

MIL-HDBK-1027/3A
31 JANUARY 1989
SUPERSEDING
MIL-HDBK-1027/3
and CH. 1
APRIL 1988

MILITARY HANDBOOK

RANGE FACILITIES AND MISCELLANEOUS TRAINING FACILITIES OTHER THAN BUILDINGS



AMSC N/A

DISTRIBUTION STATEMENT A. APPROVED FOR PUBLIC RELEASE: DISTRIBUTION IS
UNLIMITED

AREA FACR

MIL-HDBK-1027/3A

MIL-HDBK-1027/3A

ABSTRACT

This handbook presents the design criteria for training facilities other than buildings, and is intended for use by design engineers for design of new facilities and major rehabilitation of existing ranges. Range facilities are for use in training personnel in weapons firing. Weapons include small arms, aircraft, and ground weapons systems used by Navy and Marine Corps. Criteria for support facilities, parade and drill fields, and training course structures are presented.

MIL-HDBK-1027/3A

MIL-HDBK-1027/3A

FOREWORD

This handbook has been developed from an evaluation of facilities in the shore establishment, from surveys of the availability of new materials and construction methods, and from selection of the best design practices of the Naval Facilities Engineering Command (NAVFACENGCOM), other Government agencies, and the private sector. This handbook was prepared using, to the maximum extent feasible, national professional society, association, and institute standards. Deviations from this criteria, in the planning, engineering, design, and construction of Naval shore facilities, cannot be made without prior approval of NAVFACENGCOM HQ Code 04.

Design cannot remain static any more than can the functions it serves or the technologies it uses. Accordingly, recommendations for improvement are encouraged and should be furnished to Commanding Officer, Southern Division, Naval Facilities Engineering Command, Code 04A3, P.O. Box 10068, Charleston, SC 29411-0068; telephone (803) 743-0458.

THIS HANDBOOK SHALL NOT BE USED AS A REFERENCE DOCUMENT FOR PROCUREMENT OF FACILITIES CONSTRUCTION. IT IS TO BE USED IN THE PURCHASE OF FACILITIES ENGINEERING STUDIES AND DESIGN (FINAL PLANS, SPECIFICATIONS, AND COST ESTIMATES). DO NOT REFERENCE IT IN MILITARY OR FEDERAL SPECIFICATIONS OR OTHER PROCUREMENT DOCUMENTS.

MIL-HDBK-1027/3A

TRAINING FACILITY CRITERIA MANUALS

<u>CRITERIA MANUAL</u>	<u>TITLE</u>	<u>PREPARING ACTIVITY</u>
MIL-HDBK-1027/1	Fire Fighting School Facilities (proposed)	LANTDIV
MIL-HDBK-1027/2	Training Facilities, Buildings (proposed)	SOUTHDIV
MIL-HDBK-1027/3A	Range Facilities and Miscellaneous Training Facilities, Other than Buildings	SOUTHDIV

MIL-HDBK-1027/3A

TRAINING FACILITIES OTHER THAN BUILDINGS

CONTENTS

Section 1:	DESIGN CRITERIA	1
1.1	Scope	1
1.2	Cancellation.	1
Section 2:	SMALL ARMS RANGES	3
2.1	Indoor Small Arms Weapons Ranges.	3
2.1.1	Planning Factors.	3
2.1.1.1	Design Objectives.	3
2.1.1.2	Range Type and Size.	3
2.1.1.3	Local Operating Procedures.	3
2.1.1.4	Lead and Its Effect Upon Range Users.	3
2.1.2	Physical Features.	4
2.1.3	Construction Materials.	4
2.1.3.1	Sheathing and Baffles.	4
2.1.3.2	Bulletproof Materials.	5
2.1.3.3	Ceilings.	5
2.1.3.4	Floors.	5
2.1.3.5	Walls.	5
2.1.3.6	Protective Steel Plate.	6
2.1.4	Environmental Factors.	6
2.1.5	Bullet Traps.	6
2.1.5.1	Bullet Trap Steel Specifications.	8
2.1.5.2	Bullet Trap Plate Thickness.	9
2.1.5.3	Sand Pit.	9
2.1.5.4	Water Pit.	10
2.1.6	Equipment	10
2.1.6.1	Communication System.	10
2.1.6.2	Target Carrier Systems.	10
2.1.6.3	Shooting Booths.	10
2.1.6.4	Turning Targets.	10
2.1.6.5	Additional Building Facilities.	10
2.1.7	Safety Standards.	10
2.1.7.1	Firing Points.	10
2.1.7.2	Openings.	11
2.1.7.3	Protective Baffles.	11
2.1.8	Ventilation.	11
2.1.8.1	Air Flow.	11
2.1.8.2	Air Distribution.	12
2.1.8.3	Exhaust Openings.	12
2.1.8.4	Cross-Contamination.	12
2.1.8.5	Ventilation Criteria.	12
2.1.8.6	Filtration to Remove Airborne Lead.	12
2.1.8.7	Other Techniques/Controlling Airborne Lead.	12
2.1.8.8	Lead Dust in Existing Ranges.	14
2.1.9	Sound Reflection Reduction.	14
2.1.10	Lighting.	15
2.1.11	Range Design Review.	15
2.2	Outdoor Small Arms Ranges	16
2.2.1	Design Guidelines.	16

MIL-HDBK-1027/3A

2.2.2	Surface Danger Zones Over Water.	24
2.2.3	Local Operating Procedures.	26
2.2.4	Siting.	26
2.2.4.1	Location.	26
2.2.4.2	Site Characteristics.	26
2.2.5	Site Landscaping.	26
2.2.5.1	Grass Cover.	26
2.2.5.2	Poor Soil Conditions.	27
2.2.5.3	Noise Abatement.	27
2.2.5.4	Crosswinds.	27
2.2.5.5	Smaller Plants.	27
2.2.5.6	Range Walks.	27
2.2.6	Orientation.	27
2.2.7	Protective Cover.	27
2.2.8	Emplacements and Protective Berms.	27
2.2.9	Power Requirements.	28
2.2.10	Turning Targets.	28
2.2.11	Other Facilities.	28
2.2.11.1	Communication.	28
2.2.11.2	Target Repair Area.	28
2.2.11.3	Pop-up Targets.	30
2.2.11.4	Fire Protection.	30
2.2.11.5	Utilities.	30
2.2.11.6	Ready Ammunition.	30
2.2.11.7	First Aid.	30
2.2.11.8	Screening Area.	30
2.2.11.9	Additional Facilities.	30
2.3	Rifle Ranges	30
2.3.1	Parallel Ranges	30
2.3.2	Range Capacity.	30
2.3.3	Firing Lines.	30
2.3.4	Target Frames and Carriers	30
2.3.4.1	Size	30
2.3.4.2	Spacing.	30
2.3.4.3	Construction Details.	33
2.3.5	Target Butts.	33
2.3.6	Storehouse and Toilets.	33
2.3.7	Bullet Impact Berms.	33
2.3.7.1	Earthen Impact Berm.	33
2.3.7.2	Height of Bullet Impact Berms.	33
2.3.7.3	Bullet Catch.	34
2.3.7.4	Electronic Scoring Target Systems.	34
2.4	Pistol Ranges.	34
2.4.1	Surface Danger Zone.	34
2.4.2	Number of Targets.	34
2.4.3	Spacing.	34
2.4.4	Line of Sight.	34
2.4.5	Bullet Impact Berms.	34
2.4.6	Protective Canopies, Baffles and Side Berms	37
2.4.7	Other Facilities.	37
2.4.8	Close Combat Pistol Course	37
2.4.8.1	Minimum Area Required.	37
2.4.8.2	Firing Lines.	37
2.4.8.3	Target Construction.	37
2.5	Protective Baffling for Small Arm Ranges	37
2.5.1	Geometry of Baffle System.	37
2.5.2	Firing Line Canopy Shield.	37

MIL-HDBK-1027/3A

2.5.3	Overhead Baffles.	37
2.5.4	Ground Baffles.	38
2.5.5	Side Berms or Protective Side Walls.	38
2.5.6	Multiple Firing Line Baffle Ranges.	38
2.5.7	Fixed Firing Lines and Movable Target Lines.	38
2.5.8	Material Choices for Baffle Design.	38
2.5.8.1	Roof Structures.	39
2.5.8.2	Concrete Baffles.	39
2.5.8.3	Composite Overhead Baffles.	39
2.5.8.4	Wood Baffles.	39
2.5.8.5	Protection of Structural Members.	39
2.5.8.6	Grade of Lumber.	39
2.5.8.7	Material Connectors.	40
2.5.8.8	Side Berms or Protective Side Wall Construction.	40
2.5.8.9	Berm Construction.	40
2.6	Machinegun Ranges.	40
2.6.1	Surface Danger Zone.	40
2.6.2	Targets	40
2.6.2.1	Stationary Targets.	40
2.6.2.2	Moving Targets.	40
2.6.3	Salvage Wall (Impact Berm).	40
2.6.4	Storehouse and Toilet.	40
2.6.5	Other Facilities.	40
2.7	Composite Small Arms Ranges.	41
2.8	Shotgun Ranges.	41
2.8.1	Surface Danger Zone, Riot Gun Ranges.	41
2.8.2	Maximum Range.	41
2.8.3	Skeet and Trap Ranges.	41
2.9	Combat Marksmanship Course.	41
2.9.1	Targets.	41
2.9.2	Control Tower.	41
2.9.3	Power.	41
2.9.4	Target Storage.	41
2.10	Protection of Personnel.	41
Section 3.	COMMON RANGE FACILITIES	43
3.1	Siting.	43
3.1.1	Location.	43
3.1.2	Orientation.	44
3.1.3	Terrain.	44
3.1.4	Access and Range Roads.	44
3.1.5	Restricted Area Airspace.	44
3.1.6	Range Design Review.	45
3.2	Security.	45
3.3	Support Facilities.	45
3.4	Design of Support Facilities	46
3.4.1	Illumination	46
3.4.2	Utilities.	46
3.4.2.1	Electric Power.	46
3.4.2.2	Water Supply.	46
3.4.3	Structural Design.	46
3.4.4	Mechanical Requirements.	46
Section 4.	AIRCRAFT WEAPONS RANGES	47
4.1	Descriptions.	47
4.1.1	Restricted Area.	47

MIL-HDBK-1027/3A

4.1.2	Surface Impact Area.	47
4.1.3	Water Danger Area.	47
4.1.4	Air Space Requirements.	47
4.1.5	Ricochets.	47
4.2	Siting.	48
4.3	Strafing Range.	48
4.3.1	Site.	48
4.3.2	Targets.	48
4.3.2.1	Cease-Fire Point.	48
4.3.2.2	Target.	48
4.3.2.3	Run-in Line.	48
4.3.3	Control Tower.	48
4.3.4	Equipment.	49
4.4	High-Altitude Level-Bombing Range.	49
4.4.1	Site.	49
4.4.2	Targets.	49
4.4.2.1	Aiming Point.	49
4.4.2.2	Pyramids.	49
4.4.2.3	Clear Area.	49
4.4.2.4	Typical Aiming Point.	49
4.4.2.5	Trailer.	49
4.4.3	Initial Points.	49
4.4.4	Control Tower.	49
4.4.5	Spotting Towers.	50
4.4.6	Equipment.	50
4.4.6.1	Communication.	50
4.4.6.2	Range Instrumentation Equipment.	50
4.5	Multipurpose Target Range.	50
4.5.1	Site.	50
4.5.2	Targets.	50
4.5.3	Initial Points.	50
4.5.4	Flight Path Markers.	51
4.5.5	Control Tower.	51
4.5.6	Spotting Towers.	51
4.5.6.1	Air-to-Ground Range.	51
4.5.6.2	Bombing Ranges.	51
4.5.7	Rake Shacks (For Manual Scoring).	51
4.5.8	Dive Bombing Range.	51
4.5.9	Equipment.	51
4.5.9.1	Communication.	51
4.5.9.2	Plotting and Recording (For Manual Scoring).	51
4.5.9.3	Electronic Scoring.	51
4.6	Loft-Bombing Range.	51
4.6.1	Site.	52
4.6.1.1	Restricted Airspace.	52
4.6.1.2	Impact Area.	52
4.6.1.3	Single-Direction Approach.	52
4.6.1.4	Multi-Direction Approach.	52
4.6.2	Targets.	52
4.6.2.1	Aiming-Point Elevation.	52
4.6.2.2	Aiming-Point Construction.	52
4.6.3	Initial Points.	53
4.6.3.1	Spacing.	53
4.6.3.2	Details.	53
4.6.4	Distance Markers.	53
4.6.5	Control Tower.	53

MIL-HDBK-1027/3A

4.6.6	Spotting Towers.	53
4.6.7	Equipment.	53
4.7	Aerial Mining Range.	53
4.7.1	Site.	53
4.7.2	Targets.	53
4.7.3	Initial Points.	54
4.7.4	Control Tower.	54
4.7.5	Spotting Towers.	54
4.7.6	Equipment.	54
4.7.7	Small Boat Dock.	54
4.8	Close Air Support and Combat Training Area.	54
4.8.1	Site.	54
4.8.1.1	Description.	54
4.8.1.2	Surface Designation.	54
4.8.1.3	Fire Protection.	55
4.8.2	Targets.	55
4.8.3	Control Tower.	55
4.8.3.1	Water and Sanitary Systems.	55
4.8.3.2	Security.	55
4.8.3.3	Safety.	55
4.8.3.4	Visibility.	55
4.8.4	Spotting Towers.	55
4.8.5	Firehouse.	55
4.8.6	Equipment.	55
4.9	Guided Missile Range.	55
4.10	Air-to-Air Weapons Range.	55
4.11	Radar Bomb Scoring (RBS) Facility	56
4.11.1	Layout.	56
4.11.2	Function.	56
Section 5:	RANGE TOWERS	85
5.1	Function	85
5.2	Location	85
5.3	Architectural Requirements	85
5.3.1	Electronic Scoring Systems	85
5.3.2	Support Facilities	85
5.4	Mechanical Requirements.	85
5.5	Electrical Requirements.	85
Section 6:	PROJECTILE RANGES	91
6.1	Related Criteria	91
6.2	Design Factors	91
6.2.1	Target Area.	91
6.2.2	Impact Area.	91
6.2.3	Firing and Maneuvering Area.	91
6.2.4	Buffer Area.	92
6.3	Cannon Maximum Range.	92
6.4	Cannon Except Tank and Aircraft Cannon.	92
6.4.1	Definitions.	92
6.4.2	Surface Danger Zone.	94
6.4.3	Impact Area.	94
6.4.4	Maximum Range.	94
6.5	Tank Cannon.	94
6.5.1	Surface Danger Zone.	94
6.5.2	Tank Grenade Launchers.	94
6.5.3	Tank Cannon.	94

MIL-HDBK-1027/3A

6.5.4	Ammunition.	94
6.5.5	Subcaliber Tank Weapons.	94
6.5.6	Impact Area and Maximum Range.	95
6.5.7	Other Requirements.	95
6.6	Air Defense Weapons Firing at Aerial Targets.	95
6.7	Air Defense Weapons Firing at Ground Targets.	95
6.8	Mortars.	95
6.9	Rocket Launchers.	95
6.9.1	Surface Danger Zone.	95
6.9.2	Minimum Range.	95
6.10.1	Surface Danger Zone.	95
6.10.2	Firing Points.	96
6.10.3	Minimum Range.	96
6.11	Field Artillery Trainer (Air Pressure).	96
6.12	Protection of Persons Near Firing Point.	96
6.12.1	Safe Distance.	96
6.12.2	Positive Protection.	96
Section 7:	FLAME THROWERS AND GRENADE RANGES	97
7.1	Flame Throwers.	97
7.2	Grenades.	97
7.2.1	Burning Type Hand Grenade.	97
7.2.2	Fragmentation-type and Bursting-type Hand Grenades.	97
7.2.3	Rifle Grenades.	97
7.2.4	Grenade Launchers.	97
7.2.5	Tank Grenade Launchers.	97
Section 8:	LASER RANGES	99
8.1	Criteria.	99
8.1.1	Planning Factors.	99
8.1.2	Design Steps.	99
Section 9:	PARADE AND DRILL FIELDS	101
9.1	Siting and Dimensions.	101
9.1.1	Naval Training Station.	101
9.1.2	Marine Corps Recruit Depot.	101
9.1.3	Major Marine Barracks.	101
9.2	Types of Surface.	101
Section 10:	TRAINING COURSE STRUCTURES	103
10.1	Obstacle Courses.	103
10.2	Confidence Courses.	103
10.3	Combat Towns.	103
10.3.1	Size.	103
10.3.2	Locations.	103
10.3.3	Construction.	103
10.3.4	Warnings.	103
10.4	Combat Hut.	103
REFERENCES		129

MIL-HDBK-1027/3A

List of Figures

Figure 1	Indoor Range Ventilation	13
Figure 2	Surface Danger Zone for Small Arms Weapons Firing at Fixed Ground Targets	17
Figure 2a	Surface Danger Zone for Small Arms Weapons Firing at Moving Ground Targets	18
Figure 2b	Open Range With Impact Berm Surface Danger Zone for Small Arms Weapons Firing at Fixed Ground Targets	19
Figure 2c	Open Range With Impact Berm and Side Protection Surface Danger Zone for Small Arms Weapons Firing at Fixed Ground Targets	20
Figure 2d	Overhead Baffled Range with Impact Berm and Side Protection (No Ground Baffles)	21
Figure 2e	Overhead Baffled Range with Impact Berm, Side Protection, and Ground Baffles	22
Figure 3	Overhead Baffled Range With Impact Berm, Side Protection Ricochet Catcher, and Concrete Floor	23
Figure 4	Baffled Range Profile	25
Figure 5	Ballistic Protection of Target Mechanism	29
Figure 6	Parallel Ranges	31
Figure 7	Outdoor Rifle Range Layout -- Open Range	32
Figure 8	Impact Berm For Open Range and Baffled Range	35
Figure 9	Outdoor Pistol/Rifle Range Layout -- Open Range	36
Figure 10	Projectile Range Danger Zones	93
Figure 11	Typical Obstacle Course Layout	104
Figure 12	Details of Obstacles	105
Figure 13	Confidence Course Obstacles	106
Figure A-1	Rifle Range Target Carrier	108
Figure A-2	Paraleg Target Carrier	109
Figure A-3	Target Butts and Details	110
Figure A-4	Alternative Target Butts	111
Figure A-5	Eyebrow Ricochet Catcher Detail	112
Figure A-6	Overhead Baffles	113
Figure A-7	Overhead Baffle For All Pistol and Rifle Calibers up to 7.62 mm/30 Cal Ball Ammunition	114
Figure A-8	Alternative Overhead Baffles	115
Figure A-9	Firing Line Cover, Open/Impact Range	116
Figure A-10	1000-Inch Machinegun Range and Details of Rolling Target Track Support	117
Figure A-11	Open Range With Rocky Soil or Hard Targets Causing Ricochet	118
Figure A-12	Bull's Eye Lighting	119

List of Tables

Table 1	Material Specification Options for Baffles and Non-Bulletproof Surface Protection	7
Table 2	Minimum Bullet Trap Plate Thickness	9
Table 3	Maximum Allowable Exposure Limits for Intermittent Atmospheric Lead	14
Table 4	Maximum Range of Small Arms Ammunition	16

MIL-HDBK-1027/3A

Table 5	Thickness of Material for Positive Protection Against Caliber Ammunition Listed	28
Table 6	Range Types and Facility Sizing for Tower Personnel	86

List of Facility Plates

FACILITY PLATE 179-10 AIRCRAFT WEAPONS RANGES

SHEET 1	Strafing Range	57
SHEET 2	Acoustiscore Strafing Target	58
SHEET 3	Typical Aircraft Strafing Target	59
SHEET 4	Fixed Initial Point Marker	60
SHEET 5	Rocket/Bombing Range	61
SHEET 6	Multipurpose Range	62
SHEET 7	Multipurpose Target	63
SHEET 8	Alternate Multipurpose Target	64
SHEET 9	Bull's Eye Detail	65
SHEET 10	Alternate Rocket Target	66
SHEET 11	Typical Multi-target Flight Path	67
SHEET 12	Dive Bombing Range Plan	68
SHEET 13	Dive Bombing Target, Minimum Altitude Release	69
SHEET 14	Loft Bombing Range	70
SHEET 15	Loft Bombing Target, Restricted Zone, Primary Approach	71
SHEET 16	Flight Path Profile	72
SHEET 17	Flight Path Profile -- Target Area Detail	73
SHEET 18	Target Configuration for Vertically-Developed Target for High Altitude or Loft Bombing	74
SHEET 19	Distance Marker	75
SHEET 20	Aerial Mining Range	76
SHEET 21	Typical Water Target	77
SHEET 22	Typical Water Target Details	78
SHEET 23	Close Air Support and Combat Training Area Live Ordnance Multi-target Impact Area	79
SHEET 24	Typical Close Air Support Targets	80
SHEET 25	Close Air Support Target Details	81
SHEET 26	Typical Air-to-Ground Guided Missile Range-Restricted Zone	82

FACILITY PLATE 179-70 RADAR BOMB SCORING (RBS) FACILITY

SHEET 1	Radar Bomb Scoring Facility Siting	83
SHEET 2	RBS Typical Layout	84

FACILITY PLATE 179-35 AIRCRAFT WEAPONS RANGE TOWERS

SHEET 1	Control Tower	87
SHEET 2	Spotting Tower	88
SHEET 3	Utilities-Control and Spotting Towers	89

APPENDICES

APPENDIX A	WARNING SIGNS AND ADDITIONAL FIGURES	107
APPENDIX B	ADDITIONAL INFORMATION AND SUPPLIERS LIST	121
APPENDIX C	OUTDOOR SMALL ARMS RANGE CRITERIA CHECKLIST	123

MIL-HDBK-1027/3A

Section 1: DESIGN CRITERIA

1.1 Scope. This handbook provides guidance for design of small arms ranges, aircraft and gunnery ranges, range towers, parade and drill fields, training course structures, and support facilities. "Range" is used throughout the handbook to identify areas for weapons firing for personnel training (not ordnance test ranges).

1.2 Cancellation. This handbook cancels and supersedes MIL-HDBK-1027/3, Range Facilities and Miscellaneous Training Facilities Other than Buildings, and Change 1, of April 1988.

MIL-HDBK-1027/3A

MIL-HDBK-1027/3A

Section 2: SMALL ARMS RANGES

2.1 Indoor Small Arms Weapons Ranges.

2.1.1 Planning Factors. Ranges and other facilities designed and constructed using previously published criteria need not necessarily meet the requirements of this handbook. When rehabilitation is accomplished, criteria in this handbook shall be applied. When full compliance cannot be accomplished, an operational plan can often be developed that will offset the non-compliance condition. Any such operational plan will be developed by the user and submitted to the Chief of Naval Operations (CNO) for approval.

2.1.1.1 Design Objectives. Small arms are defined as handguns, riotguns (12 gauge shotguns), rifles up to 7.62 mm, and machine guns to 50 cal. Although the basic training element is the outdoor range, severe weather or safety limitations in the locale may make an outdoor range unusable. The mission of the activity may dictate that an indoor range be provided. The range design must promote safe, efficient operation and yet be affordable to construct and maintain. Where the safety of personnel is in question, the designer shall take into account the safety value of range administrative controls to mitigate the need for overly stringent design parameters and thereby keep the project within budgetary limits. When considering size and selecting materials, consider that a small arms range should be capable of providing training for all appropriate military weapons assigned to Host and Tenant commands. The indoor range could be an existing building, a new range in a separate building, or a new range as just one part of a larger new building.

2.1.1.2 Range Type and Size. Indoor ranges are designed for use of handguns firing both lead and ball ammunition up to and including .357 magnum, cal. 45 automatic and 9 mm. Rifle cartridges will normally be limited to lead cal. .22 rimfire. The use of any type of armor piercing ammunition shall be prohibited. Not every range will be designed for M-14 and M-16 firing service ammunition or shotgun. In locations where adequate outdoor facilities do not exist, the indoor facility may be upgraded to permit the use of 7.62 mm M-14, and 5.56 mm M-16 service rifles with ball ammunition. This requirement must be identified during planning. The designer must secure design criteria for structural, equipment, and safety related requirements before designing a range for automatic weapons, M-14, M-16 using service ammunition, and shotgun. Capacity of ranges will be determined in accordance with NAVFAC P-80, Facility Planning Criteria for Navy and Marine Corps Shore Installations.

2.1.1.3 Local Operating Procedures. Safety of personnel and property cannot depend upon design features alone; proper operating procedures and discipline must be established and enforced at all times. Local standard operating procedures which allow a waiver of design manual criteria shall be approved by Chief of Naval Operations (CNO).

2.1.1.4 Lead and Its Effect Upon Range Users. A clean, hazard-free, air environment is an essential design requirement for an indoor shooting range. Lead is a toxicant which will cause lead poisoning in humans exposed to excessive amounts over a period of time. The Occupational Safety and Health Administration (OSHA) has established limits of exposure to lead dust at 50 micrograms/m³/hr average for an 8-hour day (total daily exposure may not exceed 400 micrograms). For trainees and others who are exposed less than 240

MIL-HDBK-1027/3A

hours per year, this total daily dosage may be absorbed at a rate of up to 200 micrograms/m³/hr without the benefit of respiratory protection. Administrative controls should require the use of respiratory protection for full-time range personnel or limit their daily exposure to the hazard to not more than an 8-hour Time Weighted Average (TWA) of 50 micrograms/m³/hr. However, because range operation is intermittent, exposure to lead dust by shooters, instructors, and maintenance personnel is somewhat less than a full-time eight-hour day. Although design criteria could be based upon such anticipated range usage, the initial design goal for lead dust exposure is 30-40 micrograms/m³/hr TWA with an acceptable limit of 50 micrograms/m³/hr TWA. Refer to Occupational Safety and Health Administration (OSHA), Department of Labor Handbook, CFR Title 29-1910.1025c.(1) and (2) and e. (1) (ii). If subsequent testing establishes that this design limit is not achievable, an adjustment of operating hours or individual exposures as shown in Table 2 should be considered. Design criteria should be based upon anticipated range usage and local operating procedures.

2.1.2 Physical Features. Indoor ranges shall be housed in a building furnished with heating, lighting, ventilating, air conditioning (if required by criteria for comfort control in the locale) and water, sewer, and electric services. Fire protection features shall be in accordance with MIL-HDBK-1008A, Fire Protection for Facilities Engineering, Design, and Construction. Portable water dispensers, portable toilets, or use of existing facilities will be acceptable when defined as a requirement during project planning stage. Refer to DM-3.03, Heating, Ventilating, Air Conditioning, and Dehumidifying Systems, for criteria pertaining to air conditioning. The building material surfaces will be selected to facilitate housekeeping procedures for the removal of lead dust. As an example, a range floor should not be swept, but should be vacuumed with a vacuum cleaner designed for safe collection of range materials, washed down, or damp mopped. Building ledges must be minimized to reduce surfaces where lead dust will collect. The floor shall slope to floor drains located approximately 20 ft (6.1 m) downrange from the firing line for range washdown purposes. Floor drains are desirable, but not required for existing structures or for new structures not identified during planning to have piped water. Floor drains shall be designed to minimize the possibility of ricochet. Drains must connect to the treatment/filtration system or to a "sediment trap" so as not to pollute lakes or rivers.

2.1.3 Construction Materials.

2.1.3.1 Sheathing and Baffles. Wild shots that do not hit the backstop may occur on any range. It is necessary to sheath the walls, ceiling, and possibly the floor to contain wild shots. The amount of protection is dependent on the type of building construction. A suggested sheathing material is two layers of 3/4-in. (19 mm) particleboard backed with one layer of 3/8-in. (9.5 mm) plywood when the range is intended for .22 LR cal. rimfire only. Four layers of 3/4-in. particleboard backed with one layer of 3/8-in. plywood is adequate if .45 ACP hardball is the cartridge used. All non-bulletproof walls, ceilings, and possibly floors downrange must be either sheathed with bullet-containing material or baffled to divert stray bullets back into the range. Sheathing should be installed behind acoustic material.

Downrange projections such as pilasters or columns should be minimized, or protected with sheet metal baffles placed at 30 to the line of fire. Downrange electrical and mechanical installations such as lights,

MIL-HDBK-1027/3A

pipes, and ducts, shall be protected by sheet metal baffles which will divert a stray bullet back into the downrange area where its energy can be expended toward or into the backstop.

Sheet metal baffles should be constructed of sheet metal covered with plywood. Wood covering tends to reduce ricochets and backsplatter. The gauge or hardness of the metal required is dependent on the caliber to be used and the angle at which the baffles are installed. Ten or twelve gauge hot rolled sheet metal is usually sufficient if the angle of fire is 30 degrees or less. Tests have shown that 10 gauge steel set at right angles to the firing line and covered with 2 in. (50.8 mm) of soft wood will stop bullets up to .45 cal. At 30 the stopping/deflecting effect would be greater with less damage to the baffle. No metal should be placed at right angles to the line of fire without adequate wood covering.

2.1.3.2 Bulletproof Materials. Walls, floors, and roof construction must be bulletproof. Concrete masonry (gravel filled) or concrete walls, reinforced concrete floors, and flat concrete slab construction for ceilings is the preferred type of construction. Other construction materials, if used, which will not provide equivalent protection, and buildings of wood shall have protective steel plates or sandwich panels in walls, floor, and ceiling. When selecting materials, consideration will be given to the requirements for acoustic treatment, ventilation, lighting, target carrier mechanisms, and lead dust clean up.

2.1.3.3 Ceilings. Ceilings above firing line will be covered with a protective shield suitable for the most powerful cartridge authorized for range use. Shield shall extend a minimum of 12 ft (3.66 m) in front of firing line for all ranges and 3 ft (0.914 m) behind the firing line when occupied rooms are above. On existing ranges, the openings in this shield for lighting, ventilation, and target carrier mechanism shall be kept to a minimum. The remainder of the ceiling from the end of the shield to the bullet trap may be treated in the following ways:

- a) Continuous flat steel plates all the way to the trap;
- b) Ceiling baffles to protect overhead projections and joists;
- c) Continuous ceiling of sandwich construction; or
- d) Combinations of these treatments.

Final design should provide protection from stray bullets penetrating wood ceiling members and prevent ricochet from wood joists, steel bar joists, and concrete pan construction.

2.1.3.4 Floors. The preferred material is flat concrete slab or equivalent. Cover non-bulletproof floors of converted buildings with protective shield suitable for the most powerful cartridge authorized for range use. This coverage shall extend a minimum of 12 ft (3.66 m) in front of the firing line for all ranges, and 3 ft (0.914 m) behind the firing line when occupied rooms are below. The remainder of the floor from the end of this shield to the bullet trap may be covered with steel plating or suitable sandwich construction.

2.1.3.5 Walls. The preferred material is flat reinforced concrete or

MIL-HDBK-1027/3A

corefilled masonry. Cover non-bulletproof walls of converted buildings with a protective shield suitable for the most powerful cartridge authorized for range use. Shield shall extend a minimum of 12 ft forward of the firing line for all ranges and 3 ft behind the firing line when occupied rooms are adjacent. The remainder of the non-bulletproof wall extending to the bullet trap may be treated with a combination of flat steel plate, baffles, or sandwich construction. Cover the sidewalls at the bullet trap with steel plate of same thickness as the bullet trap for a distance of at least 2 ft (0.61 m) forward of the leading edge of the bullet trap.

2.1.3.6 Protective Steel Plate. Cover non-bulletproof floors and sidewalls of converted buildings with steel plate or bullet absorbing sandwich panels. Provide safety baffles set at 30 degrees to the line of fire across the range at intervals down the range ceiling to provide protection from stray bullets penetrating wood ceiling members and to prevent ricochet from wood joists, steel joists, and concrete pan construction. Thickness of steel plate or sandwich panel shall be able to withstand the most powerful cartridge to be used on the range. Commercially available baffles may be used. The angle of impact upon the plate will be the determining factor in selecting plate thickness to prevent penetration. Use of range for 5.56 mm and 7.62 mm rifle service ammunition must be determined during planning phase. Where there are rooms above, below, or beside the range, minimum plate thickness between the range and the rooms, in accordance with the angle of impact the bullet trajectory makes with the surface, shall be as shown in Table 1.

2.1.4 Environmental Factors. A range forming part of another building must provide for the following:

- a) Separated heating and ventilating systems for range (and air conditioning, if required).
- b) Effective noise reduction from pistol and rifle firing for other rooms in building and outside areas.

Locate range on outside wall of existing building. Design consideration shall be given to noise transmission and structural impact effect of bullets striking bullet traps and metal baffle plates. Consider incorporating dampening pads under supports for bullet traps if required by structural analysis. Refer to DM-3.10, Noise and Vibration Control for Mechanical Equipment; NAVFAC DM-1.03, Architectural Acoustics; and MIL-HDBK-1002/1, Structural Engineering General Requirements.

2.1.5 Bullet Traps. Ricochet and backspatter are two products of bullet projectiles that must be controlled by utilizing a properly designed and constructed bullet trap.

In existing or converted facilities, bullet traps may be steel plate set at 30 degrees to the line of fire for 5.56 mm or 7.62 mm rifle ammunition and all pistol ammunition, or 42 degrees to the line of fire for pistol only, both types with a water/sand pit. Commercially available "escalator" or "venetian blind" bullet traps will normally meet all requirements provided sufficient space is available for installation. Solid wood, stone, concrete, or brick bullet stops cause ricochets and are prohibited. The range must be designed to withstand the most powerful cartridge authorized for use on the range. New indoor ranges will normally be designed to withstand use of .357 magnum and 9 mm ammunition.

MIL-HDBK-1027/3A

Table 1

Material Specification Options for Baffles and
Non-Bulletproof Surface Protection ^(Note 1)

Caliber	Angle of Impact		
	90 degrees	42 degrees	30 degrees
	<u>Notes</u>	<u>Notes</u>	<u>Notes</u>
.22 LR Rimfire	2-12	2-12	2-12
.38 Ball or Wadcutter	3-11	3-11	3-12
.45 Ball or Wadcutter	3-11	3-11	3-12
.357 mag/9mm	4-7, 9-11	4-7, 9-11	3-7, 9-11
.44 mag	4,5,7,9-11	4,5,7,9-11	4-7, 9-11
5.56 mm Ball	4-7, 9-11	4-7,9-11	4-7,9-11
7.62 mm Ball	4,5,7	4,5,10,11	4,5,10,11
Cal.30 (30-06) Ball	4,5,7	4,5,10,11	4,5,10,11

NOTES:

1. Installed behind and in addition to desired acoustic material.
2. Two layers of 3/4-in. (19 mm) particleboard backed with one layer of 3/8-in. plywood.
3. Four layers of 3/4-in. (9.5 mm) particleboard backed with one layer of 3/8-in. plywood.
4. 12 in. (0.3 m) corefilled masonry.
5. 8 in. (203 mm) concrete slab.
6. Sandwich composed of 3/4-in. exterior grade plywood and 9 gauge, low-alloy ASTM A607 HS, Steel Sheet and Strip High-Strength Low-Alloy Columbium or Vanadium or Both Hot-Rolled and Cold-Rolled: steel, plywood, steel.
7. Sandwich composed of 3/4-in. exterior grade plywood and 9 gauge ASTM A 607 HS, low alloy steel: steel, plywood, steel, plywood, steel.
8. 10 gauge steel covered with 2 in. nominal of soft wood.
9. 1/4-in. (6.35 mm) steel plate with minimum 3/4-in. wood facing.
10. 3/8-in. steel plate with minimum 3/4-in. wood facing.
11. Steel plate appropriate for caliber from Table 1 with minimum 3/4-in. wood facing (a costly, conservative design).
12. 12 gauge steel covered with 2 in. (50.8) nominal of soft wood (while protection is adequate, Note 8 is preferred for ranges where use of .45 cal. ammunition is expected to be heavy).

MIL-HDBK-1027/3A

The ventilation system must be designed to remove all contaminants in the bullet trap area including silica dust if a sand trap is provided. Two commercially available types of bullet traps are:

a) Reverse Escalator Plate Type. The commercially available, reverse "escalator" plate type bullet trap with dry lead catcher is preferred for military ranges. The bullet trap will be selected to accommodate the most powerful weapon and ammunition to be used at the range, but no Armor Piercing (AP) ammunition. The space behind the bullet trap shall be accessible for maintenance and repair of facilities.

b) Venetian Blind Type. Where space is limited, the commercially available, "venetian blind" type bullet trap may be used. If necessary to prevent backscatter and reduce lead dust flow, provide commercially available target backing curtains of rubber or cloth, loose hung in front of the bullet trap. Types and caliber of ammunition which can be contained by backing curtains must be in accordance with recommendations of curtain manufacturer. Curtains also provide sound reduction of noises emanating from the bullet trap area.

2.1.5.1 Bullet Trap Steel Specifications. Different types of steel for use in bullet traps have been mentioned in various reports and manuals. The type of steel used in existing facilities in present backstops may be unknown. The use of "regular quality" steel plate or carbon steel plate conforming to American Society for Testing and Materials (ASTM) A36 Standard Specification for Structural Steel, is not recommended for backstops. Where this steel has been used, rapid deterioration (pitting with resultant backscatter) has been experienced even with the use of only .22 cal. rimfire ammunition. Similarly, High-Strength Low-Alloy (HSLA) steels conforming to ASTM A242/A242M Standard Specification for High-Strength Low-Alloy Structural Steel, A441/A441M Specification for High-Strength Low-Alloy Structural Magnesium Vanadium Steel, and A572/A572M Standard Specification for High-Strength Low-Alloy Columbium-Vanadium Steels of Structural Quality, do not have sufficient pitting resistance to provide an adequate backstop. Steel specifications shall conform to the following:

a) "Armor plate" steel conforming to MIL-S-16216 J(1) performs satisfactorily but is not readily available from ordinary commercial sources. Manufacturers of commercial backstops and bullet traps use an alloy steel known as ARMOR 46 (refer to MIL-A-12560 G(1) Armor Plate, Steel, Wrought, Homogeneous (For Use in Combat Vehicles and Ammunition Testing)), that has been heat-treated to a range of 340 to 440 Brinell Hardness Number (HN).

b) Abrasion-resistant carbon steel rated at 225-285/BHN is suitable for backstops where firing is limited to .22 cal. rimfire ammunition. This steel requires special welding techniques, and might not be readily available in some areas.

c) Possibly the best steel for .22 cal. rimfire ammunition (not magnums) conforms to ASTM A514/A514M Specification for High-Yield-Strength, Quenched and Tempered Alloy Steel Plate, Suitable for Welding. Surface hardness will vary from 235 BHN to 293 BHN. This steel is readily available under various trade names from major steel manufacturers and has good weldability, when low hydrogen conditions are maintained, and recommended electrodes are kept dry. The "Stringer-bead technique" is preferred with heat input limited.

MIL-HDBK-1027/3A

d) For center fire pistols the steel should be abrasion resistant conforming to BHN 320, BHN 360, and BHN 400, with such trade names as Joalloy AR-320 (Jones & Laughlin Steel Co.), X-A-R-15 (LTV), T-1 type A321 (USX), SS-AR-321 (ARMCO) and RQ-321A (Bethlehem Steel). Steels which have higher degrees of hardness are available, such as Joalloy AR-360 or Joalloy AR-400. Other steels are available and other steel companies have equivalents. Such steels are normally stocked by jobbers supplying mining, heavy engineering, and highway construction trades. Welding requirements remain the same as for ASTM A514/A514M.

The design engineer should specify the ASTM or Mil-reference number, grade of steel and other qualities, and hardness for the specific application. To ensure that the grade of steel needed is obtained, the purchaser should deal only with a reputable supplier. While steel plates look alike, there are significant differences in backstop performance depending upon the hardness and quality of alloy.

A 3/8-in. (9.5 mm) steel plate treated to 440 BHN when set at an angle of 42 degrees is sufficient for all handgun cartridges including .44 magnum. A 3/8-in. steel plate treated to 500+BHN when set at 30 degrees will accommodate cal. 30 (30-06), 7.62 mm, and 5.56 mm ball ammunition, as well as all pistol calibers.

2.1.5.2 Bullet Trap Plate Thickness. Minimum plate thicknesses shall be as given in Table 2. Plate joints shall be flush and either butt welded ground smooth or butted and bolted to a back plate on the rear with countersunk heads on the face. No joint should be horizontal or located directly behind a target.

Table 2

Minimum Bullet Trap Plate Thickness

ANGLE FROM FLOOR (degrees)	AMMUNITION (caliber)	STEELPLATE MIL-S-16216J	ARMORPLATE MIL-A-12560G	STEEL PLATE 440BHN	STEEL PLATE 550+BHN
42	.22 LR rimfire	1/4 (6 mm)	1/4	1/4	1/4
42	.38 Ball/Wadcutter	1/2 (13 mm)	3/8 (10 mm)	1/4	1/4
42	.45 ACP/Wadcutter	1/2	3/8	1/4	1/4
42	.357 mag/9 mm/.30 cal. Carbine	1/2	3/8	1/4	1/4
42	.44 mag	1/2	1/2	3/8	3/8
30	5.56 mm	NR	1/2	NR	3/8
30	7.62 mm	NR	1/2	NR	3/8
30	Cal .30 (30-06)	NR	1/2	NR	3/8

NR = not recommended.

2.1.5.3 Sand Pit. In an existing facility using an inclined plate bullet trap, a sand pit directly in front of the metal plate bullet stop may be used. The pit should be 6 to 8 in. (152.4 to 203 mm) deep and approximately 8 ft (2.44 m) wide. The pit extends the full width of the range. If silica dust cannot be eliminated by the ventilation system or by the use of wetted sand, the sand pit is prohibited.

MIL-HDBK-1027/3A

2.1.5.4 Water Pit. A water pit may be constructed using the same dimensions as a sand pit except deep enough to hold 10 to 12 in. (254 to 304.8 mm) of water for pistol calibers and a minimum of 24 in. (609.6 mm) of water for centerfire rifle calibers. Water is safer from a lead and silica-dust pollution standpoint. Consideration should be given to the addition of common laundry bleach to the water to retard algae growth.

2.1.6 Equipment.

2.1.6.1 Communication System. This system will communicate between range officer and shooters. A wireless system uses a standard two-way public address system in conjunction with headsets serving also as ear protection. Options include booth-mounted, wired, two-way speaker systems. A minimal system will be a two-way speaker system with one speaker serving every four or five firing stations.

2.1.6.2 Target Carrier Systems. Commercially available retractable target carrier systems eliminate the hazard of anyone going downrange during range operation and improve range operating efficiency. Carrier and target systems may be manual, of a type that can be converted to electric when funds become available.

2.1.6.3 Shooting Booths. Commercially available shooting booth partitions provide for safety of the shooter. Shooting booths shall not extend more than 18 in. (457.2 mm) behind the firing line to avoid restricting the view of the range officer.

2.1.6.4 Turning Targets. Automatic target turning mechanisms shall have provisions for programming any time limit for target exposure times including 3, 5, 10, 15, and 20 seconds. Manually controlled targets are acceptable for infrequently used ranges.

2.1.6.5 Additional Building Facilities. The following should be considered:

- a) Toilet facilities when piped water and drains are available.
- b) Drinking fountain.
- c) Bulletin board.
- d) Range control room or platform, control consoles, chairs, and benches.
- e) Emergency eyewash, if weapons cleaning capability is included.
- f) Storage closet for equipment.

2.1.7 Safety Standards. A safe range is defined to be a facility that will contain all bullets within its walls, ceiling, and floor when operated by a qualified range officer who follows a standard operating procedure specifically tailored for the range. Safety standards described in paras. 2.1.7.1 through 2.1.7.3 shall be observed.

2.1.7.1 through 2.1.7.3 shall be observed.

2.1.7.1 Firing Points. Space firing points for pistol ranges and rifle or rifle-pistol ranges as follows.

MIL-HDBK-1027/3A

a) Pistol Ranges. On ranges used exclusively for pistol firing, firing points shall be placed a minimum of 4 ft (1.22 m) (preferably 4.5 ft (1.5 m)), on center.

b) Rifle or Rifle-Pistol Ranges. On ranges used exclusively for rifle, or rifle and pistol firing, firing points shall be placed a minimum of 4 ft (1.22 m), preferably 5 ft (1/52 m) on center.

2.1.7.2 Openings. No door, window, or other opening, except any required for forced air ventilation, is allowed forward of the firing line. Where an existing building is converted, all such openings must be brick or masonry filled, and doors and windows securely bolted from the inside or protected by steel safety baffles. In new buildings, conceal all pipes and conduits in the walls, ceiling, and floors. Protect exposed pipes in converted buildings with steel plates to match design requirements for the most powerful cartridge to be used. Commercially available safety baffles may be used. In some situations fire doors may be required downrange. When fire doors are required, they may be opened only from the range side.

2.1.7.3 Protective Baffles. Downrange projections shall be minimized in new construction. All beams, columns, lights, or other projecting surfaces downrange of the firing line shall be protected. This protection can be a steel plate to match the most powerful cartridge used or a commercially available safety baffle providing comparable protection. Sheet metal baffles placed at 30 degrees to the line of fire to protect lighting fixtures may be constructed to thickness shown in Table 1 or may be commercially available safety baffles. Design of baffle should not create a problem with vision lighting.

2.1.8 Ventilation. The supply and exhaust air system design is critical to the proper operation of an indoor range. Provide a positive exhaust ventilation system for removal of airborne lead dust (and silica dust in the case of an existing range using sand traps). A slight negative air pressure should be maintained in the range. This can be accomplished by exhausting three to seven percent more air than is supplied. Air inlets must have dampers or other volume control devices which can be adjusted to retain proper air balance. Consideration should be given to energy recovery systems because of the large volumes of air being exhausted.

2.1.8.1 Air Flow. Air flow of 75 ft per/min or 1.25 ft/sec (22.86 m/min or 0.38 m/sec) across the firing line is recommended, and a minimum acceptable air flow is 50 ft/min (15.2 m/min). At a point approximately halfway between the firing line and the bullet trap, the air flow should be maintained at 20 to 30 ft/min (6.1 to 9.14 m/min). The flow should be evenly distributed past the shooter. It is important to have the required velocity without it being excessive at any shooting position. The design engineer should avoid excessive entrance air velocity and keep the sonic exposure from the ventilation system below 85 dBA. For initial design, the minimum quantity of total ventilation for a range shall be the greater of the cross sectional area at the firing line times the maximum design velocity, 75 ft/min, or the average range cross-sectional area (downrange of the firing line) times the maximum downrange velocity of 30 ft/min. In calculating the cross sectional area at the firing line, it should be assumed that shooting booth doors are open.

MIL-HDBK-1027/3A

2.1.8.2 Air Distribution. A perforated rear wall will provide uniform air distribution to ensure diffuse, nonturbulent airflow toward the firing line and laminar airflow downrange to sweep contaminants away from the firing line. A minimum distance of 15 ft (4.57 m) from the firing line to the perforated rear wall should be provided. Ceiling supply systems are permitted in existing facilities provided the minimum flow of 50 ft/min (15.2 m/min.) at the firing line is maintained; however, a back wall supply is preferred. A minimum of 20 ft/min (6.1 m/min.) must be maintained downrange for satisfactory visibility. To maintain the downrange velocity economically where construction permits, an 8-ft high (2.44 m) cross section (under any protective baffles) is recommended. See Figure 1 for indoor range ventilation. If separate supply air and exhaust air fans are used, they shall be interlocked to prevent independent operation.

2.1.8.3 Exhaust Openings. An optional set of exhaust openings may be located approximately 15 ft (4.57 m) forward of the firing line (not over the firing line) to exhaust not more than 25 percent of the total airflow. The remainder of the exhaust openings will generally be located at the apex of the bullet trap area. Modification of existing ranges to this design is not required so long as a flow of 50 ft/min is maintained at the firing line.

2.1.8.4 Cross-Contamination. The exhaust discharge from the range must be separated from the supply air intake to prevent cross-contamination of lead fumes unless the exhaust air is filtered prior to discharge. If range is a part of a larger building, exhaust air discharge will not be located where cross contamination of general building air can occur. Intake air should be located to avoid recirculation of exhaust air.

2.1.8.5 Ventilation Criteria. For design of the ventilation system, refer to DM-3.03 and American Conference of Governmental Industrial Hygienists, Industrial Ventilation Manual. Refer to DM-3.03 for criteria for inside comfort conditions.

2.1.8.6 Filtration to Remove Airborne Lead. Filtration of exhaust air to the outside will be designed in accordance with current OSHA and local regulatory requirements. Recirculation of range air is permitted only if it is properly filtered for airborne range contaminants and includes dirty filter indication. If required by Government or local regulations, High Efficiency Particulate Air (HEPA) Filter shall be provided. Provisions should be made in the design for increasing fan horsepower and static pressure in the future for HEPA installation if not an initial design requirement.

2.1.8.7 Other Techniques/Controlling Airborne Lead. There are techniques for controlling airborne lead such as building a wall in front of the firing line and shooting through 18 in. diameter (457 mm) ports, thus separating the muzzle from the face of the shooter. Another technique is shooting through a cylinder which has an exhaust connection to remove airborne lead as it leaves the muzzle. Electronic lead dust collection plates will be considered for heavily used ranges where the savings generated by less frequent changes of the expensive HEPA filters will offset the cost and the equipment costs. Unique and unusual installations are outside the scope of this manual. Approval from the using activity must be obtained before using these techniques. Criteria may be obtained from the National Rifle Association or other expert authority.

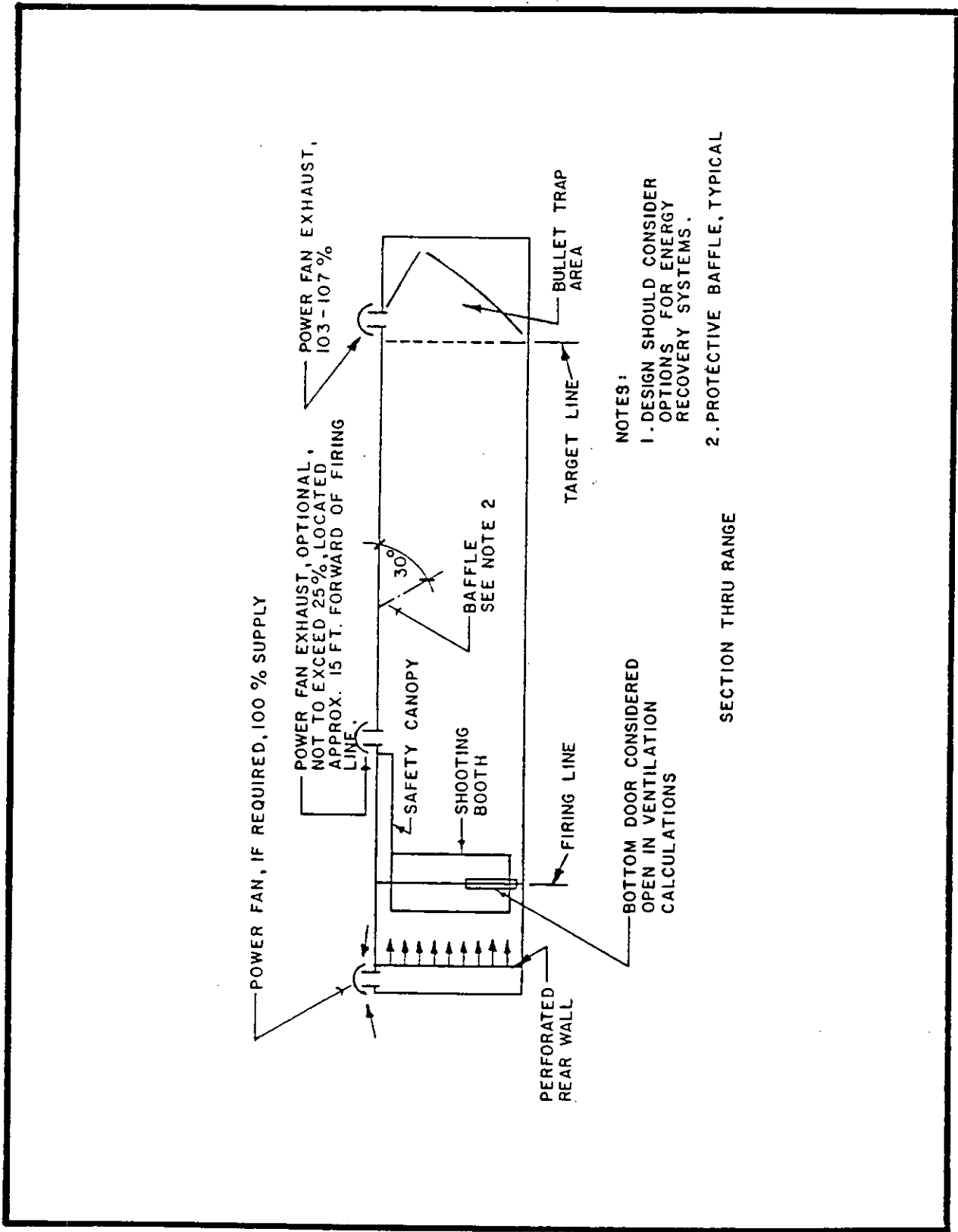

Figure 1

Indoor Range Ventilation

MIL-HDBK-1027/3A

2.1.8.8 Lead Dust in Existing Ranges. The use of special training ammunition may be considered to reduce the cost of rehabilitation of an existing ventilation system; only if command assurance is provided that all users of the range will use this type ammunition. An existing indoor range with a lead dust level in excess of normal exposure limits may be operated following the restricted criteria found in Table 3. Table 3 is developed and used by the US Army and the National Guard. Any constraints on range use must be in writing and included in the Standard Operating Procedure for the range.

Table 3

Maximum Allowable Exposure Limits for Intermittent Atmospheric Lead

AIRBORNE LEAD CONCENTRATION (micrograms/m ³)	MAXIMUM HOURS OF ALLOWABLE EXPOSURE			
	FIRING 30 OR MORE DAYS/YEAR		FIRING LESS THAN 30 DAYS/YEAR	
	Hrs/Week	Hrs/Day	Hrs/Week	Hrs/Day
0 - 0.03	40	8	40	8
0.03 - 0.05	24	8	32	8
0.05 - 0.10	12	6	18	6
0.10 - 0.15	8	4	12	4
0.15 - 0.20	6	3	9	3
0.20 - 0.25	4 1/2	2 1/2	7 1/2	2 1/2
0.25 - 0.30	4	2	6	2
0.3 - 0.4	3	1 1/2	4 1/2	1 1/2
0.4 - 0.5	2 1/2	1	3	1
0.5 - 0.7	1 1/2	1/2	1 1/2	1/2
0.7 - 1.0	1	1/2	1	1/2
1.0 - 2.0	1/4	1/4	1/2	1/4
2.0 - 4.0	1/4	1/4	1/4	1/4
4.00	0	0	0	0

2.1.9 Sound Reflection Reduction. Noise reduction in the range and noise transmission out of the range are two different design considerations. Mass and limpness are the two desirable attributes for a sound transmission barrier. Heavy masonry walls are generally the most economical method for isolating the range. Other types of construction such as gravel or grout

MIL-HDBK-1027/3A

filled concrete block will provide mass. Absorptive acoustical surfacing will reduce the noise level in the range but will have little effect on transmission outside the range. Blown-on acoustical material is not permitted. Conventional acoustical treatment is encouraged behind the firing line. Downrange acoustic treatment must be compatible with the planned lead dust removal process. Do not paint downrange block walls or acoustic tile sound absorbing walls; this significantly degrades the sound absorbing qualities of the materials. Existing ranges may continue use of painted surface.

Wall treatment should be installed in not larger than four foot wide panels to facilitate replacement after damage. Install acoustic wall treatment on furring strips spaced away from the wall. Ventilation duct openings should have noise traps to reduce noise transmission to outside or other occupied building areas. The floor area behind the firing line may be covered with acoustic material that can withstand the chosen lead removal process. While carpet is not recommended, it need not be removed from existing facilities. Airborne noise can be reduced by sealing off air leaks. Doors should be solid core, weather stripped. Provide double doors (air lock arrangement) when connecting directly with another part of a larger building. Double glazing of windows into control rooms will reduce transmission.

2.1.10 Lighting. Provide general downrange lighting for safety and cleanup purposes as well as for general range illumination. The preferred method is a continuous bank of fluorescent lights with supplemental halogen or a combination of lights running the full width of the range. Light intensity at target face should be between 85 to 100 footcandles measured 4 feet (1.22 m) above the floor at the target. The ideal light wavelength is 550 plus or minus 50 nanometers. Range should have dimmer on lighting to satisfy various training requirements of using activities.

2.1.11 Range Design Review. For weapons to be fired, weapons type, ammunition to be fired, and distances of firing line to targets must be determined during the planning phase. Other design considerations include: number of firing points; lighting possibilities; manual and automatic target carrier/turning mechanisms; offices or at least tables for administrative support; shooting benches; clocks and timers; ventilation; ease of lead dust cleanup; spectator safety; acoustics; lead dust control; lead removal from lead dust collectors and bullet traps. A range which adjoins a classroom requires soundproofing. Glass walls separating firing points from waiting areas may be used to reduce noise and lead dangers to spectators or waiting shooters.

During the planning phase, the weapons officer, range officer, range training officer, safety officer, industrial hygienist, and public works engineer should review the design requirement before construction drawings are started. When the station or design agent is unable to proceed with preparation of construction drawings in accordance with the criteria of this design manual, requests for deviation must be addressed to Commander, Naval Facilities Engineering Command, Code 04, 200 Stovall Street, Alexandria, VA 22332-2300. During the design phase, submittal reviews by the appropriate Naval Industrial Hygienist are required in accordance with NAVFACINST 6260.2, Reviews For Health Hazards During Facility Design Process, and may be required by the appropriate Engineering Field Division (EFD) in accordance with EFD-published instructions.

MIL-HDBK-1027/3A

2.2 Outdoor Small Arms Ranges

2.2.1 Design Guidelines. Small arms range design must prevent injury to personnel or property damage outside the range from misdirected or accidental firing and ricochets; and be so designed as to direct ricochets away from the firing line inside the range. If there is enough distance and land area available, an open range may be sited allowing for surface danger zone appropriate for the weapons intended to be used. See Figures 2 through 2e and Figure 3 for surface danger zones for firing of small arms weapons. These figures are for firing at fixed ground targets, except Figure 2a which shows open range impact area requirements for firing at moving targets. These figures show projectile impact and ricochet areas for soft, dry, loamy soil. Ranges having soil containing rocks or requirements for firing on hard targets will require larger areas. Criteria for such conditions will be obtained during the planning phase for new ranges. Figure A-11 of Appendix A shows surface danger zone requirements for such range conditions. Table 4 shows the maximum range for ammunition listed and should be used in conjunction with Figures 2 through 2e and Figure A-11 of Appendix A.

Table 4

Maximum Range of Small Arms Ammunition

Caliber	Maximum Range (in meters) for Most Powerful Cartridge
.22 long rifle	400
.38 revolver	Ball, M41 1600
	Ball, PGU-12/8 1900
.45 pistol	1500
.45 submachinegun	1600
.357 magnum	2160
9 mm pistol	1740
9 mm submachinegun	1840
.44 magnum	290
.50 machinegun	Ball, M33 6500
	AP, M26 100
shotgun, 12 GA. riot (00 buckshot)	600
.30 rifle and machinegun	
	Ball, M23 100
	AP, M2 4400
.30 carbine	300
5.56 mm rifle	Ball, M193 100
7.62 mm rifle and machinegun,	
	Ball M80 4100
	Match, M118 4800

MIL-HDBK-1027/3A

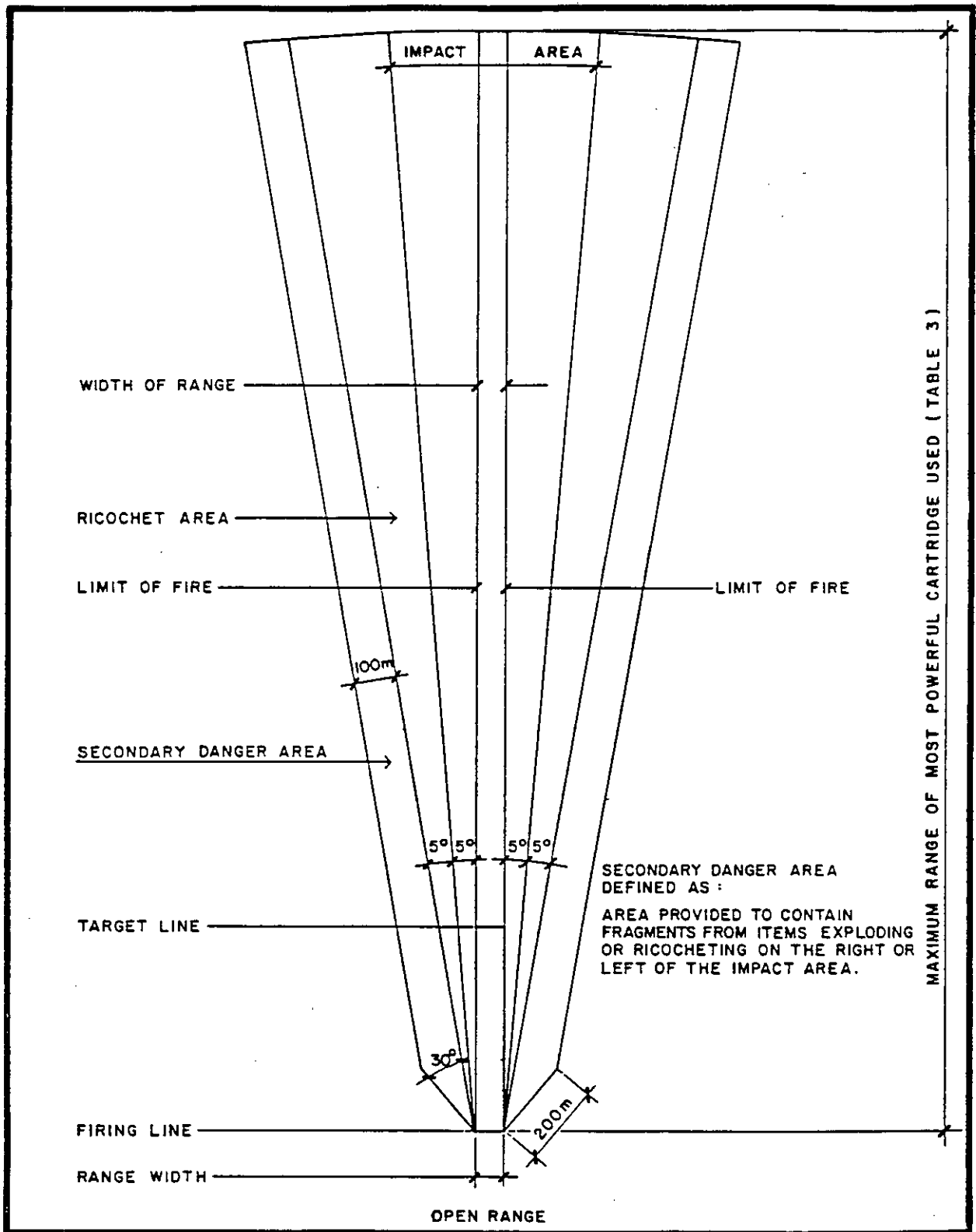

Figure 2

Surface Danger Zone for Small Arms Weapons
Firing at Fixed Ground Targets

MIL-HDBK-1027/3A

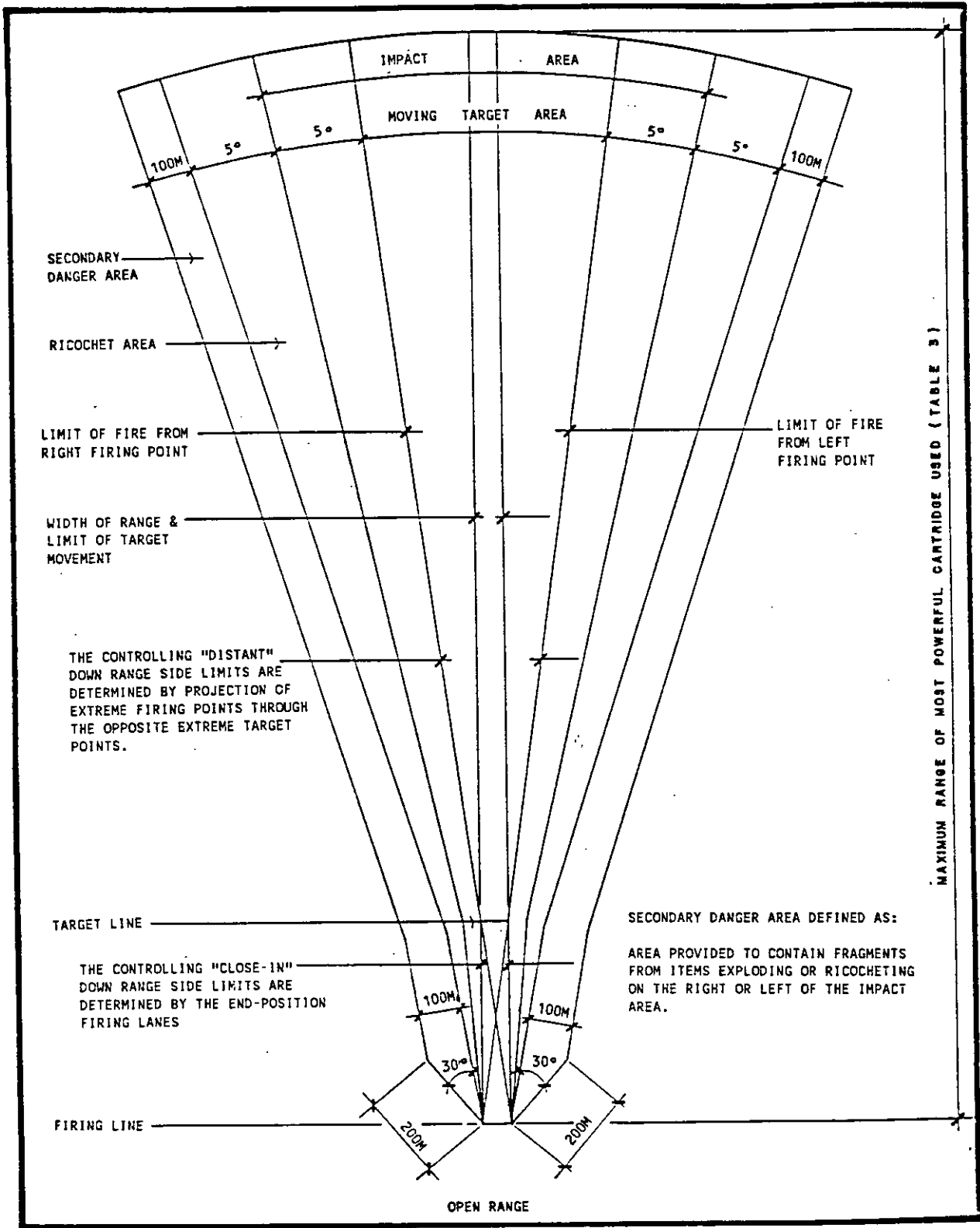

Figure 2a

Surface Danger Zone for Small Arms Weapons
Firing at Moving Ground Targets

MIL-HDBK-1027/3A

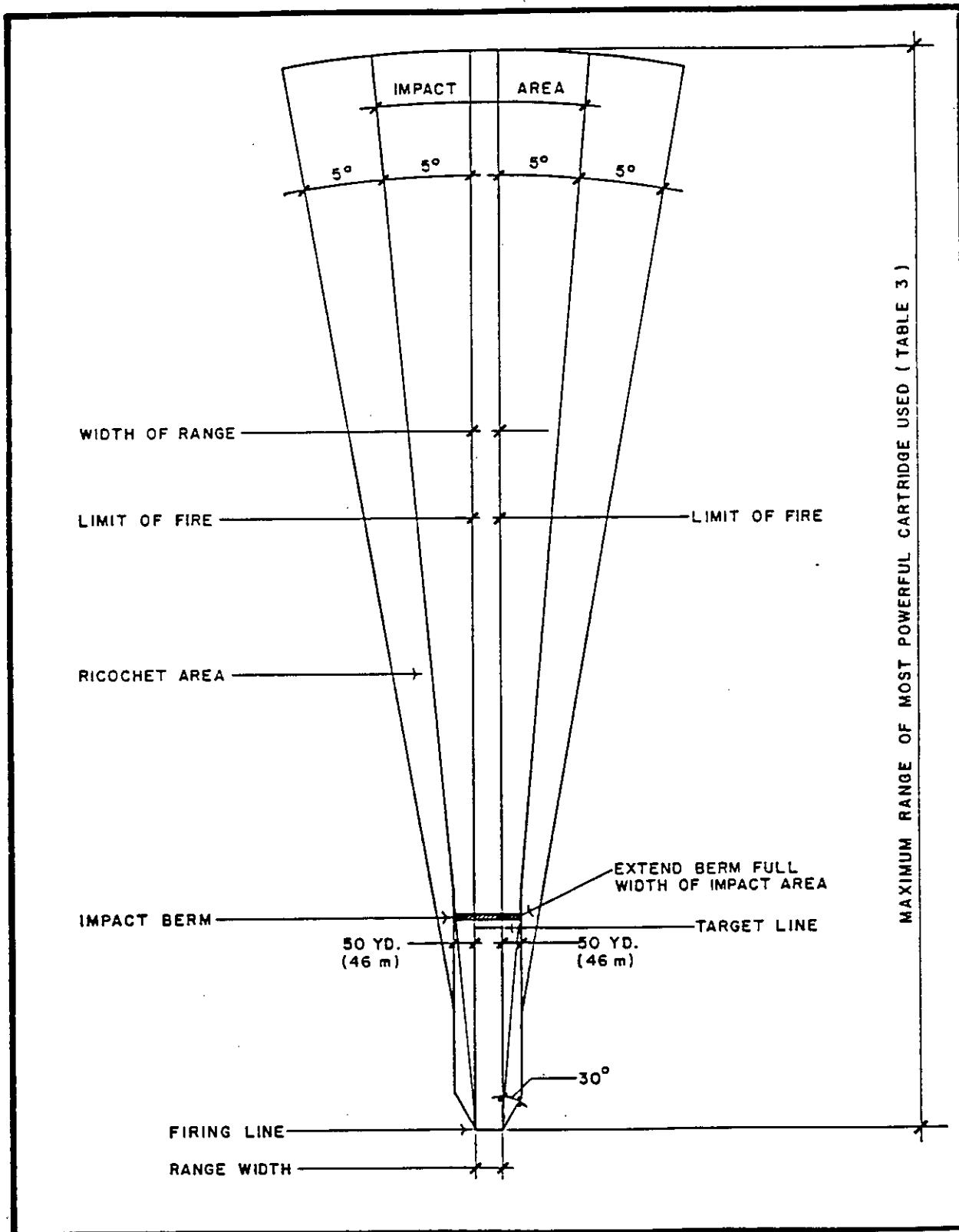

Figure 2b

Open Range With Impact Berm Surface Danger Zone
for Small Arms Weapons Firing at Fixed Ground Targets

MIL-HDBK-1027/3A

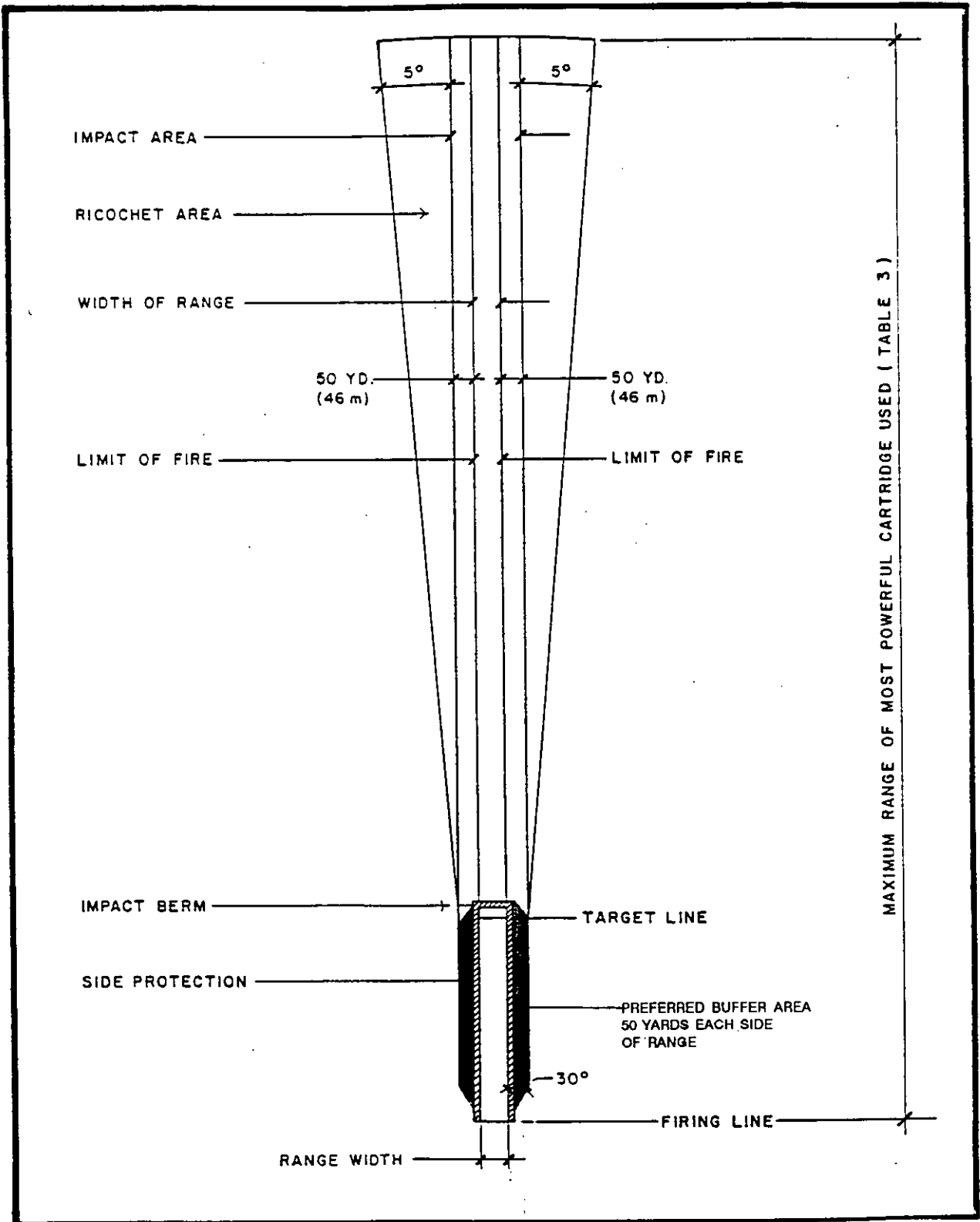

Figure 2c

Open Range With Impact Berm and Side Protection Surface Danger Zone for Small Arms Weapons Firing at Fixed Ground Targets

MIL-HDBK-1027/3A

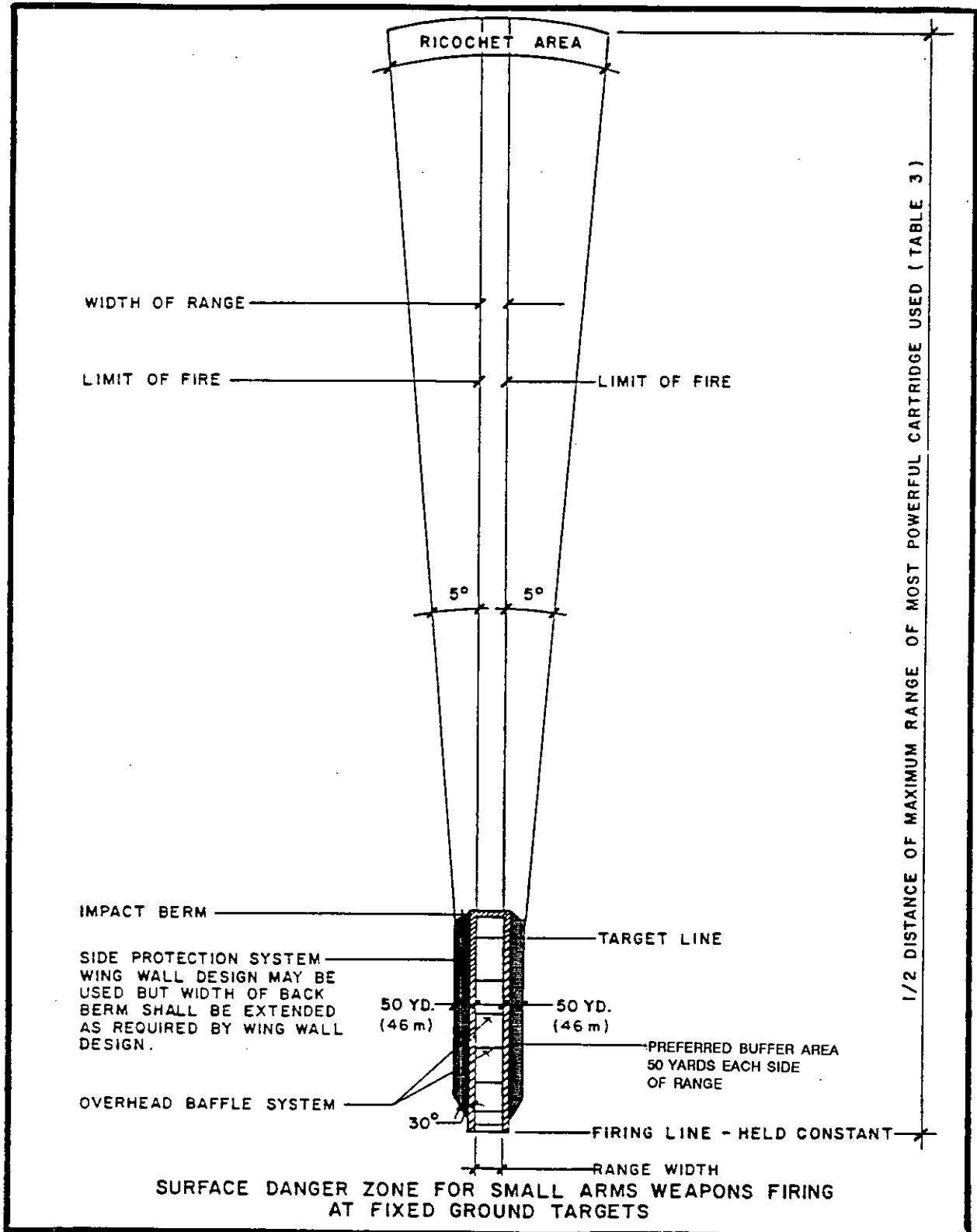

Figure 2d

Overhead Baffled Range with Impact Berm and Side Protection (No Ground Baffles)

MIL-HDBK-1027/3A

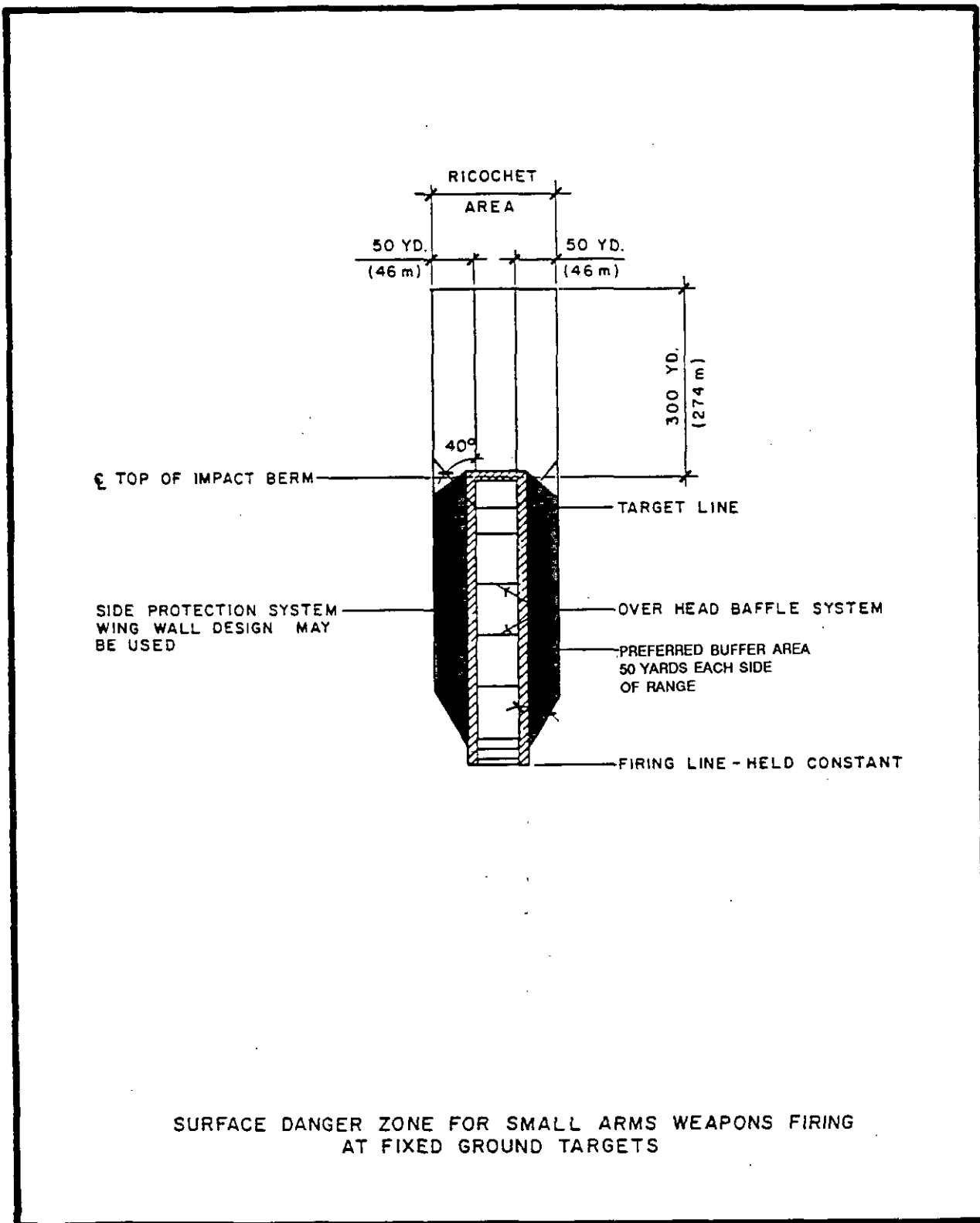
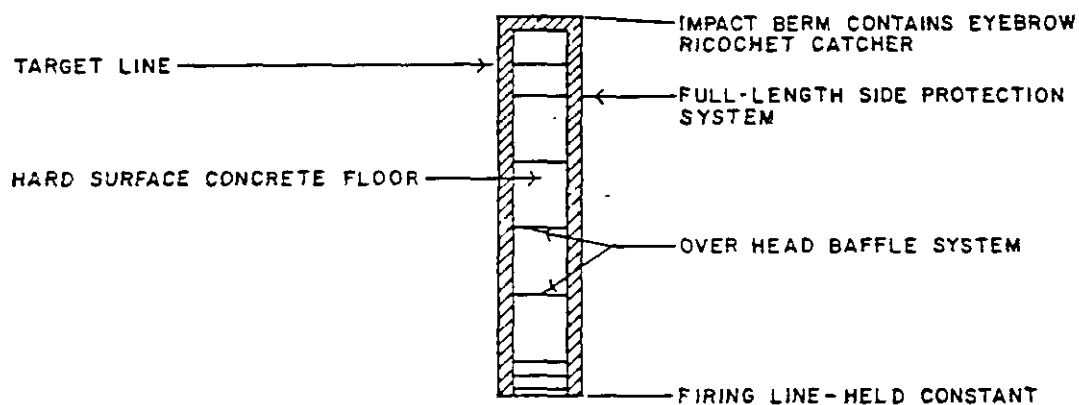

Figure 2e

Overhead Baffled Range with Impact Berm,
Side Protection, and Ground Baffles

MIL-HDBK-1027/3A



NO SURFACE DANGER ZONE REQUIRED FOR SMALL ARMS WEAPONS FIRING
AT FIXED GROUND TARGETS

Figure 3

Overhead Baffled Range With Impact Berm, Side Protection
Ricochet Catcher, and Concrete Floor

MIL-HDBK-1027/3A

The range must be baffled when there is insufficient distance to lay out a new range with the surface danger zones shown for the open range, or where encroachment into the surface danger zone has occurred on an existing range, as well as for noise or environmental related reasons. Figures 2b through 2e and Figure 3 illustrate the tradeoffs involved in going from the open range (Figure 2) to a fully bermed and baffled range (Figure 3). A fully baffled system consists of overhead baffles and ground baffles, a canopy shield over firing points, bullet impact berm, side berms, and sidewalls or side baffles. A fully baffled range is constructed so that all direct fire can be contained in the range proper. Refer to Figure 4 for Baffled Range Profile.

A ricochet area is provided for containment of any ricochets that may escape from such items as the range floor, target frames, etc., (see Figures 2d and 2e). The minimum ricochet containment area is that shown in Figure 2e. Wherever site conditions will permit, it is desirable to provide at least this minimum 300 yd (274 m) containment area. Where site conditions are insufficient to provide even this minimum area, its need can be eliminated on a properly designed fully baffled and side-protected range having an eyebrow ricochet catcher on the impact berm and a range floor paved with hard surface concrete, as illustrated in Figure 3. Impact on concrete range floor at 27 degrees or less to line of fire will deflect ricochets downrange in a predictable path, thereby eliminating need for ground baffles. The impact berm is an important element once the firing line and the most distant target line is located. The impact berm is designed to contain bullets fired at and around the targets. On a baffled range complete control of the users is necessary to reduce facility damage, maintenance, and repair costs. Figures 2 and 2a have no impact berm, side or overhead protection, and contain areas designated as impact areas, ricochet areas, and secondary danger areas. The ricochet area is an angle of deflection of 5 degrees beyond both sides of the impact area. The entire surface danger zone must be either Navy owned or legally authorized for Navy use and must be under complete control during range operations.

2.2.2 Surface Danger Zones Over Water. In some cases it is economical to orient a rifle range (or a pistol range) so that some or all of the surface danger zones fall upon navigable waters which are not under absolute control of the Range Safety Officer. This alternative could reduce or eliminate the requirement for side berms and baffling. Prior approval of such a plan must be obtained from CNO and COMNAVFACENGCOM. If this method is chosen, the following range control methods may be required prior to obtaining CNO authorization to use the range.

The limits of the water impact area must be shown on local navigation charts as a surface danger zone. A notice to mariners must be published routinely to warn all marine interests to stand clear when the range is in operation. At each end of the target line, a pole shall be erected to display the largest red range flag practicable (size similar to "Holiday Colors") and with either a flashing red beacon or white strobe light. Buoys marking the outer limits of the danger zone may be required. An observation tower may be erected just behind the most distant firing line. Height should be sufficient to allow full view of the danger zone. A lookout having direct communication with the firing line is posted to assure that all firing is stopped until the surface danger zone has been cleared.

MIL-HDBK-1027/3A

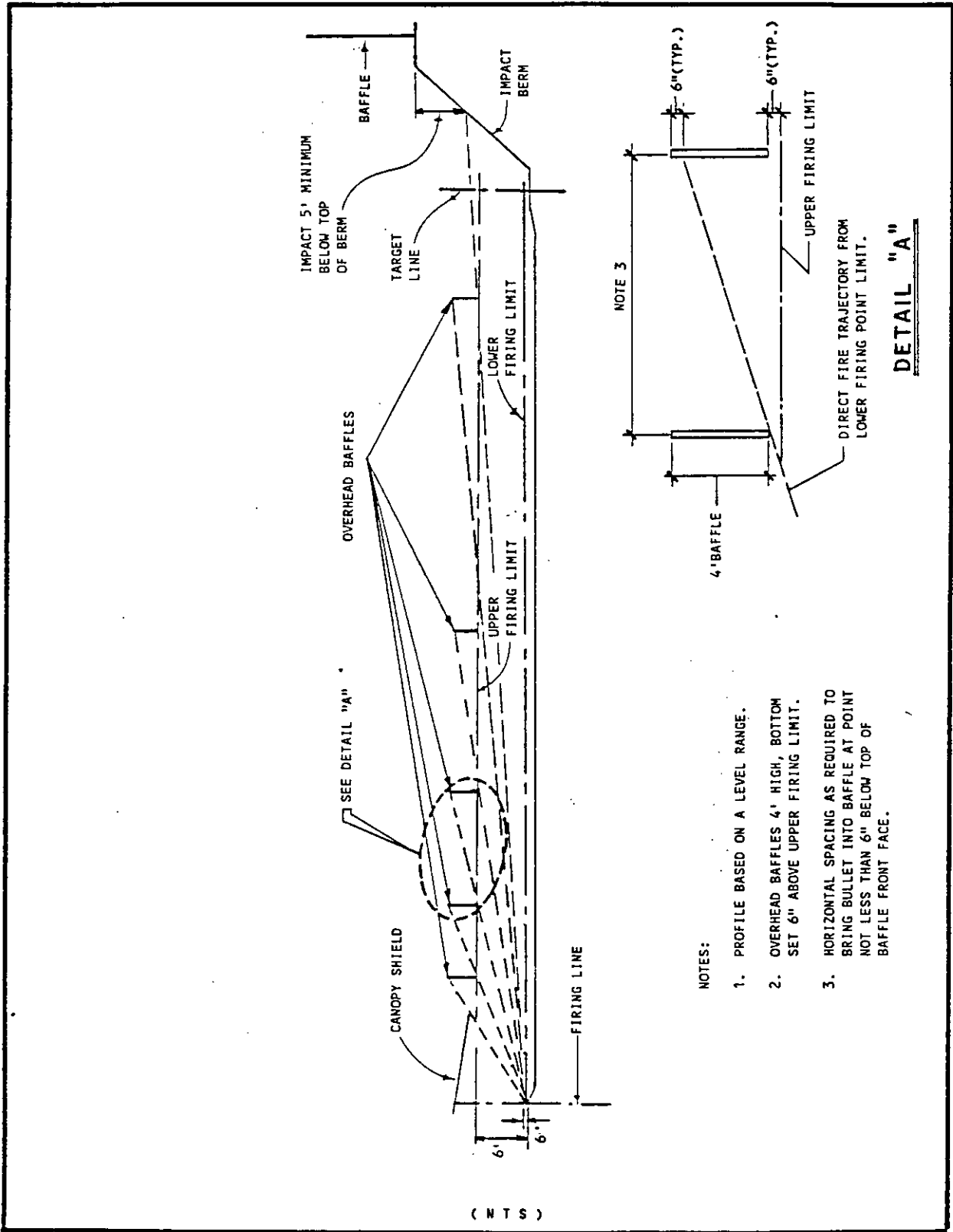

NOTES:

1. PROFILE BASED ON A LEVEL RANGE.
2. OVERHEAD BAFFLES 4' HIGH, BOTTOM SET 6" ABOVE UPPER FIRING LIMIT.
3. HORIZONTAL SPACING AS REQUIRED TO BRING BULLET INTO BAFFLE AT POINT NOT LESS THAN 6" BELOW TOP OF BAFFLE FRONT FACE.

Figure 4

Baffled Range Profile

MIL-HDBK-1027/3A

2.2.3 Local Operating Procedures. Safety of personnel and property on-range and off-range must be controlled by proper range operation and discipline at the range. Controlling the direction in which a barrel is pointed can aid in keeping bullets within the range. Warning signs must be placed on approach to the range. Red flags or rotating/flashing red lights will be posted to indicate when range is in use. Rifle ranges will have provisions for flags at each end of the impact berm/target line and each firing line to indicate wind direction for the shooters.

2.2.4 Siting. Criteria for the selection of sites for small-arms ranges are described in paras 2.2.4.1 and 2.2.4.2.

2.2.4.1 Location. Sites should be remote from communities to reduce complaints from neighboring occupancies, and be accessible by road. Surface danger zones should not extend across traveled roads, navigable waterways, railroads, airports, or recreational areas. Surface danger zone shall be U.S. Government controlled. Surface danger zone shall be laid out and recorded on station maps to prevent future encroachment.

If other methods to control access to surface danger zones are not effective, fencing shall be provided to exclude people and animals. Natural barriers around the site; i.e., rivers, hills, or large drainage channels, will help prevent encroachment and will assure privacy; however, consider that people use rivers and hills. Ideally, the best site would be one having a natural backstop for projectiles to cut down on the cost of constructing earth impact berms and to provide natural sound abatement.

Existing stations are usually limited in area and these ideal situations will be hard to obtain. A combination of natural and constructed barriers may be possible.

2.2.4.2 Site Characteristics. Sites shall have natural drainage, require little grading, and be free from ledge rock and boulders. The range floor shall be clear of trees, but trees are allowed in surface danger zone downrange of impact berm and outside side berm, side walls, or side baffles. The ground shall rise to the rear of the targets. The following criteria shall apply:

a) The range site should be almost flat with a slight grade from side to side between 1 percent and 2 percent to allow for storm water runoff.

b) On baffled ranges the side to side grade must not exceed 2 percent because of the geometry of the baffled system. This is not a requirement for open/impact ranges.

c) The firing line and the target line ideally should be at the same elevation with the grade between the two points low enough so that vegetation does not obscure targets.

2.2.5 Site Landscaping. The site should be landscaped for erosion control, noise abatement, maintenance, accuracy, appearance, fire protection and safety.

2.2.5.1 Grass Cover. Berms should be planted with grass to prevent erosion. Ground cover is acceptable on existing berms which have been maintained and erosion is not a problem. Grass must be type selected for geographic area

MIL-HDBK-1027/3A

which will readily grow and provide good coverage. Degree of shading caused by overhead baffles will determine type of grass for range floor. Excessive shading in front of firing line may dictate use of a synthetic turf. Refer to NAVFAC MO-100.1, Natural Resources Land Management, for types of grasses and ground cover. Select grasses and cover for earth berms that are not accessible by moving equipment so that natural growth heights will be acceptable.

2.2.5.2 Poor Soil Conditions. In areas where the soil is poor or extremely sandy, plants such as Bermuda grass (devil's grass), ice plant, or vine root can be used to control soil erosion.

2.2.5.3 Noise Abatement. Heavy landscaping may be used to cut down on noise transmission. Plants and trees may be planted behind firing position shelters to alleviate noise transmission problems. Soundproofing of firing line structures should be considered in problem areas. Trees should be kept away from firing lines to allow Range Control Officers to see all shooters.

2.2.5.4 Crosswinds. Trees for windbreaks may be planted along the length of the range with partial side berms or wing walls where strong prevailing crosswinds are problems to shooting accuracy.

2.2.5.5 Smaller Plants. Densely planted rows of fast growing compact and thorny shrubs may be planted below the trees at ranges with partial berms or wing walls to abate noise, prevent encroachment, and alleviate crosswind problems.

2.2.5.6 Range Walks. Turfed walkways shall have a base consisting of sand, cinders, or top soil; these materials permit fewer ricochets. Concrete walkways slightly below grade are recommended to reduce maintenance. Concrete walkways will not increase the ricochet hazard for bullets striking at angles of 27 degrees or less.

2.2.6 Orientation. If at all possible, ranges shall be oriented to eliminate all firing into the sun. Other safety considerations being equal, face the range to the north or slightly to the northeast in the Northern Hemisphere remembering that the best orientation is the safest direction. The ideal direction is between due north and 25 degrees east of north. Other directions will be allowed if proper safety features are provided as might be provided for in a baffled range. On a fully-baffled pistol range, sun angle is not usually a problem; however, sun angle can be a problem on baffled rifle ranges where target backlighting would cause the shooter to have difficulty in discerning the precise point of aim to hit the bull's eye.

2.2.7 Protective Cover. Table 5 shows the thickness of various materials needed to provide positive protection against individual bullet impact. The material will not provide protection against continued burst firing.

2.2.8 Emplacements and Protective Berms. The mechanisms, devices, controls, and wiring for electronic targetry such as for turning and pop-up targets will be protected from damage by direct hits, ricochet, and flying debris. (See Figure 5 for emplacement protection.) In a permanent installation, an earth protected emplacement is preferable to wood log protection. Wood gets shot up and must be replaced regularly. The target emplacement design must be matched to the design of planned equipment and auxiliaries which are to be installed. Protective shields will be needed for

MIL-HDBK-1027/3A

Table 5

Thickness of Material for Positive Protection
Against Caliber Ammunition Listed

COVER MATERIAL	THICKNESS IN INCHES		
	5.56 mm	7.62 mm & Cal .30	Cal .50
Concrete (5000 psi)....	5" (127mm)	7" (177.8mm)	12" (305mm)
Gravel-filled concrete			
masonry units	8" (203mm)	12" (305mm)	24" (610mm)
Broken Stone	14" (356mm)	20" (508mm)	30" (762mm)
Dry sand	16" (406mm)	24" (610mm)	32" (813mm)
Wet sand	25" (635mm)	36" (914mm)	48" (1.22m)
Oak logs			
(wired together)	28" (711mm)	40" (1.02m)	56" (1.42m)
Earth			
Packed or tamped	32" (813mm)	48" (1.22m)	60" (1.52m)
Undisturbed compact..	35" (889mm)	52" (1.32m)	66" (1.68m)
Freshly turned	38" (965mm)	56" (1.42m)	72" (1.83m)
Plastic clay	44" (1.12m)	65" (1.65m)	100" (2.54m)

See Table 2 for steel plate and other small arms.

items such as lights, hit sensors, and return fire simulators. The design must facilitate the removal, replacement, or repair of equipment and auxiliaries. For access by maintenance vehicles, consideration should be given to placement and size of entry gates. For access by maintenance machinery, consideration should be given to placement and size of doors and windows.

2.2.9 Power Requirements. Console operated electronic target mechanisms and control systems will be electrical hardwire power, usually 120/240 V, 1 phase, 60 Hz.

2.2.10 Turning Targets. If installed, automatic target turning mechanisms shall have provisions for the following target exposure times: 3 seconds, 5 seconds, 10 seconds, 15 seconds, and 20 seconds. Manually controlled targets are acceptable for infrequently used ranges.

2.2.11 Other Facilities. Paras. 2.2.11.1 through 2.2.11.9 define design guidance for other facilities.

2.2.11.1 Communication. Provide for communication between target pits (if manual target carriers are used) and firing lines; i.e., battery-powered field phones, buried telephone lines, sound powered phones, or radios with discrete frequencies. Provide public address system with sufficient number of speakers to verbally control range.

2.2.11.2 Target Repair Area. Locate target repair areas so that targets may be repaired while the range is operating. Provide space for storage of rotary or pop-up target panels.

MIL-HDBK-1027/3A

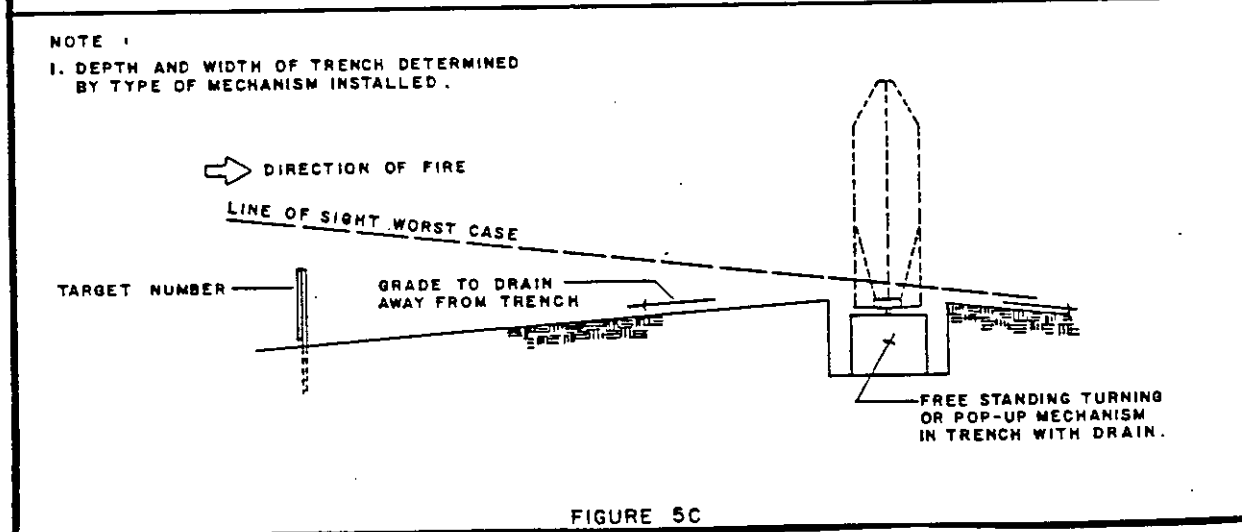
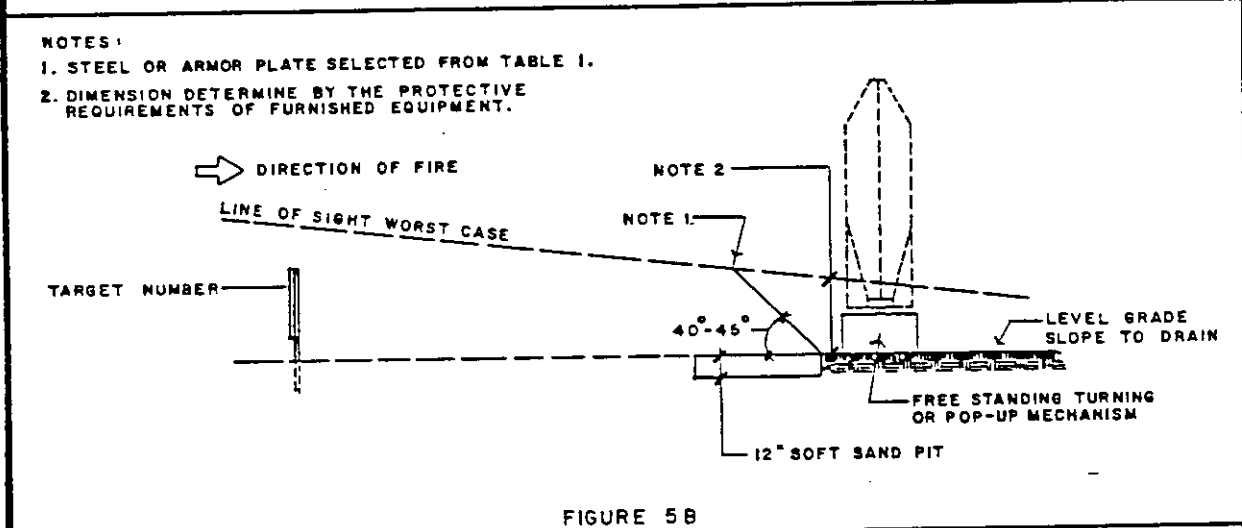
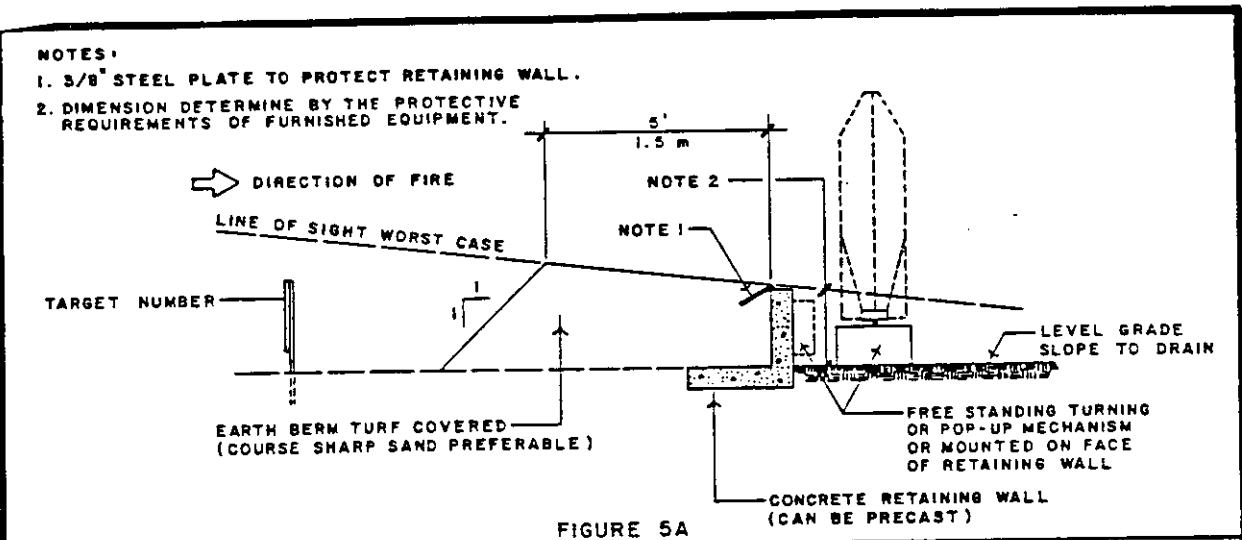

Figure 5

Ballistic Protection of Target Mechanism

MIL-HDBK-1027/3A

2.2.11.3 Pop-up Targets. Provide underground cable links and berms for device protection.

2.2.11.4 Fire Protection. Hydrants are desirable, if economically practicable. Provide fire extinguishers for fire fighting.

2.2.11.5 Utilities. Provide lighting in target storage and repair buildings, control tower, and electric power for loudspeaker systems used on the firing line. Provide power for night lighted ranges. Provide electric power for electric/electronic target and scoring systems.

2.2.11.6 Ready Ammunition. Provide protection shelter from sun and rain for ready ammunition. Provide access pathway or road for motor vehicles.

2.2.11.7 First Aid. Provide appropriate accommodations for first aid personnel and ambulance access. No additional structure is required.

2.2.11.8 Screening Area. Provide an area for screening brass and clips.

2.2.11.9 Additional Facilities. The following additional facilities should be provided, if possible and required by the user for range operations: parking area for vehicles; outdoor mess area (standup service); covered area for rain protection; and supply of water for drinking and sanitary use.

2.3 Rifle Ranges

2.3.1 Parallel Ranges. When laying out parallel ranges without use of separating walls or embankments, the safety arcs as shown in Figure 6 may be allowed to overlap; however, the safety arc may come no closer than 50 yds (46 m) to the target pits of an adjacent range. This will allow the changing of pit crews while the adjacent range is firing. To further reduce range spacing, a separating wall or embankment extending from the target pits to the most distant firing line may be used as shown in Figure 6.

2.3.2 Range Capacity. Refer to NAVFAC P-80 for calculating the number of firing points.

2.3.3 Firing Lines. Firing lines shall be sloped as shown in Appendix A, Figure A-9. The line of sight to targets shall be as nearly horizontal as practicable. Target centerlines should be above the firing point, but should not exceed 6 ft (1.83 m) on flat terrain. Individual firing points shall be spaced the same distance apart (center-to-center) as the target frames for known distance ranges (see Figure 7).

2.3.4 Target Frames and Carriers. Criteria for designing target frames and carriers for rifle ranges are defined in paras. 2.3.4.1 through 2.3.4.3.

2.3.4.1 Size. Target frames shall be 4 ft wide x 6 ft high (1.22 m x 1.83 m) for use up to 300 yd (274 m), and 6 ft² (1.83 m²) for use at distances greater than 300 yds (274 m).

2.3.4.2 Spacing. For distances up to 600 yds (548 m), space carriers 9 ft (2.7 m) on centers. For shooting at more than 600 yds, the Range Officer may specify that only alternating carriers be used.

MIL-HDBK-1027/3A

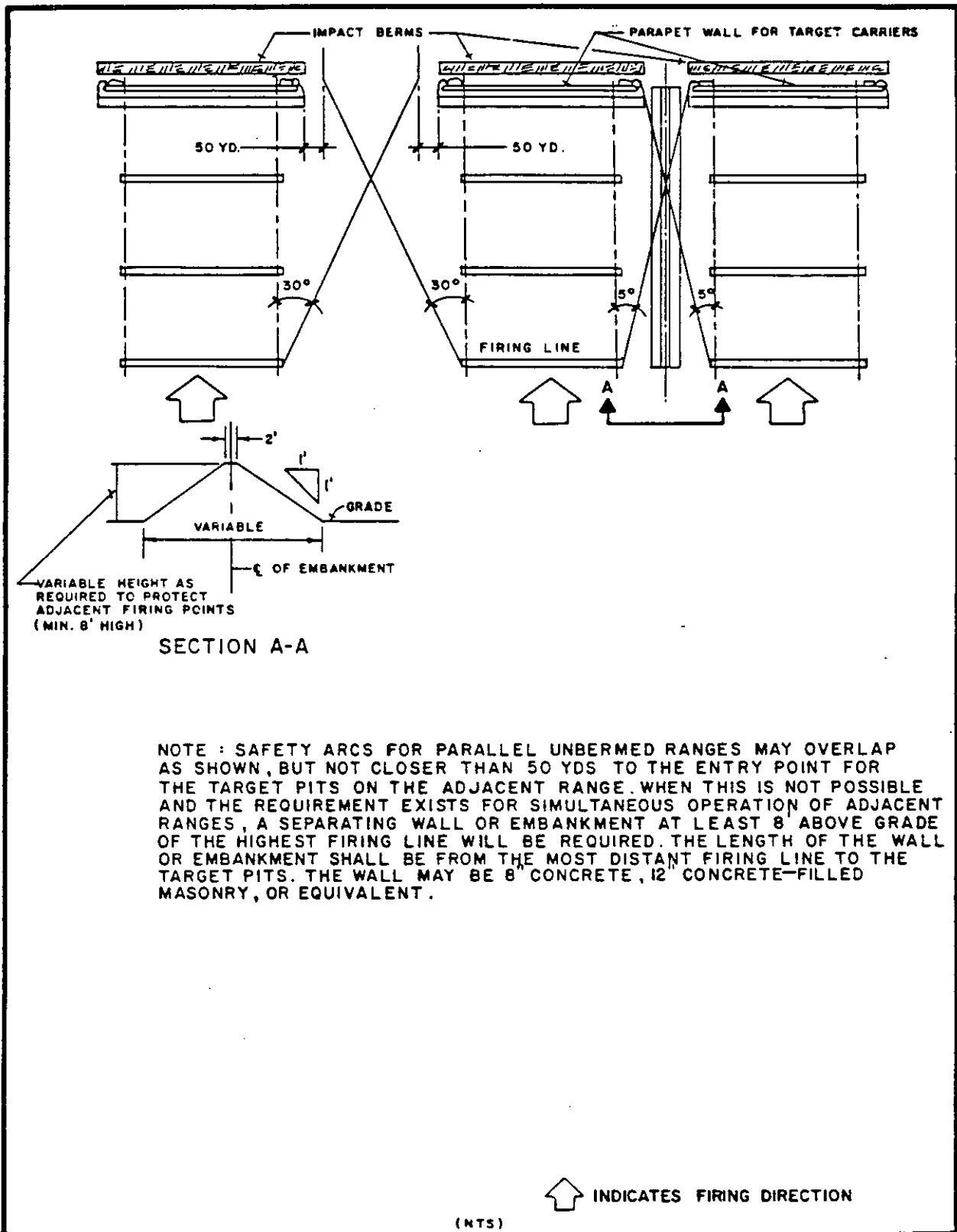

Figure 6

Parallel Ranges

MIL-HDBK-1027/3A

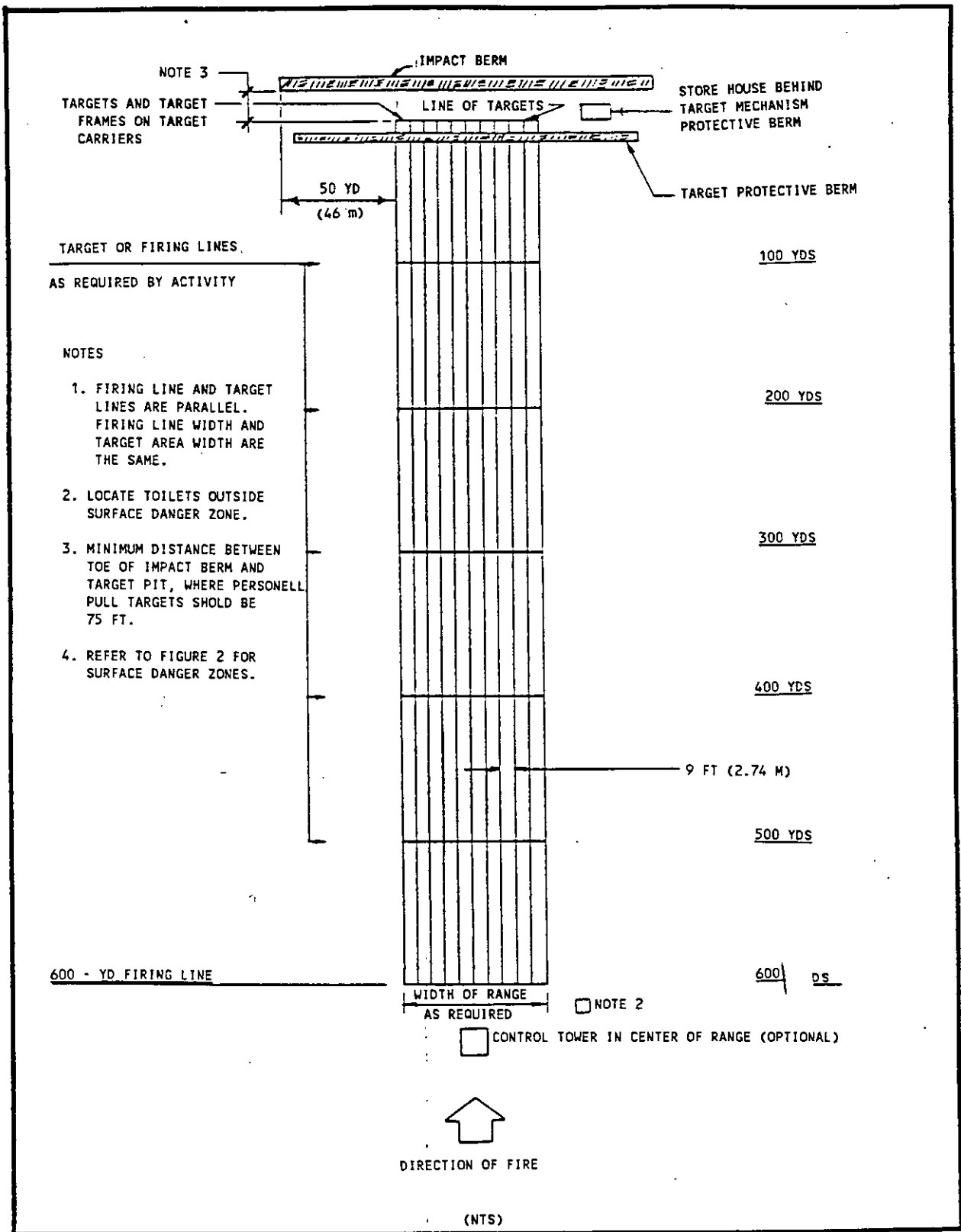

Figure 7

Outdoor Rifle Range Layout -- Open Range

MIL-HDBK-1027/3A

2.3.4.3 Construction Details. Refer to Appendix A, Figure A-1, for details of one box type target carriage assembly and target frame used on existing ranges. Refer to Appendix A, Figure A-2 for an acceptable type carrier system where butt space is available. Commercially available, electric motorized target carrier and an electronic scoring system should be considered where training personnel will not be available to operate the manual box type of target carrier system or to increase total personnel throughput by up to 50 percent without expanding the range. Full face of target must be visible from firing line in all firing positions.

2.3.5 Target Butts. For details of typical target butts, refer to Appendix A, Figures A-2, A-3, and A-4.

2.3.6 Storehouse and Toilets. Provide target storehouses and toilets at the ends of target butts. Base the size of toilet on two men per target. Additional toilets, as necessary, shall be provided at the flanks of the range, preferably behind the firing line. Use of portable toilets may be substituted for permanent toilets if acceptable for user requirements. If located downrange, the building/structure height must be below the level of the protective berm.

2.3.7 Bullet Impact Berms. Bullet impact berms are preferred at all new construction open ranges to reduce the number of bullets impacting into the surface danger zone and will be provided on fully baffled ranges as part of the baffle system to reduce the size of the surface danger zone. If siting will permit, the most economical backstop is a mountain, cliff, or steep hill. This will save the cost of constructing an earthen berm. The surface facing the firing line will have at least 3 ft (0.91 m) depth of soil, free of boulders, trees, rocks, stones, and other materials that will cause ricochets.

2.3.7.1 Earthen Impact Berm. The steeper the slope, the fewer bullets will ricochet into the area behind the impact berm. A 45 (1-to-1 slope) impact berm will absorb more bullets than a 33.5 (1-1/2 to 1 slope). The 1-to-1 or steeper slope is recommended. If this slope cannot be maintained, an engineered slope protection system may be used to satisfy local conditions, keeping in mind that the surface material must be able to be filtered periodically to prevent projectile build-up.

2.3.7.2 Height of Bullet Impact Berms. The impact berm for open ranges will rise a minimum of 20 ft (6.1 m) above the top of target when projected upon the berm. As illustrated in Figure 8, for overhead baffled ranges, the impact berm will rise a minimum of 20 ft (6.1 m) above the point of highest possible bullet impact. As shown in Figure 4, a combination berm/baffle arrangement is acceptable if the impact berm is otherwise adequate. With this arrangement, the berm will extend a minimum of 5 ft (1.52 m) above a point representing the top of the target when projected upon the berm for open ranges, or a minimum of 5 ft (1.52 m) above the point of highest possible bullet impact for overhead baffled ranges. Vertical baffles may be employed to provide the total of 20 ft (6.1 m) for ricochet capture protection. It is permissible to construct the vertical baffle to overhead baffle specifications if designed to contain bullets from the most powerful ammunition to be used on the range. The base of the earthen berm may be reduced by use of vertical retaining walls made with a double staggered row of earth-filled tires or other bullet absorbing material. The designer will determine at what height the cost of raising the earthen berms exceeds the cost of baffle construction.

MIL-HDBK-1027/3A

2.3.7.3 Bullet Catch. A bullet catch, as shown in Figure 8, positioned at a 90 degree angle to the front slope of the impact berm above, the point of bullet impact may be needed where the front slope of the impact berm because of local soil conditions must be less than 1 to 1.

An "eyebrow" ricochet catcher as shown in Appendix A, Figure A-5, will be needed in lieu of the plate bullet catch on a fully-baffled range when a 300 yd (274 m) surface danger zone (as shown in Figure 2e) does not exist and when bullets are leaving the range after striking the impact berm or side protecting berms.

2.3.7.4 Electronic Scoring Target Systems. An electronic target scoring system saves training and firing time by eliminating manpower to pull and mark targets and score helpers to record and maintain scores. Each shot is automatically located, recorded, scored, and displayed to the shooter/match official. A fully automatic system may eliminate the requirement for communication equipment. Each shooter controls his own firing lane, or all lanes can be controlled at a central location. Equipment normally includes target frame with acoustic chamber, firing lane control unit with printer at firing line, CRT monitor, firing sensor, projectile detector, and power units and transmission line.

2.4 Pistol Ranges. Baffle designs for outdoor pistol ranges (as well as rifle ranges) are shown in Appendix A, Figures A-6 and A-7. Criteria for designing pistol ranges shall be as given in paras. 2.4.1 through 2.4.8.

2.4.1 Surface Danger Zone. Site shall be large enough to provide the full area shown in Figures 2, 2a, 2b, or 2c for open range. This area may be greatly reduced as indicated in Figures 2d, 2e, and 3, by use of protective canopies and baffles as shown in Figure 4.

2.4.2 Number of Targets. Refer to NAVFAC P-80 for range capacity factors.

2.4.3 Spacing. Targets and firing lines shall be spaced as indicated in Figure 9. Firing points shall be elevated slightly above range grade. Full face of target must be visible from firing line in all firing positions.

2.4.4 Line of Sight. The line of sight shall be as nearly horizontal as practicable.

2.4.5 Bullet Impact Berms. Bullet impact berms for pistol ranges shall conform to the requirements of para. 2.3.7.

MIL-HDBK-1027/3A

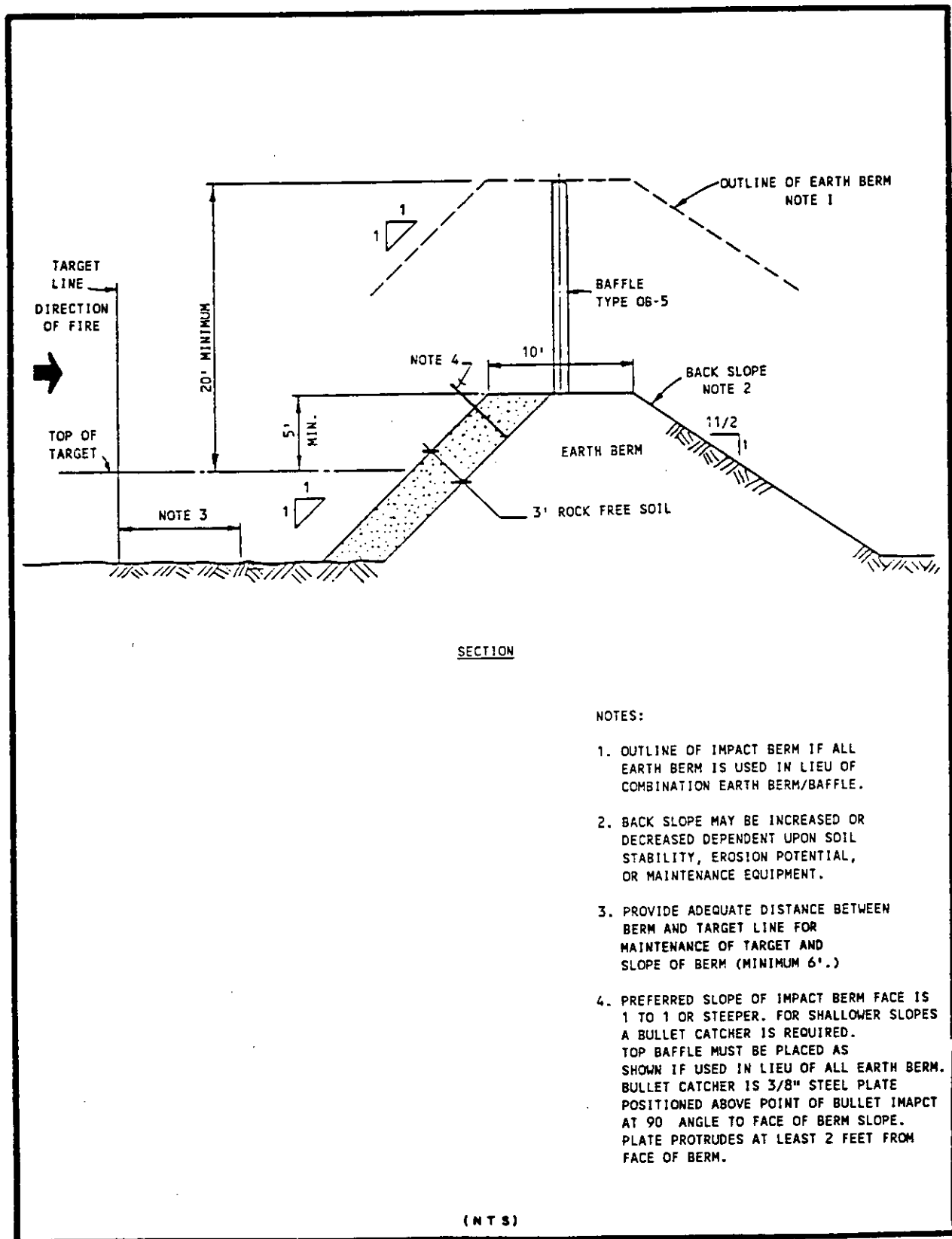

Figure 8

Impact Berm For Open Range and Baffled Range

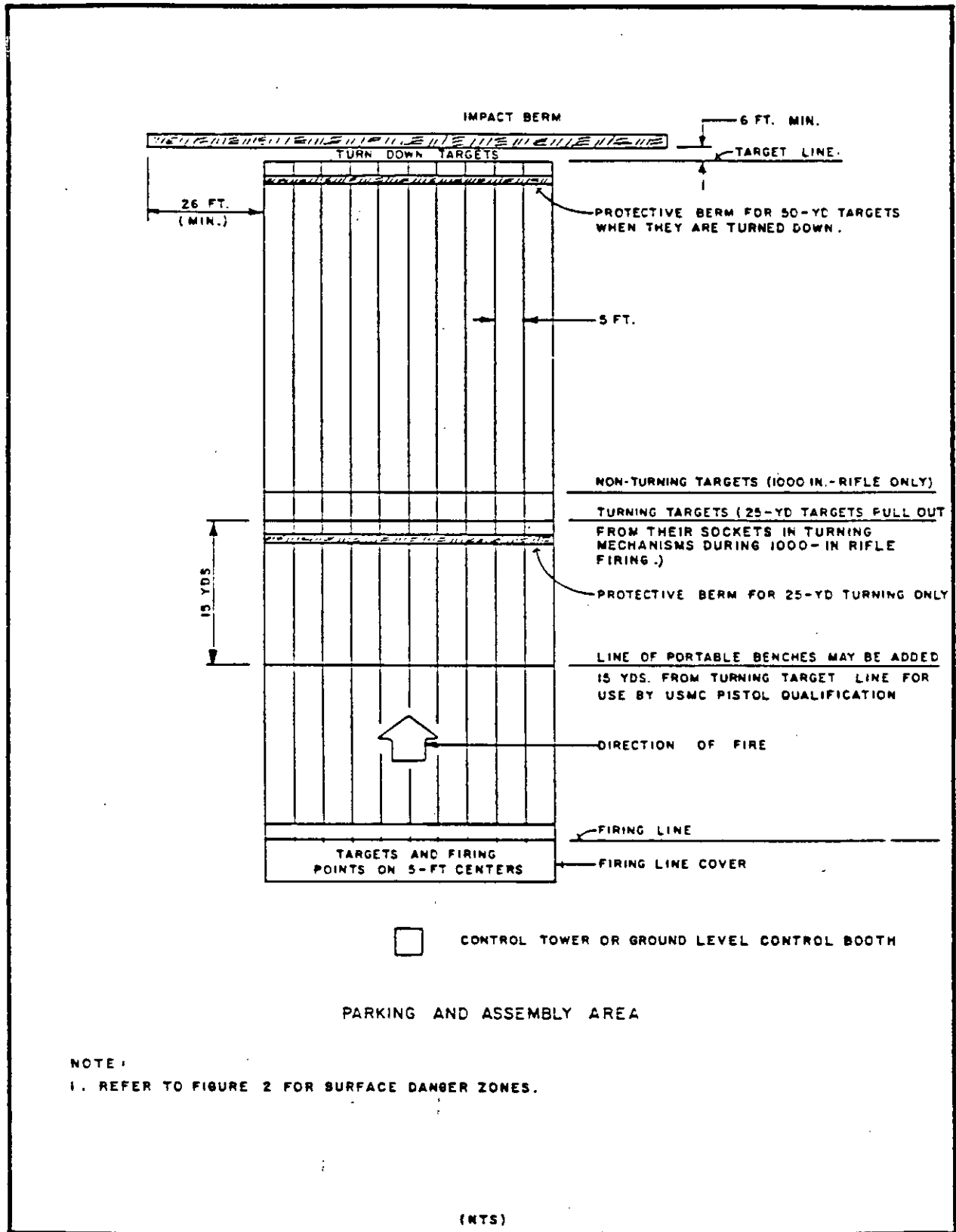

Figure 9

Outdoor Pistol/Rifle Range Layout -- Open Range

MIL-HDBK-1027/3A

2.4.6 Protective Canopies, Baffles and Side Berms. Canopies, baffles and side berms are designed to prohibit the escape from the range of any misdirected or accidental shots fired from the firing line in a downrange direction either upward or laterally, when sighting from 80 degrees left to 80 degrees right of the line of fire.

2.4.7 Other Facilities. Provide electric power, ready ammunition protection, first-aid station, drinking fountain, fire protection, and toilet facilities if required by user.

2.4.8 Close Combat Pistol Course

2.4.8.1 Minimum Area Required. A facility for a ten point firing range requires a square area at least 40-yd long and 40 yds wide (36.58 m). Provide for an assembly area and a ready line 10 yd (9.14 m) behind the 25 yd (22.86 m) firing line. Provide a 5-yd space (4.57 m) from the target face to the impact berm. Firing points will be 10 ft (3.05 m) apart; spacing less than 8 ft (2.44 m) apart is not recommended.

2.4.8.2 Firing Lines. A 36 in. (0.914 m) wide x 54 in. (1.37 m) high barricade is erected at each firing point at the 25 yd (22.86 m) firing line only. Additional firing lines are provided at 15, 10, 7, and 3 yd (13.7 m, 9.14 m, 6.4 m, and 2.74 m) lines.

2.4.8.3 Target Construction. Target frames are constructed of 1 in. (25.4 mm) x 2 in. (50.8 mm) wood. The target is 36 in. wide (0.914 m) x 45 in. high (1.14 m) set 28 in. (0.71 m) above the ground.

2.5 Protective Baffling for Small Arm Ranges

2.5.1 Geometry of Baffle System. The geometry of the baffle system shall be designed to minimize the chances of a projectile that is fired downrange from the firing line from leaving the range. Figure 4 shows the line of sight arrangement using vertical overhead baffles forward of the firing line. Baffles shall overlap line of sight by a minimum of 6 in. (152 mm). It is important that any baffle system be designed to not obscure the shooter's view of the entire target in both prone and standing firing positions. Additional baffles should be added downrange to assure that the bullet will impact the earth berm not less than 5 ft (1.52 m) from the top of the berm. Every overhead baffle beyond 200 yd (183 m) should be figured for the prone firing position. In certain cases total baffling may not be required. Generally baffles should be provided to the extent of protection required. In an overhead system the firing line should be fixed. On variable distance ranges the target lines are movable.

2.5.2 Firing Line Canopy Shield. The overhead baffle or canopy shield extends at least 12 ft (3.66 m) in front of the firing line. This distance will be increased depending upon the position of the muzzle of the weapon in the most critical firing position. Appendix A, Figure A-8, shows one type of canopy shield. Overhead baffle designs may be used as canopy shield if appropriate for the weapons and ammunition to be used.

2.5.3 Overhead Baffles. Overhead baffles shall be spaced in such a manner as to prevent a bullet from being fired out of the range provided that the weapon is fired downrange from the firing line. The overhead baffles will

MIL-HDBK-1027/3A

extend horizontally to within 1 ft (305 mm) of the surface of side berms or protective side walls. Overhead baffles may be of any design shown in Appendix A, Figure A-6, or Figure A-7, provided the design selected is appropriate for the weapons and ammunition to be used. Baffles will be designed to withstand local windloads. Range baffles and supports in relation to side berms or walls will be arranged to allow maintenance equipment access inside the range.

2.5.4 Ground Baffles. Ground baffles, normally on pistol ranges only, shall be designed to contain ground ricochets and bullets accidentally fired toward the ground. Ground baffles have caused some problems with training techniques at some activities and are not recommended for combat ranges where baffles present a greater hazard to personnel as a trip hazard than for control of ricochets. For pistol ranges, a ground baffle just in front of the 25 yd (22.86 m) and 50 yd (45.8 m) line of targets may be required to protect the target mechanisms. Figure 5 shows three methods of target mechanism protection in order of preference: below-grade mechanism trench; ground baffle; turf covered berm. These baffles should be just high enough to protect the target mechanisms. Because additional ground baffles add to range cost, they should not be added until other options to control ground ricochets have proven ineffective.

2.5.5 Side Berms or Protective Side Walls. Side protection may be in the form of earthen berms, continuous walls or wing walls. Wing walls are discontinuous side protection walls set at angles to the line of fire. Wing walls will be arranged and overlapped so that a shooter at any firing point cannot shoot through openings in side walls. Side berms and walls shall be a minimum of 8 ft (2.4 m) above grade at the highest firing point in order to protect inhabited areas or occupants of adjacent ranges from misdirected fire. When side walls or wing walls are combined with overhead baffles in a fully protected range, they will be at least as high as the top of the overhead baffle, but shall be designed to prevent the escape of any round that is fired from the firing line and also passes just under the bottom of the last downrange overhead baffle.

2.5.6 Multiple Firing Line Baffle Ranges. For the design of a multiple firing line baffling system, the same procedures and requirements should be followed as in the case of designing a single firing line baffle system except that the designing begins at the firing line closest to the backstop. Working back from that line, follow the same procedures outlined for a single firing line system. For a fully baffled system, a canopy shield must be provided at each firing line.

2.5.7 Fixed Firing Lines and Movable Target Lines. Commercial pop-up and turning targets are recommended where funding is available. Protective berms will protect the mechanisms (see Figure 5 for examples). Where short-range turning targets must be removable to enable shooting at a longer range target, consideration should be given to the various commercially available target transport systems.

2.5.8 Material Choices for Baffle Design. The construction of the baffled system shall be designed for ease of maintenance, economy of construction, availability of material, sound abatement, and prevention of ricocheting. Para. 2.1.3.6 and Figures A-6 and A-7 of Appendix A, provide material options.

2.5.8.1 Roof Structures. Roof canopies forward of the firing line will incorporate the firing line canopy shield and will be constructed at least equivalent to the overhead baffles. That portion of the roof back of the firing line may be normal roof construction and shall slope for drainage. Roof construction will incorporate sound reduction material if noise reduction is required.

2.5.8.2 Concrete Baffles. Concrete vertical overhead baffles may be precast or poured in place and shall be designed and clad with wooden covering to prevent ricocheting. A vertical unclad concrete overhead or ground baffle is susceptible to impact erosion. Unclad dense concrete set at 27 degrees or less with direction of fire will actually allow the bullet to travel along the concrete surface with little damage.

2.5.8.3 Composite Overhead Baffles. The use of wood and steel laminated baffles is permitted. Where only one steel plate is used, it must be capable of withstanding the most powerful cartridge normally fired on the range: .357 magnum for pistol ranges and 7.62 mm for rifle ranges. Single plate design will be faced with 3/4-in. (19 mm) exterior grade plywood. The plywood should be positioned to provide an air space of approximately 3/4 in. between the wood and steel plate. Another option, Type OB-5, using timber poles for support (see Appendix A, Figure A-7), is a steel plate faced with 3/4-in. exterior grade plywood and a second unsheathed plate behind it, separated by the diameter of the timber pole. The bullet tumbles as it passes through the first plate and is stopped by the second plate. The two plate design using 1/4-in. (6.35 mm) steel is suitable for 7.62 mm, 5.56 mm, and 30 cal. (30-06) Ball ammunition.

2.5.8.4 Wood Baffles. Wood in wood baffles shall be a minimum of 2 1/2 in. (63.5 mm) in actual thickness. Each layer of wood in all wood baffles will be laid at right angles to the adjoining layer. Joints in each layer will be staggered in relation to joints in adjoining layers, to prevent the penetration of projectiles at the joints. (See Appendix A, Figure A-6, for wood and wood combination panels.)

2.5.8.5 Protection of Structural Members. Wood will be applied to wood structural members and shall be of adequate thickness to prevent damage to the structure by the penetration of projectiles. The outer layer of wood must be readily replaceable after projectile damage. The damaged outer layer may be covered with a new layer of wood to eliminate the cost of removal of damaged layers and to further protect structural members. Structural members in wooden overhead baffles may be further protected with plate metal behind the outer wood layer. Wood of 3/4-in. (19 mm) minimum actual thickness, or commercial baffle specifically designed for the purpose, positioned to provide approximately 3/4-in. interface airspace will be applied to steel and concrete baffle support posts to reduce ricochets and support damage.

2.5.8.6 Grade of Lumber. Material for firing side of all baffles will be middle grade lumber; pine, oak or redwood is acceptable. Exterior grade plywood will be acceptable for baffle construction. Exceptionally hard or knotty wood shall not be used. Material on the back side of baffles may be of lower grade or higher density. Preservative treated lumber will be used in the construction of wood baffles. Wood posts in ground contact shall be pressure treated with preservatives and stamped for use in ground contacts or below ground.

MIL-HDBK-1027/3A

2.5.8.7 Material Connectors. Metal connectors for structural members, fasteners and bolts larger than 1/4 in. (6.35 mm) within 25 yards (22.86 m) of the firing line must be recessed and covered to prevent striking by projectiles and ricochets.

2.5.8.8 Side Berms or Protective Side Wall Construction. Side berms or protective side wall construction is designed to contain bullets accidentally fired to either side of the range. Side protection may be of various materials and material combinations. Wood, earthen berms, 8 in. (203 mm) poured concrete, and concrete block construction may be used. Concrete block walls used for side protection shall be hollow core and a minimum of 12 in. (304.8 mm) thick. The cavities of the concrete blocks shall be filled with concrete or gravel. Downrange when the angle to fire line is approximately 27 degrees to direction of fire, precast concrete panels without cladding may be used to deflect ricochets back into the range.

Other designs will be acceptable, such as 8 in. (203 mm) heavy timber or laminated wood or steel panels matching overhead baffles if steel plate in the panels is appropriate for weapons and ammunition to be fired.

2.5.8.9 Berm Construction. Embankments will be constructed of approved fill materials for the locale. The front of the berm facing the inside of the range shall have 3 ft (0.914 m) of rock-free material. Periodic maintenance of the face of the berm is essential. Danger of backsplatter and ricochet increases as accumulation of lead increases. Fill shall be placed in layers and compacted to minimize erosion. The requirements of para. 2.3.7 shall be adhered to.

2.6 Machinegun Ranges. The standard firing distance is 25 meters. The M-16 and the .22 caliber rifle may also be fired on the machinegun range.

2.6.1 Surface Danger Zone. Provide an open range surface danger zone as indicated in Figures 2, 2a, or 2b.

2.6.2 Targets

2.6.2.1 Stationary Targets. Stationary targets shall be spaced in the field to suit local conditions and training requirements.

2.6.2.2 Moving Targets. One type of rolling target is shown in Appendix A, Figure A-10. Other types are commercially available and should be considered in making the layout. Targets will be engaged within specified limits. Bullet impact berms and vertical baffles must cover all shots within these limits.

2.6.3 Salvage Wall (Impact Berm). A cut slope or hillside should be used to the rear of the targets as a salvage embankment when available, or an earth impact berm will be provided as shown in Appendix A, Figure A-10. Newly constructed machinegun ranges will have either a salvage wall or a salvage wall and an impact berm.

2.6.4 Storehouse and Toilet. If a target storehouse and toilet are not located nearby, they should be placed adjacent to the range.

2.6.5 Other Facilities. Provide electric power, protected ready ammunition, and a first aid station. Refer to para. 2.3 for criteria.

MIL-HDBK-1027/3A

2.7 Composite Small Arms Ranges. Where site conditions permit, rifle, pistol and machinegun ranges should be located close to each other. If necessary for use, composite ranges may overlap under controlled conditions. Common support facilities may then be located for convenient use by personnel on all ranges (refer to Section 3).

2.8 Shotgun Ranges. Criteria for shotgun ranges shall be as defined in paras. 2.8.1 through 2.8.3.

2.8.1 Surface Danger Zone, Riot Gun Ranges. For design criteria, see Figure 6-3 of MCO P3570.1A, Policies and Procedures for Firing Ammunition for Training, Target Practice, and Combat, for firing 12-gauge riot guns using cartridges loaded with 00 buckshot or smaller.

2.8.2 Maximum Range. Refer to Table 4 for riot gun ranges.

2.8.3 Skeet and Trap Ranges. Refer to NAVFAC P-457, Planning and Design of Outdoor Sports Facilities, for electrically operated skeet and trap ranges. Design for 12-gauge, shot size 7-1/2, 8, or 9 standard and reduced loads. In accordance with NRA references, the maximum range for 7-1/2 shot is 740 yd (676 m), for 8 shot is 720 yd (658 m) and for 9 shot 670 yd (613 m). Magnum loads of any size and shot sizes heavier than 7-1/2 are prohibited. This range may be used to teach shotgun marksmanship.

2.9 Combat Marksmanship Course. Design the combat marksmanship course for a five-man team, or as determined during range planning phase.

2.9.1 Targets. Equip the course with electrically controlled pop-up targets, spaced intermittently throughout a course length of approximately 300 yds (274.3 m).

2.9.2 Control Tower. Provide a control tower of adequate height to observe targets and personnel using the course. Equip the tower with a control board to regulate the operation of the targets.

2.9.3 Power. Provide electric power and furnish a subsurface duct to carry electrical wiring from control tower to target manholes.

2.9.4 Target Storage. Provide a storehouse for targets, and manholes to house pop-up targets.

2.10 Protection of Personnel. Refer to Table 5 for protection of personnel against individual hits of small-arms and for required thicknesses of cover. These thicknesses will not provide positive protection against continued burst firing.

Section 3: COMMON RANGE FACILITIES

3.1 Siting. Range geometrics and surface danger zones given in the design manual reflect ideal siting. Small arms ranges require point targets and prepared firing positions. Heavy weapons ranges are area oriented, have longer distances, and require mixed targets in target areas. Combining the use of surface real estate and joint use of support facilities in conjunction with a range complex or new weapons on existing range must be considered on an individual basis. Common impact areas and overlapping surface danger zones of adjoining ranges may be allowed if weapons system characteristics are compatible and training requirements are not compromised. As an example, artillery firing points should not be located adjacent to rifle ranges as the noise detracts from live-fire training. The station Explosive Ordnance Disposal (EOD) officer and the Safety Officer must be included in any discussion of impact area safety. Guidelines for siting ranges are as defined in paras. 3.1.1 through 3.1.6.

3.1.1 Location. Safety is the prime consideration in locating a range. The characteristics and ballistics of the weapons systems for which the range is designed determine the selection of the site. The use of training ammunition versus use of service ammunition will determine size of area required. Range design objective is to contain the firing ammunition and explosives within the range real estate during training and target practice. The locations of the firing points, impact areas, and surface danger zones for the weapons to be used must be laid out to form a ground footprint on the station maps. Then the aerial easements, approach altitudes, and run-in lines for aircraft ranges must be superimposed on the ground footprint to confirm appropriate siting. Determine acceptable noise levels on adjacent inhabited areas. Consider the added risk of accidental misdirected firing into adjacent areas.

Locate aircraft ranges and gunnery ranges so that firing and impact areas are at least the same distances from ammunition and gasoline storage as is required for inhabited buildings. Where available areas are limited, these distances may be reduced to that required for public highways. For purposes of maintaining safe distances, routes for public land and areas of intermittent public use (such as cemeteries, outdoor recreational areas, and private utilities) shall be treated the same as inhabited buildings. Navigable waterways and railroad lines shall be treated the same as public highways. For required Explosive Safety Arcs from inhabited areas and public highways, refer to NAVFAC P-80 and NAVSEA OP-5, Ammunition Ashore Handling, Stowing and Shipping.

Surface danger zones must be under U.S. Government control. If not under total Government control, area access shall be limited to prescribed times for commercial activities such as fishing, grazing or mining, or firing shall be limited to prescribed times.

Selection of the site will also consider the following:

a) The effect that range construction and range operation will have on endangered species of wildlife (if any) and on proper land use policies.

b) Preservation of important survey monuments in the area, especially those of U.S. Coast and Geodetic Survey.

- c) Common use of roads, messhalls, other training facilities applicable to several ranges.
- d) Decontamination of unexploded ordnance and cleanup of inert debris.
- e) Target setup, maintenance, and repair.

3.1.2 Orientation. All firings shall be conducted in a direction away from ammunition and gasoline storage and inhabited areas. Trajectories shall not pass over an ammunition or gasoline storage area. Orient the range so that gunners will not be firing into rising or setting sun.

3.1.3 Terrain. Firing into upward sloping land and land with natural backstop of hills or mountains is recommended. Land with good natural drainage and which is mostly barren of ignitable grass, timber, and underbrush is preferable. Firing platforms, access and range roads, and targets are to be elevated above flood level. The line of fire in rough terrain should be perpendicular to high ground. The line of fire on flat terrain should be free of knolls, ridges, and trees which reduce visibility. Known distance ranges should be as horizontal as possible. Firing points may be below the target provided the grade between the points and target does not exceed two percent. Ricochet cannot be completely eliminated, but can be reduced by level terrain, soft soil, and elimination of hard objects. For heavy weapons, impact areas must be clear of target debris and old projectiles. Earth berms should be used to the rear of target areas. Earth berms may be used on sides of the range to protect timber, game, recovery metal salvage, and possible reduction of impact areas.

Roads used for setting and servicing targets in impact areas and for maintenance of earth berm slopes may be graded pathways. Roads in areas not subject to disturbance such as vehicle parking area, projectile weapons firing and maneuvering areas, and roadways behind firing line or out of range of weapons, will be improved road of compacted subbase with compacted gravel base, or compacted gravel or crushed stone on compacted cement or asphalt stabilized sand, designed for anticipated vehicle weight and usage. Layout for tank trails and roads for other heavy tracked or lugged vehicles should be planned to avoid damage to improved roadway surfaces.

3.1.4 Access and Range Roads. Provide access roads for transporting personnel, supplies, and equipment to ranges and to service targets within target areas. Refer to NAVFAC DM-5.4, Pavements, and DM-5.5, General Provisions and Geometric Design for Roads, Streets, Walks, and Open Storage Areas, for criteria for pavements and roads. Access roads to aircraft weapons ranges will be run diagonal to the aircraft run-in lines.

3.1.5 Restricted Area Airspace. For restricted area airspace criteria to be applied to target and range requirements for aircraft weapons, refer to NAVFAC P-80. Requests for designation, alteration, establishment, or revocation of special use airspace shall follow the procedures outlined in OPNAVINST 3770.2G, Airspace Procedures Manual. The Federal Aviation Act of 1958 charges the Federal Aviation Administration (FAA) with ensuring the safe and efficient use of the nation's airspace by military as well as civilian aviation.

MIL-HDBK-1027/3A

3.1.6 Range Design Review. Range facilities shall be built in accordance with current safety standards at time of design. This is particularly important because of new weapons constantly coming into the weapons arsenal and personnel training is often performed on existing ranges developed for older weapons and ammunition. Where existing range construction and surface danger zone characteristics are not in conformance with design criteria requirements, range evaluation and design recommendations may be obtained by requesting assistance from COMNAVFACENGCOM.

3.2 Security. Provide manned or unmanned barriers to prevent passage of personnel or vehicles through the range during operation. Display red flags during firing and provide blinking red lights to supplement red flags at night. Install signs warning of danger, trespassing, and removal of items on ranges. Include security precautions for areas made hazardous because of jettisoned casings and links from aircraft firing at ground targets. Coordinate range security with explosive ordnance removal operations. At remote or unmanned equipment installations, security fencing may be necessary to protect against vandalism and trespass. When security fencing is required, refer to NAVFAC DM-5.12, Fencing, Gates, and Guard Towers.

3.3 Support Facilities. Facilities which may be common to all ranges include the following:

- a) Targets (expendable, not part of design criteria).
- b) Target storage.
- c) Bunkers, trenches, and protective barriers for protection of personnel.
- d) Range control towers.
- e) Firing and maneuvering platforms for heavy weapons.
- f) Toilets.
- g) Range poles, banners, markers, and signs.
- h) Communications systems.
- i) Boat docks for water target areas.
- j) Access and range roads.
- k) Parking areas.
- l) Bivouac facilities.
- m) Potable water.
- n) Demolition facilities.
- o) Range grounds maintenance equipment.
- p) Target maintenance.

MIL-HDBK-1027/3A

q) Ammunition supply and service facilities. For arms and ammunition storage requirements refer to OPNAVINST 5530.13, Physical Security Instruction for Sensitive Conventional Arms, Ammunition and Explosives, and MIL-HDBK-1013/1, Physical Security of Fixed Land-based Facilities.

r) Vehicle service facilities.

s) Fire protection.

t) First aid-ambulance emergency service.

3.4 Design of Support Facilities

3.4.1 Illumination. If the ranges are used for night training, provide illumination for the aiming points and operational instruments, such as target rakes and plotting boards (if scoring is manual).

3.4.2 Utilities. Utility designs shall conform to the requirements of NAVFAC DM-3.01, Plumbing Systems; MIL-HDBK-1004/1, Preliminary Design Considerations; and DM-5.03, Drainage Systems.

3.4.2.1 Electric Power. Where commercial power is unavailable, power generation equipment shall be provided.

3.4.2.2 Water Supply. Potable water is desirable at ranges and other training facilities; however, water supply provisions will be a site and project specific consideration. All water supply development should consider criteria contained in MIL-HDBK-1005/7, Water Supply Systems.

3.4.3 Structural Design. The design of structures required for ranges shall conform to the applicable sections of NAVFAC MIL-HDBK-1002/1, Structural Engineering General Requirements.

3.4.4 Mechanical Requirements. Refer to NAVFAC DM-3.03 for mechanical requirements criteria.

MIL-HDBK-1027/3A

Section 4. AIRCRAFT WEAPONS RANGES

4.1 Descriptions. Aircraft weapons ranges will be designed to provide areas and facilities for the training of air crews in gunnery, bombing, rocketing, missile delivery, strafing, mine laying, and close air support. Distances related to aircraft weapons ranges are given in nautical miles.

4.1.1 Restricted Area. This is an airspace identified by an area on the ground and prescribed height within which the flight of aircraft, while not wholly prohibited, is subject to restriction.

4.1.2 Surface Impact Area. The surface impact area is designated for the impact of ordnance material. Trespassing is prohibited in this ground because of imminent danger. The impact area is within the approved surface danger zone which contains impact areas, appropriate ricochet areas, and secondary danger areas (when required) which are located around the impact area and are provided to contain ricochet projectiles and fragments from items exploding or ricocheting on the edges of the impact area.

The size of the appropriate surface danger zone will be determined during the planning phase. The surface danger zone must be under U.S. Government control. There are differing safety problems for inert and live ammunition and explosives on a design project. On live fire ranges, the handling of duds affects range clearance, setting of targets, and types of targets.

4.1.3 Water Danger Area. This is an area of water in which all craft operating on or beneath the surface, while not wholly prohibited, are subject to restrictions.

4.1.4 Air Space Requirements. The limitation on usable airspace is a major factor in planning aircraft weapons ranges. Area requirement is based on the operational requirements for aircraft to complete firing runs involving time and speed, target towing and tow-track deviation, projectile envelope, and safety buffer zone. The restricted airspace established for the range must be coordinated through the Navy representative to the FAA in the cognizant region in accordance with OPNAVINST 3770.2G.

4.1.5 Ricochets. Inert training weapons including rockets and bombs, pose problems that full-scale weapons usually do not. An inert weapon creates ricochet problems when the missile hits the ground at shallow or flat impact angles. One type of practice bomb includes water-sand fills that simulate the size, weight, and shape of general all-purpose bombs. The heavier Bomb Dummy Unit (BDU) may be 500 to 2,000 lb (227 to 909 kg) and after initial impact, the BDU still has most of its impact velocity. When defining the safe area where release of the heavy inert general purpose bombs is planned, the ricochet potential may dictate the deciding distances.

There is little documentation on ricochet phenomenon except from certain weapons testing ranges (usually larger than air crew training ranges). Information received from Naval Weapons Center, China Lake, CA, is as follows: For 20 mm ammunition fired at 10 to 30 degree attack angle on air-to-ground targets where the target area contains rock, boulders, hard pan, or where targets are hard, such as armored tanks, the maximum expected downrange ricochet distance is 12,000 ft (3,657.6 m) from center of target,

the maximum expected side-range ricochet distance is 4,000 ft (1,219.2 m), from center of target, and maximum expected ricochet height is 3,500 ft (1,066.8 m).

Where the target area is loose sand, soft clay or a material that is free from rocks, boulders, and large quantities of spent ammunition, the maximum expected downrange ricochet distance is 9,000 ft (2,743.2 m) from center of target, the maximum expected side-range ricochet distance is 2,700 ft (823 m), and the maximum expected ricochet height is less than 3,500 ft. Current information should be obtained when designing ranges. The use of frangible bombs has been tested, but economic or other factors may preclude their general use on all ranges.

4.2 Siting. Aircraft ranges should be located within a maximum 100 mi (160.9 km) distance from the supporting air installation.

4.3 Strafing Range. A strafing range is used for air-to-ground firing of aircraft weapons such as 20 mm automatic cannon.

4.3.1 Site. The strafing range shall consist of a restricted airspace with a minimum radius of five nautical miles, and a surface-impact area measuring 1 by 1/2 mi (1.6 km by 0.8 km) located in the center of the restricted area. See Facility Plate No. 179-10, Sheet 1, for strafing range. The restricted airspace is needed to encompass the flight pattern of high-speed jet aircraft during approach, recovery, and circling for new approaches to the target. The surface impact area should be sited in all areas approved by station ordnance officer and in a remote location where ricochets, strays, and falling brass and links will not jeopardize surrounding property or personnel. Periodically sanitizing the impact areas is required maintenance.

4.3.2 Targets. Design criteria for strafing targets vary according to local training programs. See Facility Plate No. 179-10, Sheet 2, for acoustiscore strafing target. Targets may consist of automatic recording targets, simulated gun emplacements, aircraft, or portable target panels. For a typical strafing target, see Facility Plate No. 179-10, Sheet 3.

4.3.2.1 Cease-Fire Point. A cease-fire point for strafing runs shall be indicated either by a 15 x 600 ft (4.57 x 183 m) white "foul" line on the ground or by pylons (with height and color readily visible to pilots) spaced 600 ft apart. The foul line or pylons shall be on a line projected from the control tower and perpendicular to the aircraft run-in line.

4.3.2.2 Target. The target proper shall be located at the center of the surface impact and shall be placed 1,200 ft (365.7 m) behind the foul line and on its perpendicular bisector.

4.3.2.3 Run-in Line. The run-in line shall be marked between the foul line and the target by placing a 2 ft wide (0.61 m) stripe on the ground along the perpendicular bisector. The stripe may be broken with alternate 100 ft (30.48 m) lines and 50 ft (15.2 m) spaces.

4.3.3 Control Tower. The control tower shall be situated so that unobstructed vision of the target area and of the aircraft using the range is assured. The tower floor shall be at least 15 ft (4.57 m) above the ground

MIL-HDBK-1027/3A

and shall provide adequate weather protection for operating personnel and equipment. Provide the control tower with a water supply system, sanitary facilities and storage space for maintenance equipment. Air conditioning may be necessary for equipment, if not for human comfort. Locate the tower 1,000 ft (304.8 m) from, and on a line perpendicular to, the run-in line. The perpendicular line will be located 1,200 ft (366 m) ahead of the target.

4.3.4 Equipment. The control tower shall be equipped for two-way radio communication with aircraft and with telephone or radio communication with the supporting station, and shall house the recording portion of the remote scoring device so that information regarding hits can be relayed to the pilot.

4.4 High-Altitude Level-Bombing Range. The high-altitude level-bombing range provides facilities for pinpoint bombing at altitudes up to approximately 50,000 ft (15,240 m) in level flight, with or without altitude maneuvering devices.

4.4.1 Site. The high-altitude level-bombing range shall comprise a restricted area having a minimum radius of 5 mi (8.05 km) and a central surface impact area with a radius of 3 mi (4.8 km).

4.4.2 Targets. Criteria for designing targets are described in paras. 4.4.2.1 through 4.4.2.5.

4.4.2.1 Aiming Point. Locate the aiming point to provide a line of sight from an aircraft 10 mi (16.09 km) away, approaching at an altitude of 50,000 ft (15,240 m).

4.4.2.2 Pyramids. Provide and locate mobile radar-reflective pyramids for offset-bombing exercises at established geographic positions as required by local range operations.

4.4.2.3 Clear Area. Provide a clear area having a radius of 1,500 ft (457.2 m) with the aiming point as its center. The area shall be free from vegetation and topographic features that can obstruct visibility from the control tower and from spotting towers.

4.4.2.4 Typical Aiming Point. A typical aiming point is a solid-white circular area on the ground, the size of which varies as visibility requirements change. Illuminate the aiming point for night training.

4.4.2.5 Trailer. The range area should also contain suitable locations for a radar-reflective trailer to be placed up to 10 mi (16.09 km) from the target for use as an offset aiming point in offset-bombing exercises.

4.4.3 Initial Points. The initial points of aim shall be radar-reflective pyramids, either fixed or mobile, depending on local requirements, and shall be elevated above any vegetation or obstruction so as to be clearly visible to pilots of approaching aircraft. A typical initial point should be pyramid shaped, of frame construction, painted international orange, 6 ft high (1.83 m) with a 6 ft² base (0.56 m²). (See Facility Plate No. 179-10, Sheet 4).

4.4.4 Control Tower. Locate the control tower outside the 3 mi (4.8 km) radius of surface impact, on a line projected through the aiming point, and perpendicular to the primary run-in line. Requirements for the control tower

MIL-HDBK-1027/3A

shall be the same as those for the strafing range control tower.

4.4.5 Spotting Towers. Where remote spotting devices are not used, two spotting towers are necessary. Spotting towers shall meet the same requirements as the control tower regarding elevation, visibility, weather protection, and distance from the aiming point. The spotting towers on Weapons Impact Scoring Set (WISS) instrumentation ranges will contain cameras and will be unmanned.

4.4.6 Equipment. Criteria for equipping the control tower and spotting towers are given in paras. 4.4.6.1 and 4.4.6.2. The designer should request appropriate Commander, Space and Naval Warfare Systems Command (COMSPAWARSSYSCOM) criteria from the user for radio and telephone communication provision to be included.

4.4.6.1 Communication. Where a remote controlled spotting device is used, the control tower shall be equipped with two-way radio communication with aircraft, and with telephone or radio communication with the supporting station, and electronic equipment to record the position of bomb impacts. When manned spotting towers are used, the control tower shall be provided with additional equipment to provide telephone or radio communication to the spotting towers.

4.4.6.2 Range Instrumentation Equipment. The control tower may serve as the command and control center for the range or range complex. It may house the equipment to integrate all electronic scoring, data management, and communication with the air crews. The unmanned spotting towers will contain closed circuit television cameras remotely operated, sending signals to the control tower.

4.5 Multipurpose Target Range. The multipurpose target range is used for training in conventional dive bombing, high-altitude dive bombing, glide bombing, strafing, and in firing air-to-ground 2.75 (FFAR) folding fin aircraft rocket, or 5.0 FFAR Zuni rockets. Inert training weapons are normally used with small charges to facilitate spotting. See Facility Plate No. 179-10, Sheets 5 and 6, for Multipurpose Target Ranges.

4.5.1 Site. The range shall consist of a restricted area with a minimum radius of 5 mi (8.5 km) and a surface impact area with a radius of 1-1/2 mi (2.41 km) in the center. See Facility Plate No. 179-10, Sheet 6, for Multipurpose Range.

4.5.2 Targets. Provide a clear area having a radius of 1,500 ft (457.2 m), with the aiming point as its center. The aiming point shall be a solid white circular area on the ground with a radius of 10 ft (3.05 m). There shall be a method of illuminating the aiming point for night training. The area shall be fully visible from the control tower and spotting towers. See Facility Plate No. 179-10, Sheet 7, for Multipurpose Target and Facility Plate No. 179-10, Sheet 8, for Alternate Multipurpose Target. For an alternate rocket target, see Facility Plate No. 179-10, Sheet 10.

4.5.3 Initial Points. Depending on local requirements, initial points of aim shall be either fixed or mobile. When visual reference is necessary, the point shall be elevated above any vegetation or obstruction so as to be clearly visible to approaching pilots for a distance of 5 mi (8.5 km). Each range shall have available a supply of both radar-reflective and nonreflective

MIL-HDBK-1027/3A

initial points.

4.5.4 Flight Path Markers. The flight path may be marked at 500 ft (152.4 m) intervals for 3,000 ft (914.4 m) on either side of the aiming point. The markers may be 5 ft² (0.46 m²) whitewashed rock or three, painted, earth-filled oil drums lashed together.

4.5.5 Control Tower. The control tower shall conform to the requirements for the strafing range control tower. Locate the tower a minimum of 4,000 ft (1,219.2 m) (6,000 ft (1,828.8 m) is desirable) from the aiming point and on a line projected through the aiming point perpendicular to the primary run-in line.

4.5.6 Spotting Towers. The spotting towers shall meet the same requirements as the control tower regarding elevation, vision, and weather protection. Criteria for spotting towers requirements are described in paras 4.5.6.1 and 4.5.6.2.

4.5.6.1 Air-to-Ground Range. Two spotting towers for the rocket range will be located on a line perpendicular to and 1,500 ft (457.2 m) on each side of the flight path. The perpendicular line will be located 1,500 ft ahead of the target.

4.5.6.2 Bombing Ranges. Two spotting towers will be located a minimum of 4,000 ft (1219.2 m) from the target and approximately equally spaced from each other and the control tower.

4.5.7 Rake Shacks (For Manual Scoring). Locate two rake shacks as shown for spotting towers in Facility Plate No. 179-10, Sheet 5, for rocket bombing target.

4.5.8 Dive Bombing Range. Multi-target flight path is shown in Facility Plate No. 179-10, Sheet 11. See Facility Plate No. 179-10, Sheet 12, for dive bombing range. The target for minimum altitude release is shown in Facility Plate No. 179-10, Sheet 13.

4.5.9 Equipment. Criteria for equipping the control tower and spotting towers are described in paras 4.5.9.1, 4.5.9.2, and 4.5.9.3.

4.5.9.1 Communication. Provide two-way radio communication with aircraft, telephone communication with the spotting towers, and telephone or radio communication with the supporting station.

4.5.9.2 Plotting and Recording (For Manual Scoring). Provide a dive-angle "harp" to obtain data during dive-bombing exercises, a theodolite or target rake for measuring the angular displacement of the bomb impact from the target center, and a plotting board for marking impacts as they are called in from the spotting towers. Equip each spotting tower with a target rake and a telephone for reporting to the main control tower.

4.5.9.3 Electronic Scoring. Refer to High-Altitude Level-Bombing Range for equipment for a WISS instrumentation range.

4.6 Loft-Bombing Range. Loft-bombing enables a pilot to release a bomb in such a manner as to loft it, thus gaining time for the aircraft to escape from the impact area at low altitude. The loft-bombing range is highly

instrumented for practice bombing with simulated nuclear weapons and other conventional weapons. The loft-bombing range provides training in self-protection against nuclear-weapon effects (and special conventional weapons), detection, and retaliatory ground fire. This facility is used for training in the low-level delivery of special weapons, and is to include loft, toss, and over-the-shoulder techniques. See Facility Plate No. 179-10, Sheet 14, for Loft-Bombing Range.

4.6.1 Site. The loft-bombing range comprises an extensive area.

4.6.1.1 Restricted Airspace. The restricted airspace includes a five mile radius from target center, from surface to 24,000 ft (7,315.2 m) above target, and multiple approach corridors extending 25 mi (40 km) from target center. A 6 mi (9.66 km) width is required when alternate left or right escape maneuvers are performed. Clearance above the corridors is 3,000 ft (914.4 m) for the first 10 mi (16.1 km) of the approach, 5,000 ft (1,524 m) for the next 8 mi (12.8 km), and 9,000 ft (2,743.2 m) for the remaining two miles to the airspace cylinder around the target center. See Facility Plate No. 179-10, Sheet 15.

4.6.1.2 Impact Area. The surface impact area has a minimum radius of 1-1/2 mi and is centered on the target.

4.6.1.3 Single-Direction Approach. The requirement for a single-direction approach to the target is a rectangular area one mile wide by 20 mi (32 km) long, preferably having its length aligned with the prevailing wind. This area is necessary to encompass the approach, pullup, and recovery of high speed jet aircraft using the range. See Facility Plate No. 179-10, Sheet 16, for flight path profile. The first 10 mi (16.1 km) of this primary approach lane is to permit speed stabilization of the aircraft before beginning the actual bombing run. The second 10 mi (16.1 km) of the primary approach is for recorded practice bombing runs, which necessitate installation of instrumentation and markers along the flight path.

4.6.1.4 Multi-Direction Approach. A multi-direction approach may be considered in range planning to avoid the detrimental effect on pilot training caused by frequent repetition of the single-direction approach. A minimum of two secondary approaches to the target is desirable, each measuring 1 x 20 mi (1.6 km x 32.18 km). See Facility Plate No. 179-10, Sheet 17, for flight path profile for primary and secondary approach. The two approaches shall be from directions as widely divergent as local conditions permit and shall be oriented to prevent training aircraft from passing over the control tower or spotting towers. Flights over the secondary lanes are not recorded except for the point of bomb impact; however, initial point markers are required at specified locations on the approach lanes. For one type of bull's-eye lighting for target acquisition, refer to Appendix A, Figure A-12.

4.6.2 Targets. Provide a clear area having a minimum radius of 1,500 ft (457.2 m), with the aiming point as its center.

4.6.2.1 Aiming-Point Elevation. The aiming point shall have an elevation sufficient to provide a line of sight to it from an aircraft 50,000 ft (15,240 m) away, approaching at an altitude of 100 ft (30.48 m) above the extant terrain.

4.6.2.2 Aiming-Point Construction. A typical aiming point in flat, open

MIL-HDBK-1027/3A

country should consist of three walls, each 30 ft high by 60 ft long (9.1 m by 18.3 m), forming an equilateral triangle. See Facility Plate No. 179-10, Sheet 18, for vertically-developed target. It should be of frame construction, painted international orange, and oriented so that the primary run-in line forms the perpendicular bisector of one leg of the triangle.

4.6.3 Initial Points. Initial points of aim shall be either fixed or mobile, depending on terrain conditions and local requirements, and shall be elevated above any vegetation or obstruction so as to be clearly visible to pilots of approaching aircraft.

4.6.3.1 Spacing. Initial points shall be placed on each run-in line at 10,000, 15,000, 20,000, 30,000, 40,000, and 50,000 ft (3,048, 4,572, 6,096, 9,144, 1,2192 and 15,240 m) from the target. The points on the primary run-in line shall be radar reflective. All others shall be nonreflective.

4.6.3.2 Details. Details of typical initial points shall be the same as for the High-altitude Level-bombing Range. (See Facility Plate No. 179-10, Figure 4.)

4.6.4 Distance Markers. The primary aircraft approach lane is normally marked, in the last 10 mi (16.09 km) to the target, every 5,000 ft (1,524 m) with 8 x 12 ft (2.44 x 3.66 m) markers. The numeral indicating thousands of feet is 7 ft (2.13 m) high. (See Facility Plate No. 179-10, Sheet 19.)

4.6.5 Control Tower. The loft foot bombing range control tower shall be located approximately 20,000 ft (6,096 m) from the primary run-in line on a line perpendicular thereto and a maximum of 12,000 ft (3,657.6 m) ahead of the target. The tower floor shall be approximately 70 ft (21.34 m) above the ground.

4.6.6 Spotting Towers. Three spotting towers shall be located at 120 intervals on a circle 6,000 ft (1,828.8 m) in radius, having the target as its center and the spotting tower furthest from the control tower being on a line perpendicular to the primary run-in line at the center of the target.

4.6.7 Equipment. Provide the loft-bombing range with electronic scoring equipment.

4.7 Aerial Mining Range. An aerial mining target range is used for training proficiency in the release of mines from aircraft. A water danger zone, as shown in Facility Plate No. 179-10, Sheet 20, is assigned for this purpose and only training shapes are used. Fleet operations using aerial mines during maneuvers have special areas designated by the Fleet Commander for a temporary period. The planning information contained herein pertains to training facilities associated with fleet support air stations. The water depth and bottom conditions that apply to fleet operations are not applicable to a normal aerial mining range training facility.

4.7.1 Site. The airspace-restricted area shall measure a minimum of 3 x 8 mi (4.82 x 12.87 km) and shall be coincidental with the surface-impact area on the water. The length should be parallel to the coastline for maximum visibility from the control tower and spotting towers.

4.7.2 Targets. Normally, the target area should be located along an irregular coastline having readily identifiable landmarks. Specific pinpoint

MIL-HDBK-1027/3A

targets, if desired, shall be constructed and located according to local range requirements. For typical water target, see Facility Plate No. 179-10, Sheet 21. For typical water target details, refer to Facility Plate No. 179-10, Sheet 22.

4.7.3 Initial Points. Initial points of approach may be prominent landmarks. Radar-reflective initial points may be used according to local range requirements in lieu of, or in addition to, these landmarks (fixed or mobile).

4.7.4 Control Tower. The control tower shall conform to the requirements for the Strafing Range Control Tower (SRCT). Locate the control tower on the shoreline, a minimum of 3,000 ft (924 m) outside the surface danger area and as close as practicable to the midpoint of the length of the area.

4.7.5 Spotting Towers. Locate the spotting towers on the shoreline a minimum of 3,000 ft (914 m) outside the surface danger area and as close as practical to opposite ends of the longer dimension of the area. The spotting towers shall meet the same requirements as the strafing range control tower regarding elevation, visibility, and weather protection.

4.7.6 Equipment. The equipment required for the control tower and spotting towers shall be the same as that specified for the High-altitude Level-bombing Range (refer to para 4.4).

4.7.7 Small Boat Dock. If the range is located in a remote area, a small boat dock may be required for one or more 45 ft (13.72 m) picket boats. Refer to MIL-HDBK-1025/6, General Criteria for Waterfront Construction.

4.8 Close Air Support and Combat Training Area. A live ordnance impact area is used for close air support training with live ordnance of various types, including high explosives, air-to-ground guided missiles, napalm bombs, and parachute flares.

4.8.1 Site. The range shall have a restricted area keeping other aircraft out with a minimum radius of 25 nautical mi. A rectangular surface-impact area of 16 x 20 nautical miles shall be located in the center of the restricted area. See Facility Plate No. 179-10, Sheet 23, for layout.

4.8.1.1 Description. Training area will include remotely controlled pop-up, vehicle silhouette targets, and scored fire suppression strafing banners. The actual size pop-up targets should be consumables constructed of locally procured materials reproduced from centrally distributed patterns. The targets and pop-up operating mechanism should be mobile for redeployment within six hours. The pop-up mechanism should be buried and only the actuator arm(s) exposed to direct fire, inert practice ordnance (5.56 to 5 in. FFAR/155). Fire suppression/strafing banners should be scored, fixed sites. The banners should allow scoring over a 150 degree arc. This engagement latitude is necessary to properly score attack helicopter running fire (aircraft flight path different from turret firing direction), attack aircraft strafing engagements as well as suppressing fire from ground convoys and helicopter door gunners.

4.8.1.2 Surface Designation. The corners or extremities of the surface danger area shall be marked by permanent radar-reflective markers to facilitate positive identification from the air.

MIL-HDBK-1027/3A

4.8.1.3 Fire Protection. In an area which is wooded or covered with other flammable vegetation, firebreaks shall be provided as required by the local fire protection engineer.

4.8.2 Targets. The impact area should encompass various types of terrain to provide more realistic training. Individual targets shall be determined by the local commands and may simulate the following: convoys, gun emplacements, mortar pits, airstrips, tanks, troops, and parked aircraft. Typical close air support targets are shown in Facility Plate No. 179-10, Sheet 24. For details of various targets, see Facility Plate No. 179-10, Sheet 25.

4.8.3 Control Tower. Provide one control tower for each target site. Control towers shall conform to the requirements for Strafing Range Control Towers with modifications as follow in paras 4.8.3.1 through 4.8.3.4.

4.8.3.1 Water and Sanitary Systems. If a range is operated on a full time basis, a water supply system and sanitary facilities shall be provided. All water supply and pollution control system development should consider criteria contained in NAVFAC DM-5.7, Water Supply Systems, and DM-5.8, Pollution Control Systems.

4.8.3.2 Security. Provide for locking and securing the tower if it is to be vacated for prolonged periods of time. In remote areas, provide fencing around tower to reduce tower access and control vandalism.

4.8.3.3 Safety. Locate towers to provide maximum safety for operating personnel.

4.8.3.4 Visibility. Locate towers to provide maximum visual coverage of range areas consistent with local topography and vegetation.

4.8.4 Spotting Towers. Provide two spotting towers for each designated target site. The spotting towers shall meet the same requirements as those specified for control towers.

4.8.5 Firehouse. In an impact area which is wooded or covered with other flammable vegetation, provide one building to house firefighting equipment. It shall meet the same requirements as those specified for control towers concerning weather protection, personnel safety, water supply, sanitary facilities, and locking and securing.

4.8.6 Equipment. For control towers and spotting towers, provide the same equipment as specified for High-altitude Level-bombing Ranges (refer to para 4.4). If the firehouse is not immediately adjacent to the control tower, it shall be provided with telephone or radio equipment for communication with the tower. Provide the type and number of pieces of firefighting equipment in accordance with local range requirements.

4.9 Guided Missile Range. The air-to-ground guided missile target range is used for training in controlled air-to-ground missiles. Refer to NAVFAC P-80 for airspace and impact area requirements and to the close air support and combat training area for target, towers, and equipment requirements. See Facility Plate No. 179-10, Sheet 26, for typical restricted area.

4.10 Air-to-Air Weapons Range. An air-to-air gunnery and rocket firing

MIL-HDBK-1027/3A

range is a rectangular area, preferably over water. Ground personnel and structures are not required. Refer to NAVFAC P-80 for surface impact areas. Facilities will be designed if requirements include Tactical Aircrew Combat Training System (TACTS). The TACTS provides real time monitoring and postexercise evaluation of aircrew performance in air combat maneuvering, simulated air-to-air and air-to-ground missile firings, no-drop bomb, and aerial minelaying scoring. Banner drop areas and cable cutter are areas where towed aerial targets may be released and land to be retrieved and used again. Criteria for locations of area must be requested from user.

4.11 Radar Bomb Scoring (RBS) Facility

4.11.1 Layout. The mobile RBS equipment includes the operation trailer, acquisition radar, tracking radar, maintenance and spare parts trailer, power trailer, and trucks. Fixed RBS systems utilizing permanent structures may be situated at aircraft ranges or at remote sites. A permanent power supply of 115/208 V, 3-phase, 4-wire, 60 Hz, 100 kW with capability of converting up to 35 kW from 60 to 400 Hz eliminates the power trailer requirements. See Facility Plate No. 179-70, Sheet 1, for Radar Bomb Scoring (RBS) Facility and Facility Plate No. 179-70, Sheet 2, for RBS typical layout. Designer should request from the user the latest information on required equipment when designing a facility.

4.11.2 Function. The RBS facility provides for the evaluation of weapons delivery under realistic conditions. RBS is a technique for predicting the theoretical impact point of a bomb with respect to a target by means of a ground-based radar and computer system. The system tracks the aircraft. The system computes the theoretical trajectory and permanently records pertinent data including the miss distance and deflection of the predicted impact or burst from the position and velocity of the aircraft at the release time of a radio signal to the ground. Because it is not necessary to release an actual bomb, simulated attacks against realistic targets (such as cities, bridges, and factories) can be scored. The mobile RBS equipment allows for a variety of targets comparable to those which would be imposed under actual combat conditions.

MIL-HDBK-1027/3A

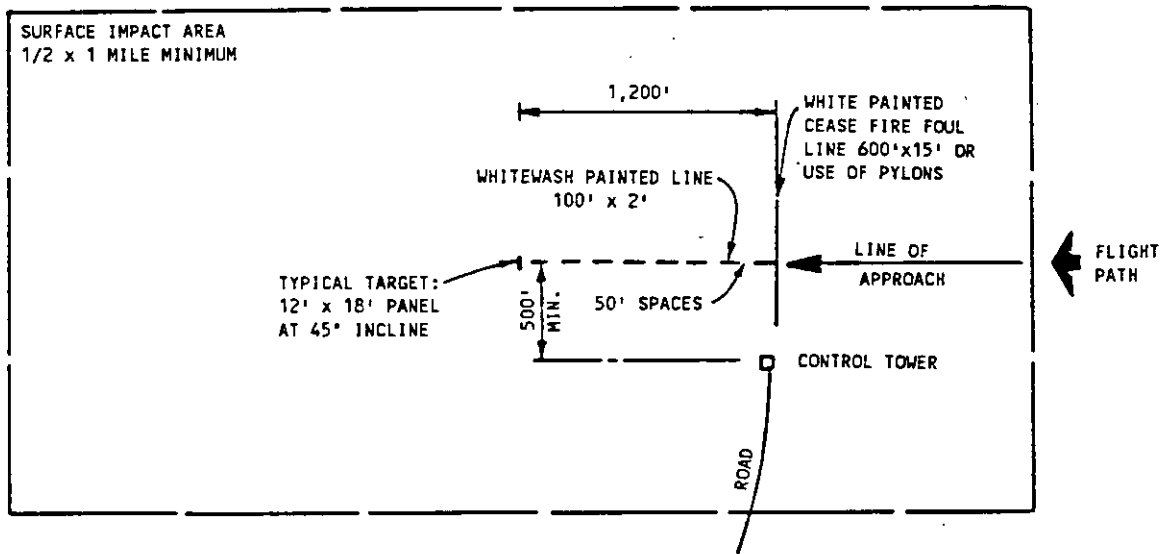

TITLE :	DATE	FACILITY PLATE NO.	SHEET
STRAFING RANGE	OCT 87	179- 10	1

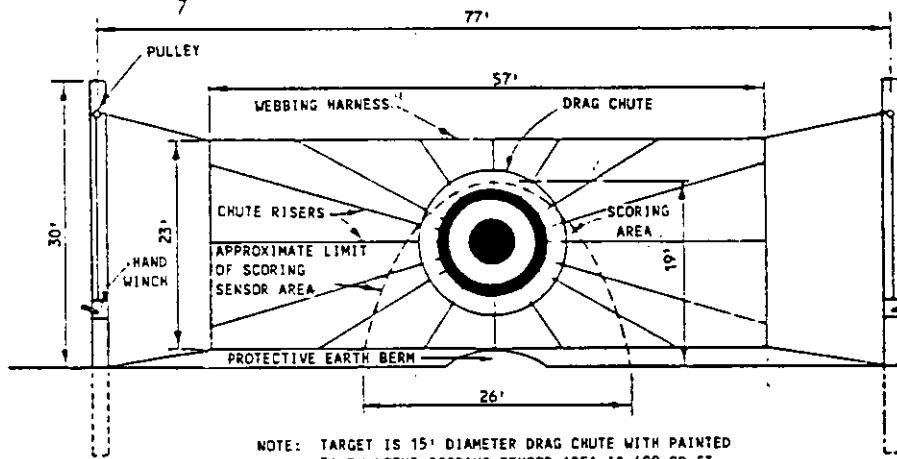
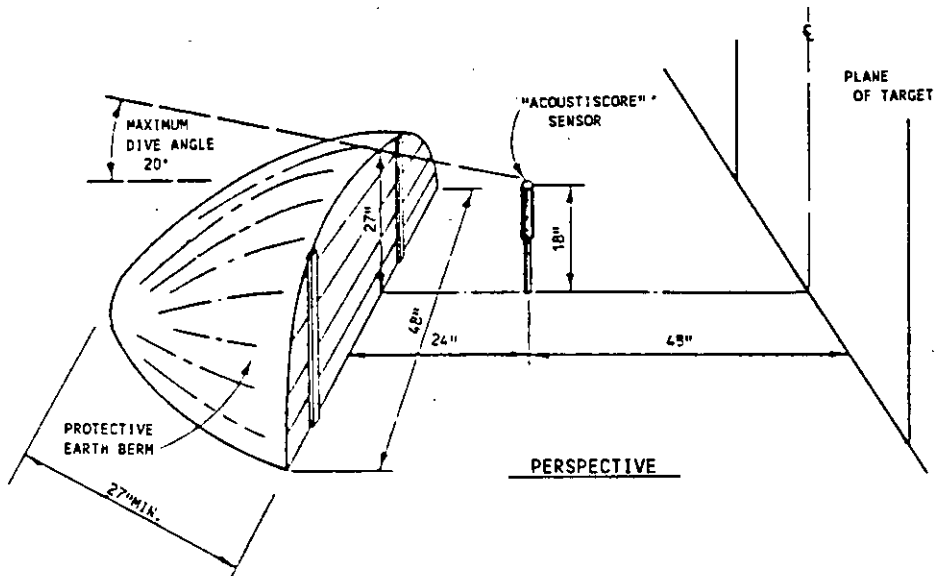

NOTE: TARGET IS 15' DIAMETER DRAG CHUTE WITH PAINTED 5' BULLSEYE SCORING SENSOR AREA IS 400 SQ FT

TITLE :	DATE	FACILITY PLATE NO.	SHEET
ACOUSTISCORE STRAFING TARGET	OCT 87	179- 10	2

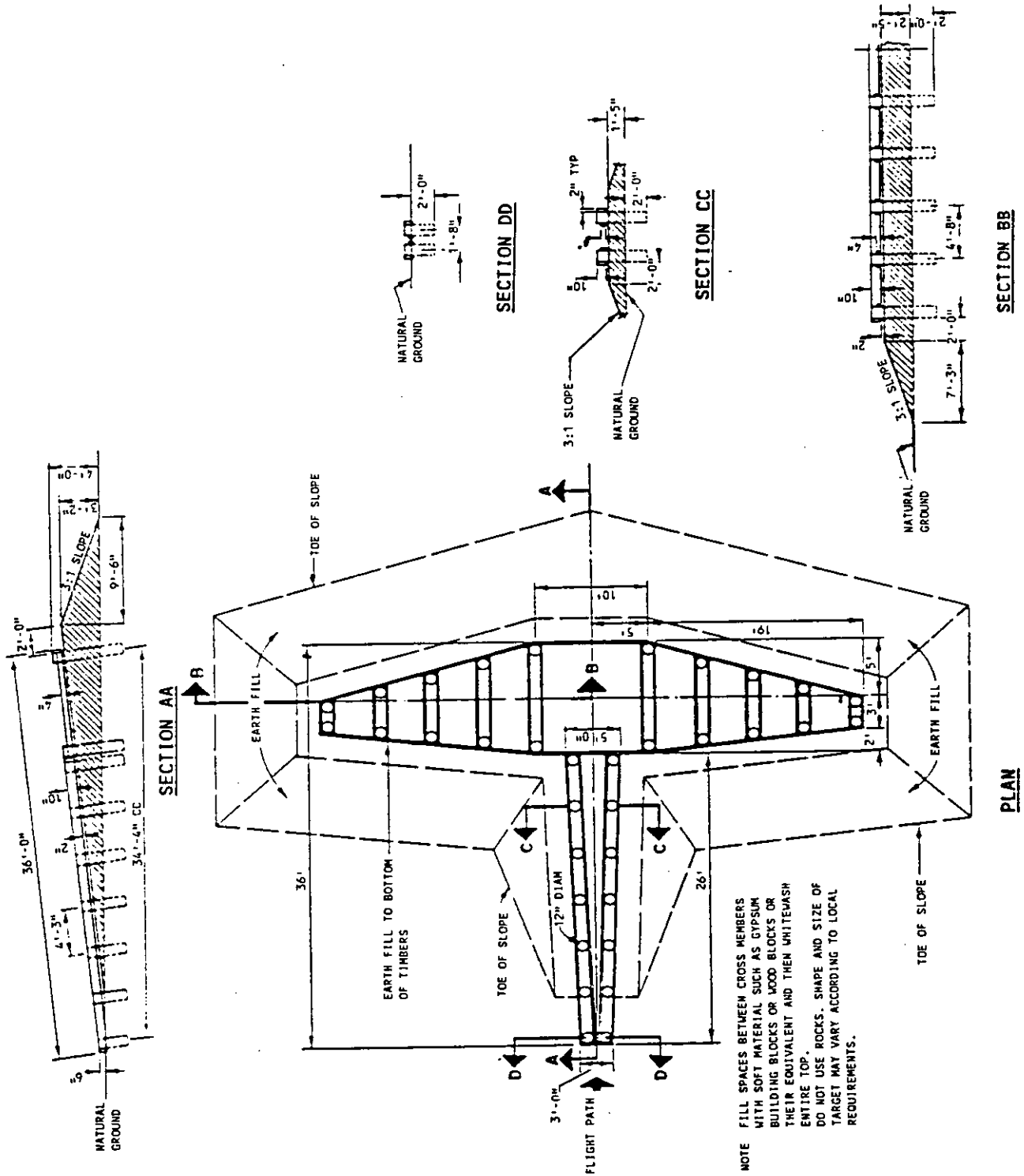

TITLE: TYPICAL AIRCRAFT STRAFING TARGET

DATE OCT 87

FACILITY PLATE NO. 179-10

SHEET 3

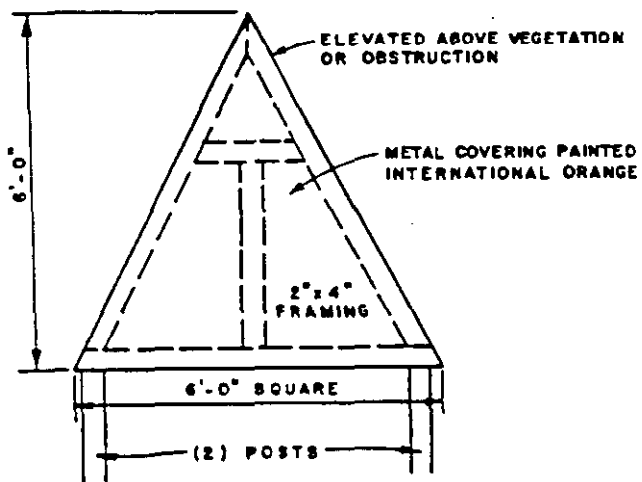

TITLE: FIXED INITIAL POINT MARKER	DATE OCT 87	FACILITY PLATE NO. 179- 10	SHEET 4
--------------------------------------	----------------	-------------------------------	------------

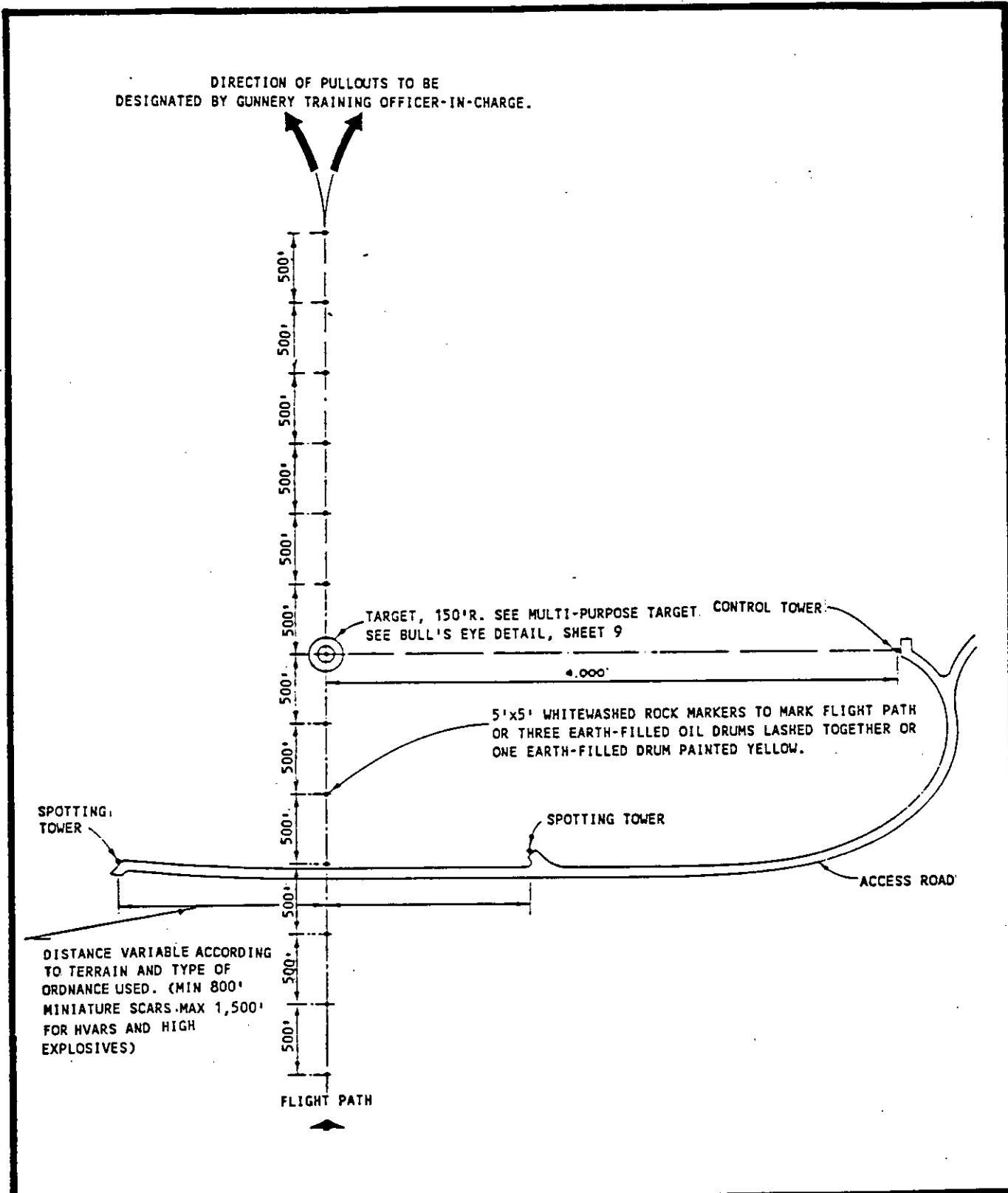

TITLE :	DATE	FACILITY PLATE NO.	SHEET
ROCKET/BOMBING RANGE	OCT 87	179- 10	5

MIL-HDBK-1027/3A

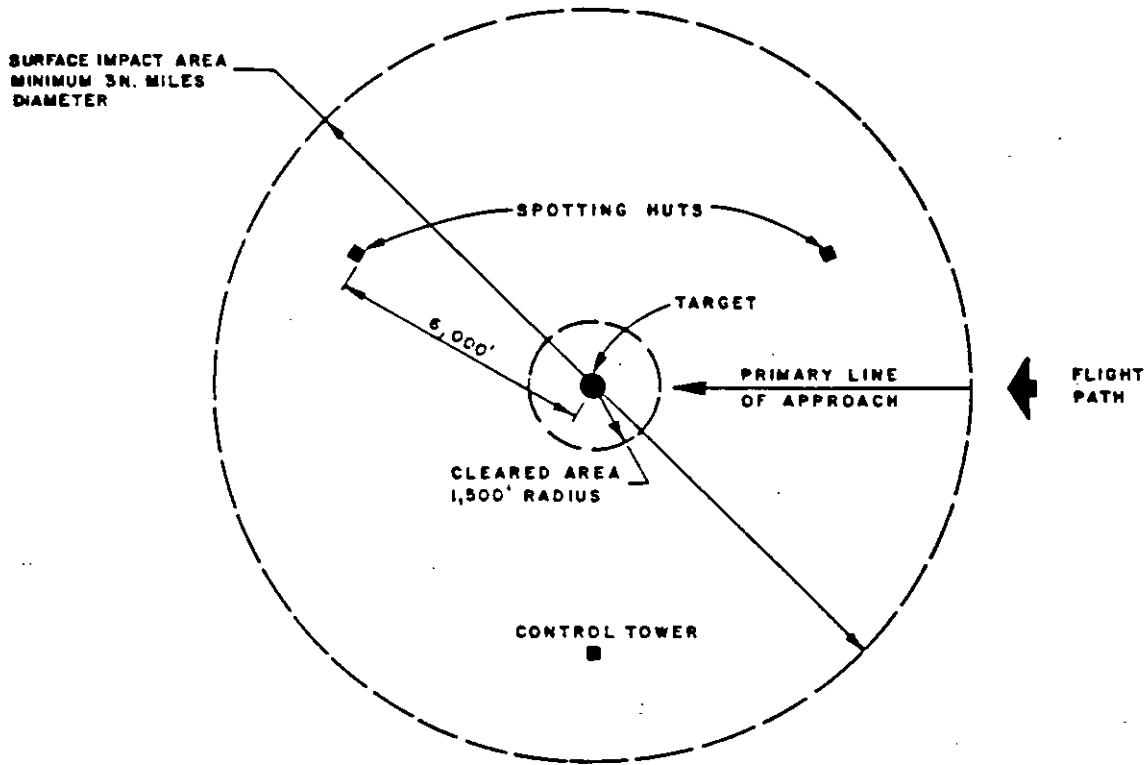

TITLE :	DATE	FACILITY PLATE NO.	SHEET
MULTI-PURPOSE RANGE	OCT 87	179- 10	6

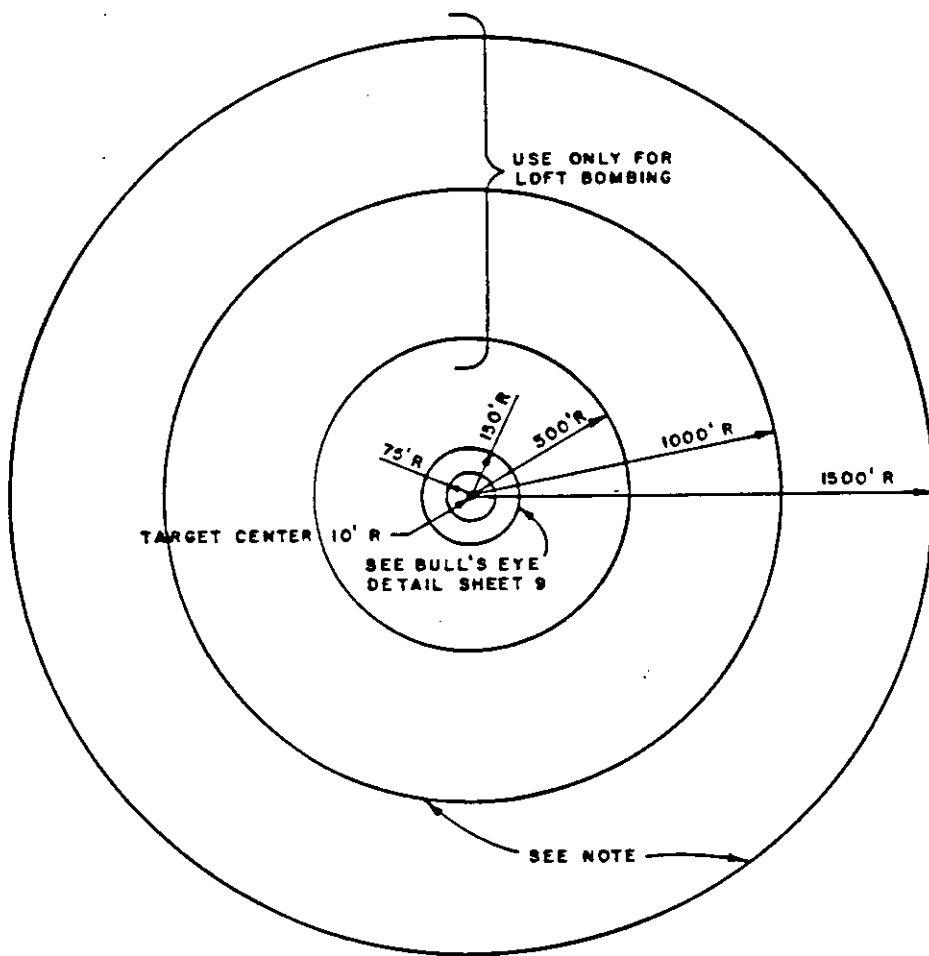

NOTE:
TARGET OUTLINES ON THE GROUND
MAY BE: RAISED MOUNDS OF EARTH;
GYPSUM BLOCKS; SOFT SANDSTONE
SLABS, WHITEWASHED; WHITEWASHED
ROCK MARKERS (EXCEPT BULL'S EYE);
PAINTED OIL DRUMS OR TIRES.

TITLE: MULTI-PURPOSE TARGET	DATE OCT 87	FACILITY PLATE NO. 179-10	SHEET 7
--------------------------------	----------------	------------------------------	------------

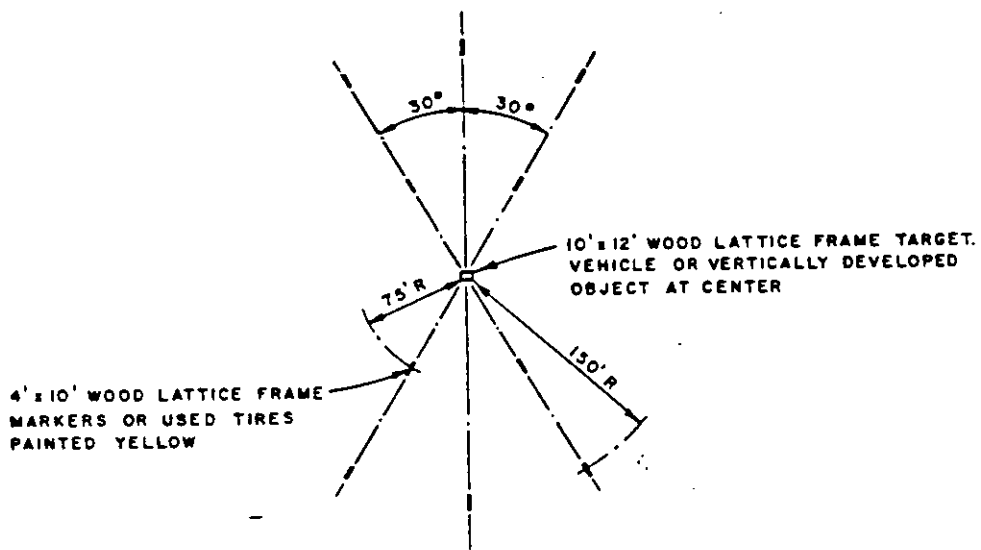

TITLE: ALTERNATE MULTI-PURPOSE TARGET LAYOUT	DATE OCT 87	FACILITY PLATE NO. 179-10	SHEET 8
--	----------------	------------------------------	------------

CONSTRUCT BANDS USING GYPSUM BLOCKS 2-1/2" x 12" x 30" WITH 30" SPACES BETWEEN BLOCKS (SEE DETAIL "C") OR DRY GYPSUM ON RAISED EARTH BANDS APPROXIMATELY 12" HIGH (TYPICAL)

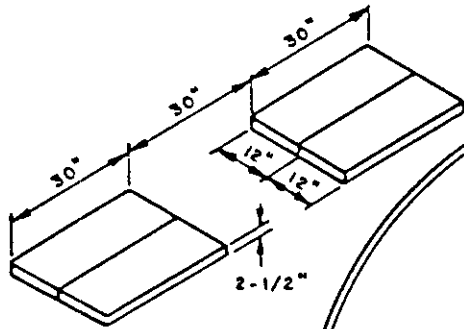

DETAIL C

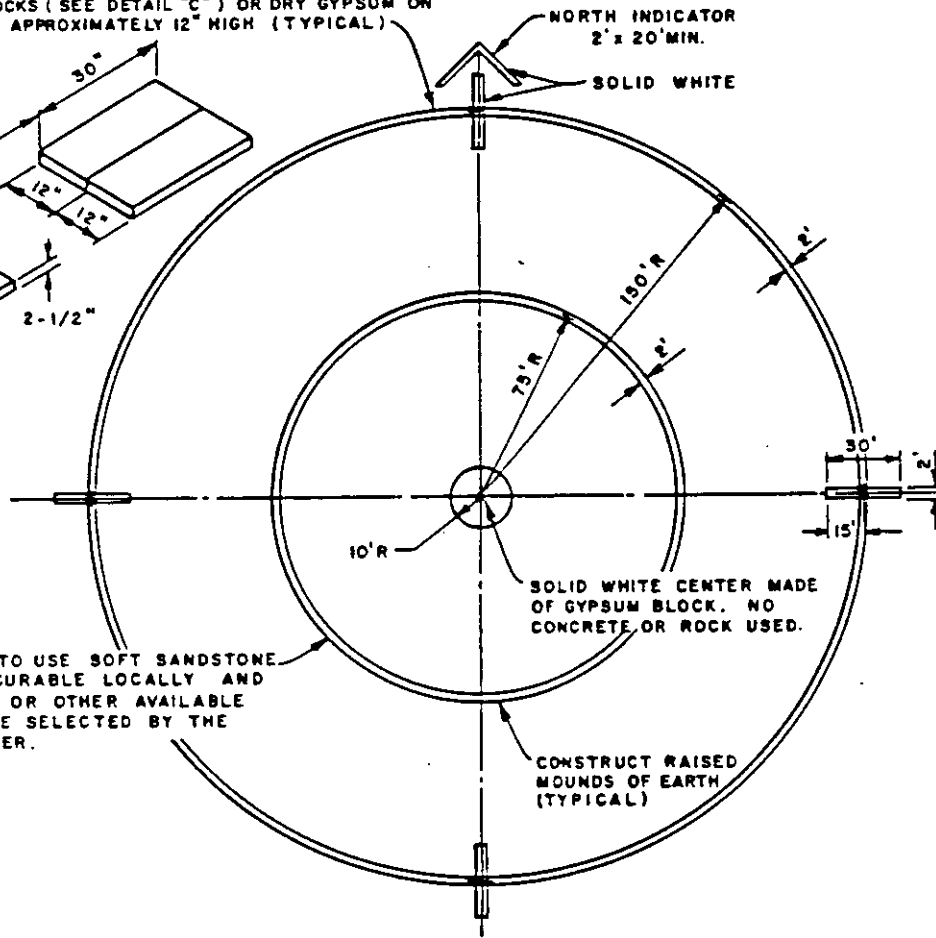

PERMISSIBLE TO USE SOFT SANDSTONE SLABS, IF PROCURABLE LOCALLY AND WHITEWASHED, OR OTHER AVAILABLE MATERIAL TO BE SELECTED BY THE GUNNERY OFFICER.

CONSTRUCT RAISED MOUNDS OF EARTH (TYPICAL)

SEE NOTE SHEET 7

TITLE :	DATE	FACILITY PLATE NO.	SHEET
BULL'S EYE DETAIL	OCT 87	179- 10	9

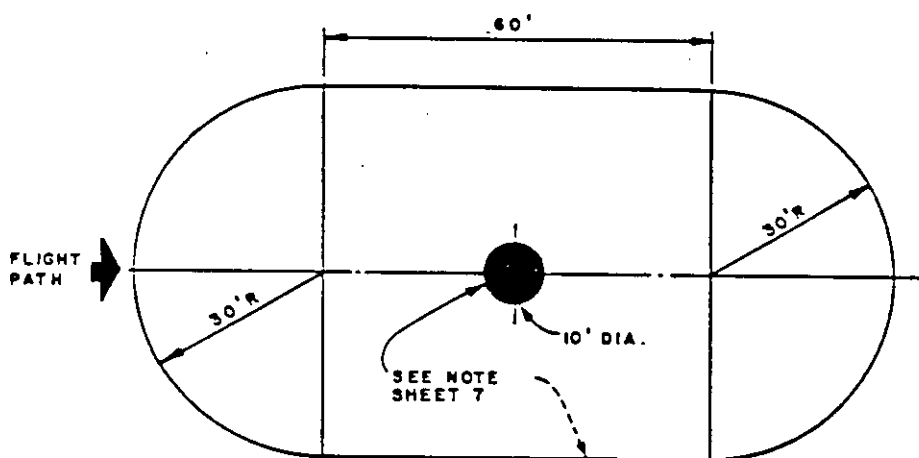

TITLE :	DATE	FACILITY PLATE NO.	SHEET
ALTERNATE ROCKET TARGET	OCT 87	179-10	10

DIVE BOMBING
MINIMUM ALTITUDE RELEASE

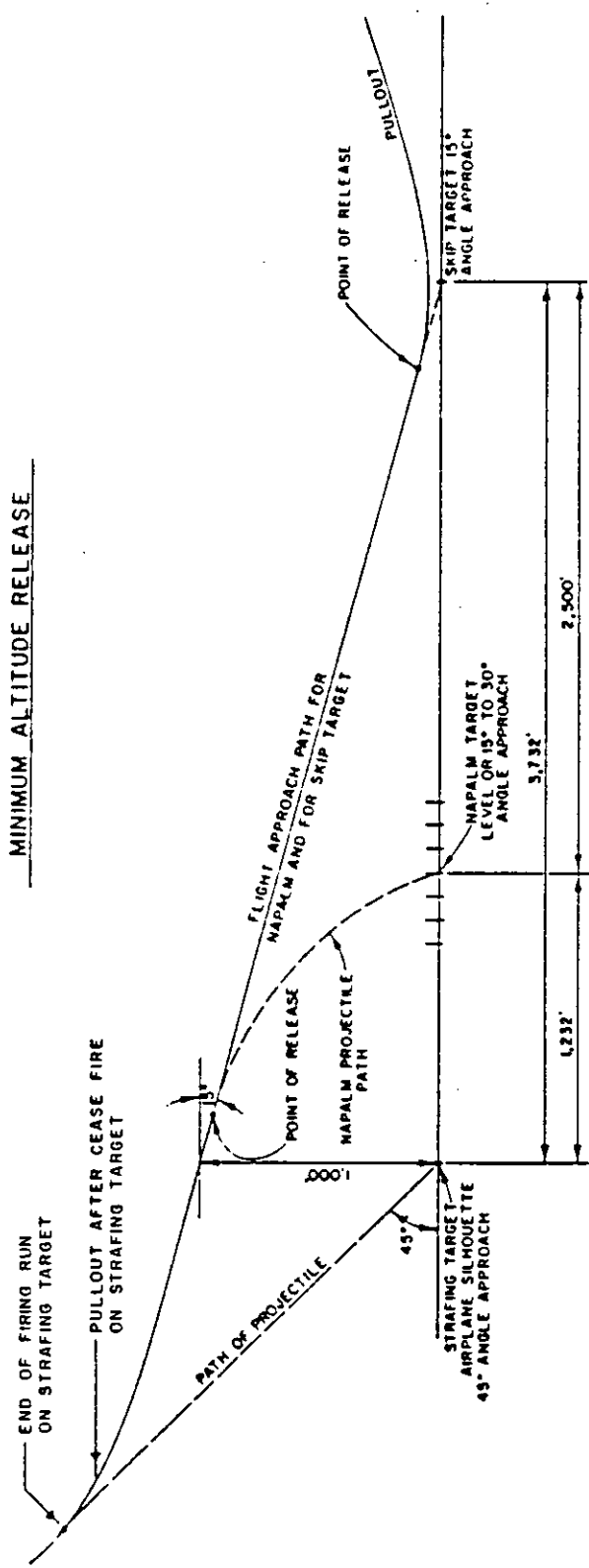

<p>TITLE: TYPICAL MULTI-TARGET FLIGHT PATH</p>	<p>DATE OCT 87</p>	<p>FACILITY PLATE NO. 179 - 10</p>	<p>SHEET 11</p>
--	------------------------	--	---------------------

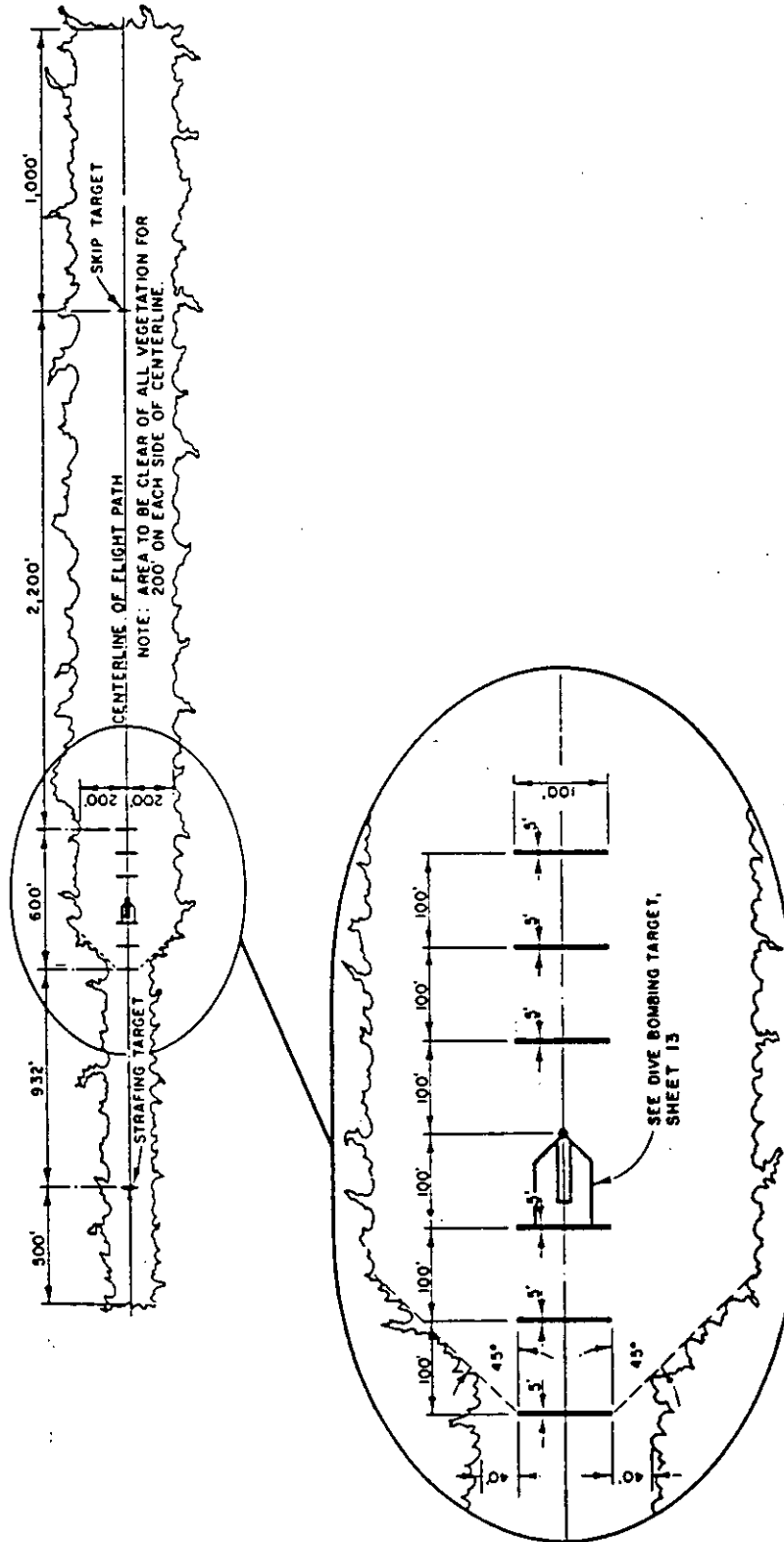

<p>TITLE: DIVE BOMBING RANGE PLAN</p>	<p>DATE OCT 87</p>	<p>FACILITY PLATE NO. 179- 10</p>	<p>SHEET 12</p>
--	-------------------------------	--	----------------------------

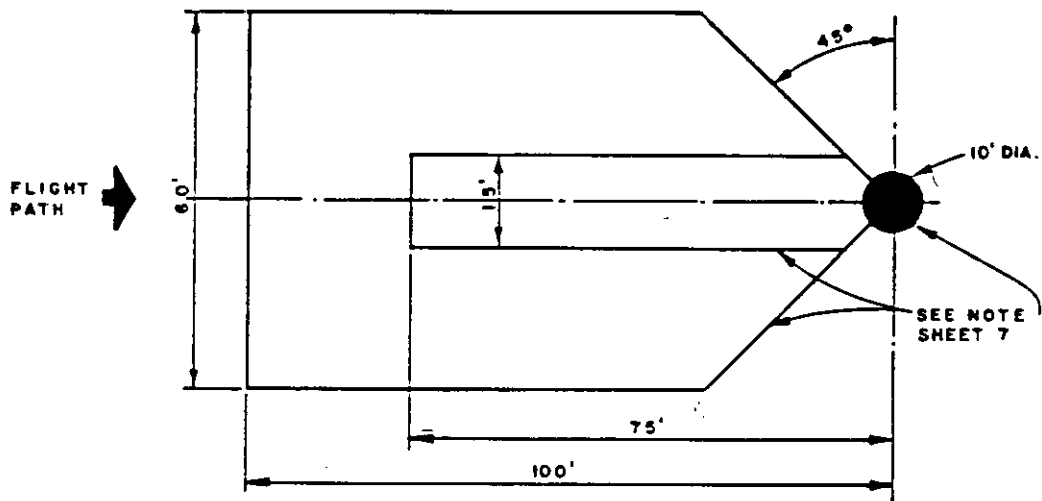

TITLE: DIVE BOMBING TARGET MINIMUM ALTITUDE RELEASE	DATE OCT 87	FACILITY PLATE NO. 179- 10	SHEET 13
---	----------------	-------------------------------	-------------

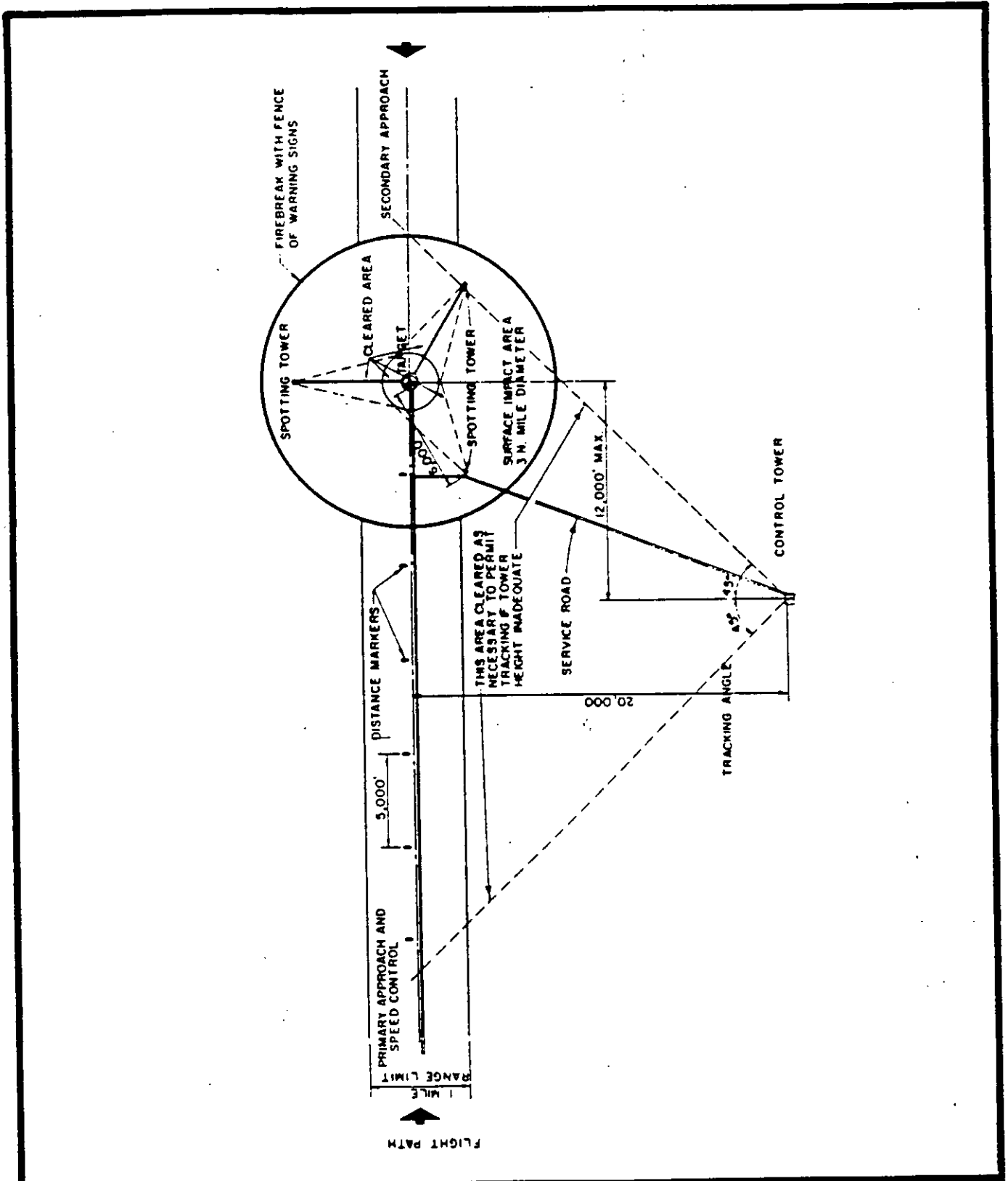

<p>TITLE: LOFT BOMBING RANGE</p>	<p>DATE OCT 87</p>	<p>FACILITY PLATE NO. 179-10</p>	<p>SHEET 14</p>
--------------------------------------	------------------------	--------------------------------------	---------------------

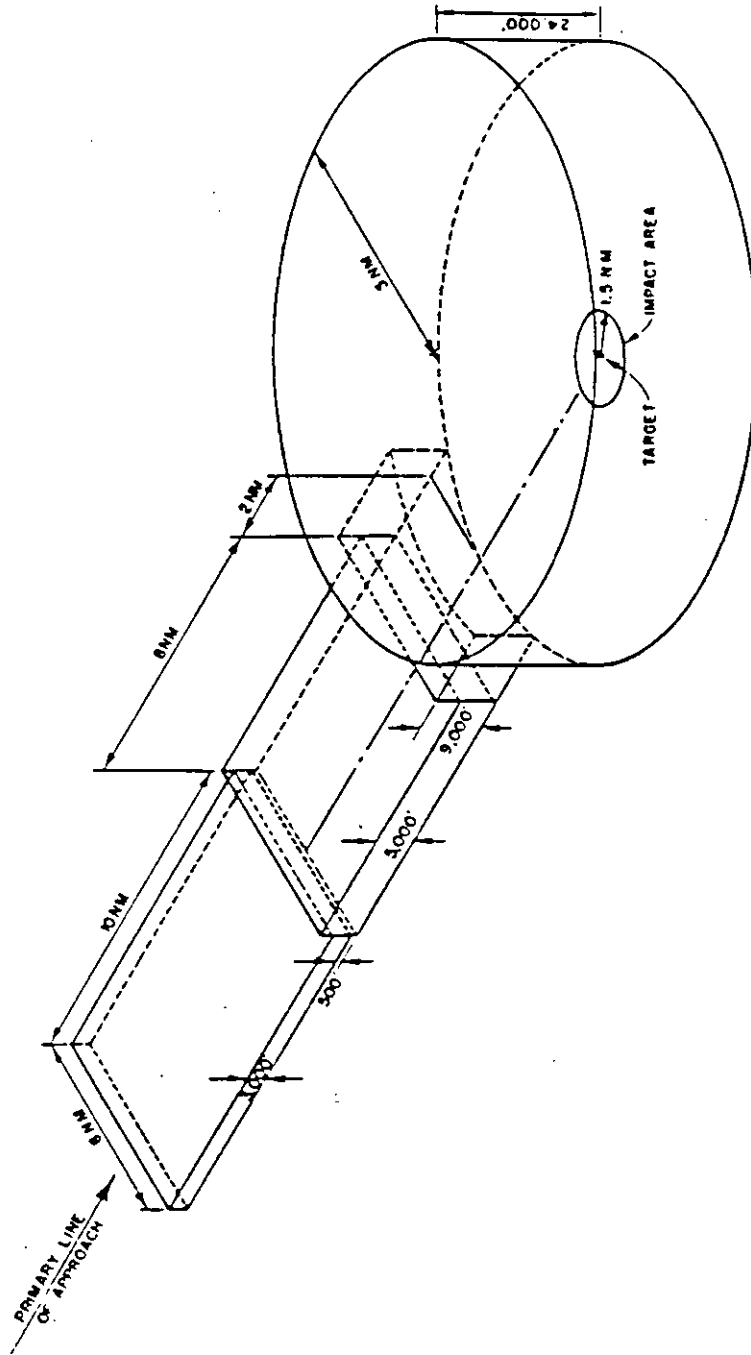

TITLE: LOFT BOMBING TARGET
 RESTRICTED ZONE
 PRIMARY APPROACH

DATE
 OCT 87

FACILITY PLATE NO.
 179-10

SHEET
 15

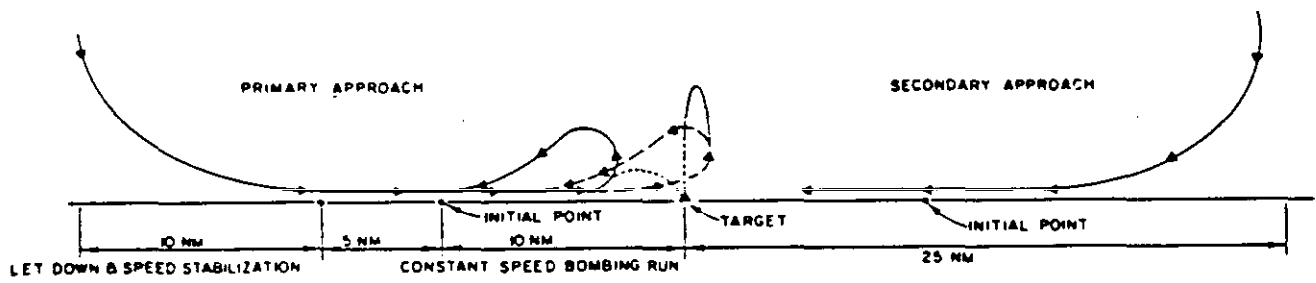

NOTE 1
REFER TO SHEET 17 FOR TARGET AREA DETAIL

TITLE: FLIGHT PATH PROFILE	DATE OCT 87	FACILITY PLATE NO. 179-10	SHEET 16
-------------------------------	----------------	------------------------------	-------------

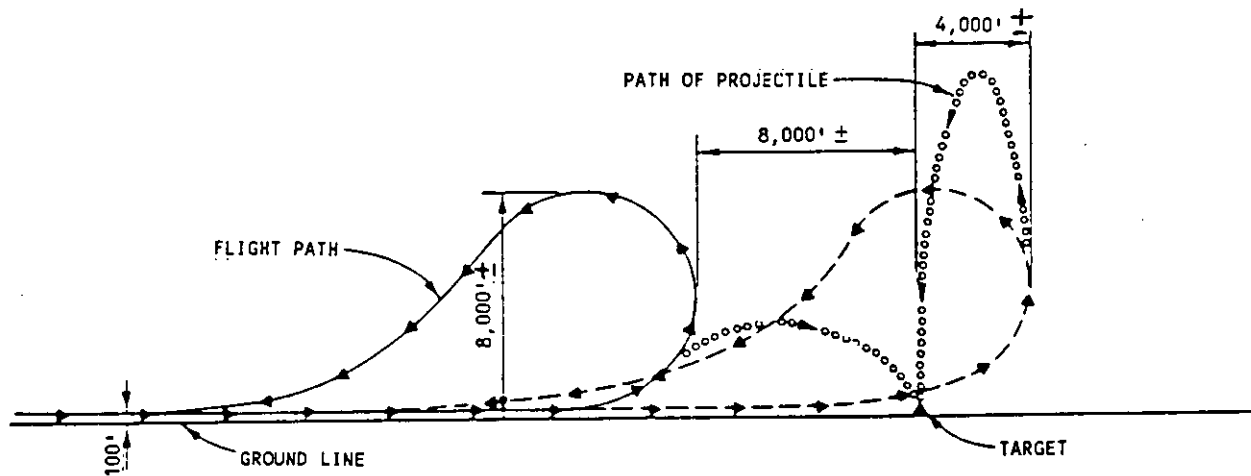

TITLE: FLIGHT PATH PROFILE TARGET AREA DETAIL	DATE OCT 87	FACILITY PLATE NO. 179- 10	SHEET 17
---	----------------	-------------------------------	-------------

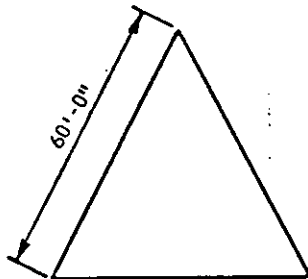

PLAN



ELEVATION

TITLE: TARGET CONFIGURATION FOR VERTICALLY DEVELOPED TARGET FOR HIGH ALTITUDE OR LOFT BOMBING	DATE OCT 87	FACILITY PLATE NO. 179-10	SHEET 18
--	----------------	------------------------------	-------------

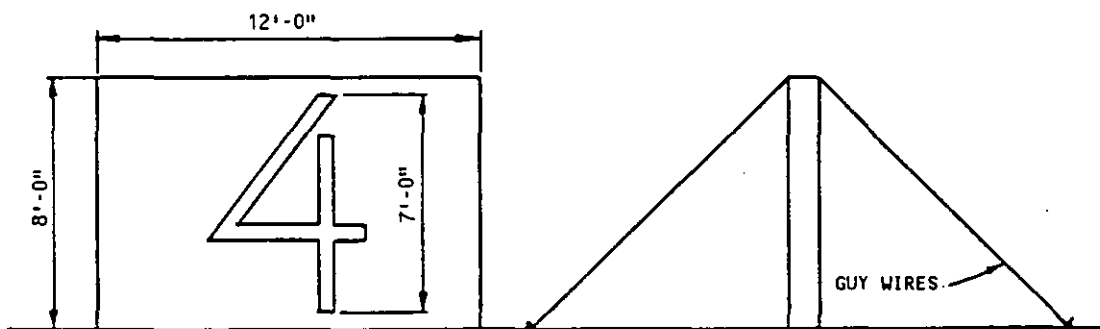

TITLE :	DATE	FACILITY PLATE NO.	SHEET
DISTANCE MARKER	OCT 87	179- 10	19

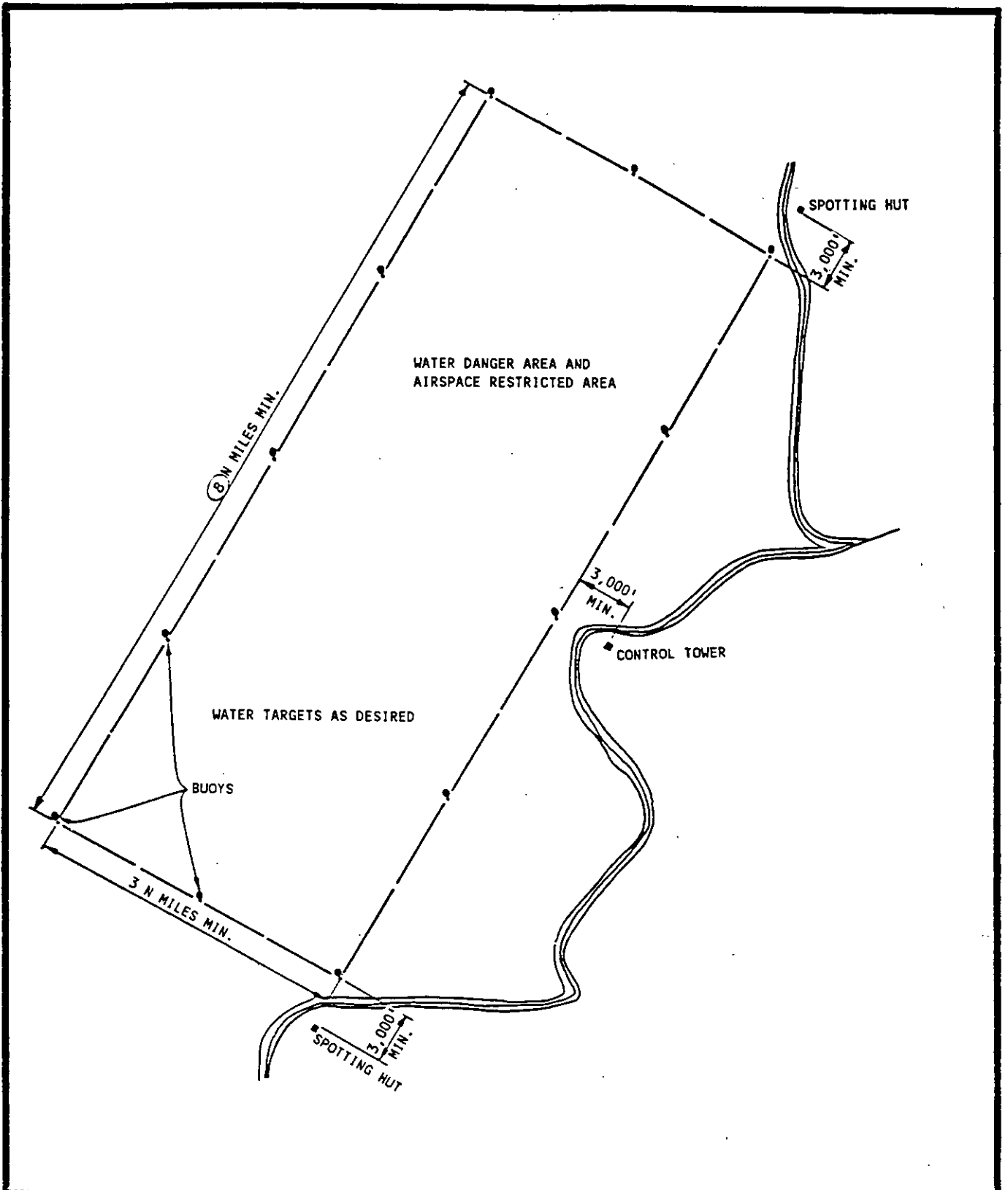

TITLE :	DATE	FACILITY PLATE NO.	SHEET
AERIAL MINING RANGE	OCT 87	179-10.	20

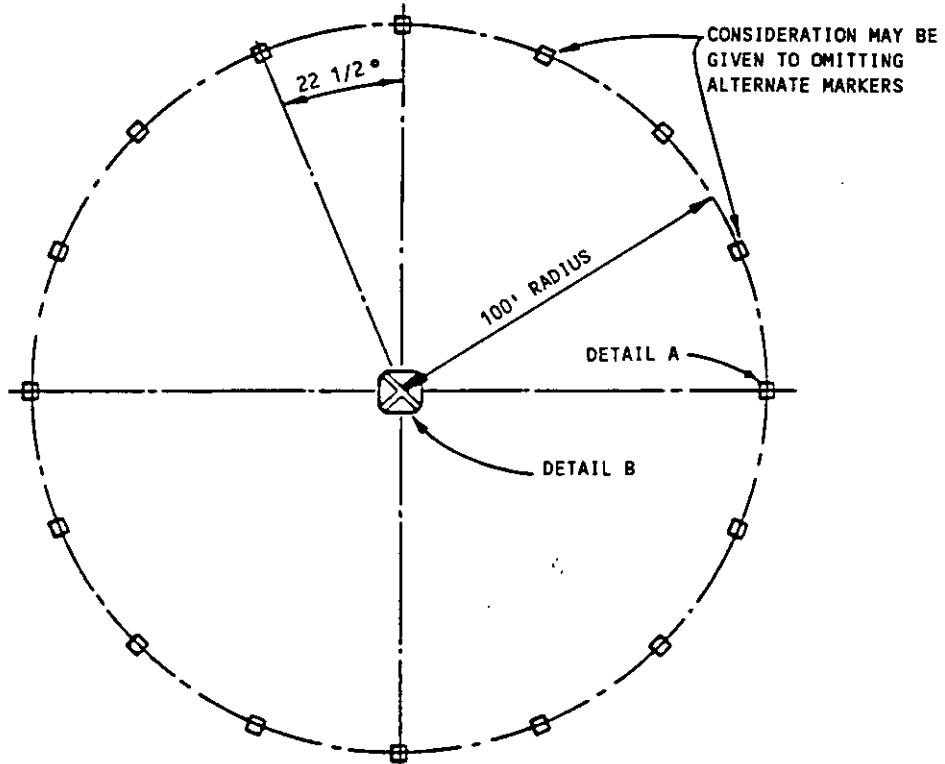

REFER TO SHEET 22

TITLE:	DATE	FACILITY PLATE NO.	SHEET
TYPICAL WATER TARGET	OCT 87	179 - 10	21

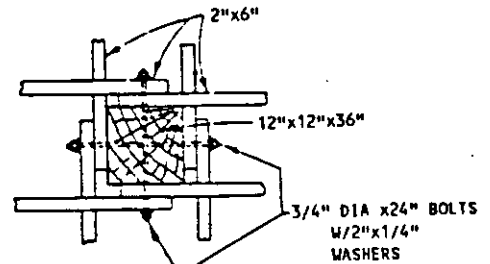

TOP OF PYRAMID

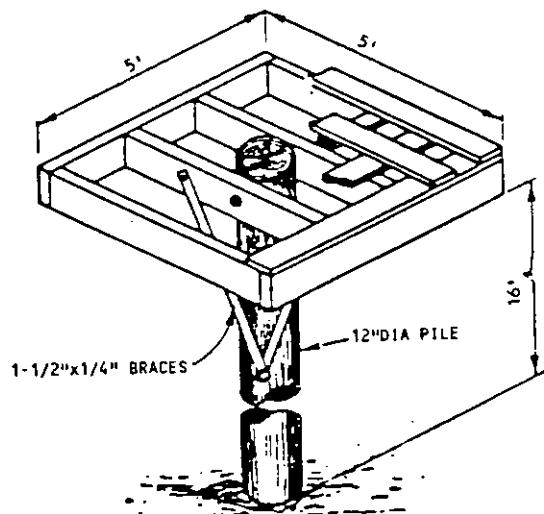

DETAIL A

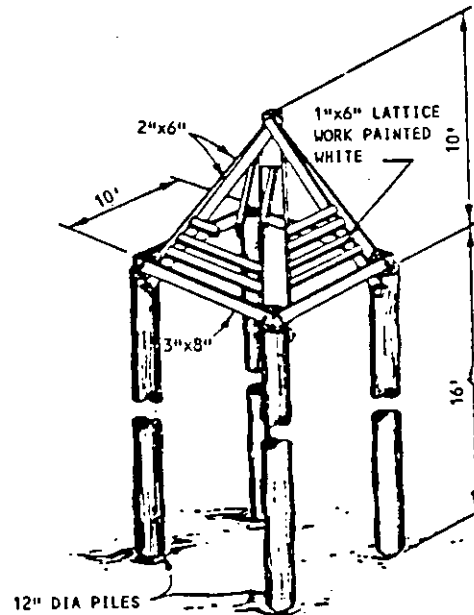

DETAIL B

TITLE :
TYPICAL WATER TARGET DETAILS

DATE
OCT 87

FACILITY PLATE NO.
179-10

SHEET
22

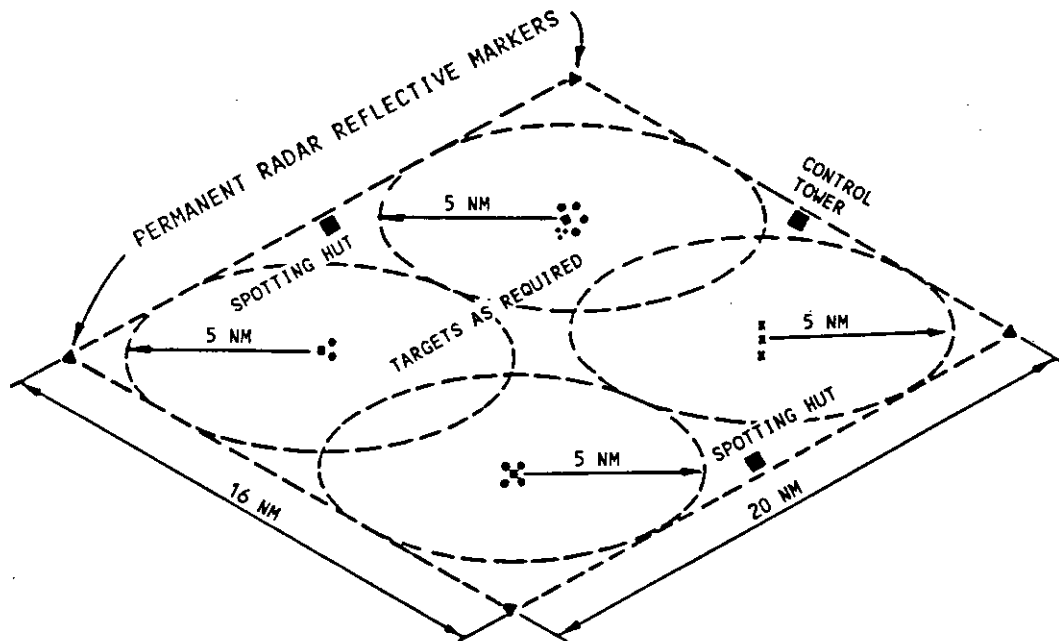

TITLE: CLOSE AIR SUPPORT AND COMBAT TRAINING AREA LIVE ORDNANCE MULTI-TARGET IMPACT AREA	DATE OCT 87	FACILITY PLATE NO. 179- 10	SHEET 23
---	----------------	-------------------------------	-------------

MIL-HDBK-1027/3A

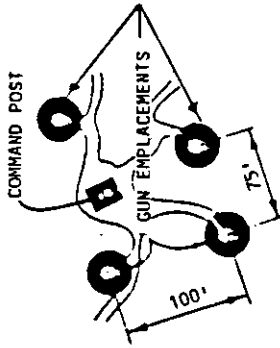

LIGHT AA BATTERY

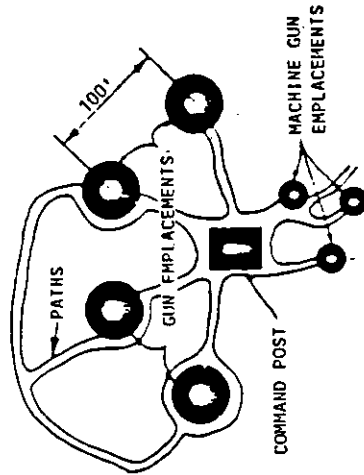

MEDIUM AA BATTERY

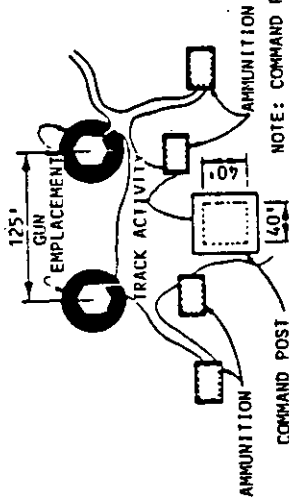

NOTE: COMMAND POST SAME
CONSTRUCTION AS AMMUNITION
STORAGE SPACES.

HEAVY AA BATTERY

<p>TITLE: TYPICAL CLOSE AIR SUPPORT TARGETS</p>	<p>DATE OCT 87</p>	<p>FACILITY PLATE NO. 179- 10</p>	<p>SHEET 24</p>
---	------------------------	---------------------------------------	---------------------

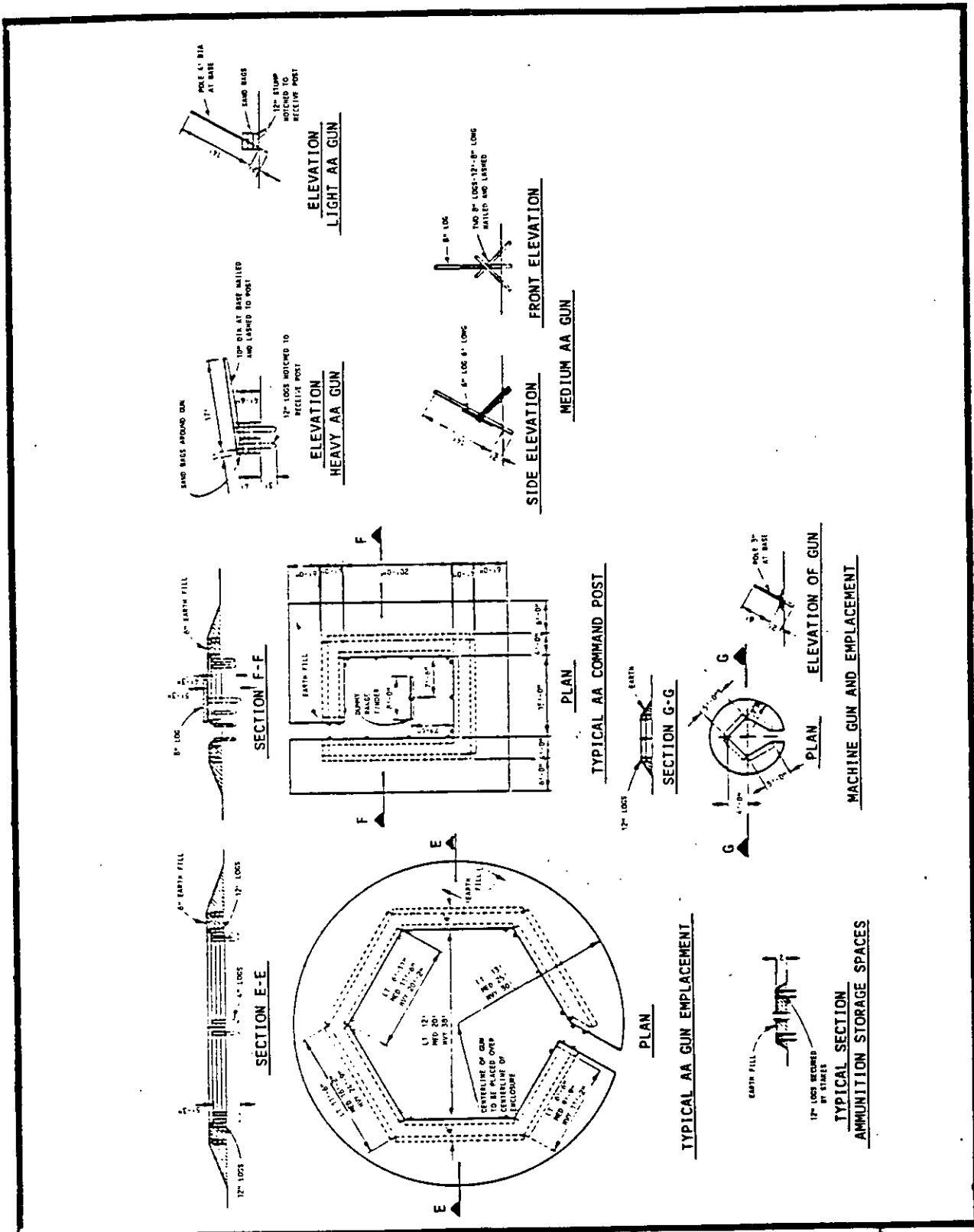

<p>TITLE: CLOSE AIR SUPPORT TARGET DETAILS</p>	<p>DATE OCT 87</p>	<p>FACILITY PLATE NO. 179- 10</p>	<p>SHEET 25</p>
---	---------------------------	--	------------------------

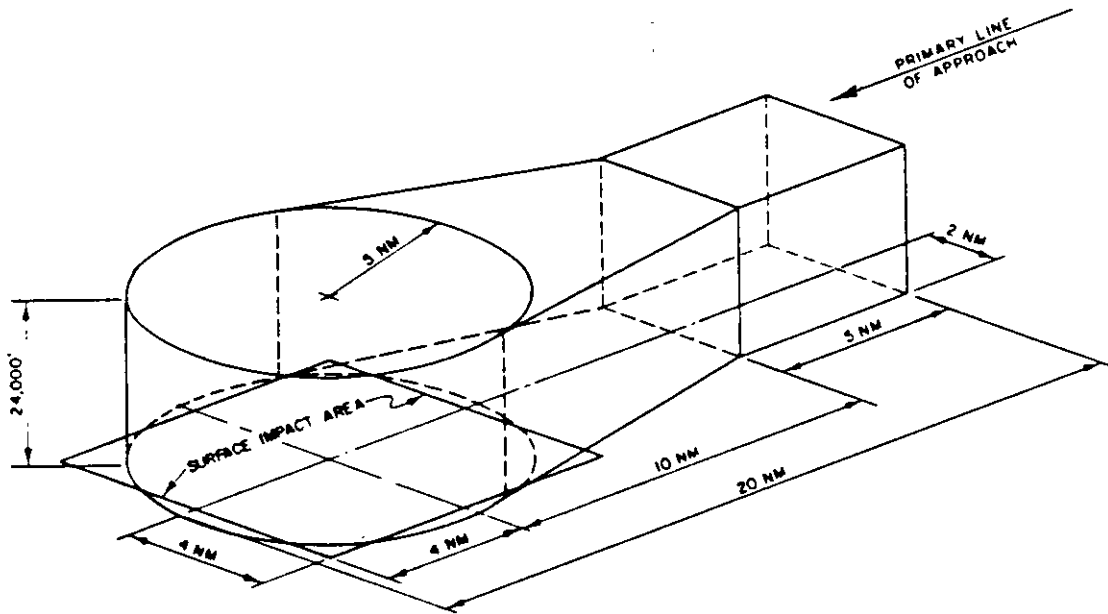

DIMENSIONS ARE BASED ON PERFORMANCE CHARACTERISTICS OF SELECTED MISSILE

TITLE:
TYPICAL AIR-TO-GROUND GUIDED
MISSILE RANGE-RESTRICTED ZONE

DATE
OCT 87

FACILITY PLATE NO.
179-10

SHEET
26

MIL-HDBK-1027/3A

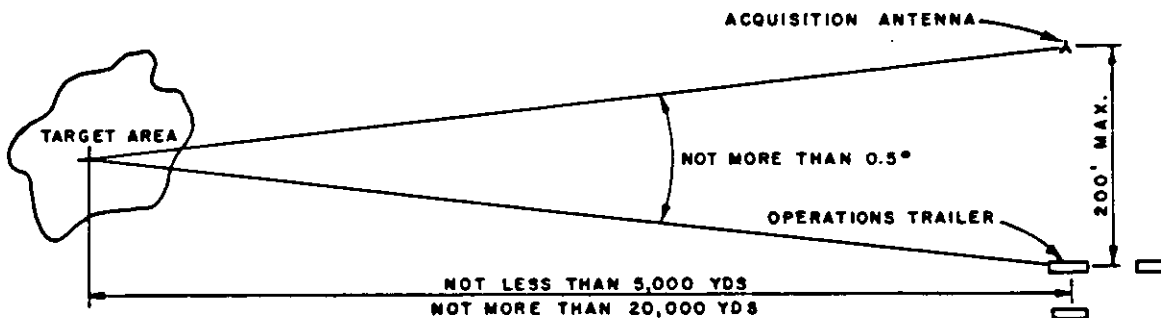

1. TYPICAL SITING OF MOBILE RADAR BOMB SCORING CENTRAL (AN/MSQ-44) REQUIRES THAT THE ACQUISITION ANTENNA (6' HIGH) BE NO HIGHER THAN THE TRACKING ANTENNA WHICH IS MOUNTED ON TOP OF THE OPERATIONS TRAILER (OVERALL HEIGHT 28') THAT THE ANTENNAS ARE MUTUALLY VISIBLE, AND THAT THE ACQUISITION ANTENNA HAVE AN UNOBSTRUCTED VIEW OF THE SECTOR IN WHICH THE MOST ACTIVITY IS EXPECTED.
2. THE POWER TRAILER PAD IS NOT REQUIRED WHERE COMMERCIAL POWER IS AVAILABLE AT THE OPERATIONS TRAILER SITE. PROVIDE FOUNDATION ADJACENT TO OPERATIONS TRAILER FOR 60 Hz / 400 Hz CONVERTER.
3. POWER REQUIREMENTS:
60 Hz, 120/208 V, 3 ϕ , 4W, 100KW, 0.8pt, TOTAL
400 Hz, 120/208 V, 3 ϕ , 4W, 35KW.
4. DESIGN PADS IN ACCORDANCE WITH NAVFAC DM-5.04
TRAILER WEIGHTS:

OPERATIONS	24,500 POUNDS
MAINTENANCE	12,300 POUNDS
POWER	16,700 POUNDS
5. REFER TO NAVAIR HANDBOOK 16-30 MSQ44-2 FOR CABLE INTERCONNECTIONS; PROVIDE CABLE TRENCH OR CONDUITS AT ROAD CROSSINGS.

TITLE :

**RADAR BOMB
SCORING FACILITY SITING**

DATE

OCT 87

FACILITY PLATE NO.

179-70

SHEET

1

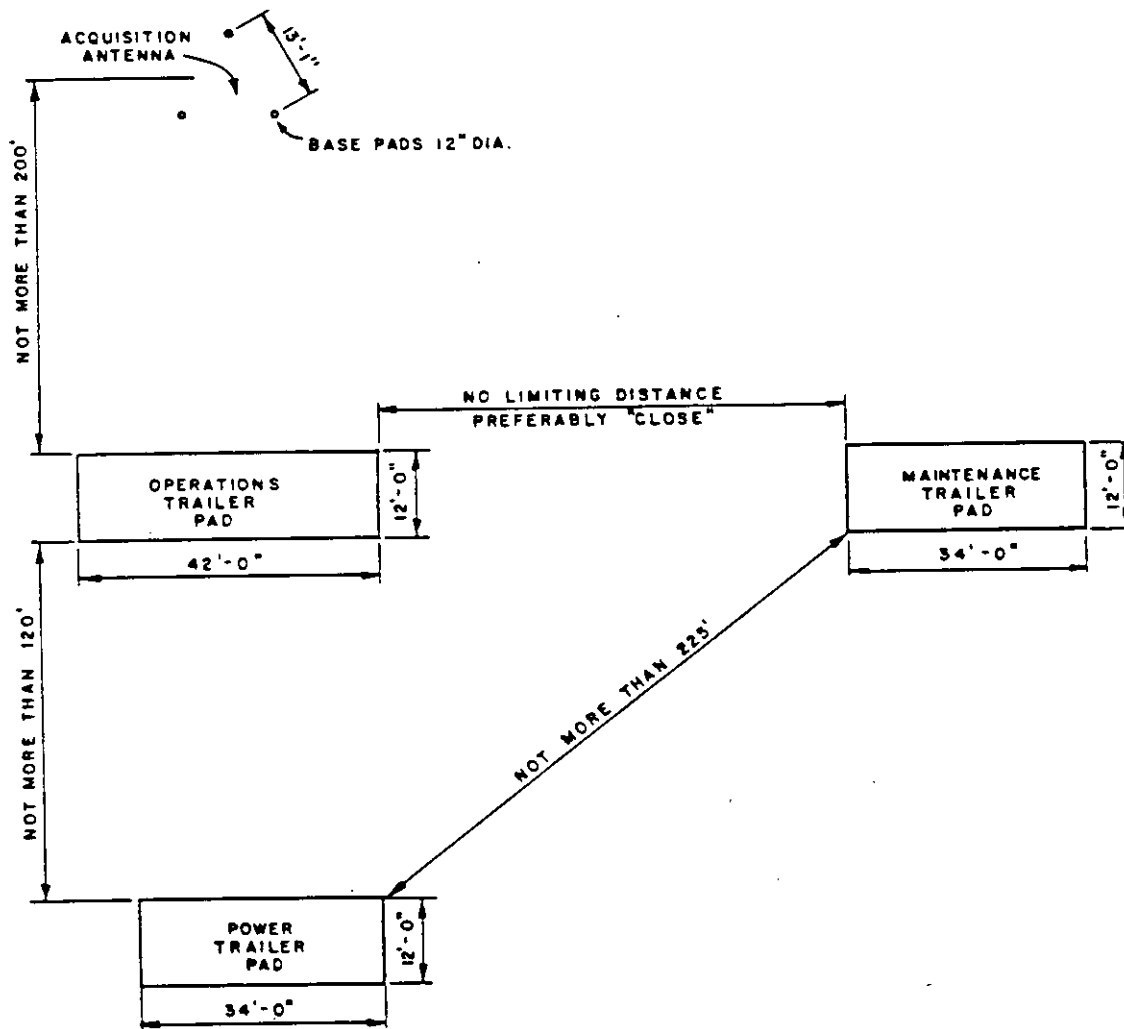

<p>TITLE: RBS-TYPICAL LAYOUT</p>	<p>DATE OCT 87</p>	<p>FACILITY PLATE NO. 179- 70</p>	<p>SHEET 2</p>
--------------------------------------	------------------------	---------------------------------------	--------------------

MIL-HDBK-1027/3A

Section 5: RANGE TOWERS

5.1 Function. The operational tower is used as an observation station at aircraft gunnery, bombing, and rocket ranges for scoring and control of all range activity. Included under operational towers are control (or main) tower and spotting (also called side, rake, or flank) towers.

5.2 Location. A control range operations tower and at least one spotting tower shall be located so that accurate three-dimensional rake information can be obtained. Refer to paras. 4.7.1 and 4.7.4 through 4.7.6 for tower locations at the various ranges. Towers shall be sited so as to obtain an unobstructed view of the target areas and aircraft using the range.

5.3 Architectural Requirements. Refer to Facility Plate No. 179-35, Sheet 1, for one type of control tower. Layout should be planned to take into consideration proper egress and fire exits particularly where bunking facilities are required (refer to MIL-HDBK-1002/1). Towers may contain range and bearing radar equipment, photo-electric or mechanical timing devices, target rakes or theodolites, a dive-angle "harp" to obtain data during dive-bombing exercises remote scoring device recorders, plotting boards, radio equipment for two-way communications with aircraft, and telephone or radio equipment for communications with the supporting station. One type of manned spotting tower is shown in Facility Plate No. 179-35, Sheet 2. Size and height of towers for electronic scoring systems depend primarily upon equipment requirements. These facilities are generally unmanned but must be air conditioned because of the electronic equipment. Towers should be fireproof and provided with smoke detectors. Requirements for security should be determined during planning stage. Criteria to be followed should be requested.

5.3.1 Electronic Scoring Systems. The Weapons Impact Scoring Set (WISS) is a manned video scoring set which scores the impact of air-to-ground delivered ordnance within a 4,000-ft (1,219.2 m) radius of a defined land target under day or night conditions. The impact results are passed to aircrews by UHF communication and/or recorded on a computer printout. WISS spotting tower will house TV cameras and communication equipment for reporting to the range control center. Where located in remote and inaccessible areas, the towers will be fenced for security (refer to NAVFAC DM-5.12). Glass for camera portholes shall be bullet-resistant to rifle ammunition.

5.3.2 Support Facilities. For ranges which do not use the electronic scoring systems, facilities should be sized for personnel as described in Table 6.

5.4 Mechanical Requirements. Refer to NAVFAC DM-3.03 and Facility Plate No. 179-35, Sheet 3, for criteria for plumbing, heating and air conditioning requirements.

5.5 Electrical Requirements. Refer to MIL-HDBK-1004/1, for electric power criteria, and to Facility Plate No. 179-35, Sheet 3, for electrical requirements.

MIL-HDBK-1027/3A

Table 6

Range Types and Facility Sizing for Tower Personnel

Type of Range	Control Tower	Spotting Tower
Strafing		Two men (minimum)
High-altitude bombing and aerial mining	Two men (minimum)	Two men
Multipurpose target	Four men (minimum)	Two men
Loft bombing	Six men (minimum)	Two men
Close air support and combat training area	Three men (minimum)	Two men
Firefighting	Varies according to amount and type of equipment.	

MIL-HDBK-1027/3A

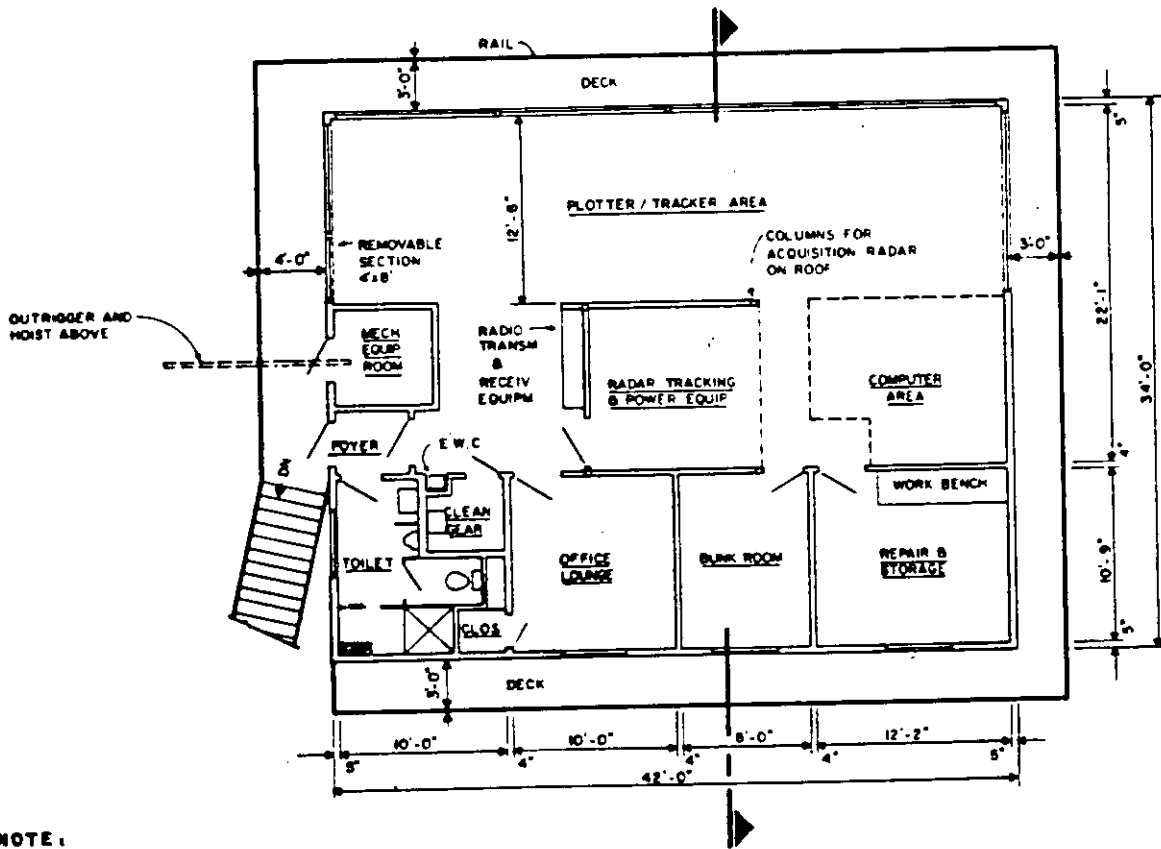
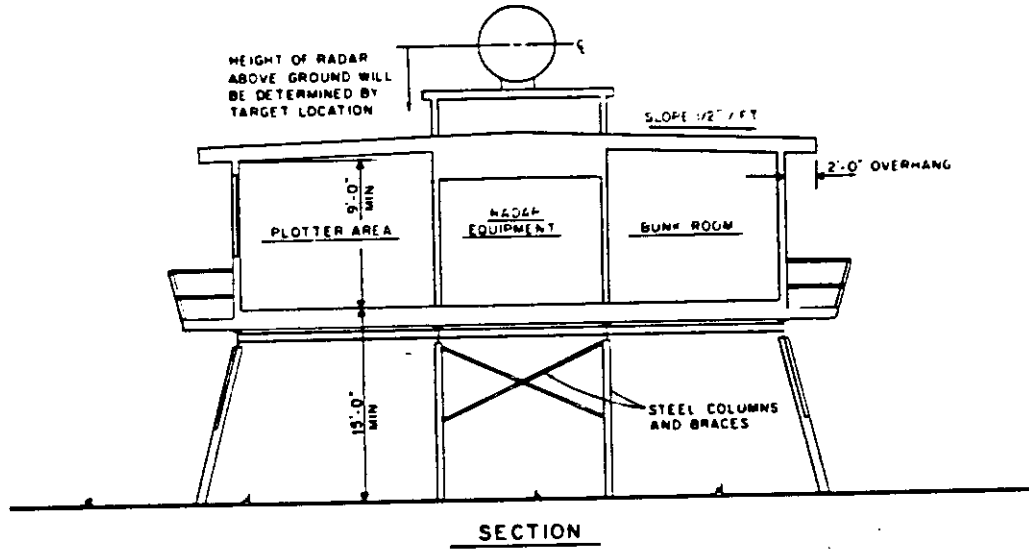

TITLE :

CONTROL TOWER

DATE
OCT 87

FACILITY PLATE NO.
179- 35

SHEET
1

MIL-HDBK-1027/3A

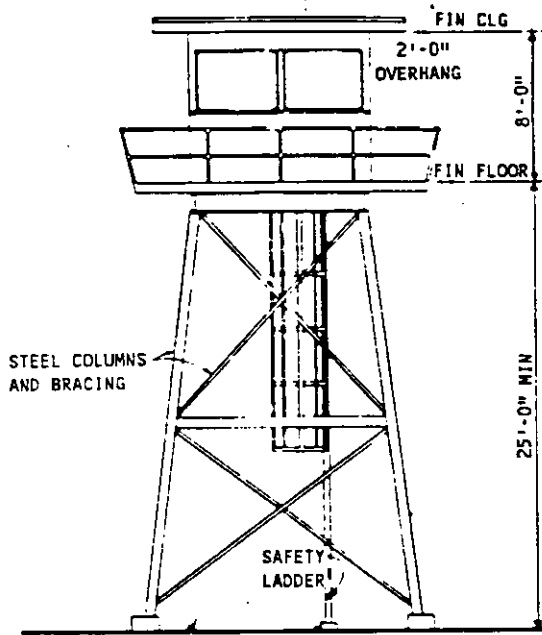

REAR ELEVATION

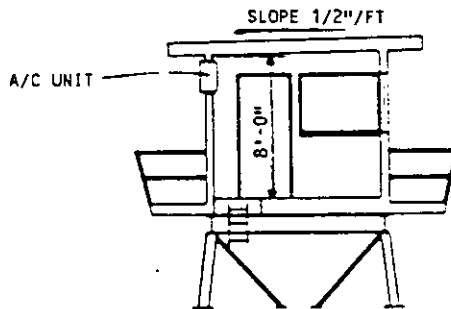

SECTION

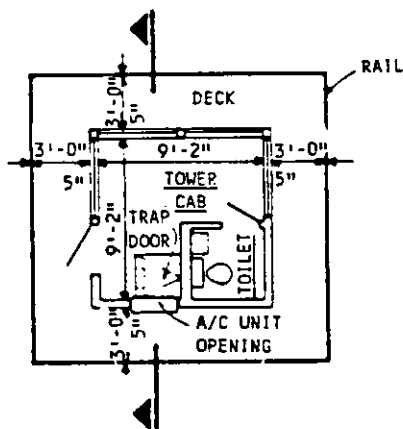

FLOOR PLAN - SPOTTING TOWER

NOTE:
REFER TO SHEET 3
UTILITIES.

TITLE:

SPOTTING TOWER

DATE

OCT 87

FACILITY PLATE NO.

179-35

SHEET

2

MIL-HDBK-1027/3A

NOTES

PLUMBING REQUIREMENTS

	<u>CONTROL TOWER</u>	<u>SPOTTING TOWER</u>
COLD WATER	40 G.P.M.	40 G.P.M.
HOT WATER		
RECOVERY RATE	20 G.F.M.	0 G.P.M.
(THRU 100°RISE) []		
STORAGE	30 GAL	0 GAL

HEATING REQUIREMENTS (M BTU/HR)

INSIDE DESIGN TEMPERATURE	70°F			
OUTSIDE DESIGN TEMPERATURE				
	<u>-5° F</u>	<u>+5° F</u>	<u>+15° F</u>	<u>+25° F</u>
CONTROL TOWER	86	74	63	51
SPOTTING TOWER	6	5	4	3

AIR CONDITIONING REQUIREMENTS

	<u>CONTROL TOWER</u>	<u>SPOTTING TOWER</u>
INSIDE DESIGN TEMPERATURE	75°F.D.B.	75°F.D.B.
INSIDE DESIGN HUMIDITY	50%	50%
OUTSIDE DESIGN TEMPERATURE	95°F.D.B.	95°F.D.B.
OUTSIDE DESIGN TEMPERATURE	78°F.W.B.	78°F.W.B.
COOLING LOAD MBTU/HR	65	6

ELECTRICAL REQUIREMENTS (KW)

	<u>CONTROL TOWER</u>	<u>SPOTTING TOWER</u>
LIGHTS		
CONNECTED LOAD	4.6	1.0
ESTIMATED DEMAND	4.3	0.8
POWER		
CONNECTED LOAD	20.0	1.0
ESTIMATED DEMAND	16.0	0.8
TOTAL		
CONNECTED LOAD	24.6	2.0
ESTIMATED DEMAND	20.3	1.6
ADDITIONAL DEMAND FOR AIR CONDITIONING	9.7	2.0

AREAS

GROSS AREA INCLUDING MECHANICAL EQUIPMENT ROOM	1428 SF	100 SF
--	---------	--------

TITLE : UTILITIES-CONTROL
AND
SPOTTING TOWERS

DATE
OCT 87

FACILITY PLATE NO.
179-35

SHEET
3

MIL-HDBK-1027/3A

MIL-HDBK-1027/3A

Section 6: PROJECTILE RANGES

6.1 Related Criteria. The designer of projectile ranges and ranges outlined in Sections 7 and 8 must apply the requirements contained in MCO P3570.1A, Policies and Procedures for Firing Ammunition for Training, Target Practice, and Combat. MCO P3570.1A includes ballistic data affecting surface danger zones.

6.2 Design Factors. Areas within the total surface danger zones applicable to ranges for field artillery cannon, tank cannon, antiaircraft cannon firing at aerial targets, air defense weapons firing at aerial and ground targets, mortars, rocket launchers, recoilless rifles, field artillery trainers, and cannon launched guided projectiles are described in the text. See Figure 10 for a composite diagram of various ranges which shows the firing line, impact areas, and target area that must be considered in laying out a range or a complex of ranges. The designer must refer to MCO P3570.1A for specific range dimensions. Area A is the lateral danger area. Area B is the downrange danger area. A and B are named secondary danger areas for direct fire mode. Area C is the danger area adjacent to the near edge of the impact area. Area C may be named a secondary danger area for indirect fire mode. Area D is the danger area located between danger Areas C and E. Area E is the danger area located immediately in front of the firing positions. Distance X will be equal to the maximum range of the weapon at the elevation to be fired and for the charge used. Paras. 6.2.1 through 6.2.4 contain descriptions of the areas in Figure 10.

6.2.1 Target Area. Width of target angle and target area depends on number of stationary targets or traversing distance of moving targets. The far edge limit of the target area is set by maximum range of weapon or maximum range of weapon at maximum allowed quadrant elevation. The near edge limit of the target area is set by minimum range of weapon. Provide Z-marked stationary targets within target area of known distances from firing line to use as zeroing targets.

6.2.2 Impact Area. Impact area includes the target area of required target angle and depth expanded in width and depth in terms of Probable Error (PE) of weapon (see Figure 10), to provide safety factors for impacts outside the target area because of mechanical errors, gun instability, and ordnance dispersion. For moving targets the impact area includes additional lateral areas within right and left limit angles. For firing in direct mode, the impact area includes additional lateral ricochet areas.

6.2.3 Firing and Maneuvering Area. The size and shape of firing and maneuvering areas depend upon the number of weapons, types of weapons, and nature of firing exercises. Ranges shall accommodate more than one type of weapon, and the firing and maneuvering area shall be sized and shaped for the most space-demanding firing exercise.

- a) Firing circle for single cannon or single tank firing and maneuvering.
- b) Firing line for row of weapons firing forward.
- c) Rectangular area for maneuvering and firing short-range at

close-up stationary or moving targets immediately in front of firing and maneuvering area, or may be for maneuvering and firing at long-range targets.

6.2.4 Buffer Area. Firing on adjacent or superimposed range may necessitate buffer area immediately in front of firing and maneuvering area and close-up target area to protect personnel occupying firing and maneuvering area.

Unprotected personnel occupying the maneuver and firing area or Area E, must be separated from engaged targets by a minimum distance equal to the engagement distance given in Table 11-1, MCO P3570.1A. This serves as a buffer area to protect personnel from hazardous fragments from the firing of high explosive projectiles at hard or fragment-producing targets.

6.3 Cannon Maximum Range. For delimiting safety zones, consider approximate maximum ranges for standard firing-table conditions. Local conditions may dictate some departure from these.

6.4 Cannon Except Tank and Aircraft Cannon. Criteria for designing projectile ranges for cannon except tank and antiaircraft cannon, mortars, rocket launchers, and recoilless rifles are given in following paragraphs. Included are: Howitzer, 105 mm; Howitzer, 155 mm; gun, 175 mm; gun, 8 inch; gun, 90 mm (firing antipersonnel-type "Beehive" cartridges); Howitzer, 105 mm (firing antipersonnel-type "Beehive" cartridges); Field artillery trainer, M31 (firing 14.5 mm ammunition with charge 1 propellant); and M/12 cannon-launched guided projectile (Copperhead).

6.4.1 Definitions. See Figure 10 for general layout applicable to field artillery cannon ranges and to projectile firing weapons. Design first requires an available surface danger zone large enough to accommodate the required impact area for the planned exercise with the weapon (or the several to be used) that requires the greatest firing angle and the longest maximum range (distance X).

a) Area A and B. Area A provides lateral buffer area; Area B provides depth buffer area around periphery of impact area.

b) Area C. Borders the near side (the minimum range edge) of the impact area and may be occupied by protected personnel during indirect firing of field artillery cannon. Use of Area C must be wholly in control of the Navy Range Officer.

c) Area D. A minimal danger area over which field artillery cannon may be fired in indirect mode while area is occupied. Use of Area D must be wholly under U.S. Government control.

d) Area E. Applies to field artillery cannon. Hazardous during indirect firing because of overpressure, noise, and ground and muzzle debris. Area E shall be unoccupied during all conditions of direct fire. During indirect firing, personnel must be protected by splinterproof cover.

e) Area F. Subject to hazards from back blast from recoilless rifles, rocket launchers, and missiles.

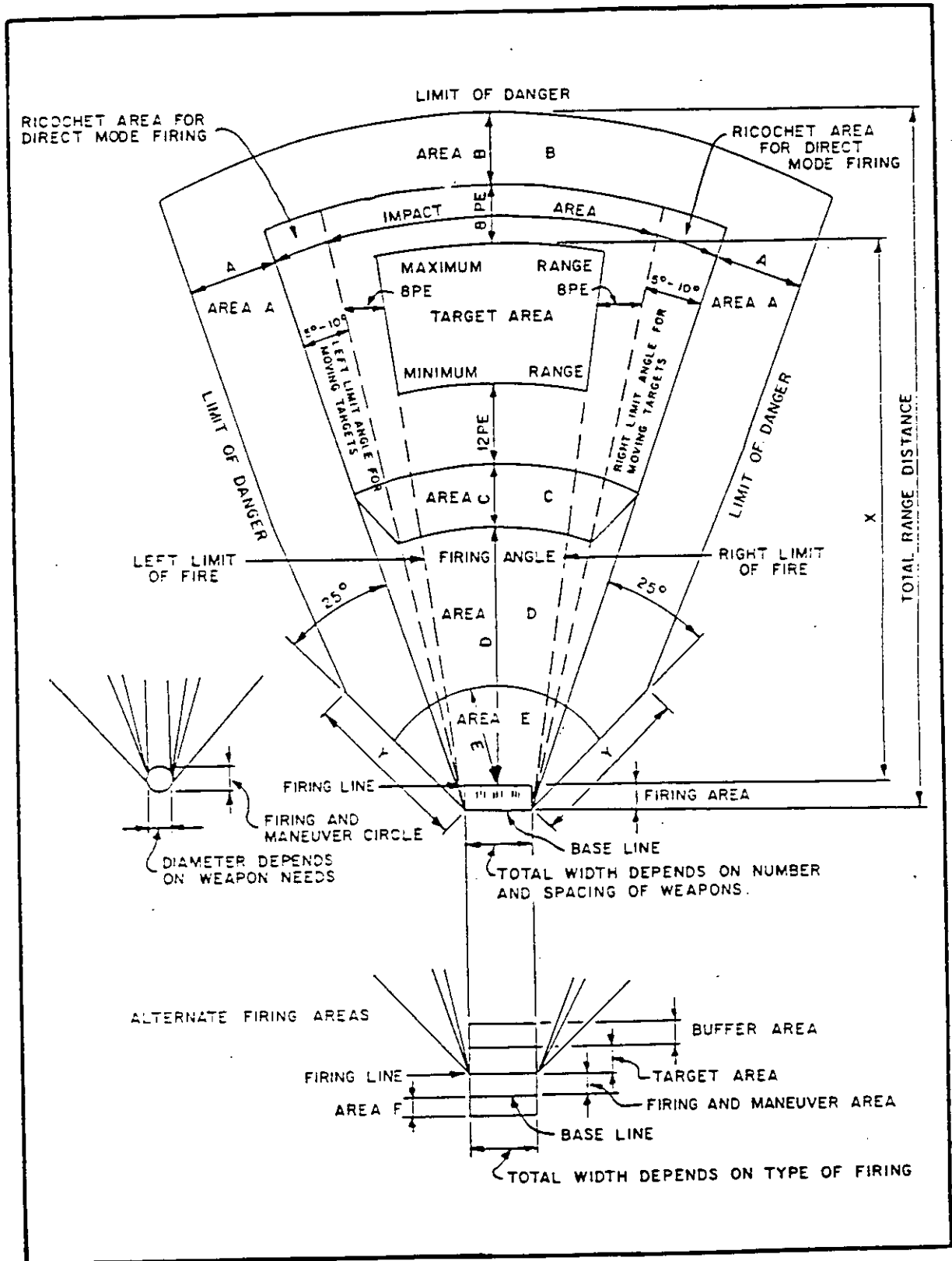

Figure 10

Projectile Range Danger Zones

MIL-HDBK-1027/3A

6.4.2 Surface Danger Zone. For firing at fixed or moving terrestrial targets, the surface danger zone consists of the impact area and the areas in Figure 10 as A, B, C, D and E. Figures and Tables are references to MCO P3570.1A. Variations in dimensions A, B, C, and E for 105 mm howitzer, 155 mm howitzer, 175 mm gun, and 8-inch gun are given in Table 11-1.

Surface danger zone criteria and variations in distance "X" and dimension "Y" for 90 mm gun and 105 mm howitzer firing antipersonnel-type "Beehive" cartridges are given in Figure 11-4 and Table 11-6. Surface danger zone criteria and variations in dimension "A" (lateral ricochet distance) and dimension "B" (downrange ricochet distance) for M31 field artillery trainer firing 14.5 mm ammunition with charge 1 propellant are given in Figure 11-5 and Table 11-7.

Surface danger zone criteria for M/12 cannon launched guided projectile "Copperhead" are shown in Figure 11-6 and Figure 11-7.

6.4.3 Impact Area. For field artillery cannon firing in direct or indirect mode, the dimensions of the impact area shall be not smaller than plus 8 and minus 12 range probable errors in depth by plus or minus 8 deflection probable errors in width, measured from the perimeter of the target area. For this computation, use the probable errors contained in the firing table corresponding to the range and related to the center of the impact area.

6.4.4 Maximum Range. Distance X for field artillery cannon shall be not less than the maximum range of weapons to be fired. In low-angle fire, this distance shall be not less than the range of the weapon corresponding to an elevation of 15 degrees (267 mils) for the charge used.

6.5 Tank Cannon. Criteria for designing projectile ranges for tank, M551, and CEV-mounted projectile firing weapons are given in the following paragraphs for 90 mm, 105 mm, and 152 mm (conventional ammunition) guns; 152 mm SHILLELAGH missile; and 165 mm Combat Engineer Vehicle (CEV).

6.5.1 Surface Danger Zone. The requirements for impact areas, danger areas, and ricochet areas for tank, M551, and CEV-mounted cannon vary considerably from the range requirements for any other type of weapon because of the flatter trajectory and high muzzle velocity of tank cannon. Determine surface danger zone for 5 degrees (89 mils) maximum quadrant elevation for type of weapon to be fired. (See Figures 12-1, 12-2, 12-3, and 12-4, MCO P3570.1A.)

6.5.2 Tank Grenade Launchers. See Figure 12-5, MCO P3570.1A, for surface danger zone guidelines and personnel cover requirements.

6.5.3 Tank Cannon. Refer to Table 12-1, MCO P3570.1A, for surface danger zone dimension guidelines for tank cannon: Dimensions A, B, X, and direct fire safety distances for unprotected personnel.

6.5.4 Ammunition. The Range Officer shall authorize types of ammunition to be fired.

6.5.5 Subcaliber Tank Weapons. Refer to Table 12-2, MCO P3570.1A, for surface danger zone requirements.

MIL-HDBK-1027/3A

6.5.6 Impact Area and Maximum Range. The length of the impact area, distance X for one or more tanks firing on the move or for single tank cannon direct fire from a static position or for tank cannon crossfire shall be not less than the maximum range of the tank cannon firing the longest range TP or service projectiles permitted to be fired at an elevation of 10 degrees (178 mils). Refer to Table 12-1, MCO P3570.1A, for the maximum ranges of tank cannon, for 105 mm gun, 152 mm gun, and 165 mm gun. This restriction shall not apply to tank-mounted machineguns; the maximum range of these weapons is such that they will fire within the tank cannon safety limits when fired at any elevation. Refer to Table 12-2, MCO P3570.1A, for dimensions of surface danger zone for subcaliber tank weapons.

6.5.7 Other Requirements. Place targets so that no tank cannon will be fired at elevations greater than 5 degrees (89 mils) with the horizontal. The limitation of the length of the impact area to that required at 10 degrees (178 mils) maximum angle of elevation, for the longest range ammunition to be used, does not preclude the use of the higher angles of fire that are possible by using reduced charges or by other means within range limitation.

6.6 Air Defense Weapons Firing at Aerial Targets. Criteria for designing a projectile range for air defense weapons firing at aerial targets are shown in Figure 14-1, MCO P3570.1A, and is established for 20, 30, and 40 mm guns.

6.7 Air Defense Weapons Firing at Ground Targets. Criteria for designing a projectile range for air defense weapons firing at ground targets are shown in MCO P3570.1A, Figure 14-2, and is established for the 20, 30, and 40 mm guns. See Figure 14-2, MCO P3570.1A, for surface danger zone, and refer to Table 14-1 for maximum range.

6.8 Mortars. Criteria are established in MCO P3570.1A for 60 mm, 81 mm, and 4.2 in. mortars; see Figure 10-1 for surface danger zone, and for danger area dimensions, refer to Table 10-1, Dimensions A and B.

6.9 Rocket Launchers. Criteria are established for 35 mm M73 practice rocket, 66 mm M72 Light Antitank Weapon (LAW) rocket, 66 mm M74 incendiary rocket, and 3.5-in. rocket.

6.9.1 Surface Danger Zone. Requirements for surface danger zone for rocket firing differs from other weapons in that a danger area exists to the rear of the launcher as shown in Figure 10, Area F of this handbook. For danger area dimensions and design criteria for designing range for rocket launchers, see Figure 8-1, and refer to Table 8-1, MCO P3570.1A.

6.9.2 Minimum Range. Provide minimum range (see Figure 10) from firing point to nearest target of at least 70 m (230 ft).

6.10 Recoilless Rifles. Range design criteria are established for the 57 mm, 75 mm, 90 mm, 105 mm, and 106 mm recoilless rifles.

6.10.1 Surface Danger Zone. Requirements for surface danger zone for recoilless rifle firing differ from other weapons in that a danger area exists to the rear of the recoilless rifle as shown in Figure 33, Area F. Refer to MCO P3570.1A, Figure 9-1, for firing at quadrant elevation of 15 or more, and Figure 9-2 for firing at quadrant elevation of less than 15, and Table 9-1 for danger area dimensions and design criteria for recoilless rifle ranges.

6.10.2 Firing Points. For row of firing points with weapons firing forward, place firing points at least 65.6 ft. (20 m) apart.

6.10.3 Minimum Range. Provide minimum range from firing point to nearest target of at least 1312 ft (400 m) for weapons to 90 mm caliber, and of at least 1804 ft (550 m) for weapons 90 mm caliber and greater.

6.11 Field Artillery Trainer (Air Pressure). The minimum radius of surface danger zones shall be 13 yd (12 m) plus the distance necessary to provide safety from the ricochet of projectiles, as determined by actual examination of terrain by the local authority. For increases in air pressure, increase the danger area. If an observation post is located close to the line of fire, occupants must be protected by a sloping roof of suitable material.

6.12 Protection of Persons Near Firing Point. When high-explosive ammunition with fuses not classified as bore safe is fired in cannon, protection shall be provided against premature burst in or out of the bore.

6.12.1 Safe Distance. Provide positive protection for all personnel within the following distances from the firing post: 200 yd (183 m) for all calibers up to and including 3-in. (76.2 mm), and 300 yd (274 m) for all calibers over 3 in. (76.2 mm), up to and including 105 mm.

6.12.2 Positive Protection. Positive protection shall consist of one of the following forms:

a) Sandbags. Provide two thicknesses of filled sandbags for all calibers up to and including 3-in. (76.2 mm); use four thicknesses for all calibers greater than 3 in. Heights shall be sufficient to provide cover for personnel standing erect.

b) Trench. Provide a narrow trench of sufficient depth for proper cover; for cannon detachments, the trench shall be perpendicular to the line of fire and to the rear of the cannon.

c) Concrete Walls. Make walls at least one foot thick (0.3 m) and of sufficient height to provide cover for personnel standing erect.

d) Tractors. Group tractors to afford proper protection (temporary).

Section 7: FLAME THROWERS AND GRENADE RANGES

7.1 Flame Throwers. For design criteria, see Figure 14-2 of MCO P3570.1A.

7.2 Grenades. Range design criteria for hand grenades, rifle grenades, grenade launchers, and tank grenade launchers are as defined in paras 7.2.1 through 7.2.5.

7.2.1 Burning Type Hand Grenade. When fired in place, at least 10 m distance for quick retreat of firer to avoid incendiary particles and fumes and at least 10 m throwing distance will be provided.

7.2.2 Fragmentation-type and Bursting-type Hand Grenades. Trench or protective barrier equivalent to a screen of sandbags 0.5 m (20 in.) thick will be provided for personnel within 150 m throwing of bursting point of HE-loaded-type hand grenades. Figure 7-1 of MCO P3570.1A shows surface danger zone for designing fragmentation grenade range. Design distances are:

a) At least 4 m between unprotected personnel and bursting point of white phosphorous burning-type M15 and M34 hand grenades.

b) At least 25 m between unprotected personnel and detonation point of bursting-type riot control M25 hand-grenade.

7.2.3 Rifle Grenades. Rifle grenades are fired from behind protective barrier equivalent to a screen of sandbags 20 in. (0.5 m) thick. At least 200 m between detonation point and unprotected personnel will be provided. Figure 7-3, MCO P3570.1A, shows surface danger zone for designing rifle grenade range.

7.2.4 Grenade Launchers. At least 130 m will be provided between unprotected personnel and grenade detonation point. Figure 7-2 of MCO P3570.1A shows surface danger zone for designing ranges for 40 mm grenade launcher M79 and M203 firing MK19, 40 mm MG (grenade).

7.2.5 Tank Grenade Launchers. Design criteria for range design is established for M176, M226, and M239 grenade launchers in para. 12-7 and Figure 12-5 of MCO P3570.1A.

MIL-HDBK-1027/3A

MIL-HDBK-1027/3A

Section 8: LASER RANGES

8.1 Criteria. Refer to Table 19-1 of MCO P3570.1A for a list of laser devices for which range design criteria are established. Figures and Tables in this section are referenced to MCO P3570.1A.

8.1.1 Planning Factors. Special terms and considerations particularly applicable to laser range design criteria are as follows:

- a) The distance within which the collimated laser beam presents a potential eye hazard, the Nominal Ocular Hazard Distance (NOHD) nonmagnified, is comparable to the maximum range of projectile firing weapons.
- b) The NOHD is greatly increased when viewing the collimated laser beam with a telescope and is termed the magnified NOHD.
- c) Horizontal lateral buffer zones and vertical buffer zones at the periphery of the target area will be determined to accommodate inherent aiming accuracy and stability of laser device being used.
- d) Buffer zones should be greatly expanded for situations liable to involve inexperienced personnel, improper target selection, or inaccurate target designation.
- e) Use of natural backstops (mountains, hills, and treelines) is especially desirable to limit length of Laser Surface Danger Zone (LSDZ).
- f) Airborne laser operations will require LSDZ to be clearly marked, visible, and recognizable from lasing aircraft.
- g) The many types of laser devices and uses in conjunction with range firing, troop exercises, tank maneuvering, and operations outside range areas necessitates careful planning for location and delimiting of target area and LSDZ for each individual exercise.
- h) Steps must be taken to avoid indirect lasing from specular (mirror-like) targets or icy or snowy ground surfaces.
- i) Area S in Figures 19-5 and 19-6 is defined as the 100 ft. (30.5 m) radius around the target from which all specular surfaces should be removed, covered, painted, or destroyed.
- j) Area T in Figures 19-5 and 19-6 is defined as an area distance T from laser firing point within which no targets will be lased.

8.1.2 Design Steps. The target area will be large enough to accommodate laser range danger fan for type of laser device to be used and type of exercise and maneuvering. When the laser device to be used is known, T, S, and NOHD and horizontal and vertical buffer zones can be determined from firing tables. Use of current firing range surface danger zones, in general, will provide conditions and area adequate for safe ground-to-ground lasing if the beam impacts within range impact area. For design criteria refer to the following:

MIL-HDBK-1027/3A

- a) Laser Surface Danger Zone (LSDZ) (refer to Table 19-1).
- b) Laser Range Danger Fan (see Figures 19-5 and 19-6).
- c) Backstops for Laser Ranges (see Figures 19-7, 19-8, and 19-9).

MIL-HDBK-1027/3A

Section 9: PARADE AND DRILL FIELDS

9.1 Siting and Dimensions. The terrain should be relatively flat, with a slight slope for drainage. Consideration should be given to using the parade and drill field for athletic and other recreational activities. Criteria for parade and drill fields follow.

9.1.1 Naval Training Station. Drill field will be 500 x 1,200 ft (152.4 x 365.76 m), centrally located within each 5,000-man group.

9.1.2 Marine Corps Recruit Depot. Parade and drill field will be 900 x 2,500 ft (274.32 x 762 m), adjacent to the troop billeting areas. A drill field within each regimental area will be 500 x 1,200 ft (152.4 x 365.76 m).

9.1.3 Major Marine Barracks. In the billeting area, an adjacent field will be 1,000 x 3,000 ft (304.8 x 914.4 m). In each regimental area, the drill field will be 500 x 1,200 ft (152.4 x 365.76 m).

9.2 Types of Surface. Where erosion is not a serious problem, a well-turfed field is preferable. Water outlets will be located every 250 ft (76 m) along each side of the field. For pavement criteria, refer to NAVFAC DM-5.4.

MIL-HDBK-1027/3A

Section 10: TRAINING COURSE STRUCTURES

10.1 Obstacle Courses. Figure 11 shows a typical layout of an obstacle course. Small crushed gravel should be added to the entire length of the course to a depth of 2 in. (50.8 mm) to provide a firm all weather footing. Details of individual obstacles are shown in Figure 12.

10.2 Confidence Courses. The course will be approximately 200 yd (183 m) long, with obstacles spaced at equal distances along its length. Typical details for confidence courses are shown in Figure 13.

10.3 Combat Towns. Construction will be repairable construction, such as lightweight precast concrete which will withstand projectile impact. Other materials will be acceptable. Combat town provides instruction and practical experience in cordon, search, clearing, and entry techniques in built-up areas or for use in training in controlling civil disturbances.

10.3.1 Size. Area is determined by training requirements, usually several intersecting streets and several multi-story buildings, including maneuver areas extending 300 yd (274.32 m) in all directions from center of facility.

10.3.2 Locations. If live fire exercises are to be conducted (demolition or small arms), appropriate safety zones and impact areas must be designated. Firing inside the structures is permitted if bullets impact approved backstops.

10.3.3 Construction. Structures will be designed to support floors, walls, roofs, and sandbags around doors and windows. Electric utilities at doors and windows will be required if electric/electronic target/scoring systems are used.

Ground level units may be concrete block construction. Upper stories may be wood. Interior will be sheetrock/plywood construction.

10.3.4 Warnings. Red flags or red flashing lights should be provided during daylight hours and red flashing lights from sunset until sunrise from flagpoles approximately 200 yd (183 m) from facility during use of live ammunition.

10.4 Combat Hut. A "combat hut" provides an opportunity for instruction in, and development of, advanced live fire techniques and execution of cordon, search, clearing, entry, and hostage recovery scenarios. Live-fire scenarios must be designed to be as realistic as possible. Design guidance may be received from: FBI Academy, Quantico, VA; Federal Law Enforcement Academy, Glynco, GA; National Rifle Assn. (Range Development Dept.), Washington, D.C.; NAVFACENGCOMHQ, Alexandria, VA; Weapons Training Dept., U.S. Naval Station, Annapolis, MD.

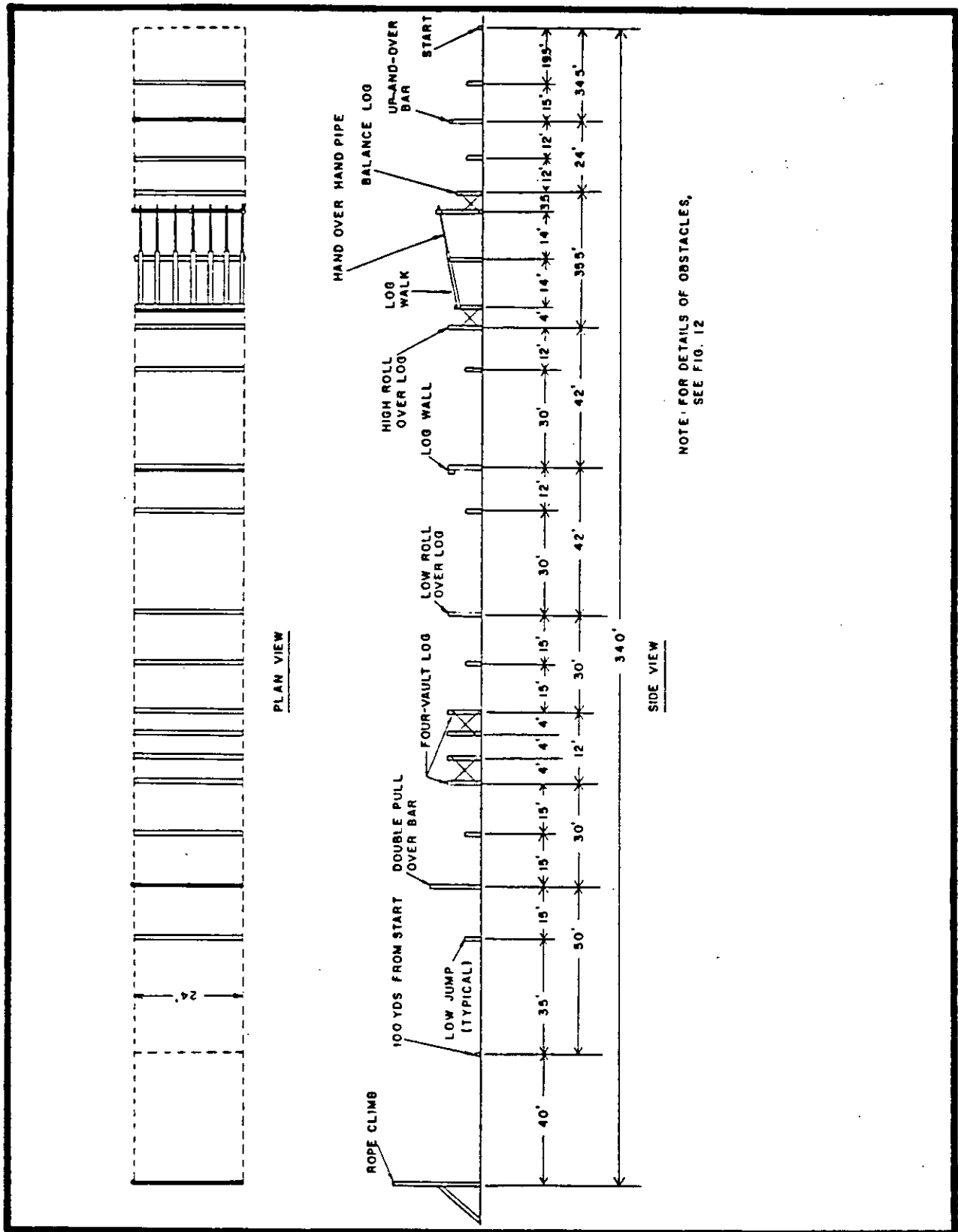

Figure 11

Typical Obstacle Course Layout

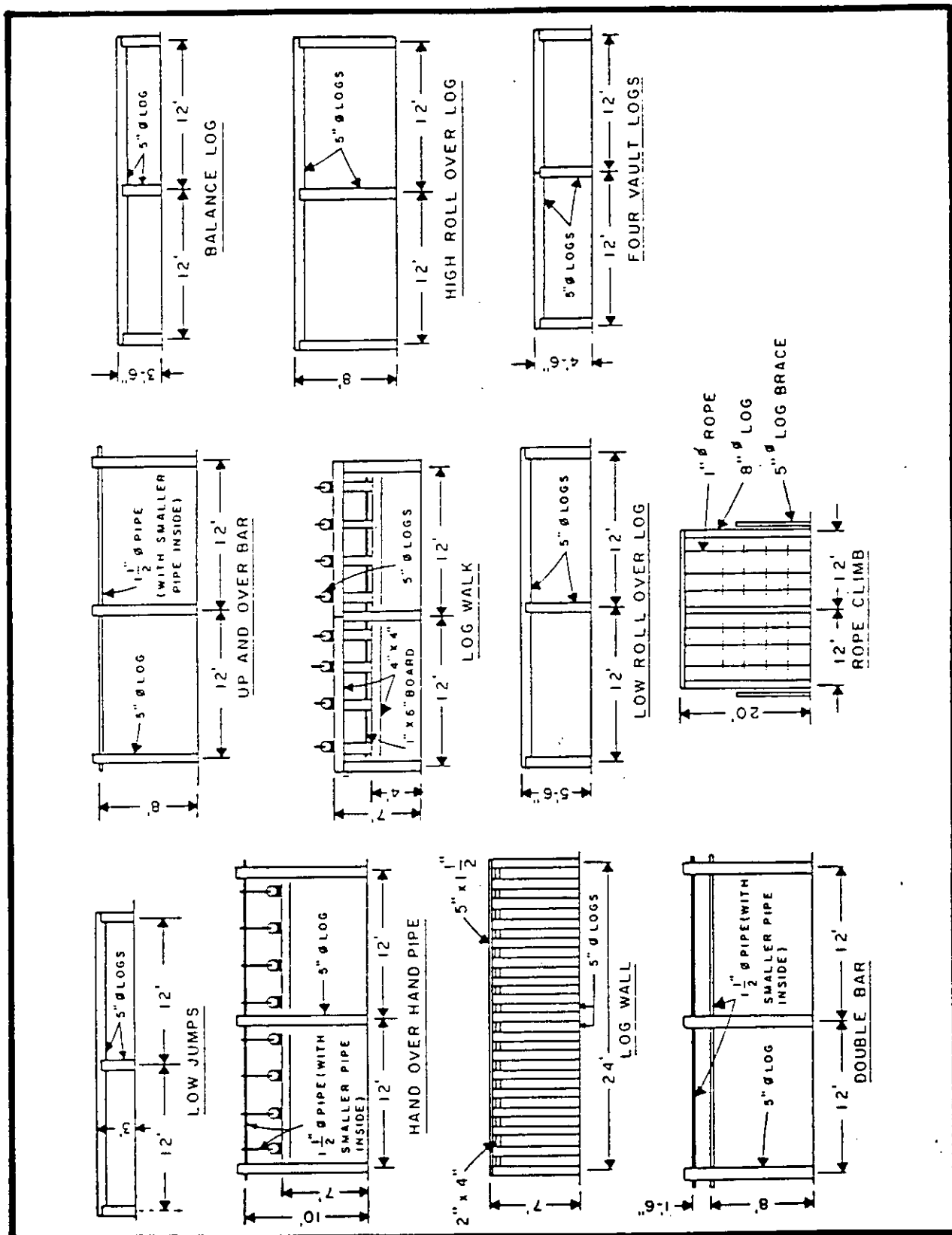

Figure 12

Details of Obstacles

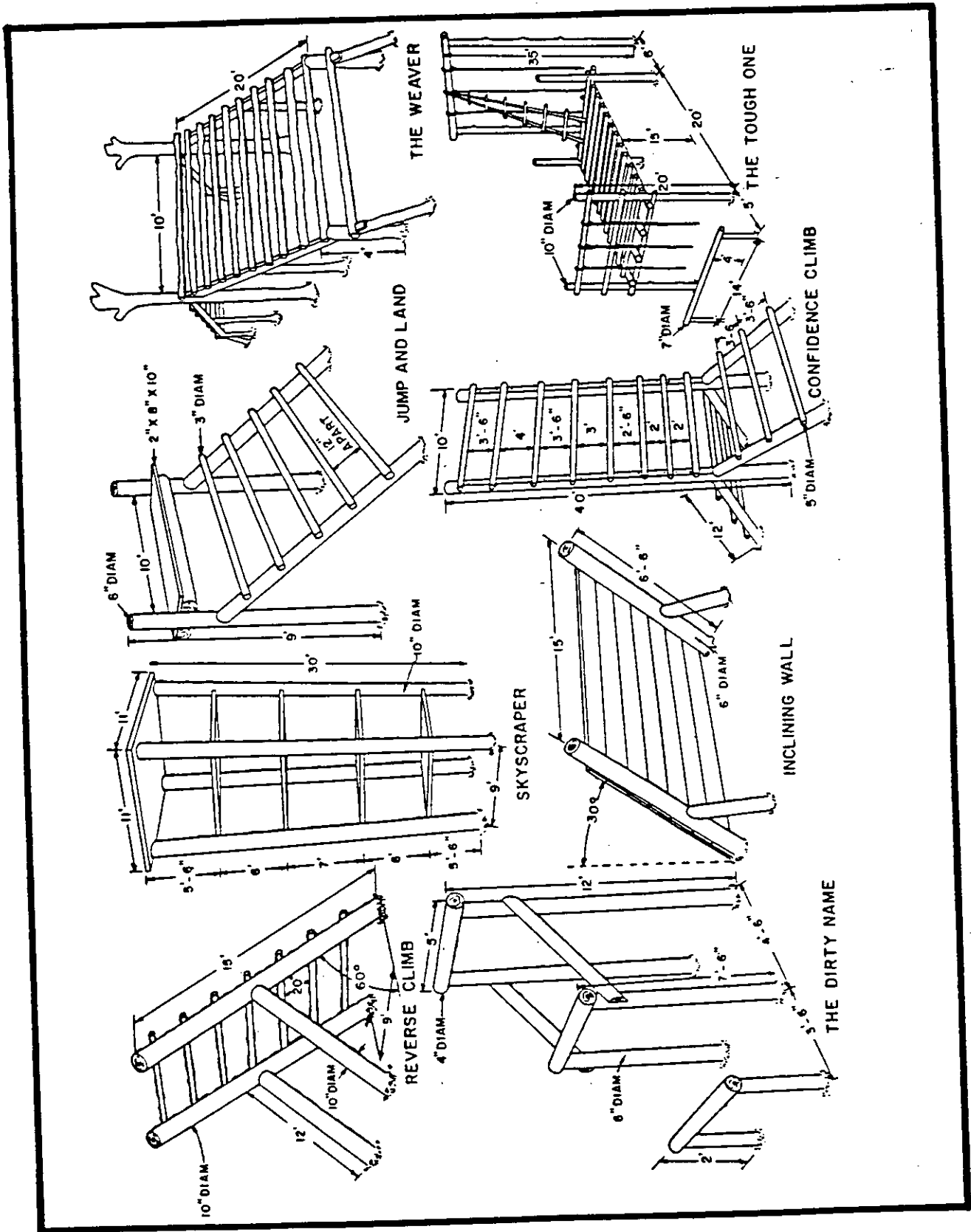

Figure 13

Confidence Course Obstacles

APPENDIX A: WARNING SIGNS AND ADDITIONAL FIGURES

Refer to AR 385-30, Safety Color Code Markings and Signs.

WARNINGS	LOCATIONS
Danger--Firing in Progress When Red Flag is Flying	Approach Roads
Danger--Firing Ranges Do Not Enter	Fencing and Barriers
Danger--Laser	Entry road and 100 ft (30.5 m) intervals on perimeter fencing.

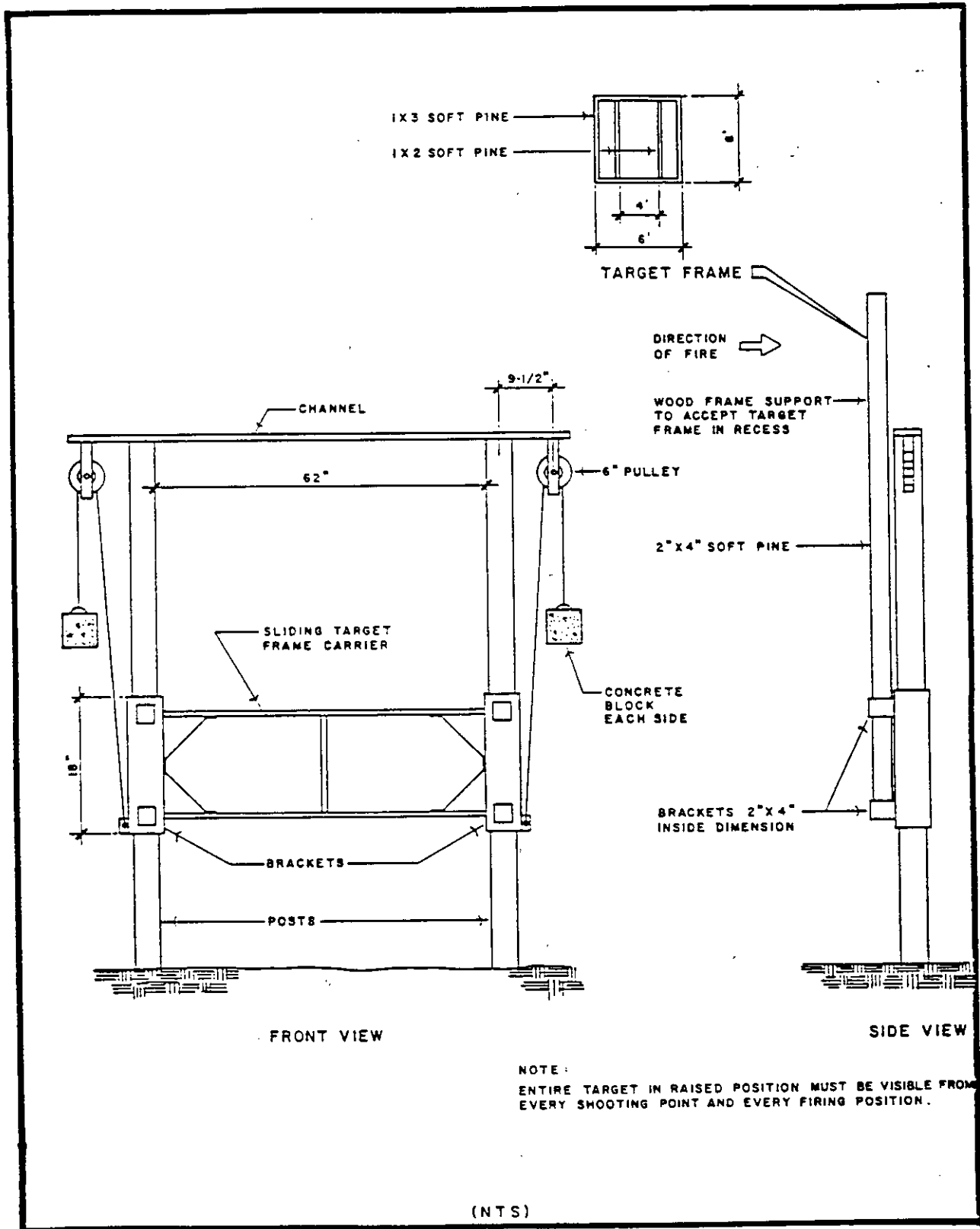

Figure A-1

Rifle Range Target Carrier

MIL-HDBK-1027/3A

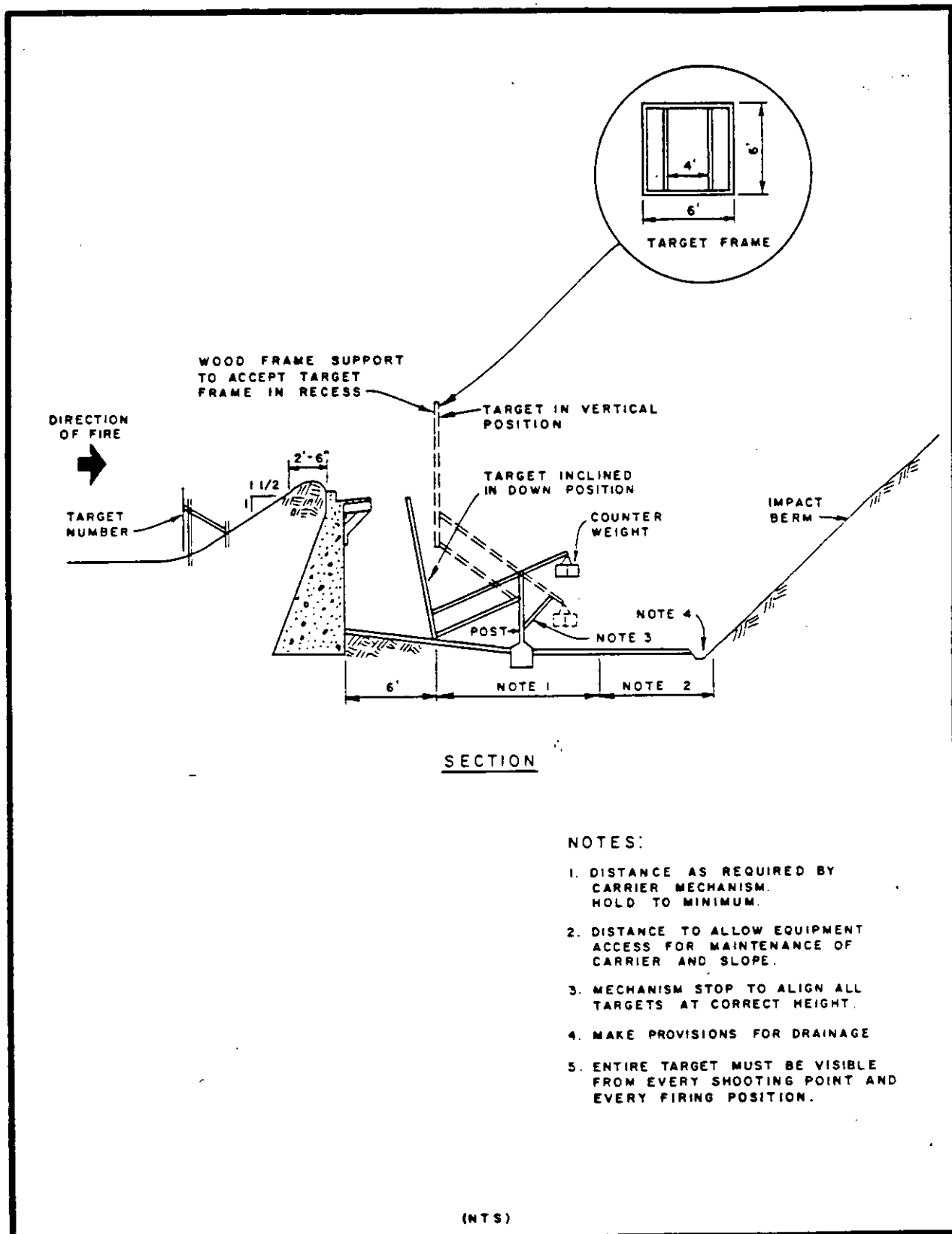

Figure A-2

Paraleg Target Carrier

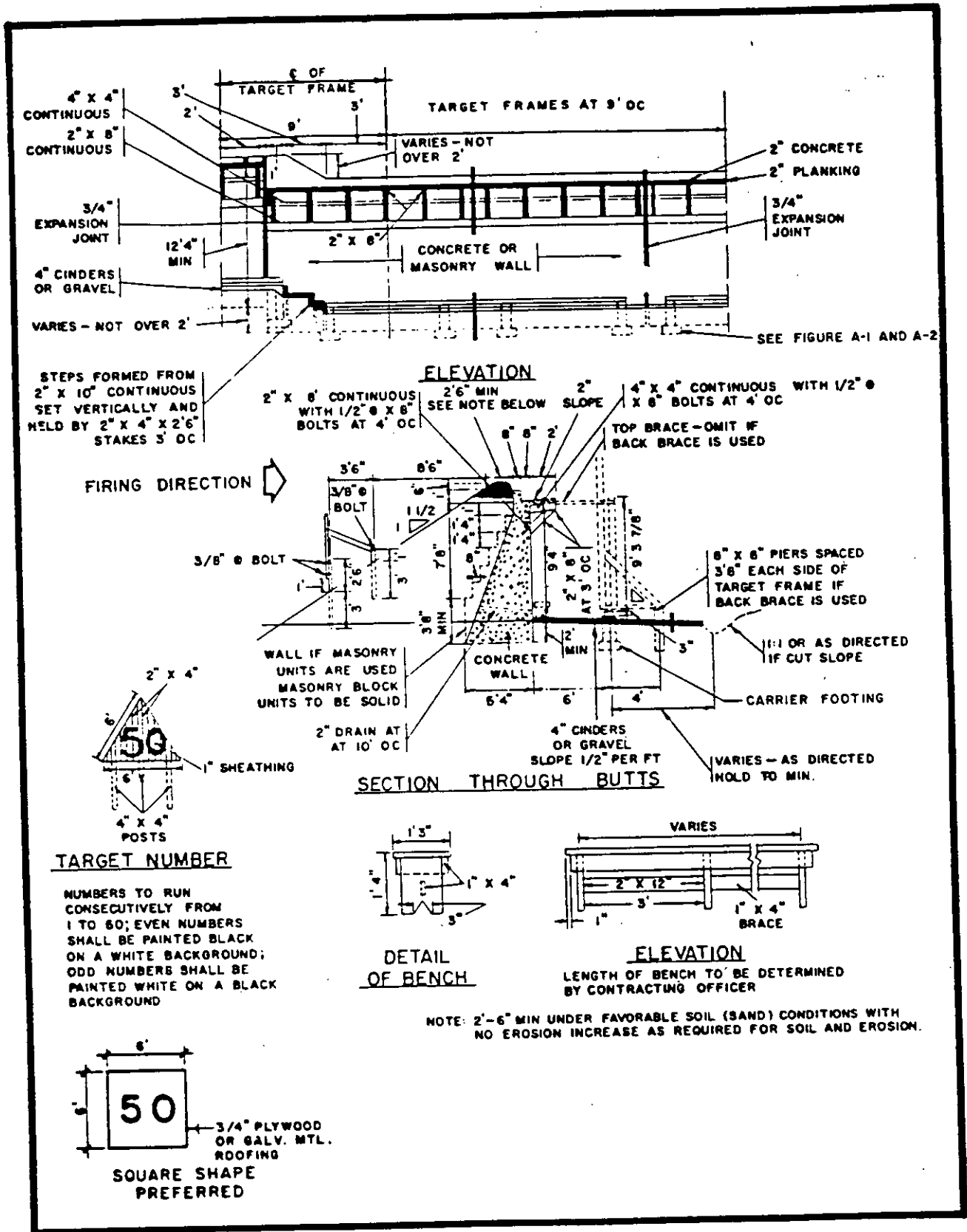

Figure A-3

Target Butts and Details

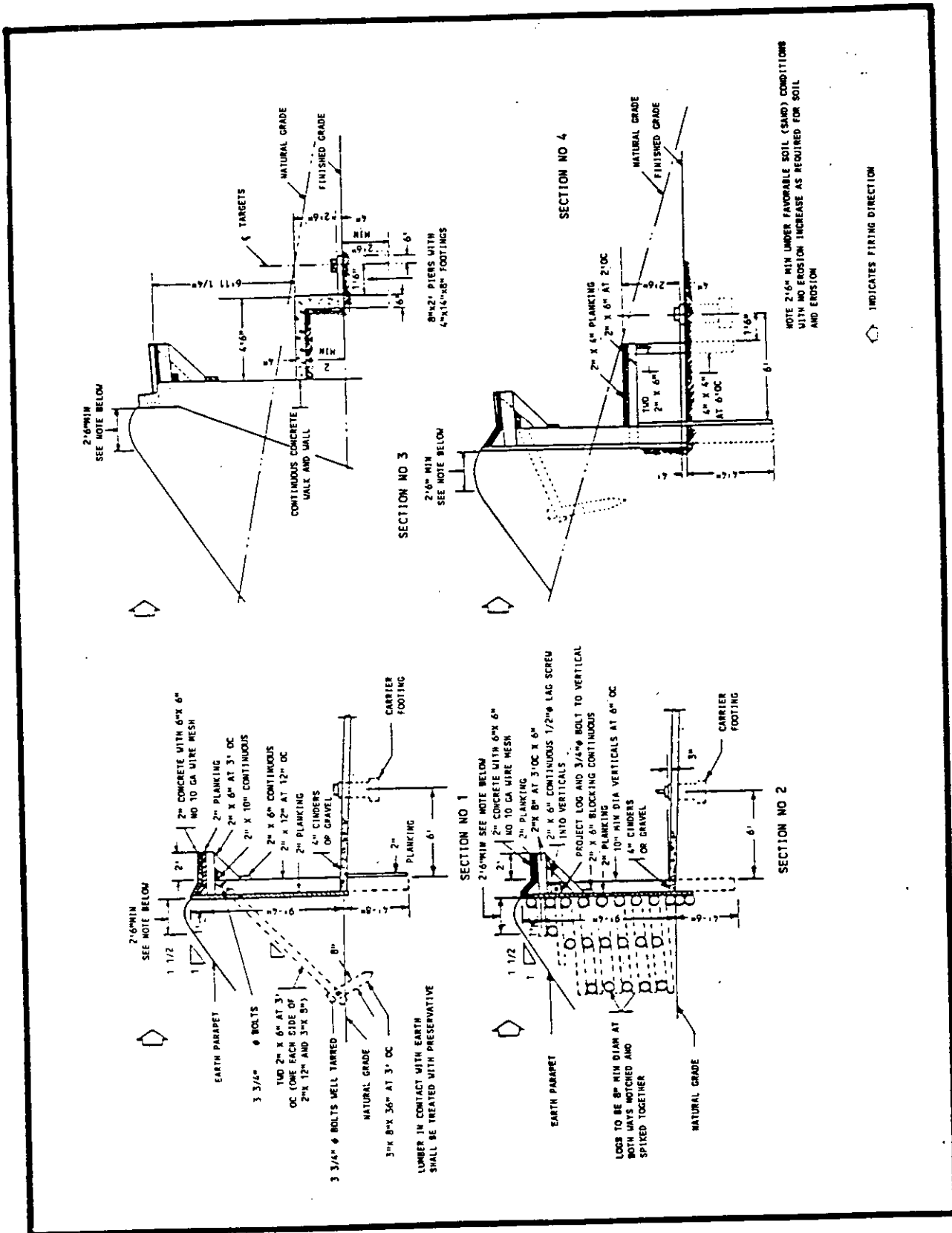

Figure A-4

Alternative Target Butts

MIL-HDBK-1027/3A

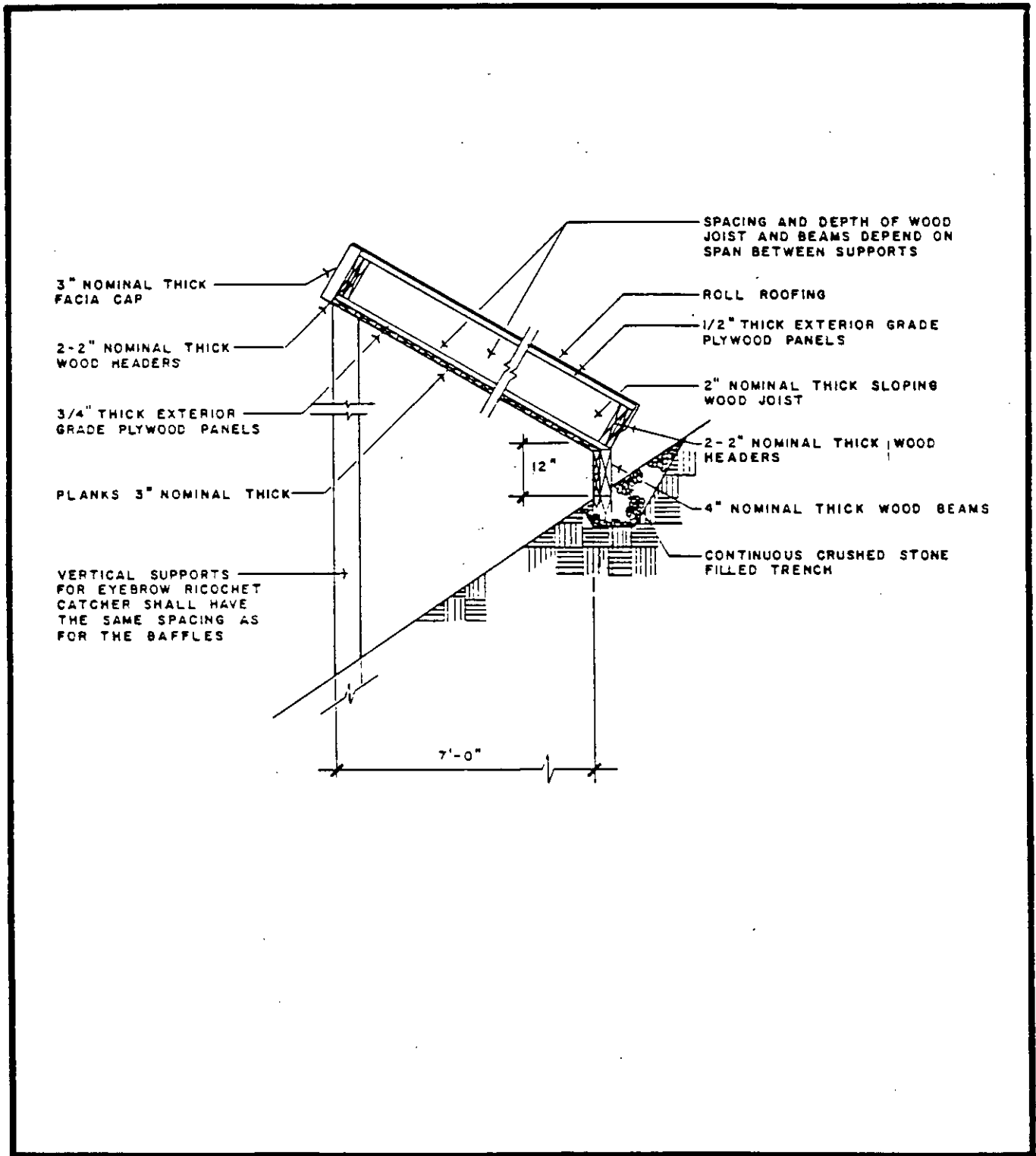

Figure A-5

Eyebrow Ricochet Catcher Detail

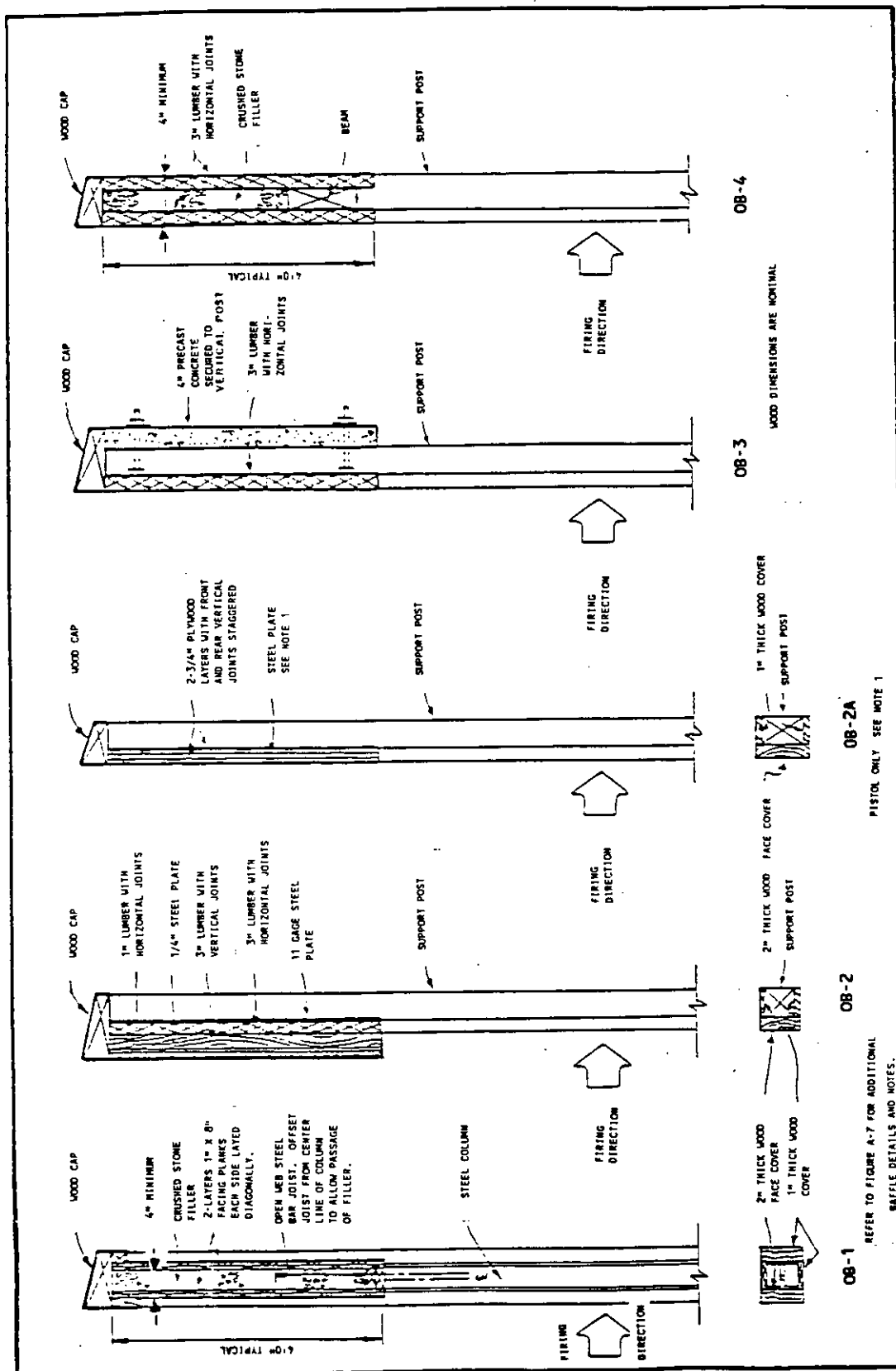
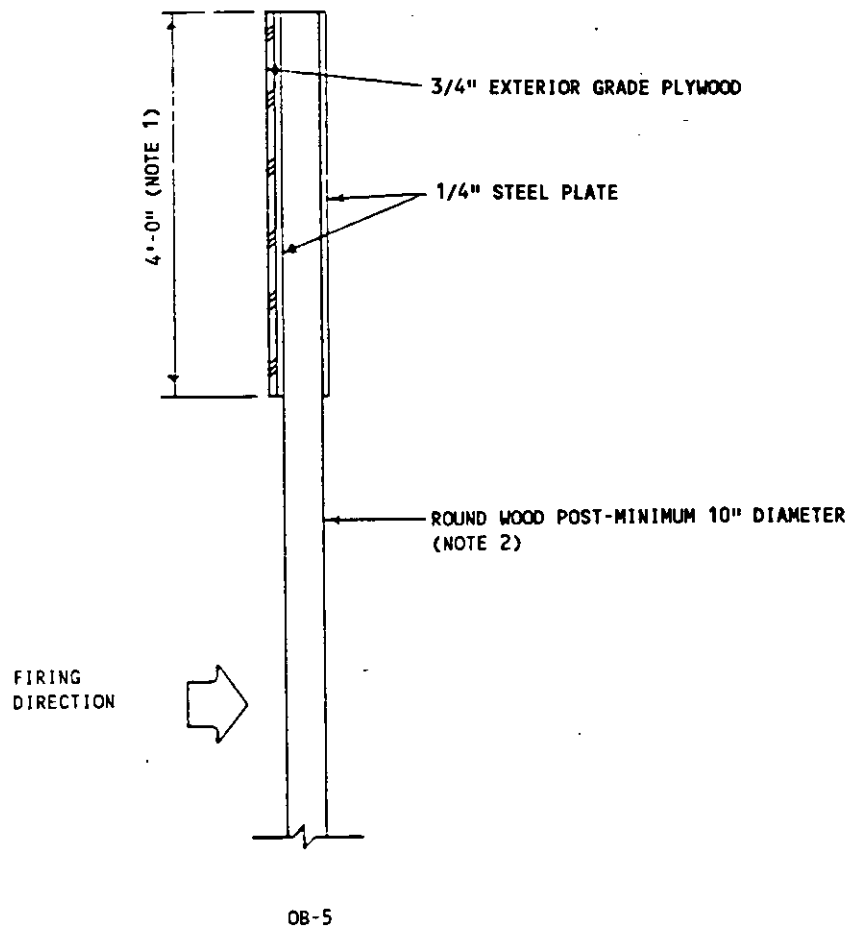

Figure A-6

Overhead Baffles

MIL-HDBK-1027/3A



NOTES:

1. WHEN OB-5 IS USED IN COMBINATION EARTH BERM/BAFFLE, THIS DIMENSION IS FULL HEIGHT OF BAFFLE.
2. FRONT OF POST MAY BE COVERED WITH SACRIFICIAL COVERING OF WOOD OR WOOD COVERED METAL TO ENSURE LONGER LIFE, IF DESIRED.

NOTES FOR FIGURE A-6

1. OB-1,2,3 AND 4 ARE SUITED FOR ALL SMALL ARMS CALIBERS UP TO 5.56 mm BALL AND 7.62 mm/CAL.30 BALL. OB-2A=10GA. PLATE FOR .38 AND .45 BALL OR WAD-CUTTER AMMUNITION; 8 GA. PLATE FOR 9mm AND .357 MAG.
2. SUPPORT POSTS FOR OB-3 AND OB-4 SIMILAR TO OB-2 OR OB-2A
3. REFER TO SEC. 2.5.8.7 FOR FASTENERS EXPOSED ON FRONT OF BAFFLES.

(NTS)

Figure A-7

Overhead Baffle For All Pistol and Rifle Calibers
up to 7.62 mm/30 Cal Ball Ammunition

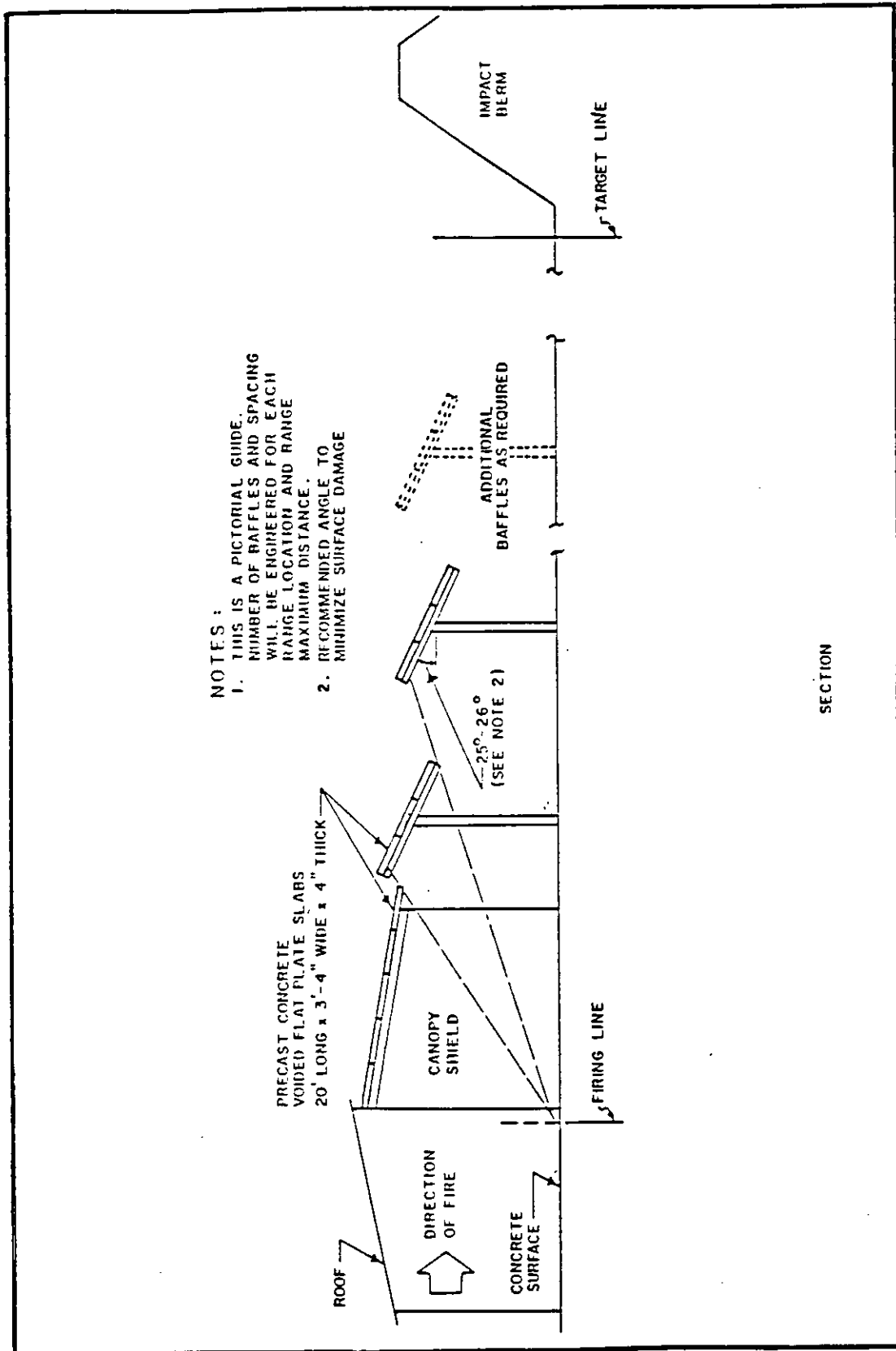
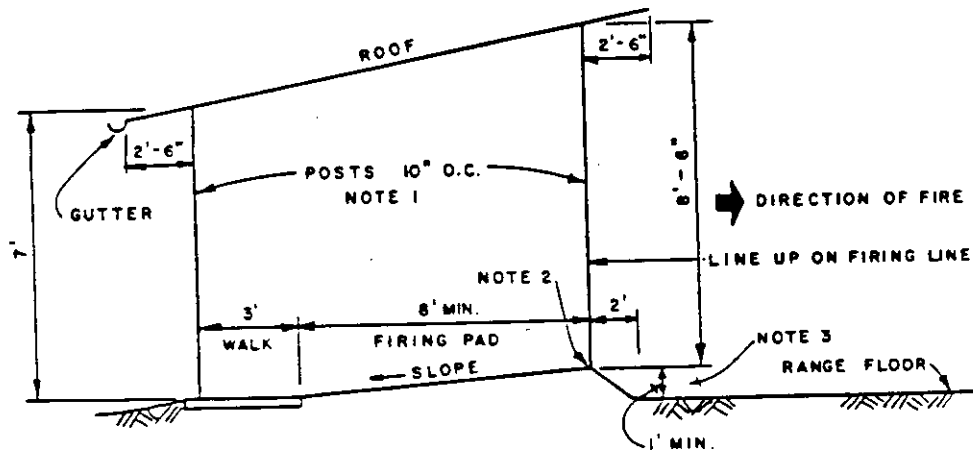

Figure A-8

Alternative Overhead Baffles



SECTION

NOTES:

1. SPACING 10' OR AS REQUIRED FOR FIRING LANE WIDTHS.
2. PAINT STRIPE FOR FIRING LINE IDENTIFY POSITIONS SAME AS TARGET NUMBERS.
3. ELEVATION AS REQUIRED BY TERRAIN SO FIRING POINTS ARE ABOVE TARGET MECHANISM BERMS.

(NTS)

Figure A-9

Firing Line Cover, Open/Impact Range

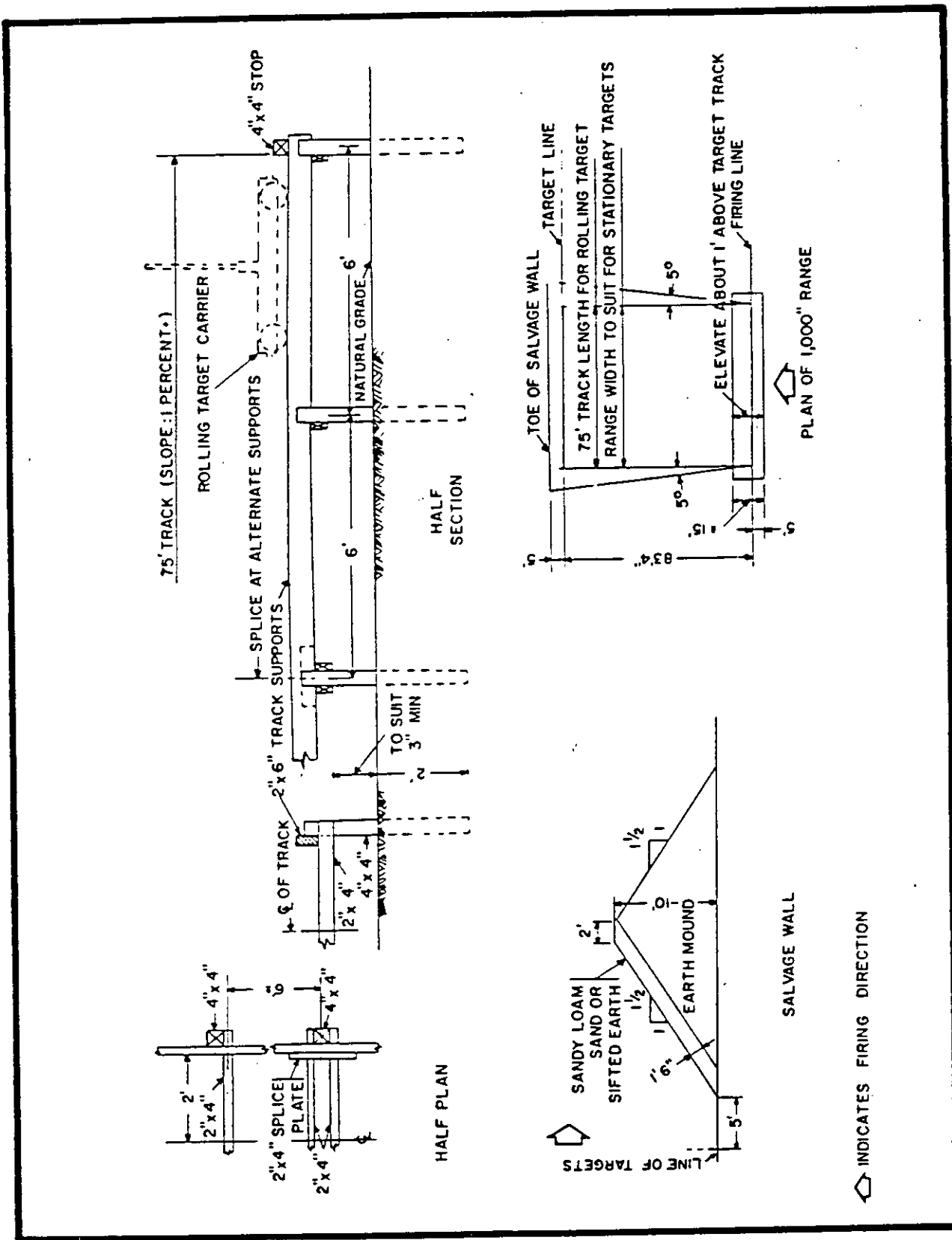

Figure A-10

1000-Inch Machinegun Range and Details of Rolling Target Track Support

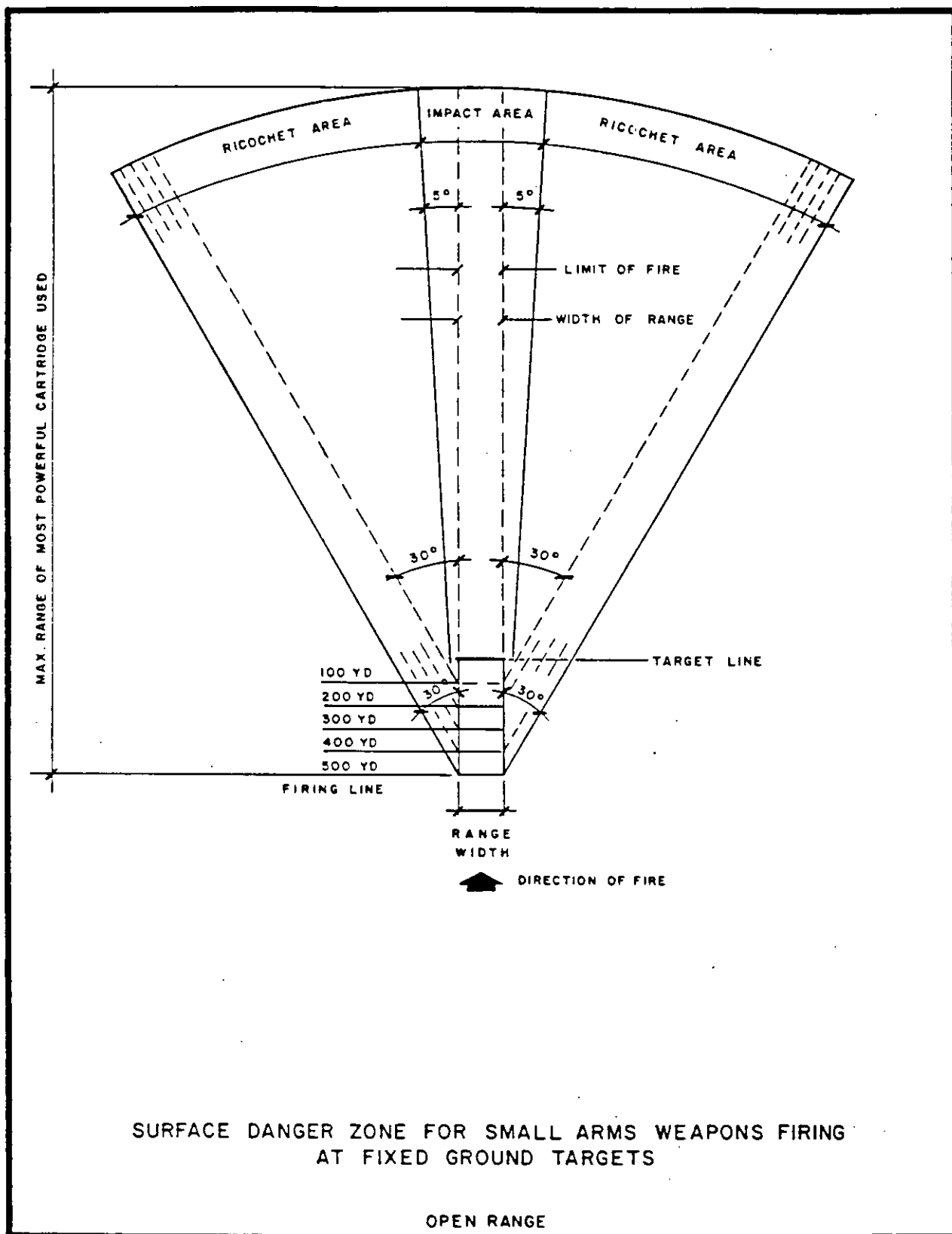

Figure A-11

Open Range With Rocky Soil or Hard Targets Causing Ricochet

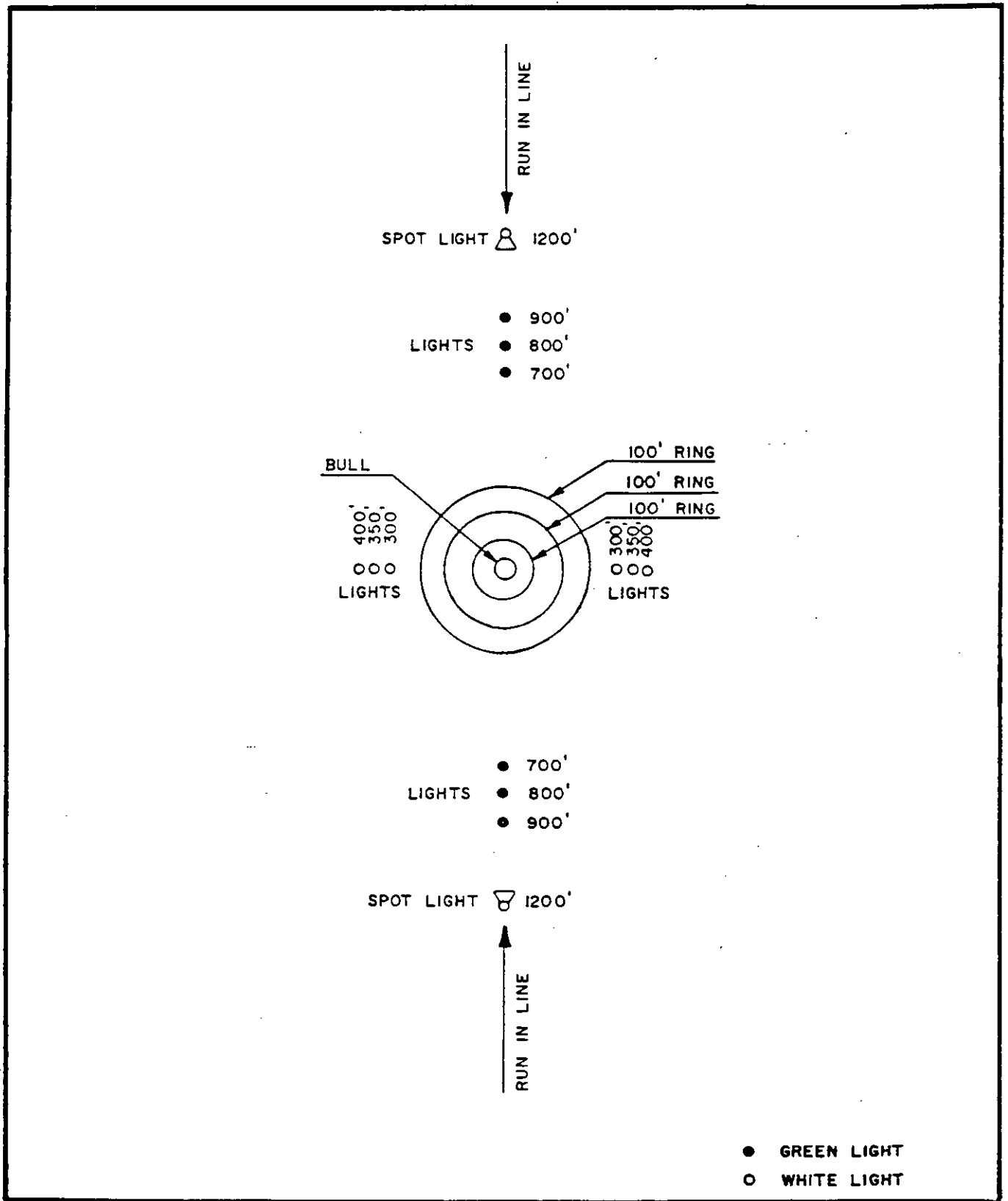

Figure A-12

Bull's Eye Lighting

MIL-HDBK-1027/3A

APPENDIX B: ADDITIONAL INFORMATION AND SUPPLIERS LIST

1. The National Rifle Association publishes information on the design and construction of small arms shooting ranges and other information. Range suggestions may be obtained from the following point of contact:

National Rifle Association
Range Development Department
1600 Rhode Island Avenue
Washington, DC 20036
(202) 828-6190

2. The following partial list of suppliers is provided as an aid to the range designer in making initial contacts during the planning phase of range design.

Bullet Stops, Target Carriers, Turners

American Target Company
1346 South Jason Street
Denver, CO 80223

American Training Aids
750 Clemson Rd.
Columbia, SC 29206

Caswell Equipment Company, Inc.
1221 Marshall Street, NE
Minneapolis, MN 55413

Dentam Corporation
1346 South Jason Street
Denver, CO 80223

Dept. of the Army
Corps of Engineers
Construction Engineering Reseach Lab
P.O. Box 4005
Champaign, IL 61820
Phone: 1-800-USA-CERL

Detroit Bullet Trap Corporation
2233 North Palmer Drive
Schaumburg, IL 60172

Dixi-USA (Machine Tool) Corp.
1455 Veterans Highway
Hauppauge, NY 11787

MIL-HDBK-1027/3A

Polytronic-ABA, Inc.
P.O. Box 500
Pinellas Park, FL 34290

Range Lighting

The Illuminating Engineering Society
345 East 47th Street
New York, NY 10017

Verd-A-Ray Corporation
1120 Connecticut Ave., N.W.
Washington, DC 20036

Range Ventilation Consultants

ETC, Inc.
3513 Leith Lane
Louisville, KY 40218

Safety Curtains, Backsplatter Protectors

Linatex Corporation of America
P.O. Box 65
Stafford Springs, CT 06076

Sound Attenuation Material

Illbruck/USA
3800 Washington Avenue, North
Minneapolis, MN 55412

Laminations Corporation
2254 Harrison Road
Neenah, WI 54956

Dixi S.A./Usine 1
Rue de la Cote 35
CH-2400 Le Locle
Switzerland

MIL-HDBK-1027/3A

APPENDIX C: OUTDOOR SMALL ARMS RANGE CRITERIA CHECKLIST

1. The following checklist is intended for use as an aid during field evaluations of an existing range. It may be modified and/or adapted to meet site-specific conditions during a field evaluation.

Design criteria are referenced to paragraph numbers and figures in MIL-HDBK-1027/3A, Range Facilities and Miscellaneous Training Facilities Other Than Buildings. This is intended to provide a basic reference; other paragraphs and figures in MIL-HDBK-1027/3A may be applicable.

The form is self-explanatory except for the following points. "Description" means type of range, firing distances, fixed or moving targets, and similar descriptive information. "Known Interference" means a statement relating to encroachment, such as operation of adjoining range, waterborne traffic in nearby waterway, low-flying aircraft, or other. If none, insert "none."

OUTDOOR SMALL ARMS RANGE CRITERIA CHECKLIST

Location: _____ Project: _____
 Description: _____ Authorized Firing: _____ Most Powerful Weapon: _____
 Rifle Inspector: _____
 Pistol Known Interference: _____ Drawings Attached Yes No
 Other: _____ Date: _____
 Ammunition: _____ Sheet Number _____ of _____

No.	Physical Item	Features Basic Requirements	MIL-HDBK-1027/3A	Compliance w/Reqs.		Comments/Recommendations
				Yes	No N/A	
1	Surface Danger Zone	Under Navy Control	¶2.2.1; 2.4.1			
2	Impact Area Open Range and With Impact Berm	5 deg. Lft. & Rt. Limit of fire	Fig. 2, 2A, 2B			
	With Side Protection	50 yds. Lft. & Rt. Limit of fire	Fig. 2C			
3	Ricochet Area Open Range and With Impact Berm	5 deg. Lft. & Rt. impact area	Fig. 2, 2A, 2B			
	With Side Protection With Overhead Baffles	5 deg. Lft. & Rt. of 50 yd. of fire	Fig. 2C Fig. 2D			
	With Ground Baffles	50 yds. Lft. & Rt. by 300 yds.	Fig. 2E			
4	Secondary Danger Area	30 deg. & 100 m Lft. & Rt. of ricochet area	Fig. 2, 2A			
5	Parallel Ranges	Safety arc not closer than 50 yds. of target pits, or 8 ft. high min. wall or berm	¶2.3.1, Fig. 6			

Sheet Number _____ of _____

No.	Physical		Features Basic Requirements	MIL-HDBK-1027/3A	Compliance w/Reqs.		Comments/Recommendations
	Item	Requirements			Yes	No	
6	Target Line Emplacement bermis Spacing Carrier	Spacing same as firing line Protection of mechanisms Rifle=9 ft.; Pistol=5 ft. Full face of target visible from firing positions	Fig. 7,9 12.2.8, Fig. 5 12.3.4; 2.4.3 12.3.4.3; 2.4.3				
	Target Butts		12.3.5, Fig. A-3, A-4				
	Turning Targets	Usually pistol only	12.2.10, Fig. 9				
7	Firing Line Spacing Canopy Electronic scoring	9 ft. rifle, 5 ft. pistols 12 ft. forward firing line	Fig. 7,9 12.5.2 12.3.7.4				
8	Impact Berm Earth	Full width impact area Slope 1/1	12.3.7; 2.4.5 12.3.7.1, Fig. 8				
	Open Range:	5 ft. above top of target + 15 ft. earth or vertical baffle	12.3.7.2				
	Baffled Range:	5 ft. above highest point of impact + 15 ft. earth or vertical baffle	12.3.7.2				
	Bullet catch Eyebrow catch	If slope less than 1/1 When bullets are leaving range	12.3.7.3 12.3.7.3, Fig. A-5				
9	Side Protection	Earth berms, continuous walls, wing walls	12.5.5				

Sheet Number _____ of _____

No.	Physical Features		MIL-HDBK-1027/3A	Compliance		Comments/Recommendations
	Item	Basic Requirements		Yes	No	
10	Overhead Baffles Geometry	Minimize projectile leaving range	¶2.5.3 ¶2.5.1, Fig. 4			
	Materials	Appropriate to weapon and ammunition	¶2.5.8, Fig. A-6, A-7			
11	Ground Baffles	Normally pistol only	¶2.5.4			
12	Site Characteristics Grade	Between 1% & 2% side to side	¶2.2.4.2			
	Elevation	Firing/target - same elevation	¶2.2.4.2			
	Drainage	No impounded areas				
13	Range Floor	Clear of trees, free of rocks	¶2.2.4.2			
	Hard surface concrete	Fully baffled range	Fig. 3			
14	Landscaping Grass cover Walks	To prevent erosion	¶2.2.5 ¶2.2.5.1 ¶2.2.5.6			
15	Communications	On firing line, between firing line and target pits	¶2.2.11.1			
16	Safety Equipment Warning signs and flags	Danger firing in progress, approach roads, barriers	2.2.2; 2.2.3 ¶3.2, Appendix A			

Sheet Number _____ of _____.

No.	Physical Features		MIL-HDBK-1027/3A	Compliance w/Reqs.		Comments/Recommendations
	Item	Basic Requirements		Yes	No	
17	Support Facilities Control tower	Height to allow full view of danger zone, if surface danger area over water	¶3.3 ¶2.2.2			
	Access roads	Height to see target & personnel	¶2.9.2 ¶3.1.4			

MIL-HDBK-1027/3A

REFERENCES

FEDERAL/MILITARY SPECIFICATIONS, STANDARDS, BULLETINS, HANDBOOKS, AND NAVFAC GUIDE SPECIFICATIONS.

The following specifications, standards, bulletins, and handbooks form a part of this document to the extent specified herein. Unless otherwise indicated, copies are available from Commanding Officer, Naval Publications and Forms Center (NPFC), ATTENTION: NPODS, 5801 Tabor Avenue, Philadelphia, PA 19120.

SPECIFICATIONS

MILITARY

- | | |
|-----------------|---|
| MIL-A-12560G(1) | Armor Plate, Steel, Wrought, Homogeneous (For Use in Combat-Vehicles and for Ammunition Testing), 12 February 1985. |
| MIL-S-16216J(1) | Steel Plate, Alloy, Structural, High Yield Strength (HY-80 and HY-100), 16 August 1982. |

HANDBOOKS

- | | |
|-----------------|--|
| MIL-HDBK-1002/1 | Structural Engineering-General Requirements |
| MIL-HDBK-1004/1 | Preliminary Design Considerations |
| MIL-HDBK-1008A | Fire Protection for Facilities Engineering, Design, and Construction |
| MIL-HDBK-1013/1 | Physical Security of Fixed Land-based Facilities |
| MIL-HDBK-1025/6 | General Criteria for Waterfront Construction |
| MIL-HDBK-1190 | Facility Planning and Design Guide |

NAVY MANUALS, DRAWINGS, P-PUBLICATIONS, AND MAINTENANCE OPERATING MANUALS

Available from Commanding Officer, Naval Publications and Forms Center (NPFC), 5801 Tabor Avenue, Philadelphia, PA 19120-5099. To order these documents, Government agencies must use the Military Standard Requisitioning and Issue Procedure (MILSTRIP); the private sector must write to NPFC, ATTENTION: Cash Sales, Code 1051, 5801 Tabor Avenue, Philadelphia, PA 19120-5099.

- | | |
|---------|--|
| DM-1.01 | Basic Architectural Requirements and Design Considerations |
| DM-1.03 | Architectural Acoustics |
| DM-3.01 | Plumbing Systems |

MIL-HDBK-1027/3A

DM-3.03	Heating, Ventilating, Air Conditioning and Dehumidifying Systems
DM-3.10	Noise and Vibration Control for Mechanical Equipment
DM-5 Series	Civil Engineering
DM-5.03	Drainage Systems
DM-5.4	Pavements
DM-5.5	General Provisions and Geometric Design for Roads, Streets, Walks, and Open Storage Areas
DM-5.7	Water Supply Systems
DM-5.8	Pollution Control Systems
DM-5.12	Fencing, Gates, and Guard Towers
DM-7.02	Foundations and Earth Structures
DM-11.1	Tropical Engineering
DM-12.1	Electronic Facilities Engineering
P-80	Facility Planning Criteria for Navy and Marine Corps Shore Installations
P-457	Planning and Design of Outdoor Sports Facilities

NAVY DEPARTMENTAL INSTRUCTIONS: Available from Commanding Officer, Naval Publications and Forms Center, ATTENTION: Code 3015, 5801 Tabor Avenue, Philadelphia, PA 19120-5099.

OPNAVINST 3770.2G	Airspace Procedures Manual.
OPNAVINST 5530.13	Physical Security Instruction for Sensitive Conventional Arms, Ammunition and Explosives
NAVFACINST 6260.2	Reviews For Health Hazards During Facility Design Process
NAVFAC MO-100.1	Natural Resources Land Management

NAVSEA

OP-5 Vol. 1	Ammunition Ashore Handling, Stowing, and Shipping
-------------	---

MIL-HDBK-1027/3A

OTHER GOVERNMENT DOCUMENTS AND PUBLICATIONS.

The following Government documents and publications form a part of this document to the extent specified herein.

ARMY

AR 385-30 Safety Color Code Markings and Signs

(Unless otherwise indicated, copies are available from U. S. Army Adjutant General, Publications Center, 1655 Woodson Rd., St. Louis, MO 63114.)

FEDERAL AVIATION ADMINISTRATION (FAA)

Federal Aviation Act of 1958

(Unless otherwise indicated, copies are available from Federal Aviation Administration, 800 Independence Avenue S.W., Washington, D.C. 20590.)

MARINE CORPS

MCO P3570.1A Policies and Procedures for Firing Ammunition for Training, Target Practice, and Combat, 15 Oct 83, effective 15 Nov 83.

(Unless otherwise indicated, copies are available from Commandant Marine Corps, Code HQSP-2, Headquarters, USMC, Washington, DC 20380-0001.)

OCCUPATIONAL SAFETY AND HEALTH ADMINISTRATION (OSHA)

Department of Labor Handbook, CFR Title 29-1910.1025

(Unless otherwise indicated, copies are available from Occupational Safety and Health Administration, 1700 Constitution Ave, N.W., Washington, D.C. 20402.

NON-GOVERNMENT PUBLICATIONS.

The following publications form a part of this document to the extent specified herein. Unless otherwise specified, the issues of the documents which are DoD adopted are those listed in the Department of Defense Index of Specifications & Standards (DODISS).

AMERICAN CONFERENCE OF GOVERNMENTAL INDUSTRIAL HYGIENISTS

Industrial Ventilation Manual, 18th edition

(Unless otherwise indicated, copies are available from American Conference of Governmental Industrial Hygienists, Bldg. D-7, 6500 Glenway, Cincinnati, OH 45211-4438.)

MIL-HDBK-1027/3A

AMERICAN SOCIETY FOR TESTING AND MATERIALS (ASTM)

ASTM A36/A36M-87	Standard Specification for Structural Steel (DOD adopted)
ASTM A242/A242M-87	Standard Specification for High-Strength Low-Alloy Structural Steel (DOD adopted)
ASTM A441/A441M-85	Specification for High-Strength Low-Alloy Structural Manganese Vanadium Steel (DOD adopted)
ASTM A514/A514M-87	Specification for High-Yield-Strength, Quenched and Tempered Alloy Steel Plate, Suitable for Welding (DOD adopted)
ASTM A572/A572M-85	Standard Specification for High-Strength Low-Alloy Columbium-Vanadium Steels of Structural Quality (DOD adopted)
ASTM A607-85	Specification for Steel, Sheet and Strip, High-Strength, Low-Alloy, Columbium or Vanadium, or Both, Hot-Rolled and Cold-Rolled (DOD adopted)

(Unless otherwise indicated, copies are available from American Society for Testing and Materials (ASTM), 1916 Race Street, Philadelphia, PA 19103.)

CUSTODIAN
NAVY - YD

PREPARING ACTIVITY
NAVY - YD

PROJECT NO.
FACR-0261

STANDARDIZATION DOCUMENT IMPROVEMENT PROPOSAL

(See Instructions - Reverse Side)

1. DOCUMENT NUMBER MIL-HDBK-1027/3A		2. DOCUMENT TITLE Range Facilities and Miscellaneous Training Facilities	
3a. NAME OF SUBMITTING ORGANIZATION		4. TYPE OF ORGANIZATION (Mark one)	
b. ADDRESS (Street, City, State, ZIP Code)		<input type="checkbox"/> VENDOR	
		<input type="checkbox"/> USER	
		<input type="checkbox"/> MANUFACTURER	
		<input type="checkbox"/> OTHER (Specify): _____	
5. PROBLEM AREAS			
a. Paragraph Number and Wording:			
b. Recommended Wording:			
c. Reason/Rationale for Recommendation:			
6. REMARKS			
7a. NAME OF SUBMITTER (Last, First, MI) - Optional		b. WORK TELEPHONE NUMBER (Include Area Code) - Optional	
c. MAILING ADDRESS (Street, City, State, ZIP Code) - Optional		8. DATE OF SUBMISSION (YYMMDD)	

(TO DETACH THIS LINE, CUT ALONG THIS LINE.)

INSTRUCTIONS: In a continuing effort to make our standardization documents better, the DoD provides this form for use in submitting comments and suggestions for improvements. All users of military standardization documents are invited to provide suggestions. This form may be detached, folded along the lines indicated, taped along the loose edge (*DO NOT STAPLE*), and mailed. In block 5, be as specific as possible about particular problem areas such as wording which required interpretation, was too rigid, restrictive, loose, ambiguous, or was incompatible, and give proposed wording changes which would alleviate the problems. Enter in block 6 any remarks not related to a specific paragraph of the document. If block 7 is filled out, an acknowledgement will be mailed to you within 30 days to let you know that your comments were received and are being considered.

NOTE: This form may not be used to request copies of documents, nor to request waivers, deviations, or clarification of specification requirements on current contracts. Comments submitted on this form do not constitute or imply authorization to waive any portion of the referenced document(s) or to amend contractual requirements.

(Fold along this line)

(Fold along this line)

DEPARTMENT OF THE NAVY



NO POSTAGE
NECESSARY
IF MAILED
IN THE
UNITED STATES

OFFICIAL BUSINESS
PENALTY FOR PRIVATE USE \$300

BUSINESS REPLY MAIL
FIRST CLASS PERMIT NO. 12503 WASHINGTON D. C.

POSTAGE WILL BE PAID BY THE DEPARTMENT OF THE NAVY

Commanding Officer
Southern Division Code 04A3
Naval Facilities Engineering Command
P.O. Box 10068
Charleston, S.C. 29411-0068

