

INCH-POUND

MIL-HDBK-1027/1
15 MARCH 1991

MILITARY HANDBOOK

FIREFIGHTING SCHOOL FACILITIES



AMSC N/A

AREA FACR

DISTRIBUTION STATEMENT A. APPROVED FOR PUBLIC RELEASE: DISTRIBUTION IS UNLIMITED

MIL-HDBK-1027/1

ABSTRACT

This handbook provides basic design guidance developed from extensive reevaluation of facilities necessary to support new firefighting devices. It is intended for use by experienced architects and engineers. The contents cover the technical and environmental requirements of the structures which house them.

MIL-HDBK-1027/1

FOREWORD

This handbook has been developed from an evaluation of facilities in the shore establishment, from surveys of the availability of new materials and construction methods, and from selection of the best design practices of the Naval Facilities Engineering Command (NAVFACENGCOC), other Government agencies, and the private sector. This handbook was prepared using, to the maximum extent feasible, national professional society, association, and institute standards. Deviations from these criteria cannot be made without prior approval of NAVFACENGCOC HQ (Code 04).

Design cannot remain static any more than can the functions it serves or the technologies it uses. Accordingly, recommendations for improvement are encouraged and should be furnished to Commanding Officer, Atlantic Division, Naval Facilities Engineering Command (LANTNAVFACENGCOC), Code 04A4, Norfolk, VA 23511-6287; telephone (804) 444-9970.

THIS HANDBOOK SHALL NOT BE USED AS A REFERENCE DOCUMENT FOR PROCUREMENT OF FACILITIES CONSTRUCTION. IT IS TO BE USED IN THE PURCHASE OF FACILITIES ENGINEERING STUDIES AND DESIGN (FINAL PLANS, SPECIFICATIONS, AND COST ESTIMATES). DO NOT REFERENCE IT IN MILITARY OR FEDERAL SPECIFICATIONS OR OTHER PROCUREMENT DOCUMENTS.

MIL-HDBK-1027/1

TRAINING FACILITIES CRITERIA MANUALS

<u>Criteria Manual</u>	<u>Title</u>	<u>PA</u>
MIL-HDBK-1027/1	Firefighting School Facilities	LANTDIV
MIL-HDBK-1027/2	General Training Facilities (Proposed)	SOUTHDIV
MIL-HDBK-1027/3A	Range Facilities and Miscellaneous Training Facilities Other than Buildings	SOUTHDIV
MIL-HDBK-1027/4	Aviation Training Facilities (Proposed)	SOUTHDIV

MIL-HDBK-1027/1

FIREFIGHTING SCHOOL FACILITIES

CONTENTS

		<u>Page</u>
Section 1	INTRODUCTION	
1.1	Scope.....	1
1.2	Application	1
1.2.1	Types of Trainers.....	1
Section 2	DESIGN CRITERIA	
2.1	Site Development.....	2
2.1.1	Flooding Considerations.....	2
2.1.2	Prevailing Wind.....	2
2.1.3	Drainage.....	2
2.1.4	Circulation Patterns.....	2
2.1.5	Support Facilities.....	2
2.1.6	Security.....	2
2.1.7	Setbacks and Clearances.....	2
2.1.8	Pollution Permits.....	2
2.1.9	Contaminated Soil.....	2
2.1.10	Design for Accessibility of Physically Handicapped Personnel.....	3
2.1.11	Energy Conservation	3
2.1.12	Design Similarity.....	3
2.2	Utility Design.....	3
2.2.1	General.....	3
2.2.1.1	Service.....	3
2.2.1.2	Design for Simultaneous Operation.....	3
2.2.1.3	Freeze Protection and Snow.....	3
2.2.1.4	Breathing Air.....	4
2.2.1.5	Fire Department.....	4
2.2.1.6	Electromagnetic Interference (EMI).....	4
2.2.2	Equipment Outages	4
2.2.2.1	Standby.....	4
2.2.2.2	Emergency Power.....	5
2.2.2.3	Emergency Water.....	5
2.2.2.4	Lightning Protection	5
2.2.2.5	Lighting.....	5
2.2.3	Fuel.....	5
2.2.3.1	Propane.....	5
2.2.3.2	Natural Gas.....	15
2.2.3.3	Oil and Gasoline.....	15
2.2.4	Water.....	15
2.2.4.1	Potable Water.....	15
2.2.4.2	Water Storage.....	16
2.2.5	Wastewater.....	16
2.2.6	Electrical Power.....	17

MIL-HDBK-1027/1

		<u>Page</u>
2.3	Supporting Facilities.....	17
2.3.1	Utilities Building.....	17
2.3.2	Storage and Refill.....	18
2.4	Other Facilities.....	18
2.4.1	P-250 Demonstration.....	18
2.4.2	Wild Hose.....	19
2.4.3	Smoke House.....	19
2.4.4	Hose Drying Area.....	20
2.4.5	Maintenance Contractor Area.....	20
2.4.5.1	Room Provisions.....	20
2.5	Interfaces.....	20
2.5.1	General.....	20
2.5.2	Device Contractor.....	20
2.5.3	Construction Contractor.....	21
2.5.3.1	Electric.....	21
2.5.3.2	Data Terminal Cabinet (DTC).....	22
2.5.3.3	Fuel.....	22
2.5.3.4	Fireplace.....	22
2.5.3.5	APC Extinguishing Agent Simulation.....	22
2.6	Device.....	22
2.7	Gas Chamber.....	23
2.7.1	General.....	23
2.7.2	Training.....	23
2.7.3	Site Development.....	23
2.7.4	Architectural.....	23
2.7.4.1	Layout.....	24
2.7.4.2	Decontamination Station.....	24
2.7.4.3	Storage Locker.....	24
2.7.4.4	Collateral Equipment.....	24
2.7.5	Plumbing.....	24
2.7.6	Mechanical.....	25
2.7.7	Electrical.....	25
2.7.8	Tear Gas Characteristics.....	25
Section 3	TRAINING STRUCTURE	
3.1	Training Courses.....	27
3.2	General.....	27
3.2.1	Heat Protection.....	27
3.2.2	Personnel Spacing.....	28
3.2.3	Weather and Freeze Protection.....	28
3.2.4	Drainage.....	28
3.2.4.1	Drainage Piping Material.....	29
3.2.5	Escape Trunks.....	29
3.2.6	Consumables.....	29
3.2.7	Burner Rooms.....	29
3.2.8	Obstructions.....	29
3.2.9	Separation Chamber and Piping Traps.....	29

MIL-HDBK-1027/1

	<u>Page</u>
3.2.10	Fireplace Compartment Dimensions 30
3.3	Repair or Crash Lockers 30
3.4	Doors and Hatches 30
3.4.1	Watertight Doors 30
3.4.2	Hollow Metal Doors 31
3.4.3	Wire Mesh Doors 31
3.4.4	Automatic Closing (Ellison) Doors 31
3.4.5	Large Hatch 31
3.4.6	Small Hatch 31
3.5	Ladders 31
3.5.1	Inclined Ladders 31
3.5.2	Vertical Ladders 32
3.6	Lighting and Electrical 32
3.6.1	General Lighting 32
3.6.2	Special Compartment Lighting 32
3.6.3	120-Volt Alternating Current (Vac) Convenience Outlets 33
3.6.4	Electrical Interlocks in Crawl Space and Burner Rooms 33
3.6.5	Alarm for Loss of Electrical Power 35
3.7	Floors 35
3.7.1	Training Floor 35
3.7.2	Crawl Space Floor 35
3.7.3	Staging Floor 36
3.7.4	Maintenance Floor 37
3.7.5	Computer Floor 37
3.7.6	Grating Floors and Platforms 37
3.8	Walls 37
3.8.1	Wall System 37
3.8.2	Windows 38
3.8.3	Cool Down 38
3.9	Roofs and Ceilings 38
3.9.1	Training Compartment Ceilings 38
3.9.2	Staging Area Roofs 38
3.10	Instructor's Station and Electrical Space 39
3.10.1	Air Conditioned Space 39
3.10.2	Temperature and Relative Humidity 39
3.10.3	Fire Protection 39
3.10.4	Window Glass 39
3.10.5	Plugged Tap 39
3.11	Ventilation 39
3.11.1	General 39
3.11.2	Purge 40
3.11.3	Flushing 40
3.11.4	Combustion Air 40
3.11.5	Exhaust 40
3.11.6	Dilution Air 41
3.11.7	Equipment 41

MIL-HDBK-1027/1

	<u>Page</u>
3.11.7.1	Louvers..... 41
3.11.7.2	Dampers..... 42
3.11.7.3	Fan..... 43
3.11.8	Control..... 44
3.11.9	Preheat..... 45
3.11.10	Other Rooms..... 45
3.11.10.1	Burner and Electrical Rooms..... 45
3.11.10.2	Escape Trunks..... 46
3.11.11	Safety..... 46
3.11.11.1	Fuel Sensors..... 46
3.11.11.2	24-Hour Propane Alarm..... 46
3.11.11.3	Fan Interlock..... 46
3.11.11.4	Insulation or Shielding..... 46
3.12	21C12 and 21C12A Structures..... 47
3.12.1	General..... 47
3.12.2	Siting..... 47
3.12.3	Architectural..... 47
3.12.3.1	Layout..... 47
3.12.3.2	Fireplace Compartment..... 47
3.12.3.3	Crawl Space..... 48
3.12.3.4	Staging Areas..... 48
3.12.3.5	Burner Room..... 48
3.12.3.6	Bulk Storage..... 48
3.12.3.7	AFFF Fill Station..... 49
3.12.3.8	CO ₂ Extinguisher Fill Station..... 50
3.12.3.9	Repair Lockers..... 50
3.12.3.10	Ceilings..... 50
3.12.3.11	Doors..... 50
3.12.3.12	Fireplaces..... 50
3.12.3.13	Instructor's Station..... 51
3.12.3.14	Miscellaneous..... 51
3.12.4	Mechanical..... 51
3.12.4.1	Use Rate..... 51
3.12.4.2	Firefighting Agents..... 51
3.12.4.3	Ventilation for 21C12 and 21C12A Structures..... 54
3.12.4.4	Air Conditioning and Heating..... 55
3.12.4.5	Cooling Spray..... 56
3.12.4.6	Breathing Air..... 56
3.12.5	Electrical..... 57
3.12.5.1	Power..... 57
3.12.5.2	Lighting..... 57
3.12.6	Propane Alarm System..... 57
3.12.6.1	Central Control Panel..... 57
3.12.6.2	Audible Alarms..... 58
3.12.6.3	Propane Warning Signs..... 58
3.12.7	Manual Pull Stations..... 59
3.12.8	Auxiliary Control Stations..... 59

MIL-HDBK-1027/1

	<u>Page</u>
3.12.9	Intercom System..... 59
3.13	19F1A and 19F1B Structures..... 59
3.13.1	General..... 59
3.13.2	Architectural..... 59
3.13.2.1	Layout..... 59
3.13.2.2	Ceilings..... 60
3.13.2.3	Doors and Hatches..... 60
3.13.2.4	Fireplaces..... 60
3.13.2.5	Enclosures..... 60
3.13.2.6	Instructor's Station..... 62
3.13.2.7	Miscellaneous..... 63
3.13.3	Mechanical..... 63
3.13.3.1	Use Rate..... 63
3.13.3.2	Firefighting Agents..... 63
3.13.3.3	Ventilation..... 64
3.13.3.4	Air Conditioning..... 64
3.13.4	Electrical..... 64
3.14	19F3 and 19F3B Structures..... 67
3.14.1	General..... 67
3.14.2	Architectural..... 68
3.14.2.1	Bilge Fire Building (19F3 and 19F3B)..... 68
3.14.2.2	Galley/Berthing Fire Building..... 68
3.14.2.3	Pit Fire Building..... 69
3.14.2.4	Doors..... 69
3.14.2.5	Fireplaces..... 69
3.14.2.6	Instructor's Station..... 69
3.14.3	Mechanical..... 69
3.14.3.1	Use Rates..... 69
3.14.3.2	Ventilation..... 71
3.14.3.3	Air Conditioning..... 71
3.14.4	Electrical..... 75
3.15	19F3A and 19F3C Structures..... 75
3.15.1	General..... 75
3.15.2	Architectural..... 76
3.15.2.1	Layout..... 76
3.15.2.2	Doors and Hatches..... 77
3.15.2.3	Fireplaces..... 77
3.15.2.4	Instructor's Station..... 77
3.15.2.5	Miscellaneous..... 77
3.15.3	Mechanical..... 77
3.15.3.1	Use Rate..... 77
3.15.3.2	Firefighting Agents..... 81
3.15.3.3	Ventilation..... 82
3.15.3.4	Air Conditioning..... 82
3.15.4	Electrical..... 82
3.15.4.1	Power..... 82
3.15.4.2	Lighting..... 82

MIL-HDBK-1027/1

	<u>Page</u>
3.16	19F4 and 19F4A Structures..... 83
3.16.1	General..... 83
3.16.2	Architectural..... 83
3.16.2.1	Layout..... 83
3.16.2.2	Foam Deck..... 84
3.16.2.3	Crash Lockers..... 85
3.16.2.4	Instructor's Station..... 85
3.16.2.5	Doors..... 85
3.16.2.6	Structural Features..... 85
3.16.2.7	Miscellaneous..... 86
3.16.3	Mechanical..... 86
3.16.3.1	Use Rate..... 86
3.16.3.2	Firefighting Agents..... 89
3.16.3.3	Ventilation..... 89
3.16.3.4	Air Conditioning..... 89
3.16.3.5	Miscellaneous..... 90
3.16.3.6	Foam Proportioning..... 90
3.16.4	Electrical..... 90
3.16.4.1	Power..... 90
3.16.4.2	Lighting..... 91
3.17	19F5 and 19F5A Structures..... 91
3.17.1	General..... 91
3.17.2	Architectural..... 91
3.17.2.1	Layout..... 91
3.17.2.2	Ceilings..... 91
3.17.2.3	Doors..... 91
3.17.2.4	Fireplaces..... 92
3.17.2.5	Instructor's Station..... 92
3.17.2.6	Egress Chamber..... 92
3.17.2.7	Miscellaneous..... 93
3.17.3	Mechanical..... 93
3.17.3.1	Use Rate..... 93
3.17.3.2	Firefighting Agents..... 93
3.17.3.3	Ventilation..... 96
3.17.3.4	Air Conditioning..... 96
3.17.4	Electrical..... 96
3.17.4.1	Power..... 96
3.17.4.2	Lighting..... 96
3.18	Seawolf Structure..... 97
3.18.1	General..... 97
3.18.2	Siting..... 97
3.18.3	Architectural..... 97
3.18.3.1	Layout..... 98
3.18.3.2	Fireplace Compartment..... 98
3.18.3.3	Staging Areas..... 98
3.18.3.4	Bulk Storage..... 98
3.18.3.5	Architectural Requirements..... 98

MIL-HDBK-1027/1

		<u>Page</u>
3.18.4	Mechanical.....	98
3.18.4.1	Use Rate.....	98
3.18.4.2	Propane, Agent, and Extinguisher Usage Per Class.....	99
3.18.4.3	Firefighting Agents.....	99
3.18.4.4	AFFF Hose System.....	100
3.18.4.5	Mechanical and Electrical Requirements.....	100
Section 4	AGENTS AND APPARATUS	
4.1	General.....	101
4.2	Aqueous Film-Forming Foam (AFFF).....	101
4.2.1	Substitute.....	101
4.2.2	Handling System.....	102
4.2.3	Portable AFFF Fire Extinguishers	103
4.3	Potassium Bicarbonate.....	103
4.4	Carbon Dioxide (CO ₂).....	104
4.5	Halon.....	105
4.6	Aqueous Potassium Carbonate (APC).....	105
4.7	Nozzles.....	105
4.8	Oxygen Breathing Apparatus (OBA).....	105
4.9	Hose Stations.....	105
4.9.1	Hose Station 1 (HS1).....	105
4.9.2	Hose Station 2 (HS2).....	107
4.9.3	Foam Station (FS).....	107
4.9.4	Foam Reel (FR).....	108
4.9.5	Stand Pipe (SP).....	108
4.9.6	Submarine Hose Station 1 (SHS1).....	108
4.9.7	Submarine Hose Station 2 (SHS2).....	108
4.9.8	Submarine Hose Station 3 (SHS3).....	109
4.9.9	Combined Submarine Hose Station (CSHS).....	109
4.9.10	PKP Fire Extinguisher (PFE).....	109
4.9.11	Twin Agent Reels (TAR).....	109
4.9.12	Submarine Hose Station 4 (SHS4).....	109
4.9.13	Submarine Hose Station 5 (SHS5).....	110
Section 5	PROTECTION OF THE ENVIRONMENT	
5.1	Permits.....	111
5.2	Air.....	111
5.2.1	PKP.....	111
5.2.2	Artificial Smoke.....	111
5.3	Wastewater.....	112
5.3.1	General.....	112
5.3.2	Separation Chamber.....	122
5.3.3	Pretreatment.....	122
5.3.4	Recovery.....	124

MIL-HDBK-1027/1

Page

APPENDICES

Appendix A	General	126
B	19F1A and 19F1B Structures.....	165
C	19F3 and 19F3B Structures.....	171
D	19F3A and 19F3C Structures.....	179
E	19F4 and 19F4A Structures.....	184
F	19F5 and 19F5A Structures.....	193
G	21C12 and 21C12A Structures.....	196
H	Gas Chamber.....	229
I	Carbon Dioxide (CO ₂).....	232
J	Propane	240

TABLES

Table 1	Main Ventilation Air for Fireplace Compartment of 21C12 and 21C12A Structures.....	44
2	21C12 and 21C12A Structures.....	52
3	Dimensions of Burn Areas for 19F1A and 19F1B Structures Figures.....	61
4	19F1A and 19F1B Structures.....	65
5	19F1A and 19F1B Ventilation Air.....	67
6	Dimensions for 19F3 and 19F3B Structures Fireplace Locations.....	70
7	19F3 and 19F3B Structures.....	72
8	19F3 and 19F3B Ventilation Air.....	75
9	Dimensions for 19F3A and 19F3C Structures Fireplaces.....	78
10	19F3A and 19F3C Structures.....	79
11	19F3A and 19F3C Ventilation Air.....	82
12	19F4 and 19F4A Structures.....	87
13	19F5 and 19F5A Structures.....	94
14	19F5 and 19F5A Ventilation Air.....	97
15	Total Utilities for Seawolf Structure.....	99
16	Typical Air Emissions Requirements.....	112
17	Wastewater Characteristics.....	113
18	Wastewater Surcharge Limits.....	121

REFEREENCES.....	253
------------------	-----

MIL-HDBK-1027/1

Section 1: INTRODUCTION

1.1 Scope. This military handbook prescribes the design criteria necessary to support new firefighting training devices and to outline the technical and environmental requirements of the structures which house them.

1.2 Application. The training facilities covered by this handbook as identified by the devices contained within are as follows:

- a) 19F1A and 19F1B - Advanced Shipboard Firefighting Trainers
- b) 19F3 and 19F3B - Basic Shipboard Firefighting Trainers, which consist of four training structures:
 - (1) B1 - Engine Room - Bilge Fire Trainer
 - (2) B2 - Galley/Berthing Fire Trainer
 - (3) B3 - Pit Fire Trainer
 - (4) B4 - Pit Fire Trainer
- c) 19F3A and 19F3C - Combined Basic/Advanced Shipboard Firefighting Trainers, which consist of a 19F1A portion and 19F3-B3 trainers
- d) 19F4 and 19F4A - Basic Shipboard Aircraft Firefighting Trainers
- e) 19F5 and 19F5A - Basic Recruit Shipboard Firefighting Trainers
- f) 21C12 and 21C12A - Submarine Firefighting Trainers
- g) Gas Chamber - Chemical Warfare Trainer
- h) Seawolf

1.2.1 Types of Trainers. There are two types of trainers: warm and cold weather designs. The cold weather design is applicable to all sites in climates where the annual heating degree days are 2,000 or greater. The warm weather design is applicable to all sites in climates where the annual heating degree days are less than 2,000.

MIL-HDBK-1027/1

Section 2: DESIGN CRITERIA

2.1 Site Development

2.1.1 Flooding Considerations. When planning the site for a new 21C12 and 19F series facility, the finished floor area of the crawl space shall be high enough to preclude flooding during a 100-year storm. The training device equipment that will be installed in the crawl space is expensive and would be destroyed if the crawl space were flooded.

2.1.2 Prevailing Wind. The prevailing wind direction shall be one of the first considerations in selecting a site. The heat and products of combustion may be objectionable to adjacent buildings located downwind. The prevailing wind direction shall be shown on the drawings.

2.1.3 Drainage. Rainwater shall be channeled away from device structures because the water that enters the structure must be first treated and then disposed of in the sanitary sewer. Since firefighting agents are collected in the structures, surface runoff can be disposed of in the storm system without treatment.

2.1.4 Circulation Patterns. The site layout shall be designed to allow for personnel circulation patterns between each of the various support facilities and trainers.

2.1.5 Support Facilities. There are various support facilities that must be provided with the 19F and 21C12 series trainers. Classroom space, restrooms, showers, and changing area shall be provided to support the students and instructors. In addition, a maintenance area, utilities space, storage area, and wastewater treatment system shall be provided. The initial planning shall be designed to allow for bulk deliveries of fuel and dry storage.

2.1.6 Security. The grounds around a firefighting school shall be fenced to restrict entry of unauthorized personnel. The fuel and CO₂ storage areas shall each be fenced and exterior doors to firefighting school facilities shall be of the lockable type.

2.1.7 Setbacks and Clearances. The exterior of firefighting structures shall have a clearance of 50 feet (15.2 m) away from any obstruction, trees, building, structure, etc., to allow free access of natural ventilation air to the crawl space, and to allow access for snow and ice removal.

2.1.8 Pollution Permits. The preliminary design should include the initiation of air and water pollution permit applications.

2.1.9 Contaminated Soil. As a result of several firefighting trainer sites having contaminated soil, evaluate selected firefighting trainer sites for soil and groundwater contamination during the planning stage of the project. Permits may be required for the site cleanup.

MIL-HDBK-1027/1

2.1.10 Design for Accessibility of Physically Handicapped Personnel.

Provisions for physically handicapped personnel are not required in firefighting training facilities. The firefighting trainers are required to be designed for able-bodied naval personnel.

2.1.11 Energy Conservation. Normal building energy conservation measures are not a consideration in the firefighting facilities because of the facilities application, i.e., because heat is generated by the fires, energy conservation measures are not feasible. Energy studies are not required to be performed for firefighting trainers because the trainers are the same as trainers at other locations, and each trainer has the same mechanical and electrical systems. The one area of the firefighting facilities that will have conditioned air is the instructor station and the electrical room, which shall be designed to conserve energy in compliance with the latest techniques and applicable standards. Refer also to MIL-HDBK-1190, Facility Planning and Design Guide.

2.1.12 Design Similarity. Firefighting training structures shall be designed and constructed the same from site to site (i.e., firefighting training structures shall have the same internal dimensions, internal arrangements, similar functions, similar equipment, etc.). Design similarity is required to ensure that all naval personnel are exposed to similar training environments.

2.2 Utility Design

2.2.1 General

2.2.1.1 Service. The various services, water, fuel, 100 percent foam (surrogate) concentrate, and, possibly, compressed air shall be routed to each training structure by underground pipe. Each service shall include a manual shutoff valve for maintenance purposes. The valves to a given structure shall be grouped together in a valve pit with a cover small and light enough to be lifted by two men. No cover shall weigh more than 125 lb (56.6 kg) and each cover should have lifting handles. The propane valve shall be in a separate pit.

2.2.1.2 Design for Simultaneous Operation. The utilities for the firefighting training school shall be designed and sized to allow for training structures to operate simultaneously.

2.2.1.3 Freeze Protection and Snow. Firefighting facilities shall be protected against freeze damage. Because the training structures are not usually heated, interior and exterior water-based utilities located above ground shall be protected. Large valve pits with many valves shall also include protection for freezable utilities. Refer also to paragraphs 3.2.3 and 3.11.8 for additional requirements. Methods of freeze protection include drain-down, heat tracing, and air purge. The following criteria shall apply to this handbook:

MIL-HDBK-1027/1

a) When a drain-down system employs some method of automatically sensing ambient temperature and controlling a valve, install a manual valve in parallel with the automatic valve. The manual valve will provide an added measure of protection.

b) Freeze protection shall be provided at any location where there is the possibility of freezing temperatures. Sites as far south as Mayport, Florida, shall have freeze protection.

c) In those locations subjected to regular snow accumulations, ensure that the design will not impede the operation of exterior equipment. Design facilities to accommodate snow removal procedures.

d) Since the foam stations and foam reels cannot be adequately drained they shall be freeze-protected by a removable, insulated and electrically heated cover. The cover shall be completely removable so that during training the hose stations maintain a shipboard appearance.

2.2.1.4 Breathing Air. The quality standard for compressed air to be used for breathing air is Federal Specification (Fed. Spec.) BB-A-1034, Compressed Air, Breathing. Breathing air is not a requirement in surface fleet training facilities; however, it is a requirement for submarine fleet trainers. Refer to paragraph 3.12.4.6 for requirements. Breathing air for instructors by the use of personal "SCOTPAK" units is not covered by this handbook.

2.2.1.5 Fire Department. Training facilities are designed on the basis that experienced instructors with adequate fire control equipment will be present at all times that training is being conducted. The fire suppression capability will be supplemented by a municipal or military fire department whenever possible, with fire department notification provided by properly spaced exterior fire alarm boxes, fire telephones, or other approved means. Fire hydrants shall be provided at each firefighting school site in accordance with the National Fire Protection Association (NFPA) 24, Installation of Private Fire Service Mains and Their Appurtenances.

2.2.1.6 Electromagnetic Interference (EMI). Firefighting project sites shall be tested for EMI to determine required EMI protection for trainers. EMI testing shall be accomplished by the Naval Training Systems Center (NTSC) during preliminary design to determine cost impact. If NTSC test results indicate EMI shielding is required, NTSC shall determine if the device equipment can be shielded. If device EMI shields are determined to be inadequate, then NTSC shall notify the Engineering Field Division (EFD), NAVFACENGCOM, and LANTNAVFACENGCOM of facility EMI shielding requirements.

2.2.2 Equipment Outages

2.2.2.1 Standby. There is no requirement for standby equipment in excess of full design capacity for the systems supporting a firefighting training facility. Critical support systems, those whose downtime would affect a large

MIL-HDBK-1027/1

portion of the training, should be designed with parts totaling full capacity, i.e., two 50-percent fans or two 50-percent pumps. Then while a piece of equipment is not operating and being repaired, the second piece of equipment can be carrying 50 percent of the load. In all cases, critical equipment should be designed to provide as much reliability and maintainability as possible.

2.2.2.2 Emergency Power. Emergency power is generally not a requirement for firefighting facilities. The fuel and CO₂ systems are required to be failsafe, shutting off fuel and CO₂ when electrical power is lost. Without a continuous source of fuel, there can be no fire, because there is no combustible material inside a training structure. For this reason the propane entry station consisting of the "block and vent" (Appendix J, Figure J-2) shall be located outside of the training structure.

The availability of electricity at most training facilities is reliable enough that periodic outages will not adversely affect training. In the event of electrical power outage at a trainer, provide a battery backup annunciation and alarm at the 24-hour duty desk and at the instructor's station. Capability to silence the alarm shall be provided at both locations.

2.2.2.3 Emergency Water. Emergency water shall be water supplied under sufficient pressure to fight fires without the use of electrical energy. Water flow tests should be performed to determine the adequacy of the water supply system. A separate emergency water system is not necessary for the 19F series trainers for the same reasons stated above under emergency power. The Navy's portable gasoline powered P-250 pumps and the Municipal Fire Department are available for non-trainer structure fires.

2.2.2.4 Lightning Protection. As a minimum, the requirements of NFPA 78, Lightning Protection Code, should be followed. Lightning protection is not required for the propane tanks.

2.2.2.5 Lighting. The fenced-in grounds and parking area around the firefighting facility shall be lighted to provide general security.

2.2.3 Fuel

2.2.3.1 Propane. Propane shall be the fuel for the 19F and 21C12 series trainers. It has a standard and reliable chemical composition as opposed to natural gas which is a blend of chemicals. Propane gives the desirable flame characteristics and has been tested for environmental acceptability in the training situation. Complete stoichiometric burning of propane requires 23 cubic feet (ft³) (0.64 cubic meters (m³)) of air for each cubic foot of fuel. The following criteria is provided pertaining to propane as outlined in NFPA 58, Storage and Handling of Liquefied Petroleum Gases:

a) Properties and characteristics of liquified petroleum (LP) gases. Propane has certain properties and characteristics which must be understood by the persons handling and processing these products.

MIL-HDBK-1027/1

(1) They are normally gases but are changed to liquid state by the application of moderate pressure. At atmospheric pressure commercial propane boils at minus 44 degrees F. It is evident that at normal atmospheric temperatures and pressures, propane will be in a gaseous form. Propane in liquid state and open to the atmosphere will evaporate (not boil) although the atmospheric temperature may be below its boiling point.

(2) LP-gases contain no toxic components such as carbon monoxide. However, the vapors should not be inhaled as serious accidents could occur from ignition of gases contained in the lungs.

(3) LP-gases are heavier than air. With air equal to 1.0, the specific gravity of propane is 1.52. LP-gas will, therefore, collect in low places but will eventually diffuse into the atmosphere.

(4) The explosive range of propane-air mixture is lower and narrower than with other fuel gases and is 2.15 (lower explosive limit) to 9.6 (higher explosive limit) percent in air. The lower explosive limit is the limit at which combustion of propane can be sustained. The higher explosive limit is the limit at which the combustion of propane cannot be sustained.

(5) In accordance with requirements of NFPA 58, LP-gases are effectively odorized to positively indicate presence of gas down to concentration in air of not over one-fifth the lower explosive limit.

(6) The pressure exerted by propane gas in a container is entirely dependent upon the temperature of the contents. Excessive pressure may be relieved by discharging gas from above the liquid thus reducing the temperature of the liquid or by application of a cooling agent to the outside of the container. In the interest of safety, it is preferable to reduce the temperature of the liquid rather than permit the escape of high pressure gas with resultant potential hazard.

b) Propane data as listed in NFPA 58:

91,502 British thermal unit (Btu) Btu/gal (96,532.5 kJ/L)
 2,488 Btu/ft³ (2,637.5 kJ/m³)
 36.38 ft³/gal (1.02 m³/L)

Vapor pressure in psig at:

70 degrees F	127
100 degrees F	196
130 degrees F	287

Specific gravity of liquid at 60 degrees F	0.504
Initial boiling point at 14.7 psig, degrees F	-44

MIL-HDBK-1027/1

Flammability limit, percent of propane gas in air:

Lower	2.15
Upper	9.60

c) The design of the fuel system shall be in accordance with NFPA 54, National Fuel Gas Code and NFPA 58 and NAVFAC Design Manual DM-22, Petroleum Fuel Facilities. NFPA 58 covers the LP-gas system including the container, the vaporizer, the unloading station, and tank appurtenances up to the outlet of the first stage regulator. NFPA 54 covers the system from the tank or vaporizer regulator outlet including the piping, second stage regulator(s), appliances, and appliance venting, where the propane gas pressure is less than 20 psig at the regulator discharge.

d) Fuel should be stored in a single location which provides easy access for tank trucks. This is to facilitate inventory taking, reduce installation costs, and increase safety. A minimum of two tanks shall be used to store the fuel. This allows for tank maintenance without interruption to the training. The total storage should equal 30 days' consumption. A full storage tank shall be designed to contain 80 percent liquid equivalent to 30 days storage and 20 percent vapor. The vapor space allows for thermal expansion and must never be used for liquid storage. The storage area should be fenced to restrict pedestrian and vehicular traffic. The fence shall have a main entrance gate and a second gate on the opposite fence from such gate for emergency exit. The fence area shall have anti-vehicle barricade posts to protect tanks from an accidental collisions from vehicles or trucks. In accordance with NFPA 58, the storage area shall not have walls, barricades, curbed areas, etc., which would prevent access and lateral ventilation from flushing the area. The tanks shall be provided in accordance with the American Society of Mechanical Engineers (ASME), Boiler and Pressure Vessel Code, Section VIII, unfired pressure with a minimum working pressure of 300 psig. The tank foundations shall be proper for the soil bearing conditions and the weight of the tank plus its full weight of water because of the future hydrostatic testing of each tank. The tank exterior shells shall be coated with proper corrosion protective material where the tank shell rests on the foundation. This may be accomplished with a properly saturated pad. The tank shall be adequately grounded.

e) The tank valves and other appurtenances shall be listed and approved for LP-gas use by Underwriters Laboratories, Inc. (UL), Factory Mutual Research Corporation (FM), or other qualified testing facility. The tank pressure relief valves shall be in accordance with the specifications of UL or ASME. The vent outlet from such valves must be a minimum of 7 feet in height and must discharge vertically upward. The discharge vents shall be equipped with a loose rain cap so that it will not restrict the flow of propane vapor through such vent. The rain cap or end of the vent shall be installed to direct the discharge vertically upward only. It is preferable to install the pressure relief valves on a multiport manifold so that one valve at a time can be shut off for repair or replacement while the tank is properly protected by the remaining valve or valves which are still in service and cannot be shut off,

MIL-HDBK-1027/1

thus, ensuring full required relieving capacity. The vertical discharge of propane vapor 7 feet above the top of the container assists in dispersing propane in a general safe manner.

f) Storage tank liquid and vapor operating connections are to be equipped with internal valves. These internal valves function as a primary shutoff valve and have built-in excess flow protection. The valves are to be operated manually at the installed location, or from a remote location via pneumatic actuator. Provide a fusible plug at the valve location to close the valve in the event of fire.

g) The water drain discharge opening of the pressure relief valves must be equipped with a diverter to deflect any product flow when the valve operates away from impingement on the tank or an adjoining tank. This is necessary to prevent a hot spot and a possible tank shell failure if such discharge would become ignited.

h) Each connection to the storage tank must be equipped with an excess flow valve or a backflow check valve as required in NFPA 58 except for the pressure relief valve and openings of 58 drill size or smaller. The container shall also be equipped with a pressure gauge.

i) Liquid piping between shutoff points shall be equipped with a hydrostatic pressure relief valve to relieve the pressure caused by an increase in the liquid temperature resulting in an increase in pressure when the shutoff valves are in a closed position.

j) Accuracy in filling the tanks is important because of the expansion of the liquid as its temperature rises. The amount of propane that can be placed in a tank over 1,200 gallons water capacity as shown in Table 4-5.2.1 of NFPA 58 is 45 percent of the water weight capacity of the container. Then Table 4-5.2.3(b) shows that at 60 degrees F temperature the container can be filled to 88 percent. It is, thus, important to have accurate gauging devices. Such tanks generally have a variable gauge for general inventory control. The gauging devices are generally a float magnetic gauge with an indicator dial to show the percentage full of the contents at different temperatures; however, the gauging devices are not accurate enough to use them for maximum fill control because the float arm may become bent or other malfunction may occur that throws off the accuracy. As a result, a fixed liquid level gauge is required. This is a tube into the tank with the tube length made to extend down to the proper liquid level of 88 percent. There is a small valve with a restricted opening at the outer end. On filling of the container, the operator opens this valve and vapor will flow out during loading until the liquid reaches the bottom of the tube where a white cloud will appear at the outlet valve. This is not liquid propane but rather it is a water vapor cloud which is created when liquid propane expands to vapor and resulting refrigeration condenses the moisture in the air and creates the white cloud as fog. When this occurs, the operator must immediately shut off the flow of propane into the container and then shut off the gauge valve. Generally, at

MIL-HDBK-1027/1

firefighting schools, transport trucks will be used.

k) Propane will be delivered to the containers by transport truck or, in some cases, by tank car. Generally at firefighting schools, truck transport will be used. Truck transports are generally 8,000 to 11,000 gallon capacity. Usually, such transports are equipped with an unloading pump. In such cases, the unloading hose is connected to the storage unloading station liquid line for unloading. The vapor return hose is also connected to the storage tank vapor line. This connection assists in the liquid transfer as it prevents a buildup of vapor pressure in the receiving tank. The transport might be equipped with a vapor compressor instead of a pump to use for off-loading. Off-loading involves vapor being drawn off the storage tank and discharged into the transport tank which creates a higher pressure differential in the transport tank and thus forces the liquid to flow into the storage tank. When the liquid has been off-loaded from the transport to the storage, there will be some residual propane vapor in the transport. The vapor is recovered by switching the compressor valving so that it will then draw vapor from the transport and discharge it into the storage tank. This vapor piping to the storage tank should discharge into the liquid of the tank and not into the vapor space. This assists in condensing the vapor to liquid and thus speeds up the transfer. The recovery of the vapor results in an economic benefit.

l) Propane or water may be delivered to the storage by tank cars. In such cases, a proper tank car unloading facility must be installed. The facility should be a platform facility adjacent to the tank car unloading location. The facility should be equipped with liquid and vapor pipe lines and a hose connection at the platform. The hose connection should be of proper length to properly reach the tank car valve dome. There will be two liquid hoses so that a connection can be made to both liquid eduction valves on the tank car. These will be connected to the platform liquid piping at a three-way fitting. At the hose connection to this fitting, a backflow check valve shall be installed at each hose connection to prevent backflow into the tank car. The tank car liquid eduction and the vapor openings on the manhole cover plate are equipped with excess flow valves on the underside of the manhole cover. Hose connections are also equipped with shutoff valves in the protective dome. A pressure relief valve is installed in the center of the protective dome with an opening in the dome cover above the relief valve. The tank car is equipped with a sampling tube extending down from the manhole cover to the sump at the tank bottom so that a sample of the propane or water may be drawn off. There is also a thermometer well extending into the car tank. The thermometer well have an antifreeze solution in it to a height of about 12 inches to provide conductivity of propane liquid temperature to the thermometer when it is inserted in the well.

m) The transport trucks or tank cars should always have the wheels blocked by chock blocks to prevent movement while parked and especially while unloading. The transport truck or tank car unloading point must be equipped with an emergency shutoff valve to prevent a discharge from the storage tank(s) in case of a pullaway or break of the unloading hose or other equipment. Refer

MIL-HDBK-1027/1

to NFPA 58. The emergency shutoff valve shall be installed in the fixed piping between the tank and a substantial bulkhead with hose or swivel-type piping connections on the opposite side of the bulkhead from the emergency shutoff valve.

n) The bulkhead must be substantial and can be of concrete or equivalent. The piping must be fully anchored to the bulkhead not just by inserting the pipe through a sleeve.

o) Emergency shutoff shall be provided with three modes of operation: manually; remote control; and thermally. A preferable installation can be made which provides both thermal and remote control. The installation entails the running of plastic tubing to strategic points in or near the storage and unloading points pressurized with air, carbon dioxide (CO₂), etc., so that the pressure holds the valve open. Then if there is a fire, the plastic will melt, thus, enabling the valve to be closed. Install the plastic tubing so that it will be activated at all potential points of a flame. Install the tubing at a point where the emergency valve will be activated if there is a flame downstream beyond the bulkhead. For remote control, there may be a snap action release valve at several strategic locations in the tubing so that activation of valves releases the pressure and closes the emergency shutoff valve. The plastic tubing must be tied to the unloading hose so that a pullaway of the hose will break the tubing. In this way, a pullaway of the hose will activate the emergency shutoff valve and close the discharge from the tank storage. The excess flow valves in the transport piping should stop the flow from its tank. If it is a pullaway break, the transport tank valves should always have been closed before moving the vehicle.

p) After unloading the liquid from either a transport truck or a tank car, bleed the liquid propane from the connection after shutting off the valve at both the hose end and at the unloading piping. Many accidents have occurred because such bleeding has not been done. There shall be a bleed attachment built into the unloading equipment for this purpose. If the attachment is not provided then bleeding can be done by only partially disconnecting the hose, thus, creating some additional hazards.

q) Normally vapors for use will be drawn off of the container from the vapor space above the liquid. Propane boils from a liquid to a vapor at a liquid temperature of minus 44 degrees F or above and thus replaces the vapor being used. However, this evaporation creates heavy refrigeration which cools down the temperature of the liquid. If the draw is heavy enough it will result in insufficient vaporization thus requiring the use of a vaporizer to convert the liquid to vapor.

r) There are two basic types of vaporizers. One is the indirect type which is heated by a heating unit remote from the vaporizer. The indirect type shall furnish heat by steam, hot water, or other heating medium. The other is a direct-fired type. The standards for vaporizers is detailed in NFPA 58. Many times a pump is necessary to provide the necessary flow from the storage tank to

MIL-HDBK-1027/1

the vaporizer because if the vapor pressure in the storage tank gets low, the proper quantity of liquid will not flow to the vaporizer, thus the need for the liquid pump. The installation shall be in accordance with NFPA 58 and shall have the electrical equipment in accordance with NFPA 70, National Electrical Code. Waterbath and indirect-fired vaporizers are both acceptable for use at firefighting training facilities. An indirect-fired vaporizer shall be used when there is a sufficient sized central steam or high temperature hot water heating plant or system available. In this case, the indirect-fired vaporizer would be less expensive than the waterbath vaporizer. A waterbath vaporizer shall be used when there is no central heating plant or system available. In this case, the waterbath vaporizer would be less expensive than an indirect-fired vaporizer and a new heating plant. No direct-fired vaporizers other than the waterbath type are to be used.

s) When using indirect-fired vaporizers, NFPA 58 applies. FM Loss Prevention Data, Section 7-55/12-28, Liquified Petroleum Gas shall apply. In addition, the waterbath vaporizer installation and design shall be in accordance with the following:

- (1) Waterbath vaporizers shall be FM approved.
- (2) Waterbath vaporizers shall be located to maintain the space clearances as required by FM.
- (3) Emergency shutoff valves shall be provided with fusible links. The following emergency shutoff valves shall be provided in accordance with NFPA 58 and FM Loss Prevention Data:
 - (a) Liquid propane supply from the truck unloading station to the storage tank.
 - (b) Liquid propane supply from the storage tank to the vaporizer.
 - (c) Gas propane supply from the vaporizer.

Regardless of which type of propane vaporizer is used, the truck unloading station shall be located 75 feet minimum from the tank and vaporizer. Refer to Appendix J, Figure J-1.

t) Indirect-fired vaporizers can be located indoors in specially designed vaporizer rooms. See NFPA 58 for requirements. If a vaporizer room is provided then a separate propane alarm detection system shall be provided for the room. This alarm detection system shall provide an alarm (sound and flashing warning sign) in the instructor's station at the 24-hour duty desk, and locally at the vaporizer room entrance. A 24-hour battery backup shall be provided.

In addition to the alarm detection system, for propane vaporizers

MIL-HDBK-1027/1

installed indoors, provide the following safety features:

(1) An explosion-proof, Class 1, Division 1, Group 1 exhaust fan with high and low intakes in the door. The exhaust fan shall be located near the floor and shall vent to the outside. The exhaust fan shall be energized by an on-off switch located outside of the room.

(2) Doors with panic hardware.

(3) A leak detector readout with the readout outside.

(4) A leak detector kit located outside.

u) A totalizing, vapor type meter should be provided at the tank installation to record fuel used at the facility. The fuel system shall be sized by adding the demand rates listed herein for each trainer to be constructed.

(1) The propane will be delivered to the individual structures by underground pipe with a single entry to each structure. The propane piping at the site shall be routed in a closed loop so as to maintain a constant supply pressure. Do not use galvanized steel pipe for underground installation. Underground pipe and fittings shall be carefully coated for protection from corrosion and shall be equipped with cathodic protection.

(2) The propane entry shall consist of the apparatus and piping as shown in Appendix J, Figure J-2. A totalizing consumption meter shall be installed on the structure side of the "house valve" to record the amount of propane used by that building. The device contractor will tie into the propane entry as shown in Appendix J, Figure J-2. The propane entry shall be provided outside. A list of valves, fixtures, appurtenances, and controls required for the propane system are shown in Appendix J, Figures J-3 through J-7.

(a) Underground piping located under roadways, parking areas, etc., shall be provided in a vented protective conduit in accordance with API 2510, Design and Construction of LP Gas Installations at Marine and Pipeline Terminals, Natural Gas Processing Plants, Refineries, Petrochemical Plants, and Tank Farms.

(b) Piping from the truck unloading station, storage tank to the vaporizer, and underground piping shall be provided in accordance with ANSI B31.3, Chemical Plant and Petroleum Refinery Piping and shall be Schedule 80.

(3) In addition to the above, a bank of two gaseous propane strainers with isolation valves shall be provided at the propane entry for each training structure. The strainer bank shall be located upstream from the isolation valve serving the flow meter. Each strainer shall be sized and designed as follows:

MIL-HDBK-1027/1

- (a) The propane demand flow rate, CFM.
 - (b) Cast steel 150 psi basket type in-line strainer with flanged connections and ASME code stamp.
 - (c) Provide with a 30 micron filter screen.
 - (d) Support large basket strainers on outside reinforced structural concrete pads. Provide fence with locked gate and warning sign displaying "WARNING - PROPANE. NO SMOKING WITHIN 50 FEET."
 - (e) Designed for outside use.
 - (f) Provide means for cleaning including relieving propane pressure prior to opening the strainer.
 - (g) A manufacturer who can provide this strainer is Stream-Flow-Strainers, Inc., Buffalo, NY, (800) 263-8251.
- v) Safety precautions to be observed in handling LP-gases:
- (1) Smoking and open flames are prohibited in areas of storage tanks, unloading stations, and vaporizer.
 - (2) Motor vehicles are prohibited from entering the storage area. Motor vehicles shall be prohibited from entering or leaving unloading area while transport trucks or tank cars are being unloaded.
 - (3) Test for leaks with soapsuds and a pressure drop test.
 - (4) Connect ground wire to tank cars and truck trailers before any unloading or loading operation is started.
 - (5) Wear rubber (neoprene) gloves when gauging tank cars, truck trailer, and storage tanks and when performing other operations.
 - (6) Keep vapor or liquid off skin and clothing. Liquid in contact with skin produces the same injury as a freeze burn.
 - (7) Thorough ventilation is required in buildings, especially at floor level.
 - (8) Use spark proof tools and explosion proof flashlights.
 - (9) Open valves slowly. If excess flow valves are closed, they may be opened by closing the line discharge valve for a few minutes, thus permitting pressure above and below excess flow valve to equalize internally through the small hole provided for this purpose, enabling the excess flow

MIL-HDBK-1027/1

valve disk to drop into the open position.

(10) The coefficient of thermal expansion of the liquified gas is high, therefore, liquid shall not be confined in any isolated section of pipe except where a pressure relief valve is provided.

(11) Do not overfill storage tanks.

(12) Do not pressurize tank cars above the safety valve setting as stenciled on the car. If faulty equipment on the car prevents normal unloading do not loosen or remove car valves under any circumstances. Fill in "Bad Order Tag" and attach to defective car part. Inform firefighting school supervisor of defective car and await further instructions on disposition of the car.

(13) Bleed vapor and liquid unloading and loading hoses before uncoupling from tank cars or truck transports.

(14) Bleed pressure from vapor compressor crankcase before removing oil fill plug.

(15) Before undertaking repairs the container or section of pipe to be repaired must be isolated by closing valves or physically disconnecting the involved section from communicating lines, as the situation warrants, followed by thorough purging with CO₂.

(16) Hoses and fittings must be maintained in good order. Damaged or unsafe hoses must be removed from unloading area and must not be used for any purpose.

w) The propane interconnection at the device contractor tie-in point will be a block and vent propane entry as shown in Appendix J, Figure J-2. This interconnection will then meet the requirements set forth in NFPA 54 and also the FM insurance requirements.

x) The two most hazardous events associated with the gaseous fuel burning trainers are the fuel handling operations and the accumulation of unburnt fuel in the trainer. The risk of fuel handling operations is mitigated by strict adherence to NFPA 58, DM-22, and this handbook. The risk should be further reduced by having the receiving and storage systems maintained by the device maintenance contractor or someone experienced with large propane systems. The danger from accumulated unburnt fuel in the trainer is adequately eliminated during the occupied period by a system of ventilation, sensors, and interlocks. During the unoccupied period, the risk is reduced by natural ventilation and the proper operation of the key operated Hands-Off Automatic (HOA) switch in the instructor's station. Proper operation requires air flushing and purging the crawl space prior to energizing the crawl space electrical circuits. (See paragraph 3.6.4)

MIL-HDBK-1027/1

y) The maximum fill level (fixed liquid level) gauge on the top of the tank is inconvenient at times to read. Thus, a backup variable liquid level rotogauge may be installed in the center of the tank head. If the float type liquid level gauge is not operating or if you want to check its accuracy, the rotogauge may be used. The rotogauge has a manually operated arm which traces the inside circumference of the tank. When installed and maintained properly, the rotogauge will give you a true reading.

z) The firefighting training facility will have a 24-hour propane detection system provided by the device contractor. Refer to paragraph 2.6.a). The facility contractor is required to interface with the detection system via the Data Terminal Cabinet (DTC) as follows:

(1) For 19F series trainers, provide an alarm system to alarm by sound and flashing warning sign at the quarterdeck or other 24-hour duty station. The warning sign shall state "DANGER - PROPANE ALERT."

(2) For 21C12 series and Seawolf trainers, refer to paragraphs 3.12 and 3.18 for requirements.

2.2.3.2 Natural Gas. Natural gas is largely methane, but includes ethane, propane, and butane. It has two disadvantages in regards to its use as a fuel for 19F series devices. First, the device would have to be modified. Natural gas has less than one-half of the Btu content of propane. Therefore, pipes, nozzles, and other components, would have to be larger to accommodate the increased flow rate. The flame characteristics so important to realism also would be different. Additionally, natural gas is lighter than air, with air having specific gravity equal to 1, natural gas has a specific gravity between .58 and .70. The trainer architectural and safety aspects would have to be redesigned for this lighter than air hazard. Second, tests have not been run to determine the effect that using natural gas would have on the training environment. Therefore, natural gas cannot be used for the device training fires. Natural gas, however, can be used as a heating fuel.

2.2.3.3 Oil and Gasoline. Oil and gasoline are no longer preferred as firefighting school fuels. These liquid hydrocarbon fuels produce many kinds of air and water pollution which can only be partially treated at great cost and may not be acceptable by the local, state, or federal environmental regulations.

2.2.4 Water

2.2.4.1 Potable Water. Potable water shall meet the following criteria:

a) Firefighting facilities based on the 19F and 21C12 series trainers shall use fresh water throughout. Salt water cannot be used because of the corrosive effect on the expensive device.

b) Recycled water can be used. Previous tests have indicated that wastewater treatment would be required to provide recycled water. The training

MIL-HDBK-1027/1

structure effluent contains a large Chemical Oxygen Demand (COD) that would have to be removed before delivering it back to the fire field. Refer to paragraph 5.3.3 for wastewater characteristics.

c) Water delivered to the site should be metered and supplied through a backflow preventer in accordance with AWWA C506, Backflow Prevention Devices--Reduced Pressure Principle and Doublecheck Valve Types. The pressure drop of this equipment must be considered when calculating the availability of water.

d) The range for water or foam pressure at the hose nozzle for the 19F series trainers is 120 to 140 psi (113.1 to 133.106 kPa). Submarine trainers (21C12) require a minimum nozzle pressure of 50 psi (344.7 kPa). The design point for the pumps should be chosen at least 25 percent higher (172 psi and 63 psi (1,185 to 434.3 kPa) respectively) to allow for hydraulic losses and wear.

e) The water system shall be sized by summing the demand and consumption listed herein for each 19F and 21C12 series trainer.

f) During the development of the project, the EFD Code 16 (Utilities Division) must verify a reliable source of potable water. Water usage rates should be determined based on a once-through water system. Water flow tests should be conducted to determine the adequacy of the water supply system.

g) Other than the firefighting water, potable water for drinking and cool-down showers should be supplied to each device structure. The drinking fountain should be a pipe which shoots the water in an arch to a drain and the shower should be an emergency shower. Eyewash showers are not required.

h) Emergency water is defined as water delivered under pressure, over 100 psi (689.4 kPa) during a power outage. Emergency water is not required for the 19F and 21C12 series trainers because water could not extinguish the fire in an emergency.

2.2.4.2 Water Storage. Sufficient water storage shall be provided to ensure that the water demand can be met under all operating conditions without starving the pump suction. Water storage shall be available on the site or in the vicinity. Water storage shall be sufficient to supply the facility needs such that once a class is started (including classroom time), it can be finished. The water storage tank shall be designed in accordance to AWWA standards and shall include the following: level gauge, automatic means for filling, vent, manways, OSHA approved ladders, etc.

2.2.5 Wastewater. Effluent from the training structures shall be collected in an equalization tank, treated, and pumped at a metered rate into the sanitary sewer system. The ultimate disposal of the effluent must be through a biological treatment process. If the Public Owned Treatment Works (POTW) does not incorporate that degree of treatment, the fire facility must biologically

MIL-HDBK-1027/1

treat the wastewater prior to discharging it (refer to Section 5).

2.2.6 Electrical Power. Sufficient electrical power shall be provided in underground conduit to each structure to meet the needs of the building and device equipment, including the computer. Demand quantities are listed herein. Spare capacity shall be provided in both power and control conduits. Separate conduits shall be used for power and control wiring. Spare conduits for the device contractor's use are identified under the respective trainer's requirement.

2.3 Supporting Facilities. Firefighting facilities shall have a utilities building and a bulk storage building with an agent bottle refill.

2.3.1 Utilities Building. The utilities building design shall conform to the following criteria:

- a) The utilities building shall have a minimum floor area of 2500 square feet (ft²).
- b) The utilities building shall include water pumps, foam concentrate mixing station, motor control centers, wastewater treatment monitoring equipment, central utility annunciator panel, and a maintenance area.
- c) A minimum of two pumps piped in parallel shall be provided to supply 140 psi (965.1 kPa) water to the farthest hose nozzle on all but submarine trainers. Submarine trainers require 50 psig (344.7 kPa) water at the hose nozzle. For submarine trainers, provide one full-sized pump for standby when existing potable water pressure is sufficient; when potable water pressure is low, two full-sized booster pumps shall be provided in parallel. The pumping system shall be designed as an industrial process system and not to meet normal fire protection requirements. A flow sensor shall be provided to turn on the second pump, based on demand. The second pump shall be protected from short cycling with a timer which keeps the pump running for at least 10 minutes, regardless of demand. Each pump shall be rated for continuous duty and shall include a non-slam check valve. The design of the water system shall be such that the pumps are protected from "dead head" during erratic demand variations experienced at a firefighting training facility. The method of relieving "dead head" pressure should ensure that the pump cannot overheat during this condition. The pressure relief should be by diaphragm relief valve. A manual lead pump select switch shall be provided and the lead pump shall be started manually. Process water piping serving the hose stations shall be painted red.
- d) Aqueous Film-Forming Foam (AFFF) are concentrates, based on fluorinated surfactants plus foam stabilizers, usually diluted with water to a 3 to 6 percent solution. The foam formed acts both as a barrier to exclude air or oxygen, and to develop an aqueous film on the fuel surface capable of suppressing the evolution of fuel vapors. The foam produced with AFFF concentrate is dry chemical compatible and thus is suitable for combined use with dry chemicals. At firefighting training facilities, an AFFF surrogate is

MIL-HDBK-1027/1

used in lieu of real AFFF for cost and environmental reasons. The foam surrogate concentrate, Calsoft, Ultrawet K, or equivalent, will be delivered and stored in bulk form. Refer to paragraph 4.2 for details on AFFF. It will be pumped to the utilities building concentrate mixing tank where it will be diluted with potable water to a strength equal to 100 percent AFFF concentrate. A batch process shall be used and provisions for mixing should be included to prepare the solution. The method chosen for mixing shall consider the potential foaming problem. The 100-percent solution will be pumped as required to each proportioner holding tank on the fire field. It will also be used to fill 5-gallon foam concentrate cans for use in the training structures. Carbon steel cannot be used for piping and storage of Calsoft, Ultrawet K, or equivalent. Acceptable materials are stainless steel and copper piping. AFFF concentrate piping tanks and appurtenances shall be painted green. All 6 percent and 3 percent AFFF piping shall be painted green and red striped.

e) An electrical room should be provided in the utilities building to house electric controls and utilities related motor control centers, such as, water, fuel, chemicals, waste pumps, and others.

f) Utility system information, such as pressures, temperatures, liquid levels, run status, and flows shall be brought to a central annunciator panel. The fuel information shall be sensed indirectly so that no fuel is piped inside the building. Tanks and reservoirs shall have level indicator devices.

2.3.2 Storage and Refill. Storage and refill facilities shall meet the following criteria:

a) A minimum floor area of 2500 ft² shall be provided for bulk storage for all trainers, except the 21C12 trainer which shall have a minimum of 1200 ft² of floor area.

b) Bulk storage shall be provided for large CO₂ bottles, palletized Purple Potassium Powder (PKP) containers, 5-gallon cans of foam concentrate, PKP and CO₂ extinguishers, and OBA canisters. This storage shall be kept from freezing and kept dry. The maximum temperature should not exceed 125 degrees Fahrenheit (F) (51.6 degrees Celsius (C)). The layout should consider the handling of material by fork truck. A minimum of 100 ft² (9.2 square meters (m²)) of well ventilated space should be provided for filling empty PKP and CO₂ fire extinguishers. This area shall contain scales and support jigs to facilitate the filling operation which should be done in accordance with NAVSHIPS Technical Manual, Chapter 55, Section 555-4.1.

c) Additional storage may be required for storing of collateral equipment and spare parts. Contact the using activity for requirements.

d) The dry storage and refill areas shall contain floor drains which lead to the equalization tanks.

2.4 Other Facilities

MIL-HDBK-1027/1

2.4.1 P-250 Demonstration. Provide the P-250 demonstration with all 19F type trainers. The P-250 pump cannot be mounted on the 19F4 trainers.

P-250 demonstration facilities shall meet the following criteria:

a) The P-250 is a gasoline-powered, portable water pump. For demonstration, an in-ground sump of a minimum 1,100 gal (4,163.5 L) shall be provided along with bleachers for the trainees (see Appendix A, Figure A-15). The sump shall have a drain and a 2-inch (50.8 mm) fill valve. A chain rail shall be provided for personnel safety. During the demonstration, the pump shall take suction from the sump and discharge back to it.

b) When the installation is located inside an enclosed structure, the exhaust from the gasoline engine must be removed. The P-250 pump uses process water for bearing lubrication. This water shall be discharged through the exhaust pipe. An exhaust system shall be provided to carry away the exhaust including a trapped drain to carry the lubrication water to the equalization tanks. Refer to paragraph 5.3.3 on pretreatment and equalization tanks. For outside P-250 locations, means shall be provided to drain the lubrication water to the equalization tanks. The lubrication water could contain small amounts of oil and gasoline. The drains serving the P-250 pump shall be piped to an oil and water separator for removal of gasoline and oil from the P-250 pump lubrication water. A new P-250 pump has been introduced which eliminates oil and gasoline in the lubrication water.

2.4.2 Wild Hose. Provide the wild hose demonstration with all 19F type trainers. The wild hose cannot be mounted on the 19F4 and 19F4A trainers.

The wild hose demonstration area shall meet the following criteria:

a) The wild hose demonstration area shall include access to a 1-1/2-inch (63.5 mm) hose station, 100 feet (30.5 m) of 2-1/2-inch hose, 2-1/2- to 1-1/2-inch adapter, another small section of 1-1/2-inch hose, and a 10-foot high steel pipe column. A section of 1-1/2-inch hose shall be strapped to the column with 8-feet (2.4 m) hanging loose from the top. The other end of the 1-1/2-inch hose section shall be at ground level to allow coupling of the longer hose. (Refer to Appendix A, Figure A-13.)

b) The wild hose shall be installed outdoors except in extreme climate locations where an enclosed area is a necessity for year-round training. Enclosed areas inside training structures shall be provided with Plexiglas barriers to facilitate viewing the wild hose without getting personnel wet.

Caution: The length of the free end of hose with the nozzle must always be less than the distance to the walls, ceiling, and floor to prevent damage to the structure.

MIL-HDBK-1027/1

2.4.3 Smoke House. A separate facility for smoke training has not been identified.

2.4.4 Hose Drying Area. A rack shall be provided for laying out twelve 50-foot (15.2 m) lengths of hose to dry. It shall be located in an open area if possible to take advantage of natural air movement. The hoses shall lay on an angle to promote drainage. One rack per training structure shall be provided.

2.4.5 Maintenance Contractor Area. The maintenance contractor area shall be a work or office type room with an 8-foot high ceiling to be used by the device maintenance contractor. The minimum floor areas shall be as follows:

- a) For 19F5, 19F5A, 21C12, and 21C12A trainers, 120 ft².
- b) For 19F1A, 19F1B, 19F3, 19F3B, 19F3A, 19F3C, 19F4, or 19F4A trainers, 480 ft².
- c) For other training devices, locate the maintenance contractor area at the utility building or other support building.

2.4.5.1 Room Provisions. The room shall be provided with the following:

- a) Telephone connection
- b) Air conditioning, heating, and ventilation
- c) 120 volt, single phase, heavy duty electrical outlet
- d) Lighting
- e) Lockable door

2.5 Interfaces

2.5.1 General. Firefighting training facilities are procured through two separate contracts. The first is a construction contract which provides the training structure, the site development, the supporting facilities, and the utilities. The second is a device contract which provides the trainer, computer, and its related equipment. Everything discussed in this handbook shall be provided by the facilities contractor unless indicated otherwise. Two copies of Military Construction (MILCON) project facility drawings and any changes thereof, and as-builts shall be supplied to NTSC when available.

2.5.2 Device Contractor. The device contractor shall provide the following equipment:

- a) Fireplace mockups
- b) Nonfireplace mockups

MIL-HDBK-1027/1

- c) Teltale and obscuration smoke systems
- d) Halon and Aqueous Potassium Carbonate (APC) agent simulators
- e) Explosive gas monitoring system (propane detectors)
- f) Temperature and safety monitors
- g) Training and maintenance communication devices
- h) Ventilation devices used by the trainee
- i) Shiplike labelings
- j) Power ventilation necessary to distribute smoke
- k) Equipment necessary to "clean up" electrical service
- l) Equipment necessary for electromagnetic shielding
- m) Special compartment lighting
- n) Bulkhead rib insulation (21C12)
- o) Partitions in 21C12 instructor's station
- p) Flush deck nozzle system (19F4)
- q) Bulkhead flapper (21C12 and 21C12A)
- r) Red Devil blower and adapter (21C12 and 21C12A)

2.5.3 Construction Contractor. Unless indicated otherwise, device services shall be brought to a single point close to the exterior of the training structure. The device contractor shall make final connections after the construction contractor leaves the site.

2.5.3.1 Electric. Electrical service designated for the device and computer shall terminate in a single-fused disconnect in the electric room near the instructor's station. For those buildings without an instructor's station, the disconnect shall be located in a ground-level burner room, and shall be explosion-proof, refer to paragraph 3.6.4 c) for explosion-proof requirements.

Power for facilities installed equipment, such as, lights and exhaust fans, shall be run through a separate, fused disconnect and wired ready for use. This disconnect shall be located in a ground-level burner room and shall be explosion-proof, refer to paragraph 3.6.4 c) for explosion-proof requirements.

MIL-HDBK-1027/1

The power provided shall be directly from the station or municipal grid system. If the power source needs to be modified or "cleaned up" to protect the computer equipment, the device contractor will provide the necessary equipment.

2.5.3.2 Data Terminal Cabinet (DTC). Exhaust fans, motorized dampers, and motorized valves located in, a trainer shall be controlled by individual, HOA switches in the instructors station. The automatic mode shall have the necessary relays to be energized by a 24-Vac, 100 mA, binary signal from the future device computer. Wire each relay to the DTC. The DTC shall be located in the instructor's station. Except the DTC for the 19F4 trainer shall be located in the electrical space below the instructor's station. Controls which are recommended to be wired to the DTC shall include the HOA switches and relay mentioned above. The 24-Vac relays associated with HOA switches wired to the DTC shall be provided with arc suppression protection. The use of non-suppressed relays can produce a large voltage which is detrimental to the device computers.

The DTC shall include a terminal strip where these controls are wired to unique lugs. Mating lugs on the terminal strip shall be ready for the device contractor to tie into to complete the installation. Each lug shall be identified by the facilities contractor by the function connected to it. For typical control interface, refer to Appendix A, Figure A-14.

2.5.3.3 Fuel. Refer to paragraph 2.2.3.

2.5.3.4 Fireplace. Areas indicated on the floor plans as fireplace areas shall have no floor grating or plate and shall be free of any structural members. Provisions for supporting the future device are shown in Appendix A, Figure A-9. A temporary post and chain railing shall be provided around the opening for safety until the device is installed.

2.5.3.5 APC Extinguishing Agent Simulation. Provide a 1-1/2-inch (38.1 mm) fire water line to the deep fat fryer fireplace and terminate with a globe valve below the floor grating.

2.6 Device. (For information only and does not pertain to the device contract.) The device equipment provided in the trainers consist of the following:

a) The fireplaces shall be computer-controlled propane burners hidden in a mockup which is designed to represent the item burning. Refer to Appendix A, Figures A-1, A-2, and A-3. Most fireplaces will be floor-mounted and fed from the crawl space. The fireplaces which are not fed from the crawl spaces, such as: electrical panel, wire bundle, and vent duct fires, shall include propane equipment in their electrical cabinets. Each of these cabinets will contain a propane sniffer which will detect any propane which has leaked into the cabinet. There will also be propane sensors on both sides of the wall underneath electrical cabinets containing burners. When activated, this sniffer will shut down its fireplace until the propane is removed from the area.

MIL-HDBK-1027/1

b) Device equipment shall be designed to go through a 36-inch (914.4 mm) personnel door unless other provisions are made.

c) The artificial smoke generator (provided by the device contractor) is started at the beginning of a training session and runs continuously. Air at 1,000 degrees F (538 degrees C) shall be discharged from bypass ducts which keep the system at operating temperature. The unit requires one-half hour at the start to attain operating temperature. When smoke is required, the chemical is injected into the hot air and ducted to the proper location. The building ventilation should remain on even during the application of smoke. The bypass duct should discharge into the ventilation system or be controlled so that no artificial smoke can exit through it. Different smoke generation rates are obtained by relieving air before the chemical is injected into it.

d) The smoke generator shall be powered by propane and electricity and located on the ground adjacent to the training structure.

2.7 Gas Chamber

2.7.1 General. The gas chamber shall be used to provide chemical warfare countermeasures training; it is not part of the 19F and 21C12 series firefighting structure. However, the gas chamber shall usually be provided with the 19F5 facility. The chemical agent to be used for training is tear gas. The gas chamber shall be used to train 1 class of 100 personnel at a time, 2 to 3 classes per day, and 20 classes per week.

2.7.2 Training. Recruits and instructors will march into the gas chamber wearing the MCU2/P gas masks. Prior to their entrance in the chamber, tear gas is made on a hot plate and is subsequently exposed to the recruits as they remove their gas masks. When gas training is complete, the recruits and instructors march out of the chamber to an area where they can get fresh air. After completion of gas training, an instructor opens the emergency exit/vent doors and energizes the exhaust system to exhaust the tear gas-laden air from the gas chamber. During winter, the instructor will deenergize the heating system prior to energizing the exhaust system. When tear gas has been removed from the gas chamber, the exhaust system will be deenergized and the heating system will be energized, as required. After each use, the gas masks will be sterilized by the recruits by dipping or wiping the masks with a 2 percent iodine and 98 percent water solution. The masks are then rinsed or wiped with water and wiped dry.

2.7.3 Site Development. The gas chamber shall be a separate structure and shall be located at least 50 feet (15.24 m) away from any building or facility to prevent the migration of tear gas into an occupied area or building. Consideration shall be given to the prevailing wind direction. The gas chamber discharge shall be sited so that tear gas is not blown to occupied areas or buildings located downwind.

MIL-HDBK-1027/1

2.7.4 Architectural. The floor plan for the gas chamber is provided in Appendix H, Figure H-1.

2.7.4.1 Layout. Layout of the gas chamber shall conform to the following criteria:

a) The gas chamber shall be a 1,300 ft² (119.6 m²), one-story building consisting of a 30-foot by 30-foot (9.14 m by 9.14 m) gas chamber room, a decontamination station, a storage room, and a mechanical room.

b) The building shall consist of concrete-masonry-unit wall construction. The ceiling shall be an 8-foot (2.4 m) high gypsum-board type. A protective sealant shall be applied to both the walls and the ceiling of the gas chamber room. The sealant shall be chemically-resistant to tear gas (vapor and powder) and capable of preventing the migration of tear gas and water through the walls and the ceiling of the gas chamber room.

c) There shall be means of access to the space above the ceiling, which will be used for maintenance purposes. Access to the ceiling shall be via the storage locker or the mechanical room. The doors shall be the insulated, hollow metal type. Each door shall be provided with a clear 18-inch by 18-inch (456.2 mm by 456.2 mm) shatterproof window. There shall be no windows in the walls. Emergency exit doors shall be provided with panic hardware.

2.7.4.2 Decontamination Station. The decontamination station shall be used for sterilizing the gas masks. The decontamination shall consist of an iodine-water solution sink for sterilizing the gas masks, a rinse water sink for rinsing the gas masks, and a drying counter or table for hand drying the masks. The sinks and counter or table shall be stainless steel.

2.7.4.3 Storage Locker. Gas masks, tear gas powder or capsules, and collateral equipment shall be stored in the storage locker separated from the gas chamber. Built-in wall storage consisting of pigeon-hole type compartments shall be provided in the storage locker for storing 200 gas masks with haversacks. Refer to Appendix H, Figure H-2, for detail information pertaining to wall storage.

2.7.4.4 Collateral Equipment. Collateral equipment to be furnished by the station are:

- a) Washdown hose and storage rack
- b) Hot plates
- c) Hot plate counters
- d) Gas masks

2.7.5 Plumbing. Hot and cold water shall be provided to the sinks in the

MIL-HDBK-1027/1

decontamination station. Floor drains shall be provided in the gas chamber room and decontamination room. A 3/4-inch (19 mm) hose bib shall be provided in the gas chamber room for hose washdown of floors, walls, and ceiling. All drains shall connect into piping leading to equalization basin.

2.7.6 Mechanical. A mechanical exhaust and winter heating system shall be provided for the building (heat the building to 50 degrees F (10 degrees C) inside). No air conditioning shall be provided. The mechanical exhaust system shall be separate from the heating system and shall be provided for the gas chamber room. The exhaust system shall be sized for 60 air changes per hour. A sign shall be placed on the gas chamber room wall, near the exhaust system controls, stating, "IMPORTANT - WHEN OPERATING EXHAUST SYSTEM, TURN OFF HEATING SYSTEM AND OPEN ALL DOORS." The exhaust fan shall have a non-overloading wheel. The exhaust system shall contain a discharge stack to disperse the tear gas high enough into the air above the building to prevent recirculation back into the gas chamber and migration to other areas and buildings. The exhaust system shall contain a motorized damper which will be closed during gas training to prevent the loss of tear gas. An air heating system shall not be used for heating the building. The heating system shall consist of unit heaters or fin tube radiation. The heating equipment shall be designed for water cleaning by hose and shall also be able to withstand the accumulation of tear gas powder.

During tear gas training, when the recruits are entering the gas chamber room, the heating will be turned off by the instructor. When recruits are in the gas chamber, the instructor will turn the heating systems back on. The exhaust system will be off throughout the gas training. After completion of gas training, the instructor will turn the heating system off in the gas chamber room, open doors and energize the exhaust system to rid the gas chamber of tear gas. After exhausting the tear gas out of the chamber, the instructor will turn the exhaust system off and energize the heating system.

2.7.7 Electrical. Lighting shall be provided in gas chamber rooms. Waterproof, surface-mounted, incandescent light fixtures shall be provided in the gas chamber room. Three heavy-duty, waterproof wall outlets shall be provided in the gas chamber room. Two of the wall outlets shall be located near the hot plates. A red, rotating beam light shall be provided outside at the main entrance to the chamber to serve as a warning light during training. A sign shall be placed on the building, near the main entrance, stating, "CAUTION - GAS TRAINING IN PROGRESS WHEN RED LIGHT IS FLASHING." Electrical power to the building shall be 120/208 Vac/single phase/60 Hz.

2.7.8 Tear Gas Characteristics. Tear gas is available in two forms; powder and powder-in-capsule. Approximately 1 to 3 teaspoons (6.5 grams/tsp) of powdered tear gas will be used per class for the gas chamber.

- a) Chemical: alpha-chloroacetophenone, $C_6H_5COCH_2Cl$
- b) Threshold Limit Value (TLV): 0.3 mg/m^3 or 0.05 parts per million (ppm)

MIL-HDBK-1027/1

- c) Melting Point: 138 degrees F (59 degrees C)
- d) Density: 1.324 gram/ml (powder)
- e) Vapor Pressure: 0.012 mm of mercury

MIL-HDBK-1027/1

Section 3: TRAINING STRUCTURE

3.1 Training Courses. The various 19F and 21C12 series firefighting trainers have been designed to support the following courses:

- a) J-495-0418 - General Shipboard Firefighting Training Course: Taught in the 19F3 and 19F3A trainers, a 2-day course for a maximum of 108 students in the 19F3 and 60 students in the 19F3A. The students are exposed to Class A, B, and C type fires.
- b) J-425-0424 - Advanced Shipboard Firefighting Team Evaluation Course: Taught in the 19F1A and 19F3A trainers, a 2-day course for a maximum of 30 students. The students must locate, identify, and extinguish the classes of fires and communicate with Damage Control Central.
- c) J-495-0413 - Shipboard Aircraft Firefighting Training Course: Taught in the 19F4 trainer, a 2-day course for a maximum of 60 students. The students will conduct firefighting and rescue exercises with fixed wing and helicopter crash fires.
- d) J-495-0414 - Aviation Facility Ship Helicopter Firefighting Team Training Course: Taught in the 19F4 trainer, a one-day course for a maximum of 29 students. The students will conduct firefighting exercises with helicopter crash fires.
- e) J-495-0424 - Advanced Shipboard Firefighting Team Training Course: Taught in the 19F1A and 19F3A trainers, a 4-day course for a maximum of 30 students.
- f) A060-0011 - Basic Enlisted Submarine School.
- g) A2E-0044 - Submarine Basic Officer Course.
- h) F495-0010 - General Submarine Firefighting.

Subparagraphs f) through h) taught in the 21C12 and 21C12A trainers, ten 4-hour classes per week (two classes per day) for a maximum of 25 students in each class.

3.2 General. The training structure shall be designed to house the various 19F and 21C12 series devices and provide realistic training situations. It must be ruggedly constructed to withstand the temperature cycling from the intense heat of the flame to a stream of cold water from a hose. It shall withstand the impact of a high velocity hose stream.

3.2.1 Heat Protection. Building structural components must have sufficient room for thermal expansion. The maximum flame temperature of the device is 1,650 degrees F (899 degrees C) when using propane fuel. Assume the products of combustion reach 660 degrees F (349 degrees C) and an individual compartment may

MIL-HDBK-1027/1

reach 400 degrees F (260 degrees C). Any item located in a compartment should be able to withstand the radiant heat or be shielded from it. It takes about 5 minutes for a small fireplace and about 20 minutes for a large fireplace, such as a bilge fire, to return to the starting temperature assuming 2 minutes of cooling water spray.

3.2.2 Personnel Spacing. There will be approximately 5 feet (1.5 m) of spacing between trainees on a hose team.

3.2.3 Weather and Freeze Protection. Weather protection of the training structure shall meet the following criteria:

a) The structures shall be sufficiently enclosed and heated to allow training in subfreezing weather (where this is a requirement) without adverse effects, such as, ice buildup on grating or doors. Other than for training and water freeze protection, there is no low temperature limit on the structure or associated equipment during off hours.

b) The crawl space should be heated to 40 degrees F (4.10 degrees C) during unoccupied hours to maintain the structure above freezing. Unit heaters should be used to provide heat. Unit heaters shall be rated for Class 1, Division 1 environments.

c) During occupied hours, enclosed staging areas shall be heated to 50 degrees F (10 degrees C) and also shall be ventilated for summer heat removal. The staging area ventilation should be the forced type so the pressure there is always above the compartment pressure. This will ensure that the smoke stays in the training compartments.

d) When roof staging areas and second story emergency walkways are enclosed, a 6- by 8-foot (1.8 by 2.4 m) high removable wall panel in the staging area shall be provided. This will allow larger equipment to be hoisted during installation and maintenance.

e) Staging areas shall drain into the structure to ensure that firefighting agents and rainwater are collected. Staging areas shall be provided with trench type drains. Rainwater from roofs does not have to go to the crawl space.

3.2.4 Drainage. The area around exterior trainee entries to a fire space should be provided with an apron which slopes to a drain. The drain should lead to the wastewater treatment system. This apron will collect the firefighting agent used to cool the door prior to student entry and should be large enough for that purpose. If the apron will be subject to collecting rainwater, a pair of post indicator valves should be placed on the drain line; one should lead to the storm drain, the other should lead to the wastewater treatment. It will be the instructor's responsibility to correctly position the valves so the rainwater goes to the storm drain when the structure is not in use and the training water goes to treatment when the structure is occupied.

MIL-HDBK-1027/1

3.2.4.1 Drainage Piping Material. Because of exposure to heat and AFFF, the drainage piping in the training structure shall be capable of withstanding 750 degrees F and shall be constructed of either copper or stainless steel.

3.2.5 Escape Trunks. Escape trunks shall be 5 feet on a side and shall descend from the roof to the first floor by way of a vertical wraparound ladder. The roof entry shall be a small hatch and the lower entry shall be an Ellison door. A horizontal safety net shall be stretched across the escape trunk at a maximum of 8-foot intervals. The safety net in escape trunks shall be first quality parachute nylon webbing in accordance with BUSHIPS Dwg. 804-5184163 . Webbing shall have 1,750 lb test load and shall be waterproof. Borders shall have safety snaps for attachment to wall-mounted eyelets. The net shall be fastened to the walls so it can be removed for maintenance. Provide a 3-foot by 3-foot (0.91-m by .91-m) opening in the safety net where the ladder passes through. Provide door in escape trunk for access from crawl space area for maintenance. The door shall have louvers for ventilation. The escape trunk shall be provided with 2,000 cfm mechanical ventilation with the supply air coming from the crawl space. Refer to paragraph 3.11.10.2.

3.2.6 Consumables. Each 19F and 21C12 series trainer was designed to handle a specified student loading as indicated herein. The training schedule and demand and consumption of consumables are also indicated. When the student loading of a proposed project differs substantially from the indicated values, the design demand and consumption may be proportioned up or down to suit the project.

3.2.7 Burner Rooms. The burner rooms shall have a minimum ceiling height of 7 feet (2.1 m) and a floor level with the crawl space floor. The device contractor will provide the necessary hardware for mounting and maintaining the training components away from the air intake louvers. For access into the burner room where a change in elevation occurs, provide stairs with a landing and railing.

3.2.8 Obstructions. Provide obstructions where they are indicated on the floor plan drawings in the appendices. Obstructions shall be constructed of 3/16-inch (4.8 mm) steel plate, making a solid top and sides and having an open bottom. Obstructions shall be bolted to the floor grating from underneath in such a way that they can be positioned anywhere in the room.

3.2.9 Separation Chamber and Piping Traps

a) Effluent coming from a fire training structure shall dump into a separation chamber. The primary purpose of the chamber is to separate the propane which accumulates in the pipe peripheral air space from the remainder of the wastewater piping. The chamber shall be open at the top or covered with a 6-inch (152.4 mm) diameter vent pipe. The inlet shall be valved with a lockable post indicator type valve, and shall be high enough above the outlet invert so the influent can fall even in freezing weather. The inlet shall be

MIL-HDBK-1027/1

baffled. Both inlet and outlet shall terminate inside the chamber with a pipe flange and sufficient room for a future pipe fitting. The outlet shall be a dip tube which draws from the bottom of the chamber. A running trap shall be provided in the outlet line adjacent to the chamber (refer to Appendix A, Figure A-16 for separation chamber detail).

b) "NO SMOKING" signs shall be posted facing all directions around the separation chamber since it is a source of propane.

c) No traps shall be provided in the piping leading from the crawl spaces. Floor drains leading from other spaces in the training structure shall have vented traps or shall tie into the wastewater line upstream of the separation chamber running trap. This precaution will prevent propane migration through the piping.

3.2.10 Fireplace Compartment Dimensions. The dimensions given for the fireplace compartment sizes are inside clear dimensions. These inside clear dimensions are critical and must be maintained. For example, if a fireplace compartment has refractory coatings and steel plate liners on the walls, then the inside clear dimensions are from liner to liner of the walls.

3.3 Repair or Crash Lockers. Each structure, except the 21C12 and 21C12A trainers, shall have at least one repair locker to house the paraphernalia required for firefighting. Unless indicated otherwise, repair lockers shall be 10 feet (3 m) on a side with an 8-foot high (2.4 m) sloping roof and gutter. Repair lockers shall have natural ventilation at floor and roof and shall have a floor drain. Hollow metal doors shall be used on repair locker entries. The following repair locker equipment will be provided by the respective training school:

- a) Damage control plotting board to track status of the fire and extinguishment process
- b) OBA canisters and OBA's
- c) CO₂ bottles
- d) PKP bottles
- e) Repair parts
- f) Nozzles

Crash lockers shall be the same as repair lockers.

3.4 Doors and Hatches. The various types of entryways defined here are used throughout the firefighting training structures. Doors used for emergency exits must be adequately marked.

MIL-HDBK-1027/1

3.4.1 Watertight Doors. Watertight doors shall be provided in accordance with NAVSHIPS Dwg. 805-1400066, galvanized steel with three dogs unless indicated otherwise, refer to Appendix A, Figure A-12. Refer to NAVSHIPS Dwg. 805-1400074 for details of airtight doors. Airtight doors as shown on NAVSHIPS Dwg. 805-1400074 can be used in lieu of watertight doors since submergence in water is not a requirement. Airtight doors are a good simulation to watertight doors. No hasp assembly is required. Three dogs are used instead of eight because the door will warp when subjected to heat and many of the dogs would not work. Since the door will have to be replaced periodically because of warping, it is desired to keep the door as inexpensive as possible. Quick-acting watertight doors shall be a watertight door provided with a single lever to operate the three dogs at once. Refer to Appendix A, Figure A-7. Quick-acting, airtight doors shall be provided in accordance with NAVSHIPS Dwg. 805-1400074.

3.4.2 Hollow Metal Doors. Hollow metal doors shall be standard exterior doors with standard door knobs. Panic hardware shall not be used even if the door is labeled an emergency exit. This hardware is expensive and will not stand up to the heat. Typically, doors shall be 3-feet wide except that doors to instructors' stations, burner/electrical rooms, and electrical equipment rooms shall be 4-feet minimum width doors to allow for equipment access.

3.4.3 Wire Mesh Doors. Wire mesh doors shall be constructed of 1-1/2-inch (38.1 mm) angle steel with 3/8-inch (9.5 mm) by 1/2-inch (12.7 mm) steel wire mesh fastened to it.

3.4.4 Automatic Closing (Ellison) Doors. Automatic closing (Ellison) doors shall be in accordance with NAVSHIPS Dwg. 803-5184129. Refer to Appendix A, Figure A-8. Ellison doors are nonwatertight, steel, balanced doors which close automatically by the action of an internal spring. Ellison doors must be shielded from the radiant heat of the fireplaces. The door shall be 36 inches (914.4 mm) wide. These doors are considered to be proprietary and are provided by Ellison Bronze Co., Inc.

3.4.5 Large Hatch. A large hatch shall be provided in accordance with BUSHIPS Dwg. 805-1624089. This hatch shall be 36 by 60 inches (914.4 by 1.524 m) with six wrench-operated dogs, spring-balanced and shall include a 25-inch (635 mm), quick-acting, spring-balanced, raised scuttle.

3.4.6 Small Hatch. A small hatch shall be provided in accordance with BUSHIPS Dwg. 805-1624122. This hatch is 24 by 30 inches (609.6 by 762 mm) raised, oval, quick-acting, and spring-balanced. It shall include 13-inch (330.2 mm) diameter handwheels on both sides which operate four dogs.

3.5 Ladders

3.5.1 Inclined Ladders. Inclined ladders shall be designed in accordance with NAVSHIPS Dwg. 805-1749113. The slope of the ladder shall not exceed 60 degrees from the horizontal and unless indicated otherwise, shall have landings at either end with a minimum of 3.5 feet (1.06 m) clear space. When the ladder

MIL-HDBK-1027/1

rises more than 14 feet (4.26 m), an intermediate landing shall be provided.

The top tread of an inclined ladder shall be 9 inches (228.6 mm) wide and start 2 inches (50.8 mm) away from the deck cowling. Other treads shall be 6 inches (152.4 mm) wide. Non-slip treads, within wet conditions, shall be used exclusively.

3.5.2 Vertical Ladders. Vertical ladders shall be designed in accordance with NAVSHIPS Dwg. 804-1749235. Following standard shipboard design, the wraparound ladder rungs shall be 7 inches (177.8 mm) from the wall. The rungs shall be of serrated stainless steel to provide a nonslip surface. A 9 ft² (0.83 m²) opening shall be provided in the safety net where the ladder passes through.

3.6 Lighting and Electrical

3.6.1 General Lighting. General lighting shall be provided for each space in a firefighting structure using appropriate building type fixtures and switches.

The fireplace areas shall use indirect lighting from the crawl space areas. The fixture shall be wall mounted (at 3 feet Above Finished Floor (AFF)), facing outward or with a (25 degree) stanchion. Luminaires shall not be floor mounted, facing upward. Provide a fixture similar to that shown in Appendix A, Figure A-22. Specify the particular type and lamp wattage appropriate for the design (Type 1 or 2). Luminaires shall meet Underwriters Laboratories Inc. (UL) 844, Electric Lighting Fixtures for Use in Hazardous (Classified) Locations, for hazardous locations and UL 595, Marine-Type Electric Lighting Fixtures, for marine locations. A globe guard shall be provided. The above requirements will: (a) protect the fixtures from heat and direct spray of the water; (b) allow for the water to drain away from the fixture; and (c) avoid letting water penetrate the fixture and conduit system. These lighting levels are not intended for use with training personnel. The lights in the crawl spaces are only intended to aid and supplement maintenance and inspection personnel who carry individual task lighting. Provide approximately five footcandles of illumination level. The light switches associated with the crawl space lights shall be located outside the entryway(s) for the compartments.

It is requested that the following requirement be added to the Operation and Maintenance Support Information (OMSI) for the facility:

Perform monthly inspection of the two gaskets (ballast and globe) associated with each fixture. Replace gasket when deterioration is evident.

Staging areas shall be provided with general lighting for nighttime operation.

3.6.2 Special Compartment Lighting. Special compartment lighting shall be provided for use by the trainee and shall be provided and controlled by the

MIL-HDBK-1027/1

device contractor.

Every attempt should be made to minimize the length of conduit in the compartment. When conduit is run in the compartment it shall be shielded from the fire and water spray and shall contain wire with high temperature insulation suitable for greater than 600 degrees F (315.5 degrees C). High temperature wire shall be in accordance with Military Specification MIL-W-25038, Wire, Electrical, High Temperature and Fire Resistant, Type 1.

3.6.3 120-Volt Alternating Current (Vac) Convenience Outlets. The 120-Vac convenience outlets shall be provided in the crawl spaces, burner rooms, and instructor's station.

3.6.4 Electrical Interlocks in Crawl Space and Burner Rooms. The electrical interlocks in crawl spaces and burner room shall meet the following criteria:

a) Provide a lockable, key operated HOA switch in the instructor's station to disable lighting circuits, receptacle circuits, and power circuits in the crawl space(s) and burner room(s). Electrical, lighting, and power circuits in the crawl space and burner rooms shall be rated explosion-proof in accordance with paragraph 3.6.3 c) below. The HOA switch shall be wired to the DTC in the same manner as the other HOA switches. After the device is installed, the computer will interlock these circuits with the ventilation such that they remain deenergized until after a preset purge time. The computer will deenergize these circuits again at the end of the occupied time. The HOA switch should remain locked in the automatic mode after the device is installed. Provide a minimum of one HOA switch for each burner room and crawl space; (two total) for the 19F5 or 19F5A; provide one for each 19F3 or 19F3B building (four total); (one total) for the entire 19F1A or 19F1B building. The key operated feature of this switch should prevent accidental changing of the position and the key should only be in the possession of the senior person in the instructor's station. The positions of this switch function are as follows:

(1) Hand - The fans must be operating for a preset time of 3 minutes before the power and lighting circuits noted above can be energized from this position. Prior to the installation of the trainer device, this position is used to provide light and power for construction and testing work in the crawl space. After installation of the trainer, this position can be used to provide utilities for normal maintenance work or to provide power and lighting in the event of a computer malfunction.

(2) Off - Power and lighting circuits deenergized.

(3) Automatic - The computer starts the purge cycle by operation of the ventilation fans and checks the sensors in the crawl space and central cabinets containing propane piping prior to energizing the power and lighting circuits. The exact sequence and timing of this operation is completed by NTSC at the time the trainer device and the computer are installed. The switch will

MIL-HDBK-1027/1

then be locked in the automatic position.

b) Crawl space shall contain propane burners, piping, valves, and regulators. As discussed above, the ventilation system will be interlocked with the main propane valve. Propane will not be introduced to the trainer until the crawl space is purged. In addition, the crawl space will contain propane detectors (provided by the device contractor) which will prevent the introduction of propane if 10 percent of the Lower Explosive Limit (LEL) of propane is detected in the crawl space or burner rooms.

c) The electrical receptacles, lighting fixtures, and other electrical equipment in crawl space and burner rooms shall normally be deenergized and can be energized only after the above interlocks are satisfied. These receptacles, lighting fixtures, and other electrical fixtures normally deenergized by interlocks should be designed for a Class I, Division 2, Group D hazardous location. Other electrical equipment, such as damper motors and unit heaters, in the crawl space and burner rooms which operate in absence of interlocks and when the ventilation system is secured should be designed for a Class I, Division 1, Group D hazardous location.

d) The crawl space exhaust fan and power enable controls shall include the following features:

- (1) Detect fan run status via a differential pressure sensor.
- (2) Detect a closed damper (with fan running) via a differential pressure sensor.
- (3) Transmit the analog fan differential pressure to the device computer.
- (4) Turn off fan upon detection of failure or closed damper.
- (5) Indicate when fan fails to respond to a control action.
- (6) Latched fan start circuit in hand control mode (upon restoration of power after a failure, fan will be off).
- (7) Use the fan status in purge timer interlock with crawl space power. Timer interlocks shall be provided with adjustable settings from 0 to 30 minutes, and set at 3 minutes.
- (8) Indicate when crawl space power enable fails to respond to a control action.
- (9) Crawl space power indicator light.
- (10) Latched crawl space power enable circuit in hand control mode (upon restoration of power after a failure, crawl space power will be off).

MIL-HDBK-1027/1

3.6.5 Alarm for Loss of Electrical Power. (For all trainers.) Provide a battery backup annunciation and alarm at the 24-hour duty desk and the instructor's station which will activate in the event of an electrical power outage at a trainer. Capability to silence the alarm shall be provided at both locations.

3.7 Floors. There shall be five types of floors in a fire training device structure: a training floor, a staging floor, a crawl space floor, a maintenance floor, equipment floor, and a computer room floor. Consider Occupational Safety and Health Administration (OSHA) requirements for walking surfaces. Floors shall be designed for a floor loading of 60 lb/ft² (17.2 kg) except for the computer area, which shall use standard computer floor design, and the deck surrounding the fireplace of the 19F4 and 19F4A. Additional support shall be provided by the device contractor to mount any equipment which exceeds the indicated loading.

3.7.1 Training Floor. The training floor is the floor inside the fire compartment that the trainees walk on. This floor shall be steel grating to give sure footing, good distribution of ventilation air which comes from below, and instant removal of firefighting agents. Unburned propane can be introduced into the compartment during flame suppression; therefore, even distribution of ventilation air is important to dilute it and flush it away. This floor shall be supported from the crawl space floor below and the walls. Grating shall be made of mild steel with a maximum vertical depth of 1 inch (25.4 mm) and holes that are 3/4 inch (19.05 mm) by 2 inches (50.8 mm) maximum, from centerline to centerline. The benefits of high temperature steel grating material is not cost effective in the firefighting facilities. A nonskid surface shall be provided on the grating. The grating shall be sectionalized and securely fastened so it can easily be removed for maintenance. Two men should be able to handle each section. The training floor shall meet the following additional criteria:

a) Floor support steel should be indirectly attached to the walls and crawl space floor to allow room for thermal expansion.

b) The areas designated as fireplace locations shall be free of lights, equipment, flooring, and floor support members. The perimeter of the fireplace area shall be designed, as shown in Appendix A, Figure A-9, to support the future device mockup around its perimeter. The fireplace support shall be 2-3/4 inches below the trainer floor. Since this area will remain open until the device contractor installs the mockup, a temporary post and chain railing shall be provided around the perimeter.

3.7.2 Crawl Space Floor. The crawl space floor shall be located directly under each training floor. Each crawl space floor shall be at or above grade for safety reasons. It should be constructed of concrete. The functions of the crawl space floor are to collect agents which come through the training floor grating, to separate training compartments in the case of two-story structures and provide a platform for the maintenance of burner and sensor equipment. The crawl space floor shall have chamfers where the walls meet the floors. The

MIL-HDBK-1027/1

cants shall be 6 inches high and 6 inches wide.

a) Where the crawl space floor meets any wall, provide a 6 inch high by 6 inch wide cant strip, fillet or curb. The purpose of this cant strip is to prevent propane gas from accumulating in the corners of the floor or wall interface. The cant strip will allow the propane gas to flow away from the walls.

Caution: Wastewater piping leading from a crawl space shall be routed to a separation chamber prior to discharging into the piping leading to the equalization tanks to prohibit the migration of propane in the piping. The separation chamber shall be provided as shown on Figure A-16 of Appendix A.

b) There shall be 4-1/2 feet (1.37 m) of clear space between the structure of the training floor and the crawl space floor, unless noted otherwise. This area shall remain clear of obstructions to allow for burner tubes and burner equipment. The perimeter of the crawl space should be as open as possible for burner tube installation and access to ventilation air. However, for Heating, Ventilating, and Air Conditioning (HVAC) equipment placement, ductwork, and piping runs in the crawl space, shall be limited to a space 24 inches wide above the louvers, along the exterior wall. Space in front of the crawl space louvers shall not be used, since it is the path of the ventilation air. In addition, the heated supply air duct for cold weather trainers can be located outside.

c) Personnel access shall be provided to crawl space areas. Ground level accesses shall be ramped to facilitate dolly traffic.

3.7.3 Staging Floor. The staging floor is the area where the students are organized before starting a firefighting sequence. The staging floor can be made of concrete or grating. The concrete design should have generous slopes to channel away water and collect it for treatment. If the area is exposed to the rain, the collection piping should be configured to allow rainwater to bypass the treatment system. The staging floor shall be designed to meet the following additional criteria:

a) A catchment shall be provided by each trainee door to ensure that the agent used by the trainee to cool the door is directed to the treatment system. Rainwater shall be handled as stated above.

b) When the staging area is above a fireplace compartment, as in the case of roof staging, the flooring must be separated from the heat generated in the space below. Galvanized steel grating shall be provided in these areas. The grating floor shall be at least 1 foot 8 inches above the concrete ceiling of the fireplace compartment. This concrete ceiling shall be sloped to drains located above each fireplace compartment.

MIL-HDBK-1027/1

c) Trench drains shall be provided.

3.7.4 Maintenance Floor. The maintenance floor is used in the electrical rooms and shall be constructed of concrete with no covering.

3.7.5 Computer Floor. The computer floor is a raised computer deck conforming to MIL-F-29046. Twelve inches of clear space shall be provided under the decking. This flooring shall be used in the instructor's station(s). The adjacent electrical room does not require a raised computer deck.

3.7.6 Grating Floors and Platforms. For grating floors and platforms located outside, provide galvanized steel grating with a non-skid surface.

3.8 Walls. The walls around the training compartments shall resist thermal cycling from 1,000 degrees F (538 degrees C) in the fire area to the coldest ambient temperature at the site, plus the effect of cold water applied during the extinguishment of the fire. The walls shall not be porous because, in colder climates, the wetted wall could be damaged when the water freezes. The walls shall withstand the mechanical stress of a stream of high-pressure water.

3.8.1 Wall System. The walls directly behind the cable raceway, electrical panel, trash can, storage compartment, and dryer fireplaces shall not have columns in them and the crawl space directly below shall also be free of columns. Holes up to 2 ft² (0.18 m²) will be cut through the walls in these areas by the device contractor. Holes any larger will be structurally reinforced by the device contractor.

The wall system for the training compartments shall be a reinforced, lightweight concrete with a 2-inch thick refractory coating of sprayed on calcium aluminate cement. In addition, the walls surrounding the fireplaces shall be lined with a steel panel. The panel and its supports should allow for thermal expansion. Weathering steel (ASTM A588, Standard Specification for High-Strength Low-Alloy Structural Steel With 50 psi (345 MPa) Minimum Yield Point to 4 in. (100 mm) Thick or ASTM A242, Standard Specification for High-Strength Low-Alloy Structural Steel) shall not be used because the rust is not self-limiting in this application. The steel liners protect the refractory coating from the effects of the water spray and raise the training compartment temperature by reflecting the heat back into space.

a) The refractory coating shall be a medium weight castable refractory (70 to 100 lb/ft³) with the following:

(1) An additive to promote moisture release during rapid increases in temperature

(2) Stainless steel Type 304 wire fibers, 1 inch long by 0.02 inch diameter

MIL-HDBK-1027/1

(3) Type 304 stainless steel, 10 gauge, wire fabric on 3 inch by 3 inch centers.

b) The expansion control joints for both walls and ceiling refractory coating shall contain a ceramic fiber blanket capable of withstanding a minimum of 2,000 degrees F.

A NAVFAC Guide Specification regarding the refractory lining system is under development by LANTNAVFACENCOM and will include detailed specifications and recommended sketches.

3.8.2 Windows. Windows shall be provided in training compartment walls as shown on the floor plans in Appendix B, Figures B-3 and B-4; Appendix C, Figures C-2 and C-3; Appendix D, Figures D-1, D-2, and D-3. These windows provide a means for spectator viewing. Windows should be 1-1/2 ft², (0.138 m²) be made of heat strengthened glass, and have hinged, sheet metal covers on the outside.

3.8.3 Cool Down. The walls adjacent to the fireplaces will probably overheat, so a method to cool them down between training exercises shall be provided. The preferred method is a water spray system consisting of nozzles and a motorized valve wired back to the data terminal cabinet, which will have manual control. The motorized valve shall have a manual bypass which will be used for the trickle cooling flow control. The nozzles shall be located so that water dripping from them will not detract from the training. These nozzles and their piping will require an adjustable flow rate of water to maintain a trickle to protect them from the heat.

3.9 Roofs and Ceilings

3.9.1 Training Compartment Ceilings. The ceilings in the training compartments shall be constructed of reinforced, lightweight concrete with a refractory coating of sprayed on calcium aluminate cement. No alternates are acceptable. When a steel false ceiling is required, it is to help control trainer compartment heat and to protect the refractory coating.

3.9.2 Staging Area Roofs. The roofs over the staging areas shall protect the trainees from the elements, such as the hot sun in the south and the snow in the north. Staging areas should have a roof.

In those structures where the roof access enters the fireplace compartment directly, the access way shall be shielded to impede the escape of hot gases. The shield shall be constructed of steel plate which shall form a rectangular box. The box shall surround the inclined ladder. The bottom edge of the box shall stop 6-1/2 feet (1.98 m) above the training floor in compartments 1 and 2 of the 19F1A and 9 feet (2.7 m) above the floor in the 19F3-B1 structure. The forward side of the box shall be far enough in front of the ladder so a person descending the ladder cannot bump his head. The shield shall be airtight where it meets the ceiling.

MIL-HDBK-1027/1

3.10 Instructor's Station and Electrical Space. Each 19F series trainer has its own instructor's station which, along with the adjacent electrical space, houses most of the electronic equipment associated with the device. Operations of the buildings associated with a given device are controlled from the instructor's station. A single point ground plate is required for trainers. The grounding plates are required in the instructor's station and its accompanying electrical room under the raised computer room flooring.

3.10.1 Air Conditioned Space. The instructor's station and adjacent electrical space should be designed as an air conditioned office. When the instructor's station is adjacent to a training compartment, it should be thermally insulated from it, including structural members.

3.10.2 Temperature and Relative Humidity. Environmentally control the instructor's station and the adjacent electrical room to 78 degrees F (25.5 degrees C) and 50 percent relative humidity in the summer and 68 degrees F (20 degrees C) and 30 percent relative humidity in the winter. Wintertime humidification and reheat for summertime dehumidification is not a requirement. In accordance with NAVFAC MIL-HDBK-1012/1, Electronics Facilities Engineering, dehumidification should not be provided in the air conditioning unit for an electronic equipment space. The instructor's station and adjacent electrical room shall be individually controlled by independent thermostats.

3.10.3 Fire Protection. A fixed, fire protection system is not required for the instructor's station or the adjacent electrical space. However, portable CO₂ extinguishers shall be provided by the facility contractor. Refer to paragraph 4.4 for the requirements of portable CO₂ extinguishers.

3.10.4 Window Glass. The window glass size and location shall be as indicated in the specific device sections. Glass shall be the insulated, shatter-resistant type. The bottom of the window shall be 3 feet (1.2 m) above the floor.

3.10.5 Plugged Tap. Each instructor's station will have pressure indication for the firefighting water supplied to the structure. A 1/2-inch (12.7 mm), plugged tap shall be provided on the fire water main close to the instructor's station. It's location should be clearly indicated on the drawing. The tap will provide the pressure signal to the gauges in the instructor's station.

3.11 Ventilation

3.11.1 General. The facility exhaust system serves three main functions:

- a) It continuously purges the structure of unburned fuel;
- b) It provides the secondary air necessary for complete combustion and realistic fire characteristics; and
- c) It collects the products of combustion for possible treatment.

MIL-HDBK-1027/1

The ventilation air shall be induced into each building by the exhaust fans. Provide air test ports throughout the system for testing and balancing. The burner rooms shall be ventilated to control the heat buildup and to cool the room for summer temperature control.

3.11.2 Purge. Purging of the facility exhaust system shall meet the following criteria:

a) Ambient air shall enter the building through louvers in the crawl space perimeter. When there is a burner room adjacent to the crawl space, the crawl space perimeter shall be left open to the burner room and the louvers located in the burner room exterior wall. The building design shall allow free air movement in the burner room and crawl space and prohibit the possibility of any stagnant air spaces where unburned fuel could accumulate. The fuel is heavier than air and could create an explosive situation if not flushed away.

b) Purge air shall flow at the full design rate.

3.11.3 Flushing. The ventilation system shall run continuously while the building is occupied and each compartment damper shall leak a minimum of 1,000 cubic feet per minute (cfm) when in its minimum position. This air is to maintain continuous flushing of spaces during the time when the fireplaces are not in use. In some cases, this flushing air quantity will be substantially higher depending on the turn down capability of the fan(s). Since simple static pressure devices can turn a fan down to approximately 50 percent, flushing air alone should never be more than that.

3.11.4 Combustion Air. The exhaust system shall deliver sufficient air to allow complete combustion. In the case of propane, it takes 23 parts of air for each part of fuel for theoretical complete combustion. The device burners do not provide any primary air therefore combustion air must be provided by the facility ventilation. In addition, enough excess air must be delivered to provide realistic flame characteristics. When a fuel is burned in the open, the flame induces into it approximately 10 times the air needed for perfect combustion. The trainer must be capable of providing this air to produce a natural looking fire. This excess air should enter the compartment at low velocity and not be directed at the flame.

3.11.5 Exhaust. The exhaust system shall be designed to conform to the following criteria:

a) Once inside the compartment, the air shall be heated, collected at the ceiling, ducted to a common point then to the exhaust fans and then to the treatment if necessary. The duct and fan layout shall allow for the future addition of a pollution control device. Every attempt should be made during the design of the structure to ensure that air is collected and leaves the structure through the exhaust system. Minimize leaks. The roof entries provide another escape path for the products of combustion and must be ducted into the exhaust system through manual dampers.

MIL-HDBK-1027/1

b) Each training compartment shall have a separate duct to carry away the products of combustion.

c) The exhaust stack shall be designed to have a height of 1.4 to 2.0 times the training structure height, which would eliminate short circuiting and contamination of fresh air entering the trainer. The stack shall be designed to meet the American Conference of Governmental Industrial Hygienists (ACGIH), ACGIH 2080, Industrial Ventilation, A Manual of Recommended Practice.

d) A low velocity area shall be provided prior to the exhaust fan inlet to allow the PKP particulate to settle out. The duct system shall have provisions for cleaning out the PKP particulate which will settle out. Access doors and low velocity areas shall be used in long horizontal runs and at the base of vertical runs. Provide a 2-inch trapped drain in the duct section.

3.11.6 Dilution Air. Dilution air shall be required to protect the compartment environment from a buildup of products of incomplete combustion, unburned fuel, and heat. Air specifically for dilution is not needed. This requirement is satisfied by secondary air.

3.11.7 Equipment

3.11.7.1 Louvers. Louvers shall run continuously around the perimeter of crawl spaces. They shall be sized for a maximum pressure drop of 0.1 inch (2.54 mm) W.G. at the design "air in" flow and be a minimum of 18 inches (457.2 mm) high. Louvers should be of corrosion-resistant material and designed so they can be removed individually for maintenance. Louvers shall be designed to meet the following additional criteria:

a) Perimeter louvers shall be provided with backdraft dampers which pivot on weather-and corrosion-resistant bearings. Dampers must operate freely year-round or the pollution abatement scheme will be jeopardized. These backdraft dampers are necessary to keep the wind from blowing straight across the crawl space. This wind could overpower the exhaust fan and pull products of combustion down and out through the crawl space.

Exception: Backdraft dampers for the 19F3/19F3B-B3, 19F3/19F3B-B4, 19F4, and 19F4A trainers are not required.

b) In areas where snow accumulation can be expected on a regular basis, the design of the louver system should prevent drifting snow from blocking the openings.

Caution: The structure must never be operated with any portion of the louver openings blocking the free entrance of air. Unburned propane could easily build to the LEL in pockets if ventilation is impeded.

MIL-HDBK-1027/1

c) In climates where the annual heating degree days are greater than 2,000 degrees F (1,143.1 degrees C), perimeter louvers shall be provided with motorized dampers. The motorized dampers allow the crawl space to be closed during the unoccupied hours so it can be maintained above freezing.

3.11.7.2 Dampers. Where more than one compartment is connected to the exhaust fan system, the air from each duct shall be controlled by a motorized, modulating, floating point damper from the instructor's station. In the "automatic" mode, the damper shall be controlled by the device computer. In the "hand" mode, the damper shall be controlled by an open-stop-close pushbutton set. The damper shall be capable of infinite positioning in either mode of operation. The dampers shall be designed for operation at 750 degrees F.

a) Motorized dampers connected to the DTC in the instructor's station shall be provided with a positive feedback control. Damper position status shall be provided in the instructor's station. Floating point dampers shall be provided with a modulating control output and the two position dampers shall have binary control. See Appendix A, Figures A-14 and A-19.

b) Motorized variable inlet guide vanes or variable speed motor shall be provided for the primary fan in each system, so the fan can be economically turned down during periods of no fire. This control would operate from reduced flushing flow to fully open when directed by the device computer. Any control used shall have the following requirements:

(1) The modulation controls shall have positive feedback and interface with the DTC.

(2) The exhaust fan controls shall provide means to indicate in the instructor's station the following status:

- Fan on-off condition
- Damper position
- Fan modulation - rpm (only if variable speed control is used)
- Alarm air temperature
- Exhaust air temperature

(3) The exhaust system shall be provided with safety warning signs to indicate personnel hazard from heat of ducts.

c) When only one compartment is connected to a fan, consideration should be given to letting these variable inlet guide vanes replace the motorized, duct damper. This provides a more dramatic reduction in part load horsepower and better control than can be obtained with duct dampers.

d) A manual damper shall be located in the duct leading from all compartments so the maximum exhaust flow from that space can be limited.

e) The dampers shall be designed for high temperature operation at

MIL-HDBK-1027/1

750 degrees F.

f) The dampers shall be electrically operated and shall be installed in the exhaust ductwork outside of the training compartment.

g) The dampers shall have a quick opening and closing time. The maximum time of operation of the dampers from any position to another position shall be 15 seconds.

3.11.7.3 Fan. The exhaust system for each building must be sized to pull approximately two times the "air in" rate due to volumetric expansion of the heated air. These values are listed in Table 1 entitled "Main Ventilation Air for Fireplace Compartment" for each structure. Design temperature for flow calculations shall be 600 degrees F (315.5 degrees C). The design temperature for materials shall be 750 degrees F (399 degrees C). The fan and the exhaust system shall meet the following criteria:

a) The exhaust system shall consist of at least two fans totaling 100 percent of the ventilation requirement. The exhaust system shall be designed for operation at 750 degrees F and shall be provided with high temperature expansion joints suitable for operation at 750 degrees F in lieu of flexible duct connectors. The exhaust system ductwork shall be constructed of stainless steel. Carbon steel should not be used because of high temperatures; the corrosion rate is increased and its structural strength is reduced due to the segregation of carbon.

b) Several factors should be considered in the selection of a fan type. The fan horsepower and energy consumption should be as low as possible. The motors for the exhaust fans should be sized for the lowest outside ambient temperature. The fan must also be able to ride the fan curve to 50 percent of its design flow rate without adverse effects.

c) Noise is a consideration. A fan should be chosen for quiet operation and located in a sufficiently remote area so as to not interfere with training.

d) Manually adjustable inlet dampers shall be provided for flow adjustment and segregation for maintenance.

e) Provide pressure drop indication across each fire compartment exhaust fan. The analog indication signal shall be routed to a remote indicator in the instructor's station and then to the DTC. In addition, a pressure switch(es) shall be provided which will sense the differential pressure across each fire compartment exhaust fan. The switch shall have an adjustable setpoint that when reached will shut off the fan and send a binary signal to the DTC. The setpoint should be chosen to indicate impending fan surge or to ensure that the ductwork will not implode. If the airflow is restricted too much, the switch will stop the fan before equipment is damaged.

MIL-HDBK-1027/1

Table 1
Main Ventilation Air for Fireplace Compartment
of 21C12 and 21C12A Structures

PROPANE DEMAND ft ³ /min	VENTILATION AIR OUT AT 600 degrees F ft ³ /min
203	73,000

- Notes: 1. Fan static pressure should be determined by comparing two modes of operations:
- a. During burner operation: bring 60 degrees F air through the louvers and exhausting 600 degrees F air through the exhaust system.
 - b. Between firefighting scenarios (burners off): bring 60 degrees F air through the louvers and exhausting 60 degrees F air through the exhaust system.
2. The fan motor shall be sized for bringing the lowest ambient air temperature expected through the louvers and exhausting it at the same temperature.

3.11.8 Control. Control of the ventilation shall be performed as follows:

- a) Before the start of training each day, the ventilation system will be energized with motorized dampers open and doors closed (in those structures with doors) to purge the structure of any unburned fuel which may have accumulated overnight. The purge should last at least 3 minutes.
- b) When treatment equipment is required, a ventilation system control scheme must be provided to satisfy the device requirements discussed above, plus the treatment equipment in an economical manner.
- c) Any motorized airflow adjustment device shall be controllable by the device computer. It is anticipated that the dampers will be simply controlled by a two-position signal interlocked with the fireplace(s) in its compartment; the fans will run continuously or be off if not needed for extended periods of time; variable inlet vanes will be fully open when any fire is on and positioned for flushing airflow when fires are off. The floating point motors are for future sophistication.

MIL-HDBK-1027/1

d) To prevent back spin during startup of the exhaust fans, provide the following:

(1) Individual controls for each fan and have it interfaced with the DTC.

(2) Each fan shall have a floating point motorized damper at the fan inlet. The damper shall remain closed until the fan is started.

3.11.9 Preheat. In extreme climates where the annual heating degree days is greater than 2,000, the ventilation air will require preheating. In trainers where the trainee walks into the path of the ventilation air, such as, bilge, berthing, or trash can fires, the air must be preheated. Where the trainee does not walk in the air path, as in the pit fire, the preheat temperature can be reduced for energy savings. The air passing through the burner rooms in extreme climates should be preheated. The preheating system shall meet the following criteria:

a) The heating equipment should be sized to heat the design airflow from the low ambient design temperature to 50 degrees F (10 degrees C). (This temperature was chosen because the heating design temperature is at night and only occurs during a small percentage of the time. Such a system would provide 60 degrees F (16 degrees C) air 95 percent of the time.)

b) The design of the preheat system shall not compromise the crawl space purge requirement. The preferred preheat system is to heat outside air and to distribute the air over the louver, motorized damper, and backdraft damper combination in the crawl space. The air should be heated from outside ambient temperature to a temperature hot enough to allow a mixed air temperature of 50 degrees F. Mixed air is comprised of cold outside air from the louver combination units and hot air from the preheat system. The preheat system shall be designed to heat the ventilation air by adequately mixing the air coming from louver combination units and the preheat system when the fire compartment exhaust fans are either exhausting 600 degrees F (315.5 degrees C) air (burners operating) or 50 degrees F air (burners off).

3.11.10 Other Rooms

3.11.10.1 Burner and Electrical Rooms. Some training structures have separate burner and electrical rooms. These rooms shall be provided with filtered ventilation air which can be discharged directly to the outside, separate from the facility ventilation system. The fans in these rooms shall run continuously while training is being conducted in that portion of the building. The control for this system should be by an HOA switch wired to the DTC. When there is no propane burner in the electrical room, the ventilation is for summer heat removal and should be controlled by a local wall switch in parallel with a thermostat. This ventilation does not apply to air conditioned electrical rooms associated with the instructor's station. Doors for the electrical rooms shall be 4 feet wide.

MIL-HDBK-1027/1

3.11.10.2 Escape Trunks. Escape trunks shall be provided with an exhaust fan located just below the roof hatch. This wall mounted fan should be wired to the DTC in the instructor's station so that anytime the escape trunk becomes too hot for training, the instructor can activate the fan. The exhaust fan for the escape trunk shall be thermostatically controlled and shall interface with the DTC.

3.11.11 Safety

3.11.11.1 Fuel Sensors. The ventilation shall be designed to eliminate the possibility of any accumulation of unburnt fuel. Because fuel settles in low unflushed areas, careful crawl space and facility ventilation design can preclude this. To monitor this condition, the device includes fuel sensors located in the crawl space and in the electrical rooms which contain burners. These sensors sample their immediate location for fuel in excess of a percentage of the LEL. If an excess is registered, they shut down the control console in the instructor's station and sound an alarm. These sensor systems, installed by the device contractor and maintained by the using activity, should be located in strategic places.

Caution: The sensors and ventilation system must be kept in good working order to prevent an incident.

3.11.11.2 24-Hour Propane Alarm. If the trainer is not in operation and 24-hour propane sensing is in effect, a means for remote alarm activation shall be provided (by device computer) at the DTC. Any alarms or other indicators are the responsibility of the facility contractor. The DTC will be the interface where the facility contractor will receive the 24 Vdc continuous signal.

3.11.11.3 Fan Interlock. Another level of safety shall be provided to prevent the danger of accumulated unburned fuel in the trainers. The danger from accumulated unburned fuel in the trainer during the occupied period can be adequately eliminated by a system of ventilation fans, sensors, and interlocks. During the unoccupied periods the risk is reduced by natural ventilation and the proper operation of the purge fan. Proper operation during the occupied periods requires flushing the crawl space prior to energizing the crawl space electrical circuits. The crawl space electrical circuits therefore, shall be interlocked with the main exhaust fans. At least one fan must be operating during the maintenance period before training. The fans and dampers as interlocked in the sequence in paragraph 3.11.10.1 shall be further interlocked to include a timer relay to energize the electrical circuits after a 3-minute delay from the key operated HOA switch. The timer relay will alleviate the human error of energizing the crawl space electrical circuit prematurely. Refer to Appendix A, Figure A-20.

3.11.11.4 Insulation or Shielding. Where exhaust ducts pass from one fire compartment into the occupied space of another, they shall be shielded or insulated or otherwise outfitted to ensure that personnel cannot be burned. If

MIL-HDBK-1027/1

insulation is used, its jacket must be able to withstand the heat and force of a hose jet.

3.12 21C12 and 21C12A Structures

3.12.1 General. The 21C12 and 21C12A structures will be used to provide hands-on practical firefighting, training for submarine personnel. The structure is designed to train a class of 25 students and can train 10 classes each week operating 8 hours a day.

3.12.2 Siting. On some projects, the 21C12 and 21C12A will be combined with the 21C6, submarine damage control trainer. Criteria for the 21C6 device is maintained by NTSC in Orlando, Florida. The 21C6 may only be physically attached to the 21C12 and 21C12A trainers at the bulk storage room. However, access to the bulk storage room via ramp and truck platform is required. Other exterior walls of the 21C12 and 21C12A must remain exposed to the outside.

3.12.3 Architectural. The floor plans for the 21C12 and 21C12A structures are provided in Appendix G.

3.12.3.1 Layout. The 21C12 and 21C12A structures shall consist of one fireplace compartment containing three fireplaces. The compartment is accessed from staging areas on either side through a submarine watertight door. There are two submarine doors in the 21C12 and 21C12A structures. All three fireplaces will be able to run simultaneously.

Mechanical Equipment Room: A 2500 ft² (floor area) mechanical equipment room shall be provided as a second floor above the bulk storage area.

3.12.3.2 Fireplace Compartment. The fireplace compartment shall meet the following criteria:

a) One wall shall simulate a curved bulkhead. There shall be two 10-foot lengths of bulkhead, 12 1/2 feet high with a curve radius of 15 feet supported by ribs. Bulkheads shall be spaced 15 feet apart. Each bulkhead shall have 3 support ribs spaced 3 feet (0.9 m) apart. Ribs shall be T-shaped, 10 inches (25.4) mm high with an 8-inch (20.3 mm) top and constructed of 1/4-inch (0.64 mm) steel plate. Bulkheads and ribs shall be made of steel in accordance with ASTM A36, Structural Steel. The wall ribs will be insulated by the device contractor to give a submarine-like appearance. The wall on the opposite side shall be a vertical wall because it is hidden from the trainees by a 7-foot high (2.1 m), steel partition. This partition shall contain two Emergency Air Breathing (EAB) outlets located in 304 stainless steel housings which will shield the EAB outlets from the fires. The EAB outlet housings are designated as "EO" in Appendix G. The emergency corridor is behind this partition. The corridor is not part of the training compartment and therefore does not have to retain a submarine-like appearance. Provide a 4-inch high steel kickplate around the edge of the training floor by the mockups and fireplaces at the grating floor as shown in Appendix G, Figure G-1. The

MIL-HDBK-1027/1

kickplate should minimize the trainee's feet from slipping into the mockups and fireplaces.

b) The short masonry walls opposite the partition shall support the SHS1 hose station and EAB cabinets. The main walkway and the emergency corridor floors shall be concrete while the 4-foot (1.2 m) wide walkways leading to the fireplaces shall be steel plate. One foot below the training floor shall be a grating equipment floor which shall be continuous under the mockup. The mockups will be mounted on the grating equipment floor. Mockups shall be located within 3 inches (76.2 mm) of steel walkway to preclude someone from getting their foot caught in the void. The device contractor will provide a personnel safety barrier between the mockups to prohibit a person from falling onto the grating equipment floor.

c) The construction contractor does not have to provide a temporary railing around the walkway since the grating equipment floor will be only 12 inches (304.8 mm) below. A chain railing shall be provided by the construction contractor around the bilge fireplace.

3.12.3.3 Crawl Space. There shall be a crawl space below the grating portion of the training compartment which maintains a 4-1/2-foot (1.37 m) clear space between the equipment floor and the floor of the crawl space. The concrete crawl space floor shall be approximately 5 feet (1.5 m) below the equipment floor. The crawl space shall extend below the fireplace compartment and part of both staging areas as shown on Figure G-1 of Appendix G. Refer to the floor plans in Appendix G for additional details.

3.12.3.4 Staging Areas. The staging areas shall be at the training floor elevation and shall be made of concrete. Each staging area shall include 1 combined SHS1 and SHS3 hose station, 1 EAB cabinet, 2 Oxygen Breathing Apparatus (OBA) canister racks, 10 OBA cabinets, 1 shower with hot and cold potable water, 1 water cooler, and doors leading to the outside and the bulk storage area. A portion of the staging area will be set aside for the storage of the many fire extinguishers required during training.

a) Hose drying in the 21C12 and 21C12A shall be provided in the staging areas. Hose drying consists of naturally drying the hoses on the staging area floor between training classes.

b) The staging areas shall be enclosed at the sites. No artificial smoke will be introduced into the staging area. Because of the fireplace compartment ventilation, its artificial smoke should never drift into the staging area.

3.12.3.5 Burner Room. Directly behind fireplaces shall be a burner room. Across from each burner is the computer electrical cabinet which operates it. The bilge fire burner will be located in the crawl space.

3.12.3.6 Bulk Storage

MIL-HDBK-1027/1

a) Directly adjacent to the staging areas shall be a bulk storage area with the same floor elevation as the staging area floors. This storage space will take bulk deliveries of consumables, store them, and prepare them for use. The extinguishers will be passed between staging and bulk storage, refilled, and returned for use. There should be at least enough extinguisher bottles for three classes.

b) The bulk storage room shall include an extinguisher fill station capable of replenishing CO₂, PKP, and AFFF extinguisher bottles. A truck platform shall be provided for receiving bulk materials. The configuration shall suit the type of packaging expected for the consumables for a given site. Refer to Section 4 for characteristics of CO₂, PKP, AFFF, and their systems.

3.12.3.7 AFFF Fill Station. The foam fill station for the 21C12 and 21C12A structures shall consist of a mixing tank, measuring tank, pump, water supply, spill containment, and drain. Foam concentrate will be delivered in 55 gal drums. A single 10 gpm (37.8 L³) low head pump shall be piped to pump concentrate from the drum to the 10 gal (37.8 L) measuring tank and supply the extinguisher's fill hose. The concentrate shall then flow to the mixing tank by gravity. Water shall be supplied to the 300 gal (1,135.5 L) mixing tank through an open sight funnel. The mixing tank shall have a closed top with a hinged cover, liquid level sight glass, and drain located at the bottom of the tank. A restricted bypass shall ensure that there is flow through the pump during extinguisher fill operations when the trigger fill nozzle is closed. Mixing of the solution shall be done manually.

a) Hoses 1/2 inch (12.7 mm) in diameter shall be provided for concentrate suction, solution discharge, and cold water washdown.

b) The fill station shall be provided with 120 psi (827.3 kPa) shop air to supply the propellant charge for the extinguishers. This air shall not be supplied from the EAB system compressor but from a separate 120 psig shop air compressor. Each AFFF extinguisher takes 2 L of air at 100 psi (689.4 kPa) for a full charge. The compressed air supply for the AFFF extinguisher fill shall be sized for a minimum airflow of 5 scfm (0.14 cu m/min) at 120 psig. Piping, a means for filling the extinguishers, and a suitably sized air receiver shall also be provided.

c) The entire foam fill station shall be surrounded by a containment to collect spills. Ramps shall be provided for access to the containment. Floor drains shall be provided in the containment and in two sites in the bulk storage area where filled bottles will be stored. A room designated as an extinguisher washdown room shall be located adjacent to the fill station. The AFFF fill station shall be in accordance with Appendix G, Figure G-10.

d) The EAB and AFFF fill compressors are sources of loud noise and vibration and shall be located to minimize noise and vibration interference with training. Noise control for these compressors shall be provided.

MIL-HDBK-1027/1

3.12.3.8 CO₂ Extinguisher Fill Station. A CO₂ extinguisher recharging station shall be provided for the 21C12, 21C12A, 19F5, and 19F5A structures. The recharging system shall consist of low-pressure refrigerated bulk storage tank and system with CO₂ at 0 degrees F (-17.8 degrees C) and 300 psig (2,068.2 kPa), and a manual extinguisher fill pump. See Appendix I, Figures I-1 through I-7 for CO₂ details.

3.12.3.9 Repair Lockers. Repair lockers are not required for the 21C12.

3.12.3.10 Ceilings. The ceiling in the fireplace compartment shall be 8 feet (2.4 m) above the training floor and constructed of grating hung from the roof. Access to the space above the ceiling shall be provided. The roof shall be a minimum of 12 feet (3.66 m) above the training floor.

3.12.3.11 Doors. Doors in the training structure shall be 1-3/4 inches (44.45 mm), hollow, metal doors unless indicated otherwise. The submarine doors between the staging areas and the training compartment shall visually simulate the watertight door on a SSB(N) 616 Class Submarine. However, the door shall retain only those functions which are necessary for firefighting training. The submarine door shall be mounted in a steel frame bulkhead, located in the concrete wall of the fireplace compartment. Provide stainless steel grip rails with non-slip surface above the submarine doors, on both sides of the walls. Also provide support plates for smoke curtains at the submarine doors in the trainer compartment. The device contractor shall provide the smoke curtains. A support and door stop should be provided to secure the submarine door when in the open position. The submarine door shall be as shown on BUSHIPS Dwg. 805-1400064.

The submarine door shall be specified as follows:

- Watertight Quick-Acting (WTQA)
- 316 stainless steel material
- 15 psi test pressure
- Right-hand or left-hand operation
- 18 inch x 36 inch size
- Lever operation - 6 rotating dogs on frame

3.12.3.12 Fireplaces. The exact dimension of the burn areas are:

<u>FIRE TYPE</u>	<u>DIMENSIONS</u>
a) Bilge/ Oil Spray Combination Fireplace	10 x 4 ft (3.04 x 1.22 m) 5 x 2 ft (1.52 x 0.61 m)
b) Hull Insulation Fireplace	15 ft wide x height of bulkhead (mounted between bulkheads)

MIL-HDBK-1027/1

- c) Electrical Panel 1 x 4 ft (0.30 x 1.22 m)
Fireplace

The bilge fireplace will be in the equipment floor of the training compartment. The hull insulation fireplace, oil spray fireplace, and electrical fireplace will be openings in the burner room wall. The oil spray fireplace will penetrate the curved bulkhead or wall behind the bilge fireplace.

3.12.3.13 Instructor's Station. A space 22 by 20 feet shall be provided as a combined instructor's station, electrical, and maintenance room. A raised computer floor shall be provided throughout, with 12 inches (304.8 mm) clear space below the raised floor. Lightweight partitions will be added by the device contractor. These partitions will not support any device equipment without having additional bracing provided beneath the raised floor. There shall be no windows in the instructor's station. The instructor's station shall be heated and air conditioned.

3.12.3.14 Miscellaneous. Artificial smoke will be introduced in the training compartment only. There will be no artificial smoke in the staging areas or in the emergency corridor.

3.12.4 Mechanical

3.12.4.1 Use Rate. The utilities for the 21C12 and 21C12A structures (refer to Table 2) are designed to support ten 4-hour classes of 25 students each week (2 classes per day). A class will be divided equally into two groups. Each group will go to a staging area and remain there for the class duration. Fires will be fought by the teams separately and simultaneously. However, only one fire hose will be used at a time since a majority of submarine firefighting is done with portable extinguishers. Table 2 will train 250 students per week, 1,000 students per month, and 11,000 trainees per year.

3.12.4.2 Firefighting Agents. The 21C12 and 21C12A training structures shall contain four hose stations, two stations are the combined type and the other two stations are the individual type. Each of the two combined hose stations shall consist of hose stations SHS1 and SHS2. The combined hose stations are located in the staging areas. The two individual hose stations are SHS1 and SHS2 and are located in the fire training compartment. The hose stations shall be served by one 1-1/2-inch (38.1 mm) angle-globe valve. Provide a bronze end hose cap with the angle-globe valve for thread ends. The valve shall have male hose threads at the cap connection. The angle-globe valve shall be perpendicular to the wall and shall be served by piping routed in or through the wall. Refer to Section 4 regarding the details of the hose stations.

Fifteen-lb CO₂, 18-lb (8.2 kg) PKP, and 2-1/2-gal (9.46 l) AFFF extinguishers will also be used. Since the use rate for the extinguishers will be high, ready storage is located in the staging area. After beneficial occupancy, the instructors will locate the extinguishers in the trainer compartment.

MIL-HDBK-1027/1

Table 2
21C12 and 21C12A Structures

 CLASS SCHEDULE

SHIFT	MON	TUE	WED	THU	FRI
Morning	D	G	J	M	P
Afternoon	E	H	K	N	Q
Evening	F	I	L	O	R

- Notes:
1. Table shows trainer time only, not classroom time.
 2. Classes, 20 students each, are designated as D through R, inclusive.
 3. Time is designated as 4 hours in the morning, 4 hours in the afternoon, and 4 hours in the evening.
-

 PROPANE USAGE

CLASS OF FIRE	NO. OF FIRES/ CLASS (25 STU)	FIREPLACE TYPE	PROPANE DEMAND ft ³ /min	PROPANE USE PER FIRE (cfm)	TOTAL PROPANE ft ³ /CLASS
A	12	Hull insulation	105	315	3,780
B	12	Bilge/Oil Spray	88	264	3,168
C	12	Electrical	<u>10</u>	<u>13</u>	<u>150</u>
	36 Fires per class		203 CFM		7,098 ft ³ / class; 194 gal/class

- Notes:
1. Propane demand is based on a gas pressure at the bilge and hull fires of 2 psi.
 2. The design propane demand for the building is 203 CFM.
 3. It was assumed that although there are more fires in the 0011 course they do not burn as long; therefore, the total consumption 7,098 ft³ (198.74 m³)/class, based on the 0010 course, is the design maximum.

MIL-HDBK-1027/1

Table 2 (Continued)
21C12 and 21C12A Structures

AGENT USAGE

NO. OF FIRES/ <u>CLASS</u>	NO. OF HOSES/ <u>FIRE</u>	<u>WATER</u>			WATER/4 HOUR <u>CLASS gal</u>	
		<u>WATER gpm</u>	<u>WATER TIME/ FIRE min</u>			
36	1	40	6		7,200	
NO. OF FIRES/ <u>CLASS</u>	PKP BOTTLES/ <u>CLASS</u>	<u>EXTINGUISHERS</u>				
		<u>PKP CLASS/ lb</u>	<u>AFFF BOTTLES/ CLASS</u>	<u>AFFF CLASS/ gal</u>	<u>CO₂ BOTTLES/ CLASS</u>	<u>CO₂ CLASS/ lb</u>
45	6	108	25	63	25	375

- Notes:
1. Water is used at the design rate during an 0010 course fire.
 2. Extinguisher sizes are 18 lb, 2-1/2 gal, (9.46 l) 15 lb (6.8 kg) for PKP, AFFF, and CO₂ respectively.
 3. AFFF indicated is a 6 percent solution.
 4. Extinguishers are used at the design rate during an 0011 course fire.
 5. PKP extinguishers will use 40 CO₂ charges per class.
 6. Though water is used for firefighting, extinguishers are the primary method for fighting fires on submarines.

TOTAL UTILITIES

	DAILY	WEEKLY	MONTHLY
Propane	21,300 ft ³ (596.4 m ³)	106,000 ft ³ (2.968 m ³)	355,000 ft ³ (9,940 m ³)
Water	21,600 gal (81,756 L)	72,000 gal (272,520 L)	180,000 gal (681,300 L)
AFFF Concentrate (100%)	9 gal (34.06 L)	42 gal (159 L)	135 gal (511 L)

MIL-HDBK-1027/1

Table 2 (Continued)
21C12 and 21C12A Structures

TOTAL UTILITIES (Continued)

	DAILY	WEEKLY	MONTHLY
PKP	342 lb (155 kg)	1,620 lb (735 kg)	5,400 lb (2449 kg)
CO ₂	1,125 lb (509.6 kg)	5,250 lb (2,378.3 kg)	16,875 lb (7,644.4 kg)

- Notes:
1. Daily rates assume three 4-hour classes in the trainer a day.
 2. Weekly rates for water assume (10)-0010 and five -0011 classes a week; for extinguishers, assume five -0010 and (10)-0011 classes a week.
 3. Monthly rates assume (25) 0010 and (25) 0011 classes.
 4. AFFF Concentrate (100 percent) is 20 percent AFFF, 80 percent water.

Caution: Any extinguisher located inside the training compartment must be shielded from fires. If it were exposed to the radiant heat, pressure inside the extinguisher could build to unsafe levels.

3.12.4.3 Ventilation for 21C12 and 21C12A Structures. Ventilation for the 21C12 and 21C12A structures shall conform to the following criteria:

a) The design ventilation for the 21C12 and 21C12A shall be based on the simultaneous operation of all three fireplaces or 73,000 cfm "air out." The minimum ventilation shall be 1,000 cfm (28 m³) in the training compartment.

b) The training compartment shall have a 13-inch (330.2 mm) diameter ventilation duct which will be used for training purposes. This duct shall run above the main walkway and terminate with a cap above the ceiling in staging area 1. The other end shall lead to the fan room above staging area 2. There shall be a bulkhead flapper at both staging area wall penetrations. An 8-inch (203.2 mm) branch leading to the fire area shall be fitted with an 8-inch female blower adapter to allow the trainees to connect a Red Devil Blower. The blower will be used to aid in evacuating smoke from the space during the training exercise. The bulkhead flappers and blower adapter will be provided by the

MIL-HDBK-1027/1

device contractor. The horizontal run and the elbow in staging area 2 shall have access panels for cleanout. Device contractor will provide the Red Devil blower and adapter.

c) In the fan room, the trainee vent duct shall connect to the main compartment exhaust system through a motorized damper and a manual damper. During a training scenario when the trainee secures the mockup compartment ventilation, the motor damper will close automatically, stopping the flow of smoke into the branch duct. Note the actual compartment ventilation shall be unaffected. It will run continuously. When the trainee attaches the Red Devil Blower to the branch duct and reactivates the trainer ventilation, the motor damper will reopen, discharging into the main exhaust duct.

d) The main ventilation system for the fireplace compartment shall have intakes above the ceiling level at the bilge and hull fireplaces, above the entrance to the emergency corridor at the ceiling level at the bilge and hull fireplaces, above the entrance to the emergency corridor at the ceiling level, and at the roof level above the emergency corridor door leading to staging area 2. Each of the intake ducts shall have manual dampers for volume control. The main ventilation system shall be provided with a floating point damper in the main exhaust duct run serving the fireplace compartment.

e) The main ventilation system duct work shall be oversized as follows:

(1) The main duct run shall be sized for 100 percent of the fireplace compartment ventilation.

(2) The intake and ductwork for each of the two fireplaces, bilge and hull, shall be sized for 100 percent of the fireplace compartment ventilation. The manual damper for each of the two intakes shall be set to exhaust 29,200 actual cubic feet per minute (acfm) ($817.6 \text{ m}^3/\text{min}$) at 600 degrees F (316 degrees C) of exhaust gases.

(3) The intakes and ductwork for the roof level and emergency corridor exhaust point shall each be sized for 25 percent of the fireplace compartments ventilation. The manual damper for each of the two intakes shall be set to exhaust 7,300 acfm ($204.4 \text{ m}^3/\text{min}$) at 600 degrees F of exhaust gases.

(4) Ventilation exhaust equipment and systems shall be designed and selected for continuous operation at 750 degrees F.

3.12.4.4 Air Conditioning and Heating. The electronic equipment in the instructor's station is expected to add 38,354 Btu/hr (11,237.7 W/hr) to the air conditioning load. This can be broken down into 22,626 Btu/hr (6,629.4 W/hr) in the operator station and 15,728 Btu/hr (4,608.3 W/hr) in the electrical room. Design for five people in the instructor's station rooms. One staging area shall be heated during the unoccupied times. It will be designated as a hose drying area where wet hoses can be stored until the next training session.

MIL-HDBK-1027/1

3.12.4.5 Cooling Spray. Cooling spray nozzles shall be located above the grating ceiling aimed to direct water on the mockups. The single water supply pipe leading to the nozzles shall have a motorized valve with a manual bypass controlled from the DTC. The cooling will be activated between exercises whenever the training compartment becomes too hot. The cooling system will not be part of the training scenario. Each cooling spray nozzle shall have a constant dripping of water to cool the compartment walls. Refer to paragraph 3.8.3.

3.12.4.6 Breathing Air. Two types of breathing apparatus are used in the 21C12 and 21C12A structures, the OBA and EAB devices. The OBA canisters for this structure shall be racked in accordance with Appendix G, Figure G-5. There shall be two such racks in each staging area for a ready storage of 44 OBA canisters per team. The OBA headpiece shall be stored in lockers constructed in accordance with Appendix G, Figure G-7. There shall be 10 OBA lockers in each staging area. The EAB outlet housings shall be constructed in accordance with Mare Island Dwgs. 612-1889964A1 and 612-1889964A2, refer to Appendix G, Figure G-11. The housings shall have doors. There shall be six EAB outlet housings, four in the fireplace compartment and one in each of the two staging areas.

Caution: Care must be taken during design and construction of the breathing air system to eliminate any possibility of the air in the EAB system rising in temperature such that it would be hazardous to health. The EAB system piping shall not be routed in the fireplace compartment.

a) EAB head gear shall be stored in a cabinet in accordance with Appendix G, Figure G-6. Two cabinets shall be located in each staging area and two cabinets shall be located in the fireplace compartment.

b) The EAB system shall be in accordance with the schematic shown on LANTDIV Sketch No. SK-M-43-86. The EAB system shall be a 100 psig (689.4 kPa) system. Naval Facilities Guide Specification, NFGS-15403, Nonflammable Medical Gas Systems, on nonflammable medical gas systems can be used; however, the guide specification must be modified to suit the requirements of this 21C12, 21C12A criteria.

c) The EAB system shall meet: (1) Fed. Spec. BB-A-1034, Source II and (2) 29 CFR 1910, OSHA Safety and Health Standards for General Industry Grade D breathing air requirements. Delete reference to Table II. The EAB compressor shall be an oil-free, breathing air compressor: single-stage, positive displacement, non-pulsating, and liquid ring type, Nash Engineering Company, Model OC-5C or equal. To meet the breathing requirements, the EAB system may require the use of a refrigerated air dryer and a high purity air filter/cleaner. The fresh air intake to the EAB compressor shall be located away from any potential air contamination sources.

d) Air samples taken from the completed system shall be tested and

MIL-HDBK-1027/1

approved in accordance with: (1) Fed. Spec. BB-A-1034, Source II and (2) 29 CFR 1910 Grade D breathing air requirements prior to system acceptance and twice per year. The EAB system is not required to be certified per Naval Material Command (NAVMAT) P-9290, System Certification Procedures and Criteria Manual for Deep Submergency System.

3.12.5 Electrical

3.12.5.1 Power. The power requirement for the device will be 35.5 kVA. It shall be 120/208 Vac, three-phase, 60 cycle and include 21.4 kVA in the burner room and 14.1 kVA in the instructor's station.

There shall be two heavy duty type electrical outlets in the training compartment located on the edge of the main walkway. One outlet shall be 480-Vac, three-phase, 60 cycle and the other shall be 120-Vac, single-phase service.

3.12.5.2 Lighting. The 21C12 and 21C12A structures parking lot and grounds shall be lighted for nighttime operation. The training compartment shall be lighted for maintenance from underneath the grating.

The emergency egress corridors shall be lighted with low wall fixtures located to be shielded from the fires. Locate switches on both sides of the emergency exit doors. These lights will only be used for maintenance purposes so that the lights will not interfere with training.

The device contractor will provide training compartment lighting which is remotely controlled from the instructor's station.

3.12.6 Propane Alarm System. The firefighting training facility will have a 24-hour propane detection system in the trainers. The detection system will be provided by the device contractor and monitored by the device computers.

The facility contractor is required to interface with the detection system via a DTC and an alarm system. The facility contractor shall provide the following:

- a) A DTC for the trainer, refer to paragraph 2.5.3.2.
- b) An alarm system with audible alarms, warning lights (backlighted signs), and manual pull stations.

The alarm system shall be wired to the DTC and shall consist of the following: (Refer to Appendix G, Figure G-17 for the alarm system schematic.)

3.12.6.1 Central Control Panel. Provide a central control panel at the quarterdeck or 24-hour duty station. The panel shall be wired to the DTC, shall be UL listed, and shall have indicating lights indicating the source of

MIL-HDBK-1027/1

alarm from the DTC, auxiliary control stations, and manual pull stations.

a) Provide manual control on the central control panel for actuating and deenergizing the audible alarms and warning signs.

b) The DTC shall be capable of energizing and deenergizing the alarm system.

c) The central control panel with the appropriate label shall contain connections for future propane to the fire department.

d) A propane alarm condition can be actuated by the DTC, manual pull stations, the central control panel, or the auxiliary control stations. The alarm condition can be deenergized only by the DTC, central control panel, or the auxiliary control stations. The audible alarms can be deenergized only by the auxiliary control stations.

e) In the event of an alarm condition, the appropriate warning signs, audible alarms, and the DTC shall be alarmed by the central control panel.

3.12.6.2 Audible Alarms. Provide audible alarms at the following locations:

- a) Classrooms and offices
- b) Locker rooms and restrooms
- c) Storage rooms
- d) Staging and training areas
- e) Quarterdeck or 24-hour duty station
- f) Main corridors and vestibules
- g) Mechanical and fan rooms
- h) Propane storage areas

3.12.6.3 Propane Warning Signs. Provide separate propane warning signs at the following locations:

- a) Front entrance
- b) Loading dock
- c) Quarterdeck or 24-hour duty station
- d) Instructor and operator station

MIL-HDBK-1027/1

e) Propane storage area

The warning signs shall be the backlighted type and shall flash when there is an alarm condition. The propane warning signs shall state "DANGER - PROPANE ALERT."

3.12.7 Manual Pull Stations. Provide separate manual pull stations which actuate an alarm condition at the following locations:

- a) Outside propane tank storage area
- b) Mechanical rooms

3.12.8 Auxiliary Control Stations. Provide auxiliary control stations which consist of manual pull stations. Auxiliary control stations shall be capable of deenergizing the audible alarms. Provide auxiliary control stations at the following locations:

- a) Instructor and operator station
- b) Quarterdeck or 24-hour duty station

3.12.9 Intercom System. Provide an intercom system to include the following:

a) Audible alarms shall override the intercom system until the alarms have been secured. When the audible alarms have been secured, the intercom system shall be operable. Intercoms shall not be provided in the fireplace compartments, crawl space, and burner rooms.

b) The intercom system shall have public announcement capability with speakers located in all rooms of the facility, except as noted above.

3.13 19F1A and 19F1B Structures

3.13.1 General. The 19F1A and 19F1B structures will be used to train the Advanced Shipboard Firefighting Team Evaluation Course, J-425-0424. The structure is designed to train an 0424 class of 30 students and can train two classes or 60 students each week operating a single shift.

3.13.2 Architectural. The floor plans for the 19F1A and 19F1B structures are in Appendix B.

3.13.2.1 Layout. The 19F1A and 19F1B structures contain eight training quadrants on two floors accessible by a centrally located corridor. Staging will be done on the upper level. The structure, including the corridor, will be divided in half by a smoke tight wall allowing for separate and independent training to proceed simultaneously. To better control the products of combustion, the second floor crawl space floor shall also be smoke tight. The corridor walls and the escape trunk enclosure shall be continuous from the crawl

MIL-HDBK-1027/1

space floor to the concrete ceiling over the training compartment. Provide ventilation openings at the base of these corridor enclosures on three walls. Personnel access to the space below the corridor floor should be by removing a grating section.

Except for the aforementioned walls, the crawl spaces shall remain open and clear. Partition walls shall stop at the training floor. Grating shall be used exclusively for the training floors in the 19F1A structure.

3.13.2.2 Ceilings. A steel barrier or false ceiling should be provided in Compartments 1 and 2 below the second floor crawl space to facilitate the buildup of residual heat so the room stays hot during the whole exercise. The ceiling shields the crawl space floor above from direct radiant heat, keeping it cooler. A clearance of approximately 12 inches (304.8 mm) shall be maintained between the barrier and the walls.

3.13.2.3 Doors and Hatches. The door type shall be as shown on the floor plan. Exterior doors on the first and second training levels are for emergency use only. Their location may be shifted to accommodate structural requirements. Hollow metal doors shall be used for non-training doors for identification purposes. During search and identification classes, the trainee will be instructed to use only watertight doors.

a) Access to the first floor from the second floor shall be through a horizontal large hatch. These hatches are to be located between floors instead of on the roof because the roof location would require the roof to be 8 feet (2.44 m) wider. Also the hatch will get hotter located between floors which is a plus for training.

b) The heat shield for the Ellison door is a definite requirement, however, the shield restricts access to Compartment 1 from the escape trunk. For trainee safety, the bilge fire will be programmed to be off, or in the low fire position, in that corner during escape trunk training so the trainees can walk in that area of the fireplace.

3.13.2.4 Fireplaces. The exact dimensions of the burn areas are given in Table 3 incrementally by compartment.

3.13.2.5 Enclosures

a) The enclosure in Compartment 4 is designed to complicate the training associated with the cable raceway fire. The enclosure shall be 7 feet by 7 feet (2.13 m by 2.13 m) and shall have 8.5-foot (2.59 m) high steel walls, a grating floor, a wire mesh door, and no ceiling. The raceway fireplace will be located 7 feet (2.13 m) above the floor and will be installed by the device contractor who will cut the necessary holes in the steel walls.

MIL-HDBK-1027/1

Table 3
Dimensions of Burn Areas for 19F1A and 19F1B Structures Figures

COMPARTMENT	TYPE	SIZE
Compartment 1 19 x 19 ft (5.79 x 5.79 m)	Bilge Fire	2 rectangular areas 5 x 12 ft, 2 x 5 ft (1.5 x 3.66 m, 0.61 x 1.5 m)
	Oil Spray	2 x 5 ft above bilge
Compartment 2 19 x 19 ft	Bilge Fire	2 rectangular areas 5 x 10 ft, 5 x 10 ft
	Obstruction	3 x 6 ft (3 ft H) (0.91 x 1.83 m (0.91 m H))
Compartment 3 15 x 18 ft (4.57 x 5.49 m)	Clothes Dryer	6.5 ft H x 4-1/2 ft W x 40 in. D (1.98 m H x 1.4 m W x 1,016 mm D)
	Electrical Panel	1 x 4 ft (Note 1) (0.34 x 1.22 m)
	Obstruction-Laundry Table	2.5 x 5 ft 2.5 ft H (0.76 m x 1.5 m (0.76 m H))
Compartment 4 15 x 18 ft (4.57 x 5.47 m)	Deep Fat/Stack Hood	2 x 5 ft (Note 1)
	Wire Bundle (Cable Raceway)	10 x 1.5 ft (Note 1) (3 x 0.46 m)
Compartment 5 15 x 19 ft (4.57 x 5.79 m)	Radar Display Console	2 x 3 ft (0.61 x 0.91 m)
Trash Can	6 X 6 ft	(1.83 x 1.83 mm)
	Escape Trunk (No exit)	5 x 5 ft (1.5 x 1.5 m)
Compartment 6 15 x 19 ft (4.57 x 5.8 m)	Weapons Fire Enclosure	7 ft x 7 ft x 8 ft H (2.13 m x 2.13 m x 2.44 m H)
	Storage Room	7 ft x 7 ft x 8 ft H

MIL-HDBK-1027/1

Table 3 (Continued)
Dimensions of Burn Areas for 19F1A and 19F1B Structures Figures

COMPARTMENT	TYPE	SIZE
Compartment 7 15 x 18 ft (4.57 x 5.49 m)	Mattress Fire	7 x 3.5 ft (2.13 x 1.07 m)
	Locker Fire	3 x 3.5 ft (0.9 x 1.07 m)
	"Dummy" Mattress Mockup	7 x 3.5 ft
Compartment 8 15 x 18 ft	Motor Generator	3 ft x 4 ft; 3 ft off each wall (0.9 x 1.22 m)
	Vent Duct	12 x 2 ft (Note 1) (3.66 x 0.61 m)

- Notes: 1. No hole in floor is required for these fireplaces.
2. Dimensions for fireplace compartment sizes shall be clear dimensions. When compartments have refractory coatings and steel plate liners on walls, the inside clear dimension shall be from liner to liner.

b) There are two enclosures in Compartment 6. One encloses the storage room fireplace and the other is the weapons enclosure. The storage room shall be 7 feet by 7 feet (2.13 m by 2.13 m). The walls and door shall be steel frame with heavy chain link fence fabric sides. The walls shall be 8 feet high. No ceiling shall be provided. The floor will be a standard fireplace floor which means it will be open until the device is installed. Provide a chain inside the door to prevent entry until the floor is installed. The 7-foot by 7-foot (2.13 m by 2.13 m) weapons enclosure shall be 8-foot (2.44 m) high steel in front and adjacent to the storage room. No ceiling. Provide a watertight door. The floor shall have a fireplace floor perimeter, however, a temporary grating floor with associated temporary supporting structure shall be provided. The weapons fireplace or fire enclosure will be installed sometime in the future, therefore, a temporary floor is more appropriate than a drained entry.

3.13.2.6 Instructor's Station. The instructor's station shall conform to the following criteria:

a) The instructor's station should have two personnel doors and two windows with dimensions of 8 by 2-1/2 feet.

b) The instructor's station and electrical room below it shall be

MIL-HDBK-1027/1

10 feet (3 m) wide and air conditioned. Contractors must be cautioned to seal wall penetrations airtight. Note that other maintenance areas shall be ventilated only.

c) Provide a 5-foot (1.5 m) diameter circular stairway between the two floors. The stairway provides secondary access, is circular to save space, and is too narrow for equipment passage. The transferring of equipment can be accomplished by the exterior doors and stairs.

3.13.2.7 Miscellaneous. The following are additional architectural criteria pertaining to 19F1A structures:

a) Local OBA cabinets will not be used in the 19F1A structure. The OBA's will be stored in the repair lockers.

b) An escape trunk shall be provided in Compartment 1.

c) The inclined ladder leading to Compartments 1 and 2, and 3 and 4 descends greater than 14 feet (4.3 m), however, no intermediate landing is required. The inclined ladder shall be slip resistant.

d) The Foam Reel Station (FR) and halon systems between Compartments 1 and 2 shall be protected from the fire by 4-foot (1.22 m) high heat shields. The heat shields shall be constructed of pipe and sheet metal and be sized so radiant heat from the fire cannot reach the firefighting equipment.

3.13.3 Mechanical

3.13.3.1 Use Rate. The 19F1A and 19F1B structures are designed to house 13 distinct fireplaces to instruct a one-day course for two ship's teams of up to 24 members per team. The ship's teams are organized in port duty section fire parties, repair parties, rescue and assistance details and at-sea fire parties (average team size is 18). Each team will be assigned a building half for training. Each side of the building will have three training exercises per hour. Each team will fight a minimum of five fires with a sixth fire as the graded exercise for the course. The graded exercise for the team will be on the opposite building half from which the team trained. A typical schedule will train three classes (A, B, C) per week, 108 trainees per week or 5,400 trainees per year.

3.13.3.2 Firefighting Agents. The first and second training floors shall have HS1 type hose stations while HS2 hose stations shall be installed on the roof staging area. In addition, one Foam Hose Station (FS) and one FR type hose station for foam, shall be installed on the roof staging area. The FS by the escape trunk shall supply foam to the FR in Compartment 2 and to the FR on the roof. Provide six 15-lb (6.795 kg) CO₂ cylinders, four 30-lb (13.6 kg) PKP cylinders and one 20-lb (9.06 kg) PKP cylinder. These cylinders shall be provided by the construction contractor and located and installed by station personnel. Halon 1301 (device contractor installed) will be simulated in

MIL-HDBK-1027/1

Compartment 1 and a foam reel FR, shall be provided in Compartment 2. Foam will be used throughout the structure from hose reels and 5-gal (18.93 L) cans.

Provide a 1-1/2-inch (38.1 mm) fire water line to the deep fat fryer fireplace and terminate it with a globe valve below floor grating. The water will be used for APC extinguishing agent simulation.

For propane usage, agent usage and total utilities, see Table 4.

3.13.3.3 Ventilation

a) There shall be an exhaust duct leading from each compartment with a separately operated motorized floating point damper. These ducts should come together above the roof staging area and lead to the exhaust fan system. The collection duct can be as much as 8 feet (2.44 m) wide and the bottom shall be no closer than 7 feet (2.1 m) to the staging floor.

b) The design capacity of the exhaust fans shall be based on the simultaneous operation of compartments or 98,000 cfm (2,744 m³/min) "air out." For ventilation air per compartment, see Table 5.

c) The anticipated control is by device computer and is as follows: When a fire is initiated the building exhaust system will control from flushing to full design ventilation. The damper for the functioning compartment will open to a full design ventilation position. Dampers in nonfunctioning compartments will remain in their minimum flushing position.

d) Although smoke will not be admitted directly into the corridors, the roof entryways shall have an exhaust duct to capture any stray smoke. The duct shall discharge into the main exhaust duct through a manual damper.

3.13.3.4 Air Conditioning. Electronic equipment in the instructor's station is expected to add 18,000 Btu/hr (5,274 W) to the air conditioning load. Normal occupancy will be eight people. The electronic room below the instructor's station has an air conditioning load of 33,500 Btu/hr (9,815.5 W) due to equipment. Individual thermostatic control of each area is required.

3.13.4 Electrical. The power for the device shall be 75 kVA. Provide 120/208-Vac, three-phase service. Provide four lights for each training compartment switched by compartment. Locate a switch for each compartment by the closest crawl space door and another outside by the emergency door. These light fixtures shall be provided to light the training compartment by shining up. There shall be six lighting circuits per crawl space.

MIL-HDBK-1027/1

Table 4
19F1A and 19F1B Structures

FIRE CLASS	TIME	NO. OF FIRES
A	Wednesday AM	12 fires
	PM	12 fires
B	Thursday AM	12 fires
	PM	12 fires
C	Friday AM	12 fires
	PM	12 fires

PROPANE USAGE

CLASS OF FIRES	NO. OF FIRES/ GROUP (15 MEN) 2 DAYS	FIRE TYPE	PROPANE DEMAND ft ³ /min	PROPANE USE PER FIRE ft ³	TOTAL PROPANE/ GROUP FOR 2 DAYS
A	3	Trash Can	10	15	45
	3	Mattress/Locker	20	30	90
	3	Steam Clothes Dryer	10	15	45
	3	Storage Compartment	20	30	90
	3	Vent Duct	10	15	45
B	4	Bilge/Oil Spray (Note 1)	140	350	1,400
	4	Bilge (Note 2)	175	438	1,752
	3	Deep Fat Fryer/ Fryer Hood	20	30	90
C	1	Electrical Panel	5	7.5	7.5
	1	Motor Generator	10	15	15
	1	Radar Display	10	15	15
	1	Cable Raceway	10	15	15
Alternate	6	A, B, or C		30 - 438	2,000
	36 fires/group				5,610 ft ³ / group 153 gal/ group

- Notes: 1. Compartment 1.
2. Compartment 2.
3. There will be 12 fires per group, 24 fires per class, 72 fires per week.

MIL-HDBK-1027/1

Table 4 (Continued)
19F1A and 19F1B Structures

Notes: (Continued)

4. Propane demand is based on a gas pressure at the burner of 1 lb psi except for the bilge fires which are based on 2 psi.
5. The design propane demand for the structure is $140 + 175 + 20 = 335$ cfm.

AGENT USAGE

CLASS OF FIRE	NO. OF FIRES/ GROUP	NO. OF HOSES <u>1-1/2 in.</u>	WATER gpm	AFFF 6% gpm	PKP FIRE lb	CO ₂ FIRE lb	TIME min
A	15	2	70				3-5
B	8	1		95	10-20		8-10
C	4					2-15 lb Bottles	
Deep Fat	3	1	70		20		3-5
Alternate	6	1		95	20		

- Notes: 1. The bilge fires will be fought sometimes using AFFF and portable PKP bottles
2. The design water demand for the structure is $70 + 70 + 95$, or 235 gpm.

TOTAL UTILITIES

	DAY <u>3/</u>	WEEKLY	MONTHLY
Propane	11,000 ft ³	22,000 ft ³	2,400 gal
Water	44,000 gal	88,000 gal	352,000 gal
AFFF Concentrate (100%)	800 gal	1,600 gal	6,400 gal
PKP	500 lb	1,000 lb	4,000 lb
CO ₂	250 lb	500 lb	2,000 lb

- Notes: 1. The water category includes the water portion of AFFF (94 percent water, 6 percent AFFF for design).
2. 67 percent of the water usage occurs on Tuesday and Thursday.
3. Values listed equal two times the group rates for "19F1A Propane Usage" and "19F1A Agent Usage."
4. The monthly consumption equals four times the weekly values.

MIL-HDBK-1027/1

Table 5
19F1A and 19F1B Ventilation Air

COMPARTMENT	PROPANE DEMAND ft ³ /min	VENTILATION AIR OUT AT 600 degrees F ft ³ /min
1	140	25,300
2	175	31,300
3	10	4,600
4	20	9,200
5	10	4,600
6	20	9,200
7	20	9,200
8	10	4,600

- Notes:
1. The design ventilation is the sum of compartments or 98,000 cfm (2,744 m³/min) "air out." The minimum flushing ventilation shall be as low as the fans can turn down but never lower than 8,000 cfm (224 m³/min) "air in."
 2. Fan static pressure should be determined by bringing 50 degrees F (15.5 degrees C) air through the louvers and exhausting 600 degrees F (315.5 degrees C) through the exhaust system.

3.14 19F3 and 19F3B Structures

3.14.1 General. The 19F3 and 19F3B structures will be used to train the General Shipboard Firefighting Training Course, J-495-0412. The structure is designed to train an 0412 class of 108 students and can train three classes or 324 students each week operating a single shift. Approximately 15,500 students can be trained in a year.

a) The location of the four buildings of the 19F3 and 19F3B trainers are flexible; however, consideration should be given to clustering them around the instructor's station located in the bilge fire building, to minimize control wiring lengths. No building should be further than 60 feet (9.1 m) horizontally from the instructor's station.

MIL-HDBK-1027/1

b) Line of sight is not a requirement between the instructor's station and the pit fire buildings.

3.14.2 Architectural. The floor plans for the 19F3 and 19F3B structures are in Appendix C. The 19F3 and 19F3B devices are housed in four structures: the bilge fire building, the galley/berthing building, and two pit fire buildings.

3.14.2.1 Bilge Fire Building (19F3 and 19F3B). The bilge fire building shall have interior dimensions of 30 feet by 30 feet (9.14 m by 9.14 m) with a ceiling height of 15 feet (4.57 m). This area will house a generalized mockup of a shipboard engineering space to provide realism while exposing students to a major Class "B" bilge fire. Staging will be on the roof and at one ground level entrance. One topside entrance shall include a dogged watertight door built into a vestibule, leading to an inclined ladder. The ladder shall have a 5-foot (1.52 m) long landing midway down its length. At bilge area 1, the dimension from the corner to the shield must be 10 ft - 3 inch clear. At bilge area 2, the dimension from the corner to the escape truck liner must be 23 ft - 6 inch clear.

a) The bilge fire building shall have a second topside entrance by way of a watertight hatch and emergency escape trunk.

b) A ground level entry with staging area shall be located under the vertical ladder in the bilge fire building. The staging area shall include a 15-foot by 15-foot (4.57 m by 4.57 m) OBA locker with a ground level entry. The design of the OBA locker shall be similar to a repair locker.

c) A 4-foot (1.2 m) wide walkway shall be provided around the exterior of the building to allow for emergency egress and to allow exterior viewing of the training scenario. Two sets of stairs shall provide access to the roof.

d) A metal false ceiling shall be provided in the B1 building to facilitate the buildup of residual heat so the room stays hot during the whole exercise.

e) The perimeter dampers on the B1 building shall be 24 inches (609.6 mm) high.

3.14.2.2 Galley/Berthing Fire Building. The galley berthing building shall have interior dimensions of 30 feet by 30 feet (9.14 m by 9.14 m) and a ceiling height of 10 feet (3.048 m). It shall be divided in half with one half having mockups to represent a berthing space and having a weapons fire enclosure. The other half will contain a deep fat fryer fire, a cable raceway fire, and an electrical panel fire. Staging and access to the structure shall be from staging area at same level as training floor through watertight doors.

a) Provide a 1-1/2-inch (38.1 mm) process water line to the deep

MIL-HDBK-1027/1

fat fryer fireplace and terminate it in a globe valve under trainer floor. This water line will be used for APC extinguishing agent simulation.

b) A 4-foot wide walkway shall be provided around the exterior of the structure for emergency egress and viewing.

3.14.2.3 Pit Fire Building. The pit fire building shall be 31 by 25 feet and contain a 15-foot by 15-foot (4.57 m by 4.57 m) fireplace to teach basic firefighting techniques. The ceiling shall be 30 feet (9.14 m) above the training floor. A staging area shall be provided so the students enter the structure through a 20-foot wide by 12-foot high opening in the wall. No door is required.

a) The floor around the fireplace shall be steel plate with a non-slip surface. The floor shall slope to the fireplace so agents are channeled to the crawl space. The rear perimeter plate shall be 2 feet (0.61 m) wide. There is no training requirement for the decking on either side or to the rear of the B3 or B4 building.

b) The columns used to support the fireplace perimeter shall be located at each corner, one on each side in the center and two in the front and back on 5-foot (1.52 m) centers. A vertical barrier shall be provided around the perimeter of the fireplace to prevent water from getting beyond the perimeter.

c) The students will walk on the fireplace grating but this grating will be provided by the device contractor along with the weapon mockup ramp. When a device contractor supplied weapon mockup is indicated it will be stored inside the building.

3.14.2.4 Doors. Doors leading to the fire areas of the 19F3 and 19F3B structures shall be quick-acting watertight doors. The doors leading to non-fire areas shall be hollow metal doors. In the galley/berthing building, the door between Compartments 1 and 2 shall be watertight.

3.14.2.5 Fireplaces. The dimensions of specific fireplace locations are listed in Table 6.

3.14.2.6 Instructor's Station. An instructor's station shall be located on the roof of the bilge fire building and shall control the 19F3 buildings. The instructor's station shall be 12 by 24 feet. Directly below the instructor's station shall be an air conditioned electrical space. The window dimensions shall be 8 by 2-1/2 feet with the bottom 4 feet above the floor.

3.14.3 Mechanical

3.14.3.1 Use Rates

MIL-HDBK-1027/1

Table 6
Dimensions for 19F3 and 19F3B Structures Fireplace Locations

Bilge fire building B1	
2 rectangular areas:	7 x 8 ft; 4 x 17 ft (2.1 x 2.4 m), (1.2 x 5.2 m)
3 rectangular areas:	5 x 8 ft; 5 x 8 ft; 9 x 5 ft (1.5 x 2.4 m); (1.5 x 2.4 m); (2.7 x 1.5 m)
Obstructions:	2 ft x 10 ft x 8 ft high (0.6 x 3 m x 2.4 m H) 1 ft x 9 ft x 6 ft high (0.3 m x 2.7 m x 1.8 m H)
Pit fire building, B3:	15 ft x 15 ft (1.38 m x 1.38 m)
Pit fire building weapon, B4:	15 ft x 15
Galley/berthing building, B2	7 ft x 7 ft x 8 ft high (2.1 m x 2.1 m x 2.4 m H)
Mattress/locker fire	10 ft x 3.5 ft (3 m x 1.06 m)
Dummy mattress mockup	7 ft x 3.5 ft (2.1 m x 1.06 m)
Mattress/locker mockup	15 ft x 3.5 ft (0.6 m x 1.06 m)
Deep fat/stack hood	2 ft x 5 ft (Note 1) (0.6 m x 1.5 m)
Electrical panel	1 ft x 4 ft (Note 1) (0.3 m x 1.2 m)
Cableway	1 ft x 3 ft x 8 ft AFF (Note 1) (0.3 m x 0.9 m x 2.4 m AFF)

- Notes: 1. No hole in floor is required for this fireplace.
2. Dimensions for fireplace compartment sizes shall be clear dimensions. When compartments have refractory coatings and steel plate liners on walls, the inside clear dimension shall be from liner to liner.

MIL-HDBK-1027/1

a) The 19F3 and 19F3B structures are designed to house eight distinct fireplaces to instruct a 2-day course for a class of 108 trainees. The afternoon of the first day, the class is split into two groups of 54 students each. Each group goes to a deck fire building, B3 or B4, where it is further divided into two groups of 27. The first group is divided into four hose teams. All four hose teams fight the fire at one time. The second group of 27 is given lectures. Each group will receive a "dropped weapon" fire demonstration at the end of their deck fires. Once fires and demonstrations are completed for each group, the two groups on each building will rotate and repeat the lectures and fires.

b) The second day the class is divided into two groups of 54 students each. Each group then goes to either the B1 or B2 structure. In the B1 building the group is divided into two groups of 27 students. One group goes to the top level of B1 and one group goes to the bottom level of B1. The top group performs a vertical entry into the space and attacks the oil spray-bilge fire. The lower group will attack the prop shaft bilge fire alternately with the top level group. When both levels have completed fires, the groups alternate from the top to the bottom and bottom to the top and repeat. In the B2 building the group of 54 is also split into two groups of 27 each. The first group of 27 is then split into two groups and each attacks the mattress and metal storage locker fires together from two separate entrances until each member has fought a Class "Alpha" fire as a nozzleman. The second group of 27 fights the electrical panel and the wire bundle fires until each member has extinguished a Class "Charlie" fire. The second group will also watch a demonstration on the deep fat fryer and stack hood fire. Once both groups are finished with their first part of B2, they will alternate with the other group until all students have completed B2.

Until completion of each building, the group from B1 will go to B2 and the B2 group will go to B1 until all of the students have completed both buildings.

For propane usage, agent usage and total utilities, see Table 7.

3.14.3.2 Ventilation. (Refer to Table 8). Provide an exhaust outlet with a motorized damper in the ceiling above each bilge area and in each compartment. Ducts from one fireplace shall not run horizontally through the compartment of another fireplace. The design capacity of the exhaust fans for the B1, B2, B3, and B4 buildings shall be equal to the maximum building ventilation cubic feet per minute "air out."

3.14.3.3 Air Conditioning. Electronic equipment in the instructor's station is expected to add 26,620 Btu to the air conditioning load. Normal occupancy will be six people. The electrical room below the instructor's station has an air conditioning load of 24,240 Btu due to equipment. Individual thermostatic control is required for each area.

MIL-HDBK-1027/1

Table 7
19F3 and 19F3B Structures

CLASS SCHEDULE

BUILDING	MON		TUE		WED		THU		FRI	
	AM	PM	AM	PM	AM	PM	AM	PM	AM	PM
B1			X		Y		Z			
B2			X		Y		Z			MAINTENANCE
B3		X		Y		Z				
B4		X	X	<u>2/</u> <u>2/</u>	Y	Y	<u>2/</u> <u>Z</u>	Z		

Notes: 1. Day 1 AM, Classroom lecture
 2. Day 2 PM, Demonstrations
 3. Three classes: X, Y, Z

PROPANE USAGE

BLDG	CLASS OF FIRES	NO. OF FIRES/CLASS	FIRE TYPE	PROPANE DEMAND ft ³ /min	PROPANE USE PER FIRE/ft ³	TOTAL PROPANE/CLASS ft ³
<u>First Day PM</u>						
B3	B	30	Pit	394	591	17,730
B4	B	30	Pit	394	591	17,730
<u>Second Day</u>						
B1	B	13	Bilge Area 1	168	336	4,368
	B	14	Bilge Area 2	187	374	5,237
B2	A	9	Mattress/Locker	20	30	270
	B	9	Deep Fat Fryer/ Fryer Hood	20	30	270
	C	9	Elect. Panel	5	7.5	68
	C	9	Cable Raceway	10	15	135
B3 or B4	D	12	Pit/Weapon	394	591	7,092
Alternate		<u>9</u>	A, B, or C	187	374	<u>3,366</u>

144 fires/class

56,265 ft³
Class for
2 Days1,542 gal/
Class for
2 Days

MIL-HDBK-1027/1

Table 7 (Continued)
19F3 and 19F3B Structures

- Notes:
- Propane demand is based on a gas pressure at the burner of 1 psi except for the bilge and pit fires which are based on 2 psi.
 - The design propane demand for each building is:
 - B1 168 + 187 or 355 cfm
 - B2 20 + 20 or 40 cfm
 - B3 394 cfm
 - B4 394 cfm
 - The design propane demand for the four buildings together is: 355 + 40 + 394 or 789 cfm

AGENT USAGE

BLDG	CLASS OF FIRE	NO. OF FIRES/ CLASS	NO. OF HOSES 1-1/2 in.	WATER gpm	AFFF 6% gpm	PKP/ FIRE lb	CO ₂ / FIRE lb	WATER TIME min
<u>First Day PM</u>								
B3	B	30	2	125				3
B4	B	30	2	125				3
<u>Second Day</u>								
B1	B	27	1	95	95	25 ¹ / ₂		3
	B		1					1
B2	A	9	2	95				3
	B	9	1	95		7		3
	C	9					7.5	
	C	9					7.5	-
B3 or B4	D	12	2		125			1
Alternate		9	1	95				3
			1		95	10		1

- Notes:
- PKP will be used in 9 of the 27 fires in the B1 building.
 - The design water demand for each building is:
 - B1 (95 + 95) x 2 or 380 gpm (1,438 l/min)
 - B2 95 x 2 + 95 or 285 gpm (1,078.7 l/min)
 - B3 125 x 2 or 250 gpm (946.25 l/min)
 - B4 125 x 2 or 250 gpm
 - The design water demand for the four buildings together is: 380 + 285 + 250 = 915 gpm (3,463 l/min)
 - B1 will have nine fires/hour.
 - B2, B3, & B4 will have 15 fires/hour.
 - In B1 each team (12 men) will approach a fire from each of three entryways.
 - B1 fire heights 10 to 12 feet (3 m to 3.6 m).

MIL-HDBK-1027/1

Table 7 (Continued)
19F3 and 19F3B Structures

Notes: (Continued)

8. B2 fire heights 12 to 15 feet.(3.6 m to 4.6 m)
9. PKP and CO₂ in B2 will come from portable extinguishers; 9 CO₂ charges for PKP bottles required per class.
10. Each class will use 72 OBA canisters with each canister being used three times.
11. B3 will have foam provisions similar to B4 so they can be used interchangeably.

TOTAL UTILITIES

	<u>CLASS DAY 2</u>	<u>WEEKLY</u>	<u>MONTHLY</u>
Propane	56,000 ft ³	168,000 ft ³	18,360 gal
Water	70,000 gal (264,950 L)	210,000 gal (794,850 L)	840,000 gal
AFFF Concentrate (100%)	400 gal (1,514 L)	1,200 gal (4,542 L)	4,800 gal
PKP	400 lb (1,514 kg)	1,200 lb (4,542 kg)	4,800 lb
CO ₂	140 lb (63.4 kg)	420 lb (190.2 kg)	1,680 lb

- Notes:
1. The water category includes the water portion of the AFFF (94 percent water, 6 percent AFFF for design).
 2. 70 percent of the water usage for a class occurs on the first day of class. However, since the successive classes overlap, the design daily water consumption equals the values for one 2-day class.
 3. The monthly consumption equals four times the weekly values.

MIL-HDBK-1027/1

Table 8
19F3 and 19F3B Ventilation Air

BUILDING COMPARTMENT	PROPANE DEMAND cfm	VENTILATION AIR OUT AT 600 degrees F cfm	MAXIMUM BUILDING VENTILATION AIR OUT cfm
B1 Area 1	168	29,900	63,500
Area 2	187	33,600	
B2 Area 1	20	9,200	18,400
Area 2	20	9,200	
Area 3	5	2,300	
B3	394	120,000	120,000
B4	394	120,000	120,000

Note: Fan static pressure should be determined by bringing 60 degrees F air through the louvers and exhausting 600 degrees F through the exhaust system.

3.14.4 Electrical

a) Provide 120/208 V, three-phase service to each of the structures as follows:

B1 building 70 kVA
B2 building 37.5 kVA
B3 & B4 building 25 kVA each

b) Provide the following spare conduits from the instructor's station located at the of building B1 to B2, B3, and B4 buildings as follows:

B2 Building 3 - 3-inch conduit
B3 Building 3 - 3-inch conduit
B4 Building 3 - 3-inch conduit

The above conduits will be used by the device contractor for both power and control wiring. Power and control wiring shall be run in separate conduits.

3.15 19F3A and 19F3C Structures

3.15.1 General. The 19F3A and 19F3C structures will be used to train the General Shipboard Firefighting Training Course, J-495-0412; Advanced Shipboard Firefighting Evaluating Course, A-495-0419; and Advanced Shipboard Firefighting Team Training Course, J-495-0424. The structure is designed to train in a single shift an 0412 class of 60 students and can train up to four classes or

MIL-HDBK-1027/1

240 students each week; an 0419 class of 30 students and can train up to one class or 30 students each week; and an 0424 class of 30 students and can train up to two classes or 60 students each week. Splitting the year evenly, this trainer can teach 6,000 students the general course and 1,500 students the advanced team course annually.

3.15.2 Architectural. The floor plans for the 19F3A and 19F3C structures are in Appendix D.

3.15.2.1 Layout

a) The 19F3A and 19F3C structures are a single building which includes 19F1A and 19F1B type structures and 19F3 and 19F3B-B3 buildings connected by a large covered staging area. The respective portions of the 19F3A and 19F3C structures shall duplicate the 19F1A, 19F1B, 19F3, and 19F3B-B3 buildings with the exceptions presented herein.

b) Compartments in the 19F1A and 19F1B portions of the structure have been enlarged and the fireplaces have been relocated to accommodate the larger General Firefighting Course classes. The 0412 students will stage at ground level and in the adjacent compartments on the second floor. They will not travel between floors during a training scenario. Trainees in the 0424 course will travel between floors and a landing should be provided midway in the inclined ladder leading to Compartments 1 and 2. Doors leading from fireplace compartments in the 19F1A and 19F1B portions shall be watertight. Those used by the trainees shall be quick acting.

c) The pit fire, B3, or B4 portion is the same as for the 19F3 and 19F3B structures.

d) A 15- by 15-foot locker with an exterior access shall be provided for OBA storage and shall be designed as a repair locker. Standard OBA cabinets shall be provided in the OBA locker. A wild hose demonstration area is required for teaching in the 19F3A and 19F3C structures. Where the climate allows year around training outside, the wild hose demonstration area should be outside. Trainees would watch the demonstration from the open sides of the staging area. In severe weather locations, the wild hose area shall be provided in an area enclosed on three sides with the trainee side open. Means with unrestricted visibility shall be provided to protect the bleacher from the hose water spray (a Plexiglas barrier meets this requirement). Refer to paragraph 2.4.2. The water will come from the HS2 hose station on the opposite side of the staging area.

e) Bleachers will be required in the 19F3A and 19F3C structures and shall be capable of seating 120 people.

f) Demonstrations of portable extinguishers will be conducted on the B3 side of the staging area.

g) The staging area shall be constructed of concrete with

MIL-HDBK-1027/1

appropriate floor drains. If bulk dry storage is to be located underneath the staging area, then a waterproof construction must be used. Subsurface storage should not be considered where there is a high water table or where flooding is probable.

3.15.2.2 Doors and Hatches. The doors leading from Compartments 1 and 2 to the staging area shall be quick acting and watertight with 180 degree swing. The door leading to Compartment 2 shall be installed in a removable panel such that when the door and panel are removed a 3- by 7-foot minimum opening is available for the transfer of large equipment. The door will be used for installation and maintenance. A 6 foot wide, 7-foot high door shall be located in the staging area to accommodate large equipment on hand trucks. The door shall have a ramp access. Forklift truck access is not required.

a) The first floor burner room doors shall be located at each end of the burner rooms. They shall be exterior doors except for the northwest corner which shall be in the extended stair column. The second floor burner room doors shall be accessed from the stair columns as in the 19F1A.

b) A large hatch shall be provided at the top of the inclined stairs leading from the first floor and the second floor.

3.15.2.3 Fireplaces. For the exact dimensions of the fireplaces incrementally by compartment, refer to Table 9.

3.15.2.4 Instructor's Station. The instructor's station and the electrical room below the instructor's station shall be similar to the rooms of the 19F1A, 19F1B. The interior dimensions shall be approximately 44 by 10 feet. Controls for the pit fire, B3, or B4 portion shall be installed in the instructor's station.

3.15.2.5 Miscellaneous

a) No hose drying area is required but provide the following two items for hose drying: an outside hose drying rack and a heated storage for rolled up 50-foot long hoses. The rolled hoses should be stored vertically in storage racks. The racks should be designed to hold two rolls high and be located in the OBA locker.

b) P-250 training is a part of the 0412 course; therefore, a facility to teach it shall be a requirement whenever a 19F3A and 19F3C structures.

3.15.3 Mechanical

3.15.3.1 Use Rate. The utilities for the 19F3A and 19F3C structures (refer to Table 10) are designed to support four general classes of 60 trainees each week. During the first session, the class will go to the pit fire location. It will be divided into four hose teams of 15 trainees each. Two hose teams at a time will fight the fire alternately at a rate of 15 fires per hour.

MIL-HDBK-1027/1

Table 9
Dimensions for 19F3A and 19F3C Structures Fireplaces

COMPARTMENT	TYPE	SIZE
Compartment 1 25 x 20 ft	Bilge Fire, Oil Spray	2 rectangular areas 5 x 12 ft, 2 x 5 ft
Compartment 2 25 x 20 ft	Bilge Fire Obstruction	2 rectangular areas 5 x 10 ft, 5 x 10 ft 3 x 6 ft, (3 ft high)
Compartment 3 18 x 20 ft	Clothes Dryer Electrical Panel Obstruction-Laundry Table	6.5 ft H x 4.5 ft W x 4.0 ft D 1 x 4 ft (Note 4) 2.5 x 5 ft (2.5 ft high)
Compartment 4 18 x 20 ft	Deep Fat/Stack Hood Wire Bundle (Cable Raceway) Closet	2 x 5 ft (Note 4) 10 x 1.5 ft (Note 4) 4 x 6 ft
Compartment 5 25 x 20 ft	Escape Trunk (No exit) Weapons Enclosure Storage Room	5 x 5 ft 7 x 7 x 8 ft H 7 x 7 x 8 ft H
Compartment 6 25 x 20 ft	Mattress/Locker Fire "Dummy" Mattress Fire	10 x 3.5 ft 7 x 3.5 ft
Compartment 7 18 x 20 ft	Motor Generator Wall Vent Duct Enclosed Pit Fire	3 x 4 ft; 3 ft off each wall 12 x 2 ft (Note 4) 15 x 15 ft
Compartment 8 18 x 20 ft	Radar Display Console Trash Can	2 x 3 ft 6 x 6 ft

- Notes: 1. The Cable Raceway Fire will be mounted 8 feet above the grated floor and will be installed in an enclosure with 8 foot- 6 inch high walls.
2. Bilge Fire Heights - Maximum 9 feet.
3. Pit Fire Heights - 12 to 15 feet.
4. No hole in the floor is required for these fireplaces.
5. Dimensions for fireplace compartment sizes shall be clear. When compartments have refractory coatings & steel plate liners on walls, the inside clear dimension shall be from liner to liner.

MIL-HDBK-1027/1

Table 10
19F3A and 19F3C Structures

PORTION OF BUILDING	MON		TUE		WED		THU		FRI	
	AM	PM	AM	PM	AM	PM	AM	PM	AM	PM
Classroom	V	W				X		Y		
Pit Fire/ Demonstration		V	W					X	Y	
Bilge Fire				V	W				X	Y

- Notes:
1. The 2 day-course includes classroom session before fire training and a demonstration session after it.
 2. Demonstration will be in front of pit fireplace, therefore, during the second day, another class should not be using this area.
 3. Classes, 60 trainees each, are designated as V, W, X, and Y.

PROPANE USAGE

CLASS OF FIRES	NO. OF FIRES/ CLASS (60 MEN) 2 DAYS	FIRE TYPE	PROPANE DEMAND ft ³ MIN.	PROPANE USE PER FIRE ft ³	TOTAL PROPANE/ GROUP FOR 2 DAYS
First Day PM					
B	30	Pit	394	591	17,730
Second Day AM					
B	20	Bilge Compartments 1 & 2	175	438	8,760
B	32	Deep Fat Fryer/ Fryer Hood	20	30	960
A	24	Mattress/Locker, Trash Can, etc.	20	30	720
C	24	Radar Display, Elect. Panel, etc.	10	15	360
	130 fires/class				28,520 ft ³ /class 779 gal/class

- Notes:
1. Propane demand is based on a gas pressure at the burner of 1 psi except the bilge and pit fires require 2 psi.
 2. The design propane demand for the building is:
394 + 175 + 175 + 20 + 20 = 784 CFM

MIL-HDBK-1027/1

Table 10 (Continued)
19F3A and 19F3C Structures

AGENT USAGE

<u>CLASS OF FIRE</u>	<u>NO. OF FIRES/ CLASS</u>	<u>NO. OF HOSES 1-1/2 in.</u>	<u>WATER gpm</u>	<u>AFFF 6% gpm</u>	<u>PKP/ FIRE lb</u>	<u>CO₂/ FIRE lb</u>	<u>WATER TIME min</u>
<u>First Day PM</u>							
B	30	2	125				3
<u>Second Day AM</u>							
B	20	1	95				2.5
		1		95	25		1
B	32	1	95		7		3
A	24	2	95				3
C	<u>24</u>					7	-
	130						

- Notes:
1. PKP will be used in 7 of the 20 bilge fires.
 2. The design water demand is: $(125) 2 + (95 + 95) 2 + 95 + (95) 2 = 915$ gpm
 3. PKP and CO₂ used on the Fryer and Electrical fires respectively will come from portable extinguishers; 32 - CO₂ charges for PKP bottles will be required for each class.
 4. Each 0412 class will use 72 OBA canisters. Each canister shall be used by three students.

TOTAL UTILITIES

	<u>CLASS 2 DAY</u>	<u>MONTHLY</u>
Propane	28,000 ft ³	262,000 ft ³
Water	52,000 gal	627,000 gal
AFFF Concentrate (100%)	114 gal	5,600 gal
PKP	400 lb	5,800 lb
CO ₂	168 lb	2,700 lb

MIL-HDBK-1027/1

Table 10 (Continued)
19F3A and 19F3C Structures

-
- Notes:
1. The water category includes the water portion of the AFFF (94 percent water, 6 percent AFFF for design).
 2. 45 percent of the water usage for a class occurs on the first day of class. However, since the successive classes overlap, the design daily water consumption equals the values for one 2-day class.
 3. The greatest weekly consumption is four times that for a single class.
 4. The 2-day class totals are for a 0412 class.
 5. The weekly rate is four times the 2-day class rate.
 6. The monthly consumption includes seven 0412 classes and six 0424 classes.
-

a) During the second session this class will again be divided into four groups of 15 trainees. One group will go to Compartment 1, one will go to Compartment 2, one will go to Compartments 3 and 4, and one will go to Compartments 5, 6, 7, and 8. Each group will stay at a location for one hour then rotate to a different location. Each group will go to either Compartment 1 or 2 but not both.

b) The following utility rates will easily support the 0419 and 0418 courses because both have fewer fires per class. The 0418 course, when it is taught in the 19F3A and 19F3C, will be similar to when it is taught in the 19F1A and 19F1B. Only one course type can be taught in the 19F3A and 19F3C at any given time.

3.15.3.2 Firefighting Agents

a) There shall be a foam reel in Compartment 2 which shall get its foam from the FS on the east side of the roof and a FR between the Compartment 1 and 2 exterior doors. This second FR shall get its foam from the FS on the west side of the roof. The interior FR is fed from the east FS because both stations serve the same group during 0418 training. During 0412 training each FR will be served by a separate FS.

b) Provide six 15-lb (6.75 kg) CO₂ cylinders, four 30-lb (13.5 kg) PKP cylinders, and one 20-lb (9 kg) PKP cylinder. These cylinders shall be provided by the construction contractor and located and installed by the station personnel. Halon will be simulated in Compartment 1.

c) Provide a 1-1/2-inch (38.1 mm) process water line to the deep fat fryer fireplace and terminate it with a globe valve below the trainer floor

MIL-HDBK-1027/1

grating. This water line will be used for APC extinguishing agent simulation.

3.15.3.3 Ventilation. The design ventilation less the pit fire or the 19F1A, 19F1B portion of the structure shall be based on the simultaneous operation of compartments or 104,000 cfm "air out." The minimum ventilation shall be 8 by 1,000 or 8,000 cfm (22.65 m³/sec). The design ventilation for the pit fire, B3, or B4 portion of the structure shall be 120,000 cfm (339.72 m³/sec) "air out." For ventilation air per area, see Table 11.

3.15.3.4 Air Conditioning. The electronic equipment in the instructor's station is expected to add 23,000 Btu/hr to the air conditioning load. Normal occupancy will be six people. The adjacent electrical room will have an air conditioning load of 33,000 Btu/hr due to equipment and a two-person occupancy. Individual thermostatic control for each area is required.

3.15.4 Electrical

3.15.4.1 Power. The power for the device is 100 kVA. Provide 120/208 V, three-phase service.

3.15.4.2 Lighting. The staging area shall be lighted for training after dark. When walkways and stair columns associated with the 19F1A and 19F1B portions of the structure are enclosed, they shall be lighted.

Table 11
19F3A and 19F3C Ventilation Air

COMPARTMENT	PROPANE DEMAND ft ³ /min	VENTILATION AIR OUT AT 600 Degrees F ft ³ /min
1	175	31,300
2	175	31,300
3	10	4,600
4	20	9,200
5	20	9,200
6	20	9,200
7	10	4,600
8	10	4,600
Pit	394	120,000

Note: Fan static pressure should be determined by bringing 60 degrees F (15.6 C) air through the louvers and exhausting 600 degrees F (315.6 C) through the exhaust system.

MIL-HDBK-1027/1

3.16 19F4 and 19F4A Structures

3.16.1 General. The 19F4 and 19F4A structures will be used to train the Shipboard Aircraft Firefighting Course, J-495-0413 and the Aviation Facility Ship Helicopter Firefighting Team Training course, J-495-0414. The structure is designed to train two 2-day 0413 classes of 60 students and one 1-day 0414 class of 30 students a week. Approximately 6,000 students can be trained a year.

3.16.2 Architectural. The floor plans for the 19F4 and 19F4A structures are in Appendix E.

3.16.2.1 Layout. The 19F4 and 19F4A structures are designed to simulate aircraft fires onboard ship. It consists of an open training deck measuring 112 by 66 feet with one fireplace. The training deck shall be constructed of concrete. The fireplace shall be 52 by 36 feet centered leaving two 30-foot wide and two 15-foot wide areas for staging. These 15-foot wide areas are acceptable even though the fire will be fought from any one of the four sides. There will be no more than three to five trainees on a 1-1/2-inch hose and 7 to 10 trainees on a 2-1/2-inch (63.5 mm) hose. The remainder of the class will observe the exercise. The perimeter of the fireplace shall be lined with 2-3/4-inch thick refractory and a vertical stainless steel plate in accordance with Appendix A, Figure A-9 and shall be designed for a load of 650 lb (292.5 kg) per linear foot. No coaming shall be required around the outside perimeter of the training deck; however, a safety rail shall be provided. This rail shall be constructed of 1-1/2-inch steel pipe with two horizontal rails. The horizontal rails shall line up vertically. Its purpose is to prevent personnel from falling off the training deck. The safety rail shall not have any netting or webbing. The rail shall be removable along the side of the trainer adjacent to the mockup storage pads.

a) The training deck shall consist of a 4-inch lightweight heat-resistant concrete topping on a 6 mil polyethylene bond breaker, on a concrete structural slab. The topping slab shall be designed to be sacrificial, provided in sections, and capable of thermal expansion. Expansion joint material shall consist of a ceramic fiber blanket capable of resisting temperatures of 2,000 degrees F minimum. The training deck elevation shall be 8 feet (2.44 m) above grade to allow air access to the underside of the fireplace and to allow space for the electrical, foam, and storage rooms (each with a 7 foot (2.13 m) minimum ceiling height) beneath. Where the training deck is located above the first floor rooms it shall be waterproofed. The crawl space under the training deck shall maintain 6 feet (1.83 m) of clear height. There shall be no doors leading from the ground level rooms directly into the crawl space and utility penetrations shall be sealed airtight. Stairs shall be provided at three locations to afford personnel access to the training deck. Additional ground access shall be provided at each foam training deck. The area under the foam decks and stairs shall allow free air access to the wire mesh covered openings.

MIL-HDBK-1027/1

b) The walls between the first floor rooms and the crawl space shall be airtight. Any utility penetrations shall be sealed. This precludes propane from drifting into these rooms. The crawl space shall be bounded by two walls with floor to ceiling wire mesh covered openings. The other two walls shall contain 15-foot wide air tunnels with similar wire mesh covered openings.

c) Columns used to support the perimeter of the fireplace shall be no greater than 18 feet (5.49 m) on center. These columns shall be located as indicated on the floor plan in Appendix E. Refer to paragraph 3.16.2.6 for other structural features pertaining to the fireplace opening.

3.16.2.2 Foam Deck. Eight identical foam decks shall be located around the perimeter of the training deck. The floor of the foam deck shall be constructed of steel grating and located 3-1/2 feet (1.07 m) below the training deck. The foam deck shall include the firefighting equipment found on both a Destroyer Deck (DD) and an Aircraft Carrier Deck (CV). Each deck shall be configured in accordance with Appendix E, Figure E-3. Although this combined deck is not set up to duplicate a station found on ships, appropriate gear is available for use. Included shall be a foam reel with 125 feet (38.1 m) of 1-1/2-inch hose, two faked hose racks, with 100 feet (30.48 m) of 2-1/2-inch hose each, a Stand Pipe (SP) hose station with 4-foot (1.22 m) applicator, two faked hose racks, each with 100 feet of 1-1/2-inch hose, an electrical foam pump start station, and a communications station. The communications will be provided by the device contractor. Foam shall be delivered to the deck through a 3-inch (76.2 mm) pipe with a 1-1/2-inch branch leading to the reel through a ball valve. The 3-inch pipe shall terminate in a 2-1/2-inch service valve, in accordance with NAVSHIPS Dwg. 803-1385711. Both the foam pipe and the SP hose station shall be deactivated by a valve out of sight of the trainee which can be operated by the instructors. The safety rail can be used for supports for the faked 200 feet of 1-1/2-inch hose.

a) The foam station is activated by depressing the electric foam pump start button which opens the water control valve and starts the proportioning pumps pressurizing the system with proportioned (3 percent) foam. See Figure E-6 in Appendix E. The fire can then be fought with both the 1-1/2- and 2-1/2-inch hoses. The amount of foam used for any one training exercise should be 500 gpm or two 2-1/2-inch hoses. To depressurize the system, the electric foam pump stop button must be depressed.

b) On the smaller ships the foam reel is supplied by an FS station using an FP-180 foam proportioner; however these reels are not on the flight deck. The device 19F4 is for training firefighting techniques on aircraft decks; the FP-180 training will be accomplished onboard ship.

c) Access to the foam deck shall be by inclined stairs from the training deck and a vertical ladder from the ground. It shall have a safety railing around its perimeter. Two safety chains shall be provided at the access openings for the ladder to grade and at access to training deck. The vertical

MIL-HDBK-1027/1

ladder shall only be used as an emergency exit from the foam deck.

3.16.2.3 Crash Lockers. Adjacent to the main access stairs to the training deck shall be two crash lockers with dimensions 10 by 15 feet each. These lockers shall be constructed the same as repair lockers. They will be used to store hoses, proximity suits, porta saws, jaws of life, etc. These items will be procured by the using activity through collateral equipment. Ventilation is required in the crash lockers at a rate of 6 air changes per hour.

3.16.2.4 Instructor's Station

a) A two-story high instructor's station shall be located 50 feet from a corner of the fireplace. Its siting should consider the prevailing wind. It should be upwind of the fireplace and the sun should not interfere with the view of the training deck.

b) The instructor's station and electrical room below shall be 10 by 15 feet, have 9-foot (2.74 m) high ceilings and a computer floor. A computer floor is not required for the electrical room. Access to the second floor shall be by exterior stairs. The instructor's station shall have an 8- by 2-1/2-foot high window overlooking the training deck mounted 2 feet off the computer floor.

c) The DTC is located in the electrical room.

d) The exterior wall and windows of the instructor's station facing the fireplace shall be designed to be capable of withstanding a surface temperature of 165 degrees F.

3.16.2.5 Doors. Doors associated with the 19F4 structure shall be 3 feet (0.914 m) wide hollow metal doors. This structure is not an all weather trainer. The 19F4 structure is open to the elements and has no provisions for removal of ice and snow; however, associated liquid systems shall be freeze protected.

3.16.2.6 Structural Features

a) A device contractor supplied steel framing will support the mockups and grating in the fireplace opening and at the ground storage area. The foundation for this steel framing shall be provided with the facility as follows:

(1) A reinforced concrete mat foundation shall be provided in the crawl space at the 52-foot by 36-foot fireplace opening and will support the concentrated loads from the device support columns. The concrete mat shall be pile or grade supported as required by the site soil conditions. The concrete mat shall be designed for the following column reactions and spacings:

MIL-HDBK-1027/1

<u>Location</u>	<u>Column Grid Spacing</u>	<u>Column Reaction</u>
Center 16 ft X 16 ft area	3 ft - 6 in. on center	7,500 lb
Remaining fireplace area	6 ft - 3 in. on center	10,600 lb

(2) Column bearing area will be approximately 12 inches square and will be set in a grout bed and anchored directly to the mat foundation. Minimum column distance to edge of mat shall be 2 feet. The mat shall be designed to give the device contractor the flexibility to locate columns anywhere on the mat subject to minimum column grid spacing, maximum column reactions, and minimum edge distance.

(3) Minimum mat thickness shall be 8 inches. Provide a 1/2-inch minimum expansion joint at the mat perimeter isolating the mat from the remainder of the crawl space slabs. Minimize the crack control joints in the mat foundation. Slope mat from center high point to drains. Refer to Appendix E, Figure E-7 for dimensions.

b) The training deck shall be designed as a standard training floor, 60 lb (27 kg) per square foot live load. There will be no wheeled vehicles on the deck of the 19F4 structure. Aircraft carriers use a forklift truck to aid in rescuing the pilot. The 19F4 trainer will have a 200 lb (90 kg) mannequin strapped in a seat 8 feet (2.44 m) above the deck which will be rescued using a portable ladder.

c) Some of the larger ships use a P-16, self-propelled fire truck, to fight deck fires. Because the trainer deck must be above grade due to the propane fuel, the resulting size limitations prohibit the use of the P-16. Another negative aspect of P-16 use with this structure is that it would require automotive type maintenance which is not normally associated with firefighting schools.

3.16.2.7 Miscellaneous. Various mockups will be hoisted between storage pads and the center of the fireplace by a crane. A fixed wing aircraft mockup and a helicopter mockup will be stored on the ground while ordnance mockups will be stored on the fireplace decking. Ordnance mockups will weigh approximately 100 lb (45 kg) and be positioned manually by the trainees. The mockups shall be located as shown on the floor plans of Appendix E to facilitate the crane reach.

3.16.3 Mechanical

3.16.3.1 Use Rate. The 19F4 structure (refer to Table 12) has utilities designed to support three classes of 60 trainees each week. The class will be divided into four teams of 15 trainees each with two team leaders and one center leader. Two teams at a time will fight the fires alternately at a rate of three fires per hour. The structure will be used for half a day each day of the week for two 2-day classes and one 1-day accelerated class. Each class will receive 5 hours of fire exposure time.

MIL-HDBK-1027/1

Table 12
19F4 and 19F4A Structures

CLASS SCHEDULE

	MON		TUE		WED		THU		FRI		Z
	AM	PM	AM	PM	AM	PM	AM	PM	AM	PM	
Classroom	X	X					Y	Y			Z
Structure			X	X					Y	Y	Z

Note: Classes are designated as X, Y, Z.

PROPANE USAGE

CLASS OF FIRE	NO. OF FIRES/ CLASS OF 63 MEN	FIRE TYPE	PROPANE DEMAND ft ³ /min	PROPANE USE PER FIRE 3 ft ³	TOTAL PROPANE/ CLASS
<u>First Day PM</u> B	6	Fixed Wing	5,400 ^{5/}	10,000	60,000
<u>Second Day PM</u> B B	6 <u>3</u>	Helicopter Gas Tank	5,400 ^{5/} 73	10,000 219	60,000 <u>657</u> 120,657 ft ³ / class 3,297 gal/class

- Notes:
1. Propane consumption and demand for the 1-day class are the same as those for the 2-day class.
 2. The design propane demand for the bldg. is 5,400 cfm.
 3. Propane is based on a gas pressure at the burner of 2 psi.
 4. Propane supply pressure at the trainer entry (device contractor hookup) shall be 10 psig.
 5. The average propane demand is 2,000 cfm.

MIL-HDBK-1027/1

Table 12 (Continued)
19F4 and 19F4A Structures

AGENT USAGE

<u>CLASS</u> <u>OF</u> <u>FIRE</u>	<u>NO. OF</u> <u>FIRES/</u> <u>CLASS</u>	<u>NO. OF</u> <u>HOSES</u>	<u>AFFF</u> <u>3%</u> <u>gpm</u>	<u>WATER</u> <u>TIME</u> <u>min</u>
<u>First Day PM</u>				
B	6	2-2-1/2 in.	250	5
<u>Second Day PM</u>				
B	6	2-2-1/2 in.	250	5
B	3	2-2-1/2 in.	250	3

- Notes: 1. The design water demand shall be $125 + 125 + 250 + 250 = 750$ gpm for the occasional times when 2-2-1/2-inch and 2-1-1/2-inch cooling water hoses are used together. This is the total demand for the structure. Do not add in the water for foam.
2. The maximum 3 percent foam solution demand shall be $250 + 250 = 500$ gpm.

TOTAL UTILITIES

	<u>CLASS</u>	<u>WEEKLY</u>
Propane	120,657 ft ³	361,971 ft ³
Water	36,000 gal	108,000 gal
AFFF Concentrate (100%)	1,035 gal	4,000 gal
PKP	None	

- Notes: 1. The water category includes the water portion of the AFFF (97 percent water, 3 percent AFFF for design) and the flush deck nozzle water.
2. 46 percent of the water usage for a 2-day class occurs on the first day of class. However, since the whole course is taught in one day to the accelerated students, the design daily water consumption equals the full class value.

MIL-HDBK-1027/1

3.16.3.2 Firefighting Agents

a) Flush deck nozzles are used on the flight deck of a ship as a countermeasure to prevent accumulation of contaminants during a Chemical Biological Radiation (CBR) attack and with foam to aid in fighting fires. On the 19F4 structure, the deck nozzles will be used for demonstration purposes only and shall be supplied with water only. The nozzles will be installed in the fireplace grating by the device contractor. A 6-inch (152.4 mm) water line shall terminate near the edge of and below the trainer deck with a motorized valve. The water line shall have a manual shutoff valve and a pressure regulator valve prior to the motor operated valve. The water pressure for the flush deck nozzles shall be the fire main pressure. The tie-in point for the device contractor shall be the outlet of the motorized valve.

b) The flush deck nozzles will be controlled from the instructor's station only, by activating the motorized valve. The water demand for the 19F4 structure shall not be affected by these nozzles. They will not be used simultaneously with other agents.

c) Agents used to fight aircraft deck fires will come from the foam deck. Foam will be used exclusively to fight aircraft fires. Water will be used to cool ordnance after the fire is out and used to wash contaminate off the deck.

d) No Shipboard Twin Agent Unit (SB/TAU) or twin agent reel or dual hand line (simulated from a P-16) will be associated with the 19F4 structure. Any training on this type of equipment will be provided onboard ship. PKP will not be used as a firefighting agent with this structure.

3.16.3.3 Ventilation

a) The wind generator will not be used because of crosswind problems, safety, noise and power consumption. Natural wind will be used to provide the air movement required. In an effort to retain the advantage of training with a upwind or downwind approach to the fire, the device will be configured so the fire can be attacked from any one of its four sides with equal realism. Foam decks are also located so the fire can be approached from any side.

b) The wire mesh covered openings bordering the crawl space shall be as large as the structure will allow to provide as much air under the fireplace as possible. Louvers and backdraft dampers for the 19F4 trainers are not required since neither artificial smoke nor PKP is used.

3.16.3.4 Air Conditioning. The electronic equipment in the instructor's station is expected to add 3,414.5 Btu/hr to the air conditioning load. There is no electronic equipment (device) cooling load for the electrical space below the instructor's station. This electrical space shall be cooled and heated.

MIL-HDBK-1027/1

3.16.3.5 Miscellaneous

a) Artificial smoke will be used to help trainees determine wind direction and to indicate, along with the sound of an explosion, ordnance that has heated beyond its cook-off point.

b) The courses taught on the 19F4 and 19F4A trainers require exposure to the wild hose facility. The wild hose may be taught on the ground adjacent to the 19F4 structure. Only one wild hose facility shall be required at a firefighting school.

c) The propane supply shall terminate at the side of the structure as shown in Appendix E, Figure E-1.

d) A grade mounted gantry crane shall be used to position the various aircraft mockups. The crane shall be designed in accordance with Appendix E, Figures E-4 and E-5 and shall be a double girder, double leg motorized gantry crane with an 80-foot span. The crane shall have a 3-ton capacity with top running motorized trolley hoist. The crane shall be designed for outside weather, taking into account local wind conditions. Provide electrically actuated pendant control. The crane shall meet Class III, NAVFAC P-307, Management of Weight Handling Equipment Management of Certification, requirements. Annual certification is required. During firefighting training, the crane shall be parked at the mockup end of the 19F4 trainer, maintaining a 70-foot clearance from the trainer fireplace on the deck.

Caution: The trainer shall never be operated unless the crane is in the parked position.

3.16.3.6 Foam Proportioning

a) The foam for the foam decks shall be proportioned in the foam room with a 3 percent AFFF solution being piped to each foam standpipe. Concentrate shall be pumped to the mixing tank in the foam room. An industrial type proportioner shall take 100 percent solution from the mixing tank and produce the 3 percent solution. A balanced pressure system shall be used as shown on Figure E-6 of Appendix E.

b) The High Capacity Fog Foam Generator (HCFF) or FP-1,000 are used aboard ship to proportion firefighting foam. There are aspects of this equipment which are not conducive to firefighting training. The HCFF or FP-1,000 will not be incorporated in the 19F4 or 19F4A for training purposes. This equipment type training will be accomplished aboard ship.

3.16.4 Electrical3.16.4.1 Power

MIL-HDBK-1027/1

a) The power required for the device is 85 kVA. Provide 120/208 V, three-phase service.

b) Provide eight 2-inch spare conduits from the two-story instructor's station building to the 19F4 training structure. These conduits will be used by the device contractor for both power and control. Power and control wiring shall be run in separate conduits.

3.16.4.2 Lighting. The 19F4 structure shall be lighted for nighttime operation. However, provide security lighting. The crawl space shall be fully lighted with switches by doors.

3.17 19F5 and 19F5A Structures

3.17.1 General. The 19F5 and 19F5A structures will be used for initial exposure or indoctrination firefighting training. The structure is designed to train one class of 160 students and can train five classes each week operating on a single shift. The current class size projections are:

RTC Orlando/San Diego: Average class size - 168
Max. expansion size - 200

RTC Great Lakes: Average class size - 252
Max. expansion size - 270

3.17.2 Architectural. The floor plans for the 19F5 and 19F5A structures are in Appendix F.

3.17.2.1 Layout. The 19F5 and 19F5A structures will consist of six fireplace compartments, three on either side of a large staging area. The students will line up in the staging area in front of each compartment and fight the fire through the doorway. Fireplaces will run simultaneously.

Two storage rooms will be located off of the staging area which shall provide access to the burner room. Both of the storage rooms shall be permanently heated to 50 degrees F (10 degrees C).

3.17.2.2 Ceilings. The ceilings in the fireplace compartment shall be 12 feet high. The roof over the staging area shall be high enough to provide line of sight between the second story instructor's station and the compartments. The roof over the compartments shall allow 8 feet (2.44 m) clearance for maintenance of the exhaust system and smoke generation equipment. An equipment space over the burner room may also be required. The ceiling height in the egress chamber shall be 8 feet minimum.

3.17.2.3 Doors. The doors leading to the fireplace compartments and associated with the egress chamber shall be quick-acting watertight doors. Other doors shall be hollow metal. A 6-foot wide by 7-foot high door shall be located in the staging area to accommodate large equipment on hand trucks. The

MIL-HDBK-1027/1

door shall have ramp access. No forklift trucks will be used.

3.17.2.4 Fireplaces. The exact dimensions of the burn areas are listed in the table below by fire type. Compartments are 10 by 10 feet clear in the plan.

Trash Can	6 feet by 6 feet (floor opening), located 1 foot from the back wall liner.
Bilge	10 feet by 10 feet clear (floor opening)
Electrical Panel	1 foot by 4 inches (wall mounted)

Fireplace compartments shall have refractory lined walls and ceilings. In addition, compartment walls shall have steel plate liners to protect the walls from the water hose stream and to maintain compartment temperature. The bilge fireplace compartment ceiling shall also have steel plate liner. The electrical panel and trash can fireplaces shall have grating floors. The bilge fireplace shall have a chained doorway, no floor, and a fireplace support as shown on Appendix A, Figure A-9. Required compartment dimensions shall be clear dimensions from refractory wall coating to steel plate wall liner. The fireplace compartments shall be thermally isolated from the facility structure to allow for thermal expansion.

3.17.2.5 Instructor's Station. The 19F5 and 19F5A structures shall include two 12-by 12-foot instructor's stations. One for each set of fireplace compartments. The 19F5, 19F5A structures shall be separated by an electrical room measuring 12 by 26 feet. All three rooms shall be located on the second floor along the side of the staging area and shall have a 12-inch (304.8 mm) high raised floor. Access to the instructor's stations shall be by stairway or through the electrical room. Each instructor's station shall have an 10- by 2-1/2-foot window overlooking the staging area. The lower edge of window shall be 2 feet off of the computer floor.

3.17.2.6 Egress Chamber. An emergency egress chamber shall be provided which will present the trainee with a loss of light and a high temperature, smoky environment. The trainee will enter and leave the chamber through smoke filled entryways. These entryways shall be designed to block light from entering the main chamber. Ventilation shall be such that no smoke is allowed to enter the staging area. Smoke will not be introduced in the main chamber.

a) Once inside the dark chamber, the trainee will follow a rope lanyard which will eventually lead him to the smoke filled exit. The main chamber shall be heated to 110 degrees F (43.3 degrees C) during the training scenario.

b) Provide a watertight door in the steel partition between side 1 and side 2 of the chamber and watertight openings without doors in the steel partitions making up the entryways, refer to Appendix F, Figure F-1, for details. The walls and ceiling shall be sealed with a coating chemically

MIL-HDBK-1027/1

resistant to triphenylphosphate.

3.17.2.7 Miscellaneous

a) No OBA's will be used by the trainees, therefore a fixed OBA disposal area is not required.

b) Provide a hose drying rack capable of storing twelve 50-foot lengths of hose. Once loaded, the hose drying rack shall be hoisted electrically to a mezzanine located 9 feet above the floor. The mezzanine shall be accessible from the second floor. Material for the hose drying rack should be lightweight. A heavy duty wrench-hoist system should be provided.

c) The P-250 portable, gasoline engine driven water pump will be demonstrated in front of the bleacher area. Refer to the requirements stated herein. No raised platform is required.

d) Provide bleachers for seating 250 students.

e) Provide a wild hose demonstration area. The space shall be approximately 20 by 20 by 20 feet high with an opening facing the bleachers to allow observation from the staging area. Means with unrestricted visibility shall be provided to protect the bleachers from the wild hose water spray.

3.17.3 Mechanical

3.17.3.1 Use Rate. The utilities for the 19F5 and 19F5A structures are designed to support five classes of 160 students each week. A class will be divided into two groups (A, B) of 80 men. Group A will spend the morning fighting fires in the six fireplace locations while group B watches the demonstration, i.e., wild hose, P-250 pump, portable extinguishers, etc., and goes through the emergency egress chamber. In the afternoon the two groups switch. A typical schedule will train five classes per week, 800 trainees for 52 weeks or 40,000 students per year. For class schedule and utilities requirements, see Table 13.

3.17.3.2 Firefighting Agents. Firefighting water entering the structure shall come through a motorized valve. This valve shall be controlled from the DTC and act as an emergency shutoff valve in case of an uncontrollable hose.

a) Six standpipes, two foam stations, and two foam reels shall be located in the center of the staging area. Only the reels and agents will be used for training purposes. The foam proportioning equipment which feeds the reels will be operated by the instructors. Therefore, it can be standard commercial. The design shall allow for any two reels to operate simultaneously, one for each bilge compartment.

MIL-HDBK-1027/1

Table 13
19F5 and 19F5A Structures

 CLASS SCHEDULE

A	Monday AM	240 fires
B	PM	240 fires

Note: The 2-day course includes a classroom session before the fire training.

 PROPANE USAGE

CLASS OF FIRES	NO. OF FIRES/ CLASS	FIRE TYPE	PROPANE DEMAND ft ³ min	AVERAGE FIRE DURATION min	TOTAL PROPANE USE PER FIRE ft ³	PROPANE/ CLASS FOR 1 DAY ft ³
A	160	Trash Can	10	2	20	2,400
B	160	Bilge	65	2	160	25,600
C	<u>160</u>	Electric Panel 480 fires/ class	5	2	10	<u>1,200</u> 29,200 ft ³ / class

- Notes:
1. Each fireplace will have 10 fires/hour.
 2. Maximum fires per shift is 480 fires. Classes larger than 160 students can be accommodated by reducing student fire exposure or extending the shift.
 3. Great Lakes will train additional students with the same number of fires.
 4. The propane demand is based on a gas pressure at the burner of 1 psi except for the bilge fire which is 2 psi.
 5. The design propane demand for the structure is $(10 + 65 + 5) \times 2 = 160$ CFM.

MIL-HDBK-1027/1

Table 13 (Continued)
19F5 and 19F5A Structures

AGENT USAGE

CLASS OF <u>FIRE</u>	NO. OF FIRES/ <u>CLASS</u>	NO. OF HOSES 1-1/2 in. <u>FIRE</u>	WATER gpm	AFFF 6% gpm	PKP/ FIRE lb	CO ₂ / FIRE lb	WATER TIME min
A	160	2	95				2
B	160	1	95				2
C	160	1		95	10	5	1

- Notes: 1. The design water demand is: $((95)2 + 95 + 95)2 = 760$ gpm.
 2. The portable PKP extinguishers will require 80 CO₂ charges per class.
 3. No OBA's will be used.
 4. Portable extinguishers will be used for fighting fires with PKP.

TOTAL UTILITIES

	<u>CLASS 1 DAY</u>	<u>WEEKLY</u>
Propane	29,000 ft ³	145,000 ft ³
Water	105,000 gal	525,000 gal
AFFF Concentrate (100%)	912 gal	4,560 gal
PKP	160 lb	800 lb
CO ₂	800 lb	4,000 lb

- Notes: 1. The water category includes the water portion of AFFF (94 percent water, 6 percent AFFF for design).
 2. Continuous operation can be assumed for weekly and monthly consumption.

b) Provide a 20-lb (9 kg) portable PKP extinguisher outside of each bilge compartment. Provide a 15-lb (6.75 kg) portable CO₂ extinguisher outside of each electrical panel compartment. Additional extinguishers which will be used as replacements will be purchased as collateral equipment.

MIL-HDBK-1027/1

c) The hose stations in the 19F5 structure do not require the instructor operated hose station disabling valve.

3.17.3.3 Ventilation

a) There shall be an exhaust duct leading from each fireplace compartment with a separately operated motorized floating point damper. These ducts should come together above the compartment ceiling. The design capacity of the exhaust fans for each side of the structure shall be based on the simultaneous operation of fireplaces or 18,400 cfm (520.9 m³/s) "air out." The minimum ventilation shall be 1,000 cfm (28.31 m³/s) per fireplace or 3,000 cfm (28.31 m³/s) for each side of the structure. For ventilation air per area, see Table 14.

b) Artificial smoke, butylated triphenylphosphate, will be used in fireplaces and in the emergency egress chamber.

c) Each entryway of the egress chamber shall be provided with 1,000 cfm of ventilation which will keep it under negative pressure so that the smoke will not migrate to the staging area. The exhaust grills shall be located above the entry and exit on the inside and shall draw air from the staging area through the doorway. Motorized dampers shall be provided to allow remote adjustment of the entryway ventilation rate. A second fan shall draw 1,000 cfm from each inner room of the egress chamber. The inner room fan will be used to clear stray smoke from inner rooms only after the exercise is complete. The inner room fan should not be on while trying to maintain 100 degrees F (37.7 degrees C) in the chamber. Interlock the fans to the entryway doors so they cannot run with the doors closed. The open door is the source of makeup air for the inner room exhaust fan. Heating of the egress chamber to 110 degrees F during training will be provided by the device contractor. Normal building heating shall be provided.

3.17.3.4 Air Conditioning. Electronic equipment in each instructor's station is expected to add 4,000 Btu/hr to the air load. The air conditioning to the electric room adjacent to the instructor's station has an air conditioning load of 20,000 Btu/hr due to the equipment. The normal occupancy for each of the three rooms will be two people.

3.17.4 Electrical

3.17.4.1 Power. The power for the device is 50 kVA. Provide 120/208 V, three-phase service.

3.17.4.2 Lighting. The staging area shall be lighted for training after dark. The fireplace compartments shall be lighted for maintenance from underneath the grating. No shipboard type lighting is required in the compartments of the 19F5 structure.

MIL-HDBK-1027/1

Table 14
19F5 and 19F5A Ventilation Air

PROPANE DEMAND COMPARTMENT	VENTILATION	
	AIR OUT AT <u>ft³/min</u>	<u>600 ft/min</u>
Trash Can	10	4,600
Bilge	65	11,500
Electric Panel	5	2,300

- Notes:
1. The design ventilation for each side is 18,400 cfm "air out." The minimum flushing ventilation shall be as low as the fan can turn down but never lower than 3,000 cfm "air in."
 2. Fan static pressure should be determined by bringing 60 degrees F (15.5 degrees C) air through the louvers and exhausting 600 degrees F through the exhaust system.
 3. Provide two 2,000 cfm (56.62 m³/s) fans for the egress chamber.

The egress chamber shall have interior lighting for maintenance purposes only. The light switch shall be exterior and away from the entry and exit doors.

3.18 Seawolf Structure

3.18.1 General. The Seawolf structure is a 21C12 or 21C12A trainer with a Seawolf addition and will be used to provide hands-on practical firefighting training for submarine personnel. The structure is designed to train 1 class of 20 students and can train 15 21C12 and 21C12A classes or train 10 Seawolf classes each week. Refer to Appendix G, Figures G-14 through G-17.

3.18.2 Siting. The siting requirements for the Seawolf structure are the same as for the 21C12 and 21C12A structures.

3.18.3 Architectural. The floor plans for the Seawolf structure are similar to the 21C12 and 21C12A structures except as modified by the plans given in Appendix G. The major modifications to the 21C12 and 21C12A structures for incorporating Seawolf requirements are as follows:

a) The bulk storage area was lengthened by 25 feet which provides an additional floor area of 2,000 ft² for Seawolf AFFF and water systems.

b) Three hose stations were added: two SHS4 (AFFF and/or water) and one SHS5 (water only).

MIL-HDBK-1027/1

- c) AFFF supply system with storage tanks.
- d) Water supply system with storage tank.

3.18.3.1 Layout. The seawolf structure is similar to the 21C12 and 21C12A structures except as noted herein and as shown on the Appendix G sketches.

3.18.3.2 Fireplace Compartment. Identically the same as for the 21C12 and 21C12A structures except with the addition of the SHS5 submarine hose station.

3.18.3.3 Staging Areas. The two staging areas are identical to the staging areas of the 21C12 and 21C12A structures except with the addition of one SHS4 submarine hose station for each area.

3.18.3.4 Bulk Storage. The bulk storage for the Seawolf structure is similar to the bulk storage of the 21C12 and 21C12A structures except as noted above.

3.18.3.5 Architectural Requirements. The Seawolf structure shall have the same architectural requirements as identified for the 21C12 and 21C12A structures as follows:

- CO₂ extinguisher fill station
- No repair lockers required
- Ceilings
- Doors
- Fireplaces
- Instructor's station
- AFFF fill station for extinguisher bottles
- Crawl space
- Burner room

3.18.4 Mechanical

3.18.4.1 Use Rate. The utilities for the Seawolf structure are designed to support either 10 Seawolf classes or 15 21C12 and 21C12A classes per week. Each class is 4 hours long. The 21C12 and 21C12A classes are given under the 21C12 and 21C12A criteria. The Seawolf classes consist of the following:

- a) Basic Enlisted Submarine School Students (BES) - six classes per week
- b) Submarine Officers Basic Course (SOBC) - one class per week
- c) A-495-2056 - one class per week
- d) A-495-2061 - two classes per week

For total utilities required for Seawolf structures, refer to Table 15.

MIL-HDBK-1027/1

Table 15
Total Utilities for Seawolf Structure

	<u>Daily</u>	<u>Weekly</u>	<u>Monthly</u>
Propane	21,300 cu. ft	106,000 cu. ft	355,000 cu. ft
Water	21,600 gal	72,000 gal	180,000 gal
AFFF Concentrate (100%)	152 gal	760 gal	3,294 gal
PKP	2,160 lb	10,080 lb	32,400 lb
CO ₂	1,125 lb	5,250 lb	16,875 lb

- Notes:
1. Daily rates assume three 4-hour classes in the trainer a day.
 2. Propane rates are based on the 21C12 and 21C12A course: 15 classes per week. Water rates are based on the 21C12 and 21C12A course: 15 classes per week. AFFF rates are based on the Seawolf course: 10 classes per week. Extinguisher rates (PKP and CO₂) are based on the 21C12 and 21C12A course: 15 classes per week.
 3. AFFF concentrate (100%) is 20% AFFF, 80% water.
 4. The utilities shown are based on whichever is the greater amount between the two types of courses: 21C12 and 21C12A or Seawolf.

3.18.4.2 Propane, Agent, and Extinguisher Usage Per Class. Identical to that of the 21C12 and 21C12A structures.

3.18.4.3 Firefighting Agents. The Seawolf structure shall contain seven hose stations, two stations are the combined type, three stations are the individual type, and the other two are the AFFF foam type. Each of the combined hose stations (SHS3) shall consist of the hose stations SHS1 and SHS2. The combined stations are located in the staging areas. The three individual hose stations are SHS1, SHS2, and SHS5 and are located in the fire training compartment. The SHS1 and SHS2 shall be served by one 1-1/2-inch angle globe valve.

The angle globe valve shall be perpendicular to the wall and shall be served by a piping routed in or through the wall. The SHS5 shall be served by a one-inch line with a ball valve directly connected to the fire hose reel.

The AFFF type hose stations (SHS4) are located in the staging areas. The SHS4 shall be served by one 2-inch water line and 3/4-inch AFFF line. Refer

MIL-HDBK-1027/1

to paragraph 4.9.12 and Appendix G, Figure G-15 regarding the details of the hose stations.

3.18.4.4 AFFF Hose System. The AFFF hose system for the Seawolf structure shall consist of water supply tank, foam concentrate tank, measuring and mixing tank, foam tank, and pumps for each tank. Foam concentrate will be delivered by truck in bulk and stored in a 2,000-gallon stainless steel foam concentrate tank. The foam concentrate will then be pumped into a 120-gallon measuring and mixing tank and mixed with water into the 100 percent foam solution. The foam will then be pumped into the 1000-gallon foam tank for storage and use.

For the normal operation of the AFFF hose system, the foam tank and water supply tank pumps operate simultaneously. The AFFF hose system shall be designed to allow the SHS4 hose stations to use either AFFF and water or water. Both pumps shall each have manual controls and shall each interface with the DTC. The foam pump shall supply 6 gallons per minute (gpm) of foam at 125 psig to both AFFF hose stations (SHS4). The water pump shall supply 200 gpm of water at 120 psig to both AFFF hose stations (SHS4). Refer to Appendix G, Figure G-16 for more details.

The AFFF hose stations (SHS4) consist of 50 feet of 1-1/2-inch diameter fire hose with a variable pattern nozzle and two spanner wrenches. The SHS4 hose stations shall be capable of providing either water flows or 3 percent AFFF and 97 percent water mixed flows. The AFFF hose station piping consists of 3/4-inch diameter AFFF piping and 2-inch diameter water piping. Refer to Appendix G, Figure G-16 for further details.

3.18.4.5 Mechanical and Electrical Requirements. The Seawolf structure shall have the same mechanical and electrical requirements identified for the 21C12 and 21C12A structures as follows:

- Ventilation
- Air conditioning and heating
- Cooling spray
- Breathing air
- All electrical systems including power and lighting
- Extinguisher requirements
- Propane alarm system (refer to Appendix G, Figure G-17)

MIL-HDBK-1027/1

Section 4: AGENTS AND APPARATUS

4.1 General. Substitute materials have been found to replace AFFF foam, PKP, and smoke. These substitutes were chosen to improve the trainee's environment, the treatability of the air and water effluents, and the economics of training. Equivalents other than brand names are acceptable as long as the substitute material meets the given chemical formula requirement.

Any reference to the use of the above agents in this document should be understood to mean the substitute mentioned below unless stated otherwise.

4.2 Aqueous Film-Forming Foam (AFFF)

a) AFFF is used extensively in the Navy for fighting fires aboard ship. Its main disadvantage in firefighting training is its toxicity to treatment plant bacteria and receiving stream oyster larva. The toxic characteristic did not respond to various treatment processes as measured by Methylene-Blue-Active Substance (MBAS). Therefore, the only two methods of disposal for AFFF contaminated waste water was hauling it away as a toxic waste or diluting it to under 200 ppm. The first option was prohibitively expensive and the latter alternative restricted the amount of foam to where it could only be used for demonstration purposes not for training.

b) Dilution is, however, the method of disposal of AFFF used by the fleet during the routine testing of shipboard firefighting equipment. When testing is done in harbor and coastal areas, the effluent is collected and stored until it can be transferred to shore. Once shoreside, it is metered into the municipal sewer system under permit.

4.2.1 Substitute

a) The substitute for AFFF is sodium dodecylbenzine sulfonate manufactured by Pilot Chemical Company of Avenel, New Jersey and marketed as Calsoft. It is also marketed by Whitco under the name Ultrawet K, by the Textile Chemical Company under the name Calsoft, and by the Stephan Chemical Company under the name Nacconal 35SL. It is a common industrial surfactant. Of the many types of surfactants on the market, Calsoft was chosen because it was:

- (1) Readily available in large quantities
- (2) Nonflammable
- (3) Disposable in effluent
- (4) Biodegradable
- (5) Acceptable for human health and safety

MIL-HDBK-1027/1

- (6) Adequate in foaming action
- (7) Stable at high temperature
- (8) Minimally corrosive
- (9) Cost effective for training
- (10) Compatible with the flame control logic

b) Another substitute should not be attempted without thoroughly considering each of these characteristics.

c) Calsoft can be delivered in a wide variety of forms. The solid form comes in bags and drums. The liquid form comes in cans, drums, and by tank truck in varying concentrations. The liquid form is preferred for fire training.

d) Liquid Calsoft is sold in different concentrations because the higher concentrations contain less water therefore less bulk for efficient shipping. However, 60 percent and higher concentrations of liquid Calsoft will increase handling problems for the user. In 60 percent concentrated form, the Calsoft must be heated to be transferred. If 60 percent Calsoft ever cools below 50 degrees F (10 degrees C), it must be heated and mechanically mixed before it can be used. Calsoft should be bought as a 40 percent concentrate which does not have to be kept heated except for freeze protection. The concentrate is mixed half and half with water to make a 20 percent solution of surfactant which is referred to as 100 percent AFFF in this handbook.

4.2.2 Handling System. The foam system for fire training shall consist of bulk storage for concentrate, a mixing tank for preparing 20 percent solutions, a proportioning device (see hose stations), and suitable transfer means between each. Where usage rates are practical and tank truck deliveries are available, bulk tank storage may be the most economical method. The 40 percent concentration, used for the design delivery quantity will ensure that the concentrate remains pumpable without heating under possible ambient conditions. Provide spill prevention provisions around the bulk storage area. If the bulk storage tank is underground, ensure that the pump design includes a provision for pump priming.

a) If bulk tank storage is inappropriate, provisions must be made for 450-lb (202.2 kg) bulk 55-gal (209 L) drum storage and handling.

b) A solution tank shall be provided in the utilities building for mixing the concentrate with water to make 100 percent solution (20 percent active surfactant, 80 percent inert). The tank should be sized to hold 120 percent of the maximum daily 100 percent AFFF usage. Supporting equipment shall facilitate manual batch mixing. Each day the design amount of concentrate will be pumped into the solution tank from the bulk tank or from 55-gal drums after

MIL-HDBK-1027/1

which the calculated amount of water will be added.

c) The solution tank shall have, but not be limited to, a graduated sight glass, a gage port, inlets and outlets, high level alarm, low level pump shutoff, drain, and a vent. Tank inlets shall extend to the bottom of the tank and have expansion nozzles to reduce foaming. Aspects of the design should consider the fluid's propensity to foam and the fluid's viscosity. Refer to Appendix A, Figures A-17 and A-18 for the AFFF viscosity characteristics curves.

d) Carbon steel cannot be used with the sodium dodecylbenzine sulfonate because the chemical picks up iron molecules. Tanks, pumps, piping, and appurtenances should not be carbon steel, irrespective of the solution concentration of the chemical. Copper piping or 316L stainless steel is an acceptable piping material.

e) From the solution tank the foam concentrate shall be pumped in underground pipes to the hose station day tank. The flow rate should allow the day tank(s) to be filled in approximately 15 minutes. The concentrate distribution pump should be controlled by start-stop push-button stations at each hose station. The solution tank shall include provisions for filling 5-gal cans to be used with the portable foam proportioner.

f) The device sensors can distinguish between 3 percent AFFF and pure water. However, the instructors feel that a 6 percent solution is more realistic in appearance. The proportioner is field adjustable. A 6 percent solution shall be used for design purposes unless indicated otherwise. The 19F4 trainer uses 3 percent solution.

4.2.3 Portable AFFF Fire Extinguishers. Portable AFFF fire extinguishers are only required on submarines, therefore, only used in the 21C12 and 21C12A trainers. These extinguishers are stainless steel cylinders that store 2-1/2 gal of a premixed solution of AFFF concentrate and water. The cylinders are pressurized with air to 100 psi at 70 degrees F. The AFFF is discharged from the bottom of the cylinder through the siphon tube, extinguisher valve, and discharge hose to the nozzle. The AFFF fire extinguisher weighs approximately 27 lb when fully charged and has a 55- to 65-second continuous discharge time. The AFFF solution undergoes an expansion of 6.5 to 1 when passing through the nozzle, which produces around 16 gal of expanded AFFF/water solution (foam) after discharge.

4.3 Potassium Bicarbonate. Potassium bicarbonate, PKP, is a dry chemical extinguishing agent. PKP has two main undesirable characteristics for use in fire training. It is extremely diffusive, that is it spreads in all directions like smoke and remains airborne, and it is corrosive to metal and painted surfaces.

a) Substitute. A substitute was identified as grade No. 2 sodium bicarbonate powder with an apparent density of approximately one g/cm³. Sodium bicarbonate is similar to PKP in all respects. However, no. 2 grade powder is

MIL-HDBK-1027/1

composed of large particles, i.e., 90 percent of the particles are larger than 44 microns whereas 90 percent of PKP particles are smaller than 44 microns. PKP has an apparent density of approximately 2 g/cm³. The larger particles make sodium bicarbonate less diffusive. The substitute powder is coated with silicon and therefore not soluble in water. The silicon coating will breakdown in time and then the sodium bicarbonate will dissolve in the water. Sodium bicarbonate powder's chemical composition is:

<u>COMPONENTS</u>	<u>WEIGHT/PERCENT</u>
Sodium bicarbonate, No. 2 grade	93.4
Attaclay	4.0
Mica	2.0
Silicone fluid	<u>0.6</u>
	100.0

b) Sodium bicarbonate is available in a variety of dry containers. It shall be delivered and stored in bulk quantities. Storage must be kept dry.

c) The sodium bicarbonate must then be transferred to the refill station where the proper weight is poured through a funnel into portable extinguishers and twin agent unit bottles. The same scales can be used for PKP and CO₂ refill. PKP cylinders come in 18 and 27 lb (8.1 and 13.5 kg) sizes and are provided in accordance with MIL-E-24091, Extinguisher, Fire, Portable, Potassium Bicarbonate, Dry Chemical, Cartridge-Operated Type.

4.4 Carbon Dioxide (CO₂). CO₂ will be used for fire training in the form of portable 15-lb extinguishers. The portable 15-lb extinguishers shall be in accordance with MIL-E-24269, Extinguisher, Fire, Carbon Dioxide, 15 Pound, Portable, Permanent Shutoff, Navy Shipboard Use. There are no fixed pipe CO₂ systems for training purposes. The extinguishers will be purchased as collateral equipment and stored in the repair lockers for use by the trainees. As an exception to the collateral equipment requirements, portable CO₂ extinguishers shall be provided with the training facility for the electrical room and instructor's station.

a) The 19F5, 19F5A, 21C12, and 21C12A trainers shall use a low pressure refrigerated, CO₂ bulk storage tank system. For other trainers, consideration should be given to using either a low pressure refrigerated, CO₂ bulk storage tank system or high pressure 50-lb (22.5 kg) storage cylinders for recharging the extinguishers.

b) The high pressure recharging system shall consist of 50-lb cylinders which are 51 inches (1,295.4 mm) long by 8-1/2 inches (215.9 mm) in diameter and weigh 160 lb (72 kg) when full. The cylinders contain CO₂ gas at 850 psig at 70 degrees F (21.1 degrees C). The recharging station shall consist of the following collateral equipment: tilt racks, a scale, 220 V, single-phase motor and pump, fill hose, and valves. For details, refer to Appendix A, Figure A-11. The 50-lb cylinders shall be stored in a bulk storage area located near

MIL-HDBK-1027/1

the recharging area. The bulk storage area shall be suitable for storing 1 month's supply of cylinders plus 2 weeks of empty cylinders. Sufficient access shall be provided in the bulk storage area for moving the cylinders.

c) The low pressure recharging system shall consist of a low pressure refrigerated CO₂ storage tank, fixed supply and return piping system, and a manual extinguisher fill pump capable of receiving CO₂ at 300 psig, and an oxygen monitor and alarm system.

d) The system shall be in accordance with NFPA 12, Carbon Dioxide Extinguishing Systems. The storage tank shall contain CO₂ at 0 degrees F (-17.7 degrees C) and 300 psig (1,135.5 kPa) and shall be sized to provide a minimum of 30 days of CO₂. For details, refer to Appendix I, Figures I-1 through I-7.

Caution: Extra care must be taken when recharging the extinguisher with low pressure liquid CO₂. Too much liquid CO₂ in an extinguisher will cause an explosion when the CO₂ changes state from a liquid to a gas due to expansion as the liquid heats up from 0 degrees F (-17.7 degrees C) ambient temperature.

e) CO₂ is also used in cartridges for propelling PKP from portable extinguishers. These cartridges are not refillable.

f) Due to the potential for CO₂ gas leakage, provide an oxygen (O₂) monitoring and alarm system in enclosed spaces containing the CO₂ recharging system. The O₂ monitoring and alarm system shall tie into the main propane alarm control panel so as to provide alarm and annunciation to the 24-hour duty desk, instructor's station, and to the DTC. Local alarm and flashing warning sign shall also be provided. The warning sign shall state "DANGER, CO₂ CONDITION."

g) At the closest outside entrance to the CO₂ recharging system, provide the following in weatherproof lockers with the appropriate labels:

- (1) A portable CO₂ and O₂ detection kits
- (2) An emergency air breathing "SCOTPAK."

h) Doors for the spaces containing the CO₂ recharging system shall be provided with panic hardware.

4.5 Halon. Halon is an invisible gas which is used in the Navy community. Where it is called for in the training structure it will be simulated and necessary equipment will be provided by the device contractor. No facility services are required. The Halon simulator will look like a shipboard installation but there shall be no pressurized containers inside the structure. Halon is now limited by the Navy due to possible ozone depletion.

4.6 Aqueous Potassium Carbonate (APC). APC is a type of extinguishment

MIL-HDBK-1027/1

that is used as a fixed range guard system on kitchen exhaust hoods. It will be simulated on the deep fat fryer fireplace by the use of a water spray.

4.7 Nozzles. Hose end nozzles used for firefighting training shall be provided by the user as collateral equipment. The preferred water fog nozzle is NAVSHIPS Dwg. 805-860089.

4.8 Oxygen Breathing Apparatus (OBA). OBA are used by the Navy to protect firefighters from the toxicity of the products of combustion. They contain a replaceable cartridge. Oxygen is produced by chemical reaction in the cartridge. The OBA's will be stored in the repair lockers associated with each structure. The chemicals in the spent cartridge must be completely finished producing oxygen prior to disposal. This is done by letting them set in the air a minimum of 1 hour, then recapping them and wrapping them in double poly bags. The wrapped cartridges are then stored in drums to be hauled away as hazardous waste.

4.9 Hose Stations. In the 3-inch (76.2 mm) service pipe supplying each hose station, provide a shutoff valve so the instructor can disable the station. The valve should be out of sight of the trainee where possible but in a location convenient to the instructor. The instructor's shutoff valve should be a 3-inch commercial ball valve with a locking handle.

a) Consult the using activity and when requested, provide a hose drying rack. Where the climate allows, the hose drying rack should be out in the open for maximum use of natural air movement.

b) The word "faked" in faked hose station refers to the method used to store the hose. See Appendix A, Figure A-4 for an example of a faked hose.

c) The following types of hose stations have been identified for the 19F series trainers.

4.9.1 Hose Station 1 (HS1). A 1-1/2-inch (38.1 mm) hose station, supplied with water. Refer to Appendix A, Figure A-4.

a) A 1-1/2-inch hose globe valve with one end flanged and one end threaded, NAVSHIPS Dwg. 803-1385711.

b) A 1-1/2-inch marine strainer and valve with connection coupling on one end and threaded on the other ends; provide bronze caps for the threaded ends, NAVSHIPS Dwg. 810-1385901.

c) A 50-foot (15.24 m) steel hose rack with strap, NAVSHIPS Dwg. 805-860089.

d) A 1-1/2-inch hose, 50 feet long, Fed. Spec. ZZ-H-451.

e) A 4-foot applicator.

MIL-HDBK-1027/1

f) Spanner wrench.

4.9.2 Hose Station 2 (HS2). A 2-1/2-inch (63.5 mm) hose station, supplied with water. Refer to Appendix A, Figure A-5.

a) A 2-1/2-inch hose angle valve with one end flanged and the other end threaded, NAVSHIPS Dwg. 803-1385711.

b) A 2-1/2-inch marine strainer and valve with connection coupling on one end and a threaded connection on the other ends; provide bronze end caps for the threaded ends, NAVSHIPS Dwg. 810-1385901.

c) A 2-1/2-inch by (2) 1-1/2-inch wye gate.

d) Two 100-foot (30.48 m) steel hose racks with strap, NAVSHIPS Dwg. 805-860089.

e) Four 1-1/2-inch hose, 50 feet long Fed. Spec. ZZ-H-451.

f) Two 4-foot (1.22 m) applicators.

g) Spanner wrench.

4.9.3 Foam Station (FS). Foam hose station, supplied with water. Refer to foam station diagram Appendix A, Figure A-21.

a) Single agent hose reel

b) A 1-1/2-inch hose, 125 feet long (38.1 m), MIL-H-24580

c) Foam nozzle

d) Concentrate tank

(1) 19F1A - 80 gal

(2) 19F3-B1 - 80 gal

(3) 19F3-B3, 4, and 19F5 - 100 gal

e) Electric foam proportioning pump (Blackmer pump Model BXL - 1-1/4, Manufacturer Dwg. E-4638)

f) Controls as found on damage control deck

The 100 percent AFFF concentrate line shall have a valved bypass before it enters the concentrate tank arranged so 5-gal (19 L) AFFF cans can be filled at that location.

MIL-HDBK-1027/1

4.9.4 Foam Reel (FR). Foam reel station, supplied with foam. Refer to Appendix A, Figure A-21.

- a) Single agent hose reel, Appendix A, Figure A-6.
- b) A 1-1/2-inch hose, 125 feet long, MIL-H-24580
- c) Foam nozzle
- d) Manual control valve
- e) Ball valve
- f) Controls

The foam reel is supplied with 6 percent foam from the nearest FS type hose station.

4.9.5 Stand Pipe (SP). A 2-1/2-inch stand pipe, supplied with water.

- a) A 2-1/2-inch hose angle valve with one end flanged and the other end threaded, NAVSHIPS Dwg. 803-1385711.
- b) A 2-1/2-inch marine strainer and valve with connection coupling on one end and a threaded connection on the other ends; provide bronze end caps for the threaded ends, NAVSHIPS Dwg. 810-1385901.
- c) A 2-1/2-by (2) 1-1/2-inch wye gate.

4.9.6 Submarine Hose Station 1 (SHS1). Hose station is supplied with water and is wall mounted.

- a) A 1-1/2-inch angle globe valve with one end flanged and the other end threaded, NAVSHIPS Dwg. 803-1385711. The valve shall be located 18 inches above the floor next to the hose station. The valve shall be perpendicular to the wall and shall be served by piping routed in or through the wall.
- b) A 1-1/2-inch hose, 25 feet long, MIL-H-24580.
- c) Wall mounted fire hose locker in accordance with Appendix G, Figure G-8. The hose is rolled up and stored in the locker.
- d) No strainer, wye gate, or applicator is required.

4.9.7 Submarine Hose Station 2 (SHS2). Hose station is supplied with water and is floor mounted.

- a) A 1-1/2-inch angle globe valve. Refer to SHS1 above.

MIL-HDBK-1027/1

b) A 1-1/2-inch hose, 50 feet long, MIL-H-24606, Hose Assemblies, Chlorosulfonated Polyethylene Impregnated, Double Synthetic Jacket, With Couplings, Firefighting and Other Water Service

c) Floor mounted hose cabinet in accordance with Appendix G, Figure G-9. The hose is rolled up and stored in the locker.

4.9.8 Submarine Hose Station 3 (SHS3). Hose station is supplied with water and is recessed into the wall. Hose station shall consist of the following as shown on NAVSEA Dwg. 608-4674414: (SHS3 is part of the combined submarine hose station.)

- a) A 1-1/2-inch hose, 50 feet long, MIL-H-24606
- b) Fire hose rack per NAVSEA Dwg. 608-4674414
- c) One applicator per BUSHIPS Dwg. 810-1385834
- d) Two spanner wrenches per NAVSHIPS Dwg. 810-4444647

The spanner wrenches and applicator shall be clamped in the recessed area of the station. The clamps shall be per NAVSEA Dwg. 608-4674414. SHS3 shall be recessed into a space of the wall with dimensions of 4 feet 2 inches height from the floor to top of the opening by 30 inches wide by 8 inches deep.

4.9.9 Combined Submarine Hose Station (CSHS). Hose station is supplied with water and consists of SHS3 recessed into the wall with SHS1 on a metal plate mounted to cover SHS3. The metal plate shall be removable and shall be provided over SHS3 to hide SHS3. The plate shall be designed to be removed by one or two men. Clips or other methods of attachment shall be provided for attaching the plate over SHS3. SHS1 shall be permanently attached to the metal plate. A 1-1/2-inch (38.1 mm) angle globe valve normally furnished with SHS1 shall be provided next to the combined hose station.

4.9.10 PKP Fire Extinguisher (PFE). A 27-lb portable PFE shall be provided with single AFFF foam reels, as shown on the appendixes floor plans, and shall be in accordance with MIL-E-24091.

4.9.11 Twin Agent Reels (TAR). The TAR and system have been replaced by a single AFFF FR and a 27-lb portable PFE which will provide a similar function to the TAR system.

4.9.12 Submarine Hose Station 4 (SHS4). Hose station is supplied with either water or 3 percent AFFF and 97 percent water mixtures. AFFF delivered to the hose station, prior to mixture with water, is 100 percent AFFF concentrate (20 percent AFFF, 80 percent water). The hose station shall be wall mounted at floor level in accordance with Appendix G, Figure G-15. The hose station shall consist of the following military and proprietary equipment:

MIL-HDBK-1027/1

- a) One 3/4-inch constant flow valve, Griswald control valve, Model 8738F-A
- b) Fire hose rack per NAVSEA Dwg. 804-860089
- c) One 1-1/2-inch hose, 50 feet long, MIL-H-24606.
- d) Adjustable pattern fire hose nozzle, Model N-244, MIL-N-24408, Nozzle Fire Hose, Combination Aqueous Film Forming Foam, Water Spray, Adjustable Pattern (Shipboard Use)
- e) Two spanner wrenches in accordance with NAVSHIPS Dwg. 810-4444647 and mounted on wall next to the SHS4 using clips
- f) A 1-1/2-inch pipe hose connection, MIL-C-24679

4.9.13 Submarine Hose Station 5 (SHS5). Hose station is supplied with water only and is floor mounted. Hose station consists of the following:

- a) Ball valves
- b) One 1-1/2-inch hose, 25 feet long, MIL-H-24606
- c) Adjustable pattern fire hose nozzle, Model N-244, MIL-N-24408
- d) Two spanner wrenches in accordance with NAVSHIPS Dwg. 810-4444647
- e) Fire hose reel station, MIL-R-24414, Reels and Guides, Hose, Firefighting Manually Operated, Type III, with hose guides

MIL-HDBK-1027/1

Section 5: PROTECTION OF THE ENVIRONMENT

5.1 Permits

a) OPNAVINST 5090.1, Environmental and Natural Resources Protection Manual, Chapter 6, Air Pollution Abatement states the firefighting schools shall comply with state open burning regulations or have prior Chief of Naval Operations (CNO) approval for a delayed compliance request.

b) Discharge permits for air and water must be negotiated with the state for each site. This must be done early in the project so the scope of monitoring and treatment can be determined. It is important to have discharge information adequately prepared and use a positive approach. Water usage permits may also be required depending on locality and municipal and state regulations. For typical air emissions requirements, see Table 16; for wastewater characteristics, see Table 17.

5.2 Air

5.2.1 PKP. The 19F series trainers use clean burning propane for fuel, therefore, the only sources of air pollution are the PKP used as a firefighting agent and the particulates in the artificial smoke. One of the parameters used to choose a substitute for PKP was particle size. Grade No. 2 sodium bicarbonate was chosen. Ninety percent of its particles are larger than 44 microns with an average particle size of 100 microns. Ninety percent of PKP particles are smaller than 44 microns with an average particle size of 20 microns. For comparison, a human hair is approximately 100 microns in diameter. The large particle PKP substitute is less diffusive than PKP with most particulate falling out before the effluent leaves the training compartment. For particulate compliance see Appendix A, Figure A-10.

5.2.2 Artificial Smoke

a) The artificial smoke is butylated triphenylphosphate (TAP). TAP smoke is a hot air or aerosol mixture which produces a negligible residue. The smoke particle size can be adjusted from 0.5 to 2 microns. Liquid consumption is about one L/min and an exercise may use smoke for 20 seconds which equals 11 exercises per gallon.

b) The particulates listed occur only during fires where PKP is used as an extinguishing agent. The discharge amounts to 0.02 lb (0.009 kg) for each training exercise which uses a portable extinguisher. There is a maximum of three of each type of fire per hour in the 19F1A which yields a discharge rate of 0.08 lb (0.036 kg) per hour.

MIL-HDBK-1027/1

Table 16
Typical Air Emissions Requirements

TYPICAL AIR EMISSION CONCERNS	TYPICAL LIMITS (VIRGINIA)	TYPICAL EFFLUENT PPM/RUN
CO	---	negligible
HC	---	negligible
NO _x	---	negligible
XO _x	2,000 ppm	none
Particulates	0.75 lb/hr	0.08 lb/hr
Tear Gas	(exempted for training purposes)	19.5 grams

c) Visible emission from a training structure will be comprised of artificial smoke, a white colored hot air or aerosol mixture, and water vapor both of which will evaporate to a colorless gas with no particulates. Where visible emission is not permissible, treatment should consist of allowing the effluent to evaporate prior to discharge.

d) Continuous monitoring of the air effluent will probably not be required to determine code compliance, however, this must be negotiated with the local authorities.

5.3 Wastewater

5.3.1 General. The water effluent from the training structures contains two major contaminants in varying degrees depending on the training being given. Sodium bicarbonate and excessive concentrations of biodegradable surfactant are the contaminants. Wastewater is channeled to a collection tank for pretreatment. The surface runoff from fire training facility pavement can go directly to the storm drain since firefighting agents used outside a structure are also collected and sent to pretreatment.

a) Wastewater effluent characteristics are as noted below in Table 17. These wastewater characteristics are based on actual bench tests performed by LANTNAVFACENGCOCOM. Limitations for each of these characteristics may vary on a local or state level. Typical wastewater surcharge limits are provided below in Table 18. It shall be the responsibility of the EFD's to:

- (1) Determine the required level of wastewater treatment.
- (2) Determine applicable regulations necessary to obtain the wastewater permit.
- (3) Determine the necessity of additional (if required) environmental studies of the projected wastewater to identify:

MIL-HDBK-1027/1

Table 17
Wastewater Characteristics

Trainer Structure	19F1A/ 19F1B	19F4/ 19F4A	19F5/ 19F5A	19F3A/ 19F3C	21C12/ 21C12A	19F3/ 19F3B	Composite
Date of Test	11/14/89	11/14/89	11/14/89	11/14/89	11/14/89	11/14/89	7/19/89
Test No.	B8917164	B8917162	B8917163	B8917167	B8917165	B8917166	B8908356
BOD, mg/l	23	10	219	62	44	<127	104
COD, mg/l	120000	33000	3900	780	290	8300	4800
TSS, mg/l	77	5	700	250	5146	58	57
TDS, mg/l	69088	15810	9508	2625	132461	4003	2330
MBAS, mg/l	3000	6000	400	100	100	N/A	300
Oil & Grease, mg/l	24	30	19	15	6	N/A	14
PH	not tested	not tested	not tested	not tested	not tested	not tested	not tested

PRIORITY POLLUTANTS (TEST RESULTS)

VOLATILES, ug/l

Acrolein	not tested	not tested	not tested	not tested	not tested	not tested	not tested
Acrylonitrile	not tested	not tested	not tested	not tested	not tested	not tested	not tested
Benzene	<0.10	<1	<0.10	<0.10	<0.10	<10	<0.10
Bis (chloromethyl) ether	not tested	not tested	not tested	not tested	not tested	not tested	not tested
Bromoform	<0.10	<1	<0.10	<0.10	<0.10	<0.10	<0.10
(Tribromomethane)							
Carbon tetrachloride	<0.10	<1	<0.10	<0.10	<0.10	<0.10	<0.10
Chlorobenzene	<0.10	<1	<0.10	<0.10	<0.10	<0.10	<0.10
Chlorodibromomethane (Dibromochloromethane)	<0.10	<1	<0.10	<0.10	<0.10	<0.10	<0.10
Chloroethane	<0.10	<1	<0.10	<0.10	<0.10	<0.10	<0.10
2-Chloroethylvinyl ether	<0.10	<1	<0.10	<0.10	<0.10	<0.10	<0.10

MIL-HDBK-1027/1

Table 17 (Continued)
Wastewater Characteristics

Trainer Structure	19F1A/ 19F1B	19F4/ 19F4A	19F5/ 19F5A	19F3A/ 19F3C	21G12/ 21G12A	19F3/ 19F3B	Composite
Date of Test	11/14/89	11/14/89	11/14/89	11/14/89	11/14/89	11/14/89	7/19/89
Test No.	B8917164	B8917162	B8917163	B8917167	B8917165	B8917166	B8908356
Chloroform (Trichloromethane)	<0.10	<1	<0.10	<0.10	<0.10	<0.10	<0.10
Dichlorobromomethane (Bromodichloromethane)	<0.10	<1	<0.10	<0.10	<0.10	<0.10	<0.10
Dichlorodifluoro- methane (Fluorocarbon-12)	not tested	not tested	not tested	not tested	not tested	not tested	not tested
(Difluorodichloromethane)	not tested	not tested	not tested	not tested	not tested	not tested	not tested
1,1-Dichloroethane	<0.10	<1	<0.10	<0.10	<0.10	<0.10	<0.10
1,2-Dichloroethane	<0.10	<1	<0.10	<0.10	<0.10	<0.10	<0.10
1,1-Dichloroethylene	<0.10	<1	<0.10	<0.10	<0.10	<0.10	<0.10
(1,1-Dichloroethene)	<0.10	<1	<0.10	<0.10	<0.10	<0.10	<0.10
1,2-Dichloropropane	<0.10	<1	<0.10	<0.10	<0.10	<0.10	<0.10
1,3-Dichloropropylene (cis-1,3- dichloropropene)	<0.10	<1	<0.10	<0.10	<0.10	<0.10	<0.10
(trans-1,3- dichloropropene)	<1	<0.10	<0.10	<0.10	<0.10	<0.10	<0.10
Ethylbenzene	<0.10	<1	<0.10	<0.10	<0.10	<0.10	<0.10
Methyl bromide (Bromomethane)	<0.10	<1	<0.10	<0.10	<0.10	<0.10	<0.10
Methyl chloride (Chloromethane)	<0.10	<1	<0.10	<0.10	<0.10	<0.10	<0.10
Methylene chloride	<0.10	<1	<0.10	<0.10	<0.10	<0.10	<0.10
Milligrams per liter							
Micrograms per liter							
(Dichloromethane)		<1					
1,1,2,2- Tetrachloroethane	<0.10	<1	<0.10	<0.10	<0.10	<0.10	<0.10
Tetrachloroethylene (Tetrachloroethene)	<0.10	<1	<0.10	<0.10	<0.10	<0.10	<0.10

MIL-HDBK-1027/1

Table 17 (Continued)
Wastewater Characteristics

Trainer Structure	19F1A/ 19F1B	19F4/ 19F4A	19F5/ 19F5A	19F3A/ 19F3C	21C12/ 21C12A	19F3/ 19F3B	Composite
Date of Test	11/14/89	11/14/89	11/14/89	11/14/89	11/14/89	11/14/89	7/19/89
Test No.	B8917164	B8917162	B8917163	B8917167	B8917165	B8917166	B8908356
Toluene	<0.10	<1	<0.10	<0.10	<0.10	<0.10	<0.10
1,2 trans-dichloro-ethylene	<0.10	<1	<0.10	<0.10	<0.10	<0.10	<0.10
(trans 1,2- dichloroethene)							
1,1,1-Trichloroethane	<0.10	<1	<0.10	<0.10	<0.10	<0.10	<0.10
1,1,2-Trichloroethane	<0.10	<1	<0.10	<0.10	<0.10	<0.10	<0.10
Trichloroethylene	<0.10	<1	<0.10	<0.10	<0.10	<0.10	<0.10
Trichlorofluoromethane	<0.10	<1	<0.10	<0.10	<0.10	<0.10	<0.10
Vinyl chloride (Chloroethylene)	<0.10	<1	<0.10	<0.10	<0.10	<0.10	<0.10
Xylenes	not tested	not tested	not tested	not tested	not tested	not tested	not tested
ACIDS, ug/l							
2-Chlorophenol	*	<1	<1	<1	<1	<1	<10
2,4-Dichlorophenol	*	<1	<1	<1	<1	<1	<10
2,4-Dimethylphenol	*	<1	<1	<1	<1	<1	<10
4,6-Dinitro-o-cresol (4,6-Dinitro-othro-cresol)	*	<2	<2	<2	<2	<2	<10
(4,6-Dinitro-2-methylphenol)							
2,4-Dinitrophenol	*	<4	<4	<4	<4	<4	<10
2-Nitrophenol	*	<2	<2	<2	<2	<2	<10
4-Nitrophenol	*	<2	<2	<2	<2	<2	<10
P-chloro-m-cresol (Para-chloro-meta-cresol)	*	<1	<1	<1	<1	<1	<10
(4-chloro-3-methylphenol)							
Pentachlorophenol	*	<2	<2	<2	<2	<2	<10

MIL-HDBK-1027/1

Table 17 (Continued)
Wastewater Characteristics

Trainer Structure	19F1A/ 19F1B	19F4/ 19F4A	19F5/ 19F5A	19F3A/ 19F3C	21C12/ 21C12A	19F3/ 19F3B	Composite
Date of Test	11/14/89	11/14/89	11/14/89	11/14/89	11/14/89	11/14/89	7/19/89
Test No.	B8917164	B8917162	B8917163	B8917167	B8917165	B8917166	B8908356
Phenol	*	<1	<1	<1	<1	<1	<10
2,4,6-Trichlorophenol	*	<2	<2	<2	<2	<2	<10
BASE/NEUTRALS, ug/l							
Acenaphthene	*	<1	<1	<1	<1	<1	<10
Acenaphthylene	*	<1	<1	<1	<1	<1	<10
Anthracene	*	<1	<1	<1	<1	<1	<10
Benzidine	*	<10	<10	<10	<10	<10	<50
Benzo(a)anthracene	*	<1	<1	<1	<1	<1	<10
(1,2-benzanthracene)							
Benzo(a)pyrene	*	<1	<1	<1	<1	<1	<10
(3,4-benzopyrene)							
3,4-Benzofluoranthene	*	<1	<1	<1	<1	<1	<10
(Benzo-(B) fluoranthene)							
Benzo(ghi)perylene	*	<1	<1	<1	<1	<1	<10
Benzo(k)fluoranthene							
(11,12-Benzofluoranthene)							
Bis (2-chloroethoxy)	*	<1	<1	<1	<1	<1	<10
methane							
Bis (2-chloroethyl) ether	*	<1	<1	<1	<1	<1	<10
(Dichloroethyl ether)							
Bis (2-chloroisopropyl ether	*	<1	<1	<1	<1	<1	<10
Bis (2-ethylhexyl) phthalate	*	<1	<1	<1	<1	<1	21
4-Bromophenyl phenyl ether	*	<1	<1	<1	<1	<1	<10
Butylbenzyl phthalate	*	<1	<1	<2	<1	<1	<10
2-chloronaphthalene	*	not tested	not tested	not tested	not tested	not tested	<10
4-chlorophenyl phenyl ether	*	<1	<1	<1	<1	<1	<10
Chrysene	*	<1	<1	<1	<1	<1	<10
Dibenzo (a,h) anthracene	*	<1	<1	<1	<1	<1	<10

MIL-HDBK-1027/1

Table 17 (Continued)
Wastewater Characteristics

Trainer Structure	19F1A/ 19F1B	19F4/ 19F4A	19F5/ 19F5A	19F3A/ 19F3C	21C12/ 21C12A	19F3/ 19F3B	Composite
Date of Test	11/14/89	11/14/89	11/14/89	11/14/89	11/14/89	11/14/89	7/19/89
Test No.	B8917164	B8917162	B8917163	B8917167	B8917165	B8917166	B8908356
(1,2,5,6-dibenzanthracene)							
1,2-Dichlorobenzene	<0.10	<1	<0.10	<0.10	<0.10	<0.10	<10
1,3-Dichlorobenzene	<0.10	<1	<0.10	<0.10	<0.10	<0.10	<10
1,4-Dichlorobenzene	<0.10	<1	<0.10	<0.10	<0.10	<0.10	<10
3,3-Dichlorobenzidine	*	<2	<1	<1	<2	<2	<20
Diethyl phthalate	*	<1	<1	<1	<1	<1	<10
Dimethyl phthalate	*	<1	<1	<1	<1	<1	<10
Di-n-butyl phthalate	*	<1	<1	<1	<1	<1	<10
2,4-Dinitrotoluene	*	<1	<1	<1	<1	<1	<10
2,6-Dinitrotoluene	*	<1	<1	<1	<1	<1	<10
Di-n-octyl phthalate	*	<1	<1	<1	<1	<1	<10
1,2-Diphenylhydrazine	*	not tested	not tested	not tested	not tested	not tested	not tested
Fluoranthene	*	<1	<1	<1	<1	<1	<10
Fluorene	*	<1	<1	<1	<1	<1	<10
Hexachlorobenzene	*	<1	<1	<1	<1	<1	<10
Hexachlorobutadiene	*	<1	<1	<1	<1	<1	<10
Hexachlorocyclopentadiene	*	<1	<1	<1	<1	<1	<10
Hexachloroethane	*	<1	<1	<1	<1	<1	<10
Indeno (1,2,3-cd) pyrene	*	<1	<1	<1	<1	<1	<10
Isophrone	*	<1	<1	<1	<1	<1	<10
Napthalane	*	<1	<1	<1	<1	<1	<10
Nitrobenzene	*	<1	<1	<1	<1	<1	<10
N-nitrosodimethylamine	*	<1	<1	<1	<1	<1	<10
(Dimethyl nitrosamine)							
N-nitroso-di-n-propylamine	*	<1	<1	<1	<1	<1	<10
N-nitrosodiphenylamine	*	<1	<1	<1	<1	<1	<10

MIL-HDBK-1027/1

Table 17 (Continued)
Wastewater Characteristics

Trainer Structure	19F1A/ 19F1B	19F4/ 19F4A	19F5/ 19F5A	19F3A/ 19F3C	21C12/ 21C12A	19F3/ 19F3B	Composite
Date of Test	11/14/89	11/14/89	11/14/89	11/14/89	11/14/89	11/14/89	7/19/89
Test No.	B8917164	B8917162	B8917163	B8917167	B8917165	B8917166	B8908356
Phenanthrene	*	<1	<1	<1	<1	<1	<10
Pyrene	*	<1	<1	<1	<1	<1	<10
1,2,4-Trichlorobenzene	*	<1	<1	<1	<1	<1	<10
<u>PESTICIDES, ug/l</u>							
Aldrin	*	not tested	<0.2	<0.1	0.07	<0.01	<0.03
Alpha-BHC	*	not tested	0.09	0.04	0.04	0.07	<0.03
Beta-BHC	*	not tested	<1	<0.50	<0.10	<0.10	0.86
Gamma-BHC	*	not tested	0.15	0.06	0.06	0.08	not tested
(Lindane)							
Delta-BHC	*	not tested	<0.3	<0.7	0.07	0.15	0.04
Chlordane	*	not tested	<5	<2.5	<2.5	<2.5	not tested
4,4'DDT	*	not tested	<1	<0.50	<0.50	<0.5	not tested
4,4'DDE	*	not tested	<0.3	<0.15	<0.15	0.15	not tested
4,4'DDD	*	not tested	<0.6	<0.30	<0.30	<3	not tested
Dieldrin	*	not tested	<0.2	<0.10	<0.10	<0.10	not tested
a-endosulfan	*	not tested	<0.3	<0.15	<0.15	<0.15	not tested
b-endosulfan	*	not tested	<0.4	<0.12	<0.20	<0.20	not tested
Endosulfan sulfate	*	not tested	<0.8	<0.40	<0.40	<0.40	<0.11
Endrin	*	not tested	<0.8	<0.40	<0.40	<0.40	<0.11
Endrin aldehyde	*	not tested	<0.6	<0.13	<0.30	<0.30	<0.08
Heptachlor	*	not tested	<0.2	<0.10	<0.10	<0.16	<0.03
Heptachlor epoxide	*	not tested	<0.2	0.08	<0.10	<0.10	<0.03
PCB-1242							
(AROCLOL 1242)	*	not tested	<25	<12.5	<12.5	<12.5	<3.5
PCB-1254							
(AROCLOL 1254)	*	not tested	<25	<12.5	<12.5	<12.5	<3.5
PCB-1221							
(AROCLOL 1221)	*	not tested	<50	<25	<25	<25	<3.5

MIL-HDBK-1027/1

Table 17 (Continued)
Wastewater Characteristics

Trainer Structure	19F1A/ 19F1B	19F4/ 19F4A	19F5/ 19F5A	19F3A/ 19F3C	21C12/ 21C12A	19F3/ 19F3B	Composite
Date of Test	11/14/89	11/14/89	11/14/89	11/14/89	11/14/89	11/14/89	7/19/89
Test No.	B8917164	B8917162	B8917163	B8917167	B8917165	B8917166	B8908356
PCB-1232							
(AROCOLOR 1232)	*	not tested	<50	<25	<25	<25	<3.5
PCB-1248							
(AROCOLOR 1248)	*	not tested	<25	<12.5	<12.5	<12.5	not tested
PCB-1260							
(AROCOLOR 1260)	*	not tested	<10	<5	<5	<5	<1.4
PCB-1016	*	not tested		not tested	not tested	not tested	<3.5
Toxaphene	*	not tested	<20	<10	<10	<10	not tested
<u>METALS, mg/l</u>							
all reported as total metals)							
Antimony (Sb)	<0.1	not tested	not tested	<0.1	<0.1	<0.1	<0.2
Arsenic (As)	0.01	not tested	not tested	0.003	0.018	0.002	0.001
Beryllium (Be)	<0.003	not tested	not tested	<0.003	<0.003	<0.003	<0.005
Cadmium (Cd)	<0.003	not tested	not tested	<0.003	0.004	<0.003	<0.0002
Chromium (Cr)	0.17	not tested	not tested	<0.003	0.1	<0.03	<0.05
Copper (Cu)	0.09	not tested	not tested	0.06	0.15	0.05	0.01
Lead (Pb)	<0.03	not tested	not tested	<0.03	<0.03	<0.03	<0.001
Mercury (Hg)	<0.002	not tested	not tested	<0.002	<0.002	<0.002	<0.002
Nickel (Ni)	<0.02	not tested	not tested	<0.02	0.05	<0.02	<0.04
Selenium (Se)	<0.02	not tested	not tested	0.004	0.002	<0.002	<0.002
Silver (Ag)	<0.01	not tested	not tested	0.02	<0.01	<0.01	<0.01
Thallium (Tl)	not tested	not tested	not tested	not tested	not tested	not tested	<0.1
Zinc (Zn)	0.09	not tested	not tested	0.07	0.21	0.07	0.06

MIL-HDBK-1027/1

Table 18
Wastewater Surcharge Limits

		TYPICAL LIMITS (maximum)	(Based on domestic sewage)
BOD	- Biological Oxygen Demand	230 ppm*	
COD	- Chemical Oxygen Demand	550 - 700 ppm*	
pH	- measure of acidity or alkalinity of a solution	6.5 - 8.5*	
Oil and Grease	100 ppm		
TSS	- Total Suspended Solids (consists mostly of siliconized sodium bicarbonate particles)	250 ppm*	
MBAS	- measure of surfactant quantity	200 ppm	

*Note: These are typical surcharge limits, not compliance limits.

MIL-HDBK-1027/1

- (a) BOD - Biological Oxygen Demand
- (b) COD - Chemical Oxygen Demand
- (c) pH
- (d) TSS - Total Suspended Solids
- (e) TDS - Total Dissolved Solids
- (f) Priority Pollutant Scans
- (g) EPA Priority Pollutant Scans

b) The effluent is not toxic as the high COD could imply and is completely biodegradable when combined with acclimated bacteria. Surfactant quantities in excess of 200 ppm will require the addition of an anti-foaming agent to suppress foaming. A typical anti-foaming agent is Betz No. 300 defoamer.

c) Firefighting trainer wastewater will always require secondary treatment before being discharged to the environment because of high BOD and COD.

d) Provisions for onsite biological treatment must be provided where the receiving stream does not include secondary treatment. At those sites where Navy owned secondary treatment will be required, the design should consider the effect of precipitate on the treatment process. High surfactant effluent generates a precipitate so it may be desirable to reduce the precipitate in the biological section by flocculating and sedimentation prior to treatment.

5.3.2 Separation Chamber. The large particle siliconized sodium bicarbonate is partially soluble in water; however, its density is so close to that of water it will stay in suspension with the slightest agitation. Grit and sludge from other sources will accumulate in the tanks associated with the wastewater stream and a method for its removal shall be included in the tank design. Training wastewater from the fire training structure shall be piped to a separation chamber to remove the propane. For details refer to paragraph 3.2.9 and Appendix A, Figure A-16.

5.3.3 Pretreatment. Fire training wastewater shall be collected in an equalization tank sized to hold 125 percent of the largest one day's effluent. This will allow the various firefighting agent concentrations to mix and dilute each other. It will also allow a homogeneous batch of waste water to be monitored and then discharged to the sanitary sewer system at a controlled rate. There shall be two equal size equalization tanks so that one can be discharging while the second is receiving. During maintenance periods the active tank can discharge at night. Provide a separate containment for each of the three

MIL-HDBK-1027/1

chemicals used for the pretreatment. The containment basin shall be designed to keep chemicals from mixing and to control chemicals in the event of spillage. A drain shall not be provided. The containment shall be designed to hold 125 percent of the amount of chemical drum storage intended for the area. Provide local exhaust in the chemical containment area. The exhaust system shall manually operate from the local area.

a) Piping and valves associated with the equalization tanks shall be designed for flexibility of use. The tanks should overflow to each other. Each tank shall have provisions for mechanical agitation and sludge removal. The agitation should be a high volume low head pumped recirculation system with a 90-degree elbow and length of pipe at the discharge so the operator can manually adjust between submerged or open discharge. The open discharge would afford some aeration. Sludge handling provisions may consist of a sump or trough to which the grit can be hosed for removal by shovel and bucket. The sump should have a drain piped directly to the exterior of the tank for future addition of a pumped system if it becomes practical. Provide permanent personnel access to the bottom of the tanks and a standpipe, SP, so the tanks can be hosed down with a 1-1/2-inch fire hose.

b) Consideration should be given to the option of using a covered reservoir. The trade-offs are the cost of disposing of collected precipitation and freeze protection.

c) A chemical addition system shall be provided for the addition of acid, caustic, and defoaming agent. These three chemicals shall be separately pumped at an adjustable rate to either equalization tank. The injection rate shall be determined manually. Prior to discharging the wastewater to a secondary treatment plant, the operator will determine the pH of the effluent and make adjustments as necessary. Automatic pH adjustment with manual override can also be used.

d) When the pH is adjusted, the wastewater is ready for discharge. If monitoring is required by local authorities, it should be done at this time. A daily log of sampling data and chemical additions should be maintained by the user. Discharge to the sewer system shall be controllable and verifiable because the rate will be used for billing purposes. The preferred system is dual sump pumps designed to evacuate the tank in 8 to 10 hours.

e) The municipal treatment plant will periodically want a chemical analysis of the effluent being discharged to it. The reporting period may be short at first but then lengthened as confidence in the pretreatment process is gained. A sampling will best be done by a contract laboratory since its purpose is to determine permit compliance and its final frequency will not justify funding "in-house" capability. An automatic sample taking machine shall be provided at fire training sites to facilitate the sample taking process. The controls for sump and recirculation pumps shall include level controls, lead-log capability, alarm conditions for high-high and pump failure. Alarm conditions shall be sent to the central annunciator panel in the utility building and to

MIL-HDBK-1027/1

the 24-hour duty desk.

f) The inlet to the discharge and recirculation pumps shall be provided with readily cleanable strainer to catch leaves and frogs, etc., which have been a problem in the past.

g) Pumps which take suction from the equalization tank shall be protected by a low level shutoff switch.

5.3.4 Recovery. Wastewater recovery will sometimes cost more than purchasing and disposing of potable water. In some instances, however, water use may be restricted and the more expensive route will be necessary. Recycled water must not cause a health hazard and must be compatible with the device sensors. To avoid a health hazard, the organic materials added during firefighting must be removed and the water must then be made clear since the device sensors use opacity to differentiate between foam and water. A carbon absorption procedure would be required to remove the organic material followed by a reverse osmosis system to remove the remaining dissolved solids and clear up the water. Since there are chemical compounds which are not removed by the above processes, the addition of new water and blow down would still be required. If recycling water is a serious consideration, more study will be required to derive an acceptable system.

a) Wastewater associated with firefighting structures have low suspended solids, high Dissolved Solids (DS), high BOD, high COD, high pH, and high Total Toxic Organics (TTO) levels. Recycling will arithmetically escalate the untreated portions of the wastewater (DS, BOD, COD, pH, and TTO), after each training scenario, to such high levels that the device sensors and training personnel's health could be effected. Also, high levels of TDS, BOD, COD, pH, and TTS may prevent direct discharge into a sanitary sewer. The recycling system must consider each of the portions. The device sensor water requirements are given in the chart below.

pH Range	7.5 (max) - 6.5 (max)
Particle Size	40 microns (max)
Color	None
Refoaming	Must not foam when sprayed
Safety	Not harmful to personnel

b) Recycling of water does not effect the storage requirement for potable water. The EFD environmental quality division must determine the required wastewater treatment, applicable regulations necessary to obtain the wastewater permit, and the necessity of required environmental studies of the projected wastewater to identify: BOD, COD, pH, TSS, TDS, priority pollutant scans, Environmental Protection Agency (EPA) priority pollutant scans as required; water reclaim.

MIL-HDBK-1027/1

THIS PAGE WAS INTENTIONALLY LEFT BLANK

MIL-HDBK-1027/1

APPENDIX A
GENERAL

19F1A, 19F3, 19F3A, 19F1B, 19F3B, and 19F3C Bilge Fireplace Structure	A-1A
19F5, 19F5A Bilge Fireplace	A-1B
19F1A, 19F1B, 19F3, 19F3A, 19F3C Oil Spray/Bilge Fireplace	A-1C
Typical Deep Fat Fryer Fireplace	A-2
Typical Mattress/Locker Fireplace	A-3
Hose Station Detail HS1 - 1-1/2"	A-4
HS2 - 2-1/2-" Hose Station Detail	A-5
FR - AFFF Hose Reel Detail	A-6
Quick Acting Watertight Door	A-7
Ellison Type Door	A-8
Fireplace Support	A-9A-B
Particulate Compliance	A-10
Recharging Tilt Rack and Fill Equipment	A-11
Watertight Hatch for Emergency Escape Trunk	A-12
Wild Hose Demonstration Facility	A-13A
Wild Hose Post Detail	A-13B
Two Position Control Interface	A-14
Portable Pump P-250 Demonstration Facility	A-15
Separation Chamber, 21C12 & 19F Series Devices	A-16
Calsoft L-40 Viscosity Characteristic Curve	A-17
Calsoft L-40/Water Viscosity Characteristic Curve	A-18
Floating Point Control Interface	A-19
Exhaust Fan/Crawl Space Power Controls & Interlocks	A-20A-D
AFFF Station	A-21A-J
Luminaire, Types 1 & 2	A-22

NOTES:

FIREPLACE DIMENSIONS SHOWN ARE INSIDE
FIREPLACE DIMENSIONS

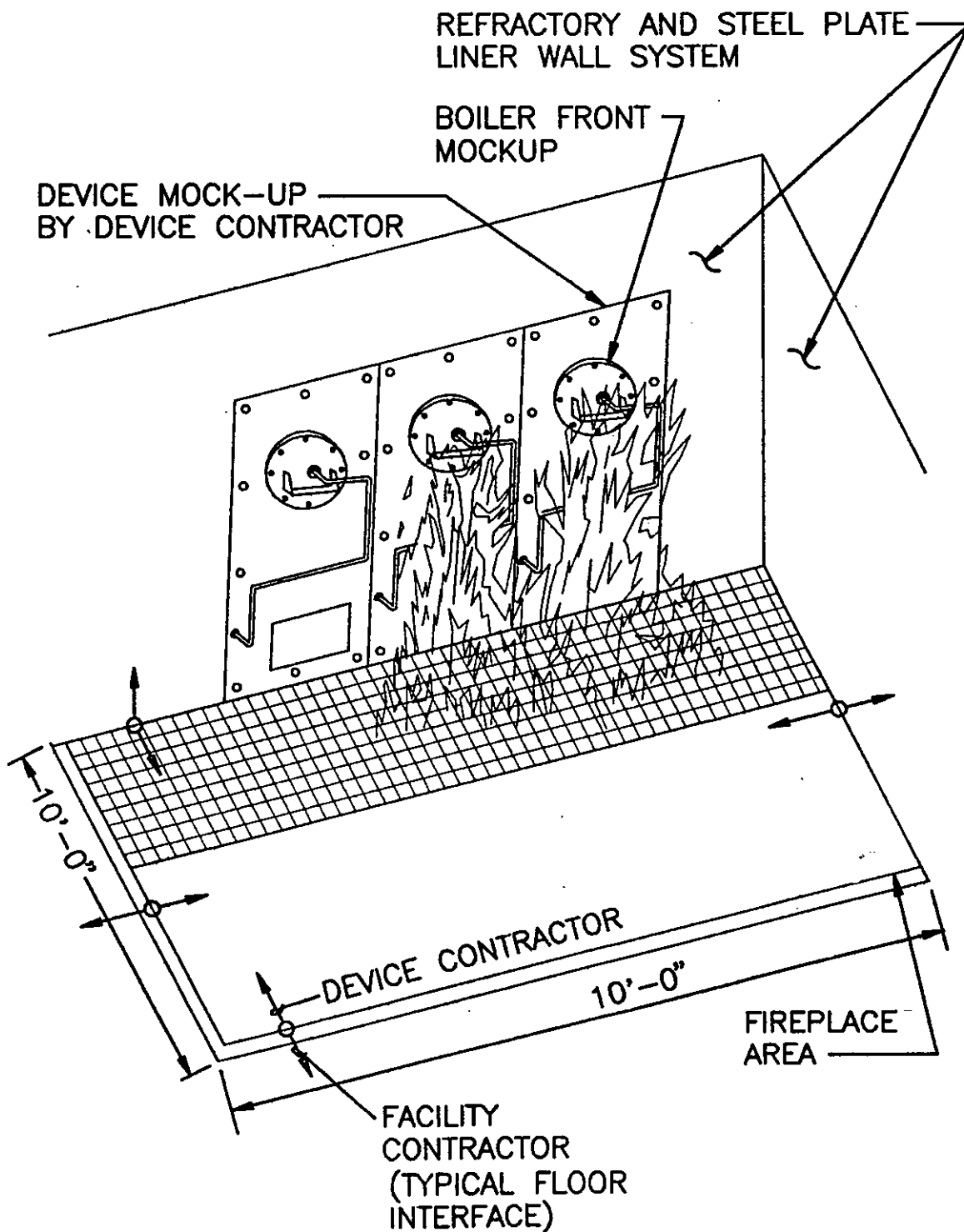

Figure A-1B
19F5, 19F5A, Bilge Fireplace

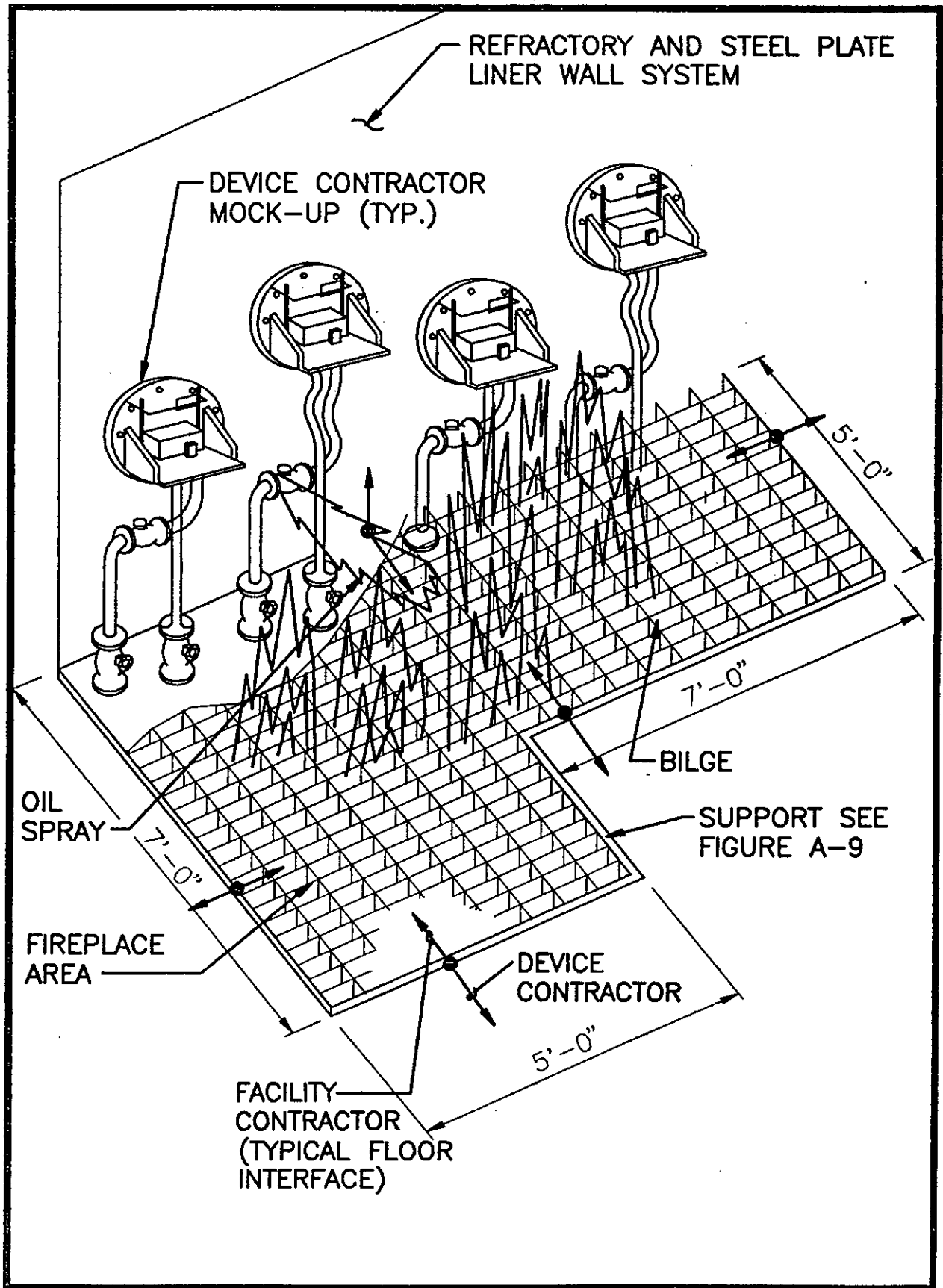

Figure A-1C
19F1A, 19F1B, 19F3, 19F3A, 19F3C
Oil Spray/Bilge Fireplace

MIL-HDBK-1027/1

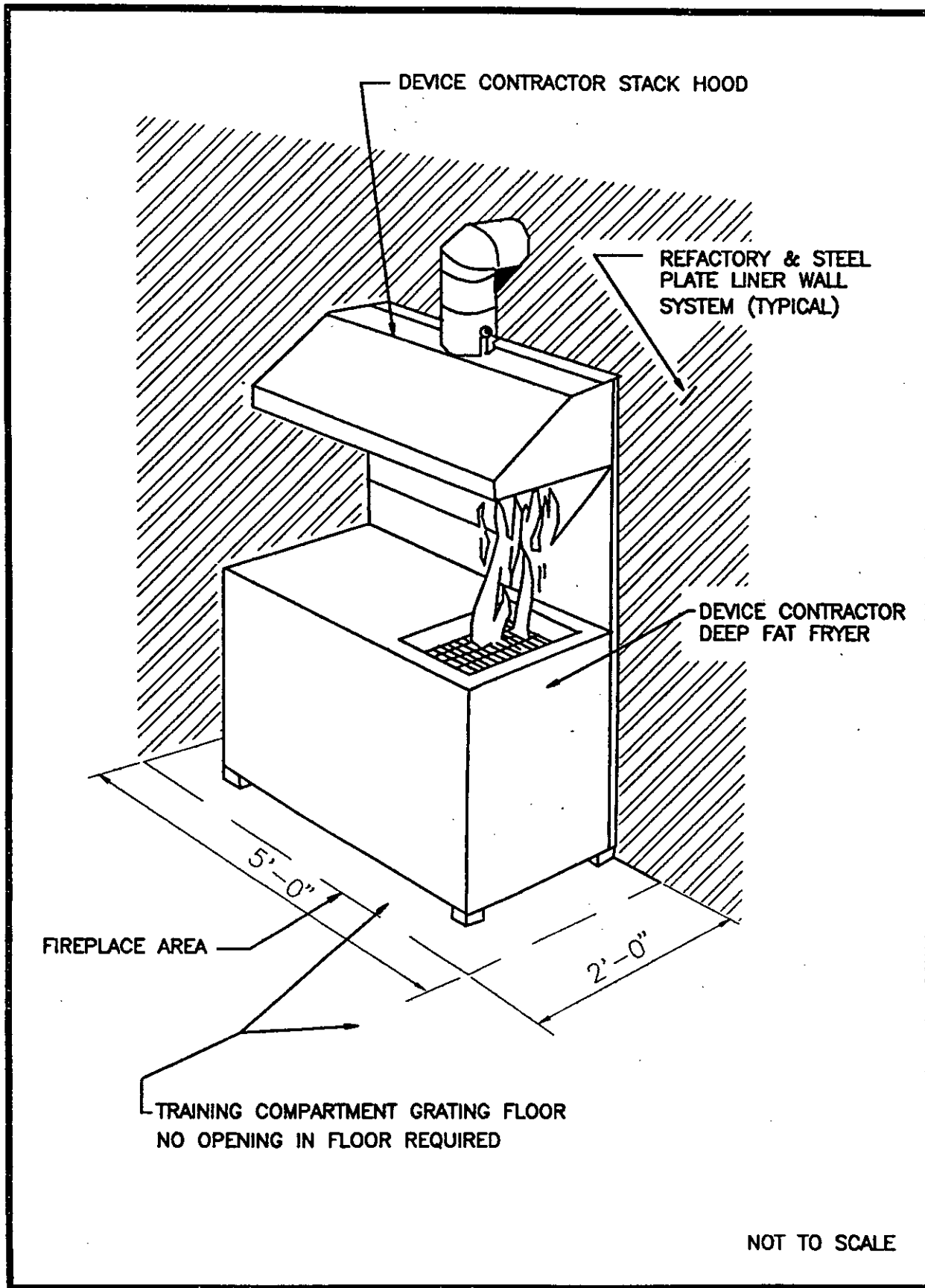

Figure A-2
Typical Deep Fat Fryer Fireplace

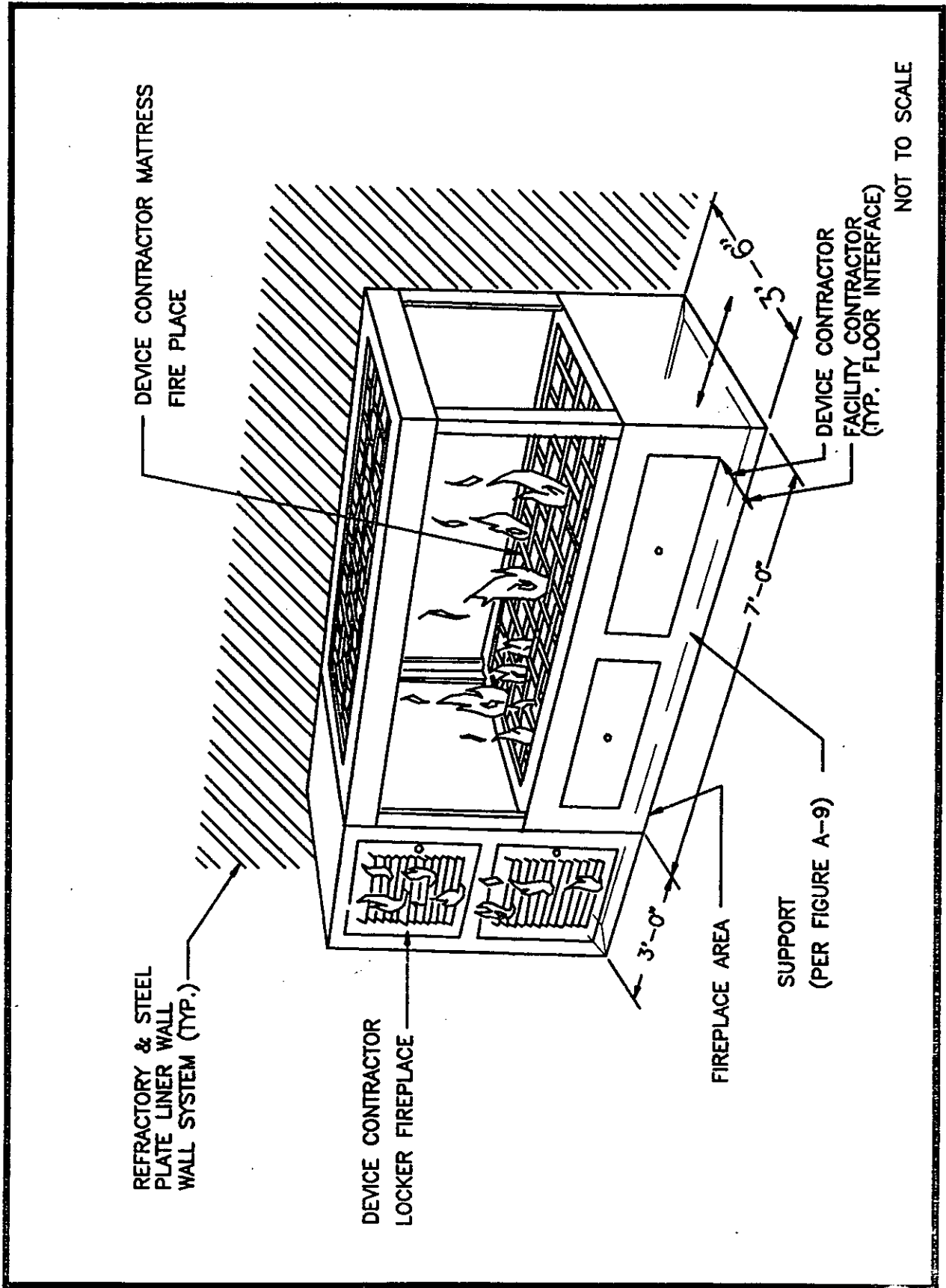

Figure A-3
Typical Mattress/Locker Fireplace

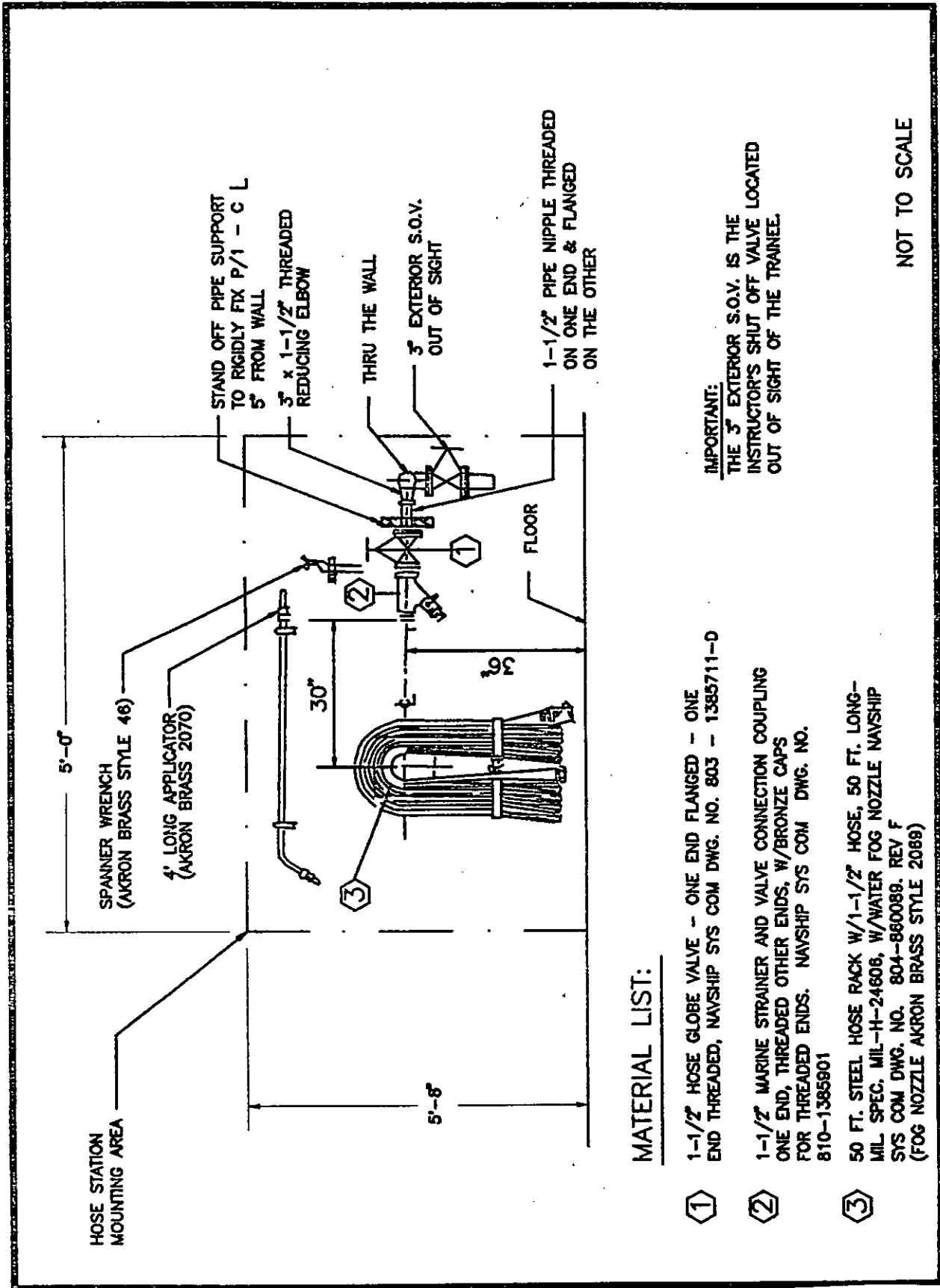
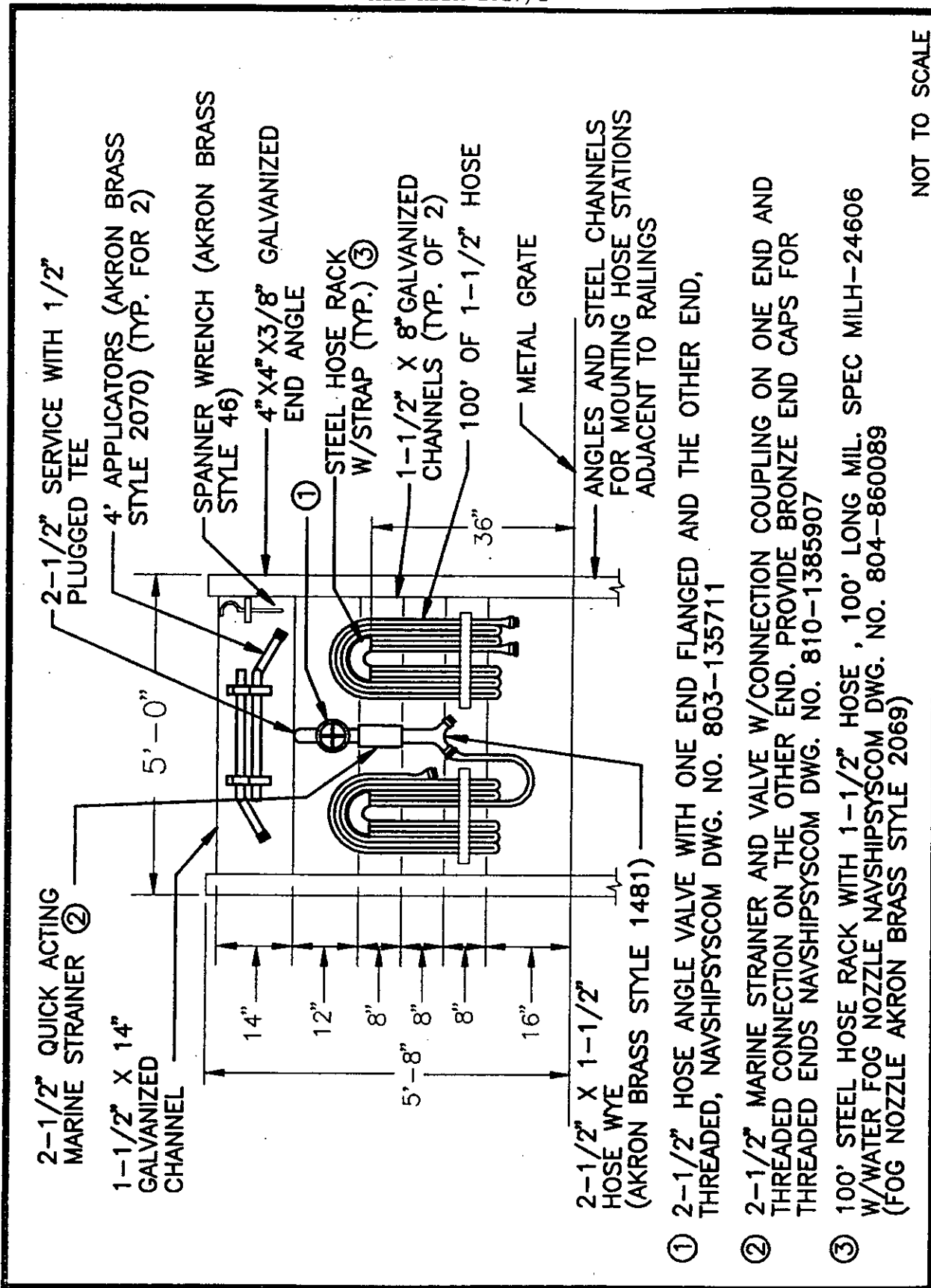

Figure A-4
Hose Station Detail HS1 - 1-1/2"



NOT TO SCALE

Figure A-5
HS2 - 2-1/2" Hose Station Detail

MIL-HDBK-1027/1

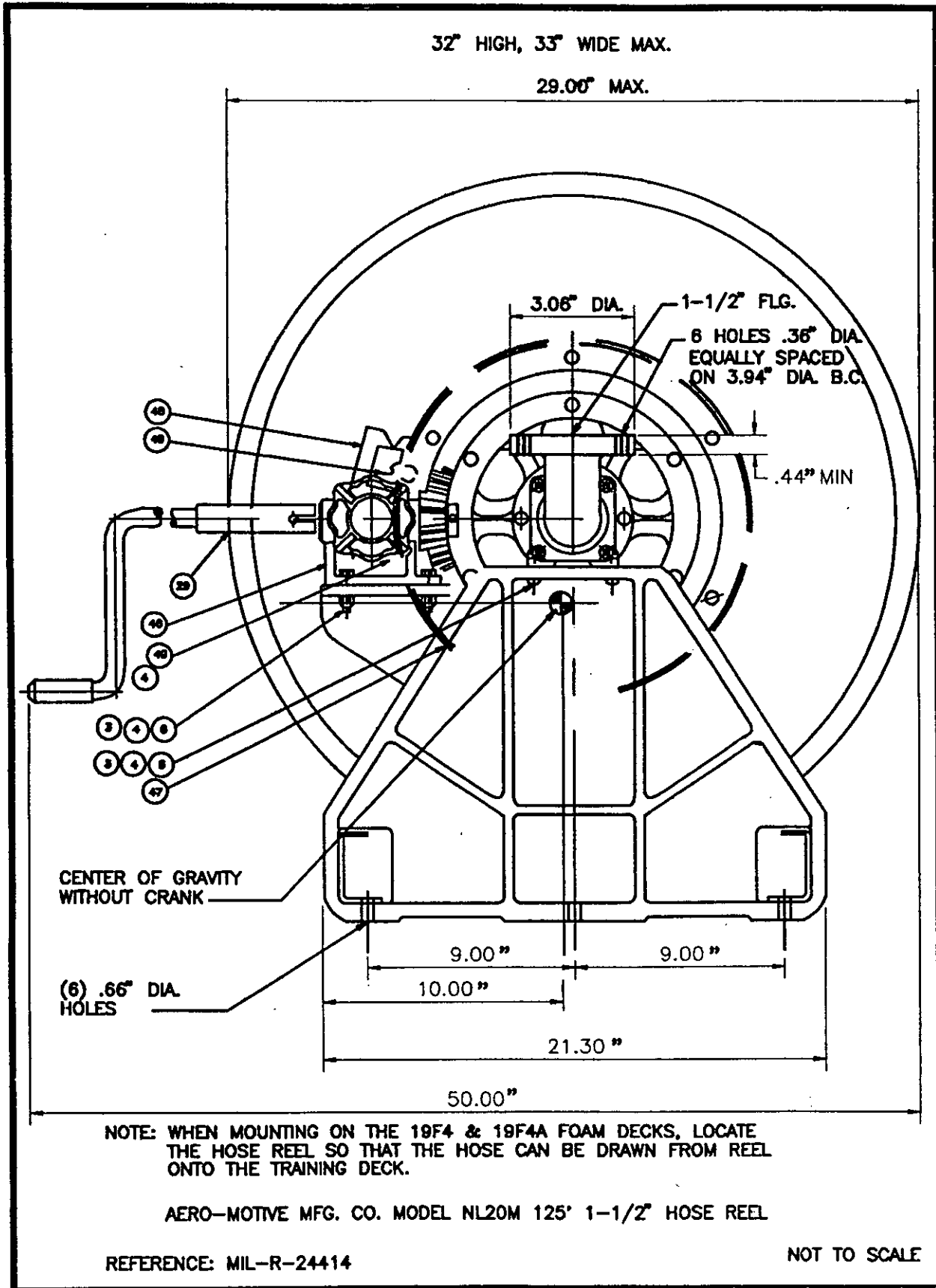
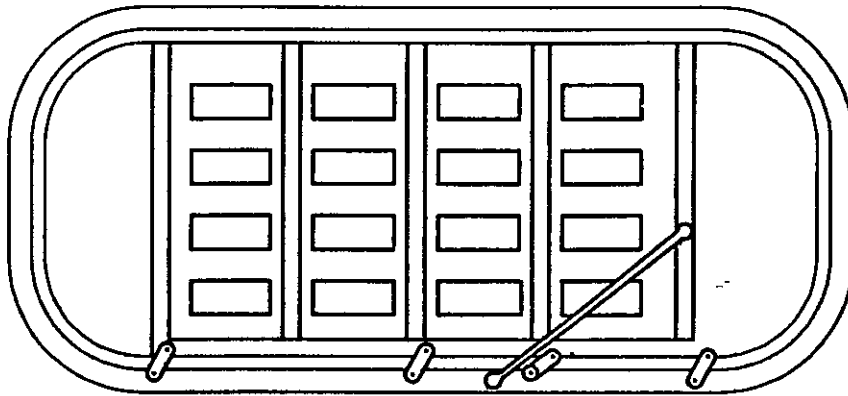
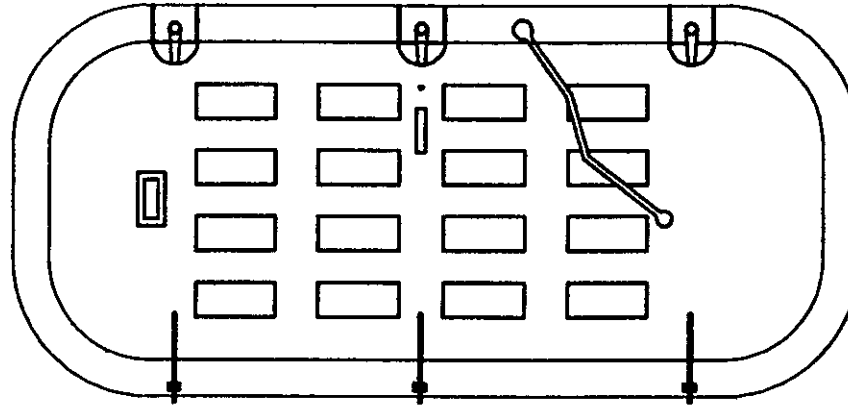

Figure A-6
AR - AFFF Hose Reel Detail

SIMULATED - QUICK ACTING WATERTIGHT DOOR
GALVANIZED STEEL, WITHOUT ASSEMBLY
NAVSHIPS DWG. 805-1400074



INSIDE VIEW



OUTSIDE VIEW

NOTE: THIS DOOR IS AN AIRTIGHT DOOR AS REQUIRED
BY NAVSHIPS DWG. NO. 805-1400074

NOT TO SCALE

Figure A-7
Quick Acting Watertight Door

MIL-HDBK-1027/1

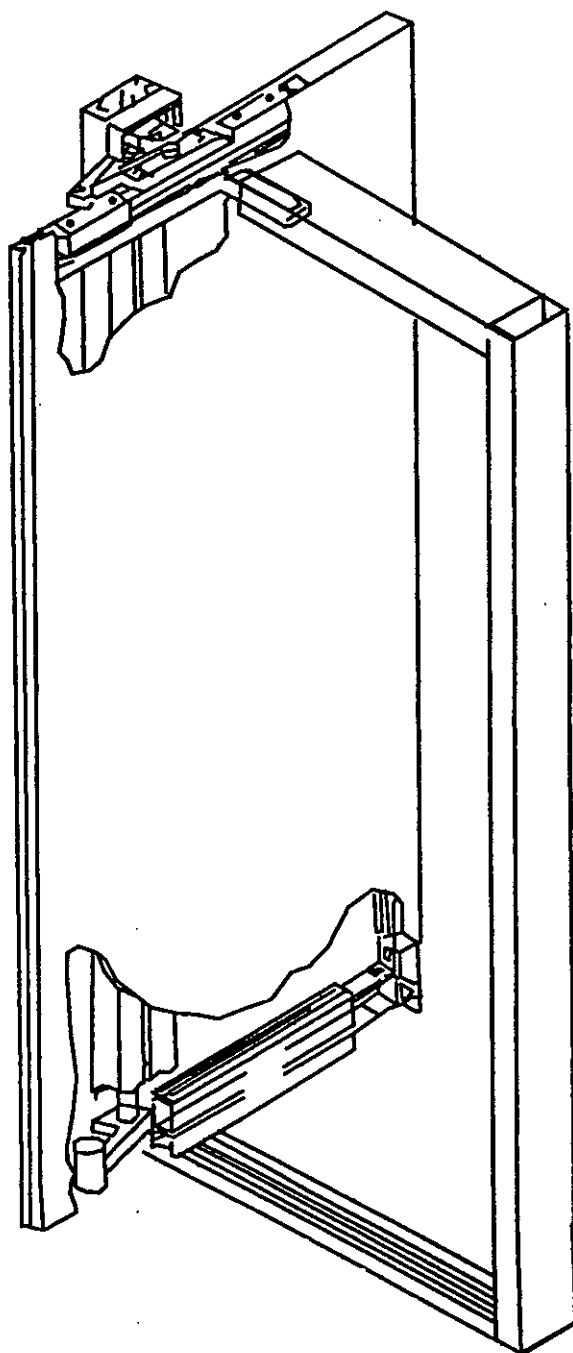

REFERENCE:
NAVSEA DWG. NO. 803-5184129:
DOOR, STEEL, BALANCED.
ELLISON BRONZE CO. INC.

NOT TO SCALE

Figure A-8
Ellison Type Door

MIL-HDBK-1027/1

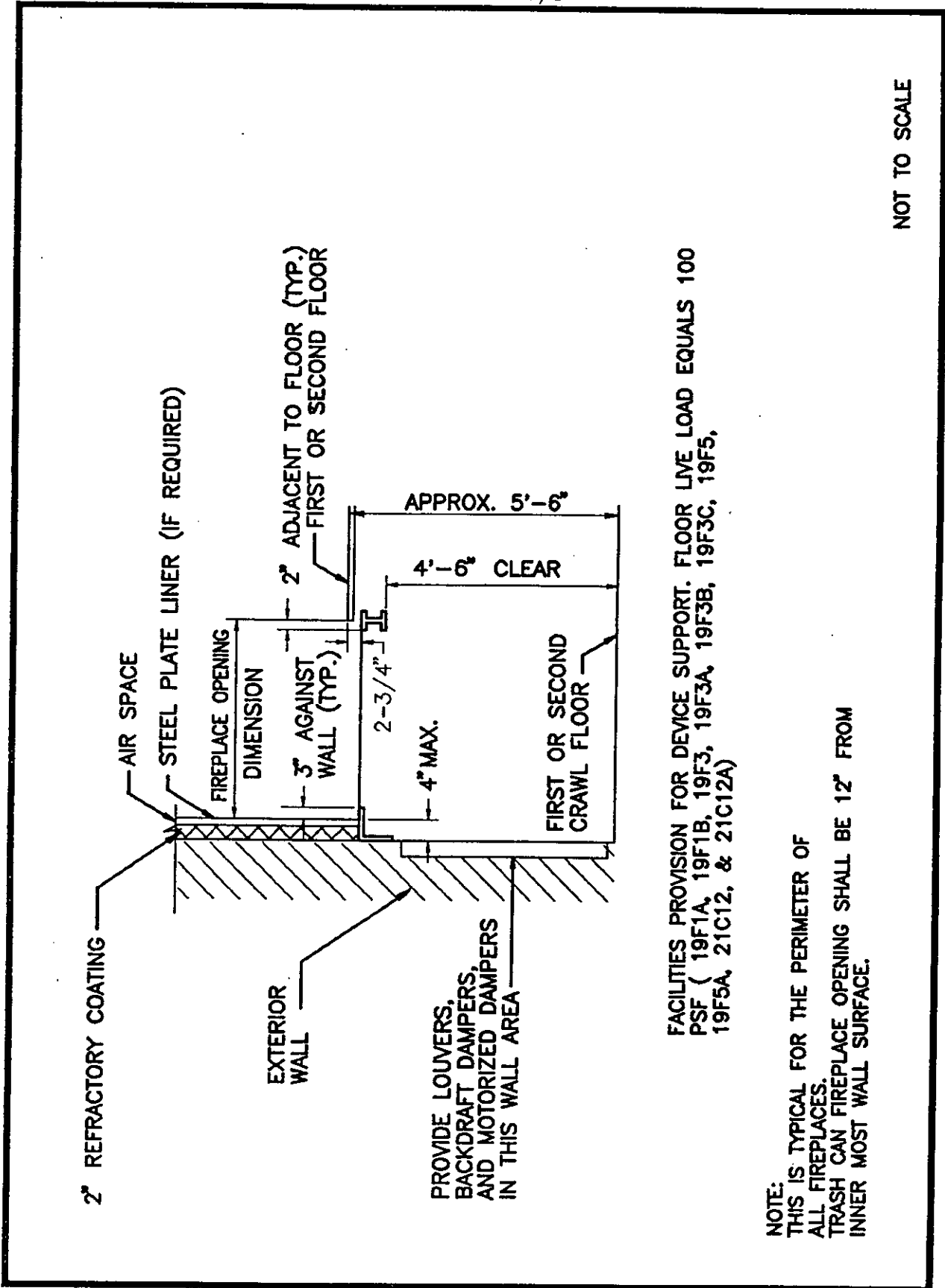
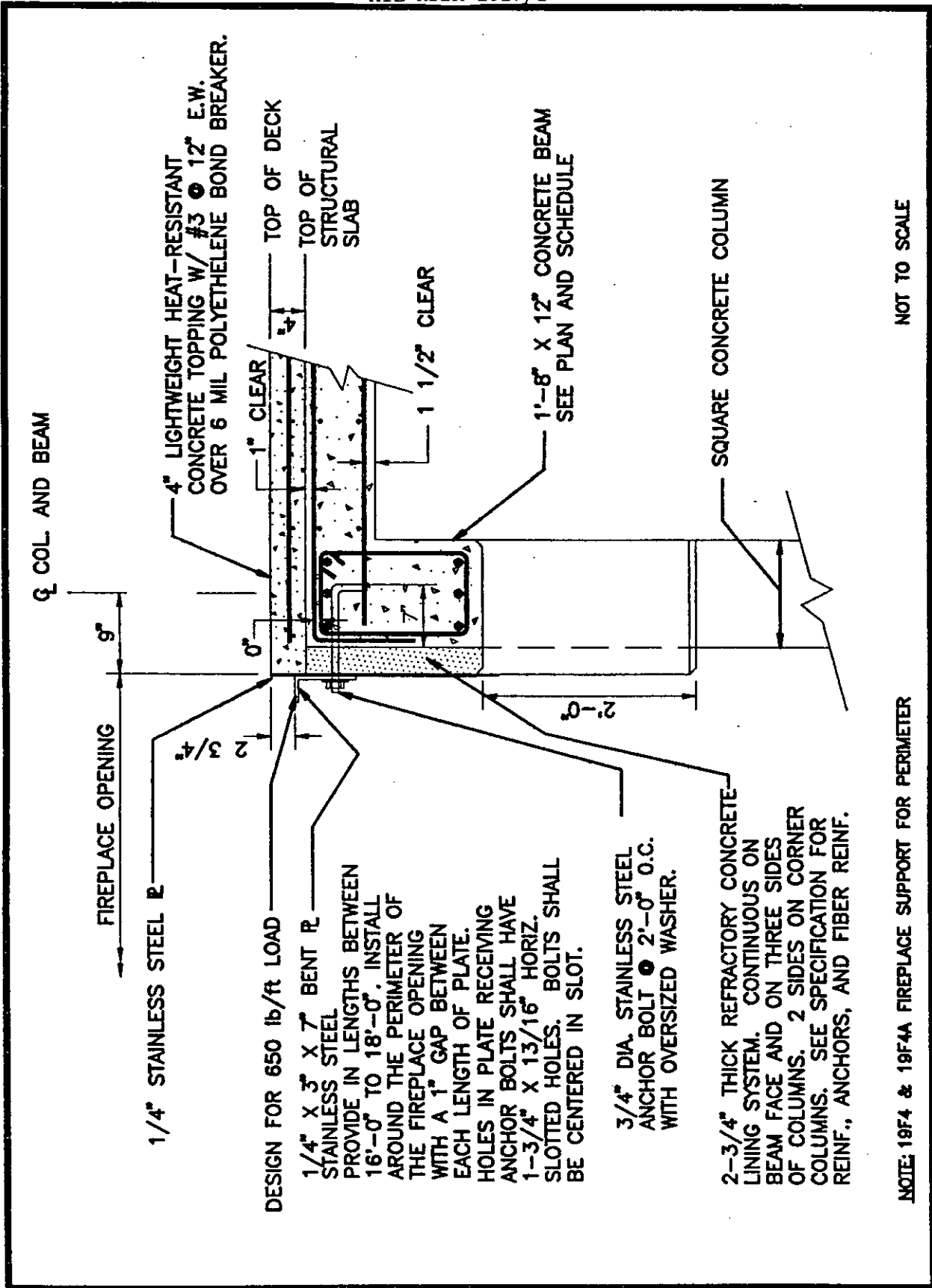

Figure A-9A
Fireplace Support



NOT TO SCALE

NOTE: 19F4 & 19F4A FIREPLACE SUPPORT FOR PERIMETER

Figure A-9B
Fireplace Support

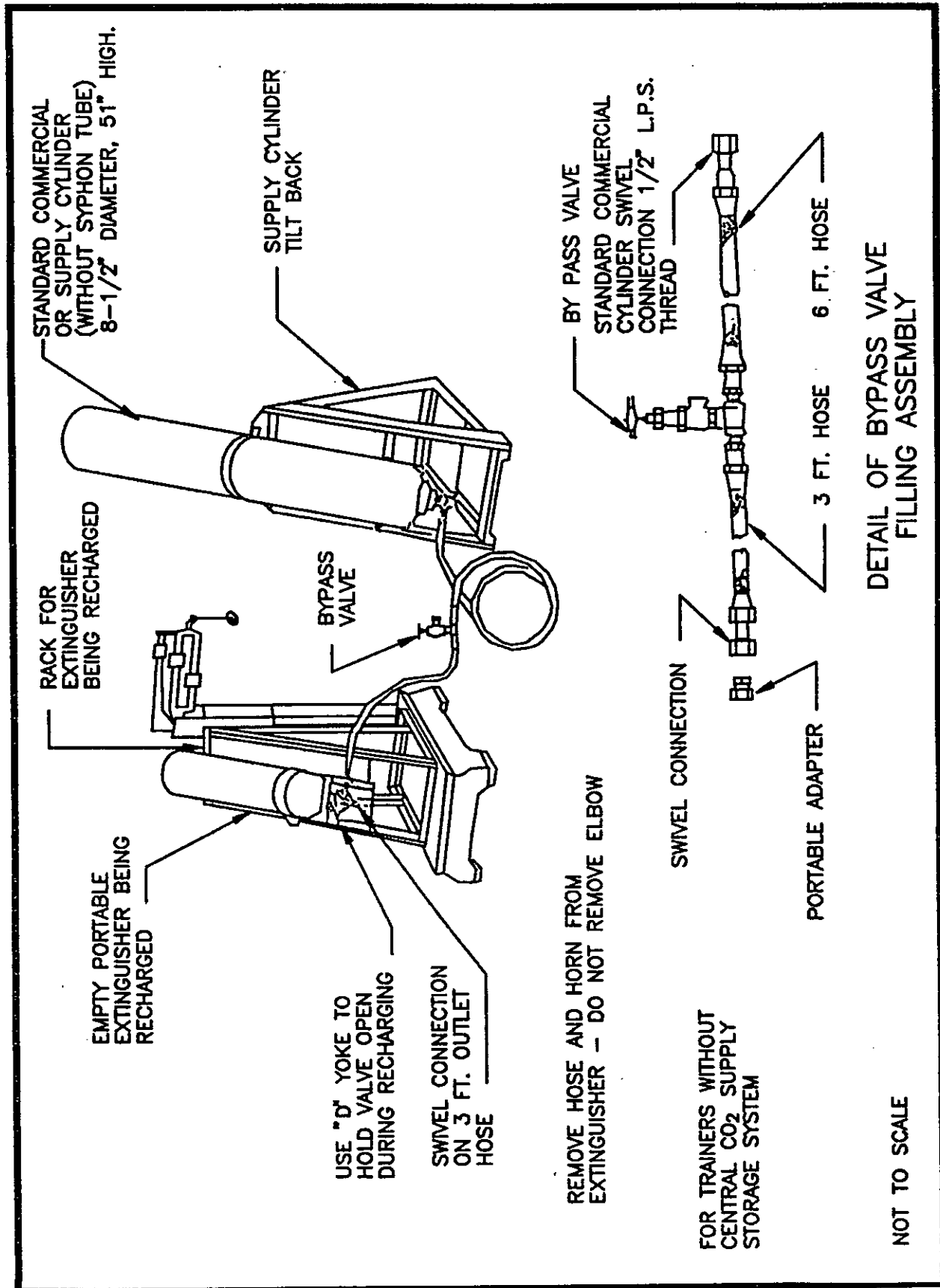

Figure A-11
Recharging Tilt Rack and Fill Equipment

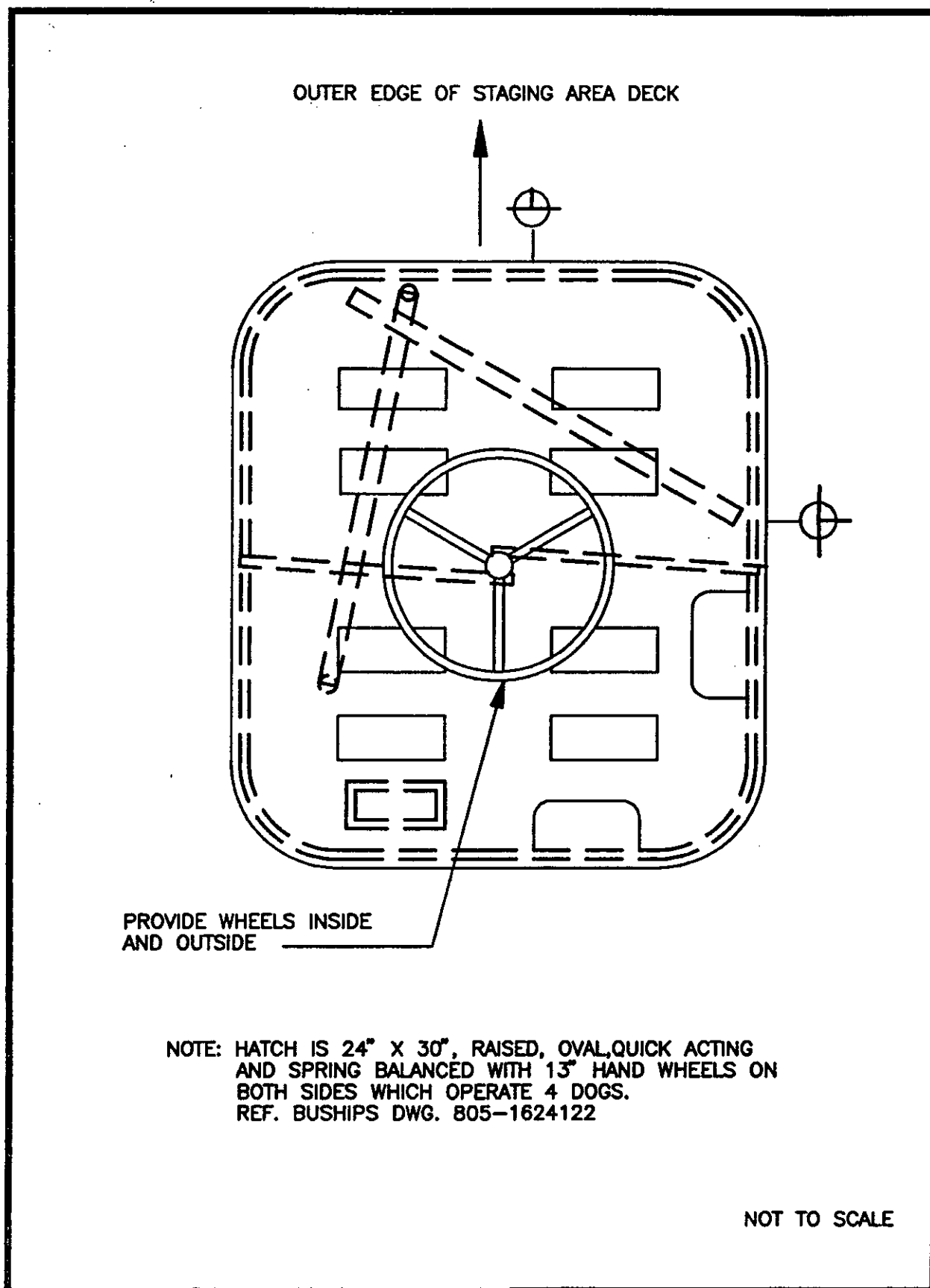

Figure A-12
Watertight Hatch for Emergency Escape Trunk

MIL-HDBK-1027/1

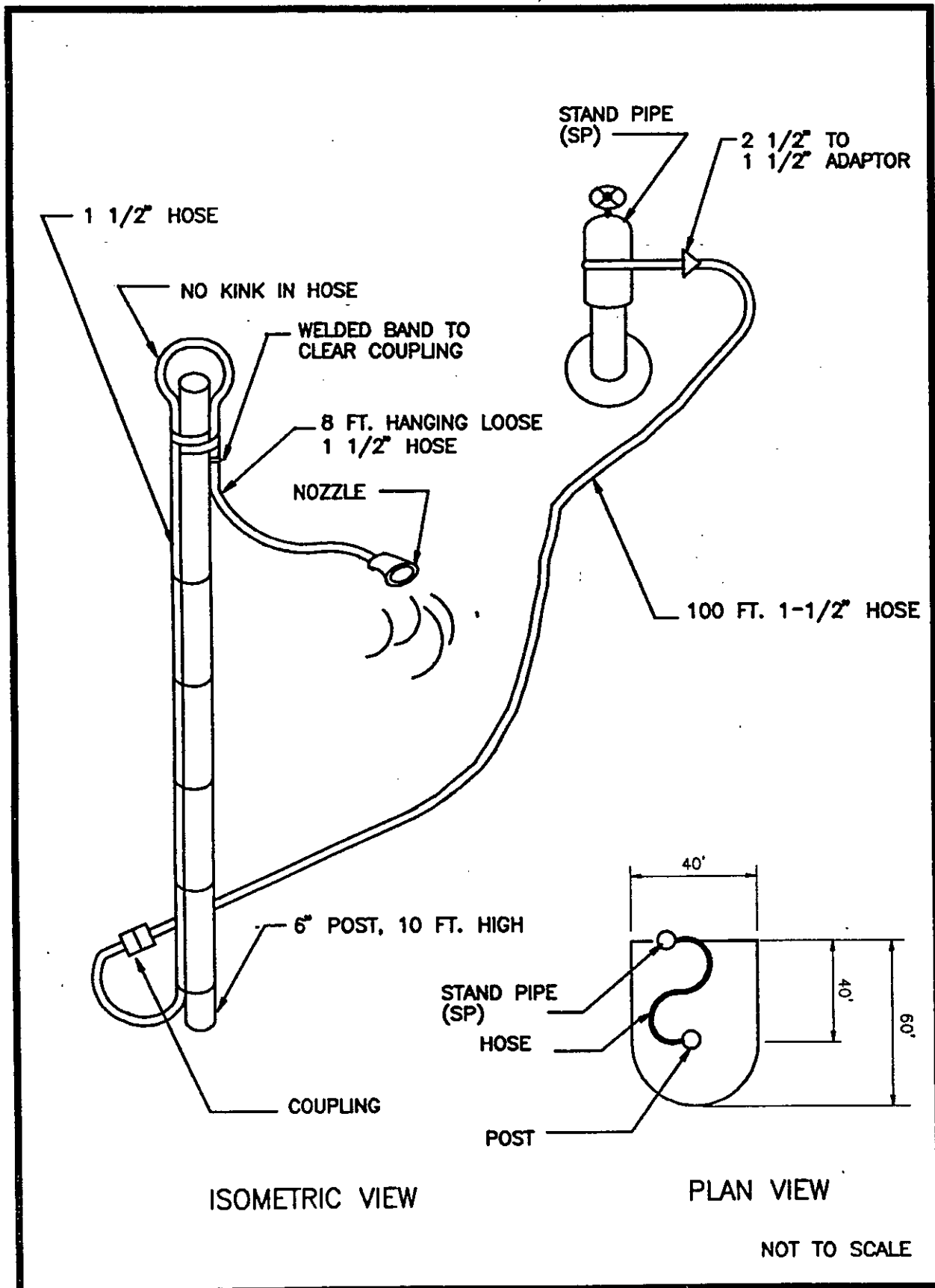

Figure A-13A
Wild Hose Demonstration Facility

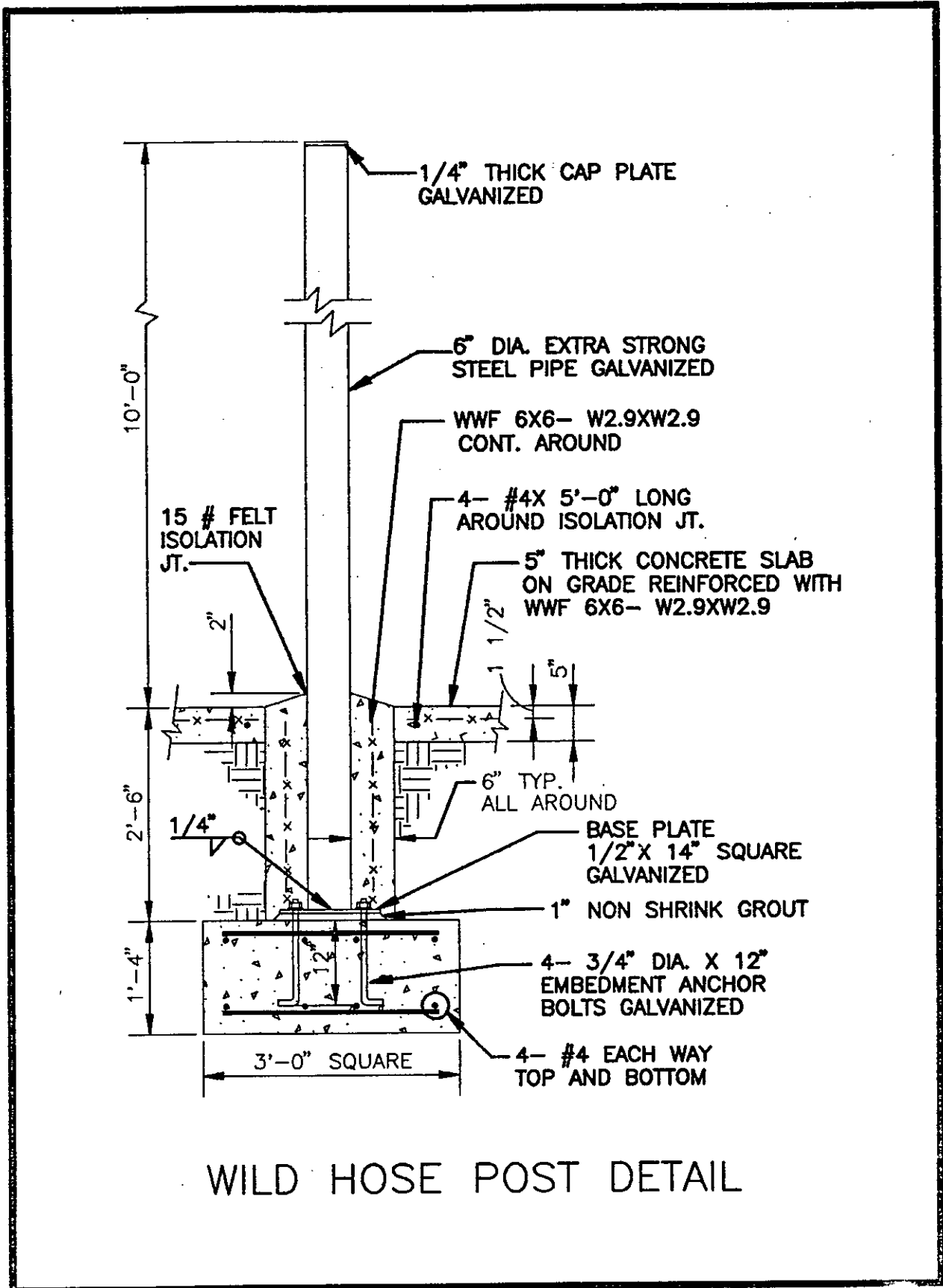

Figure A-13B
Wild Hose Post Detail

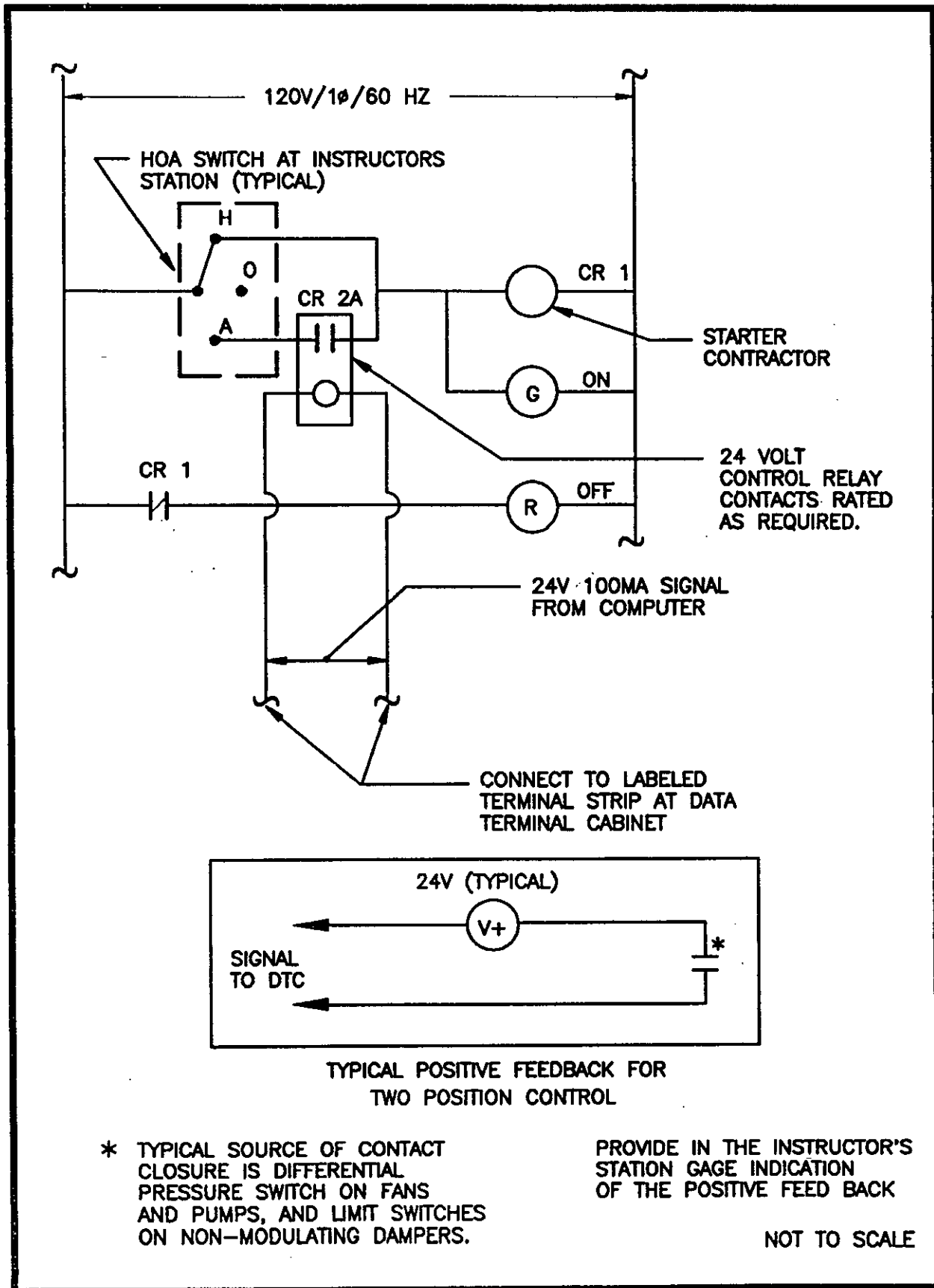

Figure A-14
Two Position Control Interface

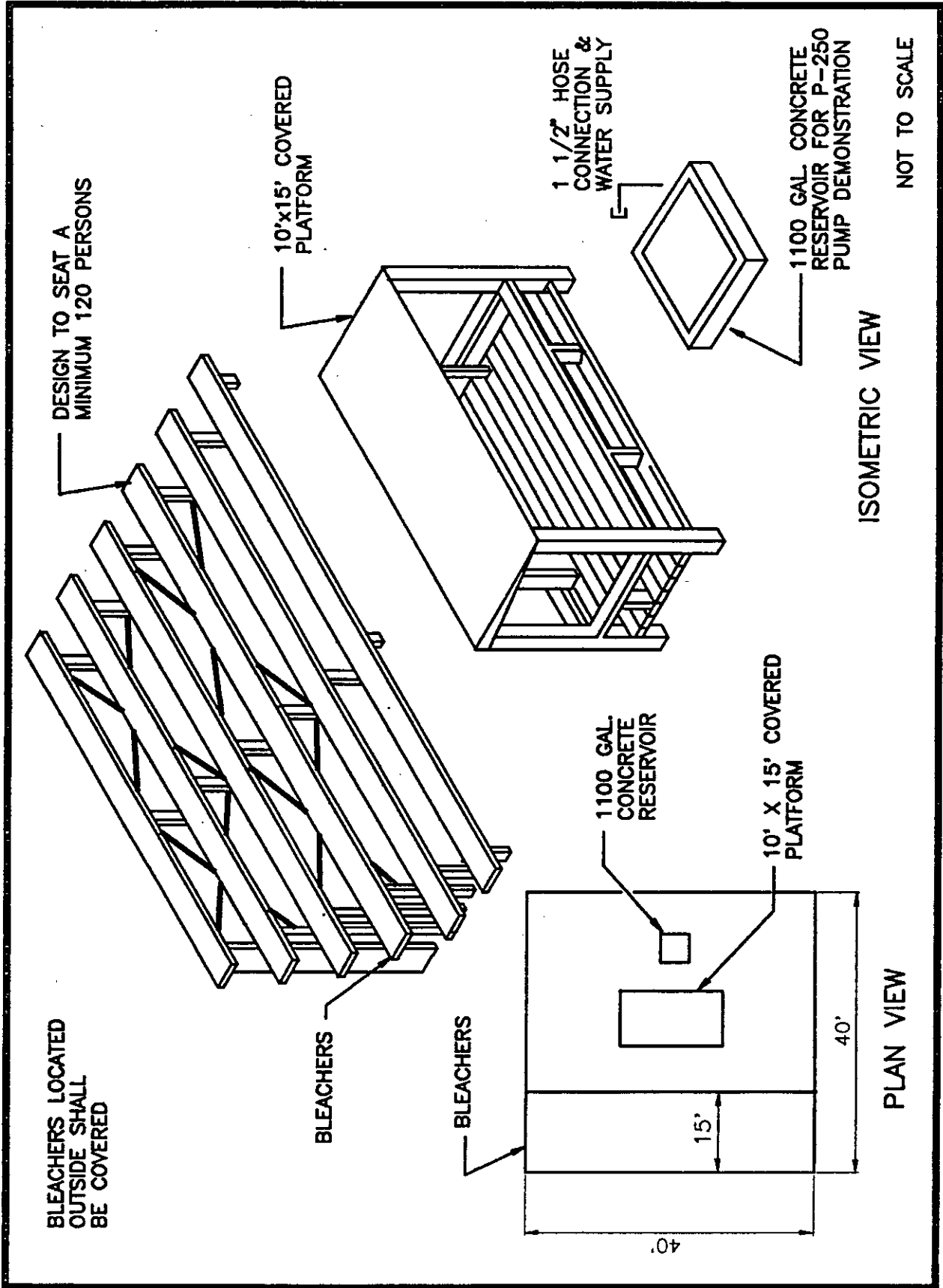

Figure A-15
Portable Pump P-250 Demonstration Facility

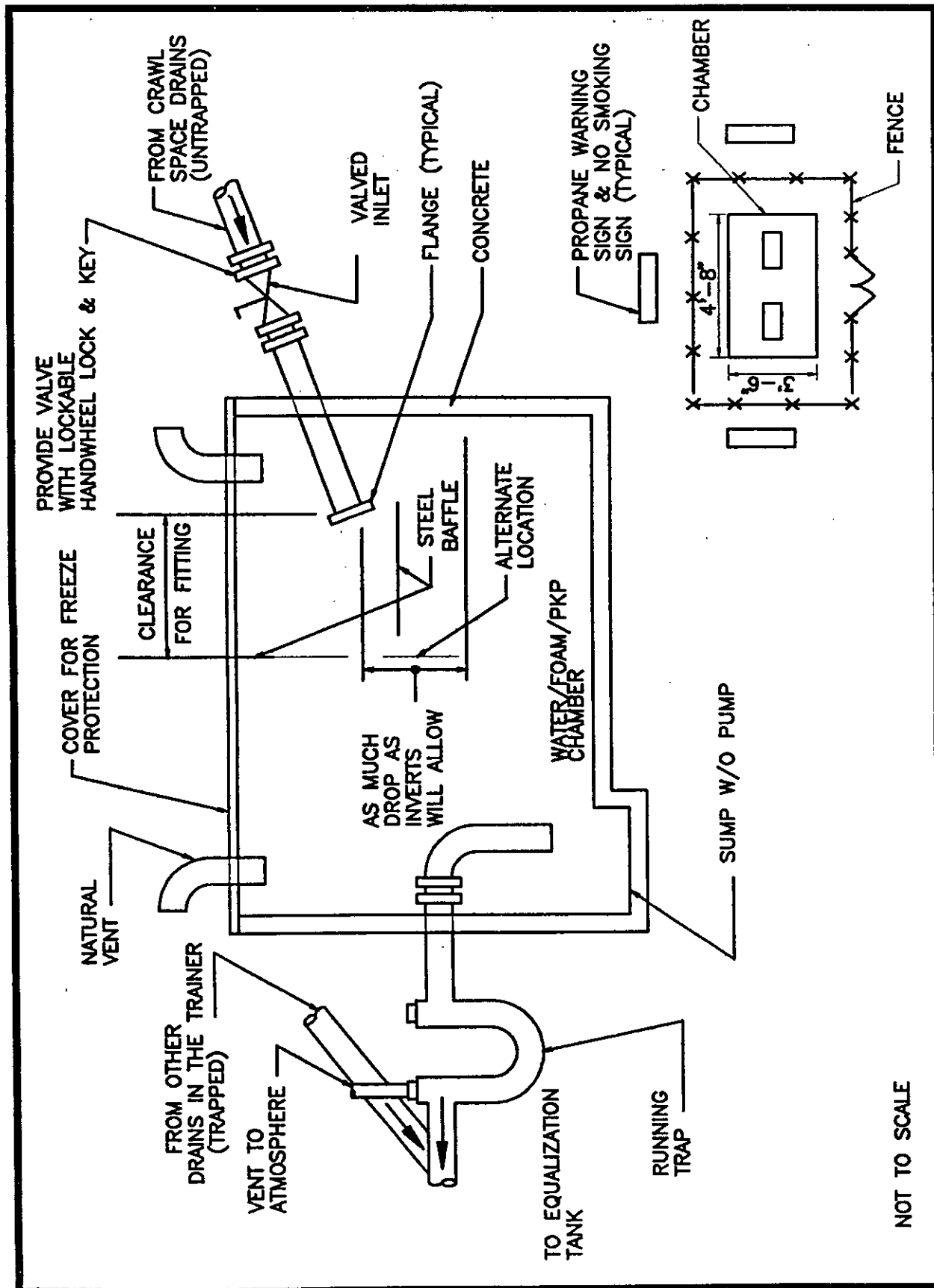

Figure A-16
Separation Chamber, 21C12 and 19F Series Devices

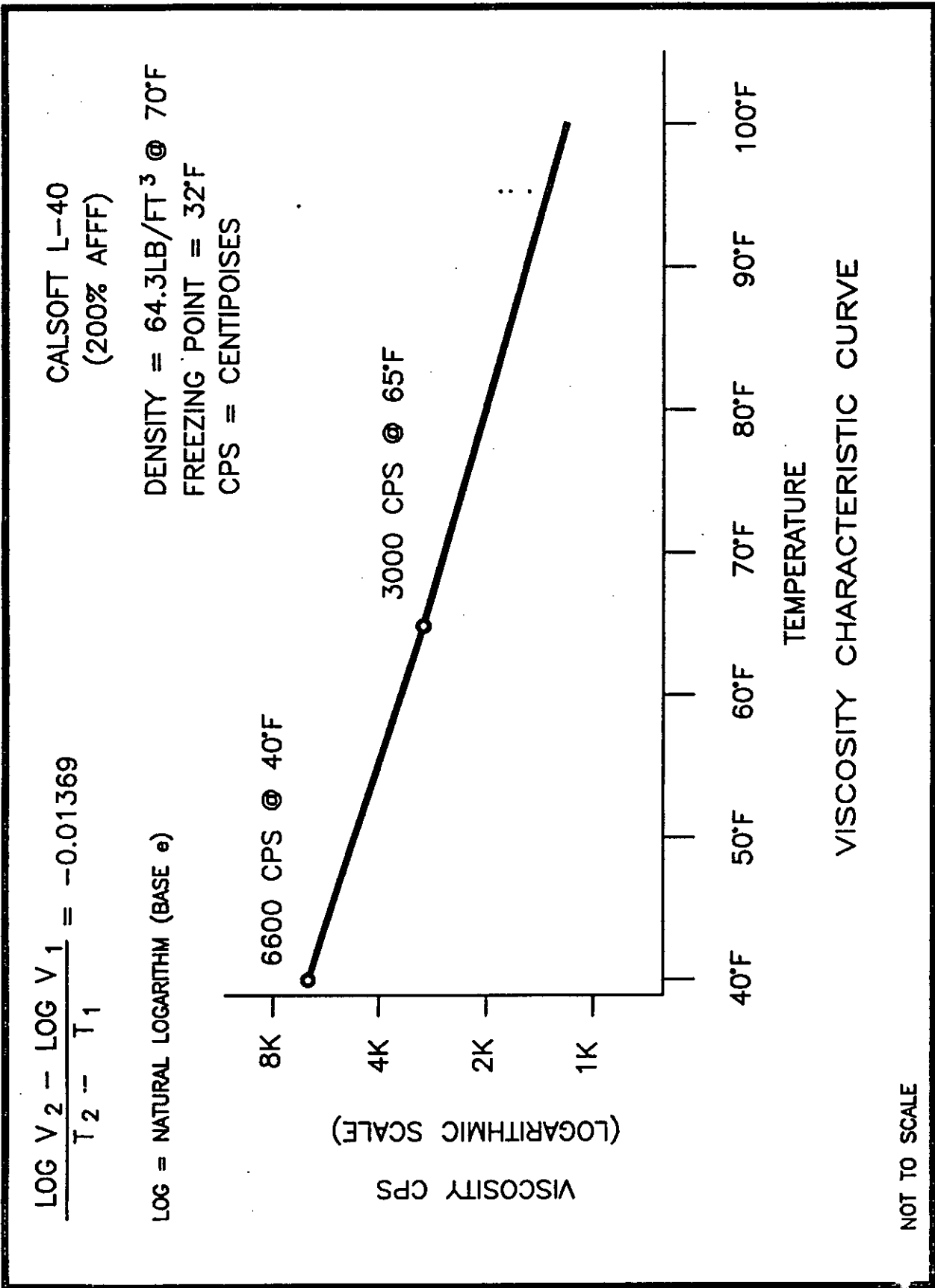

Figure A-17
 Calsoft L-40 Viscosity Characteristic Curve

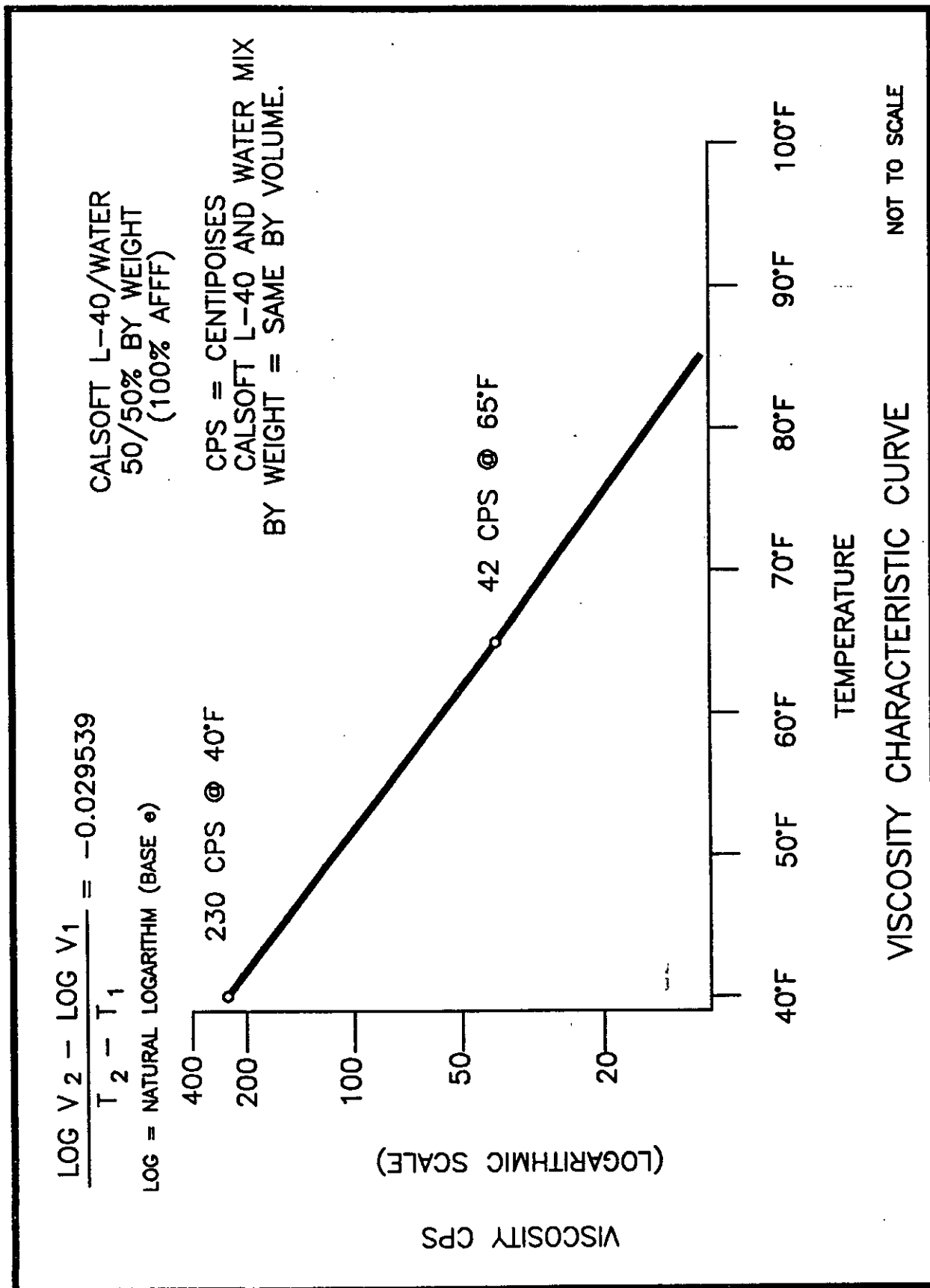

Figure A-18
 Calsoft L-40/Water Viscosity Characteristic Curve

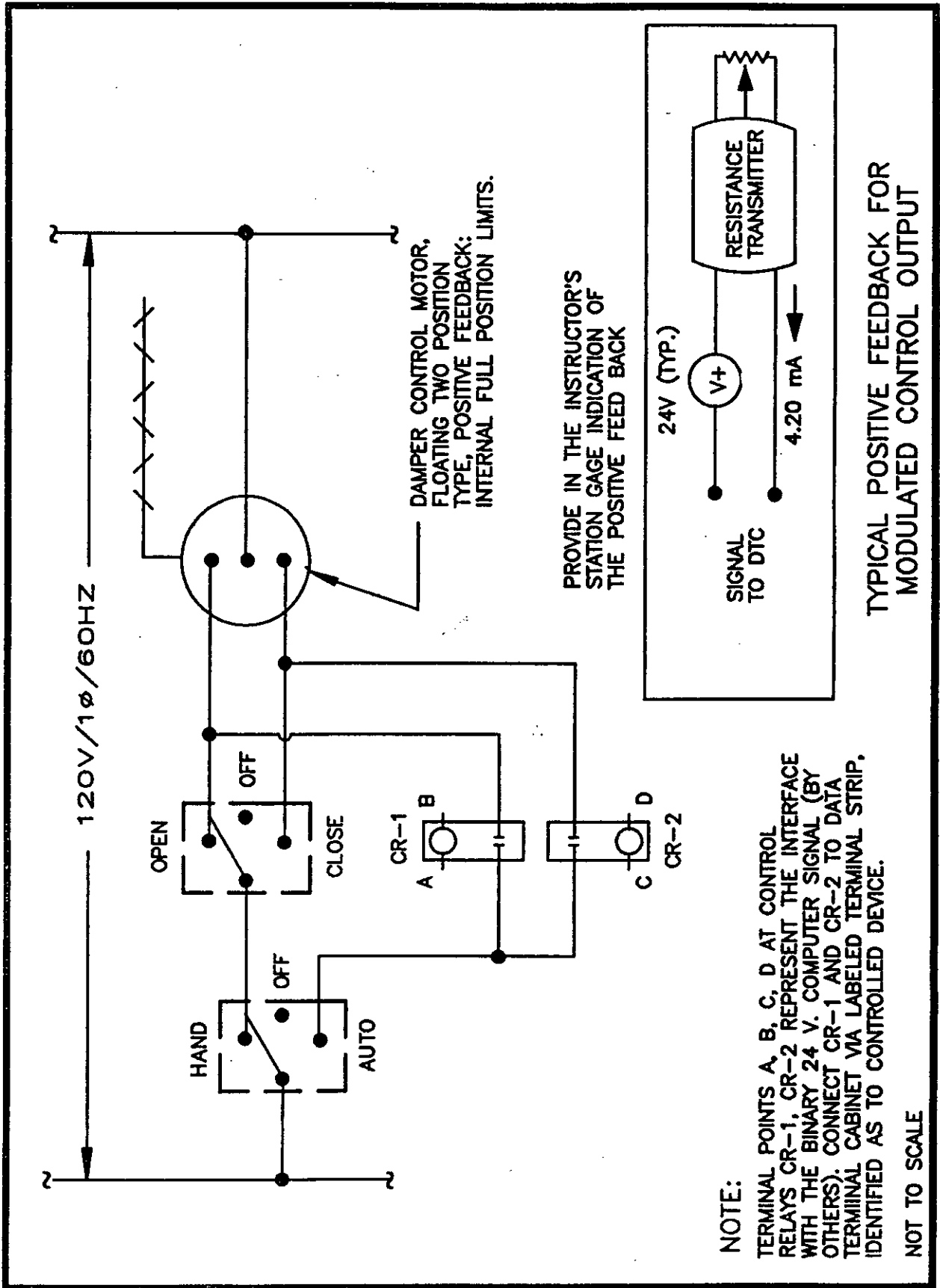
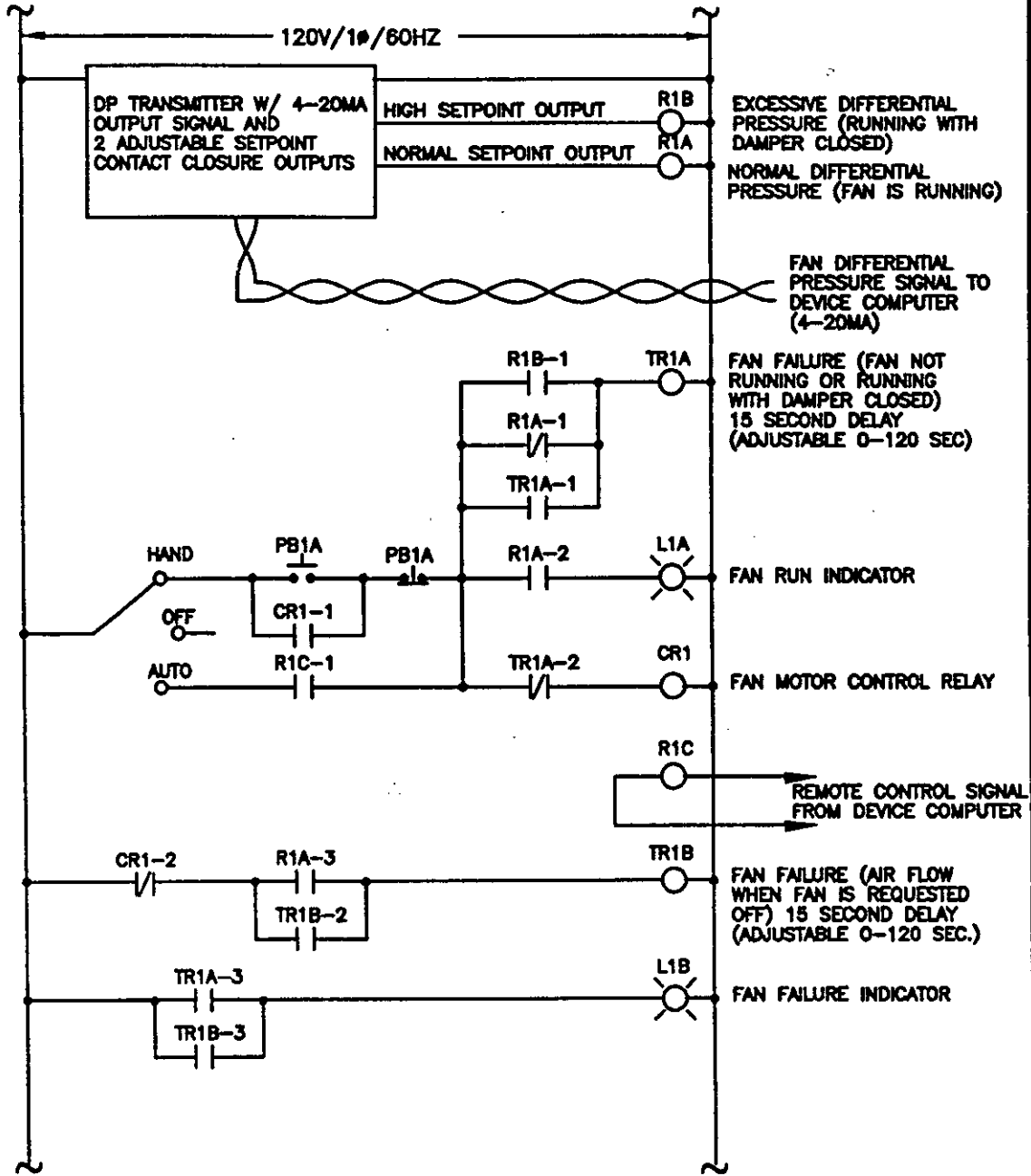

Figure A-19
 Floating Point Control Interface

EXHAUST FAN/CRAWL SPACE POWER CONTROLS & INTERLOCKS



EXHAUST FAN #1 CONTROL LOGIC (TYPICAL FOR FAN #2)

NOT TO SCALE

Figure A-20A
Exhaust Fan/Crawl Space Power Controls & Interlocks

MIL-HDBK-1027/1

EXHAUST FAN SEQUENCE OF OPERATION:

HAND MODE: WHEN THE START PUSHBUTTON, PB1A (PB2A), IS PRESSED, THE FAN CONTROL RELAY, CR1 (CR2), ENERGIZES AND LATCHES IN THE CIRCUIT. AS THE FAN COMES UP TO SPEED, MINIMUM AIRFLOW DIFFERENTIAL PRESSURE IS GENERATED, ACTIVATING R1A (R2A). THIS CAUSES THE RUN INDICATOR, L1A (L2A) TO LIGHT. PRESSING THE STOP BUTTON, PB1B (PB2B), UNLATCHES THE CIRCUIT WHICH DEENERGIZES THE FAN CONTROL RELAY AND RUN INDICATOR.

AUTO MODE: WHEN THE REMOTE CONTROL RELAY, R1C (R2C), IS ENERGIZED, THE FAN CONTROL RELAY, CR1 (CR2), IS ALSO ENERGIZED. AS THE FAN COMES UP TO SPEED, MINIMUM AIRFLOW DIFFERENTIAL PRESSURE IS GENERATED, ACTIVATING R1A (R2A). THIS CAUSES THE RUN INDICATOR, L1A (L2A) TO LIGHT. DEENERGIZING THE DEVICE COMPUTER CONTROL RELAY RELEASES THE FAN CONTROL RELAY AND TURNS OFF THE RUN INDICATOR.

INTERLOCKS & ALARMS (HAND AND AUTO MODES): IF NORMAL DIFFERENTIAL PRESSURE IS SENSED (FAN IS RUNNING), RELAY R1A (R2A) IS ENERGIZED. EXCESSIVE DIFFERENTIAL PRESSURE (FAN RUNNING WITH DAMPER CLOSED) CAUSES R1B (R2B) TO ENERGIZE. WHEN THE FAN IS COMMANDED ON AND EITHER INSUFFICIENT OR EXCESSIVE DIFFERENTIAL PRESSURE IS SENSED FOR 15 SECONDS, RELAY TR1A (TR2A) ENERGIZES AND LATCHES IN. THIS DEENERGIZES THE FAN CONTROL RELAY, CR1 (CR2) AND LIGHTS THE FAN FAILURE INDICATOR, L1B (L2B). WHEN THE FAN IS COMMANDED OFF AND NORMAL DIFFERENTIAL PRESSURE IS SENSED FOR 15 SECONDS, RELAY TR1B (TR2B) ENERGIZES AND LATCHES IN. THIS ALSO CAUSES INDICATOR L1B (L2B) TO LIGHT.

- NOTES:
1. DEVICE TAGS SHOWN IN PARENTHESIS IN THE SEQUENCE OF OPERATION REFER TO EXHAUST FAN #2 CONTROL DEVICES.
 2. CONTROL LOGIC MAY BE IMPLEMENTED IN DISCRETE HARDWARE OR IN A SMALL PROGRAMMABLE LOGIC CONTROLLER.
 3. TIMER RELAYS PROVIDE A DELAY AS NOTED AFTER POWER IS APPLIED. WHEN POWER IS REMOVED THE CONTACTS RESET IMMEDIATELY.

Figure A-20B
Exhaust Fan/Crawl Space Power Controls & Interlocks

EXHAUST FAN/CRAWL SPACE POWER CONTROLS & INTERLOCKS

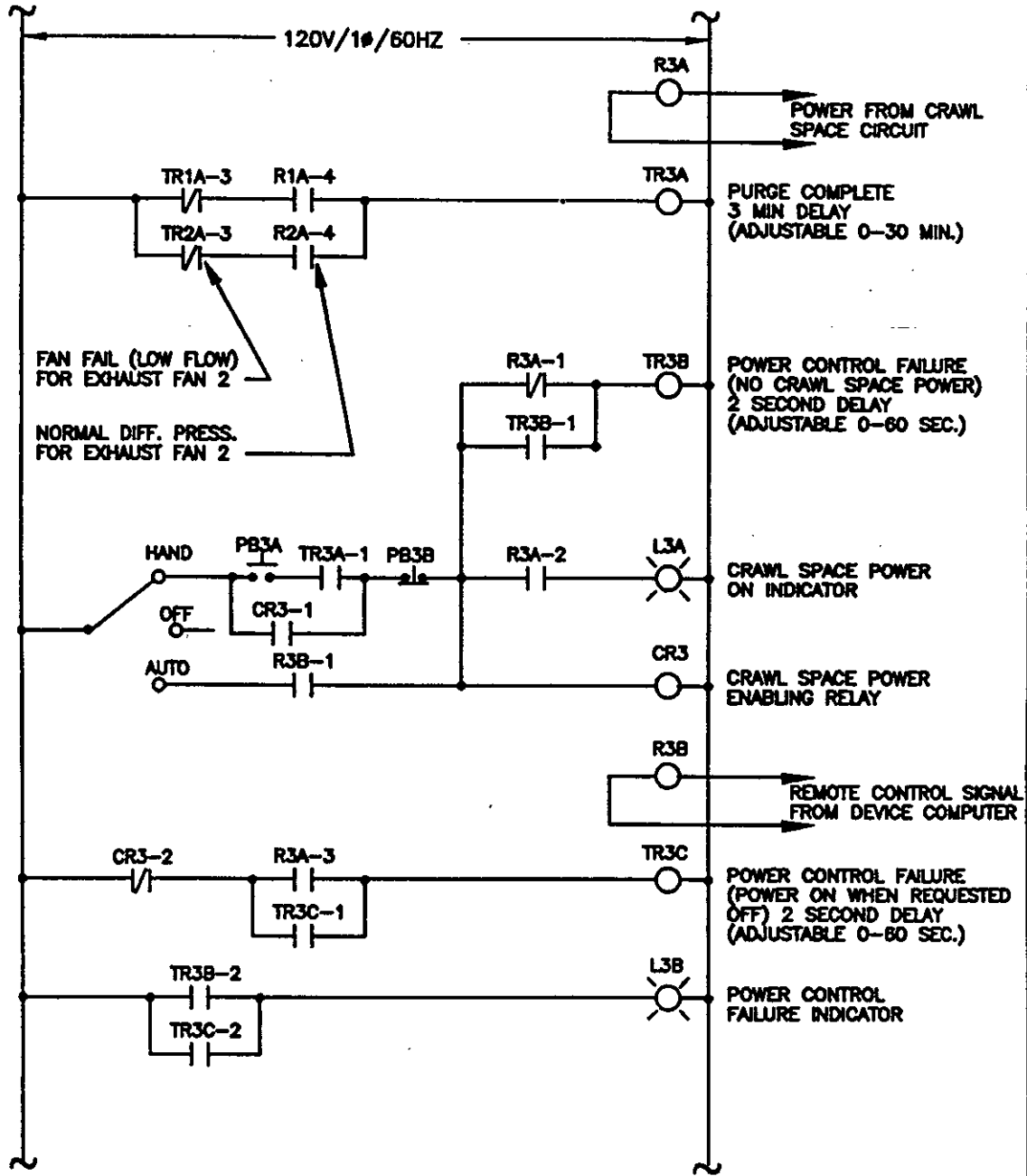

CRAWL SPACE POWER CONTROL LOGIC

NOT TO SCALE

Figure A-20C
Exhaust Fan/Crawl Space Poser Controls & Interlocks

MIL-HDBK-1027/1

CRAWL SPACE POWER SEQUENCE OF OPERATION:

HAND MODE: WHEN EITHER FAN IS ON FOR 10 MINUTES WITHOUT A DETECTED FAILURE, THE PURGE COMPLETE RELAY, TR3A, IS ENERGIZED. WHEN THE ON PUSHBUTTON, PB3B, IS PRESSED AND TR3A IS ENERGIZED, THE CRAWL SPACE POWER RELAY, CR3, ENERGIZES AND LATCHES IN THE CIRCUIT. THIS PROVIDES POWER TO THE CRAWL SPACE, ENERGIZING RELAY R3A AND LIGHTING THE POWER INDICATOR, L3A. PRESSING THE OFF PUSHBUTTON, PB3B, UNLATCHES THE CIRCUIT WHICH DEENERGIZES THE POWER CONTROL RELAY AND POWER INDICATOR.

AUTO MODE: WHEN THE REMOTE CONTROL RELAY, R3B, IS ENERGIZED, THE FAN CONTROL RELAY, CR3, IS ALSO ENERGIZED. THIS PROVIDES POWER TO THE CRAWL SPACE, ENERGIZING RELAY R3A AND LIGHTING THE POWER INDICATOR, L3A. WHEN THE DEVICE COMPUTER CONTROL RELAY RELEASES, THE CRAWL SPACE POWER RELAY AND INDICATOR DEENERGIZE.

ALARMS (HAND AND AUTO): IF RELAY R3A DOES NOT ENERGIZE WITHIN 2 SECONDS AFTER POWER IS COMMANDED ON, POWER FAILURE RELAY TR3B ENERGIZES AND LATCHES ON. IF RELAY R3A DOES NOT DEENERGIZE WITHING 2 SECONDS AFTER POWER IS COMMANDED OFF, POWER FAILURE RELAY TR3C ENERGIZES AND LATCHES ON. WHENEVER EITHER POWER FAILURE RELAY IS COMMANDED THE POWER CONTROL FAILURE INDICATOR, L3B, LIGHTS.









- NOTES:
1. CONTROL LOGIC MAY BE IMPLEMENTED IN DISCRETE HARDWARE OR IN A SMALL PROGRAMMABLE LOGIC CONTROLLER.
 2. TIMER RELAYS PROVIDE A DELAY AS NOTED AFTER POWER IS APPLIED. WHEN POWER IS REMOVED THE CONTACTS RESET IMMEDIATELY.

Figure A-20D
Exhaust Fan/Crawl Space Power Controls & Interlocks

MIL-HDBK-1027/1

AFFF STATION

EQUIPMENT IDENTIFICATION			
NO	DESCRIPTION	REFERENCE	SOURCE OF SUPPLY
(1)	GATE VALVE		STANDARD COMM.-300 PSI WOG
(2)	WATER MAIN CONT. VALVE TO STATION (HYCHECK)	MIL-F-20042	CLAVAL MOD. 18M-EP/181M-EPKH
(3)	AFFF CONCENTRATE DISCHARGE CONT. VALVE (POWER CHECK)	MIL-F-20042	CLAVAL MOD. 181PM-EP
(4)	BACK PRESS. REGULATING VALVE	MIL-V-15508	FEECON PART 00875040
(5)	MASTER SOPV (SOL OPERATED PILOT VALVE)	MIL-V-15508	CLAVAL MODEL CSM5M-3A
(6)	PUMP (35 GPM @ 200 PSIG HEAD)	MIL-P-19131	BLACKMER PUMP MODEL BXL-11/4
(7)	PUSHBUTTON STATION		STANDARD COMM.(RAINTIGHT)
(8)	MARINE FIRE MAIN STRAINER		STANDARD COMM.-300 PSI WOG
(9)	STRAINER		STANDARD COMM.-300 PSI WOG
(10)	PRESSURE GAUGE (0-300 PSIG)		STANDARD COMM.
(11)	FLOW PROPORTIONER	MIL-P-24589	FEECON PART 00897750
(12)	FOAM NOZZLE SINGLE AGENT 95GPM.	MIL-N-24480 TYPE1	AKRON BRASS STYLE 3019
(13)	HOSE REEL SINGLE AGENT	MIL-R-24414	AERO-MOTIVE MFG CO. MODEL NL20M
(14)	HOSE SOFT HARD RUBBER	MIL-H-24580	STANDARD COMM.
(15)	AFFF CONCENTRATE TANK		SEE NOTE 3 & 6
(16)	SIGHT GLASS W/GLASS GUARD		STANDARD COMM.-300 PSI WOG
(17)	MOTOR CONTROLLER		CONTRACTOR FIELD FABRICATED
(18)	BACKFLOW PREVENTER		STANDARD COMM.

SYMBOL	DESCRIPTION
F	175 PSIG WATER MAIN
H	HYDRAULIC CONTROL SYSTEM
AFFF	AFFF CONCENTRATE
AFFF-6	6% FOAM-WATER SOLUTION
	GATE VALVE W/LOCKING PIN
	STRAINER
	PET COCK.
	POWER/CONTROL WIRING
	REMOTE CONTROL VALVE HYDRAULIC OPER. DIAPHRAM TYPE. CONTROL LINE PRESS. TO CLOSE. WITH (NYCECK CONF.)
	PRESSURE GAUGE W/GAUGE COCK
	MARINE FIRE MAIN STRAINER
	GLOBE VALVE

NOT TO SCALE

Figure A-21B
AFFF Station

NOTES:

1. LOCATE SAMPLE COCK SO IT CAN FILL A 5 GALLON AFFF CAN.
2. ALL PIPES SHALL BE PIPED TO ALLOW DRAINING FOR FREEZE PROTECTION. PROVIDE DRAINS AT LOW POINTS.
3. TANK SIZE: 19F1A-80 GALLON
 19F3-B1-80 GALLON
 19F3-B3-100 GALLON
 19F3-B4-100 GALLON
 19F3A -100 GALLON
 19F5 -100 GALLON
4. SOURCE OF SUPPLY IS THE REQUIRED SOURCE OF SUPPLY.
5. PAINT WATER PIPING RED AFFF CONCENTRATE PIPING GREEN, 6% AFFF PIPING RED & GREEN STRIPED, EXCEPT AT FOAM STATION WHERE ONLY THE VALVE HANDLES SHALL BE COLOR CODED.
6. THE TANK SHALL HAVE:
 - (A) AN EXTERNALLY MOUNTED LIQUID LEVEL INDICATOR ASSEMBLY PROTECTED FROM BREAKAGE BY AN EXPANDED METAL CASE.
 - (B) A GOOSENECK PIPE VENT 1 INCH IN DIAMETER.
 - (C) TWO 8 INCH INSIDE DIAMETER TANK FILL FUNNEL TAPERING TO 3 INCH DIAMETER WITH A FLANGED TOP RIM BOLTED INTO A 3 INCH TALL BOSS ON THE TANK TOP. PROVIDE 3 INCH STAINLESS STEEL PIPE SCREENS, RUN PIPING TO 3 INCHES ABOVE TANK BOTTOM.
 - (D) A FUNNEL TOP THREADED TO RECEIVE A SCREW-IN FUNNEL COVER REQUIRING NO MORE THAN THREE TURNS TO REMOVE/REPLACE.
 - (E) A FUNNEL COVER FITTED WITH 4 INCH WIDE U-SHAPED HANDLE TO FACILITATE USE.
 - (F) A 3 INCH PIPE EXTENDING FROM THE FUNNEL BOTTOM TO WITHIN 2 INCHES OF THE TANK BOTTOM.
 - (G) A PUMP SUCTION CONNECTION WITH A WELDING REDUCER HAVING ITS LARGER END WELDED FLUSH WITH THE BOTTOM OF THE TANK. THE INLET AREA HAVING

Figure A-21C
AFFF Station

MIL-HDBK-1027/1

NOTES

APPROXIMATELY FOUR TIMES THE FLOW AREA OF THE SUCTION PIPING.

(H) TANK SHALL BE CONSTRUCTED OF STAINLESS STEEL (SS 316).

(I) A BOLTED ACCESS PLATE WITH GASKET IN THE TANK SIDE TO ALLOW A MINIMUM OF 12 INCHES CLEARANCE FOR CLEANING.

7. TRAINER REQUIREMENTS:

19F1A HAS 1 FOAM STATION SERVING 2 FOAM REELS

19F3-B1 HAS 1 FOAM STATION SERVING 2 FOAM REELS

19F3-B3 HAS 1 FOAM STATION SERVING 1 FOAM REEL

19F3-B4 HAS 1 FOAM STATION SERVING 1 FOAM REEL

19F3A HAS 1 FOAM STATION SERVING 3 FOAM REELS (USE OF STD. COMM. FOAM PROPORTIONING EQUIPMENT WITH 4 FOAM REELS IS APPROVED).

8. MOTOR CONTROLLER: (NEMA 4 ENCLOSURE)

(A) SEE SHEET 4 FOR PHYSICAL REQUIREMENTS

(B) SWITCHES SHALL BE APPROVED FOR WET LOCATIONS

9. MASTER SOPV

(A) USE 480V SOLENOIDS

10. AFFF PIPING, VALVES AND FITTINGS SHALL BE STAINLESS STEEL OR COPPER

11. PUMP IS BLACKMER PUMP MODEL BXL-1-1/4 (MFG. DWG NO. E-4638) WITH STD. ELECTRIC MOTOR (7-1/2 HP, TOTAL ENCLOSED FAN COOLED).

Figure A-21D
AFFF Station

MIL-HDBK-1027/1

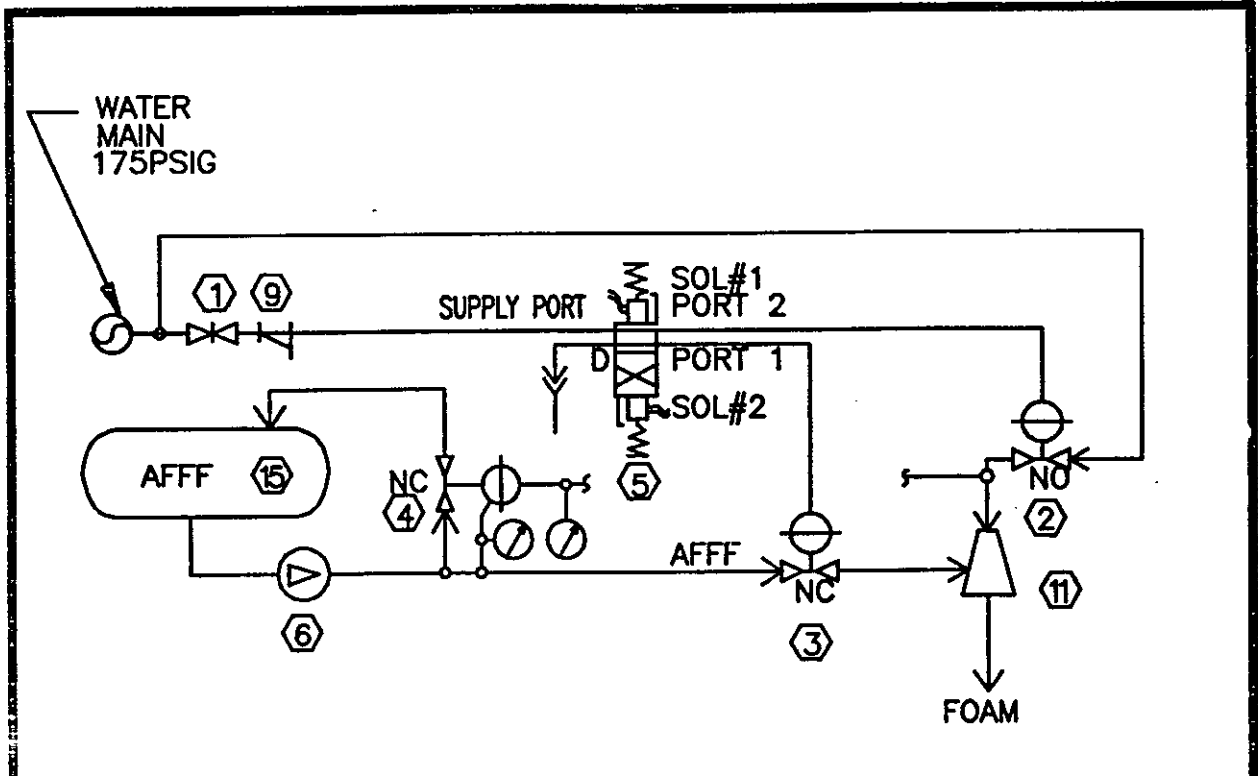

HYDRAULIC CONTROL DIAGRAM

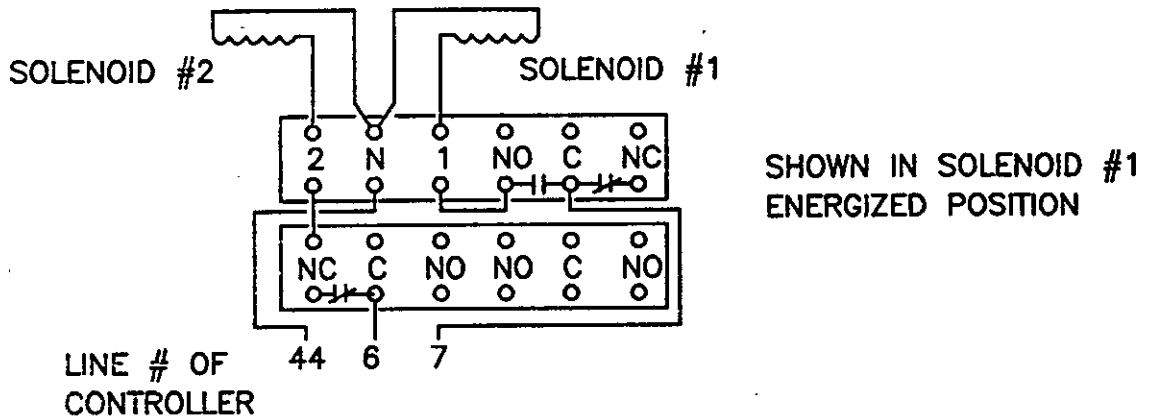

MASTER SOPV WIRING DIAGRAM 5
480V POWER

NOT TO SCALE

Figure A-21F
AFFF Station

MIL-HDBK-1027/1

SEQUENCE OF OPERATION

1. SUPPLY POWER TO MOTOR CONTROLLER CONTROL TRANSFORMER. THE WHITE POWER AVAILABLE LIGHT (IL 1) IS LIT. BOTH SELECTOR SWITCH ONE (SEL 1) AND SELECTOR SWITCH TWO (SEL 2) ARE IN "NORMAL" POSITION AND BOTH AFFF CONCENTRATE AND BACK PRESSURE GAGES SHOW NO PRESSURE.
2. IN NORMAL MODE BOTH SEL 1 AND SEL 2 SHALL BE IN "NORMAL" POSITION, MASTER SOPV CONNECTS SUPPLY PORT TO PORT #2 WHICH SUPPLIES PRESSURE TO (2) WATER CONTROL VALVE (PRESSURE TO CLOSE) AND CONNECTS DRAIN PORT TO PORT #1 WHICH RELIEVES PRESSURE TO (3) AFFF CONCENTRATE DISCHARGE CONTROL VALVE (RELIEF TO CLOSE). (4) BACK PRESSURE REGULATING VALVE IS IN FULL RECIRCULATING MODE TO AFFF TANK.
3. TO START PUMP
 - A. LOCAL OPERATING MODE: PLACE "NORMAL/LOCAL RUN" SWITCH (SEL 1) IN THE LOCAL RUN POSITION THE PUMP WILL START AND GREEN MOTOR RUN LIGHT (IL 2) ON THE CONTROLLER IS LIT.
 - B. REMOTE OPERATING MODE ((7) HOSE STATION PUSHBUTTON): MOMENTARILY PUSH HOSE REEL PUSHBUTTON. THE PUMP WILL START AND GREEN MOTOR RUN LIGHT (IL 2) ON THE CONTROLLER IS LIT. IN ORDER TO ENERGIZE SOLENOID #2, MOMENTARILY PRESS THE PUSHBUTTON. THE PURPOSE OF THE LOCAL MODE IS TO ALLOW THE AFFF PUMPS TO RUN, READY FOR ACTION, WITHOUT INJECTING FOAM INTO THE WATER MAIN. WHEN THE FOAM REEL STATIONS ARE READY FOR FOAM, THE TRAINEE PRESSES THE REMOTE PUSHBUTTON.
4. WHEN PUMP IS RUNNING, THE MOTOR CONTROLLER ENERGIZES SOLENOID #2 OF OF THE (5) MASTER SOPV, WHICH CONNECTS SUPPLY PORT TO PORT #1 WHICH SUPPLIES PRESSURE TO (3) AFFF CONCENTRATE CONTROL VALVE WHICH GOES TO FULL OPEN POSITION AND CONNECTS DRAIN PORT TO PORT #2 WHICH RELIEVES PRESSURE TO (2) WATER CONTROL VALVE WHICH GOES TO FULL OPEN POSITION. SOLENOID #2 IS DEENERGIZED AT THE END OF ITS STROKE.
5. THE (4) BACK PRESSURE REGULATING VALVE SHALL SELF REGULATE SO THAT THE PRESSURE OF THE AFFF CONCENTRATE IS EQUAL TO THE WATER AT THE FLOW PROPORTIONER.

Figure A-21G
AFFF Station

MIL-HDBK-1027/1

SEQUENCE OF OPERATION (CONTINUED):

6. TO STOP PUMP

A. LOCAL OPERATING MODE:

- (1) PLACE "NORMAL/LOCAL RUN" SWITCH (SEL 1) TO "NORMAL" POSITION.
- (2) MOMENTARILY PLACE "NORMAL/OFF" SWITCH (SEL 2) TO "OFF" POSITION. TO ENERGIZE SOLENOID #1 TO CLOSE (3) AFFF CONCENTRATE VALVE AND (2) WATER CONTROL VALVE, AND RESET LATCH RELAY.

B. REMOTE OPERATING MODE:

- (1) MOMENTARILY PLACE "NORMAL/OFF" SWITCH TO "OFF" POSITION TO ENERGIZE SOLENOID #1 TO CLOSE (3) AFFF CONCENTRATE VALVE AND
- (2) WATER CONTROL VALVE AND RESET LATCH RELAY.

Figure A-21H
AFFF Station

NOT TO SCALE

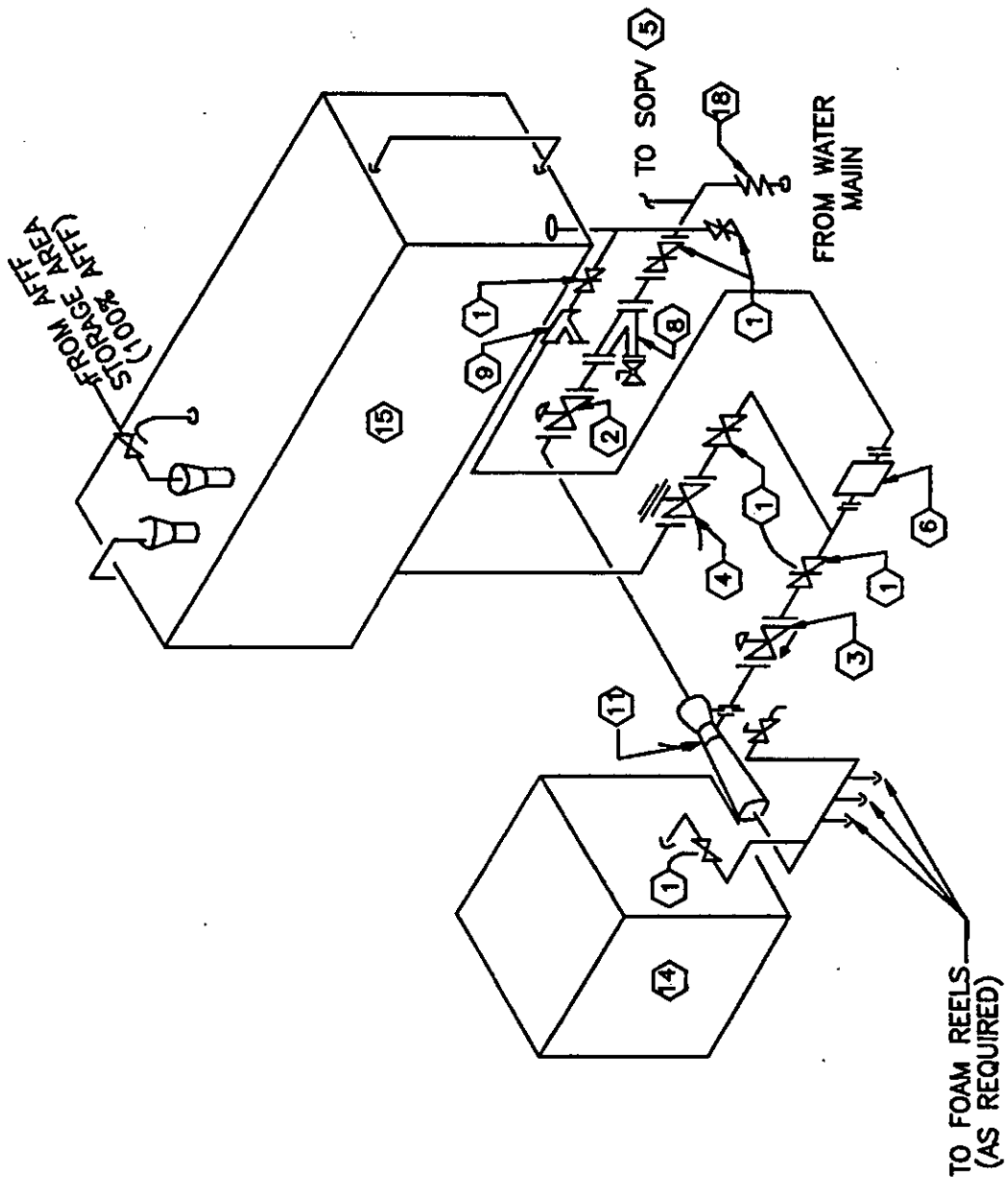

PIPING ISOMETRIC

Figure A-21I
AFFF Station

MIL-HDBK-1027/1

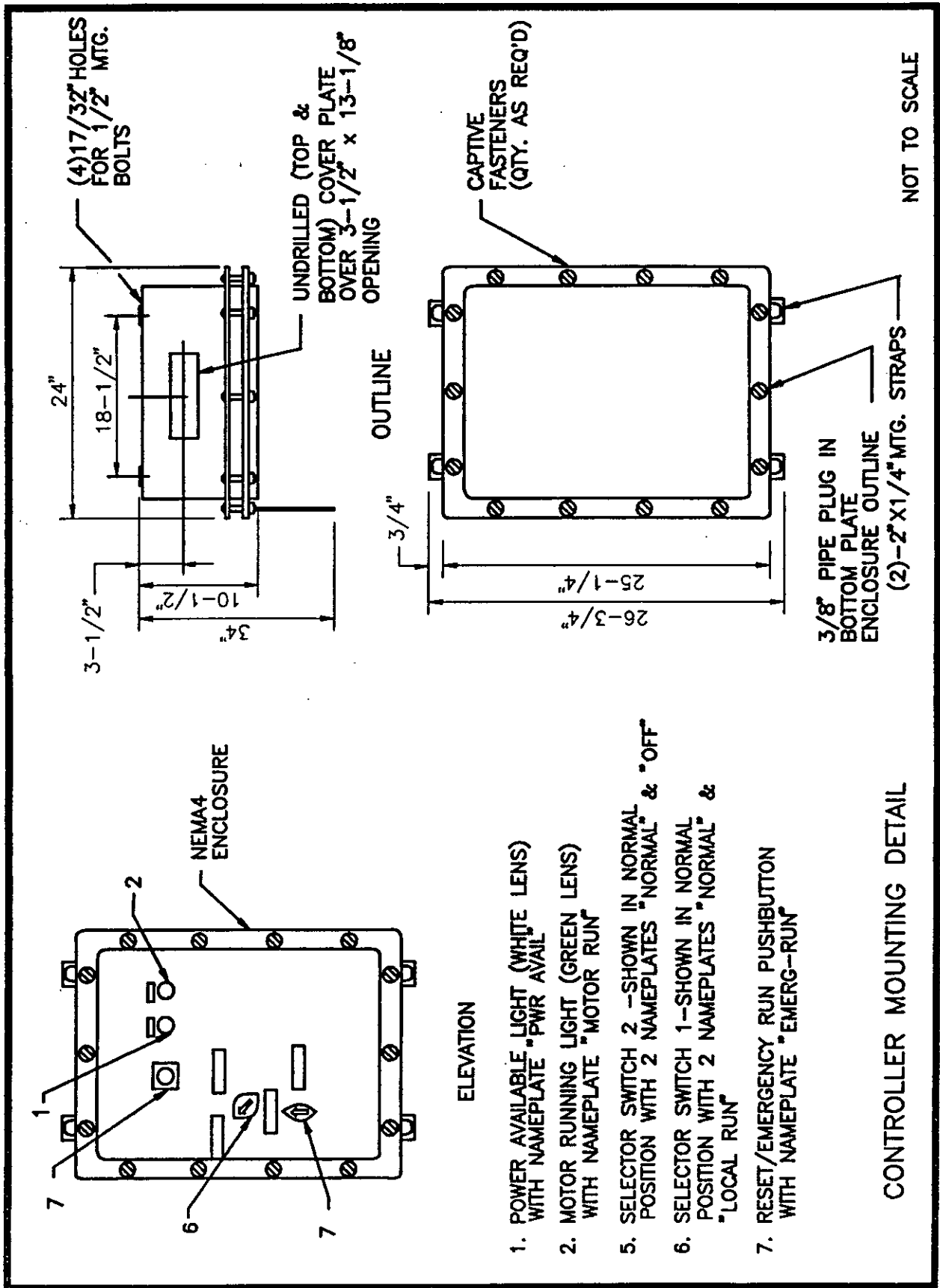

1. POWER AVAILABLE LIGHT (WHITE LENS) WITH NAMEPLATE "PWR AVAIL"
2. MOTOR RUNNING LIGHT (GREEN LENS) WITH NAMEPLATE "MOTOR RUN"
5. SELECTOR SWITCH 2 - SHOWN IN NORMAL POSITION WITH 2 NAMEPLATES "NORMAL" & "OFF"
6. SELECTOR SWITCH 1 - SHOWN IN NORMAL POSITION WITH 2 NAMEPLATES "NORMAL" & "LOCAL RUN"
7. RESET/EMERGENCY RUN PUSHBUTTON WITH NAMEPLATE "EMERG-RUN"

CONTROLLER MOUNTING DETAIL

Figure A-21J
AFF Station

MIL-HDBK-1027/1

LUMINAIRE REQUIREMENTS

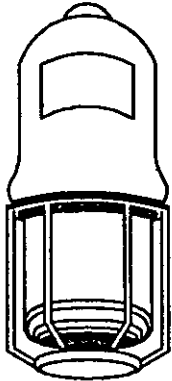

TYPE 1 & 2

1. LUMINAIRE SHALL MEET U.L. 844 OR FACTORY MUTUAL (FM) STANDARD FOR HAZARDOUS LOCATIONS.
2. LUMINAIRE SHALL MEET U.L. 595 FOR MARINE LOCATIONS.
3. HOUSING SHALL BE COPPER FREE CAST ALUMINUM WITH LACQUER OR EPOXY FINISH.
4. ALL JOINTS SHALL BE OF THE THREADED TYPE.
5. HEAT AND IMPACT RESISTANT PRESTRESSED GLASS GLOBE.
6. PROVIDE GLOBE GUARD INDICATED.
7. PROVIDE LAMPS AS INDICATED.
8. MOUNTING AS INDICATED.
9. PROVIDE INTERNAL GREEN GROUNDING SCREW.

TYPE 1 TWO 9 WATT COMPACT FLUORESCENT LUMINAIRES RATED FOR CLASS 1 DIVISION 2 GROUP D ATMOSPHERE.

TYPE 2 70-250WATT HPS OR 175-400 WATT MET. HALIDE LUMINAIRE RATED FOR CLASS 1 DIVISION 2 GROUP D ATMOSPHERE.

Figure A-22
Luminaire, Type 1 & 2

MIL-HDBK-1027/1

APPENDIX B
19F1A AND 19F1B STRUCTURES

19F1A/19F1B	Isometric	B-1
19F1A/19F1B	Staging Area Plan	B-2
19F1A/19F1B	Second Floor Plan	B-3
19F1A/19F1B	First Floor Plan	B-4
19F1A/19F1B	Sections	B-5

MIL-HDBK-1027/1

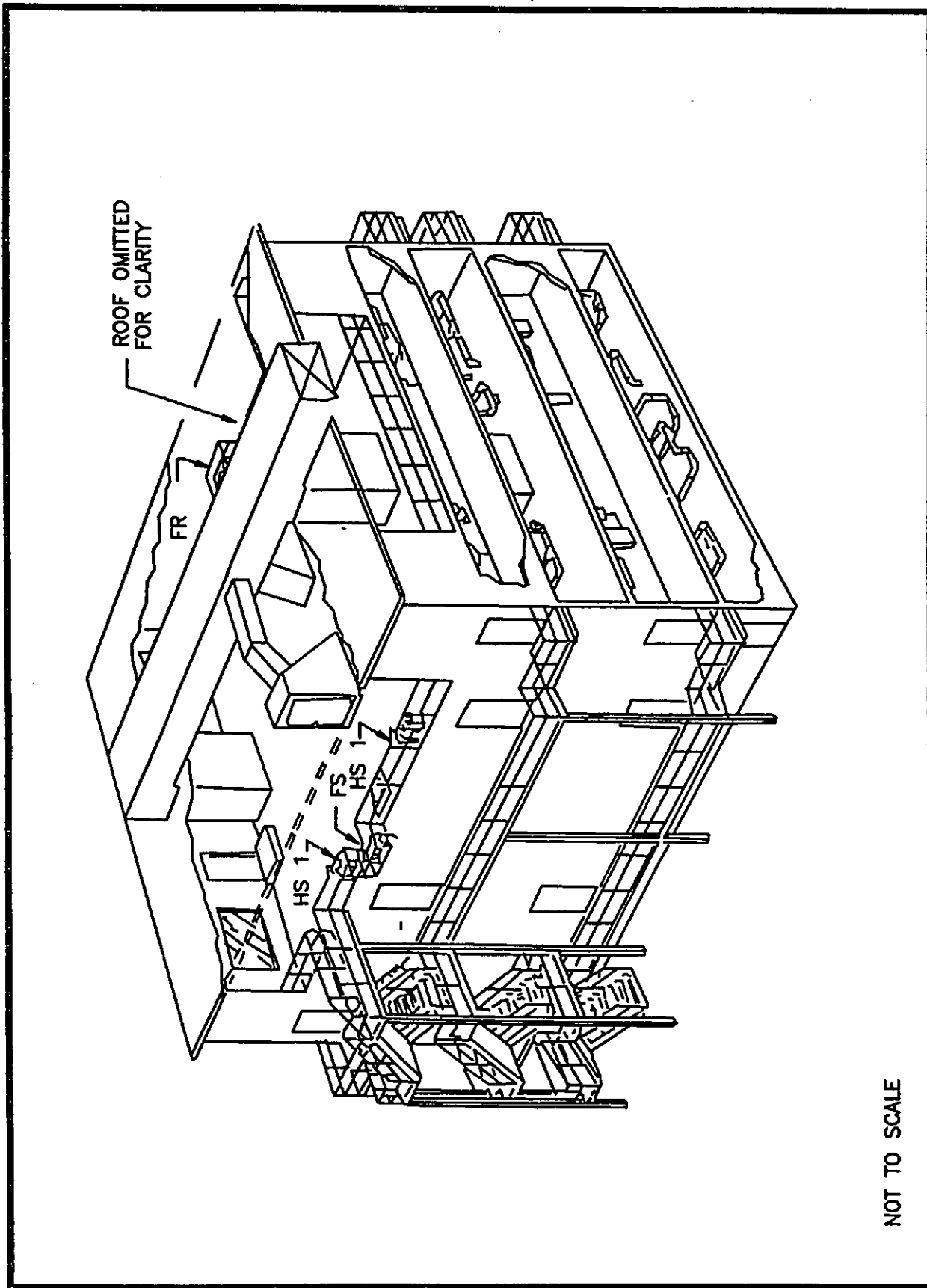

Figure B-1
19F1A/19F1B Isometric

MIL-HDBK-1027/1

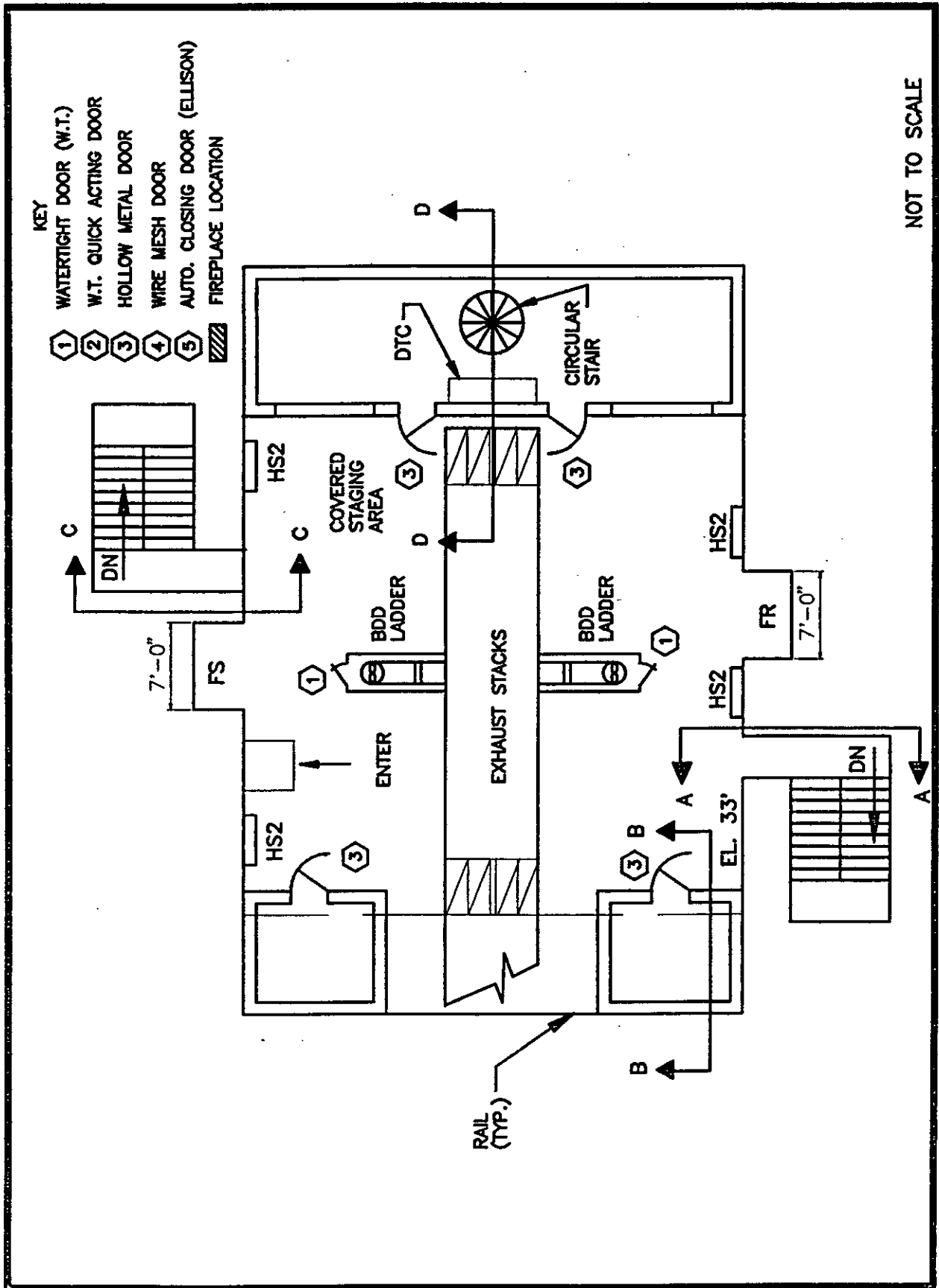

Figure B-2
19F1A/19F1B Staging Area Plan

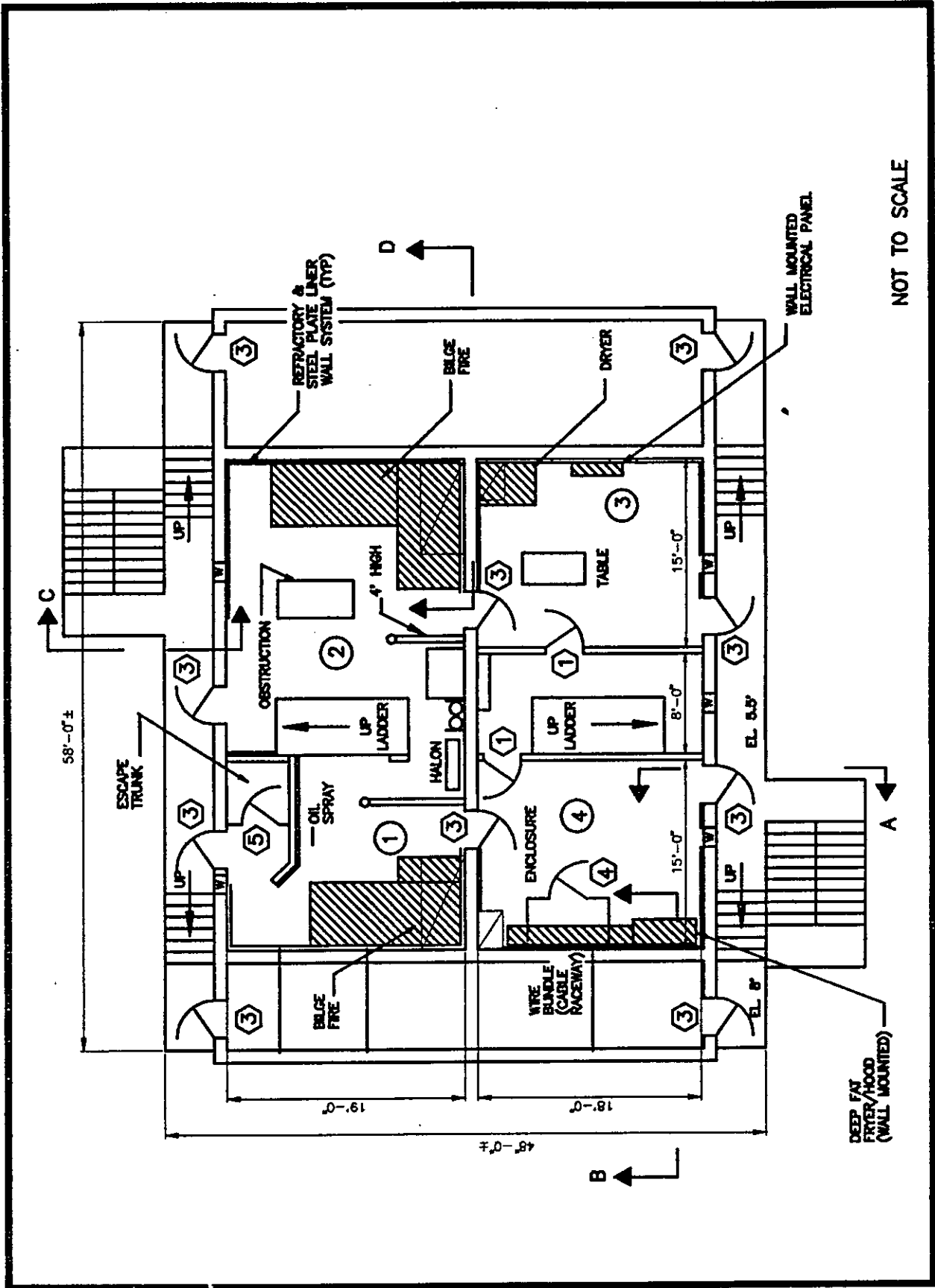

Figure B-4
19F1A/19F1B First Floor Plan

MIL-HDBK-1027/1

APPENDIX C
19F3 AND 19F3B STRUCTURES

19F3/19F3B	B1 Bilge Fire Building Roof Plan	C-1
19F3/19F3B	B1 First Floor Plan	C-2
19F3/19F3B	Galley/Berthing Building, B2, First Floor Plan	C-3
19F3/19F3B	Pit Fire Building, B3 & B4, First Floor Plan	C-4
19F3/19F3B	B1 Sections	C-5
19F3/19F3B	B2 Section	C-6
19F3/19F3B	B3/B4 Section	C-7

MIL-HDBK-1027/1

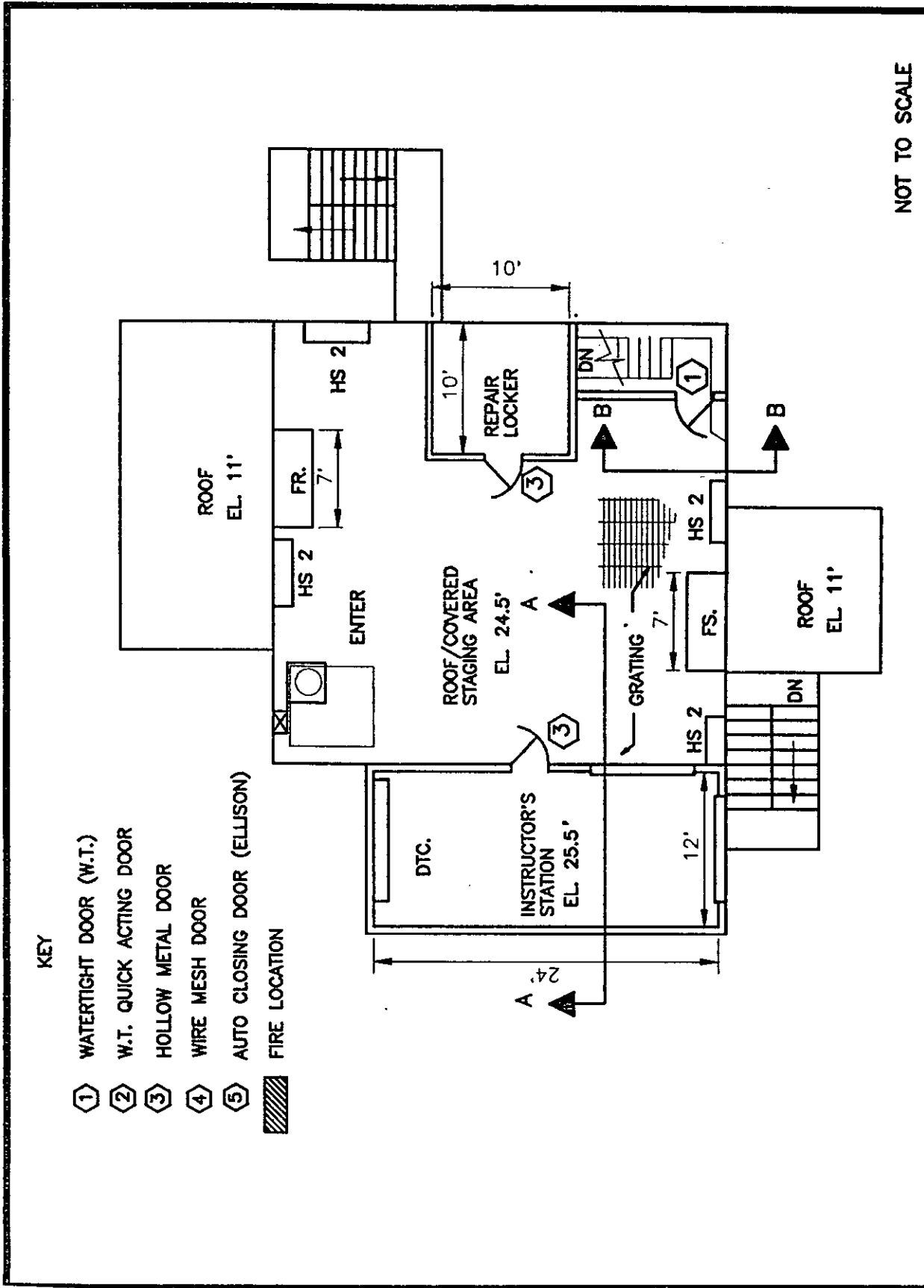

NOT TO SCALE

Figure C-1
19F3/19F3B B-1 Bilge Fire Building Roof Plan

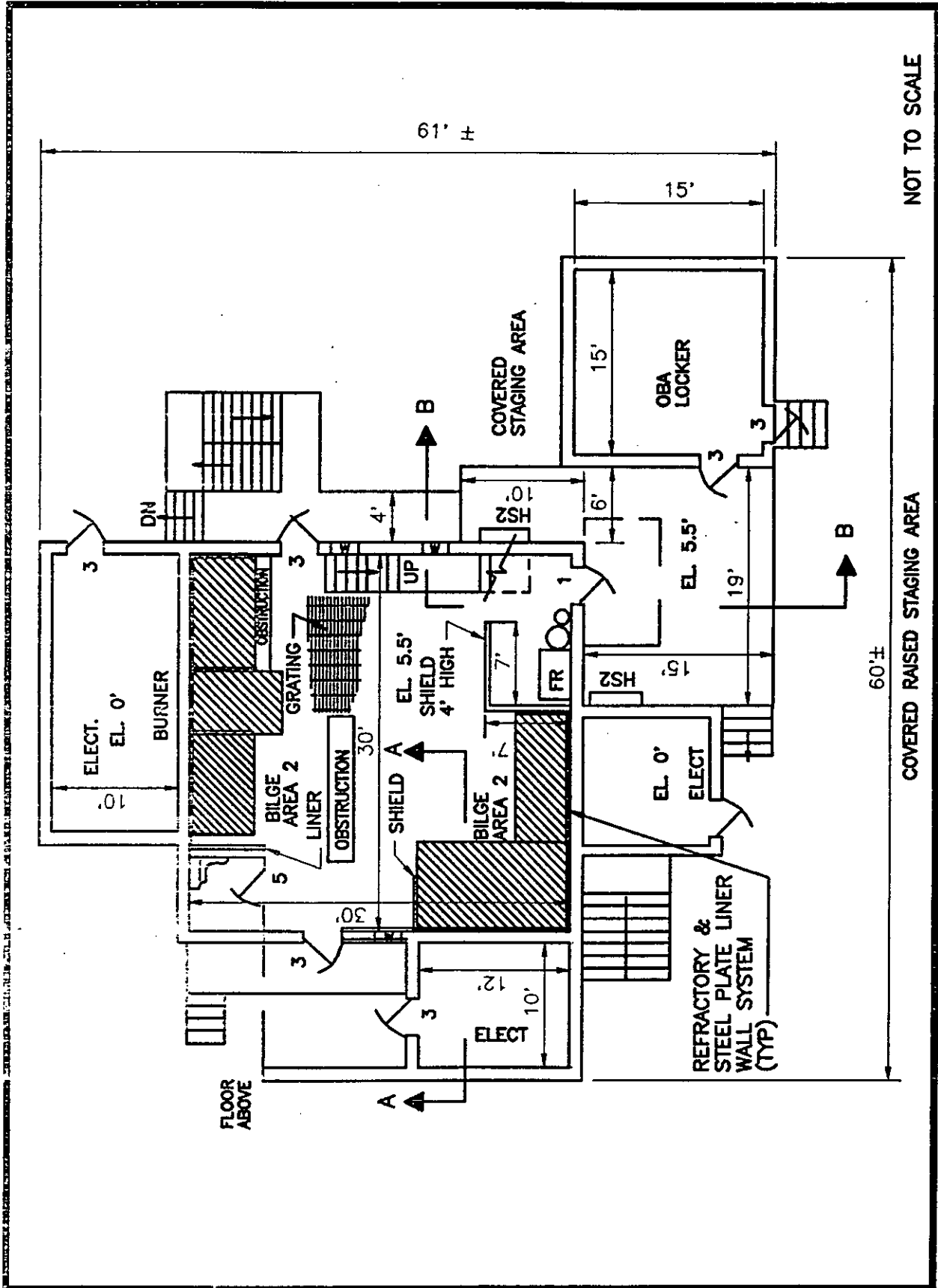

Figure C-2
19F3/19F3B B-1 First Floor Plan

MIL-HDBK-1027/1

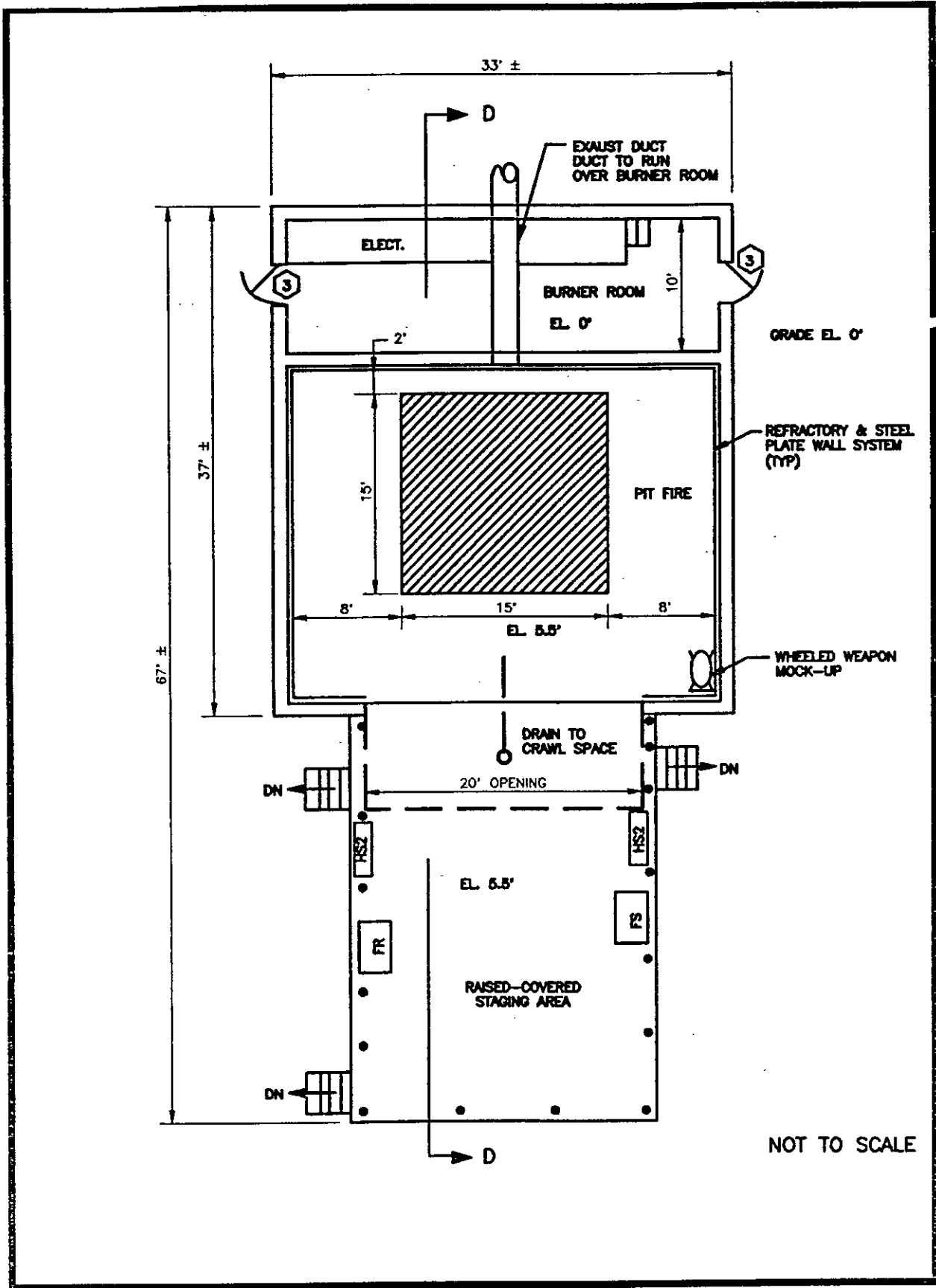

Figure C-4
19F3/19F3B Pit Fire Building B3 & B4 First Floor Plan

MIL-HDBK-1027/1

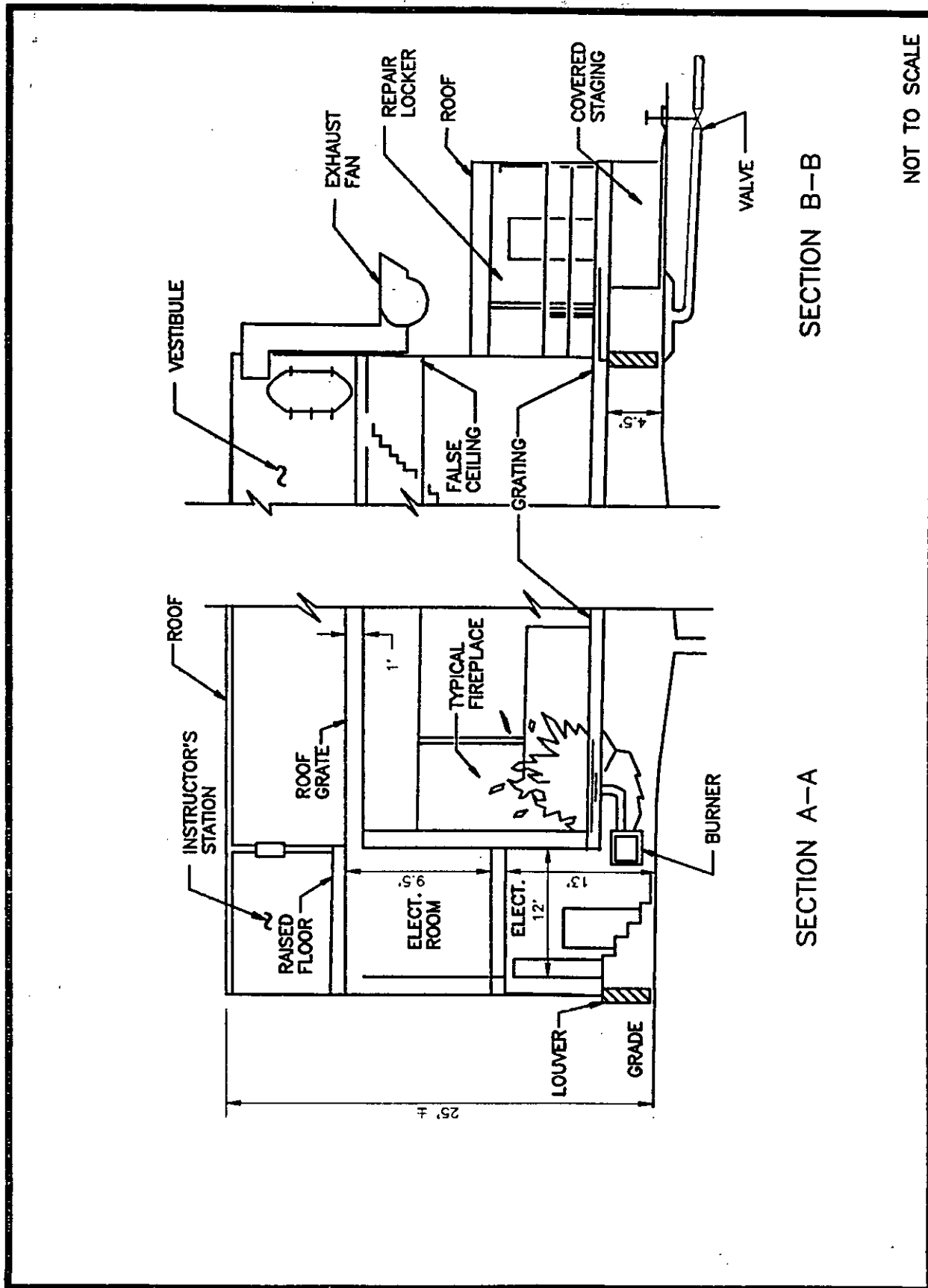

Figure C-5
19F3/19F3B B1 Sections

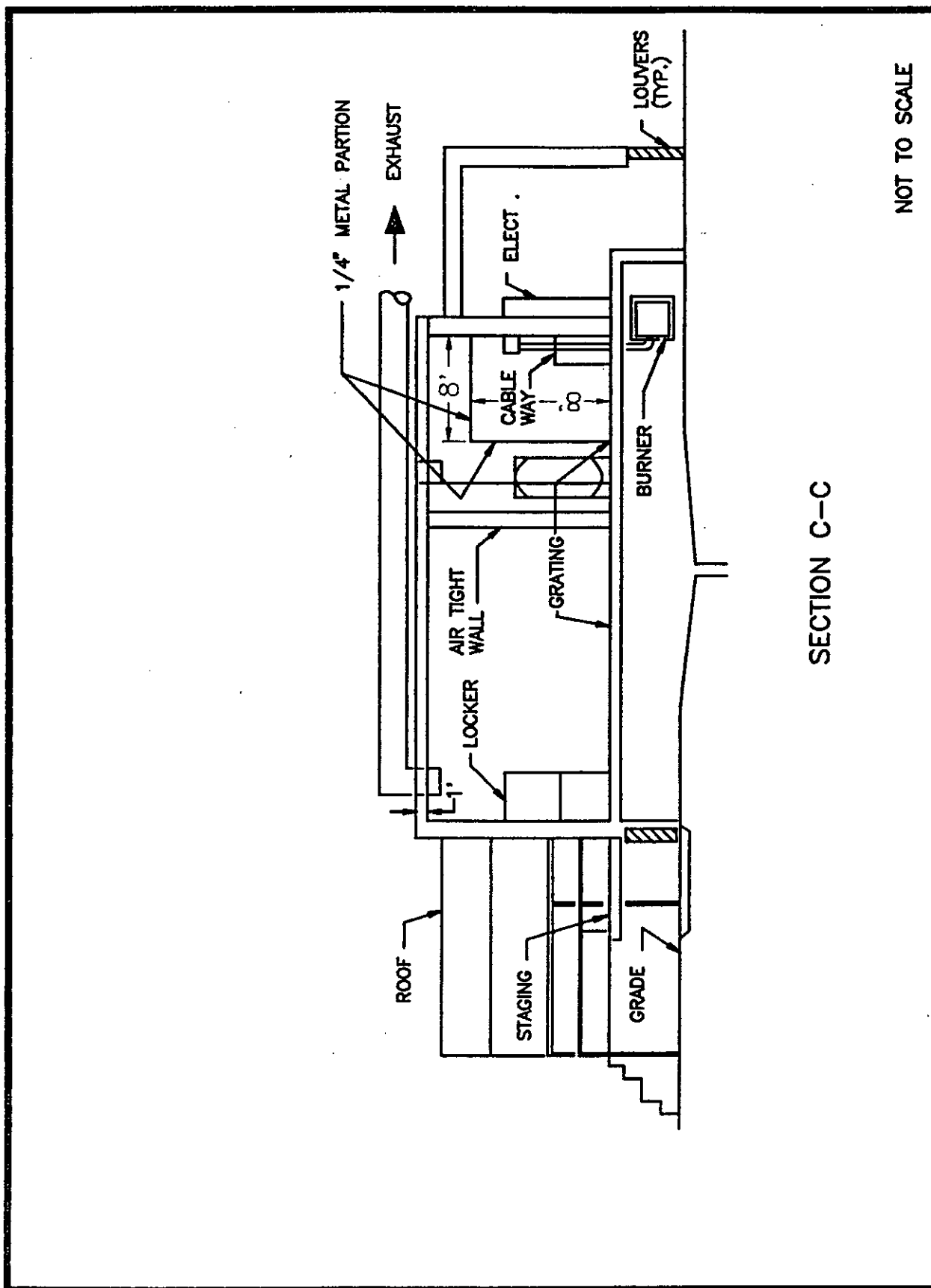

Figure C-6
19F3/19F3B B2 Section

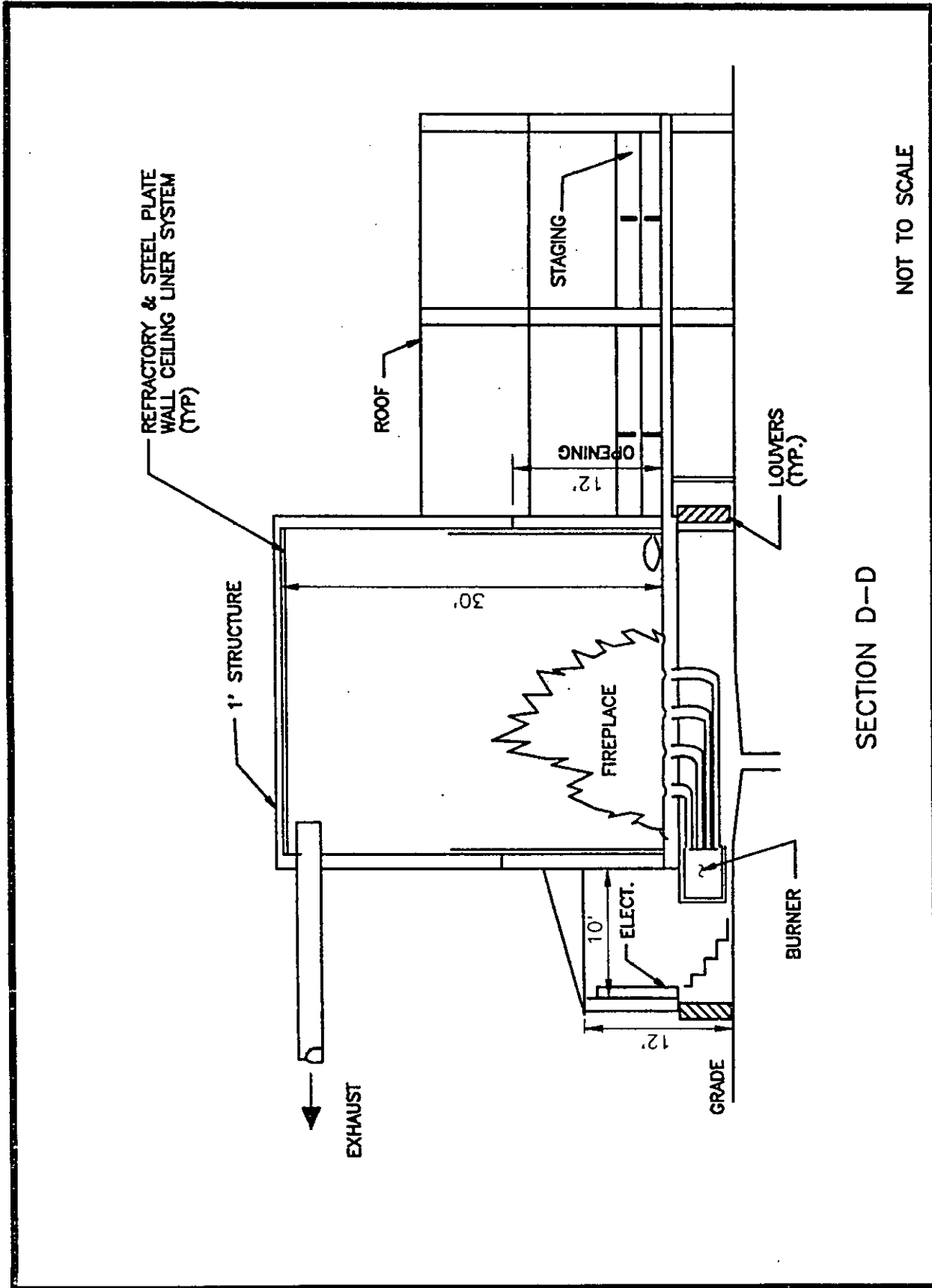

Figure C-7
19F3/19F3B B3/B4 Section

MIL-HDBK-1027/1

APPENDIX D
19F3A AND 19F3C STRUCTURES

19F3A/19F3C	First Floor Plan	D-1
19F3A/19F3C	Second Floor Plan	D-2
19F3A/19F3C	Roof Plan	D-3
19F3A/19F3C	Elevation	D-4

NOT TO SCALE

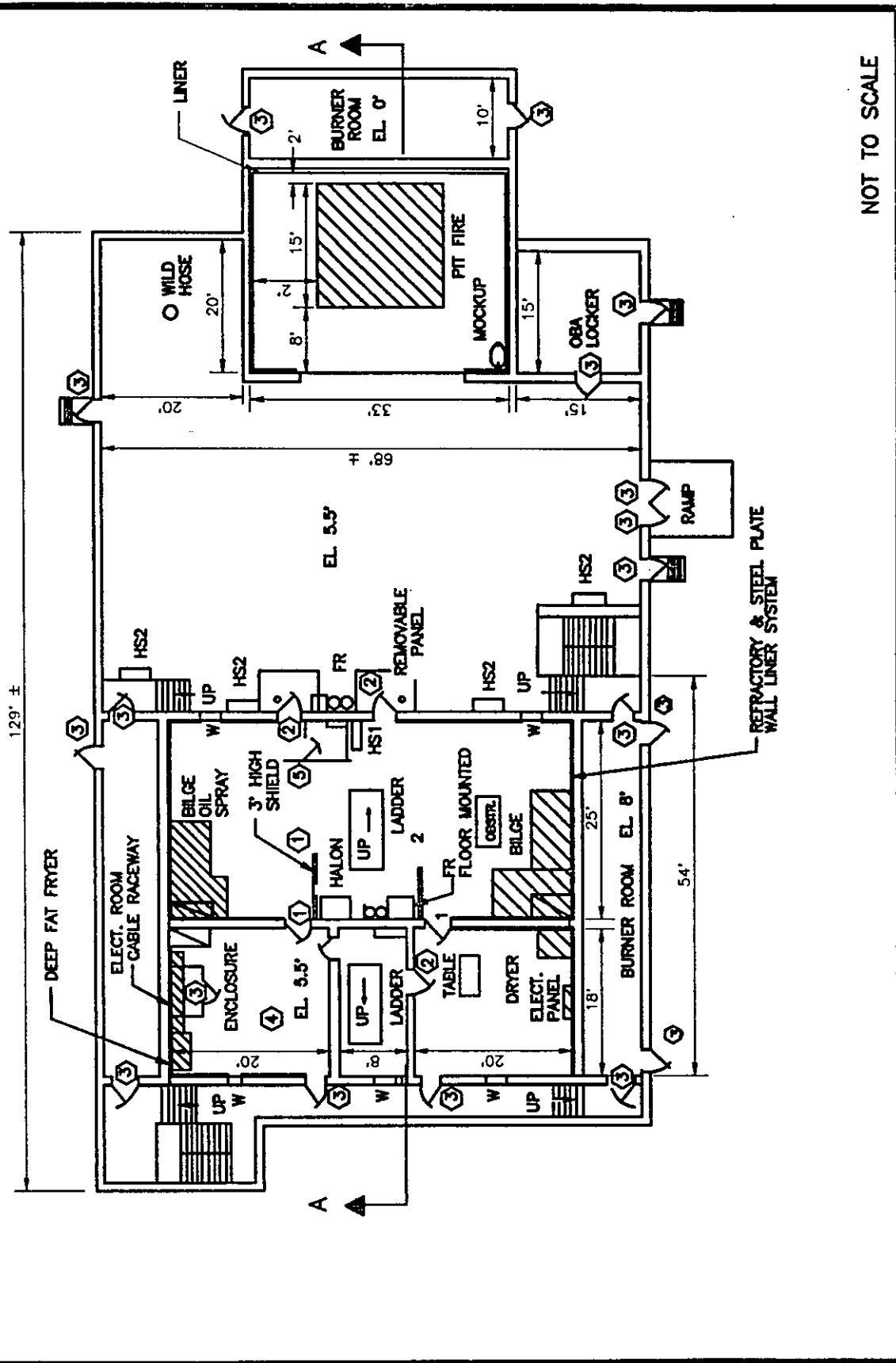
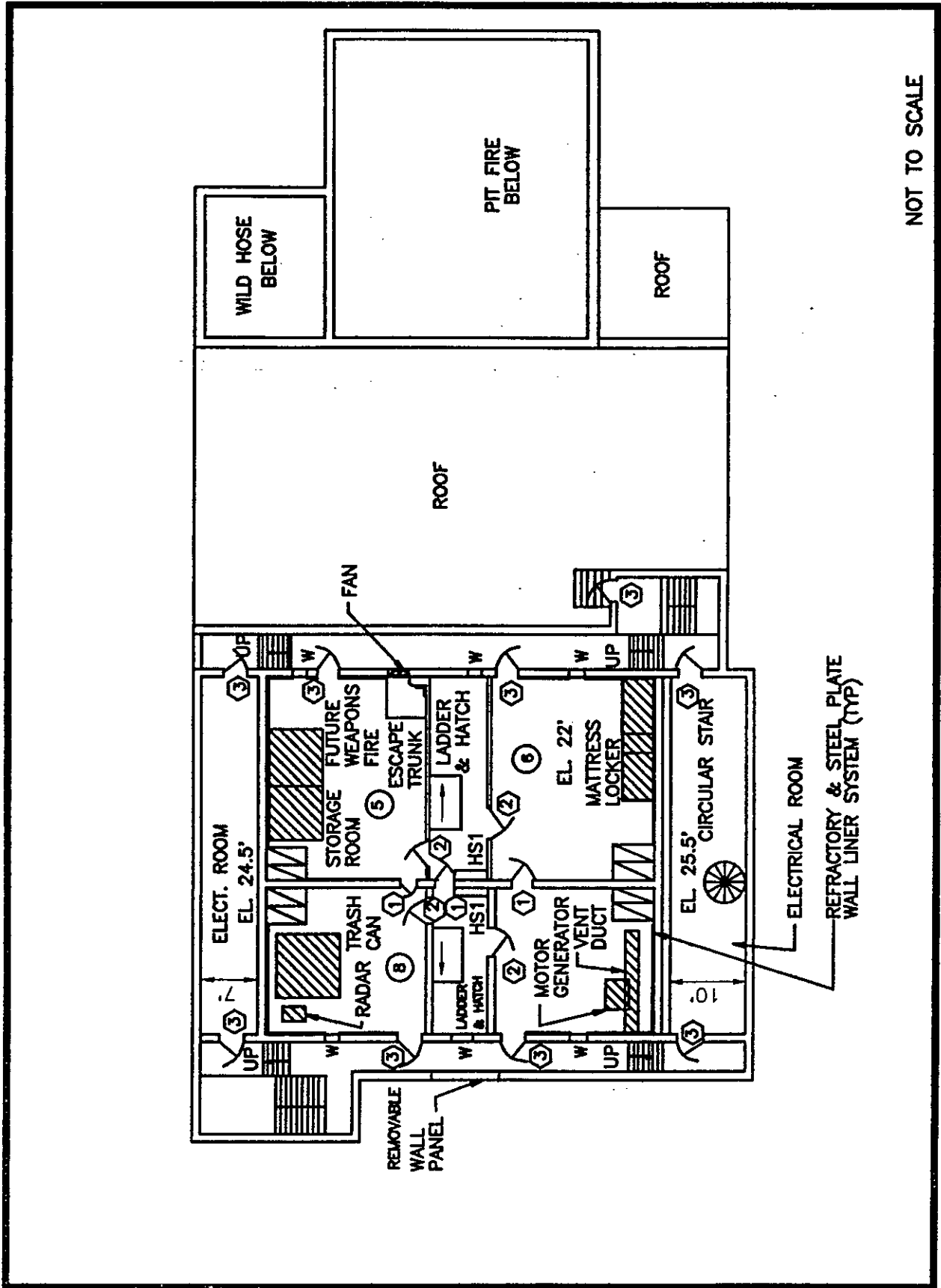

Figure D-1
19F3A/19F3C First Floor Plan



NOT TO SCALE

Figure D-2
19F3A/19F3C Second Floor Plan

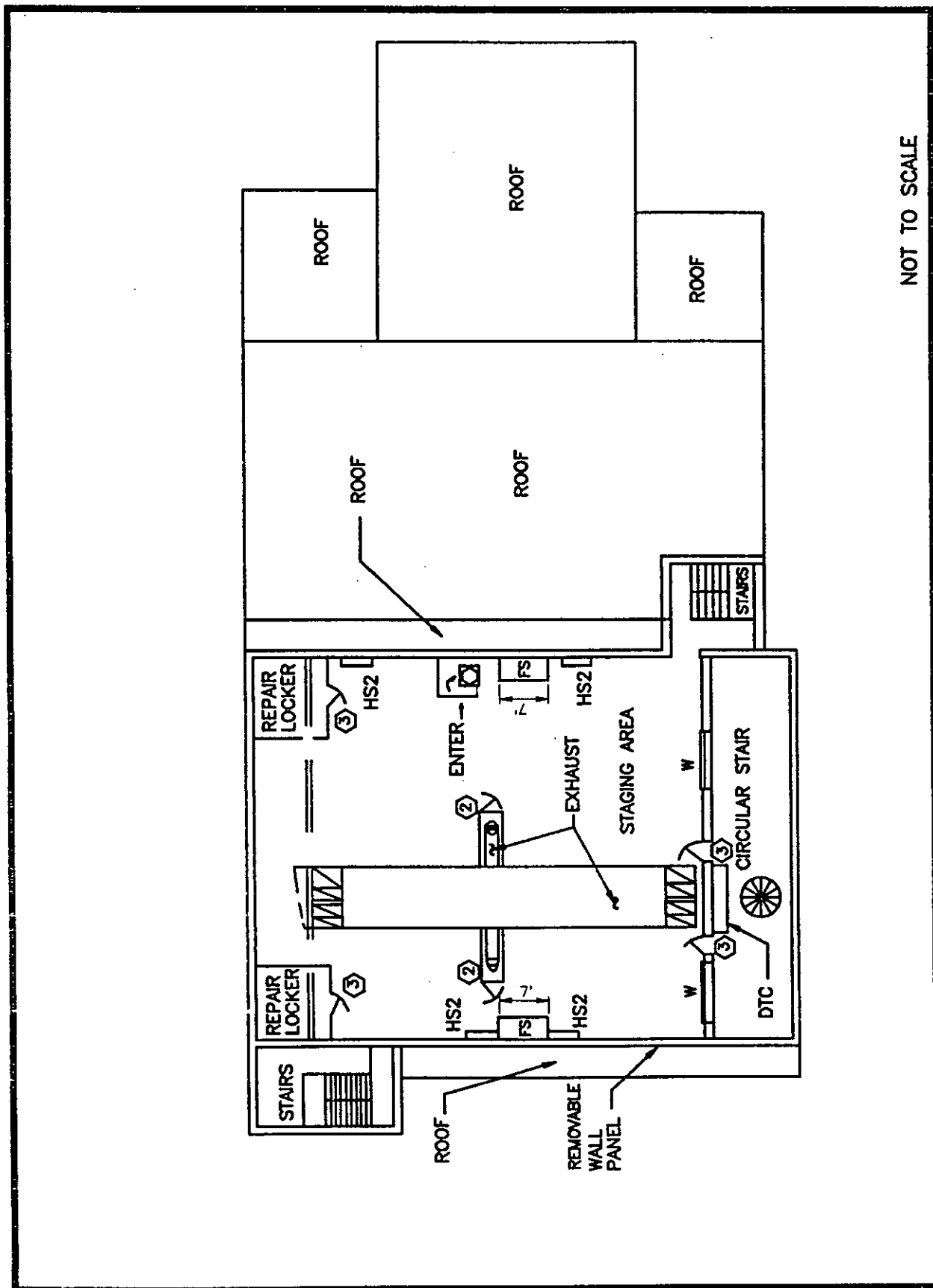
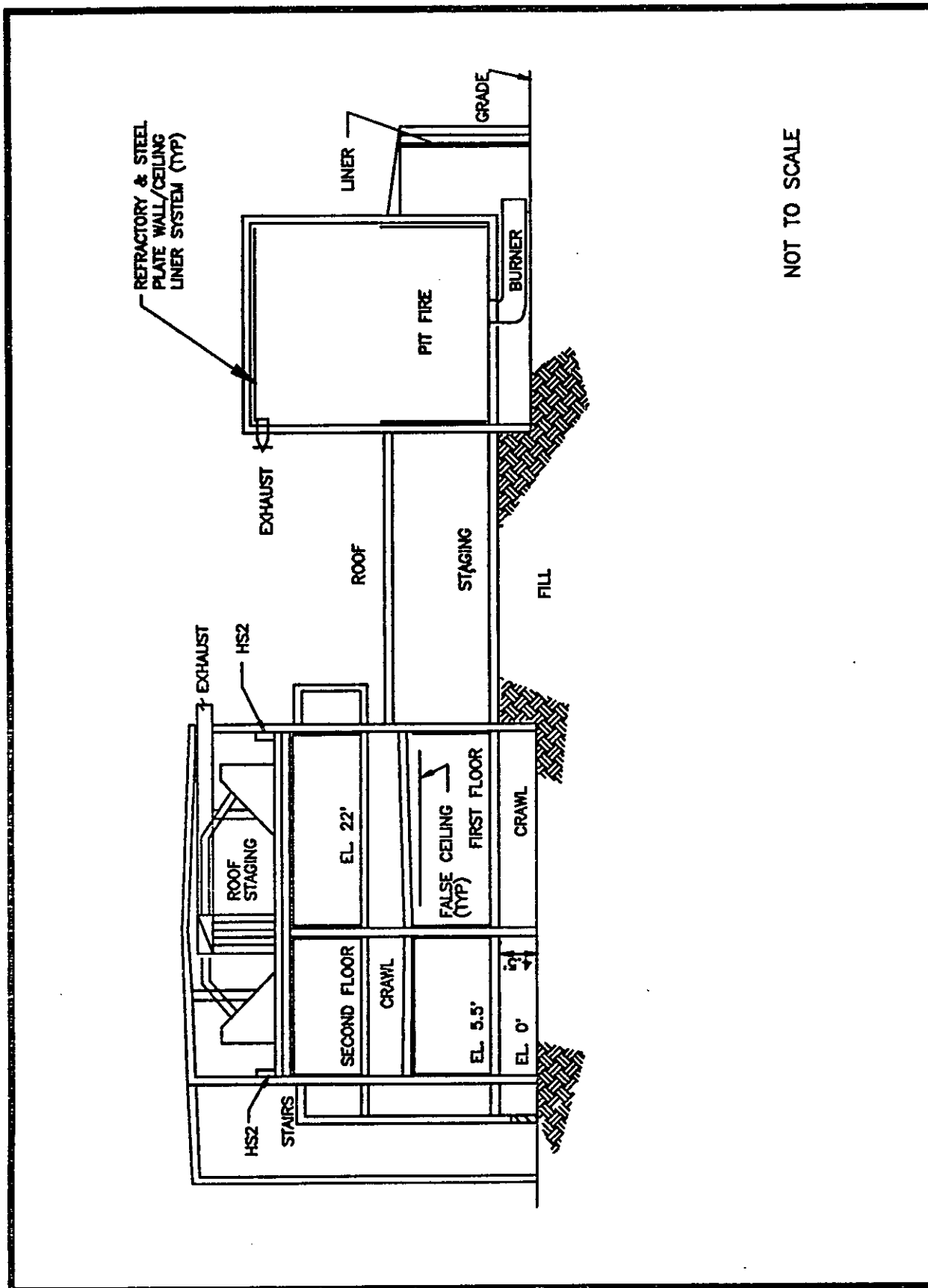

Figure D-3
19F3A/19F3C Roof Plan



NOT TO SCALE

Figure D-4
19F3A/19F3C Elevation

MIL-HDBK-1027/1

APPENDIX E
19F4 AND 19F4A STRUCTURES

19F4/19F4A	Training Deck Floor Plan	E-1
19F4/19F4A	Elevation	E-2
19F4/19F4A	Foam Deck	E-3
19F4/19F4A	Crane Detail	E-4
19F4/19F4A	Gantry Crane	E-5
19F4/19F4A	AFFF Balanced Pressure Proportioning System	E-6
19F4/19F4A	Training and Foam Deck Railing	E-7
19F4/19F4A	Crawl Space Plan and Pedestal	E-8

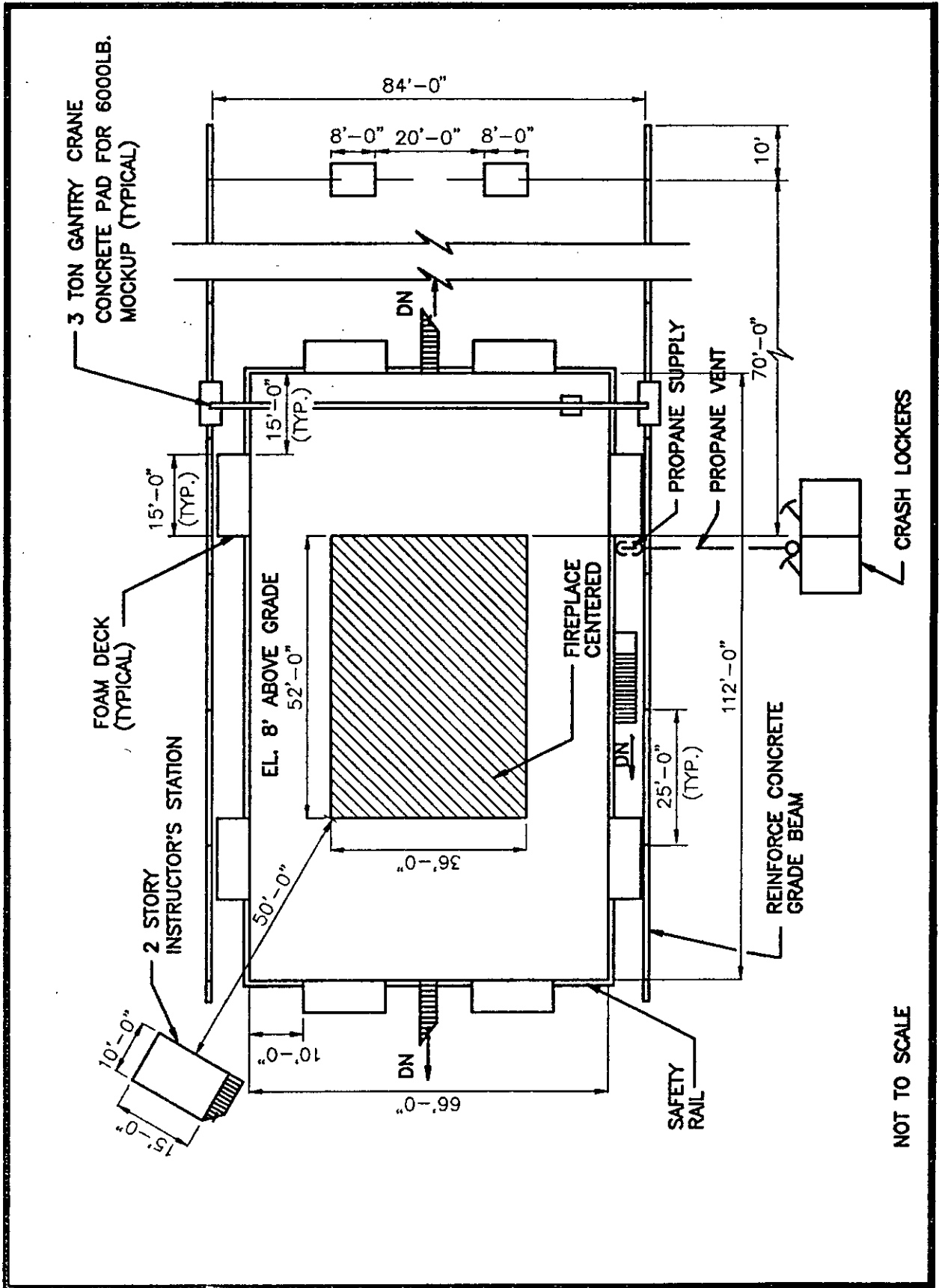

Figure E-1
19F4/19F4A Training Deck Floor Plan

MIL-HDBK-1027/1

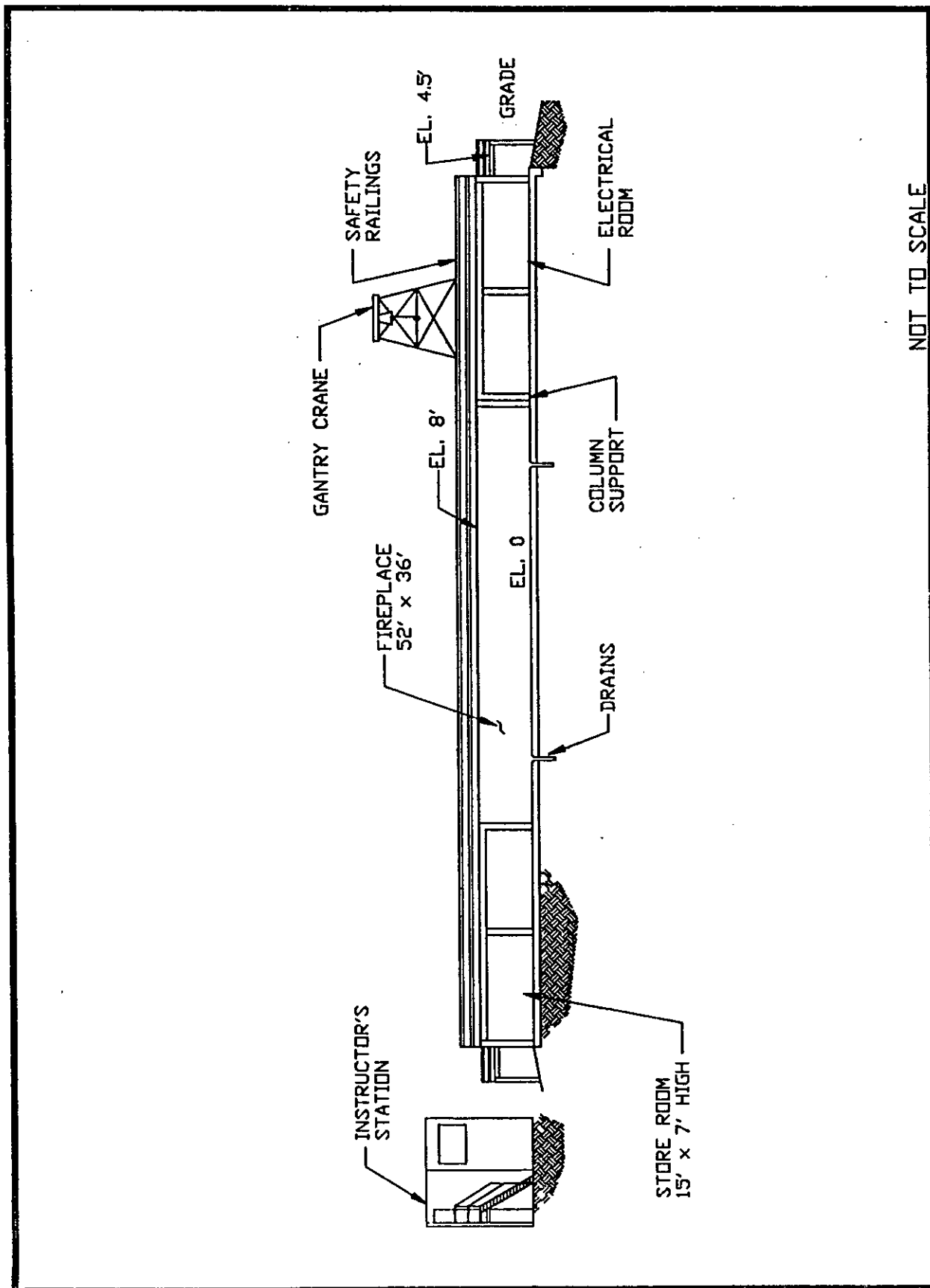
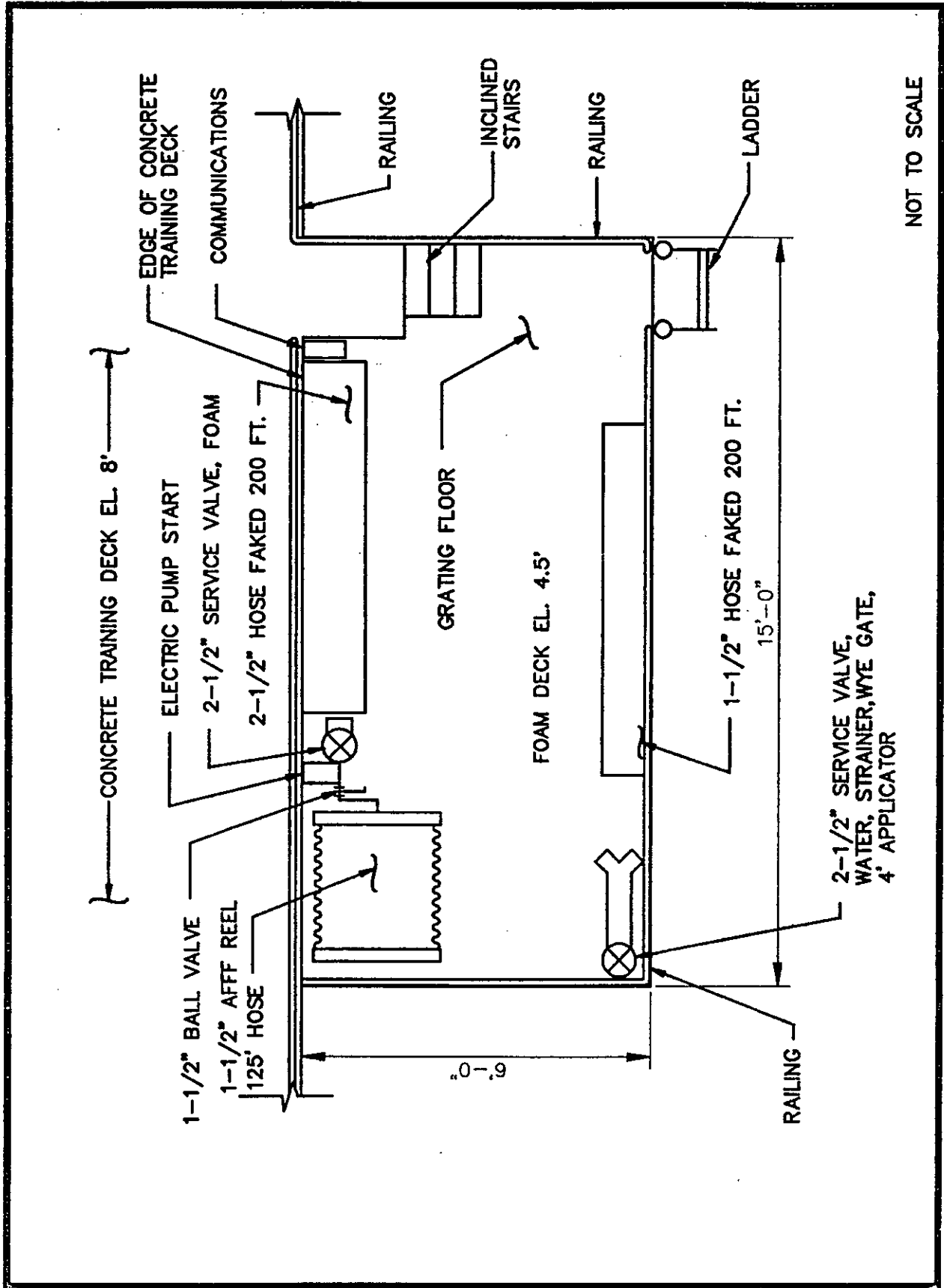

Figure E-2
19F4/19F4A Elevation



NOT TO SCALE

Figure E-3
19F4/19F4A Foam Deck

MIL-HDBK-1027/1

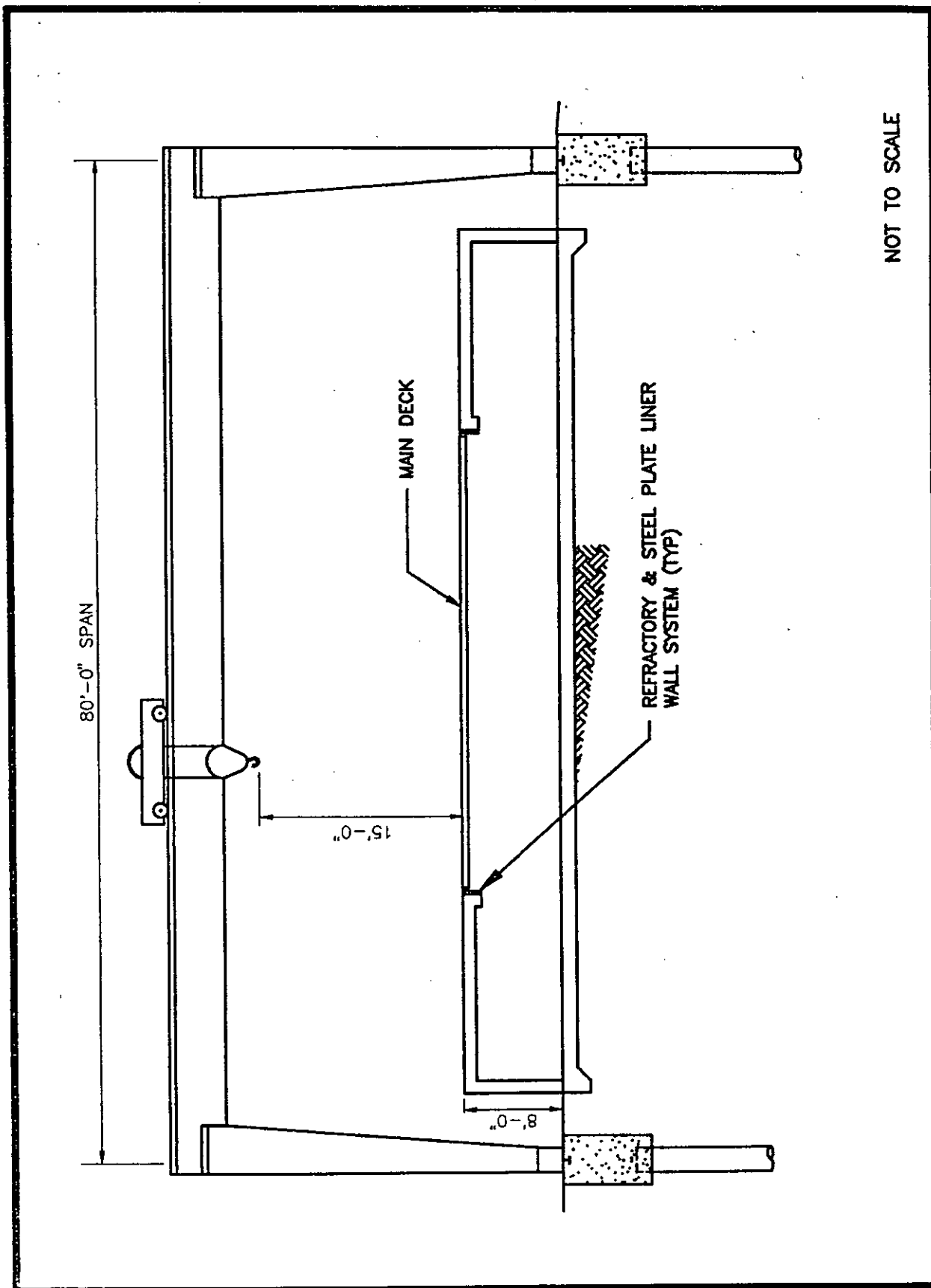

Figure E-4
Crane Detail

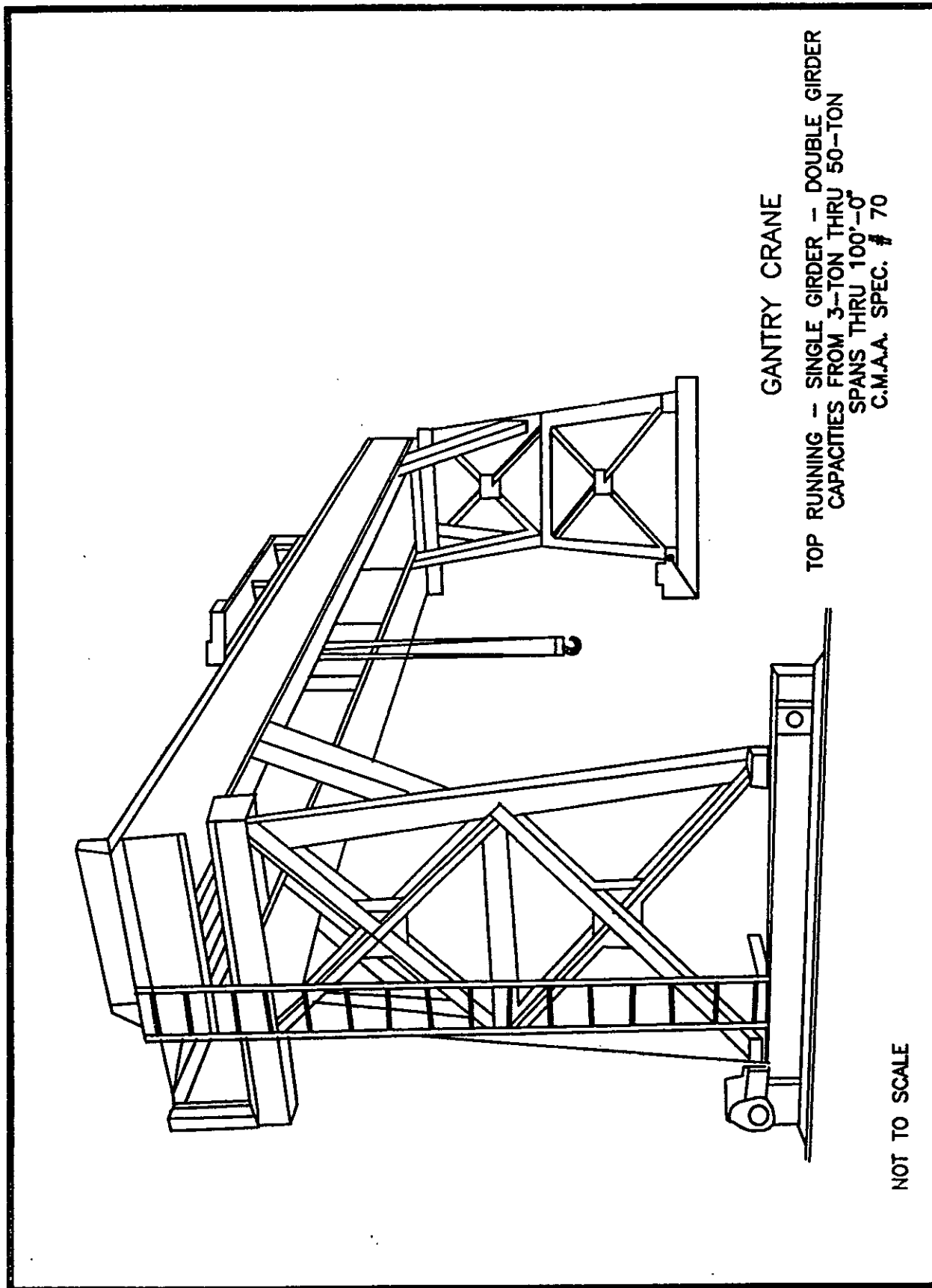

Figure E-5
Gantry Crane

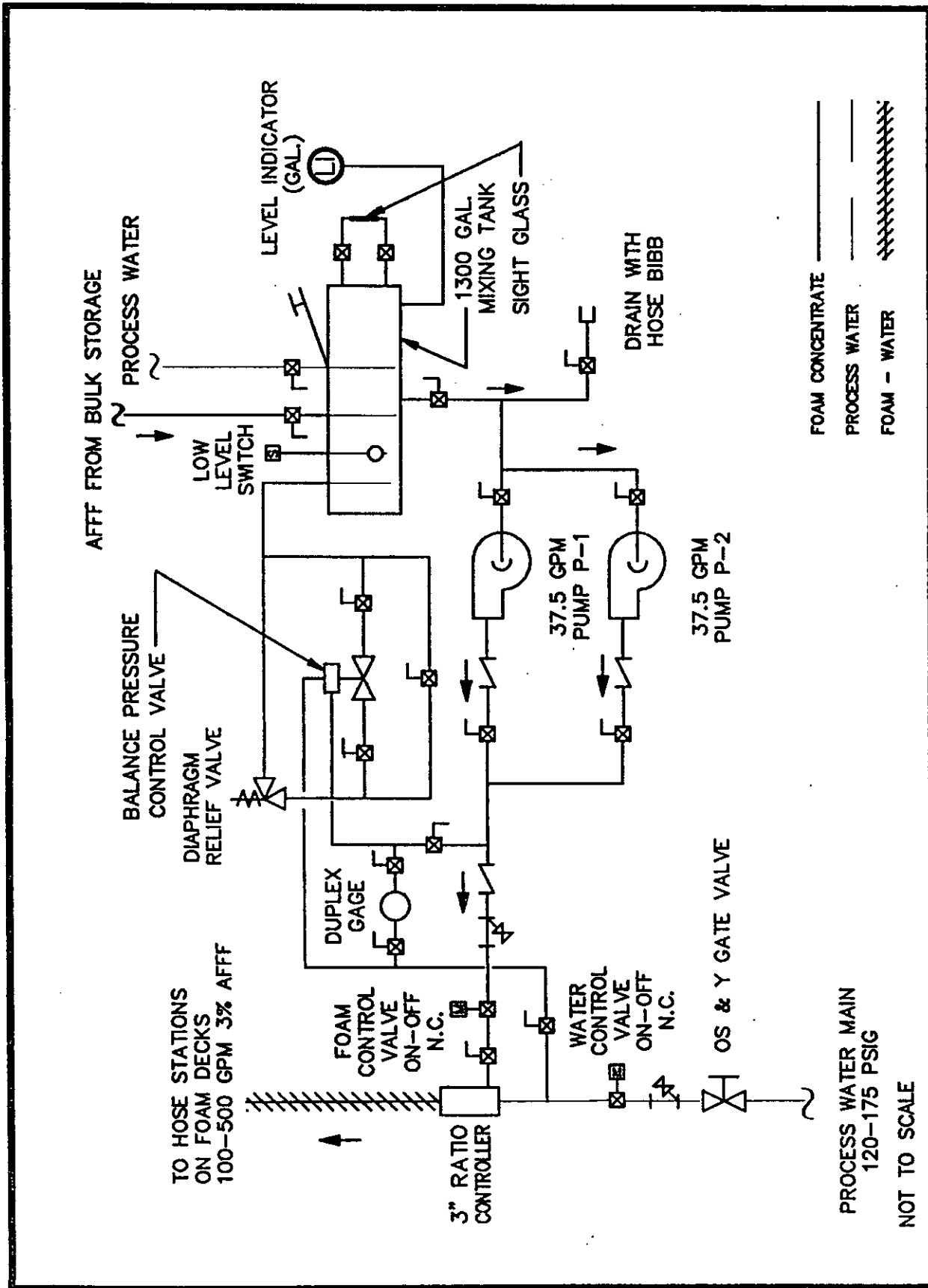

Figure E-6
19F4/19F4A AFFF Balanced Pressure Proportioning System

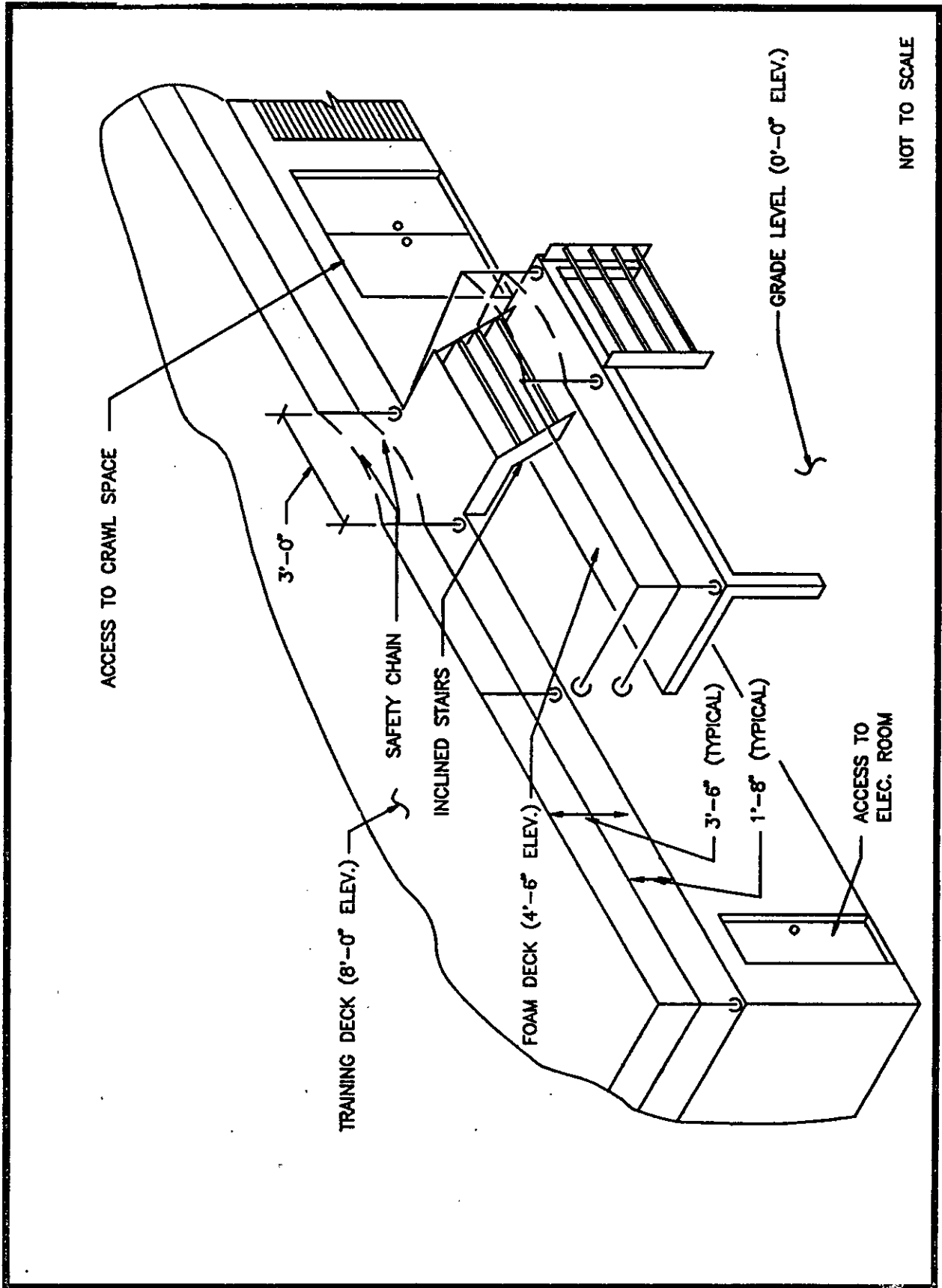

Figure E-7
Training and Foam Deck Railing

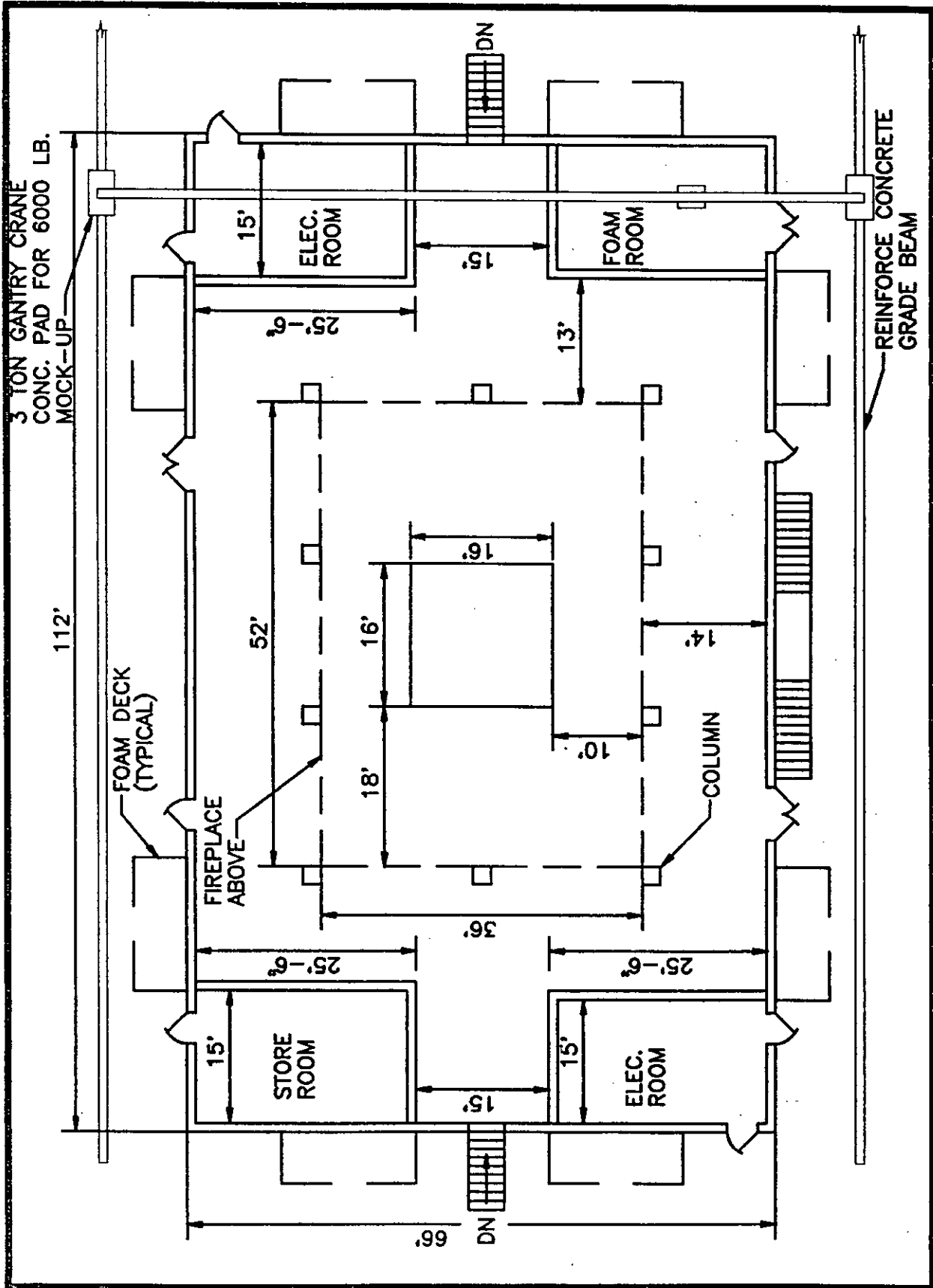

Figure E-8
19F4/19F4A Crawlspace Plan and Pedestal

MIL-HDBK-1027/1

APPENDIX F
19F5 AND 19F5A STRUCTURES

19F5/19F5A
19F5/19F5A

First Floor Plan
Elevation

F-1
F-2

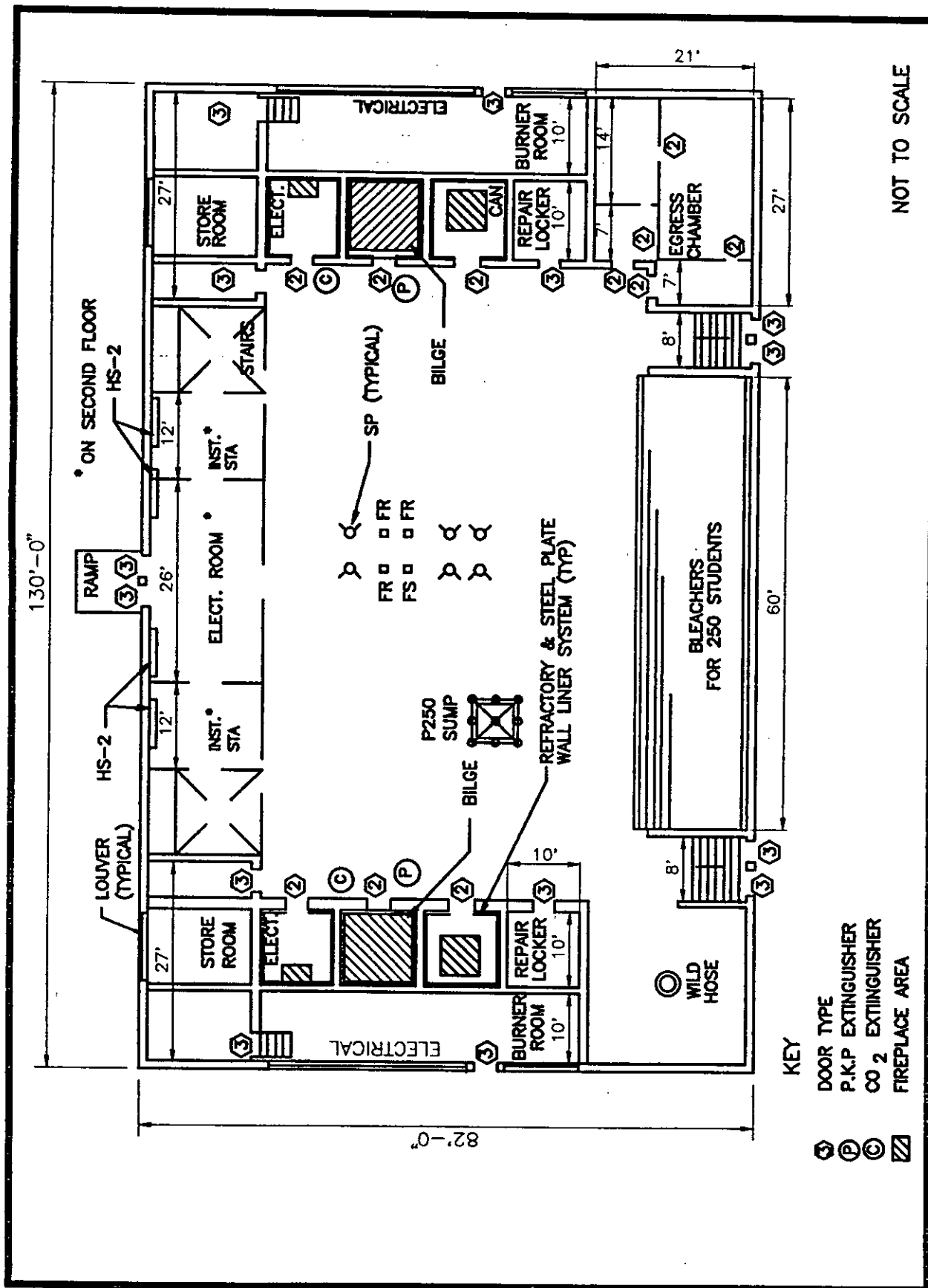

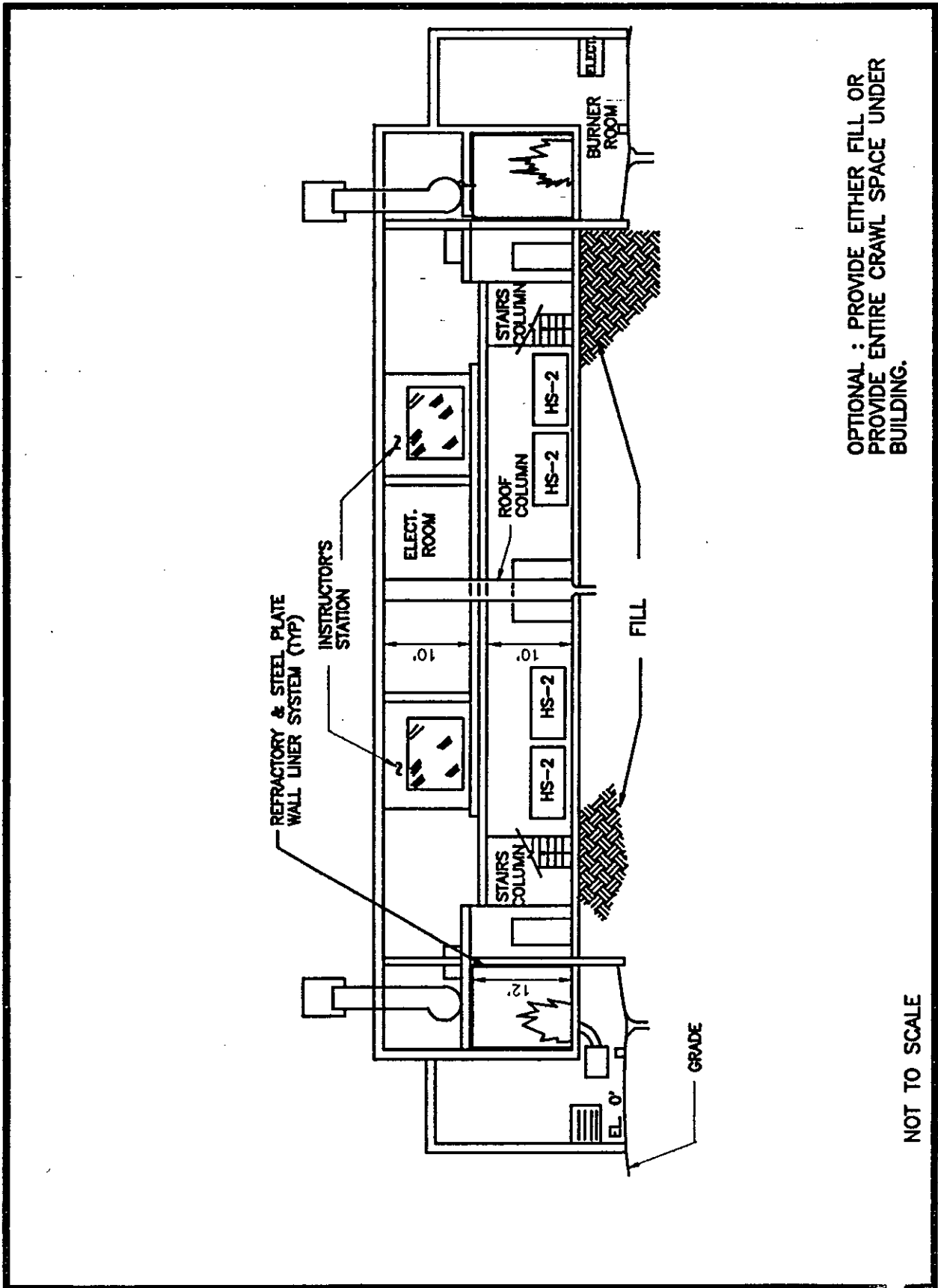

OPTIONAL : PROVIDE EITHER FILL OR PROVIDE ENTIRE CRAWL SPACE UNDER BUILDING.

NOT TO SCALE

Figure F-2
19F5/19F5A Elevation

MIL-HDBK-1027/1

APPENDIX G
21C12 AND 21C12A STRUCTURES

21C12/21C12A	First Floor Plan	G-1
21C12/21C12A	Section A-A	G-2
21C12/21C12A	Section B-B	G-3
21C12/21C12A	Training Compartment/Equipment Mockup	G-4A-B
21C12/21C12A	OBA Canister Storage Rack	G-5
21C12/21C12A	EAB Cabinet	G-6
21C12/21C12A	OBA Locker	G-7
21C12/21C12A	Fire Hose Locker Wall Mounted	G-8
21C12/21C12A	Fire Hose Locker Floor Mounted	G-9
21C12/21C12A	AFFF Fill Station	G-10A-B
21C12/21C12A	EAB Outlet Housing	G-11
21C12/21C12A	Combined Hose Station	G-12A-F
21C12/21C12A	EAB System Schematic	G-13A-F
21C12/21C12A	Seawolf First Floor Plan	G-14A-B
21C12/21C12A	SHS4	G-15A-C
21C12/21C12A	Seawolf Water and AFFF System Schematic	G-16
21C12/21C12A	And Seawolf Propane Alarm System Schematic	G-17

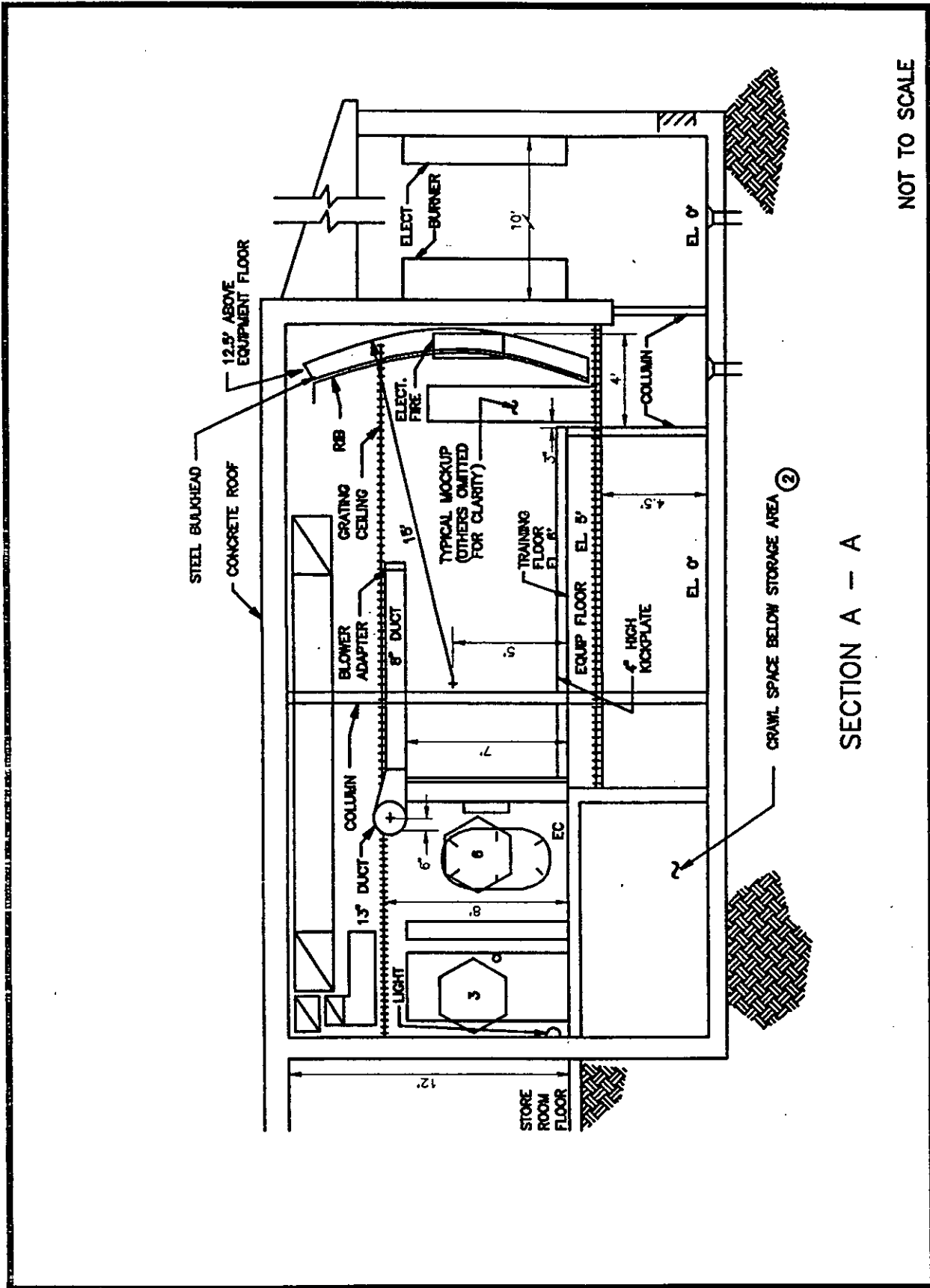

NOT TO SCALE

SECTION A - A

Figure G-2
21C12/21C12A Section

MIL-HDBK-1027/1

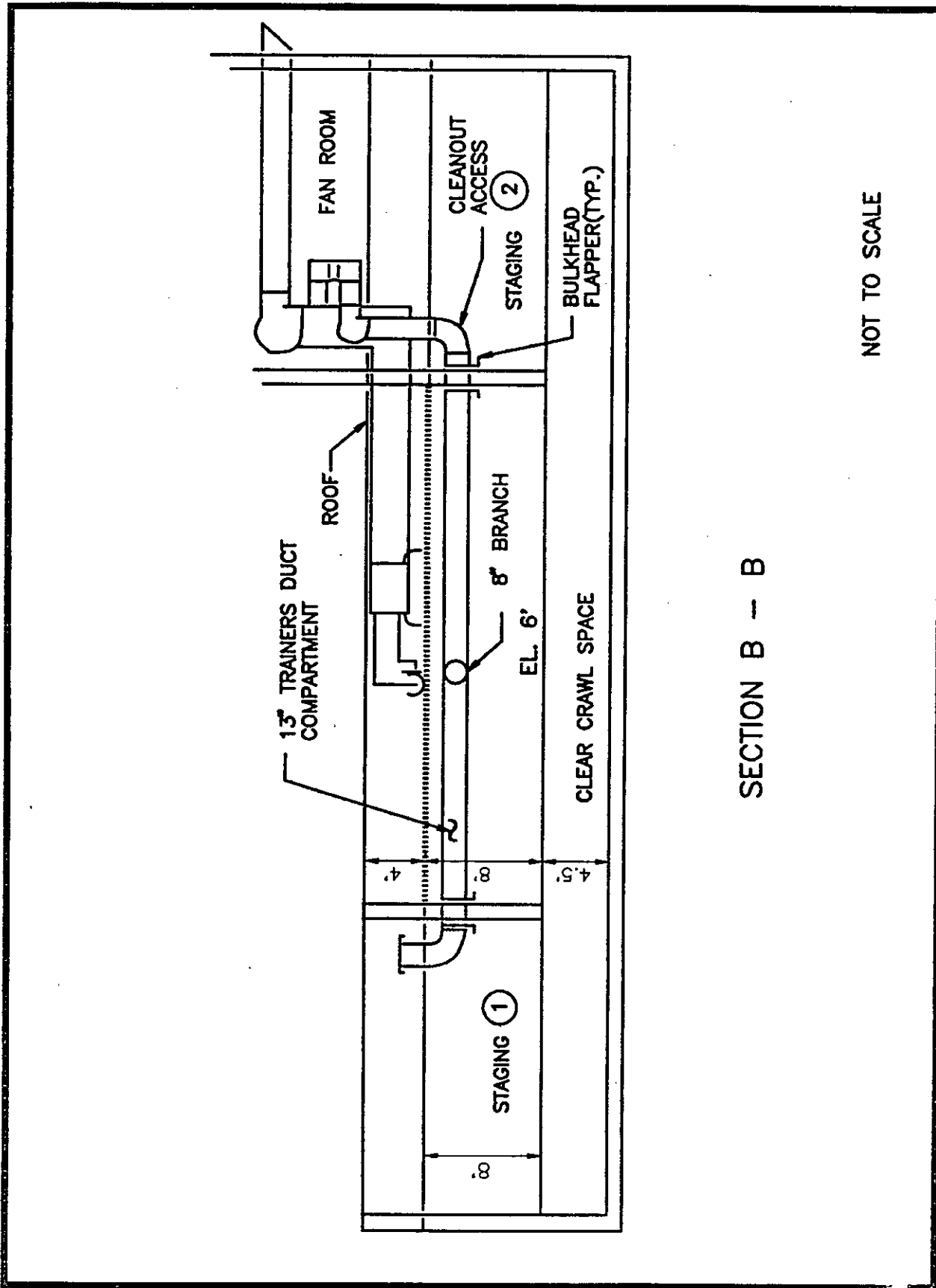

SECTION B -- B

NOT TO SCALE

Figure G-3
21C12/21C12A Section

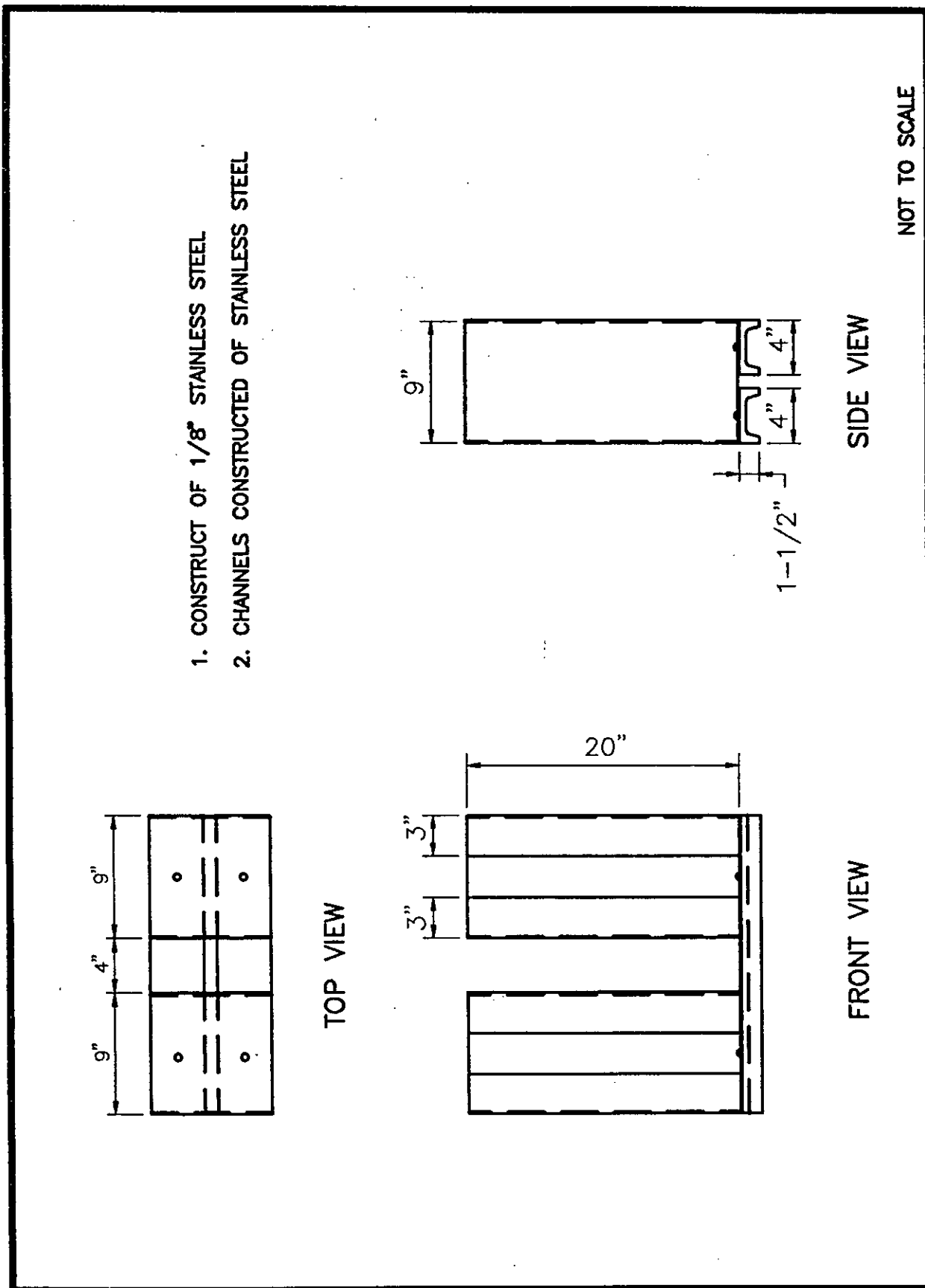

Figure G-5
21C12/21C12A OBA Canister Storage Rack

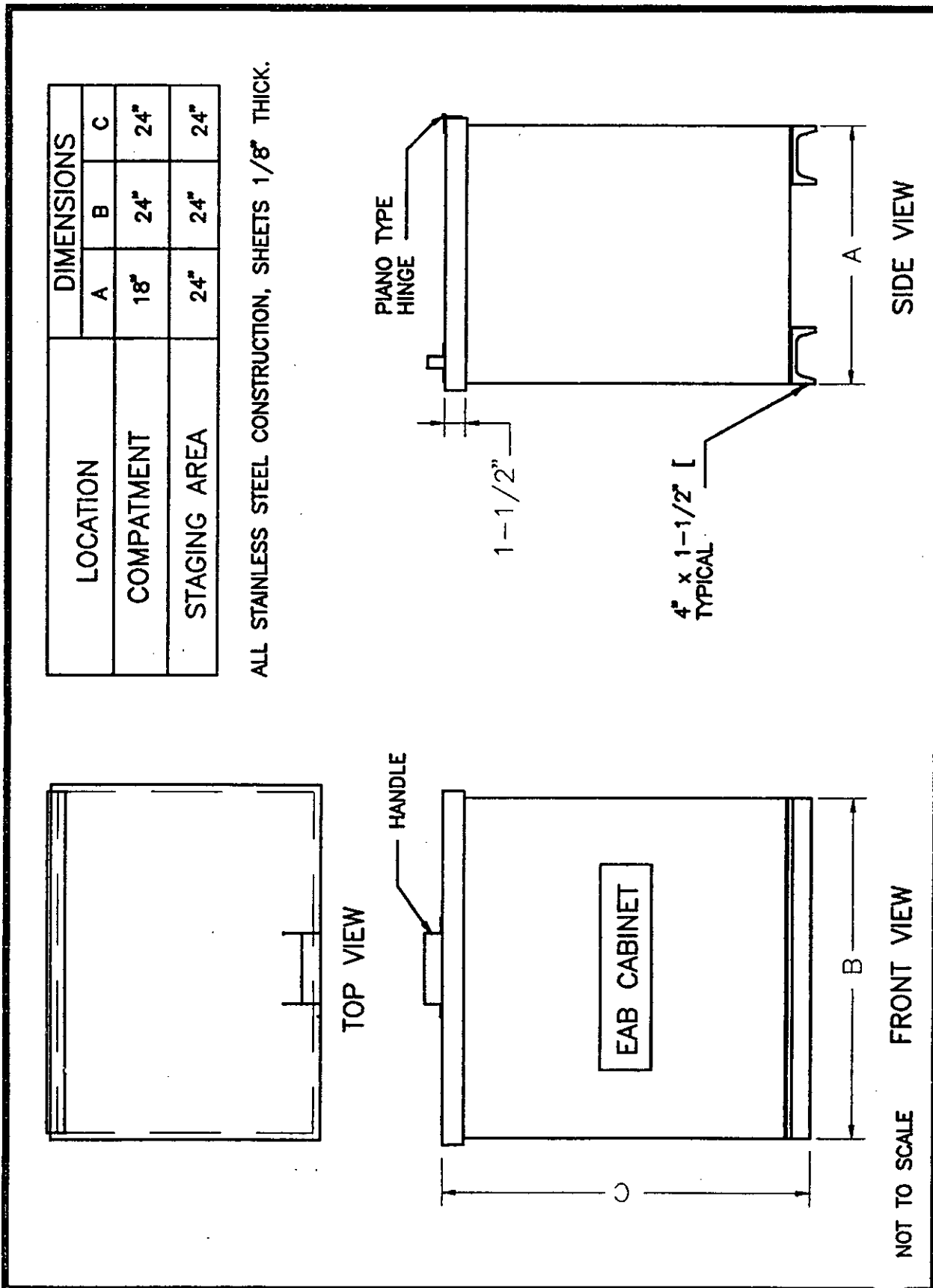
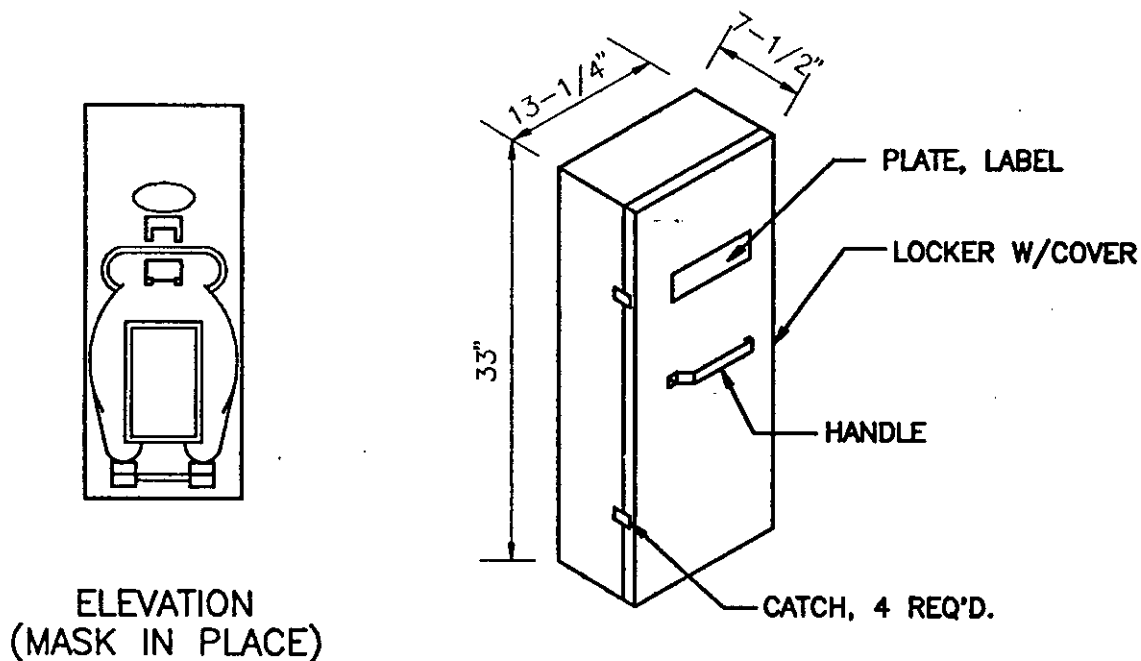

Figure G-6
21C12/21C12A EAB Cabinet

MIL-HDBK-1027/1



ELEVATION
(MASK IN PLACE)

ISOMETRIC VIEW

NOTE :
PROVIDE 10 LOCKERS
IN EACH STAGING AREA .

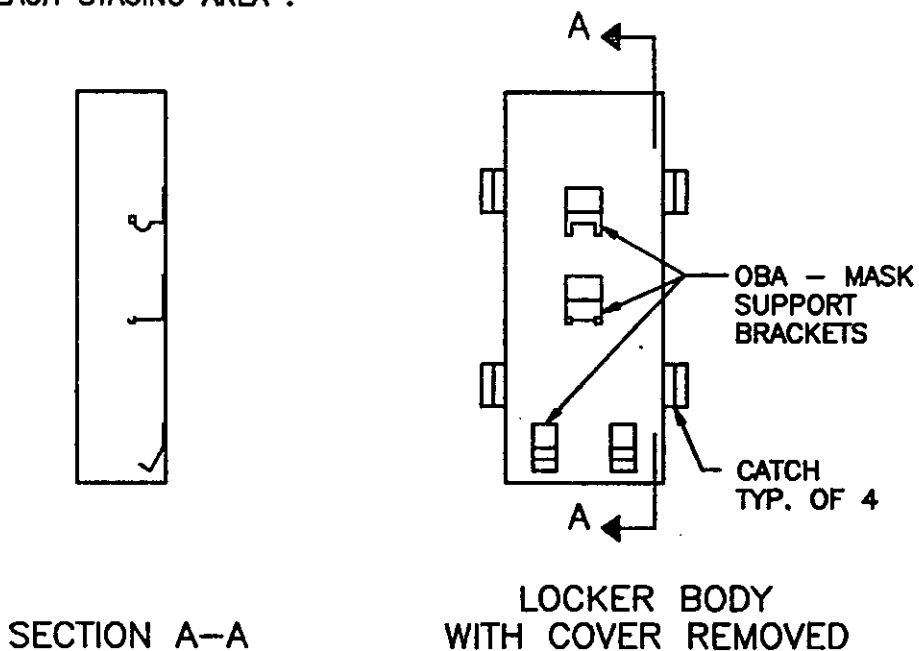

SECTION A-A

LOCKER BODY
WITH COVER REMOVED

NOT TO SCALE

Figure G-7
21C12/21C12A OBA Locker

MIL-HDBK-1027/1

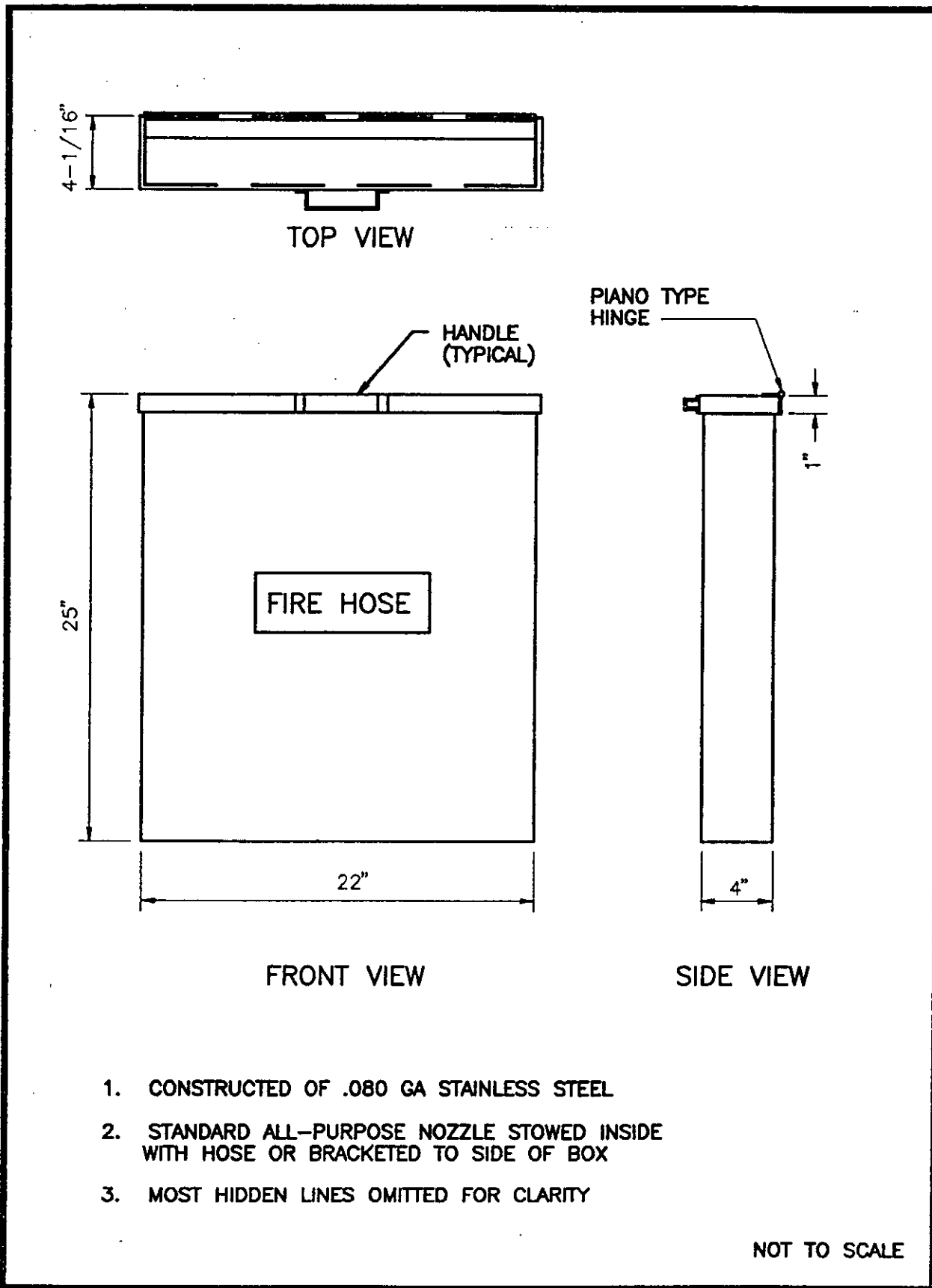

Figure G-8
21C12/21C12A Fire Hose Locker Wall Mounted

MIL-HDBK-1027/1

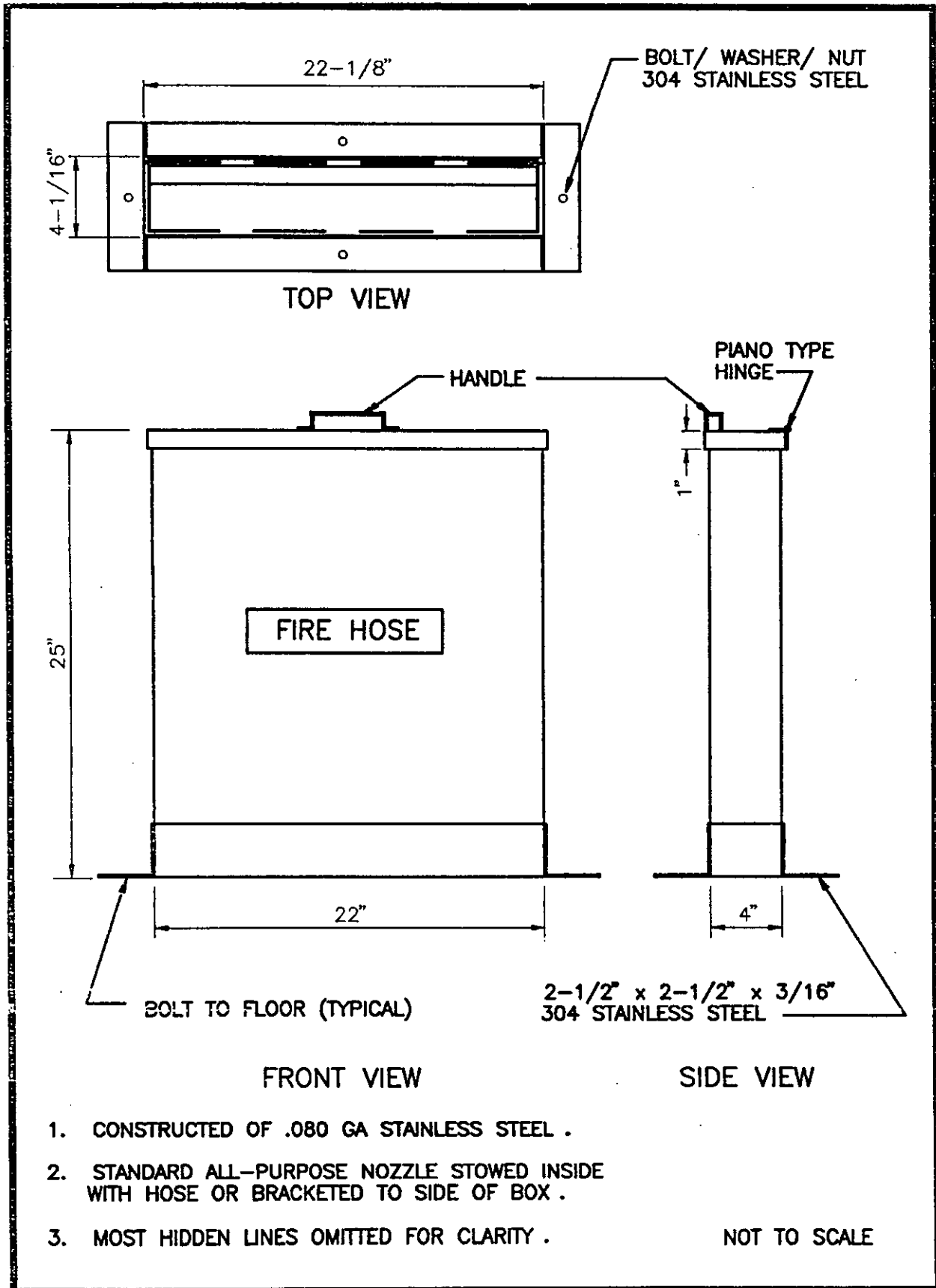

Figure G-9
21C12/21C12A Fire Hose Locker Floor Mounted

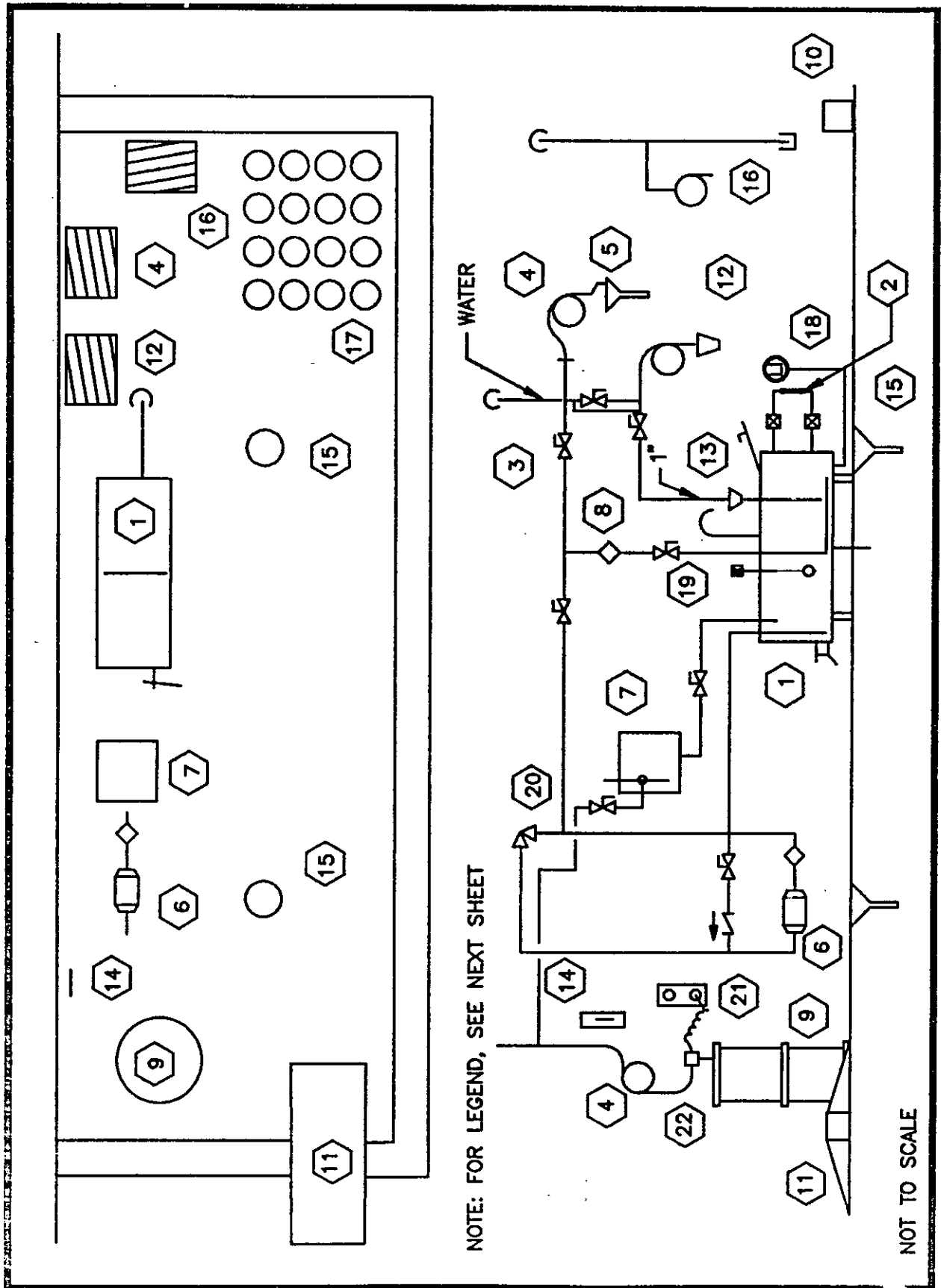



Figure G-10A
AFFF Fill Station

MIL-HDBK-1027/1

LEGEND

1. TANK, 300 GALLONS WITH TOP AND LARGE LID;
3/4" DRAIN (3% AFF SOLUTION)
2. SIGHT GLASS
3. BALL VALVE, TYPICAL
4. 1/2" HOSE 10' LONG; RACK
5. TRIGGER VALVE WITH 3' LONG, 1/2" TUBE; NO NOZZLE
6. INLINE PUMP 10 GPM AT 20' HEAD
7. MEASURING TANK 10 GALLONS
8. SQUARE HEAD COCK
9. 55 GALLON DRUM
10. SPILL PREVENTION CURB
11. MOUNTABLE CURB
12. 1/2" HOSE 20' LONG WITH NOZZLE; RACK
13. OPEN SITE WATER FILL
14. PUMP START SWITCH
15. FLOOR DRAIN, TYPICAL
16. SHOP AIR STATION WITH 10' HOSE
17. EMPTY EXTINGUISHERS
18. LIQUID LEVEL INDICATOR
19. LOW LEVEL PUMP SHUT OFF
20. RELIEF VALVE
21. 110 VOLT RECEPTICAL FOR 
22. DRUM PUMP

NOTE

1. ALL CONSTRUCTION SHALL BE CORROSION RESISTANT METAL
2. ALL PIPE SIZES ARE 3/4" UNLESS INDICATED OTHERWISE

Figure G-10B
AFFF Fill Station

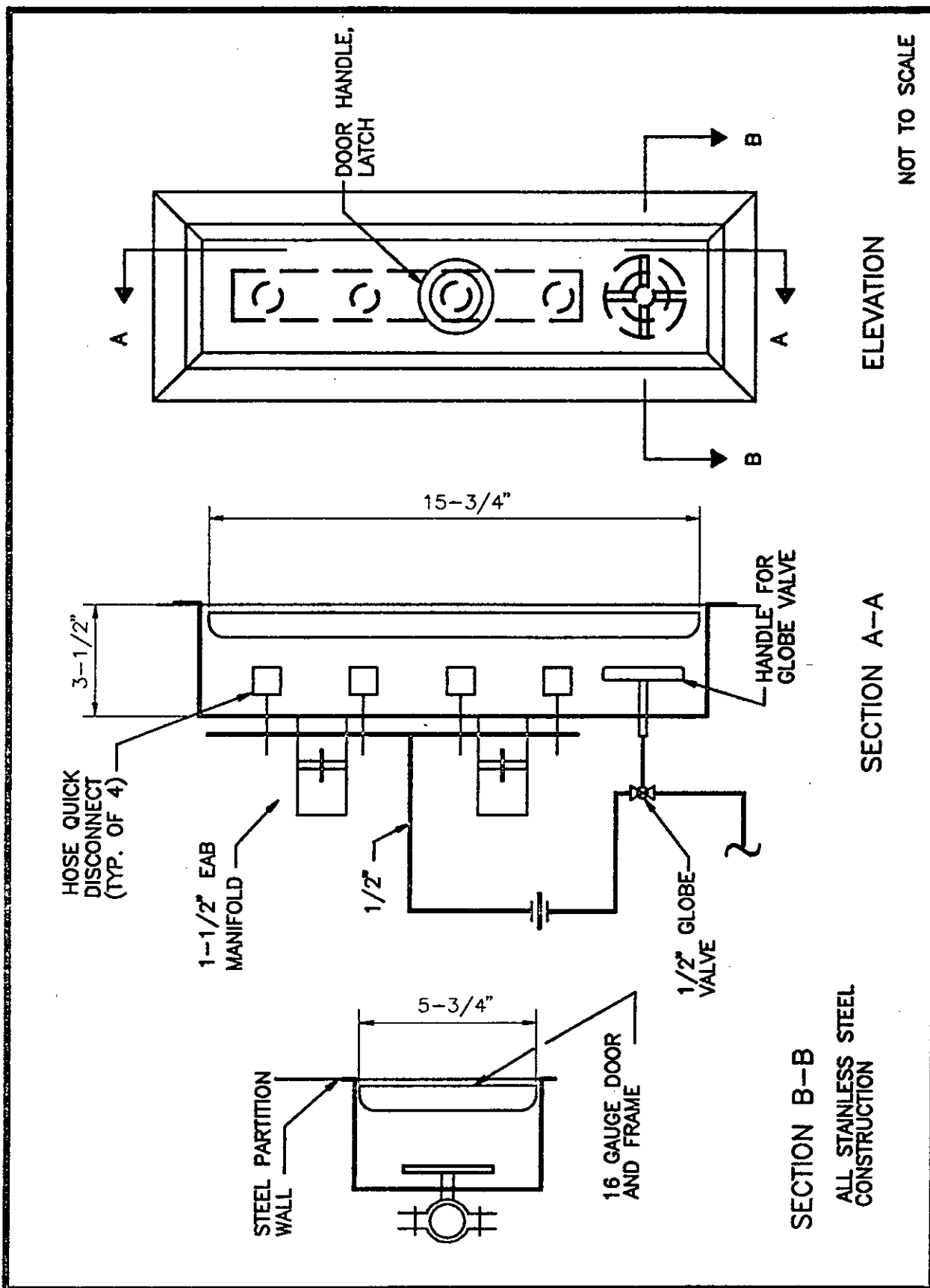

Figure G-11
21C12/21C12A EAB Outlet Housing

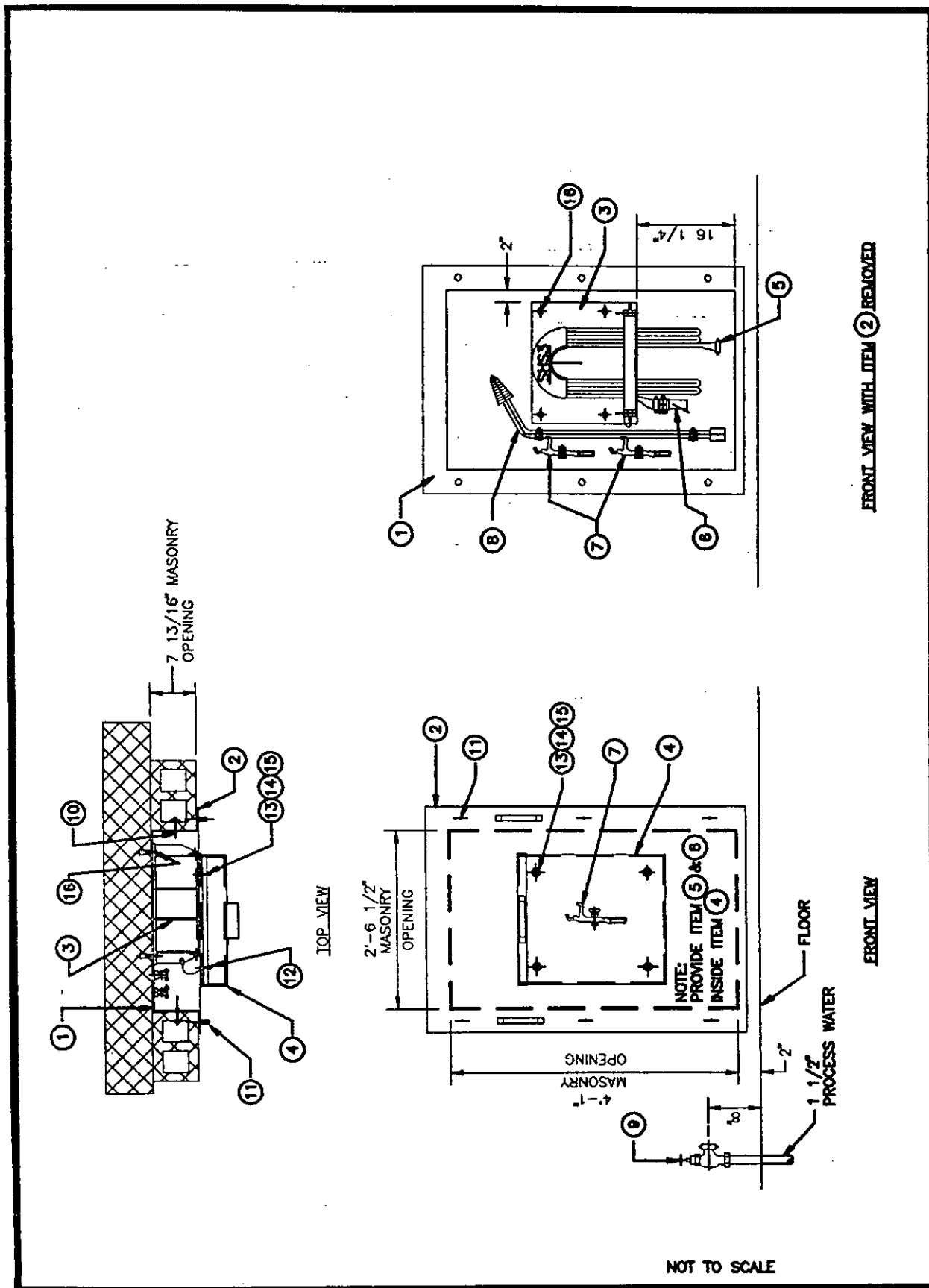

Figure G-12A
Combined Hose Station

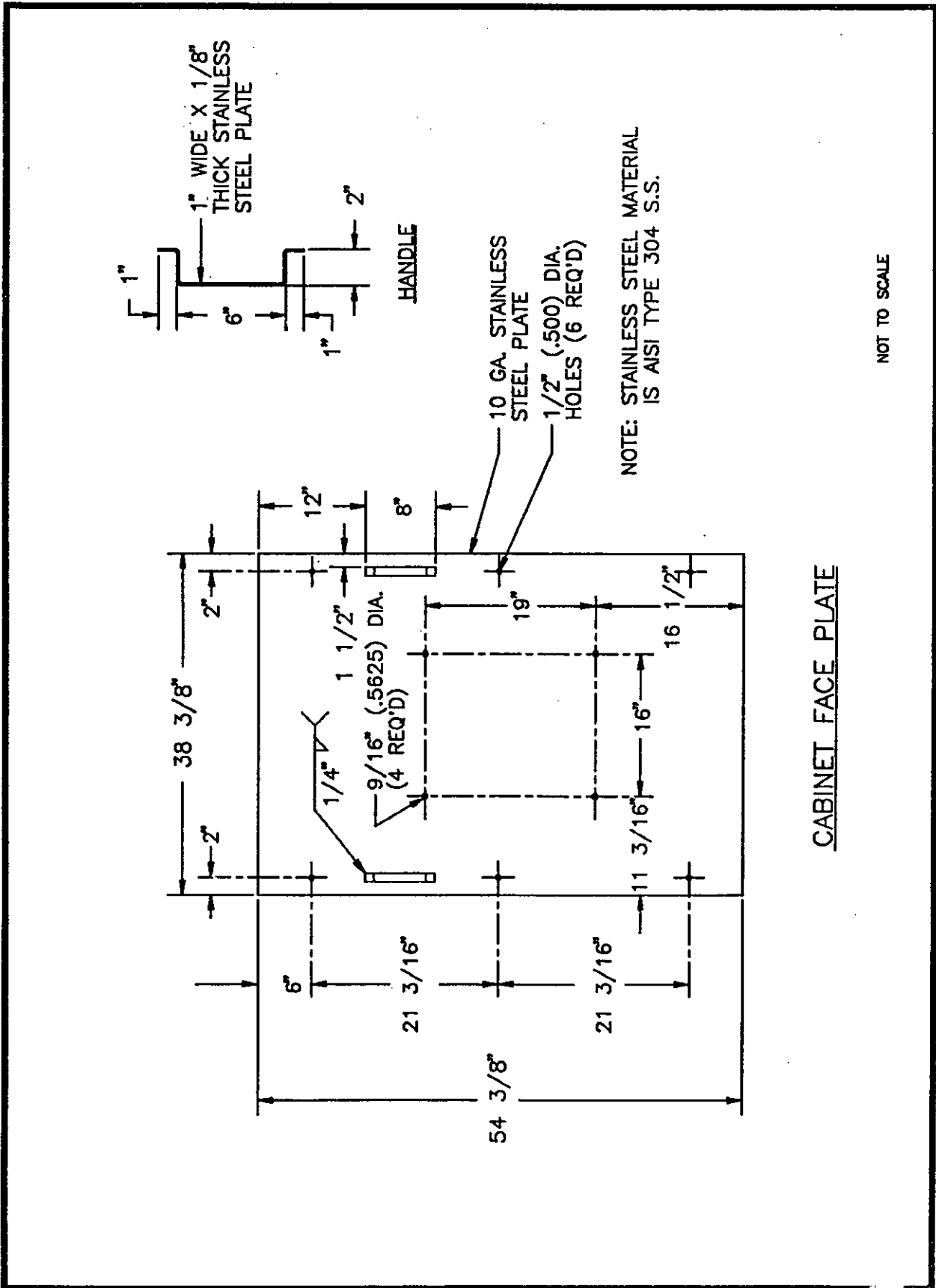

Figure G-12B
Combined Hose Station

MIL-HDBK-1027/1

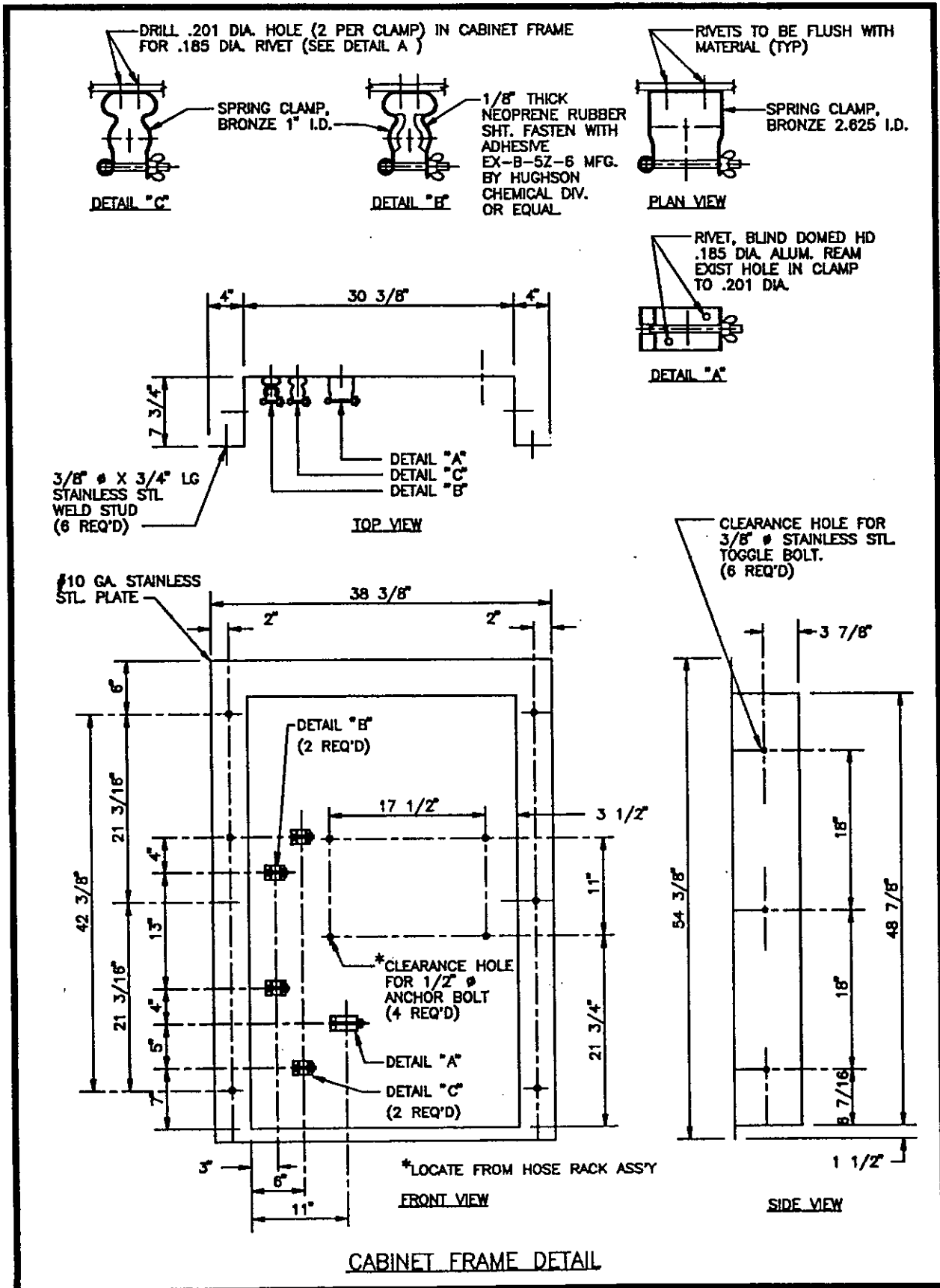

Figure G-12C
Combined Hose Station

MIL-HDBK-1027/1

LIST OF MATERIALS

ITEM	QTY.	DESCRIPTION	REF. DRAWINGS
1	1	CABINET FRAME ASSY.	
2	1	CABINET FACE PLATE	
3	1	HOSE RACK ASSY.	
4	1	FIRE HOSE LOCKER ASSY	
5	2	FIRE HOSE - 1-1/2" X 25' LONG	MIL-H-24606
6	2	FIRE HOSE NOZZLE - BRASS STYLE - 2069	NAVSHIPS 810-1385834
7	3	SPANER WRENCH STYLE 46	NAVSHIPS 810-4444647
8	1	APPLICATOR - 410 - STYLE 2069	NAVSHIPS 810-1385834
9	1	WALL OR FLOOR MTD. 1-1/2" HOSE ANGLE GLOBE VALVE, ONE END FLANGED. ONE END MALE THREADED WITH HOSE CAP AND CHAIN. BRONZE 1-1/2"	NAVSEA 803-1385711
10	6	3/8" ϕ S.S. TOGGLE BOLTS 4-1/2" LONG	
11	6	3/8" ϕ S.S. WING NUTS	
12	4	1/2" THICK SPACER - S.S.	
13	4	1/2" S.S. NUT	
14	4	1/2" S.S. LOCK WASHER	
15	4	1/2" ϕ BOLT - 1-1/4" LONG	
16	4	1/2" ϕ ANCHOR BOLTS	

NOTE: STAINLESS STEEL MATERIAL IS AISI TYPE 304 S.S.

Figure G-12D
Combined Hose Station

MIL-HDBK-1027/1

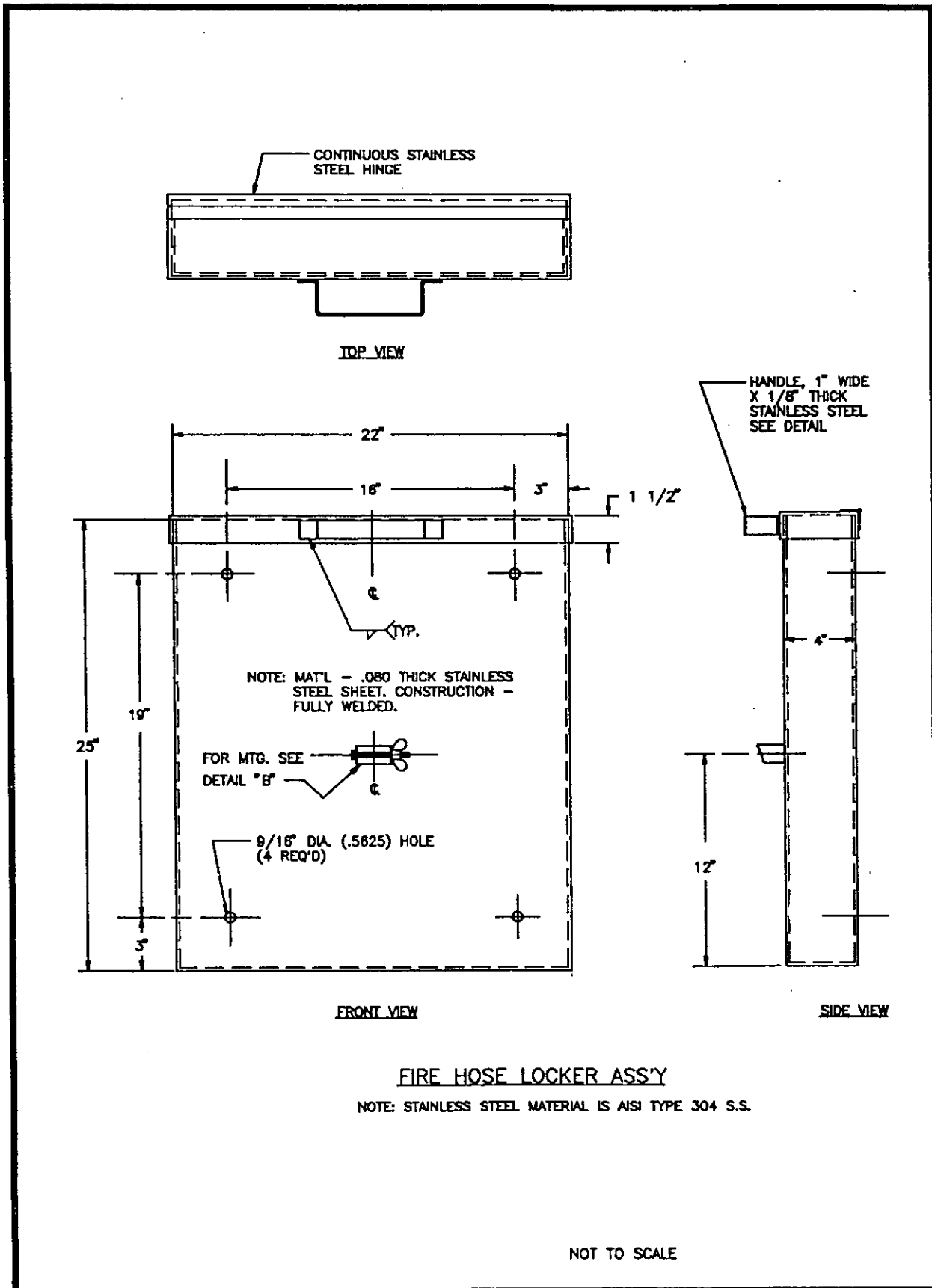

Figure G-12E
Combined Hose Station

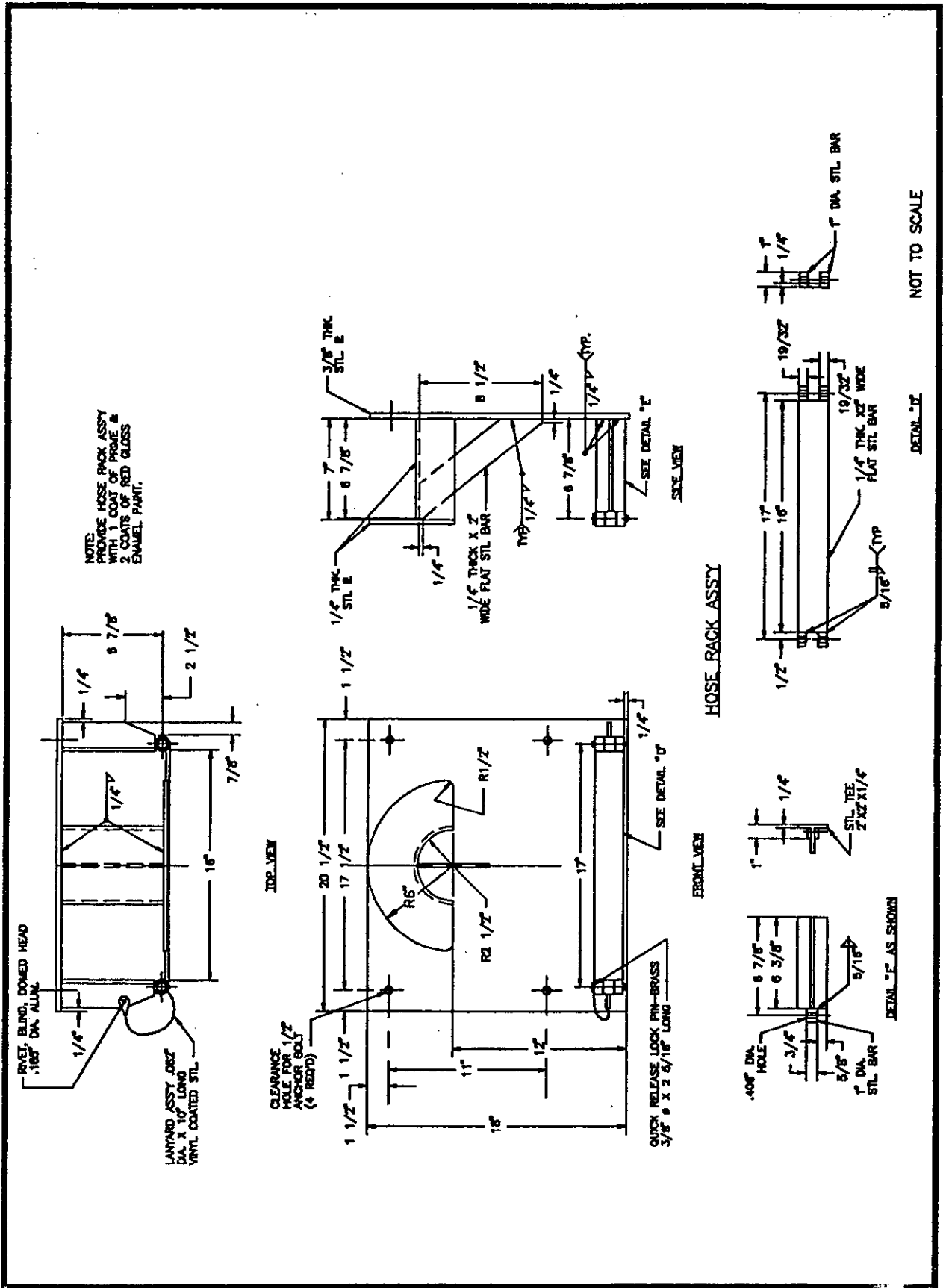

Figure G-12F
 Combined Hose Station

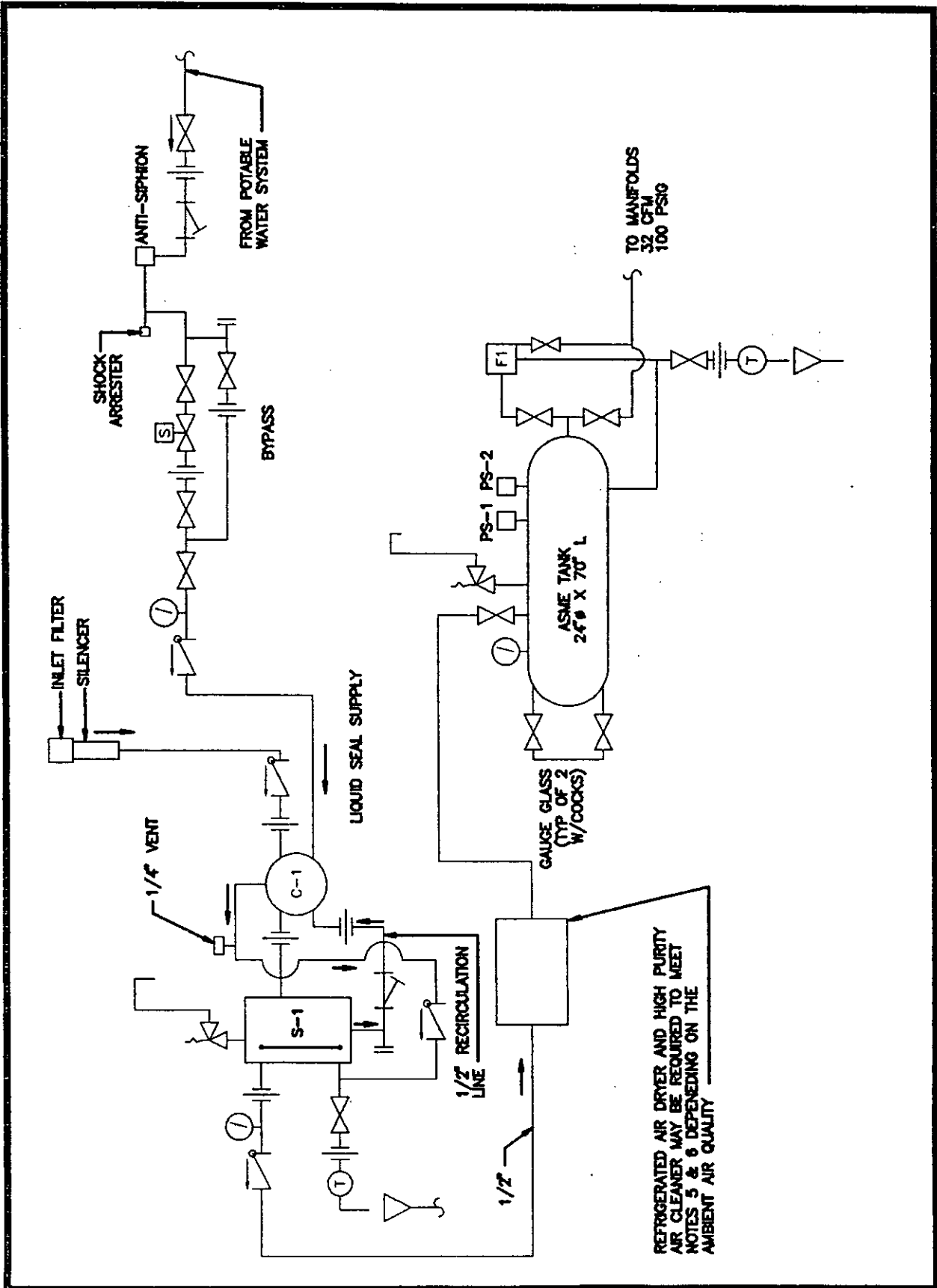
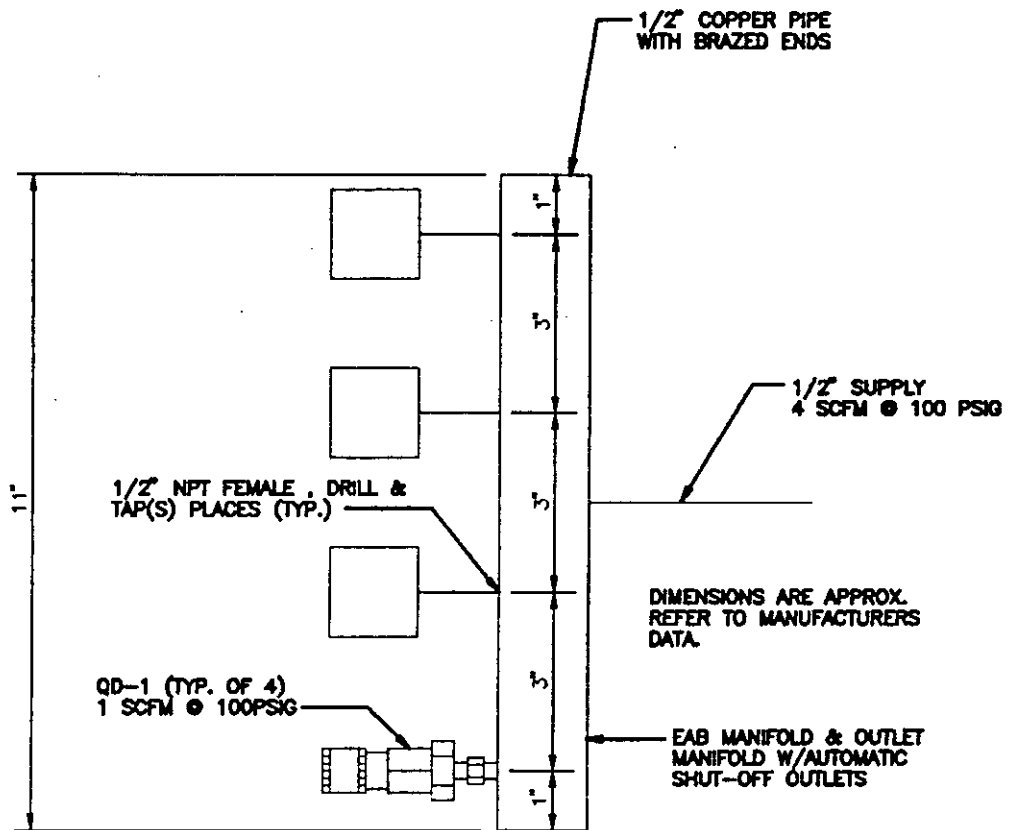

Figure G-13A
EAB System Schematic



QD-1: QUICK DISCONNECT CONNECTION
& COUPLING (SCOVILL) SHALL
BE SUITABLE FOR A MSA P/N
55716 ADAPTER.

EAB MANIFOLD

NO SCALE

Figure G-13B
EAB System Schematic

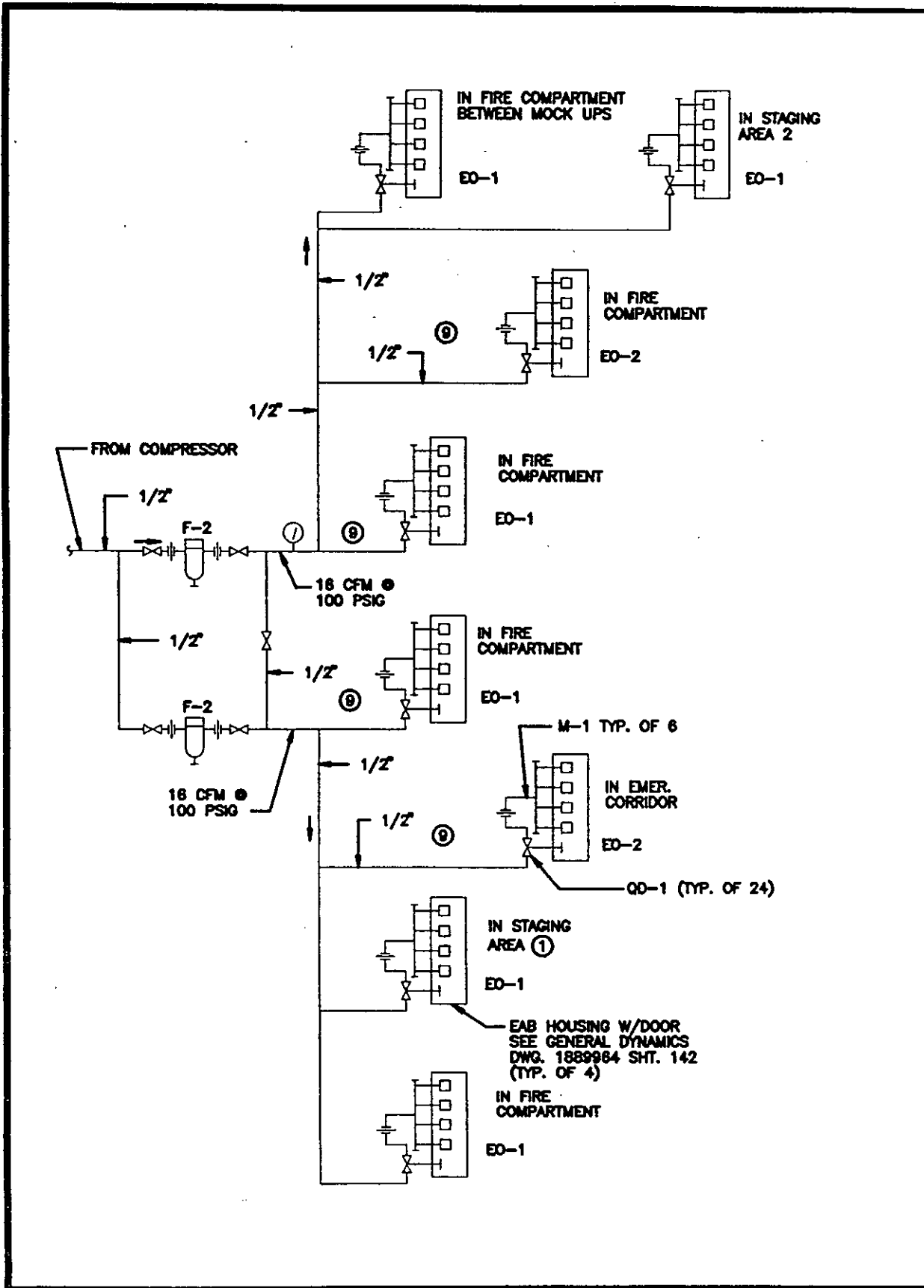

Figure G-13C
EAB System Schematic

NOTES

- S ① THE ENTIRE SYSTEM SHALL BE HYDROSTATICALLY TESTED TO 150 PSIG. NO LEAKAGE ALLOWABLE.
- D ② ALL VALVES AT EAB MANIFOLD SHALL BE COLOR CODED TAN.
- C ③ HIGH POINT VENTS AND LOW POINT DRAINS SHALL BE PROVIDED AND SHOWN ON DWGS.
- D ④ SYSTEM SHALL WORK WITH THE FOLLOWING DEMAND RESPIRATORS AND REGULATORS:
 RESPIRATOR: 1 SCFM.
 MSA NO. G978315 OR SAC NO. 25901
 MSA: MINE SAFETY APPLANCE OR
 SAC: SCOTT AVIATION CORP.
 REGULATOR: 1 SCFM
 MSA NO: G981070
 SAC NO: 25900
 HOSE: 8' RUBBER
 MSA NO: 85570
 MALE ADAPTER MSA P/N 55716
- D ⑤ PIPING SHALL BE CLEANED TO REMOVE GREASE, OIL, FLUX, & FOREIGN OR LOOSE PARTICLES. THE SYSTEM SHALL BE CLEANED SO THAT THE BREATHING AIR FROM THE SYSTEM MEETS FED. SPEC. BB-A-1043A & AM#1. SOURCE II. GRADE D.
- D S ⑥ SYSTEM SHALL BE DESIGNED TO MEET THE FOLLOWING: FED. SPEC. BB-A-1034A & AM#1 GRADE D ANSI Z 86.1 & COMPRESSED AIR AND VACUUM SYSTEMS NFCS 15403 NON-FLAMMABLE MEDICAL GAS SYSTEM.
- ⑦ SYSTEM IS TESTED TWICE PER YEAR PER FED. SPEC.
- C ⑧ 35 PSIG MINIMUM POTABLE WATER REQUIRED AT COMPRESSOR FOR SEALS. 5 PSIG MINIMUM RECIRCULATED WATER REQUIRED AT COMPRESSOR.
- C ⑨ EAB PIPING TO EAB MANIFOLDS IN EMERGENCY COORIDORS & FIRE COMPARTMENTS SHALL BE ROUTED BELOW THE EMERGENCY COORIDOR FLOOR IN THE CRAWL SPACE.
- D ⑩ THE EAB SYSTEM SHALL BE DESIGNED USING THIS SCHEMATIC AS A GUIDE. THE DESIGNER SHALL PREPARE DETAILED DESIGN AND DRAWINGS OF THE EAB SYSTEM INCLUDING A DWG. SHOWING THE SCHEMATIC AND ALL CONTROLS.
- ⑪ EAB SYSTEM SHALL BE TESTED AND CERTIFIED BY THE EFD IN ACCORDANCE TO FED SPEC.

Figure G-13D
EAB System Schematic

MIL-HDBK-1027/1

PIPING LEGEND













	POTABLE WATER-COPPER
	AIR GAPE FUNNEL
	GATE VALVE-BRONZE FED. SPEC. WW-V-54, CLASS 150
	GLOBE VALVE-BRONZE FED. SPEC. WW-V-51, CLASS 150
	CHECK VALVE-BRONZE
	ELECTRIC SOLENOID VALVE-BRONZE CLASS 150
	UNION
	ORIFCE UNION-BRONZE
	STRAINER-BRONZE
	AIR PIPING-COPPER ASTM B55, TYPE K
	RELIEF VALVE-BRONZE
	QUICK DISCONNECT QD-1
	BALL FLOAT TRAP
	PRESSURE GAUGE
PS	PRESSURE SWITCH

Figure G-13E
EAB System Schematic

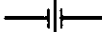
MIL-HDBK-1027/1

REVISION CHANGES

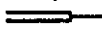
MOVED SOLENOID VALVE
 ADDED 2 EO-1 STATIONS
 ADDED NOTE 11
 CHANGED NOTE 6
 ADDED AIR PURIFIER

EQUIPMENT SCHEDULE

NO.	DESCRIPTION	REFERENCE	SOURCE OF SUPPLY
F-1	SEPARATOR W/ FLOAT VALVE DRAIN TRAP		COMMERICAL- NASH *
F-2	1/2" AIR FILTER W/1 PARTICULATE FILTER 0.3 MICRON @ 99.7% & 2 ORGANIC CHARCOAL FILTERS .23 SCFM CAPACITY		COMMERICAL- MINE SAFETY APPLIANCE CO.
S-1	SEPARATOR W/ FLOAT VALVE		COMMERICAL- NASH *
C-1	COMPRESSOR - 48 SCFM, 100 PSIG 25 HP, 3500 RPM MOTOR		COMMERICAL- NASH, MODEL OC-5C UNIT *
QD-1	QUICK DISCONNECT CONNECTION & COUPLING SHALL BE SUITABLE FOR A MALE ADAPTER (MSA P/N 55710) USED ON M-1		COMMERICAL- SCOVILL
M-1	FOUR OUTLET MANIFOLD ASSEMBLY (EAB MANIFOLD)		COMMERICAL- SCOTT AVIATION CORP.
EO-1	M-1 IN RECESSED CABINET		COMMERICAL- PROVIDE W/ DOOR
EO-2	M-1 W/O CABINET		COMMERICAL

*THE EAB COMPRESSOR UNIT SHALL BE AN
 OIL-LESS, SINGLE-STAGE, POSITIVE DISPLACEMENT,
 NON-PULSATING, LIQUID RING TYPE: NAS-
 ENGINEERING CO. MODEL OC-5C OR EQUAL

D EAB EQUIPMENT:(GOVERNMENT FURNISHED)

MINE SAFETY APPLIANCE CO. MODEL 85570, 8' LONG RUBBER LONG
 WITH DEMAND REGULATOR 1 SCFM REDUCES AIR PRESSURE
 FROM 100 PSIG TO 2 PSIG & DEMAND FLOW RESPIRATOR WITH
 ALL VISION FACE PIECE, 1 SCFM @ 2 PSIG

NOTE LEGEND

D- NOTES FOR APPLYING TO DWG
 S- NOTE FOR SPECIFICATION REQUIREMENT
 C- DESIGN COMMENTS FOR DESIGNER

Figure G-13F
 EAB System Schematic

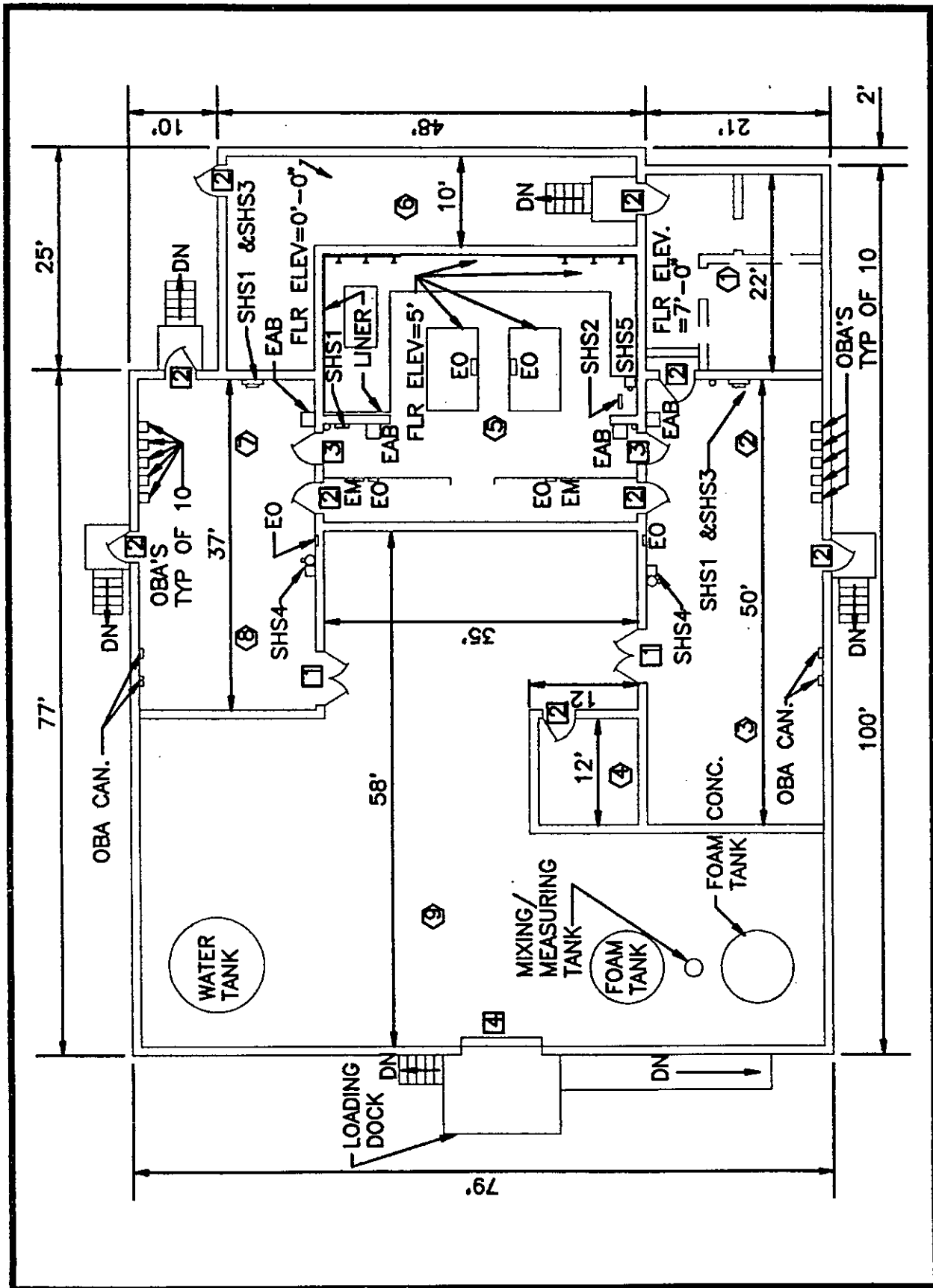

Figure G-14A
Seawolf First Floor Plan

ROOM SCHEDULE		
MARK	NAME	REMARKS
①	INSTRUCTOR'S STAT	1. PARTITIONS TO BE SUPPLIED BY DEVICE CONTR. 2. RAISED ACCESS FLOORING
②	STAGING AREA 1	
③	READY STORAGE 1	
④	DEVICE MAINTENANCE CONTRACTOR AREA	
⑤	FIRE COMPARTMENT	SEE FIG. G-2,3 & 4 FOR FURTHER DETAILS
⑥	BURNER ROOM	FLOOR ELEV= 0'-0"
⑦	STAGING AREA 2	
⑧	READY STORAGE 2	
⑨	BULK STORAGE & MECHANICAL ROOM	

LEGEND

EO EAB OUTLET SEE FIG. G-13
EM EAB MANIFOLD SEE FIG. G-13
EAB EAB CABINET SEE FIG. G-6
SHS1 SUBMARINE HOSE STATION #1 SEE FIG. G-8
SHS2 SUBMARINE HOSE STATION #2 SEE FIG. G-9
SHS3 SUBMARINE HOSE STATION #4 SEE FIG. G-15
SHS4 SUBMARINE HOSE STATION #2 SEE FIG. G-9
SHS5 SUBMARINE HOSE STATION #5
OBA OBA LOCKER SEE FIG. G-7
OBA CAN OBA CANISTER CONTAINER SEE FIG. G-5

① STD. 7'-0" WIDE DOUBLE DOOR
② STD. 4'-0" WIDE DOOR
③ SUBMARINE MOCK-UP DOOR
④ STD. 10'-0" WIDE ROLL-UP DOOR

Figure G-14B
Seawolf First Floor Plan

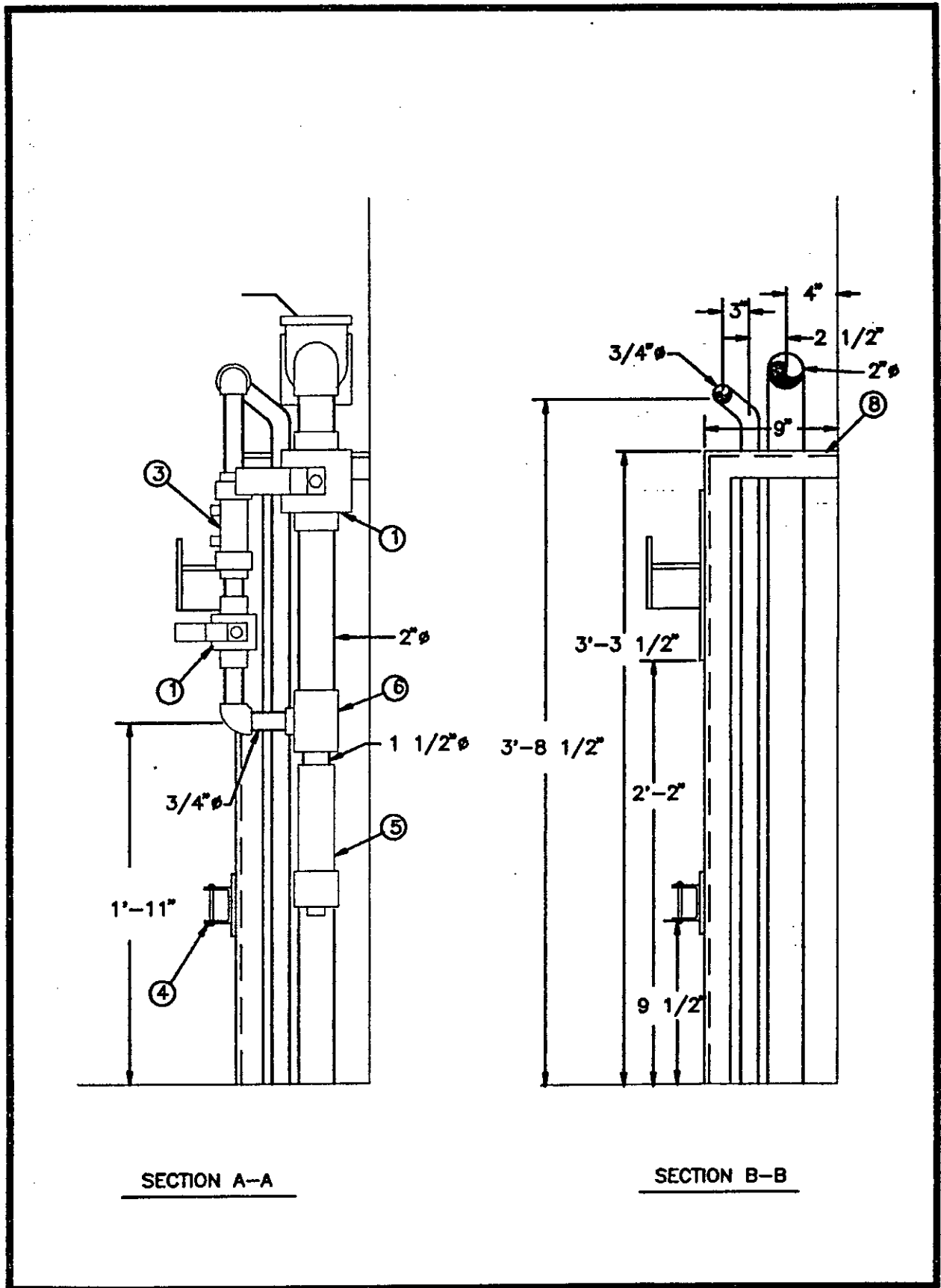

Figure G-15B
SHS 4

EQUIPMENT IDENTIFICATION		
NO.	DESCRIPTION	SOURCE OF SUPPLY
①	BALL VALVE	STD. COMM.
②	SWING CHECK VALVE	STD. COMM.
③	CONSTANT FLOW VALVE SET AT 3 GPM FOR PRESS. RANGE OF 8 TO 50 PSIG	GRISWOLD CONTROL MODEL 8738 F.A. (PROPRIETARY ITEM)
④	RACK, FIRE HOSE	SEE NAVSHIP DWG. 804-860089 FOR FURTHER DETAILS
⑤	HOSE ADAPTOR 1 1/2" - 1 1/2" NPSH x 1 1/2" IPS WITH CAP & CHAIN	STD. COMM.
⑥	2" x 1 1/2" x 3/4" TEE	STD. COMM.
⑦	24" x 4" x 3/4" PLATE	STD. COMM.
⑧	1 1/2" x 1 1/2" x 1/8" ANGLE	STD. COMM.

Figure G-15C
SHS 4

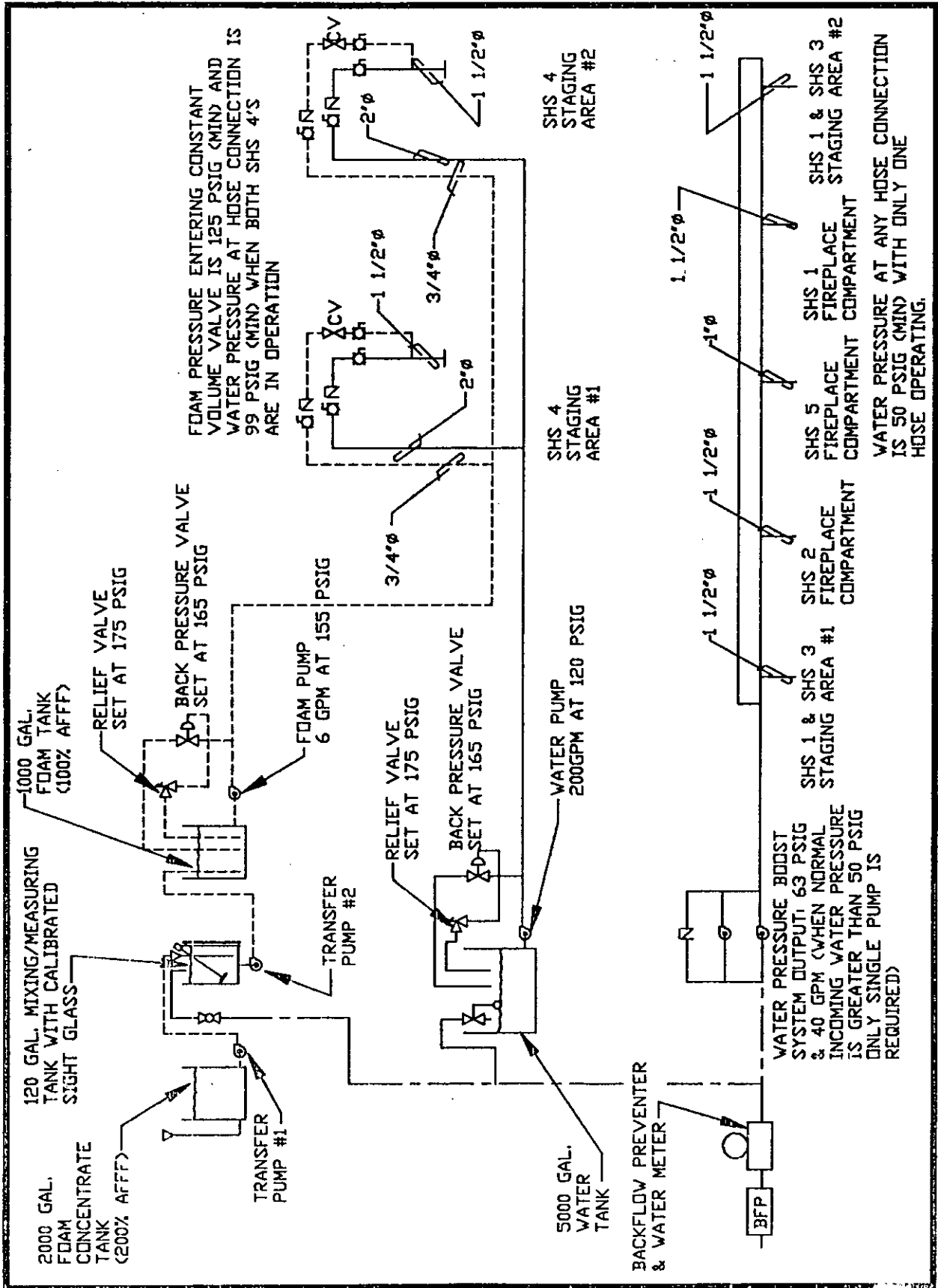

Figure G-16
Seawolf Water and AFFF System Schematic

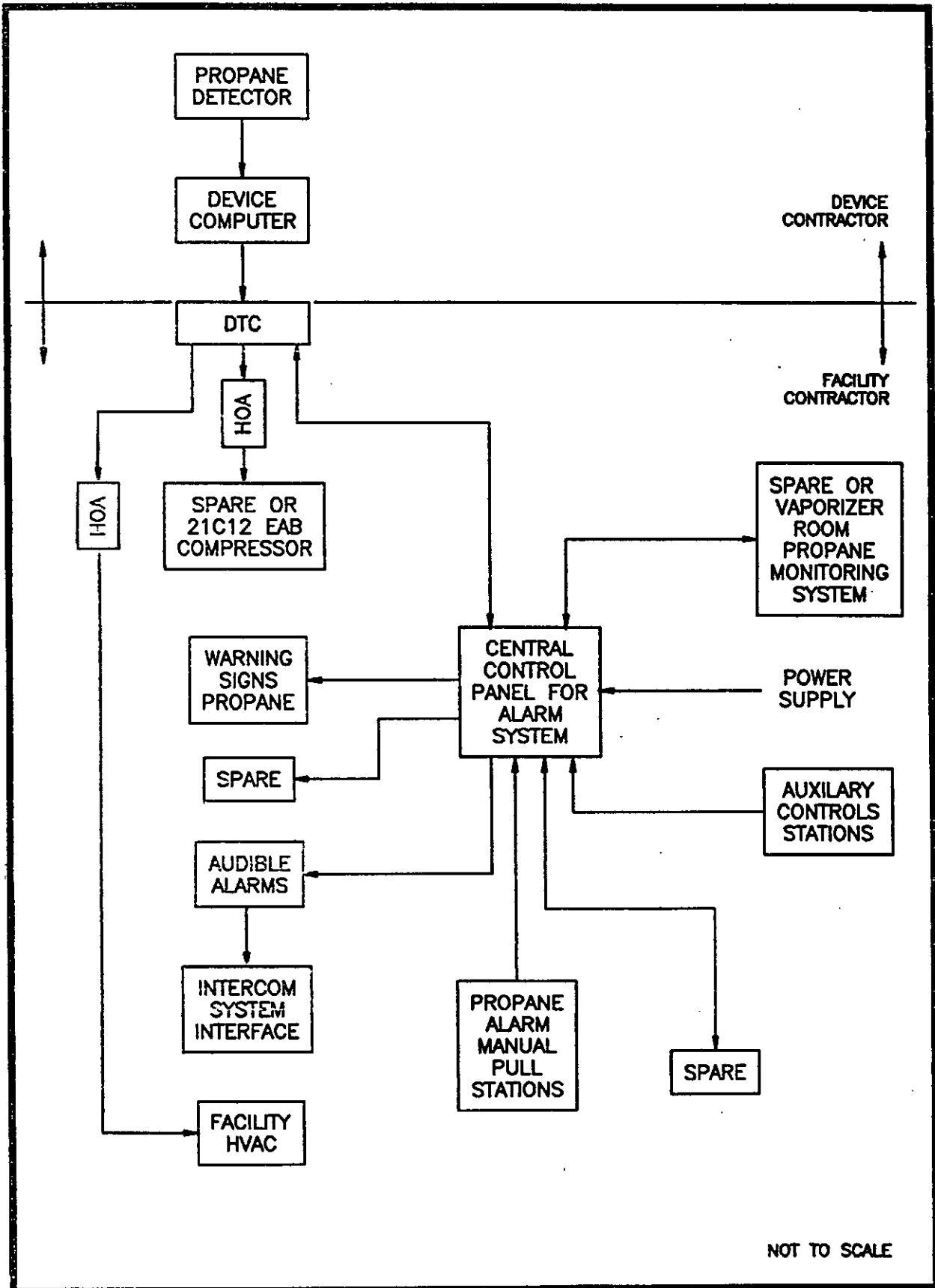

Figure G-17
21C12/21C12A and Seawolf Propane Alarm System Schematic

MIL-HDBK-1027/1

APPENDIX H
GAS CHAMBER

Gas Chamber Floor Plan
Gas Chamber Gas Mask Wall Storage

H-1
H-2

MIL-HDBK-1027/1

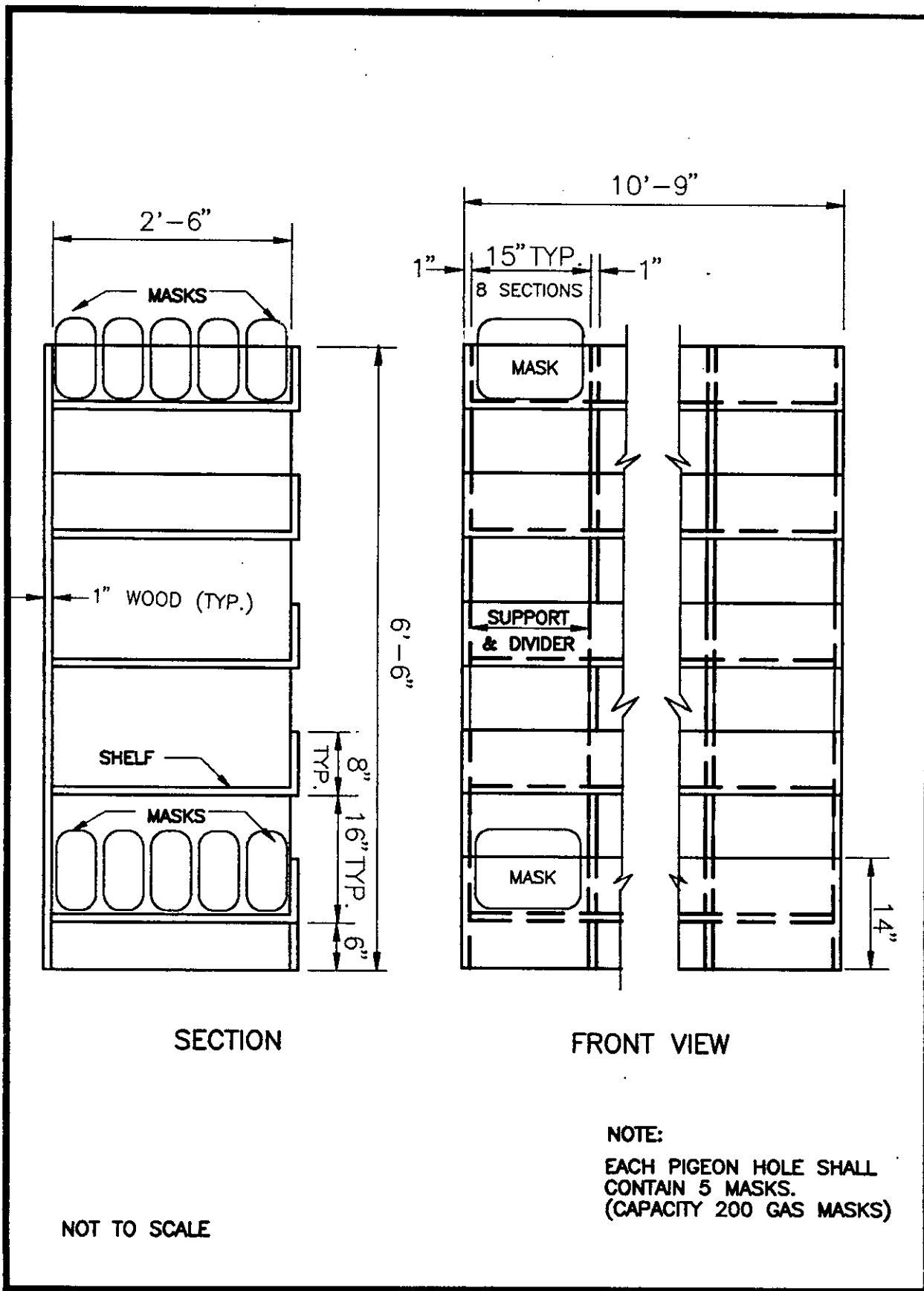
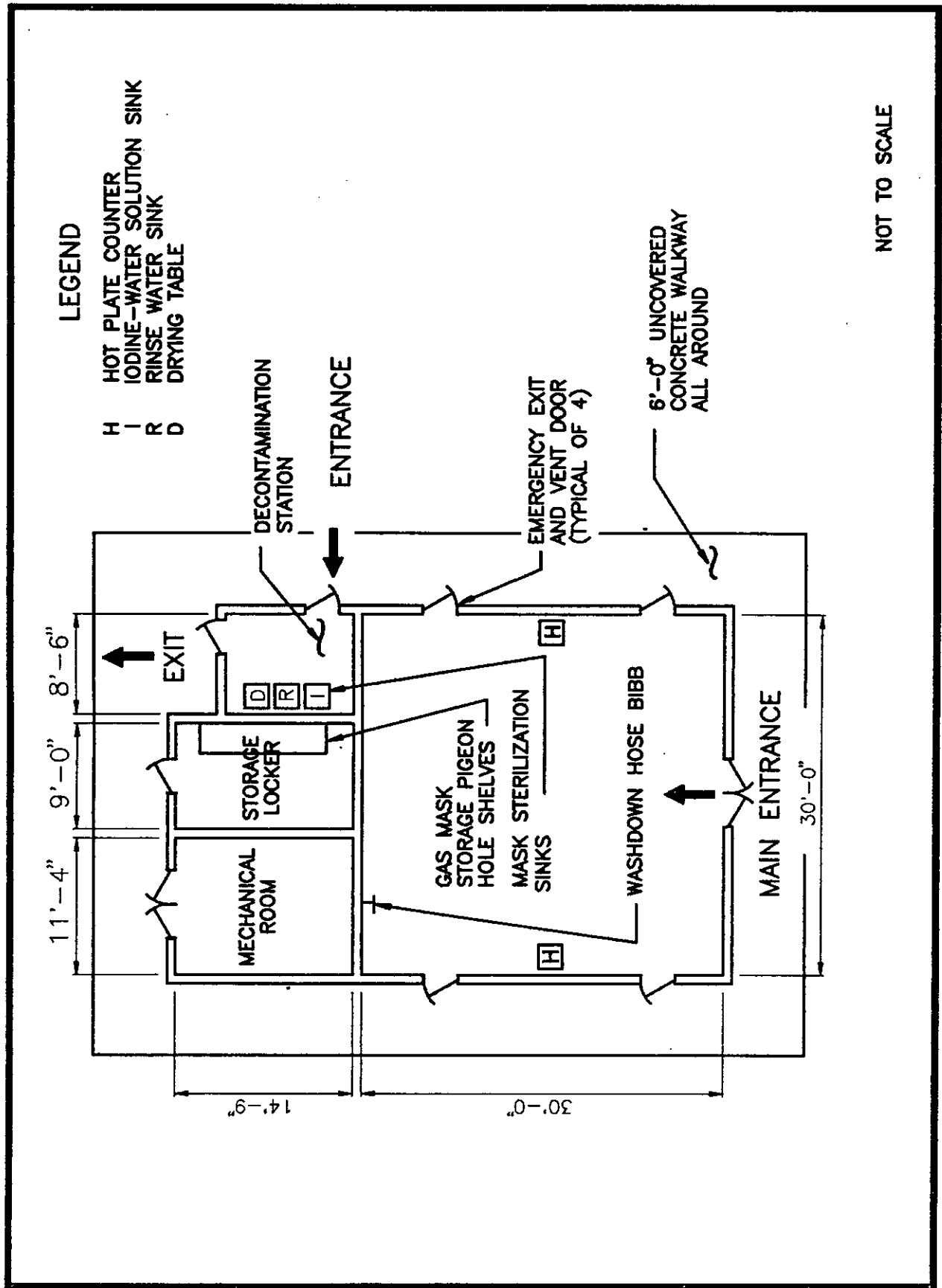

Figure H-1
Gas Chamber Gas mask Wall Storage



NOT TO SCALE

Figure H-2
Gas Chamber Floor Plan

MIL-HDBK-1027/1

APPENDIX I

CO₂

21C12/21C12A	CO ₂ Bulk Tank Details	I-1
21C12/21C12A	CO ₂ Schematics	I-2
21C12/21C12A	CO ₂ Schematics	I-3
21C12/21C12A	CO ₂ Manual Extinguisher Fill Pump	I-4
21C12/21C12A	CO ₂ Flow Schematic	I-5
21C12/21C12A	CO ₂ Wiring Schematic	I-6
21C12/21C12A	CO ₂ Legend	I-7

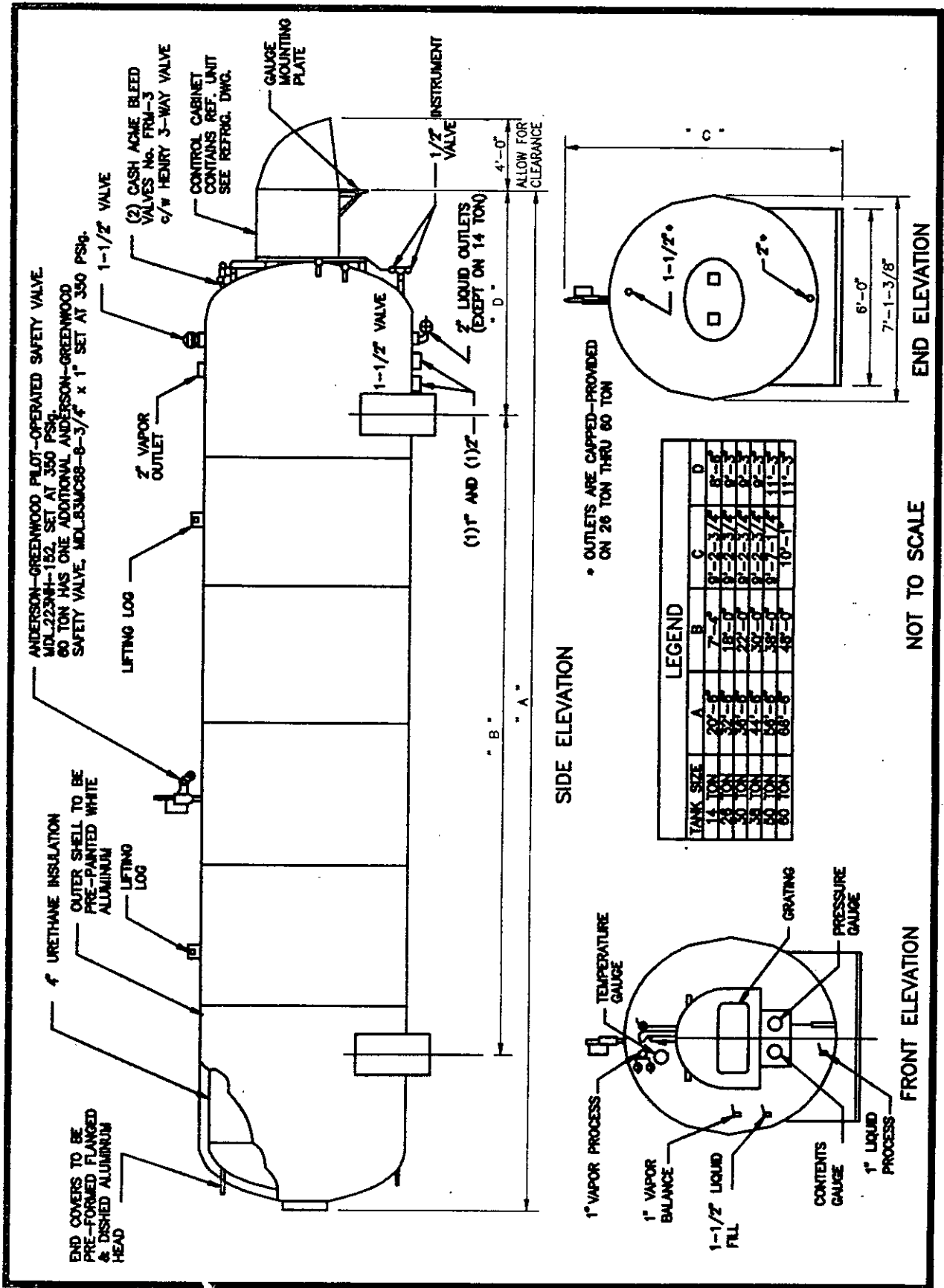

Figure I-1
21C12/21C12A CO₂ Bulk Tank Details

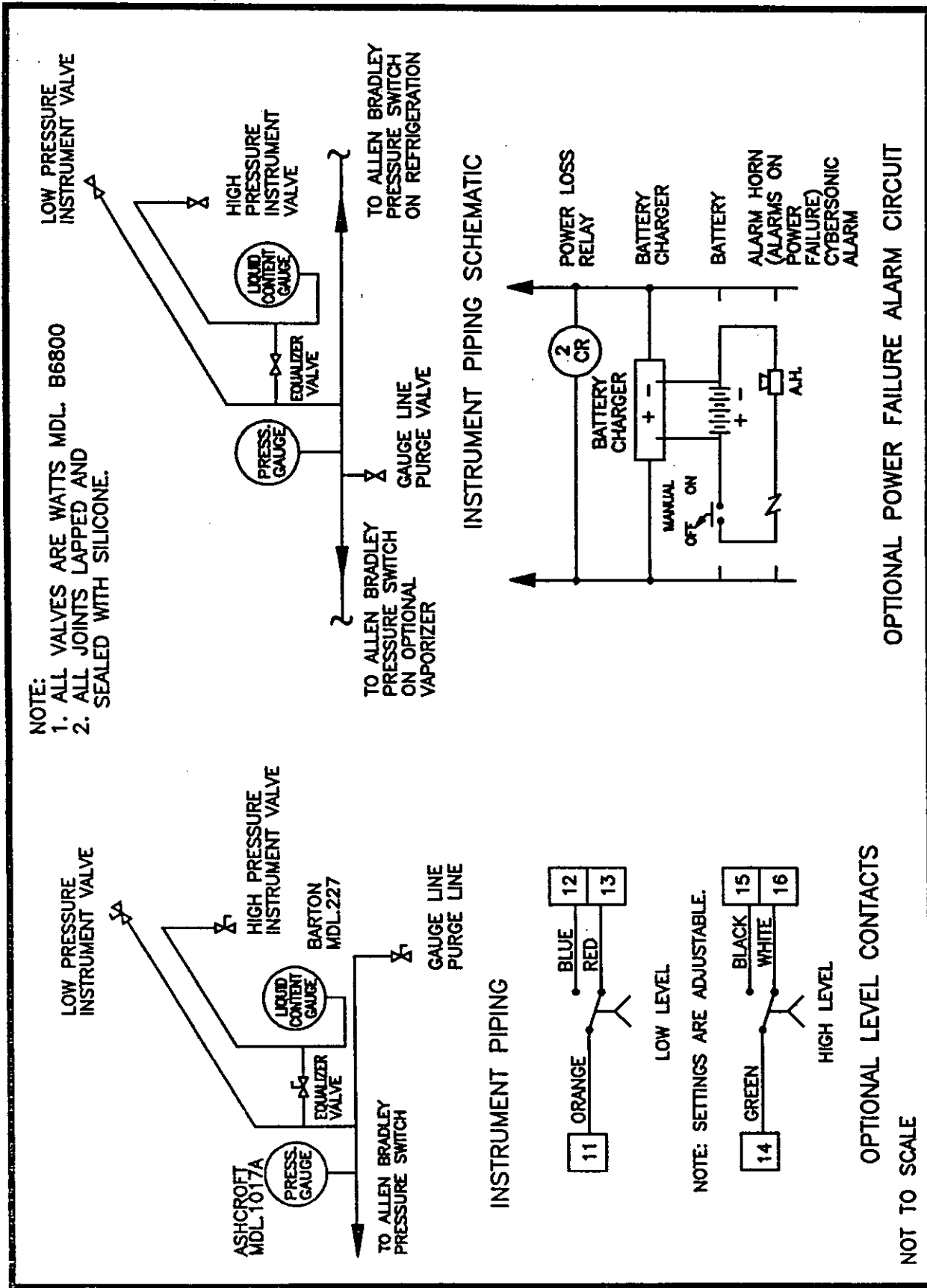
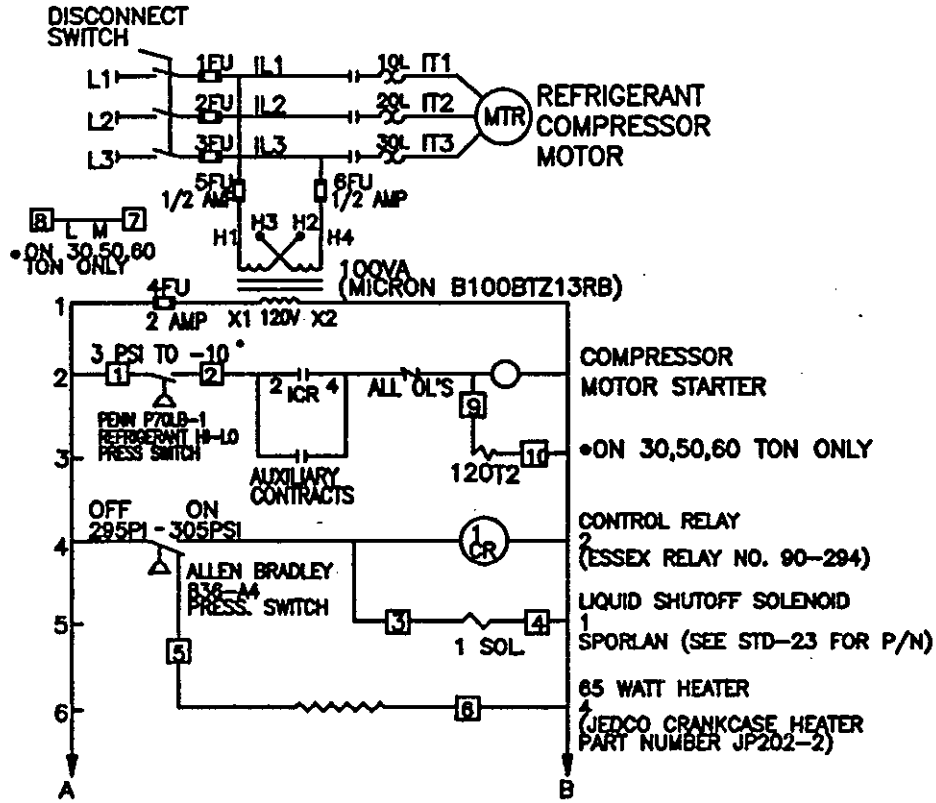
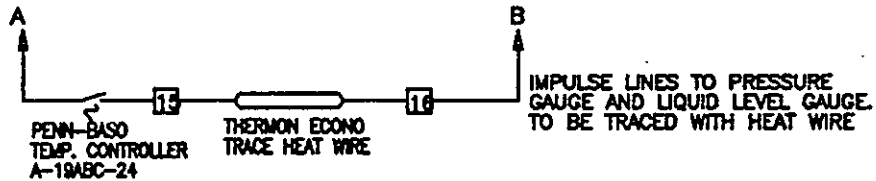

Figure I-2
 21C12/21C12A CO₂ Schematics



STANDARD REFRIGERATION SCHEMATIC
(MAIN FUSES SIZED ACCORDING TO VOLTAGE AND MOTOR SIZE)



OPTIONAL HEAT WIRE CIRCUIT

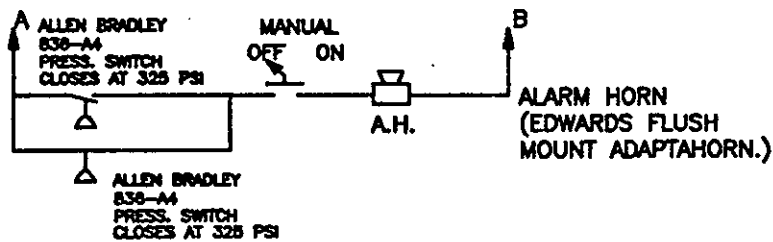

OPTIONAL HIGH AND LOW PRESSURE ALARM CIRCUIT

NOT TO SCALE

Figure I-3
21C12/21C12A CO₂ Schematics

MIL-HDBK-1027/1

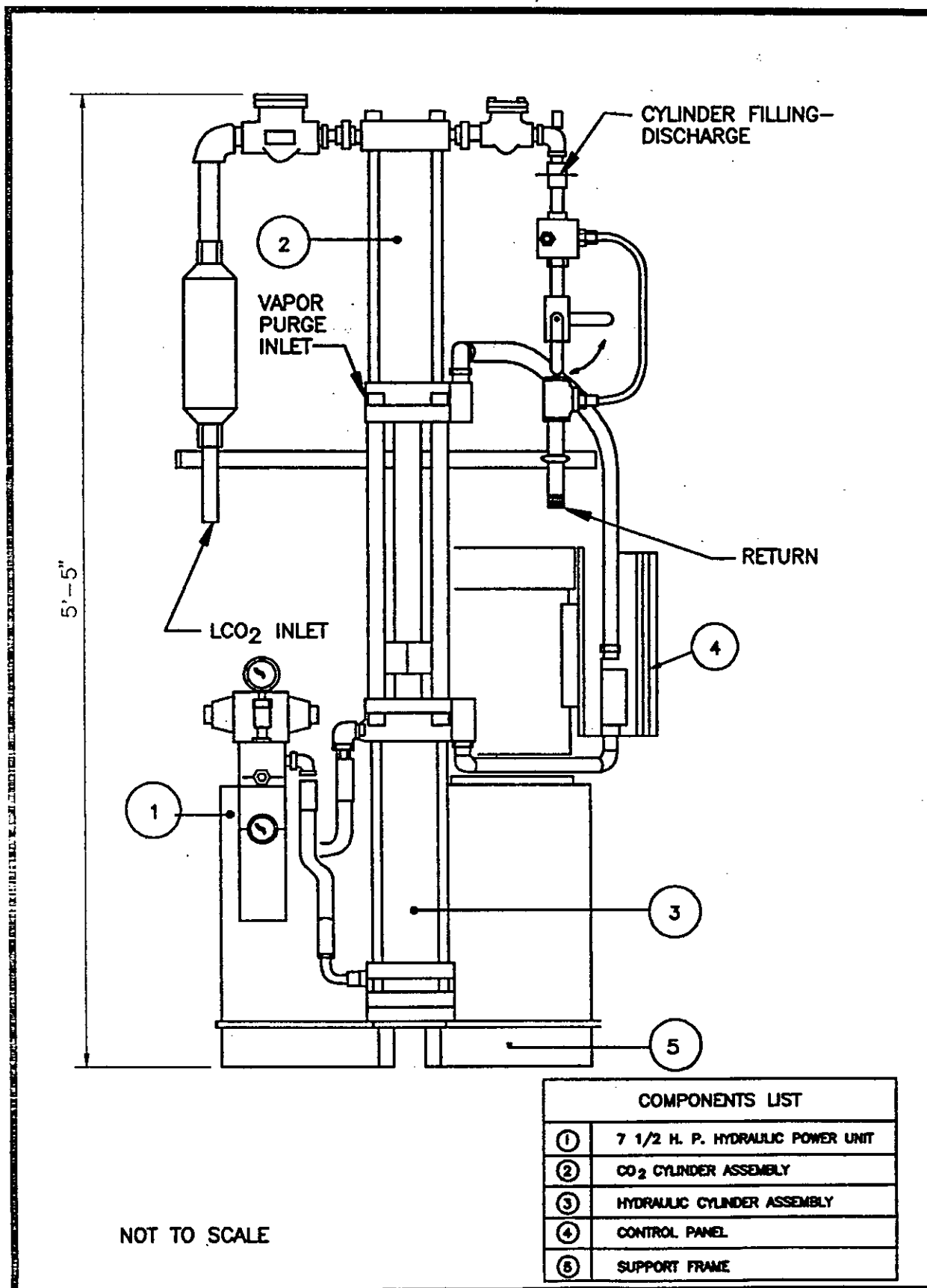
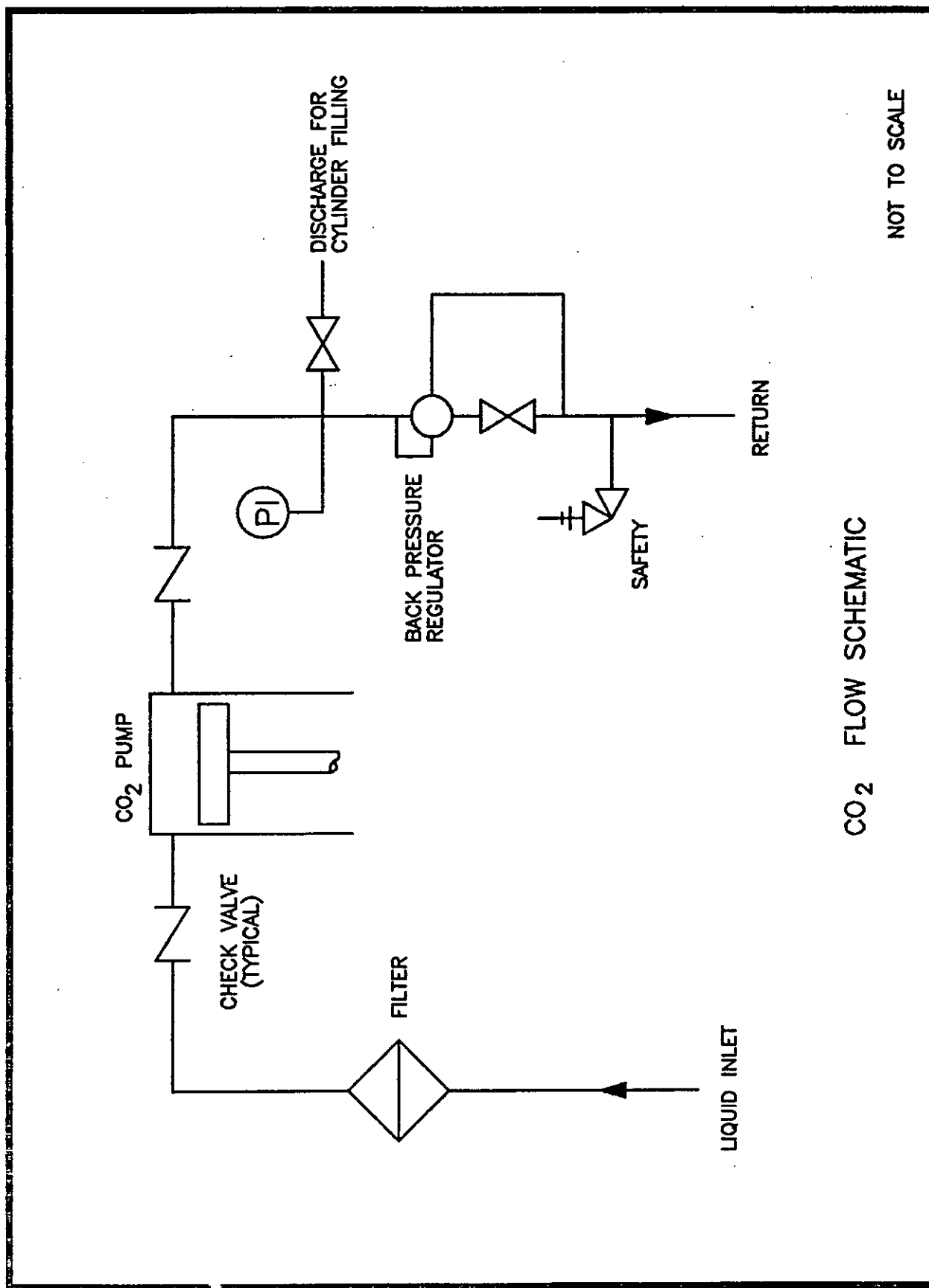

Figure I-4
21C12/21C12A CO₂ Manual Extinguisher Fill Pump



CO₂ FLOW SCHEMATIC

NOT TO SCALE

Figure I-5
21C12/21C12A CO₂ Flow Schematic

MIL-HDBK-1027/1

208-230-460V.,30,60HZ

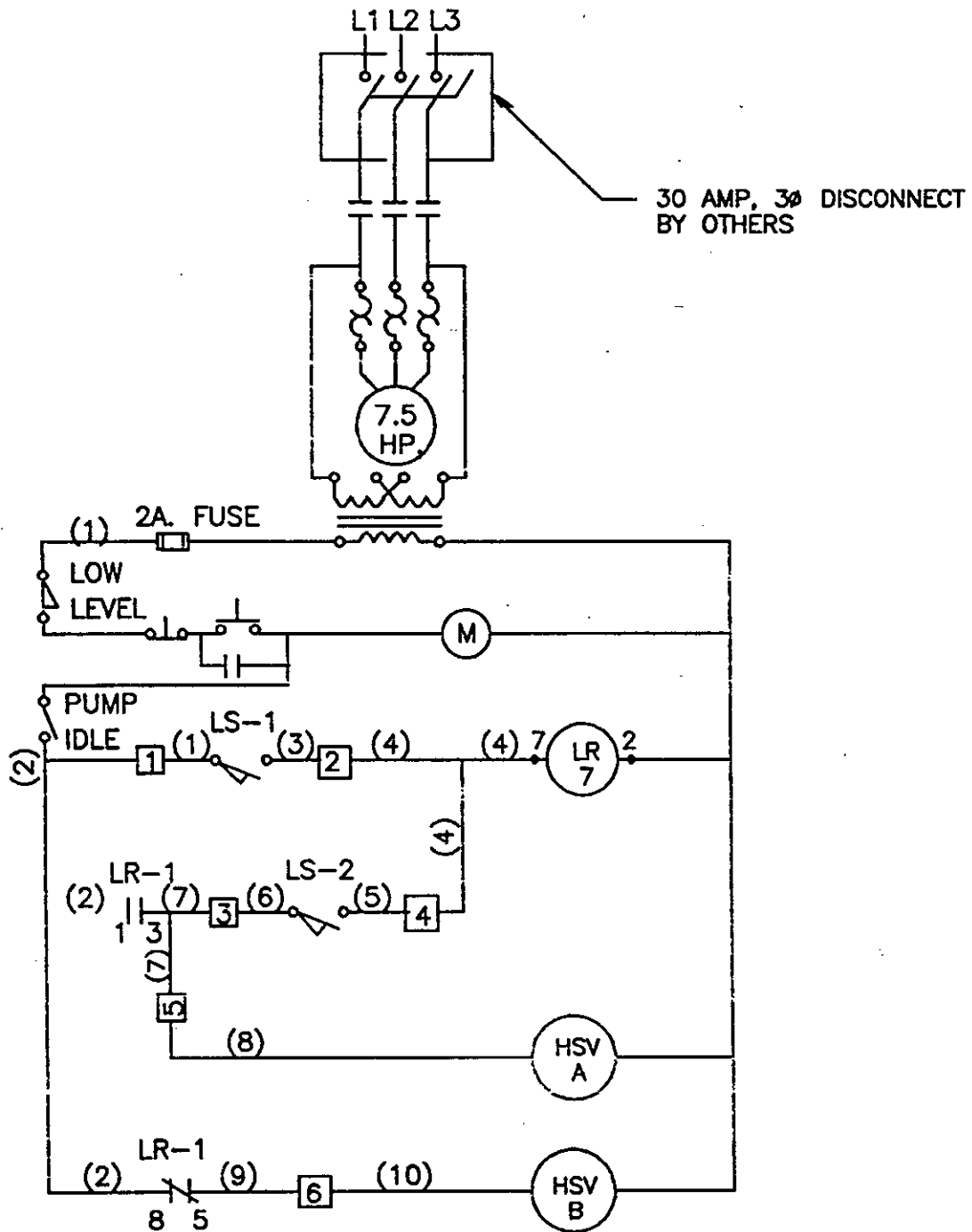

Figure I-6
21C12/21C12A CO₂ Wiring Schematic

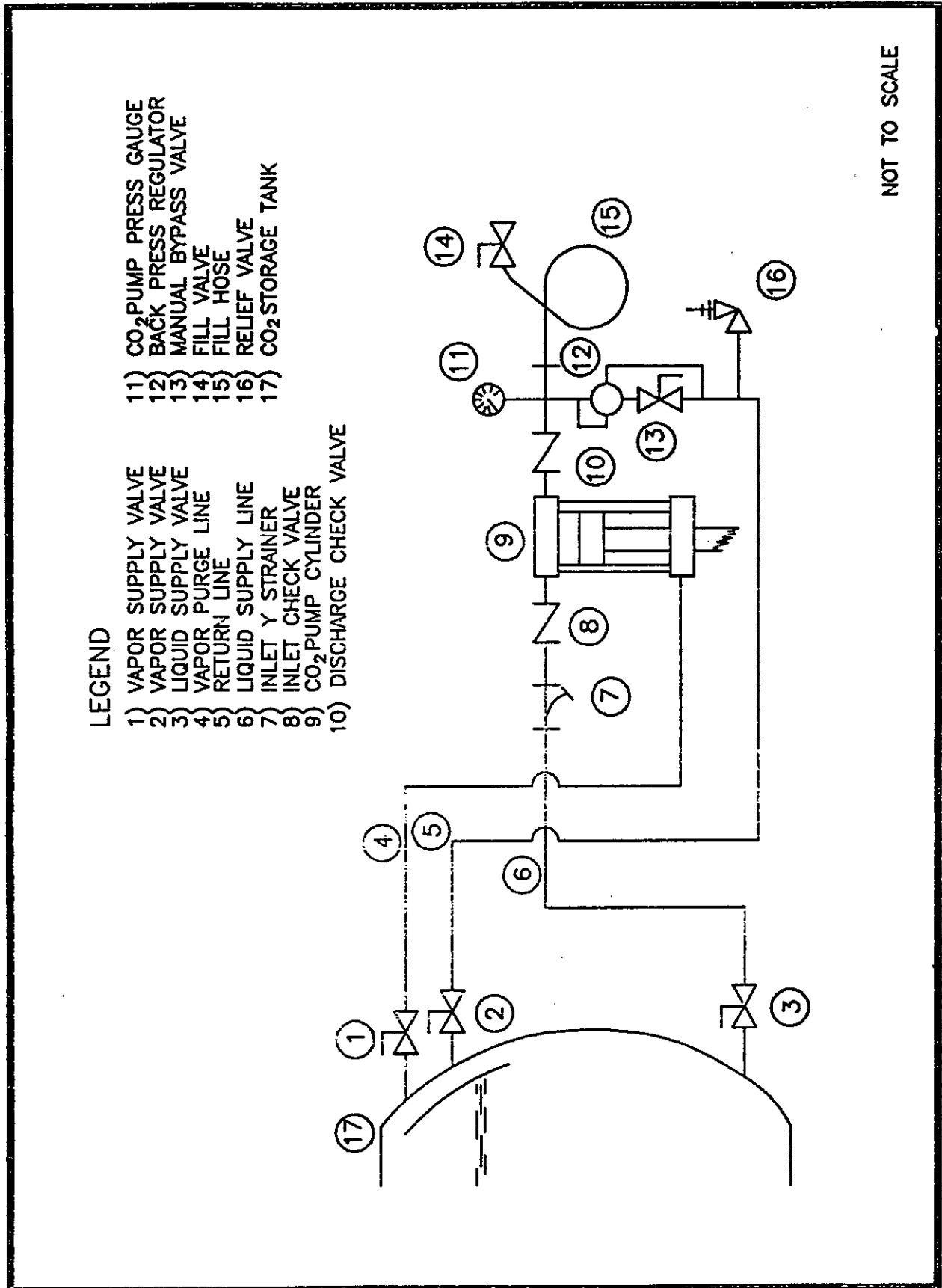

Figure I-7
21C12/21C12A CO₂ Legend

MIL-HDBK-1027/1

APPENDIX J
PROPANE

Clearance Requirements	J-1A-B
Propane Gas Train at Facility/Device Interface	J-2
Symbol Interpretation/Identification	J-3
Waterbath Vaporizer With Liquid Pump	J-4A-B
Steam Heated Vaporizer With Liquid Pump	J-5A-B
Waterbath Vaporizer Without Liquid Pump	J-6A-B
Steam Heated Vaporizer Without Liquid Pump	J-7A-B

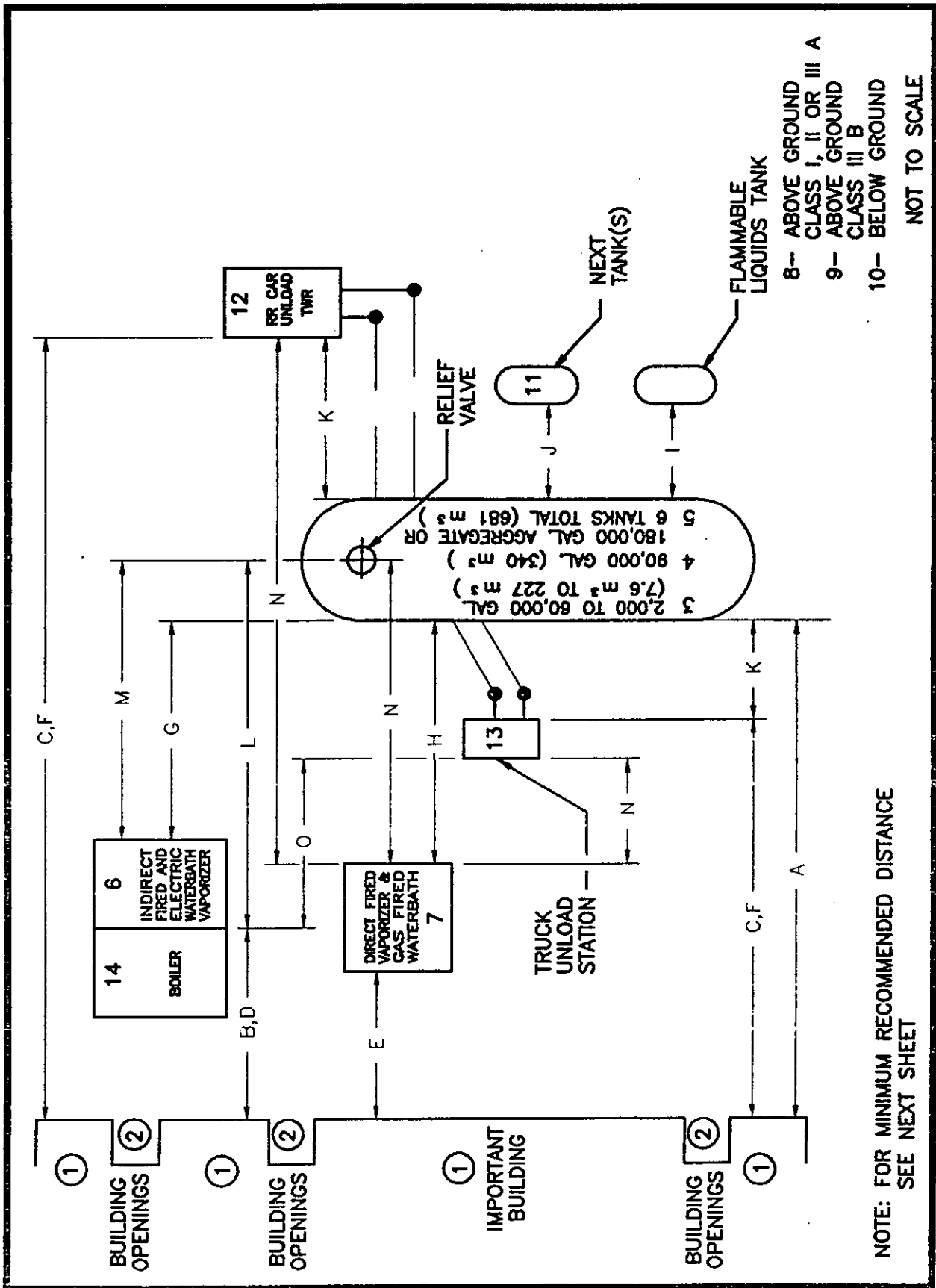

Figure J-1A
Clearance Requirements

MIL-HDBK-1027/1

MINIMUM RECOMMENDED DISTANCE			
DIMENSION	POINT TO POINT	DISTANCE, ft.	DISTANCE, m.
A	1 to 3 ^a	75	23
	4 ^a	150	46
	5 ^b	200	60
	5 ^c	350	105
	6	20	6
B C	12	200	60
	13	50	15
D E F	2 to 6	20	6
	7	50	15
G H I	12	200	60
	13	75	23
J K	3,4,5 to 6	5	1.5
	7	15	4.5
L M N O	8	100	30
	9	50	15
J K	10	20	6
	11 ^d	75	23
L M N O	12	75	23
	13	50	15
L M N O	14	75	23
	6 to 15	50	15
L M N O	7 to 12,13,15 ^e	75	23
	13 to 14	75	23

NOTES:

- a. FOR SINGLE TANKS ONLY. TREAT MULTIPLE TANKS AS NO. 5
- b. FOR BUILDINGS WITH HYDRANT PROTECTION.
- c. FOR BUILDINGS WITHOUT HYDRANT PROTECTION.
- d. 5 ft. (1.5 m.) FOR TANKS WITHIN A GROUP.
- e. FOR TANKS SMALLER THAN 2,000 GAL. (7.6 m³), 25 ft. (7.6 m).

Figure J-1B
Clearance Requirements

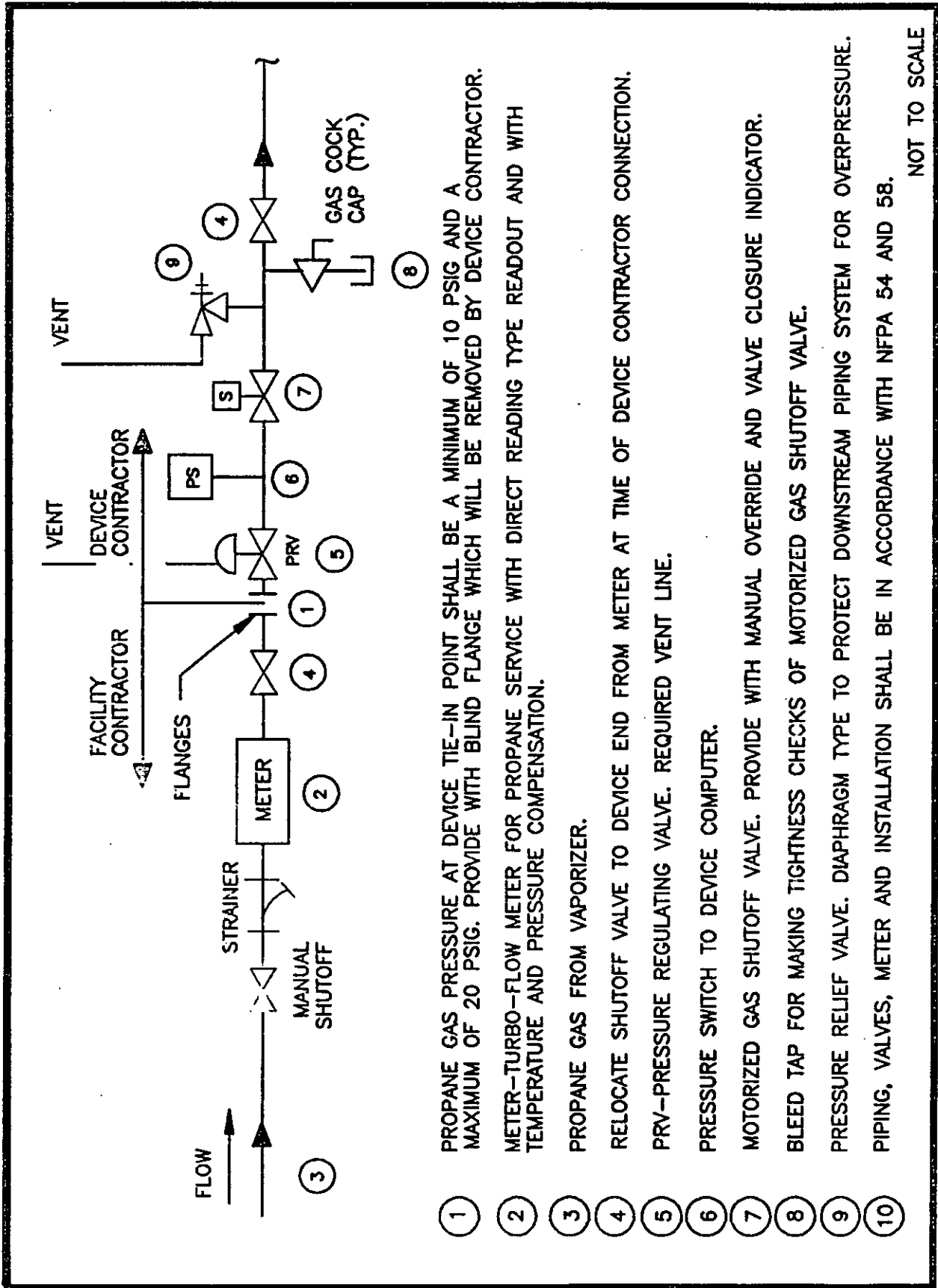

Figure J-2
Propane Gas Train at Facility/Device Interface

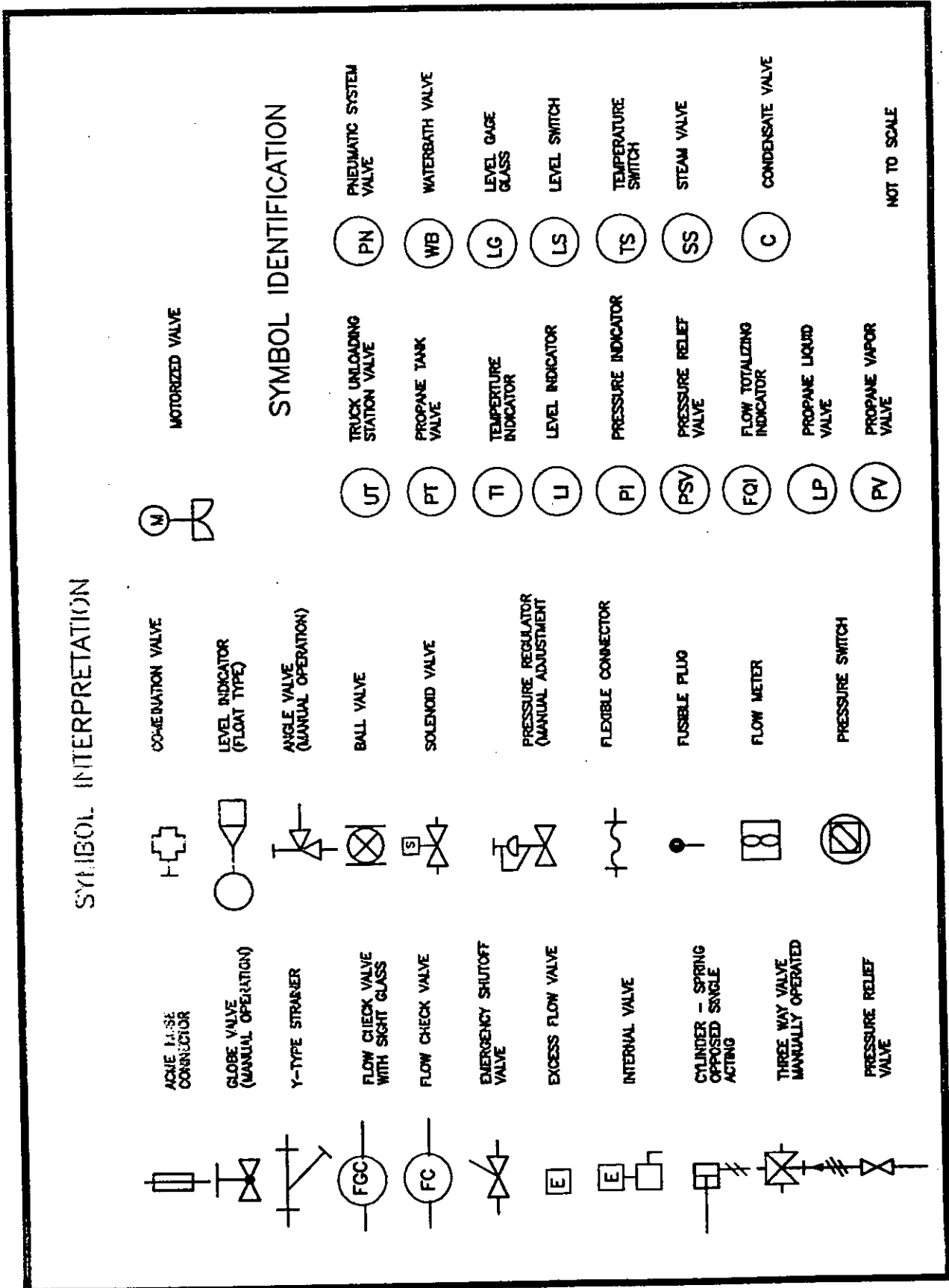

Figure J-3
Symbol Interpretation/Identification

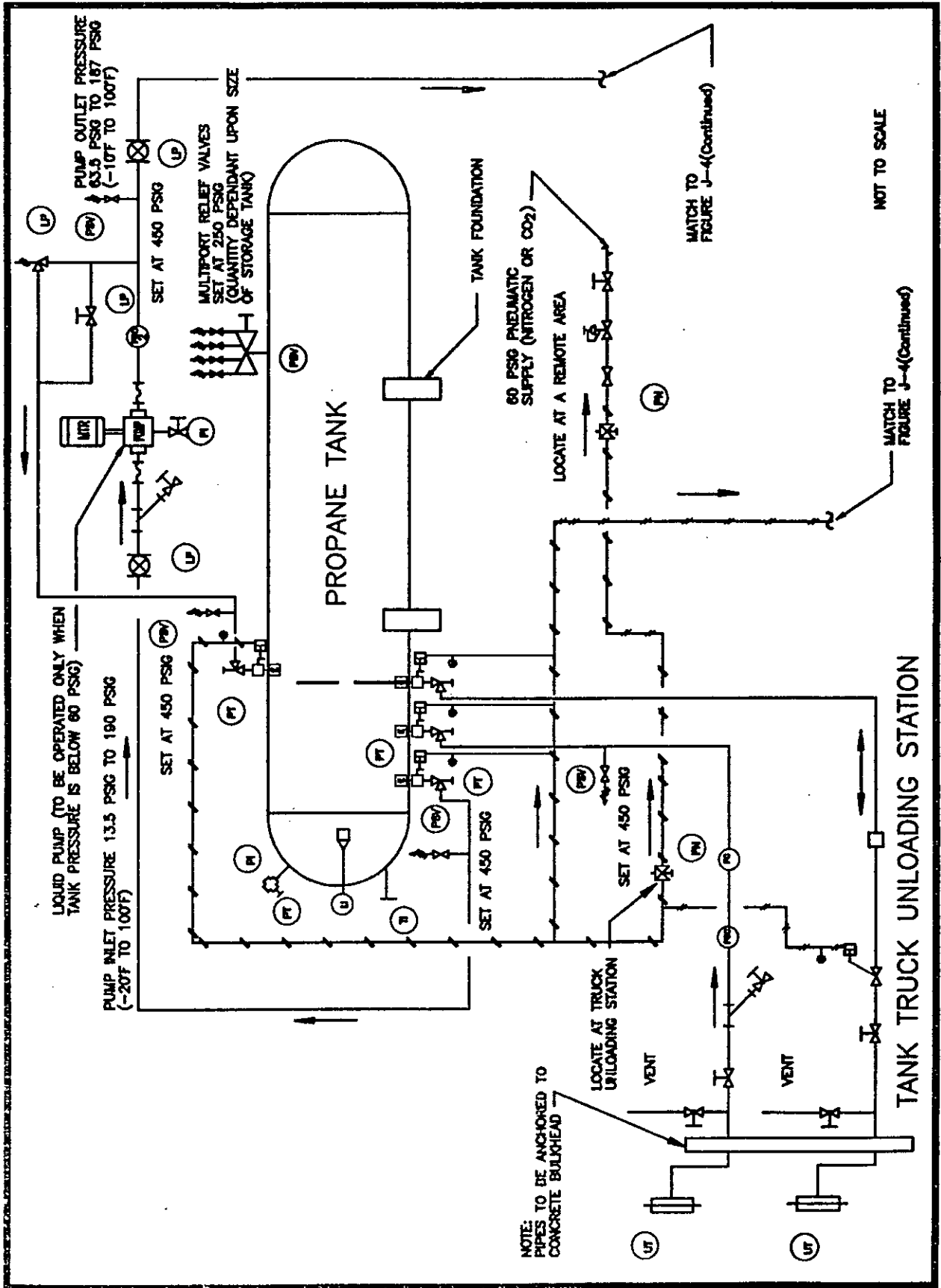

Figure J-4A
Waterbath Vaporizer with Liquid Pump

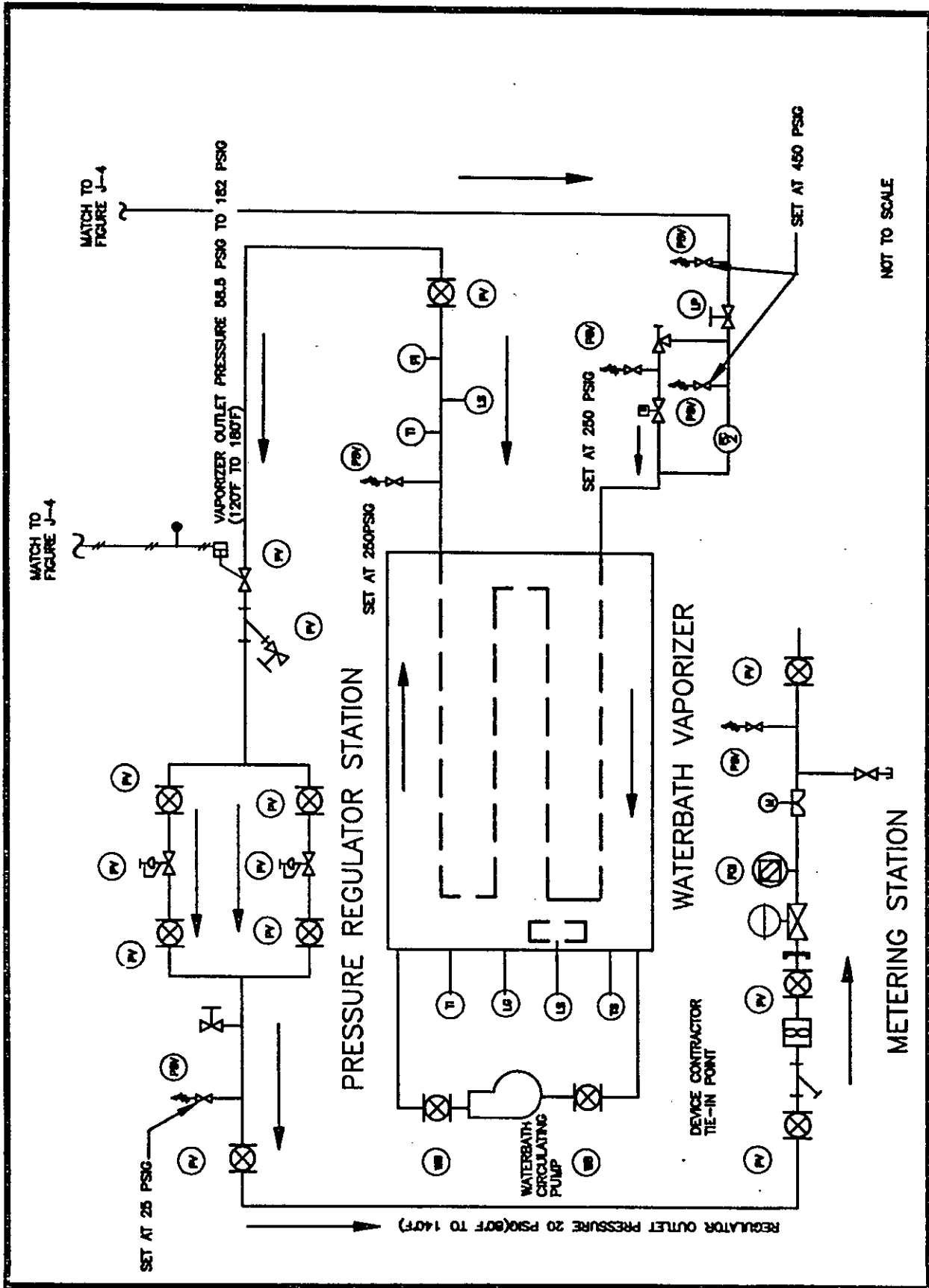

Figure J-4B
Waterbath Vaporizer with Liquid Pump

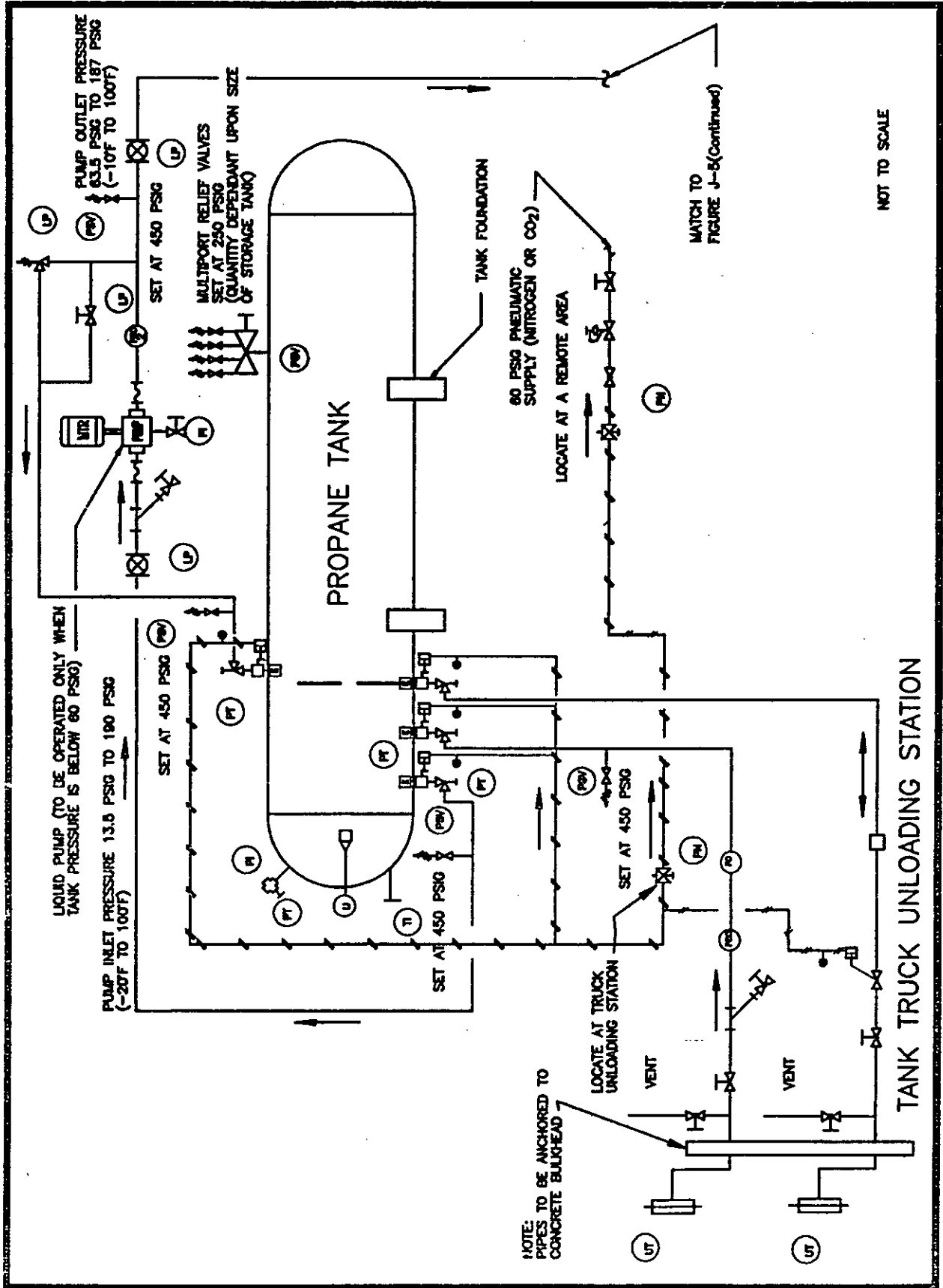

Figure J-5A
Steam Heated Vaporizer with Liquid Pump

MIL-HDBK-1027/1

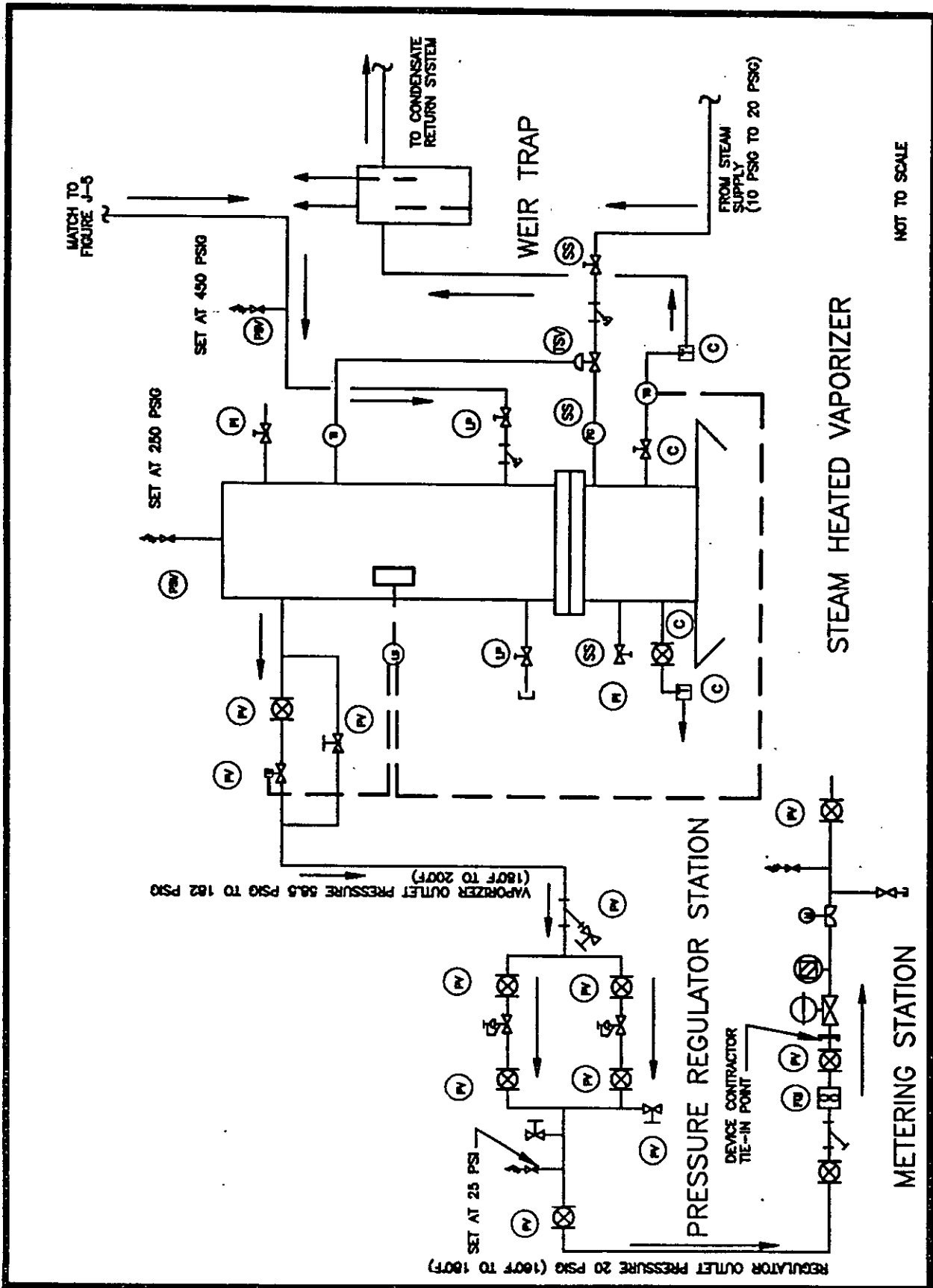

Figure J-5B
Steam Heated Vaporizer with Liquid Pump

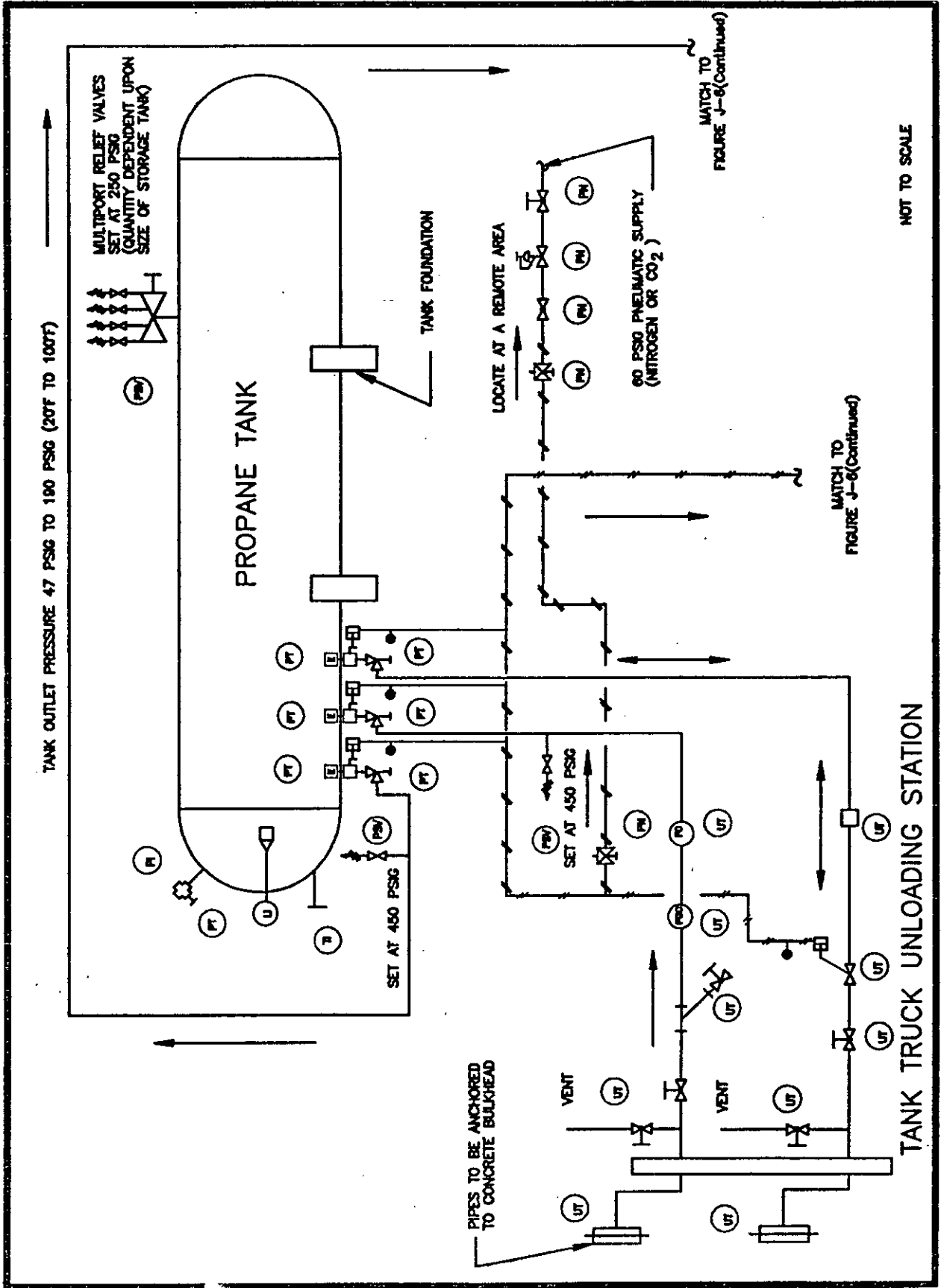

Figure J-6A
Waterbath Vaporizer without Liquid Pump

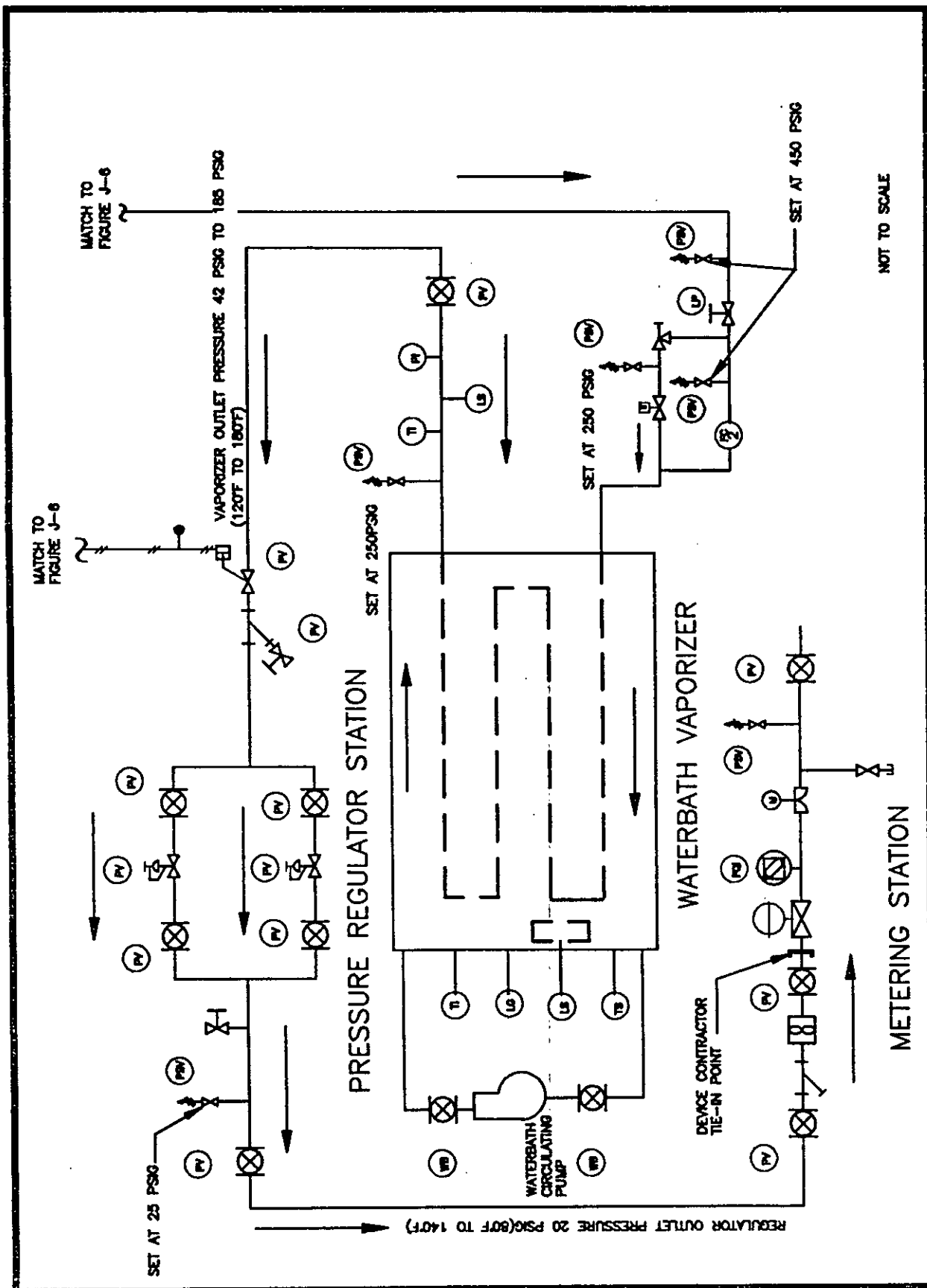

Figure J-6B
Waterbath Vaporizer without Liquid Pump

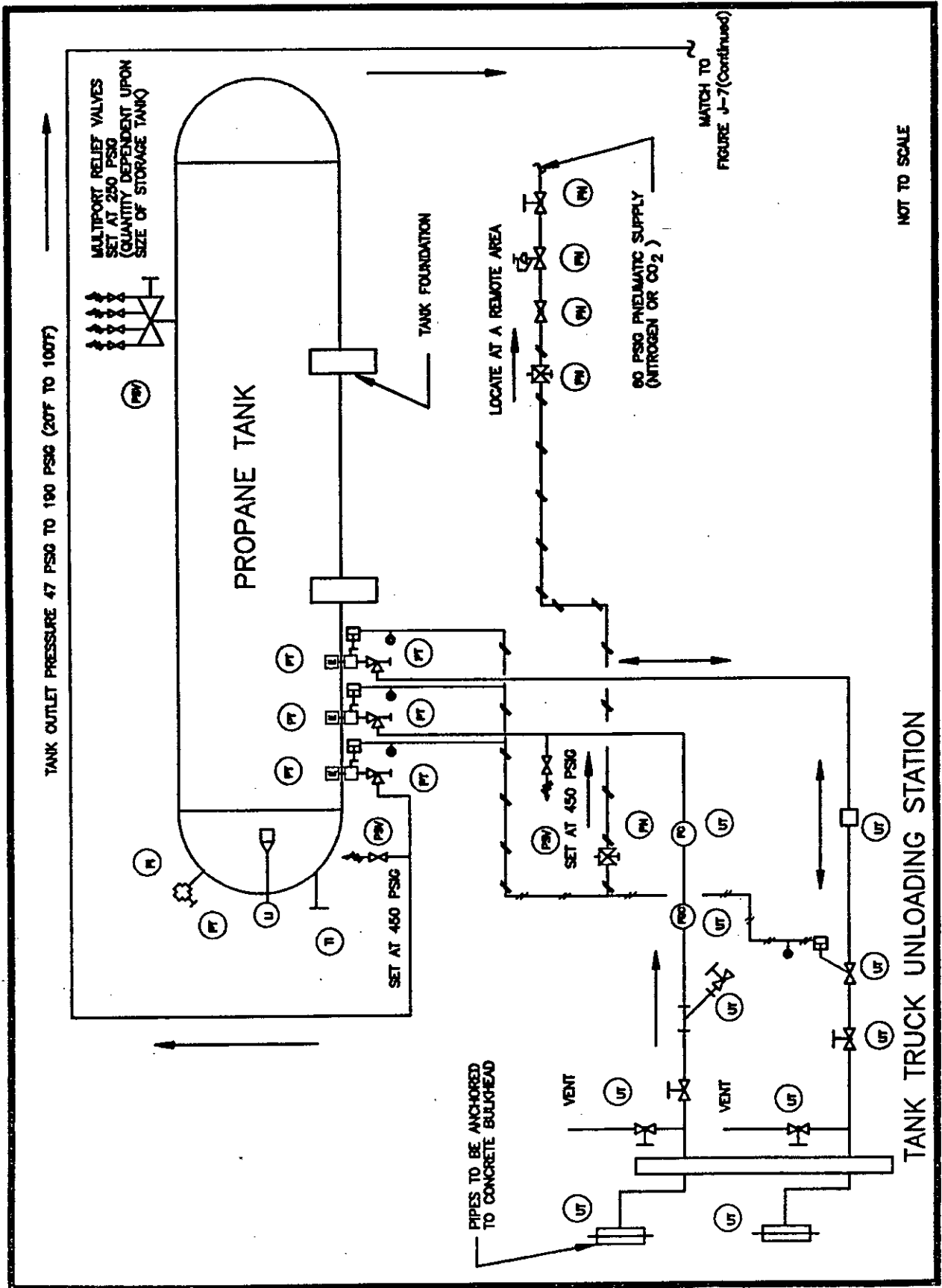

Figure J-7A
Steam Heated Vaporizer without Liquid Pump

MIL-HDBK-1027/1

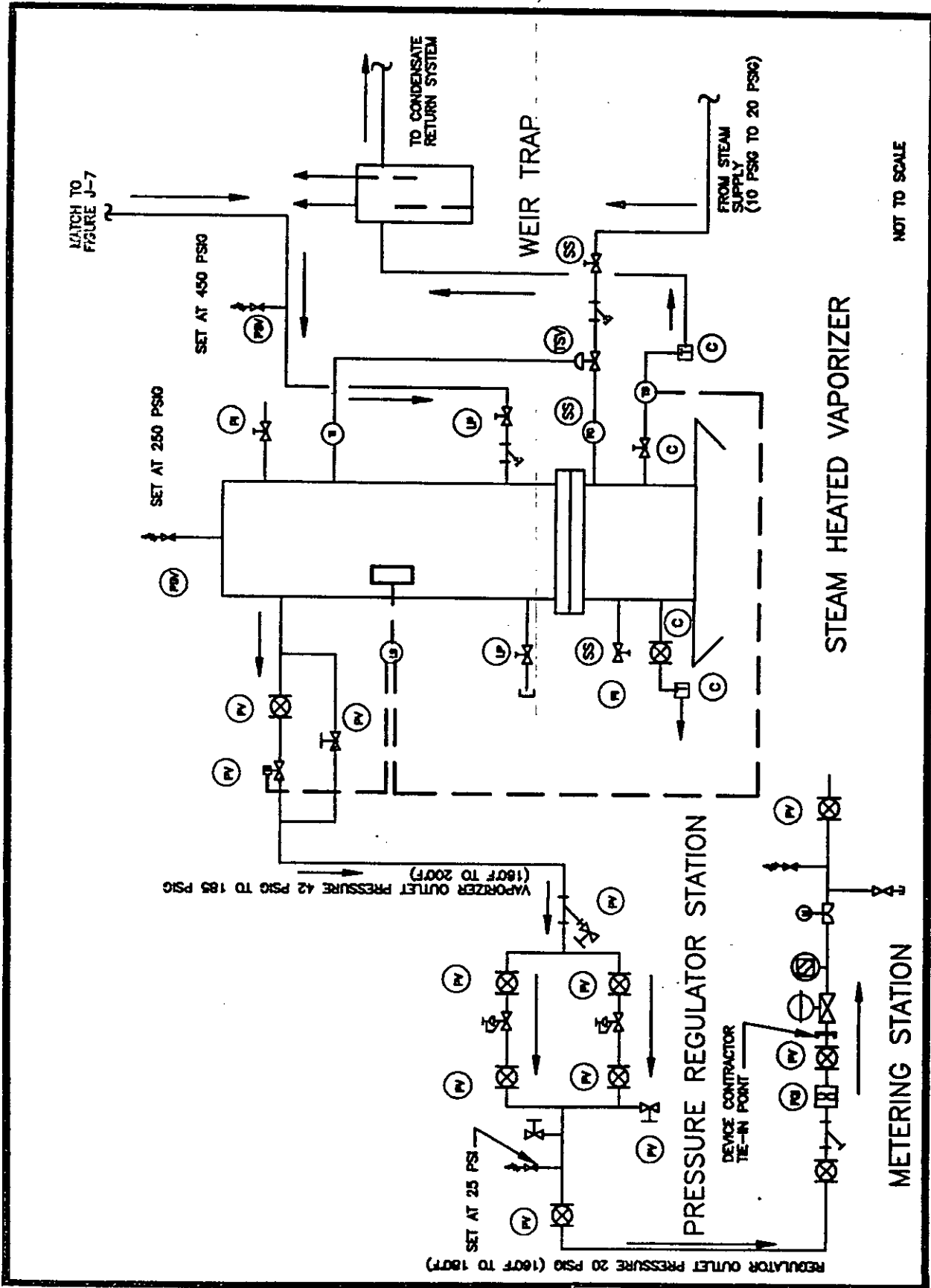

Figure J-7B
Steam Heated Vaporizer without Liquid Pump

MIL-HDBK-1027/1

REFERENCES

NOTE: The following referenced documents form a part of this handbook to the extent specified herein. Unless otherwise specified in the text, users of this handbook should utilize the latest revisions of the documents cited herein.

FEDERAL/MILITARY SPECIFICATIONS, STANDARDS, BULLETINS, HANDBOOKS, AND NAVFAC GUIDE SPECIFICATIONS:

Unless otherwise indicated, copies are available from the Naval Publishing and Printing Service Office (NPPSO), Document Order Desk, Building 4D, 700 Robbins Avenue, Philadelphia, PA 19111-5094.

FEDERAL SPECIFICATIONS

BB-A-1034B	Compressed Air, Breathing
ZZ-H-451G	Hose, Fire, Woven-Jacketed Rubber or Latex or Rubber-Coated Fabric-Lined with Couplings

MILITARY SPECIFICATIONS

MIL-E-24091	Extinguisher, Fire, Portable, Potassium Bicarbonate, Dry Chemical, Cartridge-Operated Type
MIL-E-24269	Extinguisher, Fire, Carbon Dioxide, 15 lb, Portable, Permanent-Shutoff, Navy Shipboard Use
MIL-N-24408B(1)	Nozzle Fire Hose, Combination Aqueous Film Forming Foam, Water Spray, Adjustable Pattern (Shipboard Use)
MIL-R-24414C	Reels and Guides, Hose, Firefighting Manually Operated
MIL-H-24580(2)	Hose Assemblies, Synthetic Rubber, Noncollapsible, Firefighting
MIL-H-24606A	Hose Assemblies, Chlorosulfonated Polyethylene Impregnated, Double Synthetic Jacket, With Couplings, Firefighting and Other Water Service
MS 24679	Nut, Plain, Cap, Low Crown, UNC-2B and UNF-2B
MIL-W-25038E(1)	Wire, Electrical, High Temperature and Fire Resistant
MIL-F-29046(2)	Flooring Raised, General Specification for

MIL-HDBK-1027/1

NAVFAC GUIDE SPECIFICATIONS

NFGS-15403 Nonflammable Medical Gas Systems

HANDBOOKS

MIL-HDBK-1012/1 Electronics Facilities Engineering

NAVY MANUALS, P-PUBLICATIONS, AND MAINTENANCE OPERATING MANUALS:

OPNAVINST 5090.1 Environmental and Natural Resources Protection Manual, Chapter 6, Air Pollution Abatement

NAVSHIPS Technical Manual Chapter 9930

DM-22 Petroleum Fuel Facilities

P-307 Management of Weight Handling Equipment Management of Certification

NAVMAT P-9290 System Certification Procedures Criteria Manual for Deep Submergency System

Available from Naval Publications and Forms Center, 5801 Tabor Avenue, Philadelphia, PA 19120-5099; private organizations must write to NPFC, ATTENTION: Cash Sales, Code 1051, 5801 Tabor Avenue, Philadelphia, PA 19120-5099.

OTHER GOVERNMENT DOCUMENTS AND PUBLICATIONS:

DEPARTMENT OF LABOR

29 CFR 1910 OSHA Safety and Health Standards for General
(Labor OSHA Industry
Reg. 2206)

Unless otherwise indicated, copies are available from Occupational Safety and Health Administration, 200 Constitution Avenue NW, Washington DC 20210.

DRAWINGS

BUREAU OF SHIPS (BUSHIPS)

23-2146601 W.T. Door - 20" x 38" INT General ARR

23-2146602 W.T. Door - INT Door Frame Det.

23-2146603 W.T. Door - INT Door Det.

MIL-HDBK-1027/1

23-2146604	W.T. Door - INT Gear Det.
23-2146605	W.T. Door - INT Latch Det.
23-2146606	W.T. Door - INT Stop Det.
23-2146607	W.T. Door - INT Fixed Deadlight
23-2146608	W.T. Door - INT Latch Det. & Assy R.C. Holding
804-5184163	Trunk Safety Nets
805-1400064	WTQA Doors - 18"x36", 6 Dog Arrangement
805-1624089	Hatch W.T. Raised Individually Dogged 36" x 60" with Scuttle-15 P.S.I. Arrangement
805-1624122	Hatch W.T. Raised Quick Acting 36" x 42-5 P.S.I. Arrangement
810-1385834	Water Fog 1-1/2-inch Ball Type

Available from Naval Engineering Drawing Support Activity, Portsmouth, NH
03804-5000.

NAVAL SEA SYSTEMS COMMAND (NAVSEA)

608-4674414	Mounting Fire Hose Rack and Access
804-860089	Rack Hose Assembly Detail

NAVSHIPS

803-1385711	Valve, Hose Globe & Angle
803-5184129	Steel Balanced Door
804-1749235	Thermally Insulated Ladder Rungs for Escape Trunks From Machinery Spaces
805-1400066	Doors W.T. (Individually Dogged) Medium Steel
805-1400074	Galvanized Steel, Without HASP Assembly
805-9-1749017	Metal Joiner Door Balanced Type Assembly

MIL-HDBK-1027/1

805-0-1749018	Metal Joiner Door Balanced Type Hardware Layout
805-9-1749019 through 1749021	Metal Joiner Door Balanced Type Hardware Detail
805-1749113	Inclined Ladders Aluminum Assemblies
805-860089	Metal Hose Rack Assembly & Details
810-1385901	Strainer & Valve Connection
810-4444647	Syringe Spanner Navy Fire Hose

Available from Naval Engineering Drawing Support Activity, Portsmouth, NH
033804-5000.

MARE ISLAND

612-1889964A1	Emergency Air Breathing Device
612-1889964A2	Emergency Air Breathing Device Models

Available from Naval Engineering Drawing Support Activity, Portsmouth,
NH 033804-5000.

NON-GOVERNMENT PUBLICATIONS:

AMERICAN CONFERENCE OF GOVERNMENTAL INDUSTRIAL HYGIENISTS (ACGIH)

Industrial Ventilation Guide

ACGIH 2080	Industrial Ventilation, A Manual of Recommended Practice
------------	---

Available from the American Conference of Governmental Industrial Hygienists
(ACGIH), 6500 Glenway Avenue, Bldg. D-7, Cincinnati, OH 45211-4438.

AMERICAN NATIONAL STANDARDS INSTITUTE (ANSI)

ANSI-Z358.1	Eyewash Shower Equipment, Emergency
ANSI B31.3	Chemical Plant and Petroleum Refinery Piping

Unless otherwise indicated, copies are available from American National
Standards Institute, 1430 Broadway, New York, NY 10018.

MIL-HDBK-1027/1

AMERICAN PETROLEUM INSTITUTE (API)

API 2510 Design and Construction of LP Gas Installations at
Marine and Pipeline Terminals, Natural Gas
Processing Plants, Refineries, Petrochemical
Plants, and Tank Farms,

Available from the American Petroleum Institute, 1220 L Street NW, Washington,
DC 20005.

AMERICAN SOCIETY FOR TESTING AND MATERIALS (ASTM)

ASTM A36 Structural Steel

Available from American Society for Testing and Materials, 1916 Race Street,
Philadelphia, PA 19103.

AMERICAN SOCIETY OF MECHANICAL ENGINEERS (ASME)

Boiler and Pressure Vessel Code

Available from American Society of Mechanical Engineers (ASME), 345 East 47th
Street, New York, NY 10017.

AMERICAN WATER WORKS ASSOCIATION (AWWA)

AWWA C506 Backflow Prevention Devices--Reduced Principle and
Doublecheck Valve Types

Available from American Water Works Association, 6666 West Quincy Avenue,
Denver, CO 80235, Telephone (303) 794-7711.)

FACTORY MUTUAL RESEARCH CORPORATION (FM)

Loss Prevention Data

Available from Factory Mutual Research Corporation (FM), 1151 Boston-Providence
Turnpike, P.O. Box 9102, Norwood, MA 02062.

NATIONAL FIRE PROTECTION ASSOCIATION (NFPA)

NFPA 12 Carbon Dioxide Extinguishing Systems,

NFPA 24 Installation of Private Fire Service Mains and
Their Appurtenances

NFPA 54 National Fuel Gas Code

MIL-HDBK-1027/1

NFPA 58	Storage and Handling of Liquefied Petroleum Gasses
NFPA 70	National Electrical Code
NFPA 78	Lightning Protection Code

Unless otherwise indicated copies are available from National Fire Protection Association, Batterymarch Park, Quincy, MA 02269-9904.

UNDERWRITERS LABORATORIES INC.

UL 844	Electric Lighting Fixtures for Use in Hazardous (Classified) Locations
UL 595	Marine-Type Electric Lighting Fixtures

Available from Underwriters Laboratories Inc., 333 Pfingsten Road, Northbrook, IL 60062.

CUSTODIAN
NAVY - YD

PREPARING ACTIVITY
NAVY - YD

PROJECT NO.
FACR-0224

*U.S. GOVERNMENT PRINTING OFFICE: 1991--504-034/50331

STANDARDIZATION DOCUMENT IMPROVEMENT PROPOSAL

INSTRUCTIONS

1. The preparing activity must complete blocks 1, 2, 3, and 8. In block 1, both the document number and revision letter should be given.
2. The submitter of this form must complete blocks 4, 5, 6, and 7.
3. The preparing activity must provide a reply within 30 days from receipt of the form.

NOTE: This form may not be used to request copies of documents, nor to request waivers, or clarification of requirements on current contracts. Comments submitted on this form do not constitute or imply authorization to waive any portion of the referenced document(s) or to amend contractual requirements.

I RECOMMEND A CHANGE:		1. DOCUMENT NUMBER MIL-HDBK-1027/1	2. DOCUMENT DATE (YYMMDD) 91/03/15
3. DOCUMENT TITLE FIREFIGHTING SCHOOL FACILITIES			
4. NATURE OF CHANGE (Identify paragraph number and include proposed rewrite, if possible. Attach extra sheets as needed.)			
5. REASON FOR RECOMMENDATION			
6. SUBMITTER			
a. NAME (Last, First, Middle, Initial)		b. ORGANIZATION	
c. ADDRESS (Include Zip Code)		d. TELEPHONE (Include Area Code) (1) Commercial (2) AUTOVON (If applicable)	7. DATE SUBMITTED (YYMMDD)
8. PREPARING ACTIVITY			
a. NAME Naval Facilities Engineering Command Atlantic Division		b. TELEPHONE (Include Area Code) (1) Commercial (2) AUTOVON (804) 444-9970	
c. ADDRESS (Include Zip Code) Code 04A4 Norfolk, VA 23511-6287		IF YOU DO NOT RECEIVE A REPLY WITHIN 45 DAYS, CONTACT: Defense Quality and Standardization Office 5203 Leesburg Pike, Suite 1403, Falls Church, VA 22041-3466 Telephone (703) 756-2340 AUTOVON 289-2340	