

NOTICE OF CHANGE

MIL-HDBK-1003/8A
 NOTICE 1
 30 AUGUST 1991

MILITARY HANDBOOK

EXTERIOR DISTRIBUTION OF STEAM, HIGH TEMPERATURE WATER,
 CHILLED WATER, NATURAL GAS, AND COMPRESSED AIR

TO ALL HOLDERS OF MIL-HDBK-1003/8A:

1. THE FOLLOWING PAGES OF MIL-HDBK-1003/8A HAVE BEEN REVISED AND SUPERSEDED THE PAGES LISTED:

NEW PAGE	DATE	SUPERSEDED PAGE	DATE
63	30 August 1991	63	REPRINTED WITHOUT CHANGE
64	30 August 1991	64	30 August 1991

2. RETAIN THIS NOTICE AND INSERT BEFORE TABLE OF CONTENTS.

3. Holders of MIL-HDBK-1003/8A will verify that all changes indicated above have been made. This notice page will be retained as a check sheet. This issuance, together with appended pages, is a separate publication. Each notice is to be retained by stocking points until the military handbook is completely revised or canceled.

CUSTODIAN:
 NAVY-YD

PREPARING ACTIVITY:
 NAVY-YD

PROJECT NO.
 FACR-1061

AMSC N/A

AREA FACR

DISTRIBUTION STATEMENT A. APPROVED FOR PUBLIC RELEASE: DISTRIBUTION
 UNLIMITED

MIL-HDBK-1003/8A
 CHANGE 1, 30 AUGUST 1991

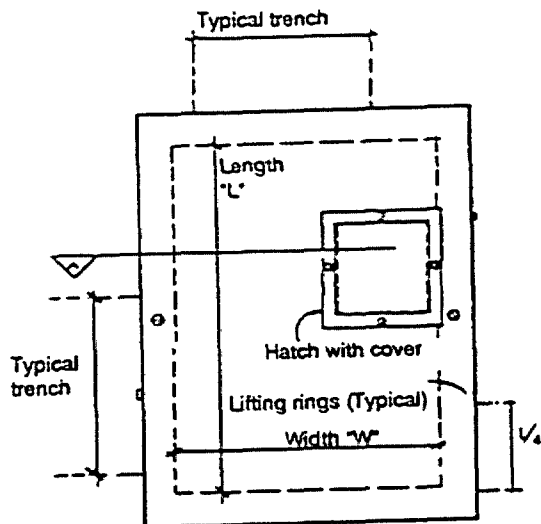

TYPICAL STANDARD VALVE MANHOLE COVER

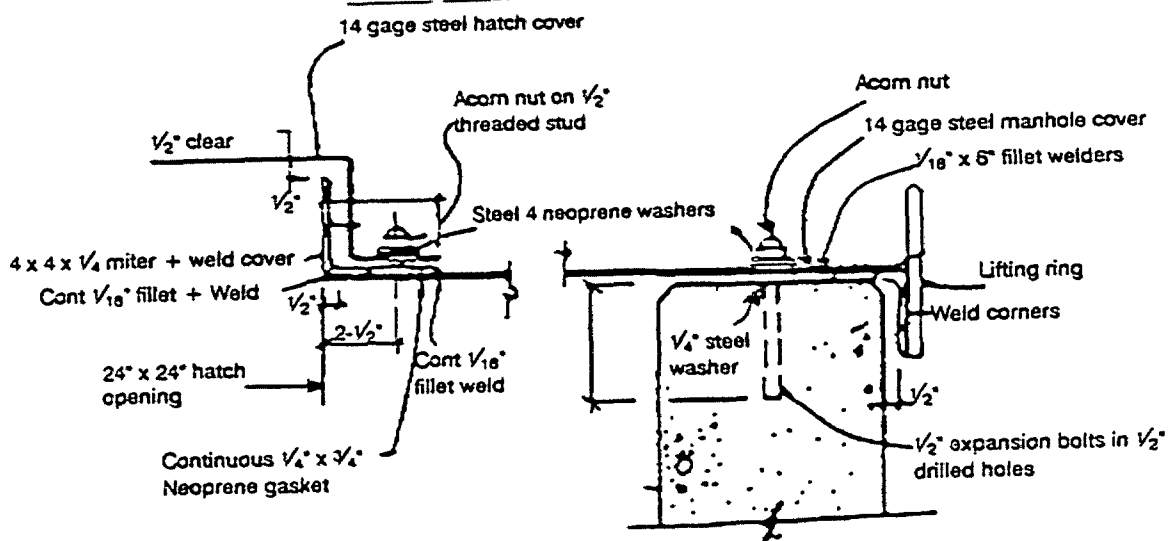

SECTION A

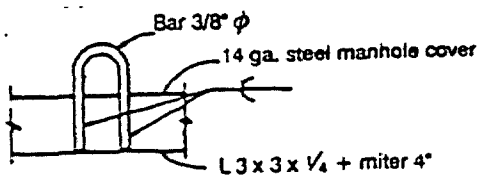

SECTION D

TYPICAL LIFTING RING

Figure 23
 Concrete Shallow Trench Heat Distribution System
 Detail 12

MIL-HDBK-1003/8A
CHANGE 1, 30 AUGUST 1991

NOTE: THE CONTRACTOR SHALL DESIGN ITEMS INDICATED BY DASHED LINES.

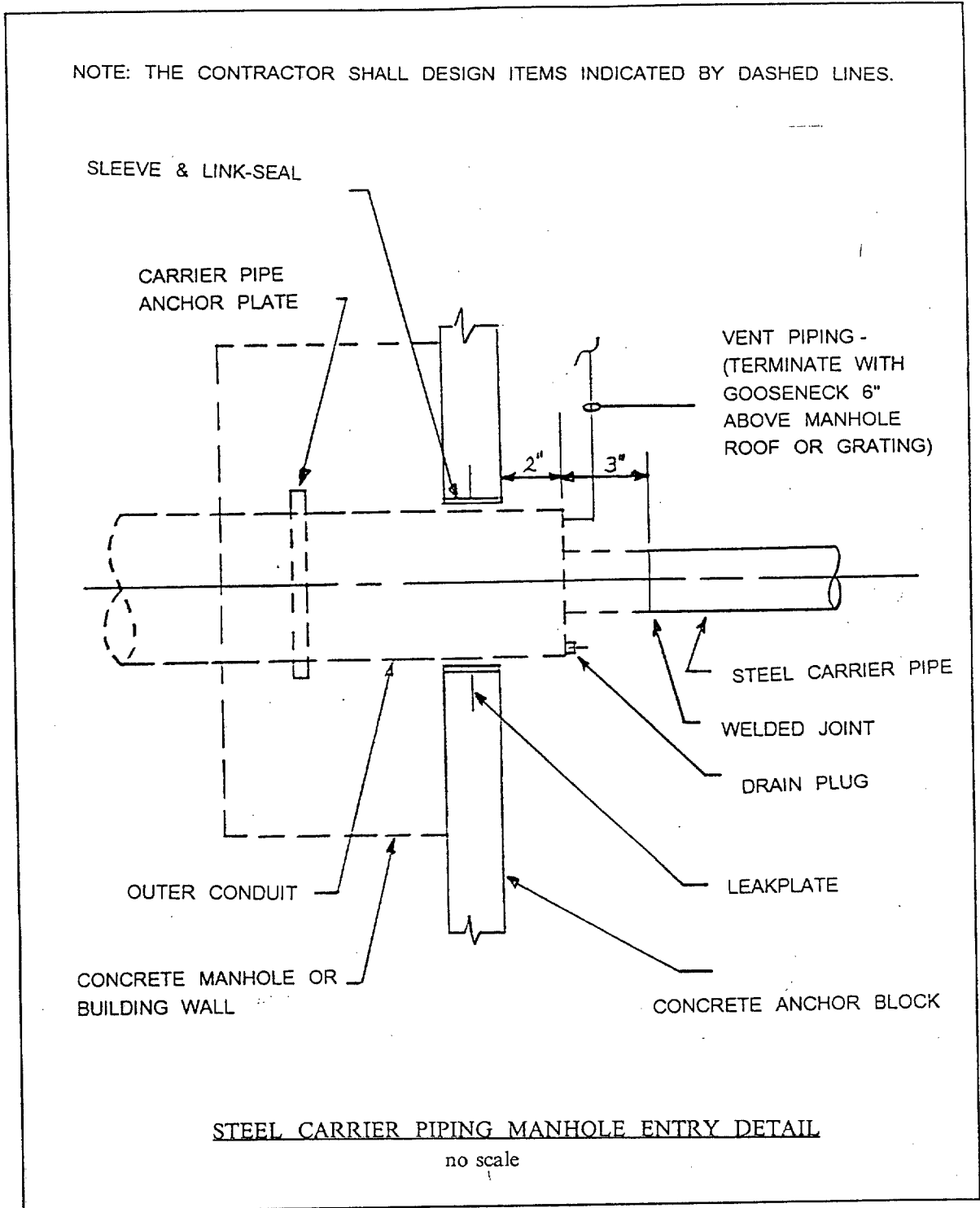

Figure 24
Steel Carrier Piping Manhole Entry Detail
(no scale)