

MIL-HDBK-759B

METRIC

MIL-HDBK-759B (MI)
30 JUNE 1992
SUPERSEDING
MIL-HDBK-759A
30 June 1981

MILITARY HANDBOOK

**HUMAN FACTORS ENGINEERING
DESIGN FOR ARMY MATERIEL
METRIC**



AMSC/NA

AREA HFAC

DISTRIBUTION STATEMENT A. Approved for public release; distribution is unlimited.

MIL-HDBK-759B

FOREWORD

1. This military handbook is approved for use by the US Army Missile Command (MICOM), the Department of Defense and is available for use by all departments and agencies of the Department of Defense.

2. Beneficial comments (recommendations, additions, deletions) and any pertinent data which may be of use in improving this document should be addressed to: Commander, US Army Missile Command, AMSMI-RD-SE-TD-ST, Redstone Arsenal, Alabama 35898-5270, by using the Standardization Document Improvement Proposal (DD Form 1426) appearing at the end of this document or by letter.

3. This handbook was developed by the US Army Human Engineering Laboratory's MICOM Detachment, acting as agent for the preparing activity, the US Army Missile Command.

4. This document provides basic guidelines and data on human factors engineering design for Army materiel. This handbook is not intended to be referenced in its entirety for mandatory use by procurement specifications. Specific information may be referenced.

MIL-HDBK-759B

CONTENTS

<u>PARAGRAPH</u>	<u>Page</u>
1.	SCOPE1
1.1	Scope.....1
1.2	Applicability.....1
1.2.1	Application1
1.2.2	Selection of hardware, materials or processes 1
1.2.3	Gender considerations1
1.2.4	Manufacturing tolerances..... 1
2.	APPLICABLE DOCUMENTS..... 3
2.1	Government documents 3
2.1.1	Specifications, standards and handbooks..... 3
2.1.2	Other government documents, drawings, and publications.....7
2.2	Non-government publications8
2.3	Order of precedence 9
3.	DEFINITIONS11
4.	GENERAL GUIDELINES 17
4.1	Objectives 17
4.2	Human performance 17
4.3	Standardization 18
4.4	Equipment selection..... 18
4.5	Function allocation 18
4.6	Fail-safe design 18
4.7	Simplicity of design 19
4.8	Interaction 19
4.9	Safety 19
4.10	Ruggedness..... 19
4.11	Design for NBC survivability 19
4.12	Design for electromagnetic pulse (EMP) hardening 19
5.	DETAILED GUIDELINES 21
5.1	General..... 21
5.2	Controls, displays and consoles 21
5.2.1	Controls 21
5.2.1.1	General criteria..... 21
5.2.1.2	Design characteristics..... 31
5.2.1.3	Hand cranks..... 31
5.2.1.4	Handwheels..... 32
5.2.1.5	Keylocks and keylock switches 37
5.2.1.6	Knobs 41
5.2.1.7	Legend switches 45
5.2.1.8	Levers 48

MIL-HDBK-759B

CONTENTS

<u>PARAGRAPH</u>		<u>Page</u>
5.2.1.9	Foot-operated controls	49
5.2.1.10	Push button switches	61
5.2.1.11	Keyboards, keypads, keysets and menu selectors	66
5.2.1.12	Rotary controls	73
5.2.1.13	Discrete controls	83
5.2.1.14	Push-pull controls	89
5.2.1.15	Printed circuit switch controls	94
5.2.1.16	Integral, handle-mounted controls	94
5.2.1.17	Slide switch controls	96
5.2.1.18	Two-axis controllers for display system applications	99
5.2.1.19	Miniature controls	108
5.2.1.20	Touch-screen controls for displays	108
5.2.2	Displays	109
5.2.2.1	General criteria	109
5.2.2.2	Transilluminated displays	115
5.2.2.3	Scalar indicators	122
5.2.2.4	Cathode-ray tube displays	137
5.2.2.5	Large-screen displays	150
5.2.2.6	Other displays	151
5.2.2.7	Speech input and audio displays	162
5.2.3	Consoles	173
5.2.3.1	Standard console design	173
5.2.3.2	Special-purpose console design	176
5.2.3.3	Display surfaces	178
5.2.3.4	Control surfaces	179
5.2.3.5	Standing operations	181
5.2.3.6	Control/display integration	181
5.2.3.7	Design factors	185
5.2.3.8	Control/display movement ratio	188
5.3	Dimensional workspace	190
5.3.1	Workspace	190
5.3.1.1	General	190
5.3.2	Anthropometry	190
5.3.2.1	General	190
5.3.2.2	Anthropometric data	191
5.3.2.3	Use of data	191
5.3.2.4	Other data	233
5.3.3	Body movement	247
5.3.3.1	Range of human motion	247
5.3.3.2	Whole body	247
5.3.4	Human strength and handling capacity	252
5.3.4.1	Exerted forces	252
5.3.4.2	Push and pull forces	252
5.3.4.3	Lifting	252

MIL-HDBK-759B

CONTENTS

<u>PARAGRAPH</u>		<u>Page</u>
5.3.4.4	Lifting limits	260
5.3.4.5	Lifting frequency	260
5.3.4.6	Load size	260
5.3.4.7	Obstacles	261
5.3.4.8	Carrying limits	261
5.3.4.9	Carrying frequency	261
5.3.4.10	Object carry size	261
5.3.4.11	User population	267
5.3.4.12	Other application limits	261
5.3.4.13	Labeling	261
5.3.5	Workstation entrance and exit	262
5.3.5.1	Routine	262
5.3.5.2	Non-routine	262
5.3.6	Stairs, ladders and ramps	262
5.3.6.1	General	262
5.3.6.2	Angle of inclination	263
5.3.6.3	Ladders	263
5.3.6.4	Stairs	267
5.3.6.5	Ramps	267
5.3.7	Walkways and passageways	270
5.3.7.1	General	270
5.3.7.2	Clearance	270
5.3.7.3	Floors	270
5.3.8	Doors	270
5.3.8.1	General	270
5.3.8.2	Sliding doors	272
5.3.8.3	Vertical and sliding doors	272
5.3.9	Escape hatches	272
5.3.9.1	General	272
5.3.9.2	Emergency hatches	272
5.3.9.3	Wall hatches	272
5.3.9.4	Dimensions	272
5.3.10	Platforms	273
5.3.10.1	General	273
5.3.10.2	Portable platforms	273
5.3.10.3	Equipment on platforms	273
5.3.10.4	Handrails and toeboards	273
5.3.11	Guardrails and handrails	273
5.3.11.1	General	273
5.3.11.2	Uses	274
5.3.12	Seated workspace	275
5.3.12.1	General	275
5.3.12.2	Cushioning	275
5.3.12.3	Armrests	275

MIL-HDBK-759B

CONTENTS

<u>PARAGRAPH</u>		<u>Page</u>
5.3.12.4	Footrests	278
5.3.12.5	Temporary seats	278
5.3.12.6	Advantages	278
5.3.13	Standing workspace	278
5.3.13.1	General	278
5.3.13.2	Equipment placement	278
5.3.13.3	Advantages	278
5.3.14	Mobile workspace	281
5.3.15	Common working positions	281
5.4	Environment	288
5.4.1	Environmental factors	288
5.4.1.1	General	288
5.4.1.2	Environmental extremes	288
5.4.2	Hot environment	289
5.4.2.1	General	289
5.4.2.2	Effective temperature	289
5.4.2.3	Measurement methods	293
5.4.2.4	Limited thermal tolerance zone	293
5.4.2.5	Humidity	294
5.4.2.6	Air conditioning	294
5.4.2.7	Ventilation	294
5.4.3	Cold environment	295
5.4.3.1	Windchill	295
5.4.3.2	Mobile personnel enclosures	297
5.4.3.3	Permanent and semi-permanent personnel enclosures	297
5.4.4	Vehicle design thermal considerations	297
5.4.4.1	Vehicular heat sources	297
5.4.4.2	Vehicle and equipment operator enclosure and personnel compartment	299
5.4.4.3	Troop carrier vehicles	299
5.4.4.4	Tanks	299
5.4.4.5	Surface temperatures	299
5.4.5	Illumination	300
5.4.5.1	General	300
5.4.5.2	Illumination levels and distribution	300
5.4.5.3	Illumination levels and vehicle fighting compartments	300
5.4.5.4	Lighting fixtures	306
5.4.5.5	Brightness ratios	307
5.4.5.6	Glare	307
5.4.5.7	Reflectance	308
5.4.5.8	Dark adaptation	308
5.4.6	Acoustical noise	310

MIL-HDBK-759B

CONTENTS

<u>PARAGRAPH</u>		<u>Page</u>
5.4.6.1	General	310
5.4.6.2	Hazardous noise	310
5.4.6.3	Non-hazardous noise	310
5.4.6.4	Facility design	311
5.4.7	Noxious substances	311
5.4.7.1	General	311
5.4.7.2	Carbon monoxide	312
5.4.7.3	Nitrogen oxides	312
5.4.7.4	Concentrations	312
5.4.7.5	Evaluation of carbon monoxide toxic hazard.	312
5.4.7.6	Weapon combustion products	314
5.4.7.7	Exhaust combustion products	314
5.4.8	Protection against chemical warfare agents	314
5.4.8.1	Basic protection	314
5.4.8.2	Overpressure collective protection system	315
5.4.8.3	Protective ensemble	316
5.4.8.4	Human factors in testing	316
5.4.9	Radiation	316
5.4.9.1	General	316
5.4.9.2	Microwave radiation	316
5.4.9.3	Nuclear radiation	317
5.4.10	Dust	317
5.4.10.1	Dust concentration	317
5.4.10.2	Ventilation system	317
5.4.10.3	Personnel protection	317
5.4.11	Mud and water	317
5.4.11.1	General	317
5.4.12	Vibration	317
5.4.12.1	Vibration effects on performance.	317
5.4.12.2	Vibration limits	317
5.4.12.3	Equipment vibrations	319
5.4.12.4	Design for reduction and control.	319
5.5	Labels, colors and markings	322
5.5.1	Labels, legends, placards, signs and markings	322
5.5.1.1	General	322
5.5.1.2	Orientation and location	323
5.5.1.3	Content	325
5.5.1.4	Qualities	325
5.5.1.5	Design of letters, numerals and symbols	327
5.5.1.6	Equipment labeling	329
5.5.1.7	Control/display labeling.	332
5.5.1.8	Labeling for identification	335
5.5.2	Colors and marking	336
5.5.2.1	Painting and marking	336
5.5.2.2	Colors	337

MIL-HDBK-759B

CONTENTS

<u>PARAGRAPH</u>		<u>Page</u>
5.6	Maintenance	337
5.6.1	Maintainability	337
5.6.1.1	General	337
5.6.1.2	Maintainability in the design schedule	337
5.6.1.3	Manuals	339
5.6.2	Stowage	339
5.6.2.1	General	339
5.6.2.2	Identification	340
5.6.2.3	Interference	340
5.6.2.4	Retaining devices	340
5.6.2.5	Utilization of stowage space	340
5.6.3	Effects of climate on maintenance personnel	341
5.6.3.1	General	341
5.6.3.2	Temperature extremes	341
5.6.3.3	Heat	341
5.6.3.4	Cold and windchill	342
5.6.4	Tools	344
5.6.4.1	General	344
5.6.4.2	Other design and maintenance considerations	344
5.6.4.3	Safety features	345
5.6.5	Accessibility/maintainability	345
5.6.5.1	General	346
5.6.5.2	Psychological aspects	346
5.6.5.3	'Whole body' access	346
5.6.5.4	Visual access	346
5.6.5.5	Environment	346
5.6.6	Workspace criteria	347
5.6.6.1	General	347
5.6.6.2	Other features	347
5.6.7	General-access criteria	347
5.6.7.1	Design	347
5.6.7.2	Visual inspection	347
5.6.7.3	Sharp edges	347
5.6.8	Access	348
5.6.8.1	General	348
5.6.8.2	Access design	353
5.6.8.3	Shape of accesses	353
5.6.8.4	Size of accesses	353
5.6.8.5	Location of accesses	353
5.6.9	Connectors	354
5.6.9.1	General considerations	354
5.6.9.2	Classification of connectors	356
5.6.9.3	Electrical connectors	356
5.6.10	Covers, cases and shields	362

MIL-HDBK-759B

CONTENTS

<u>PARAGRAPH</u>		<u>Page</u>
5.6.10.1	General	362
5.6.10.2	Cases l.....	365
5.6.10.3	Covers	365
5.6.11	Fasteners.....	366
5.6.11.1	General.....	366
5.6.11.2	Types of fasteners.....	368
5.6.12	Equipment units access checklist	370
5.6.13	Handles	371
5.6.13.1	Design and locations	371
5.6.13.2	Dimensions, location and position.....	371
5.6.13.3	Location	373
5.6.13.4	Other considerations	373
5.6.14	Drawers and racks for equipment units	373
5.6.14.1	General	373
5.6.14.2	Retaining devices l.....	374
5.6.14.3	Internal connectors.....	375
5.6.15	Handling equipment.....	375
5.6.15.1	General	375
5.6.15.2	Jacks	375
5.6.15.3	Cranes	375
5.6.15.4	Hoists	376
5.6.16	Lines and cables.....	376
5.6.16.1	General	376
5.6.16.2	Fluid and gas lines	378
5.6.16.3	Electrical wires and cables	379
5.6.16.4	Cable routing.....	380
5.6.17	Cabling and connectors checklist.....	383
5.6.17.1	General	383
5.6.17.2	Cables.....	384
5.6.17.3	Connectors.....	385
5.6.18	Mounting and packaging.....	386
5.6.18.1	General	386
5.6.18.2	Mounting	388
5.6.18.3	Straps and brackets	388
5.6.18.4	Guides and guide pins.....	388
5.6.18.5	Shock mounts.....	388
5.6.18.6	Coding, marking and labeling.....	388
5.6.18.7	Packaging and mounting.....	390
5.6.18.8	Personnel safety	391
5.6.18.9	Removable pins, caps, and covers.....	391
5.6.18.10	Blind mounting	391
5.6.18.11	Fold-out construction	391
5.6.18.12	Braces	392
5.6.18.13	Spring clamps	393

MIL-HDBK-759B

CONTENTS

<u>PARAGRAPH</u>		<u>Page</u>
5.6.18.14	Other considerations	393
5.6.19	Replaceable units	394
5.6.19.1	General	394
5.6.19.2	Design recommendations	394
5.6.20	Location of individual components	397
5.6.20.1	Location and layout	397
5.6.21	Equipment units checklist	400
5.6.22	Test and service points	401
5.6.22.1	General	401
5.6.22.2	Test points checklist	407
5.6.22.3	Test equipment	409
5.6.23	Test equipment checklist	415
5.6.24	Electrical equipment	417
5.6.24.1	Batteries	417
5.6.24.2	Fuses and circuit breakers	418
5.6.24.3	Relays	419
5.6.24.4	Ignition equipment	420
5.6.24.5	Dynamotors	421
5.6.24.6	Wiring and cables	421
5.6.25	Mechanical equipment	422
5.6.25.1	Accessibility	422
5.6.25.2	Standardization	423
5.6.25.3	Safety	423
5.6.25.4	Other design considerations	423
5.6.26	Hydraulics	425
5.6.26.1	General	425
5.6.26.2	Standardization	425
5.6.26.3	Identification	425
5.6.26.4	Drain cocks	425
5.6.26.5	Seals	426
5.6.26.6	Design considerations	426
5.7	Safety	428
5.7.1	General	428
5.7.1.1	Principles of human behavior related to safety	428
5.7.2	Electrical hazards	431
5.7.2.1	Electric shock	431
5.7.3	Mechanical and other hazards	437
5.7.3.1	Protrusions	437
5.7.3.2	Moving and high-temperature parts	437
5.7.3.3	Fire	438
5.7.3.4	Toxic fumes	438
5.7.3.5	Implosion and explosion	438
5.7.3.6	Instability	439
5.7.3.7	Ionizing and non-ionizing radiation	439

MIL-HDBK-759B

CONTENTS

<u>PARAGRAPH</u>		<u>Page</u>
5.7.4	Safety checklist	4 3 9
5.8	Systems application.. . . .	4 4 3
5.8.1	Ammunition	4 4 3
5.8.1.1	Projectile storage	4 4 3
5.8.1.2	Projectile transfer.. . . .	4 4 3
5.8.1.3	Ammunition stowage racks	4 4 3
5.8.1.4	Fuzes..	4 4 4
5.8.2	Armament	4 4 4
5.8.2.1	Primary armament	4 4 4
5.8.2.2	Secondary armament	4 4 6
5.8.2.3	Small arms..	4 4 8
5.8.3	Communications	4 5 2
5.8.3.1	General	4 5 2
5.8.3.2	Telephone	4 5 2
5.8.3.3	Loudspeaker	4 5 3
5.8.3.4	Receiver and headset	4 5 3
5.8.3.5	Talkers	4 5 3
5.8.3.6	Radio set	4 5 3
5.8.3.7	Radio antenna	4 5 4
5.8.3.8	Control box	4 5 4
5.8.3.9	Audio accessories	4 5 4
5.8.3.10	Cable routing	4 5 4
5.8.4	Equipment subsystems	4 5 4
5.8.4.1	Batteries	4 5 4
5.8.4.2	Brakes	4 5 6
5.8.4.3	Clutches..	4 5 7
5.8.4.4	Fuel System..	4 5 8
5.8.4.5	Engine..	4 5 9
5.8.4.6	Radiators..	4 6 0
5.8.4.7	Exhaust systems	4 6 0
5.8.4.8	Drains and vents	4 6 1
5.8.4.9	Filling, draining, and checking procedures	4 6 1
5.8.4.10	Chassis..	4 6 2
5.8.4.11	Intravehicular coupling device	4 6 2
5.8.4.12	Spare tires..	4 6 2
5.8.4.13	Ladders for trailers and vans	4 6 3
5.8.4.14	Canvas and accessories..	4 6 4
5.8.4.15	Horns..	4 6 4
5.8.4.16	Heaters..	4 6 4
5.8.4.17	Seating..	4 6 5
5.8.4.18	Lighting system..	4 6 5
5.8.4.19	Mirrors..	4 7 0
5.8.4.20	Windshields	4 7 1
5.8.4.21	Windshield wipers	4 7 1

MIL-HDBK-759B

CONTENTS

<u>PARAGRAPH</u>		<u>Page</u>
5.8.4.22	Windows	472
5.8.5	Crew stations in combat vehicles	472
5.8.5.1	Hatches	472
5.8.5.2	Crawl space	473
5.8.5.3	Crew compartment lighting	475
5.8.5.4	Cupolas	475
5.8.5.5	Travel locks	475
5.8.5.6	Crew compartment safety	476
5.8.5.7	Brow pads	476
5.8.5.8	Vision blocks and periscopes	477
5.8.5.9	Commander's station	477
5.8.5.10	Gunner's station	478
5.8.5.11	Loader's station	479
5.8.5.12	Driver's station	480
5.8.6	Tank gun control systems	480
5.8.6.1	General	480
5.8.6.2	Manual controls	481
5.8.6.3	Power controls	482
5.8.6.4	Fire mntrol maintenance	484
5.8.7	Optical instruments and associated equipment	485
5.8.7.1	General	485
5.8.7.2	Visual parameters	485
5.8.7.3	Optical parameters	486
5.8.7.4	Environmental conditions	488
5.8.7.5	Accessories	489
5.8.7.6	Mounts and supports	492
5.8.7.7	Lighting	492
5.8.7.8	Maintenance	495
5.8.7.9	Component replacement	495
5.8.8	Personnel-computer interface	495
6.	NOTES	497
6.1	Intended use	497
6.2	Subject term listing	497
6.3	Changes from previous issue	497
 <u>FIGURE</u>		 <u>Page</u>
1	Cranks	33
2	Proper mounting of rapidly operated crank	34
3	Keylock mounting criteria	38
4	Keylock criteria	39
5	Keylock switch criteria	40
6	Knobs	42

MIL-HDBK-759B

CONTENTS

<u>FIGURE</u>		<u>Page</u>
7	Knob rotation	43
8	Set screws for control knobs	43
9	Recommended knob shapes	43
10	Easily recognizable knob shapes	44
11	Ganged knobs	46
12	Legend switch	47
13	Foot-operated switches	57
14	Multi-function keyset format examples	72
15	Menu selector types and format examples	74
16	Rotating knob separation	80
17	Thumbwheel orientation and movement	81
18	Discrete thumbwheel control	82
19	Thumbwheel adjustment controls	84
20	Toggle switch orientation for ON	90
21	Rocker switches	91
22	Slide switches	100
23	Ball controls	103
24	Isotonic joysticks	105
25	Lines of sight	112
26	Visual field	114
27	Scale graduation, pointer position and scale numbering alternatives	126
28	Fixed-scale azimuth dials	127
29	Shape/color coding operating ranges	129
30	Zero position and pointer movement for circular dial displays	130
31	Aligned pointers for rapid check-reading	132
32	Relative position of scale marks, numerals and pointers on circular dials	133
33	Relative position of scale marks, numerals and pointers on arc and straight-line scales	134
34	Digit light counter arrays	153
35	Drum-type counter design	155
36	Minimal criteria for dot and segmented matrix characters	156
37	Standard console dimensions key	174
38	Example of wrap-around console	177
39	Example of vertical/stacked segments	177
40	Seated optimum manual control space	180
41	Control/display relationship	187
42	US Army men (1988): standing and sitting measurements	196
43	US Army men (1988): breadth and circumference measurements	198

MIL-HDBK-759B

CONTENTS

<u>FIGURE</u>		<u>Page</u>
44	US Army men (1988): surface, head and face measurements	200
45	US Army men (1988): hand and foot measurements	202
46	US Army women (1988): standing measurements	204
47	US Army women (1988): sitting, depth and breadth measurements	206
48	US Army women (1988) circumference measurements	208
49	US Army women (1988): surface measurements	210
50	US Army women (1988): head and face measurements	212
51	US Army women (1988): hand and foot measurements	214
52	US Army male/female pilots (1988): standing and sitting measurements	216
53	US Army male/female pilots (1988): breadth and joint breadths, bone	220
54	US Army male/female pilots (1988): circumference measurements	222
55	US Army male/female pilots (1988): surface, head and face measurements	226
56	US Army male/female pilots (1988): hand and foot measurements	230
57	Body dimensions	234
58	PASGT helmet dimensions	241
59	M-1 helmet dimensions	242
60	CVC helmet -DH132 dimensions	243
61	Aircrewman's helmet-SPH4 dimensions	244
62	Gloved-hand dimensions for 95th percentile male	245
63	Range of human motion	248
64	Arm, hand and thumb-finger strength (5th percentile male)	253
65	Leg strength at various knee and thigh angles	254
66	Static muscle strength data	257
67	Incline angles for the use of various structures	264
68	Stair-ladder dimensions	265
69	Rung-ladder and ladder-cage dimensions	265
70	Step-ladder dimensions	266
71	Fixed-ladder dimensions	266
72	Stair dimensions	268
73	Ramp dimensions	269
74	Door dimensions	270
75	Walkway and passageway dimensions	271
76	Guardrail and handrail dimensions	274
77	Seated workspace dimensions	276
78	Swing-away seat for short-term operations	279
79	Standing workspace dimensions	280

MIL-HDBK-759B

CONTENTS

<u>FIGURE</u>		<u>Page</u>
80	Mobile workspace dimensions	282
81	Anthropometric data for workspaces	284
82	Deriving effective temperature	290
83	Summer and winter comfort zones and thermal tolerance for inhabited compartments	292
84	Ventilation values for larger enclosures	295
85	Windchill chart	296
86	Equivalent chill temperature	298
87	Burn criteria for human skin	301
88	Glare recovery time curves for map reading after five minutes exposure to outside light	305
89	Workspace reflectance values	309
90	Vibration exposure criteria for longitudinal and transverse directions with respect to body axis	320
91	The 90 percent motion sickness protection limits for human exposure to very low-frequency vibration	321
92	Location and position of labels	324
93	Character height criteria for instruments, panels and equipment viewed in close proximity	330
94	Character height criteria for viewing signs at extended distances	331
95	Label size-hierarchy example for equipment, panel, subpanel and component identification	333
96	Change in performance decrement at different ambient temperatures	342
97	One-hand access openings	349
98	Access opening dimensions	350
99	Covers and accesses	352
100	Coding of connectors	359
101	Methods of identifying plugs and receptacles to prevent mismatching	360
102	Covers and cases: design examples	363
103	Fastener examples	367
104	Handle dimensions	372
105	Pull-out, roll-out, and slide-out drawers for components requiring frequent checks	374
106	Cable inspection	381
107	Preformed cables	381
108	Routing cables	382
109	Cable connections	382
110	Cable bends	382
111	Methods for recoiling service loops in sliding chassis	384
112	Cable winder and cover	384
113	Fold-out construction for electronic chassis	392

MIL-HDBK-759B

CONTENTS

<u>FIGURE</u>		<u>Page</u>
114	Hinged assemblies	392
115	Use of maintenance stands	393
116	Use of spring damps	393
117	Alignment guides and guide pins	395
118	Equipment removal	395
119	Use of side-alignment brackets	396
120	Types of AN connectors	396
121	Hinged units	398
122	Component placement	399
123	Tube sockets orientation	399
124	Alternate methods for grouping test points	405
125	Test points on replaceable units	406
126	Hand-held testers	413
127	Cable connections	422
128	Use seals which are visible after installation	426
129	Connectors for fluid lines	428
130	Door interlock switch	433
131	Automatic shorting bars	434
132	435
133	Cabinet grounding system	435
134	Correct manner of wiring instrument-type fuse holder	436
135	Effects of incline on center of gravity location of equipment	440
136	Retainers for floor mounted vertical ammunition and missile ready racks	445
137	Dimensions guidance, rifle and machine guns	450
138	Dimensions for vehicle operator's seat	466
139	Recommend clearances around equipment operator's station	468
140	Contoured hatch dimensions	474
141	Optimum power-traverse response rates	483
142	Anatomical limits on auxiliary symmetrical ocular metal parts	490
143	Accelerations to human gunner firing 152mm gun from M60A2 tank	493
144	Accelerations to human gunner firing 152mm gun from M551 Sheridan vehicle	494

MIL-HDBK-759B

CONTENTS

1	Control selection criteria	22
2	Recommended manual controls	24
3	Conventional control movement stereotypes	25
4	Minimum separation distances for panel-mounted controls	28
5	Recommended control colors (FED-STD-595)	30
6	Handwheels	35
7	Levers	50
8	Foot-operated controls	59
9	Representative push button switch applications	62
10	Push button switches	63
11	Keyboards	68
12	Nominal keyboard characteristics	69
13	Knob detent placement	75
14	Rotary selector controls	77
15	Toggle switches	85
16	Push-pull controls	93
17	Grip switches	97
18	Two-axis controllers for display system applications	101
19	Coding of simple indicator lights	119
20	Application of various types of mechanical displays	123
21	Scale of markings	125
22	CRT phosphor applications and characteristics	139
23	Character sizes for mechanical counters (mm)	154
24	Group viewing of optical projection displays	162
25	Functional evaluation of audio signals	164
26	Standard console dimensions	175
27	A bivariate frequency table for waist circumference and crotch height	194
28	US Army men (1988): standing and sitting measurements	197
29	US Army men (1988): breadth and circumference measurements	199
30	US Army men (1988): surface, head and face measurements	201
31	US Army men (1988): hand and foot measurements	203
32	US Army women (1988): standing measurements	205
33	US Army women (1988): sitting, depth and breadth measurements	207
34	US Army women (1988): circumference measurements	209
35	US Army women (1988): surface measurements	211
36	US Army women (1988): head and face measurements	213

MIL-HDBK-759B

CONTENTS

<u>TABLE</u>	<u>Page</u>
37	US Army women (1988): hand and foot measurements 215
38	US Army male pilots (1988): standing and sitting measurements 217
39	US Army female pilots (1988): standing and sitting measurements 218
40	US Army male pilots (1988): breadth and joint breadths, bone 221
41	US Army female pilots (1988): breadth and joint breadth, bone 221
42	US Army male pilots (1988): circumference measurements . . . 223
43	US Army female pilots (1988): circumference measurements 224
44	US Army male pilots (1988): surface, head and face measurements 227
45	US Army female pilots (1988): surface, head and face measurements 228
46	US Army male pilots (1988): hand and foot measurements 231
47	US Army female pilots (1988): hand and foot measurements 231
48	Body dimensions measurements, including arctic clothing 235
49	Clothed body dimensions of the 5th and 95th percentile soldier 240
50	Range of human motion 249
51	Horizontal push and pull forces exertable 255
52	Static muscle strength data 256
53	Design weight limits 260
54	Seated workspace dimensions 277
55	Standing workspace dimensions 281
56	Mobile workspace dimensions 283
57	Anthropometric data for common working positions 288
58	Illumination criteria for representative tasks 302
59	Specific-task illumination criteria 303
60	Levels of illumination for efficient performance of various tasks in vehicle fighting compartments 306
61	Brightness ratios 307
62	Constants for substitution in empirical equation used to predict COHb blood content 313
63	Noxious exhaust products of engine fuels 315
64	Summary of dust concentrations to which armored personnel are exposed 318
65	Close equivalent type faces suitable for labeling 328
66	One-hand access openings 349

MIL-HDBK-759B

CONTENTS

<u>TABLE</u>		<u>Page</u>
67	Electrical cable coding	361
68	Hydraulic and pneumatic coding	362
69	Weight and dimension limits of portable test equipment	412
70	General comparison of fuses and circuit breakers	420
71	Shock current intensities and their probable effects	431
72	Recommended station dimensions/clearances to accommodate the 95th percentile equipment operator dressed in arctic clothing	469
73	English equivalents and abbreviations	500
APPENDIX	English equivalents and abbreviations	499
INDEX	501

MIL-HDBK-759B

This Page Intentionally Left Blank.

MIL-HDBK-759B

1. SCOPE

1.1 Scope. This handbook provides human factors engineering guidelines, preferred practices, and reference data for design of Army materiel. (Programmatic and technique-oriented guidelines may be found in DOD-HDBK-763.)

1.2 Applicability.

1.2.1 Application. The function- and commodity-oriented design guidelines and practices provided by this handbook apply to Army systems, equipment, and facilities. They may be applied during any phase of acquisition, as appropriate, where design influence, design, or design evaluation is involved. (While human engineering design of user-computer interaction is briefly covered herein, a more comprehensive treatment of that subject is provided by MIL-HDBK-761.)

1.2.2 Selection of hardware, materials or processes. Nothing in this handbook should be construed as limiting the selection of hardware, materials, or processes to items that may be described herein.

1.2.3 Gender considerations. Army materiel is designed for operation, maintenance, and control by both male and female soldiers. Accordingly and unless stated otherwise, the design guidelines, preferred practices, and data herein apply to design of systems, equipment, and facilities for use by both men and women. The use of "he" or "his" should be taken to indicate "he or she" or "his or her".

1.2.4 Manufacturing tolerances. When manufacturing tolerances are not perceptible to the user, the guidelines and preferred practices herein should not be interpreted in a manner preventing the use of components whose dimensions are within a normal manufacturing upper or lower limit tolerance of the dimensions specified herein.

MIL-HDBK-759B

This Page Intentionally Left Blank.

MIL-HDBK-759B

2. APPLICABLE DOCUMENTS

2.1 Government documents.

2.1.1 Specifications, standards, and handbooks. The following specifications, standards, and handbooks form a part of this document to the extent specified herein. Unless otherwise specified, the issues of these documents are those listed in the issue of the Department of Defense Index of Specifications and Standards (DODISS) and supplement thereto, cited in the solicitation.

SPECIFICATIONS

MILITARY

MIL-P-514	Plate, Identification, Instruction and Marking, Blank
MIL-C-3702	Cable, Power, Electrical, Ignition, High-Tension
MIL-L-3976	Light, Marker, Clearance, Service and Blackout
MIL-P-7788	Panels, Information, Integrally Illuminated
MIL-B-8584	Brake Systems, Wheel, Aircraft, Design of
MIL-F-8785	Flying Qualities of Piloted Airplanes
MIL-A-8806	Acoustical Noise Level in Aircraft, General Specification for
MIL-S-008806	Sound Pressure Levels in Aircraft, General Specification for
MIL-C-13486	Cable, Special Purpose, Electrical. Low-Tension, Heavy-duty Multiple Conductors
MIL-F-I5160	Fuses, Instrument, Power and Telephone
MIL-M-18012	Markings for Aircrew Station Displays, Design and Configuration of
MIL-T-23991	Training Devices, Military, General Specification for
MIL-C-25050	Color, Aeronautical Lights and Lighting Equipment, General Requirements for

MIL-HDBK-759B

MIL-C-81774 Control Panel, Aircraft, General Requirements for

STANDARDS

FEDERAL

FED-STD-595 Colors (Requirements for Individual Color Chips)

MILITARY

MIL-STD-12 Abbreviations for Use on Drawings, Specifications, Standards, and in Technical Documents

MIL-STD-188/100 Common Long Haul and Tactical Communication System Technical Standards

MIL-STD-195 Marking of Connections for Electrical Assemblies

MIL-STD-203 Aircrew Station Controls and Displays: Location, Arrangement and Actuation of, for Fixed Wing Aircraft

MIL-STD-250 Aircrew Station Controls and Displays for Rotary Wing Aircraft

MIL-STD-411 Aircrew Station Alerting Signals

MIL-STD-454 Standard General Requirements for Electronic Equipment

MIL-STD-681 Identification Coding and Application of Hookup and Lead Wire

MIL-STD-685 Identification of Cable Used for Transmission of Telephone, Telegraph and Teletype Signals

MIL-STD-686 Cable and Cord, Electrical, Identification Marking and Color Coding of

MIL-STD-740/2 Structureborne Vibratory Acceleration Measurements Acceptance Criteria of Shipboard Equipment

MIL-HDBK-759B

MIL-STD-783	Legends for Use in Aircrew Stations and on Airborne Equipment
MIL-STD-884	Electronically or Optically Generated Displays for Aircraft Control and Combat Cue Information
MIL-STD-1280	Keyboard Arrangements
MIL-STD-1333	Aircrew Station Geometry for Military Aircraft
MIL-STD-1472	Human Engineering Design Criteria for Military Systems, Equipment and Facilities
MIL-STD-1473	Standard General Requirements for Color and Marking of Army Material
MIL-STD-1474	Noise Limits for Military Materiel
MS-87017	Switch, Arrangement and Functions, Grip Assembly, Cyclic Controller, For
MS-91528	Control-Knob, Plastic (Round, Concentric, Pointer, Spinner, Spinner Slip Clutch, Bar, Tactile, Knob Lock Pointer, and Knob Locks)

HANDBOOKS

DOD-HDBK-763	Human Engineering Procedures Guide
MIL-HDBK-761	Human Engineering Guidelines for Management Information Systems

(Unless otherwise indicated, copies of federal and military specifications, standards and handbooks are available from the Naval Publications and Forms Center (ATTN: NPODS), 5801 Tabor Avenue, Philadelphia, PA 19120-5099.)

2.1.2 Other government documents, drawings, and publications. The following other government documents, drawings and publications form a part of this document to the extent specified herein. Unless otherwise specified, the issues are those cited in the solicitation.

MIL-HDBK-759B

PUBLICATIONS

ARMY

AR 70-38	Test and Evaluation of Materiel for Extreme Climatic Conditions
AR 385-30	Safety Color Code Markings and Signs
FM 31-71	Northern Operations
HEL TM 10-73	Noise and Blast; Hedge, D.C. & Garinther, G. R.; US Army Human Engineering Laboratory
NRDEC 54-84/034	Anthropometry of the Clothed US Army Ground Troop and Combat Vehicle Crewman; Johnson, R. F.; US Army Natick Research, Development, and Engineering Center

NAVY

BUMEDINST 6260.6	Hearing Conservation Program
NAEC-TR-2100-07B	A Family of Manikins for Workstation Design; Bittner, A.; Naval Air Engineering Center
PMTC TP-75-49	Computerized Accommodated Percentile Evaluation (CAPE) Model for Cockpit Analysis and Other Exclusion Studies; Bittner, A.; Pacific Missile Test Center

AIR FORCE

AFR 161-35	Hazardous Noise Exposure
TB-MED 161-7	Microwave Radiation
TB-MED 175	

NATIONAL AERONAUTICS AND SPACE ADMINISTRATION (NASA)

Ref. Pub. 1024	Anthropometric Source Book, Volume 1: Anthropometry for Designers
----------------	---

FEDERAL

20 CFR 10	Title 20 (Employee Benefits), Code of Federal Regulations, Part 10
-----------	--

MIL-HDBK-759B

29 CFR 1910	Occupational Safety and Health Standards
FMVSS-101	Federal Motor Vehicle Safety Standards

(Copies of other government documents, drawings, and publications required by contractors in connection with specific procurement functions should be obtained from the acquiring activity or as directed by the contracting officer.)

2.2 Non-government publications. The following document(s) form a part of this document to the extent specified herein. Unless otherwise specified, the issues of the documents which are DoD adopted are those listed in the issue of the DODISS cited in the solicitation. Unless otherwise specified, the issues of documents not listed in the DODISS are the issues of the documents cited in the solicitation.

AMERICAN NATIONAL STANDARDS INSTITUTE (ANSI)

ANSI A13.1	Scheme for the Identification of Piping Systems
ANSI C1	National Electrical Code (NFPA 70)
ANSI Z24.3	
ANSI Z35.1	Specifications for Accident Prevention Signs
ANSI Z53.1	Safety Color Code for Marking Physical Hazards

(Application for copies should be addressed to the American National Standards Institute, Inc., 1430 Broadway, New York, NY 10018.)

INTERNATIONAL STANDARDIZATION ORGANIZATION (ISO)

ISO DIS 2631	Guide to the Evaluation of Human Exposure to Whole Body Vibration
--------------	---

(Application for copies should be addressed to the American National Standards Institute, Inc., 1430 Broadway, New York, NY 10018.)

SOCIETY OF AUTOMOTIVE ENGINEERS (SAE)

SAE TP-810217	An Alternative to Percentile Model
---------------	------------------------------------

(Application for copies should be addressed to the Society of Automotive Engineers, 400 Commonwealth Drive, Warrendale, PA 15096-0001.)

(Non-government standards and other publications are normally available from the organizations that prepare or distribute the documents. These documents also may be available in or through libraries or other informational services.)

MIL-HDBK-759B

2.3 Order of precedence. In the event of a conflict between the text of this document and the references cited herein, the text of this document takes precedence. Nothing in this document, however, supersedes applicable laws and regulations unless a specific exception has been obtained.

MIL-HDBK-759B

This Page Intentionally Left Blank.

MIL-HDBK-759B

This Page Intentionally Left Blank.

MIL-HDBK-759B**3. DEFINITIONS**

3.1 A-duration (pressure wave duration). The time required for the pressure to rise to its initial or principal positive peak and return momentarily to ambient pressure.

3.2 Accessible. Except where stated to the contrary herein or where specific design values are given, an item is considered accessible only where it can be operated, manipulated, removed or replaced by suitably-clothed and -equipped users with applicable 5th and 95th percentile body dimensions. Applicable body dimensions are those dimensions which are design-critical to the operation, manipulation, removal, or replacement task.

3.3 Advisory signal. A signal to indicate safe or normal configuration, condition of performance, operation of essential equipment, or to attract attention and impart information for routine action purposes.

3.4 Ambient light. The light surrounding the particular control, display, panel, workstation, or piece of equipment.

3.5 Amplitude (acoustic). The amplitude of sound at any given point is expressed as Sound Pressure Level (SPL). Its physical unit is the decibel (dB) and is expressed as:

$$\text{SPL} = 20 \text{ Log}_{10} (p/p_0)$$

where p = the sound pressure being measured and p_0 = a reference pressure, usually 20 micronewtons per square meter.

3.6 B-duration pressure envelope duration). The total time that the envelope of pressure fluctuations is within 20 dB of the peak pressure level. Included in this time would be the duration of that part of any reflection pattern that is within 20 dB of the peak pressure level.

3.7 Backup. A capability that returns a user to the last previous display in a defined transaction sequence. Also refers to the practice of preserving a second copy of files for data protection purposes.

3.8 Battle-short switch. A switch used on high-priority equipment designed to bypass or short circuit interlock switches or devices during emergency conditions.

3.9 Cathode-ray tube (CRT). A vacuum tube in which a hot cathode emits electrons that are accelerated as a beam through a high-voltage anode, focused and allowed to fall on a fluorescent screen.

3.10 Caution signal. A signal which alerts the operator to an impending dangerous condition requiring attention, but not necessarily immediate action.

MIL-HDBK-759B

3.11 Command and control system equipment. The main mission element equipment and related ground equipment used in collecting, transmitting, processing, and displaying information for command and control.

3.12 Common hand tools. Tools found in common usage or applicable to a variety of operations or to a single operation on a variety of materiel. Screwdrivers, hammers, and wrenches are examples of common hand tools.

3.13 Control entry. User input for sequence control such as function key actuation, menu selection, or command entry.

3.14 Data. The raw materials from which a user extracts information. Data may include numbers, words, or pictures.

3.15 Data display. Output of data from a computer to its users. Generally, the phrase denotes visual output, but it may be qualified to indicate a different modality, such as an auditory display.

3.16 Data entry. User input of data for computer processing and computer responses to such inputs.

3.17 Data field. An area of the display screen reserved for user entry of a data item.

3.18 Data item. A set of characters of fixed or variable length that form a single unit of data. Examples of a data item might be a person's name or a ZIP code. Data items may be entered by a user or may be supplied by the computer.

3.19 Data protection. Functional capabilities that guard against unauthorized data access and tampering, user errors, and computer failure.

3.20 dB(A). The unit used to express sound level measured through the A-weighted network of a sound level meter.

3.21 Default value. A predetermined, frequently used value for a data field or control entry intended to reduce required user entry actions.

3.22 Display format. The organization of different types of data in a display, including information about the data (such as labels) and other user guidance (such as prompts and error messages),

3.23 Effective temperature. An arbitrary index which combines into a single value the effect of temperature, humidity, and air movement on the sensation of warmth or cold felt by the human body. The numerical value is that of the temperature of still, saturated air which would induce an identical sensation.

MIL-HDBK-759B

3.24 Enter. An explicit user action that effects computer processing of user entries. For example, after typing a series of numbers, a user might press an ENTER key that will add them to a data base, subject to data validation.

3.25 Equipment. General term designating any item or group of items.

3.26 Equipment failure. An equipment failure is the cessation of the ability to meet the minimum performance criteria of the equipment specifications. Further, equipment failure implies that the minimum specified performance cannot be restored through permissible readjustment of operator controls.

3.27 Facilities. A physical plant, such as real estate or improvements thereto, including building and equipment, which provides the means for assisting or making easier the performance of a system function. The facilities to which this handbook applies are those in which personnel perform system operational or maintenance

3.28 Fail-safe desire. A fail-safe design is one in which a failure will not adversely affect the safe operation of the system, equipment, or facility.

3.29 Flicker. The refresh (repaint) rate of signals or data displayed on a CRT.

3.30 Head-up display. A positional/command display typically projected on the primary windscreen of an aircraft cockpit to provide the pilot with operational information without having to look down at the cockpit instrument panel displays.

3.31 Human engineering design criteria. The summation of available knowledge which defines the nature and limits of human capabilities as they relate to the checkout, operation, maintenance or control of systems or equipment and which may be applied during engineering design to achieve optimum compatibility between equipment and human performance.

3.32 Information.Organized data that users need to successfully perform their tasks. Information serves as an answer to a user's questions about data. It is used here to refer to the effective assimilation of data by a user.

3.33 Interrupt. Stopping an ongoing transaction in order to redirect the course of the processing. Examples of interrupt options are ABORT, BACKUP, CANCEL, and RESTART.

3.34 Luminance contrast. The contrast between the background and a figure equals the difference between the higher luminance (L_1) and the lower luminance (L_2) divided by the lower luminance (L_2).

$$C = \frac{L_1 - L_2}{L_2}$$

MIL-HDBK-759B

Conversions to the other contrast formulae are as follows:

L1 (brighter)	L2 (dimmer)	$\frac{L1-L2}{L2}$	$\frac{L1-L2}{L1}$	$\frac{L1-L2}{L1+L2}$	$\frac{L1}{L2}$
100	50	1.0	0.50 (50%)	0.33	2.0
100	25	3.0	0.75 (75%)	0.60	4.0
100	10	9.0	0.90 (90%)	0.82	10.0

3.35 Luminance ratio (LR). The ratio of luminance between the target or subject and the surrounding field or background. For projection systems, the luminance ratio is equal to the light output of a projector (measured with no film in the projector) reflected off the screen (image luminance) divided by all the light falling on the screen (measured from the greatest viewing angle) other than that actually forming the image (non-image or background).

$$LR = \frac{L_i}{L_n} \text{ where: } L_i = \text{Image or subject luminance}$$

$$L_n = \text{Non-image or background luminance}$$

3.36 Maintainability. The ability to keep materiel in, or restoring it to, readiness and availability.

3.37 Master caution (warning) signal. A signal which indicates that one or more caution (warning) signals have been actuated.

3.38 Nuclear, biological, chemical (NBC) survivability. NBC survivability includes both the instantaneous, cumulative and residual effects of NBC weapons upon a system including its personnel. NBC survivability describes the capability of a system to withstand the NBC environment, including decontamination, without losing the ability to accomplish its mission. For any system to be considered survivable in an NBC contaminated battlefield, it should have at least three essential characteristics: Decontaminability, hardness, and compatibility.

- a. Decontaminability is the ability of a system to be rapidly decontaminated to reduce the hazard to personnel operating, maintaining, and resupplying it.
- b. Hardness is the ability of a system to withstand the materiel-damaging effects of NBC contamination and any decontamination agents and procedures required to remove it.
- c. Compatibility is the ability of a system to be effectively operated, maintained, and resupplied by persons wearing the full NBC protective ensemble.

3.39 Peak Pressure level (PPL). The highest dB level.

MIL-HDBK-759B

3.40 Primary controls. The most important and frequently used devices designed to control equipment and systems.

3.41 Rise time. The time taken for the single pressure fluctuation that forms the initial or principal positive peak to increase from ambient pressure to the PPL.

3.42 Seat reference point (SRP). The point at which the centerline of the seat back surface (depressed) and seat bottom surface (depressed) intersect. When the seat is positioned at the midpoint of the adjustment range(s), this intersection point is called the neutral seat reference point. (See MIL-STD-1333 for Army and Navy aircraft definition.)

3.43 Standard tools. Standard tools (normally hand tools) used for the assembly, disassembly, inspection, servicing, repair, and maintenance of equipment, and which are manufactured by two or more recognized tool manufacturing companies and listed in those companies' catalogs.

3.44 Tactual recognition (knobs). Knobs which have been designed into easily recognizable shapes and can be recognized by touch alone.

3.45 Transillumination. Light passed through rather than reflected off an element to be viewed such as illumination used on console panels or indicators utilizing edge and/or back lighting techniques on clear, translucent, fluorescent, or sandwich type plastic materials.

3.46 Warning signal. A signal which alerts the operator to a dangerous condition requiring immediate action.

3.47 Wet bulb globe temperature (WBGT). A meteorological measurement which can be used as an index to designate conditions of temperature and humidity at which onset of heat stress can be expected at a particular energy expenditure level. It is calculated as follows:

$$WBGT = 0.7T_{WB_{np}} + 0.2T_g + 0.1 T_A,$$

where $T_{WB_{np}}$ = non-psychometric (np) wet bulb (WB) temperature

T_g = temperature at interior center of a 15.2 cm (6 in) black globe

T_A = non-psychometric, but shaded, dry bulb (air) temperature.

MIL-HDBK-759B

3.48 White light. White light means light energy spanning a relatively wide range of wavelengths that allows users to distinguish colors even though the light may have some wavelengths that are more intense than others.

MIL-HDBK-759B**4. GENERAL GUIDELINES**

4.1 Objectives. The design of Army systems, equipment, and facilities should conform to the capabilities and limitations of the fully-equipped soldier to operate, maintain, supply, and transport the materiel in its operational environment consistent with tactical criteria and logistic capabilities. Accordingly, design-induced workload, accuracy, time constraints, mental processing, and communication requirements should not exceed operator/maintainer/controller capabilities. Design should also foster effective procedures, work patterns, and personnel safety and health, and minimize factors which degrade human performance. Design also should minimize personnel and training requirements within the limits of time, cost, and performance tradeoffs.

4.2 Human Performance. Design of Army systems, equipment, and facilities should reflect human engineering factors that affect human performance including:

- a. satisfactory atmospheric conditions (including composition, pressure, temperature, and humidity) and safeguards against uncontrolled variability beyond acceptable limits,
- b. satisfactory range of acoustic noise, vibration, acceleration, shock, blast, and impact forces and safeguards against uncontrolled variability beyond safe limits,
- c. effective protection from thermal, toxicological, radiological, mechanical, electrical, electromagnetic, pyrotechnic, visual, and other hazards,
- d. adequate space for soldiers, their equipment, and free volume for the movements and actions they are required to perform during operation and maintenance tasks under normal, adverse, and emergency conditions,
- e. adequate physical, visual, auditory, and other communication links between personnel, and between personnel and their equipment, under normal, adverse, and emergency conditions,
- f. efficient and effective arrangement of operation and maintenance workplaces, equipment, controls, and displays,
- g. provisions for ensuring safe, effective, and efficient task performance under reduced and elevated gravitational forces with safeguards against injury, equipment damage, and disorientation,
- h. adequate natural or artificial illumination for the performance of operations, control, training, and maintenance,
- i. safe and adequate passageways, hatches, ladders, stairways, platforms, inclines, and other provisions for ingress, egress, and passage under normal, adverse, and emergency conditions,

MIL-HDBK-759B

- j. provision of acceptable personnel accommodations including body support and restraint, seating, rest, and sustenance,
- k. provision of nonrestrictive personal life support and protective equipment,
- l. provisions for minimizing psychophysiological stress effects of mission duration and fatigue,
- m. design features to ensure rapidity, safety, ease, and economy of operation and maintenance in normal, adverse, and emergency environments,
- n. effective remote handling provisions and tools,
- o. adequate emergency systems for contingency management, escape, survival, and rescue, and
- p. compatibility of the design, location, and layout of controls, displays, workspaces, maintenance access, stowage provisions, and passenger compartments with the clothing and operational equipment to be worn by soldiers operating, riding in, or maintaining Army systems or equipment. Design-driven task allocation and control movements should be compatible with restrictions imposed on soldier performance by clothing and personal equipment.

4.3 Standardization. Controls, displays, marking, coding, labeling, and arrangement schemes (equipment and panel layout) should be uniform for common functions.

4.4 Equipment selection. Selection of off-the-shelf commercial or Government equipment should consider the degree to which the equipment conforms to human factors engineering guidelines and preferred practices. Where off-the-shelf equipment requires modification in order to interface with other equipment, the modification should be consistent with the guidelines and preferred practices herein.

4.5 Functional location. Design should reflect allocation of functions to soldiers, equipment, and soldier-equipment combinations to achieve:

- a. required sensitivity, precision, reaction time, and safety,
- b. required reliability of system performance,
- c. minimum number and level of skills of personnel required to operate and maintain the system, and
- d. required performance in a cost-effective manner.

4.6 Fail-safe design. A fail-safe design should be provided when component failure could cause catastrophic damage to equipment, injury to personnel, or inadvertent operation of critical equipment.

MIL-HDBK-759B

4.7 Simplicity of design. The equipment should represent the simplest design consistent with functional requirements and expected service conditions. It should be capable of being operated, maintained, and repaired in its operational environment by soldiers with a minimum of training.

4.8 Interaction. Design should facilitate effective and efficient accomplishment of interactive tasks with crew-served equipment.

4.9 Safety. Design should reflect applicable system and personnel safety factors, including minimization of potential human error in the operation and maintenance of the system, particularly under conditions of alert, battle stress, or other emergency or non-routine conditions.

4.10 Ruggedness. Systems and equipment should be sufficiently rugged to withstand handling in the field during operation, maintenance, supply, and transport within the environmental limits within which they are required to operate.

4.11 Design for NBC survivability. As applicable, equipment design should be compatible with NBC protection and should permit performance of mission-essential operations, communications, maintenance, resupply, and decontamination tasks by suitably-clothed, trained, and acclimatized soldiers for the survival periods and NBC environments required by the system. Equipment design should also facilitate NBC hardness surveillance and should minimize susceptibility to reduction of inherent NBC hardness as a result of maintenance/operator-induced errors/damage. The conditions stated below are examples.

- a. NBC hardness should be easily verifiable by maintenance personnel before and after maintenance actions (hardness surveillance).
- b. NBC hardness should not be degraded by routine (scheduled) or corrective (unscheduled) maintenance.
- c. Maintenance of the equipment's inherent NBC hardness should not be dependent on maintenance personnel expertise or critical alignments/maintenance actions.

4.12 Design for electromagnetic mlse (EMP) hardening. Equipment design should be compatible with EMP hardening criteria including personal accommodations such as EMP-hardened electrical power outlets and antenna lead-ins within EMP-hardened facilities or spaces. Access should be provided to EMP-hardened facilities or spaces without the need to open doors or hatches which form part of an electromagnetic barrier protecting the space. Items such as surge arrestors, terminal protection devices, and filters, which form part of an electromagnetic barrier for protection against EMP effects should be accessible.

MIL-HDBK-759B

This Page Intentionally Left Blank.

MIL-HDBK-759B

5. DETAILED GUIDELINES

5.1 General. This section contains detailed human factors engineering guidelines for design of military materiel.

5.2 Controls, displays and consoles.5.2.1 Controls.5.2.1.1 General criteria.

5.2.1.1.1 Selection. Criteria in Table 1 should be used in determining the type of control to be used on operator control panels. In addition, the following paragraphs should be consulted before deciding on specific control application.

5.2.1.1.1.1 Compatibility with users. The type of control selected and the location of the motion envelopes should assure that suitably-clothed and -equipped user personnel with applicable 5th through 95th percentile body dimensions and 5th percentile strength can operate them.

5.2.1.1.1.2 Distribution of load. Controls should be selected and distributed so that none of the operator's limbs will be overburdened.

5.2.1.1.1.3 Functional efficiency. Since more operators are right-handed than left-handed, a higher portion of operators will be more accurate, faster, and be able to apply more force with the right hand or foot than with the left; accordingly, equipment should generally be designed for right-handed operation.

- a. Hand manipulation is more precise than foot manipulation.
- b. More force usually can be applied by the foot and leg than by the hand and arm.
- c. Where right-hand manipulations could create difficulties for a left-handed operator, the control should be selected and located to minimize degradation for both left- and right-handed operators.
- d. Manipulator characteristics of candidate control devices should be compatible with operator biomechanical characteristics and limitations. For example, natural musculoskeletal motions, excursions, precision and strength factors should be considered in choosing the particular control device and locating it with respect to the operator.

5.2.1.1.1.4 Environmental and physical constraints. The considerations listed below should be considered in the selection, design, and placement of controls.

- a. Mobility constraints of special clothing (gloves, mittens), connections, electrical leads, and/or special restraint systems (seat belts).

MIL-HDBK-759B

TABLE 1. Control selection criteria

FUNCTION	CONTROL									
	Toggle Switch	Push Button	Bar Knob	Round Knob	Discrete Thumb wheel	Continuous Thumb wheel	Crank	Rocker Switch	Lever	Joystick, Ball, Mouse
Select power state ON-OFF	2	1	3					2	1*	
3-State (OFF-STBY-ON)	2		1					3		
Select between OFF/Prime Model Secondary Mode(s)	3	2	1					3	1*	
Select one or more of N related functions	2	1						2		
Select one of N mutually exclusive functions of any order		1								
Select one of 3-24 discrete alternatives - sequential order			1							
Select digit - discrete		1 Keybd	2**		2**					
Set value on - continuous scale				1		2	3		3	
Select value in - discrete steps		1	1		1					
Select operating condition	1	1	2					1	2	
Enter alphanumeric data		1 Keybd								
Initiate test subfunction (momentary)	1	1	3					2		
initiate directional function	1	2 Multiple	3			3		1 Multiple	1	
Generate stepping impulse (Momentary hold)	1	1						2		
Slew counters or other numeric readout	1	1		1 Rate Control			1 Manual Only			
Reset mechanical counter, manual				1	3	1				
Interrupt sequence, "hold"	2	1						2		
Engage - disengage mechanical function									1	
Adjust light level, cont.				1	3	1			3	
Adjust sound level, cont				1	3	1			3	
Coarse adjustment				1 Small Diam.		2 Small Motion	2 Few Turns		2 Short Throw	
Fine adjustment				1 Large Diam.		2 Large Motion	2 Many Turns		3 Long Throw	
Adjust to null position				1		2	3		3	
Single-coordinate tracking				3			2		1	
Two-coordinate tracking							3			1

*Lever for heavy duty power circuits.

**Only if sequential selection is acceptable.

(1 = most preferred, 3 = least preferred)

MIL-HDBK-759B

- b. Degrading effects of expected environments such as acceleration/ deceleration, vibration, ambient light, extreme cold, or extreme heat.
- c. Operator support and/or anchoring, for example, in order to apply required force to maintain a given control contact for the required duration and/or to have sufficient stability to perform a precise manipulation.

5.2.1.1.1.5 Basic factors in selection. Basic factors in selection include:

- a. the control's function, purpose, and importance to the system; the nature of the controlled object; the type of change to be made, as well as its extent, direction, and rate of change,
- b. the task's criteria (precision, speed, range, and force required to use the control) and how the system is affected by sacrificing one to improve another,
- c. the information the operator needs, including criteria for locating and identifying the control, determining its setting, and sensing any change in its setting,
- d. the amount and location of space where the control can be placed, and
- e. the importance of locating the control in a certain position for proper grouping or proper association with other controls and displays.

5.2.1.1.1.6 Force and range. When the primary considerations in selecting a control are its operating force and range of settings, use the recommendations in Table 2.

5.2.1.1.1.7 Precise adjustments. Hand-operated controls should be used for rapid or precise adjustments. When precise settings are required over a wide range, use multi-turn controls.

5.2.1.1.1.8 Detents. When the controlled object can be adjusted only within a limited number of discrete steps, discrete adjustment (detent controls) should be used rather than continuous adjustment (non-detent controls).

5.2.1.1.1.9 Stops. Stops should be provided at the beginning and end of the range of control positions if the control is not required to be operated beyond the indicated end positions or specified limits.

5.2.1.1.1.10 Standard practice. Unless demonstrable improvement in operator performance is shown by alternate concepts, standard practice relative to certain control-function utilization should be followed. Examples include the following:

- a. primary vehicle steering by a steering wheel,

MIL-HDBK-759B

TABLE 2. Recommended manual controls

Control function	Control type
<u>Small actuation force controls</u>	
2 Discrete positions	Keylock Push button Toggle switch Legend switch Slide switch
3 Discrete positions	Rotary selector switch Toggle switch Push button
4 to 24 Discrete positions	Rotary selector switch
Continuous setting (linear and less than 360°)	Continuous rotary knob Joystick or lever
Continuous slewing and fine adjustment	Crank Continuous rotary knob
<u>Large actuation force controls</u>	
2 Discrete positions	Foot push button Hand push button Detent lever
3 to 24 Discrete positions	Detent lever Rotary selector switch
Continuous setting (linear and less than 360°)	Handwheel Joystick or lever Crank Two-axis grip handle
Continuous setting (more than 360°)	Crank Handwheel Valve Two-axis grip handle

- b. three-dimensional vehicle steering/attitude control by a joystick or a combination joystick wheel and rudder pedals,
- c. primary vehicular braking by foot pedal(s),
- d. primary automotive acceleration by foot pedal,
- e. aircraft throttle control by manually-operated levers,
- f. automotive transmission gear position selection by a lever,
- g. continuous adjustment, panel control functions by rotary controls,

MIL-HDBK-759B

- h. discrete multi-position selection panel control functions by rotary selector switches, push buttons, or mechanically detented levers,
- i. multi-axis, console-type tracking function control by joystick, track ball and/or hand cranks,
- j. manual valve control by rotary knobs or T-handles (valves should have the word VALVE in their labels),
- k. simple two-position, panel control functions by push button, toggle, rocker, or slide switches.

5.2.1.1.1.11 Emergency controls. Emergency function controls should be located where they can be identified and reached quickly. However, their location should not be such that accidental use or inadvertent contact could result in serious system malfunction and/or ultimate injury to personnel.

5.2.1.1.1.12 Maintenance and adjustment. In general, controls used solely for maintenance and referred to infrequently should be covered during normal equipment operation but should be readily accessible and visible to the maintenance technician when required.

5.2.1.1.2 Control movement characteristics.

5.2.1.1.2.1 Stereotypes. Where most users expect to find standard stereotyped relationships between controls and displays, these expectancies should be followed to take advantage of previous learning, maximize transfer of training, and minimize error (see Table 3)

5.2.1.1.2.2 Direction-of-motion expectancy. Expected control-system motion relationships should be observed in the design, selection and/or arrangement and positioning of controls. Among these are the following:

TABLE 3. Conventional control movement stereotypes

Direction of Movement	Function
Up, right, forward, clockwise, pull (push-pull type switch)	On
Down, left, rearward, counterclockwise, push	Off
Clockwise, right	Right
Counterclockwise, left	Left
Up, back	Raise
Down, forward	Lower
Up, rearward, pull	Retract
Down, forward, push	Extend
Forward, up, right, clockwise	Increase
Rearward, down, left, counterclockwise	Decrease
Counterclockwise	Open Valve
Clockwise	Close Valve

MIL-HDBK-759B

- a. Rotary controls are expected to rotate clockwise to effect an increasing function. Valve controls are excepted (see c, below).
- b. A lever is expected to move forward up or to the right for an increasing function but down or to the rear to apply a braking action.
- c. A rotary valve control is expected to rotate counterclockwise to increase line flow such as liquid flow. A double-ended arrow labeled OPEN in the CCW direction and CLOSE in the CW direction should be used to identify movement relationships.
- d. Depressing an accelerator pedal is expected to increase a vehicle's speed.
- e. A brake pedal is expected to be depressed to cause braking.

5.2.1.1.2.3 Control-display motion. The following combination motion relationships should be observed:

- a. In general, a right, clockwise, forward or upward control motion should result in clockwise, right, or upward motion of the moving element of an associated display (instrument pointer), except for certain aircraft control/display combinations ("fly-to" principle for joystick/aircraft direction and attitude displays) and valve/display combinations (counterclockwise valve rotation results in a clockwise or upper pointer motion on a pressure gauge).
- b. Although not preferred, when a numerical scale used on a rotary control skirt is to be set against a fixed-index marker, the clockwise rotation of the knob should result in increasing scale values (the scale should be designed so that values increase in a counterclockwise direction around the knob skirt).

5.2.1.1.2.4 Control-device motion. When a control affects the movement of some appended device which is directly observable by the operator (window, windshield wiper, remotely-controlled object such as a crane boom and tackle or hook), the motion of the control and the controlled object should be similar.

5.2.1.1.2.5 Control-vehicle motion relationships. The control-vehicle motion relationships listed below should be observed:

- a. Ground vehicles. Standard vehicle control convention should be observed with respect to automotive and similar vehicles: (1) clockwise motion of the steering wheel results in a right turn; (2) forward movement of the accelerator results in increase in speed; (3) forward movement of service or parking brake pedals results in slowing and/or stopping of vehicle; (4) rearward (pull) motions of a hand brake result in slowing or stopping of vehicle; or (5) upward motion of column-mounted turn-signal lever results in activation of right turn-signal light. When a rotary knob is used on the end of column-mounted levers, forward rotation of the knob as viewed from above should produce an increasing function for either side of the steering wheel. However, the concept of clockwise for increase does not hold for the left-hand knob.

MIL-HDBK-759B

- b. Aircraft, spacecraft, and submersibles. A forward movement of any lever control normally should result in an increase in aircraft performance (addition of engine power or trimming for increased speed). Exceptions include the joystick (which moves aft to raise the nose of the aircraft; to the right for a right turn or right roll). For all aircraft control conventions refer to MIL-STD-203 and MIL-STD-250.
- c. Tracked vehicle steering. Because of independent drive systems typically used in tracked vehicles, steering control (lever) movements should follow the convention of forward lever movements to drive the associated track. A combination of right control lever forward with left control lever aft should produce a left turn and vice versa.
- d. Marinecraft steering. Clockwise movement of a wheel should result in a right turn of the vessel. A right movement of a tiller control should result in a left turn of a small boat.

5.2.1.1.2.6 Proportional controls. It is permissible to make control action disproportionately rapid where settings are not critical or disproportionately slow where personnel should make fine adjustments. With proportional controls, including engine throttles, the action of the device that is controlled should parallel the force and movement applied to the control.

5.2.1.1.3 Arrangement and grouping.

5.2.1.1.3.1 Primary controls. The most important and frequently used controls should have the most favorable positions with respect to ease of reaching and grasping (particularly rotary controls and those requiring fine settings).

5.2.1.1.3.2 Functional grouping. All controls which operate sequentially to accomplish a particular task, or which operate together, should be grouped together along with their associated displays. When several steps of a sequence are selected by one control, the steps should be arranged by order of occurrence to minimize control movements and prevent cycling through unnecessary steps. Cycling through the control's ON/OFF position should be avoided.

5.2.1.1.3.3 Sequential grouping. Controls may be combined to aid sequential or simultaneous operation, to reduce reaching, or to save space. However, designers should minimize the possibility of accidental operation.

5.2.1.1.3.4 Consistency. When functionally similar control interfaces appear in more than one operator station within the same or similar systems, control locations and arrangements should also be the same or at least similar.

5.2.1.1.3.5 Remote controls. Where controls are operated at a position remote from the display, equipment, or vehicle controlled, control arrangement should be established to facilitate direction-of-movement consistency.

MIL-HDBK-759B

TABLE 4. Minimum separation distances for panel-mounted controls

	Toggle Switches	*Push buttons	Continuous rotary controls	Rotary selector switches	Discrete thumbwheel controls
Toggle switches	See Table 15	13 mm	19 mm	19 mm	13 mm
*Push buttons		See Table 10	13 mm	13 mm	13 mm
Continuous rotary controls	19 mm	13 mm	See Table 14	25 mm	19 mm
Rotary selector switches	19 mm	13 mm	25 mm	13 mm	19 mm
Discrete thumbwheel controls	13 mm	13 mm	19 mm	19 mm	See Figure 19

*For push buttons not separated by barriers.

NOTE: All values are for one-hand operation. Distances are measured in mm and are measured at the closest point of approach for each pair of controls as they are moved throughout their entire range of movement.

5.2.1.1.3.6 Spacing. Minimum spacing between controls should comply with Table 4.

5.2.1.1.4 Coding. Many methods of coding are available. should be based on such factors as those listed below:

- a. types of coding already being used,
- b. kinds of information to be used,
- c. nature of the tasks to be performed, and the conditions under which they will be performed,
- d. number of coding steps or categories available (the number of different knob shapes available, and how many of those shapes users can discriminate easily),
- e. need for redundant or combination coding, and
- f. standardizing coding methods.

MIL-HDBK-759B

Any coding method that is selected should be used consistently and with consistent meaning throughout the system. Consideration should be given to consistency of coding used within a system compared to coding used in other systems which the operator may be employing (either separately from, or in conjunction with, the system being designed). The method should allow controls to be identified easily by sight or touch and discriminated from each other by color, size, shape, and location.

5.2.1.1.4.1 Color.

5.2.1.1.4.1.1 Ambient light. Color coding requires unrestricted vision, as well as reasonably bright, whitish ambient light for colors to be easily discriminable from each other. This type of coding should not be used when visibility is restricted or obstructed, or when the illumination is dim, or under colored light.

5.2.1.1.4.1.2 Related controls. When related controls and displays are color coded, they should be coded the same color.

5.2.1.1.4.1.3 Emergency controls. All emergency controls should be coded red. To give these emergency controls the visual emphasis they demand, only a bare minimum of other, less important controls should be color coded. Colors used to code critical controls should contrast sharply with those used for non-critical controls.

5.2.1.1.4.1.4 Selection of colors. While it may be necessary to tailor selection of colors to specific applications, the colors shown in Table 5 are readily available standard colors and should be considered for control coding before any radical departure is contemplated.

5.2.1.1.4.1.5 Control-panel contrast. Control colors should contrast with the panel on which the controls are mounted.

5.2.1.1.4.2 Shape.

5.2.1.1.4.2.1 Desire coding. The primary reason for shape coding controls is to facilitate identification by feel. However, shapes should be identifiable both visually and tactually. When shape coding is used, the coded feature should not interfere with the ease of control manipulation. Shapes should be equally identifiable by feel regardless of the position of the control knob or handle. (See 5.2.1 .6.6 for easily recognizable knob shapes.) Shape as a coding parameter should be used only after considering the concepts listed below.

- a. If the control should be operated with the gloved or mittened hand, proposed shapes are identifiable when such handwear is worn.
- b. There are a sufficient number of identifiable shapes to cover the expected number of controls that require tactile identification.

MIL-HDBK-759B

- c. The control knobs or handles to be shape-coded lend themselves to positive, non-reversible attachment. (When a replacement is required, it is impossible to attach the new knob in an 'orientation-that may be obscured from, or confusing to, the operator.)

TABLE 5. Recommended control colors (FED-STD-595)

Use	Color	Gloss	Semi-gloss	Flat
Standard	Black	17038	--	
	Gray	--	26231	
	Green	14187		--
	Orange-Yellow	13538	23538	33538
	White	17875	27875	37875
Supplement to standard if required	Blue	15123	--	--
Emergency	Red	11105	21105	31105

5.2.1.1.4.2.2 Similar functions. Controls with similar purposes or functions should have the same shape.

5.2.1.1.4.2.3 Dimensions. When operators should distinguish controls by touch alone, the shape of the control should be free of sharp edges or corners and at least:

- a. Height: 13 mm or larger
- b. Width: 13 mm or larger
- c. Depth: 6.5 mm or larger

5.2.1.1.4.3 Size.

5.2.1.1.4.3.1 Discrimination of sizes. When coding controls by size, it is important to make sure sizes differ enough that users are not likely to confuse them. Users can learn to discriminate two or three different sizes of controls; if more coding steps are needed, another coding system should be used. When size coding knobs with diameters between 13 mm and 100 mm, each knob's diameter should be at least 20% larger than the next smaller one.

5.2.1.1.4.3.2 Similar functions. Code sizes should be consistent when controls have similar functions on different items of equipment.

MIL-HDBK-759B

5.2.1.1.4.3.3 Sub-coding. Size-coded knobs may also be sub-coded by shapes, since within the size range indicated in 5.2.1.1.4.2.3, users can recognize shapes regardless of their size.

5.2.1.1.4.4 Location.

5.2.1.1.4.4.1 General. When operators cannot see controls, but should operate them by blind positioning, the most effective coding method is by location.

5.2.1.1.4.4.2 Spacing. Operators discriminate locations more accurately when controls are in front of them. Controls in the forward area should be spaced about 150 to 200 mm apart. When controls are beside (or behind) the operator, they should be 300 to 400 mm apart, for easy recognition without confusion.

5.2.1.1.5 Labels.

5.2.1.1.5.1 General. Controls should have labels (on panel or control) that identify what they control and show how to operate the control. Some equipment manufacturers are developing uniform symbols for use with controls. Uniform symbols, which have been standardized and accepted, may be used in lieu of labels.

5.2.1.2 Design characteristics.

5.2.1.2.1 General. Design characteristics for controls are described in Figures 1 through 24. Selection should not necessarily be limited to the controls shown in this section. The illustrations show recommended dimensional, displacement, and force characteristics.

5.2.1.3 Hand cranks.

5.2.1.3.1 General. Cranks should be used primarily when the control should be rotated many times, particularly where high rates or large forces are involved. For tasks involving large slewing movements, plus small, fine adjustments, a crank handle may be mounted on a knob or handwheel--the crank for slewing and the knob or handwheel for fine adjustments. Where cranks are used for tuning, or other processes involving numerical selection, each rotation should correspond to a multiple of 1, 10, or 100. Simultaneously-operated hand cranks should be used in preference to other two-axis controllers where extreme precision is required in setting cross hairs or reticles as in map readouts or optical sighting mechanisms. This type of control may also be used in other applications requiring X-Y control provided there is no requirement for rapid or frequent operation. The gear ratio and dynamic characteristics of such cranks should allow precise placement of the follower (cross hairs) without overshooting or undershooting and successive corrective movements. Basic crank dimensions are shown in Figure 1.

5.2.1.3.2 Handles. Handles should be used to maximize the area of contact with the hand. They should turn about their shafts freely. The outside edge of the crank handles should clear any obstruction by at least 75 mm.

MIL-HDBK-759B

5.2.1.3.3 Positioning of cranks. Cranks which must be turned rapidly should be mounted so their turning axes are between 60° and 90° from the body's frontal plane (Figure 2). For standing operators, they should be between 900 and 1200 mm above tie-floor.

5.2.1.4 Handwheels.

5.2.1.4.1 Application. Handwheels, which are designed for nominal two-hand operation, should be used when the breakout or rotation forces are too high to be easily overcome with a one-handed control, provided that two hands are available for this task. Typical applications to be considered are steering, hatch securing, valve opening/closing, and hatch-locking handwheels.

5.2.1.4.2 Direction of movement. Handwheel direction of movement should conform to the guidelines in 5.2.1.1.2. For all handwheels in which the direction of motion relationship is not directly apparent (expectation), direction of motion should be indicated directly on the wheel rim and/or immediately adjacent thereto on a panel or structural surface, using appropriate labeling and/or directional arrows.

5.2.1.4.3 Dimensions, resistance, displacement, and separation. Control dimensions, resistance, displacement, and separation between adjacent handwheels should conform to criteria in Table 6.

5.2.1.4.4 Position. Handwheels (including steering wheels) should be selected in terms of size and expected usage to provide operator use convenience based upon whether the operator is seated or standing to operate the wheel. For seated operation, the wheel should normally be centered on the operator's centerline and sloped so that both of the operator's arms and hands have approximately equal access to the wheel. In addition, wheels operated from the seated position should be sized and positioned for convenient ingress/egress as well as over-the-wheel viewing, where applicable (see 5.8.4.17.1 for vehicle applications).

MIL-HDBK-759B

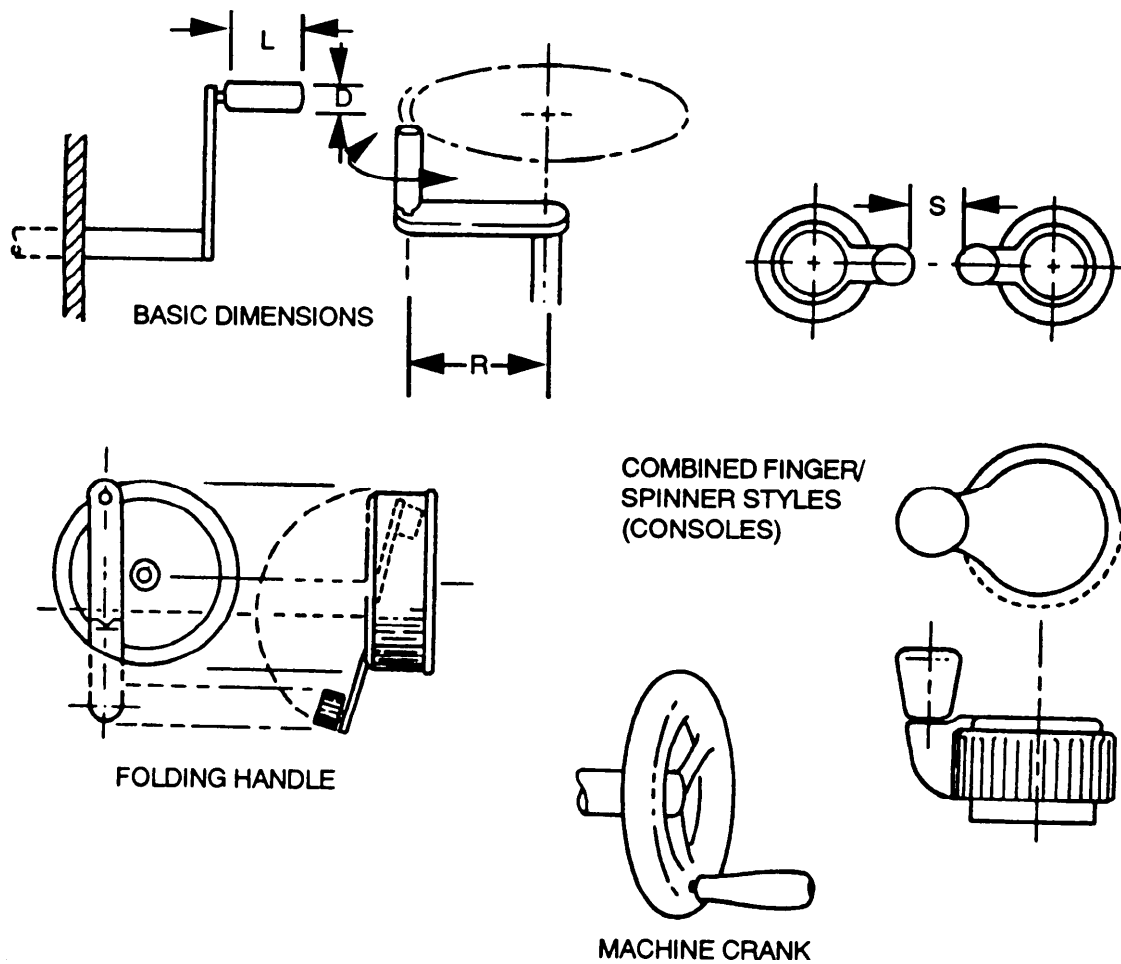

LOAD	SPECIFICATION	Handle		R, turning radius	
		L, LENGTH	D, DIAMETER	RATE BELOW 100 RPM	RATE ABOVE 100 RPM
					mm
Light loads:	MINIMUM	25	9.5	38	13
Less than 2.27 kg	PREFERRED	38	13	75	58
(Wrist and finger movement)	MAXIMUM	75	16	125	115
Heavy loads:	MINIMUM	75	25	190	125
more than 2.27 kg	PREFERRED	95	25	.	
(arm movement)	MAXIMUM	-	38	510	230

S, SEPARATION BETWEEN ADJACENT CONTROLS: 75 mm MINIMUM.

FIGURE 1. Cranks

MIL-HDBK-759B

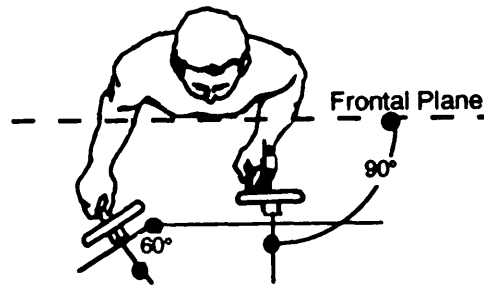

FIGURE 2. Proper mounting of rapidly operated crank

5.2.1.4.5 Spinner handles. For applications where the wheel may be rotated rapidly through several revolutions (slewing), a spinner handle may be added for convenience. However, such handles should not be used if the projecting handle is vulnerable to inadvertent displacement of a critical wheel setting or is a safety hazard.

5.2.1.4.6 Turning aids. Knurling, indentation, and/or high-friction cover may be built into the handwheel to facilitate operator grasp for purposes such as applying maximum torque and/or to reducing the possibility of the wheel being jerked out of the operator's hands.

5.2.1.4.7 Wheel hub delethalization. Steering wheel hubs should be recessed and provided with a broad pad to minimize the possibility of driver impalement during a crash. Consideration should also be given to use of a collapsible steering column for rapidly-moving vehicles. Such steering wheels should be structurally resistant to major rim/spoke distortion considering the loads that could be created by the driver's body being thrust into the wheel during a crash.

5.2.1.4.8 Steering wheel shape. Except for established uses in armored combat vehicles, aircraft, and other applications where maximum wheel deflection does not exceed 120°, all steering wheels should be round.

5.2.1.4.9 Power steering failure. Steering systems should be designed with sufficient mechanical advantage to meet the force criteria of Table 6, even though the primary operating mode utilizes power-assist. The operator should be able to steer the vehicle to a safe stop in the event of power failure.

5.2.1.4.10 Steering ratio. Steering systems should be designed so that the maximum turning limits of the vehicle can be acquired by no more than 3.5 turns of the steering wheel.

MIL-HDBK-759B

TABLE 6. Handwheels





APPLICATION CRITERIA	DESIGN CRITERIA					SEPARATION
	DIMENSIONS			DISPLACEMENT	MIN HAND CLEARANCE	
	DIAMETER	RIM DIAMETER	RIM DIAMETER			
 <p>CONTINUOUS ADJUSTMENT FOR ALTERNATE SLEWING/PRECISE POSITIONING, USING DISPLAY REFERENCE. RESISTANCE LOW (BELOW 11.25KG)</p>	200-500 mm	19-32 mm	75 mm AROUND RIM		710 mm ELBOW-ELBOW CLEARANCE	
 <p>CONTINUOUS LOCK-UNLOCK OPERATION</p>	200 mm FOR 22 N TO 510 mm FOR 220 N	19-32 mm	75 mm AROUND RIM	N/A	710 mm ELBOW-ELBOW CLEARANCE	
 <p>HIGH TORQUE VALVES</p> 	200-400 mm FOR OVERHEAD; 200-510 mm FOR OTHER POSITIONS; 300 mm-1.5 m ABOVE STANDING SURFACE	19-32 mm	75 mm AROUND RIM		710 mm ELBOW-ELBOW CLEARANCE	

TABLE 6. Handwheels - continued

APPLICATION CRITERIA		DESIGN CRITERIA			DISPLACEMENT	SEPARATION
		DIMENSIONS		S, SLOPE		
D, DIAMETER	R _d , RIM DIAM	S, SLOPE				
<p>VEHICLES STEERING (AUTOMOTIVE) MAX RESISTANCE POWER STEERING</p> <p>MAX NON-POWER = 220 N</p>		<p>355-400 mm FOR POWER STEERING</p> <p>400-510 mm FOR NON-POWER STEERING</p>	<p>19-32 mm</p>	<p>30° FOR LIGHT VEHICLE (PREFERRED)</p> <p>45° FOR HEAVY VEHICLE (PREFERRED)</p>	<p>MAX = 120° WHEN BOTH HANDS MUST REMAIN ON WHEEL</p>	<p>N/A</p>
<p>AIRCRAFT STEERING (COMBINE WITH LEVER FOR PITCH, RUDDER PEDALS FOR ROLL/STEER)</p>		<p>D, GRIP DIAMETER 19 mm PREFERRED</p>	<p>L, GRIP LENGTH 100 mm MINIMUM</p>	<p>X-Y GRIP TILT X = 15° Y = 0-15° PREFERRED</p>	<p>+/- 30° MAX PREFERRED</p>	<p>N/A</p>

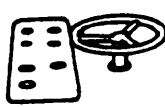
MIL-HDBK-759B

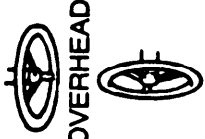
5.2.1.5 Keylocks and keylock switches.

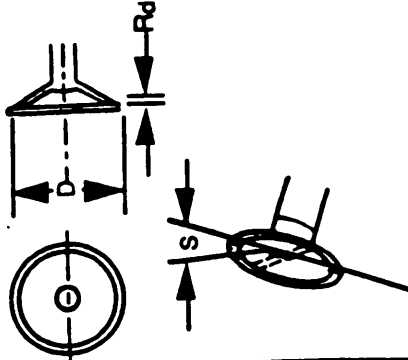
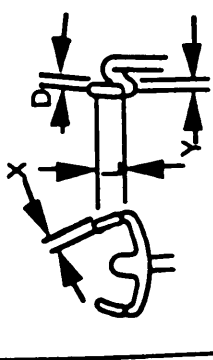
5.2.1.5.1 Keylocks. Keylocks used solely to lock and unlock doors, cabinets, covers or drawers should conform to the conditions listed below.

- a. Key position and motion relative to locking and unlocking should conform to criteria in Figure 3.
- b. Key dimensions, separation, and resistance should conform to criteria in Figure 4.
- c. Reversible key designs should be used. It is preferable to have keys that will operate the lock with either side "up". If key designs are used that have teeth only on one side, the lock should be oriented so that the "flat" edge of the key will be on the bottom to enter a vertical (lock) slot, and to the right to enter a horizontal (lock) slot.
- d. Lock systems used for vehicle exterior doors should be designed so that the operator cannot inadvertently lock himself out of the vehicle.
- e. Keylocks exposed to external weather conditions should be weatherproof. They should not become inoperable because of dirt accumulation nor freeze because of moisture collection and freezing temperatures.
- f. When several keylock systems are required on the same vehicle or equipment, and all locks should be accessible to the operator, a single key and identical locks should be used. On the other hand, when access to certain closures should be limited to people other than the operator, different keylock assemblies should be used so that the operator's key will not unlock these special locks.

5.2.1.5.2 Keylock switches. Keylock switches which are used not only to provide security (by removing the key), but also to provide ON-OFF functions, should conform to the conditions listed below.

- a. Key should be removable only in the security position.
- b. Key position and motion relative to locking, unlocking, and ignition should conform to criteria in Figure 5.
- c. Key dimensions, separation, and resistance should conform to criteria in Figure 4.

MIL-HDBK-759B

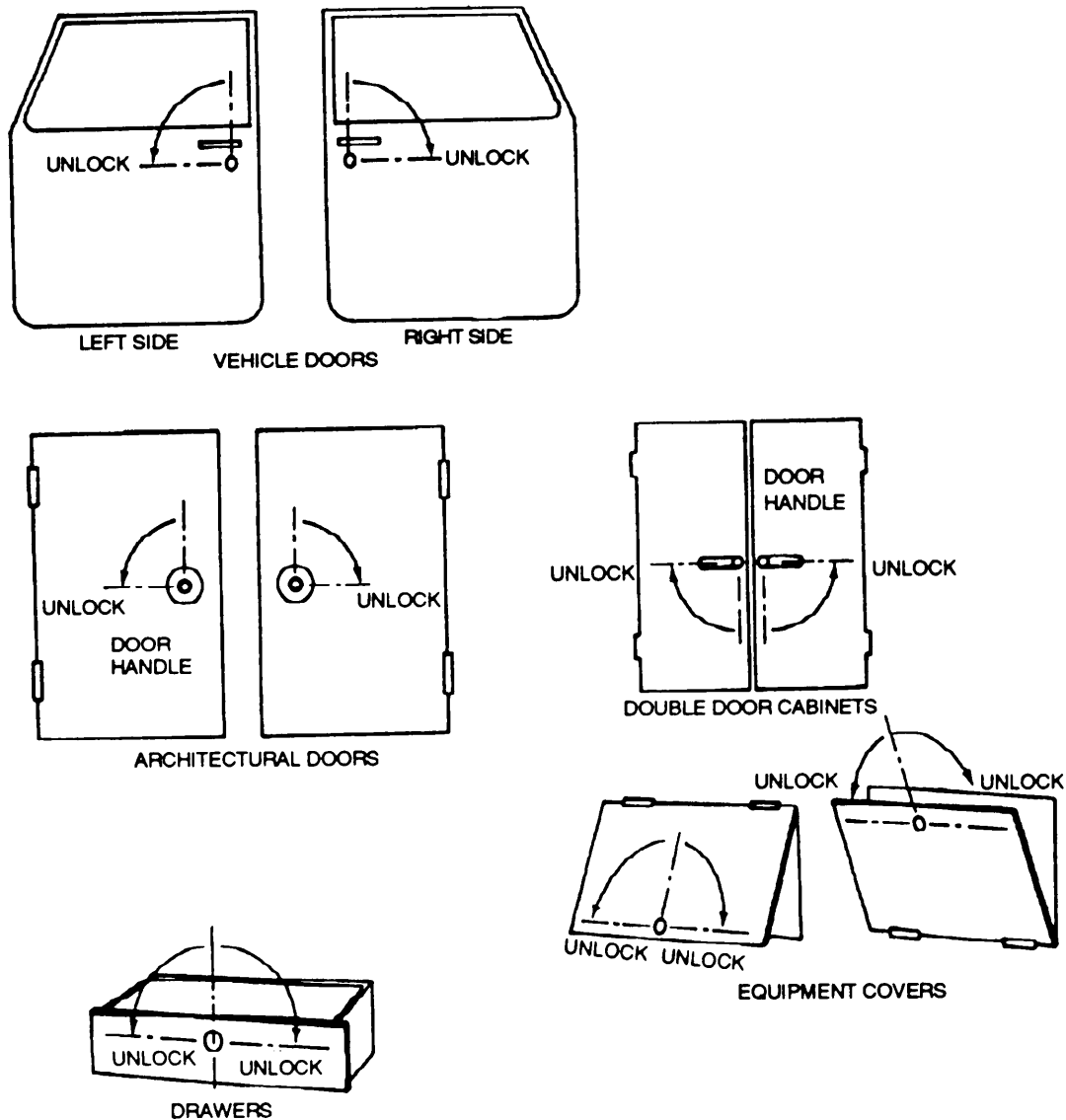
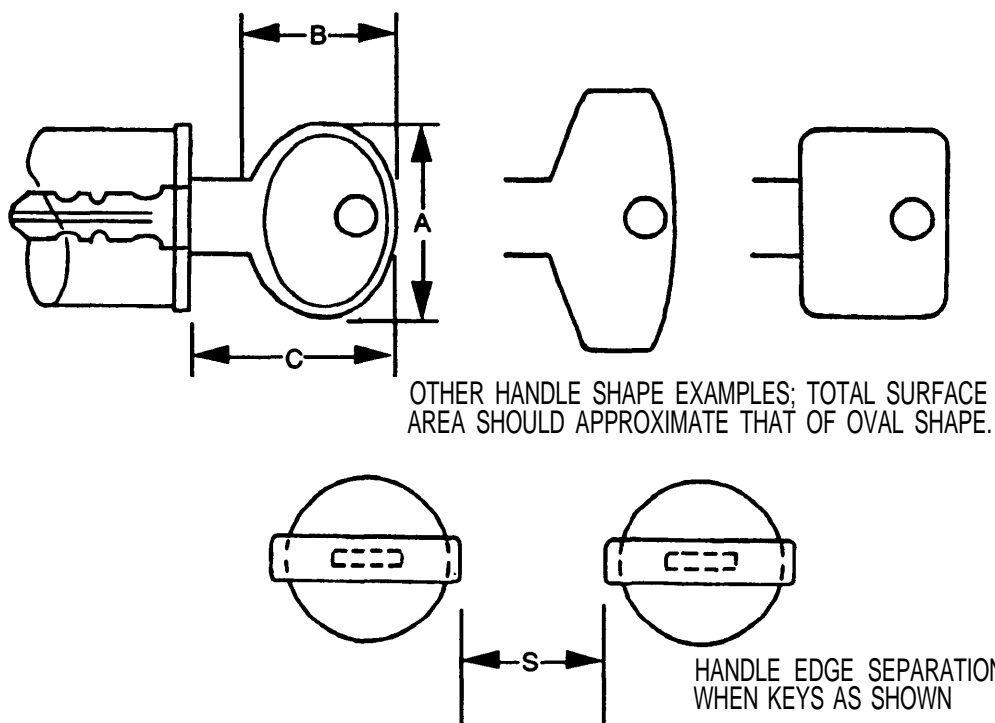

FIGURE 3. Keylock mounting criteria

- d. Key designs should conform to criteria in 5.2.1.5.1.c.
- e. Keylock switches that will be used externally should be weatherproofed to prevent failures resulting from dirt and freezing.
- f. An auditory signal should be provided for vehicle ignition keylock systems to advise the operator that the key has been left in the ignition lock after the engine has been shut off.

MIL-HDBK-759B



	A	B	c	S-SEPARATION	RESISTANCE*
MINIMUM	13mm	13mm	20mm	25mm	0.1 N-m
MAXIMUM	75 mm**	38 mm**	--	25mm	0.7 N-m

* When locks are new.

**Practical for carrying key in pocket.

FIGURE 4. Keylock criteria

5.2.1.5.3 Color, shape and size coding. Color, shape, and size coding should be considered in conditions listed below.

- Color may be used to aid in identifying keys by function or use location, where illumination is adequate to differentiate the colors. RED should be reserved for emergency functions (FED-STD-595, # 11105 or # 21105).
- Shape coding may be used to aid in tactile identification of a given key. When shape coding is used, sharp corners should be avoided.
- Size coding may also be used as long as no more than two sizes are employed. The dimensions should reflect the approximate differences between minima and maxima shown in Figure 4.

MIL-HDBK-759B

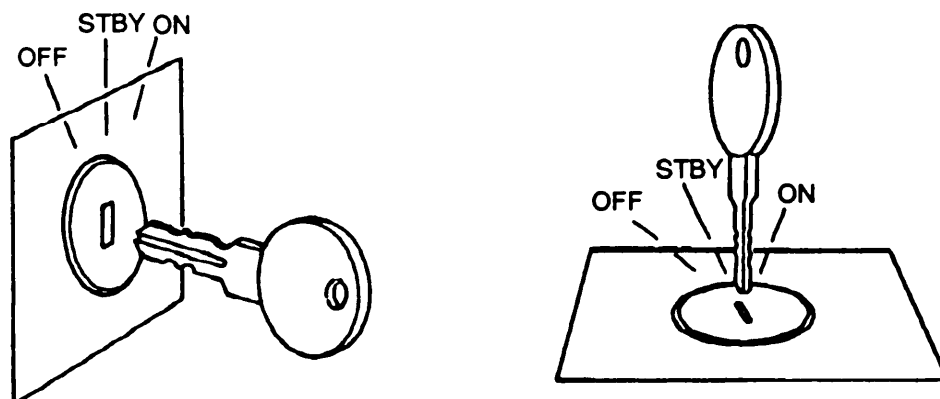

PANEL - MOUNTED SWITCHES

NOTES:

1. Switchlocks should generally be oriented so that the pivotal off key position is vertical and/or forward (horizontal panel).
2. Key displacement between functional positions should be at least 30°. Mechanical detents should preclude positioning the key in between designated positions.
3. When only two functional positions occur (on-off), displacement between the two positions should be 90°.
4. Total displacement of multi-position keylock switches should not exceed 120°.

FIGURE 5. Keylock switch criteria

MIL-HDBK-759B

5.2.1.5.4 Marking and labeling. Keylock switch applications should include appropriate positional markings and labels.

5.2.1.6 Knobs.

5.2.1.6.1 Application. Knobs should be used when low forces or precise adjustments of a continuous variable are required. If the adjustment requires reference to a scale, the scale should be placed on a panel and an index line should be inscribed on the pointer (moving-pointer/fixed-scale format). If the range of knob movement involves more than 360° rotation, scales should not be used, except for directional input devices (azimuth setting).

5.2.1.6.2 Dimensions, torque, and knob separation. The dimensions of knobs should be within the limits specified in Figure 6. Within these ranges, knob size is relatively unimportant, provided resistance is low and the knob can be easily grasped and manipulated. When panel space is extremely limited, knobs should approximate the minimum values and should have resistance as low as possible, but sufficient to minimize inadvertent control position disturbance attributable to equipment vibration or accidental touching of the control knob. Torque and separation between adjacent edges of knobs should conform to Figure 6.

5.2.1.6.3 Direction of movement. Turning a knob clockwise should produce an increase. A circular arrow should be drawn beside the knob to indicate the direction of increase (see Figure 7).

5.2.1.6.4 Knobs mounted with set screws. Control knobs should be mounted with large set screws which are accessible enough to be tightened or loosened with a standard-size screwdriver. Selection of a switch, with regard to location of the set screw (Figure 8), is a function of access to the set screw in the installed position. If control resistance is substantial (selector switches with several contact discs), minimize the possibility of knobs slipping on their shafts by using knobs with two set screws, spaced about 90° apart.

5.2.1.6.5 Shapes. Knobs which perform the same function should have the same shape. The shape should be determined by the knob's function and use. Representative knob shapes are shown in Figure 9.

5.2.1.6.6 Tactile (touch) recognition. For knobs that should be recognized by touch alone, use easily recognizable knob shapes (see Figure 10). Some sets of knobs have been specially developed and validated experimentally for tactile recognition (see Figure 9).

MIL-HDBK-759B

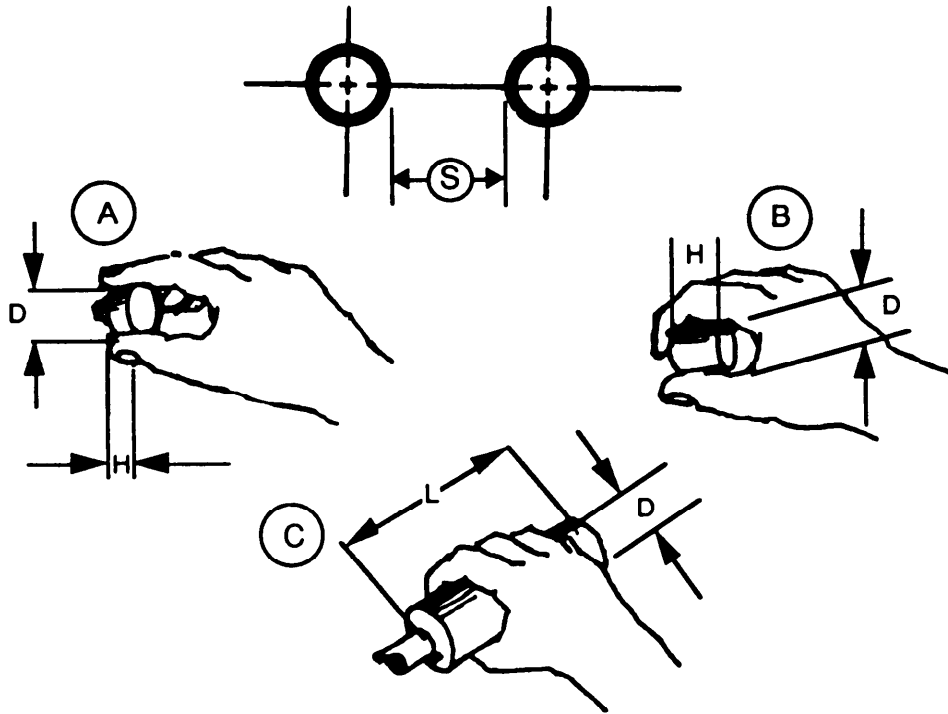

	A Fingertip Grasp		B Thumb and Finger Encircles		C Palm Grasp	
	H Height	D Diameter	H Height	D Diameter	D Diameter	L Length
Minimum	13 mm	10 mm	13 mm	25 mm	38 mm	75 mm
Maximum	125 mm	100 mm	25 mm	75 mm	75 mm	--

	S Separation		Torque	
	One Hand Individually	Two Hands Simultaneously	*	**
Minimum	25 mm	75 mm	--	--
Optimum	50 mm	125 mm	--	--
Maximum	--		32 mN•m	42 mN•m

*Up to/including 25 mm diameter.

**Greater than 25 mm diameter.

FIGURE 6. Knobs

MIL-HDBK-759B

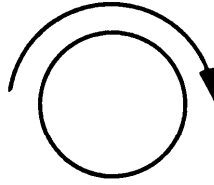

FIGURE 7. Knob Rotation

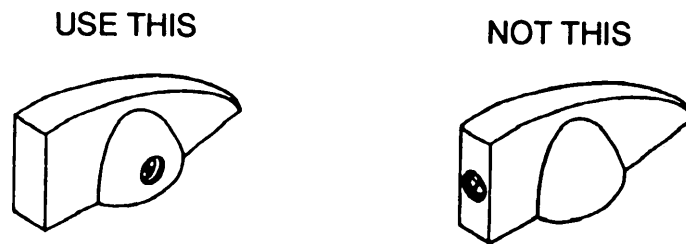
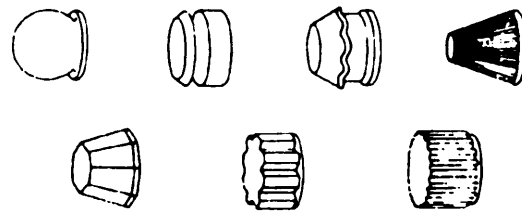
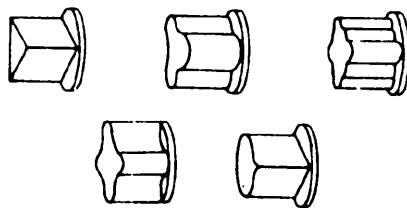

FIGURE 8. Set screws for control knobs



(A) KNOBS FOR MORE THAN ONE FULL TURN



(B) KNOBS FOR LESS THAN ONE FULL TURN

FIGURE 9. Recommended knob shapes

MIL-HDBK-759B

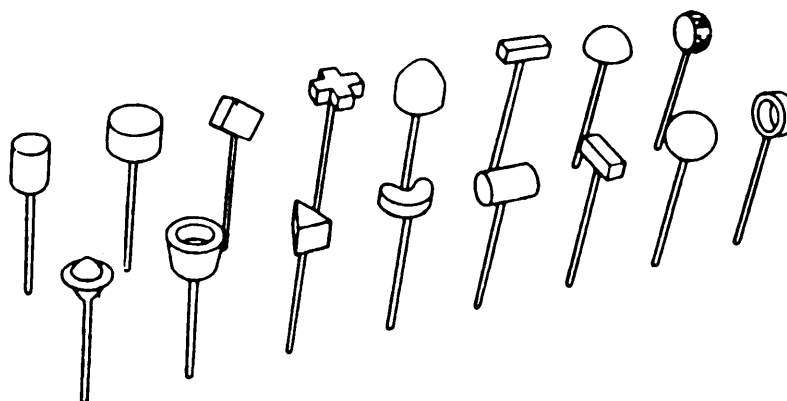

FIGURE 10. Easily recognizable knob shapes

5.2.1.6.7 Knob rims. All rotary adjustment knobs should have rims with suitable surfaces for secure grasp. Very small knobs should have knurled surfaces to provide maximum torquing capability. Intermediate and larger sizes of knobs should have serrated rims, except that knobs used where high torque is required should have rim indentation rather than serration for firmer grasp. Larger knobs should utilize rim indentation to aid gripping for application of higher torques. The design should ensure that the operator will not injure a hand if the shaft sticks.

5.2.1.6.8 Twist grip controls. Handle-like rotary controls may be used for special applications (motorcycle accelerator control), in which case dimensional criteria shown for value C in Figure 6 should be observed.

5.2.1.6.9 Contact hazard. When knobs are used in vehicles and are located where they could be contacted during the sudden deceleration of a crash, frontal surface area should be large, and all edges should be rounded in order to minimize the potential injuries associated with small, sharp, knob designs.

5.2.1.6.10 Ganged control knobs.

5.2.1.6.10.1 Application. Ganged knob assemblies may be used in limited applications when panel space is at a premium. Two-knob assemblies are preferred, although three-knob configurations are permissible. Ganged knob configurations should not be used when extremely accurate or rapid operations are required, frequent changes are necessary, gloves have to be worn, equipment is exposed to the weather or used under rough field conditions.

5.2.1.6.10.2 Dimensions and separation between assemblies. Knob dimensions and separation should conform to criteria in Figure 11.

5.2.1.6.10.3 Resistance. Knob resistance should conform to criteria in Figure 11. Knobs should be serrated; fine serrations should be used on knobs used to make fine adjustments, and coarse serrations should be used on knobs used to make less fine adjustments.

MIL-HDBK-759B

5.2.1.6.10.4 Marking. An indexing mark or pointer should be provided on each knob in an assembly. Marks or pointers should differ sufficiently to make it apparent which knob indexing mark is being observed.

5.2.1.6.10.5 Knob/display relationship. When each knob of a ganged assembly should be related to an array of visual displays, the lower knob should relate to the left-most display in a horizontal array, or the uppermost display in a vertical array.

5.2.1.6.10.6 Inadvertent operation. When it is critical to prevent inadvertent activation of one knob as the other is being adjusted, a secondary control movement should be required (pressing the top knob before it can be engaged with its control shaft). Where inadvertent movement is undesirable but not necessarily critical, optimize knob diameter/depth relationships as shown in Figure 11. Contrasting colors between knobs may also be used to improve individual knob identification.

5.2.1.7 Legend switches.

5.2.1.7.1 Uses. Legend switches are particularly well-suited to the conditions listed below:

- a. To display qualitative information on an important system status which requires the operator's attention.
- b. To reduce demands for the operator to interpret information.
- c. When functional grouping or a matrix of control switches and indicators is required but space is very limited.

5.2.1.7.2 Characteristics. The following characteristics apply to legend switches:

- a. Legend switches should be located within a 30° cone along the operator's normal line of sight.
- b. For positive feedback that the switch has operated, legend switches should have a detent or a click.
- c. Legend switch lamps should be replaceable from the front of the panel.
- d. Legends should be legible with or without internal illumination.
- e. If legend switches do not have duplicate bulbs, dual filament, or equivalent reliability, the legend switch circuit should permit a positive test of the lamp.
- f. The minimum and maximum dimensions for legend switches are shown in Figure 12.

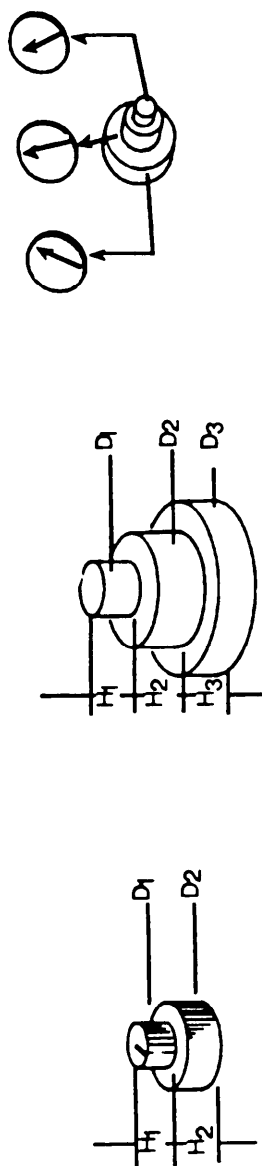

Ganged Knob/Display Association

		Dimensions									
		Two-Knob Assembly			Three-Knob Assembly						
		H1	H2	D1	D2	H1	H2	H3	D1	D2	D3
Minimum		16 mm	13 mm	13 mm	22 mm	19 mm	19 mm	6.5 mm	13 mm	44 mm	75 mm
Maximum					100 mm						100 mm

	Torque	Separation			
		One Hand Individually		Two Hands Simultaneously	
	*	Bare	Gloved	Bare	Gloved
Minimum		25 mm	65 mm	50 mm	90 mm
Optimum		50 mm	90 mm	75 mm	100 mm
Maximum	32 mN•m				
	42 mN•m				

*To and including 25 mm diameter knobs

**Greater than 25 mm diameter knobs

FIGURE 11. Ganged Knobs

MIL-HDBK-759B

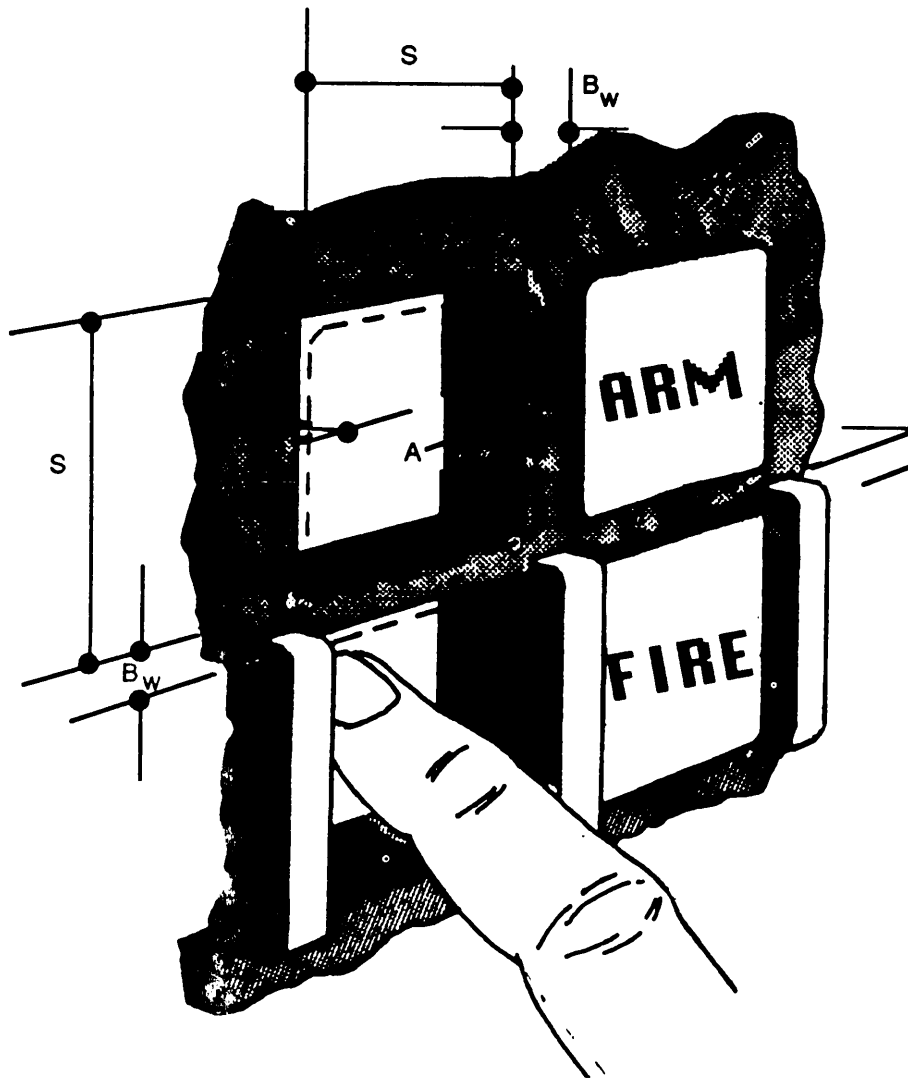

	Size S	Displacement A	Barriers*		Resistance
			Bw	Bd	
Minimum	19 mm**	3 mm***	3 mm	6 mm	2.8N****
Maximum	38 mm	6 mm	6 mm	6 mm	16.7N

*Barriers should have rounded edges.

**15 mm where switch is not depressed below the panel.

***5 mm for positive position switches

****5.6N for use in moving vehicles.

NOTE: Bw refers to barrier width and switch separation. Bd refers to barrier depth.

FIGURE 12. Legend switch

MIL-HDBK-759B

5.2.1.8 Levers.

5.2.1.8.1 Application. Lever-type controls may be used, when large forces or displacements are involved, as an alternate control for electrical switching when it may be more cost-effective to provide direct mechanical linkage between the control and controlled element, or when multi-dimensional, mechanical or electro-mechanical, multi-stage control modes (gear shift) are required. Lever-type controls should not be used where very precise electrical outputs are required (in lieu of a precision electrical adjustment, where a rotary controller is more appropriate). Levers should be considered for the general classes of control listed below:

- a. braking (mechanical)
- b. mode selection (environmental system)
- c. gear selection (vehicle/machine transmission)
- d. gross, continuous adjustment (temperature, audio volume, throttle)
- e. steering (joystick, track vehicle)

5.2.1.8.2 Location, position, direction, and range of movement. The location, position relative to the operator, and direction and range of lever movement should be compatible with operator reach, mobility, natural movements, and strength capabilities. In addition, direction of motion criteria noted in 5.2.1.1.2 should be observed. When high forces are required of the operator, the lever handle should be located between waist and shoulder levels, and the force should normally be applied in a pulling direction.

5.2.1.8.3 Limb and body support. When levers will be used to make fairly precise or continuous adjustments, support should be provided for the appropriate limb segment as follows:

- a. for large hand movements, support the elbow,
- b. for small hand and wrist movements, support the forearm, and
- c. for finger movements, support the wrist.

5.2.1.8.4 Resistance. The resistance incorporated in levers should be within the limits indicated in Table 7 (measured as linear force applied to a point on the lever handle). For joystick controls, elastic resistance which increases with displacement may be used to improve "stick feel".

5.2.1.8.5 Detents. When levers are used as "selector" controllers, mechanical detents should be provided (in addition to panel labels or markings) to provide tactile feedback indicating that the lever is positively positioned at designated settings. Detents and panel markings should coincide precisely.

MIL-HDBK-759B

5.2.1.8.6 Non-slip handles. Surfaces of lever handles should provide sufficient friction (by means of the specific material used, and/or addition of serrations or knurling) to reduce the probability of the operator's hand or fingers slipping while operating the lever.

5.2.1.8.7 Dimensions, displacement, and separation. Lever dimensions, displacement and separation should conform to criteria in Table 7.

5.2.1.8.8 Marking and labeling. Where appropriate, lever handles should be marked and/or labeled for ease of positioning and identification.

5.2.1.8.9 Coded handles. Color and/or shape coding may be used when it is important for the operator to quickly identify and/or differentiate among critical controls or several controls that may be grouped in proximity to each other. Special control coding criteria already established should be followed. When shape-codes are used, they should be designed so that they do not interfere with the basic criteria for ease of manipulation, and should be free of sharp corners that could result in operator injury in the event of violent contact by the operator.

5.2.1.9 Foot-operated controls.

5.2.1.9.1 General. Foot-operated controls should be considered when:

- a. control system forces require that the human interface force application will be greater than the hand or arm strength of the 5th percentile operator, and/or so near this limit to cause serious fatigue for the operator;
- b. the operator's hands are generally occupied by other manual control tasks at the same moment that an additional control action is required;
- c. specific foot-operated controls have been so well established that the average operator expects such operating functions to be performed using foot controls (aircraft rudder/brake pedals, automotive clutch, brake and accelerator pedals); and
- d. when a safety "shut-down" control is required during an operation in which the operator's hands cannot be freed to reach a safety switch.

5.2.1 .9.2 Avoidance. Foot-operated controls should not be used under the following conditions:

- a. for a standing operator who may be working on a moving platform (where balancing on the non-operating foot may become difficult as the operating foot is moved from a support to actuating position),
- b. to affect very precise control operations, and
- c. to select among a great many separate foot controls.

TABLE 7. Levers

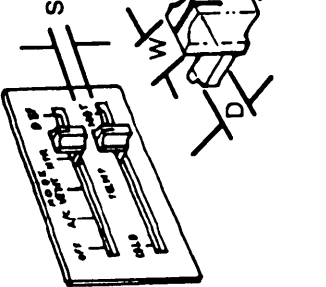
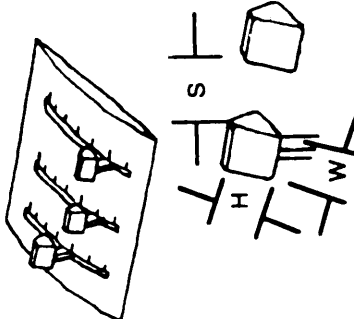
CONFIGURATION EXAMPLE	APPLICATION CRITERIA	DESIGN CRITERIA		
		DIMENSIONS	DISPLACEMENT	SEPARATION
	<p>SLIDE-LEVERS MAY BE USED FOR LOW-FORCE, CONTINUOUS-ADJUSTMENT OR GROSS-MODE SELECTION (DO NOT USE FOR PRECISE-SETTING).</p> <p>HANDLES SHOULD BE "TAB-SHAPED", WITH LONG DIMENSION PERPENDICULAR TO MOTION AXIS (TO SERVE AS A POINTER).</p> <p>MOVEMENT AXIS MAY BE UP-DOWN, LATERAL OR FORE-AFT. FUNCTIONAL INCREASE SHOULD BE:</p> <ul style="list-style-type: none"> • UP • RIGHT • FORWARD 	<p>D - MIN. = 13 mm OR 19 mm WITH GLOVES</p> <p>W - MIN. = 6.5 mm</p> <p>H - MIN. = 16 mm</p>	<p>S - MIN. 19 mm OR 25 mm WITH GLOVES</p>	<p>SAME AS ABOVE</p>
	<p>BANKED, SLIDE-LEVER ASSEMBLIES MAY BE USED FOR ELECTRICALLY- AND/OR MECHANICALLY-CONNECTED SELECTOR OR ADJUSTMENT FUNCTIONS TO PROVIDE RAPID VISUAL CHECK OF RELATED SETTINGS.</p> <p>NOTE: RESISTANCE FOR ABOVE CONTROL TYPES SHOULD BE:</p> <p>MIN - 2.8N MAX - 110N</p>	<p>SAME AS ABOVE</p>	<p>SAME AS ABOVE</p>	<p>SAME AS ABOVE</p>

MIL-HDBK-759B

TABLE 7. Levers - continue

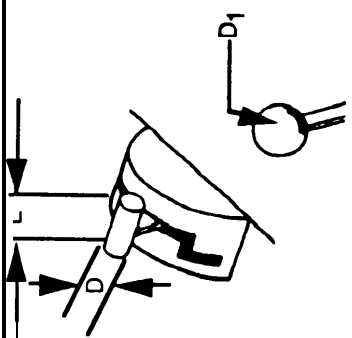
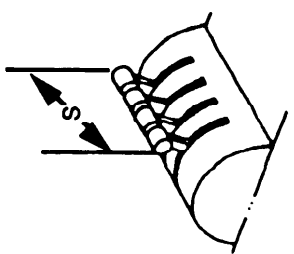
CONFIGURATION EXAMPLE	APPLICATION CRITERIA	DESIGN CRITERIA		
		DIMENSIONS	DISPLACEMENT	SEPARATION
	<p>THROTTLE LEVERS: HANDGRIP MAY BE EITHER CYLINDRICAL OR SPHERICAL</p>	<p>D-MIN 9 mm MAX 28 mm D 38±6 mm</p> <p>L-MIN=65 mm</p>	--	<p>50 mm MIN FINGER CLEARANCE ALL SIDES</p>
	<p>MULTI-ENGINE THROTTLE ASSEMBLY:</p> <p>NOTE: WHEN THRUST REVERSE IS INCORPORATED, THE DESIGN SHOULD INCLUDE A SEPARATE MANIPULATIVE MOTION ('LIFT' + AFT LEVER MOVEMENT).</p>			<p>S-TYPICAL=100 mm NOT TO EXCEED 125mm</p>

MIL-HDBK-759B

TABLE 7. Levers - continued

CONFIGURATION EXAMPLE	APPLICATION CRITERIA	DESIGN CRITERIA		
		DIMENSIONS	DISPLACEMENT	SEPARATION
	<p>GEAR-SHIFT LEVER:</p> <p>MANUAL TRANSMISSION:</p> <p>LOCATE FOR RIGHT-HAND OPERATION</p> <p>RESISTANCE: APPROXIMATELY 9-13 N</p>	D - KNOB DIAMETER=32 mm	<p>d_1 AND d_2 MIN. BETWEEN DISCRETE POSITIONS = 125 mm MAX TOTAL = 200 mm</p>	N/A
	<p>AUTOMATIC TRANSMISSION: (B₁ PREFERRED; B₂ ACCEPTABLE). DETENTED POSITIONS REQUIRED*</p> <p>A. OTHER FUNCTIONS:</p> <ol style="list-style-type: none"> 1. TURN SIGNAL - ROTATE ABOUT COLUMN; CW = R-TURN, CCW = LEFT TURN. 2. HEADLIGHT-DIMMING LEVER MOVES TOWARD BOTTOM OF COLUMN FOR "DIM". <p>B. LETTERS SHOULD ILLUMINATE TO INDICATE POSITION OF LEVER.</p> <p>RESISTANCE: APPROXIMATELY 4.5 - 45 N</p> <p>*IT SHOULD BE IMPOSSIBLE TO LEAVE GEAR LEVER BETWEEN POSITIONS. SEPARATE MOTION REQUIRED TO POSITION LEVER IN REVERSE (LIFT OR PRESS THUMB BUTTON).</p>	<p>D - HANDLE DIAMETER = 19-32 mm IF CYLINDRICAL, 25-32 mm IF SPHERICAL</p>	<p>FINGER CLEARANCE BETWEEN LEVERS AND WHEEL RIM - MIN. 50 mm</p> <p>GEAR SHIFT - MIN. BETWEEN POSITIONS = 25 mm FOR B₁; 38 mm FOR B₂</p> <p>RESEARCH DATA NOT AVAILABLE BUT RECOMMEND 25-50 mm BETWEEN DETENTS</p>	

TABLE 7. Levers - continued

CONFIGURATION EXAMPLE	APPLICATION CRITERIA	DESIGN CRITERIA		
		DIMENSIONS	DISPLACEMENT	SEPARATION
	<p>HAND BRAKE, WITH THUMB-BUTTON RELEASE. (SEE FOOT PEDAL ALTERNATIVE).</p> <p>L₁ - LOOP HANDLE ACCEPTABLE</p>	D - DIAMETER = 25-32 mm	NOMINAL = 100-125 mm	MIN = 65 mm ALL SIDES OF HANDLE
		L - LENGTH = MIN 100 mm	C - MIN CLEARANCE = 50 mm	MAX FOR SEATED OP = 355 mm
	<p>HIGH-FORCE LEVERS: CENTER OF HANDLE SHOULD BE APPROXIMATELY 230-255 mm LATERALLY FROM OPERATOR CENTERLINE, AT ELBOW LEVEL. PROVIDE CLIP-TYPE RELEASE WHERE APPLICABLE.</p> <p>ROUND OR OVAL-SHAPED HANDLE SHOULD BE USED.</p> <p>RESISTANCE APPROXIMATELY MAX - 187 N</p>	MAX A X B = 38 X 25 mm;	L - LENGTH = MIN 100 mm	
		D = 38-45 mm WITH CLIP LEVER MAX FORE-AFT SPAN SHOULD NOT EXCEED 75 mm		

MIL-HDBK-759B

TABLE 7. Levers - continued

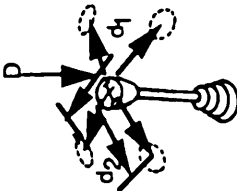
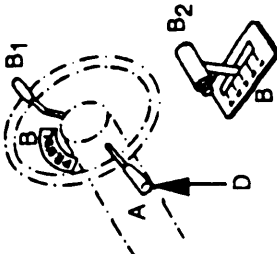
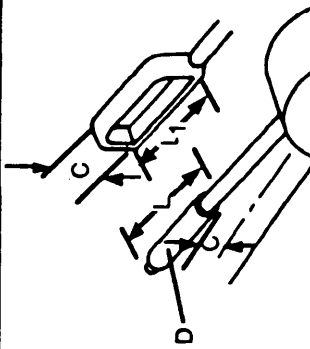
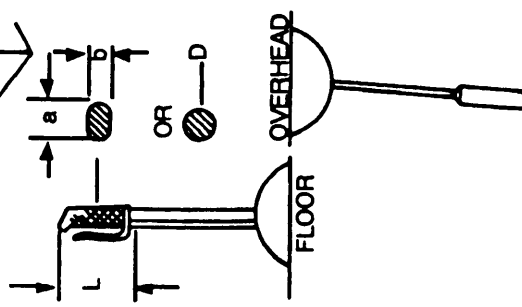
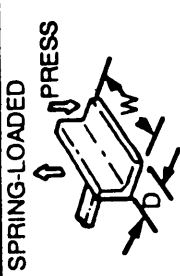
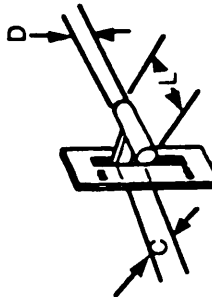
	APPLICATION CRITERIA	DESIGN CRITERIA			SEPARATION
		DIMENSIONS	DISPLACEMENT		
 <p>SPRING-LOADED</p>	<p>TWO-POSITION, SPRING-RETURN TO "OFF" TAB-LEVER. USE ONLY IN UP-DOWN ORIENTATION. RESISTANCE: APPROXIMATELY 4.5 - 27 N</p>	<p>D - MIN = 19 mm</p> <p>W - MIN = 25 mm</p>	<p>DISPLACEMENT = 25 - 75 mm</p>	<p>-</p>	<p>-</p>
	<p>HEAVY-DUTY LEVER DEVICE HANDLES SHOULD PERMIT USE OF AT LEAST THREE FINGERS. USE ONLY IN UP-DOWN ORIENTATION.</p> <p>RESISTANCE: APPROXIMATELY 4.5 - 45 N</p>	<p>D - MIN = 16 mm</p> <p>L - MIN = 65 mm</p>	<p>C - MIN CLEARANCE = 32 mm, 38 mm WITH GLOVES</p>	<p>MIN = 50 mm</p>	<p>MIN. SEPARATION BETWEEN ENDS OF HANDLES = 19 mm OR 25 mm WITH GLOVES; MIN. CLEARANCE OF 50 mm BEHIND HANDLE</p>

MIL-HDBK-759B

5.2.1.9.2.1 Operation. Foot controls should be located and designed so they can be operated in as natural a pattern as practicable. Specifically, the designer should avoid configurations that require:

- a. frequent, maximum reaching,
- b. holding the leg or foot in an awkward position for extended periods of time,
- c. sitting in a twisted position to operate a control that is used frequently and/or for an extended period of time (pedals should be laid out symmetrically with reference to the operator's principal operating orientation),
- d. frequent or extended application of maximum force,
- e. visual searching for a particular foot control in order to select the right one, and
- f. placement of a foot control where it might be stepped on and inadvertently actuated, and/or where typical shifting from one foot control to another creates a high probability that the foot or clothing might be entrapped by an intervening control as the operator shifts the foot from one control to another.

5.2.1.9.3 Foot switches.

5.2.1.9.3.1 Application. Foot-operated switches should be used only in those cases where the operator is likely to have both hands occupied at the time the push button is activated, or where load-sharing among limbs is desirable. Because foot-operated switches are susceptible to accidental activation, their uses should be limited to non-critical or infrequent operations such as press-to-talk communication or vehicle headlight dimming.

5.2.1.9.3.2 Operation. Foot switches should be located so that they can be operated by the toe or ball of the foot rather than by the heel. They should not be located so near an obstruction that the operator cannot position the sole of the shoe squarely (centered) on the switch button. A pedal may be used atop the button to aid in location and operation of the switch. When switches are used in an environment in which the switch may become wet and slippery, the switchcap surface should possess a frictional surface to minimize the possibility of the foot slipping off the switch.

5.2.1.9.3.3 Switch location. In addition to the above, foot-operated switches should be located so the operator has some normal heel resting position on the floor or a floor board. Avoid placing a foot switch beneath or behind other pedals wherein it might be possible for the operator's foot to become momentarily entangled or trapped during the transfer between the switch and a pedal.

MIL-HDBK-759B

5.2.1.9.3.4 Dimensions, displacement, and separation. Dimensions and displacement of foot-operated switches should conform to the criteria in Figure 13. One switch per foot is preferred; however, when more than one switch must be provided for the same foot to operate, such switches should be at least 75 mm apart (horizontal) and 200 mm (vertical).

5.2.1.9.3.5 Resistance and feedback. A positive indication of control activation should be provided (snap feel, audible click, associated visual or auditory display). Resistance should be between 45N and 90N.

5.2.1.9.4 Pedals.

5.2.1.9.4.1 Application. Pedal controls should be used only when the operator is likely to have both hands occupied at the time the foot operation is required, when the control system force is too high for manual force capability of the operator, or where standardized use of pedals has created a stereotype expectancy on the part of the operator (vehicle pedal control configurations such as clutch, brake, accelerator, rudder).

5.2.1.9.4.2 Location. Pedal controls should be within anthropometric and force capability of the operator (see Tables 28, 33, 38 and 39). They should be located so that the operator can reach them easily, without extreme stretching or torso-twisting to reach the the maximally displaced pedal. Pedals that may be held or that have to be adjusted fairly precisely (accelerator) should be located so that the operator can rest and steady the foot. The pedal should be an appropriate critical distance above the floor so the operator's heel can rest on the floor while articulating the ankle/foot. When this cannot be done (and the pedal angle is more than 20° from the horizontal floor), a heel rest should be provided.

5.2.1.9.4.3 Control return. Except for controls which generate a continuous output (rudder controls), foot controls should have a spring-return system with sufficient force to return the pedal to the original null position without requiring assistance from the operator (brake pedal). Where the operator may normally rest the foot on the pedal between operations, such as with an accelerator pedal, sufficient spring tension should be provided to prevent the weight of the foot from inadvertently activating the control.

5.2.1.9.4.4 Play. Pedal control systems should be designed to minimize excess "play" (movement that does not activate the control system).

MIL-HDBK-759B

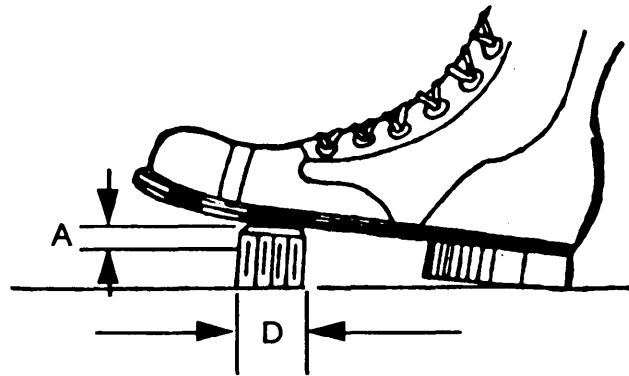

	Diameter D	Resistance		Displacement A			
		Foot Will Not Rest On Control	Foot Will Rest on Control	Normal Operation	Heavy Boot Operation	Ankle Flexion Only	Total Leg Movement
Minimum	13 mm	18N	45 N	13 mm	25 mm	25 mm	25 mm
Maximum	--	90 N	90 N	65 mm	65 mm	65 mm	100 mm

FIGURE 13. Foot-operated switches

5.2.1.9.4.5 Adjustment. Sufficient control and/or seat adjustment capabilities should be provided to accommodate the leg reach capabilities of the total range of expected operators (5th percentile female-95th percentile male). Consideration should also be given to combined vertical/horizontal adjustment effect on reach. For seated operator configurations where external vision is critical and corresponding control panel constraints may be present, the pedal/seat/vision interactions should be considered to provide the best-fit among eye reference, seat and pedal adjustment position and adjustment range.

5.2.1.9.4.6 Pedal travel path. The travel path (typically an arc) should be considered in the design of pedal systems and should be compatible with the natural articulation path of the operator's thighs, knees, and ankles.

5.2.1.9.4.7 High-force application aids. When the force required to fully actuate a pedal is extremely high, appropriate aids should be provided to assist the operator in applying maximum force to the pedal. The following should be considered:

- a. seat backrest,
- b. optimized seat height-to-pedal and normal reach distance for maximum force (seat reference point/pedal at same vertical height; reach distance so the

MIL-HDBK-759B

upper thigh and lower leg create an angle just short of horizontal, see Tables 28, 33, 38 and 39), and

c. double-width pedal so that both feet could be used.

5.2.1.9.4.8 Non-skid pedal surface. Pedals used for high force applications should be provided with a non-skid surface. Similar surfaces are desirable for all pedals.

5.2.1.9.4.9 Dimensions, resistance, displacement, and separation. Dimensions, resistance, displacement, and separation of pedals should conform to the criteria in Table 8.

5.2.1.9.5 Automotive-related foot controls.

5.2.1.9.5.1 Arrangement. Assemblies of foot-operated controls should conform to industry practice with respect to arrangement.

- a. Manual transmission: The clutch should be positioned for left-foot operation, service brake and accelerator for right-foot operation. Headlight dimmer function may be provided as a left /right hand- or foot-operated floor switch or column-mounted stalk (lever).
- b. Automatic transmission: The above arrangement should be followed except that the service brake should be accessible for either right- or left-foot operation (in which case the brake pedal should be laterally elongated sufficiently to make it convenient for operation by either foot).

5.2.1.9.5.2 Pedal, geometric relationships. Clutch, service brake, and accelerator pedals should be arranged so that the primary contact point of each pedal (height and distance from the floor, heel-reference point) is approximately the same, to make it convenient for the operator to shift his foot from the accelerator to the service brake pedal without having to lift the foot an excessive amount. The pedal contact point should be based on a point on the accelerator pedal that matches an "all-of-the-foot" position when the operator's heel rests normally on the floor, and the accelerator pedal is in the "un-depressed" position. Lateral pedal positions should be arranged and spaced so that the total array is approximately centered on the operator's centerline (so the operator is not required to sit in a skewed position in order to operate certain pedals). For maximum, long-duration comfort, the accelerator pedal should be not more than about 300 mm right of the operator's centerline.

5.2.1.9.5.3 Lateral pedal array limits. Lateral spacing of individual pedals should conform to criteria in Table 8. However, the overall array should not exceed 760 mm as measured between the outermost pedal centerlines.

TABLE 8. Foot-operated controls

		DESIGN CRITERIA		
	APPLICATION CRITERIA	DIMENSIONS	DISPLACEMENT	SEPARATION
	<p>BRAKE PEDAL APPLICATIONS: CLUTCH-BRAKE-CONVEX TREAD SURFACE</p> <p>FORCE REQUIREMENTS: CLUTCH = 450 N (MAX). BRAKE = 70 N (MIN), 450 N (MAX)</p> <p>ALTERNATIVE PEDAL SHAPE & SPACING. CONVEX, TREAD SURFACE</p>	<p>W x D - MIN = 75 X 50 mm</p> <p>W x L - MIN = 50 X 75 mm</p>		<p>S - MIN TO PREVENT FOOT SLIPPING BETWEEN PEDALS = 50 mm</p> <p>S - MIN SEPARATION TO ALLOW FOOT TO PASS BETWEEN PEDALS = 125 mm; 180 mm FOR HEAVY BOOTS</p>
	<p>ROUND PEDAL SHAPE ACCEPTABLE. FLAT, TREAD SURFACE</p>	<p>D - MIN = 57 mm</p>	<p>S - COMFORT SEPARATION = 305 +/- 50 mm MAX = 405 mm</p> <p>MIN = 200 mm</p>	<p>d - MAX REST TO ACTIVATE = 180 mm MIN = 25 mm PREFERRED 65-100 mm</p>
	<p>ACCELERATOR PEDAL APPLICATIONS: A. FLOOR-HINGED, FULL PEDAL B. SUSPENDED PEDAL (PEDAL SHOULD BE FREE-SWIVEL)</p>	<p>W = 50 mm MINIMUM L₁ = 255 +/- 50 mm L₂ = 90 mm MINIMUM</p>		
	<p>ACTION DISPLACEMENT ENVELOPE. NOMINAL CRUISE ANGLE* SHOULD CAUSE LOWER LEG/FOOT, INCLUDED ANGLE TO BE BETWEEN 90°-105°.</p> <p>FORCE REQUIREMENTS: MAX = 90 N MIN = 4.5 N</p> <p>* NOMINAL CRUISE = LEVEL GRADE. AVERAGE SPEED FOR APPLICATION</p>			<p>a - MAX DISPLACEMENT = 30° (20° WITH HEAVY BOOTS)</p>

TABLE 8. Foot-operated controls - continued

		DESIGN CRITERIA		
		DIMENSIONS	DISPLACEMENT	SEPARATION
<p>APPLICATION CRITERIA</p> <p>AIRCRAFT RUDDER/BRAKE ASSEMBLY. SHOULD HAVE MIN FOR AFT ADJUSTMENT OF 230 mm. TOE PRESSURE OPERATES BRAKE, FORE-AFT MOVEMENT OF PEDAL FULCRUM OPERATES RUDDER (RIGHT PEDAL RWD = RIGHT TURN).</p> <p>FORCE REQUIREMENTS: SEE MIL-F-8785.</p> <p>FOOT SWITCHES. NORMALLY USE ONLY ONE PER FOOT (MAX TWO) FORCE REQUIREMENTS: MAX 4.5 N (SEE MIL-B-8584 FOR SPECIFIC DIMENSIONS)</p> <p>FOOT SWITCHES, STAND OPTIONS: NORMAL FREQUENT ACTIVATION, SPEED NOT CRITICAL</p> <p>FORCE REQUIREMENTS: PREFERRED MAX 90 N EMERGENCY OPERATION, SPEED IMPORTANT</p>		<p>W - MIN = 150 mm</p> <p>L₁ - MIN = 255 mm</p> <p>L₂ - MIN = 125 mm</p>	<p>MIN = 13 mm</p> <p>MAX = 65 mm</p> <p>FOR BOOTS, INCREASE MIN TO 25 mm</p>	<p>S - MIN = 380 mm</p> <p>MAX = 530 mm</p>
		<p>D - MIN DIAMETER = 25 mm</p> <p>D - MIN BUTTON DIAMETER = 25 mm</p> <p>LARGER PREFERRED</p> <p>E - EXTENSION MIN = 100 mm</p>	<p>C - CLEARANCE TO OBSTRUCTON MIN = 75 mm</p> <p>C - CLEARANCE BENEATH UNDEPRESSED BAR FOR TOE, MIN = 65 mm OR 75 mm WITH BOOTS</p>	<p>S - MIN = 75 mm</p>

MIL-HDBK-759B

5.2.1.10 Push button switches (hand-operated).

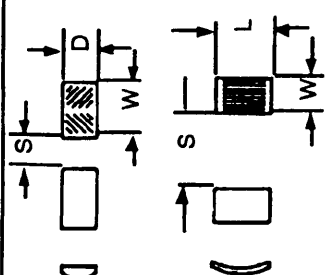
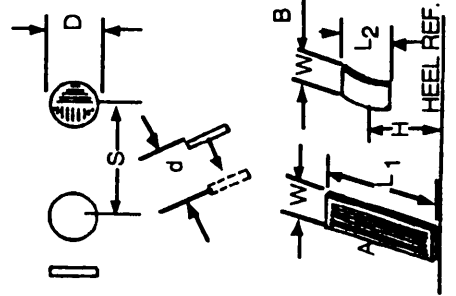
5.2.1.10.1 Application. Push button controls should be used primarily for simple switching between two conditions, selection of alternate on-off functions from an array of related conditions or subsystem functions, release of a locking system such as on a parking brake or entry of a discrete control order. Push buttons should not be used indiscriminately merely to make all panel controls “look alike”, or where another type of switch could be used to save panel space (toggle switch). Push button-type controls may be used for any of the following kinds of operations singly or in combination (see Table 9).

5.2.1.10.1.1 Momentary contact. This should be used for single “push-HOLD/release-OFF” functions. The push button should be one of the following types: (1) non-illuminated, (2) continuously on switchcap light or legend, or (3) momentary on switchcap light.

5.2.1.10.1.2 Alternate action. Alternate action for a single function may be implemented either in a two-button format or as a single button. With the single-button type, a first press sets the switch to the ON state and a second press sets it to OFF. Feedback to indicate the ON state should be provided either by switchcap lamp or legend or by a closely associated lamp or legend. With the two-button type, the buttons are mechanically interlocked so that one button is always depressed and the other button is in the up position. Although the depressed button provides feedback on switch state, additional feedback by means of switchcap lamp or closely associated lamp or legend should normally be provided.

5.2.1.10.1.3 Stepping action. Successive presses of the switch cycle it through three or more states. Switch state feedback may be provided by selective illumination of integral or associated legends.

5.2.1.10.1.4 Combination. Sets of related switching functions of the above types may be combined as an assembly. These may be independent, interlocked or a combination of both, may be momentary or latching or a combination of both; and may be non-illuminated, or have switchcap lights or legends. Feedback as to active switch states should always be provided. Interlocking and latching functions may be either mechanical or electrical (see 5.2.1.11).

5.2.1.10.2 Dimensions. displacement. and separation. Dimensions, displacement, and separation of push button controls (except those in keyboards) should conform to the criteria in Table 10. Actuating force for push buttons should be within the following limits.

- a. buttons used in keypads and keysets, 0.25 N to 1.5 N,
- b. other single-finger actuated buttons, 0.25 N to 11.1 N,
- c. large (2.5 mm square or larger) panel-mounted buttons for thumb actuation, 1.1 N to 16.7 N,

MIL-HDBK-759B

TABLE 9. Representative push button switch applications

Function	Switch Action	Switch Configuration	Switch State Feedback Options					Other Display Reflecting Switch Action
			Depressed Switchcap	Integral Lamp(s)	Integral Legend(s)	Adjacent Lamp(s)	Adjacent Legend(s)	
Send short discrete signal to initiate or terminate some other function.	Momentary contact	Single button	Momentary only	Momentary only	Momentary only	Momentary only	Momentary only	Sufficient
Send short signal of controllable duration.	Momentary contact	Single button	Momentary only	Momentary only	Momentary only	Momentary only	Momentary only	Sufficient
Choose between two mutually exclusive states	Alternate action, latching	Two-button interlocked or Single-button	If mechanically latched	C	Sufficient	C	Sufficient	C
Step through three or more switch states.	Stepping, latching	Single button with legend matrix	If mechanically latched	C	Sufficient	C	Sufficient	C
Independently choose one out of three or more mutually exclusive states.	Latching and interlocked	Array of buttons	(No)	(No)	Sufficient (if multiple legend)	C	Sufficient	C
Independently choose two or more out of a set of control functions each having two states.	Alternate action, latching	Array of buttons	If mechanically latched	C	Sufficient	C	Sufficient	C

NOTES:

1. The feedback referred to pertains only to knowledge of switch state, not system state (which may impose additional feedback requirements).
2. A feedback option designated "sufficient" means that, properly instrumented it can provide all the information the operator needs concerning switch state; other methods showing annotation or C (contributing) need to be used in combination to provide adequate feedback.

TABLE 10. Push button switches

DESIGN CRITERIA		DIMENSIONS		DISPLACEMENT	SEPARATION
<p>APPLICATION CRITERIA</p> <p>PANEL-MOUNTED PUSH BUTTONS: SINGLE-FINGER, ONE BUTTON AT A TIME. NON-LEGND OR BUTTONS THAT REQUIRE ONLY A SINGLE NUMBER ON THE FRONT SURFACE MAY BE ROUND, SQUARE OR RECTANGULAR.</p> <p>A CONCAVE SURFACE MAY BE USED TO AID FINGER-CENTERING (NON-GLOVE OPERATION ONLY).</p> <p>RECESSED BUTTON TO MINIMIZE INADVERTENT OPERATION. TAPERED "WELL" GUIDES FINGER.</p> <p>PREVENT INADVERTENT OPERATION OF CRITICAL SWITCH, EITHER WITH GUARD RING, OR PANEL WELL</p> <p>*FOR MINIATURIZED APPLICATIONS DIAMETER AS SMALL AS 3.2mm MAY BE USED SUBJECT TO APPROVAL BY THE ACQUIRING ACTIVITY.</p>		<p>D - MIN DIAM. OR DIMENSION (D1) - 10mm*</p>	<p>---</p>	<p>---</p>	<p>S - MIN = 19mm (OR) S1 - MIN = 13mm S = 25mm WITH GLOVES</p>
		<p>MAX = 19mm D - MIN = 13mm</p>	<p>---</p>	<p>---</p>	<p>---</p>
<p>---</p>	<p>---</p>	<p>D - MIN WELL OPENING = 19mm; 32mm WITH GLOVES</p>	<p>---</p>	<p>---</p>	<p>---</p>
<p>---</p>	<p>---</p>	<p>D - SAME AS ABOVE</p>	<p>---</p>	<p>---</p>	<p>---</p>

TABLE 10. Push button switches - continued

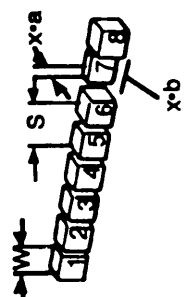
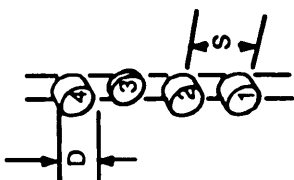
APPLICATION CRITERIA	DESIGN CRITERIA		
	DIMENSIONS	DISPLACEMENT	SEPARATION
 <p>GANGED PUSH-BUTTON ASSEMBLY: SQUARE, RECTANGULAR, OR ROUND SHAPES ARE ACCEPTABLE. DEPRESSION OF ANY BUTTON SHOULD CAUSE ANY PREVIOUSLY-DEPRESSED BUTTON TO RETURN TO DEACTIVATED POSITION.</p> <p>NUMBERED BUTTONS SHOULD PROGRESS AS ILLUSTRATED.</p> 	<p>W or D MIN = 10mm (13mm FOR GLOVES)</p> <p>---</p>	<p>---</p> <p>x.a - MIN EXPOSURE WHEN DEPRESSED = 3.2mm x.b - MIN DEPRESSION TO ACTIVATE = 3.2mm (PREFERRED = 5mm) NOTE: MAX DISPLACEMENT SHOULD NOT EXCEED 13mm</p>	<p>S - CTR-CTR SPACING MIN = 19mm (25mm FOR GLOVES)</p>

MIL-HDBK-759B

TABLE 10. Push button switches - continued

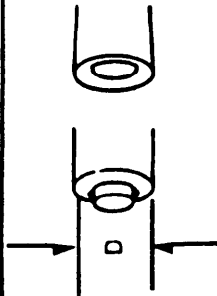
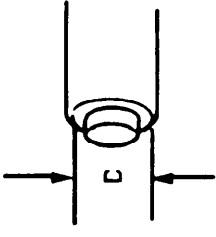
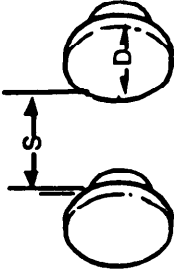
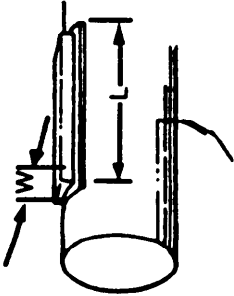
	APPLICATION CRITERIA	DESIGN CRITERIA			
		DIMENSIONS	DISPLACEMENT	SEPARATION	
	HANDLE, END-MOUNTED, PUSH BUTTON SWITCH; INDEX FINGER-OPERATED. RECESS TO PRECLUDE INADVERTENT OPERATION.	D - MINIMUM = 10mm	SAME AS ABOVE	N/A	
	THUMB-OPERATED	D - MINIMUM = 13mm	SAME AS ABOVE	N/A	
	ALTERNATE FINGER OR HEEL OF THE HAND OPERATION. CONVEX SURFACE DESIRABLE.	D - MINIMUM = 25mm	SAME AS ABOVE	S - MIN FOR PALM OPN = 75mm	
	GRIP HANDLE SWITCH ALTERNATE MULTI-FINGER OR PALM OPERATION	W - MINIMUM = 6.5mm L - PREFERRED MIN = 25mm	SAME AS ABOVE	N/A	

MIL-HDBK-759B

- d. still larger (greater than 38 mm wide) panel-mounted buttons for multi-finger heel of hand actuation, 1.7 N to 22.2 N.

5.2.1.10.3 Indication of switch activation. Positive feedback should be provided to indicate that the push button switch has been activated or deactivated. The following methods should be considered.

- a. Switch displacement should be visible.
- b. Tactile/auditory indication should be provided (gradual resistance build-up to sudden resistance-release--snaps into place), accompanied by an audible "click".
- c. An accompanying visual indication is provided (switchcap is illuminated).

5.2.1.10.4 Push button identification/legends. Although push buttons may be identifiable by means of panel labels and/or symbols, labels placed on the push button face (where size and other use factors are compatible) are preferred. Criteria for labels, symbols and legends should be followed. Legends normally should be legible with or without internal illumination, but legends may be invisible during any distinct modes in which the button is never used. A lamp test capability and/or dual lamp reliability should be provided, except for switches using light-emitting diodes (LEDs) in place of incandescent lamps. No more than three lines of lettering should normally be used on a legend plate. Lamps within incandescent legend switches should be replaceable from the front of the panel, by hand, and the legend or cover should be keyed to prevent possibility of interchanging legend covers.

5.2.1.10.5 Push button cap shape. Cap surfaces should, in general, be flat, but with rounded edges. However, for proper finger-centering, which should be ensured, the cap surface may be concave. General cap shapes may be round, square, or rectangular as long as they provide adequate finger, thumb or hand contact area, and are compatible with identification or legend criteria.

5.2.1.10.6 Inadvertent switch activation. Primary methods for minimizing inadvertent switch activation should conform to criteria in Table 10. If, however, it is imperative to prevent accidental activation of a specific switch, a channel or cover guard should be provided, and/or other suitable technique, that requires the operator to perform a preceding action prior to final switch activation, should be used.

5.2.1.11 Keyboards, keypads, keysets, and menu selectors.

5.2.1.11.1 Applications.

- a. Alphanumeric keyboards with standard typewriter key configurations should be used for applications where a general-purpose entry criteria cannot be satisfied by numeric entries alone, by smaller keysets with either dedicated or programmable keys, or by menu selection techniques.

MIL-HDBK-759B

- b. Keypads (decimal entry keysets) should be used for applications requiring frequent entry of decimal digits, whether data or numeric codes.
- c. Keysets with each key dedicated to a specific switching function should be used whenever the number of switching functions is manageable and need not change with time or operational condition.
- d. Multi-function (programmable) keysets offering means of changing the switching function of individual keys should be utilized whenever switching criteria vary substantially for different phases or modes of operation and the total number of functions to be switched cannot be conveniently handled by dedicated keys.
- e. Menu selection techniques which provide for display and selection of switchable states on a "CRT may be used as an alternate to the multi-function keyset.

5.2.1.11.2 Keyboards (alphanumeric keysets in typewriter configuration).

5.2.1.11.2.1 Configuration. Keyboard configurations should be of the QWERTY arrangement and should conform to MIL-STD-I1280. Key action should be of the momentary contact type.

5.2.1.11.2.2 Dimensions, resistance, displacement, and separation. The dimensions, resistance, displacement and separation between adjacent edges of the push buttons which form keyboards should conform to the criteria in Table 11. For a given keyboard these criteria should be uniform for all individual keys. For those applications where operation while wearing gloves is required, the minimum key size should be 19 mm. Other parameters are unchanged from those of bare-handed operation (see Table 11).

5.2.1.11.2.3 Mounting. The keyboard should be mounted so that it is directly in front of the operator when it is in use. The first row of keys should be between 230 mm and 300 mm above the seat level and the tiers of keys should slope upward toward the back at an angle between 10° and 30° from the horizontal with 17° preferred (see Table 12).

5.2.1.11.2.4 Feedback. Feedback should be provided to inform the operator whether or not the pressed key was, in fact, actuated; the intended key selection was the one which was made; and an entire message or message segment is ready for the next operation (filing, transmission, and computer storage).

MIL-HDBK-759B

TABLE 11. Keyboards

	Dimensions		Resistance		
	Key Diameter D				
	Bare-headed	Arctic mittens*	Numeric	Alpha-numeric	Dual Function
Minimum	10mm	19mm	1 N	250 mN	250 mN
Maximum	19mm		4N	1.5N	1.5N
Preferred	13mm	19mm			
	Displacement			Separation	
	Numeric	Alpha-numeric	Dual Function	(between adjacent key tops)	
Minimum	0,8 mm	1.3 mm	0.8 mm	6.4 mm	
Maximum	4.8 mm	6.3 mm	4.8 mm		
Preferred				6.4 mm	

*Trigger finger type.

5.2.1.11.2.5 Function control. Convenient means of switching keyboard function and indicating keyboard state should be provided to enable composing and posting message text prior to its release, editing posted data or text material, and directly entering data or instructions to a computer.

5.2.1.11.3 Keyboards (decimal entry keysets).

5.2.1.11.3.1 Configuration. For telephone use, any communications addressing function, or entry of numeric data, the push button telephone configuration should be used. This is a 3 x 3 + 1 configuration, with the top row consisting, left to right, of the numerals 1, 2, and 3; the second row, 4, 5, and 6; the third row, 7, 8, and 9; and the zero is centered under the bottom row (see Table 12.)

5.2.1.11.3.2 Dimensions, displacement, and separation. Telephone-type keypads may be of the commercially-available type unless otherwise specified. Minimum dimensions, displacement, and separation of other keypads should conform to those for commercial push button phones, except in the conditions that follow.

- a. Displacement may be less or zero if touch-activated switches with appropriate feedback are used.
- b. Key size, separation, and displacement should be as indicated in Table 11 if heavy gloves or mittens are to be worn by users.

MIL-HDBK-759B

TABLE 12. Nominal keyboard characteristics

Telephone	
	<p>K - Key Size = 9.5 mm</p> <p>S - Separation = 6 mm</p> <p>H - Height = 6 mm</p> <p>X - Depressed Extension = 1.6 mm</p> <p>C/C - Center/Center Spacing = 16.7 mm</p> <p>NOTE: For other dimensions refer to Table 10 for single finger push buttons.</p>
Typewriter	
	<p>K - Key Size = 12.7 mm</p> <p>C/C - Center/Center Spacing = 19 mm</p> <p>D - Displacement = 4.7 mm for electric; 1.6 mm for typical manual machine</p> <p>A - Varies widely; preferred slope is between 16-17°</p>

5.2.1.11.3.3 Mounting. Keypads may be mounted wherever they are conveniently available for use. Keypads requiring frequent use should be mounted in a preferred location for controls such as a desk top and should be sloped as is required for keyboards.

5.2.1.11.3.4 Actuating force. The actuating force required for keypads should fall in the range of 0.25 N to 3.9 N. (This actuating force range does not apply to touch-activated keypads.) The larger actuating forces should be used where the user wears gloves or mittens, or is subjected to substantial vibration or acceleration.

MIL-HDBK-759B

5.2.1.11.3.5 Feedback (see 5.2.1.11.2.4).

5.2.1.11.3.6 Function control. Switches for control functions should be provided to allow clearing either the last posted digit only or all posted digits.

5.2.1.11.4 Dedicated keysets.

5.2.1.11.4.1 Configuration. A dedicated keyset consists in essence of two or more push button sets which are grouped together because of some commonality of purpose and which utilize some common control and/or display functions. As best fits the purpose, key action may be momentary contact or latching, and key tops may (1) be opaque, (2) contain an indicating lamp, (3) provide a continuously illuminated label, (4) provide an illuminated label when activated, or (5) provide both (3) and (4). The functions and physical configuration of the push buttons in the keyset should be appropriate to the switching functions it should handle and to the operator's task.

5.2.1.11.4.2 Dimensions, displacement, and separation. Dedicated keysets which do not utilize switchcap labels should conform to the dimensional criteria for keyboards in Table 11. Those which do use switchcap labels should conform to the criteria for legend switches (see 5.2. 1.7). (The displacement criteria do not apply to touch-actuated switches.)

5.2.1.11.4.3 Mounting. Dedicated keysets may be mounted wherever they are conveniently available for use.

5.2.1 .11.4.4 Actuating force. The actuating force required for dedicated keysets should fall in the range of 0.25 N to 11.3 N. The larger actuating forces should be used only with large-size illuminated switchcaps which are 25 mm wide or larger as may be needed to accommodate switchcap labeling. The preferred actuating force for push buttons which can be mounted on 20 mm centers is about 2.8 N.

5.2.1 .11.4.5 Feedback. Feedback should be provided to inform the operator whether or not the pressed key was, in fact, actuated; the intended key selection was the one which was made; the system is in the process of responding to the actuated key; and the system has completed its response to the actuated key.

5.2.1 .11.4.6 Function control. Switches for control functions governing operation of the keyset should be provided as needed for the particular application.

5.2.1.11.5 Multi-function (programmable) keysets.

5.2.1.11.5.1 Special criteria. Multi-function keysets require instrumentation for accommodating switching at two levels: a gross function, or mode level and a detailed, or item level within each mode.

MIL-HDBK-759B

5.2.1.11.5.1.1 Function (or mode) selection. The amount of selection capability should be dependent upon the number of different sets of switching functions to be used alternatively. The mechanization of the function selectors should ordinarily be by rotary selector or by interlocked push buttons with latching actuation. The complete range of choices as well as the current mode indication should be visible to the operator at all times, except in those instances where function selectors are implemented by entry of coded switching instructions using a general-purpose keyboard. (Mode switching also may be implemented for initiation by the computer, in which case manual switching capability can be correspondingly reduced.)

5.2.1.11.5.1.2 Switching for item selection. The amount of selection capability should be dependent upon the number of switching actions which should be independently controllable. Item selection should be provided by push buttons of the appropriate types (latching or momentary; interlocked or independent) for the specific switching functions.

5.2.1.11.5.1.3 Item labeling and feedback. Item labels applicable to each mode should be displayed on or adjacent to the item selector switches, and labels which are inapplicable to the selected mode should not be visible. Appropriate feedback should be provided to indicate the current state of each item selector switch. When switching to a new mode, feedback should be provided as to the current state of each switchable function. In addition, feedback may be needed to indicate which switches can or cannot be utilized in the current mode (by extinguishing labels for switching functions which are inapplicable).

5.2.1.11.5.2 Configuration. The physical configuration of the keyset should be appropriate to the switching functions it should handle and to the operator's task. A sample configuration is shown in Figure 14.

5.2.1.11.5.3 Dimensions, displacement, and separation. The push button switches used in multi-function keysets should conform to the dimensional criteria for push buttons (see 5.2.1.10) as applicable.

5.2.1.11.5.4 Mounting. Multi-function keysets may be mounted wherever they are conveniently available for use.

5.2.1.11.5.5 Actuating force. The actuating force for the push buttons in multi-function keysets should fall in the range of 0.25 N to 11.3 N. The larger actuating forces should be used only with large-size illuminated switchcaps 25 mm wide or larger which may be needed to accommodate switchcap labeling. The preferred actuating force is about 2.8 N.

MIL-HDBK-759B

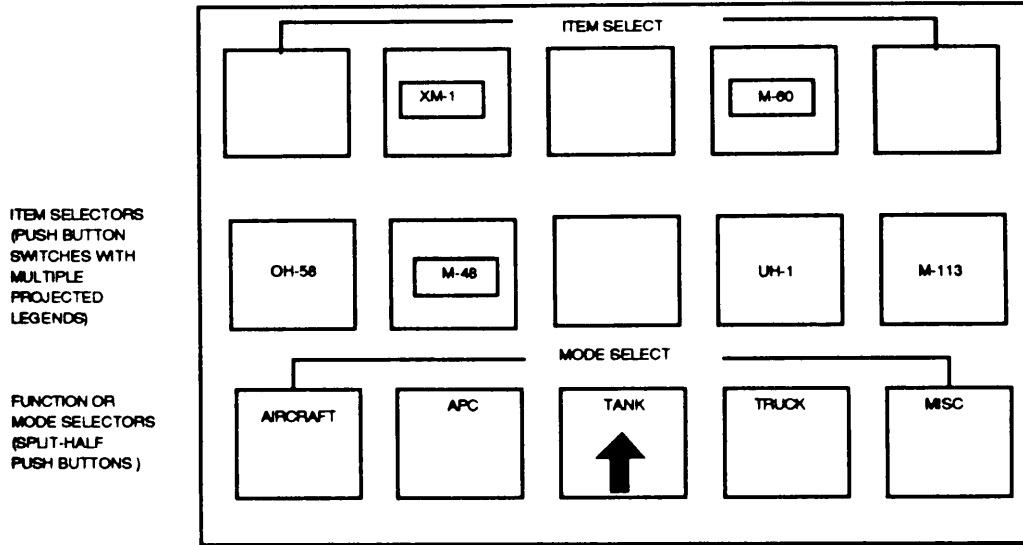

EXAMPLE 1
(VEHICLE MODE)

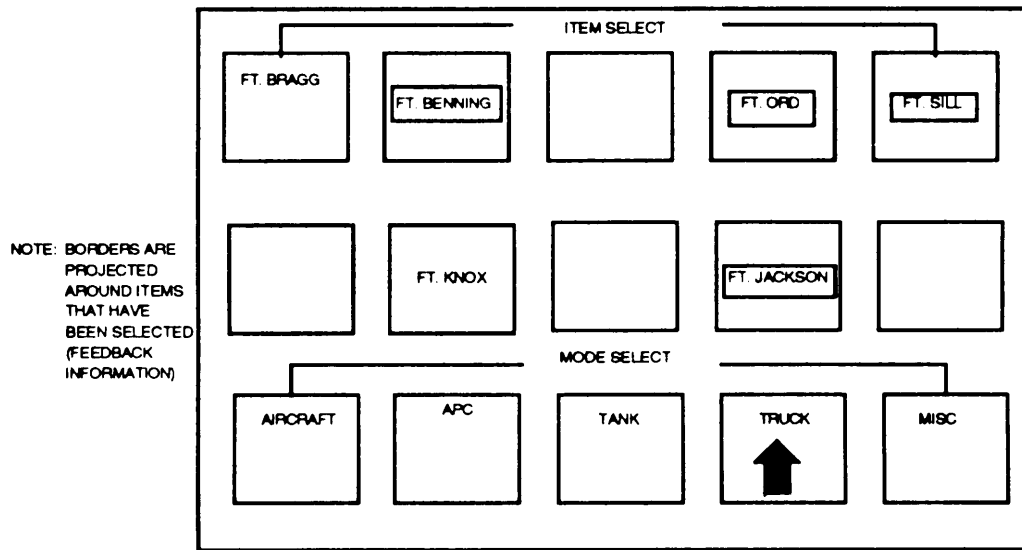

EXAMPLE 2
(INSTALLATION MODE)

FIGURE 14. Multi-function keyset format examples

MIL-HDBK-759B

5.2.1.11.6 Menu selectors.

5.2.1.11.6.1 Special criteria. Menu selectors require control at three levels: (1) function-level switching to select which one out of the set of menu listings is presented on the display, (2) a control for selection of a particular item from the menu, and (3) a control for entry or activation of the selected menu item. The function selector should be instrumented as in 5.2.1.11.5.1. Menu-item selection may implemented by means of a cursor controlled by push buttons, a light pencil, or a grid/stylus-type device. The entry instruction itself should be implemented as a separate momentary-contact switch.

5.2.1.11.6.2 Configuration. The physical configuration of menu selector controls and displays should be appropriate to the switching functions it should handle and to the operator's task. Two sample configurations are shown in Figure 15.

5.2.1.11.6.3 Dimensions, displacement, and separation. The push button switches should conform to dimensional criteria for legend switches (see 5.2.1.7). Thumbwheel control should conform to 5.2.1.12.1.2.4 or 5.2.1.12.1.2.7.4 if used.

5.2.1.11.6.4 Mounting. The cursor control (thumbwheel, keypad) should be mounted beneath the menu listing. The ENTER button should be close to and preferably to the right of the cursor control. The function (mode) selectors should be mounted conveniently near the cursor control.

5.2.1.11.6.5 Actuating force. Actuating force for push buttons and thumbwheel control should fall within ranges specified in 5.2.1.10.2 and 5.2.1.12.1.2.4.

5.2.1.11.6.6 Feedback. Feedback should be provided per 5.2.1.11.4.5 and 5.2.1.11.2.4. Some readily apparent means of differentiating selected menu items from non-selected items, such as underlining, should be employed.

5.2.1.12 Rotary controls.5.2.1.12.1 Discrete rotary controls.5.2.1.12.1.1 Rotary selector switches.

5.2.1.12.1.1.1 Application. Rotary selector switches should be used for discrete functions when three or more detented positions are required. Rotary selector switches should not be used for a two-position function unless prompt visual identification is of primary importance and speed of control operation is not critical.

MIL-HDBK-759B

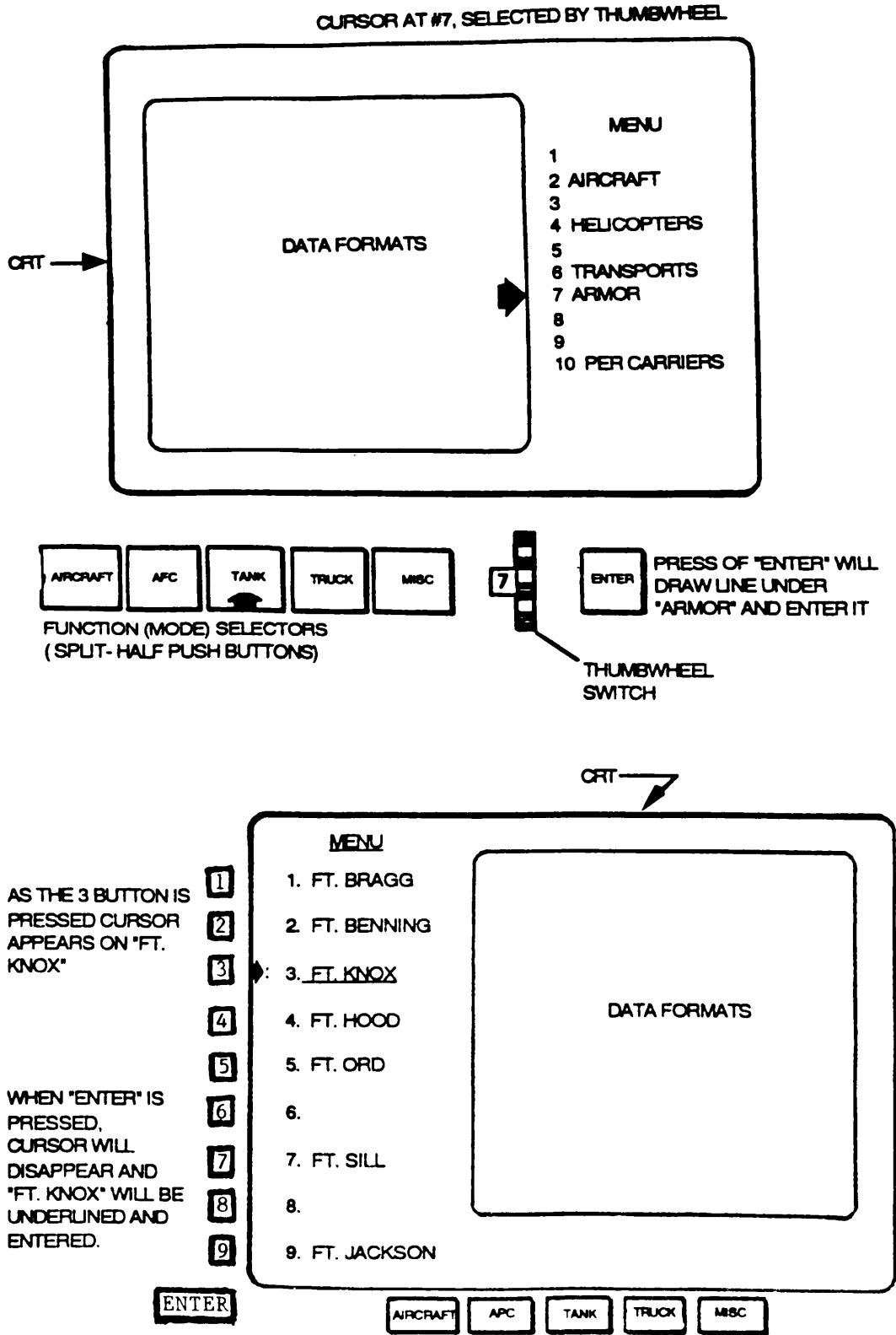

FIGURE 15. Menu selector types and format examples

MIL-HDBK-759B

5.2.1.12.1.1.2 Positive detents. Rotary selector switches should have mechanical detents so that the switch knob cannot be positioned between nominal switch positions.

5.2.1.12.1.1.3 Number of switch positions. A rotary selector switch which is not visible to the operator during normal system operation should have no more than 12 positions. A rotary switch that is constantly visible to the operator should have not more than 24 positions. Recommended switchsetting parameters are provided in Table 13. In addition, the following criteria should apply:

- a. Rotary switch positions should not be placed opposite each other unless knob shape precludes confusion as to which end of the knob is the pointer.
- b. Stops should be provided at the beginning and end of the range of control positions if the switch is not required to be operated beyond the end positions or specified limits.
- c. The switch resistance should be elastic, building up, then decreasing as each position is approached, so that the control "snaps" into position without stopping between adjacent positions.

TABLE 13. Knob detent placement

Total No. of Settings	Recommended Starting Position (Degrees)			Recommended Angular Displacement (Degrees)	Recommended Radius for 13 mm Separation (mm)
	Left-Hand Operation	Right-Hand Operation	Either Hand		
3	16.00	264.00	320.00	40.00	18.20
4	351.00	253.29	302.14	38.57	18.90
5	327.73	243.31	285.52	37.24	19.50
6	306.00	234.00	207.00	36.00	20.20
7	285.67	225.29	255.48	34.84	20.80
8	266.62	217.13	241.87	33.75	21.60
9	248.71	209.45	229.08	32.73	22.20
10	231.85	202.22	217.03	31.77	22.90
11	215.98	195.42	205.70	30.86	23.60
12	0, 90 or 180	180, 270 or 360	0 or 180	30.00	24.30

MIL-HDBK-759B

5.2.1.12.1.1.4 Torque for actuation. Rotary switch torque criteria should be compatible with the size of the control knob associated with it. For example, miniaturized switches with knob diameters of 25 mm or less should not require a torque greater than 226 mN•m to rotate the knob. Medium-sized knobs (25-50 mm) should not require torque greater than 678 mN•m, and large knobs (diameters 75 mm or greater) should not require torque greater than 1.13 N•m.

5.2.1.12.1.1.5 Knob shape. Bar or bar/pointer-shaped knobs should be used with rotary selector switches so that an operator can tell which way the knob is pointing, and so he can quickly identify a selector function from a continuously-adjustable control function. A white reference line should be inscribed on the face of the knob, running from approximately the midpoint of the knob to the pointing edge. The pointing end of the knob should also be tapered so that the pointing end is easily differentiated from the non-pointing end, and also so that the reference mark can be "followed" (visually) to a point adjacent to a reference mark or numeral on the interfacing panel. Contrast between the reference mark and its knob background should be at least 50%.

5.2.1.12.1.1.6 Blind positioning. When an application requires the operator to judge pointer position without benefit of visual reference, the sides of the knob (except for the tapered end) should be parallel. If additional shape coding is required, the code should be applied as an extra cap. The shape code should not interfere with the general shape objectives noted above.

5.2.1.12.1.1.7 Dimensions, displacement, and separation. Knob dimensions, switch displacement, and control separation should conform to criteria in Table 14 and Figure 16.

5.2.1.12.1.1.8 Knob mounting. Rotary selector knobs should be mounted so that the reference mark is sufficiently close to the reference panel markings so that visual parallax is minimized. When viewed from the normal operator's position, the parallax error should not exceed 25% of the distance between scale markings. Rotary selector knob attachment should preclude the possibility of the knob slipping on the shaft, and/or the knob being replaced with the pointing end opposite from its correct position.

5.2.1.12.1.1.9 Open-window, skirted knobs. Special knob designs consisting of a bar-type knob and open-window skirt may be used for applications in which visual confusion may be reduced by exposing only one number of a scale at a time (see Table 14).

5.2.1.12.1.2 Thumbwheel selector switches.

5.2.1.12.1.2.1 Use. Mechanically-detented thumbwheel controls may be used as an alternative rotary selector device when the application will benefit from the compactness of such devices, and appropriate visual and/or audio feedback is provided. Numeric thumbwheels should be oriented and move as indicated in Figure 17.

MIL-HDBK-759B

TABLE 14. Rotary selector controls

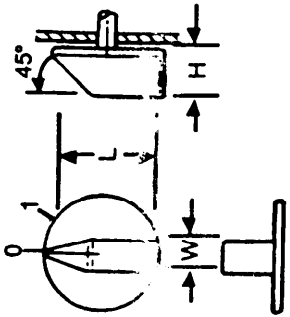
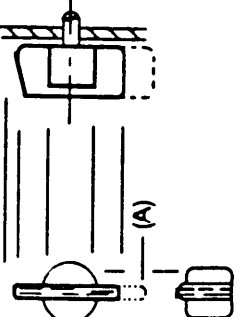
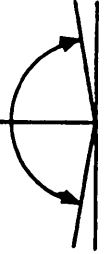
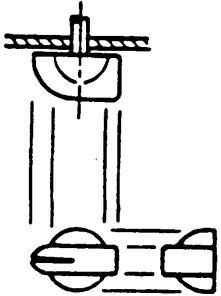
	DESIGN CRITERIA				SEPARATION
	APPLICATION CRITERIA	DIMENSIONS	DISPLACEMENT		
 <p>PREFERRED FOR ACCURATE IDENTIFICATION OF KNOB POSITION BY FEEL FOR USE ON ELECTRONIC, AIRCRAFT, AND AUTOMOTIVE CONTROL PANELS WHERE HIGH FORCE SWITCHES ARE NOT REQUIRED. SKIRT OPTIONAL.</p> <p>SWITCH RESISTANCE APPROX. MAX: $L = 38\text{mm} = (0.11 \text{ N}\cdot\text{m})$ $L = 50\text{mm} = (0.34 \text{ N}\cdot\text{m})$ $L = 100\text{mm} = (0.68 \text{ N}\cdot\text{m})$</p>	<p>L = 38 mm TO 100mm IF GLOVES ARE WORN, ADD 13mm</p> <p>W = 13mm TO 25mm</p> <p>H = 16mm TO 75mm</p>	<p>MIN = 15°; MIN FOR BLIND POS'N ID = 30°</p>	<p>SEE FIG. 16 FOR SIMULTANEOUS OPERATION OF ADJACENT KNOBS (TWO HANDS) ADD 25mm (38mm FOR GLOVES.)</p>		
 <p>ABOVE ACCEPTABLE CRITERIA APPLICABLE AS LONG AS KNOB POSITIONS REMAIN IN UPPER 160° HEMISPHERE</p>  <p>(A) EXTENDED TAIL HELPFUL FOR HIGHER TORQUE. USE ONLY WHEN POINTER MARKING CLEARLY VISIBLE.</p>	<p>SEE ABOVE</p>	<p>SEE ABOVE</p>	<p>SEE ABOVE</p>	<p>SEE ABOVE</p>	
 <p>ACCEPTABLE ALTERNATIVE TO A ABOVE.</p>	<p>SEE ABOVE</p>	<p>SEE ABOVE</p>	<p>SEE ABOVE</p>	<p>SEE ABOVE</p>	

MIL-HDBK-759B

TABLE 14. Rotary selector controls - continued

	APPLICATION CRITERIA	DESIGN CRITERIA			
		DIMENSIONS	DISPLACEMENT	SEPARATION	
	ACCEPTABLE ALTERNATIVE TO A ABOVE WHEN ONLY GROSS SETTING IS REQUIRED (MAJOR NUMBERED POSITIONS)	L = MIN 25mm OTHER SAME AS A	SEE ABOVE	SEE ABOVE	
	ACCEPTABLE ONLY FOR APPLICATIONS WHERE PANEL SPACE IS LIMITED, GLOVES NOT WORN, SWITCH RESISTANCE LESS THAN .042 N ^m	L = MIN 19mm W = MIN 6.5mm X = MIN 13mm	SEE ABOVE	25mm	
	FOR HEAVY DUTY, HIGH TORQUE SWITCHES: PREFERRED	L = MIN 100mm H = MIN 32mm	MIN = 10°	END TO END HANDLE SEPARATION = 75mm	
	ACCEPTABLE ALTERNATIVE	L1 = MIN 50mm D = SAME	SAME	SAME	

TABLE 14. Rotary selector controls - continued

	APPLICATION CRITERIA	DESIGN CRITERIA			
		DIMENSIONS	DISPLACEMENT	SEPARATION	
	<p>TACTILE CONTROL IDENTIFICATION, PREFERRED METHOD FOR ROTARY CONTROLS (SEE MS91528 FOR CODED CAP FORMS/COLORS)</p>	D = MIN 16mm	N/A	N/A	
		H = MIN 3.2mm TO 19mm			
	<p>TACTILE CAP FOR ROTARY SELECTOR KNOB</p>	SAME AS ABOVE			

MIL-HDBK-759B

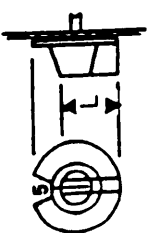
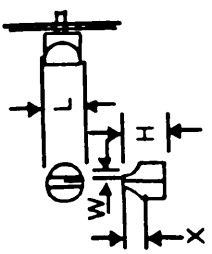
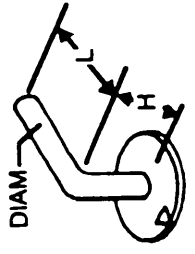
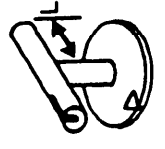
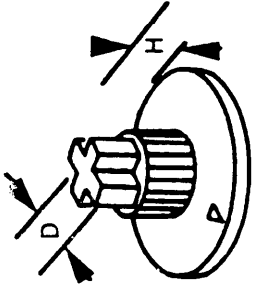
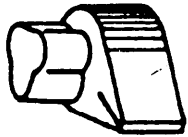
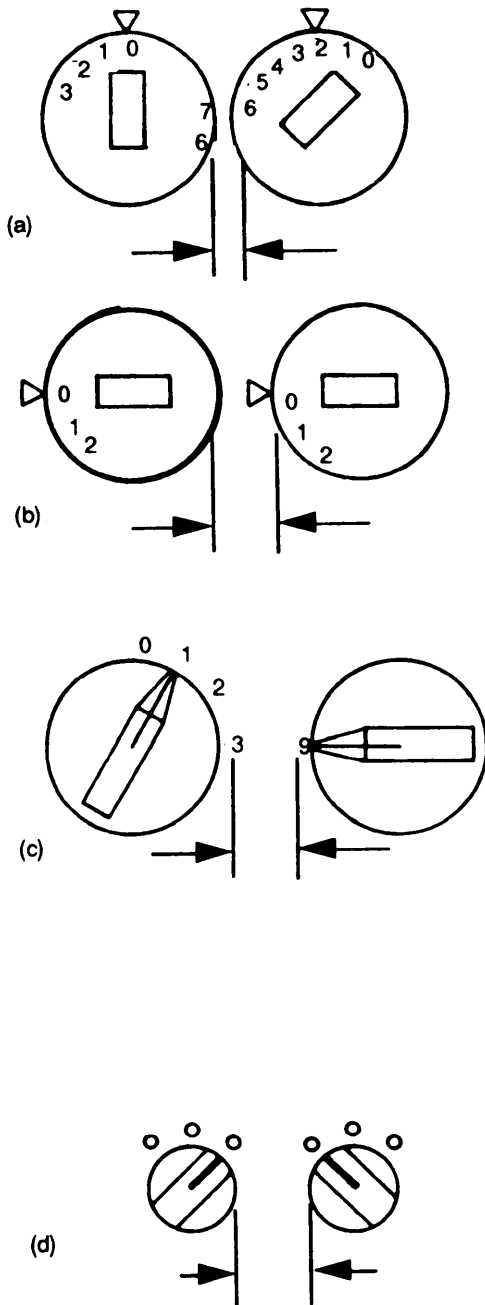

NOMINAL SEPARATION BETWEEN MOVING-POINTER KNOBS REQUIRES ONLY THAT THERE IS ADEQUATE PHYSICAL SEPARATION BETWEEN THE KNOB SKIRTS TO PREVENT KNOB MOVEMENT INTERFERENCE WHEN THE ZERO OR REFERENCING INDEX IS AT THE 12 O'CLOCK POSITION.

SEPARATION BETWEEN MOVING-POINTER KNOBS THAT HAVE THE REFERENCING INDEX AT THE 3 OR 9 O'CLOCK POSITION SHOULD BE SUFFICIENT TO ENSURE THAT THERE IS NOT VISUAL CONFUSION REGARDING KNOB TO WHICH THE INDEX MARK REFERS, MINIMUM SHOULD BE ABOUT TWICE THE NOMINAL CHARACTER WIDTH.

SEPARATION BETWEEN MOVING-POINTER/FIXED-SCALE CONFIGURATIONS SHOULD BE BASED ON CLEAR VISUAL SEPARATION OF ADJACENT SCALE CHARACTERS, THE MINIMUM SHOULD BE AT LEAST FOUR CHARACTER WIDTHS. HOWEVER, IF THE KNOB LENGTH EXTENDS THE FULL WIDTH OF THE SKIRT AND THE HANDLE IS NOT TAPERED AT THE POINTING END, THERE SHOULD BE AT LEAST A 25mm SEPARATION BETWEEN KNOBS WHEN THEY ARE END-TO-END.

SEPARATION BETWEEN SMALL, DETENTED KNOB CONFIGURATIONS AS SHOWN SHOULD BE AT LEAST 25mm UNLESS THERE ARE ADJACENT PANEL REFERENCING MARKS OR CHARACTERS, IN WHICH CASE SEPARATION MINIMUMS SHOULD BE ESTABLISHED ON THE BASIS OF (C) ABOVE, OR THE 25mm CRITERIA WHICHEVER IS GREATER.

FIGURE 16. Rotating knob separation

MIL-HDBK-759B

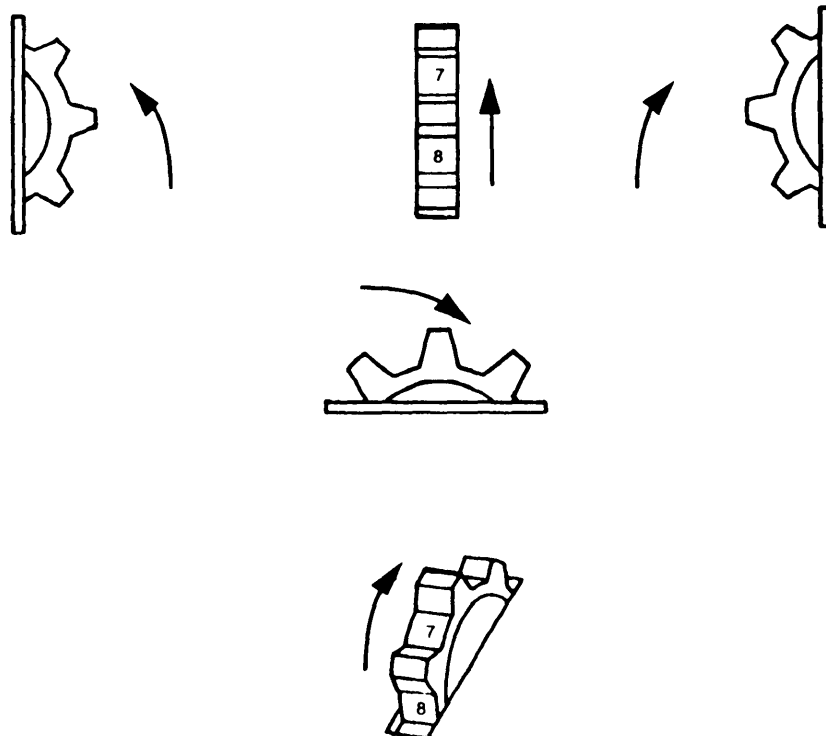

ARROWS INDICATE DIRECTION OF CONTROL MOTION TO PRODUCE A VALUE INCREASE

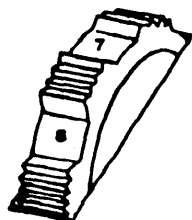

ALTERNATE RIM PATTERNS ARE ACCEPTABLE AS LONG AS THEY PROVIDE POSITION IDENTIFICATION AND AID IN MANIPULATION

FIGURE 17. Thumbwheel orientation and movement

5.2.1.12.1.2.2 Rim tabs and serrations. Raised tabs and/or serrated sections of the thumbwheel rim should be provided to aid the operator in identifying discrete positions and movement of the control.

5.2.1.12.1.2.3 Dimensions, separation, and resistance. Control dimensions, separation, and resistance should conform to criteria in Figure 18. Control resistance should be elastic, building up and then decreasing as each detent is approached so that the control “snaps” into position without stopping between adjacent detents.

MIL-HDBK-759B

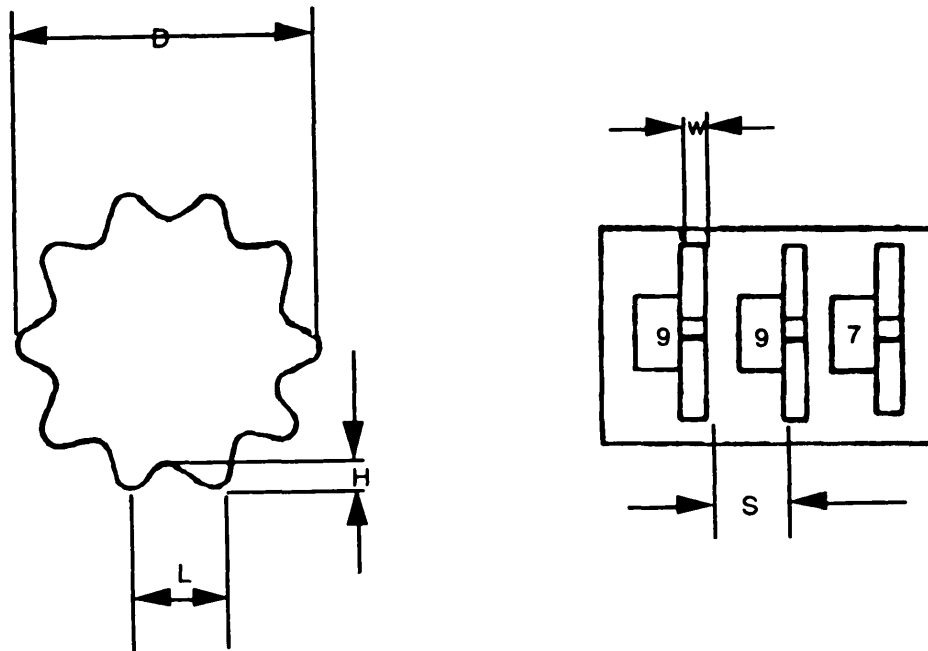

	D DIAMETER	L TROUGH DISTANCE	W WIDTH	H DEPTH	S SEPARATION	RESISTANCE
MINIMUM	30 mm	11 mm	3 mm	3 mm	10 mm	1.7 N
MAXIMUM	65 mm	19 mm		13 mm		5.6 N

FIGURE 18. Discrete thumbwheel control

5.2.1.12.1.2.4 Labeling and visibility. Marking and labeling of thumbwheel controls should conform to criteria herein with respect to visibility of markings and design of numerals.

5.2.1.12.1.2.5 Color Coding. Thumbwheel controls may be coded by means of color and/or contrast (dark vs light surfaces). Examples are reversing the colors of the least significant digit wheel as on a typical odometer, and where used as an input device, the thumbwheel switch OFF or NORMAL positions may be color coded to permit a visual check that the digits have been reset to their normal value.

MIL-HDBK-759B

5.2.1.12.1.2.6 Continuous Adjustment Thumbwheel Controls.

5.2.1.12.1.2.6.1 Use. Continuously-adjustable thumbwheel controls may be used as an alternate to rotary knobs when the application will benefit from the compactness of the thumbwheel device.

5.2.1.12.1.2.6.2 Orientation and movement. Thumbwheels should be oriented and move in the directions specified in Figure 17.

5.2.1.12.1.2.6.3 Thumbwheel serrations. The rim of the thumbwheel should be serrated to aid the operator in manipulating the control.

5.2.1.12.1.2.6.4 Dimensions, separation, and resistance. Thumbwheel dimensions, separation, and resistance should conform to criteria in Figure 19.

5.2.1.12.1.2.6.5 Labeling and visibility. Marking and labeling of continuously-adjustable thumbwheel controls should conform to criteria herein with respect to visibility of markings and legibility of label alphanumerics.

5.2.1.13 Discrete controls.5.2.1.13.1 Toggle switch controls.

5.2.1.13.1.1 Application. Toggle switches may be used for functions which require two discrete positions or where space limitations are severe. They may also be used for three discrete positions, but a rotary selector or push button array is usually preferred for this application.

5.2.1.13.1.2 Prevention of accidental activation. When the prevention of accidental activation is of primary importance (critical, dangerous, or hazardous conditions would result), channel guards, lift-to-unlock switches, or any other equivalent means should be provided.

5.2.1.13.1.3 Dimensions, displacement, and separation. Dimensions, displacement, and separation between adjacent toggle switches should conform to the criteria in Table 15.

5.2.1.13.1.4 Resistance. Except for the case of a three-position, spring-centering switch, toggle switches should “snap” into position, with an audible “click” to provide positive feedback that the switch has been activated properly. The resistance should gradually increase, then drop as the switch snaps into position. The switch should not be capable of being stopped between positions. The range of resistance should be between 2.8N to 11 N depending on the length of the switch handle.

MIL-HDBK-759B

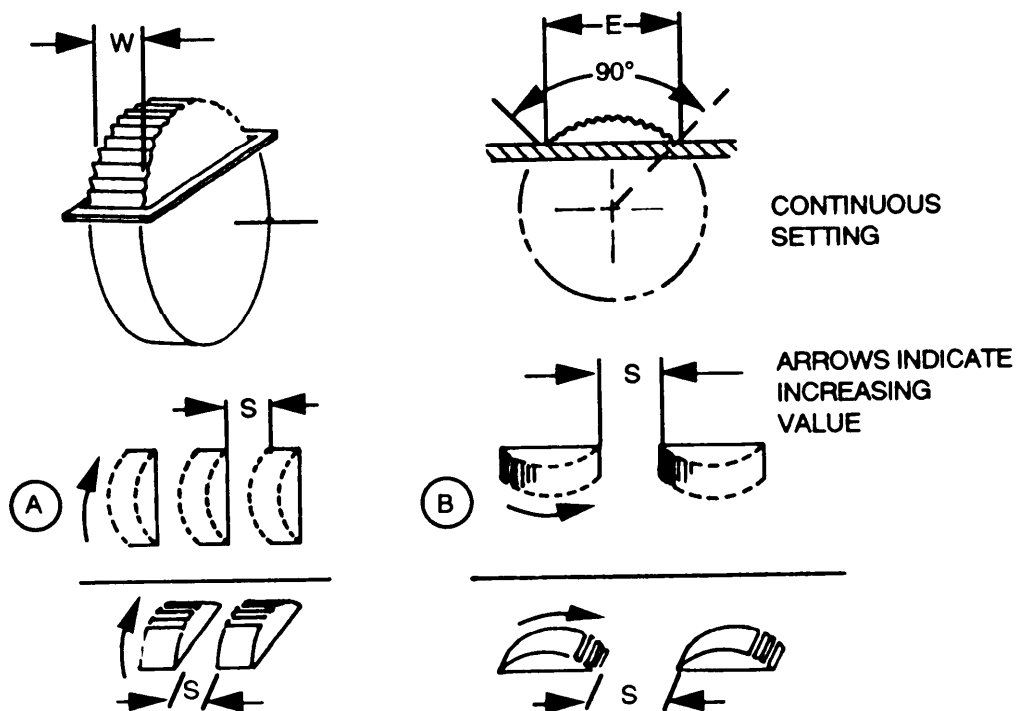

	RIM EXPOSURE E	WIDTH W	SEPARATION-S		RESISTANCE
			A	B	
MINIMUM	25 mm*	3.2mm*	25mm ADD 13mm FOR GLOVES	50mm ADD 25mm FOR GLOVES	TO MINIMIZE EFFECTS OF INADVERTENT INPUT IF OPERATOR SUBJECT TO MOTION
MAXIMUM	100mm	23mm	N/A	N/A	3.3N

*PREFERRED. SOME MINIATURE APPLICATIONS MAY REQUIRE LESS.

FIGURE 19. Thumbwheel adjustment controls

TABLE 15. Toggle switches







		DESIGN CRITERIA			
APPLICATION CRITERIA		DIMENSIONS	DISPLACEMENT	SEPARATION	
	MINIATURE TOGGLE SWITCH: LIMIT USE TO INDOOR APPLICATIONS WHERE LIMITED PANEL SPACE PRECLUDES STANDARD SIZE COMPONENTS.	D - MIN DIAM = 3.3mm	L - MIN LENGTH = 13mm		
	STANDARD CONFIGURATION: USE LARGER SIZES FOR APPLICATIONS WHERE GLOVED OPERATION IS LIKELY.	D - MIN DIAM = 4.5mm MAX = 7.8mm	LENGTH MIN - 13mm MAX - 50mm		
	BALL CAP DESIGN APPLICABLE WHERE FIRM GRASP OF TOGGLE IS NEEDED BECAUSE OF VEHICLE/OPERATION OSCILLATION.	D - MIN DIAM = 4.5mm MAX = 7.8mm*	SAME AS ABOVE		
	FLAT OR APPLIED TAB HANDLES PROVIDE IMPROVED VISUAL POSITION REFERENCE WHEN OPERATIONALLY IMPORTANT.			W - MIN HANDLE WIDTH = 4.5mm	
	APPLIED TAB HANDLE PROVIDES MEANS FOR COLOR CODING.			W - 10mm PREFERRED (MIN = 4.8mm MAX = 19mm)	
	ALTERNATE TO ANY STD SIZE CONFIGURATION ABOVE.			SAME AS ABOVE	
					*NOTE: ADD 13 mm FOR GLOVES

TABLE 15. Toggle switches - continued

		DESIGN CRITERIA		
APPLICATION CRITERIA		DIMENSIONS	DISPLACEMENT	SEPARATION
	TYPICAL TWO-STEP INTER-LOCKING SAFETY SWITCH.	D - MIN = 10mm		SHOULD NOT BE CLOSER THAN 50mm TO OTHER TO CONTROL OR STRUCTURE
				MAY BE SPACED (HORIZONTALLY) AS CLOSE AS 13mm. 25mm FOR GLOVES

TABLE 15. Toggle switches - continued

		DESIGN CRITERIA	
APPLICATION CRITERIA		DIMENSIONS	SEPARATION
 <p>TWO-POSITION SWITCHES ONLY WHEN VISUAL RECOGNITION OF SWITCH POSITION MANDATORY.</p>		D - DISPLACEMENT ANGLE MIN = 25°	<p>S - CTR - CTR* MIN = 19mm</p> <p>MAX FOR SIMULTANEOUS, MULTI-FINGER USE = 28mm</p> <p>S - MIN = 25mm</p>
	 <p>THREE-POSITION SWITCHES.</p>		
<p>SIDE BY SIDE ARRANGEMENT VERTICAL DISPLACEMENT.</p>			
<p>TIP TO TIP SEPARATION</p>			
<p>VERTICAL ARRAYS</p>			

*NOTE: ADD 13mm FOR GLOVES.

TABLE 15. Toggle switches - continued

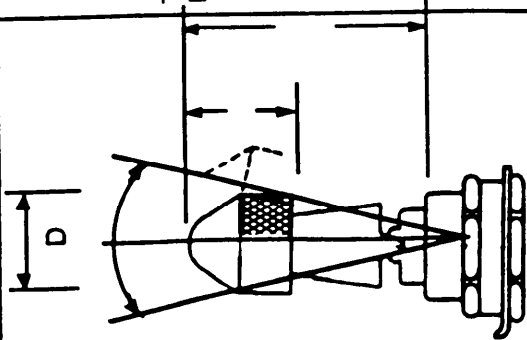
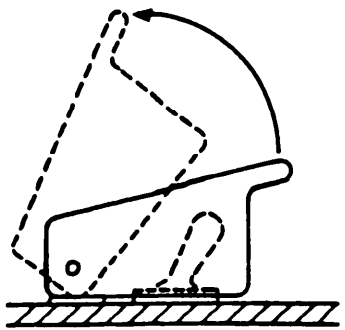
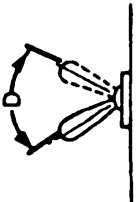
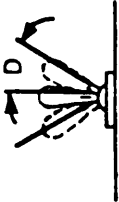
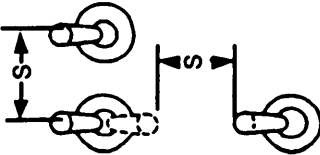
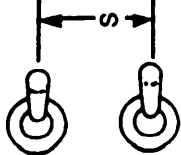
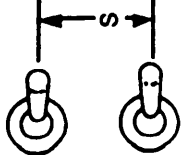
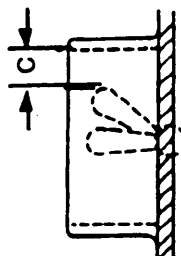
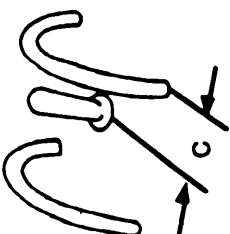
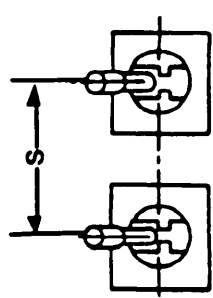
		DESIGN CRITERIA		
APPLICATION CRITERIA		DIMENSIONS	DISPLACEMENT	SEPARATION
	<p>GUARD SWITCHES WHERE ACCIDENTAL DISPLACEMENT OF A SWITCH MAY BE UNDESIRABLE (NOT NECESSARILY DANGEROUS)</p>	<p>C - TIP-GUARD FINGER CLEARANCE = MIN 13mm</p>		
		<p>C - MIN = 25mm 32mm FOR GLOVES</p>		
	<p>USE TWO-MOTION SAFETY SWITCH WHEN SWITCH-USE ERROR COULD LEAD TO DANGEROUS CONSEQUENCE (PULL TO OPERATE)</p>			<p>S - MIN = 25mm (50mm PRE-FERRED) ADD 13mm FOR GLOVES</p>

MIL-HDBK-759B

5.2.1.13.1.5 Switch orientation. Toggle switches used for ON-OFF functions should be oriented so that the handle moves in a vertical plane unless there is a special requirement for the switch to move laterally (due to a lack of panel space, to reflect a left-to-right relationship to some display). The ON position should be up, forward, or to the right. When toggle switches are located on panels that slope as in “wrap-around” or “stacked” workplace arrangements, switch orientation and movement should conform to criteria in Figure 20.

5.2.1.13.2 Rocker switch controls.

5.2.1.13.2.1 Application. Rocker switches may be used for functions which require two discrete positions, as an alternate to toggle switches. They should be considered for applications where the toggle switch handle protrusion might snag the operator’s sleeve or phone cord, or where there is insufficient panel space for separate labeling of switch positions. (Rocker switches are somewhat vulnerable to accidental operation by brushing-type contacts, however.) Rocker switches with three positions should be used only where the use of a rotary or legend switch control, for example, is not feasible or when the rocker switch is of the spring-loaded center-off type.

5.2.1.13.2.2 Dimensions, displacement, and separation. Dimensions, displacement and separation between adjacent rocker switches should conform to the criteria in Figure 21.

5.2.1.13.2.3 Resistance. The switch should “snap” into position, with an audible “click” to provide positive feedback that the switch has been activated properly. Resistance should gradually increase, then drop as the switch snaps into position. The switch should not be capable of being stopped between positions. The range of resistance should be between 2.8N-11N.

5.2.1.13.2.4 Orientation. Rocker switches used for ON-OFF functions should be oriented so that the handle moves in a vertical plane, except in special cases where a lateral motion is to be related to a right-left display relationship. The ON position should be up, forward, or to the right.

5.2.1.13.2.5 Color and illumination. Alternate colors may be used to denote the ON and OFF portions of a rocker switch. Alternate illumination of either the ON or OFF switch position may be used to provide positive recognition of which position the switch is in.

5.2.1.14 Push-pull controls.

5.2.1.14.1 Applications. Push-pull controls may be used when two discrete functions are to be selected. However, such applications should be used sparingly and for applications in which such configurations are typically expected (vehicle headlight switch, choke). They may also be used in certain cases where limited panel space suggests a miniaturized knob that may be used to serve two related, but distinct functions such as an ON-OFF/Volume switch for a W monitor. A three-position push-

MIL-HDBK-759B

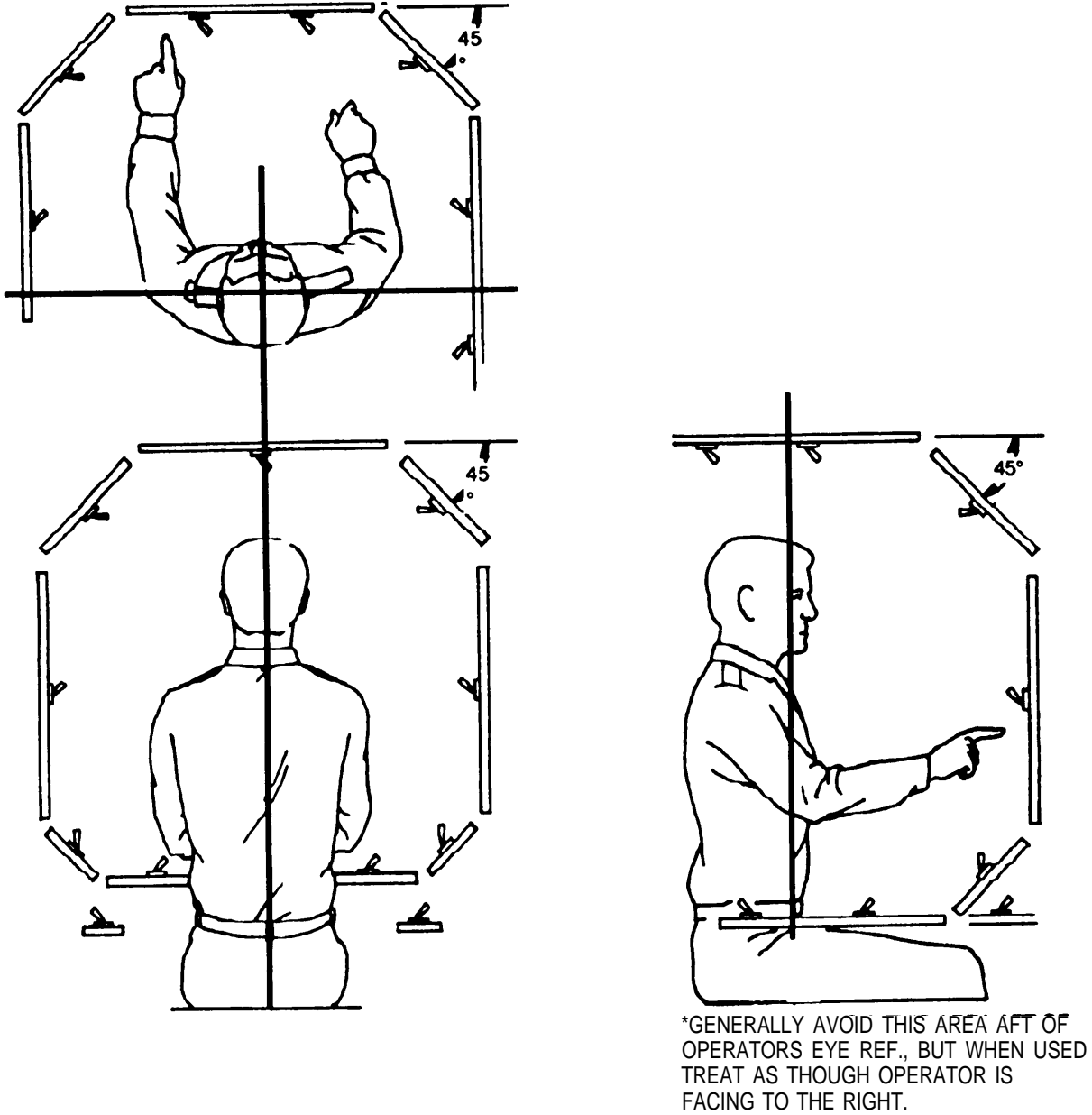
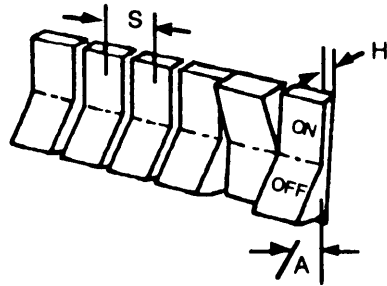
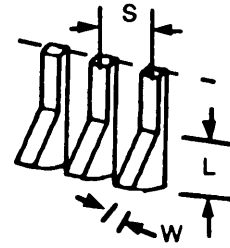

FIGURE 20. Toggle switch orientation for ON

MIL-HDBK-759B



STANDARD ROCKER SWITCH:
USE AS ALTERNATE TWO-POSN
TOGGLE SWITCH TO PROVIDE
LABELING SURFACE, EASE OF
COLOR CODING, SWITCH
ILLUMINATION.



NARROW WIDTH, ESPECIALLY
DESIRABLE FOR TACTILE
DEFINITION WITH GLOVES.

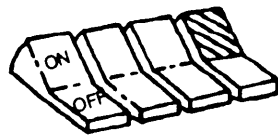

ALTERNATE (CONTRAST) COLOR
FOR ON VERSUS OFF TO PROVIDE
CONSPICUOUS CUE OF SWITCH
POSITION. ILLUMINATED "ON"
DESIRABLE AS SECOND FEEDBACK
CUE.

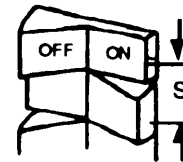

	DIMENSIONS		RESISTANCE
	W, WIDTH	L, LENGTH	
MINIMUM	6.5 mm	13mm	2.8 N 11,1 N
MAXIMUM			

	DISPLACEMENT		SEPARATION (CENTER-TO-CENTER)	
	H, HEIGHT DEPRESSED	A, ANGLE	S (BARE HAND)	S (GLOVED HAND)
MINIMUM	3 mm	30°	19mm	32 mm

FIGURE 21. Rocker switches

MIL-HDBK-759B

pull control is acceptable in isolated instances where the critical nature of inadvertent selection of the wrong position has no serious consequences. The typical vehicle headlight switch configuration that provides three “pull” positions (e.g., OFF/Park Headlight) plus a rotary panel light and dome light switch is an example.

5.2.1.14.2 Handle dimensions, displacement and clearances. Push-pull control handles should conform to criteria in Table 16.

5.2.1.14.3 Rotation. Except for combination push-pull/rotate switch configurations, push-pull control handles should be keyed to the shaft so they do not rotate, unless the control is to be used for a special handbrake application in which the handle is rotated to disengage the brake setting. When the control system provides a combination push-pull/rotate functional operation, and a round knob style is used, the rim should be serrated to denote (visually and tactually) that the knob has the capability of being rotated and to facilitate a slip-free finger grip.

5.2.1.14.4 Detents. Mechanical detents should be incorporated into push-pull control configurations and these should provide sufficient tactile indication of positions that the operator is not in doubt as to when the control is “in-position.”

5.2.1.14.5 Snagging and inadvertent contact. The following considerations should be used in determining whether to use push-pull type controls, where they should be located and in what direction the operating axis should be:



- a. possibility of bumping a control while getting into or out of the operator position (such as in a vehicle),
- b. possibility of snagging clothing, communication cables, or other equipment items on the control,
- c. possibility of inadvertently deactivating the control setting as the operator reaches for another control.

5.2.1.14.6 Direction-of-control motion. Control direction should be as follows:

- a. pull towards the operator for ON or activation; push away for OFF or deactivation;
- b. rotate to the right for activation or increasing function in the case of combination pull/rotary switches. An exception should be permitted in the case of certain contemporary automotive switches (combination headlight, parking light and panel/dome light switch).

5.2.1.14.7 Resistance. Preferred maximum forces for pulling a panel control with fingers is 18 N and for pulling a T-bar with four fingers is 45 N.

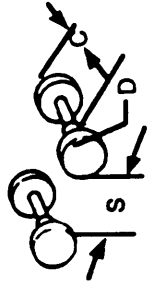
TABLE 16. Push-pull controls

		DESIGN CRITERIA			
		APPLICATION CRITERIA	DIMENSIONS	DISPLACEMENT	SEPARATION
	<p>PUSH-PULL CONTROL, LOW RESISTANCE, FOR TWO-POSITION, MECHANICAL AND/OR ELECTRICAL SYSTEMS.</p> <p>ALTERNATE THREE POSITION PLUS ROTARY FUNCTION ACCEPTABLE FOR APPLICATION SUCH AS VEHICLE HEADLIGHT PLUS PARKING LIGHTS, PANEL AND DOME LIGHTS. PROVIDE SERRATED RIM.</p>	<p>D, MIN DIAM: 19mm</p> <p>C, MIN CLEARANCE: 25mm ADD 13mm FOR GLOVED HAND</p>	<p>25+/- 13mm MIN BETWEEN PULL POSNS: 13mm</p>	<p>S, MIN SPACE BETWEEN: 38mm ADD 13mm FOR GLOVED HAND</p>	
	<p>ALTERNATE HANDLE; MINIATURE ELECTRICAL PANEL SWITCH ONLY. AVOID GLOVE USE APPLICATION.</p>	<p>N/A</p>	<p>L, MIN LGTH: 19mm</p>	<p>S, MIN SPACE BETWEEN: 25mm</p>	
	<p>HIGH-FORCE PUSH-PULL FOR TWO-POSITION MECHANICAL SYSTEM ONLY.</p>	<p>D, MIN DIAM: 6.5mm</p> <p>W, MIN WIDTH: 100 mm</p> <p>D, DEPTH: 16-38mm</p>	<p>C, MIN CLEARANCE: 38mm ADD 6mm FOR GLOVED HAND</p>	<p>MINIMUM: 13mm</p> <p>MINIMUM: 25mm PREFERRED: 50mm</p>	
	<p>SAME AS ABOVE. PREFERRED WHERE POSSIBLE GARMENT OR CABLE-SNAG POSSIBILITY EXISTS.</p> <p>NOTE: 1 & 2 FINGER PULLS ALSO ACCEPTABLE FOR LESS THAN 18 N APPLICATIONS.</p>	<p>W, MIN WIDTH: 100mm</p> <p>D, DEPTH: 16-38mm</p>	<p>C, MIN CLEARANCE: 38mm</p>	<p>S, MIN SPACE BETWEEN: 13mm</p>	

MIL-HDBK-759B

5.2.1.15 Printed circuit (PC) switch controls.

5.2.1.15.1 Use. PC switches may be used when manual programming functions are required in systems which employ printed circuit boards.

5.2.1.15.2 Dimensions, resistance, displacement, and separation. Dimensions, resistance, displacement, and separation between adjacent PC switch actuators should conform to the conditions listed below.

- a. Dimensions of actuators should be sufficiently high to permit error-free manipulation by the operator when using some commonly available stylus (pencil or pen). The design of the actuators should not require the use of a special tool for manipulation.
- b. Actuator resistance should be sufficiently high to avoid inadvertent activation under expected use conditions. Resistance should gradually increase, then drop when the actuator "snaps" into position. The actuator should not be capable of stopping between positions.
- c. When actuators are slide-type, they should have sufficient travel (displacement) to permit easy recognition of switch setting. At a minimum, the travel should be twice the length of the actuator. When actuators are rocker-type, the actuated wing should be flush with the surface of the module.
- d. Actuators should have sufficient separation to permit error-free manipulation by the operator. (The stylus cannot inadvertently contact adjacent actuators.)

5.2.1.15.3 Shape. The surface of the actuator should be indented to accept the point of the stylus. The indentation should be sufficiently deep to avoid slippage of the stylus during manipulation.

5.2.1.16 Integral, handle-mounted controls.5.2.1.16.1 General.

5.2.1.16.1.1 Application. Handle-mounted, auxiliary controls may be integrated into the handles of primary controllers such as joysticks, or equipment such as cameras and power tools, when such integration enhances the simplicity and/or efficiency and safety of system operation.

5.2.1.16.1.2 Number of controls. The number of controls integrated into a handle should not exceed three (a trigger, plus two thumb-operated switches in a joystick handle) unless specified by the procurement specification or upon specific approval by the acquiring activity.

5.2.1.16.1.3 Inadvertent input. The type of auxiliary switch, its motion characteristics and location should be such that movement of the auxiliary switch will cause minimal probability that the primary control or equipment operation and/or positioning is inadvertently disturbed.

MIL-HDBK-759B

5.2.1.16.2 Thumb switches.

5.2.1.16.2.1 Switch types. Push buttons, slide, or rotary thumb switches may be used as appropriate for any of the following switch modes:

- a. Push button: ON-OFF (communication).
- b. Two-dimensional toggle: two-axis, spring-centering (aircraft trim).
- c. Slide switch: single-axis ON-OFF, momentary ON plus ON-HOLD (safety switch for hand-held power tool).
- d. Rotary thumbwheel: rotary selector (maximum of three positions), continuous adjustment (audio volume).

Other auxiliary thumb-operated control applications should be subject to the approval of the acquiring activity.

5.2.1.16.2.2 Location and operation. Thumb switches should be positioned and operate in a fashion that is compatible with comfortable and natural thumb articulation limits, considering the total range of hand sizes for the expected user population, and constraints imposed by wearing of gloves.

5.2.1.16.2.3 Resistance. Resistance should not exceed limits for push buttons, slides, or thumbwheels as specified in other sections of this handbook.

5.2.1.16.2.4 Dimensions and displacement. Dimensions and displacement of handle-mounted, switches should conform to criteria in Table 17.

5.2.1.16.3 Index finger-operated switches and triaers.

5.2.1.16.3.1 Application. Index finger-operated, auxiliary, handle-mounted controls should be used for typical "trigger" operations (weapon firing, camera film operation, and power tool motor activation). Since the operator typically expects to use the index finger for these types of functions, other index finger operations should not be implemented without express approval of the acquiring activity. Similarly, "trigger" functions should not be implemented in the form of non-index finger operation (thumb or palm).

5.2.1.16.3.2 Location and operation. Trigger controls should be located and operate in a manner that is compatible with the inherent limitations for using the basic control handle. (The operator should not be required to shift his hand from the normal hand-grip position in order to actuate the trigger.) If the trigger should be operated simultaneously while holding another auxiliary switch (safety), location and operation of both controls should be such that the operator can comfortably and naturally activate both controls without inadvertently disturbing the primary handle positioning or aiming. Special consideration should be given to restrictions which may be imposed by wearing of gloves (reach and mobility).

MIL-HDBK-759B

5.2.1.16.3.3 Resistance. Trigger-pull characteristics, including resistance level and profile, should be as specified by the acquiring activity. Unless otherwise directed by the acquiring activity, trigger response should be “even” throughout the trigger pull, i.e., breakout vs steady-state should be approximately equal with no apparent “build-up” prior to final contact with the mechanical stop.

5.2.1.16.3.4 Safety. Inadvertent trigger operation should be minimized through proper use of trigger guards, safety latches, or other means to prevent inadvertent operation during non-operating modes (storing or carrying) and inadvertent operation during primary firing or operating modes (trigger activation before the operator is prepared).

5.2.1.16.3.5 Dimensions, displacement, and clearance. Trigger dimensions, displacement, and clearance limits should conform to criteria in Table 17.

5.2.1.16.4 Grip-actuated switches.

5.2.1.16.4.1 Application. Handle-mounted grip switches should be used only for discrete ON-OFF enabling functions with respect to a trigger mechanism, or control outputs from a joystick.

5.2.1.16.4.2 Dimensions, displacement, and resistance. The grip-actuated switch should be compatible with the natural placement and contour of the operator's palm, as it conforms to the handle during use of the primary handle manipulation (for moving a joystick and positioning a tool or camera). The switch tab should be approximately 7.5 mm long by 9.5 mm wide and have rounded edges. Switch displacement should be between 3 mm and 6 mm. Resistance should not exceed 22.5 N nor be less than 3 N.

5.2.1.17 Slide switch controls.

5.2.1.17.1 Application. Slide switch controls may be used for functions which require two discrete positions. Slide switch controls may also be used for functions which require a higher number of discrete positions in which the switches are arranged in a matrix to permit easy recognition of relative switch settings (audio settings across frequencies), but should not be used where mispositioning is to be avoided.

5.2.1.17.2 Accidental activation. When the prevention of accidental activation is of primary importance (critical, dangerous, or hazardous conditions would result), channel guards or other equivalent means should be provided.

MIL-HDBK-759B

TABLE 17. Grip switches

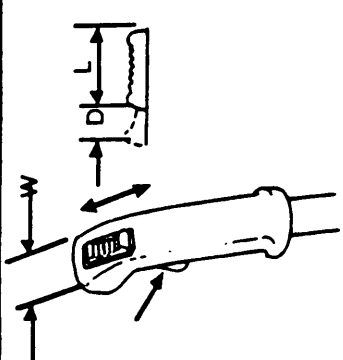
		DESIGN CRITERIA			SEPARATION	
		APPLICATION CRITERIA	DIMENSIONS	DISPLACEMENT		
	<p>THUMB-ACTUATED SWITCH, TWO OR THREE POSITION, SINGLE AXIS: TYPICAL APPLICATION IS SUPPLEMENTAL ON-OFF FUNCTION COUPLED TO PRIMARY CONTROL GRIP. CONCAVE CONTACT SURFACE WITH SERRATION DESIRABLE.</p>	<p>L-MIN SW LENGTH = 16mm</p>	<p>W - MIN WIDTH = 6.5mm</p>	<p>D - MIN = 6.5mm MAX = 19mm</p>	<p>N/A</p>	
	<p>INDEX FINGER OPERATED TRIGGER: APPLICATIONS INCLUDE HAND WEAPONS, AND JOY STICK WEAPON FIRING CONTROL, SLIGHT CONCAVE SURFACE DESIRABLE.</p>	<p>L - MIN = 25mm</p>	<p>SAME AS ABOVE</p>	<p>A - PREFERRED ANGLE BETWEEN 30° AND 45°</p>	<p>D - MIN = 3.2mm MAX = 16mm</p>	<p>S - GRIP/ TRIGGER CENTER SPACING = 50 +/-6mm</p>
	<p>THUMB-OPERATED, TWO-DIMENSIONAL SW, SPRING-CENTERING: TYPICAL APPLICATION TRIM CONTROL SWITCH CAP SHOWN IS TYPICAL.</p> <p>REF: MS87017 FOR SPECIAL HELICOPTER GRIP SWITCH REQUIREMENTS.</p>	<p>D - DIAM = 19 +/-6mm</p>	<p>H = 19 +/-6mm</p>		<p>D - MIN = 6.5mm MAX = 19mm</p>	<p>N/A</p>

MIL-HDBK-759B

TABLE 17. Grip switches - continued

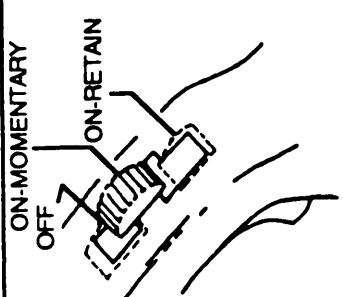
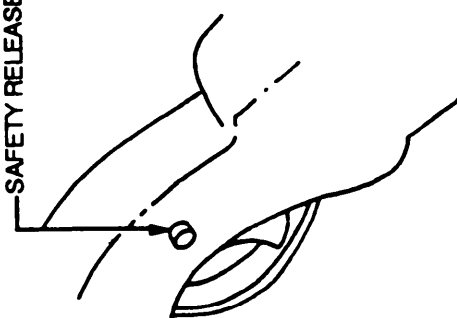
	APPLICATION CRITERIA	DESIGN CRITERIA		
		DIMENSIONS	DISPLACEMENT	SEPARATION
	<p>ACTIVE THUMB-OPERATED SAFETY/TRIGGER CONTROLS</p> <p>MECHANICAL THUMB SWITCH GUIDE (SPRING-LOADED, MOMENTARY-TO-OFF). MUST HAVE THUMB SWITCH IN MOMENTARY OR RETAIN, TO ACTIVATE TRIGGER.</p>			
	<p>MOMENTARY SAFETY BUTTON (MUST BE HELD TO ACTIVATE TRIGGER).</p>			

MIL-HDBK-759B

5.2.1.17.3 Dimensions, resistance, and separation. Dimensions, resistance, and separation of slide switch handles should conform to criteria in Figure 22. Detents should be provided for each control setting. Resistance should gradually increase then drop when the switch snaps into position. The switch should not be capable of stopping between positions.

5.2.1.17.4 Orientation. Where practicable, slide switches should be vertically oriented with movement of the slide up or away from the operator turning the equipment or component on, causing a quantity to increase, or causing the equipment or component to move forward, clockwise, to the right or up. Horizontal orientation or actuation slide switches should be employed only for compatibility with the controlled function or equipment location.

5.2.1.17.5 Positive indication. Slide switch controls involving more than two positions should be designed to provide indication of control setting, preferably a pointer located on the left side of the slide handle.

5.2.1.18 Two-axis controllers for display system applications.

5.2.1.18.1 General. Display systems requiring a single operator to make control movements along two orthogonal coordinate axes simultaneously should utilize one of the following types of controllers: simultaneously-operated hand cranks, ball control, joystick, grid and stylus devices, pantographs, or free-moving xy controller (mouse). Selection should be made on the basis of matching controller characteristics with system criteria (see Table 18 and 5.2.1.18.2 through 5.2.1.18.9).

5.2.1.18.2 Simultaneously-operated hand cranks.

5.2.1.18.2.1 Application. Simultaneously-operated hand cranks should be used in preference to other two-axis controllers where extreme precision is required in setting cross hairs or reticles as in map readouts or optical sighting mechanisms. This type of control may also be used in other applications requiring x and y control provided there is no criteria for rapid or frequent operation.

MIL-HDBK-759B

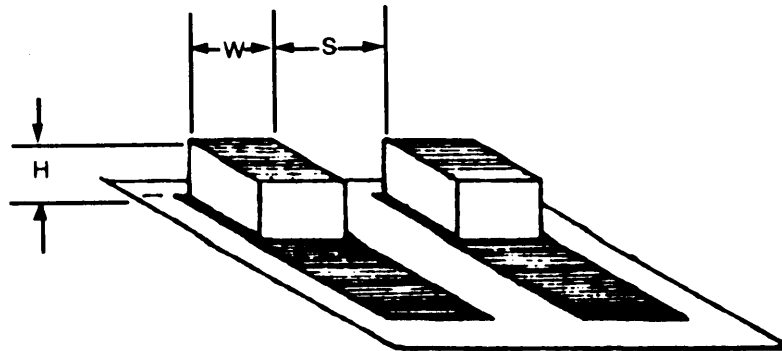

	DIMENSIONS		RESISTANCE	
	H ACTUATOR HEIGHT	W ACTUATOR WIDTH	SMALL SWITCH	LARGE SWITCH
MINIMUM	6.3 mm*	13 mm**	2.8 N	2.8 N
MAXIMUM	--	--	4.5 N	11 N

	SEPARATION, S		
	SINGLE FINGER OPERATION	SINGLE FINGER SEQUENTIAL OPERATION	SIMULTANEOUS OPERATION BY DIFFERENT FINGERS
MINIMUM	19 mm	13 mm	16 mm
OPTIMUM	50 mm	25 mm	19 mm

*Use by bare finger.

**Use with heavy handwear.

FIGURE 22. Slide switches

MIL-HDBK-759B

TABLE 18. Two-axis controllers for display system applications

Type of Controller	Control Order Utilized	Acceptable Display Applications			
		XY Data Pickoff	Continuous Tracking	Free-Drawn Graphics	Setting Cross Hairs
Simultaneously-operated hand cranks	Position	Not Recommended	Not Recommended	Not Recommended	Good
Ball control	Position	Good	Fair	Poor	Good
Isometric joystick (Shift stick)	Position, Rate-Aided	Good	Good	Fair	Fair
Isotonic joystick (displacement stick)	Position, Rate-Aided	Good	Good	Good	Fair
Grid and stylus devices	Position	Good	Fair	Good	Good
Free-moving XY controller (mouse)	Position	Good	Not Recommended	Not Recommended	Fair
Light pen (augmented)	Position	Good	Fair	Good	Fair

MIL-HDBK-759B

5.2.1.18.2.2 Dynamic characteristics. The dynamic characteristics of simultaneously-operated hand cranks should be the same as those for specified single cranks in 5.2.1.3 and Figure 1. The gear ratio and dynamic characteristics of the cranks should be such as to allow precise placement of the follower (cross hairs) without overshooting or undershooting and successive corrective movements.

5.2.1.18.2.3 Dimensions. The dimensions for hand cranks should be as indicated in Figure 1.

5.2.1.18.3 Ball control. (Also known as track ball, ball tracker, joyball, and rolling ball.)

5.2.1.18.3.1 Application. A ball control suspended on low-friction bearings may be used for various control functions such as data pickoff on a display. The ball control cannot provide an automatic return to point of origin, hence if used in applications requiring automatic return to origin following an entry or readout, the interfacing system should provide this. Because the ball can be rotated without limit in any direction, it is well-suited for applications where there may be accumulative travel in a given direction. In any application which would allow the ball to drive the follower on the display off the edge of the display, indicators should be provided to advise the operator how to bring the follower back onto the display. Ball controls should be used only as position controls. A given movement of a ball makes a proportional movement of the follower on the display.

5.2.1.18.3.2 Dynamic characteristics. The ball control should be capable of rotation in any direction so as to generate any combination of x and y output values. When moved in either the x or y directions alone there should be no apparent cross-coupling (follower movement in the orthogonal direction). While manipulating the control, neither backlash nor cross-coupling should be apparent to the operator. Control ratios and dynamic features should be designed to meet the dual requirements of rapid gross positioning and smooth, precise fine positioning.

5.2.1.18.3.3 Dimensions and mounting. The diameter of the ball should be between 50 mm and 150 mm, depending upon the application and mode of operation to be used. The smaller diameters should be used only where space availability is tight and when there is no need for great precision. A diameter of approximately 100 mm is preferred for most applications. The preferred mounting for the ball control is in a horizontal surface such as a shelf or desk top, as shown in Figure 23. The exposed portion of the ball should form a 100° to 140° arc (120° preferred) relative to the horizontal surface.

MIL-HDBK-759B

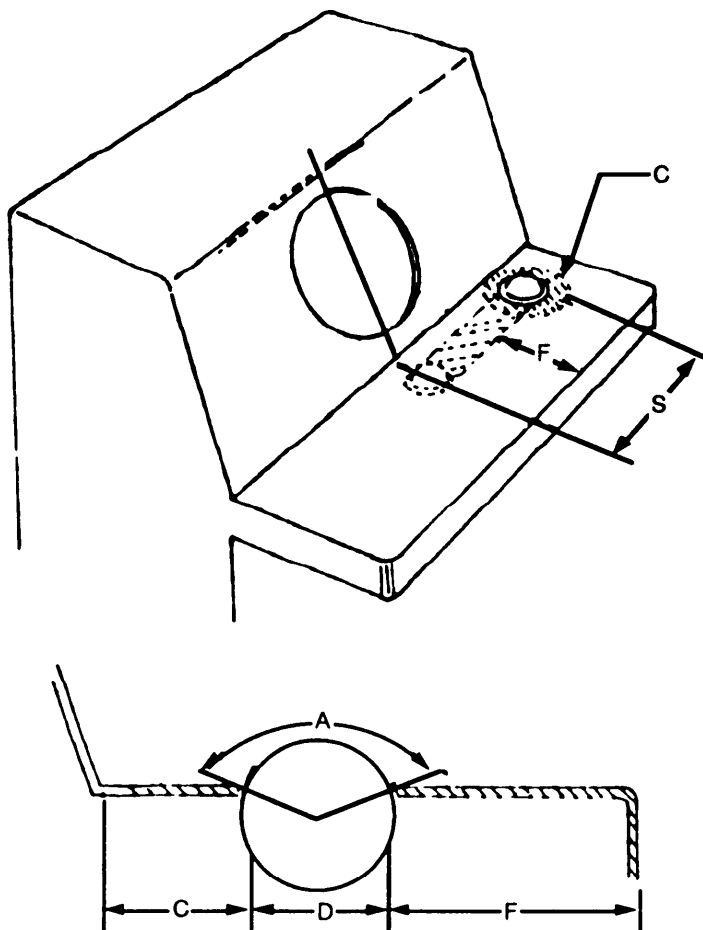

	DIMENSIONS		RESISTANCE		CLEARANCE		
	D DIAM	A SURFACE EXPOSURE	PRECISION REQUIRED	VIBRATION OR ACCEL CONDITIONS	S DISPLAY CL TO BALL CL	C AROUND BALL	F BALL TO SHELF FRONT
MINIMUM	50 mm	100°			0	50 mm	120 mm
MAXIMUM	150 mm	140°	1.0 N	1.7 N	320 mm		250 mm
PREFERRED	100 mm	120°	0.3 N				

FIGURE 23. Ball controls

MIL-HDBK-759B

5.2.1.18.4 Isometric joystick. (Also known as stiff stick, force stick, or pressure joystick.)

5.2.1.18.4.1 Application. The isometric joystick may be used for control of various display functions such as data pickoff from a CRT. In rate control applications which may allow the follower to travel beyond the edge of the display, indicators should be provided in order to advise the operator how to bring the follower back onto the display. Isometric joysticks are particularly appropriate for applications: (1) which require return to center after each entry or readout; (2) in which operator feedback is primarily visual from some system response rather than kinesthetic from the stick itself; and (3) where there is minimal delay and tight coupling between control input and system reaction. Isometric sticks should ordinarily not be used in any application where it would be necessary for the operator to maintain a constant force on the stick so as to generate a constant output over a sustained period of time.

5.2.1.18.4.2 Dynamic characteristics. The isometric stick should have minimal deflection in response to applied force, except that it may deflect perceptibly against a stop at full applied force. The x and y output should roughly approximate the magnitude of the applied force as perceived by the operator. Maximum force for full output with fingertip operation should not exceed 45N. For hand-grasped joysticks maximum force for full output should not exceed 120N.

5.2.1.18.4.3 Dimensions and mounting. Simple isometric joysticks (without integral switching) used in display systems should be of the finger-grasped shape and should be not more than 120 mm in shaft length and 15 mm in diameter. When integral switching is required, the hand-grasped shape should be used, with limiting dimensions of 110 mm and 180 mm for shaft length, and maximum grip diameter of 50 mm. The joystick preferably should be mounted in a shelf or desk surface as shown in Figure 24 so as to provide a minimum hand rest length of 120 mm from the shelf edge to the joystick shaft. In addition, clearances of 100 mm to the side and 50 mm to the rear should be provided to allow for hand movement.

5.2.1.18.5 Isotonic joystick. (Also known as displacement joystick.)

5.2.1.18.5.1 Application. The isotonic joystick may be used for various display functions such as data pickoff from a CRT and generation of freedrawn graphics. In rate control applications which allow the follower to travel beyond the edge of the display, indicators should be provided in order to advise the operator how to bring the follower back onto the display. Also, isotonic joysticks which are used for rate control should be spring-loaded for return to center when the hand is removed. Isotonic joysticks should not be used in connection with automatic sequencing of a hook or bug unless they are instrumented for null return or are zero-set to the instantaneous position of the stick at the time of sequencing. Upon termination of the automatic sequencing routine, joystick center should again be registered to scope center.

MIL-HDBK-759B

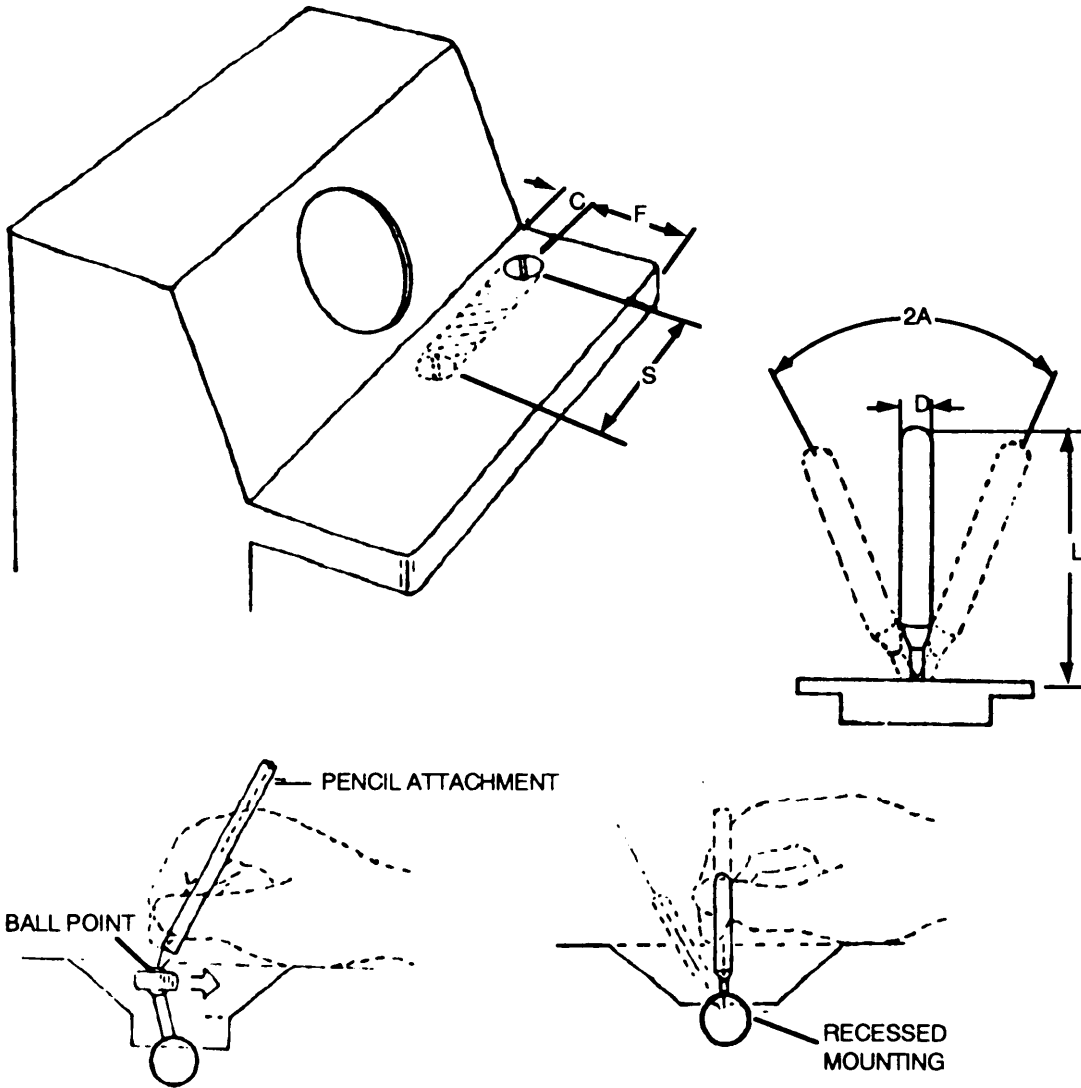

	DIMENSIONS		RESISTANCE	DISPLACEMENT A	CLEARANCE		
	D DIAM	L LENGTH			S DISPLAY CL TO STICK CL	C AROUND STICK	F STICK TO SHELF FRONT
MINIMUM	6.5 mm	75mm	3.3 N		0		120 mm
MAXIMUM	16 mm	150 mm	8.9 N	45°	400 mm	*	250 mm

*Maximum stock excursion plus 100 mm

FIGURE 24. Isotonic joysticks

MIL-HDBK-759B

5.2.1.18.5.2 Dynamic Characteristics. Maximum angular excursion of the isotonic joystick shaft from center position should not exceed 45°. Movement should be smooth in all directions, and rapid positioning of a follower on a display should be attainable without noticeable backlash, cross-coupling, or need for multiple corrective movements. Control ratios, friction, and inertia should be designed to meet the dual requirements of rapid gross positioning and precise fine positioning. Recessed mounting or pencil attachments may be used as indicated in Figure 24 to provide greater precision of control. One or more switches actuated by either thumb or finger pressure may be integrally mounted if compliant with 5.2.1.16.

5.2.1.18.5.3 Refresh rate. When used for generation of free-drawn graphics, the refresh rate for the follower on the CRT should be sufficiently high to ensure the appearance of a continuous track. Delay between contact movement and the confirming display response should be minimized and should not exceed 0.1 second.

5.2.1.18.5.4 Dimensions and mounting. Dimensions for isotonic joysticks used in display systems should be within the limits specified for isometric joysticks in 5.2.1.18.4 and mounting should conform to Figure 24, except that the clearance radius should be maximum stock excursion from center, plus 100 mm.

5.2.1.18.6 Grid and stylus devices. These provisions cover various techniques which utilize some means of establishing an x and y grid and stylus for designating specific points on that grid for control purposes (time-shared x and y potential grids and a voltage-sensitive stylus).

5.2.1.18.6.1 Application. Grid and stylus devices may be used for data pickoff from a CRT, for entry of points on a display, for generation of free-drawn graphics, and similar control applications. The grid may be on a transparent medium allowing stylus placement directly over corresponding points on the display or it may be displaced from the display in a convenient position for stylus manipulation. In either case a follower (bug, mark, or hook) should be presented on the display at the coordinate values selected by the stylus. Devices of this type should be used only for zero order control functions, where displacement of the stylus from the reference position causes a proportional displacement of the follower.

5.2.1.18.6.2 Dynamic characteristics. Movement of the stylus in any direction on the grid surface should result in smooth movement of the follower in the same direction. Discrete placement of the stylus at any point on the grid should cause the follower to appear at the corresponding coordinates and to remain steady in position so long as the stylus is not moved. Refresh rate for the follower should be sufficiently high to ensure the appearance of a continuous track whenever the stylus is used for generation of free-drawn graphics.

5.2.1.18.6.3 Dimensions and mounting. Transparent grids which are used as display overlays should conform to the size of the display. Grids which are displaced from the display should approximate the display size and should be mounted below the display in an orientation to preserve directional relationships to the maximum extent. (A vertical plane passing through the north/south axis on the grid should pass through or be parallel to the north/south axis on the display).

MIL-HDBK-759B

5.2.1.18.7 Free-mounting XY controller (mouse).

5.2.1.18.7.1 Application. This type of controller may be used on any flat surface to generate x and y coordinate values which control the position of the follower on the associated display. It may be used for data pickoff or for entry of coordinate values. It should be used for zero order control only (generation of x and y outputs by the controller results in proportional displacement of the follower). It should not be used for generation of free-drawn graphics.

5.2.1.18.7.2 Dynamic characteristics. The design of the controller and placement of the maneuvering surface should be such as to allow the operator to consistently orient the controller to within $\pm 10^\circ$ of the original reference of the controller. For example, when the operator grasps the controller in what he tactually assumes is the correct orientation and moves it rectilinearly along what he assumes to be straight up the y axis, then the direction of movement of the follower on the CRT should be between 350° and 100° . The controller should be easily movable in any direction without a change of hand grasp and should result in smooth movement of the follower in the same direction ($\pm 10^\circ$). The controller should be cordless and should be operable with either the left or right hand. A complete excursion of the controller from side to side of the maneuvering area should move the follower from side to side on the display regardless of scale setting or offset unless expanded movement is selected for an automatic sequencing mode of operation. In any application which would allow the controller to drive the follower off the edge of the display, indicators should be provided to advise the operator how to bring the follower back onto the display.

5.2.1.18.7.3 Dimensions and shape. The free-moving xy controller should have no sharp edges but should be shaped roughly as a rectangular solid, with limiting dimensions of 40-70 mm width (spanned by thumb to finger grasp), 70-120 mm length, and 25-40 mm thickness.

5.2.1.18.8 Light pen.

5.2.1.18.8.1 Application. A simple light pen may be used as a track-oriented readout device. That is, it may be positioned on the display screen so as to detect the presence of a computer-generated track by sensing its refresh pattern and the display system will then present a "hook" on the designated track. With suitable additional circuitry a follower can be made to track the movement of the light pen across the surface, thus allowing it to function as a two-axis controller capable of serving the same purposes served by the grid and stylus devices (see 5.2.1.18.6.1).

5.2.1.18.8.2 Dynamic characteristics. Dynamic characteristics of the light pen used as a two-axis controller should be as in 5.2.1.18.6.2.

MIL-HDBK-759B

5.2.1.18.8.3 Dimensions and mounting. The light pen should be between 7 mm and 20 mm in diameter and between 120 mm and 180 mm in length. A convenient clip should be provided at the lower right side of the CRT to hold the light pen when it is not in use.

5.2.1.18.9 Quickened and predictor types of controllers.

5.2.1.18.9.1 Applications. Complex tracking functions may require use of quickened or predictor approaches to control/display implementation. These approaches should be utilized only with the concurrence of the acquiring activity.

5.2.1.19 Miniature controls.

5.2.1.19.1 Use. Miniature controls may be used only when severe space limitations exist. Miniature controls should not be used when available space is adequate for standard-sized controls or when heavy gloves or mittens will be worn.

5.2.1.19.2 Dimensions, resistance, displacement, and separation. When design constraints dictate the use of miniature controls, the dimensions and separation of the controls should be the maximum permitted by the available space up to the maxima prescribed herein for standard-sized controls. Resistance and displacement of miniature controls should conform to the criteria specified for the standard size of that type of control.

5.2.1.19.3 Other criteria. Other design considerations (labeling, orientation) should conform to the criteria specified for the standard size of the control.

5.2.1.20 Touch-screen controls for displays.

5.2.1.20.1 Use. Touch-screen controls may be used to provide an overlaying control function to a data display device such as CRTs, dot matrix/segmented displays, electroluminescent displays, programmable indicators, or other display devices where direct visual reference access and optimum direct control access are desired.

5.2.1.20.2 Luminance transmission. When used, touch-screen overlays should transmit 50% or more of the display luminance.

5.2.1.20.3 Positive indication. A positive indication of touch-screen activation should be provided to acknowledge the system response to the control action.

5.2.1.20.4 Dimensions and separation. The dimensions and separation of responsive areas of the touch-screen should conform to S and B_w of Figure 12.

MIL-HDBK-759B

5.2.2 Displays.

5.2.2.1 General criteria. Designing any equipment component that people operate to obtain information about equipment status always has priority and requires a thorough knowledge of the kind, amount, and accuracy of information the operator will require. Almost all of the operator's decisions and actions depend on the information which is presented to him. All displays should conform to these general guidelines:

- a. Display only the information that is essential for adequate job performance.
- b. Display information only as accurately as the operator's decisions and control actions require.
- c. Present information in such a way that any failure or malfunction in the display or its circuitry will be obvious immediately.
- d. Present data in the most direct, simple, understandable, and usable form possible.
- e. Arrange displays so the operator can locate and identify them easily, without unnecessary searching.
- f. Group displays functionally or sequentially so the operator can use them more easily.
- g. Make sure that all displays are properly illuminated, coded, and labeled (including symbols) by their functions.
- h. The maximum viewing distance to displays located close to their associated controls should not exceed 635 mm. Otherwise, there is no maximum limit other than that imposed by legibility limitations, which should be compensated for by proper design.
- i. With the exception of CRT and collimated displays, the minimum viewing distance should never be less than 330 mm and preferably not less than 510 mm.
- j. The display should be illuminated with white light when dark adaptation is not essential. Red illumination should be used when dark adaptation is required (see 5.2.2.1.1 .1).
- k. A failure in the display should not cause associated equipment to fail.
- l. An alerting/warning display should provide the operator with a greater probability of detecting the triggering condition and also reduce the probability of a false alarm than his normal observation would provide in the absence of the display.

MIL-HDBK-759B

5.2.2.1.1 Display illumination. The full range of operational conditions should be taken into account in designing display illumination. A display which should be operable under conditions varying from night blackout conditions to full daylight should incorporate the necessary illumination features to allow proper use under all these widely varying conditions. A display which will always be used in a controlled lighting environment, such as a command control center, may need to satisfy illumination criteria only for the ambient conditions of that task environment. When complete dark adaptation is required, the illumination should be low-luminance (0.07-0.34 cd/m²) red light (greater than 620 nm); when only partial adaptation is required, low-luminance ambient illumination (preferably integral), adjustable as appropriate, should be used as appropriate for specific applications.

5.2.2.1.1.1 Night vision device compatibility. Where night vision device compatibility is required, display illumination color other than red may be used. The lighting should be continuously variable to the full OFF position. In the OFF position, no current should flow through the lamps.

5.2.2.1.2 Light distribution. Where multiple displays are grouped together, lighting should be balanced across the instrument panel such that the mean indicator luminances of any two instruments should not differ by more than 33% across the range of full ON to full OFF. Light distribution for integrally illuminated instruments should be sufficiently uniform such that the ratio of standard deviation of indicator element luminances to mean indicator luminances should not be more than 0.25, using eight or more equally-spaced test measurements.

5.2.2.1.3 Information criteria.

5.2.2.1.3.1 Content. The information displayed to an operator should be limited to that which is necessary for performing specific actions, monitoring a situation, or making decisions or assessments.

5.2.2.1.3.2 Precision. Information should be displayed only to the level of precision which is operationally meaningful and useful to the operator, except that scale designs should be based on logical numerical progressions. For example, in a system in which antenna position is known only to the nearest 7°, the best scale to use would be graduated in 5° intervals.

5.2.2.1.3.3 Format. Information should be presented to the operator in a directly usable form, whenever practical, so as to minimize the criteria for transposing, computing, interpolating, or converting of units.

5.2.2.1.3.4 Redundance. Redundancy of information appears in systems by presenting the same information in two or more different places, at two or more different times, or under two or more different encoding techniques. Redundancy may be constructively used to facilitate pattern recognition, enhance detectability, provide backup capability, speed up information retrieval, and increase reliability in information processing. Redundancy should be avoided, however, if it simply increases the volume of information which should be displayed and processed without obvious constructive purpose.

MIL-HDBK-759B

5.2.2.1.3.5 Combining operator/maintainer information. Operator and maintainer information should not be combined in a single display unless the information content and format are well-suited to, and time compatible for, both users.

5.2.2.1.3.6 Display failure indication. Displays should be so designed that failure of the display itself or of the associated display circuitry will be readily apparent to the operator by a suitable technique such as one or more of the following:

- a. the display illumination is extinguished;
- b. the display sweep stops scanning; or
- c. a failure indicator is energized.

5.2.2.1.3.7 Display circuit failure. Failure of the display circuit should not cause a failure in the equipment associated with the display.

5.2.2.1.3.8 Unrelated markings. Trademarks and company names or other similar markings not related to panel function should not be displayed on the panel face. If any unrelated markings are displayed at all, they should be displayed with reduced character size and diminished contrast so as to reduce their conspicuity in comparison with the other markings.

5.2.2.1.3.9 Advisory and alerting. Displays such as multi-function displays, CRT displays, head-up displays, collimated displays, and other visual display devices displaying simultaneous and integrated information should advise or alert operating personnel to information that becomes critical within the display.

5.2.2.1.3.10 NBC contamination. As applicable, display characteristics (clarity, legibility) should be compatible with viewing while wearing an NBC protective mask. Displays or indicators that show the presence of NBC agents should also show when such agent concentrations decrease to safe levels.

5.2.2.1.4 Display location and arrangement. Display location and arrangement should be in accordance with the factors identified in 5.2.3, and the following additional criteria specific to displays. Limits on display location are also defined in Figures 25 and 26.

5.2.2.1.4.1 Accuracy. Displays should be located and designed so that they may be read to the degree of accuracy required by operating and serving personnel when they occupy expected nominal working positions. Consideration should be given to viewing distance, viewing angle, illumination, and possible intervening obstacles.

MIL-HDBK-759B

5.2.2.1.4.2 Access. Visual displays should be visually accessible without resorting to use of ladders, flashlights or other special equipment in order to read the display.

5.2.2.1.4.3 Orientation. Reading errors caused by parallax should be minimized by positioning display faces perpendicular to the operator's normal line of sight (see Figure 25), or not less than 45° from the normal line of sight.

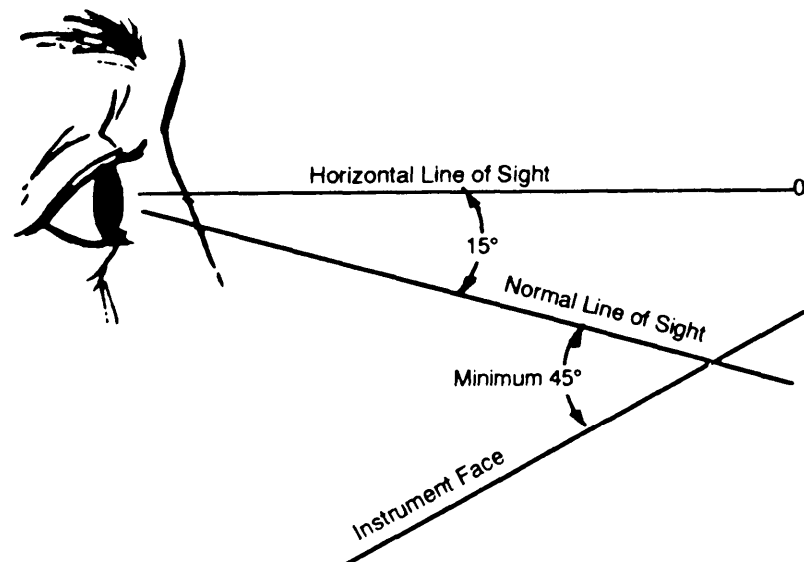

FIGURE 25. Lines of sight

5.2.2.1.4.4 Reflection. Displays should be constructed, arranged, positioned, shielded, and/or cover glass treated to minimize loss of information transfer caused by reflections (ambient light, reflection of the operator or other objects within the viewing envelope). Reflection of instrument faces in windshields or other critical viewing windows should be avoided. If necessary, special dispbdillumination filterin9 techniques should be used to ensure that system performance will not be degraded.

5.2.2.1.4.5 Vibration. Vibration of visual displays should not degrade user performance below the level required for mission accomplishment.

5.2.2.1.4.6 Viewing Distance. Display location relative to the operator depends on several factors, such as display detail, size, illumination vs nominal viewing distance, and whether the operator should have manual contact with the display. Displays should not be located so far from the operator that displayed detail cannot be remgnized or read, nor should the display be placed so close to the operator that visual accommodation becomes difficult and tiring. The criteria listed below should apply:

MIL-HDBK-759B

- a. Viewing distance from the eye reference point of displays located close to associated controls should not exceed 635 mm.
- b. Minimum viewing distance should be not less than 330 mm and preferably not less than 405 mm.

5.2.2.1.4.7 Aircrew station signals. Signals for aircrew stations should be in accordance with MIL-STD-411. Human engineering design for other members of the crew who occupy positions in the air vehicle other than on the flight deck should be in accordance with the criteria in this handbook.

5.2.2.1.5 Coding.

5.2.2.1.5.1 Objectives. Coding techniques should be used to facilitate:

- a. discrimination between individual displays,
- b. identification of functionally related displays,
- c. indication of relationship between displays,
- d. identification of critical information within a display, and
- e. general ease with which display features can be discriminated within a single display.

5.2.2.1.5.2 Techniques. Displays may be coded by color, size, location, shape, or flash coding, as applicable.

5.2.2.1.5.3 Standardization. Display coding within a system should be uniform. Previously established coding standards should be followed, and any variations from these, and/or newly-proposed codes should be established by agreement with the acquiring activity.

MIL-HDBK-759B

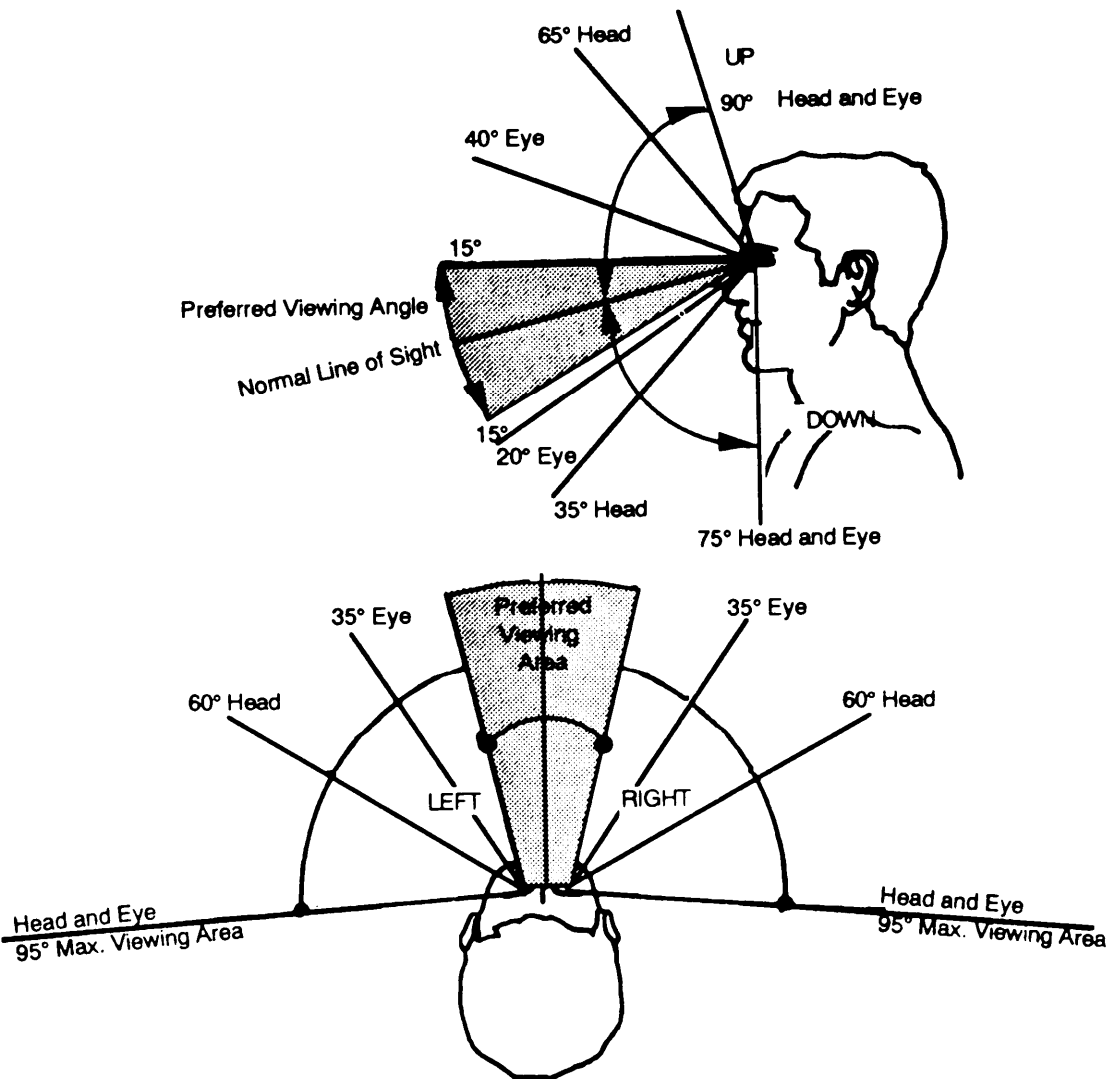

	PREFERRED	MAXIMUM*		
		EYE ROTATION ONLY	HEAD ROTATION	HEAD AND EYE ROTATION
UP	15°	40°	65°	90°
DOWN	15°	20°	35°	75°
RIGHT	15°	35°	60°	95°
LEFT	15°	35°	60°	95°

*Display area on the console defined by the angles measured from the normal line of sight.

FIGURE 26. Visual field

MIL-HDBK-759B

5.2.2.2 Transilluminated displays.

5.2.2.2.1 General. Transilluminated displays may be used to indicate system, equipment, and/or control condition. These general types should be considered:

- a. Single- and multiple-legend lights, which present information in the form of meaningful words, numbers, symbols, and abbreviations.
- b. Simple indicator lights, such as pilot lights, bull's-eye or jewel lights, and exterior signal lights.
- c. Transilluminated panel assemblies, which present qualitative status or system readiness information.

5.2.2.2.1.1 Application. Transilluminated displays should be used to display qualitative information to the operator when requiring either an immediate reaction by the operator, or to draw attention to an important system status. Such indicators may also be used occasionally for maintenance and adjustment functions.

5.2.2.2.1.2 Equipment response. Generally, equipment state rather than control position or condition should be displayed, considering the following:

- a. equipment state should always be continually displayed,
- b. control actuation should be transiently displayed, and
- c. control setting should be continuously displayed if it can be at variance with equipment state. An in-transit condition should remain ON until the system state is consistent with the control state (except for in-transit durations shorter than the operator's response time).

5.2.2.2.1.3 Information. Because of the distracting characteristics of light-generated displays, they should be used sparingly and should display only that information necessary for effective system operation.

5.2.2.2.1.4 Master warning, caution, and advisory lights. Master warning, caution, and/or advisory lights should be set apart from the lights which show the status of the subsystem components when used to indicate the condition of an entire subsystem, except as required under 5.2.2.2.1.6.

5.2.2.2.1.5 Location of transilluminated displays.

- a. When an indicator is associated with a control, the indicator light should be so located as to be immediately and unambiguously associated with the control and visible to the operator during control operation (except when the light is in an integral part of special control handles such as aircraft flight controls).

MIL-HDBK-759B

- b. Critical function indicators (safe--related master warning lights) should be located within 15° of the operator's normal line of sight (see Figure 26), except as indicated in (a) above.

5.2.2.2.1.6 Maintenance display. Indicator lights used solely for maintenance and adjustment should be covered or made less conspicuous during normal operation (they are not illuminated except when actual maintenance is being performed). Covered elements should be easily accessible when required.

5.2.2 .2.1.7 Display luminance and visibility.

5.2.2.2.1.7.1 Luminance. The luminance (brightness) of transilluminated displays should be compatible with the expected range of ambient illuminances associated with mission operation and/or servicing and maintenance of the system and equipment. The following factors should be considered in determining luminance levels:

- a. Within-display contrast, such as contrast between light ON vs OFF modes; two-level contrast if display requires a dormant luminance to read an identifying label, plus an active luminance increase to indicate functioning mode.
- b. Display/surround contrast, such as contrast between the illuminated indicator and its immediate panel surface, in which case effects of ambient reflection on either the display or surround should be compensated for by such means as increased display luminance, surround surface modification, or use of filters or shields.
- c. Operator visual-adaptation criteria, such as display luminance, should be compatible with the operator's criteria to detect low-level signals or targets in the external visual environment, and/or perceive faint signals on a CRT or read red-lighted instruments provided for night operation.
- d. Conspicuity and attention-demand criteria, such as luminances should provide the required alerting to ensure that the operator will not miss a critical warning, caution, or advisory message.
- e. Distraction, such as luminance levels, should not dazzle or otherwise distract the operator in a manner that could be detrimental to safe, efficient system operation.

5.2.2.2.1.7.2 Luminance level. Luminance of the illuminated indicator should be at least 10% greater than the immediate mounting surface. When a two-level indicator is used, the difference between the dormant and illuminated brightnesses should be approximately 1:2, considering always the factors noted in 5.2.2.2.1.7.1. Where glare should be reduced, the luminance of transilluminated displays should not exceed 300% of the surrounding luminance.

MIL-HDBK-759B

5.2.2.2.1.7.3 Luminance control. When displays will be used under varied ambient illuminance, a dimming control should be provided. The range of control should permit the displays to be legible under all expected ambient illuminance. The control should be capable of providing multiple-step or continuously-variable illumination. Dimming from “full-ON” to “full-OFF” may be provided in certain non-critical operations.. However, this option should not be available if inadvertent failure to fully-illuminate indicator(s) could lead to operator failures such as overlooking a critical step.

5.2.2.2.1.8 Color coding. With the exception of aircrew station signals which should conform to MIL-STD-411, and training equipment which should conform to MIL-T-23991, transilluminated displays should conform to the following color coding scheme, in accordance with Type I - Aviation colors of MIL-C-25050.

- a. RED should be used to alert an operator that the system or any portion of the system is inoperative, or that a successful mission is not possible until appropriate corrective or override action is taken. Examples of indicators which should be coded RED are those which display such information as “no-go,” “error,” “failure,” or “malfunction.”
- b. FLASHING RED should be used only to denote emergency conditions which require operator action to be taken without undue delay, or to avert impending personnel injury, equipment damage, or both.
- c. YELLOW should be used to advise an operator that a condition exists which is marginal. YELLOW should also be used to alert the operator to situations where caution, recheck, or unexpected delay is necessary.
- d. GREEN should be used to indicate that the monitored equipment is in tolerance or a condition is satisfactory and that it is all right to proceed (“go-ahead,” “in-tolerance,” “ready,” “function activated,” “power on”).
- e. WHITE should be used to indicate system conditions that do not have “right” or “wrong” implications, such as alternative functions (Missile No. 1 selected for launch) or transitory conditions (action or test in progress, function available), provided such indication does not imply success or failure of operations.
- f. BLUE may be used for an advisory light, but preferential use of BLUE should be avoided.

5.2.2.2.1.9 Flashing lights. The use of flashing lights should be minimized. Flashing lights may be used only when it is necessary to call the operator’s attention to some condition requiring immediate action. The flash rate should be 3 to 5 Hz with an approximately 50% duty cycle. Flashing lights which could be simultaneously active should have synchronized flashes. If the indicator is energized and the flasher device fails, the light should illuminate and burn steadily.

MIL-HDBK-759B

5.2.2.2.2 Legend lights.

5.2.2.2.2.1 Application. Transilluminated displays containing legends should be used in preference to simple indicator lights except in certain applications such as power pilot lights, and/or vehicular and other external signaling lights. The number of legend lights should be kept to a minimum, as needed to provide required information feedback. A legend light should be used to provide qualitative information; it should not give a command. If a command should be given, the legend should clearly and unambiguously indicate that this is the case.

5.2.2.2.2.2 Design. The legend face should be essentially in the plane of the panel which houses it (not recessed) and should have large enough front areas to accommodate the anticipated legends without requiring unreasonable abbreviation. The possibility of losing or interchanging legends should be minimized by such techniques as captive legends. There should be a border around each legend not less than the width of the letter "H" of the selected font.

5.2.2.2.2.3 Visibility and legibility. Legends should be visible to the operator whether or not the indicator is energized, except in warning and caution indicators, and flight crew stations. See 5.5 for size and other characteristics of lettering used for legends.

5.2.2.2.2.4 Color coding. Legend lights should be color coded in conformance with 5.2.2.2.1.8. Legend lights required to denote personnel or equipment disaster (FLASHING RED), caution or impending danger (YELLOW), and master summation go (GREEN) or no-go (RED), should be discriminably larger, and preferably brighter, than all other legend lights (see Table 19).

5.2.2.2.2.5 Size coding. Display size may be used sparingly as a coding device, such as legend lights that denote danger to personnel or equipment failure, may be discriminably larger than other indicators. Typically these should also be color coded and where appropriate, brighter than other indicators.

5.2.2.2.2.6 Illumination. A legend light should illuminate immediately upon the occurrence of the event described by its legend; it should go out when that event terminates. There should not be light leakage around the illuminated light.

5.2.2.2.2.7 Malfunctions. Legend-light indications for isolating malfunctions should be provided only down to the point dictated by the system maintenance philosophy. They should operate in a fail-safe fashion. Failure of a legend light or its indicator circuit should not influence or cause failure of its monitored circuits and equipment.

MIL-HDBK-759B

TABLE 19. Coding of simple indicator lights

SIZE/TYPE	COLOR		
	RED	YELLOW	GREEN
13 mm DIAMETER or SMALLER/STEADY	Malfunction; action stopped, failure; stop action.	Delay; check; recheck	Go ahead; in tolerance; acceptable, ready.
25 mm DIAMETER or LARGER/STEADY	Master summation (system or subsystem).	Extreme caution (impending danger).	Master summation (system or subsystem).
25 mm DIAMETER or LARGER/FLASHING (3 to 5 Hz)	Emergency condition (impending personnel or equipment disaster).		Functional or physical position; action in progress.

MIL-HDBK-759B

5.2.2.2.2.8 Visual contrast. Optimum visual contrast should be provided between the legend lettering and its background. The face of the light should not have trademarks, company names or other similar markings unrelated to the information displayed.

5.2.2.2.2.9 Redundancy. Lamps should have redundant filaments or dual bulbs; that is, when one filament or bulb fails, the second remains illuminated. The decreased intensity of the light indicates the need for lamp replacement.

5.2.2.2.2.10 Multi-function legends. Indicators designed to provide alternately-presented legends should present only one legend at a time. (The legend not in use should not be visible.) If the indicator device uses "stacked" legends, it should be designed so that (1) when the rear legend is energized, it should not be obscured by the front legend(s); (2) rear legend plates are so positioned as to minimize parallax; and (3) rear legends have approximately equal brightness to front legends, and the contrast between rear legends and background is equal to that of the front legend and its background.

5.2.2.2.3 Simple indicator, signal, and identification lights.

5.2.2.2.3.1 Application. Simple, non-legend light displays may be used when design considerations make legend light displays impractical, such as the following:

- a. Small pilot lights preclude legend or symbol imprint on display surface. (Application primarily for Power ON-OFF indication.)
- b. Small equipment indicator, such as light to indicate radio is in AM vs FM mode.
- c. Vehicular panel indicators, such as "high beam" headlight mode, left/right "turn-signal indication."
- d. External vehicle identification/mode lights, such as rear caution/stop/backup/turn lights, vehicle perimeter warning lights, and blackout aircraft position lights, navigation lights, anti-collision lights.
- e. Ground-based beacons, airport runway, taxiway, obstacle warning and roadway signal lights.
- f. Marinecraft position, navigation and signaling lights.

5.2.2.2.3.2 International conventions and standards. International conventions and standards for aircraft, highway vehicles, and marinecraft should be followed in design, location, and luminance characteristics of all military systems utilizing public roadways, airways, or navigable streams, rivers and sea-lanes.

5.2.2.2.3.3 Location and spacing. Simple light displays used on operator control panels should be located and spaced to ensure that they are visible (not obscured by an intervening control, operator's hand, or at an angle that causes the indicator bezel

MIL-HDBK-759B

to diminish the effectiveness of the light). They should also be far enough apart so that lamp replacement is convenient.

5.2.2.2.3.4 Brightness. Simple light displays used on operator control panels should be sufficiently bright for the operator to easily differentiate between an ON and OFF condition. The indicator also should be designed and/or otherwise positioned or shielded so that bright ambient light will not cause the indicator to appear lighted when it is not, and/or so that the lighted indicator will not reflect on other critical viewing surfaces and thus diminish viewing effectiveness of a display or window. Light indicators should not be so bright as to create “dazzle” and/or destroy operator dark adaptation where required.

5.2.2.2.3.5 Coding. Size coding of simple light displays on operator control panels should conform to criteria presented in Table 19. Shape coding may be used to aid the operator in quickly identifying a function, and/or to provide additional information, such as “arrow-shaped,” or vehicle turn indicator lights identify the direction of turn (left or right). Color coding of such displays should conform to information in 5.2.2.2.2.4 and Table 19.

5.2.2.2.3.6 Critical functions. For critical functions, the indicator should be located within 15° of the normal line of sight. Warning lights should be integral with, or adjacent to, the lever, switch, or other control device by which the operator is to take action.

5.2.2.2.3.7 Caution, warning, and malfunction indicators. Master caution, master warning, and summing lights used to indicate the condition of the entire subsystem should be set apart from, and larger than, the lights which show the status of the subsystem components. A malfunction should be indicated by a malfunction indication, not by the mere absence of an operating-condition signal.

5.2.2.2.4 Transilluminated panel assemblies. Transilluminated (integrally-lighted) panel assemblies should be considered for the following:

- a. To provide illuminated labels for a control panel.
- b. To provide a light source for illuminating transilluminated control knobs.
- c. To provide illuminated association markings on a control panel, such as connecting lines between controls, outlines around a functionally related group of controls and/or displays.

MIL-HDBK-759B

- d. To create a “pictorialized” representation of a system process, communication network, or other information or component organization.

5.2.2.2.4.1 Integrally-lighted subpanels. Integrally-lighted subpanels should be designed so that all panel markings are equally visible throughout the range of panel light level adjustment; and brightness variation among separate subpanels on the same lighting circuit should not exceed 1:7.

5.2.2.2.4.2 Large, single-pictorial, graphic panels. Large, single-pictorial graphic panels used to display items such as system processing or communications networks should comply with criteria for visibility, legibility, color, and illumination as specified herein.

5.2.2.2.4.3 Re-lamping. When incandescent lamps are used as the source for integral lighting of panel assemblies, lamps should be readily accessible without removing the panel(s). There should be a sufficient number of lamps provided so that failure of one lamp will not cause the display to be unreadable.

5.2.2.2.4.4 Brightness. Brightness of illuminated panel markings and/or transilluminated controls should be compatible with the ambient environment and/or the operating conditions (dark adaptation criteria). Brightness control (dimming) by the operator should be provided where applicable to maintain appropriate visibility and/or operator dark adaptation level.

5.2.2.3 Scalar Indicators.

5.2.2.3.1 General.

5.2.2.3.1.1 Applications. Scalar indicators should be used in preference to digital readouts when the data displayed are of qualitative as well as quantitative value (when trends, direction of movement, more-than/less-than relationships are of value as well as the specific numeral value), or of qualitative value only. Scalar indicators should not be used when the primary purpose is readout of precise quantitative information. (see Table 20.)

5.2.2.3.1.2 Preferred. The preferred type of scalar indicator for most applications has a moving pointer and a fixed scale. (The scale may be circular, curved (arc), horizontal straight, or vertical straight.) With a moving-pointer, fixed-scale indicator, both the scale progression and control movement are compatible with operator expectancies. Therefore, this type of scale can be used effectively wherever a scalar indicator is required. The other major type of scalar indicator has a fixed pointer and a moving pointer. Because there is always compromise to one or another human engineering principle in use of this design, its use should be limited to the following applications: (a) where multiple scales can be lined up and read in a row or column (with the readout values always appearing in the same position--preferably in the center of window openings) and/or (b) where speed and accuracy of setting is not critical.

MIL-HDBK-759B

TABLE 20. Application of various types of mechanical displays

USE	SCALAR INDICATORS			PICTORIAL INSTRUMENTS	PRINTERS	FLAGS
	MOVING-POINTER	MOVING-SCALE	MECHANICAL COUNTERS			
QUANTITATIVE INFORMATION	GOOD Difficult to read while pointer is in motion.	FAIR Difficult to read while scale is in motion.	GOOD Minimum time and error for exact numerical value, but difficult to read when moving.	FAIR Direction of motion/scale relations sometimes conflict, causing ambiguity in interpretation.	GOOD Minimum time and error for exact numerical value.	N/A
QUALITATIVE INFORMATION	GOOD Location of pointer easy. Numbers and scale need not be read. Position change easily detected.	POOR Difficult to judge direction and magnitude of deviation without reading numbers and scale.	POOR Numbers must be read. Position changes not easily detected.	GOOD Real world situation more quickly assimilated.	POOR Numbers must be read. Position changes not easily detected.	GOOD Easily detected. Economical of space.
SETTING	GOOD Simple and direct relation of motion of pointer to motion of setting knob. Position change aids monitoring.	FAIR Relation to motion of setting knob may be ambiguous. No pointer position change to aid monitoring. Not readable during rapid setting.	GOOD Most accurate monitoring of numerical setting. Relation to motion of setting knob less direct than for moving-pointer. Not readable during rapid setting.	GOOD General direct control-display relationship easy to observe.	N/A	N/A
TRACKING	GOOD Pointer position readily controlled and monitored. Simplest relation to manual control motion.	FAIR No position changes to aid monitoring. Relation to control motion somewhat ambiguous.	POOR No gross position changes to aid monitoring.	GOOD Same as above.	N/A	N/A
DIFFERENCE ESTIMATION	GOOD Easy to calculate positively or negatively by scanning scale.	FAIR Subject to reversal errors.	POOR Requires mental calculation.	GOOD Easy to calculate either quantitatively or qualitatively by visual inspection.	FAIR Can predict possible future pattern of pen trace.	N/A
PERMANENT RECORD	N/A	N/A	N/A	N/A	GOOD Provides hard copy.	N/A
GENERAL	Requires largest exposed and illuminated area on panel. Scale length limited unless multiple pointers used. Some panel space. Only small section of scale need be exposed and illuminated. Use of tape allows long scale. Most economical of space and illumination. Scale length limited only by numbers of counter drums.					

MIL-HDBK-759B

5.2.2.3.1.3 Scale linearity. Scales should be graduated linearly even if the function being controlled is non-linear. If the non-linearity of the function causes too much scale compression making readout or adjustment difficult, another type of device such as a moving-tape indicator would be preferred over use of a non-linear scale.

5.2.2.3.1.4 Scale marking and numbering.

5.2.2.3.1.4.1 Graduation markings. Scale graduations should be in increments of 1, 2, or 5 units or decimal multiples thereof (except as noted in 5.2.2.3.1.4.2). No more than three sizes of marks should be used on any scale. The scales which require three sizes of marks include those which have numbered values in multiples of 10 but are graduated in 5° and 10° intervals. The number of graduation marks between numbered marks (not to exceed nine) are presented in Table 21, and illustrations of scales graduated in various ways are provided in Figure 27.

5.2.2.3.1.4.2 Scale numerals. Except for measurements that are normally expressed in decimal fractions, whole numbers should be used for major graduation marks. Intermediate marks should ordinarily not be numbered. On fixed scales, numerals should be vertically oriented, and on rotating scales numerals should be radially oriented and positioned so as to be upright when read against the pointer. Bearing dials should have numerals (and major graduation marks) at either 10° or 30° as shown in Figure 28.

5.2.2.3.1.4.3 Scale length. Scales should start and end on a major graduation mark even if this puts either or both ends beyond the usable range of the scale. For example, if the maximum voltage which can be read on an instrument is 23 volts, the scale should go at least to 25 volts where there could be a major graduation mark.

5.2.2.3.1.4.4 Starting point. Display scales should start at zero, except where this would be inappropriate for the function involved.

5.2.2.3.1.5 Pointers.

5.2.2.3.1.5.1 General. For best legibility, indicators with scales should have pointers that are relatively wide at the pivot, tapering gradually to a fine tip, arrowhead, or teardrop that is the same width as the smallest graduation mark.

MIL-HDBK-759B

TABLE 21. Scale of markings

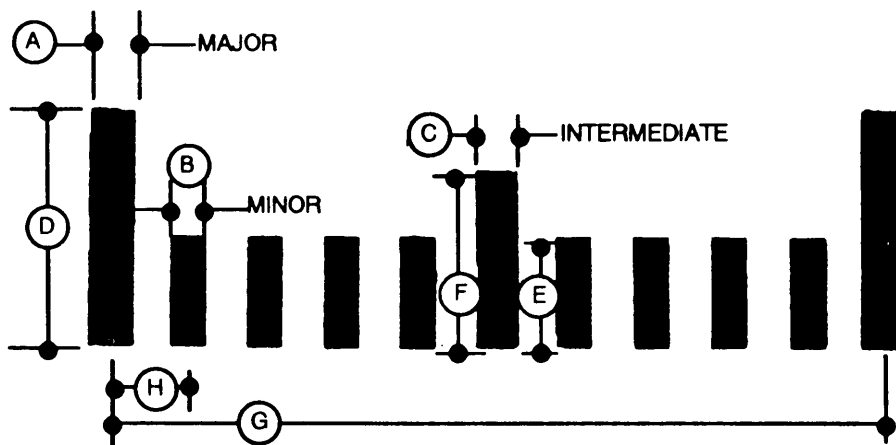

Dimension	Viewing Distance (in mm)		
	710	910	1525
A (Major index width)	0.89	1.14	1.90
B (Minor index width)	0.64	0.81	1.37
C (Intermediate index width)	0.76	0.99	1.63
D (Major index height)	5.59	7.19	12.00
E (Minor index height)	2.54	3.28	5.44
F (Intermediate index height)	4.06	5.23	8.71
G (Major index separation between midpoints)	17.80	22.90	38.00
H (Minor index separation between midpoints)	1.78	2.29	3.81

Minimum scale dimensions for low illumination (1-3.4 cd/m²)

MIL-HDBK-759B

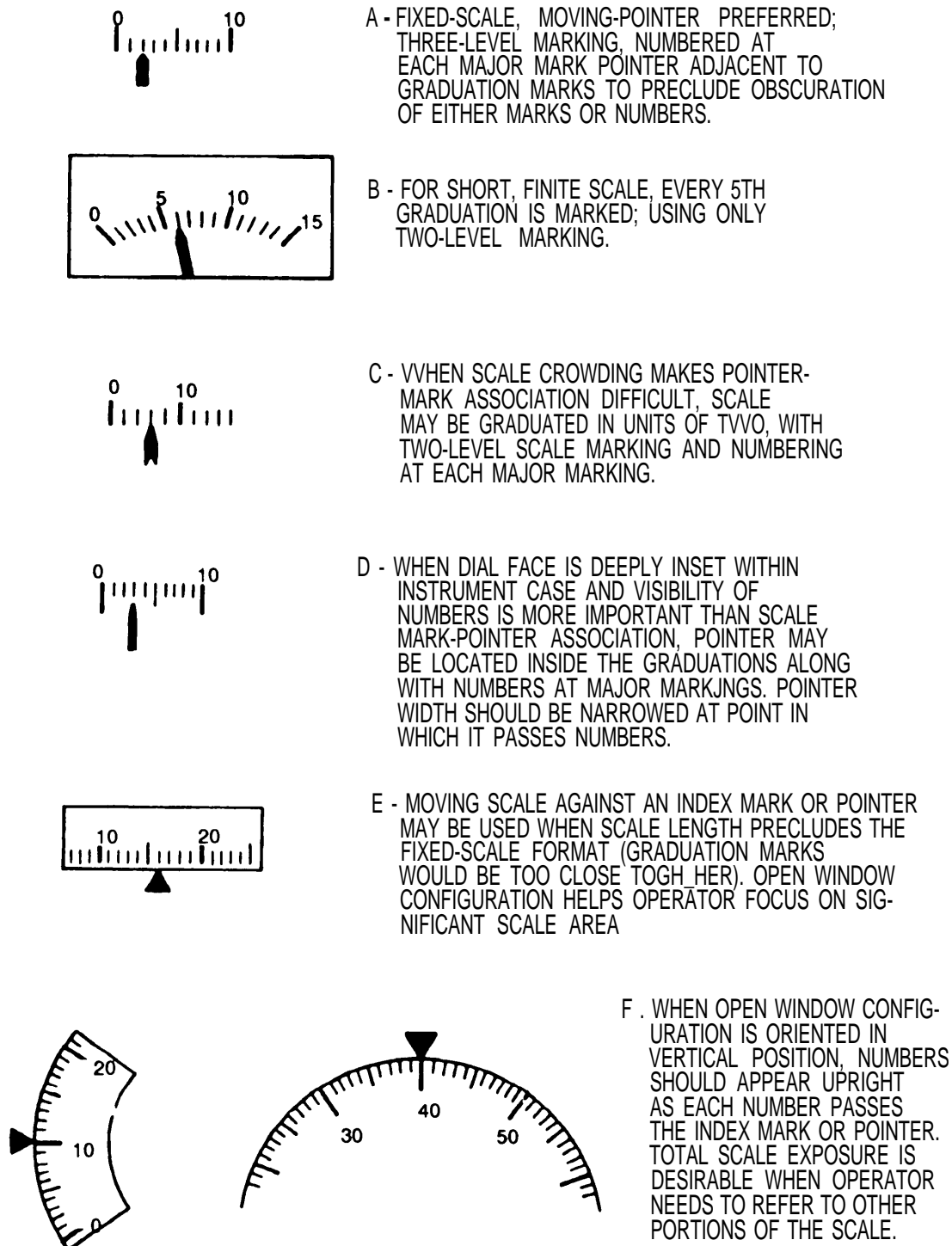
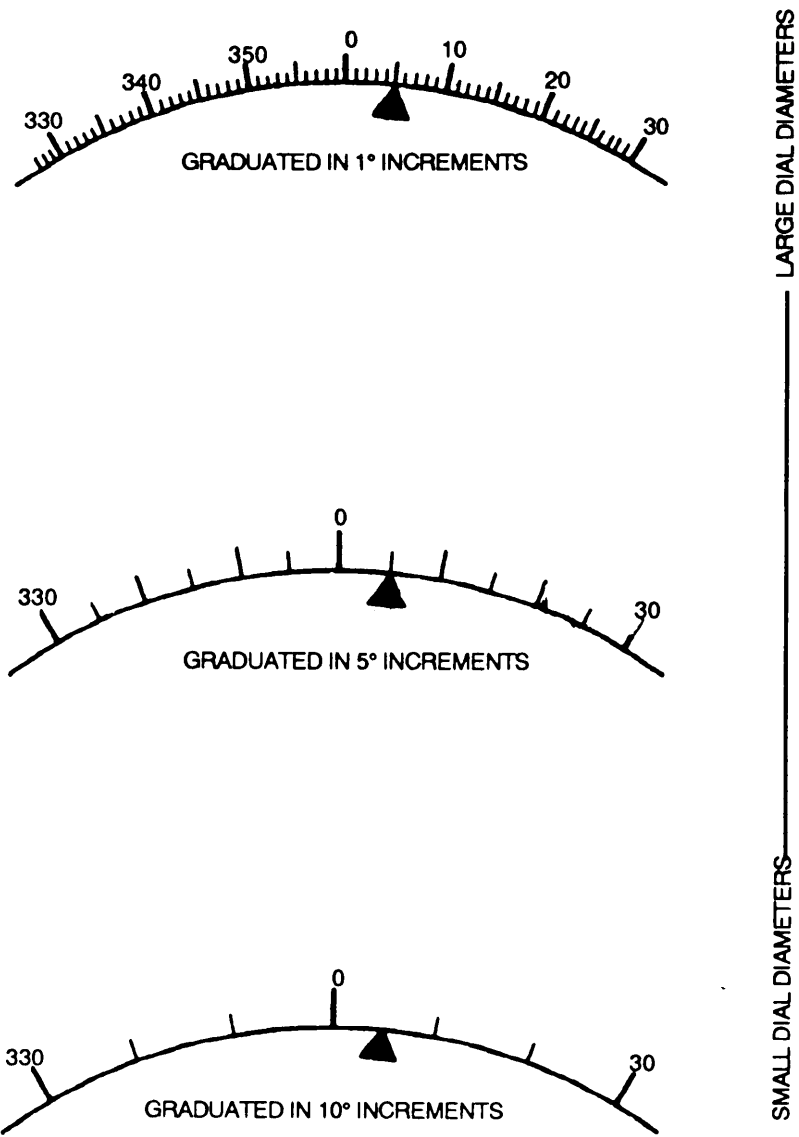

FIGURE 27. Scale graduation, pointer position and scale numbering alternatives

MIL-HDBK-759B



*NOTE: THE ABOVE GENERAL SCALE MARKING CONCEPTS ALSO APPLY TO DISPLAYS IN WHICH MEASURE IS IN MILS.

FIGURE 28. Fixed-scale azimuth dials

MIL-HDBK-759B

5.2.2.3.1.5.6 Luminance contrast. Luminance contrast of at least 75% should be provided between the scale face and the markings and pointer.

5.2.2.3.1.5.7 Color. Pointer color from the tip to the center of the dial should be the same as the color of the marks. The tail of the pointer should be the same color as the dial face unless the tail is used as an indicator itself or unless the pointer is used for horizontal alignment.

5.2.2.3.1.5.8 Pointers per shaft. There should not be more than two pointers on a single shaft.

5.2.2.3.1.5.9 Reciprocal pointers. With reciprocal (double-ended) pointers, it should be easy to distinguish the end that indicates the reading.

5.2.2.3.1.5.10 Edgewise indicators. In edgewise indicators, such as rectangular meters with straight scales, only the tip of the pointer may be visible. If so, it should be distinctive and obvious: a flag, spade, or target pointer.

5.2.2.3.1.5.11 Dial faces. If the display is used for making a setting, such as tuning in a desired wavelength, it is usually advisable to cover the unused portion of the dial face. The open window should be large enough to show at least one numbered graduation on each side of any setting. If the display is one used in tracking, such as a heading indicator, the whole dial face should be exposed.

5.2.2.3.1.5.12 Coding. When certain operating conditions (such as normal operating temperature or dangerous pressure level) always fall within a limited range of the total scale, these ranges should be made readily identifiable by means of pattern, color, or shape coding applied to the face of the instrument. Use of red color coding should be limited to critical situations. Operating zones may be shape coded when the indicator should be viewed in very low-light-level work environments (0.07-0.7 cd/m²) or where the illuminant color will cause difficulty in discrimination of colors (see Figure 29).

5.2.2.3.2 Moving-pointer, fixed-scale indicators.

5.2.2.3.2.1 Numerical progression. Numbered scales show increase clockwise, from left to right, or from bottom to top, depending on the scale layout (circumferential, or linear in horizontal or vertical axis).

5.2.2.3.2.2 Orientation of numerals. Numbers on fixed scales should appear vertical (upright) to the observer.

MIL-HDBK-759B

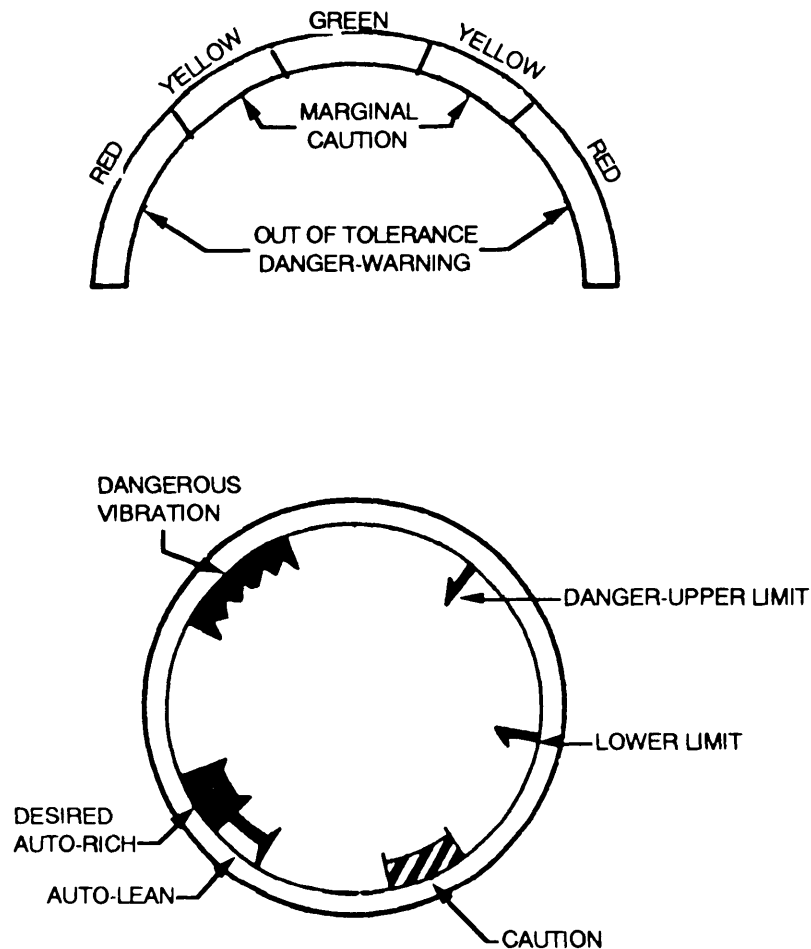

FIGURE 29. Shape/color coding operating ranges

5.2.2.3.2.3 Circular scales.

5.2.2.3.2.3.1 Scale reading and pointer movement. To display values ranging from negative through zero to positive, locate the zero point at the 9 or 12 o'clock position. The magnitude of positive values should increase when the pointer moves clockwise (to the right), and the magnitude of negative values should increase when the pointer moves counterclockwise (to the left).

5.2.2.3.2.3.2 Zero position and pointer movement. The position of the zero value on a numbered scale and the relative pointer movement should conform to criteria in Figure 30.

MIL-HDBK-7S9B

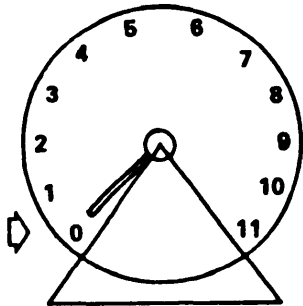

WHEN A DIAL SCALE IS OF FINITE LENGTH, IT SHOULD BE NUMBERED SO THAT VALUE INCREASE IS CLOCKWISE. THE ZERO STARTING POINT SHOULD BE APPROXIMATELY AT THE 7 O'CLOCK POSITION. THERE SHOULD BE AN OBVIOUS "BREAK" BETWEEN THE TWO ENDS OF THE SCALE OF AT LEAST 10° OF ARC.

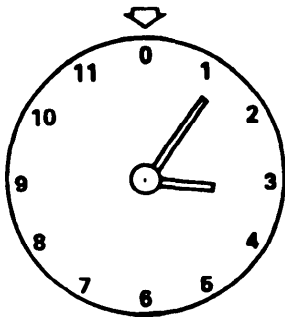

WHEN MULTIREVOLUTION POINTER MOVEMENT IS INVOLVED, THE ZERO REFERENCE SHOULD BE AT THE TOP OF THE DIAL AND THERE SHOULD BE NO BREAK BETWEEN SCALE ENDS. NO MORE THAN TWO POINTERS SHOULD BE USED EXCEPT FOR SPECIAL CASES, SUCH AS A CLOCK (WITH SECOND HAND).

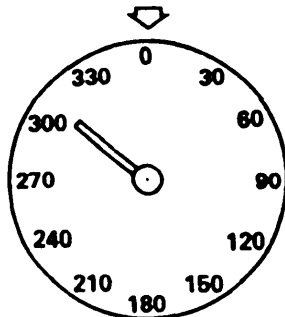

AZIMUTH DIAL SCALES SHOULD BE LAID OUT WITH THE ZERO (OR NORTH) REFERENCE AT THE TOP OF THE DIAL AND SCALE VALUES SHOULD INCREASE CLOCKWISE. AT LEAST EVERY 30° REFERENCE SHOULD BE NUMBERED.

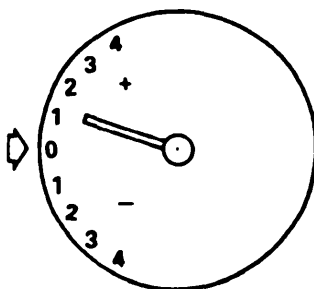

POSITIVE/NEGATIVE DIAL FORMATS SHOULD BE LAID OUT WITH THE ZERO (OR "NULL" POSITION) LOCATED AT THE 9 OR 12-O'CLOCK POSITIONS. SCALE VALUES SHOULD INCREASE RIGHT OR LEFT, OR UP OR DOWN AS APPROPRIATE TO PROVIDE POSITIVE/NEGATIVE POINTER MOVEMENT RELATIONSHIPS.

FIGURE 30. Zero position and pointer movement for circular dial displays

MIL-HDBK-759B

5.2.2.3.2.3.3 Scale break. There should be an obvious break of at least 10° of arc between the two ends of the scale, except on multi-revolution instruments such as clocks.

5.2.2.3.2.3.4 Number of pointers. Except for clocks or watches (which often have three hands), not more than two coaxial pointers should be used on a single dial indicator.

5.2.2.3.2.3.5 Aligned pointers for check-reading. When a stable value exists for given operating conditions in a group of circular-scale indicators, they should be arranged either in rows so that all pointers line up horizontally on the 9 o'clock position under normal operating conditions or in columns so that all pointers line up vertically in the 12 o'clock position under normal operating conditions. If a matrix of indicators is needed, preference should be given to the 9 o'clock position (see Figure 31).

5.2.2.3.2.3.6 Relative position of scale marks and numbers. When reading time and accuracy are critical, circular-scale markings and location of associated numbers should be arranged to prevent pointers from covering any portion of scale marks or numerals, and scale marks/numbers should be on, or close to the plane of the pointer tip to avoid visual parallax. If readout accuracy is not critical, such as when gross relationship between the pointer and the numeral is all that is required, an arrangement of numerals "inside" the scale annulus is acceptable. (see Figure 32).

5.2.2.3.2.4 Curved (arc) horizontal or vertical straight scales.

5.2.2.3.2.4.1 Scale reading and pointer movement. The magnitude of the scale reading should increase with movement of the pointer up or to the right and decrease with movement of the pointer down or to the left.

5.2.2.3.2.4.2 Zero position and pointer movement. The position of the zero value on curved or straight scales should conform to criteria in Figure 33.

5.2.2.3.2.4.3 Relative position of pointers, scales, and numerals. The numbers should be located on the side of the graduation marks opposite the pointer. The graduation marks should be aligned on the side of the pointer and stepped on the side of the numbers. The relative position of pointers, scales and numerals should conform to criteria in Figure 33.

MIL-HDBK-759B

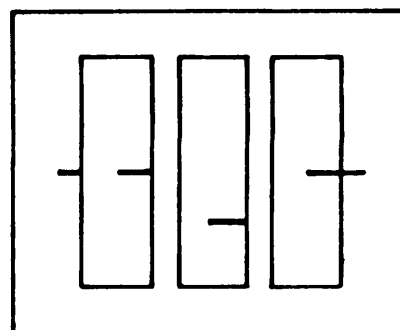
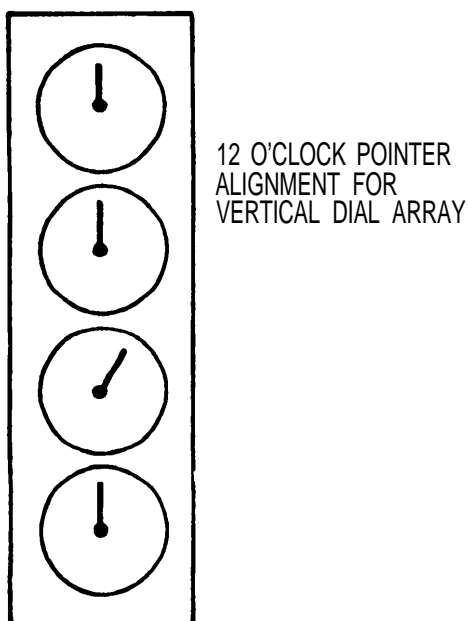
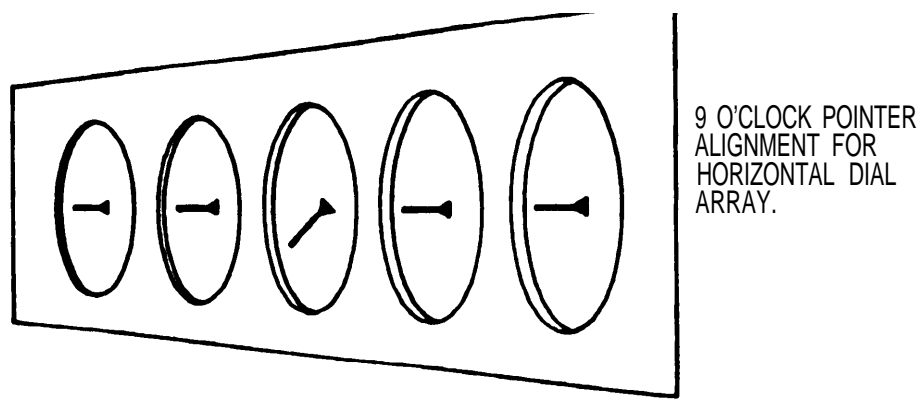

STRAJGHT-LINE SCALE FORMAT WITH "NOMINAL" OPERATING REFERENCE COMMON AMONG ALL DISPLAYS AT THE MID-SCALE POSITION. APPLICABLE ALSO FOR "MOVING-TAPE" INDICATORS.

FIGURE 31. Aligned pointers for rapid check-reading

MIL-HDBK-759B

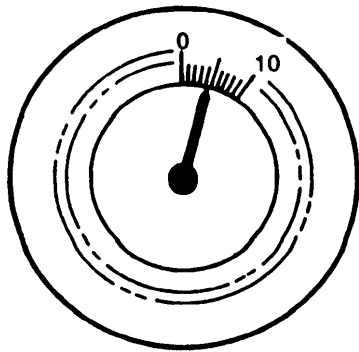

FOR MAXIMUM READING ACCURACY, NUMERALS SHOULD BE PLACED OUTSIDE THE SCALE, AND THE INNER ANNULUS OF SCALE MARKS PROVIDES AN "EVEN" BORDER, AGAINST WHICH THE POINTER TIP RIDES, SO THAT THE POINTER IS AN EQUAL DISTANCE (NOMINAL 0.8- 1.6 mm) FROM ALL SCALE MARKS, NEVER OVERLAPPING ANY MARK OR NUMERAL

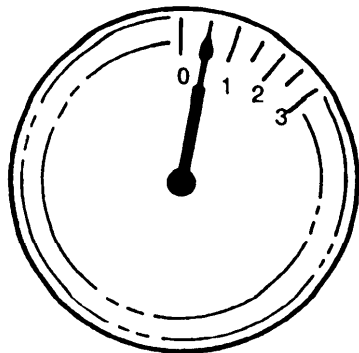

ALTERNATE FORMAT WHEN THE INSTRUMENT FACE IS SURROUNDED WITH A DEEP BEZEL, AND NUMERALS ARE INSIDE THE SCALE, SINCE GROSS READING OF NUMBERS IS PARAMOUNT.

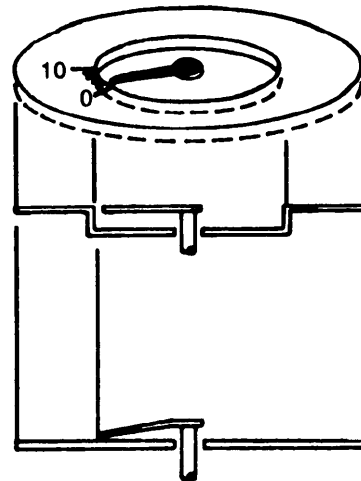

THE PLANE OF THE NUMERAL/SCALE INFORMATION SHOULD BE COINCIDENT WITH THAT OF THE POINTER TIP - OR AS NEAR AS IS PRACTICAL TO PREVENT OR MINIMIZE VISUAL PARALLAX.

FIGURE 32. Relative position of scale marks, numerals and pointers on circular dials

MIL-HDBK-759B



NUMERALS SHOULD BE LOCATED OUTSIDE SCALE MARKS, AND POINTERS SHOULD RIDE AGAINST THE INNER SCALE ANNULUS JUST SHORT OF THE MARKINGS. THE ZERO REFERENCE SHOULD BE TO THE LEFT SO THAT INCREASING NUMBERS AND POINTER MOTION IS CLOCKWISE.



ZERO REFERENCE (NULL) FOR ARC SCALE FORMATS SHOULD BE CENTERED ON THE SCALE, WITH POSITIVE VALUE INCREASE TO THE RIGHT OR UPWARD, NEGATIVE INCREASE TO THE LEFT AND/OR DOWNWARD A "MIRROR-IMAGE" OF THE VERTICAL FORMAT IS ALSO ACCEPTABLE.

RELATIVE LOCATION OF NUMERALS, SCALE, AND POINTER ON "STRAIGHT-LINE" DISPLAY FORMATS SHOULD BE AS SHOWN. POINTER SHOULD NOT COVER EITHER THE SCALE MARKS OR THE NUMERALS. THE POINTER SHOULD EMANATE FROM THE RIGHT SIDE OF THE VERTICAL FORMAT AND FROM THE BOTTOM OF THE HORIZONTAL FORMAT.

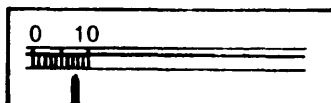
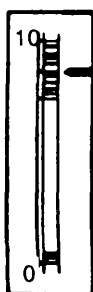

FIGURE 33. Relative position of scale marks, numerals and pointers on arc and straight-line scales

MIL-HDBK-759B

5.2.2 .3.2.4.4 Pointer alignment. When a common stable value exists for given operating conditions in a group of indicators, they should be arranged either in rows so that all pointers line up horizontally (for vertical scales) or in columns so that all pointers line up vertically (for horizontal scales).

5.2.2.3.3 Fixed-pointer, moving-scale indicators.

5.2.2.3.3.1 Open window display. When the display will be used primarily for "setting in a value" (tuning to a desired wavelength), only the portion of the scale of interest should be exposed. The rest of the scale is covered to reduce visual clutter and confusion. The open window should be of sufficient size to permit view of at least one numbered graduation either side of the desired setting. At least two number values should appear within the window at all times unless the scale is finite and the dial cannot be rotated continuously through successive rotations in the same direction. If the display will be used for tracking (as in the case of a directional indicator), the entire face of the dial should be exposed.

5.2.2 .3.3.2 Circular scales. There are ambiguities in associating moving circular scales with control movements; thus fixed-pointer, moving-scale indicators are not recommended. Moving circular scales necessarily violate one of the following principles of human engineering:

- a. Principle 1 - Scale numbers should increase in a clockwise direction. Values on moving circular scales should therefore increase with counterclockwise rotation of the dial face.
- b. Principle 2- The direction of movement of the associated control should be compatible with the direction of movement of the dial. (Clockwise movement of the control should result in clockwise movement of the dial.)
- c. Principle 3- Clockwise movement of a control should result in an increase.

If Principle 2 is compromised, such as when counterclockwise movement of the dial occurs, operators err in the initial direction of turn. If Principle 3 is compromised, a standard control movement-system relationship is violated. The following practices are recommended for designing circular moving scales to minimize the effects of incompatibilities:

- a. The numbers should increase clockwise around the face for controls without dial face masks. Therefore, the dial face moves counterclockwise to increase the readings.
- b. If the associated control has no direct effect on the performance of the equipment (tuning in radio stations), the scale should rotate counterclockwise (increase) when the associated knob or crank is turned counterclockwise.

MIL-HDBK-759B

- c. If the associated control has a direct effect on the performance of the equipment (speed or direction), the scale should rotate counterclockwise (increase) with a clockwise, upward or rightward movement of the associated control.

5.2.2.3.3.3 Straight scales moving vertically and horizontally. Straight scales that move vertically and horizontally exhibit the same direction-of-motion ambiguities as circular moving scales. The numbers should be printed so they increase from bottom to top, or from left or right on the scale plate itself. Then the scale should increase (move downward or to the left) when the associated knob or crank is moved clockwise, or when the associated lever is moved upward or to the right.

5.2.2.3.3.4 Accepted deviations. It is acceptable to deviate from the previously listed scale-design principles when other considerations have prime importance. Certain unique applications of scales may require other design features and compromises. For example, an azimuth indicator with the numerical progression of 30, 60, 90, is less satisfactory than those previously recommended. However, this arrangement represents a compromise between the best numbering progression and a manageable size of dial. Where the azimuth indicator is a small dial, the numbered cardinal points (north, east, south, west), serve as anchoring points in interpreting this indication and a progression by 30s is a good solution. Where the dial can be made large enough, the major intervals should be marked by 10s.

5.2.2.3.3.5 Non-linear scales. Non-linear scales condense a large range into a relatively smaller space, yet permit sensitive readings at certain critical ranges of the scale. When error tolerances are a constant percentage of the indication, a logarithmic scale is very suitable. However, logarithmic scales should show enough numbered graduation marks to prevent operators from reading the scale as if it were linear.

5.2.2.3.4 Moving-tape displays. When the scale length required for acceptable readout accuracy exceeds the limits of the capacity of the display package such as when compaction of scale markings would make the display illegible and/or subject to readout error, moving-tape scale format should be considered.

5.2.2.3.5 Composite scalar/pictorial displays. Combinations of scales, pointers, and/or pictorialized symbols may be used to combine functionally-related information into a single instrument or display (artificial horizon/ command heading, true/relative bearing and other similar combinations). Design of significant reference features (aircraft or ship symbols, horizon/attitude or pitch scales) should conform to the general criteria herein relative to direction-of-motion, scale-pointer relationships, and legibility. Color contrast should be used to aid the operator in differentiating among various elements of the combined or composite display, such as dark "land" vs light "sky".

MIL-HDBK-759B

5.2.2.3.6 Head-up display. The head-up display (a positional/command type of display typically projected on the primary windscreen of an aircraft cockpit to provide the pilot with flight direction information without him having to look down into the cockpit at instrument panel displays), may be considered with the approval of the acquiring activity. The head-up display concept should not be used for ground-borne or sea-borne vehicles or other operator control/display installations without express approval of the acquiring activity.

5.2.2.3.6.1 Display/external viewing interference. Markings projected on the windshield should be designed and illuminated in a manner that will not create confusion with external visual details required by the pilot for safe flight. Brightness control should be provided the operator, with sufficient latitude to set the brightness appropriately for the expected visual environment variations.

5.2.2.4 Cathode-ray tube (CRT) displays.

5.2.2.4.1 Applications. Cathode-ray tubes may be used for a wide variety of display purposes such as presentation of sensor data from radar and electronic-warfare systems, computer-generated data such as processed sensory data, target tracks, computer graphics, and status data. CRTs also may be used to show simulated exercises, aircraft system status, caution and warning indications, and presentation of television pictures. A CRT also may be employed for multiple uses in which case it should at least minimally satisfy the criteria for each use.

5.2.2.4.2 General guidelines. The following general guidelines apply to CRT selection and design regardless of specific use.

5.2.2.4.2.1 Screen luminance.

5.2.2.4.2.1.1 Operating range. The luminance used should be compatible with the CRTs operating characteristics and life expectancy. For example, the CRT should not be driven beyond its normal value in order to gain greater screen luminance since this could result in burning of the screen or in reduced life.

5.2.2.4.2.1.2 Ambient illuminance. CRT luminance should be compatible with the ambient illumination otherwise required in the work area, except that shielding, filtering, or use of a hood may allow lower CRT luminance if the technique employed is compatible with the operator's task. The ambient illuminance should not contribute more than 25% of screen brightness through diffuse reflection and phosphor excitation.

5.2.2.4.2.1.3 Controls. A control should be provided to vary the CRT luminance from 10% of minimum ambient luminance to full CRT luminance. A control should be provided to vary the luminous symbol/dark background or dark symbol/luminous background contrast ratio.

5.2.2.4.2.1.4 Operator visual capabilities and task criteria. Luminance of the faintest information displayed for operator response should be well above the

MIL-HDBK-759B

operator's threshold considering target size and presentation rate, clutter, phosphor color, and ambient illumination conditions.

5.2.2.4.2.2 Finish and luminance of surrounding area. Panel surfaces adjacent to the CRT should have a dull matte finish which under ambient operational conditions should have a luminance range between 10% and 100% of the screen background luminance. Some means of adjusting the surround luminance should be provided if necessary to ensure operation within this range.

5.2.2.4.2.3 Daylight viewing. CRTs which should be viewed under daylight conditions such as in an aircraft cockpit should utilize one or more appropriate means such as the following to bring viewing conditions within an acceptable range: (1) a deep shield or hood to reduce the amount of incident light, (2) scan conversion for continuous presentation at high luminance levels, (3) a high-output bum-resistant phosphor such as the P-1 compatible with the higher ambient light levels, (4) a circularly-polarized filter for cancellation of light reflected off the face plate, (5) negative image polarity to present dark traces on a light background, (6) a filter/phosphor combination which will minimize screen fluorescence (see Table 22), and (7) a fiber-optic or mesh-type filter which tends to reject incident light and pass screen-emitted light.

5.2.2.4.2.4 Reflection and glare. Reflection and glare off CRT face plates and cover plates should be minimized by one or more appropriate techniques such as: (1) shielding the CRT, (2) positioning light sources so they do not reflect off the CRT face plate into the operator's eyes, (3) use of a circularly-polarized filter for cancellation of light reflected in off the CRT face plate, (4) use of a cross-polarized lighting system (a polarizing filter over the CRT rotated 90° with respect to polarizing filters over the light sources), (5) use of a controlled ambient light system which delivers light only to the necessary work areas and baffles it from the CRT, (6) use of a selective spectrum lighting system wherein the spectral output of the CRT is substantially outside the spectrum of the ambient illumination, and (7) application of an anti-reflective coating on the CRT face plate and non-bonded filter surfaces to reduce the proportion of reflected light.

5.2.2.4.2.5 Use of color. Color is inherently a good coding dimension, but it should be utilized only when: any loss of CRT resolution resulting from the use of color is acceptable; color codes are compatible with color stereotypes and conventional usage; and all users will be able to perceive the code. (Because there are some color vision deficient personnel in the Armed Forces, it cannot be assumed that any random operator will be able to differentiate the color codes reliably. Use of some other code redundantly along with the color code is the best way to ensure that the codes will be differentiable by all personnel. Thus, if friendly and hostile tracks are to be differentiated by color, they should also be differentiable by some other means such as shape coding.)

5.2.2.4.2.6 Persistence. Transient signals of very short duration such as those derived from radar and active sonar systems should be displayed with sufficient persistence for the operator to perform whatever operations are needed with respect to the signals. Persistence beyond signal duration on the display may be accomplished.

MIL-HDBK-759B

TABLE 22. CRT phosphor applications and characteristics

Application	Phosphor I.D.	CIE Coordinates		Persistence	Fluorescence	Phosphorescence	Decay Time (m sec)	*Notes
		X	Y					
Radar Sonar, and Oscilloscope	P-1	.218	.712	Med.	Yellow Green	Yellow Green	24	*
	P-2	.279	.534	Med.	Yellow Green	Yellow Green	35-100	*
	P-7	.357	.537	Long	Yellow	Yellow Green		*
	P-10			Very Long	Dark Trace Screen			
	P-12	.605	.394	Med. Short	Orange	Orange		
	P-14	.504	.443	Med.	Yellow Orange	Orange		
		.150	.093	Med. Short	Blue	Orange		
	P-17	.302	.390	Long	Blue	Yellow		
	P-19	.572	.422	Long	Orange	Orange		*
	P-21	.539	.373	Med.	Red Orange	Red Orange		*
	P-25	.557	.430	Med.	Orange	Orange		*
	P-26	.582	.416	Very Long	Orange	Orange		*
	P-28	.370	.540	Long	Yellow Green	Yellow Green	500	
	P-29	(P-2 + P-25)		Med.	Green	Green		
	P-31	.193	.420	Med. Short	Green	Green	4	*
	P-32			Long	Purple Blue	Yellow Green		
	P-33	.559	.440	Very Long	Orange	Orange		*
	P-34	.235	.364	Very Long	Blue Green	Yellow Green	40 sec	*
	P-35	.286	.420	Med. Short	Green	Blue		*
	P-38	.561	.437	Very Long	Orange	Orange	1040	*
P-39	.223	.698	Long	Yellow Green	Yellow Green	150	*	
P-40	.276	.3117	Med.	White/Blue	Yellow Green			
Monochrome	P-4	.270	.300	Med. Short	White	White	25	*
	P-23	.375	.390					
Color TV	P-22	.155	.060	Med.	Blue	Blue	25	
		.285	.600	Med.	Yellow Green	Yellow Green	60	
		.675	.325	Med.	Orange Red	Orange Red	0.9	

TABLE 22. CRT phosphor applications and characteristics - continued

Application	Phosphor I.D.	CIE Coordinates		Persistence	Fluorescence	Phosphorescence	Decay Time (m sec)	*Notes
		X	Y					
Projection TV	P-18	.333	.347	Med.				
Storage Tubes	P-20	.444	.536	Med. Short	Yellow Green	Yellow Green		
Persistence:								
Very long = 1-second or over								
Long = 100 msec-1.0 sec								
Medium = 1 msec to 100 msec								
Medium short = 10 μ sec to 1.0 msec								
Short = 1 μ sec to 10 μ sec								
Very short = less than 1 μ sec								
*Notes								
P-1 - High efficiency, resolution, and resistance to burn.								
P-2 - Decrease in decay with increase in beam current.								
P-4 - Sulfide version.								
P-7 - High efficiency and resistance to burn.								
P-19 - Slow refresh rate for flickerless display; low-light output; low-burn resistance.								
P-25 - Desired low-level persistence, high resistance to burn; low-light output.								
P-26 - Slow refresh rate for flickerless display; low-light output and burn resistance.								
P-31 - Curve has blue peak at 450 nanometers; high efficiency, resolution and resistance to burn.								
P-33 - Decay decreases with beam current decreases; burns rapidly when used with stationary or slow-moving beam.								
P-34 - IR stimutable; Y-phosphor.								
P-35 - Resists burning compared to P-11.								
P-39 - Similar to P-1 but with longer decay.								

MIL-HDBK-759B

through use of persistent phosphors, periodic repainting (refreshing) of the image from processor memory, or utilization of scan converters or direct view storage tubes as appropriate to the application. With rotating sweep indicators, the persistence should be at least such as to display even faint signals above threshold for a period equal to one-quarter of a sweep rotation. Short to medium persistence is adequate for scan rates such as those used for television.

5.2.2.4.2.7 Dynamic range. A dynamic range of at least 7 dB should be provided for detection of targets on a plan-type indicator, and 20 dB or more is desirable for detection on an A-scan presentation or other deflection display. A dynamic range of at least 7 dB should be provided for TV images, and applications where fine-grain detail is important, such as high-resolution reconnaissance sensors, should provide the maximum attainable with the state-of-the-art.

5.2.2.4.2.8 Jitter. Erratic movement of sweep traces on CRT displays should be diminished to the point where it is not detectable by the operator.

5.2.2.4.2.9 Flicker. The refresh (repaint) rate of signals or data displayed on a CRT should not be between the rates of 7 Hz and 28 Hz except in applications requiring sensor scanning at these rates and as noted in 5.2.2.4.5.1.3. Rates between 1 and 7 Hz should be utilized only when it is desired to capitalize on the conspicuity value of such rates, such as for warning signals or in the rare circumstances when flash rate coding might be utilized. Refresh rates for data which are to be perceived as continuously presented should be adjusted upward from 28 Hz as necessary to reduce flicker to a non-detectable level over entire range of display luminance.

5.2.2.4.2.10 Spot size and resolution. The spot size (diameter to 10% luminance) on a CRT should be compatible with the signal characteristics and type of scan to be utilized. For radar the spot size preferably should be smaller than the minimum size of a returned pulse as presented on the slowest sweep (longest range scale) in order to avoid loss of resolving power inherent in the radar system. For most CRT display applications spot diameter at all parts of the screen should subtend no more than one minute of arc from the normal viewing position. Alphanumeric characters should be scaled to subtend at least 15 minutes of arc; other complex shapes should subtend at least 20 minutes of arc.

5.2.2.4.2.11 Hand-capacitance effects. For applications where the operator's hand normally comes close to the screen, such as in plotting on the face plate or in using a light pencil for data pickoff, aluminized backing of the screen should be utilized so as to minimize the effect of hand capacitance which tends to add uncontrolled deflection to the CRT beam.

5.2.2.4.2.12 Burning of screen. The display design should minimize the likelihood of burning of long persistence phosphor screens such as the P-19 and P-33, since it cannot be assumed that burn-damaged CRTs will always be properly replaced under operational conditions, and the presence of burned areas seriously degrades display legibility. Anti-burn techniques include use of aluminized backings and protective circuits for automatic intensity reduction whenever the beam remains stationary.

MIL-HDBK-759B

5.2.2.4.2.13 Distortion. Sweep non-linearity with raster on plan-type scans should be less than 20%. CRTs displaying only alphanumeric or graphics should show no obvious distortion in any column or row of characters, and the character aspect ratio should appear to be constant at all parts of the screen.

5.2.2.4.2.14 Screen shape. CRT display surfaces used exclusively for data presentation of computer graphics should be rectangular in shape. CRT displays used exclusively for TV image presentation should also be rectangular and should normally follow the standard practice of having a 3:4 aspect ratio (height to width). Those CRTs used exclusively for polar plots of sensor data should be round. The preferred display surface shape for A-scan presentations is rectangular. CRTs used simultaneously or sequentially for two or more different display functions may have round, square, or rectangular display surfaces as best fit the combined purposes.

5.2.2.4.2.15 Useful screen diameter. The diameter of direct-viewing console-mounted CRTs should normally be within the limits listed below.

- a. For detection of signals from sensor systems: 215 mm +/- 40 mm.
- b. For both detection and tracking: 300 mm +/- 50 mm.
- c. Tactical or situation displays: at least 380 mm maximum 760 mm.
- d. Alphanumeric displays: size these by considering the largest format which will be required and the recommended character size.
- e. TV: minimum 120 mm, maximum 600 mm.
- f. Single character display: 20 mm minimum.
- g. Display of single pulse or short sweep segment for qualitative monitoring only: 20 mm minimum.

(Smaller CRTs than those listed for detection, detection and tracking, and situation display may be used where there are severe space constraints such as in aircraft or submarines or hand-held units.)

5.2.2.4.2.16 Viewer protection. A transparent safety screen which may be integral with the CRT face plate should be provided to prevent implosion injury. Protection as needed should also be provided against low-intensity X-radiation as prescribed by current regulations.

5.2.2.4.2.17 "Housekeeping" controls. The number of "housekeeping" controls (focus, intensity, and centering) to be used by the operator for adjustment of the CRT should be kept to a minimum. Such controls which are to be used by the operator (as opposed to a maintenance technician) should be finger-operated and available from the front panel but recessed and preferably covered when not in use.

MIL-HDBK-759B

5.2.2.4.2.18 Display composition features. Convenient controls should be provided for structuring the display format and content in accordance with user criteria. Display capability should be provided to present both the current settings of all controls relating to display composition, and the total range of settings available.

5.2.2.4.2.19 Viewing angle. CRT screens should be perpendicular to the operator's line of sight (have a 90° viewing angle at screen center) whenever feasible and no part of any screen including secondary CRTs should offer a viewing angle of less than 45° from the operator's normal position.

5.2.2.4.3 Special criteria for TV displays.

5.2.2.4.3.1 Resolution. Resolution should be 400 lines or greater, both horizontally and vertically, except for low-resolution applications where line spacing need not be closer than needed to subtend one minute of arc from the normal viewing position.

5.2.2.4.3.2 Frame rate and interlacing. Except for slow-scan systems for reproduction of static images, the frame rate for sampling of video material should be a minimum of 30 Hz. There should be two display scans (fields) per frame period (or a minimum of 60 Hz) with the lines of the second scan in the frame period interfaced with the lines of the first scan.

5.2.2.4.3.3 Phosphors. The phosphors for tv screen should have short or medium persistence and high output (the P-4 or P-23 for black and white monitors, and the P-22 or P-27 for color monitors).

5.2.2.4.3.4 Distortion. Spot diameter should not vary by more than a ratio of 3:2 at any two points on the screen. Distortion should not be sufficient to cause obvious non-linearity anywhere on the screen when viewing alphanumeric formats or picture images.

5.2.2.4.3.5 Gray scale. There should be a minimum of at least five distinguishable gray scale levels. When the criteria include interpretation of handwriting, resolution of fine detail, or complex image interpretation, up to eight gray scale levels should be provided.

5.2.2.4.4 Special criteria for sensor displays.

5.2.2.4.4.1 Types of scans. The type of scan selected should be appropriate to the operator's task in utilizing the sensor data. Commonly used scan types should be selected in preference to novel or experimental scan types except as approved by the acquiring activity.

MIL-HDBK-759B

5.2.2 .4.4.2 Display scale sizes and range ring values. Display scale should be selected on the basis of the following criteria:

- a. If rings are to be used, the display scales selected should be compatible with use of a constant number of range rings regardless of scale, as follows:

<u>3 Range Rings</u>	<u>4 Range Rings</u>	<u>5 Range Rings</u>
Any decimal multiples of:	Any decimal multiples of:	Any decimal multiples of:
15 unit scale	4 unit scale	5 unit scale
30 unit scale	8 unit scale	10 unit scale
60 unit scale	20 unit scale	25 unit scale

Display systems capable of presenting alphanumeric should present range ring values on the CRT.

- b. Appropriate scale limits considering sensor characteristics such as maximum range, range resolution, bearing resolution, and maximum range of detection (see 5.2.2.4.4.4). For example, the display scales for use with a shipboard surface search radar having a minimum range of 200 m and a maximum range of 60 km might be as follows:
- (1) Minimum -2 km (not more than 10 times the minimum range value, to capitalize on range determination at close-in ranges as in station keeping).
 - (2) Maximum -75 km (accommodates maximum range of the radar and is a good scale for estimation and interpolation).
- c. Area and scaling limits suggested by representative operational situations including warfare operations, search patterns, maneuvers, and flight operations. For example, an air traffic control center which may have a number of missions involving close-in aircraft operations at ranges from 15 to 30 km should have a 30 km display scale for monitoring and control of aircraft on such missions.

5.2.2.4.4.3 Offset. Provision for offsetting display center should be made if it is expected that operators may find it advantageous to sometimes confine their attention to an expanded portion of the display which would not be centered on the sensory location. The preferred way of offsetting is through positioning a CRT marker that centers the new display with a two-coordinate controller and activates it with an entry switch. If the amount of offset is sufficient to displace the original display center off the scope, then a simple means of recapturing the original center should be provided.

MIL-HDBK-759B

5.2.2.4.4.4 Resolution, signal size, and viewing distance. In general, the display should present sensor signals with sufficient display resolution to match the resolution of the system. (A precision radar needs a high-resolution display but a mosaic of infrared detectors can suffice with a much lower display resolution.) The signal size should be sufficient to provide a subtended visual angle for the target of at least 12 minutes of arc for the normal position of the viewer. When the target is of complex shape and recognition is required, it should subtend no less than 20 minutes of visual angle and at least 10 lines or resolution elements (25 minutes in presence of heavy noise or clutter).

5.2.2.4.4.5 Reference and boundary marks. Provision may be made for range rings, grid marks, azimuth markings, map outlines, operational boundaries, and velocity vectors as appropriate for the intended operational situation. When such aids are provided they should be selected as needed, parallax-free, and controllable in intensity. There should be no more than five range rings on a plan-type indicator.

5.2.2.4.4.6 Operator loading. In planning the number of detection and tracking displays which may be needed in a system, the following criteria should be considered.

- a. Detection performance decreases as the amount of target activity increases. Detection displays should not require monitoring of more than four concurrent and independent detection situations by an unaided operator.
- b. In a computer-based system relying upon operator updating of target positions, individual displays should not require tracking of more than six independent air targets or more than 15 independent surface targets. Systems which will be employed in situations where there may be groups of targets moving with common velocities should be capable of presenting computer-aided tracking aids such as raid-forming gates which treat the entire group as a single target for tracking purposes.
- c. Systems performing automatic detection and tracking should provide sufficient display capability to accommodate an appropriate level of operator monitoring for manual backup in case of computer failure. (see 5.2.2.4.5.11.3.)

5.2.2.4.4.7 Automatic sequencing. Computer-aided display systems may provide priority-ordered automatic sequencing to facilitate manual track position updating or other recurrent manual operations. With automatic sequencing, each time a position update is entered by the operator, a marker on the display steps to the position of the next track needing updating.

5.2.2.4.4.8 Data readout. Computer-aided display systems should provide convenient operator-oriented facilities for readout of selected information on demand. In tactical data systems this may involve use of a two-coordinate controller to designate specific tracks on the CRT for readout, and an auxiliary display presenting formatted information held by the computer concerning the designated track.

MIL-HDBK-759B

5.2.2.4.4.9 Handover. Computer-aided display systems should provide convenient means for transferring responsibilities between operators (handover of targets on the basis of sector transit or operator overload).

5.2.2.4.4.10 Display gates. Computer-aided systems may provide display gates controllable in size and position by the operator to designate areas within which signal return is blanked out (censored) or identified as calling for special processing.

5.2.2.4.5 Special criteria for computer-generated displays.

5.2.2.4.5.1 Display of processed sensor data.

5.2.2.4.5.1.1 Quantized data. Systems which process and quantize sensor data before presenting it to an operator for detection should provide a minimum signal size on the display of 12 minutes of visual angle for the viewer's normal position, display coding to maximize the opportunity to discriminate signals from noise, and operator control to electronically mark points to be monitored, correlated, entered, or dropped.

5.2.2.4.5.1.2 Time-integrated data. Systems which accumulate processed data and present all or part of that history in integrated fashion on current scans should provide controls for adjusting the amount of data history to be displayed, means to differentiate the most recent data from the older data, and operator control to electronically mark points to be entered or dropped.

5.2.2.4.5.1.3 Time-compressed data. Systems which accumulate processed data and present all or part of that history in accelerated sequential playback should provide controls for adjusting the amount of data history to be displayed, adjusting playback rate between the limits of 12 and 30 frames per second, and electronically marking points to be entered or dropped. (For most applications the minimum number of scans to be displayed in a sequence should be six or more.)

5.2.2.4.5.2 Alphanumeric characters.

5.2.2.4.5.2.1 Character generation. Provided they meet the legibility guidelines in 5.2.2.4.5.2.2, characters may be generated by any of the commonly used techniques including the following:

- a. Stroke generation, in which the character is drawn by deflecting the CRT beam through a series of connected line segments.
- b. Lissajous generation, in which the beam is deflected through a sequence of segments of lissajous figures.

MIL-HDBK-759B

- c. Facsimile generation, in which character shapes are stored in analog form as a mask within the CRT and are used to shape the electron beam.
- d. Dot matrix generation in which an electronically stored dot matrix memory is used to intensity-modulate the beam as it scans the character space.

5.2.2.4.5.2.2 Legibility criteria. CRT-presented characters should be designed to avoid "look-alike" pairs which might be confused with one another (B and 8, 5 and S, 0 and D.) Characters should generally conform to the legibility criteria specified in 5.2.2.6.1.2 when:

- a. stroke width on CRTs for single-operator use may be determined by the normal width of a stroke on the CRT rather than by a fixed ratio of stroke width to height,
- b. minimum character height on raster scans should be seven raster lines.

5.2.2.4.5.3 Symbols and symbol modifiers. Symbols and their modifiers which are presented on CRTs should meet the following criteria.

- a. Except for dots, small circles, and keyboard generated symbols such as the dash, quotation marks, and commas, minimum height of symbols should at least equal the minimum height for characters as specified in 5.5.1.6. Minimum symbol height on raster scans should be at least seven raster lines.
- b. Color coding of symbols should be used only redundantly with some other coding technique. (For example, if shape coding is utilized to differentiate between hostile and friendly tracks, color coding may also be used to enhance the difference, but color coding should not be used as the sole means of differentiation.)
- c. Selection of a symbol set and modifiers should be based on the following criteria:
 - (1) Symbols and modifiers should reflect the interrelationships among the data in the set to be represented by a circle, an engaged target should be presented as a modified circle (a circle with a bar across it) rather than as a completely different symbol (a triangle).
 - (2) Clear differentiation should be maintained between basic symbol types, between modified symbol types, and between modified and unmodified symbols.
 - (3) No more than five variations (three preferred) in a single dimension (hue for color coding) should be utilized in any set of symbols which should be discriminated from one another on an absolute basis (without side by side comparison).

MIL-HDBK-759B

5.2.2.4.5.4 Refresh rates. Except for time-compressed data and warning or alerting signals, all data on CRTs should be displayed at refresh rates of at least 28 Hz or greater as needed to prevent noticeable flicker.

5.2.2.4.5.5 Display-composition features. Convenient controls should be provided to allow the operator to select the categories of information which are needed for independent display and to determine how the selected information should be displayed (normal symbology, dots only, intensified, blinking, if this type of selective control over presentation mode is needed by the operator for task performance). Controls should be on an alternate action basis so that one switch action adds the category and the alternate action removes it (as opposed to two independent controls, one to add, and the other to remove.) Positive indication should be provided at all times for the state of the display-composition switches. (The operator needs to be able to conveniently read out at any point in time precisely how the display has been structured.)

5.2.2.4.5.6 Operator/computer interaction. The opportunity for constructive use of operator/computer interaction should be considered for the following situations (as applicable):

- a. generation of trial solutions to tactical
- b. generation of free-drawn graphics,
- c. solution of relative motion problems,
- d. construction of formatted messages,
- e. editing of messages.

5.2.2.4.5.7 Data readout. Computer-generated display systems should provide convenient operator-oriented means for readout of selected information on demand. In tactical data systems this may involve use of a two-coordinate controller to designate specific tracks for readout, a keyboard for entry of instructions to the computer, sophisticated computer algorithms for processing information per operator request, and displays for presenting formatted information in response to track oriented or other information requests.

5.2.2.4.5.8 Handover. Computer-generated display systems should provide convenient means for transferring responsibilities between operators (complete handover of responsibility as in shutting down a console, or handover of individual targets on the basis of sector transit, engagement status, or operator overload).

5.2.2.4.5.9 Interdisplay pointing. Incorporation of interdisplay pointing should be considered to allow each operator to position a display marker and drive one or more slaved markers on other displays as selected, to facilitate communication regarding areas of interest.

MIL-HDBK-759B

5.2.2.4.5.10 Composition and editing of messages. When the computer is used to assist the operator in composing and/or editing CRT-displayed messages the following features should be provided:

- a. a cursor on the display (a line beneath a character) to identify where the operator is in the sequence,
- b. controls as needed to allow rapid positioning of the cursor,
- c. selection capability for standard message formats,
- d. automatic composition of those parts of standard formats for which the computer has the data.

5.2.2.4.5.11 Automation of functions.

5.2.2.4.5.11.1 Criteria for automation. Automated systems should be used to:

- a. prevent operator saturation as in the detection and tracking of large numbers of targets in a surveillance system,
- b. detect events (targets, signals) when the frequency of occurrence is very low and the unaided operator cannot maintain the required vigilance over the long period of time between events, and
- c. replace manual functions wherever the capabilities of the automated system are clearly superior to those of a purely manual system.

5.2.2.4.5.11.2 Data filtering for monitoring automated functions. Display used exclusively for monitoring automated functions should operate on a discrepancy or "management by exception" basis wherein only those data which deviate from expectation according to system mode and operational conditions are displayed. (This includes data on processor function as well as operational data.)

5.2.2.4.5.11.3 Data presentation for manual backup. In systems where manual backup may be required in case of computer failure, the backup display should not operate strictly on a discrepancy basis but rather should present sufficient data to keep the operator advised of the current state of processing and to provide all the baseline data which would be needed to initiate manual operation at any point in time.

5.2.2.4.5.11.4 Timely data processing and display. Automated systems should be designed to:

- a. respond to operator information requests and control inputs in a timely manner,
- b. impose minimal burden on the operator for routine aspects of data management, and

MIL-HDBK-759B

- c. present routine information to the operator on a time-phased basis related to the task sequence but present urgent information on an interrupt basis using alerting techniques.

5.2.2.4.5.11.5 Electronically or optically generated displays. Electronically or optically generated displays should conform to MIL-STD-884.

5.2.2.5 Large-screen displays.

5.2.2.5.1 Application. Large-screen displays may be used in the situations listed below:

- a. when group of operators frequently refer to the same information and are required to interact as a team, based on the same information,
- b. when one or more members of a team of operators have to move about, yet require frequent referral to information required to make decisions, but which they cannot carry with them, or do not have displayed at their assigned position(s),
- c. when there are space or other constraints that preclude the use of individual displays for each team member to call up commonly-used information,
- d. when it may be desirable to have general information available to persons who should not interrupt on-going group operations by looking over the shoulder(s) of individual operator(s) to see their individual displays.

5.2.2.5.2 Avoidance. Large-screen displays should not be used when the spatial and environmental conditions do not allow satisfactory observational geometry to ensure that all critical operators have appropriate visual access in terms of viewing distance, angle and lack of interference from intervening objects or personnel and/or ambient lighting.

5.2.2.5.3 Angle of view. All critical display observers should be able to view the display as perpendicularly as possible, and in no case at an angle of less than 40° from the plane of the screen.

5.2.2.5.4 Viewing distance. The display should not be placed further from an observer than will provide appropriate resolution of critical detail presented on the display (see 5.5), and the display should not be closer to any observer than 1/2 the display width or height, whichever is greater.

5.2.2.5.5 Physical interruption of view. Large-screen displays should not be located with respect to critical observers so that view of the display is obscured regularly by persons moving about (normal traffic patterns).

MIL-HDBK-759B

5.2.2.5.6 Control of displayed information. Large-screen group display systems should be designed so that critical information cannot be modified or deleted inadvertently or arbitrarily; therefore:

- a. changes in the group display should be controllable by designated operators who operate according to pre-established procedures and/or upon command of a person in charge,
- b. separate remote displays should be provided for operators who should make changes in display format or content which would be disruptive to other operators, and
- c. display composition features should be provided as appropriate for monitoring and control of display format and content.

5.2.2.6 Other Displays.

5.2.2.6.1 General.

5.2.2.6.1.1 Applications. Where applicable, other display concepts, devices and/or techniques should be considered, including the following:

- a. digit light arrays to monitor "countdown" operations,
- b. drum-type, mechanical counters to display discrete numerical values, but non-trend information,
- c. character readout devices (stacked edge-lit, back-projected, gas-discharge tube, CRT, plasma, liquid crystal display (LCD), light-emitting diode (LED)) that present alternate characters (numerical, letters, or numerals and letters) within the same viewing envelope, which may be used in conjunction with, or in lieu of (a) or (b) above,
- d. mechanical flags incorporated within an instrument to indicate that the instrument is in a go vs no-go condition,
- e. plotters and recorders to provide visual record of continuous graphic data,
- f. printers for producing hard copy records from manual or computer input,
- g. optical projection systems to present static and/or dynamic information for large screen, group viewing, projection of guidance information on a vehicle windscreen (head-up display), and for display of composite situation information.

5.2.2.6.1.2 Visibility and legibility. Basic visibility and legibility criteria for other displays described herein should also apply to the above displays, See 5.2.2.1.1 for criteria on display illumination.

MIL-HDBK-759B

5.2.2.6.2 Special criteria.5.2.2.6.2.1 Digit light arrays.

5.2.2.6.2.1.1 Arrangement. Digit light arrays used for other than countdown purposes should be arranged in normal single line format with increasing numbers from left to right or from top to bottom. The sequence for countdown operation should be reversed so that the numbers decrease from left to right or from top to bottom (see Figure 34).

5.2.2.6.2.1.2 Spacing. Lights should be spaced as follows:

- a. Minimum = one half the diameter of the indicator light.
- b. Maximum = equal to the diameter of the indicator light.

5.2.2.6.2.1.3 Color and contrast. Black numbers on a white background should be used (unless specific approval for a reversed contrast or colors is given by the acquiring activity). Adjacent panel surface should appear darker than the lighted indicator (a minimum contrast of 50 percent), and the surface should have a dull or matte finish.

5.2.2.6.2.2 Counters.

5.2.2.6.2.2.1 General. Counters should be used for presenting large ranges of quantitative data where operators must make quick, precise, readings, but need not keep track of continuous trends. The numbers should change by snap action, rather than continuously. If the operator must read numbers consecutively, numbers should not change faster than twice a second. Odometers and hour meters are exceptions to this rule.

5.2.2.6.2.2.2 Reset. Counters used to indicate sequencing of equipment should be designed so they reset automatically when the sequence is completed. Manual resetting should also be provided and the knob should rotate clockwise to increase the reading displayed, or to reset the counter. Where push buttons are used to manually reset mechanical counters, actuating force required should not exceed 16.7N.

5.2.2.6.2.2.3 Numbers. Numbers on counters should read horizontally, from left to right, rather than vertically. Large horizontal spacing between number drums should be avoided. Normal spacing should be between one-quarter and one-half of the numeral width.

5.2.2.6.2.2.4 Color. When only a small area of the counter drum is visible around each number, the counter frame should be the same color as the drum.

MIL-HDBK-759B

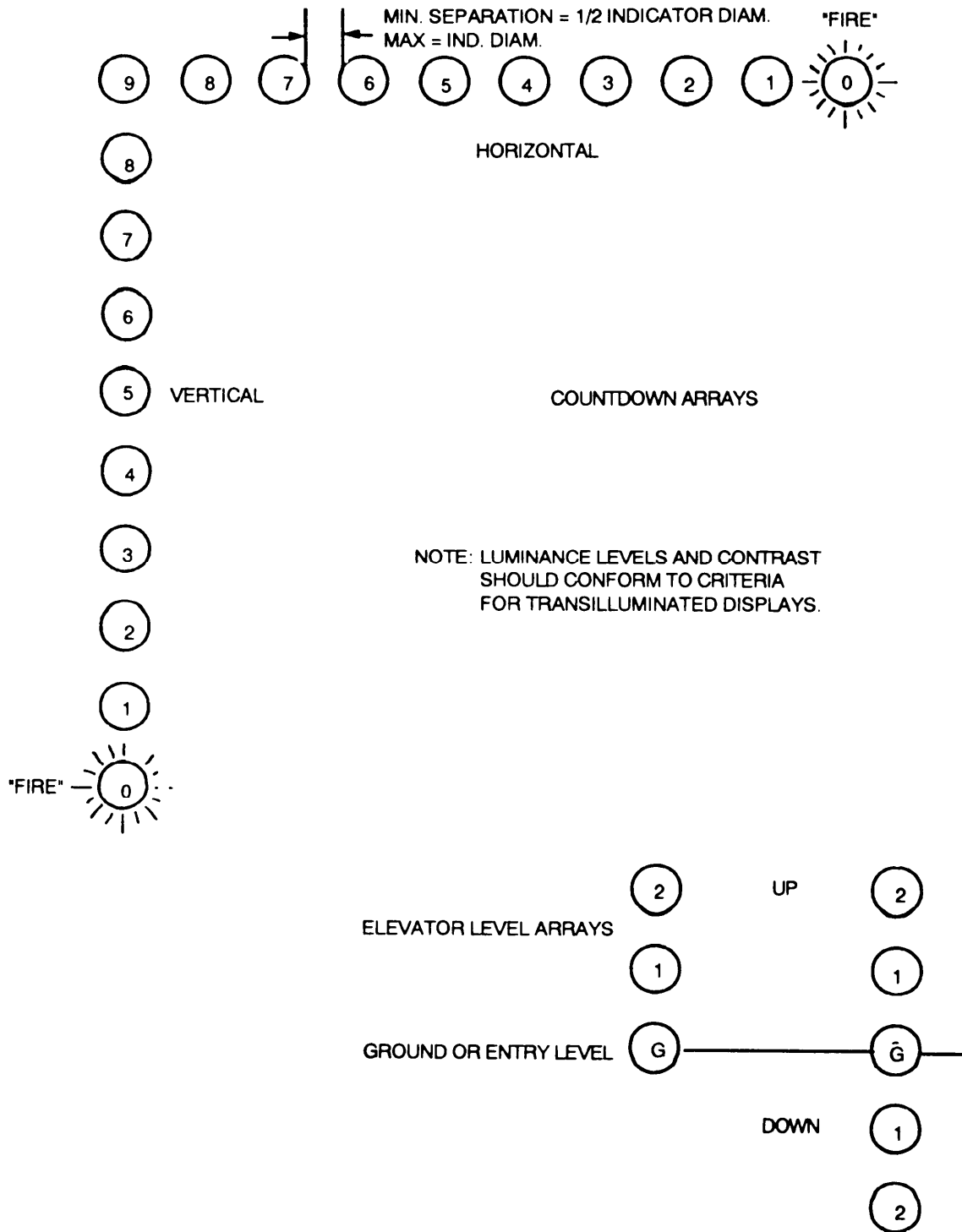

FIGURE 34. Digit light counter arrays

MIL-HDBK-759B

5.2.2.6.2.2.5 Placement. Counters should be mounted as close to the panel plane as possible to minimize parallax and shadows and to permit reading from the sides. Table 23 shows the character sizes that should be used for counters viewed from various distances and under different illumination levels.

TABLE 23. Character sizes for mechanical counters (mm)

Viewing Distance	Height	Width	Stroke Width	Minimum Separation Between Numerals
Normal Illumination (above 3.4 cd/m ²)				
710	3.80	3.80	0.94	0.64
910	4.80	4.80	1.20	0.81
1525	7.90	7.90	1.30	1.30
Low Illumination (0.1 to 3.4 cd/m ²)				
710	5.60	5.60	0.94	0.94
910	7.10	7.10	1.20	1.20
1525	13.00	13.00	2.10	2.10

NOTE: For reading distances closer than 710 mm, characters should be at least 3 mm high.

5.2.2.6.2.2.6 Drum-type, mechanical counters. Mechanical, drum-type counters should conform to criteria in Figure 35.

5.2.2.6.2.3 Character-generating devices.

5.2.2.6.2.3.1 General. In making a selection from among the several types of readout devices, consideration should be given to the limitations of each device in terms of available brightness, colors, and reading speed and accuracy. For example, the character legibility of some indicators is better than others. The list below should be used as a guide.

- a. Devices that produce continuous-line characters provide the opportunity to maximize key legibility parameters, such as height-to-width ratio, stroke width, luminance contrast and color.
- b. Devices that produce characters by means of dot or line segment patterns limited in terms of the above legibility parameters. Dot patterns are more readable (see Figure 36).

MIL-HDBK-759B





- a.  a. COUNTER DRUMS SHOULD BE NUMBERED SO THAT A CLOCKWISE ROTATION OF DRUMS AND/OR RESET CONTROL PRODUCE INCREASING NUMERICAL VALUES. NUMERALS SHOULD "SNAP" INTO POSITION SO THAT THE ENTIRE NUMERAL APPEARS WITHIN THE VIEWING WINDOW. NUMBER HEIGHT: WIDTH PROPORTIONS SHOULD BE WITHIN THE RANGE OF 5:3 TO 1:1. (1:1 IS THE PREFERRED RATIO) EXCEPT FOR NUMBER '1'.
- b.  b. SPACING BETWEEN ADJACENT NUMERALS SHOULD NOT EXCEED 1/4 WIDTH OF WIDE NUMERALS; 1/2 WIDTH OF NARROW NUMERALS WHEN SEVERAL NUMBERS ARE TO BE READ AS A TOTAL VALUE,
- c.  c. COUNTER DRUMS SHOULD BE MOUNTED AS CLOSE TO THE FRONT PANEL SURFACE AS PRACTICAL AND THE EDGES OF THE VIEWING WINDOW SHOULD BE BEVELED TO PROVIDE AT LEAST 45° OFF-ANGLE VIEW OF THE DISPLAY.
- d.  d. WHEN NUMBERS ON RIGHT DRUMS NEED NOT BE READ ACCURATELY, THESE MAY MOVE IN A CONTINUOUS MOTION-IN WHICH CASE AT LEAST TWO OF THE NUMBERS SHOULD BE VISIBLE.
- e.  e. DECIMAL POINTS MAY BE INSERTED WITHIN THE VIEWING WINDOW OR PLACED ON THE PANEL WHEN THE POSITION REMAINS CONSTANT. COMMAS SHOULD NOT BE USED UNLESS MORE THAN FOUR NUMBERS APPEAR IN THE WINDOW.
- f.  f. IF LEFT-HAND NUMBERS ARE SELDOM USED, A BLANKING SYSTEM SHOULD BE PROVIDED RATHER THAN PRESENTING SEVERAL PRECEDING ZEROS (THE BLANKING DEVICE ONLY EXPOSES LEFT-HAND DRUMS WHEN NUMERICAL VALUE IS DISPLAYED).

FIGURE 35. Drum-type counter design

MIL-HDBK-759B

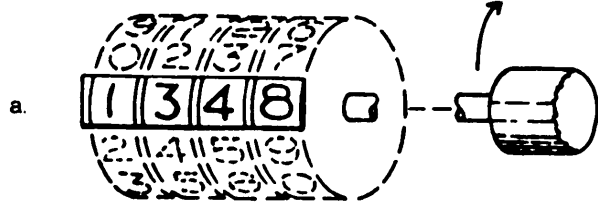

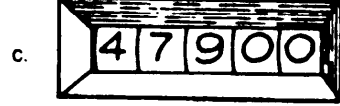
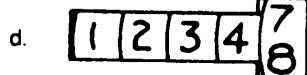
5 x 7 DOT MATRIX MAYBE USED FOR BOTH LETTERS AND NUMERALS, AS WELL AS OTHER SYMBOLS. A 7 X 9 IS PREFERRED WHEN ACCURACY IS OF PARTICULAR IMPORTANCE FOR ALPHANUMERIC DATA SETS.

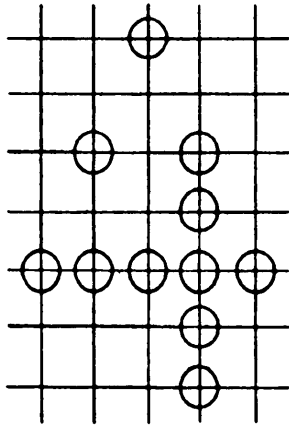
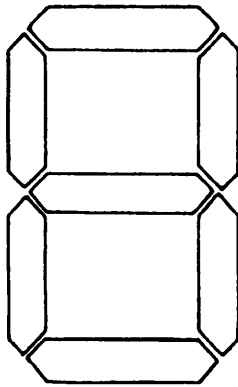

7-SEGMENT BAR-IVPE MATRIX IS ACCEPTABLE FOR NUMERALS, BUT CANNOT PROVIDE A FULL ALPHABET OF LEVERS.

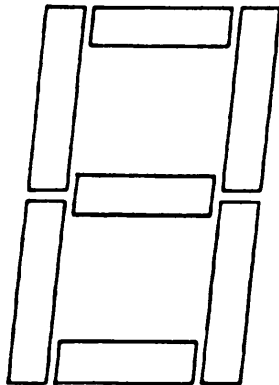

ITAUC OR SLOPING MATRIX IS ACCEPTABLE AS LONG AS THE SLOPE DOES NOT EXCEED 110.

FIGURE 36. Minimal criteria for dot and segmented matrix characters

MIL-HDBK-759B

- c. Depending on the state-of-the-art for a given device, some devices may be too large or too small for the particular application, such as panel space limits or viewing distance limits.

5.2.2.6.2.3.1.1 Alphanumeric character format. Characters and symbols should appear upright or slope slightly (up to 110, to the right. Legibility/ readability of unusual formats should be equivalent to that of standard Gothic capital letters and numerals.

5.2.2.6.2.3.1.2 Contrast direction. Character generation techniques should be chosen to best fit the operating environment.

- a. Light symbols on a dark background should be used when work area illumination is low (less than about 3.4 cd/m²).
- b. Either a light or dark background should be chosen for intermediate illumination levels.
- c. Dark symbols on a light background is preferred when ambient light conditions are high (more than about 3400 cd/m²).

5.2.2.6.2.3.1.3 Indicator spacing. Devices which are subject to glare problems (stacked edge-lit, gas-discharge tubes) should be designed to minimize intersurface reflections, halo effects around glow wires or engravings, and "hot spots" from lamp sources. When the particular display may be affected by external (ambient) light reflections, filters and/or anti-reflection coatings should be provided.

5.2.2.6.2.3.1.4 Lamp replacement. Devices which depend upon incandescent lamp sources should be packaged for ease of lamp replacement,

5.2.2.6.2.3.1.5 Intensity Control. Digital readout devices that may be used under dim-out or blackout operating conditions should be selected on the basis that operator-controlled dimming should be provided.

5.2.2.6.2.3.2 Light-emitting Diodes (LEDs).

5.2.2.6.2.3.2.1 General. In general, the standard for LEDs will be the same as the criteria for Transilluminated Displays in 5.2.2.2 unless specified below.

5.2.2.6.2.3.2.2 Application. LEDs should be used for transilluminated displays, including legend and simple indicator lights, and for matrix (alphanumeric) displays. LEDs may be used in matrix displays in natural-emission colors, provided color coding is not required. Red LEDs should be used in transilluminated displays in crew stations exposed to ambient illumination of direct sunlight, but LEDs used in alphanumeric displays and green and yellow LEDs should not be used without approval of the acquiring activity.

MIL-HDBK-759B

5.2.2.6.2.3.2.3 Intensity control. The dimming of LEDs should be compatible with the dimming of incandescent lamps.

5.2.2.6.2.3.2.4 Lamp testing. LED indicator lights with 100,000 hours mean time between failure (MTBF) should not require the lamp test capability specified in MIL-STD-1472.

5.2.2.6.2.3.3 Dot matrix displays/segmented displays.

5.2.2.6.2.3.3.1 General. The design criteria listed below should be applied to those displays (light-emitting diodes, CRT, and gas discharge) used for the presentation of alphanumeric and symbolic information.

5.2.2.6.2.3.3.2 Application. Dot matrix displays may be used for applications involving interactive computer systems since they are capable of providing capacious information interface within the personnel-computer system. Dot matrix displays may also be used in instruments, avionics, navigation and communication equipment where the presentation of alphanumeric, vector-graphic, symbolic, or real-time information is required.

5.2.2.6.2.3.3.3 Symbol definition. The smallest definition for a dot mosaic should be 5-by-7, with 7-by-9 preferred. If system criteria call for symbol rotation, a minimum definition of 8-by-11 is advisable, and 15-by-21 preferred.

5.2.2.6.2.3.3.4 Symbol subtense. Alphanumeric characters should subtend not less than 16 minutes of visual angle. Flight display alphanumerics should subtend not less than 24 minutes of visual angle to ensure adequate legibility under aircraft environmental conditions.

5.2.2.6.2.3.3.5 Viewing angle. The optimum angle for viewing a dot matrix display is perpendicular to the display. No viewer should be required to view a dot matrix display at an angle larger than 45° off-axis.

5.2.2.6.2.3.3.6 Emitter color. Monochromatic matrix displays should use the following colors, in order of preference: green (555nm), yellow (575nm), orange (585 nm), and red (660 nm). Blue emitters should be avoided.

5.2.2.6.2.3.4 Electroluminescent displays.

5.2.2.6.2.3.4.1 Applications. Electroluminescent displays may be used wherever system criteria dictate the use of transilluminated displays. In addition, they may replace existing mechanical instrumentation while offering advantages of lighter weight, conservation of panel space, lower power criteria, lack of heat production, uniform distribution of illumination, longer life, elimination of parallax, and flexibility of display. Electroluminescent displays may also be used where sudden lamp failure could result in catastrophic consequences.

5.2.2.6.2.3.4.2 Alphanumeric character and symbol sizes. Alphanumeric characters and geometric and pictorial symbols should subtend not less than 15

MIL-HDBK-759B

minutes of visual angle. Alphanumeric characters should be composed of upper case letters. Flight display alphanumerics should subtend not less than 24 minutes of visual angle to ensure adequate legibility under aircraft environmental conditions.

5.2.2.6.2.4 Mechanical flags.

5.2.2.6.2.4.1 Application. Flags should be used to display qualitative, non-emergency conditions.

5.2.2.6.2.4.2 Mounting. Where practical, flags should be mounted inside the instrument cover glass as close to the display surface as is practical without restricting flag movement. The flag in its stowed position should not obscure necessary information on the primary display. However, where practicable the flag, when in the no-go position, should extend into the display area (and preferably obscure some displayed element) far enough to ensure that the operator will take note of the condition indicated by the flag (display or instrument inoperative).

5.2.2.6.2.4.3 Snap action. Flags should operate by snap action.

5.2.2.6.2.4.4 Contrast. A minimum of 75% contrast should be provided between flags and their backgrounds under all expected lighting conditions.

5.2.2.6.2.4.5 Legend. When a legend is provided on the flag, lettering should appear upright when the flag assumes the active or no-go position.

5.2.2.6.2.4.6 Test provision. A convenient means should be provided for testing the operation of flags.

5.2.2.6.2.5 Plotters and recorders.

5.2.2.6.2.5.1 Visibility. Critical graphics (points, curves, and grids that need to be observed during the time that the recording is being made) should not be obscured by pen assembly, arm or other hardware elements.

5.2.2.6.2.5.2 Contrast. A minimum of 50% contrast should be provided between the plotted function and the background on which it is drawn.

5.2.2.6.2.5.3 Take-up device. A take-up device for extruded plotting material should be provided when necessary or desirable.

5.2.2.6.2.5.4 Job aids. Graphic overlays should be provided where these may be critical to proper interpretation of graphic data as it is being generated. Such aids should not obscure or distort the data.

5.2.2.6.2.5.5 Annotation. Where applicable, plotters should be designed and/or mounted so that the operator can manually write on or mark on the plotting paper while it is still in the plotter.

MIL-HDBK-759B

5.2.2.6.2.5.6 Control, replenishment, and service. Plotters and recorders should be designed to conform to criteria herein, with regard to:

- a. controls/displays used to start, stop, or adjust the machine and critical operating elements,
- b. insertion, adjustment for operation, removal of paper, replenishment of ink supply, replacement of pen or other items determined to be operator tasks,
- c. minor servicing on site by a technician, such as adjustment of drive system, cleaning, or replacement of operating items that ordinarily would not be available to an operator, and
- d. positive indication of the remaining supply of plotting materials (paper, ink, and ribbon).

5.2.2.6.2.5.7 Smudging/Smearing. The plot should be resistant to smudging or smearing under operational use.

5.2.2.6.2.6 Printers. Criteria in 5.2.2.6.2.5 should apply to printers as applicable. In addition, the printer should be free from character line misregistration, and character tilt or smear. The printer also should not be excessively noisy if it will be located in an area normally occupied by personnel for more than a few minutes, or where critical direct or telephone conversations are required.

5.2.2.6.2.6.1 General. These guidelines for printers deal primarily with the printout or hard copy such devices produce.

5.2.2.6.2.6.2 Lettering. Lettering should be black on white paper to provide maximum contrast.

5.2.2.6.2.6.3 Paper. Hard-finish matte paper should be used to avoid smudged record research is required, accordion-fold paper should be used.

5.2.2.6.2.6.4 Features. Printers should have the features shown below:

- a. A paper advance control should be provided where necessary so the operator can read the most recently printed line.
- b. A cutting edge should be provided to remove printed material rapidly and evenly.
- c. There should be an indication of the paper supply remaining.
- d. There should be some provision for taking up finished copy.
- e. Papers retainers should be provided to reduce paper vibration.

MIL-HDBK-759B

5.2.2.6.2.6.5 Loading/reloading. Provision should be made for loading paper, ribbon, or ink without extensive disassembly or using special tools. Instructions for reloading should appear on an instruction plate attached to the printer. In addition, storage should be provided for supplies such as ribbons, spare paper, and ink.

5.2.2.6.2.6.6 Optical projection displays.

5.2.2.6.2.6.6.1 Application. Providing ambient light can be properly controlled, optical projection displays are suitable for applications requiring group presentation, pictorial and spatial information, past history vs real-time presentation, synthetically generated pictures, simulation of the external world and superposition of data from more than one source. Rear projection should be used where physical obstructions to front projection result in poor visibility or where work areas require high ambient illumination for other activities.

5.2.2.6.2.6.6.2 Seating area. Optical projection displays for group viewing should be designed such that viewing distance/image width relationship and off-centerline viewing should conform to the preferred limits of Table 24 and should not exceed the acceptable limits indicated. For individual viewing from a fixed location, off-centerline viewing should not exceed 100.

5.2.2.6.2.6.6.3 Image luminance and light distribution. Image luminance and light distribution should conform to the preferred limits and should not exceed the acceptable limits of Table 24. In any case, the luminance of the screen center at the maximum viewing angle should be at least half its maximum luminance.

5.2.2.6.2.6.6.4. Legibility of projected data.

5.2.2.6.2.6.6.4.1 Style. A simple style of numerals and letters should be used. Capital letters should be used, rather than lower case, except for extended copy of lengthy messages. Stroke width should be 1/6 to 1/8 of numeral or letter height; however, stroke width may be narrower for light markings on a dark background. Letter and numeral widths, character spacing and word spacing should conform to criteria in 5.5.

5.2.2.6.2.6.6.4.2 Size. The height of letters and numerals (except single stroke characters, such as the numeral "1") should not be less than 10 minutes of visual angle and, preferably, not less than 15 minutes as measured from the longest anticipated viewing distance.

5.2.2.6.2.6.6.4.3 Contrast. Characters may be either dark on light background or vice-versa, except where superposition is used. Colored markings against colored backgrounds of comparable brightness should be avoided.

5.2.2.6.2.6.6.4.4 Alignment. Misregistration of superimposed alphanumeric data or other symbols should be minimized.

MIL-HDBK-759B

TABLE 24. Group viewing of optical projection displays

FACTOR	OPTIMUM	PREFERRED LIMITS	ACCEPTABLE LIMITS
Ratio of <u>viewing distance</u> screen diagonal	4	3-6	2-8
Angle off centerline	0°	20°	30°
* Image luminance (no film in operating projector)	34 cd/m ²	27-48 cd/m ²	17-69 cd/m ²
Luminance variation across screen (ratio of maximum to minimum luminance)	1	1.5	3.0
Luminance variation as a function of viewing location (ratio of maximum to minimum luminance)	1	2.0	4.0
Ratio of <u>ambient light</u> brightest part of image	0	0.002-0.01	0.1 max ^{**}

* For still projections higher values may be used.

** For presentations not involving gray scale of color (line drawings, tables) 0.2 may be used.

5.2.2.6.2.6.64.5 Keystone effects. Projector-screen arrangement should be considered to minimize "keystone effects," such as distortion of projected data proportions resulting from non-perpendicularity between projector and screen.

5.2.2.7 Speech input and audio displays.

5.2.2.7.1 General. Speech input is received through microphones for processing and transmission through voice communication systems or for entry to speech recognition systems. Audio displays are used not only to present voice

MIL-HDBK-759B

communication from another source but also to present sonically-derived sensor data, synthetic speech, alerting and cueing signals, and other acoustically-coded information. Unlike vision, which can be interrupted by eyelid closure, auditory input is constant. The perception of visual and auditory stimuli is influenced by the ability of the human brain to integrate this input. Vision integrates spatial contrast border, brightness and color information while audition integrates sound pattern, dynamics, and frequency information. Visual and auditory integration times vary and depend upon several stimulus parameters but are normally short. These differences and others discussed in this section should be considered in planning and designing systems utilizing speech or other acoustic signals.

5.2.2.7.1.1 Comparative characteristics of audio signals. For the purposes of this handbook audio signals will be considered to be of three basic types: tones, complex sound, and speech. A comparison of the strengths and weaknesses of these types with respect to their use for various functions is presented in Table 25.

5.2.2.7.2.2 Application.

5.2.2.7.1.2.1 Voice Communication. Voice communication should be considered for systems in the situations listed below.

- a. The message content or format cannot be predicted in advance.
- b. Considerable and/or rapid interaction between operators will be required as where there should be joint solution of a war problem, or where it is necessary to "break into" concurrent information transmission.
- c. The voice signal itself offers assurance of essential psychological support not otherwise available.
- d. Users cannot conveniently look at a visual display to obtain information.

5.2.2.7.1.2.2 Individual speaker recognition. Automatic speaker recognition techniques may be employed in systems to positively identify an originator to an addressee or to restrict communication access to specific individuals (to limit access to a data bank). If individual speaker recognition is used for security purposes (to deny access to classified material by unauthorized personnel), it should be used in combination with some other control method in order to attain sufficient reliability.

MIL-HDBK-759B

TABLE 25. Functional evaluation of audio signals

FUNCTION	TYPE OF SIGNAL		SPEECH
	TONES (Periodic)	COMPLEX SOUNDS (Non-Periodic)	
QUANTITATIVE INDICATION	<u>POOR</u> Maximum of 5 to 6 tones absolutely recognizable.	<u>POOR</u> Interpolation between signals inaccurate.	<u>GOOD</u> Minimum time and error in obtaining exact value in terms compatible with response.
QUALITATIVE INDICATION	<u>POOR-TO-FAIR</u> Difficult to judge approximate value and direction of deviation from null setting unless presented in close temporal sequence.	<u>POOR</u> Difficult to judge approximate deviation from desired value.	<u>GOOD</u> Information concerning displacement, direction, and rate presented in form compatible with required response.
STATUS INDICATION	<u>GOOD</u> Start and stop timing. Continuous information where rate of change of input is low	<u>GOOD</u> Especially suitable for irregularly occurring signals (e.g., alarm signals).	<u>POOR</u> Inefficient; more easily masked; problem of repeatability.
TRACKING	<u>FAIR</u> Null position easily monitored; problem of signal-response compatibility.	<u>POOR</u> Required qualitative indications difficult to provide.	<u>GOOD</u> Meaning intrinsic in signal.
GENERAL	Good for automatic communication of limited information. Meaning must be learned. Easily generated.	Some sounds available with common meaning (e.g., fire bell). Easily generated.	Most effective for rapid (but not automatic) communication of complex, multidimensional information. Meaning intrinsic in signal and context when standardized. Minimum of new learning required.

MIL-HDBK-759B

5.2.2.7.1.2.3 Speech recognition for information retrieval and computer control.

Automatic speech recognition systems which are used to recognize the spoken words but not the individual speaker provide an alternate to keysetting techniques for information retrieval and computer control. However, because of the possible misapplication of automatic speech recognition, such techniques should be considered for use only when:

- a. the vocabulary needed at each phase of operation is comparatively small, (vocabulary criteria can be considerably reduced by using syntax control which limits the necessary vocabulary search to the words which are plausible at that particular point in the entry sequence).
- b. error rates would be comparable to or more favorable than those with other types of control input such as keysets,
- c. speed of entry would be equal to or faster than conventional entry techniques,
- d. convenient means of error detection and correction are provided,
- e. convenient means are provided to inhibit the system except when speech input is intended, and
- f. performance will be satisfactory even under stress conditions.

5.2.2.7.1.2.4 Audio displays. Audio displays are necessary when amplified signals are used in voice communication. They should also be considered under the conditions listed below.

- a. The information that is to be processed is short, simple, and transitory, requiring an immediate or time-based response.
- b. The visual display is restricted by: overburdening, ambient light variability or limitation; operator mobility; degradation of vision by reason of vibration, high-g forces, hypoxia; other environmental considerations; or anticipated operator inattention.
- c. The critical nature of transmission response makes supplementary or redundant transmission desirable.
- d. It is desirable to capture the operator's attention for advisory, cueing, alerting, or warning purposes.
- e. Custom or usage has created anticipation of an audio display.
- f. An auditory presentation is desirable to reinforce a visual presentation.

5.2.2.7.1.2.5 Aircrew stations. Audio signals for aircrew stations should conform to MIL-STD-411, as applicable.

MIL-HDBK-759B

5.2.2 .7.1.2.6 Sensor applications. Audio displays for sensor systems such as sonar and electronic countermeasures should be made compatible with the criteria stated herein. Deviations should require approval of acquiring activity.

5.2.2 .7.1.3 Circuit test. All audio displays should be equipped with circuitry test devices or other means of testing operability.

5.2.2.7.2 Non-verbal audio signals for advisory, cueing, alerting and warning functions.

5.2.2 .7.2.1 General. Audio signals should be provided as necessary to warn personnel of impending danger, to alert operators to a critical change in system or equipment status, to remind operators of a critical action or actions that should be taken, or to advise personnel of some change in system state or data.

5.2.2 .7.2.1.1 Frequency range. The frequency range should be between 200 and 5,000 Hz and, if possible, between 500 and 3,000 Hz. When signals should travel over 300 m, sounds with frequencies below 1,000 Hz should be used. Frequencies below 500 Hz should be used when signals should bend around obstacles or pass through partitions. To the extent possible the selected frequency band should differ from the most intense background frequencies and should be in accordance with other criteria in this section.

5.2.2 .7.2.1.2 Avoidance of power frequencies. In order to avoid possible confusion between power frequencies emitted by malfunctioning power circuits and meaningful audio signals, the signal frequencies should always be different from the power frequencies.

5.2.2.7.2.1.3 Compatibility with acoustical environment. The intensity, duration, and source location of audio signals should be selected so as to be compatible environmentally with all personnel in the signal areas as well as with the specific individuals intended to receive the signals. Except when essential for safety, signal level should not be so high as to cause discomfort or ringing in the ears.

5.2.2.7.2.1.4. Compatibility with clothing and equipment. As applicable, audio signals should be loud enough to be heard and understood through equipment or garments (parka hood, NBC protective hood, and hearing protective devices covering the ears of the listener).

5.2.2.7.2.1.5 Use of different characteristics. When several different audio signals are to be used concurrently, discriminable differences in spectral composition and/or temporal pattern should be provided. When specific recognition of individual signals is important, their differences should be coded in a simple and easily recognized way.

MIL-HDBK-759B

5.2.2.7.2.1.6 Prohibited types of signals. The types of signals listed below should not be used where possible confusion might exist because of the operational environment.

- a. Modulated or interrupted tones that resemble navigation signals or coded radio transmissions.
- b. Steady signals that resemble hisses, static, or sporadic radio signals.
- c. Trains of impulses that resemble electrical interference whether regularly or irregularly spaced in time.
- d. Simple warbles which may be confused with the type made by two carriers when one is being shifted in frequency (beat-frequency-oscillator effect).
- e. Signals that resemble random noise, periodic pulses, steady or frequency modulated simple tones, or any other signals generated by standard countermeasure devices ("bagpipes").
- f. Signals similar to random noise generated by air conditioning or any other equipment.
- g. Signals that resemble sounds likely to occur accidentally under operational conditions.

5.2.2.7.2.2 Advisory signals. Audio signals may be provided to transmit information of an advisory nature which does not require specific operator response or acknowledgement. In quiet areas advisory signals should be presented at a level of 50 to 70 dB on the A-weighted scale. Where there is a noise background they should be at least 20 dB above the noise level in the critical band centered on each major component frequency of the advisory signal.

5.2.2.7.2.3 Cueing signals. Audio cueing signals should be provided for pacing operator actions in situations requiring timely execution of task elements but where: (1) operator attention may be diverted from the task at hand, or (2) the operator depends on the cueing signal to know when to perform the task. Cueing signals may be used in combination with visually-presented messages providing specific task element instructions. Cueing signals should be short, tonal, and non-annoying but distinctive in character, and as a general rule should exceed the noise level in the critical band by at least 20 dB. Consideration should be given to instrumenting the cueing signal system so as to generate a repetition of the signal if the operator fails to perform the desired action.

5.2.2.7.2.4 Alerting signals. Alerting signals should be provided whenever there is a requirement for immediate response to a situation outside of the operator's normal task sequence, such as when there is incoming traffic on an unattended circuit, or some system function needs attention on an irregular basis, or there may be a minor component failure. Alerting signals should be of a spectral composition and character more demanding of attention than either advisory or cueing signals. They may be

MIL-HDBK-759B

momentary or continuous in nature as appropriate, but if momentary they should be repeated periodically until either proper action is taken or the signal is turned off. Similarly, continuously-presented alerting signals should persist until initiation of proper action or signal turn-off, After the signal is terminated it should be automatically reset to respond to the next initiating condition. As a general rule, alerting signals should exceed the noise level in the critical band for all major signal components by at least 20 dB.

5.2.2.7.2.4.1 Differentiation from routine signals. Alerting signals intended to bring the operator's attention to a malfunction or failure should be differentiated from routine signals such as bells, buzzers, and normal operation noises.

5.2.2.7.2.5 Caution signals. Caution signals should be used to capture the attention of personnel so as to direct them to potentially destructive conditions requiring immediate awareness. (There is not immediate threat to life or major property damage, but there may be incipient threat to either, or there may be a possible threat to major system malfunction or abort.) They may provide either one or two functions. A single-function caution signal consists of an alert only and should be accompanied by a visually-presented message identifying the specific nature of the caution situation. Two-function caution signals which provide both the alerting and identification functions should be used where the total number of caution signals is small. Caution signals should consist of distinctive complex sounds at least 20 dB on the A-weighted scale above the noise environment. They should persist intermittently until restoration of normal conditions or manual shut off. Upon termination, they should be automatically reset to respond to the next initiating condition. A volume control may be incorporated provided full volume is automatically restored upon initiation of the next caution signal.

5.2.2.7.2.6 Warning signals. Warning signals should be used to alert personnel of immediate action required in hazardous or emergency situations. These signals should alert personnel and transmit identifying or action signals. These functions may be accommodated by either a two-element or single-element signal as appropriate to the situation in consideration of the total acoustic signal environment. Ordinarily if a small set of warning signals is used, the single-element signal would be preferred since this would provide the shortest reaction time. Warning signals should consist of distinctive complex sounds of exceptional attention-getting value and be presented at a level of at least 20 dB (on the A-weighted scale) above the noise environment. Examples of warning signals include fire alarms, collision alarms, and transit bells on cranes.

5.2.2.7.2.6.1 Warning recognition. Warning signals should be sufficiently distinctive so that they can be unambiguously recognized as warning signals within 0.5 seconds of initiation. Single-element signals should, in addition, convey full meaning of the signal within that initial 0.5 second period. In the worst case, two-element signals should convey full meaning of the signal within 2.5 seconds of initiation.

MIL-HDBK-759B

5.2.2.7.2.6.2 Control of warning signals. Warning signals may be either manually or automatically initiated, whichever is more appropriate to the circumstances. Manually initiated signals should also be manually terminated. Automatically initiated signals should persist until either automatically or manually terminated. Automatic termination should not be on a time basis but rather on either initiation of action to restore normal conditions or upon restoration of normal conditions. Provision for manual termination should always be provided. Automatic reset for the next initiating condition should be provided for all signals which can be automatically initiated. Local area volume control (with volume reduction limited to ensure signal audibility) may be incorporated provided full volume is automatically restored upon initiation of the next warning signal.

5.2.2.7.2.6.3 Compatibility with existing signal codes. Warning signal characteristics and meanings selected for a system or facility should be compatible with signals already established for the particular warning situation.

5.2.2.7.2.6.4 Compatibility with other critical signals. No warning signal should be of such a character as to preclude hearing any other warning signal or reception of vital voice communication.

5.2.2.7.2.6.5 Operation with headsets. Operators who normally wear earphones covering both ears should have the warning signal presented in the headset as well as in the work area. When feasible a dichotic presentation should be used to present the warning signal to one ear and the normal auditory signals to the other ear, and preferably to alternate the signals between ears.

5.2.2.7.3 Voice communication.

5.2.2.7.3.1 Verbal caution and warning signals. Verbal caution signals should be made as standardized as possible. They may be used in connection with an initial non-speech alerting signal. Verbal warning signals should always be preceded by an initial alerting signal (non-speech) to attract attention and to designate the general problem. The verbal part of the warning signal should consist of a brief standardized speech signal (verbal message) which identifies the specific condition and appropriate action.

5.2.2.7.3.1.1 Intensity. Verbal signals for caution conditions should be at least 10 dB above the noise level at the operating position of the intended receiver, and verbal warnings should be at least 20 dB above the noise level. (All readings on the A-weighted scale.)

5.2.2.7.3.1.2 Voice criteria for recorded caution and warning messages. The voice used in recording verbal messages should be clear in enunciation, free from regional dialects, authoritative, confident, and sound concerned but not detached or anxious. Delivery should be brisk but unhurried.

5.2.2.7.3.1.3 Speech processing of caution and warning messages. Verbal caution and warning messages should be processed only when necessary to increase or preserve intelligibility, such as by increasing the strength of consonant sounds

MIL-HDBK-759B

relative to vowel strength. Where a signal should be relatively intense because of high ambient noise, "peak-clipping" may be used to protect the listener against auditory overload.

5.2.2.7.3.1.4 Message content. In selecting words to be used in recorded verbal caution or warning signals, priority should be given to aptness, intelligibility, and conciseness in that order.

5.2.2.7.3.1.5 Repetition of verbal warning. Critical warning signals should be repeated with not more than a three-second pause between messages until the warning state is terminated either automatically or manually.

5.2.2.7.3.1.6 Prioritization. When there could be a possibility of simultaneous presentation of automatically initiated messages, a message priority system should be provided, such that the most critical message overrides for initial presentation any messages occurring lower on the priority list. Following initial presentation of the top priority message, other messages should be presented in the priority order, except that no caution messages should be presented until all warning messages are terminated.

5.2.2.7.3.2 Voice communication equipment.

5.2.2.7.3.2.1 Telephone or radio communications. Design of military integrated telephone or radio communication systems, either of a switched or point-to-point nature, should be in accordance with the applicable requirements of MIL-STD-188.

5.2.2.7.3.2.2 Microphones and speech input equipment.

5.2.2.7.3.2.2.1 Frequency. Microphones and associated system-input devices should be designed to respond optimally to that part of the speech spectrum most essential to intelligibility (200 to 6,100 Hz) except where system engineering requires speech transmission bandwidths substantially narrower. The minimum acceptable frequency range should be 250 to 4,000 Hz. In these cases the speech input equipment should be compatible with the transmission bandwidth being used.

5.2.2.7.3.2.2.2 Dynamic range. The dynamic range of a microphone and its associated amplifier should be great enough to admit variations in signal input of at least 50 dB.

5.2.2.7.3.2.2.3 Noise-cancelling microphones. In very loud, low-frequency noise environments (100 dB or over), noise-cancelling microphones should be used and should be capable of effecting an improvement of not less than 10 dB in peak-speech to root-mean-square-noise ratio as compared with non-noise-cancelling microphones of equivalent transmission characteristics.

5.2.2.7.3.2.2.4 Pre-emphasis. If necessary, speech system-input devices may employ frequency pre-emphasis with a positive slope frequency characteristic no greater than 18 dB per octave from 140 to 1,500 Hz and no greater than 9 dB per octave over the frequency range 1,500 to 4,800 Hz, when no clipping is used.

MIL-HDBK-759B

5.2.2.7.3.2.2.5 Peak-clipping of speech signals. Where speech signals are to be transmitted over channels showing less than 15 dB in peak-speech to root-mean-square-noise ratios, peak-clipping of 12 to 20 dB may be employed at the system input and may be preceded by frequency pre-emphasis as specified in 5.2.2.7.3.2.2.4.

5.2.2.7.3.2.2.6 Noise shields. When the talker is in an intense noise field, the microphone should be put in a noise shield. Noise shields should be designed to meet the criteria listed below.

- a. A volume of at least 250 cm³ to permit a pressure gradient microphone to function normally.
- b. A good seal against the face with the pressure of the hand or the tension of straps.
- c. A hole or combination of holes covering a total area of 65 mm² in the shield to prevent pressure buildup.
- d. Prevention of a standing wave pattern, which can produce frequency or phase distortion, by shape, or by use of sound absorbing material.
- e. No impediment to voice effort, mouth, or jaw movement or breathing.

5.2.2.7.3.2.3 Headphones and loudspeakers.

5.2.2.7.3.2.3.1 Frequency response. Headphones and loudspeakers should be subject to the same frequency response restrictions as microphones and transmission equipment except that loudspeakers for use in multi-speaker installations (where several speech channels are to be monitored simultaneously) should respond uniformly (+/-5 dB) over the range 100 to 4,800 Hz.

5.2.2.7.3.2.3.2 Loudspeakers for multi-channel monitoring.

- a. Mounting of speakers. If separate speakers on different channels are to be monitored simultaneously, the speakers should be mounted so that they are not less than 10° apart in the horizontal plane frontal quadrant, ranging radially from 45° left to 45° right of the operator's normal forward facing position. "Channel-busy" lights should be provided to show channel utilization.
- b. Filtering. When additional channel differentiation is required, apparent lateral separation may be enhanced by applying low-pass filtering (frequency cutoff, $F_c = 1,800$ Hz) to signals fed to loudspeakers on one side of the central operator position. If there are three channels, one channel should be left unfiltered, a high-pass filter with 1,000 Hz cutoff should be provided in the second channel, and a low-pass filter with 2,500 Hz cutoff should be provided in the third channel. "Channel-busy" lights should be provided to show channel utilization.

MIL-HDBK-759B

5.2.2.7.3.2.4 Use of de-emphasis. If transmission equipment employs pre-emphasis and peak-clipping is not used, reception equipment should employ frequency de-emphasis of characteristics complementary to those of pre-emphasis only if it improves intelligibility (de-emphasis should be a negative-slope frequency response not greater than 9 dB per octave over the frequency range 140 to 4,800 Hz).

5.2.2.7.3.2.5 Headsets. If listeners will be working in high ambient noise (85 dB(A) or above), binaural rather than monaural headsets should be provided. Unless operational criteria dictate otherwise, binaural headsets should be wired so that the sound reaches the two ears in opposing phases. Their attenuation qualities should be capable of reducing the ambient noise level to less than 85 dB on the A-weighted scale for all users including those who wear glasses.

5.2.2.7.3.2.5.1 Speaker side tone. If headsets are used, feedback of the speaker's own voice (side tone) should be provided via the earphones. The side tone should not be filtered or modified before it is displayed, and it should be in phase with the speech signal.

5.2.2.7.3.2.6 Operating controls for voice communication equipment.

5.2.2.7.3.2.6.1 Volume controls. Accessible volume or gain controls should be provided for each communication receiving channel (loudspeakers or headphones) with sufficient range to drive sound pressure level to at least 110 dB overall when using two earphones. (Unpressurized aircraft should be equipped with pressure operated gain control switches to compensate for altitude changes.) The minimum setting of the volume control should be limited to an audible level. It should not be possible to inadvertently disable the system with the volume control. While separation of power (on-off) and volume control adjustment functions into separate controls is preferred, if conditions justify their combination, a noticeable detent position should be provided between the OFF position and the lower end of the continuous range of volume adjustment.

5.2.2.7.3.2.6.2 Squelch control. Where communication channels are to be continuously monitored, each channel should be provided with a signal-activated switching device (squelch control) to suppress channel noise during no-signal periods. A manually operated, on-off switch, to deactivate the squelch when receiving weak signals, should be provided.

5.2.2.7.3.2.6.3 Hands-free operation. For situations in which operators using microphones and/or headsets also have both hands occupied most of the time, consideration should be given to providing hands-free operation of microphone and headset switching through use of foot switches, voice-actuated switches, or remotely controlled switches as appropriate to the circuits in use. If there may be any requirement to operate the microphone and/or headset switching from a standing position, then hand-operated switches should also be provided.

MIL-HDBK-759B

5.2.2.7.3.2.7 Comfort and accessibility.

5.2.2.7.3.2.7.1 Comfort. Communication equipment to be worn by an operator (headphones and telephone headsets) should be designed to preclude operator discomfort. Metal parts of the headset should not come in contact with the user's skin. Materials selected should be impervious to biological organisms such as molds and fungi and should not deteriorate from humidity or perspiration.

5.2.2.7.3.2.7.2 Accessibility of handsets. Where communication criteria necessitate the use of several telephone handsets, the accessibility of their standby locations should be determined by operational priority. (The most frequently or urgently needed handset should be the most accessible.) Color coding may also be employed where operating personnel will have visual contact with handsets under the working conditions.

5.2.3 Consoles.5.2.3.1 Standard console design.

5.2.3.1.1 Dimensions. For purposes of standardization, consoles and the units and racks which constitute operator workstations should be designed to conform with the dimensions shown in Table 26 and Figure 37.

5.2.3.1.2 Configurations. The configurations represented in Table 26 and Figure 37 may not be applicable to all design situations. In some cases, however, operational criteria may necessitate unique design solutions. Because of the benefits and economies inherent in a standard console and unit, the design should conform with the standard configurations whenever feasible.

5.2.3.1.3 Desire and layout. The effectiveness with which the operator performs tasks will depend upon: designing the contours and slopes of the console or instrument panel to minimize parallax in viewing displays, locating controls so they can be easily manipulated, and providing adequate space and supports for the operator.

MIL-HDBK-759B

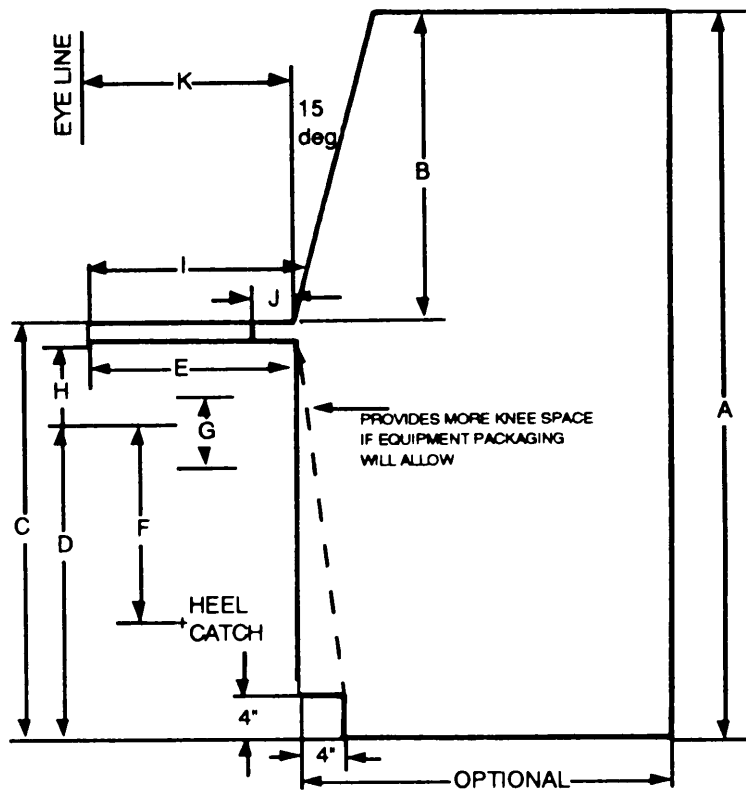

Key	Dimensions	mm
A	Maximum total console height from standing surface	*
B	Suggested vertical dimension of panel, including sills	*
C	Writing surface: shelf height from standing surface	*
D	Seat height from standing surface at midpoint of "G"	*
E**	Minimum knee clearance	460
F**	Foot support to sitting surface***	460
G**	Seat adjustability	150
H**	Minimum thigh clearance at midpoint of "G"	190
I	Writing surface depth including shelf	400
J	Minimum shelf depth	100
K	Eye line-to-console front distance	400

* See Table 26.

* Not applicable to console types 4 and 5 of Table 26.

** Since this dimension should not be exceeded, a heel catch should be added to the chair if "D" exceeds 460 mm.

NOTE: If the console is to be used by male personnel exclusively, change G to 125 and H to 165.

FIGURE 37. Standard console dimensions key

MIL-HDBK-759B

TABLE 26. Standard console dimensions

TYPE OF CONSOLE	MAXIMUM TOTAL CONSOLE HEIGHT FROM STANDING SURFACE	SUGGESTED VERTICAL DIMENSION OF PANEL (INCLUDING SILLS)	WRITING SURFACE: SHELF HEIGHT FROM STANDING SURFACE	SEATED HEIGHT FROM STANDING SURFACE AT MIDPOINT OF G	MAXIMUM CONSOLE WIDTH (NOT SHOWN)
1. SIT (W/VISION OVER TOP)*	A 1.170 m** 1.375 m** 1.435 m**	B 520 m** 520 m** 520 m**	C 650 mm 810 mm 910 mm	D 435 mm 595 mm 695 mm	1.120 m 1.120 m 1.120 m
2. SIT (W/O VISION OVER TOP)	1.310 m 1.470 m 1.570 m	660 mm 660 mm 660 mm	650 mm 810 mm 910 mm	435 mm 595 mm 695 mm	910 mm 910 mm 910 mm
3. SIT-STAND (W/STANDING VISION OVER TOP)	1.535 m**	620 mm	910 mm	695 mm	910 mm
4. STAND (W/VISION OVER TOP)	1.535 m**	620 mm	910 mm	N/A	1.120 m
5. STAND (W/O VISION OVER TOP)	1.830 m	910 mm	910 mm	N/A	910 mm

* THE RANGE IN "A" IS PROVIDED TO ALLOW LATITUDE IN THE VOLUME OF THE LOWER PART OF THE CONSOLE; NOTE RELATIONSHIP TO "C" AND "D".

** IF THE CONSOLE IS TO BE USED EXCLUSIVELY BY MALE PERSONNEL, THE ABOVE VALUES ARE CHANGED AS FOLLOWS:

A1: 1.210 m
A3: 1.570 m
A4: 1.570 m
B1: 560 mm
560 mm
560 mm

MIL-HDBK-759B

5.2.3.2 Special-purpose console design.5.2.3.2.1 Horizontal wrap-around (see Figure 38).

5.2.3.2.1.1 Panel width. When criteria for preferred panel space for a single seated operator exceed a panel width of 1.12 m, a flat-surface, segmented, wrap-around console should be provided so as to place all controls within the reach of the 5th percentile stationary operator.

5.2.3.2.1.2 Panel angle. The left and right segments should be placed at an angle, and measured from the frontal plane of the central segment, such that they can be reached by the 5th percentile stationary operator.

5.2.3.2.1.3 Dimensions (vision over top). Where vision over the top is required (thereby limiting vertical panel space), the width of the central segment should not exceed 1.12 m, and that of the left and right segments should not exceed 610 mm.

5.2.3.2.1.4 Dimensions. Where vision over the top is not required, such as when the total console height may exceed the seat height by more than 685 mm, the width of the central segment should not exceed 860 mm, and that of the left and right segments should not exceed 610 mm.

5.2.3.2.1.5 Viewing angle. The total required left-to-right viewing angle should not exceed 190° (see Figure 26). This angle should be reduced whenever possible through appropriate control/display layout.

5.2.3.2.2 Vertical/stacked segments. (see Figure 39).

5.2.3.2.2.1 Panel division. Where direct forward vision over the top of the console is not required by a seated operator, and when lateral space is limited, the panel should be divided into three vertical/stacked segments whose surfaces should be perpendicular to the operator's line of sight with little or no head movement.

5.2.3.2.2.2 Height. The center of the central segment should be 800 mm above the seat reference point. The height of this segment should not exceed 530 mm.

MIL-HDBK-759B

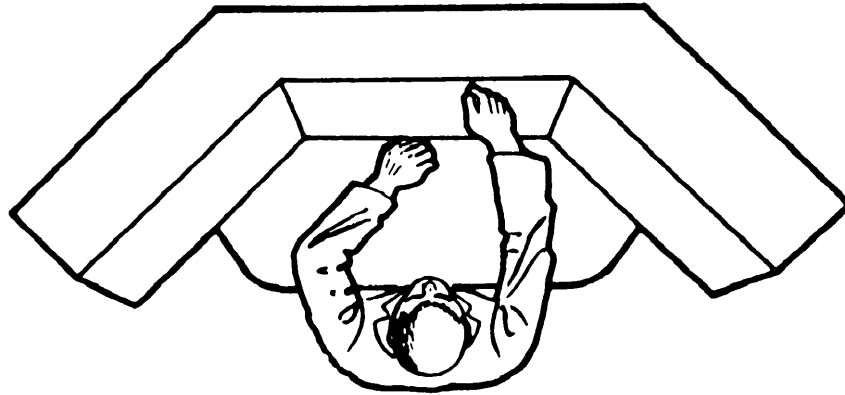

FIGURE 38. Example of wrap-around console

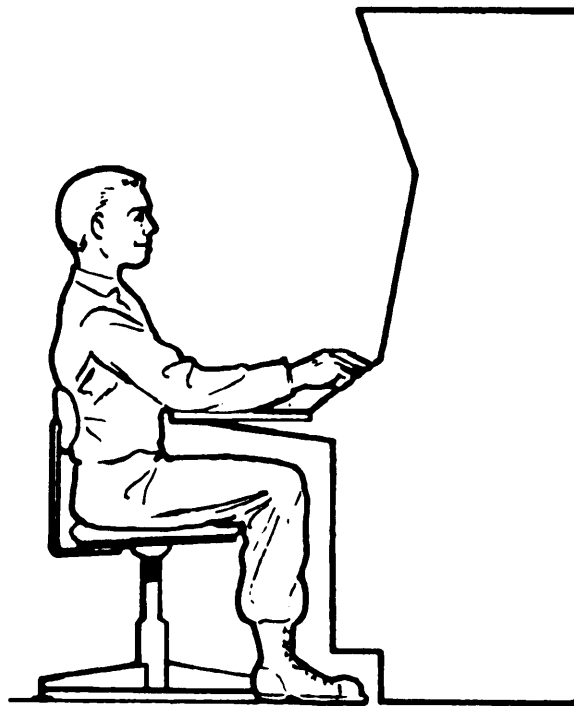

FIGURE 39. Example of vertical/stacked segments

MIL-HDBK-759B

5.2.3.2.3 Sit-stand consoles. Where personnel will work from standing or seated positions, console dimensions should conform to those of Table 26.

5.2.3.3 Display surfaces. The various surfaces on consoles or instrument panels can be classified in terms of primary and secondary display and control areas. Each of these has its own guidelines.

5.2.3.3.1 Primary display surface. The primary visual surface on consoles or instrument panels should be reserved for displays which are used frequently or are critical to successful operation. Special cases, where controls and displays are combined, or control and display compatibility is important (even though the displays are of secondary importance), may warrant placing them on this surface. In general, this area should correspond to the preferred viewing area shown in Figure 26.

5.2.3.3.2 Secondary display surface. The secondary display surfaces are located above or to the side of the primary display surfaces. These surfaces should be used for displays which are used infrequently during operations (set-up, adjustment, or operationally non-critical functions).

5.2.3.3.3 Design principles. The designer should use the principles listed below in laying out displays on the console or instrument panel.

- a. Frequently monitored displays should be within the operator's preferred viewing area (Figure 26).
- b. Indicators that are used for long, uninterrupted periods should be in the preferred position.
- c. The preferred distance to displays is 635 mm.
- d. The viewing distance to displays should not be less than 250-300 mm for short viewing periods, and preferably not less than 400 mm.
- e. Displays requiring accurate readout should be located closer to the operator's line of sight than displays requiring only gross monitoring.
- f. Displays should be mounted perpendicular to the line of sight. Angular deviation from the line of sight (Figure 26) up to 45° may be acceptable, provided accurate instrument reading is not essential and parallax is not too great.
- g. All instruments and legends should be readable from the operator's normal head position, allowing for normal head rotation and for restrictions imposed by helmets or other head gear.
- h. All displays necessary to support an operator activity or sequence of activities should be grouped together.
- i. Infrequently used displays can be in the periphery (maximum viewing angle) of the visual field (Figure 26).

MIL-HDBK-759B

5.2.3.4 Control surfaces. In general, the control area is below the area where displays are mounted; displays which are closely associated with controls can be mounted on these surfaces. The optimum manual space is that in which hand-operated controls can be manipulated with the greatest speed and accuracy (Figure 40). This space is reserved for controls which should be operated frequently or are critical to operations placing controls in the optimum space permitting rapid and accurate identification, reaching and operation, and location of visual displays near the controls.

5.2.3.4.1 Design guides. The designer should use the principles listed below in arranging controls on the console.

- a. Primary controls should be located between shoulder level and waist height.
- b. Controls should be located so that simultaneous operation of two controls will not necessitate crossing or interchanging hands.
- c. When controls are operated frequently, they should be located to the left front or right front of the operator.
- d. Frequently used controls should be grouped together, unless there are overriding reasons for separating them.
- e. Frequently used controls should be located for right-hand operation.
- f. Frequently used controls should be within a radius of 400 mm from the normal working position.
- g. Occasionally used controls should be within a radius of 500 mm.
- h. Infrequently used controls should be within a radius of 700 mm.
- i. Controls should be located where the user can see them to check their positions, regardless of the viewing angle.
- j. All controls should be within the maximum reach of the seated operator (see Figure 40).
- k. Controls requiring fine adjustments should be located closer to the operator's line of sight than controls requiring gross positioning.
- l. When the operator should manipulate controls while monitoring a display, the controls should be placed close to, and directly below, that display.

MIL-HDBK-759B

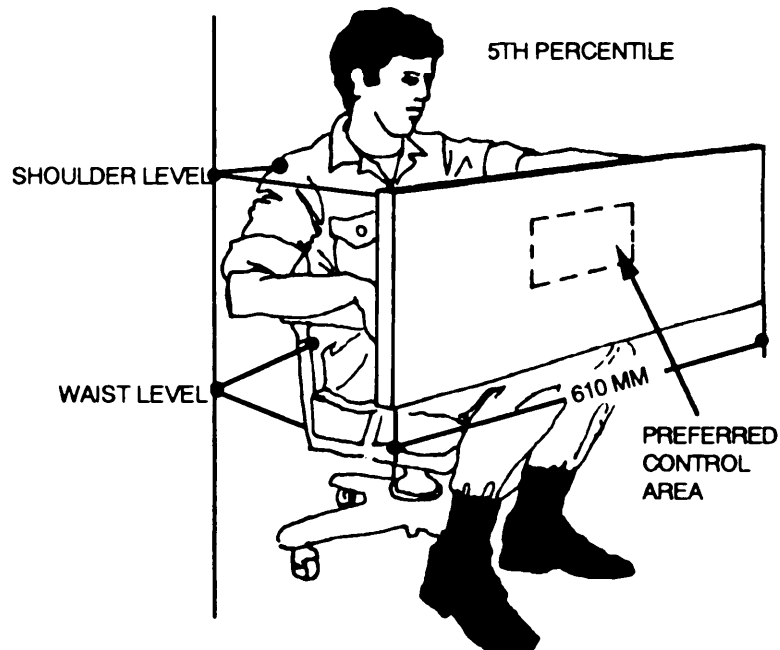
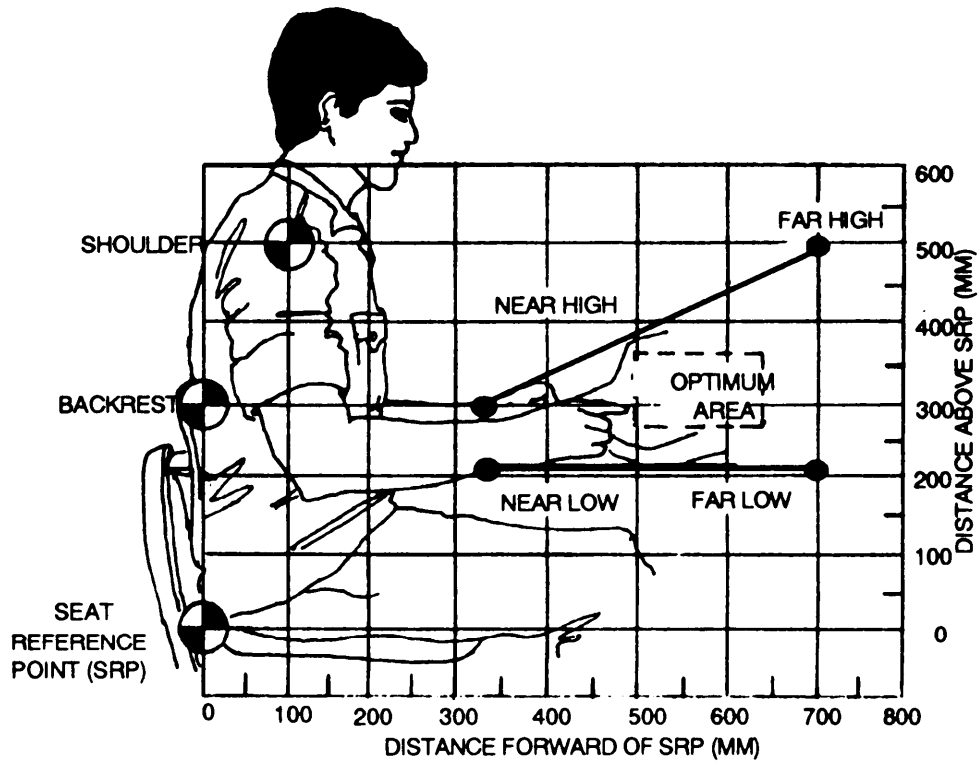

FIGURE 40. Seated optimum manual control space

MIL-HDBK-759B

- m. Controls that are used infrequently should be placed to one side, or even covered, to prevent inadvertent activation.
- n. Occasionally used controls may be mounted behind hinged doors or recessed into the panel to reduce distraction and prevent inadvertent operation. If, because of space constraints, controls should be placed where operators locate them without seeing them, designers should consider these error tendencies:
 - (1) When controls are above shoulder level, operators tend to reach too low.
 - (2) When controls are on either side of the operator, he tends to reach too far to the rear.
 - (3) When controls are placed below shoulder level, operators tend to reach too high. Groups of controls should be arranged so these error tendencies will not cause injury, damage equipment, or allow incorrect operation.

5.2.3.5 Standing operations.

5.2.3.5.1 Work surfaces. A horizontal, or nearly horizontal, work surface which serves primarily as a work or writing surface, or as a support for the operator's convenience items, should be 915 +/- 15 mm above the floor, unless the surface is being used for locating certain types of controls (joystick, track ball, and keyboards) which should be 1.02 to 1.07 m above the floor. Care should be taken, when combining a horizontal workspace and a control panel, to ensure that the operators will have adequate workspace (minimum of 250 mm deep) and that they will be able to reach the control panel (maximum of 400 mm deep).

5.2.3.6 Control/display integration.

5.2.3.6.1 General criteria.

5.2.3.6.1.1 Compatibility. Control/display relationships should be functionally effective and require a minimum of decoding or mental involvement on the part of the operator. This should include relationships between a control and specific display hardware (meters, instruments, and labeled control escutcheon plates), and/or external devices or visual elements that are used as visual references while operating particular controls. A control should not be used in any application in which its movement is likely to be ambiguously interpreted, such as when the manipulation required is opposite to that anticipated or expected by the typical operator.

5.2.3.6.1.2 Physical relationships. The physical relationships of a control to its associated visual display and/or the display to the control should be immediately apparent and unambiguous to the operator. Controls should

MIL-HDBK-759B

normally be placed beneath or to the right of a related display except under conditions listed below.

- a. The display would be obscured by the operator's hand.
- b. Panel space limitations require use of an array of displays that would be selectively operated by means of a "ganged" control device, wherein separate knobs would be associated with individual displays within the array.
- c. The control operation would be inefficient or awkward if the control were placed next to the display, or vice-versa (placement of the display next to the control would make for awkward or inefficient visual access to the display). Typical applications include such relationships as steering wheel, joystick or foot-operated controls relative to displays on an instrument panel.

5.2.3.6.1.3 Organization. Controls and displays should be organized in a manner that will minimize operator effort, confusion, and error, by means of functional grouping, sequential arrangement, accessibility to the nominal user's limb or hand, and/or nominal viewing axis of the operator.

5.2.3.6.1.4 Design detail. Control/display relationships should be apparent through proximity, similarity of groupings, coding, framing, labeling, and similar techniques.

5.2.3.6.1.5 Simplicity. The complexity and/or precision required of control manipulation and display monitoring should be consistent with the precision required of the system and should not exceed the capability of the operator (in terms of discrimination of display detail) and/or exceed the operator's manipulative capability under the dynamic conditions and environment (in terms of manual dexterity, coordination, or reaction time) in which human performance is expected to occur.

5.2.3.6.1.6 Feedback. Control/display systems should be designed to provide feedback on control input and system state as rapidly as possible. Feedback should be considered at the three levels listed below.

a. Control Actuation.

- (1) Discrete state selectors. Controls of this type (toggle switches, push button switches, and rotary selectors) should provide positive indication of control actuation to the operator under all operational conditions. Control displacement sufficient to be unambiguously recognized may provide adequate feedback at this level for most functions.
- (2) Continuous adjustment controls. Controllers such as continuous adjustment knobs, cranks, and joysticks should provide feedback as to where the control is positioned with respect to its entire range of variability. Ordinarily, this is by means of visual indication via the control's moving pointer against a fixed scale.

MIL-HDBK-759B

- b. Transient system response. Feedback at this level is used to provide an indication of system response to the control input between the time of control actuation and that of arriving at system steady-state condition in response to that input. When the transient response is short (less than two seconds duration), feedback at this level is sufficient (there is one clear visual or auditory indication that the system is in the process of responding). However, for especially critical functions, transient system response should be indicated by one of the feedback arrangements listed below.
- (1) Direct positive feedback from the mechanism being driven via, for example, a strong auditory signal directly from a drive motor, or direct visual indication of the orientation of the driven unit.
 - (2) Redundant positive feedback from two different points in the system (a meter indication and a pilot light, which sense the system's transient state).
 - (3) Both positive and negative feedback, so that one or the other will always be activated, whether or not the system responds to the control input, such as when the positive feedback indicates the system is in the process of responding when it should; the negative feedback indicates that the system is not responding when it should; and/or one or the other of the indications would always be present during the transient period.
- c. System steady-state. Feedback should be provided to indicate completion of the system's response to the control input and current system operating state. Usually a single positive feedback indication at this level is sufficient. (The onset of the indication signals completion of the response and the continuing indication constantly informs of system state.) Where the original control input is by some type of discrete state selector, a discrete state indicator for feedback is sufficient. Where the original control input was by a continuous adjustment control, an analog or digital indication of system state is usually required to indicate that the system has responded fully to the control input. Exceptions to this may be allowed where provision is made to automatically compare the completed system response with the magnitude of the control input and to indicate that the system has responded within satisfactory tolerance. For critical functions, a warning indication should be provided to signal at all times following the system transient response when the system state mismatches the ordered state as set by the input control(s).

5.2.3.6.1.7 Illumination. Adjustable illumination should be provided for visual displays including display, control, and panel labels and critical markings that should be read at night or under darkened conditions.

MIL-HDBK-759B

5.2.3.6.2 General arrangement factors. Arrangement of controls and displays at workstations should be in accordance with those arrangement factors most likely to ensure effective operator performance. Care should be exercised to obtain the best balance of these factors when they may be in conflict or may vary in significance with the mode of operation at the workstation.

5.2.3.6.2.1 Operator orientation. Controls and displays associated with a given control/monitoring task(s) should be located and positioned with reference to a specified operator position(s), including criteria for visual monitoring beyond the immediate control/display interface, and should not impose difficult mobility problems for the operator (sitting or standing in an awkward position, frequent extreme reaching and body or head turning criteria, or constant changes in body position in order to accommodate to various control manipulation or visual monitoring tasks).

5.2.3.6.2.2 Dual operation. Where two operators must use the same control or display (when monitoring system status), the criteria listed below should be applied.

- a. If the controls and displays have high priority, duplicate sets should be provided whenever there is adequate space. Otherwise, controls and displays should be centered between the operators.
- b. If secondary controls and displays should be shared, they should be centered between the operators if equally important to each. If the controls or displays are more important to one operator than to the other, they should be placed nearer the operator having the principal criteria for using them.
- c. If the primary or secondary controls must be operated with the user's preferred hand (keyboards, keysenders), duplicate controls should be provided. Such controls should not be centered between the operators.
- d. If direction-of-movement relationships are important, controls and displays should be located so that both operators face in the same direction.

5.2.3.6.3 Functional grouping. Controls and displays should be grouped functionally when they are identical in function, used together in a specific task, and related to one equipment or system component. Once grouped, they should be spatially organized so that the relationship between them is apparent to the operator and all displays used together should be placed at the same viewing distance. In addition, controls and displays should be grouped by function when there is no definite sequence of function.

5.2.3.6.3.1 Sequence of operation. Whenever a frequently recurring sequence of operation (instrument scan or sequential series of control operations) can be defined, control/display elements should be arranged for convenient left-to-right (preferred), or top-to-bottom eye/hand movements, or both. Such sequential arrangement should be observed both for individual items or group-to-group sequences and "within functional groups."

MIL-HDBK-759B

5.2.3.6.4 Sequential grouping. The principles listed below should be applied to displays which are observed in sequence.

- a. When displays are arranged horizontally, they should be viewed from left to right.
- b. When displays are arranged vertically, they should be viewed from top to bottom.
- c. Displays should be grouped, arranged, and located as close together as possible, provided the layout does not make it difficult to interpret individual displays.

When the operator uses several controls in sequence with the same hand, the controls should be arranged in horizontal rows, from left to right, in order of operation. If horizontal rows are impractical, the controls should be arranged in vertical rows, from top to bottom, in order of operation.

5.2.3.6.5 Frequency of use. Controls and/or displays that are used continuously or most frequently should be located and positioned as convenient to the operator as practicable relative to related physical and environmental constraints. Displays should be positioned to minimize excess reaching and/or awkward hand/arm and/or foot/leg movements.

5.2.3.6.6 Importance of use. Controls and displays which are critical to operation should be placed in preferential positions (see 5.2.1 and 5.2.2).

5.2.3.6.7 Simultaneous use. Visual displays that must be monitored concurrently with manipulation of a related control should be located sufficiently close to the control so that the operator is not required to observe the display from an extreme visual angle and thus introduce the possibility of parallax error,

5.2.3.6.8 Emergency use. Emergency displays and controls should be located where they can be seen and reached with minimum delay (warning lights within a 15° cone about the operator's nominal line of sight; emergency control close to the nearest, available hand in its nominal operating position).

5.2.3.7 Design factors.

5.2.3.7.1 Control/display identification. Except for controls whose function and appearance is obvious (steering wheel, joystick), all operator and maintainer controls and displays should have appropriate labels to aid in their identification. This should apply not only to individual items, but also to functional groups of controls and displays. Functional groups may be set apart by means of spatial separation, outlines around the group, and/or contrasting panel backgrounds. When outline borders are used they should not be wider than the character stroke width in the associated function labels, except for the panels containing emergency or extremely critical functions where the border width may be twice the character stroke width. Borders on gray panels should be marked in black (FED-STD-595, color #27038); or for

MIL-HDBK-759B

emergency panels, the border should be red (FED-STD-595, color # 21 136) unless red illumination is used, in which case it should be striped in yellow and black (FED-STD-595 yellow #23538 and black #27038). Background pads may be used subject to approval by the acquiring activity. Critical and non-critical control/display areas in aircraft crew stations should be delineated in accordance with MIL-M-18012 and MIL-C-81 774. For other display-control labeling and marking see 5.5.

5.2.3.7.2 Consistence. Similar control/display functions should be consistent from one operator workstation to another when it is likely that the same operator may be called upon to change workstations. Examples are listed below.

- a. Left-riah arrangements. When a group of control/display elements normally have a left-to-right and/or numbered relationship to other equipment components (aircraft engines numbered from left to right), the operator control/display arrangement should remain the same with respect to the operator's orientation within the workstation (facing forward, right, left, or aft).
- b. Related but separated control/display arrays. When an array of controls on one panel corresponds to displays mounted on another panel because of special space limitations, the control and display arrays should be similarly arranged. That is, the left-most control of a horizontal array should correspond to the left-most display mounted on the other panel, or a top-most control of a vertical array should correspond to the top-most display on the other panel. Two horizontal panels should not be mounted so that they "face" each other and thus create the opportunity to confuse the right-to-left relationships.
- c. Vertical vs horizontal control/disday arrangements. When displays are arranged in a row or column the associated controls should be similarly arranged and spaced (see Figure 41), except as follows:
 - (1) Fewer rows of controls than displays. Controls affecting the top row of displays should be positioned at the far left; controls affecting a second row of displays should be placed immediately to the right of these, with an appropriate space between the two-control arrays.

MIL-HDBK-759B

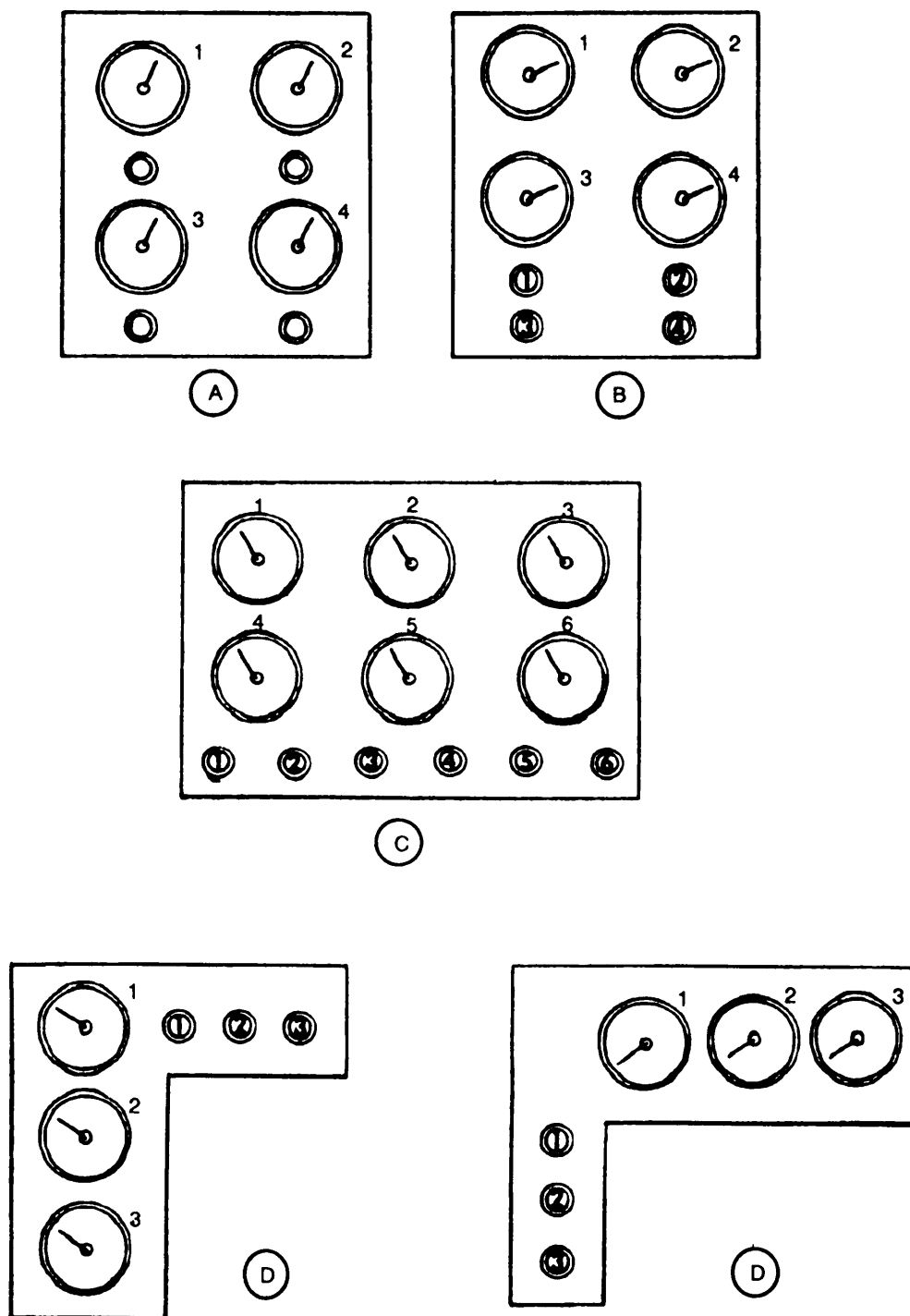

FIGURE 41. Control/display relationship

MIL-HDBK-759B

- (2) Vertical vs horizontal association. If a horizontal row of displays should be related to a vertical row of controls or vice versa, the farthest left item in the horizontal array should correspond to the top item in the vertical array. Exceptions often lead to errors in spite of the recommended spatial associations; therefore, they should be avoided whenever possible.
- (3) Multiple display vs single control. When the manipulation of one control requires reading of several displays, it should be "centered" as near as possible below the display group.
- (4) Multiple display vs ganged control. When up to three displays are to be individually affected by a three-layer, ganged rotary control switch, the switch should be centered below a horizontal display group, or to the right of a vertical display group. The knob-display associations should be as follows:
 - (a) Top knob - right display or upper display
 - (b) Middle knob - middle display
 - (c) Bottom knob - left display or lower display

5.2.3.8 Control/display movement ratio.

5.2.3.8.1 General. Control/display movement ratios for continuous adjustment controller tasks should be selected so as to minimize the total time required for the operator to work the desired control movement (to accommodate both response time and precision-setting criteria).

5.2.3 .8.1.1 Coarse vs fine setting. The amount of control and/or display movement should be compatible with the operator's inherent capacity to discriminate visual and tactile inputs from displayed elements and/or control movement feedback. For coarse setting tasks, control movement should be less than display movement; for fine setting tasks, control movement should be greater than display movement. When a task may include criteria for both coarse and fine setting, the control/display ratio should be chosen to minimize the time to make control settings. At operator stations where some tasks require only coarse settings, but others require fine settings, the operator should be provided with two selectable ratios, normal and fine.

5.2.3 .8.1.2 Hand vs foot controls. Foot controls should be used only for coarse adjustments or settings. Hand/arm-operated controls may be used for both coarse and fine adjustment. The more precision required, the less arm movement should be involved in control operation.

5.2.3.8.2 Coarse setting. The following criteria should apply:

- a. Knob/linear scale -1 full knob rotation = approximately 150 mm of display element movement

MIL-HDBK-759B

- b. Lever/linear scale -1 to 2 units of lever movement = 1 unit of display element movement
- c. Steering wheel - approximately 3 +/-1/2 turns of the wheel = lock-to-lock

5.2.3.8.3 Fine Setting. The following criteria should apply:

- a. Knob/linear scale -1 full knob rotation = 25 to 50 mm of display element movement
- b. Lever/linear scale -3 to 4 units of lever movement = 1 unit of display element movement

5.2.3.8.4 Bracketing for determining maximum or minimum values. When bracketing is used to locate a maximum or minimum rather than a specific value (as in tuning a transmitter), the control knob should swing through an arc of at least +/-10° but not more than +/- 30°, either side of the target value, in order to make the peak of dip associated with that value clearly noticeable.

5.2.3.8.5 Counter-setting. The criteria listed below should apply.

- a. Multi-digit mechanical drum counters. One revolution of a knob should equal approximately 50 counts (right-hand drum rotates five times).
- b. Multi-digit electronically-displayed counters. A momentary switch-type control should be used. Both slow and fast speed (slew) operation should be provided so the operator can either slew through the digits rapidly (about two digits per second for the cell being read) or step through, one digit at a time. In the latter case, the system should preclude the operator advancing more than one character in the event the control is not released. However, a system in which both forward and reverse display changes can be made is preferred so that the operator can "backup" one or two digits rather than having to "cycle-through" the series to obtain the desired setting.
- c. Single-digit electronically-displayed counters. A momentary-contact step advance may be sufficient unless frequent setting is required in which case a two-speed switch should be provided as for the multi-digit counter.

5.2.3.8.6 Foot-operated controls. Foot-operated controls should not be used to adjust a visual display directly (other than indirect display of vehicle changes in direction, acceleration). If a directly-coupled display adjustment is to be made by foot-operated control movements, it should be only for gross, relatively slow, settings. Foot-operated controls, when used to control the direction of vehicle movement (as in small submersibles) should be instrumented to indicate the direction and magnitude of control surface actuation as well as the heading of the vehicle.

MIL-HDBK-759B

5.3 Dimensional workspace.

5.3.1 Workspace.

5.3.1.1 General. This section of the handbook has been prepared to consolidate information about the dimensional aspects of workspaces. Anthropometric data necessary for the planning and design of functional workspaces are presented. This information addresses design concerns pertaining to general types of seating access, and to standing, stationary and mobile workspaces, including the crew stations of combat vehicles. The key to proper workspace layout is to first give consideration to the accommodation of the operator(s) and his tasks, and then to the dimensioning of the overall workspace. Thus, insofar as it is consistent with the operational mission, the workspace should be laid out with the person as the primary consideration. The reverse, designing the workspace and then adding the person, is usually inefficient and most often not cost effective.

5.3.2 Anthropometry.

5.3.2.1 General. Design and sizing should ensure accommodation, compatibility, operability, and maintainability by at least 90% of the user population, which include females as well as males. Generally, design limits should be based on a range from the 5th to the 95th percentile values for critical body dimensions. For any body dimension, the 5th percentile value indicates that 5% of the population will be equal to or smaller than that value, and 95% will be larger; conversely, the 95th percentile value indicates that 95% of the population will be equal to or smaller than that value and 5% will be larger. Therefore, use of a design range from the 5th to the 95th percentile values will theoretically accommodate 90% of the user population for that dimension. The anthropometric data presented in this section in Figures 42 through 56 and Tables 28 through 47 are intended to provide general design guidance. Use of these data should take the following into consideration:

- a. the nature, frequency, and difficulty of the related tasks to be performed by the operator (or wearer) of the equipment,
- b. the position of the body during performance of these tasks,
- c. the mobility or flexibility criteria imposed by these tasks,
- d. the increments in the design-critical dimensions imposed by the need to compensate for obstacles and projections, and
- e. the increments in the design-critical dimensions imposed by protective clothing or equipment, packages, lines, and padding.

Caution. Extreme caution should be used when two or more dimensions are simultaneously used as criteria for design. Percentile values are not additive between different dimensions (see "An Alternative to Percentile Model" by K.M. Robinette and J.T. McConville 1982 SAE Technical Paper Series No. 810217). For example, it is incorrect to assume that the combination of the 5th percentile values will describe the

MIL-HDBK-759B

dimensions of a “5th percentile man.” In practice, the 5th to 95th percentile values of some dimensions will have to be exceeded in order to accommodate the same range in another key dimension. Therefore, the percentile values reported in this section are inadequate for designs where two or more dimensions are used simultaneously as design parameters. Instead, appropriate multivariate data and techniques should be used (see: “Computerized Accommodated Percentage Evaluation (CAPE) Model for Cockpit Analysis and Other Exclusion Studies” by A. Bittner, 1975 Pacific Missile Test Center, TP-75-49; and “A Family of Manikins for Workstation Design” by A. Bittner, 1986 NAEC-TR-2100-07B).

5.3.2.2 Anthropometric data. The anthropometric data presented in the following tables are nude body measurements; data are given in centimeters unless another unit of measure is indicated. The data on US Army Male Pilots (N = 493) were compiled from a subset of pilot data from the 1988 Anthropometric Survey of US Army Personnel (ANSUR). These data represent only US Army Male Pilots and do not include any members of the remaining flight crew. The data on US Army Female Pilots (N = 334) were compiled from a subset of women from the ANSUR data pool. They were selected to match the demographic distribution of current female Army Pilots. All the females selected for inclusion in the female pilot data set met the body size criteria for entry into pilot training. The data on US Army Men (N = 1774) were compiled from the ANSUR data pool. The data represented ground troops, infantrymen, armored crewmen, and a very few basic trainees, all under the heading “general forces”. The data on US Army Women (N = 2208) were also compiled from the ANSUR data pool. Tables 28 through 47 include the percentile values for each dimension, a range value, and minimum and maximum values. The range value is a measure between the 1st and 99th percentile, and not between the minimum and maximum values.

5.3.2.3 Use of data.

5.3.2.3.1 Data limitations. Because the anthropometric data presented here represent nude body measurements, suitable allowances should be made for light or heavy clothing, flying suits, helmets, boots, body armor, load-carrying equipment, protective equipment, and other worn or carried items, when using these data for design criteria. Examples of the changes in anthropometric values imposed by different clothing ensembles, and more specific information for these data may be found in “Anthropometry of the Clothed US Army Ground Troop and Combat Vehicle Crewmen” by R.F. Johnson, NATICK/TR-84/034. In addition to clothing and equipment concerns, different cockpits and crewstations often require their operators to assume different postures which may change as the operator fatigues. Because the anthropometric data presented here is derived from measurements taken in standard anthropometric postures, suitable allowances should be made for postural variation. Further information may be found in MIL-STD-1333 “Aircrew Station Geometry for Military Aircraft” or from the appropriate service agency responsible for anthropometry.

MIL-HDBK-759B

5.3.2.3.2 Clearance dimensions. Clearance dimensions (for passageways and accesses), which should accommodate or allow passage of the body or part of the body, should be based upon the appropriate body dimension of the largest potential user as defined in the design criterion.

5.3.2.3.3 Limiting dimensions. Limiting dimensions (reaching distance, control movement, displays, test points, handrails) which restrict or are limited by extensions of the body should be based upon the body dimension of the smallest potential user as defined in the design criterion.

5.3.2.3.4 Adjustable dimensions. Seats, restraint systems, safety harnesses, belts, controls, or any equipment that should be adjusted for the comfort or performance of the individual user should be adjustable over the range of the smallest to largest values for the applicable body dimension(s) of the potential users as defined in the design criterion.

5.3.2.3.5 Clothing and personal equipment. Clothing and personal equipment (including protective or specialized equipment worn or carried by the individual) should be designed and sized to accommodate at least the 5th through 95th percentile values of body dimensions. Pertinent dimensions of mission essential or life protecting equipment (body armor, respirators) should accommodate at least the 1st through 99th percentile values. Where two or more dimensions are used simultaneously as design parameters, appropriate multivariate data and techniques should be used.

5.3.2.3.6 Special populations. Where equipment will be exclusively used by segments of the military with specific anthropometric entrance criteria (military police, divers) or population ranges other than the 5th-95th percentiles, appropriate anthropometric data should be used. As discussed in 5.3.2.4.1, where equipment is intended for use by foreign military personnel, appropriate anthropometric data on such populations should be used for design and sizing criteria. Contact the appropriate service agency responsible for anthropometry to obtain data on these specialized populations.

5.3.2.3.7 Correlation between body measurements. The anthropometric data shown in the following tables represent values for individual body measurements. These are values for each independent measurement and, as such, give no indication of the interrelationships or correlations among the various body measurements.

5.3.2.3.7.1 Use of two or more measurements in design. In design work, human engineering, or any other application of anthropometric data, measurements of a single body dimension are seldom used alone. Usually, two or more measurements should be considered together. Stature and chest circumference, as well as waist circumference, are utilized in the sizing of many items of clothing, while neck circumference and sleeve length are needed for shirts, and waist circumference and crotch height are required for trousers. Similarly, in human engineering applications, sitting height and functional reach, for example, are used in the design of vehicles and aircraft, while hip breadth, sitting and popliteal height are required for the design of seating.

MIL-HDBK-759B

5.3.2.3.7.2 Variability of relationship between measurements. The relationships or correlations between body measurements are highly variable. Certain dimensions may not always have the same influence on other dimensions.

5.3.2.3.7.3 Highly-correlated measurements. In general, height measurements (waist height, crotch height, sitting height) and the lengths of the arms or legs are highly correlated with stature. Circumference measurements or body girths are more likely correlated with weight. Breadth measurements tend to be more highly correlated with weight than with stature.

5.3.2.3.7.4 Expression of relationship between measurements. The degree of relationship may be expressed by a correlation coefficient or "r" value. The "r" value describes the degree to which two variables vary together (positive correlation) or vary inversely (negative correlation). The correlation coefficient, "r", has a range of values from +1.0 (perfect positive correlation) through -1.0 (perfect negative correlation).

5.3.2.3.8 Bivariate tables. The variability of two body measurements and their interrelationship with each other may be shown graphically in a bivariate table. The bivariate table shows the ranges of two measurements and the numbers or frequencies of individuals who have the various possible combinations of values of the two measurements. The values indicating the ranges of the two measurements represent the midpoints of the intervals in those ranges. The frequencies or numbers of individuals may be given as actual numbers or may be expressed as percentages of the sample. While the relationship between two measurements is summarized by the coefficient of correlation, or "r" value, the extent or degree of correlation may also be estimated from the appearance or general shape of the bivariate distribution. A bivariate table, which shows a fairly well-defined band sloping from the lower left to upper right indicates a high degree of correlation that would normally be confirmed by a comparatively high coefficient of correlation (0.7 and higher). If this slope is absent, and the distribution is oval in shape, that means the correlation coefficient is low, and that the two variables are not changing in a similar fashion. See Table 27 for a bivariate frequency table for waist circumference and crotch height.

5.3.2.3.9 Regression analysis. The coefficient of correlation is a measure of the relationship between variables. Given values of one variable, it is possible to predict the value of another variable. The predictive relationship between two variables can be shown in terms of a "line of best fit," or in terms of the mathematical definition of this line, called a "regression line." The application of regression analysis is useful for predicting measurements and relationships between measurements when an actual sample is not available. It should be noted that the data presented in this document are percentile data, and that they are inappropriate for use in calculation of coefficients of correlation, bivariate tables, and regression analyses. The contractor should contact the appropriate service agency responsible for anthropometry, and obtain raw data for use in these statistical tests.

MIL-HDBK-759B

TABLE 27. A bivariate frequency table for waist circumference and crotch height (cm)

	CROTCH HEIGHT																				TOT						
	65 .50	67 .00	68 .50	70 .00	71 .50	73 .00	74 .50	76 .00	77 .50	79 .00	80 .50	82 .00	83 .50	85 .00	86 .50	88 .00	89 .50	91 .00	92 .50	94 .00		95 .50	97 .00	98 .50	100 .00	101 .50	ALS
127.50																										0	
125.00																											0
122.50																											0
120.00																											2
117.50																											3
115.00																											4
112.50																											9
110.00																											18
107.50																											17
105.00																											36
102.50																											56
100.00																											73
97.50																											93
95.00																											158
92.50																											206
90.00																											284
87.50																											397
85.00																											503
82.50																											647
80.00																											908
77.50																											937
75.00																											964
72.50																											699
70.00																											448
67.50																											160
65.00																											46
62.50																											8
60.00																											3
Totals	1	2	6	13	21	64	110	174	333	468	645	834	872	842	702	587	411	272	154	85	40	21	8	5	1	6682	

W A I S T C I R C U M F E R E N C E
CROTCH HEIGHT
MEAN 80.30
STD DEV 8.18
REGRESSION EQUATIONS
 $.005^*X + 79.877$
 $.002^*Y + 83.782$
SE-EST 8.18
R .003

MIL-HDBK-759B

This Page Intentionally Left Blank.

MIL-HDBK-759B

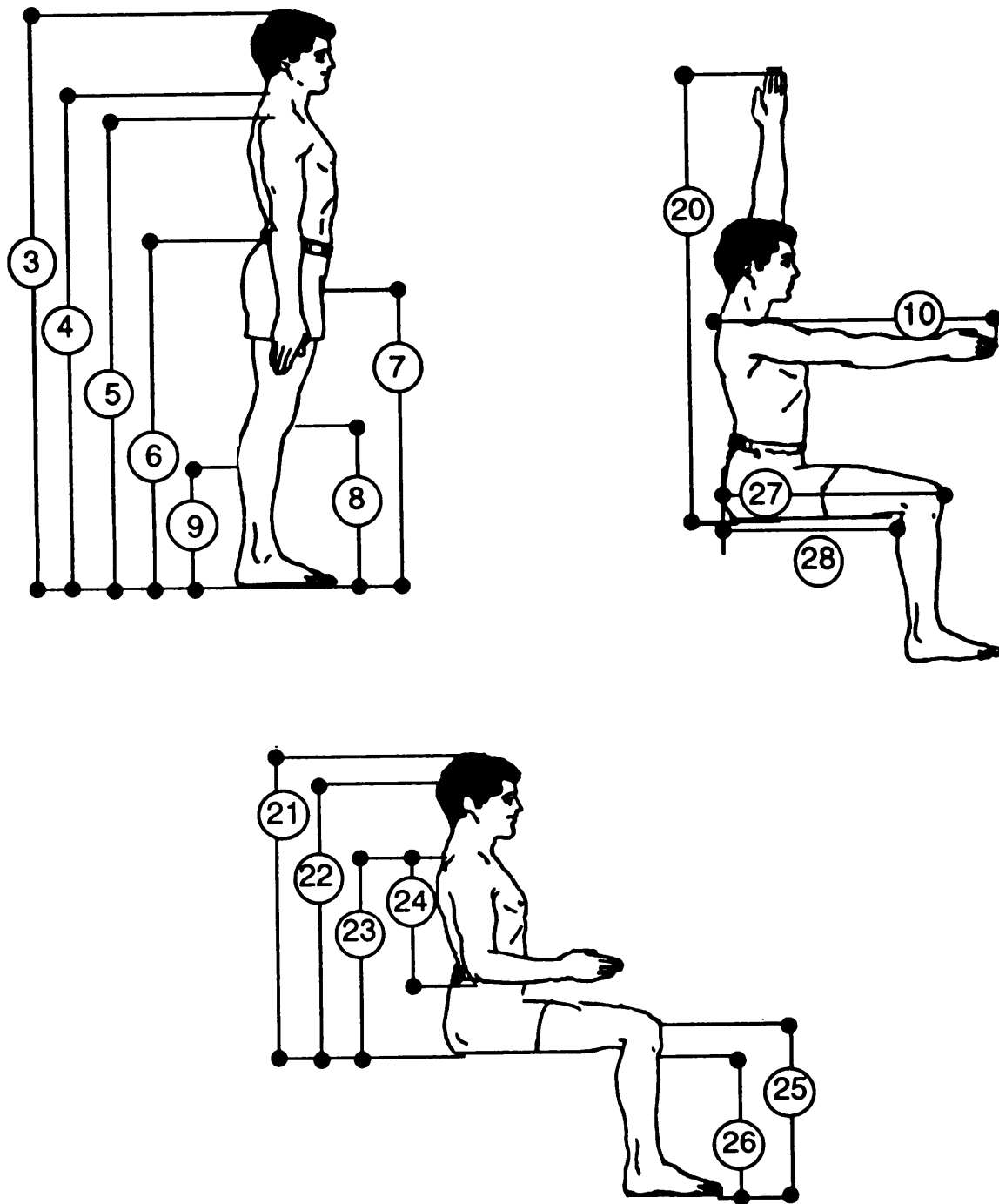

FIGURE 42. US Army men (1988): standing and sitting measurements

MIL-HDBK-759B

TABLE 28. US Army men (1988): standing and sitting measurements

No.	Measurements	Percentiles in Centimeters											Range (1st-99th)		
		1st	2nd	5th	10th	25th	50th	75th	90th	95th	98th	99th	MIN	MAX	
2	Weight (kilograms)	55.27	57.83	61.59	64.93	70.71	77.69	85.45	93.16	98.07	103.8	107.71	52.44	47.60	127.80
STANDING MEASUREMENTS															
3	Stature	160.27	162.05	164.69	167.03	170.99	175.49	180.09	184.23	186.65	189.24	190.87	30.60	149.70	204.20
4	Cervicale Height	137.36	139.24	141.83	144.01	147.62	151.78	156.16	160.15	162.43	164.76	166.10	28.72	126.70	177.60
5	Acromiale Height	129.86	131.62	134.16	136.35	140.02	144.18	148.46	152.32	154.56	156.93	158.38	28.52	118.20	170.40
6	Wrist Height, Omphalion	94.20	95.61	97.67	99.46	102.45	105.82	109.28	112.40	114.26	116.31	117.63	23.43	86.00	130.50
7	Crotch Height	73.16	74.56	76.44	77.99	80.53	83.50	86.75	89.83	91.64	93.53	94.64	21.48	67.50	106.70
8	Knee Height, Micopetelia	44.30	45.05	46.10	47.01	48.56	50.39	50.34	54.13	55.16	56.21	56.81	12.51	40.60	62.00
9	Calf Height	30.24	30.75	31.57	32.33	33.69	35.27	36.93	38.46	39.39	40.45	41.16	10.92	27.10	44.20
10	Thumbtip Reach	71.98	72.69	73.92	75.14	77.37	80.00	82.70	85.18	86.70	88.46	89.68	17.70	66.20	98.00
SITTING MEASUREMENTS															
20	Overhead Fingertip Reach, Sitting	129.31	131.19	133.78	135.93	139.42	143.42	147.46	151.04	153.17	155.39	156.72	27.41	116.40	169.30
21	Sitting Height	82.79	83.88	85.45	86.79	88.99	91.42	93.86	95.99	97.19	98.42	99.14	16.35	80.80	103.20
22	Eye Height, Sitting	71.18	72.11	73.50	74.76	76.88	79.23	81.55	83.61	84.80	86.10	86.93	15.75	67.30	90.30
23	Mid-Shoulder Height	56.28	57.12	58.34	59.39	61.12	63.04	64.97	66.67	67.66	68.71	69.36	13.08	53.80	73.00
24	Shoulder-Elbow Length	32.88	33.33	34.02	34.64	35.69	36.88	38.10	39.21	39.88	40.63	41.13	8.25	29.70	44.60
25	Knee Height, Sitting	49.66	50.38	51.44	52.36	53.95	55.80	57.75	59.54	60.57	61.67	62.34	12.68	45.40	67.50
26	Popliteal Height	37.83	38.49	39.46	40.30	41.70	43.32	45.03	46.64	47.63	48.75	49.49	11.66	33.80	54.70
27	Buttock-Knee Length	55.07	55.81	56.90	57.87	59.55	61.54	63.65	65.60	66.74	67.95	68.69	13.62	50.60	72.30
28	Buttock-Popliteal Length	44.13	44.81	45.81	46.70	48.21	49.96	51.81	53.53	54.55	55.68	56.40	12.27	40.10	59.70

MIL-HDBK-759B

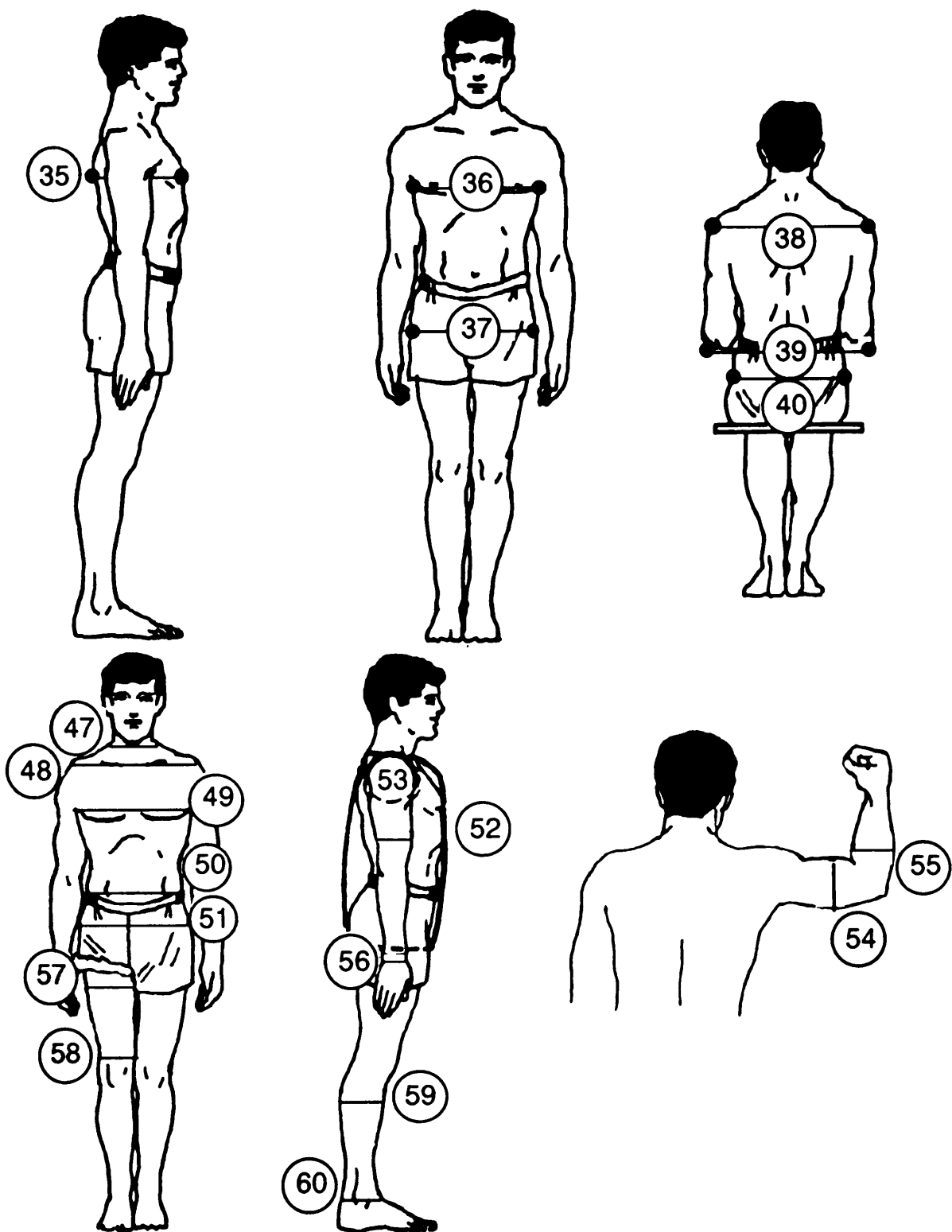

FIGURE 43. US Army men (1988): breadth and circumference measurements

MIL-HDBK-759B

TABLE 29. US Army men (1988): breadth and circumference measurements

No.	Measurements	Percentiles in Centimeters										Range (1st-99th)	MIN	MAX	
		1st	2nd	5th	10th	25th	50th	75th	90th	95th	98th				99th
BREADTH MEASUREMENTS															
35	Chest Depth	19.67	20.20	20.96	21.64	22.82	24.22	25.73	27.17	28.04	28.99	29.60	9.93	18.50	32.20
36	Chest Breadth	27.06	27.55	28.31	29.02	30.32	31.94	33.76	35.55	36.67	37.95	38.81	11.75	25.70	42.20
37	Hip Breadth, Standing	29.64	30.18	30.97	31.66	32.81	34.12	35.49	36.82	37.65	38.64	39.32	9.68	28.20	41.60
38	Bideltoid Breadth	43.40	44.02	44.99	45.87	47.39	49.14	50.92	52.53	53.48	54.50	55.16	11.76	41.00	59.30
39	Forearm-Forearm Breadth	45.12	46.17	47.74	49.16	51.59	54.45	57.47	60.32	62.06	64.00	65.27	20.15	39.90	72.50
40	Hip Breadth, Sitting	31.15	31.90	32.87	33.64	34.91	36.47	38.28	40.07	41.16	42.32	43.00	11.85	29.90	48.40
CIRCUMFERENCES															
47	Neck Circumference	33.66	34.17	34.90	35.53	36.61	37.87	39.23	40.53	41.34	42.35	42.86	9.20	31.60	47.00
48	Shoulder Circumference	103.66	105.32	107.77	109.92	113.49	117.44	121.47	125.25	127.61	130.38	132.30	28.64	96.60	142.40
49	Chest Circumference	84.50	86.16	88.55	90.66	94.29	98.69	103.58	108.33	111.28	114.63	116.82	32.32	77.50	126.10
50	Waist Circumference, Omphalion	69.65	71.01	73.26	75.51	79.86	85.55	91.95	98.02	101.59	105.38	107.67	38.02	65.40	116.50
51	Buttock Circumference	84.76	86.34	88.63	90.64	94.08	98.12	102.45	106.54	109.03	111.79	113.57	28.81	80.50	123.90
52	Vertical Trunk Circumference	144.55	147.11	150.64	153.54	158.09	163.01	168.13	173.13	176.34	180.19	182.9	38.35	137.70	190.40
53	Scye Circumference	38.42	39.18	40.27	41.20	42.73	44.46	46.27	48.02	49.13	50.45	51.36	12.94	35.80	55.30
54	Biceps Circumference, Flexed	27.68	28.48	29.57	30.47	31.91	33.56	35.40	37.27	38.50	39.99	41.03	13.35	25.90	43.70
55	Forearm Circumference, Flexed	26.29	26.78	27.47	28.06	29.05	30.24	31.56	32.83	33.61	34.47	35.02	8.73	23.30	37.20
56	Wrist Circumference	15.59	15.81	16.13	16.40	16.86	17.40	17.97	18.51	18.84	19.21	19.44	3.85	14.30	20.40
57	Thigh Circumference	48.72	49.85	50.60	53.33	56.25	59.58	62.96	66.04	67.90	70.03	71.46	22.74	45.80	78.70
58	Lower Thigh Circumference	31.93	32.52	33.46	34.34	35.87	37.63	39.48	41.31	42.52	44.03	45.14	13.21	30.30	49.20
59	Calf Circumference	32.13	32.71	33.64	34.52	36.05	37.78	39.52	41.10	42.07	43.19	43.97	11.84	30.40	47.00
60	Ankle Circumference	19.32	19.57	20.02	20.47	21.28	22.19	23.06	23.82	24.27	24.79	25.15	5.83	17.70	26.70

MIL-HDBK-759B

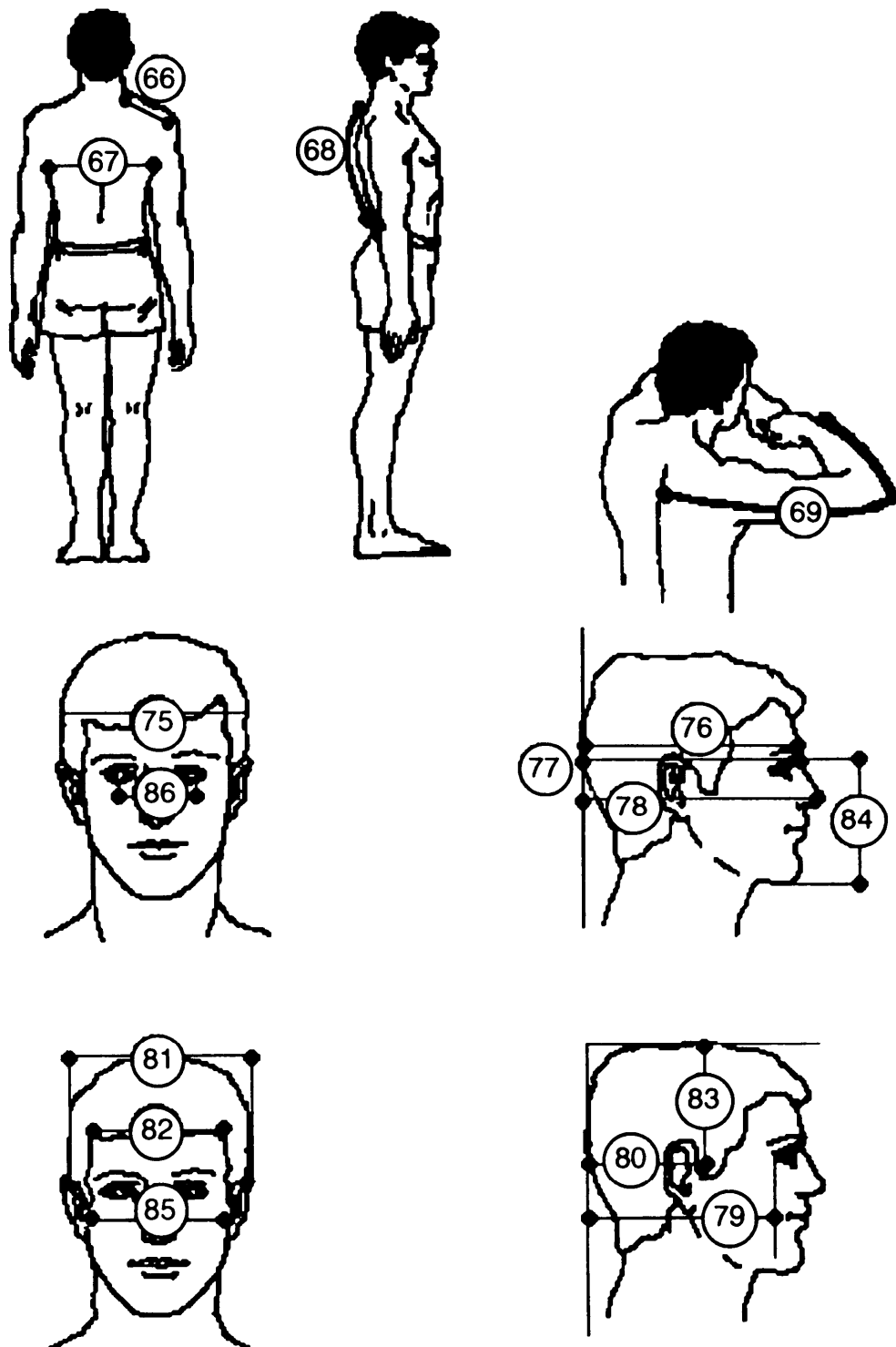

FIGURE 44. US Army men (1988): surface, head and face measurements

MIL-HDBK-759B

TABLE 30. US Army men (1988): surface, head and face measurements

No.	Measurements	Percentiles in Centimeters											Range		
		1st	2nd	5th	10th	25th	50th	75th	90th	95th	98th	99th	MIN	MAX	
SURFACE MEASUREMENTS															
66	Shoulder Length	12.44	12.79	13.26	13.66	14.30	15.02	15.78	16.49	16.91	17.37	17.66	5.22	11.40	18.50
67	Interscye	33.23	34.02	35.19	36.21	37.97	40.04	42.25	44.32	45.56	46.91	47.77	14.54	28.50	54.10
68	Waist Back Length, Omphalion	41.91	42.53	43.54	44.47	46.06	47.81	49.55	51.21	52.32	53.72	54.78	12.87	38.50	57.10
69	Sleeve Length, Spine-Wrist	80.12	81.06	82.49	83.78	86.00	88.54	91.15	93.52	94.93	96.50	97.51	17.39	73.10	103.70
HEAD AND FACE MEASUREMENTS															
Percentiles in Centimeters															
75	Head Circumference	53.32	53.69	54.27	54.81	55.73	56.75	57.77	58.73	59.35	60.10	60.65	7.33	51.40	62.70
76	Head Length	18.01	18.23	18.53	18.81	19.25	19.72	20.18	20.60	20.85	21.14	21.34	3.33	17.30	22.00
77	Sellion-Back of Head	17.97	18.19	18.51	18.79	19.25	19.72	20.17	20.59	20.85	21.18	21.42	3.45	17.40	22.10
78	Pronasale-Back of Head	19.97	20.19	20.54	20.87	21.42	21.96	22.45	22.89	23.19	23.60	23.93	3.96	18.80	24.70
79	Ectoorbitale-Back of Head	14.54	14.70	14.96	15.19	15.59	16.02	16.43	16.80	17.03	17.30	17.49	2.95	14.00	18.50
80	Tragion-Back of Head	8.54	8.70	8.94	9.15	9.50	9.89	10.28	10.64	10.85	11.10	11.26	2.72	8.00	12.00
81	Head Breadth	13.92	14.08	14.31	14.50	14.81	15.15	15.51	15.86	16.08	16.34	16.52	2.60	12.80	17.30
82	Minimum Frontal Breadth	9.38	9.50	9.69	9.86	10.16	10.49	10.84	11.17	11.38	11.65	11.84	2.48	8.20	12.70
83	Tragion-Top of Head	11.75	11.93	12.18	12.39	12.72	13.09	13.47	13.82	14.04	14.29	14.46	2.71	11.20	15.10
84	Menton-Sellion Length	10.75	10.88	11.10	11.31	11.68	12.10	12.53	12.93	13.18	13.49	13.70	2.95	9.90	14.70
85	Bizygomatic Breadth	12.89	13.06	13.31	13.54	13.91	14.32	14.75	15.15	15.40	15.69	15.88	2.99	11.50	17.00
86	Interpupillary Breadth	5.68	5.76	5.88	6.00	6.21	6.45	6.71	6.96	7.10	7.27	7.38	1.70	5.20	7.80

MIL-HDBK-759B

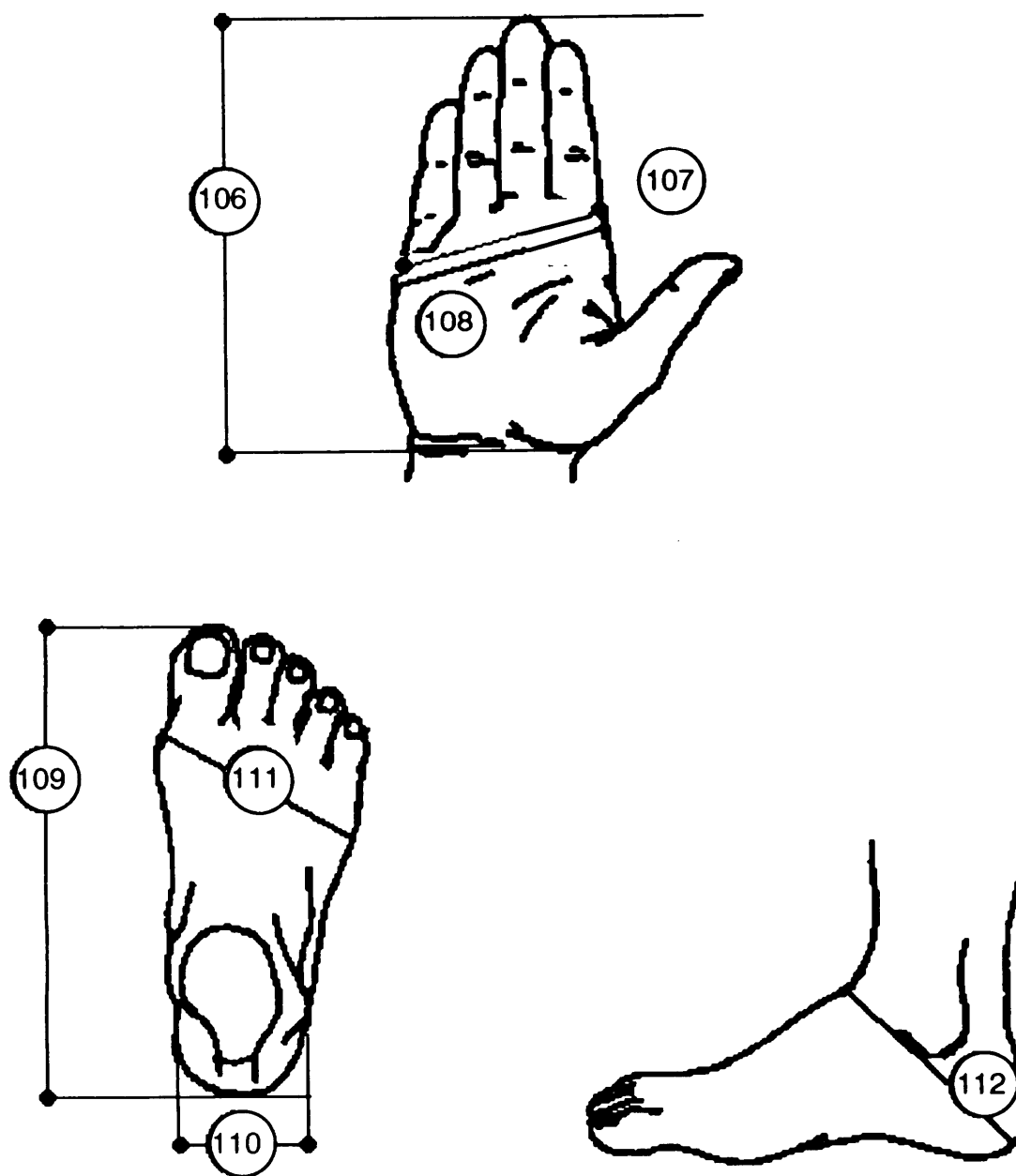

FIGURE 45. US Army men (1988): hand and foot measurements

MIL-HDBK-759B

TABLE 31. US Army men (1988): hand and foot measurements

No.	Measurements	Percentiles in Centimeters											Range (1st-99th)	MIN	MAX	
		1st	2nd	5th	10th	25th	50th	75th	90th	95th	98th	99th				
HAND MEASUREMENTS																
106	Hand Length	17.28	17.52	17.87	18.18	18.71	19.33	19.99	20.64	21.06	21.55	21.90	21.90	4.62	16.00	23.30
107	Hand Breadth	8.07	8.19	8.36	8.51	8.75	9.03	9.32	9.59	9.76	9.93	10.04	10.04	1.97	7.70	10.60
108	Hand Circumference	19.16	19.45	19.85	20.18	20.72	21.34	22.01	22.64	23.03	23.46	23.74	23.74	4.58	18.20	24.70
FOOT MEASUREMENTS																
109	Foot Length	23.99	24.35	24.88	25.33	26.08	26.93	27.82	28.67	29.20	29.81	30.21	30.21	6.22	22.80	31.00
110	Heel Breadth	5.97	6.07	6.23	6.38	6.64	6.97	7.34	7.71	7.95	8.24	8.45	8.45	2.48	5.50	9.00
111	Ball of Foot Circumference	22.04	22.40	22.90	23.32	24.02	24.82	25.66	26.45	26.92	27.45	27.78	27.78	5.74	21.00	30.00
112	Heel-Ankle Circumference	30.31	30.69	31.29	31.84	32.80	33.87	34.96	35.99	36.65	37.46	38.04	38.04	7.73	28.80	40.20

MIL-HDBK-759B

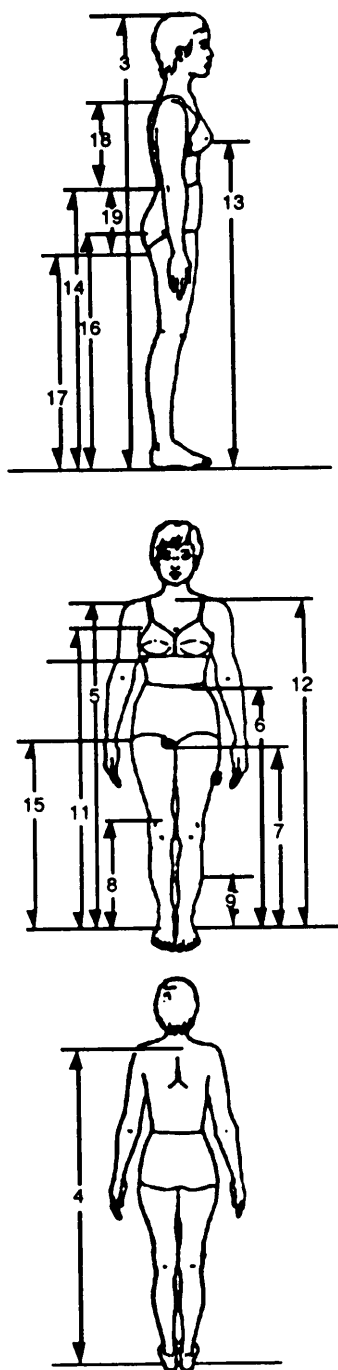

FIGURE 46. US Army women (1988): standing measurements

MIL-HDBK-759B

TABLE 32. US Army women (1988): standing measurements

No.	Measurements	Percentiles in Centimeters													Range (1st-99th)	MIN	MAX
		1st	2nd	5th	10th	25th	50th	75th	90th	95th	98th	99th					
2	Weight (kilograms)	45.24	47.02	49.64	51.98	56.12	61.25	67.13	73.11	76.98	81.56	84.70	89.46	96.7			
STANDING MEASUREMENTS																	
3	Stature	148.32	150.18	152.78	154.97	158.58	162.72	167.13	171.27	173.73	176.39	178.04	29.72	142.80	187.00		
4	Cervicale Height	127.32	128.99	131.35	133.37	136.73	140.61	144.71	148.53	150.80	153.25	154.77	27.45	121.20	164.30		
5	Acromiale Height	119.82	121.63	124.09	126.12	129.40	133.16	137.19	140.97	143.20	145.57	146.99	27.17	113.90	156.50		
6	Waist Height, Omphallon	86.89	88.30	90.30	92.01	94.86	98.09	101.48	104.61	106.47	108.49	109.76	22.87	80.20	117.50		
7	Crotch Height	67.00	68.23	70.02	71.58	74.15	77.01	79.98	82.80	84.58	86.68	88.14	21.14	59.40	94.80		
8	Knee Height, Midpatella	39.94	40.64	41.67	42.58	44.10	45.81	47.57	49.23	50.25	51.48	52.27	12.33	35.80	58.40		
9	Calf Height	26.48	26.99	27.82	28.60	29.97	31.54	33.16	34.71	35.71	36.92	37.80	11.32	23.60	41.30		
11	Axilla Height	110.67	112.42	114.75	116.64	119.69	123.18	129.96	130.52	132.63	134.85	136.17	25.50	105.10	145.20		
12	Suprasternale Height	120.74	122.08	124.11	125.96	129.16	132.88	136.76	140.34	142.48	144.85	146.40	25.66	115.10	153.80		
13	Chest Height	105.13	106.70	108.85	110.66	113.65	117.20	121.07	124.73	126.89	129.17	130.53	25.40	99.60	140.20		
14	Elbow Rest Height, Standing	89.51	90.80	92.63	94.20	96.77	99.67	102.71	105.60	107.40	109.47	110.87	21.36	85.60	118.50		
15	Trochanteric Height	76.05	77.19	77.93	80.48	83.09	86.03	89.06	91.94	93.77	95.96	97.50	21.45	67.30	106.20		
16	Buttock Height	73.89	75.02	76.69	78.18	80.72	83.66	86.77	89.71	91.50	93.53	94.86	20.97	65.30	102.20		
17	Gluteal Furrow Height	64.79	65.89	67.54	69.01	71.50	74.33	77.27	80.03	81.74	83.71	85.04	20.25	56.80	91.60		
18	Acromion-Rectale Length	27.37	27.83	28.49	29.07	30.04	31.14	32.29	33.37	34.02	34.74	35.21	7.84	26.20	37.00		
19	Radiale-Stylole Length	20.97	21.32	21.87	22.39	23.28	24.30	25.35	26.33	26.94	27.65	28.14	7.17	15.70	31.20		

MIL-HDBK-759B

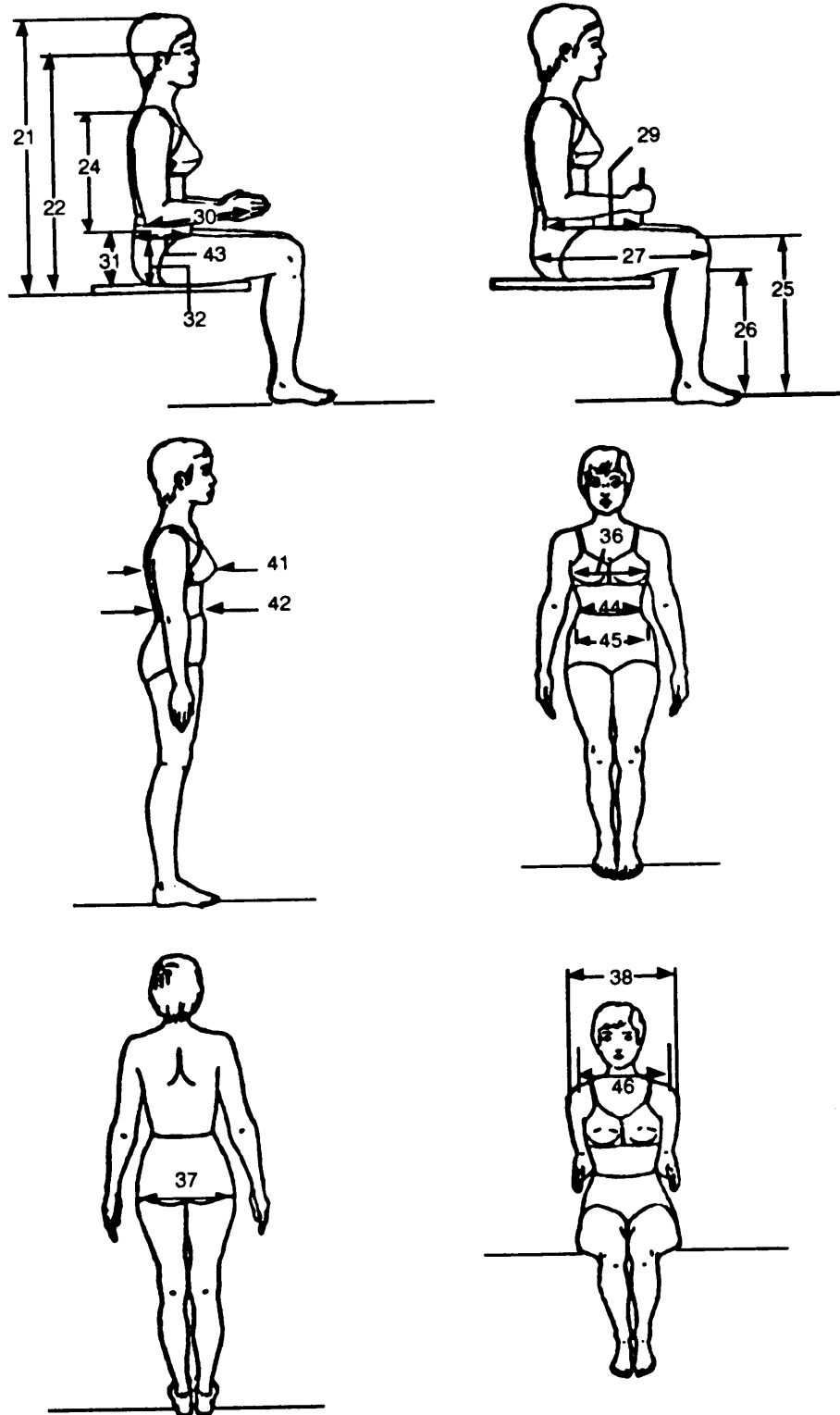

FIGURE 47. US Army women (1988): sitting, depth and breadth measurements

MIL-HDBK-759B

TABLE 33. US Army women (1988): sitting, depth and breadth measurements

No.	Measurements	Percentiles in Centimeters											Range (1st-99th)	MIN	MAX	
		1st	2nd	5th	10th	25th	50th	75th	90th	95th	98th	99th				
SITTING MEASUREMENTS																
21	Sitting Height	77.48	78.27	79.53	80.70	82.76	85.14	87.57	89.75	91.02	92.42	93.31	15.83	74.80	97.10	
22	Eye Height, Sitting	66.40	67.21	68.46	69.60	71.56	73.82	76.13	78.21	79.43	80.75	81.59	15.19	64.00	86.40	
24	Shoulder-Elbow Length	29.62	30.08	30.76	31.36	32.38	33.54	34.74	35.85	36.51	37.23	37.69	8.07	28.20	40.10	
25	Knee Height, Sitting	45.47	46.30	47.40	48.30	49.76	51.43	53.26	54.99	56.02	57.12	57.78	12.31	40.60	63.30	
26	Popliteal Height	33.67	34.24	35.13	35.93	37.30	38.89	40.53	42.04	42.94	43.96	44.63	10.96	29.90	50.00	
27	Buttock-Knee Length	52.18	53.03	54.21	55.20	56.85	58.78	60.85	62.81	63.98	65.24	66.02	13.84	49.10	69.10	
29	Elbow-Center of Grip Length	28.93	29.35	30.02	30.63	31.66	32.84	34.04	35.15	35.84	36.64	37.20	8.27	23.70	41.30	
30	Forearm-Hand Length	39.14	39.74	40.12	40.62	41.38	42.69	45.84	47.35	48.25	49.21	49.81	10.67	32.40	54.60	
31	Elbow Rest Height	15.80	16.49	17.57	18.56	20.24	22.08	23.89	25.49	26.44	27.52	28.24	12.44	12.40	30.20	
32	Thigh Clearance	13.38	13.64	14.04	14.40	15.04	15.82	16.67	17.50	18.02	18.61	19.01	5.63	12.10	20.60	
DEPTH AND BREADTH MEASUREMENTS																
36	Chest Breadth	24.01	24.43	25.04	25.60	26.58	27.79	29.17	30.59	31.51	32.63	33.41	9.40	22.20	37.50	
37	Hip Breadth, Standing	29.58	30.05	30.78	31.47	32.70	34.15	35.71	37.21	38.15	39.24	40.00	10.42	27.00	42.00	
38	Biceftoid Breadth	38.03	38.73	39.70	40.49	41.75	43.14	44.65	46.17	47.17	48.36	49.21	11.18	36.90	53.20	
41	Bust Depth	19.71	20.20	20.86	21.43	22.44	23.74	25.26	26.81	27.78	28.86	29.54	9.83	17.00	32.50	
42	Waist Depth, Omphalion	15.84	16.34	16.99	17.56	18.58	20.01	21.84	23.81	25.09	26.55	27.50	11.66	14.70	30.40	
43	Abdom. Ext. Depth Sitting	17.31	17.78	18.47	19.11	20.32	21.92	23.85	25.81	27.07	28.50	29.45	12.14	15.30	31.60	
44	Waist Breadth	23.72	24.18	24.89	25.58	26.88	28.63	30.72	32.86	34.22	35.77	36.79	13.07	22.50	39.00	
45	Bispinous Breadth	17.45	17.93	18.68	19.37	20.57	21.95	23.37	24.66	25.41	26.24	26.77	9.32	15.10	29.30	
46	Biacromial Breadth	31.82	32.46	33.32	34.02	35.12	36.30	37.46	38.48	39.06	39.65	40.00	8.18	30.10	41.70	

MIL-HDBK-759B

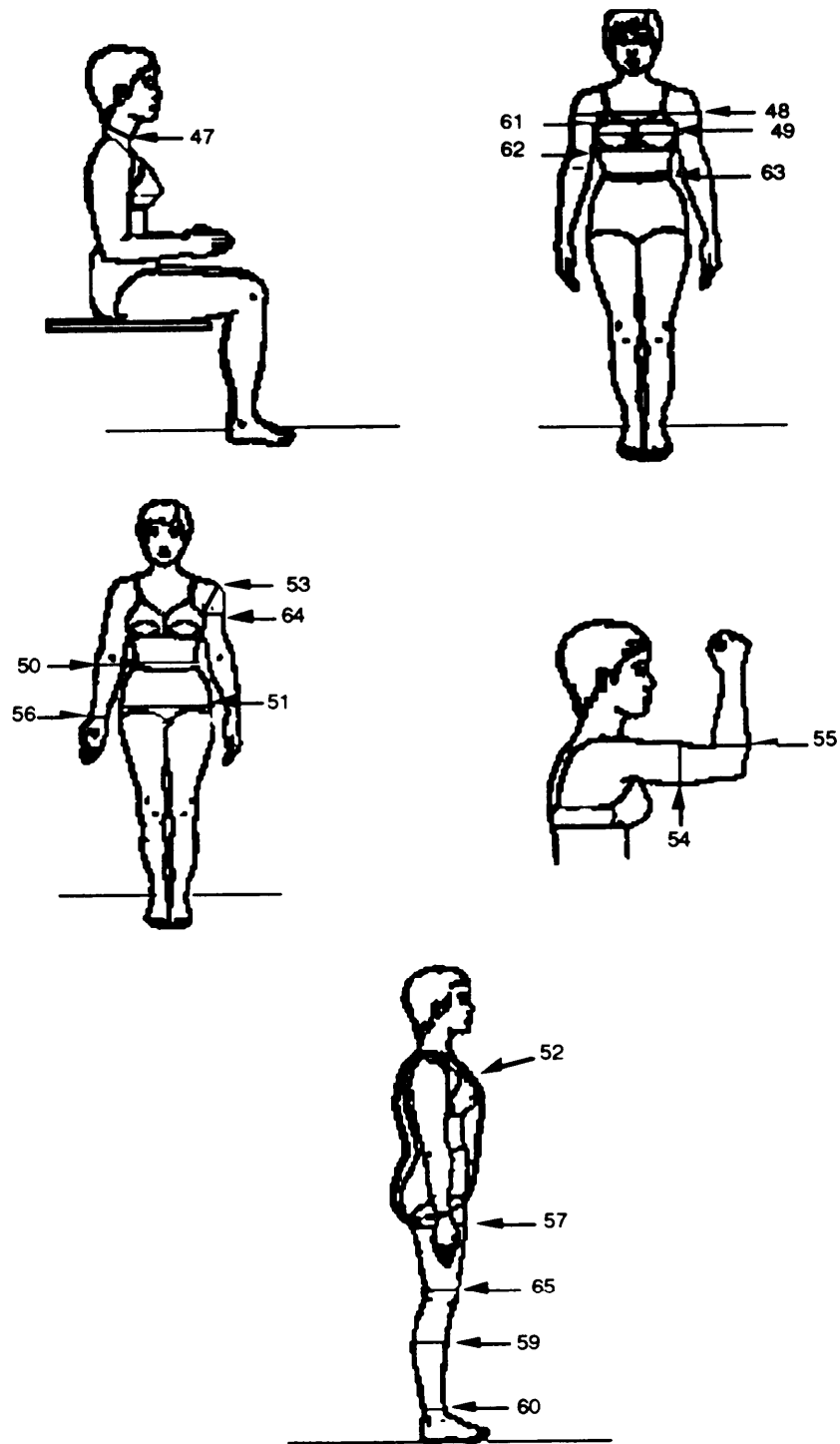

FIGURE 48. US Army women (1988): circumference measurements

MIL-HDBK-759B

TABLE 34. US Army women (1988): circumference measurements

No.	Measurements	Percentiles in Centimeters											Range (1st-99th)	MIN	MAX	
		1st	2nd	5th	10th	25th	50th	75th	90th	95th	98th	99th				
CIRCUMFERENCES																
47	Neck Circumference	28.43	28.73	29.22	29.68	30.50	31.48	32.54	33.58	34.25	35.04	35.60	35.60	7.17	27.20	37.20
48	Shoulder Circumference	91.38	92.71	94.64	96.32	99.12	102.37	105.92	109.50	111.85	114.68	116.70	116.70	25.32	86.20	126.10
49	Chest Circumference	78.14	79.49	81.41	83.12	86.18	90.09	94.68	99.32	102.24	105.54	107.69	107.69	29.55	71.10	117.60
50	Waist Circumference (Omphalion)	64.42	65.64	67.56	69.43	73.09	78.10	84.40	90.54	94.63	99.40	102.61	102.61	38.19	61.00	110.80
51	Buttock Circumference	84.14	85.25	87.18	89.09	92.51	96.47	100.56	104.47	107.00	110.13	112.45	112.45	28.31	78.70	118.90
52	Vert. Trunk Circum., Standing	137.99	139.57	142.04	144.32	148.26	152.79	157.51	162.01	164.84	168.21	170.58	170.58	32.59	132.30	177.30
61	Chest Circum. at Scye	77.61	78.97	80.82	82.38	85.00	88.22	91.96	95.80	98.28	101.16	103.09	103.09	25.48	75.30	112.10
62	Chest Circum. Below Breast	67.09	68.10	69.60	70.95	73.37	76.43	80.03	83.79	86.27	89.25	91.33	91.33	24.24	64.00	98.80
63	Waist Circum., Natural Indentation	60.69	61.96	63.74	65.30	68.08	71.73	76.21	81.07	84.32	88.27	91.03	91.03	30.34	56.80	98.70
LIMB CIRCUMFERENCES																
53	Scye Circumference	32.40	32.87	33.62	34.32	35.55	37.00	38.58	40.16	41.19	42.46	43.38	43.38	10.98	29.80	45.60
54	Biceps Circum., Flexed	23.14	23.76	24.62	25.35	26.56	27.98	29.56	31.13	32.10	33.22	33.96	33.96	10.82	21.30	37.10
55	Forearm Circum., Flexed	21.99	22.40	22.99	23.51	24.36	25.31	26.31	27.29	27.94	28.73	29.30	29.30	7.31	21.00	32.50
56	Wrist Circumference	13.61	13.78	14.03	14.26	14.65	15.10	15.57	16.02	16.29	16.61	16.82	16.82	3.21	12.90	17.40
57	Thigh Circumference	48.05	49.16	50.83	52.34	54.91	57.85	60.94	63.89	65.74	67.91	69.42	69.42	21.37	45.40	74.80
59	Calf Circumference	30.12	30.62	31.46	32.27	33.67	35.22	36.77	38.19	39.90	40.21	41.03	41.03	10.91	28.50	45.90
60	Ankle Circumference	17.99	18.21	18.60	19.00	19.70	20.51	21.31	22.70	22.56	23.18	23.64	23.64	5.65	15.90	24.90
64	Axillary Arm Circumference	23.89	24.53	25.41	26.16	27.44	28.98	30.72	32.43	33.49	34.68	35.45	35.45	11.56	22.30	37.70
65	Knee Circumference	31.58	32.11	32.93	33.67	34.93	36.38	37.94	39.53	40.60	41.97	42.99	42.99	11.41	30.20	46.10

MIL-HDBK-759B

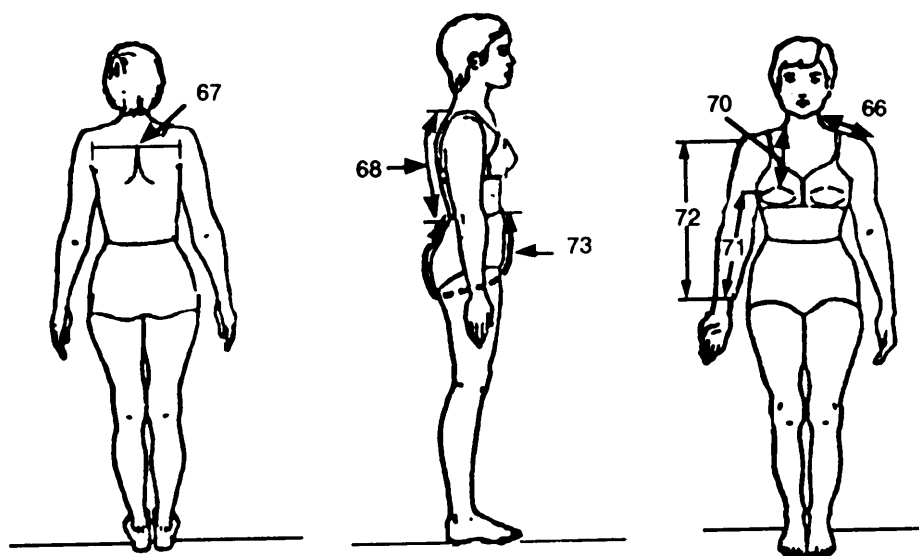

FIGURE 49. US Army women (1988): surface measurements

MIL-HDBK-759B

TABLE 35. US Army women (1988): surface measurements

No.	Measurements	Percentiles in Centimeters											Range			
		1st	2nd	5th	10th	25th	50th	75th	90th	95th	98th	99th	(1st-99th)	MIN	MAX	
SURFACE MEASUREMENTS																
66	Shoulder Length	11.97	12.23	12.66	13.05	13.73	14.47	15.19	15.84	16.24	16.73	17.08	17.08	5.11	11.10	18.20
67	Interscye I	32.14	32.69	33.61	34.48	35.98	37.64	39.25	40.69	41.57	42.61	43.35	43.35	11.21	28.40	47.00
68	Waist Back Length, Omphalion	38.98	39.52	40.37	41.16	42.58	44.16	45.83	47.44	48.47	49.71	50.60	50.60	11.62	36.30	55.50
70	Neck-Bustpoint/Thelion Length	22.02	22.55	23.34	24.04	25.25	26.67	28.20	28.70	30.65	31.78	32.57	32.57	10.55	20.20	35.40
71	Sleeve Inseam	37.79	38.47	39.54	40.54	42.29	44.28	46.31	48.15	49.25	50.00	51.34	51.34	13.55	32.60	55.30
72	Sleeve Outseam	47.91	48.66	49.81	50.85	52.62	54.64	56.71	58.63	59.81	61.16	62.09	62.09	14.18	42.10	67.80
73	Crotch Length, Omphalion	51.60	52.78	54.41	55.77	57.99	60.54	63.27	65.87	67.46	69.22	70.34	70.34	18.74	48.70	76.30

MIL-HDBK-759B

FIGURE 50. US Army women (1988): head and face measurements

MIL-HDBK-759B

No.	Measurements	Percentiles in Centimeters										Range (1st-99th)	MIN	MAX	
		1st	2nd	5th	10th	25th	50th	75th	90th	95th	98th				99th
HEAD AND FACE MEASUREMENTS															
75	Head Circumference	51.34	51.69	52.25	52.77	53.65	54.60	55.55	56.45	57.05	57.82	58.40	7.06	50.00	61.10
76	Head Length	17.23	17.38	17.63	17.87	18.29	18.74	19.16	19.53	19.75	20.01	20.19	2.96	15.80	21.10
77	Seillon-Back of Head	17.35	17.53	17.80	18.05	18.46	18.90	19.34	19.73	19.97	20.25	20.45	3.10	15.80	21.00
78	Pronasale-Back of Head	19.17	19.41	19.74	20.03	20.49	20.98	21.47	21.93	22.20	22.53	22.75	3.58	17.80	23.50
79	Ectoorbitale-Back of Head	13.92	14.09	14.35	14.57	14.94	15.35	15.76	16.14	16.36	16.60	16.75	2.83	13.20	17.20
80	Tregion-Back of Head	8.48	8.62	8.84	9.04	9.37	9.74	10.11	10.44	10.64	10.86	11.01	2.53	8.00	11.70
81	Head Breadth	13.33	13.46	13.66	13.83	14.12	14.43	14.75	15.07	15.27	15.51	15.69	2.36	12.60	16.70
82	Minimum Frontal Breadth	9.17	9.32	9.54	9.72	10.01	10.32	10.65	10.94	11.12	11.32	11.45	2.28	8.60	12.10
83	Tregion-Top of Head	10.99	11.17	11.42	11.65	12.00	12.36	12.71	13.03	13.25	13.53	13.74	2.75	10.60	14.50
84	Menton-Seillon Length	10.06	10.20	10.41	10.61	10.95	11.35	11.75	12.14	12.39	12.68	12.89	2.83	9.40	13.40
85	Bizygomatic Breadth	12.32	12.46	12.67	12.87	13.19	13.55	13.92	14.27	14.50	14.77	14.98	2.66	11.80	15.70
86	Interpupillary Breadth	5.45	5.53	5.66	5.77	5.98	6.22	6.47	6.70	6.85	7.01	7.11	1.66	5.20	7.60
87	Bitregion Coronal Arc	30.78	31.08	31.56	32.00	32.76	33.61	34.48	35.30	35.81	36.43	36.87	6.09	29.80	39.20
88	Bitregion Frontal Arc	26.45	26.74	27.17	27.54	28.13	28.78	29.43	30.06	30.45	30.92	31.25	4.80	25.00	32.00
89	Bitregion Chin Arc	27.37	27.71	28.19	28.62	29.37	30.25	31.19	32.05	32.55	33.06	33.37	6.00	26.10	35.00
90	Bitregion Submandibular Arc	24.78	25.08	25.55	25.99	26.73	27.57	28.44	29.24	29.74	30.32	30.73	5.95	23.50	32.90
91	Glabella-Back of Head	17.53	17.71	17.99	18.24	18.66	19.11	19.54	19.93	20.17	20.46	20.66	3.13	16.20	21.10
92	Subnasale-Back of Head	17.70	17.93	18.27	18.56	19.03	19.56	20.10	20.60	20.90	21.23	21.44	3.74	16.40	22.00
93	Menton-Back of Head	15.17	15.39	15.75	16.08	16.66	17.33	18.00	18.59	18.94	19.33	19.58	4.41	14.10	21.00
94	Bitregion Breadth	12.51	12.62	12.81	12.98	13.29	13.63	13.98	14.31	14.52	14.77	14.96	2.45	11.50	15.70
95	Ectoorbitale-Top of Head	9.77	9.95	10.21	10.43	10.78	11.15	11.52	11.87	12.09	12.36	12.55	2.78	9.30	13.50
96	Glabella-Top of Head	7.31	7.47	7.73	7.96	8.36	8.81	9.28	9.72	10.01	10.35	10.59	3.28	6.70	11.60
97	Seillon-Top of Head	9.04	9.21	9.47	9.70	10.09	10.51	10.95	11.38	11.65	11.98	12.22	3.18	8.10	13.30
98	Pronasale-Top of Head	12.30	12.51	12.84	13.14	13.63	14.17	14.69	15.17	15.47	15.83	16.09	3.79	11.30	16.80
99	Subnasale-Top of Head	13.50	13.71	14.04	14.32	14.79	15.29	15.78	16.22	16.49	16.82	17.05	3.55	12.80	17.90
100	Stomion-Top of Head	15.66	15.91	16.28	16.55	17.00	17.50	18.02	18.50	18.80	19.14	19.37	3.71	14.70	20.00
101	Menton-Top of Head	18.78	20.01	20.36	20.67	21.19	21.76	22.32	22.83	23.15	23.53	23.80	4.02	18.70	24.50
102	Menton-Chinon Length	15.50	15.72	16.07	16.41	16.99	17.65	18.31	18.89	19.23	19.60	19.85	4.35	14.40	20.80
103	Blocular Breadth, Maximum	10.76	10.89	11.09	11.27	11.58	11.95	12.33	12.68	12.90	13.14	13.30	2.54	10.20	14.40
104	Subnasale-Seillon Length	3.99	4.09	4.24	4.36	4.57	4.80	5.05	5.30	5.45	5.63	5.75	1.76	3.40	6.50
105	Nose Breadth	9.17	9.32	9.54	9.72	10.01	10.32	10.65	10.94	11.12	11.32	11.45	2.28	8.60	12.10

MIL-HDBK-759B

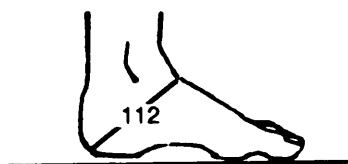
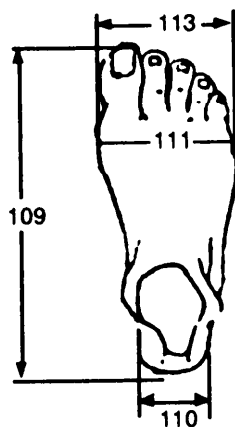
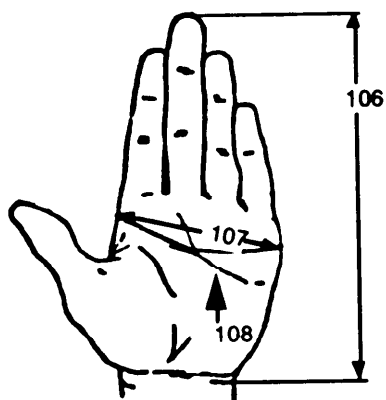

FIGURE 51. US Army women (1988): hand and foot measurements

MIL-HDBK-759B

TABLE 37. US Army women (1988): hand and foot measurements

No.	Measurements	Percentiles in Centimeters										Range			
		1st	2nd	5th	10th	25th	50th	75th	90th	95th	98th	99th	(1st-99th) MIN	MAX	
HAND MEASUREMENTS															
106	Hand Length	15.89	16.13	16.50	16.83	17.39	18.02	18.67	19.29	19.69	20.16	20.50	4.61	14.90	21.50
107	Hand Breadth	7.09	7.19	7.34	7.47	7.69	7.93	8.18	8.42	8.56	8.74	8.86	1.77	6.60	9.80
108	Hand Circumference	16.73	16.93	17.25	17.55	18.04	18.60	19.16	19.69	20.03	20.43	20.72	3.99	15.80	23.00
FOOT MEASUREMENTS															
109	Foot Length	21.69	21.98	22.44	22.86	23.60	24.43	25.28	26.03	26.46	26.92	27.22	5.53	20.30	29.00
110	Heel Breadth	5.32	5.41	5.57	5.71	5.96	6.27	6.61	6.94	7.14	7.39	7.56	2.24	5.00	8.40
111	Ball of Foot Circumference	19.76	20.06	20.51	20.92	21.59	22.33	23.08	23.79	24.23	24.76	25.13	5.37	18.50	26.20
112	Heel-Ankle Circumference	27.25	27.56	28.08	28.58	29.46	30.44	31.44	32.38	33.00	33.76	34.34	7.09	25.70	36.50
113	Foot Breadth, Horizontal	7.87	7.98	8.16	8.34	8.63	8.96	9.29	9.59	9.78	10.02	10.20	2.33	7.30	10.90

MIL-HDBK-759B

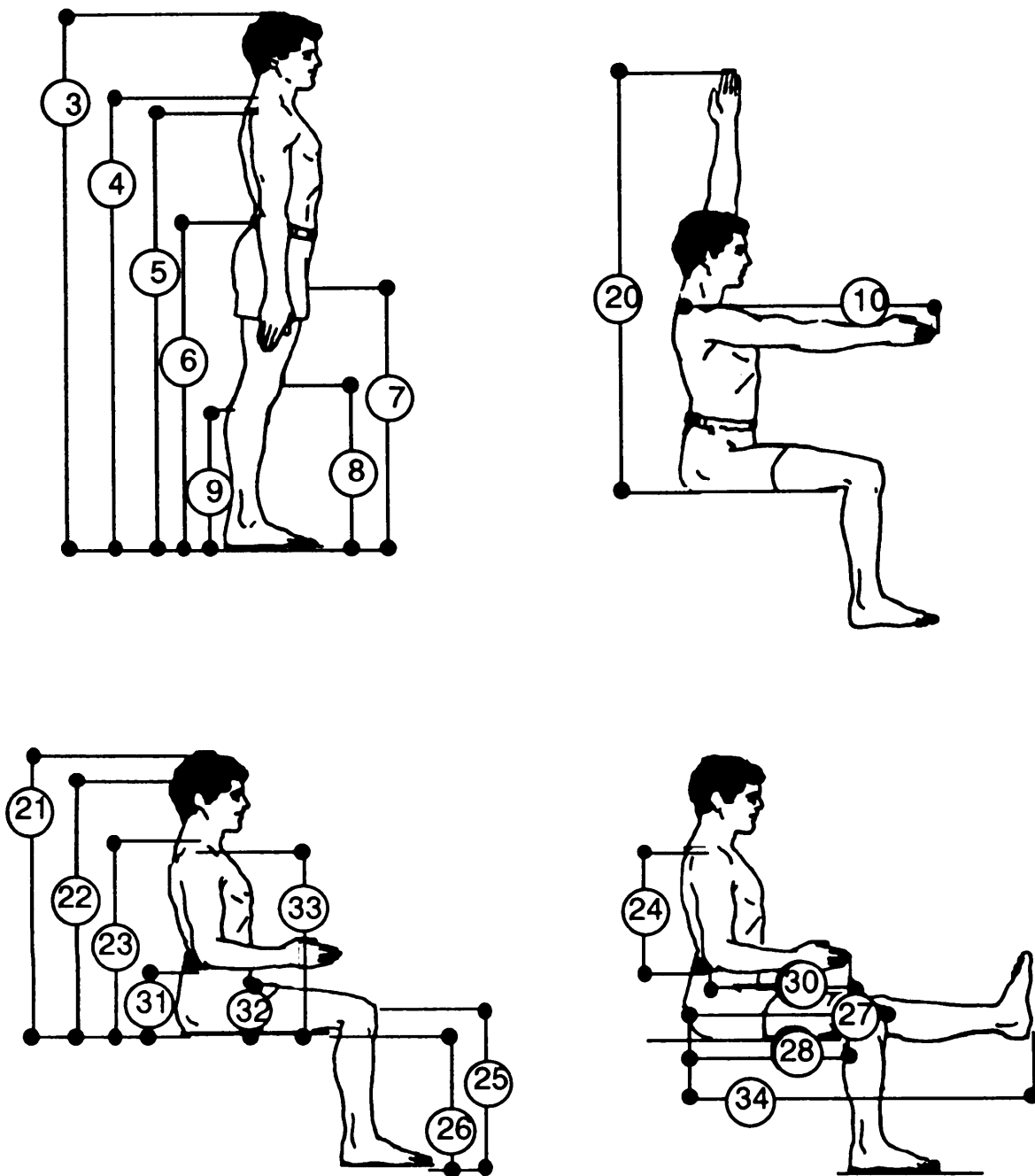

FIGURE 52. US Army male/female pilots (1988): standing and sitting measurements

MIL-HDBK-759B

TABLE 38. US Army male pilots (1988): standing and sitting measurements

No.	Measurements	Percentiles in Centimeters											Range (1st-99th)	MIN	MAX	
		1st	2nd	5th	10th	25th	50th	75th	90th	95th	98th	99th				
1	Age (years)	21.00	23.00	24.00	26.00	28.00	32.00	37.00	40.00	42.00	44.00	46.00	25.00	20.00	51.00	
2	Weight (kilograms)	59.86	62.60	64.54	67.98	73.10	79.60	86.40	92.54	97.30	101.85	103.61	43.75	56.90	113.60	
STANDING MEASUREMENTS																
3	Stature	162.02	163.35	165.94	168.56	173.20	177.20	181.10	186.00	188.36	190.07	191.04	29.02	157.90	194.10	
4	Cervicale Height	139.06	141.25	143.08	145.30	149.50	153.20	156.70	161.22	163.62	165.37	166.10	27.04	135.30	169.40	
5	Acromiale Height	131.59	132.83	135.68	137.58	141.60	145.40	149.20	153.42	155.70	157.50	158.85	27.26	127.80	162.20	
6	Wrist Height, Omphalion	95.39	96.30	98.62	100.10	103.30	106.30	109.50	113.10	114.90	115.80	117.25	21.86	93.20	120.30	
7	Crotch Height	75.62	75.70	77.40	78.60	81.20	83.90	87.00	90.10	92.06	93.02	93.82	18.20	73.00	95.50	
8	Knee Height, Midpatella	44.95	45.50	46.50	47.10	48.50	50.30	52.10	53.80	54.80	56.00	56.31	11.36	43.80	57.90	
9	Calf Height	30.99	31.20	31.90	32.60	33.90	35.00	36.40	37.80	38.50	39.35	39.82	8.83	30.80	40.80	
10	Thumbtip Reach	72.66	73.08	74.00	75.20	77.90	80.50	83.00	85.30	86.30	88.59	91.02	18.36	70.50	92.60	
SITTING MEASUREMENTS																
20	Overhead Fingertip Reach, Sitting	130.98	131.88	135.00	136.90	140.00	144.00	147.60	151.06	153.76	155.50	156.91	25.83	128.00	158.30	
21	Sitting Height	84.08	85.95	87.10	88.48	90.80	93.10	95.20	97.02	98.10	99.42	100.34	16.26	81.90	102.10	
22	Eye Height, Sitting	71.29	73.78	75.30	76.78	79.00	81.10	83.20	85.20	86.14	87.25	88.52	17.23	70.70	90.30	
23	Mid-Shoulder Height	56.56	58.18	59.70	60.60	62.50	64.30	66.10	67.70	68.50	69.62	70.65	14.09	54.70	72.30	
24	Shoulder-Elbow Length	33.18	33.75	34.30	34.90	36.00	37.10	38.40	39.50	40.00	40.95	41.50	8.32	32.50	42.50	
25	Knee Height, Sitting	50.15	50.80	51.90	52.50	54.10	55.70	57.70	59.40	60.60	61.35	62.00	11.85	48.80	63.20	
26	Popliteal Height	37.78	38.58	39.64	40.40	41.70	43.10	44.60	46.50	47.46	48.30	48.91	11.13	36.70	49.50	
27	Buttock-Knee Length	56.09	56.88	57.70	58.48	60.10	61.70	63.60	65.50	66.46	67.55	68.06	11.97	55.70	70.60	
28	Buttock-Popliteal Length	45.34	45.80	46.34	47.30	48.50	50.00	51.80	53.52	54.96	55.82	56.36	11.02	44.40	57.70	
30	Forearm-Hand Length	44.18	44.50	45.08	45.80	47.00	48.40	49.80	51.00	51.80	52.72	53.20	9.02	42.50	54.50	
31	Elbow Rest Height	18.23	18.85	19.94	21.00	22.70	24.30	25.70	27.40	28.36	29.62	30.21	11.98	15.60	31.10	
32	Thigh Clearance	14.46	14.50	14.90	15.40	16.00	16.80	17.50	18.20	18.66	19.00	19.32	4.86	13.60	20.90	
33	Acromiale Height, Sitting	53.65	55.15	56.44	57.40	59.40	61.40	63.20	64.92	65.56	66.74	68.01	14.36	52.30	69.60	
34	Functional Leg Length	99.15	99.70	100.94	102.70	105.40	108.70	112.03	115.00	117.10	118.60	119.71	20.56	98.10	122.50	

MIL-HDBK-759B

TABLE 39. US Army female pilots (1989): standing and sitting measurements

No.	Measurements	Percentiles in Centimeters											Range (1st-99th)	MIN	MAX	
		1st	2nd	5th	10th	25th	50th	75th	90th	95th	98th	99th				
1	Age (years)	21.00	21.00	23.00	25.00	26.00	28.00	33.00	36.50	39.00	41.00	43.30	22.30	20.00	45.00	
2	Weight (kilograms)	47.27	49.48	52.15	55.25	59.50	65.00	70.63	76.80	81.13	85.92	91.39	44.12	46.40	96.70	
STANDING MEASUREMENTS																
3	Stature	157.41	158.34	160.90	162.80	165.30	167.60	170.80	173.85	175.68	178.26	178.77	21.36	156.20	187.00	
4	Cervicale Height	136.34	137.37	139.15	140.20	142.40	145.00	148.05	151.00	152.25	154.23	156.00	19.66	135.50	164.30	
5	Acromiale Height	128.71	130.17	131.3	132.70	134.90	137.45	140.53	143.00	144.38	146.41	148.87	20.16	126.70	156.50	
6	Waist Height, Omphalion	93.84	94.85	96.28	97.10	98.80	101.20	103.30	105.80	107.15	108.76	110.69	16.85	92.00	114.50	
7	Crotch Height	75.07	75.20	75.50	76.00	77.10	78.65	80.90	82.90	83.85	87.70	87.69	12.62	75.00	89.80	
8	Knee Height, Mictetella	43.87	44.17	44.80	45.20	45.90	47.00	48.20	49.45	50.30	51.33	51.90	8.03	43.10	53.80	
9	Calf Height	28.44	28.60	29.30	30.00	30.80	31.80	33.03	34.40	35.13	35.93	36.80	8.36	27.60	38.90	
10	Thumbtip Reach	70.30	70.50	71.10	71.70	73.10	74.90	76.50	78.45	79.73	80.56	82.65	12.35	69.10	83.70	
SITTING MEASUREMENTS																
20	Overhead Fingertip Reach, Sitting	127.04	127.77	129.68	131.30	133.50	136.00	139.03	141.60	143.28	145.70	146.90	19.86	123.70	149.00	
21	Sitting Height	81.21	82.52	83.68	84.50	86.58	88.30	90.03	92.00	92.70	94.20	95.20	13.99	80.00	97.10	
22	Eye Height, Sitting	70.31	71.44	72.20	73.00	75.00	77.00	78.70	80.15	81.20	82.53	83.58	13.27	69.10	85.40	
23	Mid-Shoulder Height	55.18	55.84	57.00	57.70	59.10	60.70	62.20	63.30	64.50	64.90	65.90	10.72	54.40	69.40	
24	Shoulder-Elbow Length	32.20	32.50	33.00	33.30	33.70	34.40	35.40	36.40	36.80	37.53	38.10	5.90	32.10	38.40	
25	Knee Height, Sitting	4.95	48.77	50.30	50.80	51.60	52.65	53.80	55.10	56.00	56.99	57.30	52.35	48.40	60.00	
26	Popliteal Height	36.64	37.14	37.70	38.00	38.90	40.00	41.10	42.20	42.80	43.63	44.53	7.89	36.30	45.80	
27	Buttock-Knee Length	55.58	56.20	56.80	57.50	58.40	59.90	61.73	62.70	63.60	64.20	64.37	8.79	54.60	67.90	
28	Buttock-Popliteal Length	45.04	45.58	46.30	47.00	47.80	49.15	50.63	51.60	52.33	52.93	53.17	8.13	44.50	55.50	
30	Forearm-Hand Length	42.11	42.80	43.08	43.30	43.90	44.70	45.70	46.90	47.63	48.19	48.83	6.72	41.90	51.20	
31	Elbow Rest Height	17.54	17.80	19.65	20.50	21.90	23.30	24.80	26.00	26.63	28.60	29.07	11.53	14.40	30.00	
32	Thigh Clearance	13.44	13.60	14.08	14.40	15.00	15.85	16.80	17.60	18.13	18.98	19.63	6.19	12.90	20.60	
33	Acromiale Height, Sitting	51.64	52.74	54.08	54.70	56.40	57.90	59.40	60.90	61.85	62.66	63.03	11.39	50.90	66.40	
34	Functional Leg Length	96.77	97.40	99.05	100.05	101.40	103.60	105.70	108.70	109.80	111.13	112.07	15.30	96.00	115.20	

MIL-HDBK-759B

This Page Intentionally Left Blank.

MIL-HDBK-759B

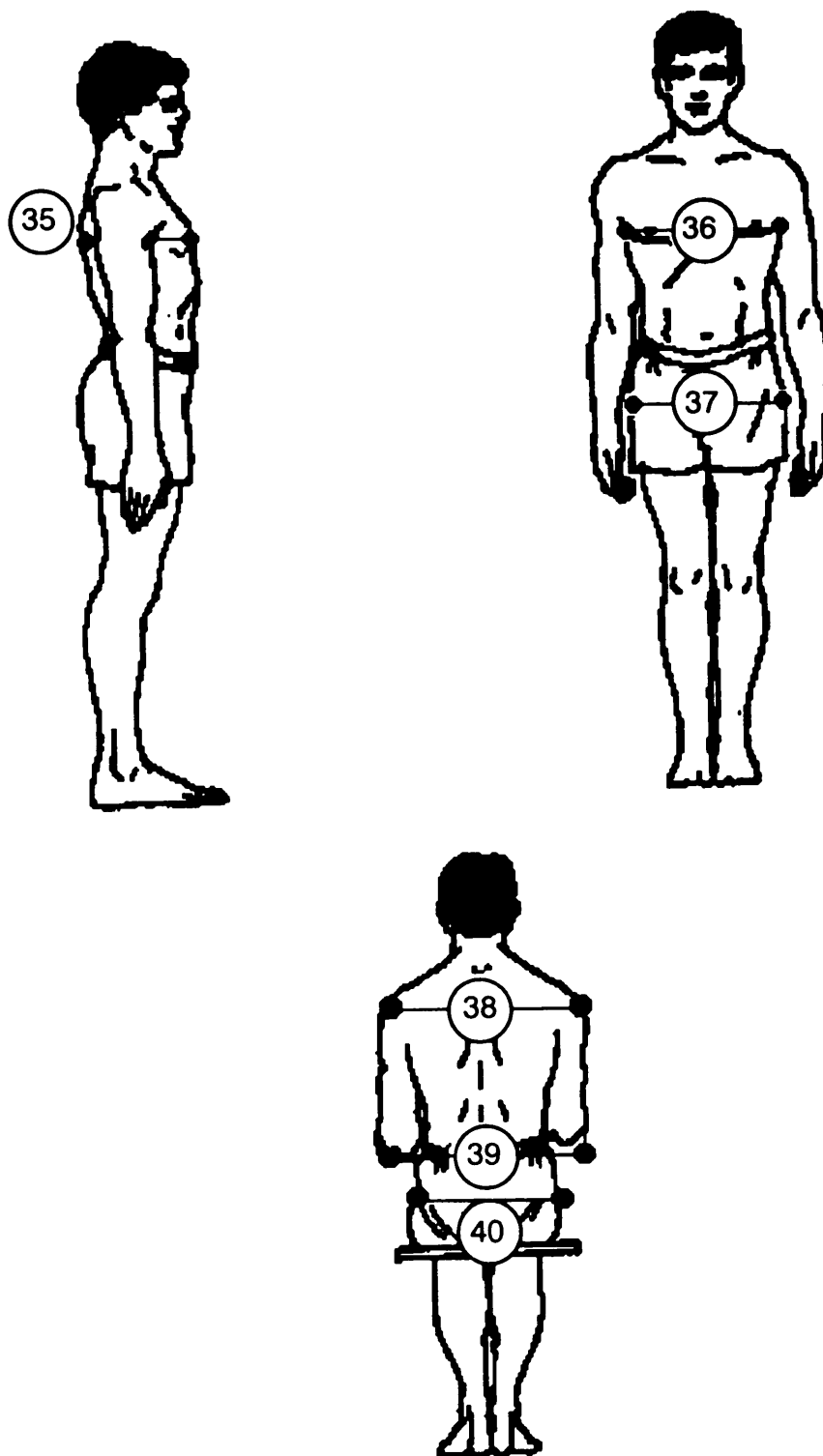

FIGURE 53. US Army male/female pilots(1988): breadth and joint breadths, bone

MIL-HDBK-759B

TABLE 40. US Army male pilots (1988): breadth and joint breadths, bone

No.	Measurements	Percentiles in Centimeters											Range (1st-99th)	MIN	MAX	
		1st	2nd	5th	10th	25th	50th	75th	90th	95th	98th	99th				
BREADTH MEASUREMENTS																
35	Chest Depth	20.96	21.30	21.74	22.40	23.60	25.00	26.30	27.60	28.40	29.02	29.41	8.45	18.80	31.90	
36	Chest Breadth	28.39	29.00	29.74	30.50	31.50	33.10	34.60	36.20	36.76	37.85	38.72	10.33	26.00	39.80	
37	Hip Breadth, Standing	31.18	31.50	32.20	32.50	33.50	34.80	36.20	37.40	37.96	38.92	39.50	8.32	30.60	42.80	
38	Bideitold Breadth	43.69	45.03	46.00	46.68	48.00	49.50	51.20	52.50	53.36	54.37	55.07	11.38	42.80	57.30	
39	Forearm-Forearm Breadth	46.95	48.00	49.24	50.20	52.90	55.50	58.00	60.22	62.30	64.12	67.41	20.46	44.60	71.10	
40	Hip Breadth, Sitting	32.88	33.08	33.80	34.50	35.70	37.10	38.50	40.20	41.00	41.92	42.60	9.72	31.90	45.30	

TABLE 41. US Army female pilots (1988): breadth and joint breadths, bone

No.	Measurements	Percentiles in Centimeters											Range (1st-99th)	MIN	MAX	
		1st	2nd	5th	10th	25th	50th	75th	90th	95th	98th	99th				
BREADTH MEASUREMENTS																
35	Chest Depth	19.50	19.84	20.70	21.30	22.70	24.10	25.93	27.35	28.20	30.23	31.26	11.76	17.40	32.50	
36	Chest Breadth	24.80	25.04	25.70	26.30	27.50	28.70	30.10	31.45	32.23	33.33	34.94	10.14	22.50	37.50	
37	Hip Breadth, Standing	30.48	31.00	31.95	32.80	34.10	35.70	37.10	38.30	39.23	40.09	40.83	10.35	29.80	41.50	
38	Bideitold Breadth	38.31	39.17	40.30	41.20	42.48	43.90	45.30	46.70	47.63	48.60	48.90	10.59	37.50	53.20	
39	Forearm-Forearm Breadth	39.00	39.87	42.38	43.65	45.80	47.85	50.20	52.50	54.15	56.39	57.33	18.33	37.30	60.70	
40	Hip Breadth, Sitting	33.54	34.44	35.48	36.20	37.80	39.80	41.70	43.40	44.63	45.79	46.33	12.79	32.60	47.50	

MIL-HDBK-759B

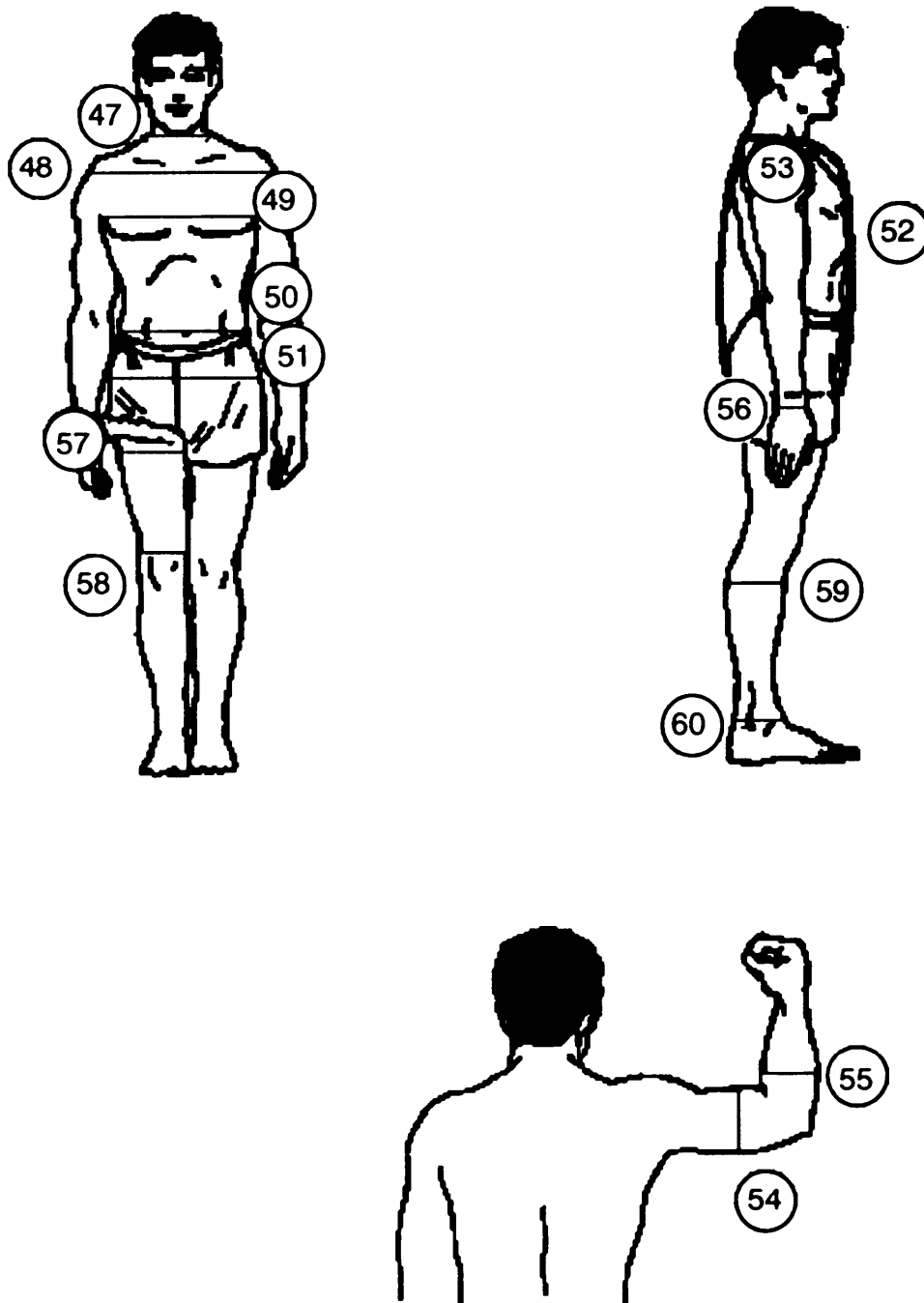

FIGURE 54. US Army male/female pilots(1988): circumference measurements

MIL-HDBK-759B

TABLE 42. US Army male pilots (1988): circumference measurements

No.	Measurements	Percentiles in Centimeters										Range (1st-99th)	MIN	MAX	
		1st	2nd	5th	10th	25th	50th	75th	90th	95th	98th				99th
CIRCUMFERENCES															
47	Neck Circumference	34.38	34.68	35.24	35.80	36.80	37.80	39.20	40.50	41.20	41.90	42.50	8.12	33.40	42.90
48	Shoulder Circumference	104.84	107.28	109.60	110.80	113.50	117.20	121.10	124.30	126.42	128.70	130.21	25.37	100.90	132.90
49	Chest Circumference	87.54	88.76	91.58	93.10	96.90	100.70	105.10	108.22	110.96	113.57	115.47	27.93	85.00	119.40
50	Waist Circumference, Omphalion	72.76	74.48	76.74	79.08	83.30	88.90	94.10	99.00	101.70	104.17	105.82	33.06	69.00	119.00
51	Buttock Circumference	87.03	89.18	90.50	92.30	95.30	98.80	102.80	106.32	109.42	110.35	111.34	24.31	84.90	120.00
52	Vert. Trunk Circumference, Standing	149.77	151.58	154.54	156.70	161.00	165.30	170.40	174.60	177.18	179.54	182.06	34.29	137.80	184.80
LIMB CIRCUMFERENCES															
Percentiles in Centimeters															
53	Scye Circumference	39.49	40.10	40.80	41.90	43.10	44.50	46.20	47.72	48.50	49.62	50.50	11.01	38.40	51.00
54	Biceps Circumference	27.74	28.65	29.90	30.50	32.00	33.40	35.00	36.30	37.50	38.22	39.21	11.47	26.50	41.50
55	Forearm Circumference, Flexed	26.00	26.73	27.34	28.00	28.80	30.00	31.00	32.20	32.90	33.52	34.21	8.21	25.10	36.00
56	Wrist Circumference	15.79	15.98	16.20	16.40	16.90	17.40	17.90	18.30	18.60	19.12	19.21	3.42	14.80	19.90
57	Thigh Circumference	49.88	50.65	52.54	53.90	56.70	59.40	62.00	65.00	66.70	67.95	69.50	19.62	46.60	78.20
58	Lower Thigh Circumference	34.09	34.63	35.34	36.00	37.20	39.00	40.70	42.30	43.20	44.37	44.81	10.72	33.20	45.90
59	Calf Circumference	33.09	33.28	34.24	34.90	36.20	37.50	39.30	40.80	41.56	42.62	43.31	10.22	30.00	44.80
60	Ankle Circumference	19.59	19.80	20.24	20.60	21.20	22.00	23.00	23.70	24.26	24.72	25.00	5.41	18.80	25.40

MIL-HDBK-759B

TABLE 43. US Army female pilots (1988): circumference measurements

No.	Measurements	Percentiles in Centimeters											Range (1st-99th)	MIN	MAX	
		1st	2nd	5th	10th	25th	50th	75th	90th	95th	98th	99th				
CIRCUMFERENCES																
47	Neck Circumference	28.34	28.74	29.30	29.95	30.70	31.60	32.80	33.75	34.50	35.56	36.66	8.32	27.20	37.20	
48	Shoulder Circumference	92.92	93.87	95.70	98.10	100.68	103.90	107.30	111.10	113.73	115.12	117.02	24.10	89.70	126.10	
49	Chest Circumference	77.02	79.40	82.28	83.95	87.88	92.00	96.50	101.25	103.53	108.30	113.75	36.73	75.20	117.60	
50	Waist Circumference, Omphalion	66.04	66.87	68.73	70.85	74.98	80.60	87.13	94.40	97.39	102.21	105.42	39.38	64.00	109.90	
51	Buttock Circumference	84.61	86.69	88.70	90.80	94.40	98.70	102.95	106.60	109.38	112.53	113.39	28.78	83.50	115.10	
52	Vert. Trunk Circumference, Standing	143.15	146.04	147.78	150.30	153.45	157.35	162.00	165.65	168.53	172.57	175.50	32.35	141.90	177.30	
LIMB CIRCUMFERENCES																
53	Scye Circumference	32.90	33.44	34.50	35.30	36.38	37.80	39.50	41.00	42.20	43.70	43.93	11.03	32.30	45.20	
54	Biceps Circumference, Flexed	23.00	23.67	24.70	25.30	26.60	28.00	29.70	31.70	32.73	33.20	34.06	11.06	22.50	37.10	
55	Forearm Circumference, Flexed	22.04	22.34	23.08	23.65	24.40	25.40	26.40	27.50	28.00	28.93	29.33	7.29	21.50	32.50	
56	Wrist Circumference	13.94	14.10	14.40	14.50	14.80	15.30	15.80	16.20	16.30	16.70	16.80	2.88	13.60	17.40	
57	Thigh Circumference	48.40	49.57	51.43	53.25	55.65	58.55	61.40	64.65	67.55	69.40	70.95	22.55	48.00	72.60	
58	Lower Thigh Circumference	32.81	33.31	33.78	34.65	36.28	37.90	40.00	41.95	43.05	44.96	46.10	13.29	32.30	47.20	
59	Calf Circumference	30.44	30.90	32.00	32.80	34.08	35.85	37.50	39.00	39.60	40.60	41.43	10.99	29.80	45.90	
60	Ankle Circumference	18.44	18.70	19.08	19.50	20.20	20.90	21.60	22.40	22.80	23.63	23.80	5.36	18.00	24.30	

MIL-HDBK-759B

This Page Intentionally Left Blank.

MIL-HDBK-759B

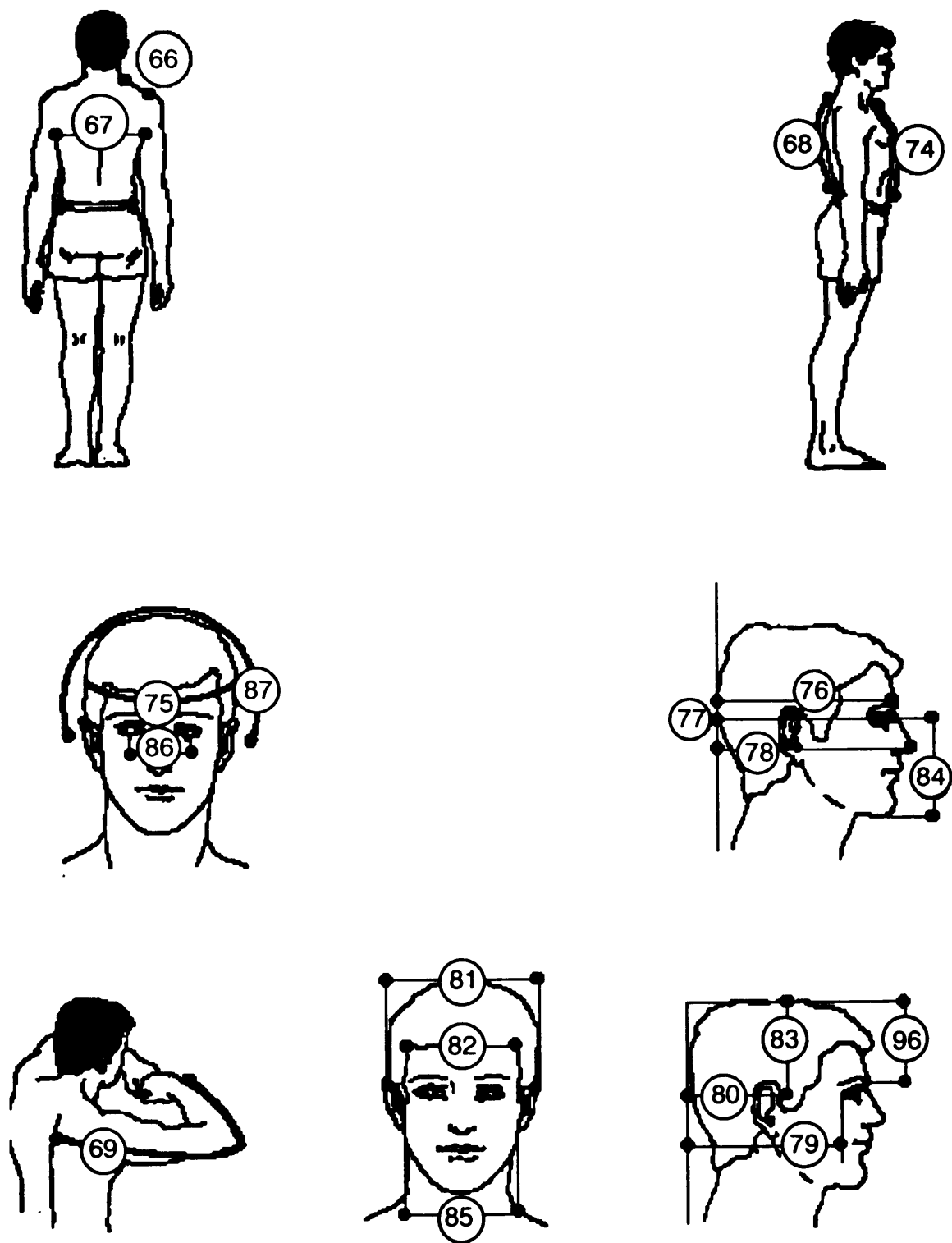

FIGURE 55. US Army male/female pilots (1988): surface, head and face measurements

MIL-HDBK-759B

TABLE 44. US Army male pilots (1988): surface, head and face measurements

No.	Measurements	Percentiles in Centimeters													MIN	MAX
		1st	2nd	5th	10th	25th	50th	75th	90th	95th	98th	99th	Range (1st-99th)			
SURFACE MEASUREMENTS																
66	Shoulder Length	13.09	13.40	13.80	14.10	14.80	15.40	16.20	16.72	17.10	17.52	17.72	4.63	12.70	18.40	
67	Interscye I	34.74	35.08	36.24	37.18	38.70	40.90	42.70	44.32	45.70	46.80	47.56	12.82	33.80	50.20	
68	Waist Back Length, Omphalion	43.00	44.00	44.70	45.50	47.10	48.80	50.30	51.90	52.80	53.82	54.54	11.54	41.30	55.40	
69	Sleeve Length, Spine-Wrist	82.00	82.35	83.70	84.90	87.20	89.50	91.80	94.12	95.66	97.20	98.06	16.06	79.60	100.20	
74	Waist Front Length, Omphalion	37.07	38.00	38.44	39.10	40.60	42.00	43.40	44.70	45.60	46.62	47.42	10.35	34.10	48.80	
HEAD AND FACE MEASUREMENTS																
75	Head Circumference	53.99	54.40	54.80	55.20	56.10	57.00	58.10	58.80	59.20	59.82	60.20	6.21	53.60	60.60	
76	Head Length	18.29	18.49	18.80	19.10	19.50	19.90	20.30	20.70	20.90	21.20	21.31	3.02	17.70	21.90	
77	Seillon-Back of Head	18.09	18.47	18.77	18.98	19.41	19.80	20.22	20.61	20.86	21.06	21.27	3.18	17.66	21.59	
78	Pronasale-Back of Head	20.15	20.59	20.87	21.12	21.56	22.08	22.52	22.95	23.19	23.54	23.72	3.57	19.51	23.92	
79	Ecto-orbitale-Back of Head	14.73	14.86	15.14	15.33	15.60	16.00	16.36	16.77	17.04	17.25	17.31	2.58	14.03	17.51	
80	Tregion-Back of Head	8.74	8.87	9.07	9.21	9.48	9.84	10.22	10.57	10.77	11.00	11.15	2.41	8.28	11.34	
81	Head Breadth	14.19	14.30	14.50	14.70	15.00	15.30	15.70	16.00	16.30	16.60	16.80	2.61	14.00	17.10	
82	Minimum Frontal Breadth	9.30	9.50	9.68	9.85	10.14	10.46	10.80	11.09	11.27	11.50	11.75	2.45	9.16	12.27	
83	Tregion-Top of Head	11.74	11.87	12.14	12.32	12.67	13.03	13.42	13.77	13.93	14.21	14.43	2.69	11.48	14.98	
84	Merion-Seillon Length	10.90	11.00	11.20	11.50	11.80	12.20	12.60	13.06	13.33	13.60	13.81	2.91	10.70	14.20	
85	Elzygomatic Breadth	12.90	13.10	13.30	13.50	13.80	14.20	14.50	14.80	15.10	15.30	15.41	2.51	12.50	15.80	
86	Interpupillary Breadth	5.70	5.80	5.90	6.00	6.20	6.40	6.60	6.90	7.00	7.10	7.20	1.50	5.60	7.50	
87	Bitregion-Coronal Arc	32.40	32.79	33.27	33.70	34.40	35.20	36.15	36.96	37.30	37.91	38.31	5.91	31.90	39.80	
96	Glabella-Top of Head	8.19	8.37	8.63	8.86	9.28	9.70	10.15	10.58	10.80	11.18	11.25	3.06	7.90	12.10	

MIL-HDBK-759B

TABLE 45. US Army female pilots (1988): surface, head and face measurements

No.	Measurements	Percentiles in Centimeters											Range (1st-99th)	MIN	MAX	
		1st	2nd	5th	10th	25th	50th	75th	90th	95th	98th	99th				
SURFACE MEASUREMENTS																
66	Shoulder Length	11.97	12.37	12.78	13.40	13.98	14.60	15.40	16.10	16.53	17.00	17.27	5.30	11.70	16.20	
67	Interscye I	29.46	30.72	31.50	32.25	34.00	35.50	37.60	39.40	40.03	41.93	42.63	13.17	28.60	43.40	
68	Waist Back Length, Omphalion	41.24	41.91	42.45	42.90	44.10	45.60	47.30	48.65	49.73	50.43	51.47	10.23	41.00	55.50	
69	Sleeve Length, Spine-Wrist	77.54	78.20	78.75	79.30	80.80	82.40	84.40	85.60	86.90	88.10	88.63	11.09	77.00	92.20	
74	Waist Front Length, Omphalion	35.22	36.10	37.00	37.40	38.70	40.10	41.60	43.30	44.43	45.58	46.13	10.91	34.20	48.10	
HEAD AND FACE MEASUREMENTS																
75	Head Circumference	51.17	51.57	52.60	53.15	53.98	54.75	55.80	56.30	56.80	57.23	58.18	7.01	50.50	58.70	
76	Head Length	17.14	17.37	17.60	18.00	18.40	18.80	19.30	19.60	19.80	20.10	20.20	3.06	16.50	20.50	
77	Sellion-Back of Head	17.23	17.59	17.94	18.16	18.59	19.01	19.43	19.80	20.03	20.33	20.37	3.14	16.48	20.45	
78	Pronasale-Back of Head	18.96	19.41	19.92	20.14	20.64	21.11	21.56	22.00	22.28	22.57	22.77	3.81	18.29	22.88	
79	Ectoorbitale-Back of Head	13.72	14.00	14.43	14.70	14.95	15.35	15.71	16.13	16.33	16.55	16.69	2.97	13.17	16.83	
80	Tragion-Back of Head	8.17	8.50	8.79	8.94	9.33	9.75	10.12	10.44	10.62	10.93	11.22	3.05	7.99	11.57	
81	Head Breadth	13.24	13.60	13.80	13.90	14.20	14.50	14.80	15.10	15.30	15.50	15.70	2.46	12.90	16.70	
82	Minimum Frontal Breadth	9.20	9.34	9.53	9.73	10.02	10.34	10.66	10.87	11.04	11.27	11.47	2.27	8.88	11.87	
83	Tragion-Top of Head	11.17	11.25	11.62	11.89	12.12	12.44	12.80	13.17	13.45	13.72	13.92	2.75	11.00	14.52	
84	Menton-Sellion Length	9.97	10.27	10.50	10.70	11.00	11.40	11.80	12.20	12.53	12.90	13.10	3.13	9.50	13.20	
85	Bizygomatic Breadth	11.97	12.20	12.30	12.50	12.80	13.10	13.50	13.70	14.00	14.40	14.47	2.50	11.70	14.80	
86	Interpupillary Breadth	5.40	5.40	5.60	5.75	5.90	6.10	6.30	6.50	6.60	6.70	6.83	1.43	5.30	6.90	
87	Bitragion-Coronal Arc	30.94	31.10	31.70	32.30	33.00	33.70	34.60	35.30	35.83	36.63	37.23	6.29	30.6	38.00	
96	Glabella-Top of Head	7.36	7.53	7.83	7.99	8.36	8.81	9.28	9.74	10.05	10.40	10.72	3.36	7.25	11.00	

MIL-HDBK-759B

This Page Intentionally Left Blank.

MIL-HDBK-759B

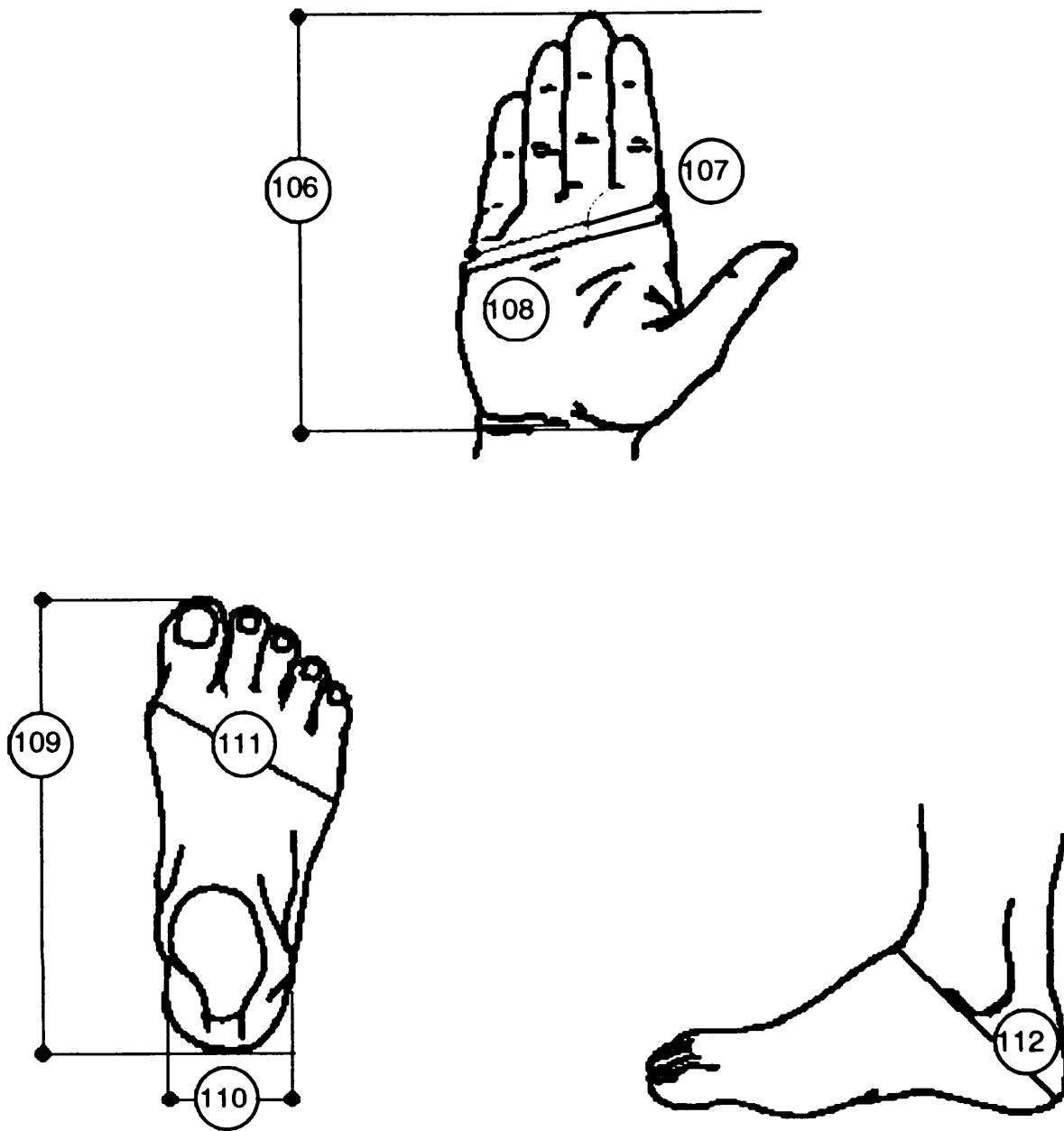

FIGURE 56. US Army male/female pilots(1988): hand and foot measurements

MIL-HDBK-759B

TABLE 46. US Army male pilots (1988): hand and foot measurements

No.	Measurements	Percentiles in Centimeters											Range		
		1st	2nd	5th	10th	25th	50th	75th	90th	95th	98th	99th	(1st-99th)	MIN	MAX
HAND MEASUREMENTS															
106	Hand Length	17.59	17.80	18.10	18.30	18.90	19.40	20.05	20.50	20.90	21.20	21.4	3.61	16.80	21.80
107	Hand Breadth	8.20	8.20	8.37	8.50	8.70	9.00	9.30	9.50	9.70	9.91	10.00	1.80	8.00	10.20
108	Hand Circumference	19.39	19.60	19.90	20.30	20.80	21.40	22.00	22.50	22.83	23.51	23.71	4.32	19.20	24.10
FOOT MEASUREMENTS															
109	Foot Length	24.19	24.48	25.00	25.38	26.10	26.80	27.60	28.40	28.90	29.50	29.80	5.61	23.50	31.10
110	Heel Breadth	5.90	6.00	6.10	6.30	6.50	6.80	7.00	7.30	7.50	7.80	7.81	1.91	5.50	8.10
111	Ball of Foot Circumference	22.40	22.68	23.10	23.48	24.00	24.80	25.50	26.40	26.90	27.50	27.91	5.51	21.50	28.00
112	Heel-Ankle Circumference	30.60	30.80	31.30	31.80	32.70	33.60	34.70	35.60	36.40	36.90	37.31	6.71	30.30	37.70

TABLE 47. US Army female pilots (1988): hand and foot measurements

No.	Measurements	Percentiles in Centimeters											Range		
		1st	2nd	5th	10th	25th	50th	75th	90th	95th	98th	99th	(1st-99th)	MIN	MAX
HAND MEASUREMENTS															
106	Hand Length	16.74	16.90	17.18	17.40	17.78	18.20	18.70	19.20	19.50	19.90	20.13	3.39	16.30	21.50
107	Hand Breadth	7.34	7.40	7.50	7.60	7.80	8.00	8.30	8.50	8.63	8.76	9.00	1.66	7.20	9.60
108	Hand Circumference	17.24	17.40	17.60	17.80	18.30	18.80	19.30	19.90	20.10	20.50	21.00	3.76	17.20	21.90
FOOT MEASUREMENTS															
109	Foot Length	22.84	23.00	23.20	23.70	24.10	24.70	25.40	26.20	26.50	26.80	27.07	4.23	22.60	27.40
110	Heel Breadth	5.40	5.50	5.60	5.70	6.00	6.20	6.40	6.70	6.90	7.13	7.20	1.80	5.30	7.40
111	Ball of Foot Circumference	20.30	20.70	21.00	21.30	21.90	22.70	23.30	24.00	24.40	24.83	25.07	4.77	20.10	26.20
112	Heel-Ankle Circumference	28.10	28.57	28.90	29.30	29.90	30.60	31.50	32.30	32.70	33.40	33.86	5.76	27.60	35.00

MIL-HDBK-759B

This Page Intentionally Left Blank.

MIL-HDBK-759B

5.3.2.4 Other data.

5.3.2.4.1 Specialized users. Where equipment will be used partly or entirely by selected or specialized segments of the military population (tank crews, aviators) or by foreign military personnel, design and sizing criteria should be based on the most appropriate anthropometric data available for these specialized populations.

5.3.2.4.2 Selected clothed dimensions.

5.3.2.4.2.1 Arctic clothed. Figure 57 and Table 48 provide selected dimensions of the 5th and 95th percentile male population attired in arctic clothing. The clothing worn is as follows:

Underwear

Undershirt, man's cotton, short sleeve
Drawers, man's cotton, shorts (boxer)
Undershirt, lightweight

Headgear

Helmet, steel, with liner
Cap, field, insulating
Hood, field, insulating

Body Clothing

Coat, man's, shell
Trousers, man's, shell
Liner, CBR, protective, coat, man's shell
Liner, CBR, protective, trousers, man's, shell
Shirt, man's cotton
Suspenders, trousers, rubber
Liner, cold-wet, coat, man's, shell
Liner, cold-wet, trousers, man's, shell
Overgarment, man's, cold-dry, upper body
Overgarment, man's, cold-dry, lower body
Liner, cold-dry, overgarment, man's, upper body
Liner, cold-dry, overgarment, man's, lower body
Vest, armored

Handgear

Mittens, lightweight, cold-dry

Footgear

Socks, men's, wool, cushion sole
Boots, combat, cold-dry (white)

5.3.2.4.2.2 Clothed body dimensions. Table 49 provides selected dimensions of the 5th and 95th percentile male population attired in the basic uniform.

5.3.2.4.2.3 Helmet Dimensions.

Personal Armor System Ground Troops (PASGT) Helmet data is provided on Figure 58.

MI Helmet data is provided on Figure 59.

DH 132 Combat Vehicle Crewman Helmet data is provided on Figure 60.

SPH 4 Aircrewman Helmet data is provided on Figure 61.

5.3.2.4.2.4 Gloved Hand Dimensions. Dimensions of the 95th percentile male gloved hand are provided on Figure 62.

MIL-HDBK-759B

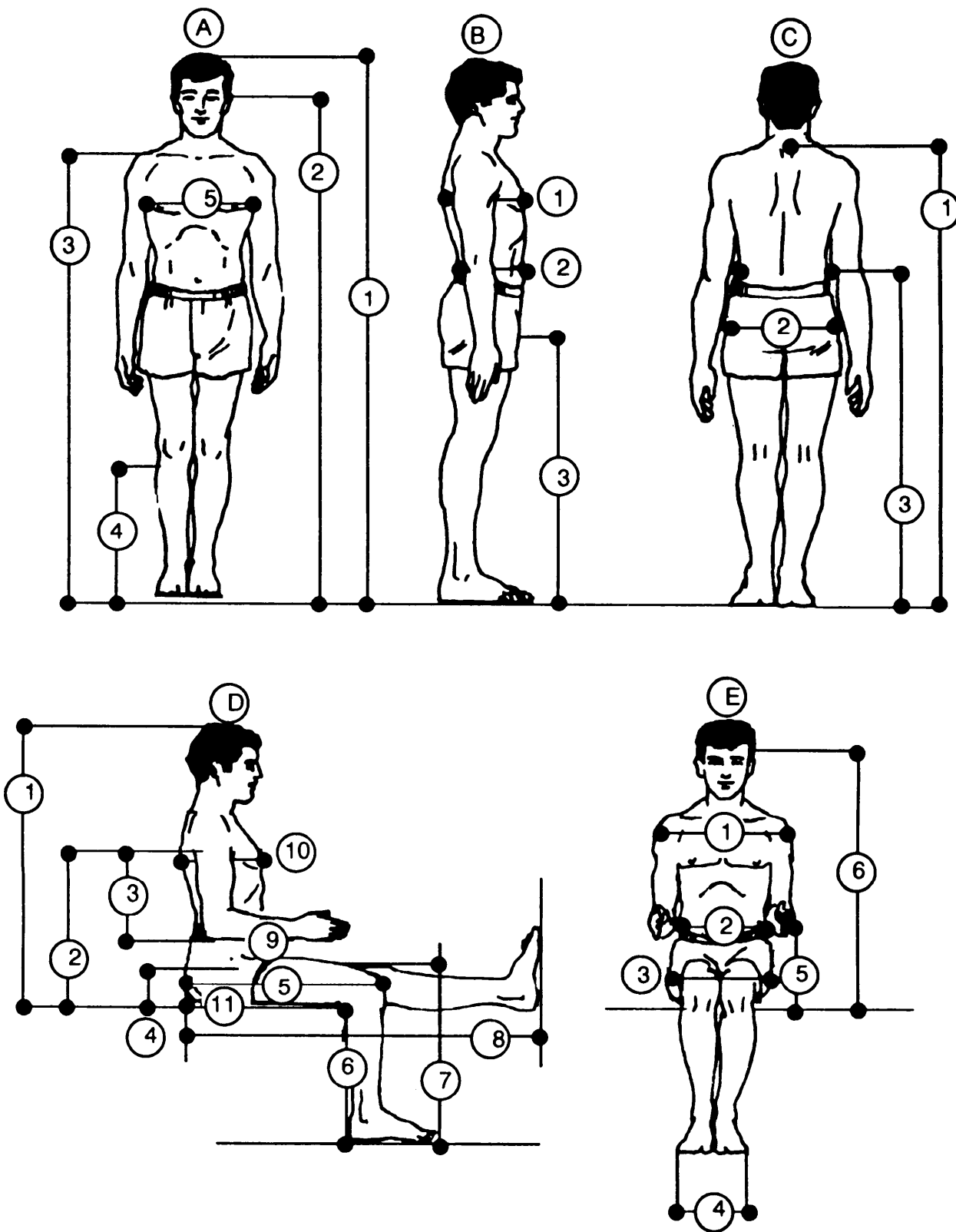

FIGURE 57. Body dimensions

MIL-HDBK-759B

TABLE 48. Body dimensions measurements, including arctic clothing¹

		Percentiles in Centimeters			
		5th Nude	Arctic Clothed ²	95th Nude	Arctic Clothed
Weight (kg)		57.3	69	91.6	106.1
Standing					
A.	1. Stature	163.8	171.4	186.0	192.5
	2. Eye Height	152.1	155.9	172.9	175.8
	3. Shoulder Height	133.6	138.0	154.2	158.0
	4. Kneecap Height	47.7	51.3	58.5	63.0
	5. Chest Breadth	27.4	45.0	34.3	45.0
B.	1. Chest Depth	20.0	30.0	26.7	32.0
	2. Waist Depth	18.0	25.0	24.0	35.5
	3. Crotch Height	76.0	71.6	92.0	83.0
C.	1. Cervical Height	139.2	145.0	160.0	163.5
	2. Hip Breadth	30.2	39.5	37.0	46.2
	3. Waist Height	97.5	103.0	115.3	118.6
Seated					
D.	1. Sitting Height	84.6	88.0	97.0	101.5
	2. Mid-Shoulder Height	57.2	58.5	67.8	69.3
	3. Shoulder-Elbow Length	33.7	37.3	40.0	42.0
	4. Thigh Clearance Height	12.2	16.5	17.0	19.0
	5. Buttock-Knee Length	54.8	60.0	64.3	67.3
	6. Back of Knee Height (Popliteal Height)	40.5	40.0	50.0	45.5
	7. Knee Height	49.8	56.4	58.6	64.0
	8. Buttock-Leg Length	100.0	109.0	117.0	125.0
	9. Elbow-Fingertip Height	44.2	54.4	51.8	34.8
	10. Chest Depth	20.0	33.3	26.7	34.8
	11. Buttock-Popliteal Length	46.0	43.7	54.6	52.0
E.	1. Shoulder Breadth	41.4	47.5	49.8	56.0
	2. Maximum Forearm-Forearm Breadth	39.9	59.5	53.6	70.6
	3. Hip Breadth, Sitting	30.7	41.1	38.4	48.8
	4. Breadth of Both Feet	19.3	24.4	21.6	26.4
	5. Elbow Rest Height	17.5	16.3	28.0	27.2
	6. Eye Height	72.6	74.7	84.6	85.8

¹Based on US Army Men, 1966²See 5.3.2.4.2 for Arctic Clothing Ensemble.

MIL-HDBK-759B

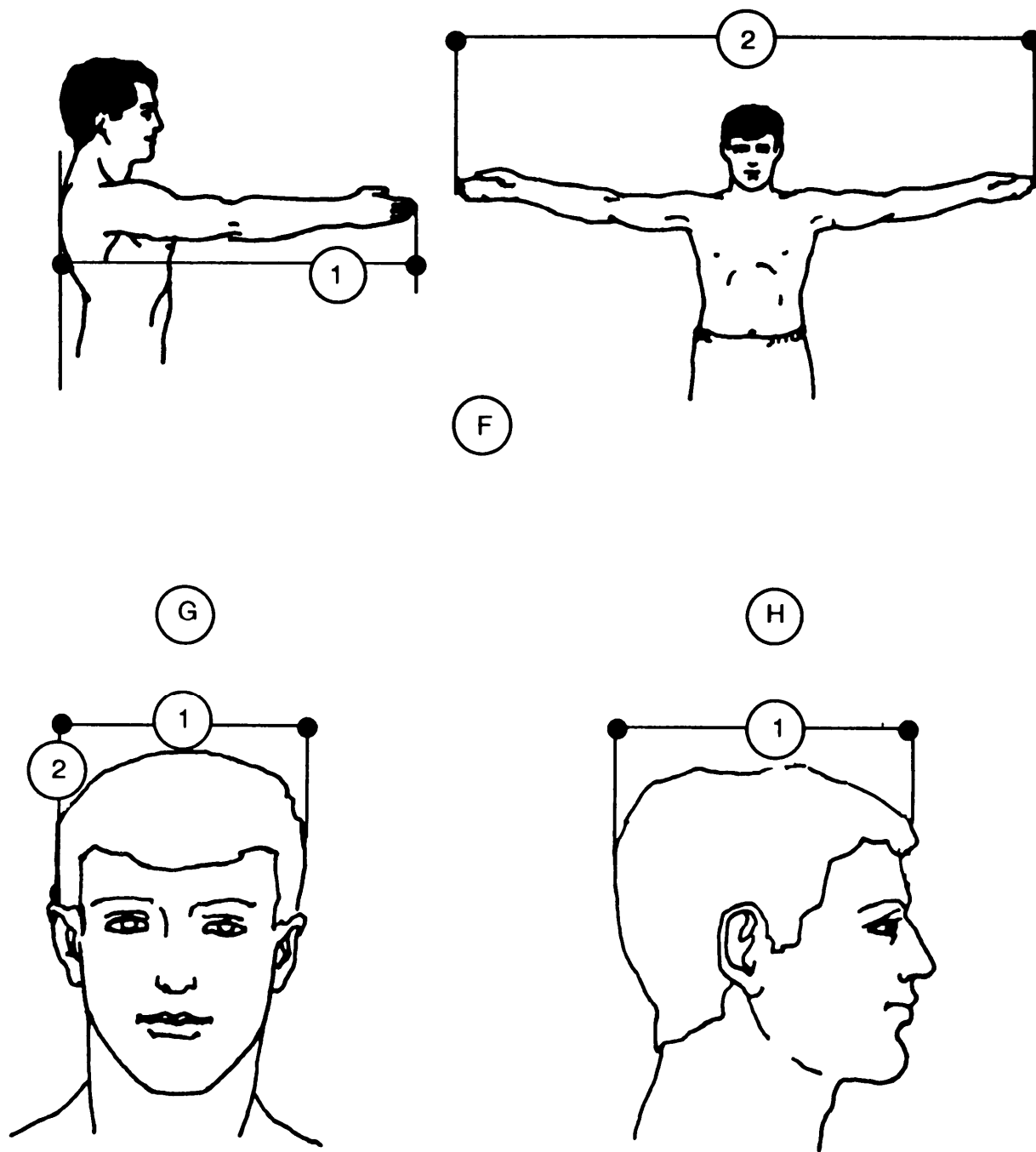

FIGURE 57. Body dimensions - continued

MIL-HDBK-759B

TABLE 48. Body dimensions measurements, including arctic clothing¹- continued

		Percentiles in Centimeters			
		5th Nude	Arctic Clothed ²	95th Nude	Arctic Clothed
F.	1. Functional Reach from Wall	72.6	77.7	90.9	95.5
	2. Span	165.1	177.7	191.0	194.6
G.	1. Head Breadth	14.4	23.0	16,3	23.0
	2. Head Length	11.9	16.5	14.5	20.0
H.	1. Head Length	18.3	27.7	20.7	27,7

¹Based on US Army Men, 1966²See 5.3.2.4.2 for Arctic Clothing Ensemble.

MIL-HDBK-759B

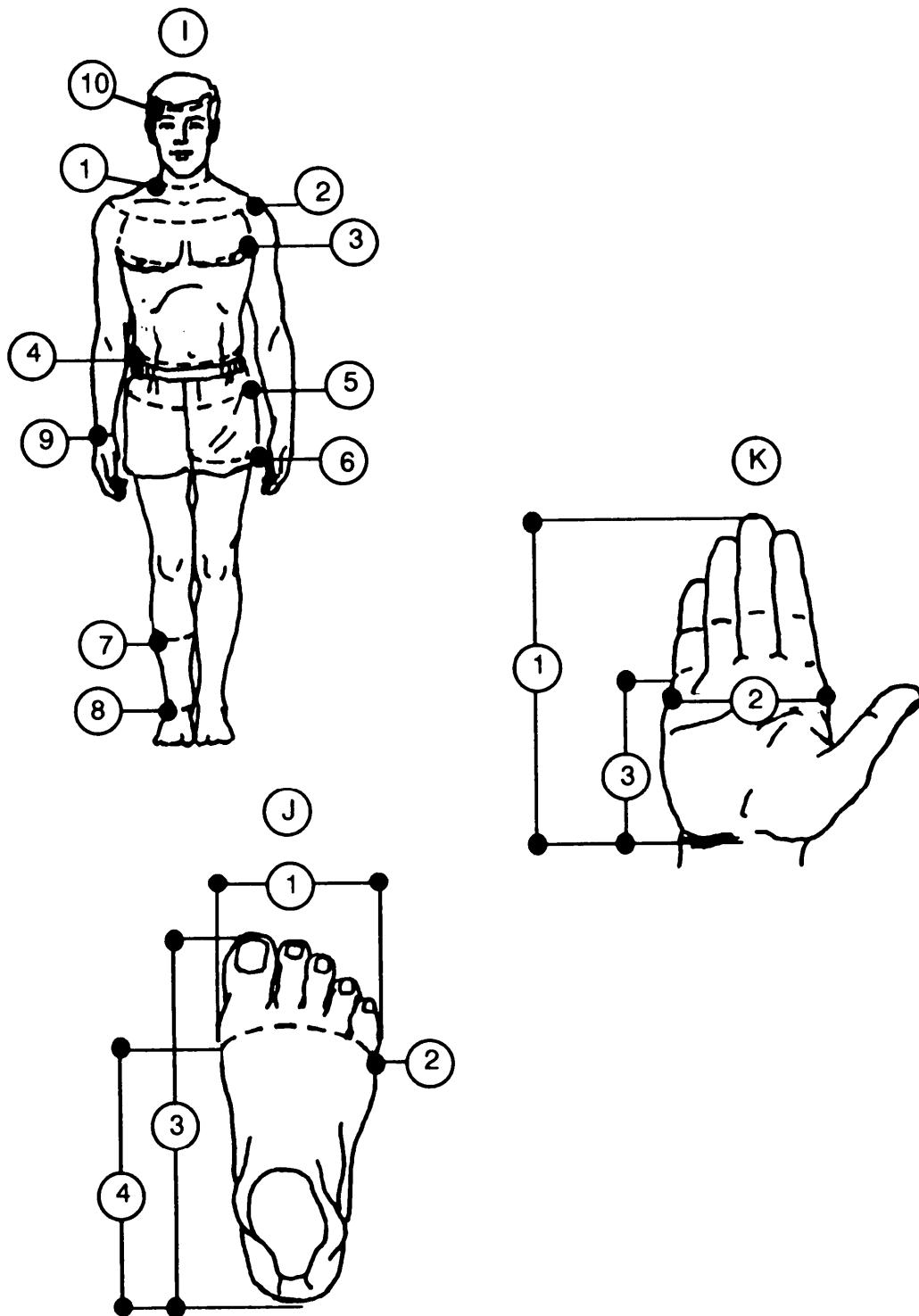

FIGURE 57. Body dimensions - continued

MIL-HDBK-759B

**TABLE 48. Body dimensions, including arctic clothing¹-
continued**

		Percentiles in Centimeters			
		5th Nude	Arctic Clothed ²	95th Nude	Arctic Clothed
1.	Body Circumferences				
	1. Neck	34.3	68.8	41.0	66.3
	2. Shoulder	103.5	131.0	124.2	151.5
	3. Chest	84.0	106.5	106.0	129.3
	4. Waist	70.0	97.3	96.0	127.0
	5. Hip	85.0	117.5	105.7	141.2
	6. Upper Thigh	48.0	61.2	63.8	77.0
	7. Calf	32.5	50.0	41.0	58.0
	8. Ankle	20.5	39.5	25.0	46.7
	9. Wrist	15.7	31.0	18.5	32.5
	10. Head	53.5	91.5	58.8	91.5
J.	Foot				
	1. Ball of Foot Breadth	9.0	12.2	10.8	13.5
	2. Ball of Foot Circumference	22.5	37.0	27.5	40.5
	3. Foot Length	24.7	32.3	29.0	34.9
	4. Ball of Foot Length	18.0	21.8	21.5	23.0
K.	Hand				
	1. Hand Length	17.5	20.8	20.7	24.0
	2. Hand Breadth at Metacarp	8.0	12.7	9.7	12.2
	3. Palm Length	9.5	10.5	11.7	12.4

¹Based on US Army Men, 1966²See 5.3.2.4.2 for Arctic Clothing Ensemble.

MIL-HDBK-759B

TABLE 49. Clothed body dimensions of the 5th and 95th percentile soldier

	Basic Uniform		Additions to the Basic Uniform					
	5th	95th	Blouse or Field Jacket	Blouse or Field Jacket Overcoat	5th	95th	Combat Suite Overcoat Gloves, Wool Cap and Combat Boots	
Weight (Kg)	62.3	101.8	63.4	102.9	66.5	106.0	68.9	108.4
Body Dimensions (cm)*								
A-1 Stature	170.0	192.3	169.9	192.3	169.9	192.3	107.0	192.5
D-1 Sitting Height	87.1	100.3	87.4	100.6	87.9	100.8	88.1	101.1
E-6 Eye Height, Sitting	71.9	84.3	72.1	84.6	72.4	84.8	72.6	85.1
D-2 Mid-Shoulder Height, Sitting	56.9	63.5	57.9	69.6	58.9	70.4	53.9	70.4
D-7 Knee Height, Sitting	52.8	62.2	52.8	62.2	53.1	62.2	53.1	62.2
D-5 Buttock-Knee Length	55.1	65.0	55.4	65.3	55.6	65.5	56.1	66.0
D-3 Shoulder-Elbow Length	34.3	40.6	35.3	41.7	36.3	42.7	36.3	42.7
E-1 Shoulder Breadth	42.7	51.6	44.5	53.3	46.0	54.9	46.0	54.9
A-5 Chest Breadth	28.5	35.6	28.7	35.8	29.2	36.3	29.7	36.8
E-2 Forearm-Forearm Breadth	41.4	52.2	42.7	58.2	44.7	60.2	45.5	61.0
C-2 Hip Breadth	31.8	38.9	37.3	39.4	39.2	40.1	34.0	40.9
E-3 Hip Breadth, Sitting	32.3	40.9	32.8	41.4	33.8	42.2	34.5	42.9
B-1 Chest Depth	21.8	22.9	23.1	30.5	25.4	32.5	25.4	32.5
J-3 Foot Length	27.7	32.8	27.7	32.8	27.7	32.8	32.3	34.5
J-1 Foot Breadth	10.2	11.9	10.2	11.9	10.2	11.9	12.2	13.7
K-1 Hand Length**								
K-2 Hand Breadth**								

*The letter and number associated with each body dimension refers to the drawings in Figure 57

**See Figure 62 for 95th percentile man

MIL-HDBK-759B

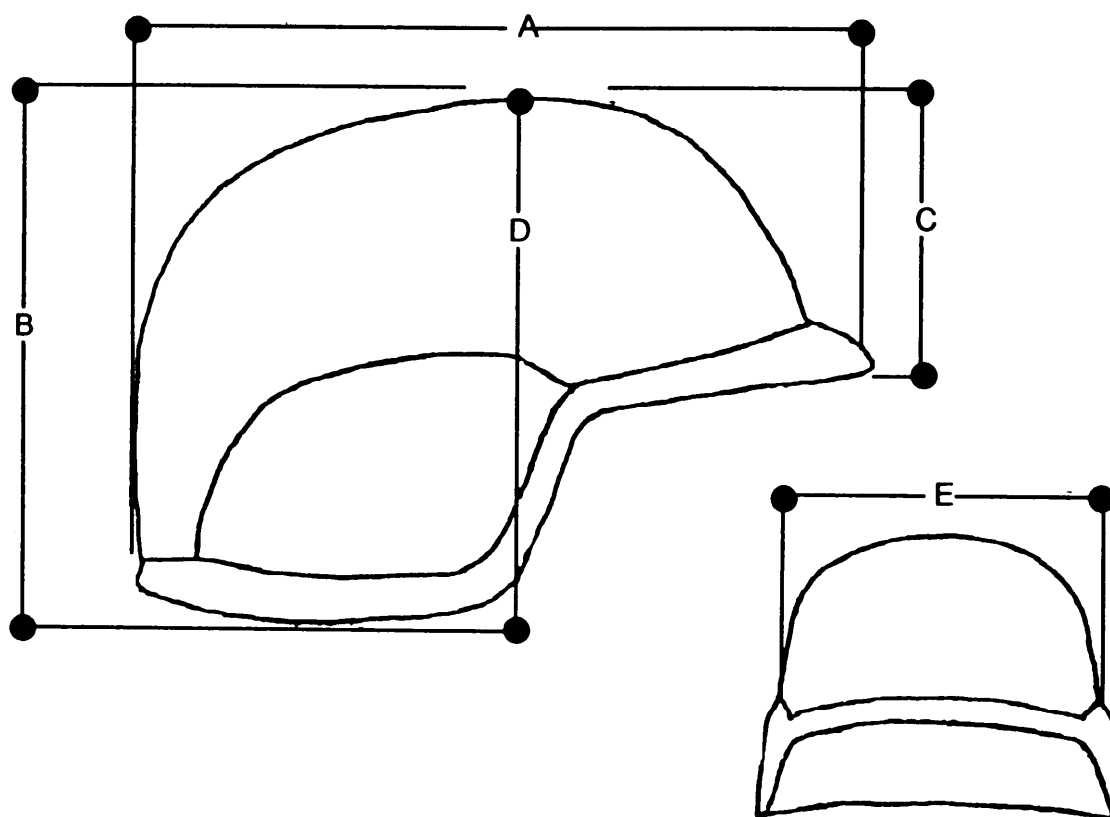

<u>Dimension</u>	<u>Size (mm)</u>
A. Length of helmet, front rim to rear rim	285
B. Height, from back to top	160
C. Height, from front to top	125
D. Height, from side to top	180
E. Breadth of helmet	255

FIGURE 58. PASGT helmet dimensions*

*Size Large

MIL-HDBK-759B

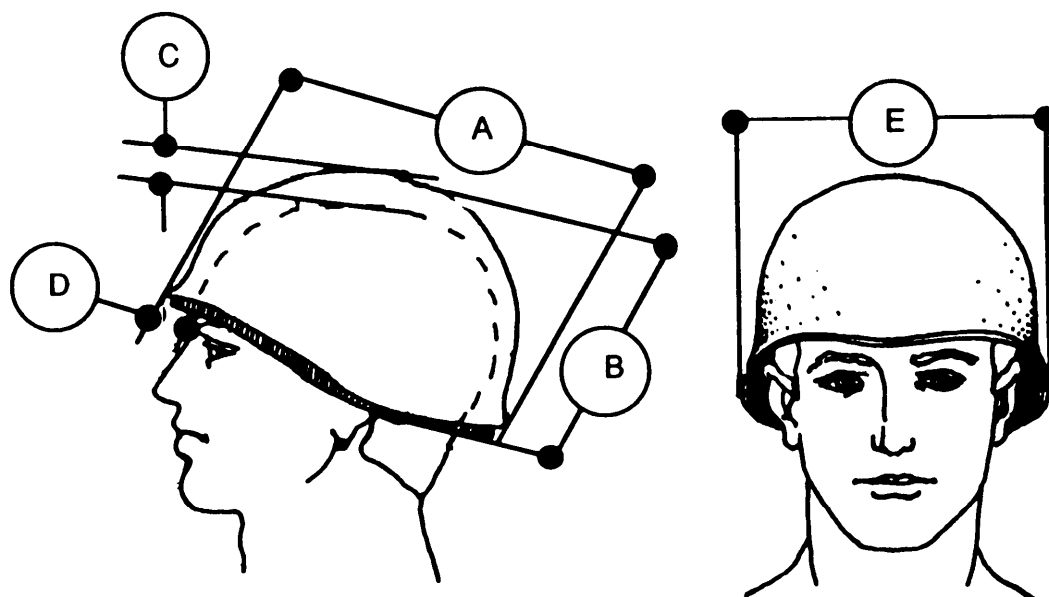

Dimension	Maximum Size (mm)
A. Length, front rim to rear rim	280
B. Height	170
C. Top of head to top of helmet	50
D. Eyebrow ridge to front rim	50
E. Width, rim to rim	235

FIGURE 59. M-1 Helmet dimensions

MIL-HDBK-759B

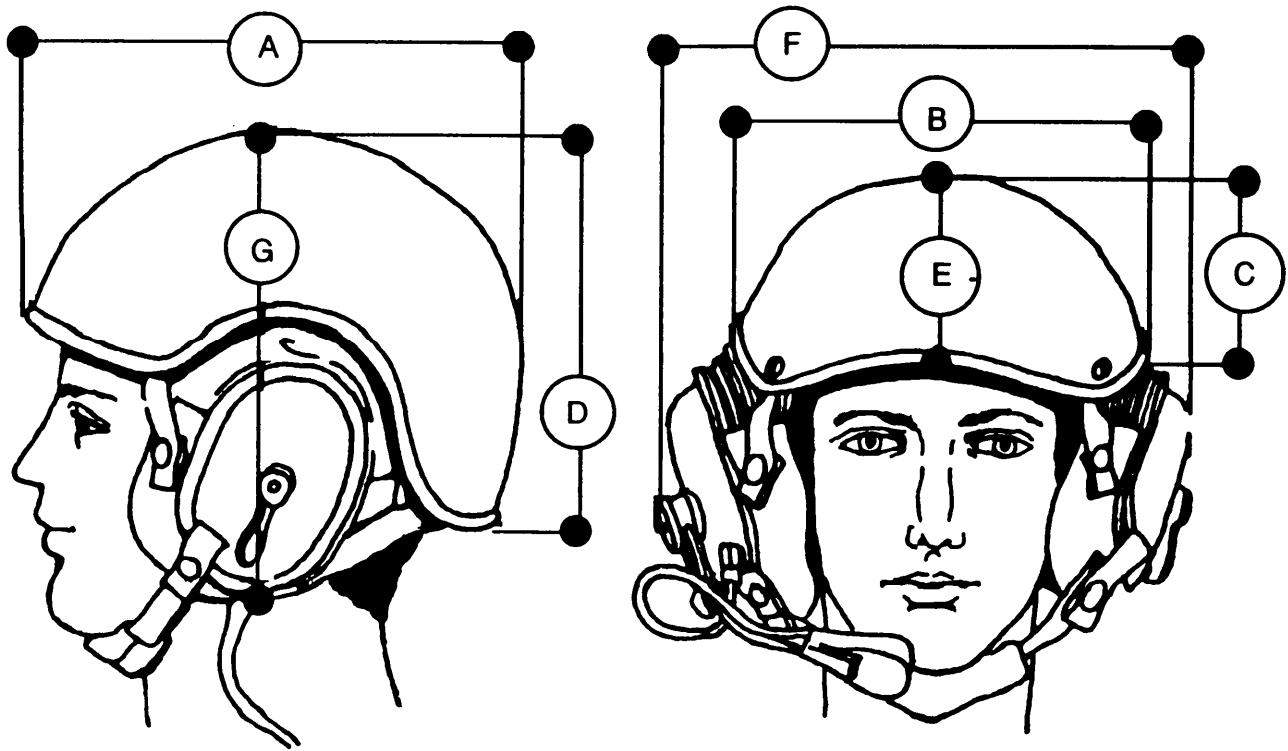

Dimension	Size (mm)
A. Length of helmet	265
B. Helmet breadth (shell)	210
C. Height of shell above ear to top	110
D. Height back of shell to top	200
E. Height front of shell to top	90
F. Helmet breadth	290
G. Height from bottom of ear to top	245 (Approximate)

FIGURE 60. CVC helmet - DH-132 dimensions*

*Size Large

MIL-HDBK-759B

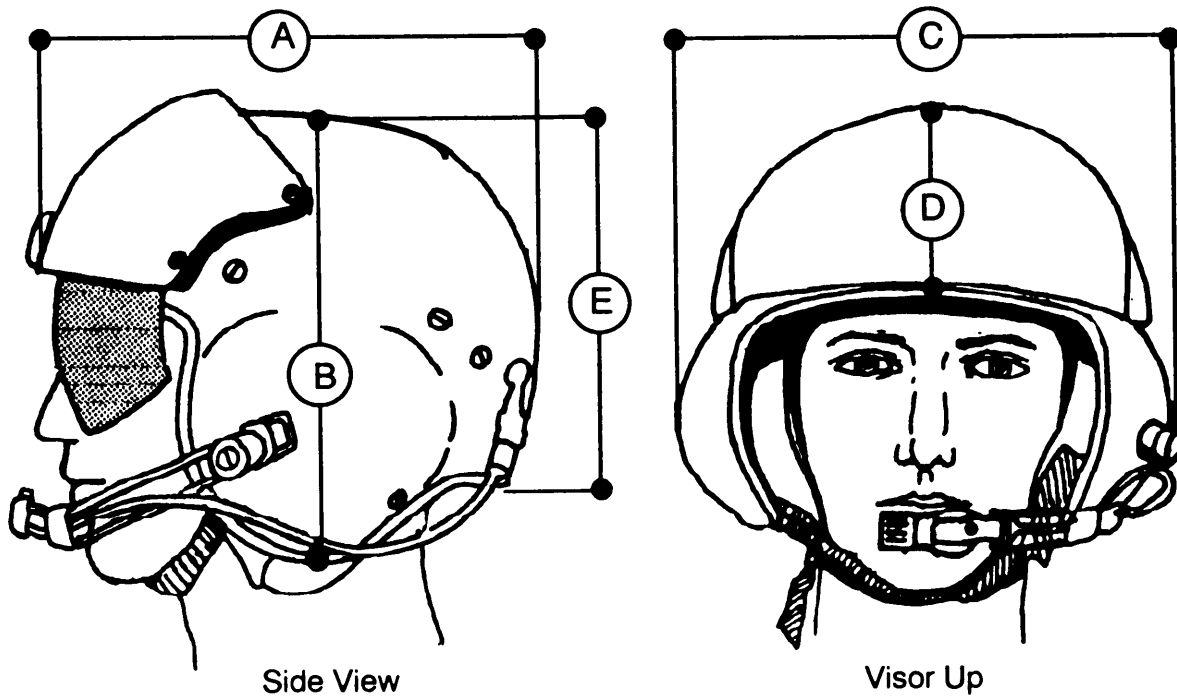

Side View

Visor Up

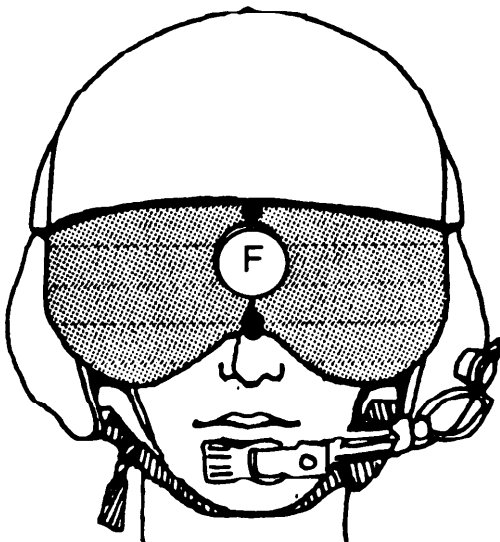

Visor Down

Dimension	Size (mm)
A. Length of helmet	280
B. Height of helmet shell	240
C. Helmet breadth	290
D. Height from front to top	140
E. Height from back to top	180
F. Sun shield at nose cut-away	65

FIGURE 61. Aircrewman's helmet, SPH4 dimensions*

Size Extra Large

MIL-HDBK-759B

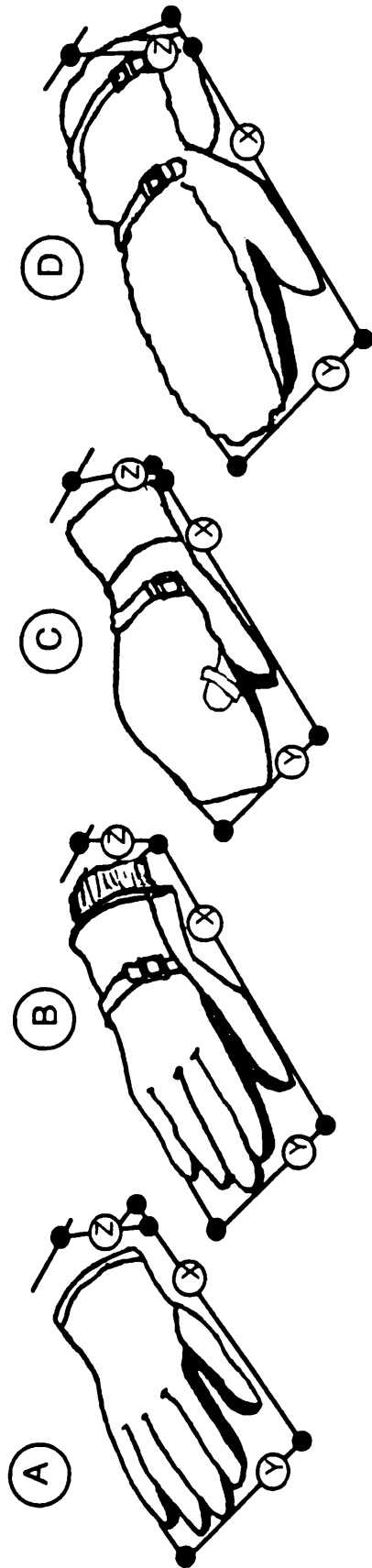

Hand Position	A Anticrystall Glove			B Wet-Cold Glove			C Wet-Cold Mitten			D Arctic Mitten		
	X	Y	Z	X	Y	Z	X	Y	Z	X	Y	Z
Extended Flat	26.7	11.9	6.4	27.2	14.5	7.6	36.1	15.2	8.1	42.2	13.7	9.1
Closed as Fist	17.8	12.7	8.4	18.5	14.7	9.4	29.2	14.7	9.7	36.3	13.2	13.7
Grasping Handle	17.8	12.7	8.9	18.5	14.0	8.9	27.4	14.5	10.7	35.6	14.0	11.4
0.6 cm diameter	17.8	12.7	8.9	18.5	13.5	10.2	27.4	13.2	11.4	35.6	13.2	11.4
2.5 cm diameter	19.0	11.4	10.7	20.3	11.9	10.2	30.5	13.2	11.9	38.1	13.7	12.7
5.0 cm diameter	20.3	9.7	10.9	22.9	11.7	10.2	29.2	12.7	10.7	39.4	12.2	11.4
Grasping Knob	22.9	8.9	10.2	22.9	11.4	10.2	30.5	12.7	10.7	40.1	12.2	12.2
0.6 cm diameter	24.1	9.4	9.4	23.4	11.4	10.7	31.8	11.9	11.2	40.6	11.9	12.2
2.5 cm diameter												
5.0 cm diameter												

FIGURE 62. Gloved-hand dimensions for 95th percentile male

MIL-HDBK-759B

This Page Intentionally Left Blank.

MIL-HDBK-759B

5.3.2.4.3 Slump factor. Seated eye-height measurements may be reduced as much as 65 mm when personnel sit in a relaxed or slumped position. This slump factor should be considered when selecting the range of movement for adjustable seats, as well as in locating displays, optics, and vision ports. The slump factor is not a valid reason for lowering ceilings to save space.

5.3.2.4.4 Human subjects. Once the equipment or workspace design has progressed from the drawing board to a full scale mockup, the use of persons closely resembling various percentiles in conjunction with the mockup is a valuable design practice.

5.3.2.4.5 Information sources. Data on arm and leg reach, center-of-mass and joint centers for body segments and the inertial properties of the human body are sometimes of interest to equipment and workspace designers. Data are available in various publications. An example of a convenient and informative source of data is the NASA Reference Publication 1024, "Anthropometric Source Book, Volume 1: Anthropometry for Designers".

5.3.3 Body movement.

5.3.3.1 Range of human motion. Table 50 gives the ranges, in angular degrees, for all voluntary movements the joints of the body can make, as illustrated in Figure 63. The designer should remember that these are maximum values; since they were measured with nude personnel, they do not reflect the restrictions clothing would impose. The following general instructions apply to the dimensions in Table 50.

- a. The lower limit should be used when personnel must operate or maintain a component.
- b. The upper limit should be used in designing for freedom of movement.

5.3.3.2 Whole body. All operating positions should allow enough space to move the trunk of the body. When large forces (more than 13.6 kg) or large control displacements (more than 380 mm in a fore-aft direction) are required, the operator should have enough space to move his entire body.

MIL-HDBK-759B

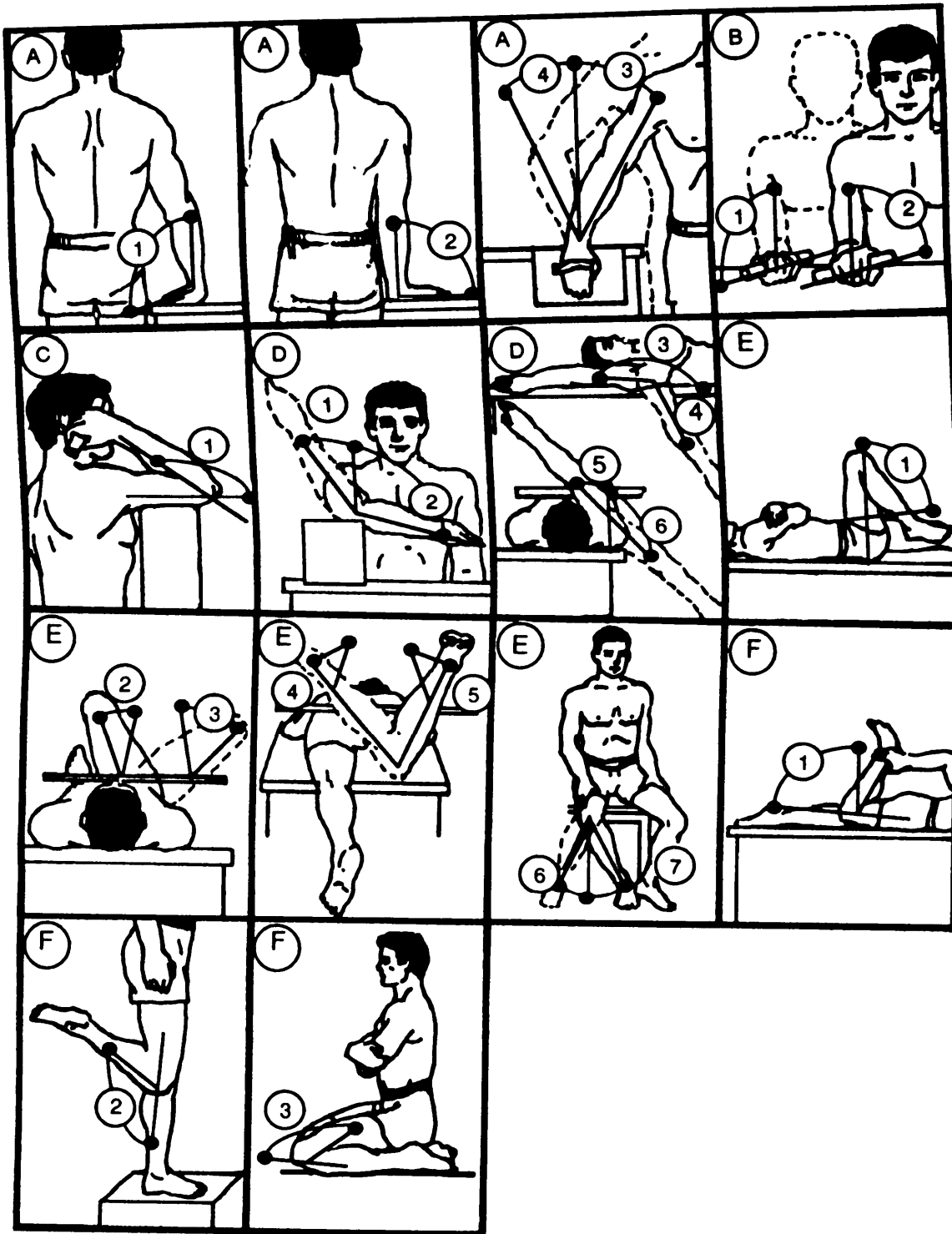

FIGURE 63. Range of human motion

MIL-HDBK-759B

TABLE 50. Range of human motion¹

Body Member	Movement	Lower Limit (degrees)	Average (degrees)	Upper Limit (degrees)
A. Wrist	1. Flexion	78	90	102
	2. Extension	86	99	112
	3. Adduction	18	36	27
	4. Abduction	40	54	47
B. Forearm	1. Supination	91	113	135
	2. Pronation	53	77	101
C. Elbow	1. Flexion	132	142	152
D. Shoulder	1. Lateral Rotation	21	34	47
	2. Medial Rotation	75	97	119
	3. Extension	47	61	75
	4. Flexion	176	188	190
	5. Adduction	39	48	57
	6. Abduction	117	134	151
E. Hip	1. Flexion	100	113	126
	2. Adduction	19	31	43
	3. Abduction	41	53	65
	4. Medial Rotation (prone)	29	39	49
	5. Lateral Rotation (prone)	24	34	44
	6. Lateral Rotation (sitting)	21	30	39
	7. Medial Rotation (sitting)	22	31	40
F. Knee Flexion	1. Prone	115	125	135
	2. Standing	100	113	126
	3. Kneeling	150	159	168

¹These values are based on the nude body. The ranges are larger than they would be for clothed personnel.

MIL-HDBK-759B

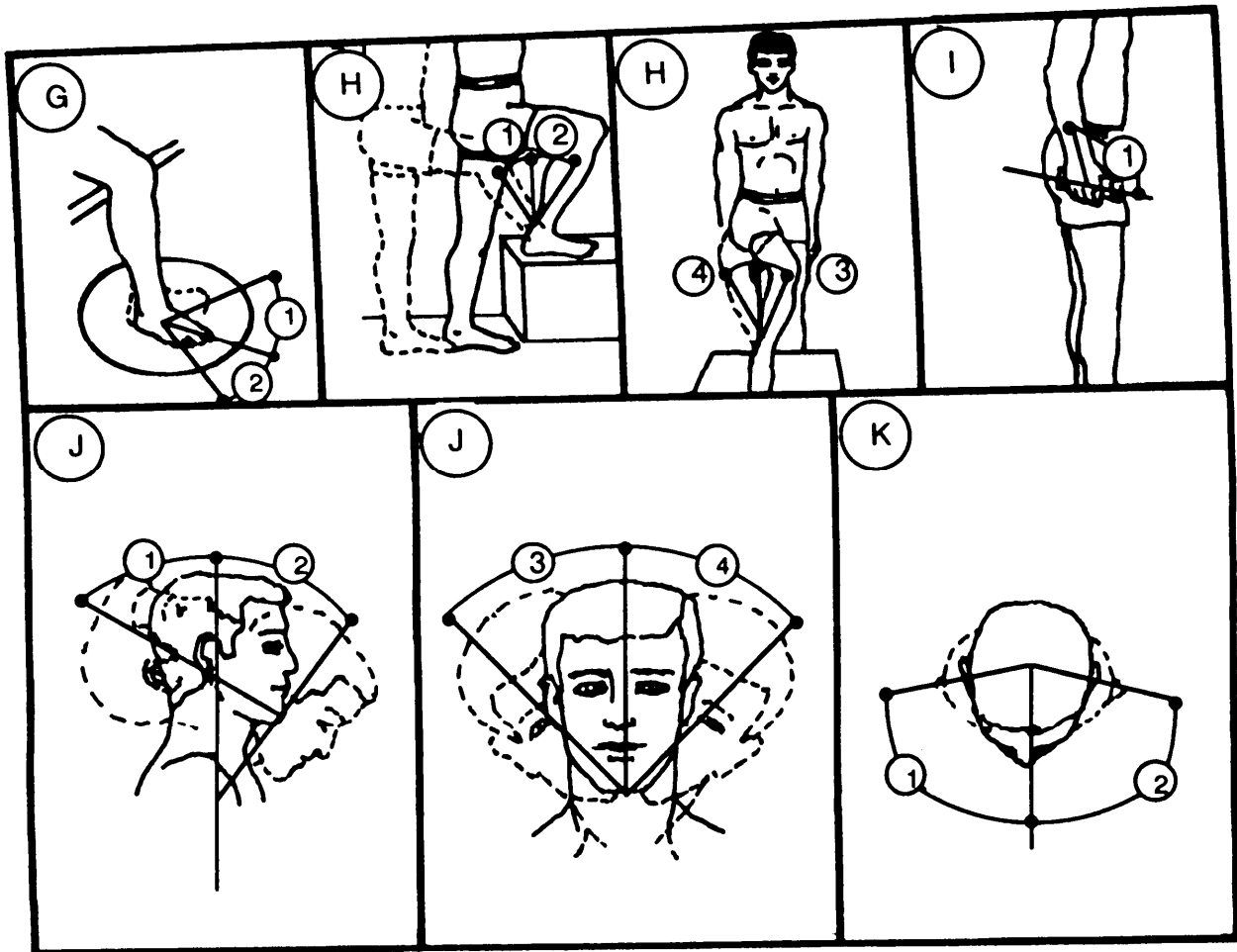

63. Range of human motion - continued

MIL-HDBK-759B

TABLE 50. Range of human motion¹- continued

Body Member	Movement	Lower Limit (degrees)	Average (degrees)	Upper Limit (degrees)
G. Foot Rotation	1. Medial	23	35	47
	2. Lateral	31	43	55
H. Ankle	1. Extension	26	38	50
	2. Flexion	28	35	42
	3. Adduction	15	33	24
	4. Abduction	16	30	23
I. Grip Angle		95	102	109
J. Neck Flexion	1. Dorsal (back)	44	61	88
	2. Ventral (forward)	48	60	72
	3. Right	34	41	48
	4. Left	34	41	48
K. Neck Rotation	1. Right	65	79	93
	2. Left	65	79	93

¹These values are based on the nude body. The ranges are larger than they would be for clothed personnel.

Flexion: Bending, or decreasing the angle between parts of the body.

Extension: Straightening, or increasing the angle between parts of the body.

Adduction: Moving toward the midline of the body.

Abduction: Moving away from the midline of the body.

Medial Rotation: Turning toward the midplane of the body.

Lateral Rotation: Turning away from the midplane of the body.

Pronation: Rotation of the palm of the hand downward.

Supination: Rotation of the palm of the hand upward.

MIL-HDBK-759B

5.3.4 Human strength and handline capacity

5.3.4.1 Exerted forces. The maximum amount of force or resistance designed into a control should be determined by the greatest amount of force that can be exerted by the weakest person likely to operate the control. The maximum force that can be applied will depend on such factors as the type of control, the body member used to operate it, the position of this body member during control operations, the general position of the body, and whether or not support is provided by backrests. Figures 64 and 65 list the forces that can be exerted by 95% of the male population, for various directions of movement and body members.

5.3.4.2 Push and pull forces.

5.3.4.2.1 Horizontal. Manual horizontal push and pull forces initially required to be applied to an object to set it in motion or to be sustained over a period of time, should not exceed the values of Table 51, as applicable. Use of the maxima shown in Table 51 is predicated upon a suitable surface for force exertion (vertical with rough surface approximately 400 mm wide between 0.51 and 1.27 m above the floor to allow force application with the hands, the shoulders, or the back).

5.3.4.2.2 Vertical. Manual vertical push and pull forces required should not exceed the applicable fifth percentile peak or mean force values of Table 52. The values shown in Table 52 and illustrated in Figure 66 are based on static strength measurements of 349 Army women and 102 Army men dressed in normal indoor apparel. The mean forces shown represent force over a three-second interval, beginning two seconds after the force reached a minimum value of 45 N providing that at this time the force still exceeded this minimum. Table 52 reflects the higher measurement of two trials for each condition.

5.3.4.3 Lifting.

5.3.4.3.1 Comparative strength. Much research, currently investigating the maximum lifting characteristics of males and females, has produced little insight into the relative strength of women to men. The US Army Research Institute of Environmental Medicine (ARIEM) has also been collecting data in this area. While much of their data is still undergoing analysis, ARIEM suggests the following strength relationship:

For upper extremities, women's strength is 56.5% of men.

For lower extremities, women's strength is 64.2% of men.

For trunk extremities, women's strength is 66.0% of men.

These numbers (based on sample size N = 1500) may serve as a preliminary design guideline until more up-to-date information may be available.

MIL-HDBK-759B

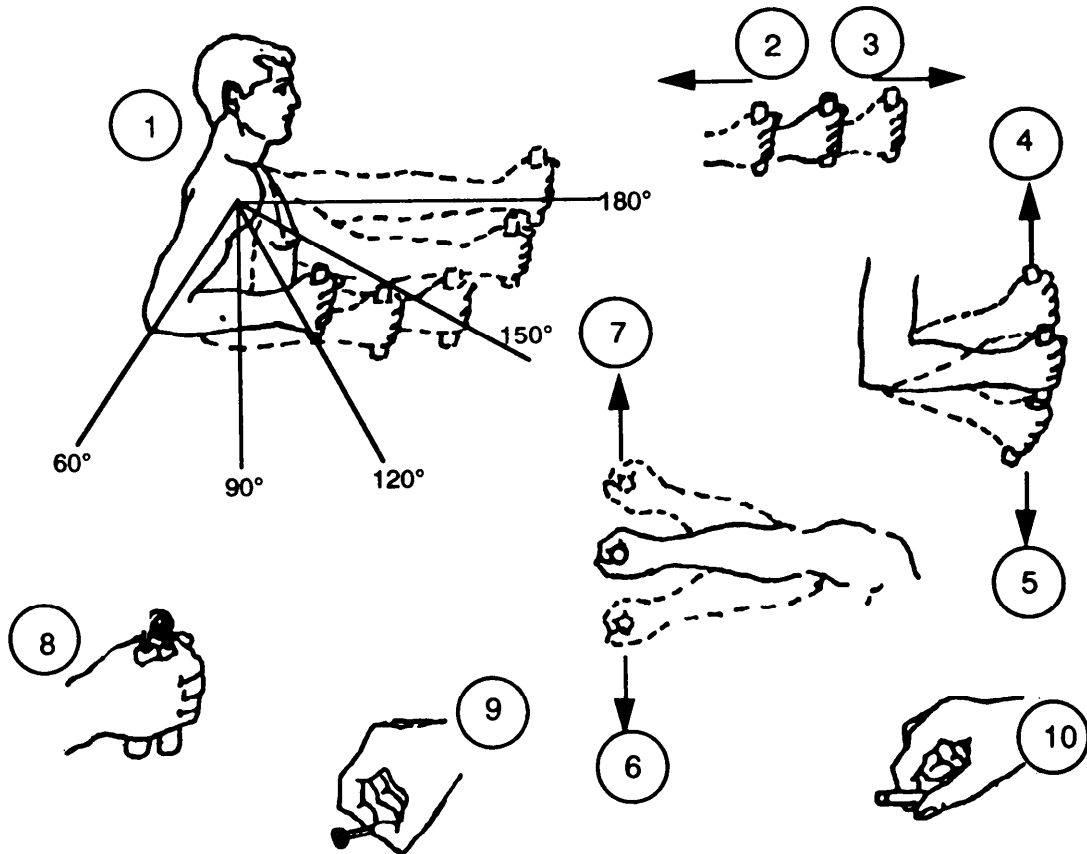

ARM STRENGTH (N) FOR SITTING MAN

1 ELBOW FLEXION	2 PULL		3 PUSH		4 UP		5 DOWN		6 IN		7 OUT	
	L	R*	L	R	L	R	L	R	L	R	L	R
180°	222	231	187	222	40	62	58	76	58	89	36	62
150°	187	249	133	187	67	80	80	89	67	89	36	67
120°	151	187	116	160	76	107	93	116	89	98	45	67
90°	142	165	98	160	76	89	93	116	71	80	45	71
60°	116	107	98	151	67	89	80	89	76	89	53	76

HAND AND THUMB-FINGER STRENGTH (N)

HOLDING TIME	8 HAND GRIP		9 THUMB-FINGER GRIP (PALMAR)	10 THUMB-FINGER GRIP (TIPS)
	LEFT	RIGHT		
MOMENTARY HOLD	250	260	60	60
SUSTAINED HOLD	145	155	35	35

* L = LEFT; R = RIGHT

FIGURE 64. Arm, hand, and thumb-finger strength (5th percentile male)

MIL-HDBK-759B

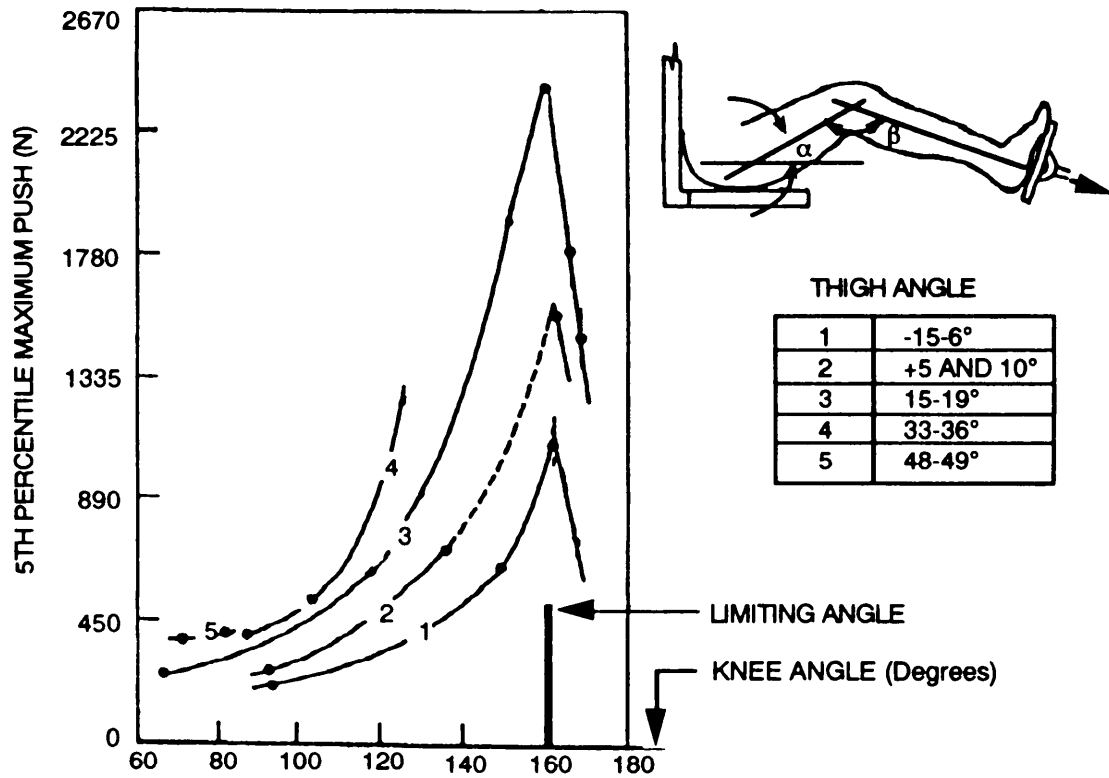

The push force exerted by the leg depends upon the thigh angle and the knee angle. The maximum push is at about the 160° knee angle referred to as the limiting angle.

FIGURE 65. Leg strength at various knee and thigh angles

MIL-HDBK-759B

TABLE 51. Horizontal push and pull forces exorable (intermittently or for short periods of time)

Horizontal Force ¹ at Least	Applied with	Condition (μ : Coefficient of Friction)
110 N push or pull	both hands or one shoulder or the back	with low traction $0.2 < \mu < 0.3$
200 N push or pull	both hands or one shoulder or the back	with medium traction $\mu \sim 0.6$
240 N push	one hand	if braced against a vertical wall 510-1520 mm from and parallel to the push panel
310 N push or pull	both hands or one shoulder or the back	with high traction $\mu > 0.9$
490 N push or pull	both hands or one shoulder or the back	if braced against a vertical wall 510-1780 mm from and parallel to the panel or if anchoring the feet on a perfectly non-slip ground (like a footrest)
730 N push	the back	if braced against a vertical wall 580-1090 mm from and parallel to the push panel or if anchoring the feet on a perfectly non-slip ground (like a footrest)

¹ May be doubled for two and tripled for three operators pushing simultaneously. For the fourth and each additional operator, not more than 75% of the push capability should be added.

MIL-HDBK-759B

TABLE 52. Static muscle strength data

STRENGTH MEASUREMENTS	PERCENTILE VALUES IN N			
	5th PERCENTILE		95th PERCENTILE	
	MALE	FEMALE	MALE	FEMALE
A. STANDING TWO-HANDED PULL: 38 cm LEVEL MEAN FORCE PEAK FORCE	737.5 844.7	330.9 396.9	1354.5 1437.2	817.6 888.3
B. STANDING TWO-HANDED PULL: 50 cm LEVEL MEAN FORCE PEAK FORCE	758.0 830.9	326.1 374.1	1341.6 1441.7	840.7 905.2
C. STANDING TWO-HANDED PULL: 100 cm LEVEL MEAN FORCE PEAK FORCE	444.4 504.0	185.0 218.0	931.0 988.4	443.0 493.3
D. STANDING TWO-HANDED PUSH: 150 cm LEVEL MEAN FORCE PEAK FORCE	408.8 472.8	153.5 187.7	1016.9 1094.3	379.9 430.1
E. STANDING ONE-HANDED PULL 100 cm LEVEL MEAN FORCE PEAK FORCE	214.8 258.9	102.8 131.7	627.6 724.2	283.8 322.5
F. SEATED ONE-HANDED PULL: CENTERLINE, 45 cm LEVEL MEAN FORCE PEAK FORCE	222.3 273.1	106.3 127.2	678.4 758.4	391.9 450.6
G. SEATED ONE-HANDED PULL: SIDE, 45 cm LEVEL MEAN FORCE PEAK FORCE	239.8 272.7	109.0 134.3	603.6 658.8	337.2 394.6
H. SEATED TWO-HANDED PULL: CENTERLINE, 38 cm LEVEL MEAN FORCE PEAK FORCE	594.7 698.8	241.5 284.7	1221.0 1324.2	770.4 841.6
I. SEATED TWO-HANDED PULL: CENTERLINE, 50 cm LEVEL MEAN FORCE PEAK FORCE	524.9 595.6	204.2 237.1	1052.0 1189.0	631.6 697.0

MIL-HDBK-759B



- A. STANDING TWO-HANDED PULL: 38 cm LEVEL
STANDING WITH FEET 45 cm APART AND KNEES BENT. BENDING AT WAIST, GRASPING BOTH SIDES OF 45 cm LONG HANDLE LOCATED DIRECTLY IN FRONT, 38 cm ABOVE STANDING SURFACE, AND PULLING, USING PRIMARILY ARMS, SHOULDERS AND LEGS.



- B. STANDING TWO-HANDED PULL: 50 cm LEVEL
STANDING WITH FEET 45 cm APART AND KNEES STRAIGHT. BENDING AT WAIST, GRASPING BOTH SIDES OF 45 cm LONG HANDLE LOCATED DIRECTLY IN FRONT, 50 cm ABOVE STANDING SURFACE, AND PULLING, USING PRIMARILY ARMS AND SHOULDERS.



- C. STANDING TWO-HANDED PULL: 100 cm LEVEL
STANDING ERECT WITH FEET 45 cm APART, GRASPING BOTH SIDES OF 45 cm LONG HANDLE LOCATED DIRECTLY IN FRONT, 100 cm ABOVE STANDING SURFACE, AND PULLING, USING THE ARMS.

FIGURE 66. Static muscle strength data

MIL-HDBK-759B



D. STANDARD TWO-HANDED PUSH: 150 cm LEVEL
STANDING ERECT WITH FEET 45 cm APART, GRASPING FROM BELOW, BOTH SIDES OF 45 cm LONG HANDLE LOCATED DIRECTLY IN FRONT, 150 cm ABOVE STANDING SURFACE. PUSHING UPWARD USING ARMS AND SHOULDERS.

E. STANDING ONE-HANDED PULL: 100 cm LEVEL
DOMINANT HAND GRASPING UNDERSIDE OF D-RING LOCATED DIRECTLY TO THE SIDE, 100 cm ABOVE STANDING SURFACE. PULLING UPWARD WHILE KEEPING SHOULDER SQUARE AND OTHER ARM RELAXED AT SIDE.



F. SEATED ONE-HANDED PULL: SEAT CENTERLINE 45 cm LEVEL
SITTING ERECT WITH FEET 55 cm APART, DOMINANT HAND GRASPING UNDERSIDE OF D-RING LOCATED DIRECTLY TO THE FRONT, 45 cm ABOVE THE FLOOR. PULLING UPWARD WHILE KEEPING SHOULDER SQUARE AND OTHER ARM RESTING IN LAP.

FIGURE 66. Static muscle strength data - continued

MIL-HDBK-759B



G. SEATED ONE-HANDED PULL: SIDE OF SEAT, 45 cm LEVEL
SITTING ERECT WITH FEET 55 cm APART, DOMINANT HAND GRASPING UNDERSIDE OF D-RING LOCATED A SHORT DISTANCE TO SIDE, 45 cm ABOVE THE FLOOR. PULLING UPWARD WHILE KEEPING SHOULDERS SQUARE AND OTHER ARM RESTING IN LAP.



H. SEATED TWO-HANDED PULL: CENTERLINE OF SEAT, 38 cm LEVEL
SITTING ERECT WITH FEET 55 cm APART, BENDING SLIGHTLY AT WAIST, GRASPING BOTH SIDES OF 15 cm LONG HANDLE LOCATED DIRECTLY TO THE FRONT, 38 cm ABOVE THE FLOOR, PULLING UPWARD USING ARMS AND SHOULDERS, KEEPING ARMS OFF THIGHS,



I. SEATED TWO-HANDED PULL: CENTERLINE OF SEAT, 50 cm LEVEL
SITTING ERECT WITH FEET 55 cm APART, BENDING SLIGHTLY AT WAIST, GRASPING BOTH SIDES OF 15 cm LONG HANDLE LOCATED DIRECTLY TO THE FRONT, 50 cm ABOVE THE FLOOR. PULLING UPWARD USING ARMS AND SHOULDERS, KEEPING ARMS OFF THIGHS.

FIGURE 66. Static muscle strength data - continued

MIL-HDBK-759B

5.3.4.3.2 One Person Lift. Whenever possible, equipment should be designed so one person can lift it. Some lifting tasks may require two persons, but this is not normally desirable.

5.3.4.4 Lifting Limits. The weight limits in Table 53, conditions A and B, should be used as maximum values in determining the design weight of items requiring one person lifting with two hands. Double the weight limits in Table 53 should be used as the maximum values in determining the design weight of items requiring two person lifting, provided the load is uniformly distributed between the two lifters. If the weight of the load is not uniformly distributed, the weight limit applies to the heavier lift point. Where three or more persons are lifting simultaneously, not more than 75% of the one-person value may be added for each additional lifter, provided that the object lifted is sufficiently large that the lifters do not interfere with one another while lifting. Where it is not possible to define the height to which an object will be lifted in operational use, the limit wherein the object is lifted to shoulder height should be used rather than the bench height value. The values in Table 53 are applicable to objects with or without handles.

TABLE 53. Design weight limits

<u>HANDLING FUNCTION</u>	<u>Male and Female Population (kgs)</u>	<u>Male Only Population (kgs)</u>
A. Lift an object from the floor and place it on a surface not greater than 1.525 m above the floor	16.8	25.4
B. Lift an object from the floor and place it on a surface not greater than 915 mm above the floor	20.0	39.5
C. Carry an object 10 m or less	19.0	37.2

5.3.4.5 Lifting frequency. The equipment weight limits in Table 53 are not for repetitive lifting as found, for example, in loading or unloading transport vehicles. If the frequency of lift exceeds one lift in 5 minutes or 20 lifts per 8 hours, the permissible weight limits should be reduced by $(8.33 \times LF)$ percent, where LF is the lift frequency in lifts per minute. For example, if the lift frequency is 6 lifts per minute, then the maximum permissible weight is reduced by 50% ($8.33 \times 6 = 50$).

5.3.4.6 Load size. The maximum permissible weight lift limits in Table 53 are applicable to an object with uniform mass distribution and a compact size not exceeding 460 mm high, 460 mm wide, and 300 mm deep (away from the lifter.) This places the hand holds at half the depth, or 150 mm away from the body. If the depth of the object exceeds 610 mm the permissible weight should be reduced by 33%. If the depth of the object exceeds 910 mm the permissible weight should be reduced by

MIL-HDBK-759B

50%. If the depth of the object exceeds 1.220 m, the permissible weight should be reduced by 66%.

5.3.4.7 Obstacles. The values in Table 53 assume that there are no obstacles between the person lifting and the shelf, table, bench or other surface on which the object is to be placed. Where there is a lower protruding shelf or other obstacle limiting the lifter's approach to the desired surface, the weight of the limit of the object should be reduced by 33% for an obstacle exceeding 300 mm in depth, 50% for an obstacle exceeding 460 mm in depth, and 66% for an obstacle of 610 mm in depth. If the allowable weight should be reduced by both oversize load considerations (see 5.3.4.6) and the obstacle considerations, only the more restrictive single value should apply; two reductions should not be applied.

5.3.4.8 Carrying limits. The weight limit in Table 53, rendition C, should be used as the maximum value in determining the design weight of items requiring one-person carrying of objects a distance of up to 10 m. The maximum permissible weight for carrying also applies to an object with a handle on top, such as a tool box, which usually is carried at the side with one hand. Double this weight carrying limit should be used as the maximum value in determining the design weight of items requiring two-person carrying, provided the load is uniformly distributed between the two carriers. Where three or more persons are carrying a load together, not more than 75% of the one-person value may be added for each additional person and provided that the object is sufficiently large that the workers do not interfere with one another while carrying the load. In all cases involving carrying, it is assumed that the object is first lifted from the floor, carried a distance of 10 m or less, and placed on the floor or on another surface not higher than 915 mm. If the final lift is to a greater height, the 1.525 m lift height applies as the more limiting case.

5.3.4.9 Carrying frequency. The reduction formula expressed in 5.3.4.5 should be applied to repetitive carrying in the same manner as for repetitive lifting.

5.3.4.10 Object carry size. The reduction formula expressed in 5.3.4.6 should be applied to size of objects to be carried in the same manner as for load size.

5.3.4.11 User population. Unless otherwise specified by the acquiring activity, the values in Table 53 for Male and Female Population should apply to any object to be lifted or carried manually. Where the acquiring activity specifies that the object is to be lifted or carried only in a combat environment, the Male Only Population should be applied.

5.3.4.12 Other application limits. The limits in Table 53 should be further reduced to reflect additional conditions when the object is very difficult to handle (slippery), workspace is less than optimum, or the object should be positioned or handled delicately.

5.3.4.13 Labeling. Items weighing more than the one-person lift or carry values for Male and Female Population in Table 53 should be prominently labeled with weight of the object and lift limitation (mechanical or two-person lift, three-person lift).

MIL-HDBK-759B

Where mechanical or power lift is required, hoist and lift points should be provided and clearly labeled.

5.3.5 Workstation entrance and exit.

5.3.5.1 Routine. Enclosed work areas should have conventional entrances and exits for routine access to permit unrestricted flow for all anticipated traffic. They should be located so personnel who are entering or leaving will not operate controls accidentally or block access to controls.

5.3.5.2 Non-routine. Designers should consider providing auxiliary entrances as well as any needed emergency exits. Emergency exits should allow enough space for rapid exit of all occupants, including any who must carry essential equipment or wear bulky protective clothing, without danger of injuring personnel or damaging the equipment they carry.

5.3.6 Stairs, ladders and ramps.

5.3.6.1 General. Stairs, ladders and ramps should be:

- a. provided wherever operators or maintenance personnel must change elevation abruptly by more than 305 mm,
- b. selected to give the fastest, most efficient access to (and between) workplaces and areas,
- c. constructed of materials which are lightweight, non-conductive, splinterproof, waterproof, humidity resistant, and resistant to chemical action,
- d. strengthened to withstand the combined weight of the heaviest combination of personnel and equipment that is apt to be on them at any one time,
- e. provided with non-skid material on surfaces where personnel may step, walk, or stand,
- f. unencumbered by obstructions, edges, notches, or burrs that might injure personnel or damage hoses and cables,
- g. adequately lighted (see Tables 58 and 59),
- h. adequately marked to warn users against any dangers involved in using them (unavoidable low overhead and possible shock hazard),
- i. designed to be carried, handled, and positioned by one person wherever possible (but never more than two persons),
- j. used for safe, easy passage over low objects (pipes, lines, and ridges).

MIL-HDBK-759B

The layout and design of stairs, ladders, and ramps should make use of the considerations listed below.

- a. Limited amounts of space and clearance available.
- b. Expected environmental conditions, and especially whether the structure may get wet or be covered with ice or snow.
- c. The type, direction, and frequency of traffic over the structure.
- d. The relative efficiency of alternate traffic plans and patterns.
- e. Loads or other equipment users must carry.
- f. The configuration and weight of other equipment that may have to move over the structure.

5.3.6.2 Angle of inclination. The primary basis for choosing among stairs, ladders, and ramps is the structure's angle of inclination, which in turn depends on available space and structural constraints. Figure 67 shows the optimum and acceptable angles of incline for these structures.

5.3.6.3 Ladders.

5.3.6.3.1 Stair ladders. Stair ladders are preferable to rung ladders since they provide better footing and faster, safer passage. However, it is dangerous for personnel to carry loads up or down stair ladders; for sure balance and fast movement, personnel should have both hands free to use the handrails. When stair ladders are used, clearance should be chosen to accommodate a single person. If there will be simultaneous two-way traffic, provide separate UP and DOWN ladders, located side by side, with double handrails in the center spaced at least 150 mm apart (200 mm spacing recommended). For stair ladder dimensions, see Figure 68.

5.3.6.3.2 Rung ladders. Rung ladders are acceptable for occasional traffic, but they should not be used for frequent passage. They are comparatively unsafe, difficult to climb, and difficult from which to accomplish work. Loads cannot be carried up rung ladders safely unless they are strapped to personnel. As contrasted to semi-permanent or movable ladders (see Figure 70), fixed ladders (see Figure 71) are preferable because they are more stable, pose fewer clearance problems, and can be protected with guardrails, safetybelt rigging, and other safety features. Portable ladders should be avoided; when used at all, they should be restricted to emergency functions, infrequent maintenance tasks, or tactical situations where fixed ladders are impractical. For rung ladder dimensions see Figure 69.

5.3.6.3.3 Fixed ladders. When several floors are connected with ladders, they should be offset so users can never fall more than one floor. For personnel safety, there should be a guarded landing at each floor and guardrails at the entrances to open well ladders. When fixed ladders are over 6.1 m long, they should have ladder

MIL-HDBK-759B

cages (see Figure 69) that are free of projecting edges and obstructions on the inside edges.

5.3.6.3.4 Handrail. To provide good handrails, ladders should have round rungs. However, level steps, 75-100 mm deep are also acceptable if there are handrails on both sides of the ladders.

5.3.6.3.5 Moving parts. Two-section extension ladders should assemble with permanently captive hardware such as hinges and locks rather than bolts and nuts. Folding ladders should have catches and locking mechanisms that are simple, easy to release, and easy to maintain by the suitably-clothed and -equipped users with applicable 5th to 95th percentile body dimensions.

5.3.6.3.6 Safety devices. Both fixed and portable ladders should have safety devices appropriate for their length, use, and operating conditions. For example, long ladders used in adverse weather or under emergency conditions should have carrier rails and safety belts; ladders erected against poles should have pole-lashing devices. In addition, moveable ladders should have secure feet which are not apt to slip. Secure ladder feet include rubber-cleated, pivoted feet for temperatures above freezing and steel cleats for use in ice and snow.

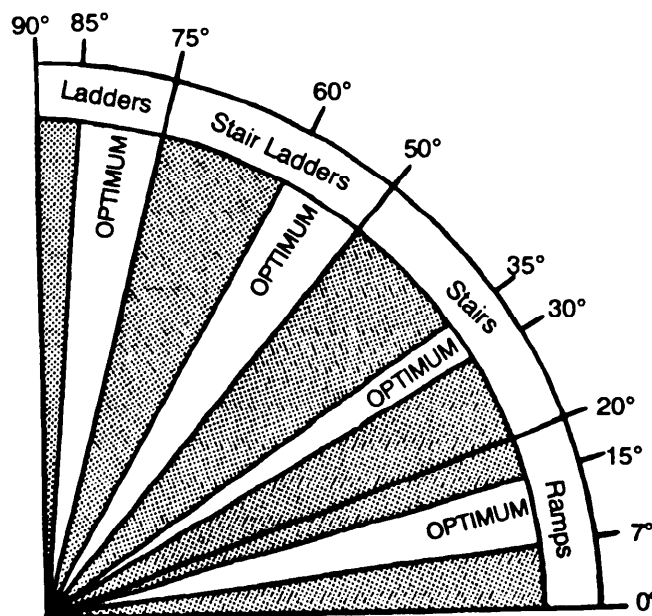

FIGURE 67. Incline angles for the use of various structures

MIL-HDBK-759B

A. Angle of rise:	50°	75°
B. Tread depth:		
for 500 rise:	150	255
for 750 rise:	75	145
C. Riser height:	180	300
D. Height, step to landing:	150	300
E. Width, handrail-handrail:	535	610
F. Min. overhead clearance:	1.7m	
G. Height of handrail:	860	940
H. Diameter of handrail:	30	50
I. Min. hand clearance:	75	

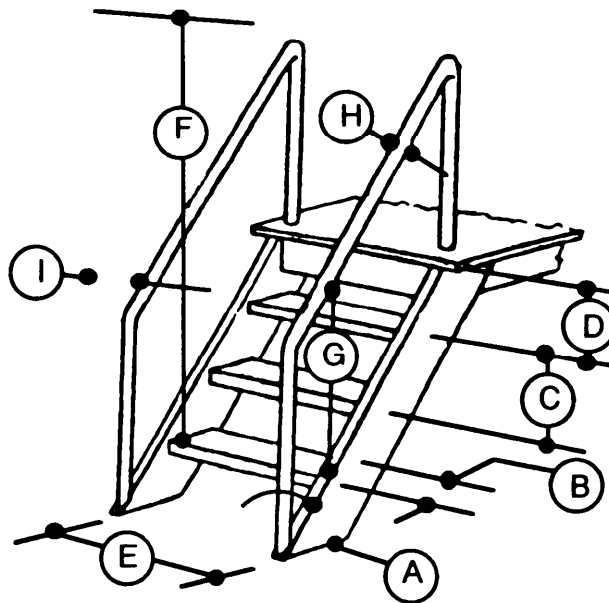

FIGURE 68. Stair-ladder dimensions (in mm except where marked)

A. Height of cage from base of ladder:	2.1 m
B. Flare at bottom of cage:	810
C. Depth of cage from center of ladder:	710
D. Max. distance between cage ribs:	460
E. Width of cage:	680
F. Rung diameter:	See fixed ladders
G. Rung spacing:	See fixed ladders
H. Maximum ladder length:	
Single section ladders:	9.1m
Two-section metal ladders:	14.6m
Two-section wood ladders:	18.3m
I. Min. width between siderails:	
Metal ladders:	300
Wood ladders up to 3m long:	290

Add 6mm for each additional
610mm in length

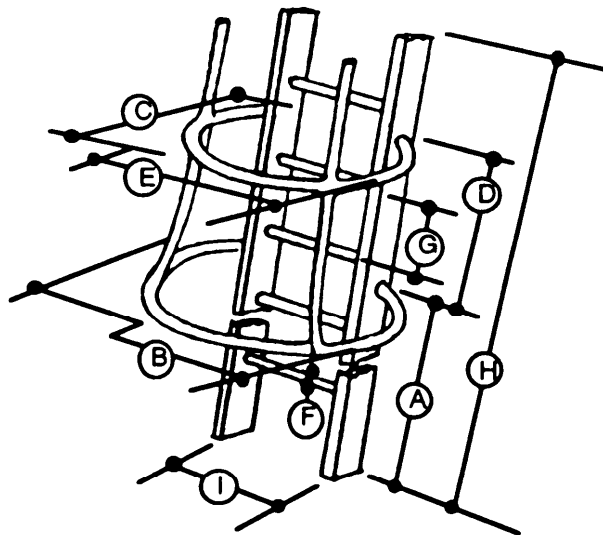
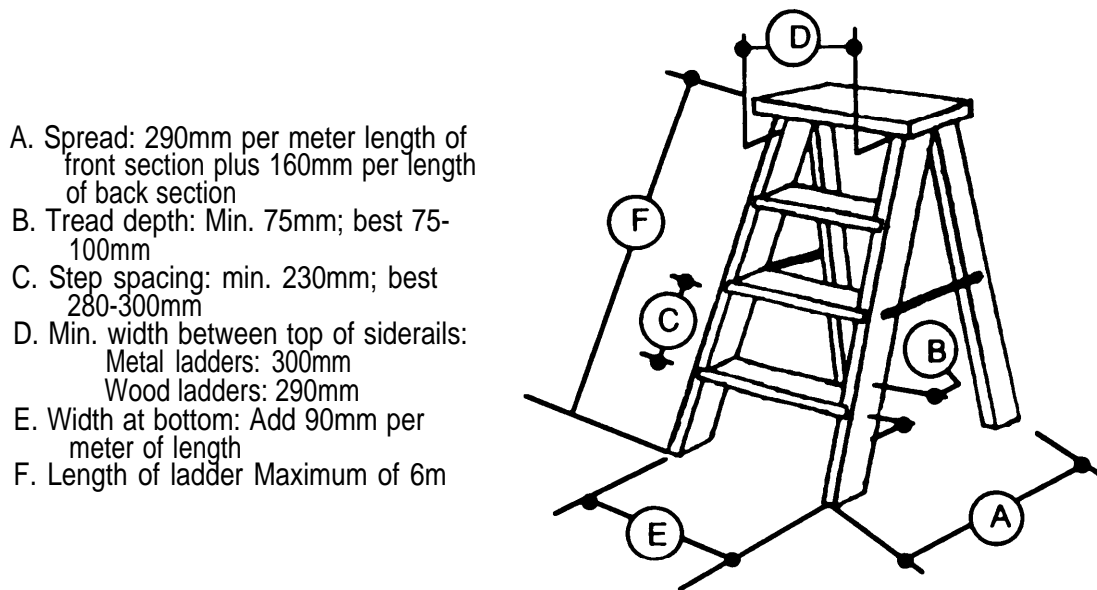
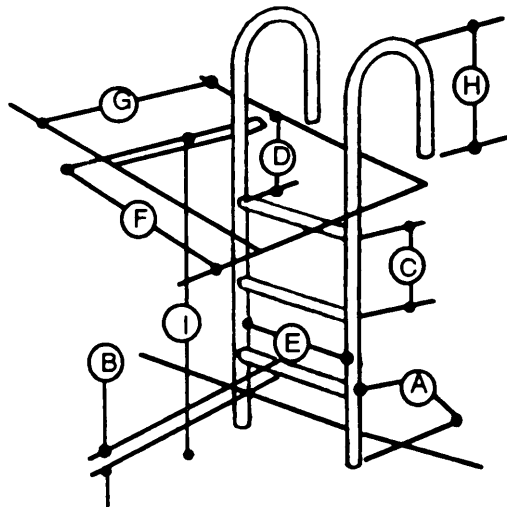

FIGURE 69. Rung-ladder and ladder-cage dimensions

MIL-HDBK-759B

**FIGURE 70. Step-ladder dimensions**

	Min.	Max.
A. Angle of rise:	75°	90°
B. Rung or cleat diameter		
Wood:	30	40
Protected metal:	20	40
Metal that may rust:	25	40
C. Rung spacing:	230	380
D. Height, rung to landing:	150	380
E. Width between stringers:	300	—
F. Climbing clearance width:	610	—
G. Min. clearance depth:		
In back of ladder:	150	—
On climbing side:	910 for 75° 750 for 90°	—
H. Height of string above landing	840	—
I. Max heightt of climb:	—	3m

**FIGURE 71. Fixed-ladder dimensions (in mm except where marked)**

MIL-HDBK-759B

5.3.6.3.7 Weights. Where one person must lift ladders and store them by hand, ladder weights should be limited as shown below, depending on how high above ground level the ladder must be lifted:

<u>Lift Distance (Meters)</u>	<u>Weight (Kilograms)</u>
1.52	11.3
1.83	9.0

5.3.6.4 Stairs.

5.3.6.4.1 General. Long flights of stairs should be avoided. There should be at least one landing for each story (2.44 to 3.66 m of elevation), and landings are recommended every 10 to 12 treads. Where practical, treads should be open, without the vertical risers to connect them. However, metal screens or kick plates should be fastened to the underside where needed to prevent injuries or avoid damaging equipment.

5.3.6.4.2 Risers. Riser height, or the distance between steps or stairs, should be uniform (between 125 and 200 mm, see Figure 72). The distance between steps and landings, if different from the uniform riser height, should also be between 125 and 200 mm.

5.3.6.4.3 Load carrying. When people carry loads weighing more than 9 kg, or where stairs are more than two stories high, use deep treads (300 mm) and low risers (125 mm).

5.3.6.5 Ramps.

5.3.6.5.1 General. Ramps make it possible for personnel to roll stock from one level to another. However, in situations where personnel must push or pull stock up ramps, the ramps should be elevated carefully to take into consideration human strength and safety. Ramps or inclines should be used for slopes under 20°. For slopes between 7° and 20°, consider using combination ramp/stairways. (See Figure 73.)

5.3.6.5.2 Pedestrian traffic. When pedestrian traffic uses ramps, handrails should be provided. There also should be traverse strips of non-skid material, at least 50 mm wide and 150 mm apart, over the entire length of the ramp. From the standpoints of space and speed, stairways carry pedestrian traffic more efficiently than ramps do.

MIL-HDBK-759B

A. Angle of rise:	Min	Max
B. Tread depth	240	300
C. Riser height:	125	200
D. Width (handrail to handrail)		
One-way stairs:	510	—
Two-way stairs:	1.2 m	—
E. Min. overhead clearance:	2 m	
F. Height of handrail:	760	910
G. Diameter of handrail:	30	75
H. Hand clearance:	45	—

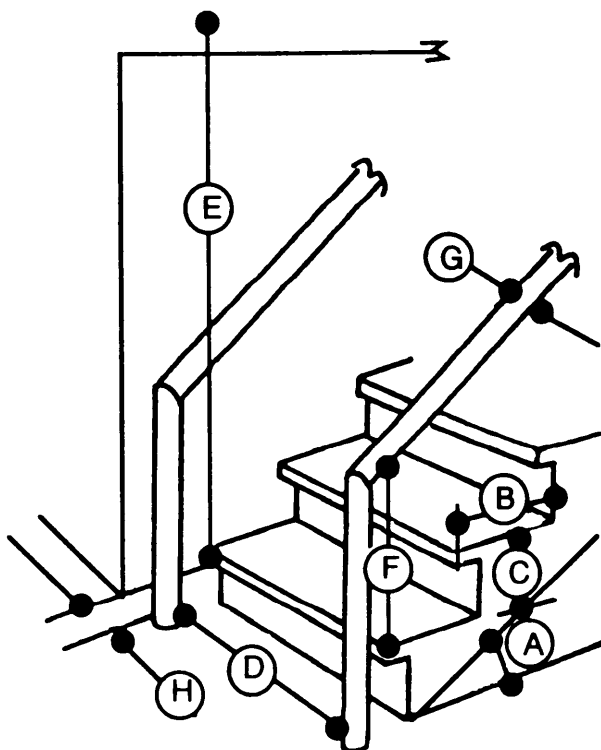

(in mm except where marked)

FIGURE 72. Stair dimensions

MIL-HDBK-759B

	<u>Min</u>	<u>Max</u>
A. Angle of rise:	----	20°
B. Height of handrails:	960mm	1.1m
C. Width: Determined by function and usage; particularly size of rolling stock and loads.		
D. Diameter of handrail:	25mm	75mm
E. Clearance around handrail:	50mm	----

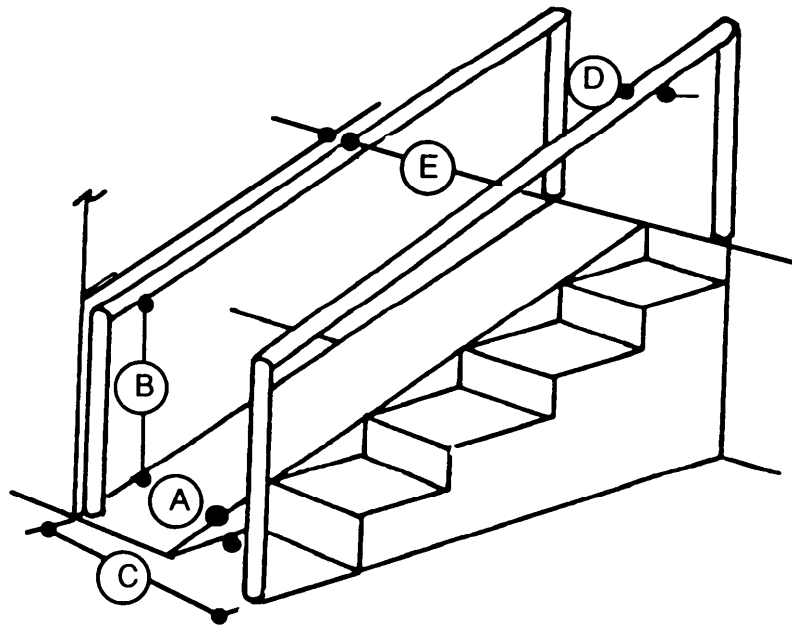

FIGURE 73. Ramp dimensions

MIL-HDBK-759B

5.3.7 Walkways and passageways

5.3.7.1 General. Corridor widths should be redesigned with consideration for the peak traffic load expected, direction of traffic flow, and number and size of entrances and exits in the area. To allow people to move without restriction, the minimum widths given in Figure 75 should be observed.

5.3.7.2 Clearance. Adequate clearance for personnel wearing bulky protective clothing and carrying equipment should be allowed. A person can move through a corridor 510 mm wide with some difficulty; however, a one-person or one-direction corridor should be at least 760 mm wide.

5.3.7.3 Floors. Corridors should have non-skid floors.

5.3.8 Doors.

5.3.8.1 General. Door dimensions should be as shown in Figure 74. Sills should usually be omitted, unless they are necessary for weather protection or ventilation control.

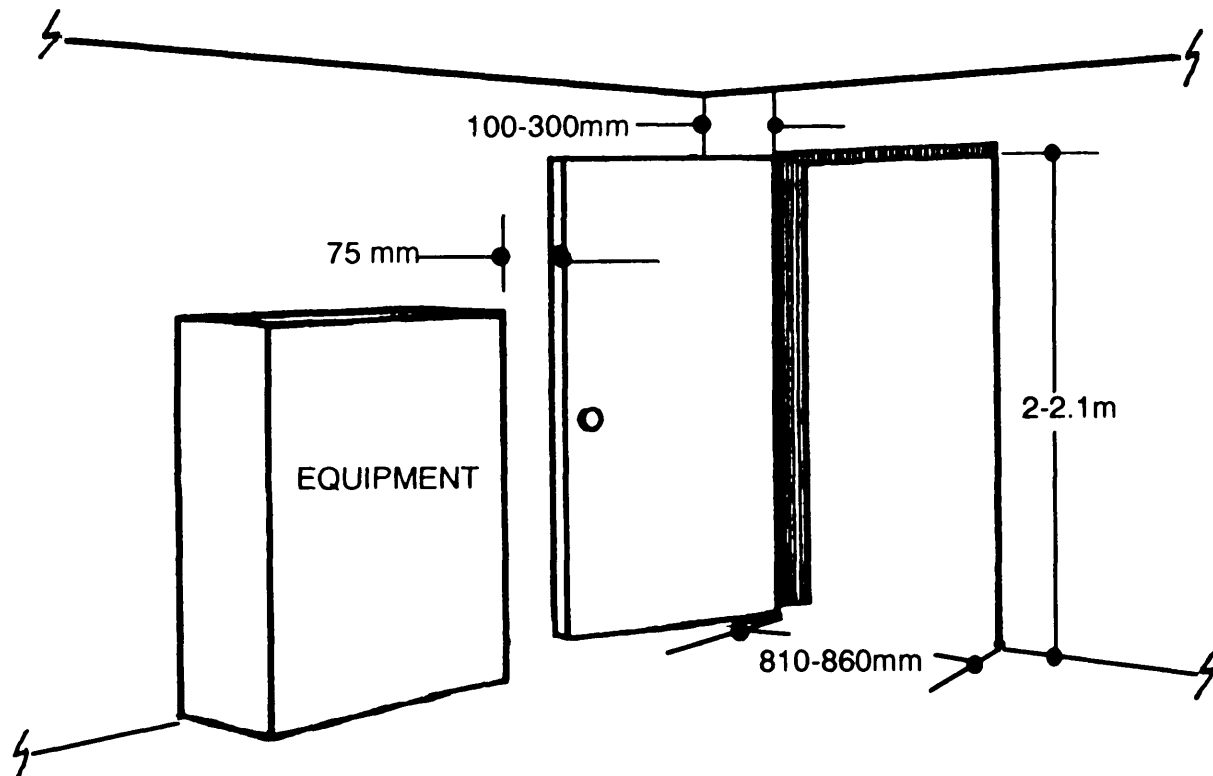

FIGURE 74. Door dimensions

MIL-HDBK-759B

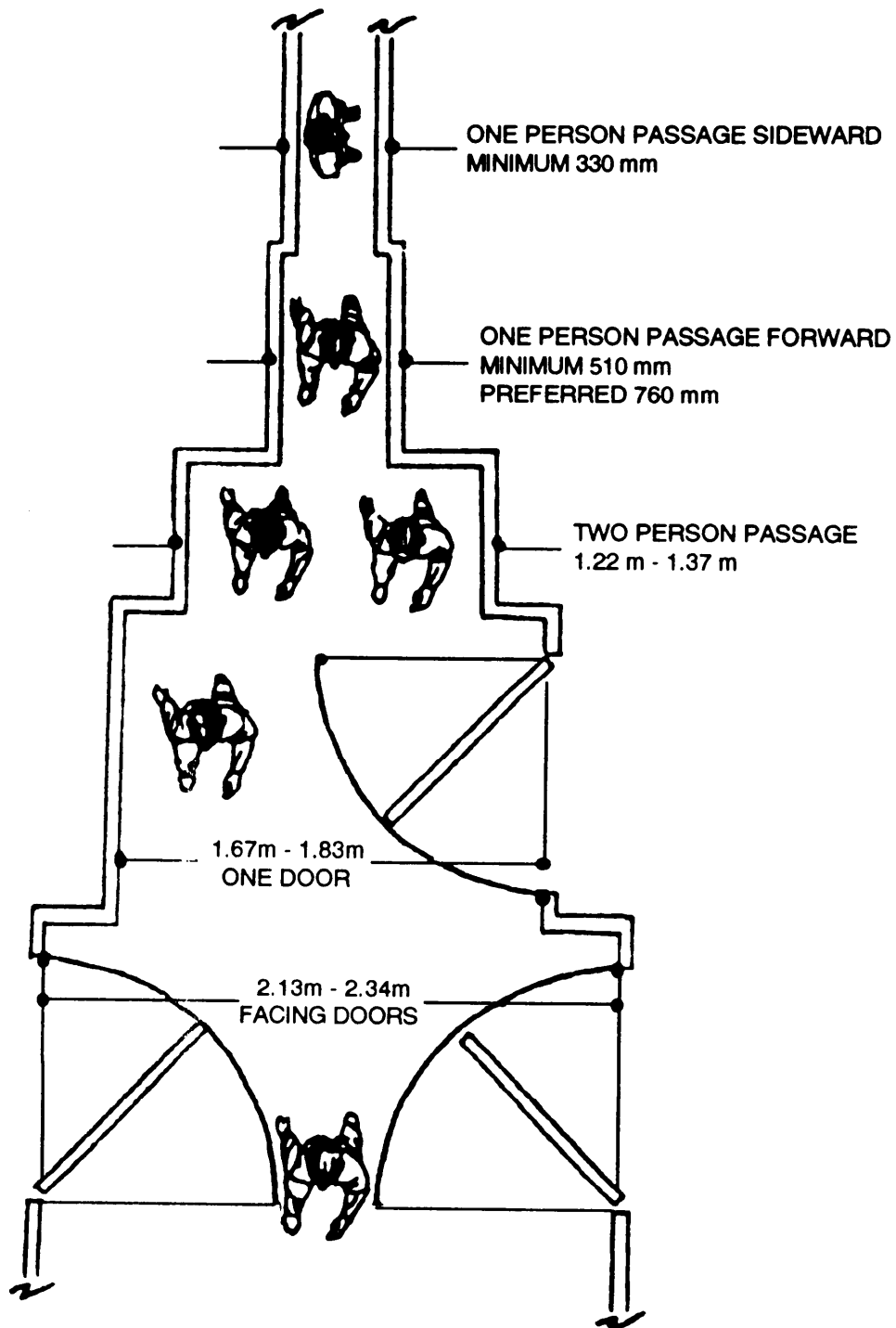

FIGURE 75. Walkway and passageway dimensions

MIL-HDBK-759B

5.3.8.2 Sliding doors. Sliding doors are recommended when large vehicles or large pieces of equipment must be moved into (or out of) compartments. Separate hinged doors should be inserted into sliding doors for personnel use.

5.3.8.3 Vertical and sliding doors. Vertical and sliding doors can be very useful in cramped spaces. However, they tend to jam when damaged by blast or collision; therefore, vertical and sliding doors should never be the only exit from an area. There should always be another way to escape.

5.3.9 Escape Hatches.

5.3.9.1 General. Escape hatches should be designed so they can be opened with one motion of the hand or foot. If personnel must use a handle or push button to open the hatch, its operating force should be less than 220 N.

5.3.9.2 Emergency hatches. If emergency hatches must be placed overhead, they should weigh 22.6 kg or less and they should open by force of gravity. All personnel except the weakest 5% of the population should be able to release and open these hatches.

5.3.9.3 Wall hatches. Wall escape hatches in vehicle-mounted shelters should be clear of all obstructions" (side panels or raised tailgate).

5.3.9.4 Dimensions. Escape hatch dimensions should be based on the work area from which personnel must escape, the equipment and clothing they will be wearing, and the environment they will enter.

Minimum and preferred dimensions for emergency hatches are:

	Minimum (mm)	Preferred (mm)
a. Rectangular hatch opening	405 x 610	510 x 710
b. Square hatch opening	460	560
c. Circular hatch opening	560	710

MIL-HDBK-759B

5.3.10 Platforms.

5.3.10.1 General. Platforms should be used where personnel must be raised to within optimal (or at least tolerable) working distance of equipment. Platforms should be designed with the considerations listed below.

- a. Measure at least 610 mm wide and 910 mm long.
- b. Leave both of the user's hands free for work.
- c. Provide continuous work surface around the work area or between related parts of it.
- d. Hold one or two persons (but no more).
- e. Have sufficient strength to hold the heaviest combination of personnel and equipment that it will ever be required to support, plus a safety allowance. (In calculating this load, assume each person weighs 113.4 kg.)
- f. Conform closely to the equipment surface it adjoins:
 - (1) Average conformation should be within 50 mm.
 - (2) Gaps greater than 150 mm should be avoided.
 - (3) Contact plates, cushions, bumpers, or pads should be used as necessary to protect equipment surfaces.

5.3.10.2 Portable platforms. Portable platforms should be constructed of lightweight material and be fully collapsible. Any platform on wheels should have brakes and wheel locks.

5.3.10.3 Equipment on platforms. When users must carry equipment onto a platform, access stairs should not be steeper than 35°. Provisions should be incorporated in the platform to support test equipment at convenient working levels.

5.3.10.4 Handrails and toeboards. Platforms should have handrails and toeboards around the outer edges. Screening and latticework may also be used (see Figure 76).

5.3.11 Guardrails and handrails.

5.3.11.1 General. Guardrails and handrails should meet the criteria of Figure 76.

MIL-HDBK-759B

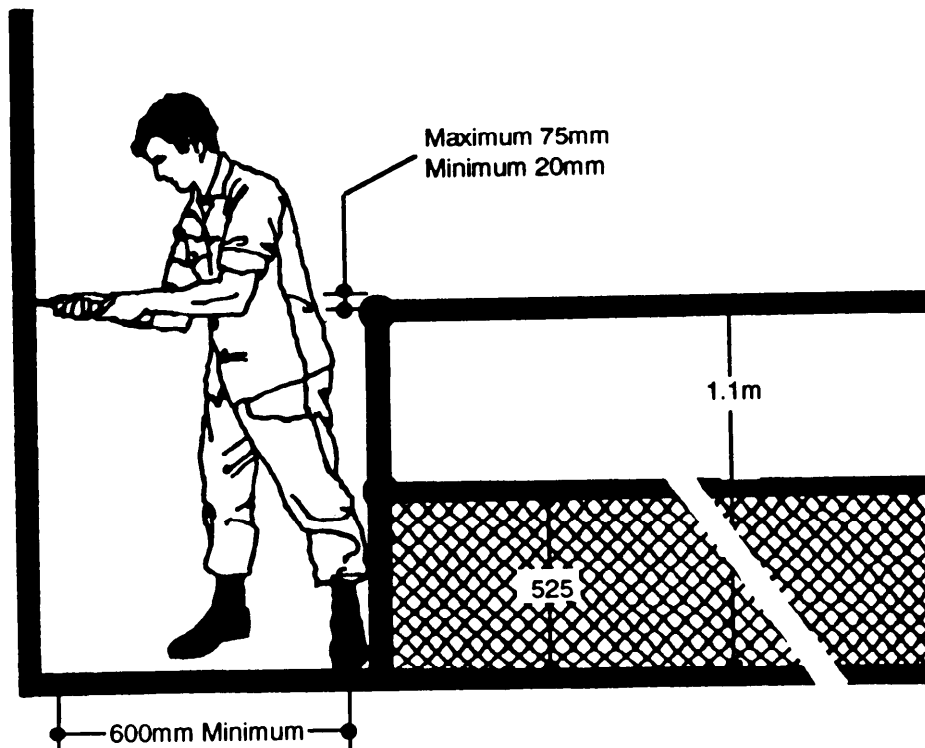

FIGURE 76. Guardrail and handrail dimensions

5.3.11.2 Uses. Guardrails and handrails should be used to:

- a. keep personnel from falling off raised work places by providing guardrails on all open sides,
- b. keep personnel from falling through floor openings or manholes,
- c. keep personnel within safe bounds when passing through hazardous areas
- d. help personnel climb inclines and stairs, and
- e. help personnel stabilize themselves when working in moving vehicles or around high winds, fog, ice, or other hazards.

MIL-HDBK-759B

5.3.12 Seated workspace.

5.3.12.1 General. The main objective of seat design is stabilizing the operator's body so that he can work efficiently (see Figure 77 and Table 54).

5.3.12.2 Cushioning. Chairs should be cushioned whenever operators must remain seated for more than an hour or more than 20% of the time. Uncushioned stools or benches are adequate for intermittent sitting, but they should conform to applicable criteria for seats. Good seat cushions should:

- a. have flat, firm shape, but with enough softness to deform,
- b. have resilient material under the cushion to absorb shocks,
- c. support body weight, primarily around the two bony points of the pelvis,
- d. tilt backward 5° to 7°, so the seat (rather than the user's muscles) supports the back,
- e. be shaped to follow the inward curve of the lower back, and provide adequate support for it, to relieve strain on the back muscles,
- f. avoid applying pressure under the thighs,
- g. use perforated or ventilated material, to prevent "hotness" or "sweatiness,"
- h. allow the sitter to shift positions. (Larger backrests are better, because more support area gives greater opportunity for changing positions.)

5.3.12.3 Armrests. Seats usually should have armrests so the elbows can help support some of the upper-body weight. These rests should be undercut to allow space for the hips and thighs. Where a console or panel has a tracking control, the armrest should support the operator's arm so he is in the same plane as the control. These rests should be removable, since they sometimes interfere with tasks the operator must perform.

MIL-HDBK-759B

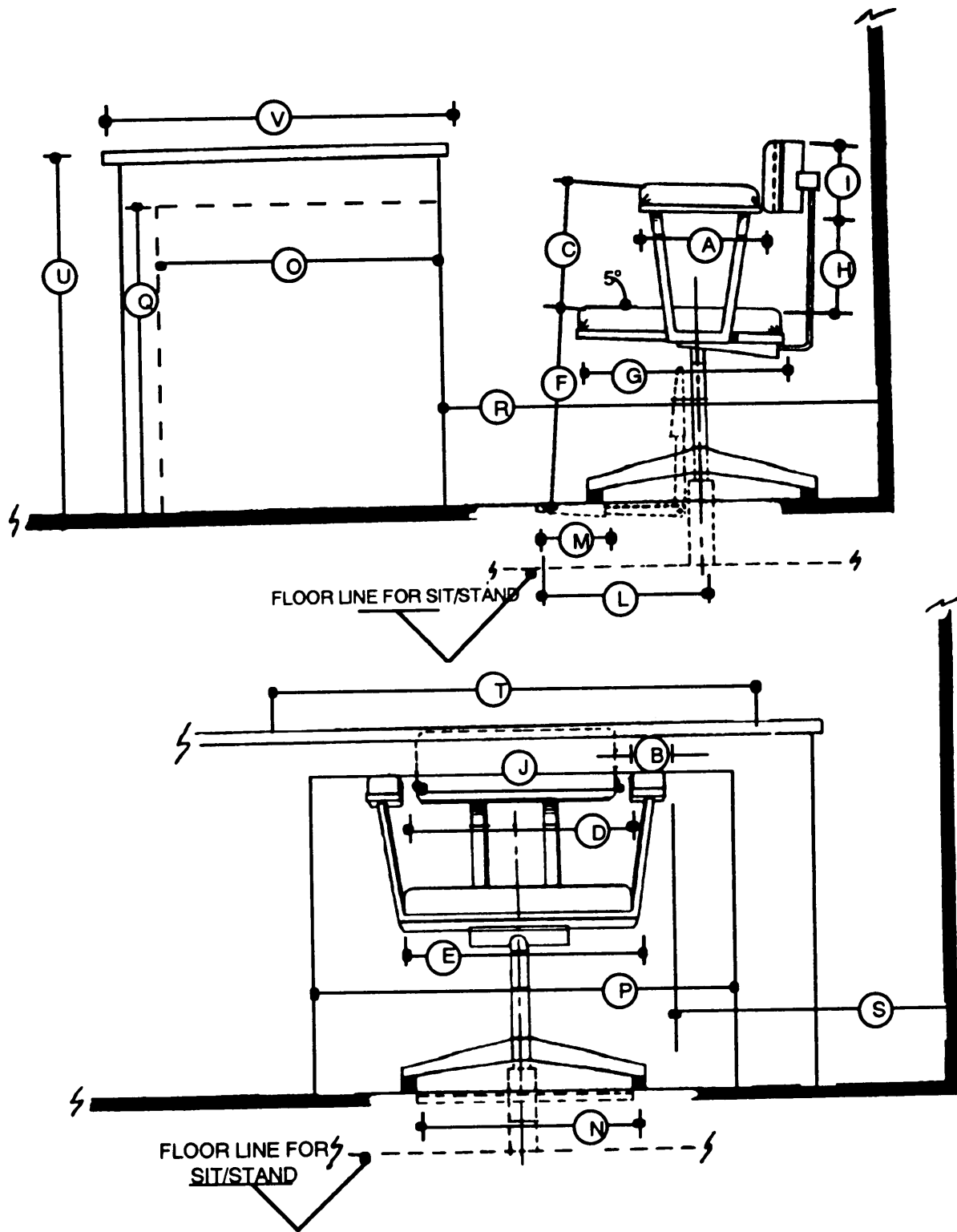

FIGURE 77. Seated workspace dimensions

MIL-HDBK-759B

TABLE 54. Seated workspace dimensions

	Fixed (mm)	Adjustment (mm)	
<u>Chair</u>			
Armrests:	A Length	255	
	B. Width	50	
	C. Height	215	
	D. Separation	460	
Seat:	E. Width	405	
	F. Height	460	+/-50
	G. Depth	405	
Backrest:	H. Space	150	+/-50
	I. Height	380	
	J. Width	405	
Footrests:	L, From center	180	
	M Width	150	
	N. Length	255	
<u>Workspace</u>			
	<u>Minimum</u>	<u>Preferred</u>	
O. Knee hole depth	460	-----	
P. Knee hold width	510	-----	
Q. Knee hole height (standard office)	635	-----	
R Desk to wall	810	-----	
S. Armrest to wall	610	-----	
T. Lateral work clearance			
(1) Shoulders	585	-----	
(2) Elbows	635	-----	
(3) Best overall	1m	-----	
U. Height of work surface	735	760	
V. Width of work surface			
(1) Elbow rest alone	100	200	
(2) Writing surface	305	405	
(3) Desk work area	-----	910	

¹Adjustment range. Adjustability is preferred for these dimensions.

MIL-HDBK-759B

5.3.12.4 Footrests. Whenever the operators must work for extended periods in seats higher than 460 mm or with work surfaces higher than 760 mm, they should have a footrest.

5.3.12.5 Temporary seats. If there is not enough space to include a permanent seat, consider a temporary "swing-away" seat (see Figure 78).

5.3.12.6 Advantages. Some advantages of having operators work while seated include those listed below:

- a. The operator can use more than one pedal control simultaneously.
- b. The operator can exert greater force on foot controls.
- c. It reduces fatigue.
- d. Operators have greater stability and better equilibrium when the equipment is vibrating or moving.

5.3.13 Standing workspace.

5.3.13.1 General. Whenever possible, workspace should be designed so operators can do routine, frequent, or short-term jobs while standing. A standing operator's workstation is not as limited to strict dimensional constraints as a seated operator's workstation because the standing operator can face in any direction and move from one position to another. If they are not free to do so and must remain in one position, the workspace should be designed so the operator can sit or take a sit-stand position.

5.3.13.2 Equipment placement. Any equipment that standing operators view or adjust only occasionally may be placed anywhere around them as long as it is at the proper height. This principle does not apply if the operator's attention must be concentrated in one particular direction most of the time.

5.3.13.3 Advantages. Some of the advantages of the standing position include those listed below:

- a. Operator's arms can apply more muscular force and make larger movements such as when operating a large lever.
- b. Operators can move to see and use components in areas that would be inaccessible to seated users.
- c. Operators can change positions, to reduce fatigue and boredom; many standing tasks can be done in either a sitting or a standing position.
- d. It saves space; the operators can use flat working surfaces, without knee room.

Recommended dimensions for standing workspace are given in Figure 79 and Table 55.

MIL-HDBK-759B

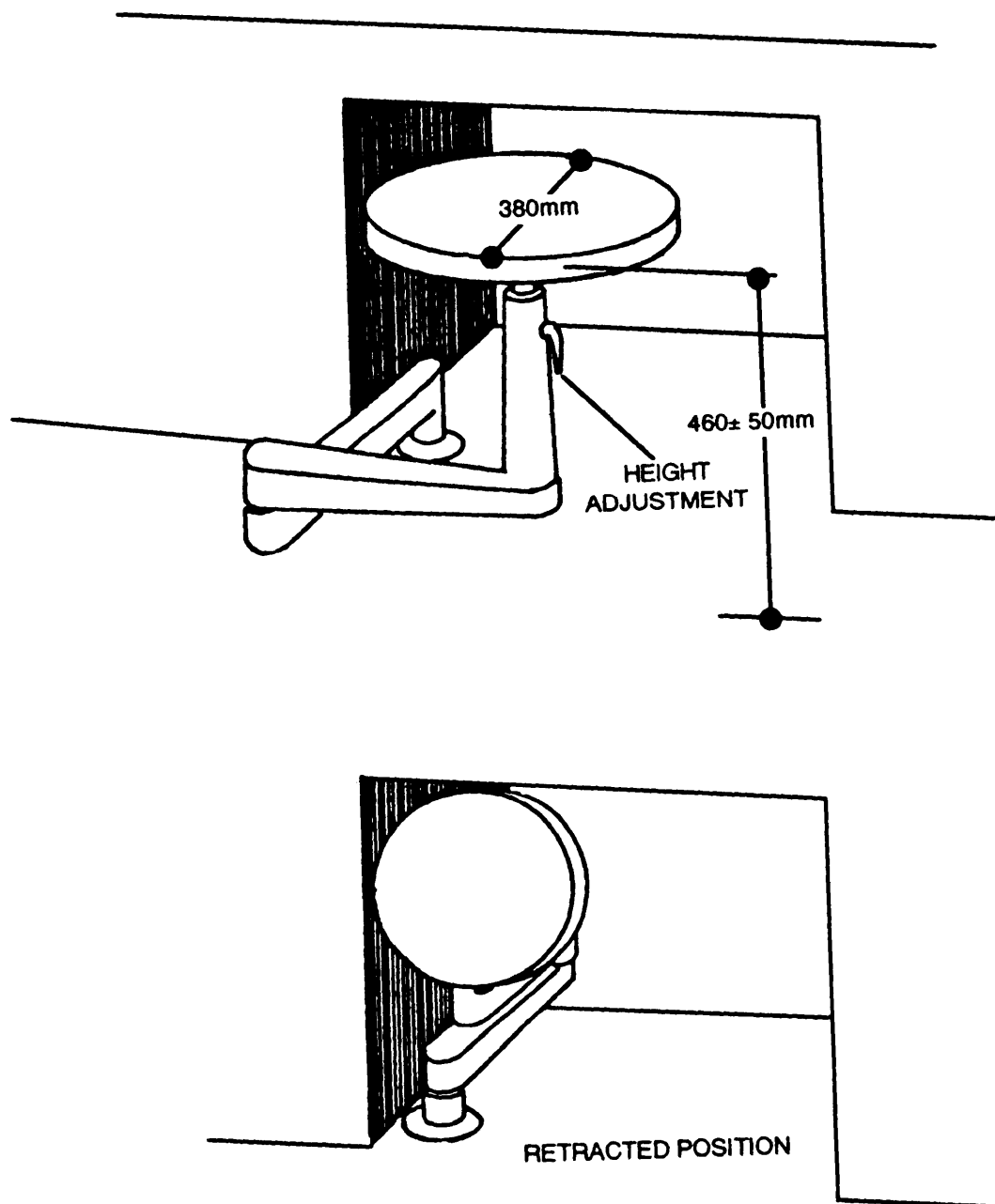

FIGURE 78. Swing-away seat for short-term operations

MIL-HDBK-759B

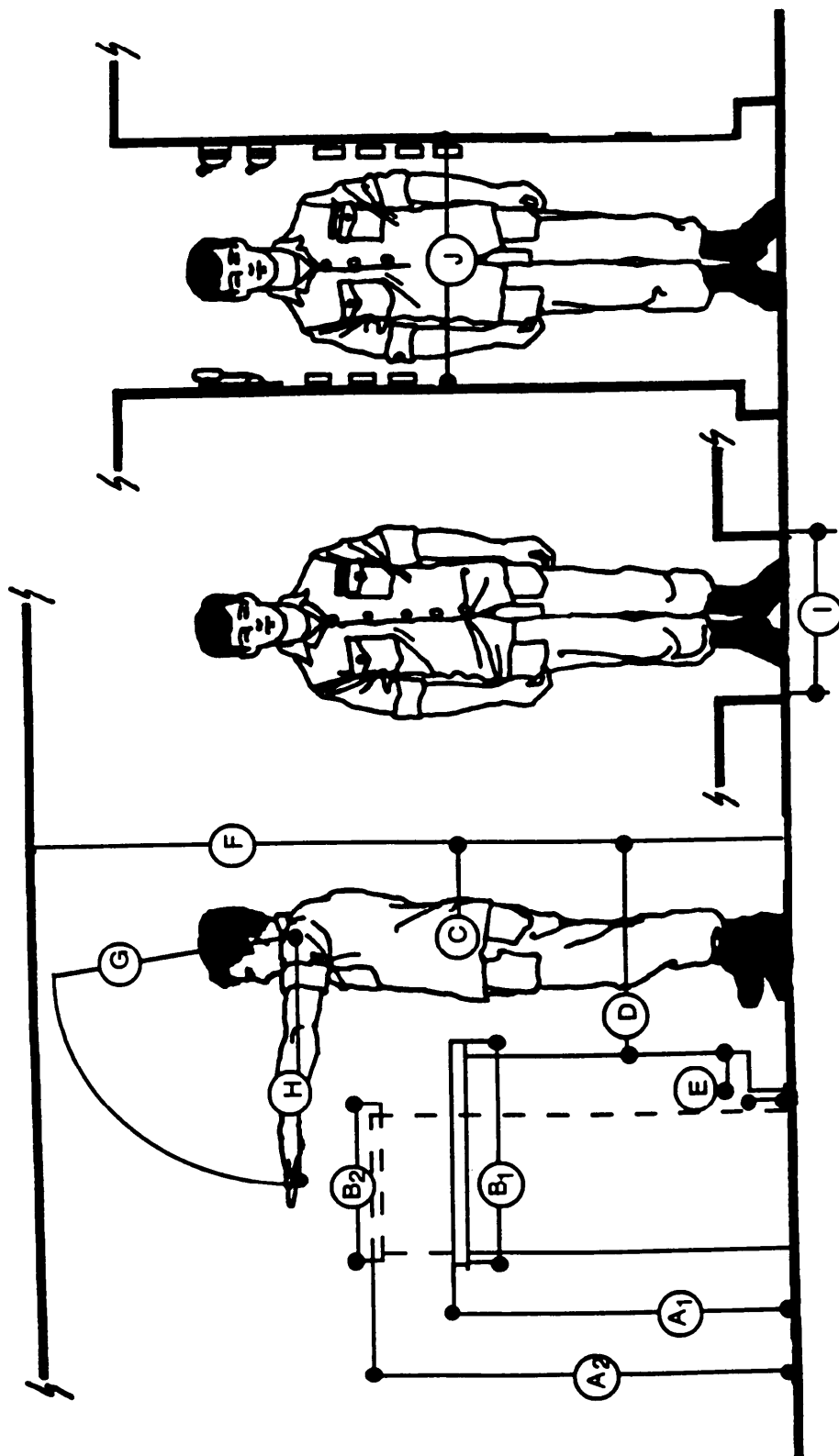

FIGURE 79. Standing workspace dimensions

MIL-HDBK-759B

TABLE 55. Standing workspace dimensions

<u>Work Benches</u>			
Standard Type	A.1 Height B.1 Width	0.91 m above floor 0.99 m	
Podium Type	A.2 Height B.2 Width	1.04 m above floor 0.91 m	
<u>Work Clearances (mm)</u>	<u>Minimum</u>	<u>Preferred</u>	<u>Arctic</u>
C. Passing body depth	330	380	380
D. Standing space	760	910	
E. Foot space	100X100		
F. Overhead clearance	1855	2030	1930
G. Maximum overhead reach		685	635
H. Maximum depth of reach		585	585
I. Walking space width	305	380	380
J. Passing body width	510	810	810

5.3.14 Mobile workspace. Because of space limitations, personnel sometimes have to perform tasks where they can neither sit nor stand. These cases should be minimized as much as possible. If personnel must work in or pass through such limited spaces, minimum necessary clearances are given in Figure 80 and Table 56.

5.3.15 Common working positions. Anthropometric data for the design and sizing of workspaces involving standing, sitting, stooping, kneeling and supine positions are presented in Figure 81 and Table 57. Fifth and 95th percentile values for men and women are given for various body dimensions in centimeters. Suitable allowances should be made for heavy clothing or protective equipment when required. Clearance dimensions should not be less than the 95th percentile values shown in Table 57.

MIL-HDBK-759B

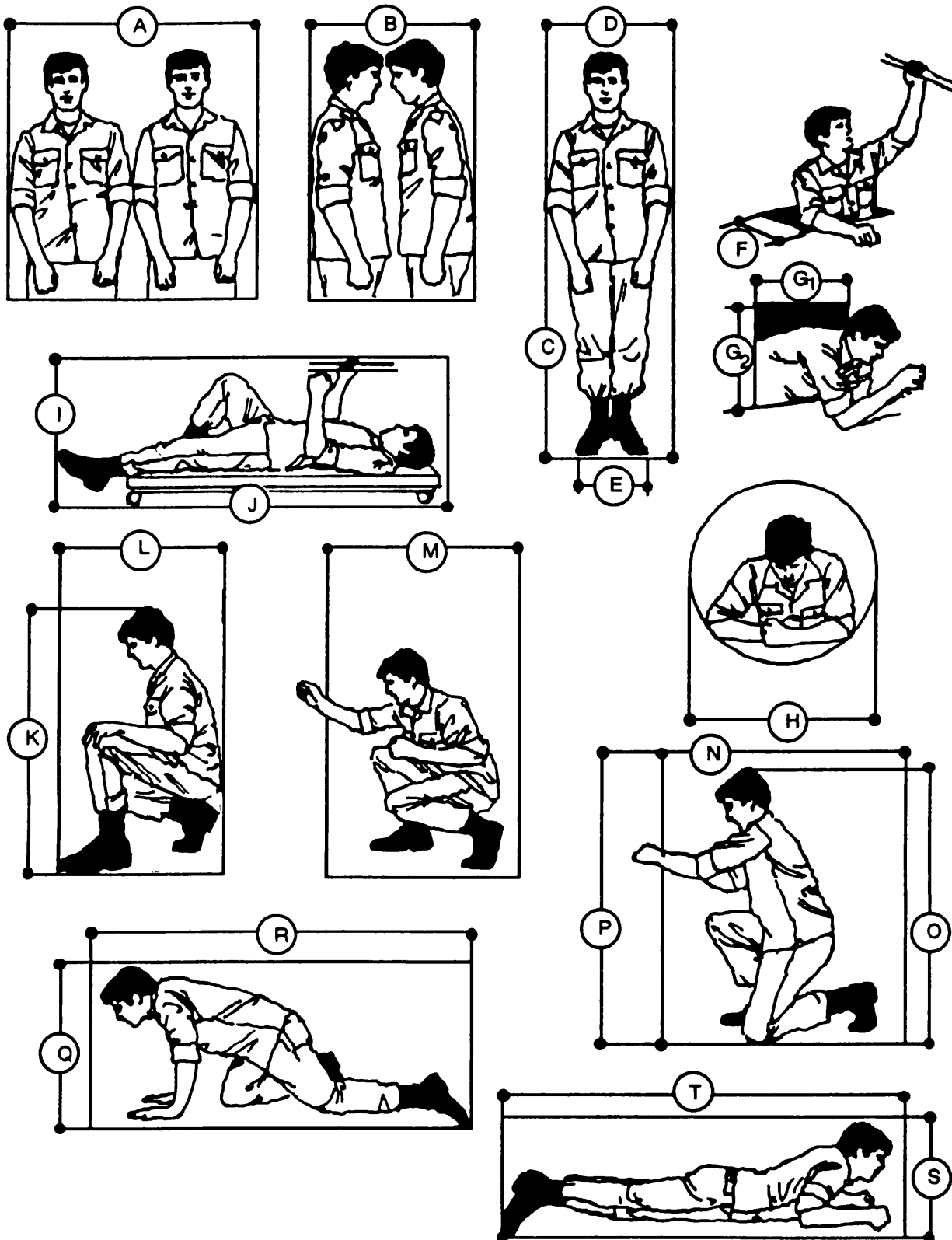

FIGURE 80. Mobile workspace dimensions

MIL-HDBK-759B

TABLE 56. Mobile workspace dimensions

	<u>Dimensions (mm)</u>		
	Minimum	Preferred	Arctic Clothed
A. Two men passing abreast	1.06m	1.37m	1.53m
B. Two men passing facing	760	910	910
Catwalk Dimensions			
C. Height	1.60m	1.86m	1.91m
D. Shoulder width	560	610	810
E. Walking width	305	380	380
F. Vertical entry hatch			
Square	459	560	810
Round	560	610	
G. Horizontal entry hatch			
Shoulder width	535	610	810
Height	380	510	610
H. Crawl through pipe			
Round or square	635	760	810
Supine workspace			
1. Height	510	610	660
J. Length	1.86m	1.91m	1.98m
Squatting workspace			
K. Height	1.22m	--	1.29m
L. Width	685	910	--
Optimum display area	685	1.09m	
Optimum control area	485	865	
Stooping workspace			
M. Width	660	1.02m	1.12m
Optimum display area	810	1.22m	--
Optimum control area	610	990	--
Kneeling workspace			
N. Width	1.06m	1.22m	1.27m
O. Height	1.42m		1.50m
P. Optimum work point	--	685	--
Optimum display area	510	890	
Optimum control area	510	890	--
Kneeling crawl space			
Q. Height	785	910	965
R. Length	1.50m		1.76m
Prone work or crawl space			
S. Height	430	510	610
T. Length	2.86m		--

MIL-HDBK-759B

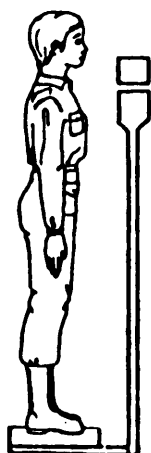

- ① WEIGHT (CLOTHED)
WEARING FATIGUES &
COMBAT BOOTS; STANDING
IN CENTER OF SCALE

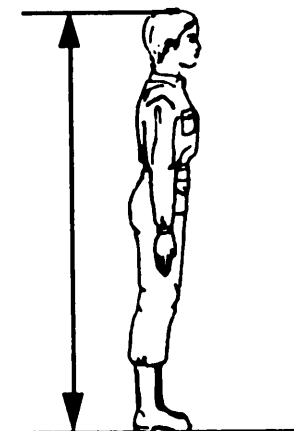

- ② STATURE (CLOTHED)
STANDING ERECT; HEELS
TOGETHER; WEIGHT DIS-
TRIBUTED EQUALLY ON BOTH
FEET. MEASURED FROM STANDING
SURFACE TO TOP OF HEAD

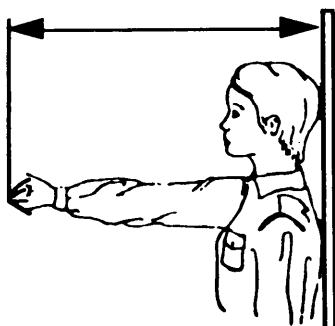

- ③ FUNCTIONAL REACH - STANDING
ERECT; LOOKING STRAIGHT
AHEAD; BOTH SHOULDERS AGAINST
WALL RIGHT ARM HORIZONTAL
MEASURED FROM WALL TO TIP OF
INDEX FINGER

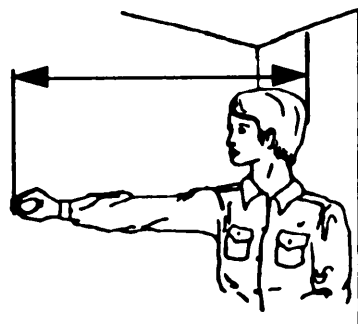

- ④ FUNCTIONAL REACH, EXTENDED-
STANDING ERECT; LOOKING STRAIGHT
AHEAD; RIGHT SHOULDER EXIENDED
AS FAR FORWARD AS POSSIBLE WHILE
BACK OF LEFT SHOULDER FIRMLY
AGAINST WALL; ARM HORIZONTAL
MEASURED FROM WALL TO TIP OF
INDEX FINGER.

FIGURE 81. Anthropometric data for workspaces

MIL-HDBK-759B

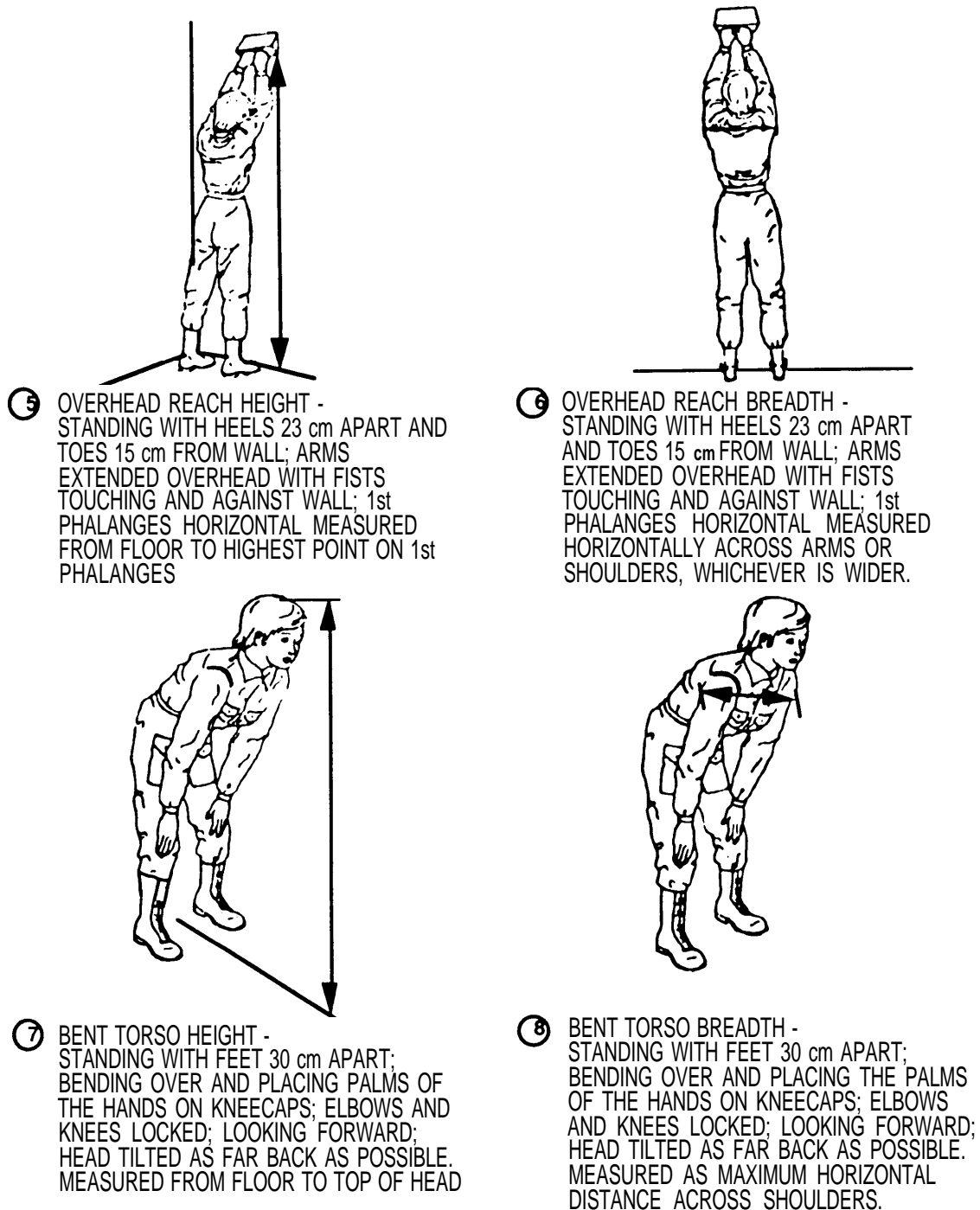
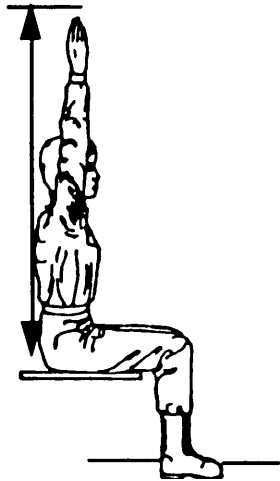
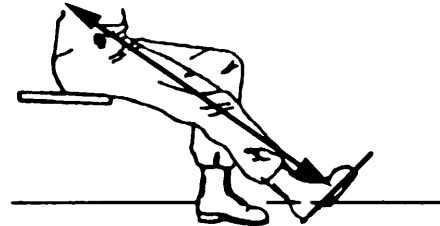

FIGURE 81. Anthropometric data for workspaces - continued

MIL-HDBK-759B



- ⑨ VERHEAD REACH, SITTING - SITTING ERECT; RIGHT SIDE AGAINST WALL; RIGHT ARM EXTENDED UPWARD WITH PALM FLAT AGAINST WALL AND FINGERS EXTENDED. MEASURED FROM SITTING SURFACE TO TIP OF MIDDLE FINGER.



- ⑩ FUNCTIONAL LEG LENGTH - SITTING ERECT ON EDGE OF CHAIR; RIGHT LEG EXTENDED FORWARD WITH KNEE STRAIGHTENED, MEASURED FROM HEEL ALONG AXIS OF LEG TO POSTERIOR WAIST.

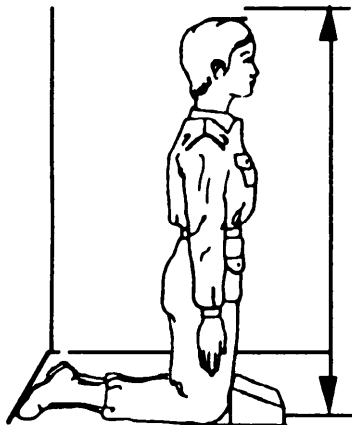

- ⑪ KNEELING HEIGHT - KNEELING WITH TOES EXTENDED AND LIGHTLY TOUCHING REAR WALL; TORSO ERECT WITH ARMS HANGING LOOSELY AT SIDES. MEASURED FROM FLOOR TO TOP OF HEAD.

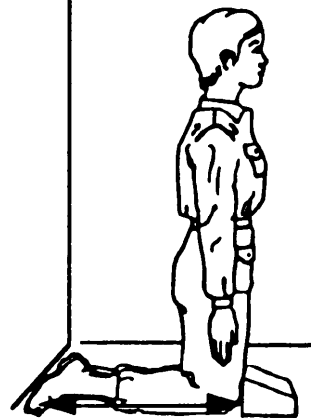

- ⑫ KNEELING LEG LENGTH - KNEELING WITH TOES EXTENDED AND LIGHTLY TOUCHING REAR WALL; TORSO ERECT WITH ARMS HANGING LOOSELY AT SIDES, MEASURED FROM WALL TO ANTERIOR PORTION OF BOTH KNEES.

FIGURE 81. Anthropometric data for workspaces - continued

MIL-HDBK-759B

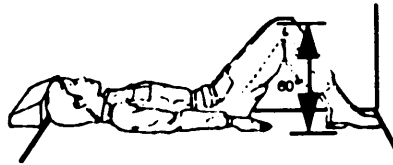

- ① BENT KNEE HEIGHT, SUPINE - LYING SUPINE; KNEES RAISED UNTIL ANGLE BETWEEN UPPER AND LOWER LEGS APPROXIMATES 60°; TOES LIGHTLY TOUCHING WALL MEASURED FROM FLOOR TO HIGHEST POINT ON KNEES.

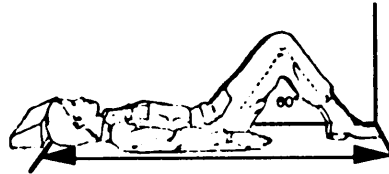

- ① HORIZONTAL LENGTH, KNEES BENT - LYING SUPINE; KNEES RAISED UNTIL ANGLE BETWEEN UPPER AND LOWER LEGS APPROXIMATELY 60°; TOES LIGHTLY TOUCHING WALL MEASURED FROM THE WALL TO TOP OF HEAD.

FIGURE 81. Anthropometric data for workspaces - continued

MIL-HDBK-759B

TABLE 57. Anthropometric data for common working positions

	PERCENTILE VALUES IN CENTIMETERS			
	5TH PERCENTILE		95th PERCENTILE	
	MALE	FEMALE	MALE	FEMALE
1. WEIGHT--CLOTHED (KILOGRAMS)	58.6	48.8	90.2	74.6
2. STATURE--CLOTHED	168.6	156.8	189.0	178.7
3. FUNCTIONAL REACH	72.6	64.0	86.4	79.0
4. FUNCTIONAL REACH, EXTENDED	84.2	73.5	101.2	92.7
5. OVERHEAD REACH HEIGHT	200.4	185.3	230.3	215.1
6. OVERHEAD REACH BREADTH	35.2	31.5	41.9	37.9
7. BENT TORSO HEIGHT	125.6	112.7	149.9	138.6
9. BENT TORSO BREADTH	40.9	36.8	48.3	43.5
9. OVERHEAD REACH, SITTING	127.9	117.4	146.9	139.4
10. FUNCTIONAL LEG LENGTH	110.6	90.6	127.7	118.6
11. KNEELING HEIGHT	121.9	114.5	136.9	130.3
12. KNEELING LEG LENGTH	63.9	59.2	75.5	70.5
13. BENT KNEE HEIGHT, SUPINE	44.7	41.3	53.5	49.6
14. HORIZONTAL LENGTH, KNEES BENT	150.8	140.3	173.0	163.8

5.4 Environment.

5.4.1 Environmental factors.

5.4.1.1 General. There are three major categories of environmental factors which affect equipment design.

- a. Environmental factors that design can control (illumination, ventilation rate, and temperature).
- b. Environmental factors that design cannot control (amount of solar radiation, dust, mud, and rain).
- c. Environmental factors that are a function of design (noxious substances, vibration, and noise).

5.4.1.2 Environmental extremes. To maximize the effectiveness of the soldier-machine weapons system, the designer should consider the environmental extremes to which the system will be subjected and the effect on performance. Army Regulation 70-38, Test and Evaluation of Materiel for Extreme Climatic Conditions, specifies the climatic ranges normally encountered under operational conditions in world-wide geographical areas during all seasons of the year. Military materiel should be capable of sustained operations within the climatic extremes specified in the materiel requirements documents. When deviations from the stated tolerable conditions are

MIL-HDBK-759B

necessary, consequences should be reconsidered in design to prevent adverse effects such as:

- a. criteria for protective clothing or devices which affect the mobility, reach, workspace, or access size, for efficient and effective operation and maintenance,
- b. reduced human performance,
- c. borderline conditions which, though they have little or no direct effect on equipment, may seriously impair the ability of the operator or technician to perform effectively, and
- d. conditions which contribute to longer maintenance time or increased maintenance errors, oversights, and erroneous decisions, and which are detrimental to system availability and performance.

The above adverse effects can sometimes be minimized through the use of alternatives such as:

- a. rotation of personnel at their workstations,
- b. decreased workloads,
- c. increased workspace allotments,
- d. individual protective measures or supplemental equipment,
- e. personnel selection and training, and
- f. acclimation of operating personnel.

5.4.2 Hot environment.

5.4.2.1 General. Five basic factors that determine the degree of heat stress exerted by the environment are air temperature, humidity, air movement, heat radiation and direct conduction from objects.

5.4.2.2 Effective temperature. The effective temperature (ET) of an environment is an empirical thermal index that illustrates how combinations of dry bulb air temperature, humidity, air movement, and clothing affect people. Numerically, it is equal to the temperature of still, saturated air which would induce the same sensation (see Figure 82). This chart is based on wearing customary indoor clothing and doing sedentary or light muscular work. It does not include any additional heat stress from special purpose clothing such as gas masks, chemical protective clothing, or body armor. Likewise, it does not consider radiant heat input such as radiation from the sun or equipment components.

MIL-HDBK-759B

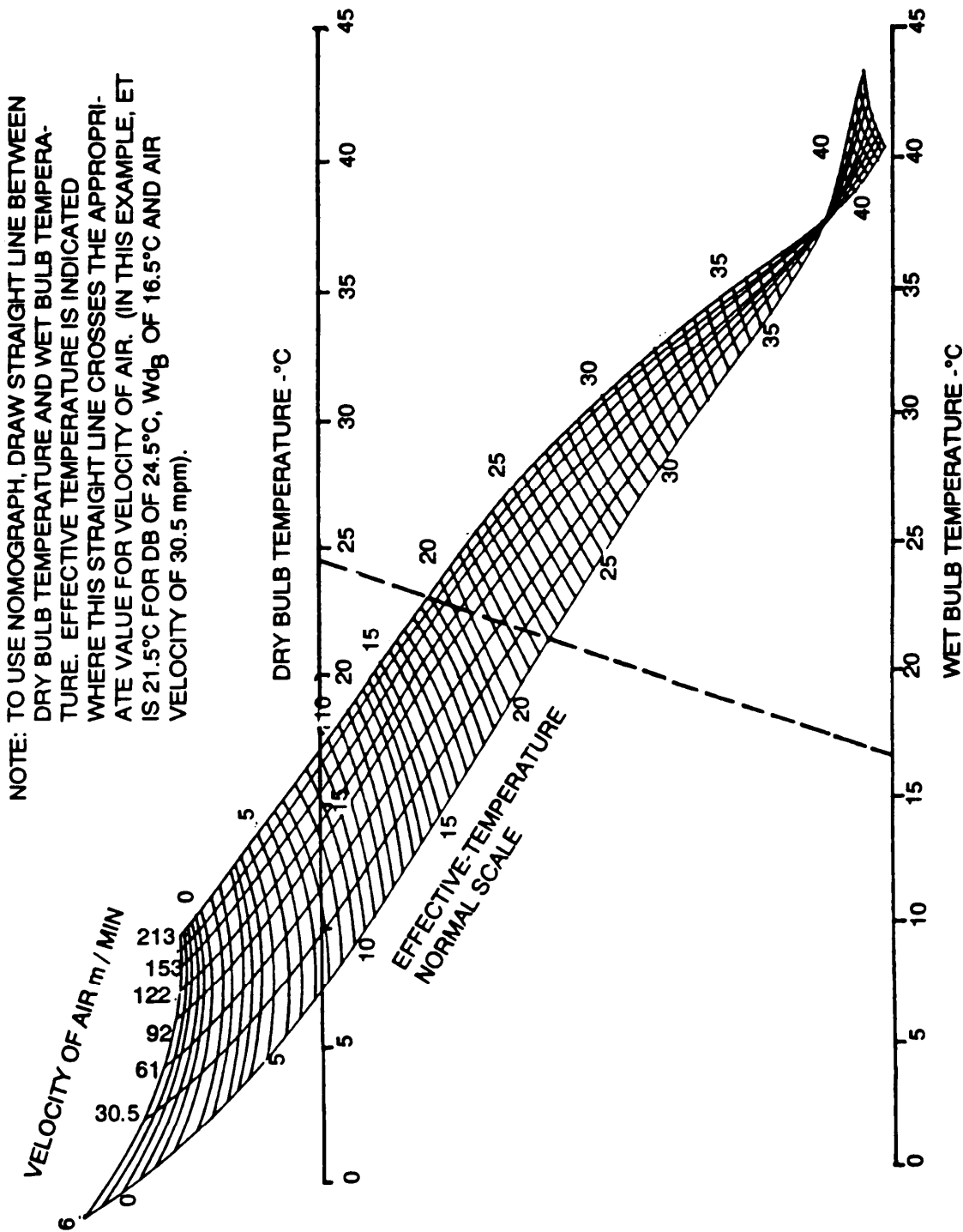

FIGURE 82. Deriving effective temperature

MIL-HDBK-759B

5.4.2.2.1 Effective-temperature ranges. The effective-temperature ranges are flexible because they vary according to the amount of work activity. Dry bulb temperature should be decreased by 1.7°C for each 29 watts per hour increase in metabolic rate above the resting 117 watts per hour level, with relative humidity kept at or below 60% to allow sufficient evaporation to avoid perspiring. In general, the ranges should be extended upwards for tasks requiring minimal physical effort and downward for tasks requiring continuous muscular exertion.

- a. An effective temperature of 29.5°C should be considered the maximum limit for reliable human performance.
- b. Minimum temperature requirements are dependent upon the tasks to be performed in specific applications. Heating should be provided within personnel enclosures used for detailed work or occupied during extended periods of time if the dry bulb temperature drops below 10°C.
- c. Prolonged exposure of an ungloved person to effective temperatures below 13.0°C often results in “stiffening” of fingers, which degrades performance in tasks requiring manual dexterity.
- d. A person wearing arctic clothing should not be exposed, while sitting quietly, to temperatures higher than 15.5°C; a temperature of 1.5- 7.0°C is optimal.
- e. In providing for heating and cooling of enclosed areas, it is important that the temperature of the enclosed area be held relatively uniform. The temperature of the air at floor level and at head level should not differ significantly (by more than 5.5°C).
- f. Relative humidity above 30% and below 70% is considered adequate if the optimum temperature range for physical comfort is maintained.
- g. Side walls of the compartment should be kept at equal temperatures in so far as possible; however, temperature differences of 11°C or less do not significantly degrade comfort.

5.4.2.2.2 Optimum temperatures. The optimum temperatures for personnel varies according to the nature of the tasks, the conditions under which the tasks are performed, and the clothing personnel are wearing. The optimum range of effective temperature for accomplishing light work while dressed appropriately for the season or climate is 21 - 27°C in a warm climate, or during summer, and 18- 24°C in a colder climate, or during winter. Effective temperature for the environment may be derived from Figure 83.

MIL-HDBK-759B

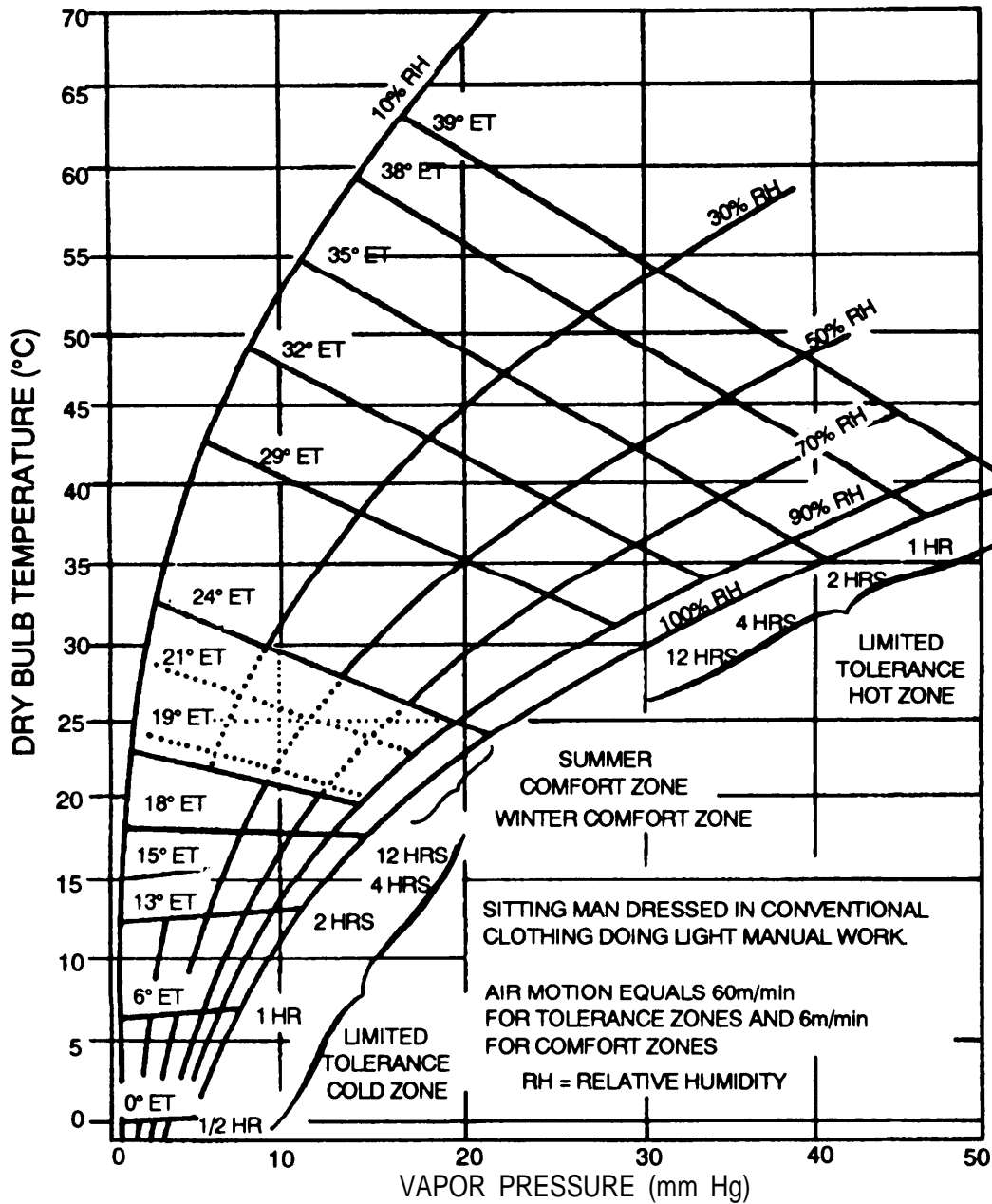

FIGURE 83. Summer and winter comfort zones and thermal tolerance for inhabited compartments

MIL-HDBK-759B

5.4.2.3 Measurement methods. Conventional methods for measuring environmental stress include the ordinary dry bulb thermometer, wet bulb thermometer, and “black globe” thermometer. However, dry bulb temperature does not include the effects of humidity, air movement, or radiation. Wet bulb is a better index since it includes humidity as well as air temperature but is not a good index of heat stress imposed by radiation. Radiant heat can most easily be determined by the “black globe” thermometer.

5.4.2.3.1 Wet bulb globe temperature. The Wet Bulb Globe Temperature (WBGT) index is more applicable than the effective-temperature index in the range beyond the comfort and discomfort zones of heat stress. WBGT incorporates, as a major element, the evaporative cooling available to a “natural” wet bulb thermometer (one with a wettable wick, exposed to ambient air motion and extending into a water reservoir) under whatever air motion exists in the environment; this contrasts with the conventional, psychometric wet bulb thermometer, where air is moved across the wetted bulb either by a fan or by “slinging” the thermometer at the end of a handle. Because of this difference, the natural (non-psychometric) wet bulb temperature is a better representation of the actual evaporative cooling available to a sweating person. The WBGT index is calculated as:

$$WBGT = 0.7T_{WBnp} + 0.2T_g + 0.1 T_A$$

where T_g , representing the radiant heat is the temperature at the interior center of a 15.2 cm, black globe and T_A is a non-psychometric, but shaded dry bulb (air) temperature. In the absence of a radiant heat source (solar, engine, furnace) a modified Wet-Dry (WD_{85}) index should be used where:

$$WD_{85} = 0.85T_{WBnp} + 0.15T_A$$

Use of a psychometric, rather than shaded dry bulb for T_A makes little difference in either WBGT or WD ; however, use of the psychometric wet bulb for T_{WBnp} can result in serious discrepancy, unless wind velocity approaches or exceeds 3 m/s or ambient relative humidity approaches 100%. Note that regulations for control of heat illness reference WBGT, while provisions for comfort and performance decrements typically reference effective temperature.

5.4.2.4 Limited thermal tolerance zone. Where hard physical work is required for more than two hours, an environment should be provided not exceeding a WBGT or WD index of 25°C. A Wet Bulb Globe Temperature (WBGT or WD index) value of 25°C is considered the threshold for unacclimated troops (less than 3 weeks of work in the heat in the weeks preceding the exposure). Physically fit troops acclimate to work in the heat most rapidly (3 to 4 days of 100 minutes of physical work in the heat each day) and stay acclimated (for 3 or more weeks after cessation of work in the heat). Less fit, unacclimated individuals may not initially be able to complete a full 100 minutes of work in the heat and will have to be brought to this level over a period of 6 to 8 days. Unacclimated troops should not be required to perform hard physical work for more than two hours at WBGTs above 25°C while fully-acclimated troops can work up to 8 to 12 hours a day at WBGTs in the 27°C range. In these cases, water intake should be maximized, by command, if necessary. At these levels of WBGT, troops will

MIL-HDBK-759B

lose one quart of sweat per hour. This represents a dehydration (loss of body fluids) amounting to about 1.5% per hour and a 5 to 6% level of dehydration is incompatible with sustained, unimpaired performance of hard physical work. Note also that clothing which reduces evaporation of sweat from the skin reduces the tolerable WBGT limits; wearing body armor effectively lowers the above WBGT limits by about 3°C, complete chemical protective uniforms lower them by about 5°C, while partial CB protection, raincoats, and firemen's turnout coats are intermediate (lower WBGT by 4°C). Further details are provided in TB MED 175. While a 1°C lower threshold WBGT may be appropriate for women in general, a very fit, acclimated female may experience no more difficulty with heat exposure than a male of average military fitness. Emphasis on physical fitness and acclimatization to heat will be a more effective approach than emphasis on intrinsic differences in heat tolerance between men and women.

5.4.2.5 Humidity. Within personnel enclosures such as mobile vans and shelters, permanent and semi-permanent shelters utilized for detail work or occupied for extended periods, the humidity values should approximate 45% relative humidity at 21 °C. This value should decrease with rising temperatures, but should remain above 15% to prevent irritation and drying of body tissues such as eyes, skin, and respiratory tract (see Figure 83).

5.4.2.6 Air Conditioning. Air conditioning should be provided if the effective temperature within personnel enclosures (vans, shelters) utilized for detail work during prolonged periods exceeds 29.5°C. These systems should be designed such that cold air discharge is not directed on personnel.

5.4.2.7 Ventilation. Adequate ventilation should be assured by introducing fresh air into any personnel enclosure. If the enclosure volume is 4.25 m³ or less per person, a minimum of 0.85 m³ of ventilation air per minute should be introduced into the enclosure; approximately two-thirds should be outdoor air. For larger enclosures, the air supply per person may be in accordance with the curves in Figure 84. Air should be moved past personnel at a velocity not more than 30 m per minute. Twenty meters per minute is preferable. Under NBC conditions, ventilation or other protective measures should be provided to keep gases, vapors, dust, and fumes within the Permissible Exposure Limits specified: 29 CFR 1910 (Permissible Exposure Limits), the American Conference of Governmental Industrial Hygienists (Threshold Limit Values), or those governed by specialized standards (carbon monoxide) applicable to military unique equipment, systems, or operations. Intakes for ventilation systems should be located to minimize the introduction of contaminated air from such sources as exhaust pipes (see 5.4.4.2.2).

MIL-HDBK-759B

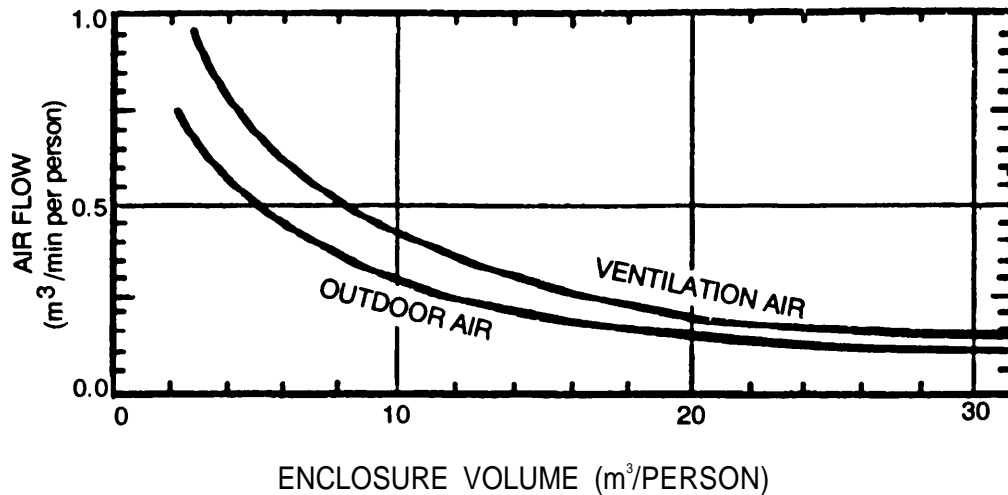

FIGURE 84. Ventilation values for larger enclosures

5.4.3 Cold environment.

5.4.3.1 Windchill. The windchill scale has been derived from the rate of freezing water influenced by ambient temperature and wind. Figure 85 depicts the relationship between temperature and wind for various windchill values.

5.4.3.1.1 Human reaction to windchill. A qualitative description of human reaction to windchill values to exposed skin includes:

<u>Windchill Value</u>	<u>Human Reaction</u>
100	Warm
200	Pleasant
800	Cold
1000	Very Cold
1200	Bitterly Cold
1400	Exposed Flesh Freezes

The above reaction should not be taken to indicate that freezing of exposed flesh does not occur below a windchill value of 1400. In fact, during the Korean campaigns, significant numbers of cold injury occurred at windchill values between 900 and 1000. The discrepancy presumably occurs because the freezing of flesh at dry condition temperatures (about the 1400 windchill level) differs from the freezing of flesh at wet condition temperatures (possibly as low a windchill value as 800). As a rule of thumb, if personnel are exposed to a Windchill Index (WI) of 1200 or above while operating equipment, they should be protected. Windchill indices this large are common even in temperate climates.

MIL-HDBK-759B

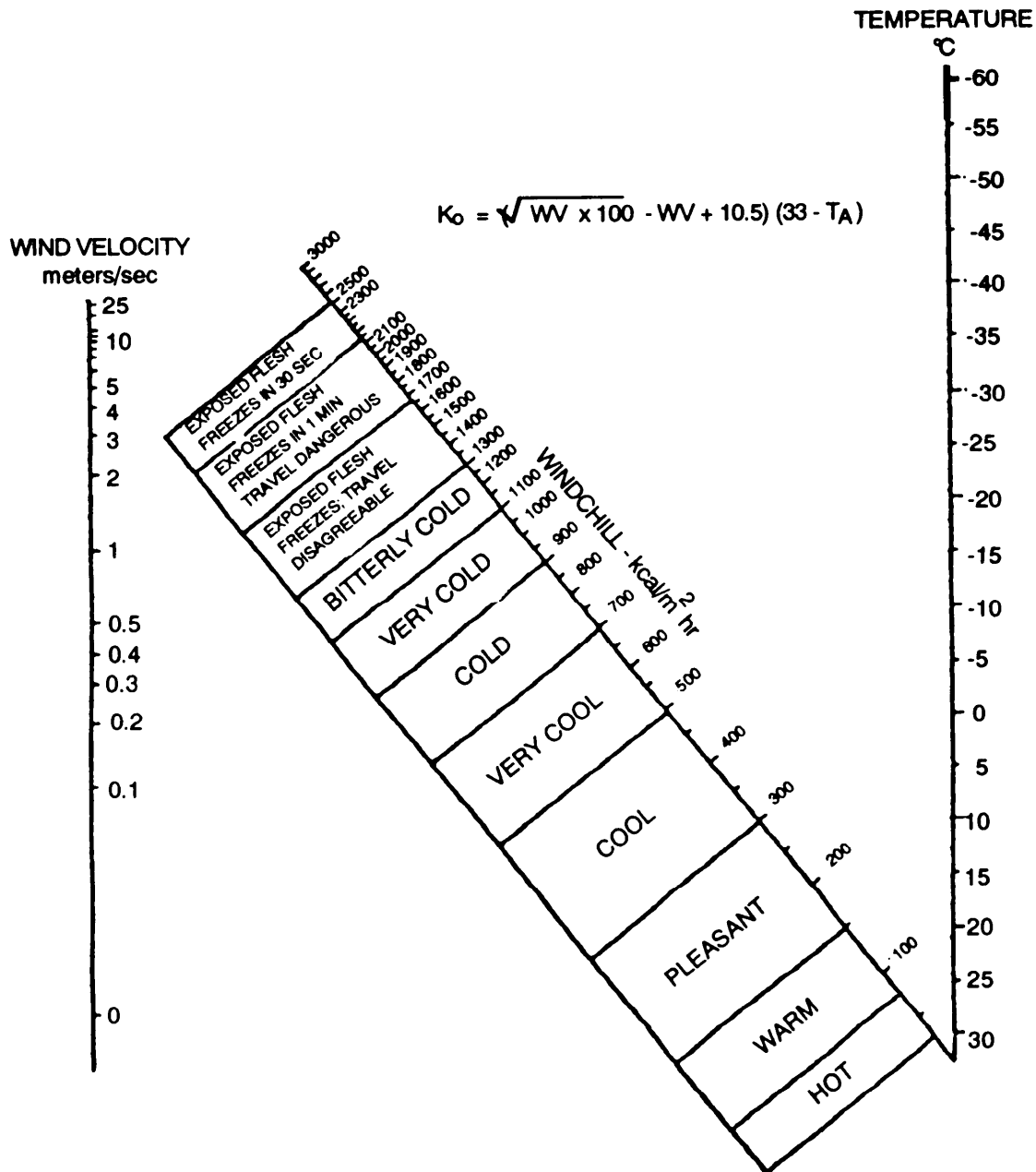

In outdoor cold weather, the wind velocity has a profound, sometimes decisive, effect on the hazard to men who are exposed. The windchill concept dramatizes this by providing a means of quantitative comparison of various combinations of temperature and wind speed. Note for example that -45°C with an air movement of 0.045 m/s has the same windchill value, and therefore is predicated to produce same sensation on exposed skin as -8°C with a wind of only 0.45 m/s or -10°C with a wind of 2.2 m/s . The windchill index does not account for physiological adaptation or adjustments. It is based on field measurements of the rate of cooling of a container of water by Paul Siple during World War II.

FIGURE 85. Windchill chart.

MIL-HDBK-759B

5.4.3.1.2 Wind and windchill. The WI relates the amount of heat actually lost by a person to the wind velocity and temperature. In evaluating a windchill hazard, designers should consider air movement at personnel positions. Figure 86 gives the cooling power of wind expressed as "Equivalent Chill Temperature." Frostbite can occur even in relatively warm temperatures if wind penetrates the layer of insulating air around the body to expose body tissue.

5.4.3.2 Mobile personnel enclosures (shop vans, shelters). Heating should be provided within mobile personnel enclosures utilized for detail work or occupied during prolonged periods of time to maintain interior dry bulb temperature above 10°C.

5.4.3.3 Permanent and semi-permanent personnel enclosures (Shop, offices). Heating should be provided within permanent and semi-permanent personnel enclosures utilized for detail work or occupied for prolonged periods of time to maintain interior dry bulb temperature of 18°C. The heating system should have provisions for regulating (shutters, louvers, fan-speed controls, fuel-proof carburetor) the amount of heat it delivers and be designed such that hot-air discharge is not directed on personnel.

5.4.4 Vehicle design thermal considerations.

5.4.4.1 Vehicular heat sources. In a buttoned-up vehicle exposed to the sun, the air temperature within rises above the outside temperature. Power-train and subsystem components, which are heated to a high temperature when the vehicle is in operation is one source of heat. The highly localized heat from power-train components should be insulated from the fighting compartment to prevent imposing an excessive surface contact or ambient heat load upon the crew members. Solar radiation, which is distributed over the surfaces exposed to the sun, is another source of heat. The rate of solar radiation varies throughout the day, reaching a maximum of approximately 945 watts/m² per hour on a horizontal surface. Assuming complete absorption and equal transmission of the heat to the inside and outside, the total amount of solar heat transmitted to the inside of an armored fighting vehicle can amount to a maximum of approximately 3,520 watts per hour. Ventilation and/or air conditioning should be provided to reduce this heat load.

5.4.4.1.1 Total heat load. Designers should consider compartment wall temperatures, the moisture content of the air, and the rate of air movement as well as the air temperature when determining the total heat load. For example, the air temperature inside an armored-vehicle fighting compartment (engine idling) on a moderately clear, midsummer day has been measured at 50°C with an outside air temperature of 29.5°C. In contrast, on a continuously clear, day with a maximum air temperature of 37°C, the fighting compartment wall temperatures reached 60.5°C. In the California desert, interior wall temperatures in a buttoned-up, stationary vehicle fighting compartment rose to 65.5°C (outside air temperature was 40°C) and while

MIL-HDBK-759B

COOLING POWER OF WIND EXPRESSED AS "EQUIVALENT CHILL TEMPERATURE"																						
WIND SPEED		TEMPERATURE (°C)																				
M/SEC	4	2	-1	-4	-7	-9	-12	-15	-18	-20	-23	-26	-29	-32	-34	-37	-40	-43	-46	-48	-51	
CALM																						
2.2	2	-1	-4	-7	-9	-12	-15	-18	-20	-23	-26	-29	-32	-34	-37	-40	-43	-46	-48	-51	-57	
4.5	-1	-7	-9	-12	-15	-18	-23	-26	-29	-32	-37	-40	-43	-46	-51	-54	-57	-59	-62	-68	-71	
6.7	-4	-9	-12	-18	-21	-23	-29	-32	-34	-40	-43	-46	-51	-54	-57	-62	-65	-68	-73	-76	-79	
8.9	-7	-12	-15	-18	-23	-26	-32	-34	-37	-43	-45	-51	-54	-59	-62	-65	-71	-73	-79	-82	-84	
11.2	-9	-12	-18	-21	-26	-29	-34	-37	-43	-46	-51	-54	-59	-62	-68	-71	-76	-79	-84	-87	-93	
13.4	-12	-15	-18	-23	-29	-32	-34	-40	-46	-48	-54	-57	-62	-65	-71	-73	-79	-87	-87	-90	-96	
15.6	-12	-15	-21	-23	-29	-34	-37	-40	-46	-51	-54	-59	-62	-68	-73	-76	-82	-90	-90	-93	-98	
17.9	-12	-18	-21	-26	-29	-34	-37	-43	-48	-51	-56	-59	-65	-71	-73	-79	-82	-90	-90	-96	-101	
WINDS ABOVE 18 M/SEC HAVE ADDITIONAL EFFECT																						
	LITTLE DANGER										INCREASING DANGER					GREAT DANGER						
	(FLESH MAY FREEZE WITHIN 1 MINUTE)										(FLESH MAY FREEZE WITHIN 30 SECS)											

FIGURE 86. Equivalent chill temperature

MIL-HDBK-759B

the vehicle was driving cross-country these temperatures ranged between 40°C and 54.5°C with an average outside air temperature of approximately 38°C. The moisture content of the air within a vehicle fighting compartment is increased by the evaporation of sweat from crew members. Assuming an average rate of evaporation of one liter (1 kilogram) per hour per person at temperatures up to 49°C, a crew of five would contribute 5 kg of water per hour, raising the relative humidity by a significant amount, posing a serious problem for body temperature regulation.

5.4.4.2 Vehicle and equipment operator enclosure and personnel compartment.

5.4.4.2.1 Heating. The heaters should be capable of maintaining a reference temperature of not less than 5°C at the minimum ambient design temperature with a vehicle moving at two-thirds maximum speed and the defrosters operating at maximum capacity. The reference temperature is measured 610 mm above the seat reference point of each operator/passenger position. Air temperatures around any part of the operator/passenger's body should not vary more than +/-5°C. The heater should achieve these criteria within one hour after it is turned on.

5.4.4.2.2 Ventilation. Outside fresh air should be supplied at a minimum rate of 0.57m³/min./person. Air flow rates for hot-climate operation (temperatures above 32°C) should be maintained between 4.2 and 5.7 m³/min/person, unless air conditioning (microclimate) cooling is provided. Air velocity at each person's head location should be adjustable either continuously or with not less than three settings (OFF, LOW and HIGH) from near zero to at least 120 m/minute.

5.4.4.3 Troop carrier vehicles. In vehicles used as troop carriers, the troop-carrying area should be heated as above.

5.4.4.4 Tanks. In cold-weather operations, experience has shown that crew heating is required for efficient tank operation. Owing to the great mass of steel involved in the design of most armored-vehicle fighting compartments, it is doubtful whether a heater of sufficient capacity can be installed for general heating of an entire fighting compartment. Local space heating at crew positions will normally be needed. To minimize power requirements for local space heating, it seems realistic to assume that the person will still require significant protective clothing. This also means that space should be allowed in the engineering design for the person with their protective clothing envelope. In addition, space heating can be minimized for the well-clothed persons by provision of auxiliary heat for the extremities, and providing power supply outlets for auxiliary heated protective clothing items at each crew station.

5.4.4.5 Surface temperatures. Measures should be taken to guard against inadvertent skin contact with surfaces of different temperatures. Surfaces that personnel touch (gearshift levers, steering wheels, dash controls, seats, side panels, and compartment walls) should have low heat conductivity. If personnel can touch metal surfaces that may get as hot as 49°C, special precautions are indicated such as shielding, insulating, relocating components, or adding warning decals, signs, or labels, Figure 87 shows the burn criteria for human skin. For temperatures at or below 0°C, pain and/or tissue damage (freezing) can occur.

MIL-HDBK-759B

5.4.5 Illumination.

5.4.5.1 General. Criteria for appropriate illumination must not be satisfied merely by providing a sufficient amount of light to perform tasks or providing emergency lighting (approximately 32 lux) to enable personnel to operate important controls or to find the exit from the system. The following should be considered.

- a. The brightness contrast between each visual task object and its background.
- b. Glare from work surfaces and light sources.
- c. The level of illumination required for the most difficult tasks.
- d. The color composition of the illumination source and the equipment surfaces.
- e. Time and accuracy required in task performance.
- f. Possible variations in operating conditions (such as outdoor panel blackout operation or outdoor panel visibility under bright sunlight) which may affect the lighting system, the task criteria, or the personnel.

5.4.5.2 Illumination levels and distribution. The examples of illumination levels expressed in Table 58 are presented so the designer may estimate the illumination criteria for those tasks within the system that are not directly related to the tasks of Table 59.

5.4.5.3 Illumination levels and vehicle fighting compartments.

5.4.5.3.1 General. For efficient performance of the various tasks which vehicle fighting compartment crews must perform, certain minimum amounts of light are required. To provide a basis for designing the interior lighting system of a vehicle fighting compartment, the tasks of each member of the crew should be carefully appraised to determine how much illumination they require. Among the duties of the crew, map reading undoubtedly requires the highest level of illumination while the location and identification of stowage items requires the lowest.

MIL-HDBK-759B

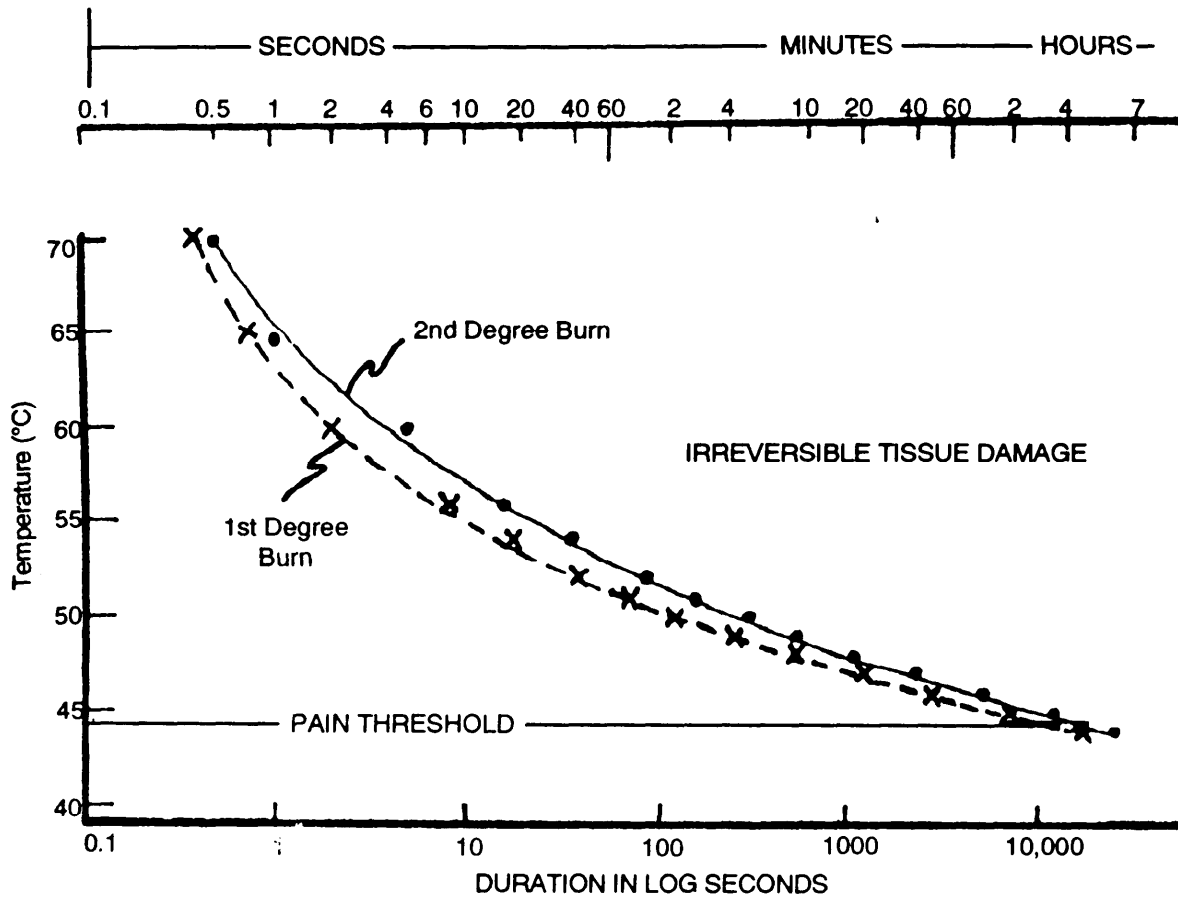

FIGURE 87. Burn criteria for human skin

5.4.5.3.2 Varied conditions. For a given task, the illumination required varies with conditions inside and outside the fighting compartment. In the daytime, for example, crew members are required to look through the periscopes or other visual devices to drive the vehicle, spot the enemy, and sight targets. They must also manipulate controls, load weapons, clear machine guns, read maps, and perform other tasks inside the fighting compartment. Thus, the crew members' eyes are exposed alternately to outside and inside light levels which, at times, may differ as much as a thousandfold. When this difference in intensity is great, glare results from exposure to the outside illumination and time is required for the eyes to become adjusted to the lower light levels inside the fighting compartment. During this adjustment, visual efficiency is greatly reduced, with a corresponding reduction in ability to perform the task at hand. Illumination of a higher order may be required for difficult tasks within the compartment. Where this requirement exists, auxiliary lighting should be provided for such difficult tasks as map and instrument panel reading.

MIL-HDBK-759B

TABLE 58. Illumination criteria for representative tasks

Task	<u>Illumination Levels in lux</u>		
	Recommended	Minimum	Light Source
Perceiving small details with low contrast for prolonged times or where speed and accuracy are essential (examples: repairing small components, inspecting dark materials, layout drafting).	1615	1075	General Services plus supplementary
Perceiving small details with fair contrast where speed and accuracy are not so essential (examples: handwriting, electronic assembly).	1075	540	General Services and/or supplementary
Prolonged reading, desk or bench work, general office and laboratory work (examples: assembly work, filing records).	755	540	General Services and/or supplementary
Occasional reading, recreation, reading signs where visual tasks are not prolonged (example: reading a bulletin board).	540	325	General Services and/or supplementary
Perceiving large objects with good contrast (example: locating objects in bulk supply warehouse).	215	110	General Services
Passing through walkways, handling large objects (example: loading from a platform).	215	110	General Services

5.4.5.3.3 Glare recovery. Figure 88 shows various fixed levels of outside illumination in combination with different intensities of interior illumination representative of the practical ranges of lighting obtainable in vehicle fighting compartments. The outside illumination levels were selected to cover the range of daylight up to an extreme of 108,000 lux, which represents the illumination produced by bright sunshine on snow at high latitudes or white sand near the equator.

MIL-HDBK-759B

TABLE 59. Specific-task illumination criteria

Work Area or Type of Task	Illumination Levels in Lux*	
	Recommended	Minimum
Assembly, missile component	1075	540
Assembly, general		
coarse	540	325
medium	810	540
fine	1075	810
precise	3230	2155
Bench work		
rough	540	325
medium	810	540
fine	1615	1075
extra fine	3230	2155
Business machine operation (calculator, digital, input, etc.)	1075	540
Console surface	540	325
Corridors	215	110
Circuit diagram	1075	540
Dials	540	325
Electrical equipment testing	540	325
Emergency lighting	--	32
Gages	540	325
Hallways	215	110
Inspection tasks, general		
rough	540	325
medium	1075	540
fine	2155	1075
extra fine	3230	2155
Machine operation, automatic	540	325
Meters	540	325
Missiles		
repair and servicing	1075	540
storage areas	215	110
general inspection	540	325
Office work, general	755	540
Ordinary seeing tasks	540	325
Panels		
front	540	325
rear	325	110
Passageways	215	110

*As measured at the task object or 760 mm above the floor

MIL-HDBK-759B

TABLE 59. Specific-task Illumination criteria - continued

Work Area or Type of Task	Illumination Levels in Lux*	
	Recommended	Minimum
Reading		
large print	325	110
newsprint	540	325
handwritten reports, in pencil	755	540
small type	755	540
prolonged reading	755	540
Recording	755	540
Repair work		
general	540	325
instrument	2155	1075
Scales	540	325
Screw fastening	540	325
Service areas, general	215	110
Storage		
inactive or dead	54	32
general warehouse	110	54
live, rough or bulk	110	54
live, medium	325	215
live, fine	540	325
Switchboards	540	325
Tanks, container	215	110
Testing		
rough	540	325
fine	1075	540
extra fine	2155	1075
	1055	540

*As measured at the task objector 760 mm above the floor.

NOTES:

1. Some unusual inspection tasks may require up to 10,800 lux of light.
2. As a guide in determining illumination criteria, the use of a steel scale with 0.38 mm divisions requires 1,950 lux of light for optimum visibility.
3. The brightness of transilluminated indicators should be compatible with the expected ambient illumination level and should be at least 10% greater than the surrounding brightness; however, the indicator brightness should not exceed 300% of the surrounding brightness.

MIL-HDBK-759B

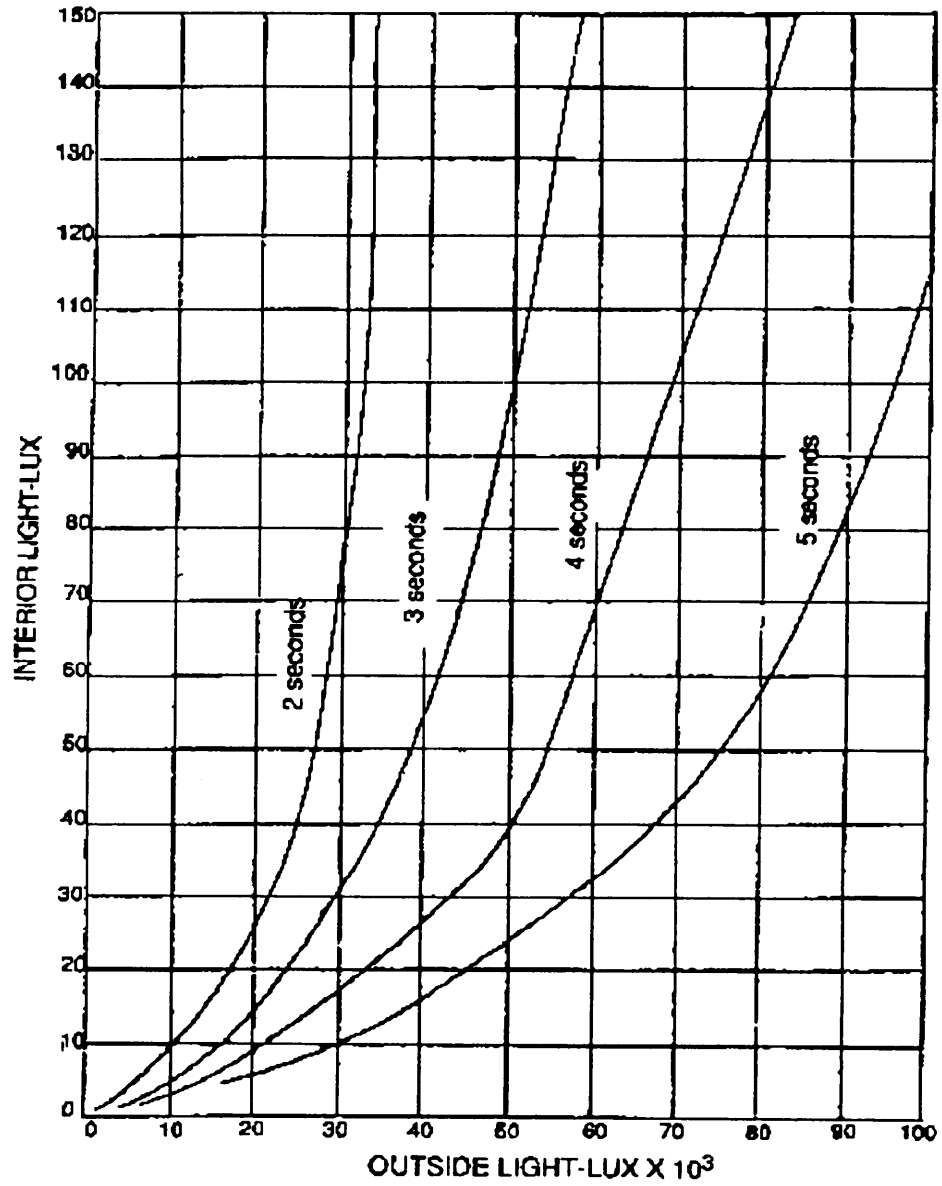

FIGURE 68. Glare recovery time curves for map reading after five minutes exposure to outside light

MIL-HDBK-759B

5.4.5.3.4 Interior lighting and detectability and dark adaptation. The illumination of outside objects is not controllable; the inside illumination of the vehicle fighting compartment is, and should be sufficiently bright to permit performance of all of the necessary duties within the fighting compartment, but dim enough so as not to interfere with dark adaptation during night operations. Minimum illumination is required, at night, for efficient performance of the necessary tasks since there are no disturbing outside light sources, and the eyes are adapted to low-level lights. Where maximum dark adaptation is required and detection by enemy image-intensifier night-vision devices is not a serious threat, red lighting should be used. To minimize detection and also retain a high degree of dark adaptation, a low density blue-green light (incandescent filament through a high-pass filter with a 600 millimicrons cutoff) should be used. This will reduce detection distances, compared to an equivalent intensity red light, by more than a factor of 10.

5.4.5.3.5 Dual light system. The illumination required for daylight operation (108 lux or less) in closed fighting compartments is considerably in excess of that necessary for night operations (11 lux or less), and red light offers no advantages under daylight conditions. The electrical energy required to produce red light of a given brightness is much more than that required for white light of equal brightness. Thus, a dual lighting system, supplying each crew position with white light for daylight operation and red light for night conditions, both controllable in intensity throughout the proper range, should be provided. Table 60 shows the minimum levels of illumination required for efficient performance of various tasks in fighting compartments.

TABLE 60. Levels of illumination for efficient performance of various tasks in vehicle fighting compartments

Task	Night Operation (Red or Blue-Green Light) (lux)	Daylight Operation (lux)
Map Reading	11.0	108.0
Clearing Machine Gun	4.3	43.0
Operation of Controls	3.2	43.0
Stowage	0.2	1.0

5.4.5.4 Lighting fixtures. Other factors which should be considered in selecting the number and location of fixtures are accessibility of lights, convenient operation of switches and other controls, and the absence of glare from the fixture itself or indirectly in the form of reflection from periscope windows or other reflecting surfaces.

MIL-HDBK-759B

5.4.5.5 Brightness ratios. The brightness ratios between lightest and darkest areas and/or between task and surroundings should meet the criteria presented in Table 61.

5.4.5.6 Glare.

5.4.5.6.1 General. One of the most serious illumination problems is glare or dazzle from surfaces. Relatively bright light shining into the observer's eyes as the observer tries to observe a relatively dim visual field or reflected glare from work surfaces is a common cause of reduced performance in visual tasks. Glare not only reduces visibility for objects in the field of view but causes visual discomfort.

TABLE 61. Brightness ratios

Comparison	<u>Environmental Classification*</u>		
	A	B	C
Between tasks and adjacent darker surroundings	3:1	3:1	5:1
Between tasks and adjacent lighter surroundings	1:3	1:3	1:5
Between tasks and more remote darker surfaces	10:1	20:1	**
Between tasks and more remote lighter surfaces	1:10	1:20	**
Between luminaries and adjacent surfaces	20:1	**	**
Between the immediate work area and the rest of the environment	40:1	**	**

*A - Interior areas where reflection off entire space can be controlled for optimum visual conditions.

B - Areas where reflection off immediate work area can be controlled, but there is only limited control over remote surroundings.

C - Areas (indoor and outdoor) where it is impractical to control reflection and difficult to alter environmental conditions.

**Brightness ratio control not practical

MIL-HDBK-759B

5.4.5.6.2 Direct glare. Direct glare arises from a light source within the visual work field. It should be controlled by avoiding bright light sources within 60° of the center of the visual field. Since most visual work is at or below the eye's horizontal position, placing luminaries high above the work area minimizes direct glare. Using indirect lighting and more relatively dim light sources, rather than a few very bright ones as well as using polarized light, shields, hoods, or visors to block the glare in confined areas will also reduce glare.

5.4.5.6.3 Reflected glare. Reflected glare refers to reflections from shiny surfaces in the visual field. It should be controlled by using surfaces that diffuse incident light, rather than reflecting it specularly and arranging direct-light sources so their angle of incidence to the visual work area is not the same as the operator's viewing angle.

5.4.5.6.4 Eyeglasses. These glare-control methods assume the operator is using unaided vision. Eyeglasses reflect glare into the eyes if a bright light behind the viewer is between 30° above and 45° below the line of sight, or if it is within 20° left or right of the line of sight.

5.4.5.7 Reflectance.

5.4.5.7.1 General. Large surface areas should be covered with non-saturated colors such as tints, pastels, and warm grays that are non-glossy. Some non-critical small areas such as door frames and molding may be glossy if ease of cleaning is essential.

5.4.5.7.2 Surface reflectance values. Generally recommended surface reflectance values for work places such as power stations, control rooms, offices and maintenance areas are indicated in Figure 89.

5.4.5.8 Dark adaptation.

5.4.5.8.1 General. Dark adaptation is the process by which the eyes become more sensitive in dim light. The eyes adapt almost completely in about 30 minutes, but the time required for dark adaptation depends on the color, duration of exposure and intensity of the previous light.

5.4.5.8.2 Ambient light. Ambient light is incompatible with dark adaptation. If it is dimmed enough so that it does not interfere with dark adaptation, it will not be bright enough by which to work. Where both ambient light and dark adaptation are required, the conflict should be resolved by evaluating the priorities of the operator's tasks. (If night vision is more important than reading maps, use red lighting.) Minimum interference with adaptation is produced by brief exposure of the lowest intensity possible. Colors often appear different under different types of illumination, so unless a display will always be used under ambient light, do not use color coding.

MIL-HDBK-759B

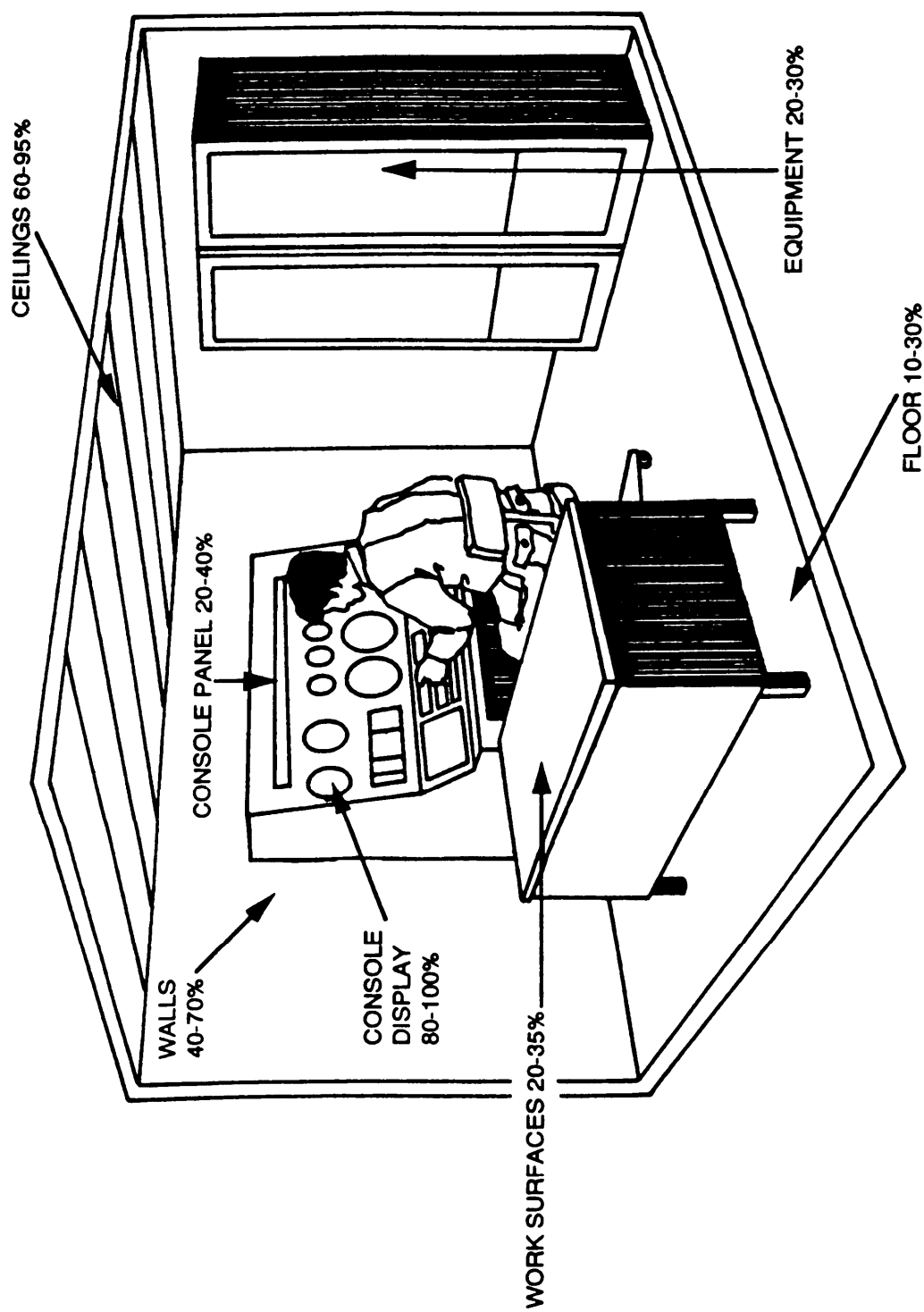

FIGURE 89. Workspace reflectance values

MIL-HDBK-759B

5.4.5.8.3 Red light. Low-brightness and red light is used to do visual work and for instrument and display markings (between 0.07 cd/m^2 and 0.35 cd/m^2) where maintaining maximum dark adaptation is required. This red light is obtained by passing white light through a filter that transmits only wavelengths longer than 620 millimicrons (red). A filter with a higher cutoff would maintain dark adaptation still more effectively, but it would waste too much of the available light energy.

5.4.5.8.4 Additional aids. The additional aids to night vision listed below should be incorporated.

- a. Lettering that must be read at low light intensities should be block-type white letters on a black background.
- b. All controls (knobs, switches) should be painted white.
- c. Instrument panels should be designed and located for both day and night use.
- d. Maps designed for use under red illumination should be used.

5.4.6 Acoustical noise.¹

5.4.6.1 General. Personnel should be provided an acoustical environment which will not cause personnel injury, interfere with voice or any other communications, cause fatigue, or in any other way degrade overall system effectiveness. The fact that a component which contributes to the overall noise may be government furnished equipment should not eliminate the requirement that the total system conform to the criteria herein.

5.4.6.2 Hazardous noise. Equipment should not generate noise in excess of maximum allowable level prescribed by MIL-A-8806, MIL-S-008806, MIL-STD-740, MIL-STD-1174, BUMEDINST 6260.6 or AFR 161-35, as applicable.

5.4.6.3 Non-hazardous noise. Workspace noise should be reduced to levels that permit necessary direct (person-to-person) and telephone communication and establish an acceptable acoustical work environment. Criteria for workspaces are defined by either the A-sound level (dB(A)) or the Preferred Speech Interference Level (PSIL) and are given in 5.4.6.3.1 through 5.4.6.3.5. The A-sound level is the desired requirement. Where it is not possible to meet the specified A-sound level, the corresponding PSIL requirement should be met.

5.4.6.3.1 General workspaces. Areas requiring occasional telephone use or occasional direct communication at distances up to 1.5 m should not exceed 75 dB(A) or 67 dB PSIL-4 or 68 dB PSIL (maintenance shops and shelters, garages, keypunch areas).

¹A detailed discussion of noise and blast may be found in US Army Human Engineering Laboratory TM 10-73.

MIL-HDBK-759B

5.4.5.8.3 Operational areas. Areas requiring frequent telephone use or frequent direct communication at distances up to 1.5 m should not exceed 65 dB(A), or 57 dB PSIL-4 or 58 dB PSIL (operation centers, mobile command and communication shelters, combat information centers, and word processing centers).

5.4.6.3.3 Large workspaces. Areas requiring no difficulty with telephone use or requiring occasional direct communication at distances up to 4.5 m should not exceed 55 dB(A) or 47 dB PSIL-4 or 48 dB PSIL (drafting rooms, shop offices, and laboratories).

5.4.6.3.4 Small office spaces/special areas. Areas requiring no difficulty with direct communication should not exceed 45 dB(A) or 37 dB PSIL-4 or 38 dB PSIL (conference rooms, libraries, offices, command and control centers).

5.4.6.3.5 Extreme quiet areas. Areas requiring extreme quiet should not exceed 35 dB(A) or 27 dB PSIL-4 or 28 dB PSIL (recording studios).

5.4.6.4 Facility design.

5.4.6.4.1 General provision. In the design of a workspace or facility, the ambient noise level should be controlled to the extent feasible through effective sound reduction or attenuation to meet the criteria herein.

5.4.6.4.2 Attenuation by materials and layout. Acoustic materials with high sound-absorption coefficients should be provided as necessary in the construction of floors, walls, and ceilings to effect the required sound control. In the physical design and layout of rooms and workstations, excessive noise should be attenuated by such means as staggered construction of walls, staggering of doors in corridors or between rooms, and use of thick-paned or double-paned windows.

5.4.7 Noxious substances.

5.4.7.1 General. Enclosed vehicle crew compartments are particularly susceptible to accumulations of noxious substances which result primarily from engine and heater exhaust and the firing of weapons from within the vehicle. From the practical standpoint of controlling health hazards, the critical contaminants are carbon monoxide, ammonia, nitrogen oxides, sulphur dioxide, and aldehydes (methane). In sufficient concentrations, the substances may incapacitate personnel or reduce substantially their performance through eye irritation, nausea, reduced mental alertness, and even unconsciousness. However, little is known relative to their interaction which is the primary reason given for the general tendency (in regulatory standards) to reduce allowable exposures for any one toxic element below its experimentally defined toxic influence level. Other contaminants may also create health hazards particularly when design changes are introduced or new fuels or propellants are used.

MIL-HDBK-759B

5.4.7.2 Carbon monoxide. Carbon monoxide (CO) is particularly dangerous in that it is odorless, colorless, and tasteless and is not ordinarily detectable by the human senses. Its effects are cumulative. Doses which may be tolerable by individuals for brief periods may prove to be dangerous to them when repeated often over several hours. CO combines with the blood to form carboxyhemoglobin (COHb). CO accumulates rapidly in the blood; however, the human body is extremely slow in reducing the COHb level in the blood, which may account for its toxic action. Ammonia is a pulmonary irritant and asphyxiant; nitrogen dioxide is both a pulmonary irritant and edemogenic agent.

5.4.7.3 Nitrogen oxides. Nitrogen oxides are also dangerous because they produce relatively little discomfort, yet even low concentrations can produce grave damage in the lower respiratory tract. Thus, exposed personnel may experience little irritation while breathing concentrations of nitrogen oxides which will, 12 to 24 hours later, prove fatal.

5.4.7.4 Concentrations. The presence of either carbon monoxide or ammonia in excessive concentration has been known to reduce the effectiveness of personnel and has even caused collapse and unconsciousness in battle. It is obvious that concentrations of such toxic agents should not be permitted to build up beyond tolerable limits in personnel compartments. The current occupational health standard as established by the Occupational Safety and Health Administration (OSHA) as a time-weighted average (TWA) for CO is 50 parts per million (PPM); for ammonia (NH₃) is 50 PPM; and for nitrogen dioxide (NO₂) is 5.0 PPM. The NO₂ is a ceiling value, which should not be exceeded at any time. Regulations governing personnel exposure to the noxious substances listed above are stated in terms of TWA and ceilings found in Title 29 Code of Federal Regulations (CFR), Labor, Part 1910, OSHA Standards, and also in the Federal Register for recently promulgated revisions. The American Conference of Governmental Industrial Hygienists (ACGIH) also publishes a list of TWA values and short term exposure limits (STEL) from which many of the OSHA standards are taken. ACGIH values are established with consideration to the latest in scientific information. OSHA values require congressional approval which may cause a delay in their implementation. In the interim, discrepancies arising between OSHA and ACGIH TWA values should generally be settled by taking the more stringent of values for purposes of safety. The current ACGIH TWA value for NH₃ is 25 PPM, as compared to the OSHA TWA for NH₃ of 50 PPM. The lower value should be used. The Surgeon General should be consulted in those cases where there is reason to believe that an alternate allowable exposure limit is appropriate.

5.4.7.5 Evaluation of carbon monoxide toxic hazard. Present procedure governing evaluation of the toxic hazard in enclosed fighting vehicles (tanks, personnel carriers) involves the determination of allowable exposure based upon a TWA of successive exposures over an 8-hour interval using the values (for all toxic elements) listed in the above noted CFR. Because it neglects to account for the CO actually inhaled by the exposed crew member, and it uses limit exposure values which may be inapplicable to the soldier population, that evaluative procedure is unrealistic. Some findings provide the assurance that non-smoking, healthy soldiers will not experience any significant effects on mental acuity or physical ability which are attributable to CO exposures providing COHb levels up to 10% nor is their health

MIL-HDBK-759B

impaired by such exposures. However, other experimental evidence suggests that visual acuity may degrade at or below COHb levels of approximately 5%. Because of both the uncertainties evident in the research findings and the critical nature of certain crew tasks involving visual perception (helicopter nap-of-the-earth flight and night flight operations), both systems design objective for all systems and the performance limit for aviation systems is specified to be a COHb level of not greater than 5% in MIL-STD-1472. The maximum acceptable CO exposure for personnel operating or maintaining equipment/systems other than aviation systems should be limited to values which will result in COHb blood levels not greater than 10%. The prediction of COHb blood content is determined by the following empirical equation:

$$\% \text{ COHb}_t = \% \text{ COHb}_o (e \exp (-t/A)) + 218 (1 - e \exp (-t/A)) \times \left(\frac{1 \text{ ppmCO}}{B + 1403} \right)$$

where % COHb_t is the predicted carboxyhemoglobin in the exposed individual; % COHb_o is the amount of COHb usually found in non-smoking adults; t is the exposure duration in minutes; and ppm CO is the carbon monoxide exposure in parts per million of contaminated atmosphere; A and B are constants which are obtained from Table 62 and depend on the estimated physical activity level of the individual during the exposure. This equation accounts for the minute respiratory volume of contaminated atmosphere actually inhaled by an exposed individual whose level of physical activity is either estimated or specified. For combat vehicle crewpersons, the specified work effort level scale required to be substituted in the equation is 4 for periods of weapons fire and 3 for intermediate periods. The equation also accounts for the elimination of CO by the body. It should be noted that the equation is applicable equally to short-duration high-level exposures as well as low-level exposures of long duration.

TABLE 62. Constants for substitution in empirical equation used to predict COHb blood content

Work Effort Scale	Work Effort Description	A Value	B Value
1	Sedentary	425	806
2		241	1421
3	Light Work	175	1958
4		134	2553
5	Heavy Work	109	3144

MIL-HDBK-759B

It should be emphasized that the exposure magnitude, frequency and duration is unlimited provided the criterion specified by MI L-STD-I 472 is met.

5.4.7.6 Weapon combustion products.

5.4.7.6.1 General. The gases produced when weapons are fired typically contain carbon monoxide (approximately one-third of the volume of fumes produced), oxides of nitrogen, and ammonia. Carbon monoxide concentrations can cause loss of mental alertness and even disorientation and collapse. Ammonia fumes are highly irritating and, even in small concentrations, produces eye watering.

5.4.7.7 Exhaust combustion products.

5.4.7.7.1 Composition. The composition of combat system exhaust gases varies with operating conditions. For example, concentrations of noxious substances are highest when starting and idling the engine in cold weather. In addition, exhaust composition depends on the loading conditions of the engine, the ambient temperature in which the engine is operating, and the type of fuel.

5.4.7.7.2 Exhaust products. The exhaust products of carbon monoxide and carbon dioxide occur no matter which fuel is used. In addition, when multi-fuel engines are using gasoline, the exhaust products include oxides of nitrogen, formaldehyde and acrolein. The exhaust products of engines operated on CITE, JP4, or kerosene, include aldehydes, water, hydrogen, and free carbon. When diesel fuel is used, the exhaust products include aldehydes, traces of nitrous oxides, sulphur compounds, oxygen, nitrogen, and methane. When multi-fuel engines are operated on CITE and diesel fuels, the exhaust products contain aldehydes which can cause eye irritation and nausea among personnel. Conjunctivitis and nausea resulting in temporary disability have occurred among personnel exposed to these exhaust products. These temporary disabilities are common in vehicles in convoy, transportation of troops, and other situations where personnel are subjected to the exhaust stream of multi-fuel engines. Table 63 shows some of the noxious exhaust products of engine fuels.

5.4.7.7.3 Ventilation. Careful consideration should be given in designing vehicle compartments to provide sufficient ventilation to maintain these products below an irritating and nauseating level, and the direction and dispersion of these products (the exhaust of multi-fuel engines) should minimize exhaust concentrations. For maximum allowable concentrations of gases, vapors, fumes, and dusts, refer to Title 29, Code of Federal Regulations, Labor, Part 1910, Occupational Safety and Health Administration Standards (see 5.4.4.2.2).

5.4.8 Protection against chemical warfare agents.

5.4.8.1 Basic protection. In the event of employment of chemical warfare (CW) agents by an enemy against forces, the first consideration should be the adequate protection of forces, and second, the maintenance of the ability to continue operations. There are basically three ways to provide protection against CW agents:

MIL-HDBK-759B

TABLE 63. Noxious exhaust products of engine fuels

Fuel	Exhaust Products			
	CO	CO ₂	N ₂ O ₄	SO ₂
CITE	x	x		
JP4	x	x		
Kerosene	x	x		
Diesel Fuel	x	x	x	x
Gasoline	x	x	x	x

- a. Individual protection, generally consisting of a protective mask, protective clothing, and perhaps a decontamination kit.
- b. Collective protection (operator or crew station), wherein each operator or crew member wears a protective mask connected to a centrally located gas particulate filter. The operator may or may not require protective clothing.
- c. Collective protection (overpressure), wherein the collective protection system provides an overpressure in the entire personnel occupied compartment. Protective masks and clothing are not required to be worn.

Selection of the best method to provide protection against CW agents should be based upon the operational considerations, cost effectiveness, and the requirements documentation.

5.4.8.1.1 General. For ground troops, required to be in the environment during the accomplishment of their duties, the protective ensemble is the only feasible way to accomplish the required protection. However, in other situations a choice can be made between crew or operator station collective protection and overpressure collective protection. For example, in a tank, the decision has always been to adopt the crew station collective protection on the premise that the weight, bulk, and power criteria for a central collective protection are prohibitive. On the other hand, a collective protection unit providing compartment overpressure has been developed for armored personnel carriers and certain vans and shelters. Additionally, shelters have been developed to provide a toxic-free environment for resting and meals.

5.4.8.2 Overpressure collective protection system. Whereas all three methods will protect personnel, the overpressure collective protection system has distinct advantages over the other two for interior environments. Primarily, the advantage lies in the fact that the overpressure system eliminates the requirement for masks and protective clothing. This eliminates the encumbrance of this equipment and any compatibility problem with equipment to be operated (keyboards, switchboards, telephone, and optical equipment). Additionally, there is no problem of mask hose interference, or reduction of mobility. The advantage of the overpressure system is that the danger of interior compartment contamination is minimized, therefore

MIL-HDBK-759B

minimizing the requirement to decontaminate the compartment and its contents. This aspect should not be considered lightly in view of the fact that (1) effective decontamination of electronic or optical equipment will be difficult if not impossible in the field, and (2) because of the intimate contact of the personnel with instruments and controls, as well as other interior surfaces of the compartment, contamination of the interior cannot be tolerated.

5.4.8.3 Protective ensemble. Wearing the protective ensemble (mask, hood, overgarment, and gloves) poses some serious problems in functional efficiency degradation. The overall ensemble imposes the problem of heat stress as body temperatures rise. This problem is directly related to the amount of exercise or physical activity of the wearer. Heat stress associated with the protective ensemble may be a particular problem in hot environments (see 5.4.2) where vehicle interiors may be expected to reach extreme levels. An associated problem is the loss of visual field and of visual acuity. This is particularly true if there is an operational requirement for use of optical equipment wherein mask-instrument compatibility may well pose a problem. Another associated problem is that of mask lens fogging with attendant loss of vision. The protective gloves reduce tactility, thus the ability to perform rapid, accurate finger tasks, particularly in restricted spaces such as keyboards or control panels. The effect of degradation effected by the bulk of the protective ensemble should be evaluated as a function of the operator's tasks; in some cases this may not necessarily be a major consideration.

5.4.8.4 Human factors in testing. Human factors engineers should assure that appropriate sub-tests are conducted throughout the development and operational testing of new materiel which will be required to be operated by troops in a CW environment. These tests should have as their objective the quantification and qualification of performance by the operator(s) under toxic-free versus toxic environments. The data thus generated will be useful in evaluating criteria for changes in design and task completion times. They will have the further advantage of providing data to the trainer in the preparation of programs of instruction for the users in operation and maintenance.

5.4.9 Radiation.

5.4.9.1 General. Radiation problems are becoming increasingly important as new uses for radioactive materials and methods for handling them are developed. Radiation is extremely dangerous and its health hazards are well known. Protective devices, permissible dosages and dosage rates change as new data accumulate; therefore, designers should contact the US Army Surgeon General for the latest available data.

5.4.9.2 Microwave radiation. Maximum exposure levels and methods for protecting personnel from hazards of microwave radiation are presented in TB MED 523.

MIL-HDBK-759B

5.4.9.3 Nuclear radiation. To find the maximum nuclear radiation to which personnel maybe exposed, designers should refer to Part 20, Title 10 Code of Federal Regulations and the US Army Surgeon General.

5.4.10 Dust.

5.4.10.1 Dust concentration. The dust concentrations to which armored personnel are exposed vary widely from imperceptible levels to dense clouds which may reduce visibility to almost zero. Table 64 provides a summary of the dust concentrations to which armored personnel are exposed.

5.4.10.2 Ventilation system. The ventilation system intake should be located in an area where concentration of dust is minimal when the vehicle is moving. Filters should be capable of removing dust particles above five microns in diameter. Dust skirts are of great value in reducing the dust raised around a vehicle and should be provided.

5.4.10.3 Personnel Protection. Dust causes temporary eye and throat irritation and at times degrades performance and interferes with operations. Goggles and throw-away respirators should be provided for use where needed.

5.4.11 Mud and water.

5.4.11.1 General. Mud and water are analogous to dust in that the same aspects of design affect them. As with dust, it may be impractical to eliminate them as problems affecting comfort, but vehicle design should minimize the problem.

5.4.12 Vibration.

5.4.12.1 Vibration effects onperformance. Performance is adversely affected to the degree that vibration can, at high levels, cause critical body damage. Vibration can also make dials, letters, and sight reticles difficult to read and makes controls, tools, or other objects difficult to manipulate. The human physical condition is affected by vibration because it contributes to increased fatigue, nervousness, and irritability that can lead to oversights and errors in judgments, and increases the difficulty of retaining head in sight eyecups, thereby allowing undesirable stray light to enter the eye.

5.4.12.2 Vibration limits.

5.4.12.2.1 Whole body. Facilities and facility equipment should be designed to control the transmission of whole body vibration to levels which will prevent safe operation and maintenance as shown in Figure 90 (see ISO DIS 2631). In the case of multi-directional vibration, each direction is to be evaluated independently with respect to the limits presented.

MIL-HDBK-759B

TABLE 64. Summary of dust concentrations to which armored personnel are exposed

Operations	Dust Concentrations Millions of Particles Per Cubic Meter
<u>Minimum Activity</u>	
Airborne dust from infantry camp; some from a road grader	320
Motor pool of a medical battalion; slow traffic	425
Bivouac area, Sunday afternoon, fresh breeze	545
Div. Surg. tent, Hq, camp area	740
Air base; planes taking off clean runway	765
Motor pool; ambulance driving in loose sand	795
Infantry training on regt. parade ground	885
Ordnance unloading depot. Only three vehicles moving	980
Army truck road. Dust raised by staff car	980
Regimental area of camp; normal traffic	1025
Gas dump; no vehicular movement. Light to no breeze	1030
Repeated passage of 1/4-ton truck on tank trail	1030
Railhead with light traffic; no convoy movements	1095
Railhead with little traffic	1130
Hq, camp; light traffic, fresh breeze	1140
Ordnance unloading depot; heavy wind storm, no traffic	1220
<u>Moderate Activity</u>	
Infantry column; four companies ahead of sampler	1450
In convoy behind half-track	1455
Asst driver's seat; light tank midway of column of tanks (co.)	1508
Evacuation hospital area; sandy surface, fresh breeze	1560
Corner tank battalion motor pool; 16 tanks and 1 truck moved	1720
Entrance to railhead; almost continuous truck traffic.	1800
Troops drilling--no traffic	1825
<u>High Activity</u>	
Maneuver road; dust raised by staff car	2650
Convoy of cargo trucks spaced 90 m	2790
From 1/4-ton truck and wind-blown dust	3670
Deliberate dust disturbance by 1/4-ton truck	3990
Convoy of trucks and towed 75mm guns	4626
Repeated passage of 1/4-ton through pulverized silt bed	5650
Alongside moving tank column	6600
inside tank following another 140 m	7730
Convoy of trucks passing by	8830
Following 1/4-ton truck	16670
Nine meters behind half-track; loose sand	26480

MIL-HDBK-759B

TABLE 64. Summary of dust concentrations to which armored personnel are exposed - continued

Operations		Dust Concentrations Millions of Particles Per Cubic Meter
<u>Extreme Activity</u> (conditions deliberately fixed for maximum dustiness)		
Medium tank operating alone on dry driving range, 16 km/h		12360
One tank trailing another, dry driving range, 16 km/h		24720
End of column of five tanks, 16-24 km/h		8830
Five tanks in wedge, sampled in a sixth center tank		15890
Midway of column of six light tanks, driving into wind		52970
Summary	Average	Range
Minimum activity	685	320 to 235
Moderate activity	1625	1450 to 1835
High activity	8155	2650 to 26480
Extreme activity	21890	12360 to 52970

5.4.12.2.2 Safety limits. In order to protect human health, whole body vibration should not exceed twice the acceleration values in Figure 90 for the time and frequencies indicated.

5.4.12.2.3 Proficiency levels. Where proficiency is required for operational and maintenance tasks, body vibration should not exceed the acceleration values shown on Figure 90 for the time and frequencies indicated.

5.4.12.2.4 Comfort level Where comfort is to be maintained, the acceleration values in Figure 90 should be divided by 3.15.

5.4.12.2.5 Motion Sickness. Very low-frequency vertical vibration should not exceed the limits given in Figure 91 in order to protect 90% of the unadapted males from vomiting in the exposure times indicated.

5.4.12.3 Equipment vibrations. Where both whole and part body vibrations are not a factor, equipment should be designed so that oscillations will not impair human performance with respect to control manipulations or the readability of numerals or letters. Such equipment should be designed to preclude vibrations in the shaded area of the upper curve in Figure 90.

5.4.12.4 Design for reduction and control. Vibration can be reduced and controlled by isolating equipment from vibration sources by shock mountings and fluid couplings, providing proper balance of rotating elements of equipment and providing damping materials or cushioned seats for standing or seated personnel.

MIL-HDBK-759B

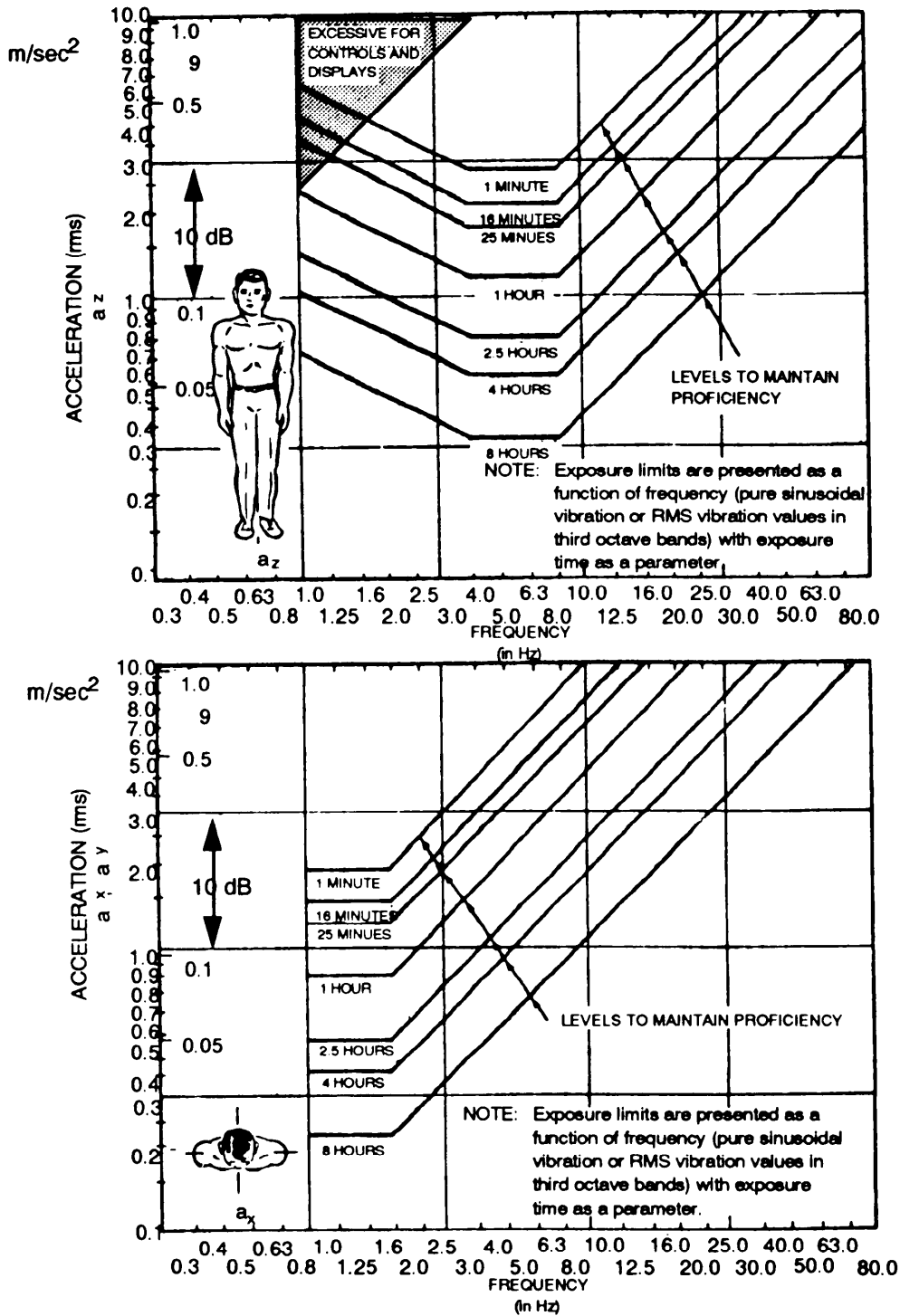

FIGURE 90. Vibration exposure criteria for longitudinal (upper curve) and transverse (lower curve) directions with respect to body axis

MIL-HDBK-759B

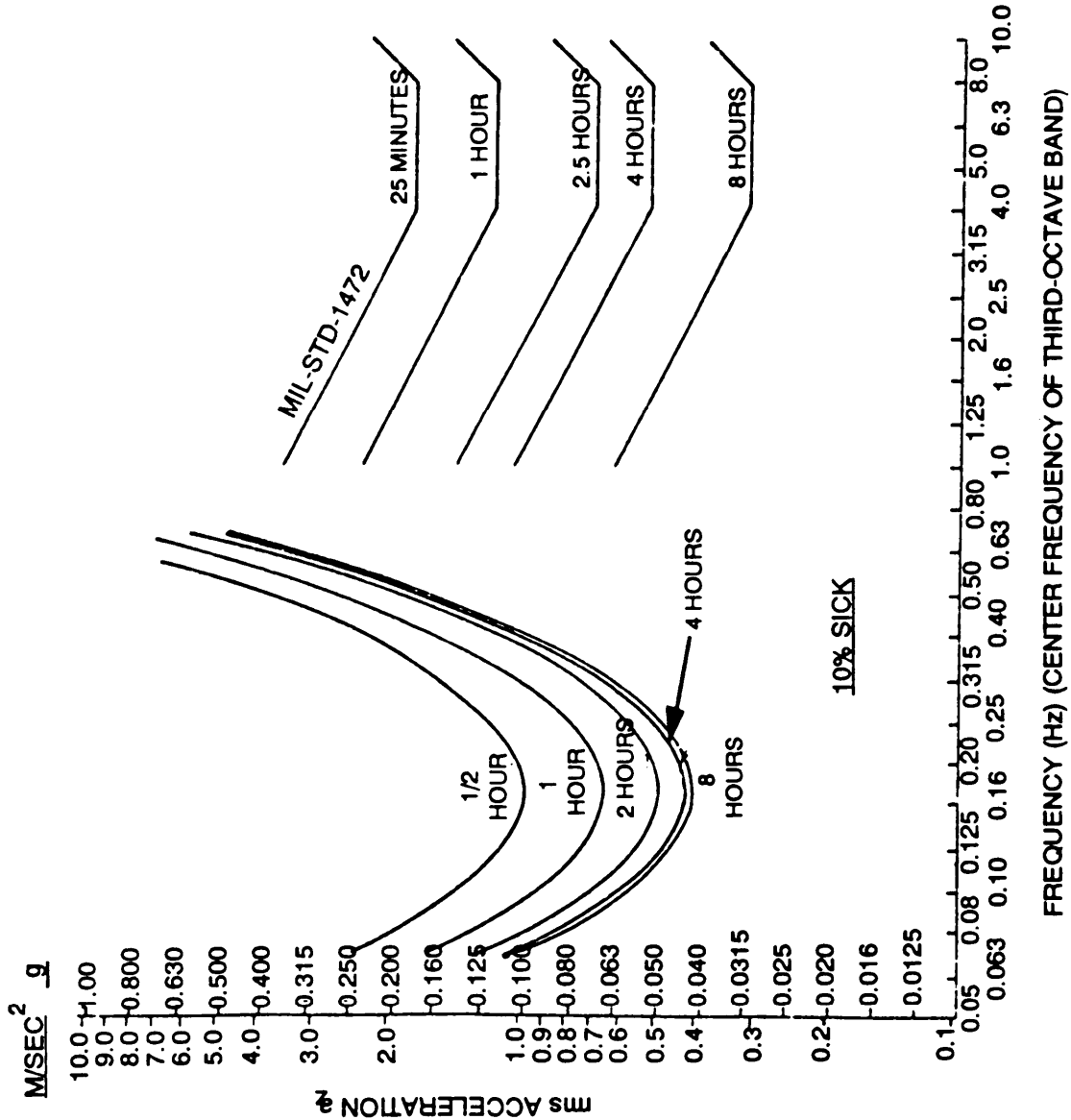

FIGURE 91. The 90% motion sickness protection limits for human exposure to very low-frequency vibration. [The MIL-STD-1472 (and ISO 2631) FDP vibration limits from 1 to 10 Hz are included.]

MIL-HDBK-759B

5.5 Labels, colors and markings.5.5.1 Labels, legends, placards, signs, and markings.5.5.1.1 General.

5.5.1.1.1 General criteria. Labels, legends, placards, signs and/or markings should be provided wherever it is necessary for an operator or technician to identify, interpret, follow procedures, or avoid hazards in the use of systems, equipment, or facilities except where the item and its use is obvious to the observer.

5.5.1.1.2 Basic characteristics. The characteristics of the label, legend, placard, sign, or marking should be determined by such factors as:

- a. the accuracy of identification required,
- b. the time available for recognition or other responses,
- c. the distance at which the device should be read,
- d. the illumination level and color characteristics of the illuminant, and
- e. the criticality of the label, legend, placard, sign, or marking to satisfactory and safe operator performance.

Labels should conform to these principles:

- a. A label should give the user the information needed to perform his task.
- b. Labels should be located consistently on all of the equipment.
- c. Labels should use familiar words; overly technical or difficult words should be avoided.
- d. Labels should be brief but unambiguous; punctuation should be omitted.
- e. Words should be printed so they read horizontally, not vertically.
- f. Labeling should be supplemented where necessary with other coding procedures (such as color and shape).
- g. Labels should be placed where they can be seen easily, not where other units in the assembly will cover or obscure them.
- h. Labels should be made large enough that the operators can read them easily at normal distance.
- i. Generally, capital letters should be used; however, if the label has several long lines, and lower-case letters should be used.

MIL-HDBK-759B

- j. Bold-faced letters should be used only for short words or phrases that require emphasis.
- k. Labels should be placed on, or very near, the item they identify; any confusion with other items and labels should be eliminated.
- 1. Labeling should be etched or embossed into the surface for durability, rather than stamped, stenciled, or printed. Decals are acceptable, but less desirable.

5.5.1.1.3 Prototype and Production systems. Labels, legends, placards, signs, and markings for both prototype and production systems should meet the criteria specified herein and meet the criteria specified for the duration of system use. Signs and markings should be designed so that they may be simply and easily affixed, altered, removed, or replaced since frequent design changes may be anticipated in prototype systems, labels, legends, and placards.

5.5.1.2 Orientation and location.

5.5.1.2.1 Orientation. Alphanumeric characters and symbols should appear "upright" to the observer so they are easily recognized and read in the normal left to right manner. Vertical arrangements of words for labels on signs should be used only when they are not critical for personnel safety or task performance, and where space is limited. When used, vertical labels should read from top to bottom.

5.5.1.2.2 Location. Labels, legends, placards, signs, and markings should be positioned so that they are visible from the nominal or expected observer's viewpoint reference when he needs to see them. Labels should be placed on or very near the items which they identify so as to eliminate confusion with other items and labels. Labels should be located so as not to obscure other information needed by the operator, and should be placed where a control or operator's normal hand or arm position will not obscure the label (see Figure 92).

5.5.1.2.3 Standardization. Labels, legends, placards, signs, and markings should be located in as consistent a manner as practical throughout a system, equipment, or facility.

MIL-HDBK-759B

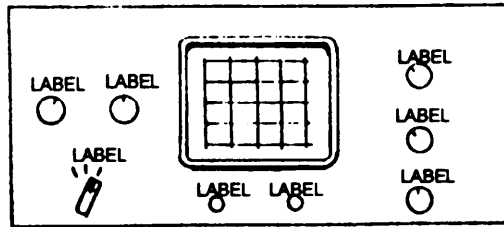

Locate labels consistently "above" or "below" a control or display on a given panel ("Above" is preferred except when the panel is located considerably above the observer's eye level).

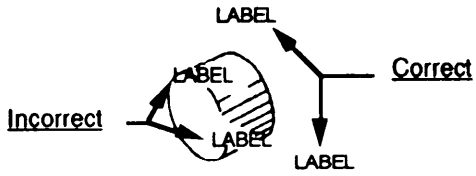

Locate label so that a control handle will not obscure the label.

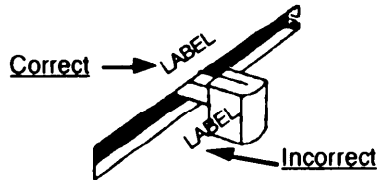

Do not place label on a control that could rotate the label to an upside-down position.

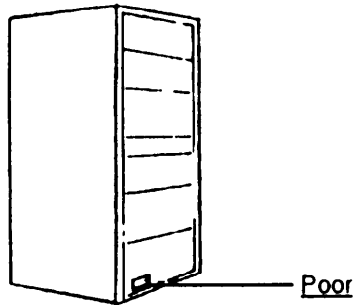

Do not place placards near the floor or other positions that preclude the observer from getting his or her eyes in a position adequate for reading the placard.

FIGURE 92. Location and position of labels

MIL-HDBK-759B

5.5.1.3 Content.

5.5.1.3.1 Equipment functions. Labels should primarily describe the functions of equipment items and in terms that the typical operator, technician or other observer understands. Engineering characteristics, nomenclature, or other terminology should be used only when a commonly-understood term is not available.

5.5.1.3.2 Abbreviations. Standard abbreviations should be selected in accordance with MIL-STD-12, MIL-STD-411, or MIL-STD-783 where appropriate. However, when the above references specify the same abbreviation for more than one function, such abbreviation should not be used for more than one function on the same equipment panel. If a new abbreviation is required, its meaning should be obvious to the intended observer.

5.5.1.3.3 Capital vs lower-case letters and punctuation. The following rules should be observed relative to use of capital and lower-case letters and punctuation marks:

- a. Labels should be printed in all-caps and periods should not be used after abbreviations.
- b. Legends should not be printed in all-caps and periods or commas should not be used.
- c. Placards (instructional material) may employ caps and lower-case letters when the amount of material consists of several lines. However, for short instructional material all-caps are preferred. An acceptable all-cap approach also may include use of larger caps for the initial letter in a paragraph or separate line of instruction or procedural step.
- d. Signs should consist of all-caps except in the case when the sign material is "instructional" and involves several lines of extended sentences, in which case capital and lower-case letters may be used.

5.5.1.3.4 Irrelevant information. Non-operational information such as trade names should not appear conspicuously on the face of instruments. If required, such markings should be subdued by small size, reduced contrast, and/or in an inconspicuous location so the operator's attention is not drawn away from critical instrument markings.

5.5.1.4 Qualities.

5.5.1.4.1 Brevity. As few words as necessary to convey the intended meaning should be used on labels, legends, placards and signs. Special markings and/or symbols should be considered when they will unambiguously convey meaning in a more direct manner than several words. Examples include pictorials and arrows.

MIL-HDBK-759B

5.5.1.4.2 Familiarity. Words and symbols should be chosen on the basis of user familiarity whenever possible provided the words or symbols express exactly what is intended. Engineering or other technical terms should be used only when such terms are familiar to the specific designated user. Common technical items or symbols do not have to be familiar to casual non-users. Common, meaningful symbols, such as % and +, may be used as necessary. Abstract symbols, such as Greek letters, should be used only when they have a commonly accepted meaning to all intended users.

5.5.1.4.3 Understandability. Extended instructional or procedural information for placards and signs should be concise, but understandable, to the intended user.

- a. Omit words that are unnecessary to convey the meaning of the message.
- b. When procedural steps are implied, place each procedural step on a separate line and include numbers, dots, or other techniques to emphasize the beginning of each step.
- c. Use acronyms sparingly and only when they are familiar to the intended user.
- d. Avoid use of instructions that require reference to another, perhaps unavailable resource. However, such reference may be used for placards that pertain only to a depot maintenance situation and where resource materials are typically available.

5.5.1.4.4 Visibility and legibility. Labels, legends, placards, signs, and markings should be designed to be read easily and accurately at anticipated operational reading distances, vibration motion environments, and illumination levels, taking into consideration the following factors:

- a. contrast between the lettering and its immediate background,
- b. height, width, stroke width, spacing and style of letters and numerals, and/or size of detail for other abstract or pictorial symbols,
- c. method of application (etching, engraving, decal, silk screen),
- d. relative legibility of alternate words, and
- e. specular reflection.

5.5.1.4.5 Consistence. When function and application are identical, words or abbreviations used should be identical. Conversely, the same words should not be used to identify two or more controls or displays when these are not functionally identical.

5.5.1.4.6 Label background. Label background colors should contrast visually with equipment background as specified in MIL-STD-1 473. No special additional background for the label should be used on the equipment without approval of the acquiring activity. Placards or signs that include their own independent

MIL-HDBK-759B

background should provide maximum contrast between lettering and immediate background. Shiny metallic backgrounds should not be used for operational labels, placards, signs, or markings.

5.5.1.4.7 Label life. Characters, markings, and symbols on labels, legends, placards, and signs should remain sharp, have high contrast, and be mounted so as to minimize the degrading effects of wear or become obscured by grease, grime, or dirt.

5.5.1.4.8 Access. Labels should be placed on the outside of equipment covers to identify control, display, or other functions located within a covered compartment. Labels attached to lines or cables for the purpose of identification should be positioned so the label is visible and properly oriented with respect to the nominal viewing position of the field technician rather than the factory assembler. Both ends of a cable or line should be labeled, and the connector elements also should contain appropriate, matching labels.

5.5.1.4.9 Label surface. Whenever practicable, labels, legends, placards or signs should be placed on a flat surface. If a label must be placed on a curved surface, lettering or symbols should be completely visible to the observer from his nominal vantage point. When the curvature of the surface is such that the lettering becomes too small to be read, another mode of labeling, such as an attached tag, should be used.

5.5.1.5 Design of letters, numerals and symbols.

5.5.1.5.1 Letter/numeral design.

5.5.1.5.1.1 Type style. Letters and numerals should be of a simple style without serifs except as may be necessary to distinguish between characters which would otherwise be confused. Acceptable styles are shown in Table 65. Capital letters should be used for labels, legends, and short messages. Lower-case letters should be used on placards and signs with long messages that include complete text sentences.

5.5.1.5.1.2 Letter/numeral width. The width-to-height ratio should be between 3:5 and 1:1 for all characters and styles except for the "l" and "1". (The 1:1 ratio is appropriate for use on curved surfaces such as counter drums, small pipes, and cables.)

MIL-HDBK-759B

TABLE 65. Close equivalent type faces suitable for labeling

Type Font	Equivalent Type Font
Airport Bold Condensed	Futura Demi-Bold
Airport Demi-Bold	Futura Medium
Airport Medium Condensed	Futura Bold
Airport Semi-Bold	Groton Condensed
Alternate Gothic #2	Lining Gothic #66
Alternate Gothic #3	Spartan Heavy
Alternate Gothic #51	Spartan Medium
Alternate Gothic #77	Tempo Bold
Franklin Gothic Condensed	Vogue Medium

5.5.1.5.1.3 Character stroke width. When characters are used on a light background, the stroke width should be approximately 1/6 the height of the character. When light characters are used on a dark background, the stroke width should be 1/7 to 1/8 the height of the character. These ratios should apply regardless of how high characters are made for distance viewing. However, for certain applications, characters with different stroke widths may be used on the same sign for emphasis. In this case, the thinnest character stroke should be no less than 1/8 nor the thickest character stroke greater than 1/5 of the respective character heights.

5.5.1.5.1.4 Stroke continuity. Continuous stroke characters should be used where applicable and practical for all equipment labels, legends, placards, and signs. Stencil characters may be used for shipping containers. Stencil characters should not have stroke breaks greater than 1/2 the character stroke width. Stencil stroke widths should conform to criteria in 5.5.1.5.1.3.

5.5.1.5.2 Character spacing. The minimum space between characters within a word should be one stroke width. However, character spacing should be adjusted to provide an appearance of "open area balance" within single words. An example is adjacent vertical strokes between adjoining characters compared to adjacent characters in which vertical components are far apart. In such cases it is recommended that the space between adjacent vertical strokes be slightly wider than between vertical/horizontal or horizontal/horizontal strokes.

5.5.1.5.3 Word spacing. The preferred space between words is the width of one character (except for "l" or "1"). Minimum spacing between words should be 1/2 the width of one character.

5.5.1.5.4 Confusion between "l", "1" and "L" and between "0" and "O". When a label, legend, placard, or sign contains characters which might be confused, they should be made distinguishably different.

MIL-HDBK-759B

- a. The lower case letter 'L' should have a tab at the lower end extending to the right.
- b. The numeral '1' should have a tab at the upper end extending to the left.
- c. The numeral '0' should appear narrower than the letter 'O' of a given font.

5.5.1.5.5 Line spacing. The minimum space between lines should be 1/2 character height.

5.5.1.5.6 Character height. Character height for labels, legends, and signs should be determined on the basis of criteria in Figures 93 and 94.

5.5.1.5.7 Pictorials. Pictorial symbols may be used in place of word labels and/or in addition to a word label when the pictorial provides quicker operator response. They should be completely unambiguous in the expected visual operating environments and should not be used on a control that may rotate and thus position the symbol so that it may be confusing. Pictorials for automotive equipment should conform to criteria in Federal Motor Vehicle Safety Standard (FMVSS-101). Other pictorials should be subject to approval by the acquiring activity.

5.5.1.5.8 Borders. There should be sufficient clear space between characters and words used for labeling or signing to prevent the label from appearing crowded or difficult to read. The minimum clearance around a character or word should be 1/2 character height or more. Clearance around a character, or word, or set of words should not make the label appear "lost" within a large expanse of background. No performance limits have been established for maximum clearance around a label.

5.5.1.6 Equipment labeling.

5.5.1.6.1 Assemblies, components, and parts. Each assembly, component, and part should be labeled with obvious exceptions (carrying handles, panel fasteners, equipment locks, door handles, vehicle steering wheel, aircraft joystick). All labels should conform to criteria herein with regard to visibility, readability, and meaningfulness.

MIL-HDBK-759B

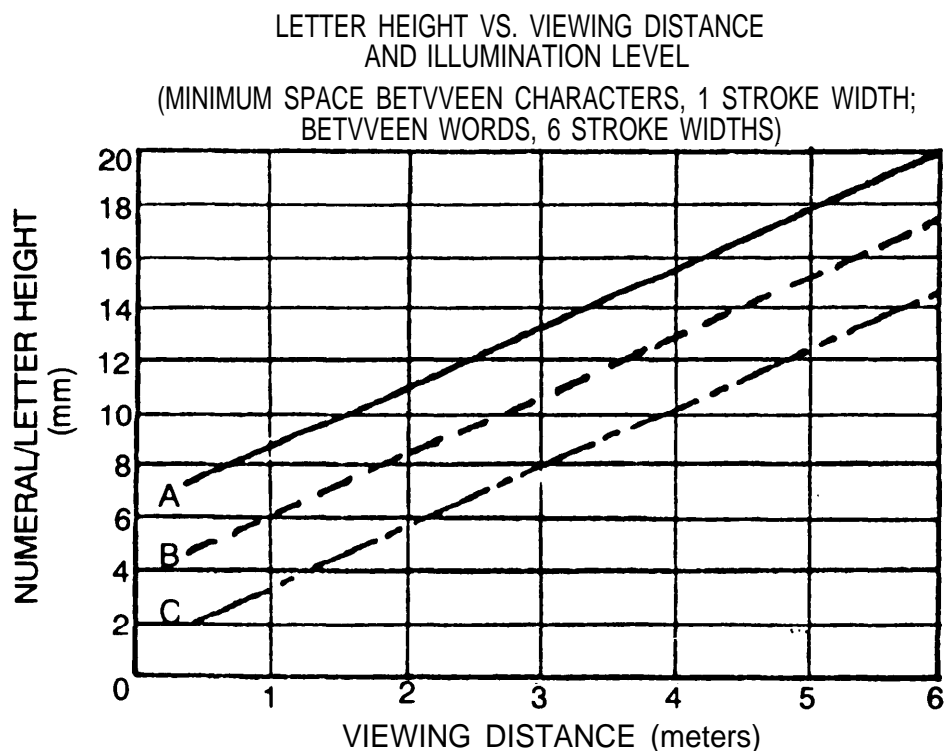

- A. For instruments where the position of the numerals may vary and the illumination is between 1.0 and 3.4 cd/m^2 .
- B. For instruments where the position of the numerals is fixed and the illumination is 1.0-3.4 cd/m^2 , or where position of the numerals may vary and the illumination exceeds 3.4 cd/m^2 .
- C. For instruments where the position of the numerals is fixed and the illumination is above 3.4 cd/m^2 .

NOTE: For marking of Aircrew Station Displays refer to MIL-M-18012.

FIGURE 93. Character height criteria for instruments, panels, and equipment viewed in close proximity

MIL-HDBK-759B

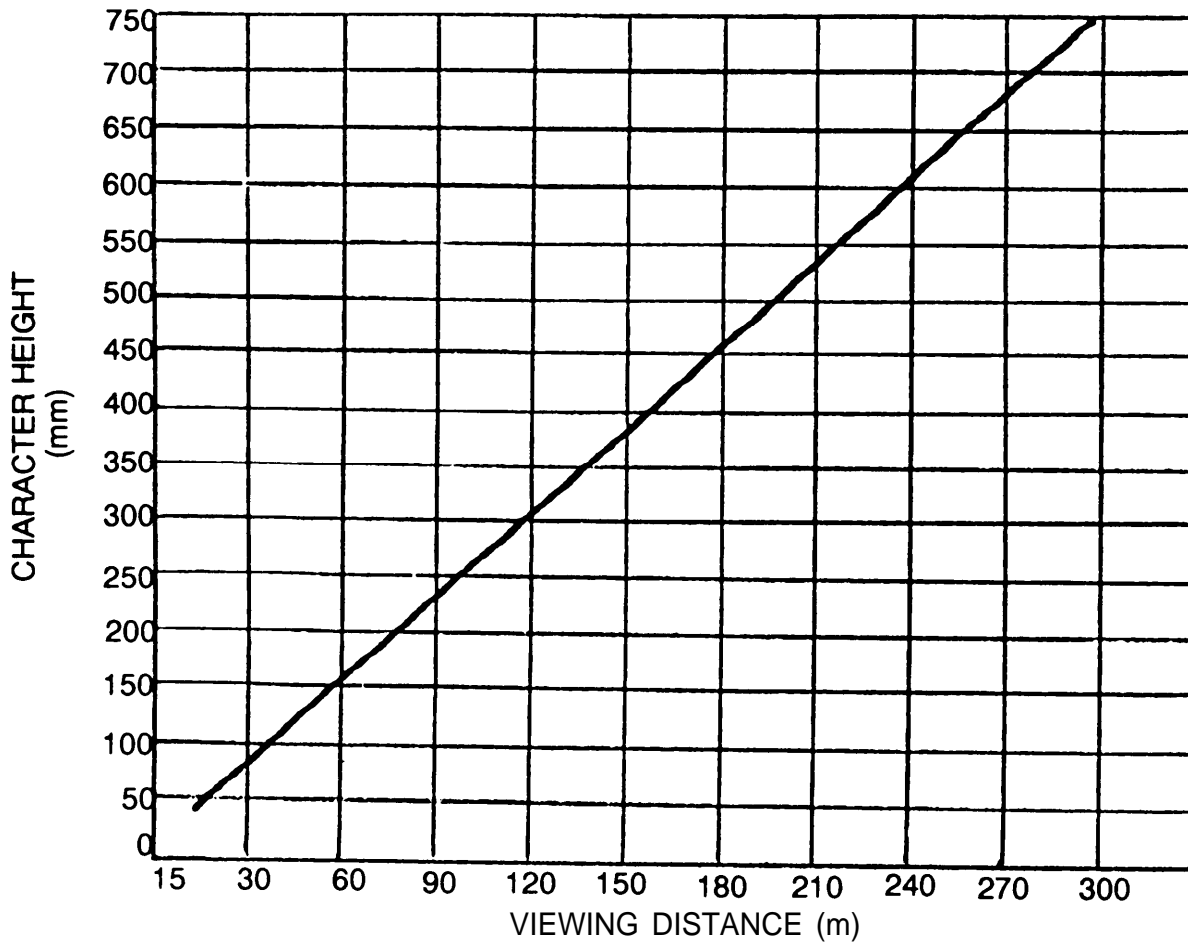

Minimum letter height for 3 meter viewing distance = 7.6 mm. Letter height for longer viewing distances may be computed as follows:

$$\text{Desired letter height (mm)} = \frac{\text{Viewing distance (m)} \times (7.6) \text{ mm}}{3\text{m}}$$

FIGURE 94. Character height criteria for viewing signs at extended distances

MIL-HDBK-759B

5.5.1.6.2 Cabinets. When several equipment cabinets are located in a single work area, each cabinet should be labeled to aid the operators and other personnel in quickly identifying what is located in each equipment cabinet. Such identification labels should be located in a conspicuous position considering the typical observation points from which each piece of equipment must be identifiable. Primary cabinet labels should be located in as consistent a manner as practicable so that observers do not have to hunt for the label. The size of the material on each label should be consistent with viewing distance criteria.

5.5.1.6.3 Panels. Where applicable, each panel within a given equipment or console should be labeled if the panel must be identified from others. When a given panel integrates a specific operating function as distinct from another panel, a general system or subsystem identification label should be provided.

5.5.1.6.4 Subfunctions. When subfunction areas on a single panel must be easily and quickly differentiated from other areas on the panel, the subfunction area should have a label approximately centered above the subfunction area. When the shape of the components within the subfunction area is not uniform, consideration should be given to surrounding the area with a suitable border to define the limits of the subfunction area.

5.5.1.6.5 Cabinet, panel, subfunction, and component label differentiation. Labels for identifying a prime equipment cabinet vs panels, subfunctions on a panel, and individual panel components should be capable of being differentiated in terms of the label size (letter height). The size encoding should progress according to the priority listing indicated below:

- a. Largest label size for the prime equipment.
- b. Next largest label for individual panels.
- c. Next largest label for subfunction areas within a panel.
- d. Smallest label for individual components, such as displays or controls.

Note: Label sizes should be compatible with expected viewing distances; however, to provide discriminable differences among label sizes, each label character height should be at least 25% less than, or greater than, the next function label (see Figure 95).

5.5.1.7 Control/display labeling.

5.5.1.7.1 General criteria. Controls and displays should be appropriately and clearly labeled with the basic information needed for proper identification, utilization, actuation, or manipulation of the element. Integrally illuminated panels should comply with MIL-P-7788.

MIL-HDBK-759B

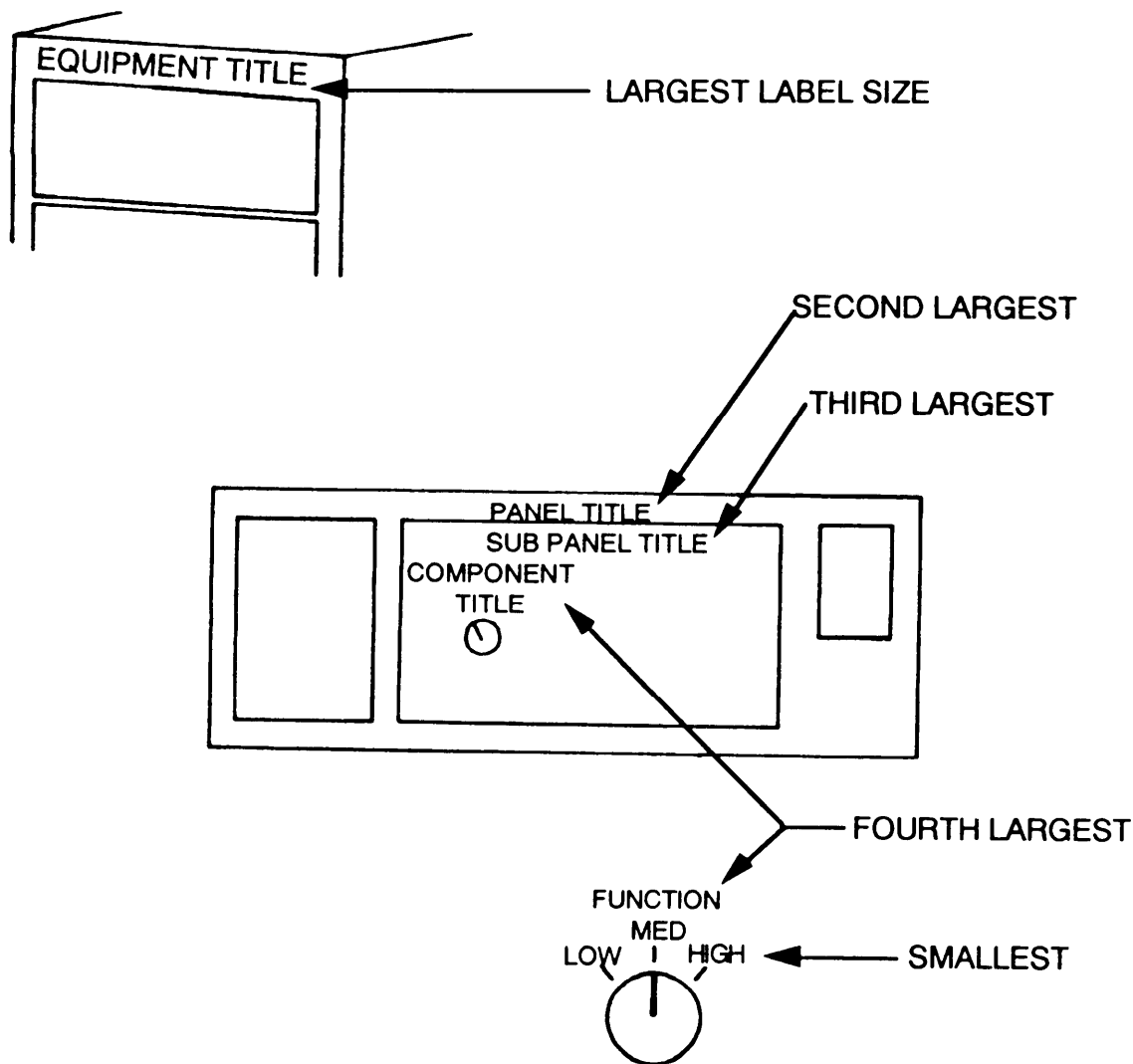

FIGURE 95. Label size-hierarchy example for equipment, panel, subpanel, and component identification

MIL-HDBK-759B

5.5.1.7.2 Simplicity. Displays and controls should be labeled in the simplest and most direct manner possible. Abbreviations may be used when they are familiar to operators (mm, g/cm²).

5.5.1.7.3 Functional labeling. Each control and display should be labeled according to its function and the following criteria should apply:

- a. Highly similar names for different controls and displays should be avoided.
- b. Instruments should be labeled in terms of what is being measured or controlled, taking into account the user and purpose.
- c. Control labeling should indicate the functional result of control movement and may include calibration data where applicable. Such information should be visible during normal operation of the control.
- d. When controls and displays must be used together (in certain adjustment tasks), appropriate labels should indicate their functional relationship.

5.5.1.7.4 Location. The following should apply to the location of control and display labels.

- a. Ease of control operation should be given priority over visibility of control position labels.
- b. Labels may be located either on the control or display and/or on the panel adjacent and above the control or display as appropriate. However, consideration should be given to an alternate label position relative to the control if the control and/or the operator's hand will obscure the label. If the display or control is above the operator's eye level it may be more appropriate to locate a particular label below the display or control (see 5.5.1.2.2 and 5.5.1.2.3).
- c. The units of measurement (volts, pascals, meters) associated with a display should be located on the face of the display, but on a control, they should be on the panel adjacent to the control.
- d. Labels should be used to identify functionally grouped controls and displays. The labels should be located above the functional groups they identify. When a line is used to enclose a functional group and define its boundaries, the label should be centered at the top of the group either in a break in the line or just below the line. When colored pads are used, the label should be centered at the top within the pad area.
- e. Locations should be labeled throughout a system and within panel groupings as uniform as practical.

5.5.1.7.5 Size graduation. Size graduation should be used when a control has both an identifying label and sub-labels and/or numerical graduations (see 5.5.1.6.5).

MIL-HDBK-759B

5.5.1.8 Labeling for identification.

5.5.1.8.1 Assemblies. Label assemblies with clearly visible, readable, and meaningful names or signs. Assembly labels should:

- a. specify the overall system of which the assembly is a part,
- b. include the assembly's popular name and function, and
- c. include a stock number for requisition purposes.

The gross identifying label on an assembly should be located:

- a. where adjacent assemblies will not obscure it,
- b. on the flattest, most uncluttered surface available,
- c. on a main chassis of the assembly, and
- d. where it will not be removed accidentally, obstructed, or damaged in handling.

5.5.1.8.2 Instruction date. Instruction-plate decal specifications can be found in MIL-P-514. Instructions should be as brief as clarity allows and placed where the operator can see them easily. They should read from left to right and listed in a step-by-step format rather than in a continuous paragraph.

5.5.1.8.2.1 Diagrams. Diagrams, containing only the information the operator needs, should be used where possible. Orient such diagrams so they relate logically to the objects to which they pertain. Locate them in conspicuous places on or near controls.

5.5.1.8.2.2 Color. Instructions should be printed in white letters on a black background. The black color should be 37038, FED-STD-595, or an approved equivalent.

5.5.1.8.2.3 Lettering. Information-plate lettering should be 12-to 14-point-size, with titles in 24-point letters.

5.5.1.8.2.4 Caution plate/decals. Caution plates or decals should be printed in yellow letters on a black background in conformance with AR 385-30. The black color should be 37038, FED-STD-595; the yellow color should be 23538 or 23655, FED-STD-595.

5.5.1.8.3 Lift points. Mark lift and hoist points clearly indicating weight and stress limitations. Label lift or hoist joints at the point of lift, not on removable parts of the body member that may be separated from the lift point.

MIL-HDBK-759B

5.5.1.8.4 Safety and hazards. Wherever possible, equipment should be designed so it does not present hazards to personnel or equipment. If hazards are unavoidable, warning signs should be displayed prominently. These safety labels should be brief and uncluttered and generally be no more than two or three words.

5.5.1.8.5 Hazard signing and marking. Appropriate signing and marking of all potential hazards to personnel should be provided. The following signing and marking should be considered.

- a. Fixed physical obstructions (low overheads, open hatches or manholes, posts, and guardrails).
- b. Moving hazards (conveyor belts, chains, gears, loaders, cranes, and booms).
- c. Equipment contact hazards (high-voltage and high-temperature).
- d. Radiation hazards (electromagnetic and nuclear).
- e. Laser beams.
- f. Toxic contaminants (substances and gases).
- g. Flash or high intensity light.
- h. Requirement for safety glasses.
- i. High noise or blast.
- j. Criteria for hard hats.
- k. Explosives.
- l. High-pressure containers and hoses.
- m. Slipping and falling hazards.
- n. Other (fire, first aid and rescue).

5.5.2 Colors and marking.

5.5.2.1 Painting and marking. Equipment should be painted and marked in accordance with MI L-STD-I 473.

MIL-HDBK-759B

5.5.2.2 Colors. Where neither current regulations nor the acquiring activity specify colors, the following colors selected from FED-STD-595 should be used:

Interiors and Equipment

Ceiling	27875	White
Door, Inside		Lusterless Forest Green
Floors	36118	Gray
Lettering	37038	Black
Panels	26492	Gray
Walls	24533	Green

Exterior Equipment

Covers		Lusterless Forest Green
Handles		Lusterless Forest Green
Lettering	37038	Black or
	37875	White (on Lusterless Forest Green Surfaces)
Panels		Lusterless Forest Green

5.6. Maintenance.5.6.1 Maintainability.

5.6.1.1 General. The Army program for materiel readiness emphasizes the complementary attributes of reliability and maintainability. Reliability is best expressed as the probability the materiel will perform its intended function, for example, remain ready without requiring unplanned maintenance. Maintainability is the ease of keeping the materiel in, or restoring it to, readiness and availability. Maintainability depends on accessibility of parts, internal and external configuration, use, and repair environment, as well as the time, tools and training skills required for maintenance. The objectives of improving maintainability are to make materiel more available to perform its function and mission and to reduce the cost of operational support during the materiel's service life. Army materiel designers should contact the Maintenance Directorate of the Commodity Command responsible for procurement to receive guidance and the latest available data about the Army Maintenance Program.

5.6.1.2 Maintainability in the desire schedule. To avoid costly maintenance, or redesign, maintainability should be designed into the materiel during the initial development stage. Therefore, it is imperative to schedule for maintainability. First plan, then design, and finally, test the design to ensure maintainability.

5.6.1.2.1 Planning for maintainability. In planning for maintainability, designers should consider the points listed below.

- a. Determine the size of required access openings, work surfaces, and workspace so that components are accessible to maintenance personnel.

MIL-HDBK-759B

- b. Study operational materiel similar to that to be designed. List the maintenance features built into it and, from its maintenance history and experience, identify additional maintenance features that should have been incorporated to improve maintainability.
- c. Determine how components should be arranged and located to provide rapid access to those components with the lower reliability that will probably require maintenance most frequently, or whose failure would critically degrade the end item's performance.
- d. Identify tools and test equipment already in the operational system that can be made available for maintenance of the materiel being designed.
- e. Determine what type, number, and organization of manuals the maintenance personnel will need to maintain the materiel properly, effectively, and safely.

5.6.1.2.2 **Designing for maintainability.** Wherever practical, the designers should consider and incorporate the following features into design/development projects.

- a. Simplification of operator and maintenance functions.
- b. Use of modular or unit packaging or throw-away components and techniques.
- c. Use of self-lubricating principles.
- d. Use of sealed and lubricated components and assemblies.
- e. Use of built-in testing and calibration features for major components.
- f. Use of self-adjusting mechanisms.
- g. Use of gear-driven accessories to eliminate belts and pulleys.
- h. Minimize number and complexity of maintenance tasks.
- i. Maximize design simplicity.
- j. Design for quick recognition of malfunctions or marginal performance.
- k. Design for quick identification of the replaceable defective components, assemblies, and parts.
- l. Design to eliminate torque specifications at organizational/aviation unit maintenance (AVUM) level and minimize need for all other torque specifications.
- m. Design to minimize skills and training requirements of maintenance personnel.

MIL-HDBK-759B

- n. Design to minimize the types and number of tools and test equipment (both standard and special) required to perform maintenance.
- o. Design for accessibility to all systems, equipment, and components requiring maintenance, inspection, removal, and replacement.
- p. Design for maximum safety and protection for personnel and equipment.
- q. Design equipment to permit maintenance from above and outside in contrast to requiring access for maintenance from underneath.
- r. Design of items should facilitate manual handling required during maintenance and comply with established manual force criteria.
- s. Design equipment to facilitate assembly and disassembly.

5.6.1.2.3 Testing the design. Development and production models should be tested for maintainability with representative Army personnel under operational conditions. These tests should use maintenance personnel with the same amount of training as those assigned to actual maintenance, and use the procedures, tools, test equipment, and manuals that maintenance personnel will use.

5.6.1.3 Manuals. Complete and current maintenance manuals should be issued with the materiel as it is released for use.

5.6.2 Stowage.

5.6.2.1 General. The following statements are applicable to stowing equipment.

- a. Stowed items should be secured by straps, brackets or other restraining devices to provide for cross-country operation.
- b. All stowage locations should be designed to drain adequately when the vehicle is on level ground. Drain holes should be arranged so that they will not be blocked by normal stowage.
- c. Items which are flammable or subject to damage by leakage of lubricants, fuels, or water should be stowed in a manner to protect them from engines, generators, and exhaust components.
- d. To prevent its loss, peculiar equipment should be designed to be properly secured when installed or stowed.
- e. Items of mission-critical nature should be stowed in a manner to permit rapid access by crew members.
- f. Consider all environments in which the crew will operate when locating and designing stowage space for items worn by crew members.

MIL-HDBK-759B

5.6.2.2 Identification. A stowage plan should be provided identifying the stowed items and their locations. Also, stowed items should be permanently labeled for ease of identification.

5.6.2.3 Interference. Stowed items should not interfere with system functions, operations, or established personnel movement (entrance, exit, or escape) routes.

5.6.2.3.1 Removal and replacement. Stowed items should be capable of being removed and replaced without having to remove or replace other stowed items or components of the system.

5.6.2.4 Retaining devices. Items should be capable of being stowed and removed under all environmental conditions. The retaining devices should be simple, capable of quick removal and replacement, and need no tools. Retaining devices should be attached to either the stowage space or the stowed item to prevent loss.

5.6.2.5 Utilization of stowage space. The accessibility and locations of stowed equipment should be determined by the functional utilization of each item. Items used by a particular crew member should be stowed in a convenient, accessible location within the functional area of the crew member's station.

5.6.2.5.1 Unused space. Unused space should be utilized to provide suitable stowage for items.

5.6.2.5.2 Individual items. When operating equipment, stowage should be available for doffed personal items such as individual weapons, small arms ammunition, rations, and helmets if donning of other special gear is required.

5.6.2.5.3 Stowage areas/boxes - doors and covers.

- a. Unless access covers or doors are intended to be removable, they should be designed so they can be retained open.
- b. Instructions about contents in a box should be located so they can be read when the door is open.
- c. Required access should be provided to the rear of sliding, rotating or hinged units so they open or rotate their full distance freely and remain "open" by themselves.
- d. Openings of covers or doors should be designed to be obvious or have opening instructions affixed to the outside.
- e. When a cover or door is in place, but not secured, it should be visually obvious.
- f. Sharp edges and corners on doors, covers, and other exposed surfaces should be rounded.

MIL-HDBK-759B

- g. To simplify reinstalling removable inspection access doors, they should be interchangeable or of the size and shape which will make their proper position obvious.
- h. Obstructions (on equipment material (OEM) or structural members) should never block covers or doors so they cannot be opened or removed, or restrict the required access through the cover or door opening.
- i. If covers are hinged, space equal to the sweep volume of the cover should be allowed so the body frame and brackets will not obstruct its opening.
- j. Items should be capable of being stowed and unstowed by the 5th through 95th percentile user while wearing cold-weather gear and gloves without having to assume a strenuous or difficult position.

5.6.3 Effects of climate on maintenance personnel.

5.6.3.1 General. Successful maintainability design should consider the effect of the working environment on human performance. Consideration should be given to adverse as well as normal environmental factors of temperature, humidity, illumination, and dust, which could affect the ability of personnel to perform as required.

5.6.3.2 Temperature extremes. Although the effects of temperature on human performance are not completely quantified, it is known that certain temperature extremes are detrimental to work efficiency. As the temperature increases above the comfort zone, mental processes slow down, motor responses are slower, and the likelihood of error increases. As the temperature decreases below the comfort zone, physical fatigue and stiffening of the extremities begin.

5.6.3.3 Heat. Heat is probably the most important factor in reducing the operational efficiency of personnel. The design recommendations listed below should be considered.

- a. Where possible, provide air conditioning if temperatures exceed 29.5°C. In any event, adequate ventilation should be provided in equipment trailers or other locations where personnel are performing monitoring, servicing, or other maintenance tasks.
- b. When maintenance technicians must work for periods of time inside equipment which is exposed to the sun, air conditioning should be provided in the enclosure or a large volume of air in compliance with established ventilation criteria should be provided.

MIL-HDBK-759B

- c. Where feasible, appropriate heat reflector and absorbent surfaces on equipment which must be maintained should be employed while personnel and equipment are exposed to the sun.
- d. Where frequent maintenance, such as checking or adjusting a component, is impossible or delayed because of excessively high temperatures, the equipment should be redesigned so the component is in a cooler area. If this is impossible, provision should be made to cool the component to permit the required maintenance.

5.6.3.4 Cold and windchill.

5.6.3.4.1 Cold. Maintenance personnel on duty in cold regions are physically and psychologically disadvantaged. It has been found that personal discomfort increases rapidly as the temperature drops below -12°C . Performance of organizational maintenance is expected without shelter in the field down to -29°C or equivalent windchill (see FM 31-71, Northern Operations). Maintenance in cold regions is unique. Those measures that are normally within the capabilities of the trained operator of equipment in temperate zones necessarily revert to the maintenance person located at the organizational or aviation unit maintenance (AVUM) level in the polar zone. Also, a considerable number of the tasks that a maintenance person would normally perform revert to direct support or aviation intermediate maintenance (AVIM) unless adequate shelter is provided. Without shelter and heat, most adjustments are impossible. With cold-weather mittens or anti-contact gloves, even the simple task of removing or inserting screws becomes extremely difficult.

5.6.3.4.1.1 Temperature effect on performance. When workers are properly dressed, they can perform down to between 0°C and -18°C for 30 minutes without interference from the cold (see Figure 96). The figure also indicates that the decrement in performance, below temperatures of -18°C , rapidly increases as the temperature

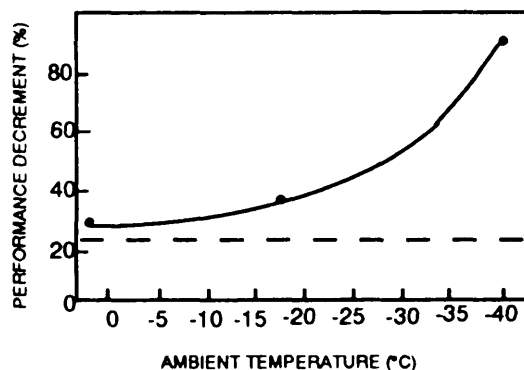

FIGURE 96. Change in performance decrement at different ambient temperatures

MIL-HDBK-759B

5.6.3 .4.1.2 Design features. The following features should also be considered by the designer.

- a. Maintenance should be able to be performed without shelter at the organizational level when the temperature is as low as -29°C or an equivalent windchill factor exists.
- b. In cold environments heated working areas for maintenance personnel above the organizational level should be provided. For organizational maintenance activities, the equipment should be designed (use quick-disconnect servicing equipment) to require a minimum sustained working time. Procedures should be clear and specific.
- c. Equipment should be dried if it is to be returned to out-of-door arctic temperatures after shop maintenance. Moisture which has condensed on such equipment will cause it to freeze with possible resultant damage and subsequent increased maintenance.
- d. The following should be considered in design of maintenance accessibility for winterized equipment.
 - (1) Winterization equipment, such as preheater, should be positioned where they do not interfere with accessibility to perform maintenance tasks.
 - (2) In locating access doors and panels, consider the effects of rain, snow, and ice formation.
 - (3) Where feasible, workspace access openings should be provided to accommodate personnel wearing cold-weather clothing.
 - (4) Drains should be provided that can be adequately accessed by personnel wearing cold-weather clothing to drain liquids to prevent freeze damage.
- e. In areas where technicians may suffer freezing if bare hands are used when maintaining equipment such as liquid oxygen lines, sufficient access and internal workspace should be provided to permit them to wear the appropriate protective gloves.

5.6.3.4.2 Windchill. No general index, such as effective temperature, is available for expressing all of the factors involved in cold exposure, but the Windchill Index is a scale commonly used to express the severity of cold environments. This index is an empirical expression of the total cooling power of the environment, and although it is not based on human cooling, it has become a practical guide to the severity of temperature-wind combinations. A windchill chart is shown in Figure 85. It is a usable guide to the severity of exposure conditions for personnel who are appropriately dressed and not wearing heated garments.

MIL-HDBK-759B

5.6.4 Tools.

5.6.4.1 General. Determining tool design independent upon maintenance operations and characteristics of the equipment. Neglecting tool design until equipment design and procedures are final may result in the need for special tools or an unnecessarily wide variety of standard tools.

5.6.4.1.1 Tool design during equipment design. Definition of tool requirements early in equipment design and development, before procedures and designs are final, will result in tools compatible with the equipment on which they will be used and with the job to be performed. Tools should be designed for simplicity, practicality, and universality and should be evaluated for adequacy during developmental testing of the system.

5.6.4.1.2 Special tools. The requirement for special tools should be minimized or eliminated. This requirement should be considered mandatory on the part of the design engineer. Consideration of tool design early in equipment development will result in fewer special tools and devices. Special tools should be used only when standard tools cannot be used or when necessary to facilitate maintenance tasks, reduce time, or improve accuracy. Special tools already in the supply system should be investigated for adequacy in unique situations. Necessary special tools should be made available when the equipment requiring their use is completed.

5.6.4.2 Other design and maintenance considerations. These areas should be considered in design and distribution of tools.

- a. If possible, require only those tools normally found in the maintenance technician's tool kit.
- b. Minimize the variety and number of sizes of tools required.
- c. A comprehensive list of tools needed for all maintenance tasks should accompany each equipment system. This should include all special tools necessary to perform the authorized work, together with the equipment items requiring their use.
- d. Equipment should be designed to minimize the need for torque wrenches. The design activity should review each special requirement in an attempt to make design changes to eliminate the need for torque wrenches.
- e. If torque wrenches or guns are used for factory assembly and are necessary equipment, provide maintenance personnel with similar tools.
- f. Specify tools which are compatible with the design of the equipment on which they will be used as well as with the job to be performed.
- g. Provide for the use of speed or power tools such as ratchets, speed screwdrivers, or power wrenches when demanded by torque requirements or space limitations.

MIL-HDBK-759B

- h. Enable the technician to assemble a tool for many different uses by providing maintenance personnel with socket wrenches and accessories (breaker bars, extensions, and joints).
- i. Positive snap-locking action should be used for connecting sockets to the various components of a socket set. They should be designed so they can be easily connected and disconnected.
- j. Tool handles should have adequate gripping surfaces. Tools used where dropping could result in maintenance delay or possible tool loss should be provided with thongs sufficiently long to enable the user to place a loop over his wrist.
- k. The use of heat- or cold-resistant handles on tools which are to be used in extreme climates should be specified. Metal handles are undesirable for use in cold climates.
- l. In evaluating the finish to be applied to tools, the designer should consider that tools with a dull finish prevent reflected glare in areas of high illumination. However, dull-finished tools are often overlooked when closing assemblies, causing loss of tools and possible damage to the equipment. The designer should therefore consider the advantages and disadvantages of the type of finish in relation to the potential application of the tool.

5.6.4.3 Safety features.

- a. Adequate insulation should be provided on tool handles or other parts of the tools which the technician is likely to touch while performing maintenance on electrical or electronic equipment near voltages in excess of 30 volts.
- b. Spark resistant tools should be provided if they are to be used in areas where fire or explosion hazards exist.
- c. Storage for tools should be provided so they cannot fall and cause personnel injury or equipment damage.
- d. Sharp corners and edges should be eliminated on tool chests.
- e. Casters or a sufficient number of properly sized and located handles should be provided to facilitate lifting if tool chests are too large to be handled easily by one person. Handle location should ensure that the chest will remain balanced when lifted.

5.6.5 Accessibility/maintainability.

MIL-HDBK-759B

5.6.5.1 General. Accessibility is defined as the relative ease with which an assembly component can be reached for inspection, service, repair, or replacement. It is a fundamental requirement for maintainability and should be designed into the equipment because adding access provisions for maintenance purposes after the equipment is built is inefficient, costly, and often inadequate. If it can be reached quickly, requiring the use of only a few simple steps, an item is accessible; if it requires many tools, special tools, many or difficult operations, it is inaccessible, even though it is possible to eventually reach it. The disassembly or removal of parts that are in the way of easy access to a part needing maintenance is highly undesirable, especially in field conditions. Adequate space is usually not available for laying out parts as they are removed. This increases the possibility that they will be lost, damaged, or contaminated, and further malfunctions will be introduced into the system.

5.6.5.2 Psychological aspects. The more difficult or involved a maintenance task is the more readily an operator or mechanic will put it off in preference to less demanding tasks. Periodic maintenance activities, such as checks, adjustments, or general troubleshooting may be unduly postponed or neglected entirely. Thus, inaccessibility is a human factors engineering problem as well as a problem for the design engineer.

5.6.5.3 “Whole body” access. Another aspect of accessibility often overlooked is the “whole body” accessibility feature involved in a particular maintenance operation. It is not enough to provide a suitable access opening to a component for the insertion of a tool, a light or a hand. Consideration should also be given to the position of the maintenance person with respect to the equipment while performing the particular maintenance task. Can they perform the task while standing on the ground; are footholds and handholds needed on the sides of the vehicle; is an awkward body position required? If an awkward body position cannot be avoided, the person should be able to exert the force necessary to accomplish the maintenance task from the awkward position.

5.6.5.4 Visual access. Does the person have visual access as well as access for their hands or tools? The designer should determine whether it is necessary for the technicians to see what they are doing. If this is a requirement, it may be necessary to make the access large enough to accommodate hands, arms, and tools, and still leave an adequate view or an auxiliary viewing area.

5.6.5.5 Environment. The environment in which maintenance tasks will be performed should also be considered by the designer when determining the size of access openings. Access for a gloved or mittened hand is considerably larger than for a bare hand. Wearing gloves or mittens seriously limits the dexterity and skill with which technicians can perform their duties. Certain simple tasks may be impossible to perform while wearing arctic mittens. Wearing cold-weather clothing creates problems such as persons becoming less agile. Their bodies may become wedged in narrow hatches, or their feet may stumble on steps, ladders, and small, closely-spaced pedals. Their hands may be unable to operate intricate hand controls with deftness and precision. Anthropometric data for nude personnel can be found in Tables 28-47, and for arctic clad personnel in Table 48.

MIL-HDBK-759B

5.6.6 Workspace criteria.

5.6.6.1 General. The system criteria should be based on the following minimum considerations for the 5th to 95th percentile maintenance population wearing cold-weather clothing listed below.

- a. Points where operation and maintenance may be required.
- b. Space, clearance, access and movement criteria needed for personnel using equipment to perform the functions of operation and maintenance.
- c. Criteria for access or passage to the workstation, as well as the size and weight of equipment carried and used at the workstation.

5.6.6.2 Other features. The workspace should allow personnel to change their body positions if the task requires kneeling, crawling, or crouching for a prolonged period of time. Consideration should also be given to providing protection against any potential hazards which might exist while personnel are performing their tasks. Auxiliary hooks, holders, lights, outlets, non-skid treads, expanded metal flooring, or abrasive coating on surfaces used for walking, climbing, or footholds should be provided at the workstation to assist personnel in performing their jobs, as appropriate. Top surfaces of equipment should be reinforced and provided with non-skid surfaces whenever they are used as work platforms. (Use 113.6 kg per person to calculate anticipated load.)

5.6.7 General-access criteria.

5.6.7.1 Design. Where possible and feasible, design for accessibility by using modular design, and equipping major units and assemblies (particularly engines and turbines) with removable housings so they can be inspected completely. Any replaceable item should be designed so that it can be removed after opening only one access (unless the accesses are latched or hinged doors). Accesses should be designed so that they are located, covered, and fastened so it will not be necessary to remove components or wires to reach an item requiring maintenance. These openings should be directly in line with the equipment to be serviced or maintained.

5.6.7.2 Visual inspection. Items requiring visual inspection (hydraulic reservoirs, gauges) should be located so personnel can see them without removing panels or other components, particularly if hazards can be encountered inside the equipment.

5.6.7.3 Sharp edges. Accesses having sharp edges or protrusions that could injure personnel or damage hoses should be lined with internal fillets or other suitable protection prior to access for maintenance.

MIL-HDBK-759B

5.6.8 Access.

5.6.8.1 General. Access should be provided to all points, items, units, and components which require testing, servicing, adjusting, removing, replacing, and repairing. The type, size, shape, and location of accesses (see Table 66 and Figures 97 through 99) should be based on a thorough understanding of the considerations listed below.

- a. Operational location, setting, and environment of the unit.
- b. Frequency of use.
- c. Maintenance tasks performed through the access and the intricacy of the tasks.
- d. Time required to perform maintenance functions.
- e. Types of tools and accessories required.
- f. Workspace required.
- g. Type of clothing likely to be worn by personnel.
- h. Necessary access reach.
- i. Visual requirements and the intricacy of the tasks.
- j. Packaging of items and elements behind the access.
- k. Mounting of items, units, and elements behind the access.
- l. Hazards in using the access.
- m. Size, shape, weight, and clearance requirements for logical combinations of human appendages, tools, and units that will enter the access.

MIL-HDBK-759B

TABLE 66. One-hand access openings

A. Arm to elbow		
Light clothing:	100 mm x 115 mm or 115 mm dia.	
Cold-weather clothing:	180 mm sq. or dia.	
B. Arm to shoulder		
Light clothing:	125 mm sq. or dia.	
Cold-weather clothing:	220 mm sq. or dia.	
<u>Minimal finger-access (first joint)</u>		
C. Push button access:		
	Bare hand:	30 mm dia.
	Gloved hand:	40 mm dia.
D. Two fingers, twisting:		
	Bare hand:	50 mm dia.
	Gloved hand:	65 mm dia.

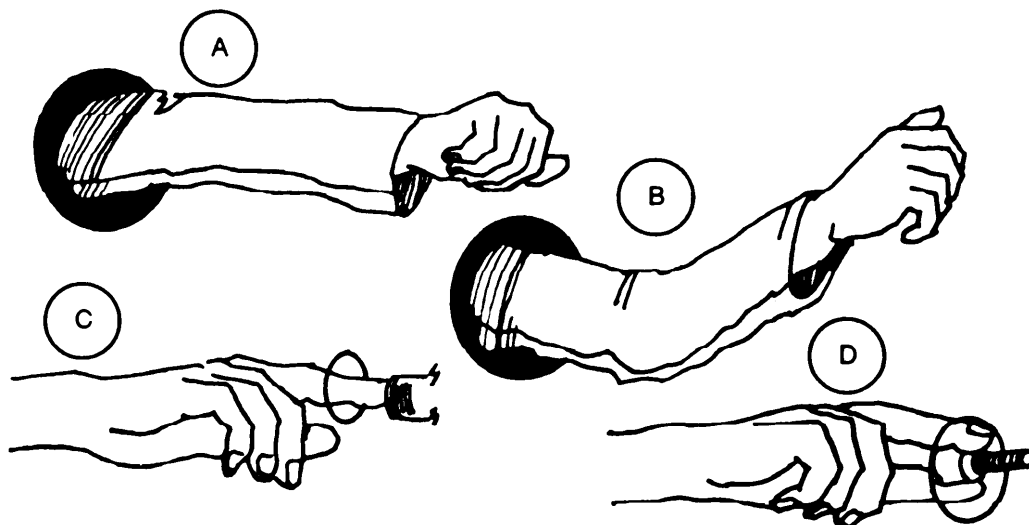
**FIGURE 97. One-hand access openings**

MIL-HDBK-759B

OPENING DIMENSIONS	DIMENSIONS (IN MM)		TASK
	A	B	
	110	120	USING COMMON SCREWDRIVER, WITH FREEDOM TO TURN HAND THROUGH 180°.
	130	115	USING PLIERS AND SIMILAR TOOLS.
	135	155	USING "T" HANDLE WRENCH, WITH FREEDOM TO TURN HAND THROUGH 180°
	270	200	USING OPEN-END WRENCH, WITH FREEDOM TO TURN WRENCH THROUGH 60°.
	120	155	USING ALLEN-TYPE WRENCH WITH FREEDOM TO TURN WRENCH THROUGH 60°.
	90	90	USING TEST PROBE.

FIGURE 98. Access opening dimensions

MIL-HDBK-759B

OPENING DIMENSIONS	DIMENSIONS (IN MM)		TASK
	A	B	
	110	120	GRASPING SMALL OBJECTS (UP TO 50mm WIDE) WITH ONE HAND.
	W+45	125*	GRASPING LARGE OBJECTS (50mm OR MORE WIDE) WITH ONE HAND.
	W+75	125*	GRASPING LARGE OBJECTS WITH TWO HANDS, WITH HANDS EXTENDED THROUGH OPENINGS UP TO FINGERS.
	W+150	125*	GRASPING LARGE OBJECTS WITH TWO HANDS, WITH ARMS EXTENDED THROUGH OPENINGS UP TO WRISTS.
	W+150	125*	GRASPING LARGE OBJECTS WITH TWO HANDS, WITH ARMS EXTENDED THROUGH OPENINGS UP TO ELBOWS.

* Or sufficient to clear part if part is larger than 125 mm.

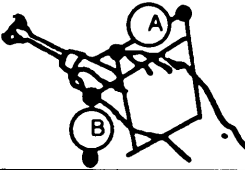
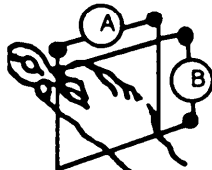
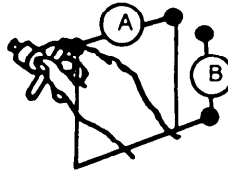
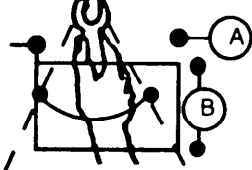
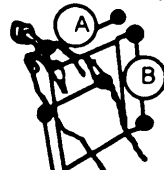
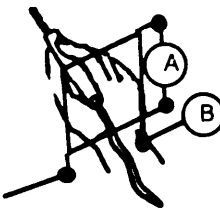
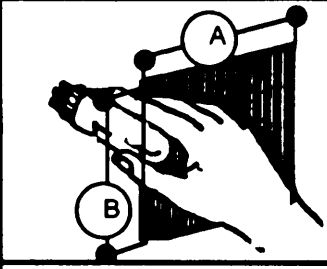
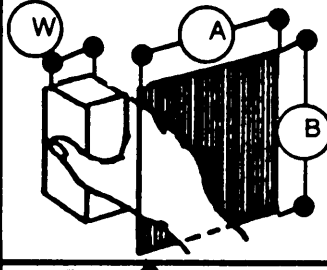
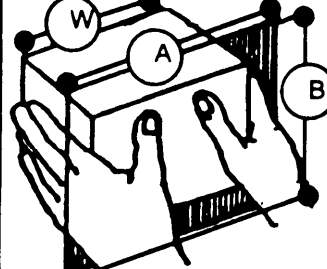
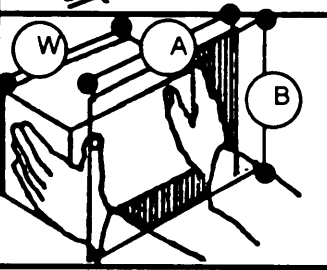
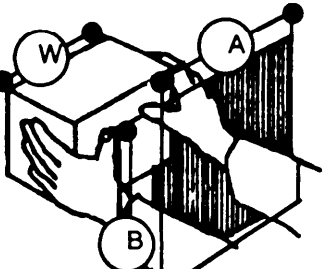
FIGURE 98. Access opening dimensions - continued

MIL-HDBK-759B

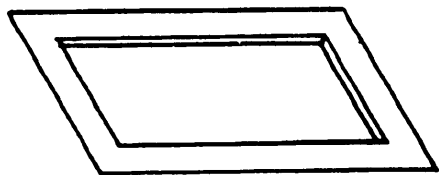

BEST--NO COVER
(USE WHENEVER POSSIBLE)

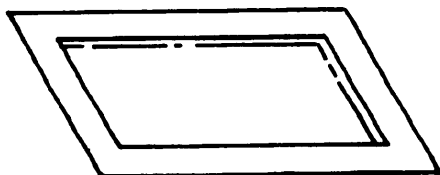

PERMANENT GLASS OR PLASTIC
COVER (USE WHERE ONLY VISUAL
INSPECTION IS REQUIRED).

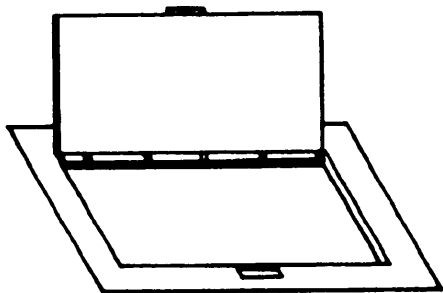

HINGED OR SLIDING COVER
(USE WHERE PHYSICAL ACCESS
IS REQUIRED AND WHERE DIRT
AND MOISTURE COULD BE A
PROBLEM),

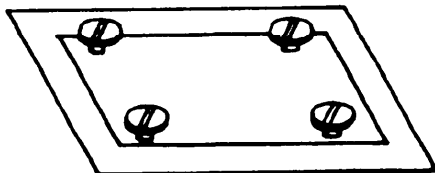

CAPTIVE QUICK-OPENING FASTENERS
(USE WHEN SPACE PREVENTS USE OF
HINGED COVER).

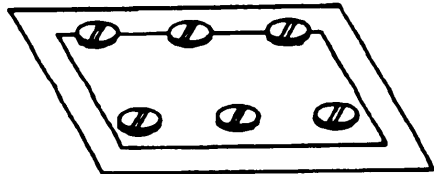

SCREWED-DOWN COVER
(USE ONLY WHEN STRESS OR
PRESSURIZATION REQUIRES
MINIMUM NUMBER OF SCREWS.

FIGURE 99. Covers and accesses

MIL-HDBK-759B

5.6.8.2 Access design. For ease of maintenance, some types of accesses are preferable to others. When structural, environmental, operational, and safety conditions permit, equipment should be left uncovered or exposed for maintenance, research test, service test, service points, and maintenance displays and controls. In some instances items can be designed to be semi-exposed with quick opening hoods and easily removed dust covers or cases. Uncovered openings should be used only when no environmental control is required and there is minimal danger to equipment or personnel. Work clearances around mounts and components should be considered as uncovered, limited-access openings. Covered, limited-access openings should be evaluated for the adequacy of their covers and fasteners. Riveted panels or doors are never acceptable designs for access points. Overall layout and design of equipment should not require removing permanently attached structures, even for infrequent maintenance.

5.6.8.3 Shape of accesses. Accesses should be whatever shape permits easiest passage of the required items, body appendages, or implements. The following aspects should be considered.

- a. Dimensions of the various items that must be replaced through the access.
- b. Protuberances, attachments, and handles on these items.
- c. Methods of grasping items during removal, and the required clearances.
- d. Requirements for clearance to do work within the compartment.
- e. The operator's visual requirements inside the compartment.

5.6.8.4 Size of accesses. Access sizes depend on the same considerations as access shapes. In general, one large access is better than two or more small ones but visual and physical access may be provided separately when structural or other considerations require it. When using stress doors or other access covers that are difficult to remove, an auxiliary smaller access should be provided to the frequently used test service points.

5.6.8.5 Location of accesses. Accesses should be located only on equipment surfaces that are accessible as normally installed for direct access and maximum convenience to perform maintenance. They should be placed on the same surfaces of the equipment as related displays, test points, and cables and at a safe distance from high voltage or dangerous moving parts. If not so designed, adequate insulation and shielding should be provided around such parts so personnel will not be injured. Accesses also should be located so that heavy or bulky items can be pulled out rather than lifted out.

MIL-HDBK-759B

5.6.9 Connectors.5.6.9.1 General considerations.

5.6.9.1.1 Compatibility. Connectors should be compatible with lines and cables (see 5.6.1 6), fasteners (see 5.6.1 1), mounting (see 5.6.1 8), environmental extremes and maintenance routines to which they will be subjected.

5.6.9.1.2 Selection and design. Connectors should be selected, designed, and mounted for fast, easy maintenance "operations, and easy removal and replacement of components and units. Connector design should also allow the most rapid set-up test and service of equipment and minimize danger to personnel and equipment contents, from pressures, contents, voltages, or lines during the release of connectors. Use of tools to perform connect or disconnect operations is not desirable from a human factors viewpoint; therefore, connections should be easily connected and disconnected by hand where possible.

5.6.9.1.3 Accessibility. Connectors should be accessible without disassembly or removal of other equipment or items. In proportion to how often they are operated, connectors used during preoperating checks should be the most accessible.

5.6.9.1.4 Location. Connectors should be located so that personnel can see and reach them easily to connect or disconnect them safely. Access to perform the function should be made available. Fluid connector leakage or accidental spillage should be controlled as necessary to prevent damage to equipment.

5.6.9.1.5 Separation. In general, connectors should be separated at least:

- a. 25 mm if used with bare fingers,
- b. 32 mm if used with both bare and gloved fingers,
- c. 75 mm if used with gloved or mittened hand, and
- d. as required for tool clearances.

5.6.9.1.6 Protection from damage. Connectors should be designed and located so they will not be damaged by moving personnel, shifting objects, opening doors, excessive tightening or manhandling during operation, shorts, arcing from foreign objects, erroneous connection, or handling after disconnection.

5.6.9.1.6.1 Connector protection. Protect connectors by recessing receptacles, by recessing delicate parts such as pins and keys within the connector so they are not exposed to harmful contact, and by providing protective caps, inserts, covers, cases, and shields as necessary.

MIL-HDBK-759B

5.6.9.1.6.2 Mismating and cross-connections. Connectors should be selected, designed, and installed so they cannot be mismated or cross-connected. The following means should be considered.

- a. Different sizes or types of connectors should be used.
- b. Cables should be arranged so their lengths correspond to the distances from the connector to the correct point of attachment.
- c. Wires should be arranged or separation blocks or other mounts should be provided, so the sequence of leads is obvious.
- d. Connectors should be polarized or different sizes of prongs and prong receptacles should be used so lines with different voltages cannot be mismatched. If different size prongs on prong receptacles are used the difference should be obvious enough to preclude attempts to mate and potentially damage connectors.
- e. Different, mutually incompatible and irreversible arrangement of guide pins, keys, or prongs should be used.
- f. Connectors and receptacles should be color-coded or labeled so mismating is unlikely.

5.6.9.1.7 Coding and identification. Connectors and associated parts and wiring should be coded and identified to key them to references in the job instructions and identify replaceable items and parts for reordering. Coding will expedite and facilitate maintenance and troubleshooting procedures, indicate the sequence routine or test procedures, and provide adequate warnings or cautions about using connectors.

5.6.9.1.8 Labeling. Label or code connectors and receptacles to ensure that:

- a. each plug is clearly identified with its receptacle,
- b. each wire is clearly identified with its terminal post or pin,
- c. test points are clearly identified by a unique mark or symbol,
- d. non-interchangeable connectors are clearly distinguishable, and
- e. the manner of connection or disconnection is obvious.

Plugs and receptacles should have painted strips, arrows, or other indications to show how connector interfaces should be aligned for proper connection. Terminal strips and circuit boards should be permanently marked to identify individual terminals and facilitate their replacement, and power receptacles for primary, secondary, or utility systems should be clearly labeled to prevent personnel injury or equipment damage.

MIL-HDBK-759B

5.6.9 .1.8.1 Location. Labels or codes on connectors and associated items should be located so that they are optimally visible during maintenance and are visible whether the connector is connected or disconnected. It should be possible to identify connectors without disconnecting them, and their positions should be consistent in relation to associated pins, terminals, and receptacles.

5.6.9 .1.8.2 Order of preference. The location of labels or codes is, in order of preference, first, directly on the connector and receptacle; second, on plates permanently attached to the connector and receptacle; third, on tabs or tapes attached to the connector. On receptacles, labels and codes should be placed on the surface or panel immediately adjacent to the receptacle and on recessed receptacles, on or near the access opening.

5.6.9.2 Classification of connectors (in order of preference).

5.6.9.2.1 Plug-in connectors. Plug-in connectors are the fastest and easiest to use, but they have low holding power; therefore plug-in connectors should not be used when accidental pulls on the cable may disconnect them. Plug-in connectors should be used for cables that are connected and disconnected frequently.

5.6.9.2.2 Quick-disconnect devices. Quick-disconnect devices have a variety of forms, including any type of connector that can be released by snap action, twisting up to a full turn, triggering a latch or spring device, or removing an external pin. Use quick-disconnect devices to connect items which must be disconnected or replaced frequently and items which must be replaced within critical readiness times.

5.6.9.2.3 Threaded connectors. Threaded connectors provide very secure connections, particularly when locked into place by set screws, retainers, or safety wires. They usually take longer to operate, depending on the number of turns and the types of tools they require. Threaded connectors should use the fewest turns that will satisfy holding requirements, be operable by hand if used for electrical connections, require only common hand tools (see 5.6.9. 1.2), and minimize the danger of accidentally loosening other connectors while working on one.

5.6.9.3 Electrical connectors.

5.6.9.3.1 Design and installation. Electrical plugs should be designed, installed, and mounted so that it is impossible to insert a plug into a wrong receptacle or into the correct receptacle the wrong way. Wherever possible, plugs should have multiple contacts to reduce the number of plugs and, consequently, the number of maintenance operations. Connectors should "plug-in" or secure with no more than one complete turn, especially with auxiliary or test equipment. Wiring should be routed through the plugs and receptacles so disconnection does not expose "hot" leads. Examples of "hot" contacts are socket contacts and female connectors. Receptacles should be "hot" and plugs should be "cold" when disconnected. Plugs should be self-locking or use safety catches rather than requiring safety wiring; plugs should have low insertion forces to minimize the possibility of damaging contact surfaces.

MIL-HDBK-759B

5.6.9.3.2 Alignment pins. Alignment keys or pins should be designed and located within the plug so that they extend beyond electrical pins to protect the pins from damage if the connector is misaligned and should be arranged asymmetrically to prevent incorrect plug insertions. All alignment pins for a given plug or series of plugs should be oriented in the same direction. If this conflicts with precautions against mismatching, pin orientations should differ consistently and systematically, for the technician's convenience.

5.6.9.3.3 Test points. Test points should be in plugs when test points are required but have not been provided elsewhere and in adapters to be inserted between the plug and receptacle if test points cannot be incorporated into the plug and no other test points are available. Test points should be accessible, with adequate clearance, when the plug or adapter is in its normal position. They should be coded and labeled so they can be seen clearly and identified easily in test procedures.

5.6.9.3.4 Coding. Coding connector receptacles and plugs is an important aid that helps operators associate input and output lines connecting different items of equipment. Some coding should be provided to associate each connector with its mate.

5.6.9.3.4.1 Color coding.

5.6.9.3.4.1.1 General.

- a. All colors used for coding should be readily discriminable from each other under operational lighting.
- b. Colored areas should be protected, in so far as possible, to keep the color from wearing off, fading, or disappearing.
- c. Permanently applied colors are preferable to adhesive tapes or bent-on tapes.
- d. If many connectors must be coded and there are not enough easily discriminable colors, matching patterns of colors and/or stripes should be used.
- e. Colors used to code connectors should be consistent and have the same meaning throughout the system.

5.6.9.3.4.1.2 Two color-coding methods. Either of two color-coding methods may be used for electrical connectors. Apply the same coding color to the face of the receptacle and the base of the plug or apply the same coding color to an area around the receptacle, and a band around the plug.

5.6.9.3.4.2 Shape codes. Connectors may be coded by using various shapes of matching plugs and receptacles (see Figure 100). Different shapes of alignment pins also may be used to differentiate connectors and to prevent mismatching.

MIL-HDBK-759B

5.6.9.3.4.3 Pin configurations. Still another coding method is using connectors with different numbers and configurations of pins (see Figure 101) or unique keyway slots so that it is physically impossible to mismatch connectors without breaking them. However, to prevent such damage, designers should select and code connectors so it is obvious which pairs do, or do not, match. Users should not be tempted nor encouraged to make mistakes. When a plug and a receptacle look generally similar but do not mate, use additional coding to differentiate them.

5.6.9.3.4.4 Size coding. Size coding also may help users associate plugs with their proper receptacles. Neighboring receptacles often have different sizes because of other requirements, but if they do not, consider using different sizes to help the user identify them.

5.6.9.3.5 Electrical conductors. Wires may be color coded by (in order of preference) solid-color insulation, solid-color insulation with colored-stripe tracer, or colored braid insulation with woven tracer. Every wire in a cable should be color coded over its entire length. There are 21 discriminably different patterns of solid colors and solids with striped tracers (see Table 67). For more than 21 wires, see MIL-STD-686. If a wire's color may become obscured, wires may be coded with numbered metal tags.

5.6.9.3.5.1 Number coding. Where wires are coded with numbers, the numbers should be repeated at least every 50 mm over the wire's entire length.

5.6.9.3.5.2 Specific wire coding information.

5.6.9.3.5.2.3 High-/low-tension power wire. Coding for hook-up wire is prescribed by MIL-STD-681.

5.6.9.3.5.2.2 Telephone, teletype, and telegraph wires. Coding for telephone, teletype, and telegraph wire is prescribed by MIL-STD-685.

5.6.9.3.5.2.3 High-/low-tension power cables. Coding for high-tension power cables is prescribed in MIL-C-3702; coding for low-tension power cables is prescribed in MIL-C-13486.

5.6.9.3.6 Fluid and gas connectors. Connectors for pipes, tubing, hoses, and similar connectors should be located and installed so that it is unnecessary to jack the equipment up to drain it, fill it, or perform other maintenance involving the connectors, and so that the technician can perform leakage tests easily and without danger. Tests should be planned so the technician's head is not in areas of extreme noise, vibration, or other danger while the equipment is running.

MIL-HDBK-759B

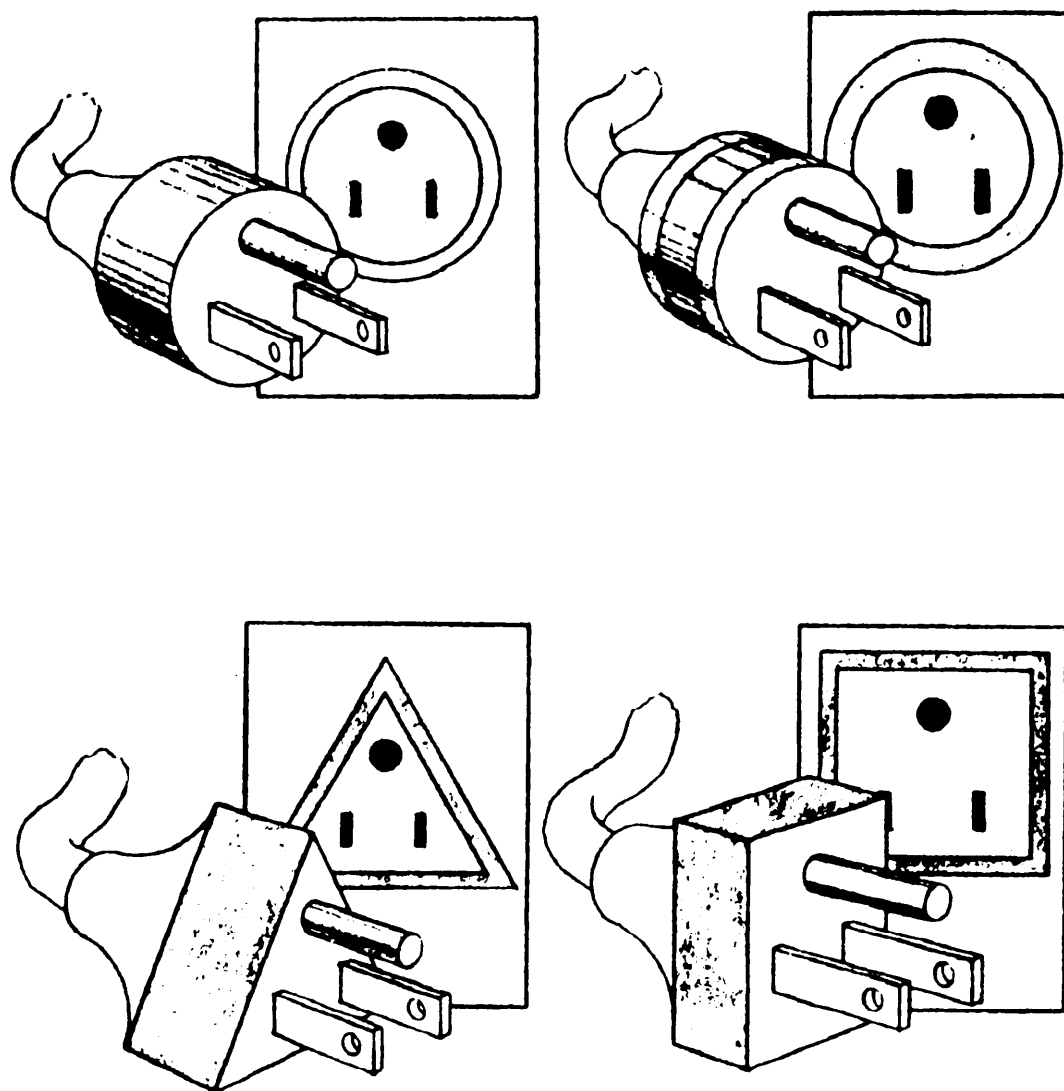

FIGURE 100. Coding of connectors

MIL-HDBK-759B

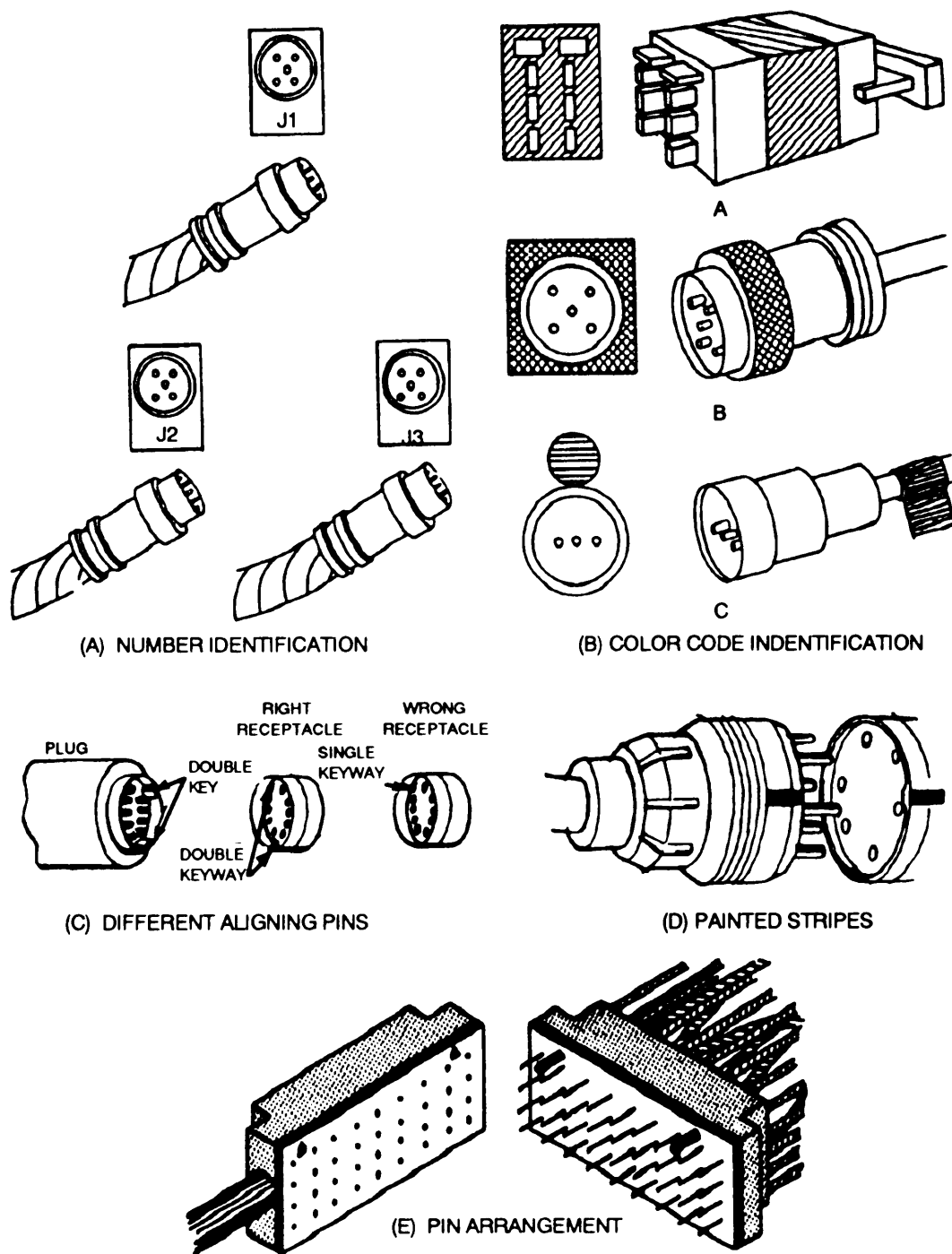

FIGURE 101. Methods of identifying plugs and receptacles to prevent mismatching

MIL-HDBK-759B

TABLE 67. Electrical cable coding

Instructions	Number of Conductor	Basic Color	Tracer
1, Find the number of the conductor to be color coded.	1	Black	None
	2	White	None
	3	Red	None
2. The colors at the right of the number are the appropriate combination for that conductor. For example, if a cable consists of 12 conductors, the twelfth color combination would be black with white tracer. The eight color combination would be red with black tracer. The fifth color combination would be orange without tracer, and so on.	4	Green	None
	5	Orange	None
	6	Blue	None
	7	White	Black
	8	Red	Black
	9	Green	Black
	10	Orange	Black
	11	Blue	Black
	12	Black	White
	13	Red	White
	14	Green	White
	15	Blue	White
	16	Black	Red
	17	White	Red
	18	Orange	Red
	19	Blue	Red
	20	Red	Green
	21	Orange	Green

NOTE: If a cable has concentrically laid conductors, the first combination or color applies to the center conductor. If a cable contains various sizes of conductors, the first color applies to the largest, continuing in order of conductor size.

5.6.9 .3.6.1 Gaskets and seals. Gaskets and seals should be selected and installed so that they can be replaced easily without removing other connector parts or disassembling other equipment. Part of a gasket or seal should be visible after it is installed as a check on failure to replace seals after disassembly. There should be job instructions giving the expected life of seals and gaskets and recommending when they should be changed.

5.6.9 .3.6.2 Hydraulic and pneumatic conductors. Hydraulic and pneumatic conductors should either be color coded (see Table 68) or coded by metal tags. Metal tags should be used where adverse conditions (such as grease or mud) could obscure colors; otherwise, color coding should be used.

MIL-HDBK-759B

5.6.10 Covers, cases and shields.

5.6.10.1 General. Covers, cases, and shields should be provided as necessary to divide enclosures into sections which are cleaned by different methods and to keep personnel from touching dangerous electrical or mechanical parts. They also protect delicate or sensitive equipment so it will not be damaged by movements of personnel, shifting cargo, loose objects, or installing and maintaining nearby assemblies.

TABLE 68. Hydraulic and pneumatic coding

Function	Color	Definition of Function
Intensified pressure	Black	Pressure in excess of supply pressure induced by a booster or intensifier,
Supply pressure	Red	Pressure of the power-actuating fluid.
Charging pressure	Intermittent Red	Pump-inlet pressure, higher than atmospheric pressure.
Reduced pressure	Intermittent Red	Auxiliary pressure lower than supply pressure.
Metered flow	Yellow	Fluid at a controlled flow rate (other than pump delivery).
Exhaust	Blue	Return of the power-actuating fluid to reservoir.
Intake	Green	Subatmospheric pressure, usually on the intake side of the pump,
Drain	Green	Return of leakage of control-actuating fluid to reservoir.
Inactive	Blank	Fluid within the circuit but not serving a functional purpose during the phase being represented.

5.6.10.1.1 Design for maintenance. Covers, cases, and shields should also be designed for fast, easy maintenance (Figure 102). Their maintenance characteristics depend largely on how they are fastened, the size, weight, and ease of handling, and whether handles or provisions for tool grips are provided. Other characteristics include the workspace and clearance around them and how often they must be opened or removed.

5.6.10.1.2 Characteristics.

- a. They should be lightweight if possible, but whatever size is necessary for the degree of enclosure and the accessibility required.

MIL-HDBK-759B

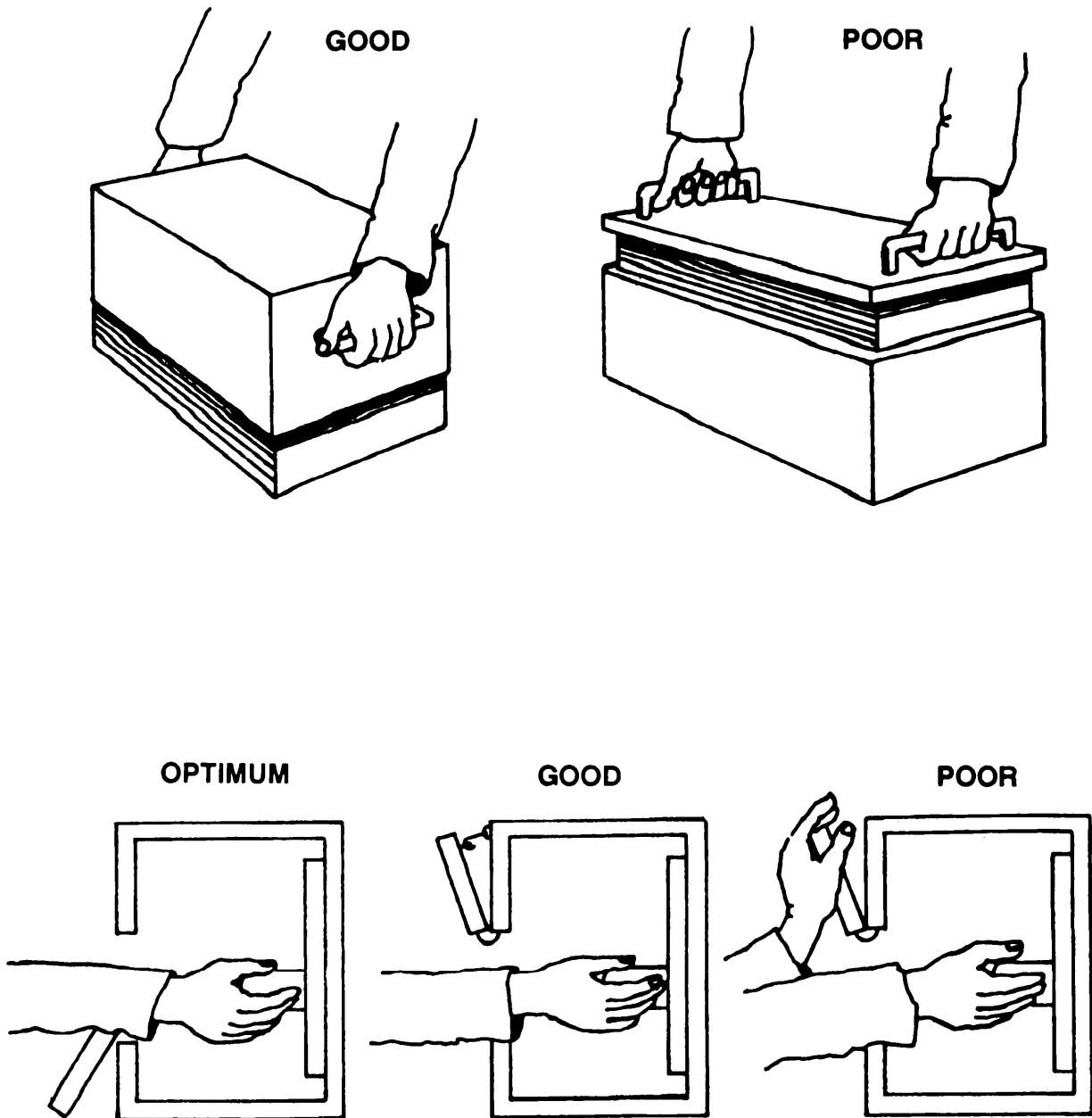

FIGURE 102. Covers and cases: design examples

- b. They should be openable, removable, and transportable by one hand, by one person, or by two persons, in that order of preference.
- c. Handles or tool grips should be provided if it is heavy, difficult to open, or difficult to handle.

MIL-HDBK-759B

- d. Enough clearance should be provided around enclosed components to prevent damage and to avoid requiring extremely fine or careful positioning and handling.
- e. They should be designed and located so bulkheads, brackets, or other units do not interfere with using them, and so they will not interfere with other maintenance operations when they are open.

5.6.10.1.3 Shape. Any appropriate shape for the degree of enclosure, accessibility, and clearances required may be used. It should be made obvious how the item must be positioned or mounted, and how enclosed delicate components are oriented in order to prevent damage during removal. Indentations or settling areas on top surfaces should be avoided to prevent rust and corrosion and keep dirt and grease from accumulating.

5.6.10.1.4 Location and mounts. Covers, cases, and shields should be designed, located, and mounted so that they can be removed and replaced if they are damaged and irregular extensions and accessories can be removed readily. They should be capable of being opened or removed as necessary without taking the equipment apart or removing auxiliary equipment. Props, retainers, or other supports should be located or mounted where required so the equipment will not be unbalanced when opened. When open, they should not obscure or interfere with controls, displays, test points, or connections used in working inside the access or enclosure. They also should have adequate stops and retainers to keep them from swinging against, or being dropped on, fragile equipment or on personnel, and have locking devices or retaining bars to hold them open if they might otherwise fall shut and cause damage, injury, or inconvenience. (This is particularly necessary when used in high winds.) If feasible, stowage provisions should be provided if the covers, cases, or shields are removable.

5.6.10.1.5 Fasteners. Fasteners for covers, cases, and shields should be selected, applied, and mounted so that they satisfy the preferences, criteria, and standardization aspects under "Fasteners" (see 5.6. 11). Hinges, latches, and catches should be used wherever possible to reduce handling and stowing of covers and cases. It should be obvious when a cover is not in place or is not securely fastened. Where possible, spring-loaded fasteners should be used so they can stand out or the cover itself stays ajar when it is not secure.

5.6.10.1.6 Labels and markings. Labels and markings on covers and cases should:

- a. present instructions on how to open, remove, and position them, unless the design itself makes operation obvious;
- b. clearly indicate the functions of units behind the enclosure or the functions which are performed through the access (such as "Battery," "Fuel Pump," "Oil Here");
- c. warn about any dangers or hazards involved in removing the cover or case, or working within the enclosure;

MIL-HDBK-759B

- d. indicate how units or service equipment should be oriented or connected to go through the opening (unless this is already obvious); and
- e. present instructions so they will be visible and properly oriented to a maintenance technician when the cover, door, or case is open.

5.6.10.2 Cases. Cases should be selected, designed, and mounted so that cases lift off of units, rather than units lifting out of cases, particularly when subassemblies are heavy (see Figure 102). They should be somewhat larger than the items they cover, so items inside can be removed and replaced easily without damaging wires or other components. They should have guidepins and tracks, as necessary, to help align the case, prevent it from cocking or binding, and to protect delicate or sensitive components from damage when the case is moved. Access to frequently used adjustment, test, and service points should be available so the case need not be removed for routine maintenance. All aspects and portions of the equipment that are significant for maintenance should be fully exposed when the case is removed. Rubber stripping or other sealing material should be selected and mounted so personnel will not damage it when the case is moved.

5.6.10.3 Covers. Covers are listed here in order of preference.

5.6.10.3.1 Hinged doors, hoods and caps. Hinged doors, hoods, and caps allow fastest and easiest access, with relatively few fasteners, and the cover is supported so the technician does not have to handle it. However, these covers do require “swinging space,” which may interfere with other operations or components. Where “swinging” or opening space is limited, double-hinged split doors should be used. Hinges should be placed at the bottom of the door, or a prop, catch, or latch should be provided to hold the door open, particularly if the door must be opened in high winds. When hinged doors are adjacent, they should open in the opposite directions to maximize accessibility. Hinged caps should be used over service or test points so they will not interfere with inserting or attaching service or test equipment. Stops or retainers should be used as necessary to keep doors from swinging into adjacent controls or fragile components, and so they will not spring their hinges.

5.6.10.3.2 Sliding doors and caps. Sliding doors or caps are particularly useful where “swinging space” is limited. Small sliding caps are useful for small accesses that do not require a tight seal. When using sliding doors and caps, they should lock positively, be designed so they will not jam or stick, and be easy to use. Personnel should be able to use them without tools. Opening or closing them should not interfere with, damage, or make potentially harmful contact with wires or other equipment items.

5.6.10.3.3 Removable doors, plates, and caps. Removable doors, plates, or caps require little space for opening and, once removed, do not interfere with workspace. However, handling them takes time and effort. When using removable covers, tongue-and-slot or similar catches should be used wherever possible for small plates, doors, and caps, to minimize the number of fasteners required. If small plates and caps are likely to be misplaced or damaged, secure them with retainer chains (see 5.6.11). If a removable plate must be attached in a certain way, it should be designed so it cannot be attached improperly. For example, use an asymmetric shape, locate mounting

MIL-HDBK-759B

holes asymmetrically, or code both plate and structure with labels that will align when the plate is properly installed.

5.6.10.3.4 Removable panels or sections. Removable panels or sections give access to whole sides of equipment. They discourage non-maintenance personnel from opening the access. They do not require "swinging space," but they are easily damaged and awkward to handle. They may also interfere with maintenance. When used, panels that must be removed for maintenance should be held with a minimum of combination-head, captive fasteners. Spring-loaded, quarter-turn fasteners are particularly recommended, and it should be apparent when fasteners have been released. Panels and sections should be designed so one person can carry them and install or remove them with common hand tools, and should have handles to facilitate removal, handling, and replacement. It should not be necessary to disconnect wires or components from a panel before removing it. If such items are attached to the panel, it should be hinged so they need not be removed.

5.6.11 Fasteners.

5.6.11.1 General. The design, selection, or application of fasteners should consider the workspace, tool clearance, and wrenching space needed around the fastener, and the types of tools required to operate the fastener, depending on the type of fastener, application, and location. How often the tool will be used and the time available for tasks involving operation of the fasteners are other considerations. The fasteners also will have to be used by personnel who may be wearing arctic gloves or mittens.

5.6.11.1.1 Selection. Fasteners are available in a wide variety of types and sizes, and new types are always appearing on the market. Before selecting fasteners, review the varieties available. They should be standardized wherever possible to reduce spare parts and minimize the danger that personnel will damage them by using the wrong tool or fastener. Fasteners should be selected for durability, easy operation, speed, and easy replacement.

5.6.11.1.2 Minimize fasteners and required tools. Minimize the number of types and sizes of fasteners within the system by using only a few basic types and sizes which are readily distinguishable from each other (see Figure 103) and using the same type and size of fastener consistently for a given application. For example, all mounting bolts should be the same for a given type of item. Another way to minimize the number and types of sizes is by making certain that screws, bolts, and nuts with different threads also have clearly different physical sizes so they will not be interchanged, by avoiding fasteners that require special tools, and by selecting fasteners that can be operated by hand or by common hand tools.

MIL-HDBK-759B

TYPE	DESCRIPTION
	<p>Adjustable pawl fastener.</p> <p>As knob is tightened, the pawl moves along its shaft to pull back against the frame. 90° rotation locks, unlocks fastener.</p>
	<p>"Dzus" type fastener with screwdriver slot.</p> <p>Three-piece 1/4-turn fastener. Spring protects against vibration. 90° rotation locks, unlocks fastener.</p>
	<p>Wing head. "Dzus" type.</p> <p>90° rotation locks, unlocks fastener.</p>
	<p>Captive fastener with knurled, slotted head.</p> <p>Retaining washer holds the threaded screw captive.</p>
	<p>Draw-hook latch.</p> <p>Two-piece, spring latch, base unit and striker. When engagement loop is hooked over striker, depressing lever closes unit against force of springs. Lever is raised to unhook.</p>
	<p>Trigger-action latch.</p> <p>One-piece, bolt latch. Depressing trigger releases bolt, which swings 90° under spring action and opens latch. To close, move bolt back into position.</p>
	<p>Snapslide latch.</p> <p>One-piece snapslide. Latch is opened by pulling lever back with finger to engage release lever.</p>
	<p>Hook latch.</p> <p>Hook engages knob on striker plate. Handle is pulled up locking in place. To release, reverse procedure.</p>

FIGURE 103. Fastener examples

MIL-HDBK-759B

5.6.11.1.3 One-hand or one-tool operation. Nuts and bolts, particularly those which are operated frequently or which are not very accessible, should be mounted so they can be operated with one hand or one tool and recesses should be provided to hold either the nut or the bolt. Either the nut or the bolt should be attached semi-permanently, and they should not interfere with each other or with other components during release. Nuts and bolts should not be hazards to personnel, wires, or hoses and should have adequate hand or tool clearance for easy operation. It should be considered that it may take two hands or power tools to manipulate, breakaway, or remove stuck fasteners. Fasteners that are normally operated by hand should be durable enough that they can be turned with a wrench.

5.6.11.1.4 Other considerations. Consider how stripped, worn, or damaged fasteners can be replaced. Fasteners (studs) which are an integral part of the housing should be avoided. Fastener mounting holes or other tolerances should be large enough to allow "starting" fasteners without perfect alignment. Attach hinges, catches, latches, locks, and other quick-disconnect devices with small bolts, or screws, not with rivets.

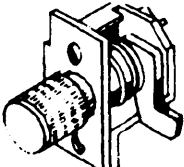
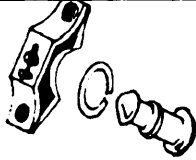
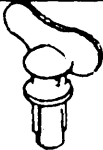
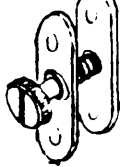
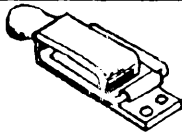
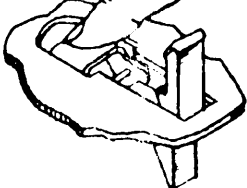
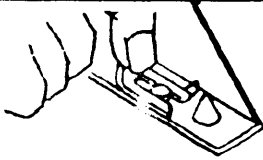
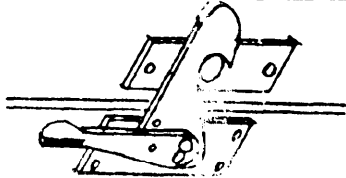
5.6.11.2 Types of fasteners (in order of preference).

5.6.11.2.1 Quick-connect/-disconnect devices. These devices are fast and easy to use, do not require tools, may be operated with one hand, and are very good for securing plug-in components, small components, and covers. However, their holding power is low, and they cannot be used where a smooth surface is required. The factors listed below should be considered in selecting quick-connect/-disconnect fasteners.

- a. These fasteners should be used wherever possible when components must be dismantled or removed frequently.
- b. These fasteners should fasten and release easily, without requiring tools.
- c. They should fasten or unfasten with a single motion of the hand.
- d. It should be obvious when they are not correctly engaged.
- e. When there are many of these fasteners, prevent disconnections by giving the female section a color or shape code, location, or size so it will be attached only to the correct male section.

5.6.11.2.2 Latches and catches. These items are very fast and easy to use, do not require tools, and have good holding power; they are especially good for large units, panels, covers, and cases. They cannot be used where a smooth surface is required. The factors listed below should be considered in selecting latches and catches.

- a. Long-latch catches should be used to minimize inadvertent releasing of the latch.

MIL-HDBK-759B

- b. Catches should be spring-loaded so they lock on contact rather than requiring positive locking.
- c. If the latch has a handle, the latch release should be located on, or near, the handle so it can be operated with one hand.
- d. Latches and catches should be evaluated for snap down and release forces that could be hazardous to handle during operation.

5.6.11.2.3 Captive fasteners. Captive fasteners are slower and more difficult to use, depending upon type, and usually require using common hand tools, but they stay in place, saving time that would otherwise be wasted handling and looking for bolts and screws, and can be operated with one hand. The factors listed below should be considered in selecting captive fasteners.

- a. Captive fasteners should be used when “lost” screws, bolts, or nuts might cause a malfunction or excessive maintenance time.
- b. Fasteners should be used which can be operated by hand or with a common hand tool and which can be replaced easily if they are damaged.
- c. Captive fasteners of the quarter-turn type should be self-locking and spring-loaded.

5.6.11.2.4 Regular screws. Round, square, or flat-head screws take longer to use and are subject to loss, damage, stripping, and misapplication. Square-head screws are generally preferable to round or flat ones; they provide better tool contact, have sturdier slots, and can be removed with wrenches. If personnel must drive screws blindly, provide a guide in the assembly to help keep the screwdriver positioned properly. Screw heads should have deep slots that will resist damage, and should be used only when personnel can use screwdrivers in a “straight-in” fashion. Personnel should not be required to use offset screwdrivers.

5.6.11.2.5 Bolts and nuts. Bolts are usually slow and difficult to use. Personnel must have access to both ends of the bolt, use both hands, and often use two tools. Also, starting nuts require precise movements. There are many loose parts to handle and Jose such as nuts and washers. Design considerations should include keeping bolts as short as possible, so they will not snag personnel or equipment. Coarse threads are preferable to fine threads for low torques and reduce the possibility of cross-threading. Left-hand threads should be avoided unless system requirements demand them. If used, both bolts and nuts should be identified by clearly marking, or shape or color coding. Wing nuts (preferably) or knurled nuts should be used for low-torque applications, because they do not require tools.

5.6.11.2.6 Combination-head bolts and screws. Combination-head bolts and screws are preferable to other screws or bolts because they can be operated with either a wrench or a screwdriver, and there is less danger of damaged slots and stuck fasteners. In general, slotted hexagon heads are preferable to slotted knurled heads.

MIL-HDBK-759B

5.6.11.2.7 Internal-wrenching screws and bolts. Internal-wrenching screws and bolts (socket heads) allow higher torque, better tool grip, and less wrenching space, but require special tools, are easily damaged, and are difficult to remove if damaged. They also become filled with ice and frozen mud. The number of different sizes should be limited to minimize the number of special tools; one size is preferred. Fasteners with deep slots should be selected to reduce the danger of damaged fasteners.

5.6.11.2.8 Rivets. Rivets are very hard and time-consuming to remove. They should not be used on any part which may require removal.

5.6.11.2.9 Cotter key. Keys and pins should fit snugly, but they should not have to be driven in or out. Cotter keys should have large heads for easy removal.

5.6.11.2.10 Safety wire. Use safety wire only where self-locking fasteners cannot withstand the expected vibration or stress. Attach safety wire so it is easy to remove and replace.

5.6.11.2.11 Retainer ring. Rings which become difficult to remove and replace when they are worn should be avoided. Rings which hold with a positive snap action should be used when possible.

5.6.11.2.12 Retainer chains. Retainer chains should be used to:

- a. keep hatches or doors from opening too far and springing their hinges,
- b. turn doors or covers into useful shelves for the technician,
- c. prevent small covers, plates, or caps from being misplaced,
- d. secure small, special tools where they will be used,
- e. secure objects which might otherwise fall and injure personnel, and
- f. secure removable pins to prevent loss.

The selection of retainer chains for use in design should consider link, sash, or woven-mesh chains. Bead-link chain should be avoided because it breaks more easily than other types. Chains should be attached with screws or bolts; attach them strongly and positively, but so they can be disconnected easily when required. Eyelets should be provided at both ends of the chain for attaching to the fasteners and chains should not be longer than their function requires.

5.6.12 Equipment units access checklist. The following checklist summarizes some of the important features to be considered in the design of equipment units. The checklist contains several items which were not discussed separately in the text. These items are included here because their necessity in the design is so obvious that they might otherwise be inadvertently overlooked. In using the checklist, if the answer to any question is no, the design should be restudied to ascertain the need for correction.

MIL-HDBK-759B

- a. Are clearance holes for mounting screws in cover plates and shields oversize to obviate need for perfect alignment?
- b. Are cases designed to be lifted off units rather than units lifted out of cases?
- c. Are cases made larger than units they cover to preclude damage to wires and components?
- d. Are guides or tracks provided to prevent cases cocking to one side?
- e. If the method of opening a cover is not obvious, is an instruction plate attached to the outside of the cover?
- f. When covers are not in place and secure, are means provided to make it obvious?
- g. Are no more than six fasteners used to secure the case?
- h. Are the same type fasteners used for all covers and cases on a given piece of equipment?
- i. Is ventilation-hole screening of small enough mesh provided to prevent entry of probes or conductors that could inadvertently contact high voltages?
- j. When the sealing edges of a case must be slid over sealing material (such as rubber stripping), does the sealing material adhere tightly enough to prevent it from buckling or tearing?

5.6.13 Handles.

5.6.13.1 Desire and locations. The primary consideration in the design and location of handles should be to allow the device to be easily handled and carried. Some secondary considerations are to guard against accidental operation of controls to protect delicate parts of instrument faces, to serve as locking devices to secure components in place, to serve as protective supports or stands so they can be used as maintenance stands when items are inverted, and to allow the device to be easily handled and carried.

5.6.13.2 Dimensions, location, and position. The dimensions (see Figure 104), location, and position of a handle depends on:

MI L-HDBK-759B

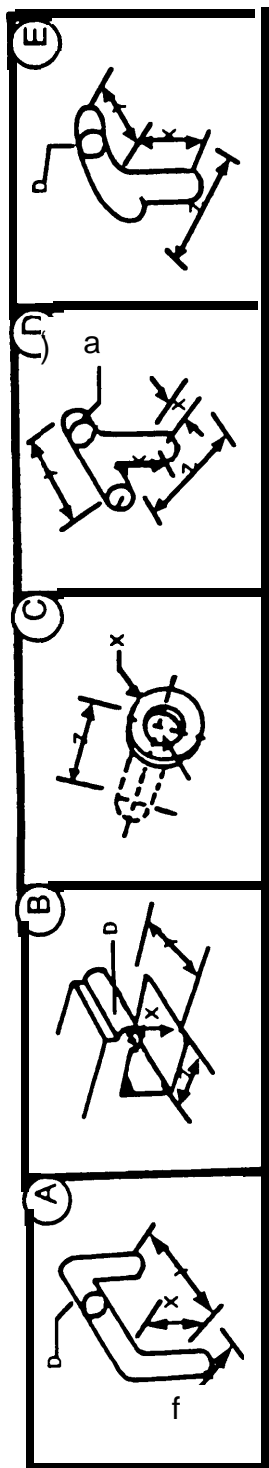

Type of handle:	Dimensions (mm)			(Mittened Hand)
	(Bare Hand)	(Gloved Hand)		
	X	Y	Z	X
A. Two-Finger Bar	32	65	75	Not Applicable
B. One-Hand Bar	48	110	75	75
C. Two-Hand Bar	48	215	75	75
D. Two-Finger Recess	32	65	50	Not Applicable
E. One-Hand Recess	50	110	90	90
Finger-Tip Recess	19		13	Not Applicable
One-Finger Recess	32		50	Not Applicable
T-Bar	38	100	75	Not Applicable
J-Bar	50	100	75	75

Curvature of Handle or Edge:

Weight of Item	Diameter (minimum)
up to 6.8 kg	D -- 6 mm
6.8 to 9.0 kg	D -- 13 mm
9.0 to 18.0 kg	D -- 19 mm
Over 18.0 kg	D -- 25 mm
T-bar Post	T -- 13 mm

Gripping efficiency is best if finger can curl around handle or edge to any angle of 120 degrees or more. (For smaller (miniaturized) type components particularly, dimensions should conform as close as practicable.)

FIGURE 104. Handle dimensions

MIL-HDBK-759B

- a. weight of the item,
- b. number of persons or hands required to lift or carry it,
- c. type of clothing and gloves users wear,
- d. the item's operational position relative to other items and obstructions,
- e. how the item is handled or positioned,
- f. how often and how far the item must be carried, and
- g. additional uses for the handle.

5.6.13.3 Location. Handles should be located so that if there is only one handle, it is as optimally placed to the center of gravity as is feasible. If there are two or four handles, they should be equidistant from the center of gravity, and their locations should not interfere with operating or maintaining the equipment. There should be at least 65 mm of clearance between handles and obstructions. If it must be pulled from a rack, handles should be placed on the front of a panel and should be able to be held comfortably. The item which is carried should ride clear of the legs of personnel.

5.6.13.4 Other considerations. Hand-shaped handles should be used when items must be carried frequently or for long periods, to prevent undue side pressure on the fingers. Recessed, concealed, or folding handles may be used to conserve space, but they should be accessible without tools and remain securely folded when not in use. Handles, lugs, and other handling gear (casters, push bars) should be permanent parts of the equipment case, and hoist lugs (lifting-eyes) should be provided on all equipment weighing more than 68 kg. "LIFT HERE" should be marked adjacent to each lug, and a minimum of 100 mm space should be allowed around the lifting eyes for convenient use.

5.6.14 Drawers and racks for equipment units.

5.6.14.1 General. Pull-out, roll-out, or slide-out drawers, shelves, racks or other hinged or sliding assemblies (see Figure 105) should be provided as necessary and wherever practicable to optimize workspace, tool clearance, and accessibility, and reduce the need for the technician to handle fragile or sensitive items. This would also facilitate the handling and/or positioning of heavy or awkward items as well as maintenance of items which are frequently moved from the installed position for checking, servicing, or repair. Pull-out, or slide-out racks and drawers should be designed in the manner listed below.

- a. A minimum number of operations are required to open or release them.
- b. They operate with a force less than 178 N.
- c. A smooth-bearing assembly facilitates operations, as needed.

MIL-HDBK-759B

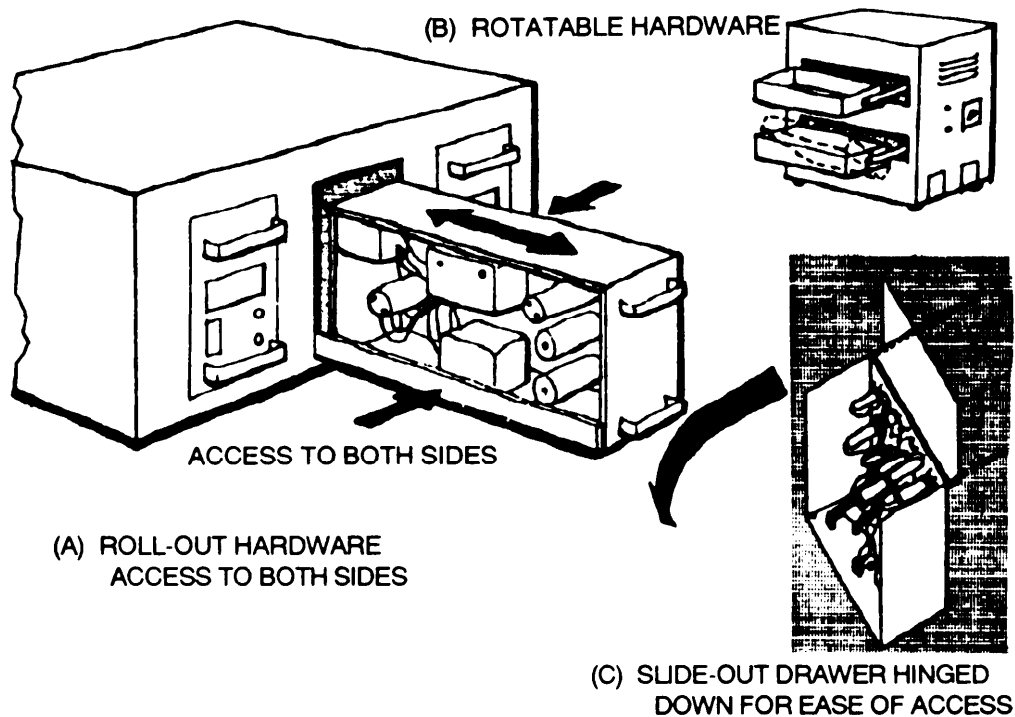

FIGURE 105. Pull-out, roll-out, and slide-out drawers for components requiring frequent checks

- d. They lock automatically in both servicing and operating positions.
- e. Handles are provided, as necessary, to facilitate operation and handling.
- f. Assemblies may be opened without breaking internal connections which are necessary for required maintenance.
- g. Extension cables or hoses are provided, as necessary, to allow completely removable assemblies to be checked in a convenient location.
- h. Guards and shields are provided, as necessary, to prevent damage to fragile or sensitive parts when the assembly is moved.

5.6.14.2 Retaining devices. Rests, limit stops, guards, and/or retaining devices should be provided as part of the basic chassis. These devices should prevent the assembly from being dropped, prevent heavy assemblies from

MIL-HDBK-759B

tipping the equipment, and allow complete and convenient removal of the assembly. These devices also should allow the assembly to open its full distance and remain open without being held.

5.6.14.3 Internal connectors. Where internal connection is not required during maintenance, connectors to a drawer or shelf may be attached to the assembly itself, so that closing the assembly effects connection. This requires that the connector parts be mounted on the assembly and rear wall and locks be provided to ensure that connectors remain engaged. Guides should be provided to ensure proper orientation of the assembly prior to pin engagement. If necessary, insulation should be provided to ensure safety.

5.6.15 Handling equipment.

5.6.15.1 General. Handling equipment includes ground support equipment used for handling, lifting, and positioning tasks required during system maintenance.

5.6.15.2 Jacks.

5.6.15.2.1 General. Jacks should be designed so they can be transported, handled, and stored easily. Small jacks, that one person must lift and carry, should not weigh more than 18 kg.

5.6.15.2.2 Handles. Jack handles should be designed so they can be removed or folded when the jack is not in use.

5.6.15.2.3 Labels. Jacks should be labeled to indicate the direction to turn the jack handle for raising and lowering, and the load they are designed to carry.

5.6.15.2.4 Hydraulic jacks. On hydraulic jacks, there should be mechanical safety-locking devices to keep the load from falling if the hydraulic system fails. Only non-flammable hydraulic fluid should be used in jacks.

5.6.15.2.5 Jacking points. Jacking points should be conspicuously labeled on equipment.

5.6.15.3 Cranes.

5.6.15.3.1 Crane booms. Sections of crane booms should have hook eyes at their center of gravity for easier assembly and disassembly. Where feasible, the boom length should be adjustable to make the equipment more versatile.

5.6.15.3.1.1 Boom indicators and controls. The main boom angle-indicator display should be easily visible to the operator and coded to alert the operator when there is danger of exceeding the maximum load angle. Load capacity, in kg, should be indicated on the equipment and audible warning devices should be provided when load is exceeded. Boom controls should have labels indicating their functions and direction of motion and be placed in the most accessible area for the 5th through 95th percentile operator when wearing cold weather clothing. These controls should be

MIL-HDBK-759B

spring-loaded so they return to the stop position when released. Latches on control levers should not cause delay in operation.

5.6.15.3.2 Hooks. Crane hooks should have handles so operators can hold or guide hooks during lifting, without danger or injury. The hook mouths should have safety-closure locking devices that are easy to open or close.

5.6.15.3.3 Other considerations.

- a. The crane operator's station should be located where the operator will have the best view of the load, the ground, and other equipment in the vicinity.
- b. Retainers or locks used to keep booms in place during transport should be identified clearly and unambiguously.
- c. Fail-safe load holding devices should be provided to reduce dropping objects.
- d. Cranes that rotate on a turntable should be provided with a mechanical safe.
- e. Foot-operated controls and brake pedals that require locking should lock by foot action only. Pedals should rise from a depressed position in a backward as well as vertical movement.

5.6.15.4 Hoists.

5.6.15.4.1 General. Hoists should have an automatic cutoff of power to stop lifting when a bind occurs. Moving parts, such as belts, chains, and gears should be covered to prevent personnel from accidentally coming in contact with them.

5.6.15.4.2 Control box. The hoist control box should be lightweight and designed to be hand-held so the operator may reach the "up" and "down" control while holding the box securely and comfortably. Where a push button control is used, it should be spring-loaded to the "off" position and recessed. The "up" and "down" hoist controls should be clearly labeled, preferably on the control.

5.6.16 Lines and cables.

5.6.16.1 General. Lines and cables should be selected, designed, marked, bound, routed, and installed so the following operations can be performed quickly.

- a. Troubleshooting, testing, checking, and isolating malfunctions.
- b. Tracing, removing, repairing, and replacing cables.
- c. Removing and replacing other items and components.
- d. Connecting and disconnecting.

MIL-HDBK-759B

5.6.16.1.1 Compatibility. Lines and cables should be compatible with interfacing connectors (see 5.6.9), fasteners (see 5.6. 11), accesses (see 5.6.8), and environmental extremes to which they will be subjected.

5.6.16.1.2 Routing. Lines and cables should be routed and mounted so that they fulfill the conditions listed below.

- a. They should be accessible without disassembling or removing other equipment.
- b. Points of connection, mounting, splicing, or testing should be especially accessible.
- c. They can be removed and replaced completely if they are damaged.
- d. There are accesses and clearances for removing and replacing them.
- e. Personnel will not use them for handholds or footsteps and will not step or walk on them.
- f. Moving and rotating parts will not snag them, and so they do not interfere with normal operations.
- g. Cables routed through metal partitions should be protected by use of insulating grommets.
- h. Foreign objects, such as flying stones, will not damage them.
- i. Cables routed in areas where potential risks for degradation are high (passageways, across walkways, exposure to adverse conditions such as oil, blasts, heat) should be protected by conduit.

5.6.16.1.3 Clamps and plates. Clamps or plates that mount lines and cables should be spaced not more than 610 mm apart so personnel can install or remove one with each hand with or without common hand tools, and have heat-insulating liners so they do not become hot enough that personnel could be burned. They should be the quick-release hinged or spring type if cables are removed frequently. Hinged clamps are preferable, because they support the weight of the line during maintenance, freeing the technician's hands for other tasks. For overhead mounting, a spring clamp should be used with a hinged-locking latch over the clamp's open side to prevent accidents.

MIL-HDBK-759B

5.6.16.1.4 Handling and storing extension cables. There should be adequate provision for handling and storing extension cables and cables used with ground power, service, and test equipment. Adequate, covered space should be provided for storing lines and cables in support equipment. Suitable racks, hooks, or cable winders should be available and conveniently accessible in the storage space to hold lines and cables. Reels or reel carts should be used for handling large, heavy, or very long lines and cables. Automatic or power tensioning or rewinding reels should be used where possible to make handling easier. Wheeled or mobile supports also should be used for extra-large lines and cables that must be moved frequently.

5.6.16.2 Fluid and gas lines.

5.6.16.2.1 Personnel and equipment protection. Lines should be kept from spraying or draining fluid on personnel or equipment when they are disconnected by locating connections away from work areas and sensitive components, shielding sensitive components where required, and providing drains and bleed fittings so lines can be drained, or repressurized, before they are disconnected. Cutoff valves should be provided at appropriate locations in the system to permit isolation or drainage of the system for maintenance or emergency purposes.

5.6.16.2.2 Mounting and installation. Lines should be mounted and installed so that rigid lines with fittings do not have to be backed-off before they can be disconnected. Flexible tubing, rather than rigid lines, should be used where feasible because it allows easier handling, can be backed-off easily, and is easier to thread through equipment when it must be replaced. Flexible hose, rather than pipes or tubing, should be used when there is only limited space for removing, replacing, or handling lines. It can be backed-off or pushed aside for access to other components. Fuel lines should not be routed above electrical cables or above hot pipes or areas.

5.6.16.2.3 Prevention of mismatching. To avoid the possibility of mismatching connectors during service or maintenance, standardize fittings so lines which differ in content cannot be interchanged. Lines should be coded by arrangement, size, shape, and color as necessary, and colored bands should be used to identify all lines that carry fluids.

5.6.16.2.4 Drainage problems. Prevent drainage problems by:

- a. designing lines so they can be emptied completely when necessary,
- b. making bends horizontal, rather than vertical, to avoid fluid traps,
- c. avoiding low points or dips in lines that make them difficult to drain,
- d. providing special drains at low points where necessary, and
- e. providing cutoff valves at appropriate points in the system to permit isolation or drainage of particular lines for maintenance or emergency purposes.

MIL-HDBK-759B

5.6.16.2.5 Supports. Adequate supports should be provided for lines from external service or test equipment, or where extensions will be attached for other purposes. These supports should withstand not only the initial pressure through the line and the weight of its external extensions, but the rigors of handling and repeated connection and disconnection as well.

5.6.16.3 Electrical wires and cables.

5.6.16.3.1 Routing. The layout and routing of wires should be made as simple and logical as possible by combining wires into cables (preferable) or into harnesses, minimizing the number of wires, harnesses, and cables, and grouping conductors into cables, and within cables or harnesses, by their functions and relationships to replaceable items. Electrical wires, harnesses, and cables should be mounted so there is adequate accessibility through raceways, conduits, and junction boxes. Electrical wires and cables should be mounted over, rather than under, pipes or fluid containers.

5.6.16.3.2 Coding and labeling. Conductors should be coded and labeled as provided in 5.6.9, so each conductor can be identified throughout the length of each cable or harness, wherever tracing is required, and so codes and labels correspond to connector designations, test point designations, and connector functions.

5.6.16.3.3 Leads. Leads should not be longer than necessary, but their lengths should allow easy connection and disconnection with enough slack to back wires away from attachment points so units can be removed easily. They should be long enough to allow slack so terminal fittings can be replaced at least twice, and preferably three times (if electrical considerations permit). Leads also should be long enough to permit units which are difficult to handle when mounted to be moved to a more convenient position for connection or disconnection.

5.6.16.3.3.1 Mounting. Leads should be mounted so they are separated far enough to clear the technician's hand or any tool required for checking or connecting them, and oriented, where possible, so they will not be connected incorrectly or "crossed."

5.6.16.3.4 Plastic covering. Consider using clear plastic covering to insulate leads on cables so that breaks in internal wiring can readily be seen. Neoprene-covered, rather than aluminum-sheathed cable, should be used in areas where intense vibration or corrosive substances may cause failures. These coverings should remain flexible at low temperatures.

5.6.16.3.5 Wires. When polyvinyl wire is used, care should be taken so there will be no cold flow of the insulation resulting from tightness of the lacing or mounting. High-temperature wire should be used when wires are routed near ducts carrying pressures over 3.5×10^5 Pascals and/or temperatures above 200°C. Wires and coverings also should remain flexible at the low temperatures encountered in cold regions. Color code or number code insulated wire and cable in accordance with MIL-STD-195 and MIL-STD-681.

MIL-HDBK-759B

5.6.16.3.6 Metallic shielding. Metallic shielding, unprotected by outer insulation, should be secured to prevent the shielding from contacting exposed terminals or conductors.

5.6.16.3.7 Extension cables. Use extension cables to:

- a. increase efficiency and make maintenance easier,
- b. test assemblies or components without removing them,
- c. check each functioning unit in a convenient place,
- d. allow parking support equipment or setting it in a convenient place, and
- e. serve as many related functions as possible, avoiding the possibility of misuse or disconnection.

5.6.16.4 Cable routing.

5.6.16.4.1 General. Interconnecting communication cables should be routed to minimize the possibility of their use as handholds or steps. A protective guard should be placed over the cables where the possibility of such use exists.

5.6.16.4.2 Maintenance. Cable routing should facilitate ease of maintenance by ensuring that each unit can be checked in a convenient place (extension cables should be provided when necessary). Units in drawers and slide-out racks should be able to be pulled out to be worked on without breaking electrical connections. Connectors should be reached easily for replacement or repair, and units that are difficult to connect where they are mounted should be capable of being moved to a more convenient position for connecting and disconnecting.

5.6.16.4.3 Cable length. The length of cables should be the same for each installation of a given type of electronic equipment if the circuit might be affected by differences in the length of the cable. (Even if a unit can be adjusted to compensate for differences in the length of the cable, using different lengths of cable means that an adjustment made on the bench might be out of tolerance when the unit is installed.)

5.6.16.4.4 "Fan out" in junction boxes. Cables should "fan out" in junction boxes for easy inspection, especially if there are no other test points in the circuits (Figure 106). Each terminal in the junction box should be clearly labeled and easy to reach with test probes.

MIL-HDBK-759B

5.6.16.4.5 **Harnesses.** Cable harnesses should be designed so they can be built in a shop or factory and installed as a package.

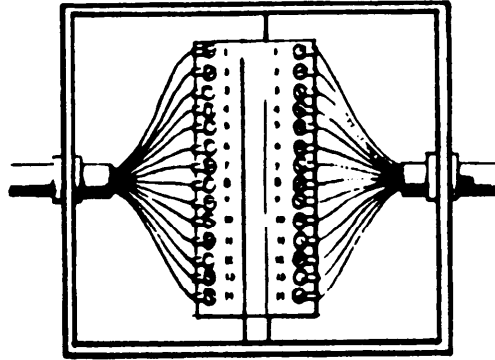

FIGURE 106. Cable inspection

5.6.16.4.6 **Preformed cables.** Use preformed cables when possible (see Figure 107). They permit flexible, more efficient assembly methods and minimize the chances of making wiring errors. They also permit testing and coding of the entire cable before installation. Once the cable is placed in position on the chassis, the leads can be connected without the usual interference and confusion caused by stray wires.

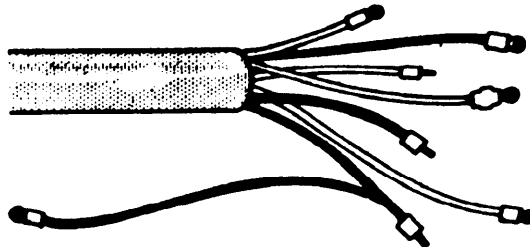

FIGURE 107. Preformed cables

5.6.16.4.7 **Design recommendations.**

- a. Route cables so that they are not pinched by doors, lids and slides, are not walked on or used for handholds (see Figure 108), and are accessible to the technician, by not being under floorboards, behind panels or components that are difficult to remove, or routed through congested areas, and need not be bent or unbent sharply when connected or disconnected (see Figures 109 and 110).

MIL-HDBK-759B

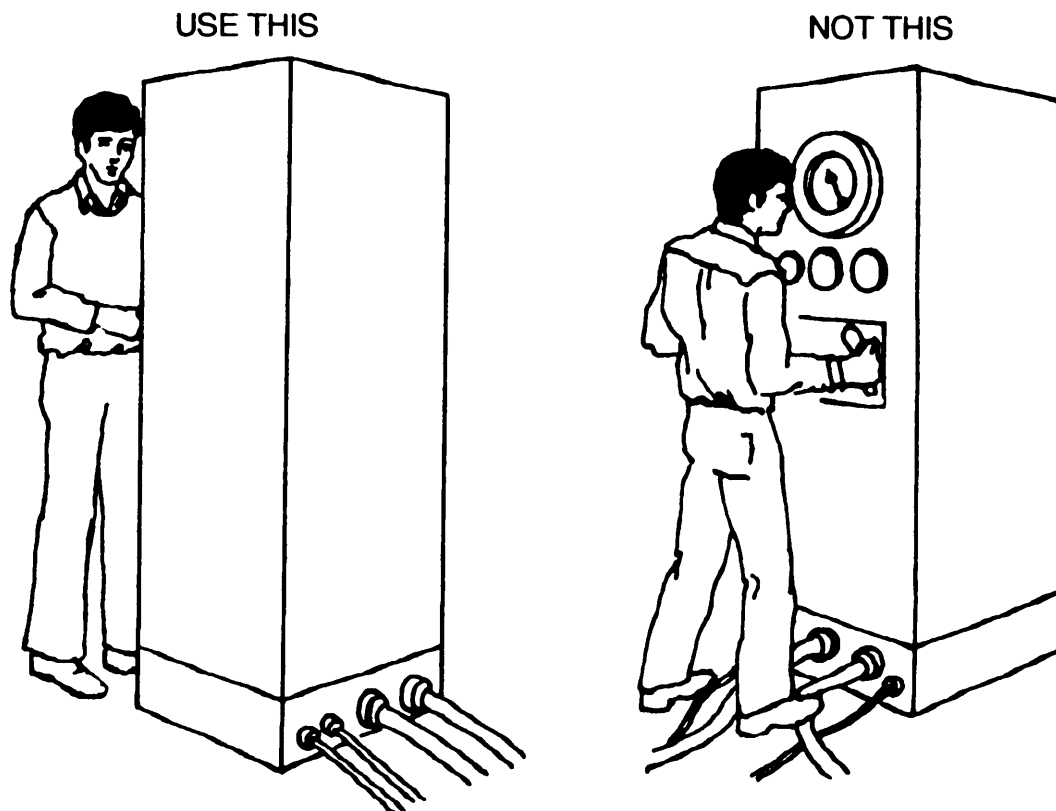

FIGURE 108. Routing cables

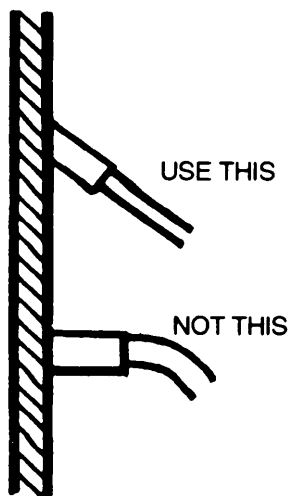

FIGURE 109. Cable connections

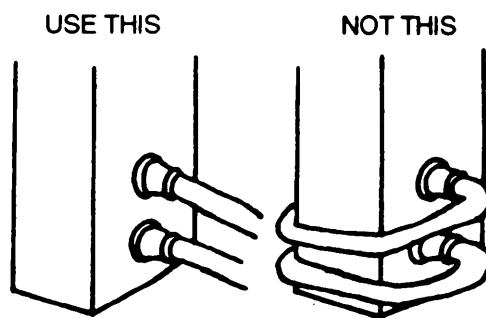

FIGURE 110. Cable bends

MIL-HDBK-759B

- b. Design cables or lines which must be routed through walls or bulkheads for easy installation and removal without the necessity for cutting or compromising the integrity of the system.
- c. Cable routing should avoid close contact with tubes, transformers, or rectifiers so that they will not be damaged by overheating.
- d. Provide guards or other protection for easily damaged conductors such as waveguides, high-frequency cables, or insulated high-voltage cables.
- e. Protect electrical wiring from contact with fluids such as grease, oil, fuel, hydraulic fluid, water, or cleaning solvents. These may damage insulation and result in injury to personnel.
- f. Provide a means for keeping cables and lines off the ground. While permanent lines should never be on the ground, keeping them clear is especially important in areas where ice and snow may cover the lines for long periods, making them inaccessible for maintenance.
- g. Where cable connections are maintained between stationary equipment and sliding chassis or hinged doors, provide service loops to permit movement, such as pulling out a drawer for maintenance without breaking the electrical connection. The service loop should have a return feature to prevent interference when removable chassis are replaced in the cabinet. Figure 111 shows two methods of recoiling the cable.
- h. Provide storage space for long electrical cables which are a part of ground power, service, and test equipment. Often a storage compartment is present, but no easy means is provided for coiling the wire into a shape and size which will permit storage. A simple means is a cable winder, a device around which the cable may be wrapped (see Figure 112). Use a circular spool as a cable winder to prevent bending radii of less than six times the diameter of the cable.
- i. Precautions should be taken to protect the insulation at the ends of cables from moisture. Moisture-proof jacketing, which will withstand the required temperature range and mechanical abuse, should be used.
- j. Provide protective covers for the cable to prevent damage to connectors during periods of non-use. Provisions should be made to secure the protective cover to the cable to avoid misplacement.

5.6.17 Cabling and connectors checklist.

5.6.17.1 General. A checklist summarizing the important maintainability design features relating to cables and connectors is given below. The checklist contains several items which were not discussed separately in the text. These

MIL-HDBK-759B

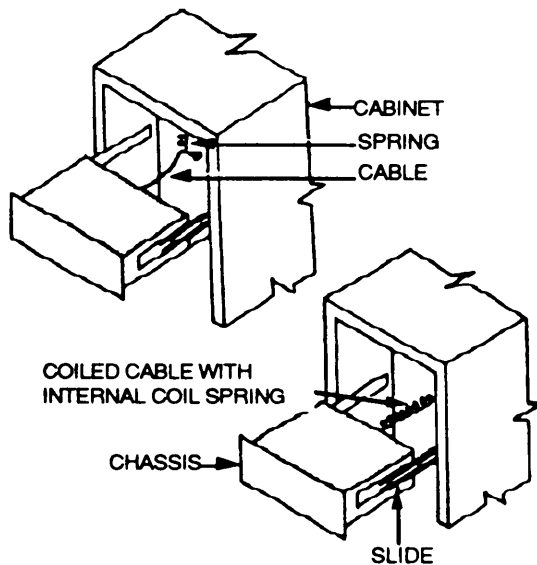

FIGURE 111. Methods for recoiling service loops in sliding chassis

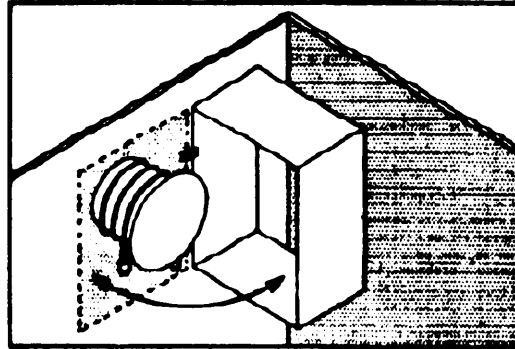

FIGURE 112. Cable winder and cover

items are included here because their necessity in the design is so obvious that they might otherwise be inadvertently overlooked. In using the checklist, if the answer to any question is no, the design should be restudied to ascertain the need for correction.

5.6.17.2 Cables.

- a. Are cables long enough that each functioning unit can be checked in a convenient place?
- b. Can units which are difficult to connect when installed, be moved to convenient positions for connecting and disconnecting?
- c. Are cable harnesses designed for fabrication in a shop as a unit?
- d. Are all cables color coded and are both ends tagged? Can the selected colors be distinguished?
- e. Are cables and lines directly accessible to the technician wherever possible (not under floorboards or behind panels which are difficult to remove)?
- f. Are cables routed so they need not be bent or unbent sharply when being connected or disconnected?
- g. Are cables routed so they cannot be pinched by closing doors or lids or so they will not be stepped on or used as handholds by maintenance personnel?

MIL-HDBK-759B

- h. Are cables or lines attached to units which can be partially removed (chassis on slide racks) and attached so units can be replaced conveniently without damaging the cable or interfering with securing the unit?
- i. Is a 75 mm minimum clearance provided wherever possible between control cables and wiring? Has the designer anticipated potential chafing hazards and provided physical means to prevent chafing?
- j. Is electrical wiring routed away from all lines that carry flammable fluids or oxygen?
- k. Is care taken in design of cable conduits to prevent collection of water or debris which could interfere with operation of a control system (freezing or short circuiting)?
- l. Is the necessity for removing connectors or splicing lines avoided?
- m. Is direct routing through congested areas avoided wherever possible?
- n. Are cable entrances on the fronts of cabinets avoided where it is apparent they could be "bumped" by passing equipment or personnel?
- o. Are cables flexible in Category 7 temperatures?

5.6.17.3 Connectors.

- a. Are adjacent solder connections far enough apart so work on one connection does not compromise the integrity of adjacent connections?
- b. Are connector plugs designed so that pins cannot be damaged (aligning pins extended beyond electrical pins)?
- c. Are self-locking safety catches rather than safety wire provided on connector plugs?
- d. Are connectors designed so that it is physically impossible to reverse connections or terminals in the same or adjacent circuits?
- e. Is the use of special adapters avoided since these are often lost?
- f. Are electrical connectors protected from possible shorting through contact with external objects? Are adequate covers provided on electrical connectors to prevent foreign matter from shorting out the connector or causing damage to the connector threads and pins? Are provisions made to secure the cover to the connector to avoid misplacement during periods of non-use?
- g. Are separate ground connections provided for each voltage regulator so that a single grounding failure does not cause failure of several other systems?

MIL-HDBK-759B

- h. Are quick-disconnect devices used wherever possible to save time and minimize human error which would occur in soldering (fractional-turn, quick-snap action, and press fit)?
- i. Are unkeyed symmetrical arrangements of aligning pins on connectors avoided?
- j. Are electrical terminals plainly marked + (plus) or -(minus), since the caps which are usually marked may be lost?
- k. Do markings on plugs, connectors, and receptacles show proper position of keys for aligning pins for proper insertion position?
- l. Is the use of identical fittings avoided by staggering location, varying lengths, size or shape, or by shape, symbol, or color coding?
- m. On cable-connected removable units, will plug and receptacle disconnect before cable breaks?
- n. Are connectors located for easy accessibility for replacement or repair?
- o. Are U-lugs (spade) used in lieu of O-lugs (ring) where frequent removals are anticipated?
- p. Are auxiliary-equipment connectors used that do not require tools for their operation?
- q. If tools must be used to operate connectors, are only standard tools required?
- r. Do connectors used to connect test equipment to a test point require not more than one full turn?
- s. Can wires be unsoldered and removed without damaging plugs?

5.6.18 Mounting and packaging.

5.6.18.1 General. The majority of parts, items, and assemblies can be located and packaged in a variety of ways and places. The final arrangement should be based on the following factors for ease of maintenance and training.

- a. Accessibility preferences.
- b. Standardization considerations.
- c. Reliability figures and factors, as a basis for access requirements.

MIL-HDBK-759B

- d. Operating stress, vibration, and temperature.
- e. Criteria for built-in test and malfunction circuits or indicators. The peculiar characteristics of each item or module should be chosen with particular reference to:
 - (1) item size, weight, and clearance requirements,
 - (2) item fragility or sensitivity and resultant protection needs,
 - (3) item servicing, adjustment or repair needs and procedures, and
 - (4) tool access and clearance criteria for each item fastener, connector, test or service point.
- f. Specific factors such as critical lead length, weight balance, and heat dissipation, which may hinder personnel in carrying out their tasks.

5.6.18.1.1 Facilitation of maintenance operations. The layout and packaging of components, subassemblies, or assemblies should maximally facilitate the required or expected maintenance operations.

- a. Place-to-place movement of the technician during servicing, checkout, or troubleshooting should be minimized.
- b. The need for the technician to retrace movements or steps during servicing, checkout, or troubleshooting should be minimized.
- c. The number of component or item inputs and outputs should be kept to a minimum.
- d. The equipment should be packaged so the technician has the option of replacing an individual item of a group, or the whole group, in accordance with the maintenance philosophy.
- e. New fastener or bracket assemblies should be provided on spare components where the old ones are likely to be lost or damaged.
- f. Undue sequential assembly that requires sequential disassembly to accomplish maintenance should be avoided.
- g. Sliding racks, or hinged assemblies, should be used to allow maximum accessibility.
- h. Organization should be according to maintenance specialties so that maintenance performed by one specialist does not require removal or handling of equipment maintained by another specialist, particularly where such equipment is of a critical nature or its maintenance requires highly specialized skills.

MIL-HDBK-759B

5.6.18.2 Mounting. Parts, subassemblies, and assemblies should be mounted so that only interconnecting wire and structural members are permanently attached to units; all other fixtures should be removable for ease of maintenance. Fixtures which are built into the chassis should be either strong enough to withstand usage by personnel over the life of the system or are removable. Mounting should be compatible with the size and weight of the part to prevent lead breakage or similar damage from fatigue under personnel handling stress.

5.6.18.3 Straps and brackets. Straps and brackets should be thick or rounded enough so that they have no sharp" edges. They also should be twist or push-to-lock mounting type for small components; such brackets should be designed so locking studs are visible when the component is in place and locking screws or dimples are provided, as necessary, to ensure security of the mount. Straps and brackets should be used as necessary for tying down large components and supporting items mounted on the underside of assemblies. They also should be used instead of cantilever brackets for mounting parts and as necessary to prevent the mounted item from sliding or jumping out of position. "U" straps should be used to "tie down" components, not to secure or support them.

5.6.18.4 Guides and guide pins.

5.6.18.4.1 General. Supports, guides, and guide pins should be provided as necessary to assist handling, aligning, and positioning units. Their design should prevent mismatching or misalignment during installation or replacement.

5.6.18.4.2 Bottom-mounted aligning pins. Bottom-mounted aligning pins should be used for components which are light enough to be lifted and positioned easily such as those weighing less than 9 kg.

5.6.18.4.3 Side-aligning devices. Side-aligning devices or brackets should be used for heavy components so the components can be slid rather than lifted into and out of place.

5.6.18.5 Shock mounts. Shock mounts should be used, as necessary, to eliminate vibrational fluctuations in displays and markings which will cause error in operator reading as well as to protect fragile or vibration-sensitive components and instruments. Shock mounts also control sources of high or dangerous noise and vibration for effective human performance.

5.6.18.6 Coding, marking and labeling. The rapidity, accuracy, and ease of maintenance, particularly troubleshooting, are proportional to the amount of color coding, marking, and labeling employed. These are the most direct links between the designer and the technician and should be used as fully as possible to explain the arrangement, function of, and relationship among items. There are no hard and fast rules for coding and labeling as a function or part of packaging; the effectiveness of such efforts depends largely on the care and ingenuity of the designer. Codes and labels used on and within equipment packages should be:

MIL-HDBK-759B

- a. in accordance with the principles for coding and labeling,
- b. in keeping with test and service-point coding and labeling,
- c. consistently and unambiguously used throughout the system,
- d. of such a nature as to be easily read and interpreted,
- e. durable enough to withstand expected wear and environmental conditions,
- f. coordinated and compatible with codes and labels on related test and service equipment, other coding and labeling within the system, and related job aids, instructions, handbooks and manuals.

5.6.18.6.1 Identification. For identification purposes, codes and labels should be provided on, and within, the packaging arrangement as necessary to:

- a. outline and identify functional groups of equipment,
- b. identify each item or part by name or common symbol,
- c. identify each test or service-point, and the sequence in which it is used,
- d. identify the value and tolerance of parts such as resistors (directly rather than in color code where possible),
- e. indicate the direction of current or fluid flow, to aid systematic elimination of possibilities when troubleshooting without cross-reference to schematics,
- f. indicate "maintenance highways" to guide the technician through routine processes,
- g. indicate the weight of units over 16.8 kg,
- h. point out warning and caution areas,
- i. present an outline procedure not made obvious by design and to supply whatever information is necessary for troubleshooting and maintenance, and
- j. allow the presentation or recording of historic data where practical, particularly to display periodic readings at test points, to allow development of trends where these are fundamental to maintenance decisions, and permit recording of replacement dates, or other data necessary to replenishment criteria or preventive maintenance.

MIL-HDBK-759B

5.6.18.7 Packaging and mounting. Assemblies, modules, and parts should be packaged and mounted in accordance with the principles listed below.

- a. Adequate tool access and wrenching space is provided around fasteners.
- b. Adequate space is provided for use of test probes and other service or test equipment.
- c. Components to be serviced or repaired in position are at the most favorable working level (between hip and shoulder level).
- d. Maintenance required on a given unit or component can be performed with the unit or component in place, where possible, and without disconnection, disassembly, or removal of other items.
- e. All replaceable items, particularly disposable modules, are removable without removal or disassembly of other items or units, by opening a minimum number of covers, cases, and panels, without hindrance from structural members or other parts, and along a straight or slightly curved line, rather than through an angle or more devious course.
- f. All heavy, large, or awkward units are located so they may be slid out or pulled out rather than lifted out, do not prevent access to other removable items, and are mounted on sliding drawers and racks wherever practicable.
- g. When it is necessary to place one unit behind or under another, the unit requiring the most frequent maintenance is most accessible.
- h. All chassis are completely removable from the enclosure with minimum effort and disassembly.
- i. Structural members of items, chassis, or enclosures do not prevent access to removable items, their connectors, or fasteners.
- j. Removal and replacement require minimum tools and equipment, and only common hand tools where practicable.
- k. Rapid and easy removal and replacement can be accomplished by one person, two persons, or handling equipment, in that order of preference.
- l. Irregular, fragile, or awkward extensions, such as cables and hoses are easily removable before the unit is handled. (Such protrusions are easily damaged by personnel and make handling difficult.)
- m. Handling and carrying can be done efficiently by one person:
 - (1) Removable items should weigh less than 16.8 kg.
 - (2) Difficult to reach items should weigh less than 11.3 kg.

MIL-HDBK-759B

- n. Items over 16.8 kg are designed for two-person handling.
- o. Hoist lugs are provided for assemblies over 40.8 kg.

5.6.18.8 Personnel safety. Items should be located, packaged, mounted, and shielded so that access to them, adjacent items, or associated fasteners can be achieved without danger to personnel from electrical charge, heat, sharp edges, points, moving parts, chemical contamination, or other hazards. Design, packaging, and mounting should be according to the considerations listed below.

- a. For personnel protection, commonly worked on parts, fasteners, service or test points should not be located near exposed terminals or moving parts.
- b. Guards or shields should be provided to prevent personnel from coming into contact with dangerous moving parts or potential injury.
- c. Ventilation holes in equipment should be located and made small enough to prevent insertion of fingers and tools into hazardous areas.
- d. Tool guides should be provided to allow safe manipulation of points adjacent to high voltages or other hazards.
- e. Capacitors, exhaust pipes, or other parts which retain heat or electrical potential after the equipment is turned off, should be located or shielded so personnel cannot contact them accidentally.

5.6.18.9 Removable pins, caps, and covers. Small removable pins, caps, and covers should be attached to prevent loss or damage. Vital, fragile, sensitive, or easily damaged components should be located, arranged, and shielded so they will not be used for handholds, footholds or rests, or damaged by flying particles, loose objects, or movement of personnel or tools during maintenance.

5.6.18.10 Blind mounting. Where blind mounting is required, the inaccessible side should be secured with mounts which allow exceptionally easy mating and do not require access to friction lugs, or tongue-and-groove fittings.

5.6.18.11 Fold-out construction. Fold-out construction should be used for every feasible (see Figure 113); the parts and wiring should be positioned to prevent damage to them when the assembly is opened or closed.

MIL-HDBK-759B

5.6.18.12 Braces. Braces, or similar items, should be provided to hold hinged assemblies in the "out" position while they are being repaired (see Figure 114). Rests or stands should be provided to prevent damage to delicate parts. If feasible, the rests or stands should be a part of the basic chassis as shown on Figure 115.

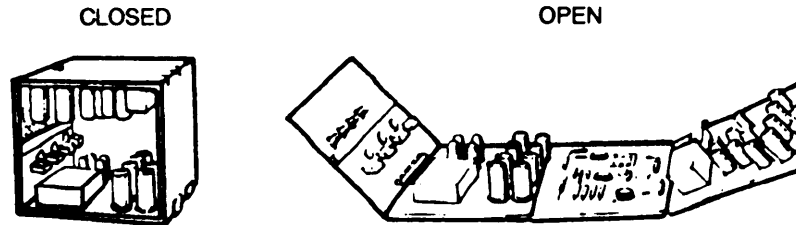

FIGURE 113. Fold-out construction for electronic chassis

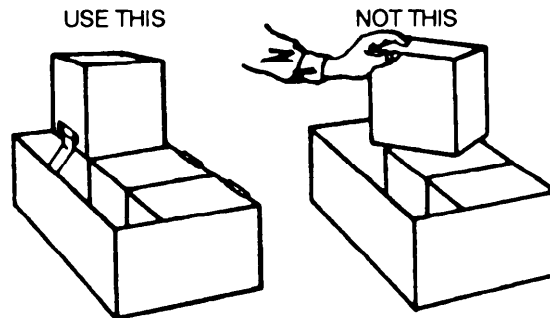

FIGURE 114. Hinged assemblies

MIL-HDBK-759B

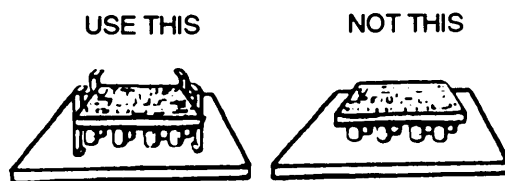

FIGURE 115. Use of maintenance stands

5.6.18.13 Spring clamps. Use spring clamps to mount tubing, pipes, or wiring which may require frequent removal and replacement (see Figure 116). For overhead mounting, use a spring clamp similar to that used for floor mounting, but provide a hinged locking latch over the open side of the clamp to prevent accidents.

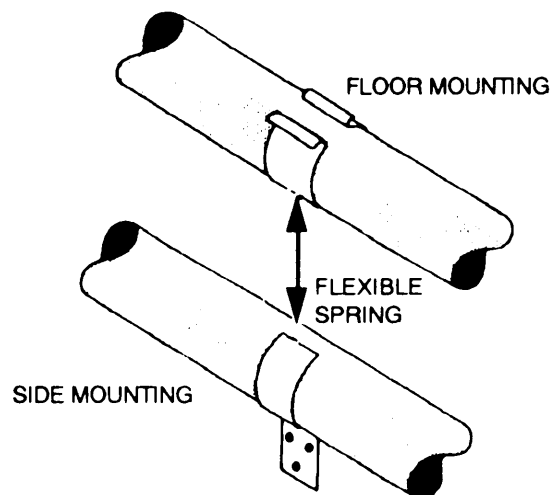

FIGURE 116. Use of spring clamps

5.6.18.14 Other considerations.

- a. Adjustment and alignment devices should be mounted so they cannot be inadvertently actuated by the technician.
- b. Mountings of components, modules, and parts should be designed to prevent their being inadvertently reversed, mismatched, or misaligned during installation or replacement.
- c. While components of the same form, function, and value should be completely interchangeable throughout the system, components of the same or similar

MIL-HDBK-759B

form, but of different functional properties, should be readily identifiable, distinguishable, and not physically interchangeable.

- d. Hinged bars are useful for tying down and permitting access to a number of small components at one time.

5.6.19 Replaceable units.

5.6.19.1 General. There are two primary reasons for designing electronic equipment with relatively small, removable or replaceable units. Constructing electronic equipment with easily removable assemblies, subassemblies, and components permits the division of maintenance responsibility. This design permits rapid corrective maintenance at the user level. When equipment is built with removable units, it is easier to work on malfunctioning parts.

5.6.19.2 Design recommendations.

- a. Replaceable components should be designed so they cannot be installed in the wrong way. Also, if two parts are physically interchangeable, they should be functionally interchangeable. Designs, mockups, and manufacturing processes should be continually reviewed to identify and correct, or compensate for, all potential sources of such errors.
- b. Tapered alignment pins, quick-disconnect fasteners, and other similar devices should be able to facilitate removal and replacement of components.
- c. Mounting brackets and surfaces should be designed so that mounting bolts and fasteners can be placed on a surface adjacent to the technician's workspace. Guides and guide pins should be provided for alignment of units on mountings (see Figure 117).
- d. Where possible, units should be designed so they are removable along a straight, or slightly curved line, rather than through an angle (see Figure 118).

MIL-HDBK-759B

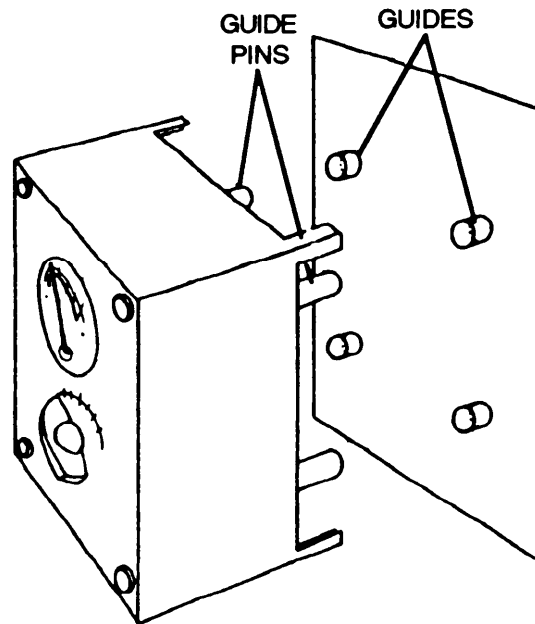

FIGURE 117. Alignment guides and guide pins



FIGURE 118. Equipment removal

- e. Mounting brackets should be designed so that the component can be installed only in the correct position. Where space permits, side-alignment brackets which permit installation in only one position should be provided (see Figure 119).

MIL-HDBK-759B



FIGURE 119. Use of side-alignment brackets

- f . Bottom-mounted aligning pins should be used for components which are light enough to be lifted easily. Such aligning pins are not desirable for heavy components because they require a lifting process for aligning the component. Side-aligning devices, similar to the one shown in Figure 119, are more desirable for heavy components because the component can be slid into place.
- g. Symmetrical components should be coded, labeled, or keyed to indicate the proper orientation for mounting or installation.
- h. Opening more than one access panel to remove any single unit should not be required.
- i. Components should be positioned so that the technician does not have to reach too far for heavy units.
- j. For components that are heavy or relatively inaccessible, slide-out racks should be provided. When using roll-out mounting racks, limit stops should be provided to prevent dropping the components.
- k. Units should be designed for easy connection to each other and to the housing in which they are installed.
- l. Electronic and electrical units should be designed with plug-in rather than solder connections.
- m. When using AN connectors, the quick-disconnect type (see Figure 120) should be specified.

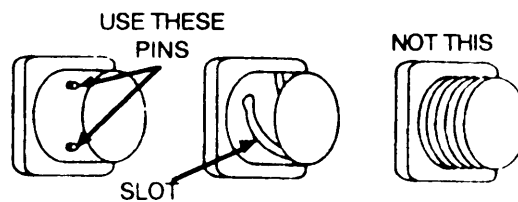

FIGURE 120. Types of AN connectors

MIL-HDBK-759B

- n. Incorrect assembly should be made difficult by using different sizes, or completely different types of connectors. Where incorrect assembly is possible, use coding techniques such as different color, size, and shape.
- o. Connectors requiring no tools (or only common hand tools) and with only a fraction of a turn or quick-snap action should be used.
- p. Mounting bolts, screws, and fasteners that can be easily removed and replaced with minimum chance for error should be provided. Use captive bolts and nuts to prevent dropping small items into the equipment.
- q. Small removable parts such as pins, caps, and covers should be attached to the main body of the equipment by small chains or other suitable means to prevent their loss. Because some retainers tend to break apart, especially when kinked, care should be exercised in the selection of suitable retainers to ensure that they meet performance requirements.
- r. Lock washers or other restraining measures should be used to prevent bolts and nuts from vibrating loose. Safety wire is not generally recommended, but if it must be used, a simple means of attaching it should be provided.
- s. The weight of components should be kept under 13.6 kg where possible.
- t. Adequate handles on all units weighing more than 4.5 kg should be provided. Handles should be provided for units weighing less than 4.5 kg if they might otherwise be difficult to grasp, remove, or hold.

5.6.20 Location of individual components.

5.6.20.1 Location and layout. Units should be located so no other equipment has to be removed to gain access to them. All components should be laid out so they are accessible with the emphasis for easy access placed on items that require frequent inspection and maintenance. Components maintained by the same technician should be grouped together so that only a minimum of moving from position to position is necessary during system checking. Components that require frequent visual inspection, check points, adjustment points, cable-end connectors, and labels should be located in positions that can be seen easily. All components should be located to minimize the possibility of equipment damage or personnel injury.

5.6.20.1.1 Equipment and personnel safety.

5.6.20.1.1.1 Protection from fluids. Components should be placed in positions where oil and other fluids are not likely to fall on them.

MIL-HDBK-759B

5.6.20.1.1.2 High temperature guards. High-temperature parts should be guarded or located so personnel will not contact them during operation or maintenance. Heat-producing equipment should be arranged and shielded so discomfort to personnel is avoided.

5.6.20.1.1.3 Enclosure of high-current devices. High-current switching devices should be enclosed to protect personnel. Components that retain electrical potential after the equipment is turned off should be equipped with bleeder networks. Internal controls should not be located close to dangerous voltages.

5.6.20.1.2 Hinge-mounted units. Small hinge-mounted units, which require access to the back, should be free to open their full distance and remain open without being held (see Figure 121).

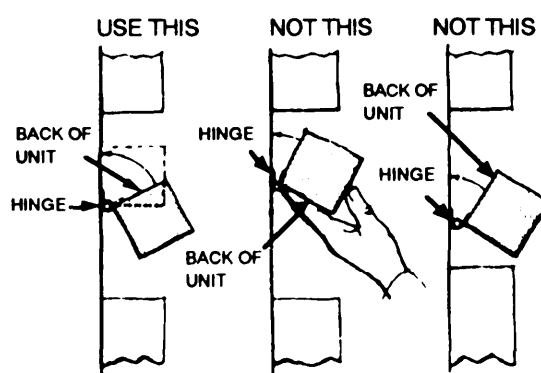

FIGURE 121. Hinged units

5.6.20.1.3 Stacking units. Units should not be stacked. If stacking is necessary because of space limitations, place the unit requiring the least frequent access in the back or on the bottom.

5.6.20.1.4 Frames and structural members. Frames and structural members should not interfere with maintenance and operational personnel reaching components they have to maintain, inspect, or operate (see Figure 122).

5.6.20.1.5 Tubes. Tubes should be replaceable without interference from resistors, capacitors, or wiring and without removing assemblies or subassemblies. Miniature tube sockets should be oriented with gaps facing in one direction to facilitate replacing tubes (see Figure 123). When tubes are replaced through narrow openings, an external indication of the position for pin insertion should be provided.

MIL-HDBK-759B

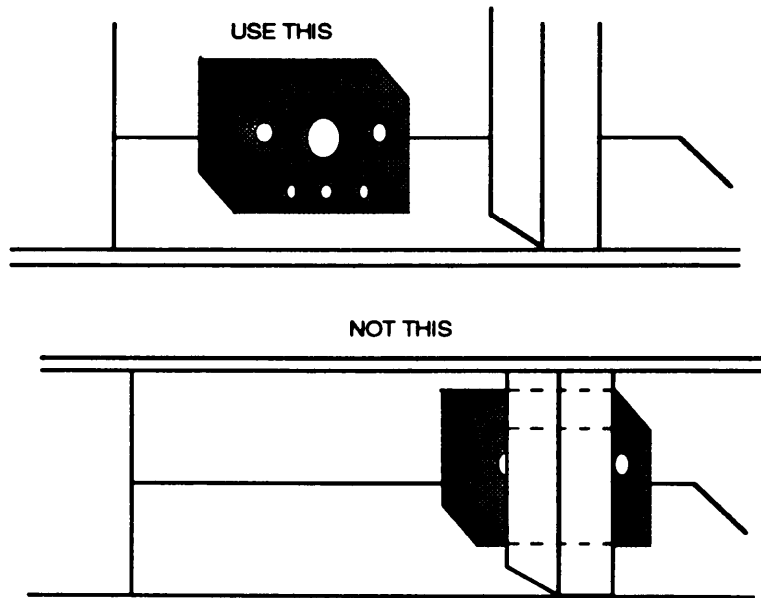

FIGURE 122. Component placement

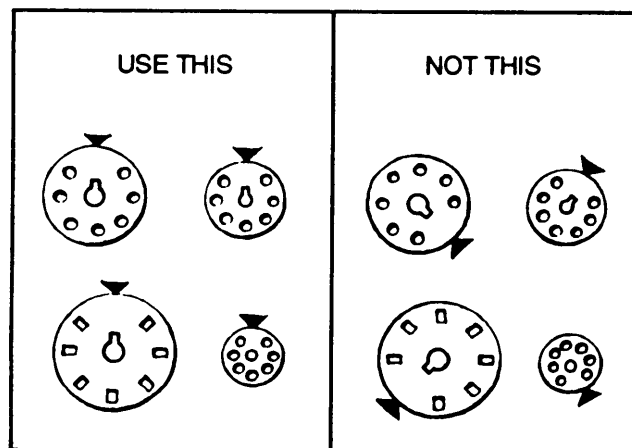

FIGURE 123. Tube sockets orientation

MIL-HDBK-759B

5.6.20.1.6 Fuses. Fuses should be located so they can be seen and replaced without tools or removing other parts or subassemblies.

5.6.21 Equipment units checklist. The following checklist summarizes some of the important features to be considered in the design of equipment units. The checklist contains several items which were not discussed separately in the text. These items are included here because their necessity in design is so obvious that they might otherwise be inadvertently overlooked. In using the checklist, if the answer to any question is no, the design should be restudied to ascertain the need for correction.

- a. Are plug-in components used where feasible?
- b. Is wrong installation of unit prevented by virtue of size, shape or configuration?
- c. Are modules and mounting plates labeled?
- d. Are guides used for module installation?
- e. Are means provided for pulling out drawers and slide-out racks without breaking electrical connections when internal in-service adjustments are required?
- f. Are units and assemblies mounted so that replacing one does not require removal of others?
- g. Are parts mounted on a single plane, not stacked one on another?
- h. Are parts mounted on one side of a surface with associated wiring on the other side?
- i. Are easily damaged components mounted or guarded so they will be protected?
- j. Are all replaceable parts accessible by fold-out construction or other special techniques when necessary?
- k. When fold-out construction is employed, are parts and wiring positioned to prevent damage by opening and closing?
- l. Are braces provided to hold hinged assemblies in the 'out' position while being worked on?
- m. Are parts which retain heat or electrical potential after the equipment is turned off located so that the technician is not likely to touch them while replacing commonly malfunctioning parts such as tubes?
- n. When screwdriver adjustments should be made by touch, are screws mounted vertically so that the screwdriver will not fall out of the slot?

MIL-HDBK-759B

- o. When necessary, are internal displays illuminated?
- p. Are internal controls (switches, adjustment screws) located away from dangerous voltages?
- q. Are screwdriver guides provided on adjustments which are located near high voltages?
- r. Are parts located so that other large parts (such as indicator and magnetron tubes), that are difficult to remove, do not block access to them?
- s. Are parts, assemblies, and components placed so there is sufficient space to use test probes, soldering irons, and other tools without difficulty?
- t. Are parts, assemblies, and components placed so that structural members of units do not prevent access to them?
- u. Are all throwaway items made accessible without removal of other items?
- v. Are units designed so that it is unnecessary to remove an assembly from a major component to troubleshoot that assembly?
- w. Is equipment laid out so the technician will not have to retrace movements during checking routines?
- x. Are all miniature tube sockets oriented with the gaps facing one direction?
- y. When tubes should be replaced through small access openings, is there an external indication of the position for pin insertion?
- z. Are all fuses located so they can be seen and replaced without removal of any other items?
- aa. Are fuse assemblies designed and placed so that tools are not required to replace fuses?
- bb. Are removable units

5.6.22 Test and service points.

5.6.22.1 General. In order to make testing and servicing as simple as possible, the recommendations of this section should be considered by the designer.

MIL-HDBK-759B

5.6.22.1.1 Arrangement of test points. Test points should be arranged on a panel of other surfaces according to the criteria listed, in order of priority.

- a. The type of test equipment used at each point.
- b. The type of connector used and the clearances it requires.
- c. The function to which each point is related.
- d. The test routines in which each point will be used.
- e. The order in which each will be used.

5.6.22.1.2 Design considerations. In order for the operator to best use the test and service points on equipment, the following criteria are recommended for consideration by the designer. These test and service points should be provided, designed, and located:

- a. According to the frequency and time requirements of use.
- b. So that there will be a minimum of disassembly or removal of other equipment or items.
- c. On surfaces or behind accesses which may be easily reached or readily operated when the equipment is fully assembled and installed.
- d. To be clearly distinguishable from each other (where necessary use color coding and labeling).
- e. So that test points and their associated labels and controls face the technician.
- f. So that adequate clearance is provided between connectors, probes, and controls for easy grasping and manipulation. Minimum clearances recommended are 19 mm when only finger control is required, and 75 mm when the gloved hand should be used.
- g. So they offer positive indication, by calibration, labeling or other features, of the direction, degree, and effect of the adjustment.
- h. With guards and shields to protect personnel and test or service equipment, particularly if the equipment must be serviced while operating.
- i. At a central panel or location, or at a series of functionally autonomous panels and locations.
- j. To avoid locating a single test or service point in an isolated position; such points are most likely to be overlooked or neglected.

MIL-HDBK-759B

- k. With lead tubes, wires, or extended fittings to bring hard-to-reach test and service points to an accessible area.
- 1. To overcome accessibility deficiencies resulting from critical lead lengths and similar constraints.
- m. With windows to internal items requiring frequent visual inspections, such as gauges and indicators.
- n. **With tool** guides and other design features to facilitate operation of test or service points which require blind operation.
- o. Within easy functional reach or seeing distance of related or corresponding controls, displays, fittings, and switches.
- p. Away from dangerous electrical, mechanical, or other hazards. A hand's width (115 mm) separation should be provided from the nearest hazard along with guards and shields, as necessary to prevent injury.
- q. So they are not concealed or obstructed by the hull, turret, brackets, or other items.

5.6.22.1.3 Adjustment controls. Where adjustment controls are associated with test and service points, they should be designed and positioned as listed below.

- a. They are located on a single panel or face of the equipment, or on a minimum number of functionally independent panels.
- b. They are capable of being quickly returned to the original settings, to minimize realignment time if they are inadvertently moved.
- c. Adjustments are independent of each other whenever possible.
- d. Those that require sequential adjustment are located in the proper sequence and marked as necessary to designate the order of adjustment.
- e. Adjustment procedures are clear and straightforward and do not require conversion or transformation of related test values.
- f. Knobs are used in preference to screwdriver adjustments; the latter are generally unsatisfactory from the standpoint of easy manipulation and the requirement for tools.

MIL-HDBK-759B

5.6.22.1.3.1 Types of adjustment to avoid. The following types of adjustment are to be avoided, except where their use will considerably simplify the design or use of the equipment.

- a. Extremely sensitive adjustments.
- b. "System adjustments," such as where components cannot be replaced without recalibrating the whole system.
- c. Harmonizing or "mop-up" adjustments, such as those that require "A" or "B" to be readjusted after A, B, and C have been adjusted in sequence.

5.6.22.1.4 Procedures to test adequacy of test points arrangement. The following arrangements are intended to help the designer evaluate the adequacy of the plan or test point arrangement.

- a. A built-in test unit, built in as part of the installation, is most desirable for efficient maintenance and troubleshooting. For example, if voltages and wave shapes should be checked, the test unit might consist of a meter, an oscilloscope, and a rotary switch for selecting circuits, as shown in Figure 124A. The meter and oscilloscope should have fixed, preset circuits so that the meter always reads center scale and the oscilloscope needs no adjustment. Either an in-tolerance meter reading or an in-tolerance waveform on the oscilloscope should be coded for each position of the rotary switch. If more test points are needed than can be handled by a single switch, multiple switches could be used.
- b. A partially built-in test unit is sometimes preferred because some oscilloscopes are large, heavy, and expensive. It might not be practical to design a test unit such as that recommended in step (a) for each major component of a system. An acceptable compromise is to mount a center-reading meter on each major component that can be checked by meter and then provide a set of test jacks as an outlet for signals requiring an oscilloscope, as shown in Figure 124B. The selector switch and circuits for this arrangement should be designed as before.
- c. A portable test unit may be required if neither of the two previous arrangements is practicable because of space or weight limitations. An integrated portable test unit resembling the built-in unit can be designed, as shown in Figure 124C. A single multi-prong contact, on the end of a cable, can be used to attach the test unit.
- d. If, for some reason, none of the alternatives described above is practicable, a built-in test panel should be provided on the equipment, as shown in Figure 124D. With this arrangement, the outputs of each test point should be designed for checking with standard test equipment, and the points should be planned to provide a miniature block diagram of the system, with each block representing a line replaceable unit. Overlays for the test panel should direct

MIL-HDBK-759B

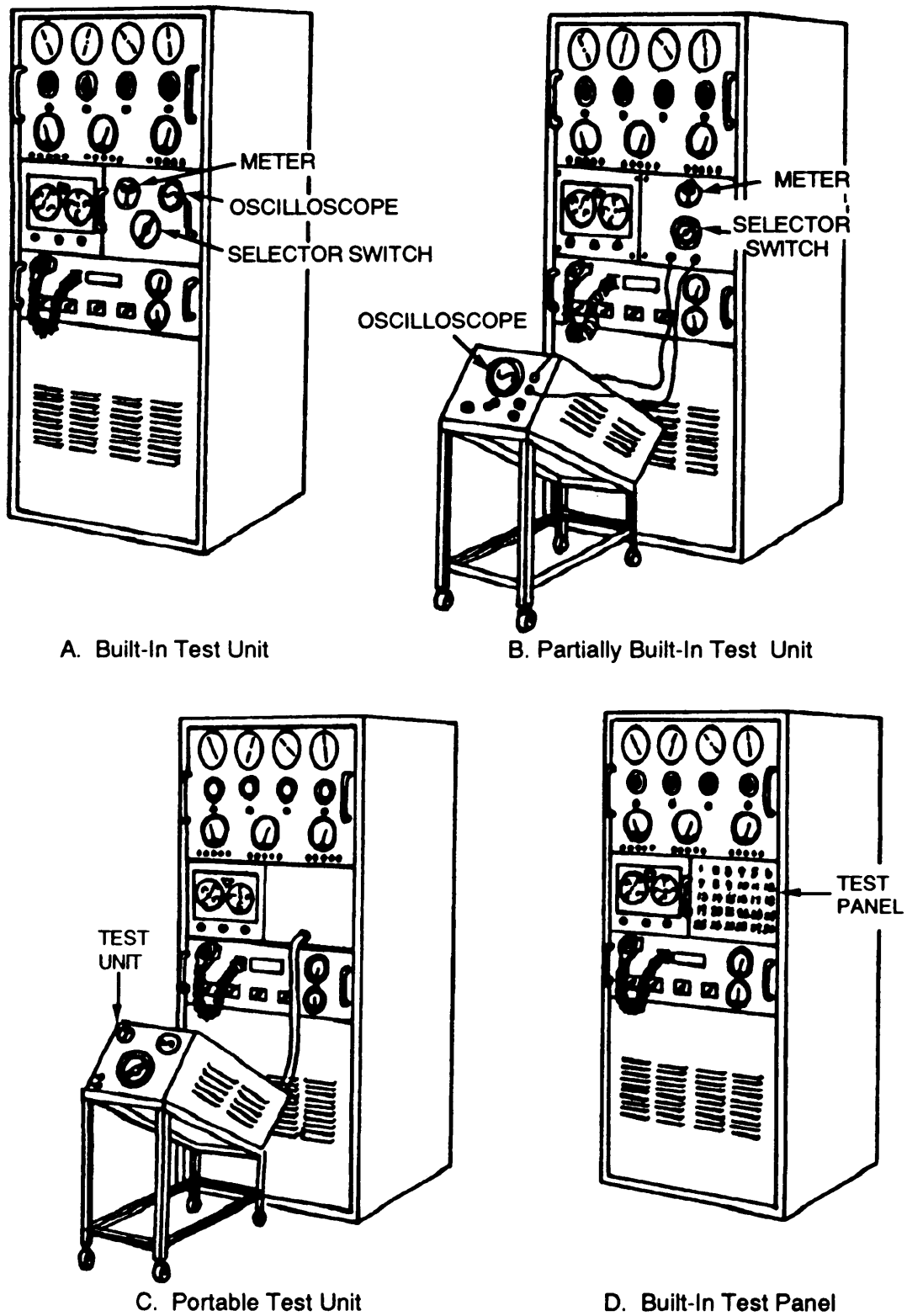

A. Built-In Test Unit

B. Partially Built-In Test Unit

C. Portable Test Unit

D. Built-In Test Panel

FIGURE 124. Alternate methods for grouping test points

MIL-HDBK-759B

the technician to test points to check and the order in which to check them. in-tolerance signals should be shown on the overlays, and test points should be coded on the panel, with full instructions provided in the maintenance manual, in the event the overlay is lost.

- e. Test points for the input and output on each replaceable unit may be provided if none of these arrangements is practicable. If possible, mount components on one side of the board or chassis and wiring on the other side (see Figure 125). Even if the wiring is mounted on the same side as the parts, test leads should be brought through to the back. An advantage in having test points on the back is that full identifying information for each test point can be marked on the back without being obscured by parts.

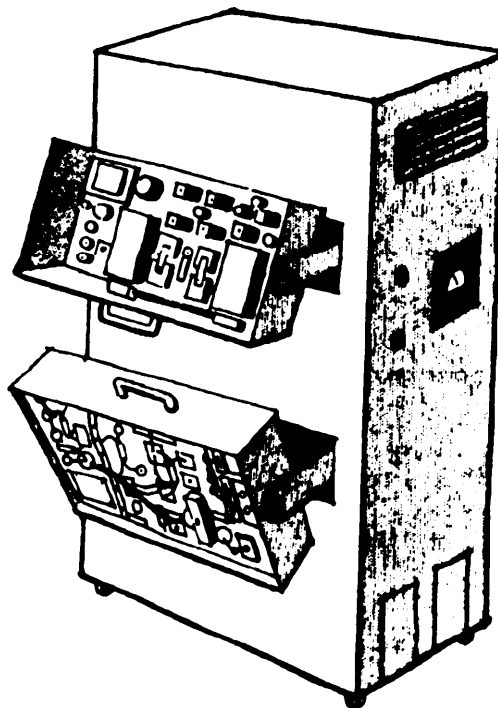

FIGURE 125. Test points on replaceable units

5.6.22.1.5 Labeling test points. Label each test point with a number, letter or other symbol that identifies it in the maintenance instructions. If possible, label each test point with the in-tolerance signal and the tolerance limits of the signal that should be measured. If possible include the name of the unit in the label. Consider color coding test points so they can be located easily. Use phosphorescent or chemoluminescent markings on test points, selector switches and meters that might have to be read in very low ambient illumination.

MIL-HDBK-759B

5.6.22.1.6 Other considerations. The following topics represent areas not covered in the above paragraphs but are still important design considerations.

- a. Templates or overlays should be provided where they will expedite the use of different test procedures which use the same set of test points.
- b. The maximum use of color codes, guidelines, symbols, and labels should be made to facilitate following logical test routines among the test points.
- c. Distinctively different connectors or fittings should be provided for each type of test or service equipment, probe, grease, or oil to minimize the likelihood of error or misuse.
- d. Requirements for separate funnels, strainers, adaptors and other accessories should be avoided. Where practical, these should be built into the equipment or service equipment, so they need not be handled separately.
- e. Test points should be combined, where feasible, into clusters for multi-pronged connectors, particularly where similar clusters occur frequently.
- f. Lubrication points should be provided to avoid disassembly of equipment; but if such points are not feasible, easy access should be provided for direct lubrication.

5.6.22.2 Test points checklist. The following checklist summarizes some of the important features pertaining to the design of test points. The checklist contains several items which were not discussed separately in the text. These items are included here because their necessity in the design is so obvious that they might otherwise be inadvertently overlooked. In using the checklist, if the answer to any question is no, the design should be restudied to ascertain the need for correction.

- a. Are test points located on the front panel wherever possible?
- b. Is accessibility of external test points assured under conditions of use?
- c. Are test points grouped for accessibility and convenient sequential arrangement of testing?
- d. Is each test point labeled with name or symbol appropriate to that point?
- e. Is each test point labeled with the in-tolerance signal or limits which should be measured?
- f. Are test points labeled with the designation of what output is available?
- g. Are all test points color coded with distinctive colors?
- h. Are test points provided in accordance with the system test plan?

MIL-HDBK-759B

- i. Do test-lead connectors require no more than a fraction of a turn to connect?
- j. Are test points located close to controls and displays with which they are associated?
- k. Is the test point used in an adjustment procedure associated with only one adjustment control?
- l. Are means provided for an unambiguous signal indication at a test point when the associated control has been moved?
- m. Are test points located so the technician operating the associated controls can read the signals on the display?
- n. Are test points provided for a direct check of all replaceable parts?
- o. Are fan-out cables in junction boxes used for checking if standard test points are not provided?
- p. Are test points planned for compatibility with the maintenance skill levels involved and not randomly located?
- q. Are test points coded or cross-referenced with the associated units to indicate the location of faulty circuits?
- r. Are test points provided to reduce the number of steps required (split-half isolation of trouble, automatic self-check sequencing, minimizing of step retracing or multiple concurrent tests)?
- s. Are test points located so as to reduce hunting time (near main access openings, in groups, properly labeled, near primary surface to be observed from working position)?
- t. Are test points which require test-probe retention designed so that the technician will not have to hold the probe?
- u. Are built-in test features provided wherever standard portable test equipment cannot be used?
- v. Can the technician gain access to routine check points without removing the units or module or removing a cover from the cabinet?
- w. Are test points adequately protected, illuminated, and accessible?
- x. Are routine test points available to the technician without removing the chassis from the cabinet?

MIL-HDBK-759B

5.6.22.3 Test equipment. Regardless of the engineering sophistication of the testing device, unless the technician recognizes it as being useful, reliable, and operable, the technician will avoid using it, and the design will be, for all practicable purposes, wasted. To design for usability, the designer should consider the statements listed below.

- a. Technicians are trained to use complex devices, but they occasionally forget what they learn.
- b. Technicians avoid using devices they do not understand or find difficult to operate.
- c. Supervisors hesitate to let technicians use expensive, complex equipment when the operation of the equipment is not simple or self-evident.
- d. When test equipment is overly complex and difficult to operate, the technician:
 - (1) should spend considerable time and effort learning to operate it,
 - (2) tends to make errors in usage,
 - (3) can learn to operate only a small number of devices well, and
 - (4) finds that habits developed with one device interfere with learning to use or operate another device.
- e. Military testers, which are drab, unattractive and apparently rugged, actually get rougher treatment than those which look fragile or have eye-appeal. Therefore, testers should be designed to look no tougher than they are, and to compensate for the rough treatment they are likely to receive.

5.6.22.3.1 Common complaints about available test devices. The following list provides common complaints about available test devices or reasons for not using them. Each of these reasons is a result of inadequate consideration of the user during design and should be avoided in the design of new devices.

- a. The device was too clumsy, heavy, or awkward to carry to the job.
- b. There were an unnecessarily large number of different test devices.
- c. Procedures and displays were inconsistent from device to device.
- d. There was confusion as to the accuracy, operation, or purpose of the device.
- e. The device was inaccurate, unreliable, or too often out-of-tolerance.
- f. Calibration was too difficult and kept the device out of use too often.

MIL-HDBK-759B

- g. The device was not compatible with the tested equipment. For example, connectors were too loose or too hard to reach, leads were not long enough, or workspace was too small to use the device.

5.6.22.3.2 Maintenance environment. To best utilize an individual with respect to test equipment, the maintenance environment in which testing is to be done should be considered, particularly with regard to:

- a. the environmental extremes to be withstood by the human operating the device,
- b. maintenance procedures and policies the users will have to follow,
- c. symbols and codes commonly employed by, or familiar to, the user,
- d. methods of information presentation, data collection, or maintenance feedback by, or familiar to, the user,
- e. purposes for which the tester will be employed, in terms of what the technician should do with the information obtained from the tester,
- f. tasks involved in using the tester, from maintenance task assignment to return of the tester to storage, and
- g. the manner of transporting the tester from storage to place of application, including how far it should be transported, and by what means as well as the clothing or other encumbrances the technician will be wearing.

5.6.22.3.3 Instructions. To facilitate understanding and increase operator efficiency, instructions should be provided in the manner described below.

- a. On the face of the tester, in the lid, or in a special compartment.
- b. In a step-by-step fashion, numbered, or lettered in serial order.
- c. In easy view while the device is being operated.
- d. As complete and detailed as required, but strictly job oriented.
- e. In simple language, avoiding uncommon terms or symbols.
- f. Large enough to be clearly and easily read in poor light.
- g. Emphasize critical material by larger type or color coding.
- h. Have a distinguishable title where more than one instruction list is required (color coding should be considered also).
- i. As a reminder that the device should be calibrated, especially if calibration is required before each use or change in use.

MIL-HDBK-759B

- j. As a reminder to ensure that the test equipment will be turned off when testing is completed.

5.6.22.3.4 Displays. Whenever more than one scale must be in the technician's view, each should be clearly differentiated from the other by labeling and color coding to their respective control positions. Exact values should be presented on test equipment displays rather than indications which require multiplication or other transformation of display values.

5.6.22.3.5 Switches. Selector switches should be used on test equipment instead of a number of plug-in connections. Devices, such as circuit breakers and fuses, should be employed to safeguard against damage if the wrong switch or jack position is used.

5.6.22.3.6 Handles. See 5.6.13.

5.6.22.3.7 Design of portable test equipment.

- a. Portable test equipment may be necessary when the number, or complexity, of functions to be tested would make hand-held testers too heavy or bulky.
- b. Portable test equipment may be necessary when a number of pieces of equipment must be tested and are physically separated.
- c. Portable test equipment may be necessary when the equipment to be tested will not be located at a permanent testing installation.
- d. Portable test equipment should be of medium size and weight and be approximately cubic in shape.
- e. Rectangular or square shapes are recommended for easy storage. If possible, their dimensions should fit relay racks for transportation in shop vans in the field.
- f. Storage space for test equipment instructions should be provided on, or within, the test equipment.
- g. Stands or casters should be provided for devices weighing more than 13.6 kg.
- h. Wheels, casters, or hoist-lifting should be provided for devices weighing more than 40.8 kg.
- i. Hooks or other devices should be provided on the tester, or on the prime equipment, to attach the tester to the equipment during the test.
- j. An adjustable harness or sling should be provided to facilitate carrying test equipment.

MIL-HDBK-759B

- k. If the test equipment has a removable cover, handles or grips should be provided on the sides of the test equipment for carrying it when the cover is not attached.
- l. Portable test equipment should have rounded corners and edges for safety.
- m. Hinged, permanently attached covers are recommended. If the test equipment must have a removable cover, it should be labeled with the same identification as the test equipment.
- n. Tester connectors should be clearly labeled with the type of electrical source that should be used.
- o. Panel lighting should be provided so the tester can be used under conditions of low or high illumination.
- p. Stands should be provided, so the tester can be used under conditions being used.
- q. The weight and dimensions of portable test equipment should not exceed those listed in Table 69.

TABLE 69. Weight and dimension limits of portable test equipment

Dimensions	Operability Hand-Held		Portability	
	Optimum	Maximum	One Person Maximum	Two Persons Maximum
Weight (kg)	1.4	2.3	11.3	40.8
Height (mm)	50	100	460	485
Length (mm)	200	255	460	--
Width (mm)	100	125	255	--

MIL-HDBK-7596

5.6.22.3.8 Design of hand-held testers.

- a. Hand-held testers should be used for making measurements at fairly inaccessible locations.
- b. Hand-held testers should be small, lightweight, and conveniently shaped.
- c. Hand-held testers should not weigh more than 2.3 kg and should be capable of being held and operated with the same hand (Figure 126).

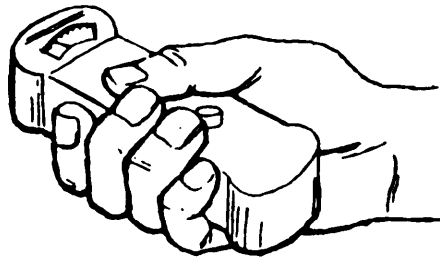

(A) Design for one hand operation

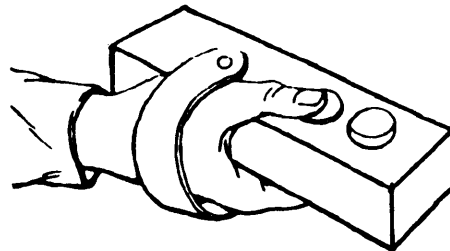

(B) With hand support

FIGURE 126. Hand-held testers

- d. The hand-held tester should have a grip on the underside through which the hand can be inserted (see Figure 126). This grip will reduce the probability of dropping the tester and will eliminate the necessity of holding the tester with both hands.
- e. The underside of the tester should be serrated or ridged to prevent it from slipping out of the operator's hand.
- f. The tester should be equipped with a string or strap so the operator can place it around his neck when it is not in use; the tester can then stand free and leave both hands free for other tasks. A means should also be provided to clip or attach the tester to the operator's body or clothing to prevent the tester from

MIL-HDBK-759B

swinging into other equipment or interfering with accomplishment of other tasks when not in use.

- g. Hand-held testers should be as functionally simple as possible.
- h. The tester should be self-powered and not require attachment to an electrical outlet.
- i. The indicator on the tester should be of the simple go/no-go type with a light to indicate out-of-tolerance conditions. If a meter is necessary, tolerance zones should be color coded.

5.6.22.3.9 Design of console-type testers.

- a. Modular design should be used to the greatest extent possible; and off-the-shelf units should be specified whenever they are available.
- b. Equipment should be designed so that consoles can be converted from one function to another by replacing modules.

5.6.22.3.10 General considerations for operation and maintenance of test equipment.

- a. Equipment should be made simple to operate and provide self-checking calibration features.
- b. Test equipment should be designed for one-person operation.
- c. A simple method to calibrate test equipment should be provided. Equipment should be equipped with a go/no-go indicator or simple check to determine whether the tester is malfunctioning or needs calibration.
- d. A warm-up indicator should be provided if applicable. Required warm-up time should be indicated clearly near the warm-up switch if no visual signal is provided. Warm-up procedures should be explicit.
- e. A simple check should be incorporated into the tester for testing the accuracy of the results.
- f. Conversion tables should be provided when needed.
- g. Attached instructions that clearly indicate the purpose of the tester and special caution for its use should be provided.
- h. Set-up procedures should be provided on an instruction card attached to the equipment.
- i. Tests necessitating quantitative readings and adjustments by operating personnel should be avoided. Information should be furnished by qualitative,

MIL-HDBK-759B

positive signaling devices, such as color-coded signals and zero-center meters, or similar means of indication.

- i. Equipment should be designed either to prevent the operator from making errors or to warn the operator of errors.
- k. Components or equipment should be clearly labeled as to whether it is to be used with alternating or direct current.
- l. Circuit breakers should be provided on all testers to safeguard against damage if the wrong switch or jack position is used.
- m. Fail-safe features should be incorporated into the equipment to minimize the danger to operator and/or equipment should failure occur.
- n. Regularly stocked standard components and units should be specified.
- o. If components are physically interchangeable, they also should be functionally interchangeable.
- p. Test equipment should be designed to be as rugged as the conditions of its use; that is, equipment to be used in the field should be more rugged than that built for laboratory use.
- q. Controls, dials, and adjustments should be designed to prevent misalignment caused by vibration, service use, or accidental contact.
- r. Safeguards against equipment damage from inadvertent human error should be provided.
- s. Equipment should be provided with devices to ensure that it is turned off when testing is completed.
- t. Power switches should be provided to shut off automatically when the tester lid is closed.
- u. A device to indicate that power is on should be included on the tester panel.
- v. Controls should be designed to prevent equipment damage if it is operated at the wrong time or in the wrong manner.
- w. Delicate components should be located where they will not be damaged while the unit is being operated.

5.6.23 Test equipment checklist. A summary of some of the important test equipment design recommendations is presented below. The checklist contains several items which were not discussed separately in the text. These items are included here because their necessity in the design is so obvious that they might

MIL-HDBK-759B

otherwise be inadvertently overlooked. In using the checklist, if the answer to any question is no, the design should be restudied to ascertain the need for correction.

- a. Are the instructions for using the test equipment in a step-by-step format?
- b. Is there a signal which shows when the test equipment is warmed up?
- c. If it is not feasible to present such a signal, is the warm-up time required clearly indicated near the power switch?
- d. Is a simple check provided to indicate when the test equipment is out of calibration or is otherwise not functioning?
- e. Is an appropriate indication of test equipment performance provided so the technician does not attempt to measure with a faulty standard or instrument out of calibration?
- f. Do test equipment displays, which require transformation of values, have conversion tables attached to the equipment with the transform factor by each individual switch position or display scale?
- g. Is adequate support provided for test equipment which should be taken into the work area?
- h. Are built-in test features provided wherever standard portable test equipment cannot be used?
- i. Does portable test equipment weigh under 11.3 kg if it is to be carried by one person?
- j. Do plugs, jacks, and binding posts used for testing test equipment appear on the outer casing of equipment, so it is unnecessary to remove the case? If internal repair requires removal of the case, are duplicate jacks and plugs provided on the chassis so "jury-rig" connections to the case are unnecessary?
- k. Are a display light, automatic power switches, or printed warnings provided to ensure that test equipment is turned off when testing is completed?
- l. Is storage for cables and test leads (within test instrument case lid) designed so the loose cables cannot interfere with closure of the case?
- m. Are the purposes of the test equipment and special cautions displayed in a conspicuous place on the outer surface of the test equipment?
- n. Are units which are not self-checking designed to be checked in the operating condition, without the aid of special rigs and harnesses, wherever possible?
- o. Are selector switches provided in lieu of a number of plug-in connectors?

MIL-HDBK-759B

5.6.24 Electrical equipment.5.6.24.1 Batteries.

- a. Batteries should be installed in locations away from sources of heat and be protected in such a manner as to ensure satisfactory functioning within the maximum and minimum operating ambient-air temperature limits.
- b. Battery holders should be rugged and have easily operated clamping devices, not requiring the use of tools, to hold the battery firmly in position against all vibrations, motions, and shocks (such as from gunfire).
- c. One person should be capable of rapidly and easily removing batteries for servicing and replacement without removing other items of equipment, and without using special tools.
- d. Complete freedom of access should be provided for replenishing the electrolyte and testing the specific gravity and voltage. Loose filler caps should be avoided whenever possible.
- e. Dust caps should be provided so battery terminals cannot contact metal surfaces during handling, removal, or replacement.
- f. Battery supports, hold-downs, and areas around the installation, which could possibly be affected by dripping or seepage of acids, should be protected with acid-proof paints or coatings. Battery cases should be drained overboard with acid-proof piping, when required.
- g. Batteries should be located in well ventilated areas and have facilities to prevent freezing, when necessary.
- h. Batteries should not be charged in a poorly ventilated compartment where explosive mixtures of hydrogen and air may result.
- i. Batteries should have special filler caps and palladium catalysts to reconvert hydrogen and oxygen into water, thus reducing noxious fumes in the battery area.
- j. To prevent gas explosions, only electrical fixtures approved for hazardous locations should be used in battery compartments.
- k. Quick-disconnects should be provided on battery leads for power-off maintenance or emergencies.
- l. Labeling should be provided as necessary to identify the battery type, voltage, polarity, and safe rate of charge. An example is the rate which will preclude production of dangerous concentrations of hydrogen gas and excessive heat. All related terminals, connectors, contacts, and leads that are part of the

MIL-HDBK-759B

battery circuit should be identified. When practical, a block or pictorial wiring diagram of the battery circuit should also be provided.

- m. Batteries with “dry” electrolytes should be installed according to the preceding criteria when they apply, except that certain types of dry batteries may be installed in sealed containers without ventilation. Dry electrolytic batteries should be mounted in housings which will keep them dry from water, moisture, and contaminants. “Plug-in” designs installed without tools or loose parts should be used wherever possible.

5.6.24.1.1 Shelf life of dry batteries. To increase the shelf life of dry batteries, they should be encapsulated in plastic films or in watertight metal cases. Batteries should be stored in cool places.

5.6.24.2 Fuses and circuit breakers.

- a. Fuses or circuit breakers should be provided so that each unit of a system is separately fused and adequately protected from harmful variations or transient voltages.
- b. When fuses are used, they should conform to MIL-F-15160.
- c. Fuses should be located on the front panel of the unit where they can be seen and replaced without removing other parts. Fuses should not be located inside the equipment.
- d. Fuses should be grouped in a minimum number of central, readily accessible locations, and should be replaceable by the equipment operator whenever possible, without the use of tools.
- e. Fuses should be provided which safeguard the circuit if the wrong switch or jack position is used and overload indicators should be provided on each major component.
- f. Spare fuses should be provided and located near the fuse holder, and labels adjacent to the fuse holder should provide both fuse value and function. (If space is limited, provide fuse value rather than fuse function.)
- g. Fuse holder cups or caps should be the quick-disconnect rather than the screw-in type; they should be knurled and large enough to be removed easily by hand.
- h. To protect the fuse and fuse holder against corrosion, whenever practicable, the fuse (including the contact surfaces) and the interior of the fuse holder should be coated with a silicone electrical lubricating compound. The exterior of the fuse holder, except contact surfaces, should be coated with fungicidal varnish. If possible, sealed fuses should be used.

MIL-HDBK-759B

- i. Fuse installations should be designed so that only the “cold” terminal of the fuse can be touched by personnel.
- j. When selecting fuses or circuit breakers, consider the suitability of each to perform a particular function (see Table 70). There are two types of circuit breakers, thermal air and magnetic air. Thermal-air circuit breakers are used primarily for overcurrent circuit protection. They are best adapted to DC circuits up to 250 volts, and to AC circuits up to 600 volts in capacities up to 600 amperes. Magnetic-air circuit breakers may be used to provide protection in event of overcurrent, undercurrent, reverse current, low voltage, and reverse phase.
- k. Fuse ratings should be indicated adjacent to the fuse in whole numbers, common fractions such as 1/2, or whole numbers and common fractions such as 2 1/2.

5.6.24.3 Relays.

5.6.24.3.1 General. If possible, circuits should be designed to avoid the use of relays. When relays are required, they should be the largest size practical and be made of the highest grade of arc-resistant material. The circuits should include a positive feedback loop through a set of relay contacts to ensure proper operation of the relay. The feedback loop may be part of the circuit function or a separate circuit used for troubleshooting.

5.6.24.3.2 Mercury-type. Mercury-type relays should be used whenever possible, but the angle of tilt should be kept in mind. Since liquid automatically seeks the lowest level, contact will be broken should the relay tilt more than 30° from the vertical. This limitation rules out many airborne applications.

5.6.24.3.3 Vacuum-/gas-filled. To avoid oxidation of relay contacts, glass enclosed vacuum- or gas-filled relays should be used. If the circuit is extremely critical, consider “out-gassing” of materials after periods of storage even though a vacuum initially prevailed.

5.6.24.3.4 Moist environments. Hermetically-sealed relays should be used for applications in moist or salty environments because natural organic insulators, such as paper or cotton, can contribute to the corrosion of windings in the presence of moisture or high direct current potentials. Synthetic insulating materials should be used to reduce these effects.

5.6.24.3.5 Power transients. Relay operation can cause transients in the power supply if large currents are applied, or interrupted by the relay. If operation at minimum current is not possible, decoupling networks and filters may be necessary.

MIL-HDBK-759B

5.6.24.3.6 Time delays increase relay lifespan. The time delay between the application of coil current and the closing of contacts will increase with the life of the relay as spring members fatigue. If close timing is important, external circuits, copper slugs in the relay core, or air dashpots should be used to control the delay.

TABLE 70. General comparison of fuses and circuit breakers

Function	Fuse	Circuit Breaker	
		Thermal Air	Magnetic Air
Instantaneous action	x		x
Time delay features	x	x	x
Resetting		x	x
Adjustable tripping range for other than maximum setting			x
Automatic resetting			x
Remote control resetting and tripping			x
Overcurrent protection	x	x	x
Low current, reverse current, reverse phase, and low voltage protection			x

5.6.24.3.7 Shock and vibration. The effects of shock and vibration can be decreased by using relays with contacts that are mounted on short, thick supports. Wiping, or follow-through contacts, such as those used in a stepping relay, should be used when the relay will be subjected to shock and vibration. Relays should be used in the energized position, if possible, as the holding force is greater, and there is less danger of inadvertent opening. Adequate current should be supplied to the coil to obtain the strongest armature attraction.

5.6.24.4 Ignition equipment. Ignition equipment for internal combustion engines should be designed to have the following maintainability characteristics:

- a. Spark plugs should be of the highest quality and reflect the most advanced technology in the state-of-the-art. Materials selected should provide maximum life, ease of adjustment, and maintenance. Self-cleaning types should be used wherever possible.

MIL-HDBK-759B

- b. Distributors should be located to permit rapid and easy access to all maintenance points, close line of sight inspection, and rapid total removal and assembly. Flywheels used for timing should be clearly and adequately marked by engraving or deep stamping, and be provided with an accurate rigid pointer.
- c. Ignition points should be designed and located for rapid removal, adjustment, and assembly.
- d. Ignition timing advance mechanisms should be rapidly and easily replaceable and capable of inspection.

5.6.24.5 Dynamotors. Dynamotors should be designed to allow for the use of commutator dressing and burnishing stones and should be mounted so they do not have to be removed to dress and burnish the commutator.

5.6.24.5.1 Slip rings. Slip rings should be protected from the entrance of dust and moisture and should be self-cleaning and accessible for servicing. These assemblies should be provided with extra slip rings, where practicable, for emergency repairs.

5.6.24.6 Wiring and cables.

5.6.24.6.1 General. Standardized connectors should be provided for inter-vehicle connection. Bonding points should be accessible and their securing screws should have vibration-proof washers.

5.6.24.6.2 Safety precautions. The following general safety precautions should be adhered to during selection, routing, and maintenance of wires and cables.

- a. Test points should be provided for checking components when their terminals are not accessible.
- b. Electrical shielding should be easy to remove.
- c. All ground return connections should be brought to a common, grounded, bus bar.
- d. All wiring should be positioned away from sharp corners.
- e. Wiring passing through unprotected holes in metal parts should be protected by grommets.
- f. All electrical cables should be oil-proof, unless their location provides adequate protection against contact with oil.
- g. Exposed cables should be protected from mechanical damage. (Consider the use of armored cables in such installations.)

MIL-HDBK-759B

- h. Long unsupported lengths of cable or wire should be avoided.
- i. Cables may be run inside frame members, providing they are accessible and not exposed to heat or oil.
- j. Electrical cables should be color-coded or tagged for ease of identification.
- k. Electrical cables should be of the quick-disconnect type wherever possible (see Figure 127).
- l. Wires and coverings should remain flexible at the low temperatures encountered in cold regions.

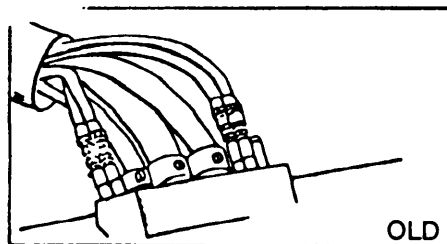

FAULT:

TIME REQUIRED FOR REMOVAL OF CABLES WAS APPROXIMATELY 2 HOURS. REMOVAL OF 10 OR 15 INDIVIDUAL BOLT-ON CONNECTIONS AND DRAWING HARNESSSES OUT OF BOXES AND THROUGH CONDUCT M/III RESULT IN HIGHER MORTALITY RATE ON WIRING AND UNNECESSARY DOWNTIME FOR VEHICLES.

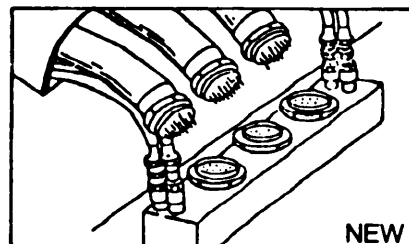

CORRECTIVE ACTION REQUIRED:

RECOMMENDED THAT WIRING HARNESSSES RUNNING FROM THE PRIME MOVER TO EITHER THE FUEL TANKER OR THE CARGO CARRIER BE EQUIPPED WITH QUICK-DISCONNECT FITTINGS, PIN AND SOCKET TYPE QUICK-DISCONNECT FITTINGS CAN BE SEPARATED IN NO MORE THAN 3 MINUTES FOR ALL THREE CABLES,

FIGURE 127. Cable connections

5.6.25 Mechanical equipment.

5.6.25.1 Accessibility. Equipment design for accessibility should include the following considerations.

- a. Provide access openings for instrument adjustment.
- b. Provide external access to internal adjusting devices.
- c. Locate high-mortality parts near access openings.
- d. Make lubrication points easily accessible and clearly marked.
- e. Make mounting bolts easily accessible.

MIL-HDBK-759B

- f. Avoid through bolts having nuts that are inaccessible except through extensive disassembly of adjacent parts.
- g. Socket-head screws should not be used where relative inaccessibility would require special or modified hexagonal wrenches.

5.6.25.2 Standardization. The following standardization practices should be followed in design of equipment.

- a. Standardize types and sizes of bearings where practical.
- b. Standardize knob set screws so that a standard diameter and thread are used for a given shaft diameter.
- c. Standardize tolerances on similar parts for interchangeability.
- d. Standardize the method of pinning gears; set screws should be used where keyways or splines are used.

5.6.25.3 Safety. The safety features listed below should be considered.

- a. Doors or hinged covers should be designed so they are rounded at the corners and provide slip hinges and stops to hold them open.
- b. In mounting fire control components, access to both sides of the equipment should be provided, and sufficient hand room should be provided for the technicians to remove and replace parts.
- c. Personnel should be provided with protection from moving mechanical parts by the use of guards, safety covers, and warning plates.
- d. Covers or boots for exposed couplings, and universal joints should be provided.

5.6.25.4 Other design considerations. The design of mechanical equipment should consider the ideas listed below.

- a. Interchangeable fastening devices should be used, and the number of types and sizes of bolts, nuts, and screws should be kept to a minimum. Where practicable, lock washers should be attached to the bolts and screws.
- b. Fast-acting fastening devices should be used for covers and cover plates that are of the captive type and do not require special tools.
- c. Corrosion-resistant, sealed bearings should be used in all fire control materiel, except where the sleeve type has a logical application.
- d. Wherever possible, self-aligning bearings should be used instead of ball caps and sockets in worm gear mechanisms.

MIL-HDBK-759B

- e. Securing bearings by staking should be avoided; stakes have a tendency to break when in use for prolonged periods of time.
- f. Dual doweling should be eliminated. Instead, eccentric dowels, dowels with stopscrews, with slots, with edge-locating shoulders, and with keys should be used.
- g. Where possible, the use of split pins should be avoided; taper pins are more desirable.
- h. Split clamp couplings should be used instead of pinned sleeves to facilitate the replacement of parts and adjustments.
- i. Ferrous parts that are susceptible to corrosion and are used internally in instruments should be cadmium plated (using the Cronak or an equivalent inhibiting process). Phosphate finishes (especially where not oiled) do not provide sufficient protection.
- j. Oil-impregnated bearings should be used where practical.
- k. Related subassemblies should be grouped together as much as possible.
- l. A manual means for the engagement, disengagement and locking of elevating and traversing mechanisms should be provided to facilitate maintenance.
- m. In high-speed applications, it should be specified that mating gears be of materials having dissimilar wear characteristics.
- n. Backlash and torque lash should be minimized. The effects of backlash and lost motion should be taken into consideration in the selection or design of movable parts.
- o. The same type socket should be used on all socket set screws.
- p. Screws, studs, and nuts made of non-ferrous material should be used where practicable.
- q. Using dowel pins for the final positioning of mounts on support surfaces provided on the weapon should be avoided; fixed locating points present a problem when mounts are interchanged. Consider key and keyway, eccentric and keyway, or single dowel pins for the final positioning of mounts.

MIL-HDBK-759B

5.6.26 Hydraulics.

5.6.26.1 General. Hydraulic systems are used in tractor and earth-moving equipment. Power pumps and positive-displacement motors are common on industrial, construction, and other types of engineering equipment. Hydraulic systems are used to provide power for braking and for other applications in which an intermittent high amplitude impulse of power is needed. The advantage of the hydraulic system is that effective power may be stored by a small pump over a long duty cycle and expended in a short duty cycle impulse of high power. Use non-flammable fluid only for safety.

5.6.26.2 Standardization.

- a. Connectors in hydraulic systems should be of standard design and able to be handled with standard tools.
- b. Standardize, where practical, valves and cylinders, hose assemblies, couplings, fittings, and filters.
- c. Standard hardware should be used for mounting hydraulic components.
- d. Ensure that all connectors are standardized by content of lines, and that the number of different sizes are held to a minimum. If there is danger of mismatching connectors for adjacent lines carrying different fluids, specify physically incompatible connectors for the two lines.

5.6.26.3 Identification.

- a. Color coding should be used for hydraulic lines and valves at each end of the line.
- b. Permanent identification, instruction markings, periodic inspection dates, and drain schedules should be provided.
- c. Inlets, outlets, and connecting lines in hydraulic systems should be identified at least every 460 mm, and at both ends, to facilitate maintenance.

5.6.26.4 Drain cocks. All drain cocks should be readily accessible and hand operable without spillage on gloves by the full range of user personnel wearing arctic/NBC protective garments. Drain cock handles should be in-line with the corresponding pipe when ON and perpendicular to the pipe when OFF. On vehicular equipment vertical drain cocks should be operable only by upward movement of the handle. On horizontal lines the handle should be on top or bottom of the line or should be operable only by upward movement if on the side of the line. Drain cocks with high draining rates should be fitted to all air receivers and oil reservoirs.

MIL-HDBK-759B

5.6.26.5 Seals. Seals should be used which are eternally visible after they are installed. Costly accidents result when seals are left out during assembly or repair (see Figure 128). They should not protrude or extrude beyond the coupling since protruding seals are chipped and shredded by vibration or contact, and the damage spreads internally to destroy sealing power and deposit pieces in the line (NOTE: For low-temperature operation, special low-temperature materials should be used). Specify couplings which utilize permanent seals rather than those which should be removed and replaced when the seal wears out.

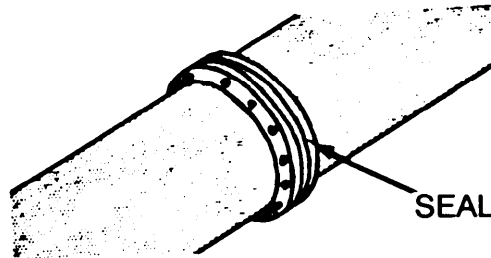

FIGURE 128. Use seals which are visible after installation

5.6.26.6 Design considerations. Hydraulic systems design should make use of the following considerations.

- a. All lines should be secured and free from accidental damage.
- b. Mechanical stops should be provided for valve handles to prevent the valves from opening because of vibration.
- c. Positive locking A-end pumps should be provided when in the traveling position.
- d. Self-sealing couplings should be provided on complex hydraulic and pneumatic systems to simplify identification.
- e. Hydraulic pumps, valves and lines, as well as other parts of hydraulic systems should be designed in accordance with the standards laid down in such references as the Society of Automotive Engineers (SAE) Handbook.
- f. The use of armor-covered flexible hose should be considered for hydraulic lines to facilitate replacement in the field from bulk stock.
- g. Aircraft-type safety fittings with built-in check valves should be used in hydraulic lines to limit fluid loss in the event of a line rupture.
- h. Automatic bleeding of hydraulic systems should be utilized whenever possible.

MIL-HDBK-759B

- i. Relief valves should be used in hydraulic lines to prevent their bursting and injuring personnel.
- j. Quick-release fastening devices should be used on connections that require frequent disconnection. Self-sealing features should be provided to prevent leakage of fluid when disconnect is made.
- k. Shock-proof pressure gauges should be used on all mobile equipment.
- l. Gauges should be selected that have an external pointer adjustment for ease of adjustment and calibration.
- m. Meters, gauges and control valves should be placed in a centralized position.
- n. Valves with integral limit switches should be used where practicable.
- o. Permanent or cartridge-type filters should be used.
- p. In case of electrical failure, a means for manually operating hydraulic systems should be provided.
- q. The connector recommendations shown in Figure 129 should be considered.
- r. To prevent fluid spraying or draining on the technician or nearby objects when fluid lines are disconnected during maintenance, the following design recommendations should be used.
 - (1) Provide line drains to ground or container at low level access points.
 - (2) Reposition line disconnects from sensitive components or shield the component.
 - (3) Provide a high visibility warning light at disconnect areas which are especially critical.

MIL-HDBK-759B

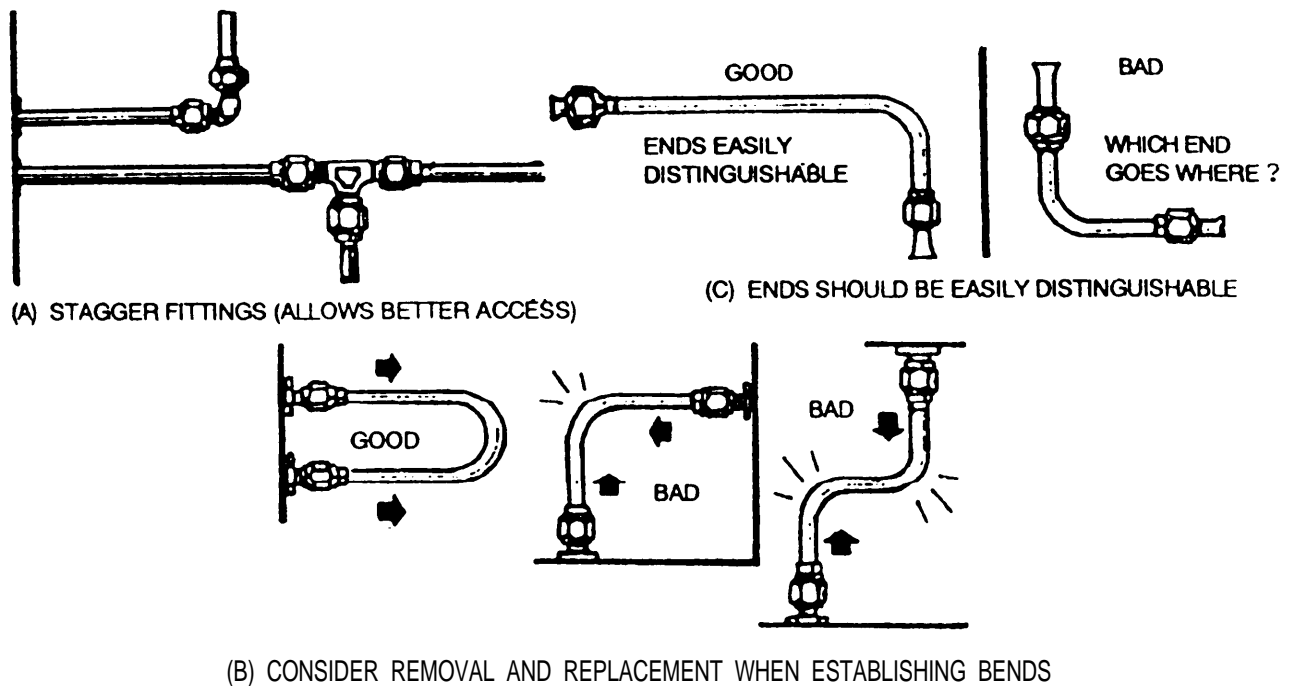

FIGURE 129. Connectors for fluid lines

5.7 Safety.

5.7.1 General. In evaluating equipment's safety characteristics, some of the areas which should be reviewed are:

- failure modes and hazardous effects,
- electrical and electronic safety factors,
- mechanical safety factors, including hydraulics and pneumatics,
- toxicity, and
- radiation.

5.7.1.1 Principles of human behavior related to safety. There are principles concerning human behavior that can help designers design safe equipment. The principles below are based on how people actually use equipment in the field, and on what actually does happen to that equipment. These principles give a partial answer to why people make errors, misuse equipment, and do other unsafe things. Armed with such knowledge of why people err, the designer can avoid many rather subtle temptations that give users opportunities to take chances.

Principle 1: If the equipment provided is insufficient or inadequate, users will modify it, or improvise, so they can get the job done.

MIL-HDBK-759B

Principle 2: Procedures should be definite and comprehensive.

Principle 3: People often feel that "it can't happen here." They assume that, if someone gets hurt (or damages equipment) by disregarding instructions, it will be someone else in some other place. Because people feel safer than they are, procedures should be as nearly foolproof as possible. Since procedures are shaped by the equipment, equipment should be designed to encourage safe usage.

Principle 4: Once a safety problem has arisen, taking corrective action does not necessarily eliminate it. The correction may not be sufficient, or may not be appropriate, or may even fail to attack the cause of the problem. Corrective actions should always be verified to determine if the problem has been solved.

Principle 5: Not all safety problems can be anticipated from studying concepts and blueprints. Thorough safety analysis requires realistic tests using mockups and prototypes.

Principle 6: Equipment not designed to operate in accordance with user expectancies and stereotypes will eventually lead to mistakes.

Principle 7: Warning notes have a limited, supplementary value in making mishaps less probable. However, many users may not have read them, or may not remember them, or may not even know where to find them. Warning notes do not prevent safety problems.

Principle 8: Accidents seem so unreal to some people that they do not appreciate how careless performance can cause accidents. Before these individuals take their assignment seriously, and do it thoroughly and carefully, they must actually see equipment damaged or people injured.

Principle 9: Equipment should be designed so it is inherently safe to use, rather than relying on special safety training to prevent accidents. Not all users get such training, even when it is "required."

Principle 10: Equipment users do not visualize the consequences of unsafe acts. These people only realize a practice is dangerous after they have seen someone get hurt.

Principle 11: Certain individuals seemingly prefer to work under hazardous conditions, as if their bravery makes the job more important.

Principle 12: Instructions, like warning notes, are not enough to ensure operators will work safely.

Principle 13: Designers should consider the possibility for errors, listing the possible mistakes the operator can make, and their consequences.

MIL-HDBK-759B

Principle 14: Some accidents occur because technicians cannot identify parts correctly. Designers should provide complete, legible, understandable identification of parts in order to avoid personnel injuries and equipment damage.

Principle 15: Many designs require compromises, but every effort should be made to minimize conditions which could lead to accidents. If undesirable conditions are tolerated without making an effort to improve them, they often seem to multiply and interact to produce serious safety problems.

Principle 16: Equipment should be designed so it can be used safely. If the procedures for safe operation seem needlessly difficult or burdensome, people tend to avoid doing what seems unnecessary. Ideally, equipment should be designed so it is easier to use it safely than to use it unsafely.

Principle 17: Designers should anticipate that operators do make mistakes and assure that these mistakes are not likely to injure personnel or damage the equipment. For example, users should be given at least some on-the-job training with operational equipment; these partially trained personnel should be expected to make errors.

Principle 18: The designer should understand all of the criteria the equipment should satisfy; comprehending these requirements can assure that the equipment will meet them.

Principle 19: The operator's care in using and maintaining items tends to be related to their complexity and cost. People are most careful with complicated, expensive items. Conversely, individuals tend to neglect simple, inexpensive items because they seem relatively unimportant.

Principle 20: Since workers often neglect their own safety, each supervisor should take responsibility for certain areas concerning personnel and equipment safety, and particularly for unwise short-cuts and variations from the prescribed procedures.

Principle 21: Abbreviated checklists tend to cause mistakes. Checklists may be useful if the personnel are well trained. However, less knowledgeable technicians may not go beyond the checklist when working in unfamiliar areas. Rather than refer to the detailed job procedures, they tend to experiment or fill in the gaps by guessing.

Principle 22: The equipment's reputation among users can be very important, because it may affect the way they use it and service it. Even rumors that equipment is difficult or hazardous to use can compound and magnify the basic difficulty.

Principle 23: Ease of use or maintenance affects equipment reliability. If items are difficult to maintain, technicians will probably not keep them in good operating condition. If equipment is difficult to use, operators will substitute other equipment when they can.

MIL-HDBK-759B

Principle 24: Equipment is particularly susceptible to misuse if crew members must communicate with each other to use it. People seldom realize communications are inadequate until they make mistakes.

Summary: The designer should remember that most safety problems concerning operational equipment arise not from defects in the equipment, but because people use it improperly. Realistically, we should expect that this improper use will continue in the future. Therefore designers should strive harder to anticipate how their equipment might be misused, and to design equipment so misuse becomes unlikely and its effects are not catastrophic. It is obviously much more effective to design to prevent misuse, rather than attempting to reduce safety hazards from manufactured equipment.

5.7.2 Electrical hazards. The primary reference in designing electrical equipment is MIL-STD-454, "Standard General Requirements for Electronic Equipment."

5.7.2.1 Electric shock. The principal electrical hazard is shock. The effects of electric shock depend on the body's resistance, the current path through the body, the duration of the shock, the amount of current and voltage, the frequency of an alternating current, and the individual's physical condition. The most critical determinant of injuries is the amount of current conducted through the body. Besides the obvious risk of burns and injuries to the nervous system, electric shock can produce involuntary muscular reactions that injure people and can damage equipment.

5.7.2.1.1 Hazards. All electrical systems of 30 volts or more are potential shock hazards. Research reveals that most shock deaths result from contacts with electrical systems ranging from 70 to 500 volts. Under extraordinary circumstances, even lower voltages can cause injury. Shock causes many severe injuries by evoking muscular spasms and reflexes that propel the body against nearby objects. Table 71 summarizes typical effects of various levels of electrical current.

TABLE 71. Shock current intensities and their probable effects

CURRENT (milliamperes)		EFFECTS
AC (60Hz)	DC	
0-1	0-4	Perception
1-4	4-15	Surprise
4-21	15-80	Reflex Action
21-40	80-160	Muscular inhibition
41-100	160-300	Respiratory Block
Over 100	Over 300	Usually Fatal

MIL-HDBK-759B

5.7.2.1.2 Prevention of electric shock. Personnel should be protected from electrical shock by suitable interlocks, grounding, and enclosures or other protective devices. The main method of alerting personnel to potential shock hazards is through effective visual and audible warnings.

5.7.2.1.2.1 Color. Equipment designed for safety, protective, or emergency functions should be colored in conformance with MIL-STD-1473.

5.7.2.1.2.2 Danger markings & Signals. Hazards retaining some risk to personnel or property should be identified to personnel before they enter a hazardous area or initiate a hazardous activity.

5.7.2.1.2.3 Danger Markings. Hazard markings should warn personnel about specific hazards, the mishap which could result from the hazard, and the precautions that they should take. The markings should conform to appropriate standards and be large enough to be read from outside a hazardous area. They should be located so that they will be observed before a hazardous activity is initiated. Hazard markings should conform to MIL-STD-1473 and MIL-STD-454, Requirement 1.

5.7.2.1.2.4 Warning signals. Warning signals such as lights, bells, horns, or other devices should be used to alert personnel of danger. These signals should be located where the people who must take corrective action can perceive them most easily. Multiple redundant warning signals, lights, and bells may be required if ambient noise could mask the audible alarm, or personnel might not be looking at a warning light.

5.7.2.1.3 Safety switches. The two basic types of safety switches for preventing electric shock are interlocks and main-power switches.

5.7.2.1.3.1 Interlocks. An interlock is a switch that automatically turns power off when the equipment's access door, cover, or lid is open. These switches are ordinarily wired into the "hot" lead to the power supply and operate whenever an access cover is opened, thus breaking the circuit whenever personnel enter the enclosure. Every door or cover that provides access to high-voltage potentials should have an interlock. Selection of the type of interlock switch to be used should be based on reliability. The type shown in Figure 130 has proven most satisfactory.

MIL-HDBK-759B

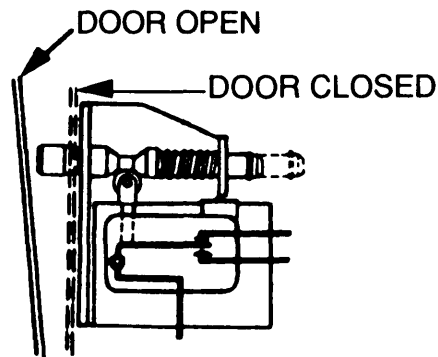

FIGURE 130. Door interlock switch

5.7.2.1.3.1.1 Maintenance. The use of interlocks assures that power is off during maintenance. If maintenance personnel must open the equipment and work on it while the power is on, there should be some provision for bypassing interlocks. Such bypass switches should be located inside the equipment in a position where closing the access door or cover automatically restores interlock protection. Wherever these bypass switches are used, there should also be a warning signal to show personnel that there is danger because the interlock has been bypassed. These warnings should include a flashing red light as well as an appropriate warning plate or decal.

5.7.2.1.3.2 Battle-short switch. Wherever complicated interlocks are used on high priority equipment, there should be a battle-short switch (or terminals for connecting one) which bypasses all interlocks. The circuit consists of a single switch, wired in parallel with the interlock system. Closing the battle-short switch thus short circuits all of the interlock switches, turning power on regardless of whether interlocks have been opened. Whether mounted on the equipment panel or remotely, battle-short switches are for emergency use only, and they should be so marked. They should have adequate protection against accidental operation such as seals which must be broken before the switch can be operated. In addition, switches should also have appropriate warning devices to alert personnel that interlocks have been bypassed.

5.7.2.1.3.3 Main-power switch. Each item of equipment should have a clearly labeled main-power switch that turns off all power to the item by opening all leads from the main-power service connection. Main-power switches should be safeguarded to prevent heavy arcing. Fuses and conductive metal parts should be isolated from each other with barriers. The switch box should also be designed so the box cannot be opened when the switch is turned on. Such switches are available as standard, commercial equipment.

5.7.2.1.3.4 Discharging devices (bleeders). Because high-quality filter capacitors can store lethal charges for relatively long periods of time, all medium- and high-voltage power supplies should have devices that discharge them when they are turned off. Bleeders should be incorporated in all power supplies where the product of

MIL-HDBK-759B

resistance (in ohms) and capacitance (in farads) is three seconds or more. Since no one discharging method meets the criteria for all devices, the examples listed below are presented as guidelines.

- a. DC power supplies may be discharged very satisfactorily by permanently connecting a bleeder resistor across the output terminals. This bleeder serves to improve the supply's regulation, and to discharge the filter capacitors when the supply is turned off. Although bleeder current is an additional load on the power supply, the supply should be designed to accommodate this extra load. The bleeder resistance should be the lowest value that does not load the power supply excessively so it can discharge the capacitors quickly after power is turned off. An adequate bleeder should discharge the capacitors fully in one minute or less.
- b. Some circuits with large, high-voltage capacitors (high-voltage radar equipment) cannot use bleeder resistors so other methods should be used to discharge the capacitors before doing maintenance. Often capacitors are discharged with a shorting or grounding rod that has a well-insulated handle. It is a better engineering practice to discharge capacitors gradually, rather than shorting them, and high-power resistors are often used in place of a grounding rod; several thousand ohms of resistance is a typical value.
- c. Interlocks should remove power before automatic shorting bars (see Figure 131), operated by mechanical releases or electrical solenoids, can discharge the power supply quickly when covers or access doors are opened. These bars should operate automatically whenever the enclosure is opened; they should function quickly, with high reliability.

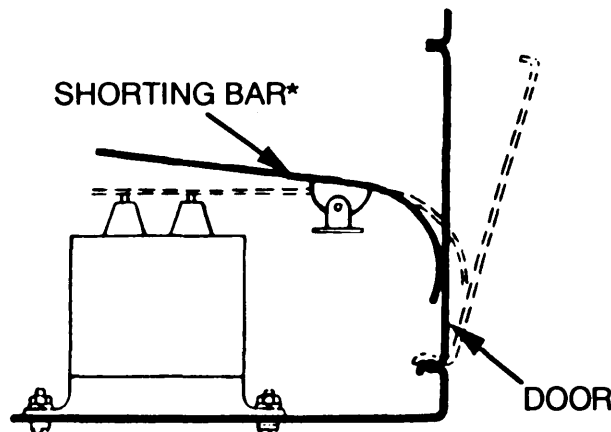

*Should be spring-loaded to ensure operation in all equipment positions

FIGURE 131. Automatic shorting bars

5.7.2.1.4 Grounding. AH enclosures, exposed parts, and the chassis should be kept at ground potential by the same common ground system.

MIL-HDBK-759B

5.7.2.1.4.1 Grounding techniques. Various grounding techniques are used to protect personnel from dangerous voltages in equipment. A terminal spot welded to the chassis provides a reliable ground connection. Where welding is not feasible, as with an aluminum chassis, the ground terminal should be fastened down by a machine bolt, lock washer, and nut (see Figure 132). Ground lugs should not be stacked on bolts with any material subject to coldflow. The machine bolts used to mount ground lugs should be large enough that eventual relaxation will not loosen the ground connection. A lock washer should always be used to keep the ground tight. Any non-conductive finish on the chassis should be removed before bolting down the ground lug. Ground lugs should not be attached with rivets because rivets do not give reliable electrical connections.

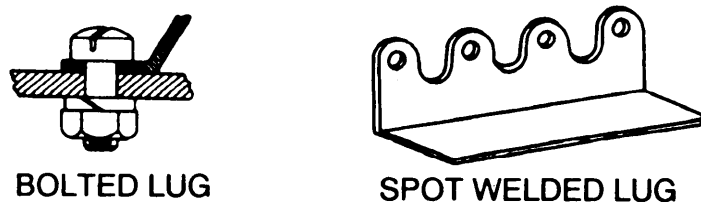

FIGURE 132. Grounding methods

5.7.2.1.4.2 Common around. The common ground of each chassis should connect to a through-bolt mounted on the enclosure and clearly marked "ENCLOSURE GROUND". An external safety ground strap should, in turn, be connected to this through-bolt. The external ground strap should be a suitably plated flexible copper strap with a current-carrying capacity at least twice as large as the equipment requires (see Figure 133).

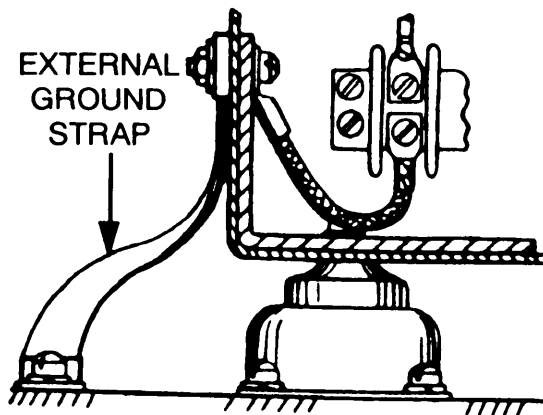

FIGURE 133. Cabinet grounding system

5.7.2.1.4.3 Test equipment. Electronic test equipment (signal generators, amplifiers, and oscilloscopes) which is plug connected should have an integral ground

MIL-HDBK-759B

prong to ensure automatic ground connection. These ground leads provide safe grounding because if a fault in the instrument puts a dangerous voltage on the metal housing it is bypassed without endangering the operator.

5.7.2.1.4.4 Panel-mounted components. Panel-mounted components, especially meters and test jacks, are occasionally used to monitor current in power lines. Such items should be connected into the grounded side of the power line rather than into the ungrounded side; this precaution limits current flow if the component should short to the grounded chassis.

5.7.2.1.4.5 Electrical Overload Protection. Circuits should be fused so that other parts of the circuit will not be damaged if a fuse is removed or if it ruptures. All leads from the primary power lines should be protected by fuses or circuit breakers as described in MIL-STD-454, Requirement 8. Circuit protection for wired-in equipment should be connected between the main-power switch and the load.

5.7.2.1.5 Fusing. Circuits should be fused so that other parts of the circuit will not be damaged if a fuse is removed or if it ruptures. All leads from the primary power lines should be protected by fuses. Fuses should be connected between the main-power switch and the load.

5.7.2.1.5.1 Fusing techniques. Branch-line holders should be designed so that, when correctly wired, fuses can be changed without risk of accidental shock. Where feasible, both of the fuse-holder contacts should be recessed so users cannot touch them. At least one of the fuse-holder contacts should be recessed where personnel cannot touch it, and that contact should be connected to the supply line; the accessible contact, if there is one, should be connected to the load. Figure 134 shows how an instrument-type fuse holder should be wired to keep users from touching the high-potential contact.

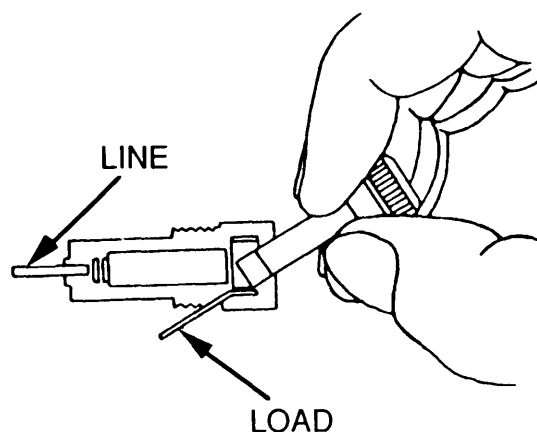

FIGURE 134. Correct manner of wiring instrument-type fuse holder

5.7.2.1.6 Power lines. While safety guidelines often concentrate on high-voltage apparatus, power line hazards also deserve close attention. Personnel who touch,

MIL-HDBK-759B

short circuit, or ground the incoming power line can receive severe shocks and serious burns. Both ends of the power line and all branches should be fused. Otherwise, a transformer or motor failure could ground the primary supply line.

5.7.3 Mechanical and other hazards.

5.7.3.1 Protrusions. All edges and corners should be rounded, having as large a rounding radius as practical. This prevents injuries from sharp or pointed edges. This rounding is especially important with front and side edges, and with door corners. Designers should avoid thin edges. Units should be designed so users can carry them without risk of cutting their hands on sharp edges. To minimize protrusions from equipment surfaces, flat-head screws should be used where possible; otherwise, pan-head screws should be used. To reduce the risk of skin abrasion, all exposed surfaces should be machined smooth, covered, or coated. In areas where users must make rapid movements, small projecting components should be avoided or covered. If small projecting parts (such as toggle switches or small knobs) must be mounted on a front panel, recessed mountings should be considered.

5.7.3.2 Moving and high-temperature parts. The equipment should have shields and guards to keep users from accidentally touching rotating or oscillating parts such as gears, couplings, levers, cams, latches, or large solenoids. Moving parts should be enclosed, shielded, or guarded. High-temperature parts should be located (or guarded) so users will not normally touch them. If such protection is not feasible, there should be prominent warning signs. Wherever possible, a guard should be designed so users can inspect parts without having to remove it. Especially if a part's failure can cause a hazardous condition, guards should not interfere with inspecting that part.

5.7.3.2.1 Ventilation. There should be enough ventilation to keep parts and materials from getting so hot that they will be damaged or their useful life will be shortened. Exposed parts of the equipment should never, under any condition of operation, get hot enough to endanger personnel. Hot components may be cooled with forced air. Any air-exhaust openings should be located where personnel are not exposed to direct drafts.

5.7.3.2.1.1 Perforations. Some housings, cabinets, and covers should be perforated to allow air circulation. Many small perforations are better than a few large ones; perforations should be no larger than the minimum size necessary to prevent expected operator and maintenance personnel from contacting the hazards inside the housing, cabinets or covers. Any component which rotates, oscillates, or carries high voltage should be spaced back from perforations so personnel cannot touch it accidentally.

5.7.3.2.2 Maintenance. When maintenance personnel must have access to rotating or oscillating parts, protective covers, housings, or doors should have interlocks, with bypass switches inside the equipment.

5.7.3.2.3 Electronic equipment. Electronic chassis should be securely enclosed when in their normal, installed positions. Chassis slides should have stops, so personnel will not pull the chassis too far out and drop it. A chassis should have

MIL-HDBK-759B

handles or similar hardware for pulling it out of its enclosure. It should also have bails or other appropriate hardware to protect components that will be exposed when the chassis is removed and turned over for maintenance and to protect the maintainer's hands when a heavy chassis is placed on a bench.

5.7.3.3 Fire. All reasonable precautions should be taken to minimize fire hazards. In particular, if capacitors, inductors, or motors are potential fire hazards, they should have non-combustible enclosures with a minimum of openings. Materials that can produce toxic fumes should not be used because equipment must often be installed in confined spaces. Designers should also avoid materials that, under adverse operating conditions, might liberate combustible materials. Equipment should be designed so it will not emit flammable gases during storage or operation; if any such gases are unavoidably emitted during operation, there should be automatic cutoffs and suitable warnings. Equipment should not produce undesirable or dangerous smoke and fumes. Finished equipment should be checked carefully to verify that protective features are actually effective.

5.7.3.3.1 Fire extinguishers. Where fire hazards are known to exist, or may be created by the equipment, there should be portable, hand-operated fire extinguishers. These fire extinguishers should be located so they are immediately and easily accessible. They should be selected for suitability to the class of fires most likely to occur in the area.

Class A. Fires of ordinary combustible materials (wood, paper, and rags) which can be extinguished with water or aqueous solutions.

Class B. Fires involving flammable liquids (gasoline and other fuels, solvents, greases, and similar substances) which can be extinguished by diluting, eliminating air, or blanketing.

Class C. Fires in electrical equipment (motors, transformers, and switches) which should be extinguished by a material that does not conduct electricity.

5.7.3.4 Toxic fumes. All reasonable precautions should be taken to eliminate hazards from toxic fumes. The exhausts from internal combustion engines, for example, contain numerous hazardous substances. From the standpoint of practical health-hazard control, the most important hazards are carbon monoxide from gasoline engines, and aldehydes and nitrogen oxides from diesel engines. (see 5.4.7). Other toxic fumes may be produced by batteries, cleaning chemicals, hydraulic fluid sprays, etc..

5.7.3.5 Implosion and explosion.

5.7.3.5.1 Implosion. CRTs pose a special hazard because minor physical damage (accidental nicks or scratches) may trigger later implosions. Therefore, the face of CRTs should always be shielded by shatter-proof glass attached to the panel. The terminal end of CRTs should be located within the equipment housing whenever possible. If the terminal end should extend outside the equipment housing, it should have a sturdy cover to protect the tube. This cover should be anchored to the main housing structure firmly enough to withstand shipping and rough handling so that external pressures will not be transmitted to the tube and its wiring. There should also

MIL-HDBK-759B

5.7.3.5.2 Explosion. Equipment that may be operated, maintained, or stored in an explosive atmosphere should be designed to eliminate the possibility of an explosion. All electrical equipment that will be used near flammable gases or vapors should be explosion-proof. Risk of explosion should be minimized by isolating hazardous substances from heat sources and by using spark arrestors, vents, drains, and other safety techniques as appropriate.

5.7.3.6 Instability. Equipment should be designed for maximum stability. Particular attention should be given to portable equipment such as maintenance stands, tables, benches, platforms, and ladders. Walkways, catwalks, and any surfaces used for climbing should have non-skid metallic materials, expanded metal flooring, or abrasive surfaces. Ladders and steps should be designed so they can be de-iced with hot water or steam. There should be hand grips on platforms, walkways, stairs, and around floor openings. Hand grips should ordinarily be fixed, but sometimes hand grips should fold or telescope so they are concealed or flush with the surface except when being used. Folding grips should remain securely folded when not in use, but users should not need tools to open them for use.

5.7.3.6.1 Adjustable stands and platforms. Adjustable stands and platforms should have foolproof self-locking devices that keep them from collapsing accidentally. Where stands have high centers of gravity and might overturn, they should have anchors or outriggers to stabilize them. To prevent overloading, weight-sharing equipment such as stands, hoists, lifts, and jacks should be marked to show weight capacity in kg.

5.7.3.6.2 Safety. Equipment should be designed to maximize safety and stability when it is moved on inclines, such as cargo ramps, or lifted by cranes for shipping. The center of gravity and jacking points should be suitably marked to show their locations (see Figure 135). Users should be aware that ramps and inclines change the way weight is distributed among the wheels; the lower wheels bear weight. With heavier equipment, this may mean that weight is concentrated enough to exceed allowable ramp loads. Shifting the center of gravity also increases the risk that equipment will overturn.

5.7.3.7 Ionizing and non-ionizing radiation. Potential hazards arising from nuclear, microwave, radio frequency, X, and laser radiation should be evaluated by specialized personnel trained in investigating and controlling such hazards.

5.7.4 Safety checklist. The checklist below summarizes the general areas designers should consider in protecting personnel and equipment. Several items are included here, although not discussed previously, because they seem so obvious that they tend to be overlooked. A “no” answer to any question in

MIL-HDBK-759B

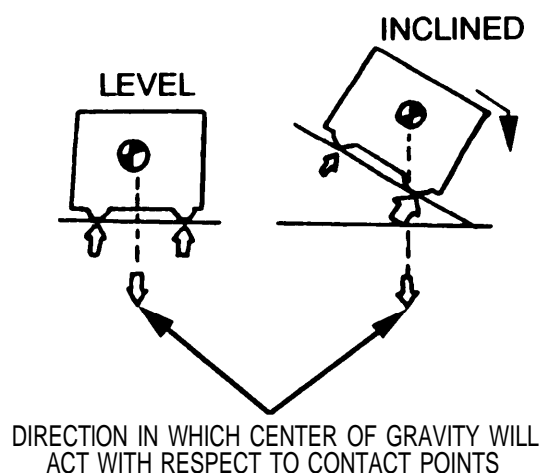

FIGURE 135. Effects of incline on center of gravity location of equipment

the checklist means the equipment should be reevaluated to improve its safety characteristics.

- a. Do all moving parts of machinery and transmission equipment have mechanical guards?
- b. Are edges of components and access openings either grounded or protected by rubber, fiber, or plastic?
- c. Are there portable, hand-operated fire extinguishers near places where fires might occur?
- d. Are fire extinguishers the correct type?
- e. Are fire extinguishers located so they are readily accessible yet where fires will not block access to them?
- f. In vehicles, is the correct type of fire extinguisher mounted on the vehicle at the driver's position?
- g. Are audible signals distinctively recognizable and unlikely to be masked by other noises?
- h. Are fault-warning systems designed to detect weak or failing parts before an emergency occurs?
- i. Are the most critical warning lights grouped together within the operator's normal field of view and separated from other, less important lights?
- j. Is the brightness of warning lights compatible with expected ambient illumination levels? (Personnel may not see dim lights in bright sunlight, but bright lights may interfere with dark adaptation.) Are dimmer controls used where necessary?

MIL-HDBK-759B

- k. If operators must monitor a display continuously, but may not always be able to watch it, are there supplementary audible warnings?
- l. Are covers over fuses transparent so personnel can check them without opening the cover or window?
- m. Are indicators color-coded to show normal operating range and danger range?
- n. Are warning circuits designed so they actually sense hazardous conditions rather than merely displaying the control settings?
- o. Are go/no-go or fail-safe circuits used wherever possible to assure that failures will not produce hazards and that operators know when a failure has occurred?
- p. Are discharging (bleeder) devices provided for high-energy capacitors which personnel may touch during maintenance?
- q. Are any exposed dangerous voltages kept separated from internal controls such as switches and adjustment screws?
- r. Are components and live wires that can store dangerous voltages, even when the equipment is off, located where a technician is not likely to touch them accidentally?
- s. Are adjustment screws and commonly replaced parts located away from high-voltage or hot parts?
- t. Are covers, structural members, and similar electrically neutral parts of electrical systems either grounded or protected so personnel and tools cannot touch them?
- u. Are vehicle electrical systems designed to prevent sparking (or other conditions) that could ignite or explode combustible materials?
- v. When tools and equipment are used in an explosive atmosphere, are they non-sparking and explosion-safe?
- w. Are jacking and hoisting points identified clearly, conspicuously, and unambiguously?
- x. Are all liquid, gas, and steam pipelines clearly labeled or coded to identify them and warn of any specific hazards to personnel or equipment?
- y. Do hatches have a positive lock for the open position which is simple to operate yet can withstand all the rigorous requirements of a tactical vehicle in a combat situation?

MIL-HDBK-759B

- z. Are struts and latches provided to keep hinged and sliding components from shifting and thus possibly injuring personnel during maintenance?
- aa. Do drawers and fold-out assemblies have limit stops that keep them from coming out too far, coming loose, or falling?
- bb. Are conspicuous warning notices mounted near high-voltage or very hot equipment?
- cc. When switches or controls initiate hazardous operations (such as ignition or crane moving) are they interlocked so a related or locking control must be released first?
- dd. Are safety interlocks used wherever necessary?
- ee. Are components located and mounted so maintenance personnel have easy access to them without hazards from electrical charges, heat, sharp edges and points, moving parts, and chemical contamination?
- ff. Are mechanical components with heavy springs designed so the springs cannot come loose and injure personnel or damage components?
- gg. Are warning plates provided where mechanical assemblies, linkages, or springs are under constant strain or load?
- hh. When equipment uses internal combustion engines, are the exhausts routed properly to keep carbon monoxide from accumulating in the cab?
- ii. Are exhausts for vans or trailers designed so gases are directed away from the enclosure or compartment?
- jj. Are exhaust pipes of internal combustion engines pointed upward to reduce the danger of igniting flammable liquids which may collect on the ground or floor?
- kk. When equipment may expose personnel to dangerous gases, are warning devices provided to signal when a dangerous concentration is approached?
- ll. Are vehicles and their components made of materials which will not produce hazardous environments under severe operating conditions? (Some materials, such as lead, cadmium, and polytetrafluorethylene liberate toxic gases or liquids when exposed to extremely high temperatures. Other materials may liberate substances which are, or may combine with the atmosphere to become, combustible or corrosive.)

MIL-HDBK-759B

mm. In vehicles, are warning lights provided to alert the driver to fire or excessive heat in areas that they cannot see?

5.8 Systems Applications.

5.8.1 Ammunition.

5.8.1.1 Projectile storage. The term "projectile" in this section is intended to mean a complete round. The ready rack should be designed so that several different types of ammunition can be stowed and removed without shifting other rounds and to minimize interference with the work area. Means should be provided to prevent stowed projectiles from dropping or impacting each other when the vehicle is moving or when the gun is fired. The design should provide for easy stowage/removal of ammunition by hoist or manual means. This should be an easy operation from the rear, side, or front sections of the rack. However, vehicle layout and ammo rack design will determine the requirement for accessibility from the side or horizontal stowage.

5.8.1.1.1 Handling. Particular attention should be devoted to stowing ammunition when manual handling is required so that the gun may be loaded safely, rapidly and effectively. For example, if the rounds are stowed horizontally and parallel to the ramming trough, the soldier loading the weapon may be required to turn around (180°) to place the projectile(s) into the trough. In such cases the projectiles should be stowed with their noses pointing away from the breech so that both loader and projectile are oriented correctly when positioning the rounds in the ramming trough.

5.8.1.2 Projectile transfer. Unobstructed workspace should be provided for transferring the projectiles from outside the vehicle to the ready rack and from the ready rack to the breech. Provisions should also be made for disposing of empty shell cases in vehicles using fixed and semi-fixed ammunition.

5.8.1.2.1 Ammunition hoist. Where an ammunition hoist is used, the projectiles should be prevented from swinging about, thereby endangering personnel or damaging equipment. The ammunition hoist design should include a clamp to prevent accidental release of projectiles, provisions for manual operation of the hoist in case of power failure, and the capability of being stowed without interference with either the ramming trough or breech lock mechanism.

5.8.1.3 Ammunition stowage racks. Ammunition stowage racks, whether loaded or empty, should not impede escape from the crew compartment, obstruct access to controls, obscure displays, or interfere with the footing of crew members and should be located so personnel can remove and replace ammunition from the stowage rack without striking any protrusions.

5.8.1.3.1 Ready racks. Where ready racks are located to the rear of the gun breech, sufficient distance should be provided between the rack and the breech to accommodate the longest round anticipated for use plus the thickness of the 95th percentile gloved hand, and an additional 50 mm channel.

MIL-HDBK-759B

5.8.1.3.2 Floor and hull. Floor and hull stowage tube-type ammunition racks should be spring-loaded so that stowed rounds will travel 50 mm out of the rack when the latching mechanism is released. Where spring-loading is not feasible, the end of the tube should be recessed to facilitate gripping by hand.

5.8.1.3.3 Upright mounts. Upright-mounted ammunition weighing over 18.1 kg should have a floor retainer which has sufficient clearance to allow removal by the 95th percentile gloved hand (see Figure 136).

5.8.1.3.4 Latching mechanisms. Ammunition rack latching mechanisms should be of a quick-release design which requires no more than 53 N to operate, and be free of sharp edges or protrusions which can snag clothing or injure personnel during entrance, exit, and movement within the vehicle. They should remain in the open position or fold out of the way by gravity when unlatched to allow the removal and replacement of ammunition in stowage racks. It should be apparent to personnel when the ammunition rack latching mechanisms are in the locked position but not secured. They should have a cushioning material to minimize transmission of undesired dynamic effects to secured rounds. The mechanism should not allow distortion, bursting or rupturing of the round or cartridge case and should prevent damage to the internal components of the missile/rounds.

5.8.1.4 Fuzes. The surface of hand-manipulated fuze controls should be a material which will maximize the grip the operator can maintain on the fuze. However, the texture of the surface finish should not interfere with the aerodynamic performance of the round.

5.8.1.4.1 Detents. Fixed detents should be used for each position on a fuze so that the moving component of the control will snap into place in the selection of each fuze. Sufficient resistance should be built into the setting to prevent the inadvertent change of settings.

5.8.1.4.2 Pointers. Markings and pointers should contrast maximally with their backgrounds and should correspond in color, if possible. The pointer tip and index should not be separated by more than 1.5 mm.

5.8.1.4.3 Multi -position selectors. The multi-position selectors should be designed to resist changes of operator settings which may result from the rotational force imparted by the round either during firing or while in flight. Designing the selector mechanism so that linear acceleration will lock the selector in place will prevent such accidental changes in setting.

5.8.2 Armament.

5.8.2.1 Primary armament. Main armament loading procedures should be reversible for efficient and safe round removal. In addition, provision should

MIL-HDBK-759B

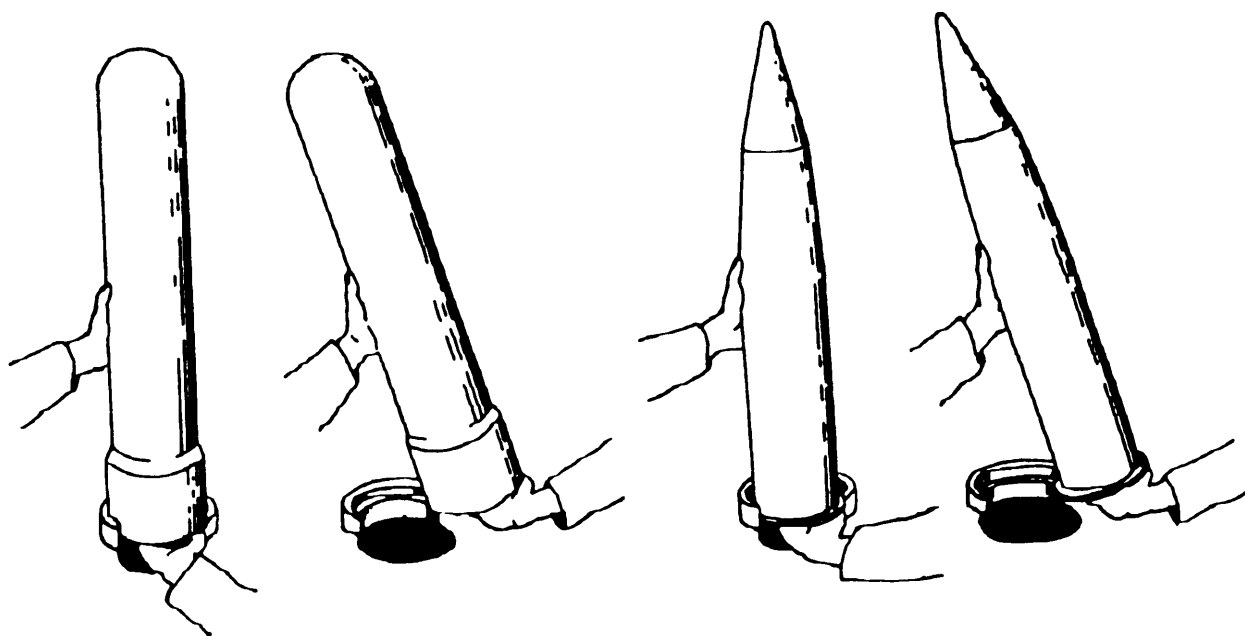
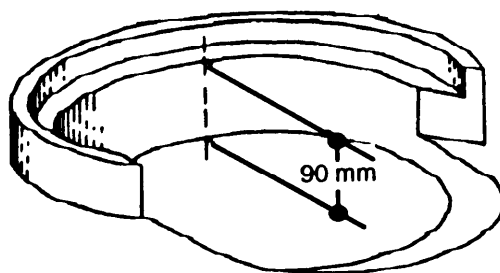

FIGURE 136. Retainers for floor mounted vertical ammunition and missile ready racks

MIL-HDBK-759B

be made to minimize vibration of the gunner's sight from the shock of loading main armament.

5.8.2.1.1 Breech design. A breech weighing over 22.5 kg should not be considered manually removable. For manual breech operation, the operating force should not exceed 130 N for one-handed operation and 220 N for two-handed operations. The controls for power operated breeches should be located away from the breech to protect personnel when the breech is in operation. Stored mechanical energy in the breech block which, if released, could injure the hand, should be protected by interlock from accidental actuation. The main armament recoil mechanism should be capable of being exercised by crew personnel without damage to the system or danger of injury to personnel.

5.8.2.1.2 Maintenance. Main armament machined surfaces should be protected from the environment to minimize maintenance requirements. Crew maintenance of the main armament should not require special tools. In addition, the main armament chamber should be capable of being cleaned by suitably-clothed and -equipped personnel with applicable body dimensions between the 5th and 95th percentile. Servicing polished machine surfaces should not require removing the gun tube. The breech design should provide drains where necessary to preclude trapping cleaning fluids.

5.8.2.1.3 Expended rounds. Casing ejection should not endanger personnel or equipment. Space should be provided to store expended casings within the fighting compartment or a means should be incorporated into the design to allow disposal of these casings by another method.

5.8.2.1.4 Boresighting. Boresighting should be capable of being accomplished by the naked eye and without use of tools from within the fighting compartment and without disassembly in order to achieve the specified convergence with the line of sight or to be parallel with the line of sight. Quadrants and other devices mounted on the main armament should be accessible to the gunner throughout the maximum and minimum elevation and depression.

5.8.2.1.5 Electrical components. The potential of electrical power components should be capable of being de-energized at the primary power source. Shielding should be provided to prevent accidental contact with other wires and electromagnetic pulse. A disconnect capability should be provided at the powered component and power source.

5.8.2.2 Secondary armament.

5.8.2.2.1 Removal and replacement. The secondary weapon should be capable of being mounted on the vehicle by crew members from a natural working position with the weapon fully assembled. This armament should be capable of being removed or replaced without the use of tools. The number of turns required for installing or removing threaded fastening devices should be the minimum required for proper component functioning.

MIL-HDBK-759B

5.8.2.2.1.1 Retaining devices. All secondary armament retaining devices (pins or bolts) should be captive or attached to their mounts by a chain or similar captive device. All retaining pins should be provided with L-shaped handles to expedite their removal under conditions of binding or corrosion. In addition, clamps or similar weapon retaining devices should be hinged to swing away from the mount and should be the quick-disconnect type.

5.8.2.2.2 Ground mount operation. The secondary armament should be capable of being removed and put into the ground mount while hot. The pintle should be capable of remaining attached to the weapon, be designed to position itself by gravity, and should not need to be held by hand when positioned into the ground mount. This would simplify mounting procedures and reduce conversion time.

5.8.2.2.2.1 Sights. For ground mount operation sights, the rear sight notch should be 3 mm or wider and the front sight should be wide enough to fill the notch when taking sight pictures.

5.8.2.2.3 Assembly and disassembly. The secondary armament should be designed in such a manner that barrels are not capable of incorrect assembly and are capable of being changed from the inside of the fighting compartment without affecting the boresight. The design should include spring-loaded retainers, releases, and detents capable of being released by the use of the finger only. The driving rod and spring, or similar kinetic-energy mechanical assemblies, should have a positive release or lock and not be hazardous if accidentally released during servicing. After servicing, the weapon should be capable of being dry-fired without damage to ancillary parts.

5.8.2.2.4 Solenoids. Solenoids should be capable of activating the firing mechanism of the weapon both manually and electrically. When checked electrically, the solenoid should produce an audible click or visual signal to indicate that it is functioning. Solenoids should be adjustable or an adjustment should be provided in the linkage, limiting or compensating for tolerance build-up or have sufficient plunger/armature travel to eliminate the need for adjustment.

5.8.2.2.4.1 Removal and replacement. Removing and replacing solenoids should not require extensive assembly or disassembly of the weapon. In general, wiring and connectors should be easily removable and mounted such that they will not be caught in turret rings or gun breeches. Wiring should be protected against abrading through abuse or striking a surface when personnel are removing, replacing, or servicing the weapon. To guard against disconnection, the solenoid should have an electrical connector designed to eliminate reverse polarity.

5.8.2.2.5 Operation. A weapon should be capable of being loaded without being cocked, but where this is not possible, a positive lock should be provided on the firing mechanism. The weapon should be capable of being loaded by a 5th to 95th percentile hand in both the vehicle and the ground mount. It is desirable to have a weapon that does not require headspace or timing, but where these are required, a simple go/no-go system should be used to determine correct headspace and timing. A

MIL-HDBK-759B

nondestructive feedback is desirable to indicate whether the headspace or timing is correct.

5.8.2.2.5.1 Charging. The weapon should be capable of being charged by suitably-clothed and -equipped user personnel with applicable body dimensions between the 5th and 95th percentile. For ground mount weapons, charging may take place while in the prone position. Where wires or chains are used to charge the weapon, the action of charging should be a nondirectional reaction to an applied force. Straight back pull to charge should not be required. Charging resistance should not exceed 340 N•m breakaway or 80 N•m sustained.

5.8.2.2.5.2 Expended rounds. Expended brass and links should be caught by a spent brass container or be ejected outside the fighting compartment. The trajectory and path of the ejected casings should be such that ejection will not injure a crew member, interfere with crew operations, or affect other equipment. The weapon design should permit removing jammed cases simply and quickly by suitably-clothed and -equipped user personnel with applicable body dimensions between the 5th and 95th percentile without disassembling the weapon and without endangering the hand. If a tool is required, it is desirable to have it mounted to, or be captive to, the weapon on which it is to be used.

5.8.2.2.5.3 Ammo chutes. Flexible ammo-chute openings should be large enough to allow the ammo to be guided through the chute by a 5th to 95th percentile hand and should be free of sharp edges which could cut the hands of personnel during loading operation.

5.8.2.2.5.4 General. Rate selectors, safeties, or triggers should be clearly identified to indicate their position and should be of sufficient size and resistance to accommodate a 5th and 95th percentile arctic-clothed hand. Detents should be provided for each position on rate selectors or safeties.

5.8.2.3 Small arms.

5.8.2.3.1 General. In this section the term "user" will be used to refer to the rifleman or gunner, as appropriate.

- a. Weapons should be designed so suitably-clothed and -equipped user personnel, with applicable body dimensions between the 5th and 95th percentiles, can perform all required tasks (both field operations and maintenance) easily and efficiently in daylight and at night, and in either the standing or prone position.
- b. When the user must reassemble parts under field conditions, their mating surfaces should be beveled to simplify assembly.
- c. Surfaces of the weapon or its attachments that normally contact the user's body or clothing during firing or maneuvering should be smooth, without sharp edges or discontinuities.

MIL-HDBK-759B

- d. Any part of the weapon or attachments that contacts the user's skin should have thermal insulation.
- e. Weapon design should minimize projections that could impede movement through dense vegetation. Unavoidable projections (such as the front sight post) should be angled toward the back of the weapon rather than perpendicular to its barrel.
- f. A weapon's controls or latches should be designed and located so they will not be operated unintentionally during fire or maneuver.
- g. Weapons should be designed so users will not damage them by operating controls in the wrong sequence or by using full hand force.
- h. Weapons should be designed so parts cannot be assembled improperly.
- i. Weapon controls should be sufficiently sturdy and durable to prevent damage from normal handling in the field.
- j. Whenever the user is likely to remove retaining pins during field operations or maintenance, captive hardware should be used to prevent pin loss.
- k. A weapon's safety should be located so the user can change from SAFE to FIRE (and vice versa) quickly, without moving either hand from its normal firing position.
- l. Weapon controls should have distinctive shapes and locations to simplify their identification and use during stressful situations.
- m. Safety should be designed into weapons by assuring that no part of the weapon:
 - (1) could endanger the user's face during firing if the head is held in the proper eye-sight position, and
 - (2) encourages the users to fire their weapon in an unorthodox way that might cause injuries.

5.8.2.3.2 Rifles and machine guns.

- a. Figure 137 shows an acceptable range of dimensions for rifles and machine guns.
- b. The charging handle should not interfere with the bolt during firing.
- c. Magazines should be designed so that:

MIL-HDBK-759B

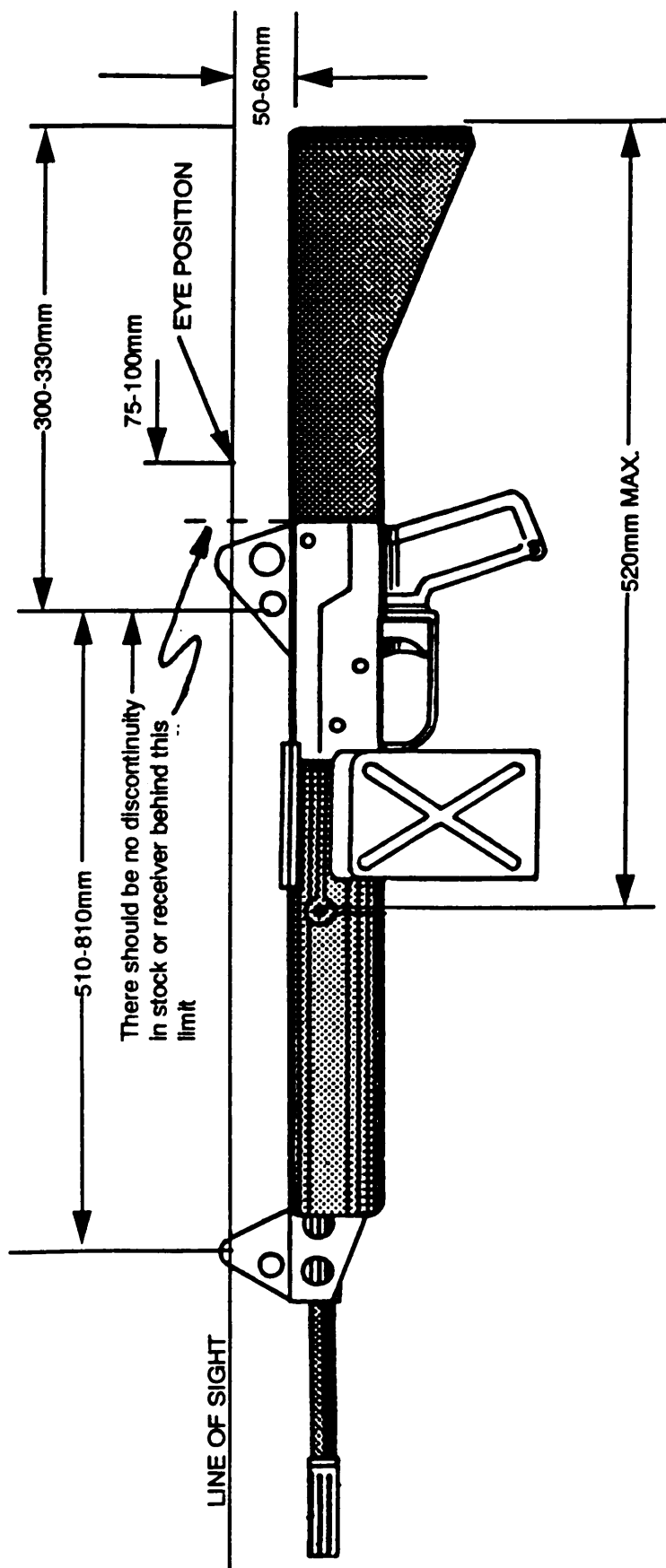

FIGURE 137. Dimensions guidance, rifle and machine guns

MIL-HDBK-759B

- (1) they can only be loaded correctly (not with miteridges facing the wrong way);
 - (2) they can be held with one hand, and have a non-slip finish on surfaces the user will hold during all handling operations;
 - (3) loading requires only inserting the magazine and charging the weapon (but no additional human tasks); and
 - (4) a particular loading pattern is not required; however, where this is unavoidable, a magazine loading diagram should be provided.
- d. When a biped is used, it should be designed so that:
- (1) the user wearing arctic mittens can extend or retract the biped easily and quickly;
 - (2) recoil and stresses of field maneuvering will not disturb the biped's extended or retracted setting;
 - (3) with biped retracted, the user should be able to grasp the foregrip without obstruction, in either the prone or standing assault position. In addition, the biped should accommodate uneven terrain without cant; and
 - (4) when attached to the weapon, but retracted, the biped should not tangle with vegetation.
- e. The rear sight should be designed so that:
- (1) all component parts are positively retained;
 - (2) the rear aperture and other parts remain secure during the stresses of carrying and firing;
 - (3) windage and elevation controls have detents to prevent disturbing of settings as a result of combat stresses of carrying and firing;
 - (4) the design should allow the user wearing arctic mittens to set windage and elevation controls quickly, easily, and precisely, without tools;
 - (5) windage and elevation controls can be clearly differentiated to minimize confusion;

MIL-HDBK-759B

- (6) windage and elevation control settings are immediately obvious, in daylight, when the user is in any normal firing position; and
 - (7) the user, when in a normal firing position, is able to verify setting quickly without moving the body or the weapon, manipulating any sight component, counting, or requiring visual or auditory cues.
- f. Weapons should eject expended cases into the first quadrant (forward and to the right).

5.8.3 Communications.

5.8.3.1 General. Voice communication is the most common method of requesting and providing information. In military systems, information may be transmitted by using radio or telephone or from operator to operator. Electrically transmitted speech depends, to a great extent, on the characteristics of the microphone, transmission equipment, and the reception equipment; however, both direct and electrically transmitted communications have certain limitations in common. One of the limitations is the acoustical environment of both the speaker and listener, and this factor is of great importance in determining communication effectiveness. Communication equipment should be located to ensure the maximum intelligibility in the area served.

5.8.3.1.1 Masking of speech by noise. Most of the energy required for near-perfect speech intelligibility is contained in the range of 200-6,100 Hz. This range may be narrowed to 250-4,000 Hz without significant loss in intelligibility. Consonants contain energy mainly at frequencies above 1,500 Hz, whereas vowels contain lower-frequency energy. Unfortunately, the consonants, which convey most of the information in English speech, contain very little energy. Thus, they are more subject to interference (masking) from noise than are vowels. Vowels contain more energy but transmit less information.

5.8.3.1.2 Power. The communication system should be capable of power output at least 15 dB louder than the anticipated ambient noise. The user should have a gain control for adjusting the output level. Output sound pressure level should not exceed 105 dB peak voice level at the ear, but where appropriate, average level may be increased by using peak clipping, compression, or automatic volume control.

5.8.3.1.3 Audible signals. When two or more items of communication equipment with audible signals (telephone, radio, and intercom) are in the same area, each should have a distinct signal.

5.8.3.2 Telephone. A telephone should be used when messages are from one person to another person, ambient noise is too high (more than 75 dB(A), or

MIL-HDBK-759B

exceeding NC-55) for a loudspeaker system, and security of communication is a requirement. If the operator is in a fixed position with hands free, a handset should be used; if the operator's task requires using both hands, a headset should be used, and if the operator must be mobile within a limited area, a headset and extension cord should be used.

5.8.3.3 Loudspeaker (announcing system or intercom]. An announcing system or intercom may be used when:

- a. the ambient noise level is low;
- b. it is desirable to transmit to several stations simultaneously;
- c. it is desirable for several persons within a space to receive simultaneous y;
and
- d. the listener must move about within a space, and a headset would be an impediment.

5.8.3.4 Receiver and headset. The receiver and headset should have a frequency response of +/- 3 dB between 300 and 4,500 Hz to maximize intelligibility.

5.8.3.4.1 Warning signals. Auditory warning signals should be presented through the operator's headset as well as to the work area when ambient noise level will exceed 85 dB(A) or when the operator will ordinarily wear earphones covering both ears during normal equipment operation.

5.8.3.4.2 Miscellaneous. Headset jacks or connectors should be placed so the headset cord will not obstruct the work area or interfere with the operator's normal functions. If listeners wear headsets while working in high ambient noise (85 dB(A) or above), headsets should cover both ears, and their attenuation qualities should be capable of reducing the ambient noise level to less than 85 dB(A).

5.8.3.5 Talkers. Supervisory personnel may sometimes be required to maintain communications on (or monitor) more than one circuit at a time. These personnel should be assisted by a talker who can monitor and repeat messages on the major or the more important circuit, as assigned. The talker's duties are passing on outgoing messages and repeating incoming ones. The supervisor or equipment operator should have a talker if they receive messages simultaneously on different channels, receive so many messages on a single channel that they distract from another task(s), or move often enough, or far enough, that it becomes impractical to use extension cords.

5.8.3.6 Radio set. The radio set should be located where normal system operations and crew activities are not likely to damage it. Such locations should also minimize interference with the crew's normal range of movement and eliminate hazards to them. However, radio control panels should be readily visible and accessible to operators. The operator should also be able to reach control panel(s) to change frequency without having to open doors or remove covers. When protective

MIL-HDBK-759B

devices such as fuses and circuit breakers are located inside the equipment, there should be a visible status indicator where the operator can see it.

5.8.3.6.1 Safety. All external metal parts which operators ordinarily touch should be at ground potential. There should be a provision for discharging high-voltage circuits and capacitors to 30 volts within two seconds before maintenance personnel work on them. In addition, if components in a high-voltage circuit have exposed terminals, they should be protected so that operating and maintenance personnel cannot short circuit, ground, or contact them accidentally.

5.8.3.7 Radio antenna. Locations for radio antennas should be selected to minimize the possibility of radio frequency hazards to personnel. Antennas and waveguides should be at ground potential, except for the radio frequency energy meant to be radiated.

5.8.3.8 Control box. Control box locations should be chosen so that operators have easy access to controls. The boxes themselves should not interfere with the operator's normal movements or present any hazard to them. It is important that the boxes not be placed where they are likely to be used as footrests or steps. Any cables connected to headsets or microphones should be clear of rotating or moving linkages. Boxes should be within easy reach of standard connecting cables (760 mm) from the crewman's nominal working area. If warning lights are mounted on the control box, they should be located within the responsible crewman's field of vision (see Figure 26).

5.8.3.9 Audio accessories. Stowage hooks should be provided in each crew member's normal working area for storing audio accessories such as microphones, headsets, handsets, and cords when they are not in use. However, these hooks should be located where they will neither obstruct the operator's normal movements nor be likely to cause injury when equipment is removed from stowed positions.

5.8.3.10 Cable routing. All interconnecting cables should be routed neatly (clamped at approximately 300 mm intervals) to eliminate droop and unnecessary loops so that personnel are not apt to use them as handholds or steps. If this is not feasible, cables should be covered by protective guards.

5.8.4 Equipment subsystems (vehicular).

5.8.4.1 Batteries.

5.8.4.1.1 Battery compartments. Batteries should be located away from sources of heat and be environmentally protected to ensure satisfactory functioning within all ambient temperature ranges. Adequate compartment space should be provided around the batteries for the placement of insulation or heating pads when winterizing the equipment.

5.8.4.1.1.1 HOLDERS. Battery holders should be rugged and have easily operated (without tools) clamping devices to firmly hold the battery in position against all vibration, vehicle motions, and gunfire shocks.

MIL-HDBK-759B

5.8.4 .1.1.2 Mounting racks. Under-the-hood mounting racks for batteries should be placed within the 5th percentile operator's reach, with the hood open. If such access is not feasible, corrosion resistant roll-out racks (or similar devices) should be provided.

5.8.4 .1.1.3 Ventilation. Batteries should be located in well ventilated areas (particularly when being charged) since they may emit hazardous concentrations of toxic or explosive gas and threaten the health and safety of personnel in the area. In areas where batteries are stored, it is recommended that appropriate warning signs be posted which read "NO SMOKING", "DANGER, NOXIOUS FUMES AREA," or "NO OPEN FLAME."

5.8.4.1.1.4 Partitions. Whenever both the battery and the fuel tank are under the driver's seat, they should be partitioned from each other and both compartments should have separate covers, ventilation, and drainage to the outside.

5.8.4.1.1.5 Receptacles. When a slave receptacle is required, it should be installed on the exterior of the vehicle (or equipment) as near as possible to the battery enclosure. It should be accessible from ground level to all Army personnel. It should also be located away from areas where fuel or other explosive vapors are present.

5.8.4.1.2 Battery servicing. Battery access covers should be fastened with quick-release fasteners and insulated on the inside of the cover to prevent cable shorting if accidentally loosened. It should be readily apparent if the access cover is either loose or secure. If the cover is hinged, there should be enough clearance to open the cover.

5.8.4.1.2.1 Access. Complete freedom of access for replenishing the electrolyte, seeing into the filler opening, and testing the specific gravity and voltage should be provided. Use of loose filler caps should be avoided whenever possible.

5.8.4.1.2.2 Maintenance. Batteries and their compartments should be designed so they can be cleaned and serviced without removing any other components. Batteries should be capable of rapid and easy removal by one person for servicing or replacement without removing other items of equipment or without requiring special tools.

5.8.4.1.3 Battery acid. Battery supports, holddowns, and areas around the installation which could possibly be affected by dripping or seepage of acids should be protected with acid-proof paints or coatings. Battery cases should be drained overboard with acid-proof piping when required.

5.8.4.1.4 Cables. Wherever the starter cable passes through a metal part, it should be insulated with a acid-proof and waterproof bushing to prevent grounding.

MIL-HDBK-759B

5.8.4.1.5 Battery terminals. To prevent incorrect connections, the battery's positive and negative terminals should be correctly labeled and should also be easily identifiable by being shaped or sized differently. Dust caps should be provided so that terminals cannot contact metal surfaces during handling, removal or replacement.

5.8.4.2 Brakes.

5.8.4.2.1 Implication of brakes. There should be two independent means available to the operator for applying vehicle brakes. One such means should be an auxiliary parking brake. If the two brake systems are not completely independent, the design of the system should be such as not to degrade one braking system should the other system fail.

5.8.4.2.1.1 Air brakes. The design of air or vacuum braking systems for any surface vehicle should provide full braking capability with or without the engine operating.

5.8.4.2.1.2 Towed vehicles. Every vehicle used to tow another vehicle with full air brakes should have a means of activating the towed vehicle's brakes.

5.8.4.2.1.3 Parking brake controls. Manual parking brake controls for trailers should be located so that an operator can reach them easily after positioning or parking the trailer. The controls should not be located on the side of the vehicle normally exposed to road traffic.

5.8.4.2.2 Brake warning.

5.8.4.2.2.1 Air brakes. Vehicles with compressed air brakes should have warning signals that operate continuously as long as pressure is below a fixed threshold level (not less than one-half the cut-out pressure of the compressor governor). These warnings should be designed so they are audible or visible to the operator. In addition, each vehicle should have a pressure gauge which indicates the braking pressure (pascals).

5.8.4.2.2.2 Vacuum brakes. Vehicles with vacuum brakes should have an audible or visible warning signal which gives a continuous warning as long as the vacuum in the supply reservoir is less than 200 mm of mercury. In addition, each vehicle should have a vacuum gauge indicating the braking vacuum in appropriate units.

5.8.4.2.3 Brake maintenance. All parts of the brake assembly, drums, discs, shoes, cylinders, support plates, and housing mechanisms should be quickly and easily removable, renewable, and repairable. Appropriate inspection ports, protected by a window or removable cover, should be provided to permit examination of brake linings. Brake system components requiring maintenance action should be both visible and accessible to maintenance personnel.

MIL-HDBK-759B

5.8.4.2.3.1 Accessibility. Rapid accessibility should be provided for such operations as filling, bleeding, and adjusting the brakes. All connections for air, vacuum, or non-flammable hydraulic fluid braking systems should be accessible to the operator. The air reservoir drains, master cylinder, and other such components should be easily accessible for servicing. Brake tubing and hoses should be mounted so that fittings are accessible with ordinary hand tools.

5.8.4.2.3.2 Glad hands. Where service and emergency air brake components are installed on the front or rear of equipment, the glad hands should be rigidly mounted with service glad hand on the curb side and emergency glad hand on the road side. Each glad hand should be equipped with permanent and clear identification tags. A spring-type, metal dust cover should be installed on each glad hand to prevent contaminants from entering the opening. Color coding, when specified, should be blue for service and red for emergency.

5.8.4.2.3.3 Check valves. Every air or vacuum reservoir should have a check valve so that leakage from the air or vacuum supply lines will not deplete the reservoir. Means should be provided to determine that the check valve is in working order.

5.8.4.2.4 Brake adjustment.

5.8.4.2.4.1 Special tools. Brakes should be adjustable without using special tools (including wheel pullers) or removal of any part. Adjustments required to tighten brakes should be clearly marked as to proper rotation or action when operation is not obvious.

5.8.4.2.4.2 Self-adjusting brakes. Self-adjusting brakes are both a desirable and acceptable design feature provided that brake adjustment cannot be changed inadvertently and that actual brake system data prove the self-adjustment system to be effective.

5.8.4.3 Clutches.

5.8.4.3.1 Split line. Whenever possible split-line clutch element design or other appropriate methods should be used so that clutch linings, plates, or discs can be rapidly removed and replaced without removing other power-train components such as the engine and associated gear box.

5.8.4.3.2 Thrust bearings. Thrust bearings should be replaceable by use of split-line design or other appropriate method without removal of any major part of the equipment.

5.8.4.3.3 Dry type. Dry type clutch design should provide generous positive slingers, designed to prevent oil leakage from coming in contact with the surface of the clutch.

MIL-HDBK-759B

5.8.4.3.4 Other features. Well-guarded drain holes and baffles should be provided to prevent any oil from collecting on the clutch face. Any clutch adjustment devices which are provided should include a feature for indicating the amount of clutch lining remaining following each adjustment.

5.8.4.4 Fuel system.

5.8.4.4.1 General. The following should be included in the consideration of general fuel system design.

The capacity of the fuel tank should be clearly marked on the tank.

Tactical and combat vehicles' fuel tanks that hold 190 liters or more should be able to accept fuel at 190 liters per minute. Tanks that hold less than 190 liters should accept fuel fast enough to be filled in one minute.

The fuel tank drain plug should be located so that the fuel tank can be drained completely. Personnel should be able to remove the drain plug with on-equipment material (OEM).

Fuel filters that are accessible and easy to clean should be provided.

The replacement of fuel feed pumps should be accomplished as simply as any other roadside repair. If this is not possible, an alternate fuel supply system should be considered.

The fuel system should be constructed so gravity or siphoning cannot feed fuel directly to the carburetor or injector.

The operator should be able to remove the air intake pipe on the carburetor easily.

5.8.4.4.2 Safety. Safety features of tanks for liquid fuels are listed below.

- a. As a precaution, in case of collision, the vehicle's fuel tank should not be forward of the front axle.
- b. The fuel tank and fuel filler pipe should not be inside or over parts of the vehicle that carry the crew or passengers.
- c. The tank, its intake pipe, or its supports should not project beyond the vehicle's overall width. Ideally, these components should be located slightly inward of the overall width.
- d. The tank should be designed so that if the vehicle turns over, fuel will not spill out faster than 30 ml per minute.

MIL-HDBK-759B

- e. When fuel is forced from the tank with pressure devices, there should be a safeguard (excess-flow valve) to stop the flow of fuel if the fuel feed line breaks.
- f. Every fuel tank should have a non-spill air vent. It may be mounted separately, or combined with the filler cap, and should be above water during vehicle swimming operations.
- g. The nozzle opening in the fuel fill pipe should be located to minimize the likelihood of spilling fuel on the exhaust system, the battery, or inside the vehicle. It should never be more than 1.2 m above the ground or more than 1.2 m above the base of the work platform used for refueling.

5.8.4.5 Engine.

5.8.4.5.1 Accessibility. Engine designs should provide easy access for maintenance.

5.8.4.5.1.1 Engine accessories. Fuel and coolant pumps, starter motors, generators, filters, and other engine accessories should be accessible without removing the engine from the vehicle. It should be possible to replace any engine accessory without removing more than one other engine accessory. Fuel and oil filters should be located where they can be cleaned and replaced without disassembling the engine from the chassis and without first removing engine accessories such as starters, generators, pumps, or manifolds.

5.8.4.5.1.2 Filters and belts. Air cleaners should be located where they are easy to remove, service and install using OEM tools and equipment. Crankcase sumps should be easy to remove. Fan belts and other drives that require adjustment should be designed to be handled while wearing arctic mittens and so located to provide easy, safe access away from heat sources such as hot manifolds.

5.8.4.5.1.3 Spark plugs. Spark plugs should be accessible. They should be removable with OEM tools and equipment. Ignition system wiring should be mounted and routed so vehicle vibration or personnel movements cannot break connections accidentally.

5.8.4.5.1.4 Engine timing marks. Engine timing marks should be easily visible and should have a visible reference point on the engine, so that the timing can be checked when the engine is installed in the vehicle.

5.8.4.5.2 Drains. Engines that use diesel or multi-fuels should be designed so that it is easy to drain the primary fuel filter daily. Drains should be located to direct their flow onto the ground, rather than on equipment. Removing oil-drain plugs should allow the pan to drain completely if the vehicle is on a level surface.

MIL-HDBK-759B

5.8.4.5.3 Throttles. Engines used as electric or pneumatic power sources and vehicular engines on radio-carrying vehicles should have a tachometer and throttles which can be locked at selected part throttle positions. Vehicles should be equipped with overspeed governors which are tamper-proof.

5.8.4.5.4 Air restriction gauge. If an air restriction gauge is required it should be placed where it is visible to the operator of the vehicle.

5.8.4.6 Radiators.

5.8.4.6.1 General. The radiator filler neck should be large enough to accept existing filler nozzles. It should be positioned so that the operator can see the fluid level inside the radiator. There should be an accessible drain in the radiator's lower tank to drain it completely onto the ground or into a suitable container without splashing on vehicle parts. A guard should be provided to protect the radiator during travel through brush and during actions. It should be possible to remove the radiator without removing the engine.

5.8.4.6.2 Tubes and hoses. Radiator coolant tubing and hoses should be designed, constructed, and installed to ensure continued functioning in all environments. They should be sufficiently long and flexible to accommodate all normal motions of the parts to which they are attached without damage. They should be secure from chafing, kinking, or other damage. They should be mounted with airplane-type clamps which are accessible to the operator.

5.8.4.7 Exhaust systems.

5.8.4.7.1 Location. The exhaust system should be located or protected so that personnel will not come into contact with hot surfaces. The design should keep fumes from entering crew and other personnel compartments. Exhaust gases should be deflected away from tires, roadways, and the ground so as not to damage vehicle components, disturb roadway dust or cause brush or grass fires. In addition, the exhaust system should not be capable of being clogged or its function degraded when the vehicle is either operating on a muddy surface or engaged in swimming operations.

5.8.4.7.2 Drains. Gravity draining of the exhaust system should be provided so that it will drain completely when the vehicle is on level ground.

5.8.4.7.3 Mounting. The system should be mounted to the chassis securely, yet loosely enough so that flexing between components will not cause damage. No part of the exhaust system should cause burning, charring, or other damage to the vehicles electrical wiring, the fuel supply, or any other equipment.

5.8.4.7.4 Mufflers. The exhaust system should include mufflers (silencers) to limit the noise to which any occupant is exposed to the levels specified in the current issue of MIL-STD-1474.

MIL-HDBK-759B

5.8.4.8 Drains and vents.

5.8.4.8.1 General. Drain valves should be accessible, dependable, and have simple operating mechanisms. Drains that purge pneumatic-system reservoirs should be readily accessible and should drain the tanks completely. Drains and vents should be located where crew members can clear and check them easily. They should be easy to identify and to close and check before fording or swimming operations. Instruction plates giving drain and vent locations and procedures for operating them should be provided. Vehicles that swim should be equipped with bilge pumps.

5.8.4.8.2 Design. Vents should be designed so that mud, ice, or other foreign matter will not clog them. Drain plugs and valves should be designed to resist seizing in either the open or closed positions. All drain plugs should be the same size. If drain plugs cannot be designed to be the same size the number of different sizes should be minimized.

5.8.4.8.3 Fluids. Drains should be designed so as to empty lubricants and hydraulic fluids completely onto the ground or into a suitable container. Fluids should drain to the outside of the vehicle, without falling on obstructions or splashing onto vehicle components.

5.8.4.8.4 Mounting. Regardless of whether they are open or closed, drains in the vehicle should remain flush to the surface in which they are mounted so they do not interfere with the loading, stowage, or unloading of cargo.

5.8.4.9 Filling, draining, and checking procedures.

5.8.4.9.1 Dipsticks. Items such as the engine, transmission, and hydraulic reservoir sumps should be equipped with dipsticks to determine fluid levels. Dipsticks should be etched, sandblasted, knurled, or phosphate-coated to facilitate determination of the fluid level. Other items such as gear cases, differentials, and reservoirs which contain oil should be equipped with either dipsticks, check plugs, or sight glasses, as appropriate. Each pump enclosure should be fastened within the housing.

5.8.4.9.2 Drainage. Removal of drain plugs should result in complete drainage of the fluid from each sump or enclosure. When equipment or a vehicle is in a level position, drainage of all fluids, including engine coolant, should be onto the ground, or into a suitable container without damage to any part of the equipment. Integral tubes, hoses, or troughs may be utilized to convey these fluids from the drains.

5.8.4.9.3 Accessibility. Access to the filling means, the fluid-level checking means, and the drain plugs and valves of all sumps, enclosures, reservoirs and radiators should be provided without removal or adjustment of components or parts other than access covers.

MIL-HDBK-759B

5.8.4.10 Chassis.

5.8.4.10.1 General. Cabs and bodies should be easy to remove. Heavy cabs should be provided with lifting points, which are properly marked (LIFT HERE). The skirting plates, track guards, and mud flaps should be easy to remove and be capable of preventing rocks and other debris from being thrown against the crew, passengers, or other personnel in the immediate vicinity. Suspension units and final drives should be removable under field conditions. Replacement parts should be bolted, not riveted or welded, to the frame.

5.8.4.10.2 Alignment. Standard devices for checking chassis alignment should be provided at accessible positions and should be suitably marked. The installation and adjustment of tracks should not require the use of special jacks or tensioners to pull out slack in the track.

5.8.4.10.3 Bumpers. Bumpers should be of standard proportions, located at standard height within the vehicle class, and be rugged and sufficiently strong for towing with the vehicle loaded. Appropriate towing attachments should be provided on the bumper.

5.8.4.10.4 Accessibility. Hoods and other access panels which must be opened for daily checks should be accessible and operable by a single 5th percentile operator.

5.8.4.11 Intravehicular coupling device.

5.8.4.11.1 General. Coupling devices should be long enough so that they do not restrict the towing vehicles' maneuverability during towing operations. Coupling devices should be designed to preclude mismating and damage under normal use. Suitable measures should be employed to protect intravehicular couplings from accidental disconnection, kinking, entanglement, dragging, abrasion, or pinching during operation.

5.8.4.11.2 Features for air and hydraulic brakes. Air and hydraulic brakes should include the features listed below.

- a. Vehicles with air-over-hydraulic brakes or air brakes, should have provisions at the front and rear for connecting to another vehicle's brake system and controlling it during towing operations.
- b. Vehicular air brake hoses and hydraulic hoses should be identified clearly at each end.
- c. Safety chains should not cause damage to, or disconnection of air, hydraulic, or electrical cables.

5.8.4.12 Spare tires.

5.8.4.12.1 General. The spare tire and the tools for servicing it should be readily accessible. A 5th percentile woman in size and strength should be able to jack up the

MIL-HDBK-759B

vehicle, remove the spare tire, remove the damaged tire, install the spare tire, tighten the nuts to the required torque to secure the spare, and stow and secure the damaged tire using OEM equipment. Equipment for stowing and removing the spare tires should be simple to operate and safe to use. It should be possible to remove and replace the spare tire with the vehicle fully loaded.

5.8.4.12.2 No spare tire criteria. When there is no spare tire, the vehicle should have a “limp home” device (to temporarily take on the function of the damaged tire) that will permit it to continue traveling for 80 km after the failure.

5.8.4.12.3 Air-over-hydraulic brake systems. Vehicles with air-over-hydraulic brake systems should have a pneumatic outlet and OEM pressure gauge for adjusting tire pressures. The air hose for this outlet should be long enough to reach all the tires, including the spare, from the air compressor on the same vehicle or another vehicle. It should be possible to inflate and check the spare tire with a standard air gauge without removing the spare from its mount.

5.8.4.12.4 Dual-wheels. Dual-wheel tires should be designed so both outer and inner tires can be inflated and checked. Valves should be located so tires can be inflated and checked when they are interchanged.

5.8.4.13 Ladders for trailers and vans.

5.8.4.13.1 General. Ladders should be used whenever personnel have to change elevation abruptly (more than 400 mm) during operation or maintenance of the vehicle. Surfaces upon which personnel step or walk should be non-skid (expanded metal) and be of sufficient length and width to accommodate arctic boots. Ladders should lock in place during use and have no obstructions, edges, notches or burrs which could injure personnel or damage hoses or cables. Markings should be provided indicating any dangers associated with their use (low overhead or possible shock). Wherever possible, ladders should be capable of being carried, handled, and positioned by one person, but should never require more than two.

5.8.4.13.2 Design considerations. The designer should take into consideration spatial limitations and clearances, weather conditions affecting a ladder's use (rain, ice, snow) and traffic flow. Hinges and locks are preferable to bolts and nuts for assembling two-section extension ladders, and catches and other mechanisms on folding ladders should be kept as simple as possible. When operational vans will remain in one place for an extended period of time, stair ladders should be used.

5.8.4.13.3 Selection. Ladder selection should be based on the required structural strength of the ladder relative to the required slope of the ladder. Figure 67 shows the preferred and critical angles of inclination for various ladders. Ladders should be designed to support the weight of a 95th percentile man dressed in arctic clothing plus the weight of any additional equipment that he may be wearing or carrying (approximately 113 kg). Dimensions for stair ladders, fixed ladders, and stairs are shown in Figures 68, 71, and 72. If one person must lift and stow a ladder manually, the ladder's weight and lift distance from ground level should not exceed 11.3 kg for 1.52 m, or 9 kg for 1.83 m.

MIL-HDBK-759B

5.8.4.14 Canvas and accessories. The cab of a vehicle should be designed so that one member of the crew can convert it from open to closed configuration and vice versa in 10 minutes or less. Tarpaulins, end curtains, and bows also should be designed so that two crew members can remove or install them in 10 minutes or less. These times do not apply to heavy padded arctic cabs and enclosures. One crew member should be able to gain access to the cargo compartment within three minutes, from front or rear, with the tarpaulin and curtains in place. Pins and other retaining devices should be designed so two crew members, wearing triggerfinger mittens, can remove and replace them.

5.8.4.14.1 Cargo vehicles. When cargo vehicles are used for troop transport or workspace, there should be between 1.5 and 1.9 m of clearance between the tarpaulins and bows covering the bed and cargo floor. Tarpaulin bows and ropes should be easy to unfasten. Bows should be designed so that personnel wearing gloves can remove them from sockets under wet, muddy, or freezing conditions. Tarpaulin and cab-top bow sockets should have adequate drain apertures. Cab-tops, tarpaulins, and curtains should be protected from chafing and flapping. Tarpaulins and end curtains should be fire resistant. There should be a provision for rolling up the sides of cargo area tarpaulins to ventilate the area occupied by soldiers.

5.8.4.14.2 Other features. Pins and other retaining devices should have the maximum working clearances that still assure they will be retained properly. Chains should be used with retaining pins and other similar devices to prevent loss of these items. There should be space to stow stakes and bows on the vehicle. Vehicles that transport troops should have safety straps at the rear of the vehicle.

5.8.4.15 Horns. Where horns are required, they should produce complex sound in the audio frequency band between approximately 250 and 2,000 Hz. The sound pressure level between these frequency limits, measured 915 mm from the exit of the horn and on its axis, should be between 100 to 120 dB(A). Sound level should be measured with the horn installed on the vehicle. There should not be any reflecting wall or obstacles (other than the ground) within 30.5 m of the horn when its sound level is measured. Sound measurement should be made with instruments that comply with the latest version of American National Standards Institute Z 24.3.

5.8.4.16. Heaters.

5.8.4.16.1 Exhausts. Any heater that uses oil, gas, liquified petroleum gas, or any other combustible fuel for its operation, should discharge its exhaust products outside of the vehicle.

MIL-HDBK-759B

5.8.4.16.2 Location. Heaters should be located or protected so that personnel cannot touch parts that are hot enough to cause burns (46°C). The heater air inlet should be positioned so it cannot ingest either engine or heater exhaust gases.

5.8.4.16.3 Mounting. Van heaters should be fastened securely so they will stay in place during normal use or in case the vehicle overturns. They should be designed so that they will not come apart, exposing parts (exhaust stacks, pipes or conduits) if the vehicle overturns. It should be possible to replace igniters, resistors, and other "high-mortality" items without having to remove the heater from the vehicle. Cab heater controls should be accessible to the operator and assistant operator.

5.8.4.16.4 Other information. See 5.4.2 for heating and ventilation requirements.

5.8.4.17 Seating.

5.8.4.17.1 General. Seating for vehicle operators should follow the dimensions recommended in Figures 138 and 139, and Table 72. See 5.8.5 for seating data for specific crew stations. The seat pan should be kept to a minimum, but the seat padding should be resilient enough to keep the operator's body from contacting the seat bottom when experiencing maximum vertical accelerations. Seat padding made from foam-type material should be adequately ventilated.

5.8.4.17.2 Lumbar area support. If only the lumbar area is supported, the backrest angle should be 93° to 103° for operators in an alert position. The backrest angle should not be more than 105° from horizontal (see Figure 138).

5.8.4.17.3 Adjustments. If the seat height above the floor is variable, leg room and footrest criteria will also vary. When the seat is adjusted higher, there will be more leg room and larger footrest areas. Seats should adjust a minimum of 150 mm in the fore-aft direction.

5.8.4.17.4 Dynamic forces. A seat should provide security from dynamic forces which tend to "unseat" a person. Slightly contoured sides on the seat pan is one means of securing against mild dynamic influences. For more violent motions, restraint systems such as waist and shoulder harnesses should be provided.

5.8.4.18 Lighting system.

5.8.4.18.1 General. The lighting system found in military vehicles and equipment usually consists of:

- a. headlights to illuminate the road ahead of the vehicle/equipment,
- b. parking and side lights to indicate the location of the vehicle/equipment,

MIL-HDBK-759B

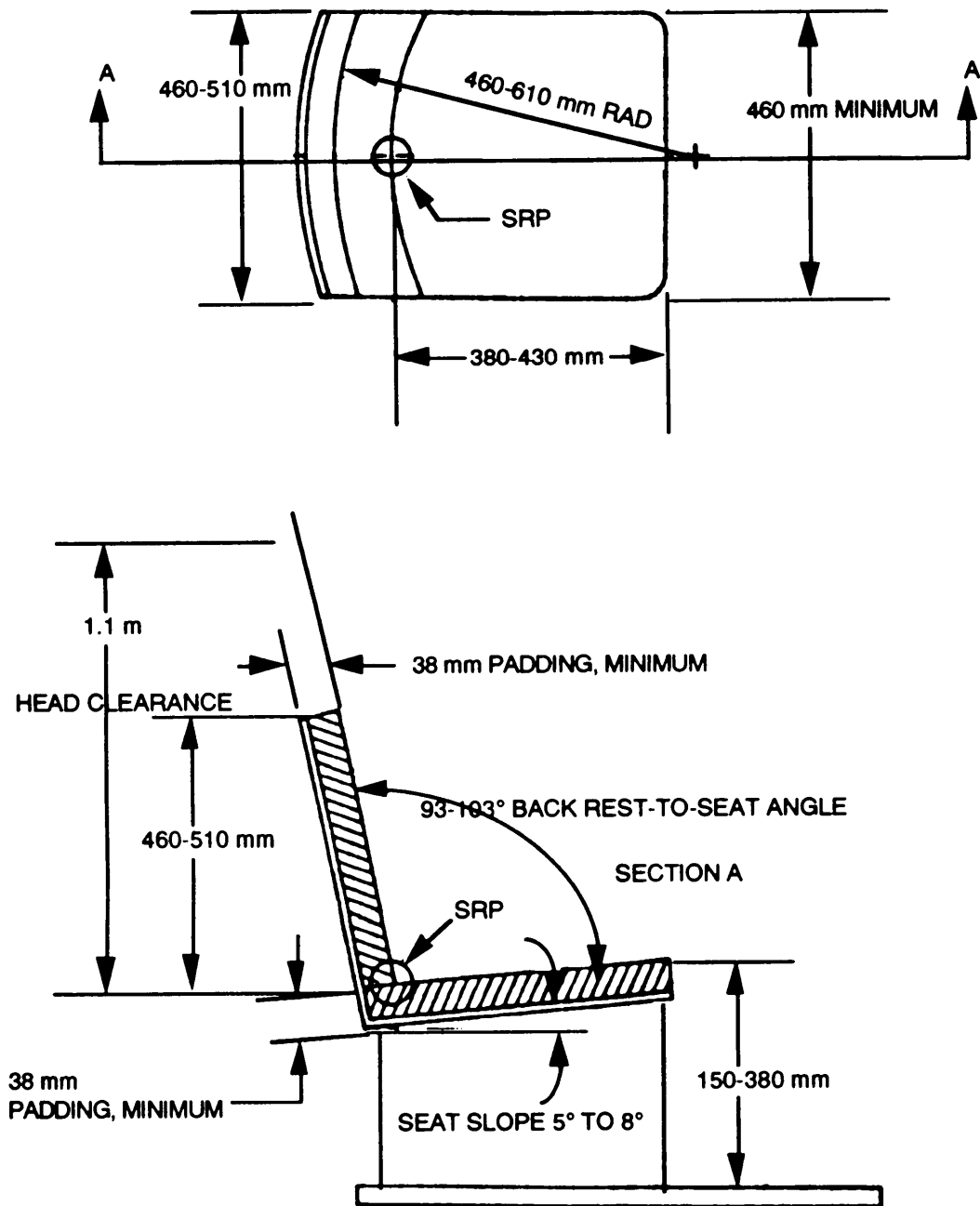

Seat reference point (SRP) is a point where seat back (depressed) and seat cushion intersect.

FIGURE 138. Dimensions for vehicle operator's seat

MIL-HDBK-759B

This Page Intentionally Left Blank.

MIL-HDBK-759B

A. OVERVIEW

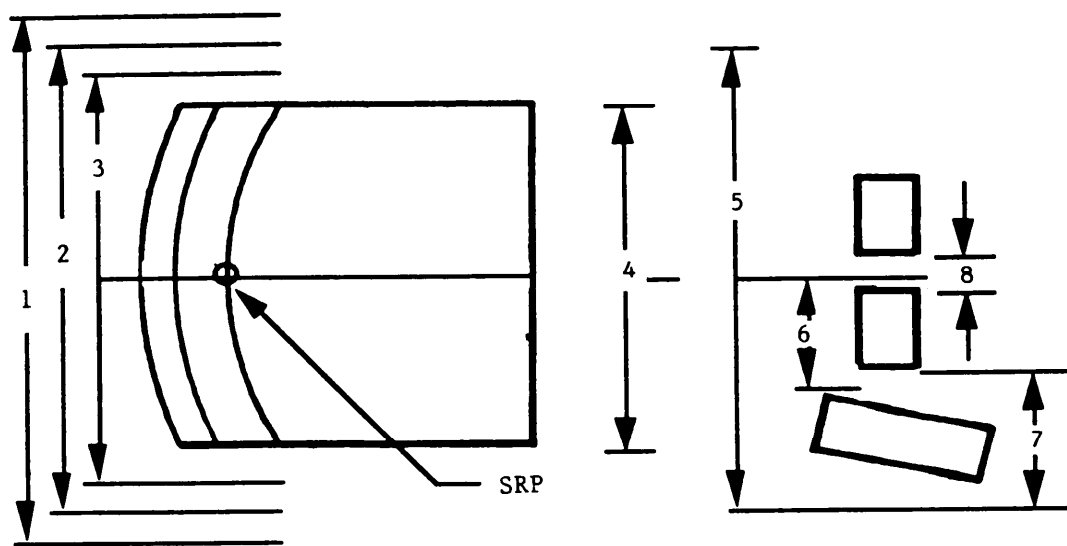

B. SIDE VIEW

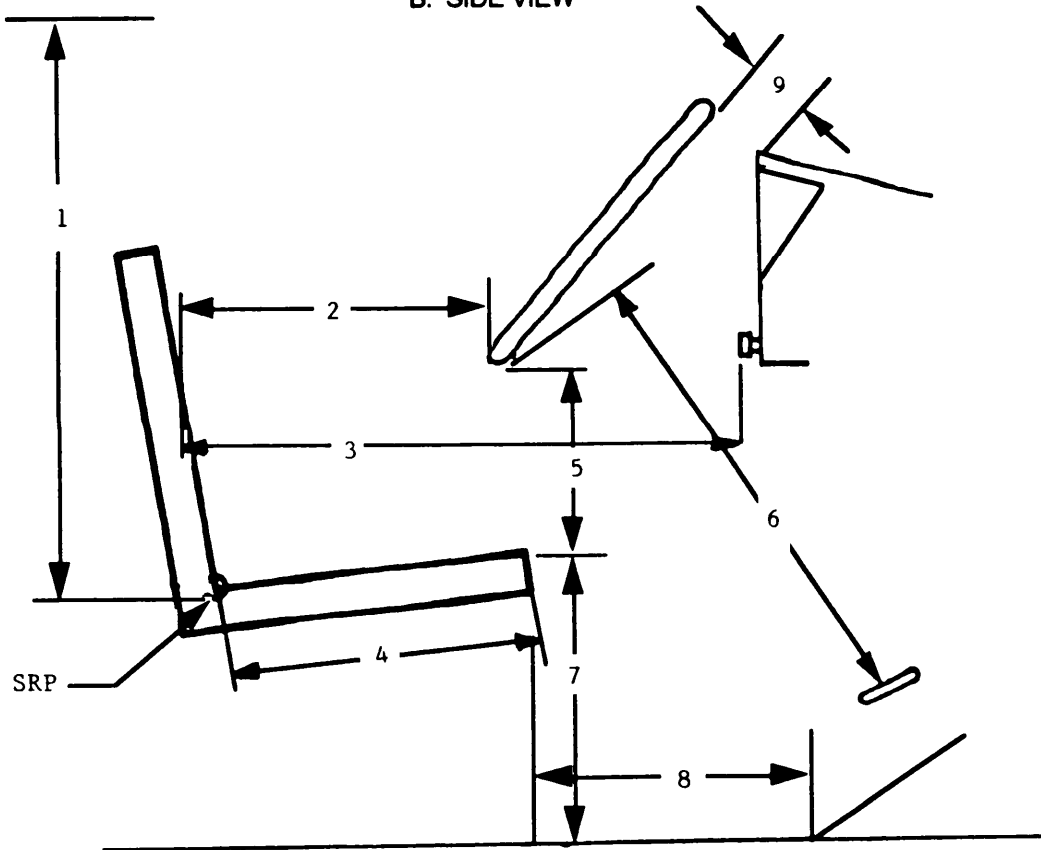

FIGURE 139. Recommend clearances around equipment operator's station

MIL-HDBK-759B

TABLE 72. Recommended station dimensions/clearances to accommodate the 95th percentile equipment operator dressed in arctic clothing

<u>Measurement</u>	<u>Anthropometric Determinant</u>	<u>Dimension</u>
A. 1. Station width (optimum)	Elbow breadth (dynamic)	910 mm
2. Station width (minimum)	Elbow breadth (static)	710 mm
3. Station width at shoulder height	Shoulder breadth	585 mm
4. Station width in knee area (minimum)	*Knee breadth	460 mm
5. Station width in knee area (optimum)	*Knee breadth (relaxed)	610 mm
6. Brake pedal width	Foot breadth	150 mm
7. Accelerator pedal area width	Foot breadth	150 mm
8. Pedal clearance (minimum)		50 mm
B. 1. Station height	Sitting height (erect)	1065 mm
2. SRP to steering wheel	*Abdominal extension depth (sitting)	405 mm
3. SRP to manual/panel controls	Buttock-knee length	735 mm
4. Seat depth (SRP to edge of seat pan)	Buttock-popliteal length	405 mm
5. Steering wheel to seat cushion	Thigh clearance (static)	240 mm
6. Brake/clutch pedal to steering wheel	Thigh clearance (dynamic)	660 mm
7. Seat pan height	Popliteal height	380 mm
8. Footspace: seat pan to heel point acceleration	Foot length	355 mm
9. Clearance around steering wheel	*Hand clearance	75 mm

NOTE: Seat in Lowest and Rearmost Position

*Not standard anthropometric measurement.

MIL-HDBK-759B

- c. tail lights to indicate the rear of the vehicle/equipment,
- d. instrument panel lights to illuminate the instruments (see 5.4.5.8), and
- e. exterior lights, such as spot lights, signal lights, blackout lights, stop and, in some cases, backup lights.

5.8.4.18.2 Headlights. Design of headlights should allow the driver the choice of either upper (bright) or lower (dim) distribution of light, illuminate at least 150 m of roadway in front of the vehicle/equipment under clear atmospheric conditions when the upper headlight beam is in use, and be designed so that the regular (bright or dim) headlights cannot be turned on when the blackout system is on.

5.8.4.18.3 Blackout driving light system.

5.8.4.18.3.1 Master switch. The blackout master switch should be designed so that it cannot be switched into the normal (bright or dim) modes by accident. In order to change the blackout switch to the normal modes, the operator should have to perform some preliminary action (such as pushing a release button) so that activating the bright lights becomes a deliberate act. This is necessary to prevent enemy detection of military vehicles under blackout conditions.

5.8.4.18.3.2 Location of light source. If only one blackout light source is provided it should be mounted on the left-hand side of the vehicle, as far forward and aimed as near the driver's line of sight as practicable.

5.8.4.18.3.3 Beam criteria. On a level road, the blackout beam should be 9 m wide at a point 6 m in front of the vehicle (decreasing in intensity from 6 m to a point 30.5 m in front of the vehicle) with the top of the beam directed at least one degree below the horizontal.

5.8.4.18.3.4 Marker lights. Blackout marker lights should follow MIL-L-3976.

5.8.4.18.4 Reflectors.

5.8.4.18.4.1 General. Side and rear reflectors should be mounted between 0.6 and 1.5 m above the ground. When reflectors are used on vehicles or equipment which have extending pods, arms, or other devices, the reflector should remain visible when they are extended or in the stowed position.

5.8.4.18.4.2 Concealment. Reflectors should be concealed (taped) during blackout conditions to prevent detection by enemy forces.

5.8.4.19 Mirrors. Where two exterior rear-vision mirrors are provided, they should be located so that the driver has rear view capability along both sides of the vehicle. Mirrors should be braced and clamped so that vibration will not blur the view. If the mirror structure is to be used as a handhold for entering the vehicle, or for

MIL-HDBK-759B

maintenance operations, it should be securely braced to prevent misalignment of the rearward view. Use of rear-vision mirrors in combat vehicles should be avoided. However, when such vision to the rear is required and no alternative means are available, mirrors should be guarded from tree limbs and flying debris to the maximum extent possible without negating their function.

5.8.4.20 Windshields.

5.8.4.20.1 Field of view The driver of a vehicle should have at least a 180° field of view of forward vision (90° field of forward vision on each side of the vehicle longitudinal centerline). A 220° field of forward vision is even more desirable. In most cases, vision through side windows will be required to meet these criteria.

5.8.4.20.2 Vision criteria. Trucks should be designed to enable the operator, in the normal operating position, to view the ground at all distances beyond 2.5 m in front of the vehicle. When necessary, mirrors may be used to meet this criteria. Upward visibility should extend to at least 15° above the horizontal.

5.8.4.20.3 Critical visual area. The critical visual area extends to, and often beyond, the vehicle's left corner post. It is better to use a narrow corner post (not over 50 mm wide) than to use a wrap around windshield, which may distort important visual areas.

5.8.4.20.4 Materials. Windshields should not be made from materials that distort vision. They should be flat glass sections wherever possible; if curves are used, the radius of curvature should be as large as possible to reduce distortion. The material should be shatter-proof.

5.8.4.20.5 Obstructions. Door posts, windshield wiper motors, and other devices should not obstruct vision. Interior surfaces should not reflect glare into the driver's eyes or onto the windshield.

5.8.4.20.6 Forklifts. The configuration of forklift mechanisms and forklift truck cabs should permit the operator to have direct view of the tips of the forks in all typical modes of material loading and in all likely operator positions.

5.8.4.21 Windshield wipers.

5.8.4.21.1 General. Windshield wipers should clean the areas of the windshield that the driver must see through in order to operate the vehicle properly.

5.8.4.21.2 Electrical operation. Electrically operated rather than vacuum operated windshield wipers should be used. The electric wiper motors should be at the bottom of the windshield and the wiper blades should return to the bottom when the motor is turned off. An emergency handle should be provided that allows manual operation of the wipers.

MIL-HDBK-759B

5.8.4.22 Windows.

5.8.4.22.1 General. In addition to the windshield area, closed-cab vehicles should have at least one easily opened/closed glass or curtained aperture on each side of the driver's compartment. When possible, there should be a rear window so that the driver can see out over the cargo bed.

5.8.4.22.2 Buses. Every bus that seats eight or more passengers, should have provisions for passengers to escape through the windows. Each push-out or other type of escape window should be clearly identified, by prominent, legible instructions, which include the simple steps to open the escape exit.

5.8.4.22.3 Materials. Transparent materials selected for windows should be shatter-proof and should neither distort nor obscure vision.

5.8.5 Crew stations in combat vehicles.5.8.5.1 Hatches.

5.8.5.1.1 General. The soldier's ability to enter and leave a vehicle fighting compartment easily and quickly is an important tactical consideration. Similarly, it is very important to assure that wounded or incapacitated crew members can be evacuated, and that crew members who work below hatches can do their jobs correctly and comfortably. These are important considerations in hatch design size and configuration.

5.8.5.1.1.1 Size. The size of openings in the vehicle should be limited to maintain the structural and ballistic strength of vehicle fighting compartments. Hatch size is, therefore, of critical importance. The size and shape of the hatch is determined by the soldier's body dimensions (shoulder breadth), clothing, and the tasks to be performed. Considerations also should be given to protrusions or obstructions above, below, and around the hatch which may seriously restrict accessibility to or through an otherwise adequate opening.

5.8.5.1.1.2 Accessibility. All hatches, doors, handgrips, and latches should be large enough to accommodate a suitably-clothed and -equipped user with applicable 5th to 95th percentile body dimensions. In addition there should be a clear path from each hatch to the crew position(s) it serves.

5.8.5.1.1.3 Operation. Adequate handgrips and footsteps should be provided to help the crew reach vehicle hatches easily and safely from the ground. The operator should be able to latch and lock the hatch or door easily, in one continuous motion with one hand, from within the vehicle. The handgrips and latch handles should be adequately insulated for use in both hot and cold climates where surfaces are exposed to temperature extremes. Latch handles should be designed so that they will not freeze and become inoperable under cold conditions.

MIL-HDBK-759B

5.8.5.1.2 Overhead hatches.

5.8.5.1.2.1 Operating forces. Overhead hatches should require no more than 220 N of force for opening or closing under any condition of vehicle tilt and should be operable by a suitably-clothed and -equipped user with 5th percentile arm and hand strength. Release latch handles on emergency exits should require no more than 110 N of force in a lateral direction or 200 N pull. This operation should be possible using either hand and should require no more than two distinct and different motions. Latches that must be operated with both hands should be avoided.

5.8.5.1.2.2 Safety. A positive latch should be provided to hold the hatches open under all operational circumstances. Appropriate padding should be provided around the hatch opening and on the underside of the hatch door to prevent injury to crew members while using or maintaining the latch.

5.8.5.1.3 Circular and rectangular hatches.

5.8.5.1.3.1 General. The hatch sizes recommended in the following paragraphs assume 50 mm or thinner armor. If armor is thicker than 50 mm, or if other design features make hatch opening tunnel-like, the dimensions for prone crawl space should be used (see Figure 80 and Table 56).

5.8.5.1.3.2 Circular. Circular hatches should have a minimum diameter of 560 mm; however, if the circular hatch is to be used for entry or exit of personnel wearing arctic clothing or as an opening through which work is performed (such as the tank commander's hatch), the hatch should have a minimum diameter of 710 mm.

5.8.5.1.3.3 Rectangular. Rectangular hatches should have minimum dimensions of 405 x 610 mm when intended for standard-clothed, one person usage. For arctic clothing, minimum dimensions of 510 x 710 mm should be provided. For simultaneous use by two persons, minimum dimensions of 1.22 x 1.53 m should be provided.

5.8.5.1.4 Contoured hatches. The design depicted in Figure 140 represents the recommended size and configuration for a contoured hatch which is intended for standard-clothed, one person usage. For arctic clothing, minimum dimensions should be 510 x 710 mm.

5.8.5.1.5 Floor-mounted, circular escape hatches. A minimum diameter of 560 mm should be provided for floor-mounted escape hatches. At least 460 mm of clearance should be provided from the bottom of the hatch to the ground.

5.8.5.2 Crawl space.

5.8.5.2.1 General. Fighting vehicles often have a crawl space so that crew members can move from one compartment to another. The size and configuration of these crawl spaces should be adequate so that personnel can move quickly between stations and reach designated escape hatches during an emergency.

MIL-HDBK-759B

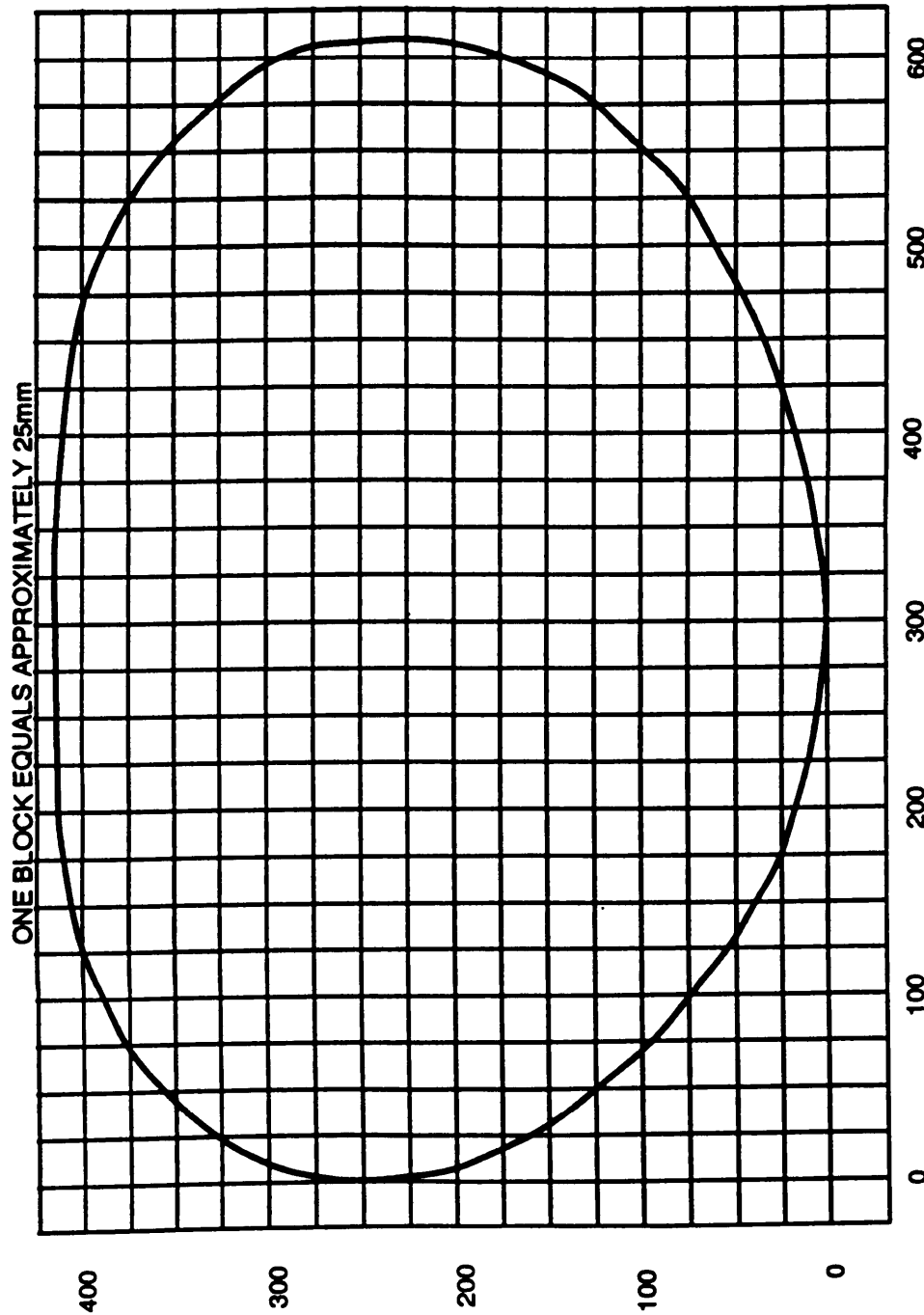

FIGURE 140. Contoured hatch dimensions (mm)

MIL-HDBK-759B

5.8.5.2.2 Dimensions. For knee-crawling passage, the space provided should be 785 mm high by 635 mm wide. For prone-crawling passage, the space provided should be 510 mm high by 710 mm wide.

5.8.5.3 Crew compartment lighting. See 5.4.5 for further information on lighting requirements.

5.8.5.4 Cupolas (levels and vehicle fighting compartment).

5.8.5.4.1 General. A round, overhead cupola ring should be a minimum of 710 mm in diameter. The cupola and all its components (including armament) should be designed to accommodate the suitably-clothed and -equipped operator with applicable 5th through 95th percentile body dimensions. The interface between the crew member wearing the CVC helmet and the cupola sight and vision blocks should be given special attention (see Figure 60). The cupola vision blocks should provide 360° of vision in either buttoned or unbuttoned modes of operation. Cupolas should have an easy to use, positive lock so that they may be secured in any position.

5.8.5.4.1.1 Forces. When cupolas are operated in the manual mode, they should not require more than 2.5 N•m breakaway force or 1.7 N•m sustained force at the cupola rim.

5.8.5.4.1.2 Controls. The azimuth and elevator controls should be located within the operator's functional reach when operating in either the open or closed hatch modes. These controls should not strike or otherwise interfere with the full range of expected operators.

5.8.5.4.2 Armament. Cupola armament should be designed so that it can be charged, loaded, unloaded, adjusted, and serviced in either the open or closed hatch mode. An individual crew member should be able to install and remove a 50-caliber or smaller weapon without assistance. The charging resistance of the cupolas armament should not require more than 340 N•m breakaway force or 80 N•m of sustained force. The charging handle should not travel more than 305 mm. Ammunition ready boxes should be readily accessible and easy to use. When spare barrels are to be carried in the compartment, there should be an appropriate provision (kevlar gloves) for changing hot barrels. An index mark should be provided on the rim to show the azimuth at which the main armament is aimed.

5.8.5.5 Travel locks.

5.8.5.5.1 General. A method to unlock external travel locks should be provided from within the protection of the vehicle.

5.8.5.5.2 Exposure to heat. The parts of the travel locking mechanism that users should handle should have low heat conductivity so that they will not become too hot to touch in warm climates. This mechanism should not be located close to the engine, exhaust, or other heat sources since this may also cause unacceptable heating.

MIL-HDBK-759B

5.8.5.5.3 Exposure to cold. Personnel wearing arctic mittens should be able to remove the retaining pin (if applicable) and operate external travel locks. Travel locking mechanisms should be designed so that they will not freeze and become inoperable under cold weather conditions.

5.8.5.6 Crew compartment safety.

5.8.5.6.1 Protective padding. Provisions for crew safety should include appropriate padding in areas where crew-equipment contact may occur. Protective padding should not be placed routinely in standard, traditional parts of the vehicle fighting compartment. Each vehicle design and development program should evaluate the individual padding requirements for its vehicle and then place protective padding only in those areas where the crew-equipment interface warrants padding. As a rule, padding will be required to protect against both vehicle induced motion (over rough terrain) and crew members accidentally bumping against objects while moving within the vehicle. Designers should consider that the application of protective padding reduces usable compartment space which may limit the 95th percentile user (particularly in arctic clothing) and degrade task performance. In selecting padding, designers should always consider materials with superior energy-dissipating properties. Padding materials should not be abrasive to the skin, contain toxic agents, or feel sticky. Currently available padding does not, by itself, dissipate energy well enough to protect the head adequately. Personnel should wear protective head gear at all times when working in vehicle fighting compartments.

5.8.5.6.2 Guards/shields. If it is not possible to adequately separate personnel from moving equipment, appropriate guards or shields should be provided so that fingers (or other body parts), clothing, and equipment are protected during vehicle operation.

5.8.5.6.3 Sharp corners, protrusions and other obstacles. All sharp corners and protrusions, which may catch clothing or impede crew performance, either during entrance and exit or during vehicle operations, should be eliminated or, if this is not possible, means should be taken to minimize the problem (padding). There should be no loose wires or other items to entangle or restrict personnel entering or leaving the vehicle or while operating with an open or closed hatch.

5.8.5.6.4 Other safety considerations. Hot expended cartridge cases/ links, should neither come in contact with personnel nor be cast upon surfaces on which they are standing, causing them to lose their footing. The noise level within crew compartments should not exceed the limits described in the current issue of MIL-STD-1474. Anti-skid surfaces should be provided where the crew and maintenance personnel must step to perform their tasks. Protection should be provided against all noxious toxic substances in crew/maintenance areas.

5.8.5.7 Brow pads. The functions of a brow pad are to stabilize the observer's eye within the exit pupil of the sight or viewing device and to absorb energy which would otherwise be absorbed by the human head, resulting in damage to internal organs, bone structure, or external tissue. In addition to increasing the impulse reaction time by its inherent energy absorption qualities, the brow pad distributes the

MIL-HDBK-759B

impulse load over a wide area which prevents a potentially damaging force from being exerted at one point or location. Brow pads should be compatible with eyeglasses, protective masks, and the CVC helmet (see Figure 60).

5.8.5.8 Vision blocks and periscopes.

5.8.5.8.1 Mounting. Periscopes which are mounted around the perimeter of a hatch opening should be easily retractable to a stowed (lowered) position to improve open hatch vision over the hatch perimeter. Periscope mountings should be designed to absorb the vibration which may degrade visual acuity.

5.8.5.8.2 Field of view. Vision blocks and periscopes should be designed and located so that there is an overlap between their fields of view. This overlap reduces the time required for reorientation when changing from one vision block to another.

5.8.5.8.3 Blackout shield. A suitable blackout shield which may be engaged from within the vehicle should be provided on vision blocks. These shields protect against enemy detection through vehicle light leakage and also protect the crew's eyes from adverse visual effects associated with explosion flashes.

5.8.5.9 Command's station.

5.8.5.9.1 General considerations for the designer.

5.8.5.9.1.1 Open hatch operation. Since surveillance is such an important part of the commander's function, the field of view should be kept as clear as possible. The commander's view of the terrain surrounding the vehicle may be restricted by blind spots caused by the configuration of the vehicle and its appendages. For example, the horizontal-forward-facing main weapon on a tank will hide an object located to the lower-left-front of the vehicle when the weapon comes between the commander's eye and the object.

5.8.5.9.1.2 Closed hatch operation.

5.8.5.9.1.2.1 General. When the commander operates from the closed hatch position, vision is usually restricted by the protective armor around him. The commander views the terrain surrounding the vehicle from vision blocks (see 5.8.5.8) or he may view more distant objects (targets) magnified by the main weapon or commander's weapon sights.

5.8.5.9.1.2.2 Visual problems. When transferring from one vision block to another, the commander should reorient himself to the surrounding terrain because visual cues are relocated. A minimum of 50 mm of helmet clearance should be provided.

MIL-HDBK-759B

5.8.5.9.2 Seat adjustment.

5.8.5.9.2.1 General. The commander should be provided with a seat which is comfortable and can accommodate the full range of suitably-clothed Army personnel (5th through 95th percentile). The seat should adjust continuously, or in maximum increments of 25 mm, to provide good open hatch surveillance and comfortable access to all sights and viewing devices.

5.8.5.9.2.2 Adjustment mechanism. The seat adjustment mechanism should be easily operable by the seated commander. The location and position of the commander's seat, in either the open or the closed hatch modes, should not require awkward body positions.

5.8.5.9.2.3 Adjustable seat back. The seat back also should be adjustable to accommodate the size range of commanders.

5.8.5.9.2.4 Adjustments (fore and aft). Fore and aft adjustment of the seat, in 25 mm increments or less, should be provided to allow the commander to operate all necessary controls and vision devices while seated.

5.8.5.9.2.5 Platform. The commander's seat should be capable of being folded out of the way to allow operation in a standing position. A platform, big enough to accommodate a 95th percentile male wearing arctic boots, should be provided. Platform adjustment should allow the full range of commanders to operate effectively during all modes of operations. This platform should have an adjustable range of not less than 255 mm and have a relatively even-with-the-floor down position, or retract to stow against the wall.

5.8.5.10 Gunner's station.

5.8.5.10.1 General considerations for the designer. The gunner is often less mobile than the other turret crew members and presents special problems for the designer. They may be confined to their seats for long periods of time and will require special visual orientation, ventilation, and seating comfort considerations.

5.8.5.10.1.1 Visual orientation. Gunners in a rotating turret can develop disorientation, anxiety, and nausea if they are unable to look out at the terrain and receive visual cues about their relationship to the world. The gunner's primary sight is not very helpful in gathering these cues because it usually presents a small field of view and magnified image or is not available at all because the gun is elevated. The gunner should be supplied with a periscope or one or more wide angle unity vision blocks to allow them to look out of the vehicle. Even if the view provided by these vision blocks rotates with the turret, it will supply him with the cues he needs.

5.8.5.10.1.2 Ventilation.

5.8.5.10.1.2.1 General. Each crew position within the vehicle compartment should be ventilated properly. Crew ventilation should be separate from engine ventilation and should function properly when the vehicle is stationary or in motion.

MIL-HDBK-759B

5.8.5.10.1.2.2 Special ventilation needs. If the design of the compartment confines the gunner to his station so that he cannot move about within the vehicle or ride open hatch between engagements, special sources of ventilation should be provided. This special ventilator should have controls accessible to the gunner for direction of flow, velocity, and air temperature.

5.8.5.10.1.3 Gunner's seat.

5.8.5.10.1.3.1 General. The gunner should be provided with a seat which will accommodate the full range of suitably-clothed Army personnel (5th through 95th percentile). The seat should have fore/aft and vertical adjustment in increments of 25 mm or less to provide the gunner with the optimum interface with his controls and optical equipment. The gunner should be able to operate the seat adjustment mechanism while seated.

5.8.5.10.1.3.2 Other considerations. The seat should be rectangular in shape, 380 to 480 mm deep and not less than 380 mm wide. It should have an adjustable backrest of sufficient curvature to provide good lateral support, particularly if the vehicle has fire-on-the-move capability. Footrests and adequate leg room should be provided for the occupant of the seat. A restraint system also should be considered in maintaining position behind the sight, particularly if a monocular sight is used. There should be adequate clearance for the full range of suitably-clothed Army personnel to enter or leave the seat. Adequate knee clearance for suitably-clothed 5th through 95th percentile gunners should be provided with the gunner's seat in its full aft position.

5.8.5.11 Loader's station.

5.8.5.11.1 General considerations for the designer. The loader's station should accommodate the 5th through 95th percentile Army loaders, appropriately dressed, when riding open hatch in the standing position, riding closed hatch in the seated position, or while holding a round (standing or seated), without entering the armament's path of recoil.

5.8.5.11.2 Seat. The loader's seat should be designed for vertical adjustment, easy conversion to an open hatch standing platform and easy removal for stowage elsewhere in the vehicle.

5.8.5.11.3 Recoil. A safety feature should prevent the gunner or the commander from firing the main weapon while the loader is in the path of recoil.

5.8.5.11.4 Case ejection. If spent brass ejection is violent enough to be a hazard to personnel or equipment, appropriate energy absorbers should be provided.

5.8.5.11.5 Vision. The loader should have an optical device to see outside of the vehicle during closed hatch operations.

MIL-HDBK-759B

5.8.5.11.6 Maintenance of secondary armament. There should be adequate space for the appropriately-clothed and -equipped 5th through 95th percentile loader to service the secondary armament. One crew member, in the fighting compartment, should be able to change the barrel of the secondary weapon.

5.8.5.11.7 Ventilation. Main weapon loading procedures usually require relatively high physical effort from the loader. Task degradation may result if the compartment is not properly ventilated to provide fresh air to dissipate excess heat.

5.8.5.12 Driver's station.

5.8.5.12.1 General considerations for the designer. The driver should be provided with seating, controls, and optics which may be used effectively in all required modes of operation by the full range of suitably-clothed and -equipped Army drivers. For example, if both open and closed hatch modes are required, the driver should be able to perform all of his tasks, under all types of possible conditions (day/night, wet/dry, hot/cold) in either mode.

5.8.5.12.2 Driver's workspace. Sufficient clearance should be provided for the arctic clothed 95th percentile driver to easily enter or leave the station by every hatch and passageway provided, without undue interference from obstruction. The mechanisms to change or adjust seating configurations, lock or unlock hatches or operate other station equipment, should be accessible, easy to use, operable by personnel with 5th percentile strength, and not require that the driver assume awkward positions during operation.

5.8.5.12.2.1 Seat. The driver's seat should accommodate 5th through 95th percentile operators in the full range of clothing in either closed or open hatch operation (approximately 380 mm to 435 mm deep and 380 mm to 510 mm wide). Adjustment of the seat should allow the driver to operate all necessary controls and optical devices during open or closed hatch modes. Particular attention should be given to open hatch head clearance when the driver's hatch is under or near a rotating turret or weapon.

5.8.5.12.3 Emergency evacuation. It should be possible to remove an incapacitated driver either through the hatch or internally into the turret area. Removal into the turret should be possible without any of the crew exiting the vehicle to assist.

5.8.6 Tank gun control systems.

5.8.6.1 General. Controls should be designed and located so that the full range of Army personnel can operate them without having to assume awkward positions. Crew members with task descriptions that require the assumption of several working postures (seated, standing) should have controls which can be easily used in each required posture. Any adjustments that must be made to the operator's seat, standing platform, or other devices, in order to achieve an alternate workspace posture, should be readily accessible and operable from whatever posture the operator may be in at the time.

MIL-HDBK-759B

5.8.6.1.1 Placement and use. The placement of elevation and azimuth weapon controls should be compatible with the location of sights, rangefinders, and other essential fire control equipment. The gunner should have both power and manual control of the gun system in elevation and azimuth and should be able to operate them in either mode, without substantial loss of efficiency, while wearing appropriate hand wear. Manual hand cranks should be immobilized during power operation of the weapon control system without engaging a lock or detent in a preselected position of rotation.

5.8.6.1.2 Control compatibility and transfer. The degree of weapon system control provided for the commander should be the same as that provided for the gunner. The change over of weapon control from the gunner to the commander should be smooth and efficient.

5.8.6.1.3 Type of controller. Dual hand controllers are generally superior to single hand controllers for rapid and precise line of sight corrections of elevation and azimuth in gun stabilized modes of operation. These controllers increase body stabilization for the gunner when properly placed to aid in his balance. If optical rangefinders are to be operated by the gunner, it may be more advantageous to utilize a one-hand weapon controller. This type of control should be used in conjunction with separate body supports.

5.8.6.2 Manual controls.

5.8.6.2.1 Manual control response ratio. The optimum range of manual control response is 10 to 20 roils of azimuth per revolution and 10 to 15 roils of elevation per revolution. From the standpoint of training, uniform rates of response are desirable in all fighting compartments. To obtain moderate hand-crank operating forces, the response ratio should approach minimum values but should not be less than the lower limit specified (see Figure 1).

5.8.6.2.2 Manual hand-crank force. Manual azimuth traverse should be designed to permit controlled manipulation of the turret through 360°, with the vehicle canted or pitched 15°. Hand-crank force for manual azimuth should not exceed 40 N. An elevation cranking force of 22 to 40 N is considered suitable for both starting and continuing motion. When comparing system results with specified force or torque values, ease of operation, operator fatigue, configuration of the hand crank, and location of the hand crank in relation to the operator should be considered.

5.8.6.2.3 Physiological factors. When a tank is tilted, it will become increasingly difficult to manually crank the turret toward the high end of its rotation. Generally, at 10° or greater tilt, the gunner will have to remove his eye from the periscope and assume a braced position using one or both hands or changing from one hand to the other in order to complete 360° traverse. A turret can be traversed for about 15 minutes at slow speeds, 5 minutes at moderate speeds and less than 3 minutes at fast speeds, when manual effort remains steady and below 6.8 N•m. At fast manual traverse, under level conditions, the gunner will have difficulty keeping his eye to the periscope. Tremor will set in after traversing about 180°, and it will generally be impossible to continue at fast manual traverse beyond 1.5 revolutions.

MIL-HDBK-759B

5.8.6.2.4 Manual control backlash. Backlash can influence speed and precision during the engagement of stationary point targets. It may also affect the retention of gun alignment on target during manual firing procedures. Gun and turret control systems should be designed to minimize backlash with the maximum backlash movement not exceeding 1.0 roils in traverse and 1.4 roils in elevation.

5.8.6.3 Power controls.

5.8.6.3.1 Power controller characteristics. The hand controller should be designed to provide a positive response to small deflections to permit rapid, precise, point-target engagement. The controller's dead spot should not exceed $\pm 2^\circ$ and should be equal in each direction from the center position. Positive centering of the released controller and zero controller backlash should be provided.

5.8.6.3.2 Controller operating torque. Ease of handling and manipulation are important factors in operation of gun control systems. Power controller operating torque should not exceed 6.8 N•m.

5.8.6.3.3 Response rates. The graphic presentation of data shown in Figure 141 indicates desirable characteristics and an optimum traverse response curve. Considerations in design should include irregularities of response, difficulties of controlling the turret and gun in motion, and limitations of performance caused by response slope characteristics and extreme response values.

5.8.6.3.4 Acceleration. A typical engagement of a combat target requires traversing the fighting compartment through 1600 roils or less; the ability to engage a target in the minimum time depends on the angular acceleration/ deceleration provided by the power gun-control system. An appropriate method to provide this acceleration/deceleration should be incorporated into the system design.

5.8.6.3.5 Controller override and shift time. The commander's controls should be designed to override the gunner's control of the system. The time required to shift control from the gunner to the commander or vice versa should be minimal. The time required to shift the gunner's control from power to manual or vice versa should be minimized and the shift should be accomplished with as few operations as possible.

5.8.6.3.6 Utility and compatibility of operation. "Built-in" leveling, boresighting, and synchronizing features should be provided on fire control equipment whenever practical.

5.8.6.3.6.1 Slippage. Main gun slippage, with the travel lock disengaged, should be negligible during all normal maneuvering. The gun elevating system torque overload relief device should permit main gun slippage at a torque just below that which would cause damage to the system.

MIL-HDBK-759B

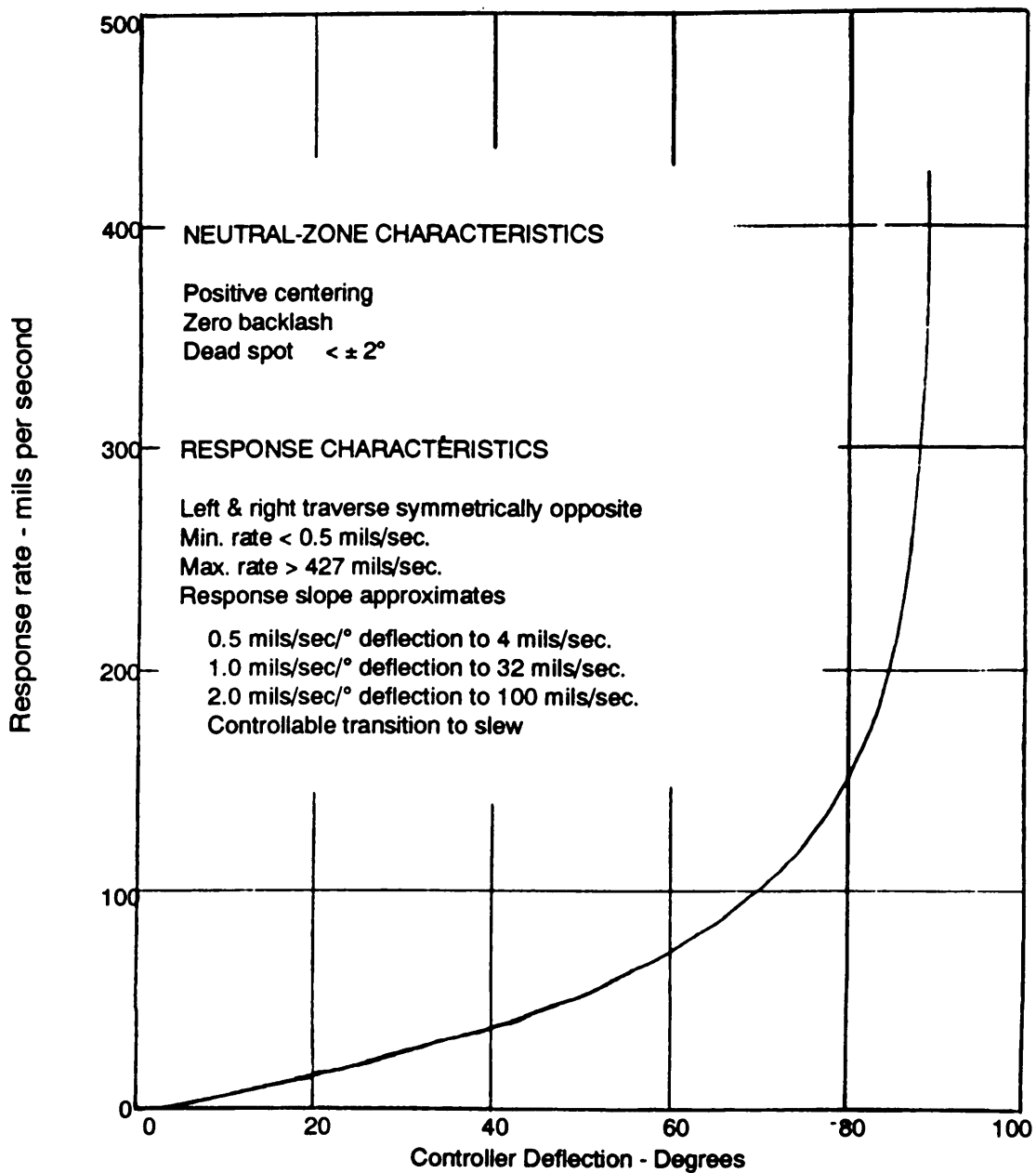

FIGURE 141. Optimum power-traverse response rates

MIL-HDBK-759B

5.8.6.4 Fire control maintenance.

5.8.6.4.1 Mechanical equipment. To keep maintenance of mechanical equipment to a minimum, the designer should review the considerations discussed below.

- a. The number of different types and sizes of bolts, nuts, and screws used as fasteners should be kept to a minimum.
- b. When feasible, locking levers should be used instead of nuts or screws.
- c. Where practicable, lock washers should be captive to their bolts or screws.
- d. Set screws should be utilized where keyways or splines are provided.
- e. The method of pinning gears should be standardized throughout the system.
- f. Split pins should not be used in place of conventional taper pins.
- g. Split clamp couplings should be used instead of sleeves to facilitate replacement of parts and adjustments.

5.8.6.4.2 Hydraulic equipment. To keep maintenance to a minimum, the designer should review the considerations discussed below.

- a. Lines containing high-temperature or -pressure fluids should be routed away from crew compartments or should have provisions, such as safety relief valves or shielding, to protect personnel in case of rupture or contact.
- b. Automatic bleeding should be designed into the system whenever possible.
- c. Adapters, couplings, and hose assemblies that do not require special tools should be used wherever practicable.
- d. Hydraulic systems should be coded (see Table 68).
- e. Permanent metal labels should be provided to identify hydraulic equipment.
- f. Easily accessible, removable filters or strainers should be provided.
- g. Gauges should have external pointer adjustment for ease of adjustment and calibration.
- h. Gauges, meters, and control valves should be placed in a centralized position, readily accessible to the operator.
- i. In case of electrical failure, a means for manual operation of the system should be provided.

MIL-HDBK-759B

5.8.6.4.3 Accessibility of components. To ensure proper accessibility of components, the designer should review the considerations listed below.

- a. Doors or hinged covers should have rounded corners, slip hinges, and stops to hold them open.
- b. Fast action, captive fastening devices which do not require special tools, should be used for covers and access plates.
- c. Access should be provided (on both sides of equipment if feasible) with sufficient hand room for adjustment of instruments, removal or replacement of equipment, and servicing of lubrication fittings.
- d. Lubrication fittings should be clearly marked to avoid servicing errors.
- e. Rotating of pull-out assemblies should be provided where feasible to facilitate access of several components through a single opening.
- f. If equipment is mounted with bolts or screws, they should be accessible to allow installation and removal of equipment without removing other parts or equipment.
- g. If other types of fastening devices are used, they should be designed and located to facilitate removal of equipment without special tools.
- h. High-mortality items should be located near access openings to permit quick replacement or repair.
- i. Where the operator must make adjustments, adjusting devices should be external to the operating mechanism to expedite servicing.

5.8.7 Optical instruments and associated equipment.

5.8.7.1 General. This section pertains to image forming optical systems. The information is quantitatively presented in order that human capabilities and limitations can be adequately taken into consideration in the design, engineering, operations, and maintenance of optical military equipment. Detailed instrument parameters, and characteristics will be regulated by governing military specifications and user applications and requirements. Necessary characteristics of military optical instruments in addition to user comfort, safety, and clarity of vision usually include a minimum of weight and bulk, the largest possible field of view and brightness of image consistent with the necessary magnifying power, freedom from optical distortions, and a combination of ruggedness with simplicity.

5.8.7.2 Visual parameters. The following should be considered as observer vision parameters or tolerances.

MIL-HDBK-759B

- a. Visual spectrum: 400 nm ($400 \times 10^{-9}\text{m}$) through 700 nm.
- b. Visual acuity: 60 sees of arc for the emmetropic eye.
- c. Maximum tolerable astigmatism: 1/4 diopter.
- d. Vernier acuity: 10 sees of arc.
- e. Stereoscopic acuity: 12 sees of arc.
- f. Extra ocular limits for possible onset of ocular fatigue.
 - (1) Abduction: 15 minutes.
 - (2) Adduction: 30 minutes.
 - (3) Supraduction: '15 minutes.
- g. Stimulation - intensity range
 - (1) Smallest detectable (threshold) using rod vision: $3 \times 10^{-6}\text{cd/m}^2$; cone vision: 3.2cd/m^2 .
 - (2) Largest tolerable cone vision: $3 \times 10^4\text{cd/m}^2$.

5.8.7.3 Optical parameters.

5.8.7.3.1 Magnification. Instrument magnification should be sufficiently high to permit efficient performance of the required application such as detection, recognition, identification, and laying.

- a. Within the constraints of good optical design practice, physical and configuration limitations, and environmental and terrain limitations, magnifications should be between 1 power and 20 power.
- b. Because of hand tremors and body motion, magnification of unstabilized, unsupported hand-held sights should not exceed:
 - Rifle and pistol telescopic sights--4 power.
 - Monocular or binoculars--8 power.
- c. If more than one magnification is required, two discrete magnifications should be provided for optimum image quality and boresight integrity. Varifocal (zoom) systems should only be considered for use in systems where sighting accuracy is relatively unimportant and it results in overall simplification.

MIL-HDBK-759B

5.8.7.3.2 **Field of view.** The field of view is the area visible through the instrument. Field of view should be compatible with intended use and optical-mechanical design limitations.

5.8.7.3.2.1 **Apparent field of view.** The apparent field of view is the true field of view multiplied by the magnification. A practical maximum for a highly corrected eyepiece is 60°.

5.8.7.3.3 **Entrance pupil.** The entrance pupil should be equal to the product of the magnification and the exit pupil diameter and therefore is defined by these parameters.

5.8.7.3.4 **Exit pupil.** The diameter of the exit pupil should be consistent with intended use and size/weight limitations. In order to accommodate average pupillary diameters:

- a. for daylight application, the exit pupil diameter should be no less than 3 mm, and
- b. for maximizing performance at twilight and lower light levels, the exit pupil should not be less than 7 mm.

5.8.7.3.5 **Eye relief.** Eye relief is the distance from the eye lens to the exit pupil. A long eye relief (25 mm) is ordinarily desirable on vehicular mounted sights in order to provide the observer with protection from gun recoil, observing on the move, and to afford some field of view while wearing a protective mask. The required eye relief depends upon the particular application but should be at least 15 mm to permit use by observers wearing glasses.

5.8.7.3.6 **Eyepiece Adjustments.**

5.8.7.3.6.1 **4-power and less.** Fixed-focus eyepieces set between -0.5 and -1.00 diopter may be utilized for instruments 4-power and less.

5.8.7.3.6.2 **Over 4-power.** Eyepiece dioptric (focusing) adjustments (-6 to +2 diopters, desired) should be provided and marked on all instruments over 4-power magnification.

5.8.7.3.7 **Optical quality.**

5.8.7.3.7.1 **Axial resolution.** Axial resolution should be equal or better than 300 μrad of arc divided by the magnification in order to provide an eye limited instrument.

5.8.7.3.7.2 **Aberrations.** Aberrations should be controlled in accordance with standard optical design practices and consistent with a cost effective instrument.

5.8.7.3.7.3 **Luminous transmission.** Luminous transmission should be as high as possible, preferably greater than 50%. Optical elements should be anti-reflection coated with the exception of focal plane components.

MIL-HDBK-759B

5.8.7.3.7.4 Boresighting and zeroing. Method of boresighting and zeroing the sights should provide adjustments which are fine enough to enable the operator to position the sights so as to meet weapon system criteria.

- a. Boresight knobs should be provided with a positive lock. The boresight setting should not change when locking.
- b. Boresight knob locks should not require more than 4.5 N force to lock and unlock the knob lock.
- c. Boresight adjustment knobs and locking should be capable of being adjusted, locked-or unlocked by suitably-clothed and -equipped users with hand dimensions varying between the 5th and 95th percentiles.

5.8.7.3.8 Reticles.

5.8.7.3.8.1 General. The reticle should be in focus at a range of primary interest to limit the parallax to an acceptable value throughout the usable range.

5.8.7.3.8.2 Illuminated sights and reticles. A diffuser should be used to provide even illumination.

5.8.7.3.9 Binoculars/bioculars. Where continuous observation and stereopsis (depth perception) is required, binoculars should be provided. Bioculars may be used where depth perception is not required.

5.8.7.3.9.1 Interpupillary adjustment. Binocular/biocular instruments should have an interpupillary adjustment scaled from 50 to 73 mm in one millimeter intervals.

5.8.7.3.9.2 Magnification differences. Magnification differences of the two barrels should not exceed 2%.

5.8.7.3.9.3 Luminous transmission. Luminous transmission differences of the two barrels should not exceed 5%.

5.8.7.3.9.4 Collimation. In order to avoid eyestrain and minimize fatigue, alignment of the binoculars at the eye should not exceed a divergence of the rays at 15.0 minutes of arc, a divergence of the rays at 40.0 minutes of arc, and a convergence of the rays at 25.0 minutes of arc.

5.8.7.3.9.5 Weight. Weight of hand-held binoculars/bioculars should not exceed 1 kg. Instruments should be sized and configured for compatibility with anthropometric requirements.

5.8.7.4 Environmental conditions. Instruments exposed to adverse conditions should be provided with appropriate auxiliary equipment, including cases, windshield wipers, defoggers, and defrosters.

MIL-HDBK-759B

5.8.7.5 Accessories.

5.8.7.5.1 Filters. Light filters, removable from the optical path, should be provided to reduce glare or light intensity, or to protect the observer's eyes against hazardous light levels. A complete analysis should be made of the reduction in illumination and possible decrease in target to background contrast before filters are used.

5.8.7.5.1.1 Use. Use of color or neutral density filters will depend upon the application. For use in observing bright light sources, neutral filters should be considered for reducing overall brightness without affecting contrast. The use of polarizing filters should be considered where it is necessary to reduce glare and increase apparent contrast from sun, snow, or water.

5.8.7.5.1.2 Hazardous light levels. For hazardous light levels from items such as lasers or search lights filter density should be sufficient to reduce energy levels below that specified by the Surgeon General.

5.8.7.5.2 Shutters. Shutters having closure and reopening times appropriate for each application may be provided in lieu of fixed filters to protect the observer exposed to flashes from weapon systems, lasers, and other sources. Shutters for protection of the observer from his own weapon system flash, which may be actuated just before the weapon is fired, should neither disturb the lay of the weapon before closing nor unnecessarily impede the observation of the projectile flight path or resultant impact.

5.8.7.5.2.1 Laser protection. Shutters or laser filters for protection of the observer's eye from laser illumination should reduce energy levels below that specified by the Surgeon General.

5.8.7.5.2.2 Nuclear flash protection. Shutters for protection of the observer's eye from flashes in the field of view resulting from a nuclear device should reduce energy levels below that specified by the Surgeon General. Complete closure within 50 microseconds from flash detection to an optical density of 5 is deemed sufficient to meet minimum protection criteria.

5.8.7.5.3 Cases. Carrying/transport cases should be provided for instruments to be hand-carried or mounted/dismounted frequently.

5.8.7.5.4 Eyecups and headrests. Any optical instrument that requires steady orientation of the eye should be provided with a headrest and/or eyecups.

5.8.7.5.4.1 Eyecups. Eyecups should be provided to maintain proper eye relief, eliminate stray light, and when required, protect or cushion the eyes and orbital region against impact with the eyepieces. Design should also be compatible with protective masks (NBC gear). The radii of Figure 142 define a surface of revolution within which a satisfactory symmetrical eyepiece and cup should be designed if interferences with facial features are to be avoided. These should be supplied to cushion forms when they are compressed to the maximum.

MIL-HDBK-759B

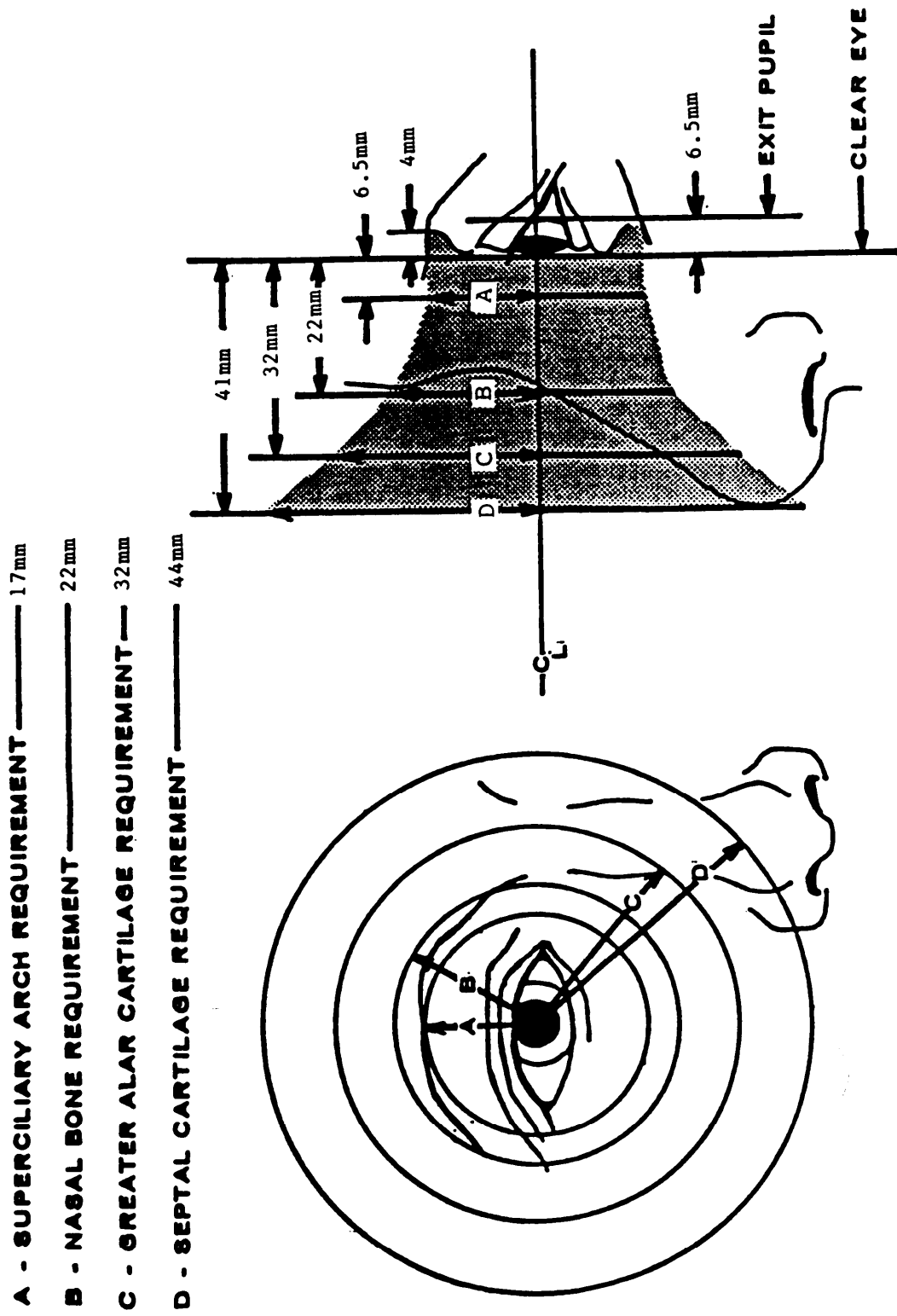

FIGURE 142. Anatomical limits on auxiliary symmetrical ocular metal parts

MIL-HDBK-759B

5.8.7.5.4.2 Compatibility with clothing and personal equipment. Eyecups and headrests should be compatible with helmets, protective masks, and other clothing and personal equipment.

5.8.7.5.5 Mechanical effect of gun recoil on the gunner. The mechanical shock to the tank gunner is primarily transmitted by a pulse in the +X axis (in the direction of the recoil) as the result of contact of his forehead with the brow pad/headrest, and secondarily, by a pulse in the +Z axis (vertically upward) applied by the seat. Loading components are applied in the other two directions both at the head [Y (side to side) and Z axes] and at the seat (X and Y axes), but these are considered to be of lesser importance. The two major loading components applied at the +X axis of the head and the +Z of the seat are felt by the gunner at an interval of about 10 microseconds (μs) apart, with the direct load from the brow pad occurring first. This pulse also induces an angular acceleration of the head in the sagittal plane which may result in physiological and performance decrement. All of these acceleration pulses at the head should be considered in the design of the recoil mechanism to ensure that the desired gunner efficiency (speed and accuracy) is maintained. Deterioration in gunner performance may be defined as his inability, even for brief intervals, to track and engage targets accurately. Weapon recoil may degrade the performance of the other crew members, such as the tank commander, who may also be addressing his sight at trigger pull. Degradation of secondary tasks, such as communications, could affect the target acquisition time and influence overall system performance.

5.8.7.5.5.1 Brow pad function. One of the primary purposes of the brow pad, headrest, or other cushioning device, such as that mounted on the tank gunner's optics, is to modify the pulse at the gunner's head (acceleration transmitted at the weapon recoil) to levels that will not produce performance deterioration and to minimize the potential for injury. The tank gunner's brow pad also provides the proper eye relief as well as a measure of head stability for the use of the optics during on-the-move operations. An initial pressure exerted by the gunner against a brow pad prevents worsening of the exposures from an abrupt direct impact and reduces involuntary motions of the gunner's head/neck system which compromise his ability to perform the required tasks.

5.8.7.5.5.2 Load characterization. The character of the transient load is defined by means of acceleration histories that have been measured at the head of a human gunner and at the center of gravity of the head of an Alderson CG 98 dummy whose physical and mechanical features resemble that of the human test subject. Under these conditions, it appears that an instrumented dummy may be used initially to estimate the overall acceleration pulse transmitted to the human head. Acceptability of the dummy response then allows for the evaluation of acceptability for experienced gunners. Subsequently, the suitability of the system for training novice gunners should be demonstrated. The parameters that may be critical in the histories of both linear and angular acceleration profiles are numerous. These parameters include the peak amplitude, its rise time, the pulse duration and shape, and the dominant frequency of its components, as well as the total pulse applied and the average acceleration level experienced. By analogy with more intensive loads causing trauma (long-term and permanent damage, including fatality), the most important parameter in the evaluation of performance deterioration may be peak or average acceleration, although other factors cited also are of importance. Experience has indicated that the

MIL-HDBK-759B

preponderance of gunners can sustain a peak level of 4g (+X direction) associated with the firing of a 152mm gun from the M60A2 tank and remain in constant combat-ready condition. The acceleration histories recorded at the head and base of the neck of a human gunner firing this tank system are shown in Figure 143. A similar set of acceleration histories, shown in Figure 144, which were derived from the response of the same human gunner firing the 152mm cannon from an M551 vehicle, resulted in a peak acceleration of 12g at the head (+X direction). Subjective responses of the gunners to this latter acceleration suggesting hesitation in trigger pull, combined with film records which demonstrate an anticipatory "flinch" occurring just prior to the trigger pull action indicate potential degradation in gunner performance. In consequence, the tank gun system, seat, and brow-pad design should be integrated so as to approximate the acceleration parameters exhibited in Figure 143 as closely as possible. Since the effect of departures from this profile on performance is, at this time, uncertain and significant changes in peak amplitude, rise time, pulse duration and shape may adversely affect performance, it is recommended that every effort be made to stay within the confines of Figure 143 and to evaluate the cost changes as these design restraints are relaxed. Under no circumstances should the peak +X acceleration be allowed to exceed +8g unless acceptable gunner performance and exposure level acceptance have been demonstrated.

5.8.7.5.3 Design considerations. Achievement of minimum acceleration levels and the total impulse to the gunner's head as well as appropriate rise time and duration are crucial for effective gunner performance and every effort should be made to accomplish this objective by overall tank design. Suspension system design has minimal influence on the acceleration input to the gunner's head at recoil. Data indicate that the response of the vehicle suspension occurs after cessation of the recoil input to the gunner's head. There is also no evidence to suggest that variations in brow-pad material will significantly reduce accelerations to the gunner's head. Although development of efficient damping and mounting systems for the brow pad and seat may offer potential modification of the acceleration input to the gunner, the key to achieving a significant reduction in this input appears to lie in the design of the recoil mechanism.

5.8.7.6 Mounts and supports. Mounts and supports should provide for positive positioning and positional adjustment of the instruments. These devices should be designed so as to facilitate insertion and removal of instruments. All level vials, scales, and pointers required for indicating the movement and/or position of the instrument should be readily visible and not subject to damage or displacement.

5.8.7.7 Lighting. Means should be provided for illumination of reticles, internal and external scales, and level vials under low-level conditions which only minimally affect the dark adaptation of the observer. Red illumination or red filters should be used to maintain dark adaptation. Variability of illumination should be provided as required by weapon system characteristics.

MIL-HDBK-759B

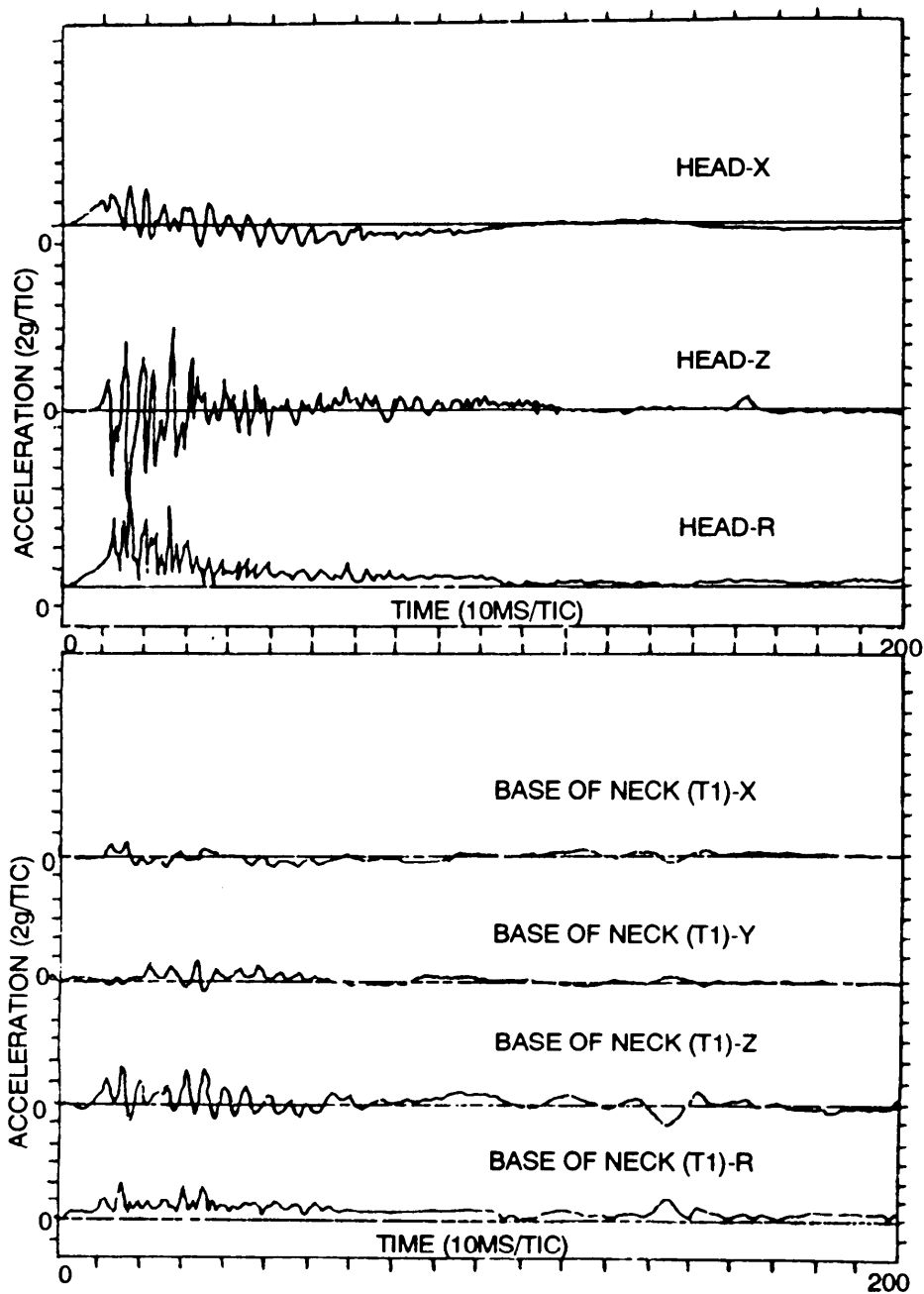

FIGURE 143. Accelerations to human gunner firing 152mm gun from M60A2 tank

MIL-HDBK-759B

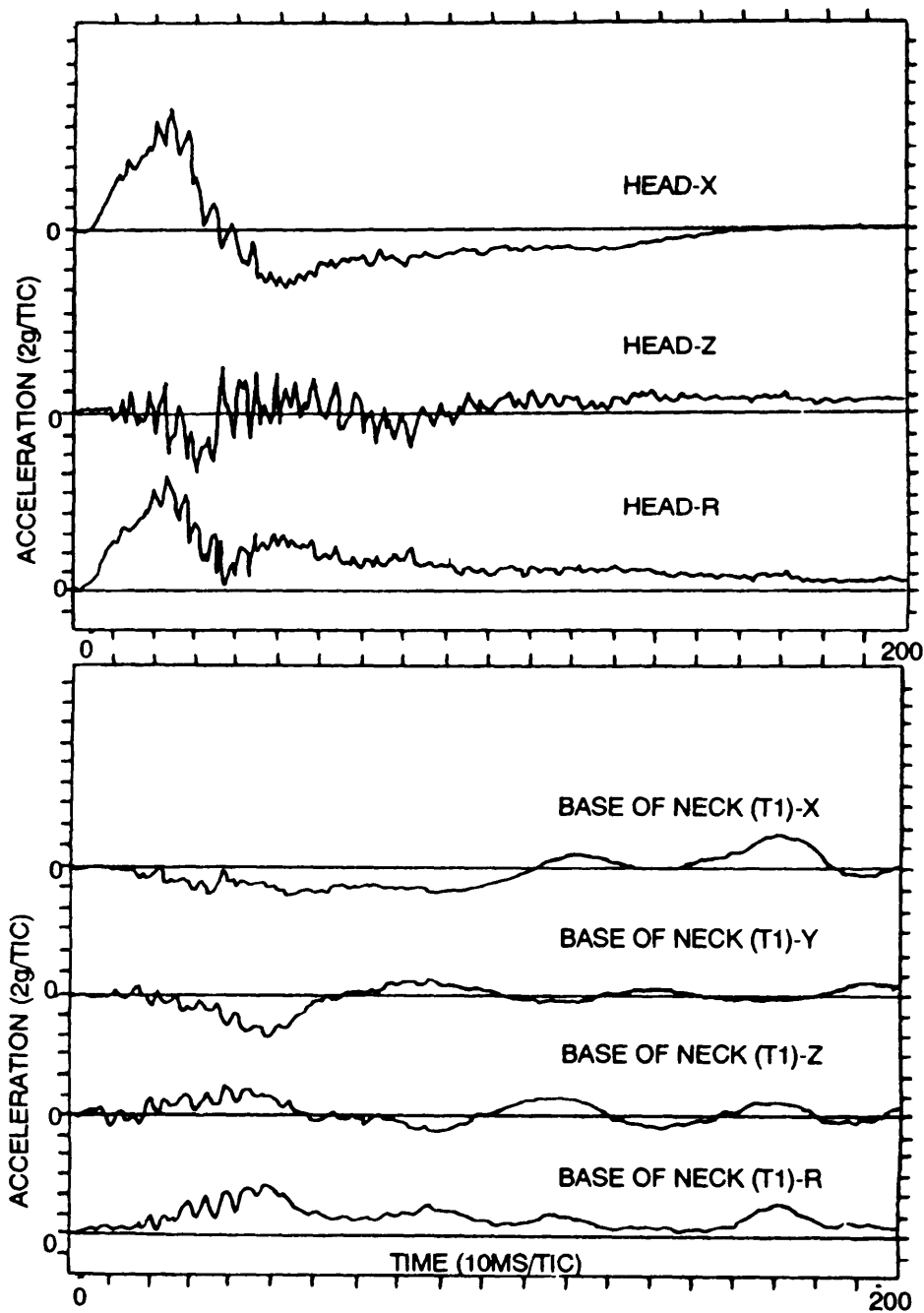

FIGURE 144. Accelerations to human gunner firing 152mm gun from M551 Sheridan vehicle

MIL-HDBK-759B

5.8.7.8 Maintenance.

5.8.7.8.1 Design. When practical, optical equipment should be developed utilizing modular design which will provide for interchangeability of optical subassemblies.

5.8.7.8.2 Sealing. Provision should be made to prevent ingress of moisture, dirt, or fungus spores.

5.8.7.8.3 Maintenance. Instruction plates should be provided on the instrument indicating time intervals, pressure requirements, and time of previous maintenance. In addition, purging and charging fittings should be appropriately identified and easily accessible for required maintenance.

5.8.7.9 Component replacement. Easy access should be provided for components requiring frequent replacement, checkout, or maintenance without the use of special tools or disassembly of other components. Items requiring special tools and/or equipment should have provisions for storage of such special equipment in the near vicinity, preferably on the specific equipment. This particularly applies to items such as light bulbs or other items whose failure could make the instrument inoperable.

5.8.8 Personnel-computer interface. See MIL-HDBK-761, Human Engineering Guidelines for Management Information Systems, or 5.15 of MIL-STD-1472, Human Engineering Design Criteria for Military Systems, Equipment and Facilities.

MIL-HDBK-759B

This Page Intentionally Left Blank.

MIL-HDBK-759B

6. NOTES

6.1 Intended use. This handbook is intended to provide non-binding human factors engineering guidelines, preferred practices, and reference data for design of Army materiel, both in-house and contracted, during any phase of acquisition, as appropriate, to facilitate achievement of objectives stated in Army human factors engineering policy documents. The handbook also serves to provide expanded, supplementary, and Army-relevant human factors engineering information that may be too detailed, lengthy, or service-oriented for inclusion in military standards, such as MIL-STD-1472.

6.2 Subject term [key word] listing.

- Armament
- Anthropometry
- Communications
- Consoles
- Controls
- Displays
- Environment
- Ergonomics
- Hazards
- Labeling
- Maintainability
- Safety
- Vehicles
- Workspace

6.3 Changes from previous issue. Marginal notations are not used in this revision to identify changes with respect to the previous issue due to the extensiveness of the changes.

MIL-HDBK-759B

This Page Intentionally Left Blank.

MIL-HDBK-759B

APPENDIX

ENGLISH EQUIVALENTS AND ABBREVIATIONS

10. GENERAL

10.1 Scope. This appendix provides multipliers to convert from metric (SI) units to inch-pound equivalents

20. APPLICABLE DOCUMENT

20.1 Government Document. The following document forms a part of this appendix to the extent specified.

FEDERAL STANDARD

FED-STD-376 - Preferred Metric Units for General Use by the Federal Government

(Copies of federal and military specifications, standards and handbooks are available from the Naval Publications and Forms Center (ATTN: NPODS), 5801 Tabor Avenue, Philadelphia,, PA 191 20-5099.)

30. DEFINITIONS

This section is not applicable to this handbook.

40. GENERAL GUIDELINES

This section is not applicable to this handbook.

50. DETAILED GUIDELINES

English equivalents and abbreviations used in this handbook are presented by Table 73. Additional information may be found in FED-STD-376.

MIL-HDBK-759B

TABLE 73. English equivalents and abbreviations

<u>TO CONVERT FROM</u>	<u>TO</u>	<u>MULTIPLY BY</u>
Cubic Meters (m ³)	Cubic Feet (ft ³)	+01 3.5315
Meter (m)	Foot (ft)	00 3.2808
Meter (m)	Inch (in)	+01 3.9370
Centimeter (cm)	Inch (in)	-01 3.9370
Millimeter (mm)	Inch (in)	-02 3.9370
Square Meters (m ²)	Square Feet (ft ²)	+01 1.0764
Square Meters (m ²)	Square Inch (in ²)	+03 1.5500
Newton (N)	Ounce (oz)	00 3.5969
Newton (N)	Pound (lb)	-01 2.2480
Newton-Meter (N•m)	Inch-Ounces (in-oz)	+02 1.4161
Newton-Meter (N•m)	Inch-Pounds (in-lb)	00 8.8501
Kilogram (kg)	Pound (lb)	00 2.2046
L u x	Foot Candle (ft-C)	-02 9.2923
Candela/Meter ² (cd/m ²)	Foot Lambert (ft-L)	-01 2.9186
TEMPERATURE CONVERSION: °F = 9/5°C +32		

NOTE: The first two digits on each numerical entry are for conversion multipliers

MIL-HDBK-759B

INDEX

	<u>Paragraph</u>	<u>Page</u>
A		
A-Duration (Definition)	3.1	11
Abbreviations (Label)	5.5.1.3.2	325
Access	5.5.1.4.8	327
	5.6.8	348
Access, Battery	5.8.4.1.2.1	455
Design	5.6.8.2	353
General	5.6.7	347
Vkual	5.6.5.4	346
Whole Body	5.6.5.3	346
Accessibility	5.6.5	345
Brake	5.8.4.2.3.1	457
Accessible (Definition)	3.2	11
Acid, Battery	5.8.4.1.3	455
Adaptation, Dark	5.4.5.3.4	306
	5.4.5.8	308
Advisory Signal (Definition)	3.3	11
Air Conditioning	5.4.2.6	294
Alignment Pins	5.6.9.3.2	357
Ambient Light	3.4	11
	5.4.5.8.2	308
Ammo Chutes	5.8.2.2.5.3	448
Ammunition	5.8.1	443
Hoist	5.8.1.2.1	443
Ready Racks	5.8.1.3.1	443
Stowage Racks	5.8.1.3	443
Upright Mounts	5.8.1.3.3	444
Amplitude (Definition)	3.5	11
Antenna, Radio	5.8.3.7	454
Anthropometry	5.3.2	190
Data	5.3.2.2	191
General	5.3.2.1	190
Anthropometry Measurements		
Arctic Clothed	Table 48	235
	Figure 57	234
Basic Uniform	Table 49	240
Clothed Dimensions	5.3.2.4.2	233
Men	Figures 42-45	196
	Tables 28-31	197
Pilots	Figures 52-56	216
	Tables 38-47	217
Women	Figures 46-51	204
	Tables 32-37	205
Workspaces	Figure 81	284
	Table 57	288
Arm Strength	Figure 64	253
Armament, Primary	5.8.2.1	444
Boresighting	5.8.2.1.4	446
Breech Design	5.8.2.1.1	446
Electrical Components	5.8.2.1.5	446
Expended	5.8.2.1.3	446
Maintenance	5.8.2.1.2	446
Armament, Secondary	5.8.2.2	446

MIL-HDBK-759B

	<u>Paragraph</u>	<u>Page</u>
Assembly/Disassembly	5.8.2.2.3	447
Ground Mount Operation	5.8.2.2.2	447
Removal/Replacement	5.8.2.2.1	446
Solenoids	5.8.2.2.4	447
Armrests	5.3.12.3	275
Auditory	5.2.2.7	162
	5.2.2.7.1.2.4	165
Automation of Functions	5.2.2.4.5.11	149
 B		
B-Duration (Definition)	3.6	11
Backup (Definition)	3.7	11
Ball controls	5.2.1.18.3	102
	Figure 23	103
Batteries	5.8.4.1	454
Electrical	5.6.24.1	417
Battle-Short Switch (Definition)	3.8	11
Bivariate Table	5.3.2.3.8	193
	Table 27	194
Body Measurements, Correlation Between	5.3.2.3.7	192
Bolts	5.6.11.2.5	369
Borders	5.5.1.5.8	329
Boresighting	5.8.2.1.4	446
Brackets	5.6.18.3	388
Brakes	5.8.4.2	456
Air	5.8.4.2.1.1	456
Parking	5.8.4.2.1.3	456
Warning	5.8.4.2.2	456
Brake Adjustment	5.8.4.2.4	457
Brake Maintenance	5.8.4.2.3	456
Breech Design	5.8.2.1.1	446
Brevity	5.5.1.4.1	325
Brightness Ratio	5.4.5.5	307
	Table 61	307
Brow Pads	5.8.5.7	476
	5.8.7.5.5.1	491
 C		
Cabinets	5.5.1.6.2	332
Cables	5.6.16	376
	5.6.24.6	421
Battery	5.8.4.1.4	455
Electrical	5.6.16.3	379
Extension	5.6.16.3.7	380
Routing	5.6.16.4	380
	5.8.3.10	454
Canvas	5.8.4.14	464
Carbon Monoxide	5.4.7.2	312
	5.4.7.5	312
cases	5.6.10	362
	5.6.10.2	365
Catches	5.6.11.2.2	368

MIL-HDBK-759B

	<u>Paragraph</u>	<u>Page</u>
Cathode-Ray Tube (Definition)	3.9	11
Applications	5.2.2.4.1	137
Criteria for Computer-Generated Displays	5.2.2.4.5	146
Criteria for TV Displays	5.2.2.4.3	143
Guidelines	5.2.2.4.2	137
Screen, Burnings of	5.2.2.4.2.12	141
Special Criteria for Sensor Displays	5.2.2.4.4	143
Shape	5.2.2.4.2.14	142
Useful Screen Diameter	5.2.2.4.2.15	142
Viewing Angle	5.2.2.4.2.19	143
Caution Marking and Signals	5.7.2.1.2.2	432
Caution Signal (Definition)	3.10	11
Chain, Retainer	5.6.11.2.12	370
Characters		
Alphanumeric	5.2.2.4.5.2	146
Generation	5.2.2.4.5.2.1	146
Height	5.5.1.5.6	329
Height, Mechanical Counters	Table 23	154
Spacing	5.5.1.5.2	328
Character-Generating Devices	5.2.2.6.2.3	154
Charging	5.8.2.2.5.1	448
Chassis	5.8.4.10	462
Checklist, Cabling/Connectors	5.6.17	383
Equipment Units	5.6.21	400
Equipment Units Access	5.6.12	370
Test Equipment	5.6.23	415
Test Points	5.6.22.2	407
Chemical Warfare Agents	5.4.8	314
Circuit Breakers	5.6.24.2	418
Climate, Effect on Maintenance Personnel	5.6.3	341
Clothing and Personal Equipment	5.3.2.3.5	192
Clutches	5.8.4.3	457
Coarse Settings	5.2.3.8.2	188
Coding	5.6.9.3.4	357
	5.6.18.6	388
Color	5.6.9.3.4.1	357
Controls	5.2.1.1.4	28
Location	5.2.1.1.4.4	31
Number	5.6.9.3.5.1	358
Shape	5.6.9.3.4.2	357
Size	5.2.1.1.4.3	30
	5.6.9.3.4.4	358
Wires	5.6.9.3.5.2	358
	5.6.16.3.2	379
Cold	5.6.3.4.1	342
Colors	5.5.2.2	337
Collective Protection System	5.4.8.2	315
Command and Control System Equipment (Definition)	3.11	12
Commanders Station	5.8.5.9	477
Common Hand Tools (Definition)	3.12	12
Communications	5.8.3	452
Voice	5.2.2.7.3	169
Compartments, Battery	5.8.4.1.1	454
Composite Display	5.2.2.3.5	136
Concentrations, Gases	5.4.7.4	312

MIL-HDBK-759B

	<u>Paragraph</u>	<u>Page</u>
Conductors, Electrical	5.6.9.3.5	358
Hydraulic	5.6.9.3.6.2	361
Pneumatic	5.6.9.3.6.2	361
Connectors	5.6.9	354
Electrical	5.6.9.3	356
Fluid	5.6.9.3.6	358
Gas	5.6.9.3.6	358
Internal	5.6.14.3	375
Plug-in	5.6.9.2.1	356
Quick-Disconnect	5.6.9.2.2	356
Threaded	5.6.9.2.3	356
Consistency	5.2.3.7.2	186
Consoles	5.2.3	173
Dimensions	Table 26	175
Horizontal Wrap-Around	5.2.3.2.1	176
Sit-Stand	5.2.3.2.3	178
Tester	5.6.22.3.9	414
Vertical/Stacked Segments	5.2.3.2.2	176
Content (Labels)	5.5.1.3	325
Control Box	5.8.3.8	454
Control/Display Identification	5.2.3.7.1	185
Control/Display Integration	5.2.3.6	181
Control Entry (Definition)	3.13	12
Controllers, Two-Axis	5.2.1.18	99
Ball Control	5.2.1.18.3	102
Grid/Stylus Devices	5.2.1.18.6	106
Hand Cranks	5.2.1.18.2	99
Isometric	5.2.1.18.4	104
Isotonic	5.2.1.18.5	104
Light Pen	5.2.1.18.8	107
Quickened/Predictor Type	5.2.1.18.9	108
XY	5.2.1.18.7	107
Controls	5.2.1	21
Arrangement and Grouping	5.2.1.1.3	27
Coding	5.2.1.1.4	28
Criteria, General	5.2.1.1	21
Criteria, Selection	5.2.1.1.1	21
Design Characteristics	Table 1	22
Labeling	5.2.1.2	31
Manual Controls	5.5.1.7	332
Movement Characteristics	Table 2	24
Separation Distances	5.2.1.1.2	25
Surfaces	Table 4	28
Surfaces	5.2.3.4	179
Voice Commo Equipment	5.2.2.7.3.2.6	172
Squelch	5.2.2.7.3.2.6.2	172
Volume	5.2.2.7.3.2.6.1	172
Controls, Types of		
Cranks	Figure 1	33
Discrete	5.2.1.13	83
Foot-Operated	5.2.1.9	49
Ganged Controls Knobs	5.2.3.8.6	189
Ganged Controls Knobs	Figure 13	57
Ganged Controls Knobs	Table 8	59
Ganged Controls Knobs	5.2.1.6.10	44

MIL-HDBK-759B

	<u>Paragraph</u>	<u>Page</u>
Hand Cranks	5.2.1.3	31
Handwheels	5.2.1.4	32
	Table 6	35
Keyboards, Keypads, Keysets and Menu Selectors	5.2.1.11	66
Keylocks and Keylock Switches	5.2.1.5	37
Knobs	5.2.1.6	41
	Figure 6	42
Legend Switches	5.2.1.7	45
	Figure 12	47
Levers	5.2.1.8	48
	Table 7	50
Push Button Switches	5.2.12.10	61
	Table 10	63
Push-Pull	5.2.1.14	89
	Table 16	93
Slide Switch	5.2.1.17	96
	Figure 22	100
Touch-Screen	5.2.1.20	108
Two- Axis	5.2.1.18	99
Control/Display Movement Ratio	5.2.3.8	188
Cotter Key	5.6.11.2.9	370
Counters	5.2.2.6.2.2	152
Drum-Type	5.2.2.6.2.2.6	154
Setting	5.2.3.8.5	189
Coupling Device	5.8.4.11	462
Covers	5.6.10	362
	5.6.10.3	365
Crane	5.6.15.3	375
Boom	5.6.15.3.1	375
Cranks	5.2.1.3	31
	Figure 1	33
Crawl Space	5.8.5.2	473
Crew Compartment Safety	5.8.5.6	476
Crew Station, Combat Vehicle	5.8.5	472
Cupolas	5.8.5.4	475
Cushioning, Chair	5.3.12.2	275
 D		
Danger, Markings	5.7.2.1.2.3	432
Signs	5.7.2.1.2.3	432
Data (Definition)	3.14	12
Data Display (Definition)	3.15	12
Data Entry(Definition)	3.16	12
Data Field (Definition)	3.17	12
Data Item(Definiion)	3.18	12
Data Protection (Definition)	3.19	12
Data, Quantized	5.2.2.4.5.1.1	146
Time-Compressed	5.2.2.4.5.1.3	146
Time-Integrated	5.2.2.4.5.1.2	146
Design Criteria, Noise	5.4.6	310
dB (A) (Definition)	3.20	12
Default Value (Definition)	3.21	12
Detents	5.8.1.4.1	444

MIL-HDBK-759B

	<u>Paragraph</u>	<u>Page</u>
Device, Coupling	5.8.4.11	462
Quick Connect-/Disconnect	5.6.11.2.1	368
Retaining	5.6.2.4	340
	5.6.14.2	374
Digit Light Arrays	5.2.2.6.2.1	152
Dimensional Workspace	5.3.1	190
Discharging Devices	5.7.2.1.3.4	433
Discrete Controls	5.2.1.13	83
Toggle Switch	5.2.1.13.1	83
Rocker Switch	5.2.1.13.2	89
Display Format (Definition)	3.22	12
Displays	5.2.2	109
Cathode-Ray Tube	5.2.2.4	137
Composite	5.2.2.3.5	136
Dot Matrix	5.2.2.6.2.3.3	158
Head-Up	5.2.2.3.6	137
Labeling	5.5.1.7	332
Large-Screen	5.2.2.5	150
Moving-Tape	5.2.2.3.4	136
Optical Projection	5.2.2.6.2.6.6	161
Other	5.2.2.6	151
Scalar Indicators	5.2.2.3	122
Speech Input and Auditory	5.2.2.7	162
Surfaces	5.2.3.3	178
Test Equipment	5.6.22.3.4	411
Transilluminated	5.2.2.2	115
Distortion, CRT	5.2.2.4.2.13	142
TV	5.2.2.4.3.4	143
Doors	5.3.8	270
Dot Matrix Displays	5.2.2.6.2.3.3	158
Drains	5.8.4.8	461
Drain Cocks	5.6.26.4	425
Drawers	5.6.14	373
Driver's Station	5.8.5.12	480
Dual Operation	5.2.3.6.2.2	184
Dust	5.4.10	317
Dynamotors	5.6.24.5	421
Effective Temperature (Definition)	3.23	12
Electrical, Cables	5.6.16.3	379
Equipment	5.6.24	417
Hazards	5.7.2	431
Shock	5.7.2.1	431
Wires	5.6.16.3	379
Electrical Overload Protection	5.7.2.1.5	436
Emergency Controls	5.2.1.1.4.1.3	29
Engine	5.8.4.5	459
Environment	5.4	288
Cold	5.4.3	295
Extremes	5.4.1.2	288
Hot	5.4.2	289
Enter (Definition)	3.24	13
Equipment (Definition)	3.25	13

MIL-HDBK-759B

	<u>Paragraph</u>	<u>Page</u>
Equipment, Electrical	5.6.24	417
Handling	5.6.15	375
Ignition	5.6.24.4	420
Mechanical	5.6.25	422
Portable Test	5.6.22.3.7	411
Test	5.6.22.3	409
Equipment Failure (Definition)	3.26	13
Equipment Labeling	5.5.1.6	329
Exhaust Fumes	5.4.7.7	314
Exhaust System	5.8.4.7	460
Expended Rounds	5.8.2.1.3	446
	5.8.2.2.5.2	448
Explosion	5.7.3.5	438
Eyecups	5.8.7.5.4.1	489
Eye Relief	5.8.7.3.5	487
F		
Facilities (Definition)	3.27	13
Fail-safe Design (Definition)	3.28	13
Familiarity (Labels)	5.5.1.4.2	326
Fasteners	5.6.11	366
	5.6.10.1.5	364
	Figure 103	367
Fasteners, Types	5.6.11.2	368
Captive	5.6.11.2.3	369
Fine Setting	5.2.3.8.3	189
Finger (Index) Operated Switch	5.2.1.16.3	95
Finger Strength	Figure 64	253
Fire	5.7.3.3	438
Fire Control Maintenance	5.8.6.4	484
Fire Extinguisher	5.7.3.3.1	438
Flicker (Definition)	3.29	13
	5.2.2.4.2.9	141
Fluid Connector	5.6.9.3.6	358
Fluid Line	5.6.16.2	378
Foot Controls	5.2.1.9.4	56
Foot-Operated Controls	5.2.1.9	49
	Table 8	59
Footrests	5.3.12.4	278
Foot Switches	5.2.1.9.3	55
Forklifts	5.8.4.20.6	471
Frequency Range	5.2.2.7.2.1.1	166
Fuel System	5.8.4.4	458
Fumes, Exhaust	5.4.7.7	314
Weapon	5.4.7.6	314
Toxic	5.7.3.4	438
Functional Grouping (Controls)	5.2.1.1.3.2	27
Fuses	5.6.20.1.6	400
	5.6.24.2	418
Fuzes	5.8.1.4	444
G		
Ganged Control Knobs	5.2.1.6.10	44

MIL-HDBK-759B

	<u>Paragraph</u>	<u>Page</u>
	Figure 11	46
Gaskets	5.6.9.3.6.1	361
Gas Connector	5.6.9.3.6	358
Gas Lines	5.6.16.2	378
Glad Hands	5.8.4.2.3.2	457
Glare	5.2.2.4.2.4	138
	5.4.5.6	307
Glare Recovery	5.4.5.3.3	302
	Figure 62	245
Gloved-Hand	5.2.1.18.6	106
Grid and Stylus Devices	5.2.1.16.4	96
Grip-Actuated Switch	5.7.2.1.4	434
Grounding	5.2.3.6.3	184
Grouping, Functional	5.2.3.6.4	185
Sequential	5.3.11	273
Guardrails	5.6.18.4	388
Guides	5.6.18.4	388
Guide Pins	5.8.6	480
Gun Control Systems, Tank	5.8.5.10	478
Gunner Station, Tank		
 H		
Hand-Held Testers	5.6.22.3.8	413
Hand Strength	Figure 64	253
Hand Cranks (Simultaneously-Operated)	5.2.1.18.2	99
Handles	5.6.13	371
Handle-Mounted Controls	5.2.1.16	94
	Table 17	97
Handling Capacity (Human)	5.3.4	252
Handling Equipment	5.6.15	375
Handrails	5.3.11	273
Handwheels	5.2.1.4	32
	Table 6	35
Hatches	5.8.5.1	472
Escape	5.3.9	272
Hazards, Electrical	5.7.2	431
Head-Up Display (Definition)	3.30	13
		137
Headset and Receiver	5.8.3.4	453
Heat	5.6.3.3	341
Heater	5.8.4.16	464
Helmets		
CVC DH-132	Figure 60	243
M-1	Figure 59	242
PASGT	Figure 58	241
SPH-4	Figure 61	244
High-temperature Parts	5.7.3.2	437
Hinge-Mounted Unit	5.6.20.1.2	398
Hoist	5.6.15.4	376
Holder, Battery	5.8.4.1.1.1	454
Hooks	5.6.15.3.2	376
	5.8.4.15	464
Horns	3.31	13
Human Engineering Design Criteria (Definition)	5.3.3.1	247
Human Motion, Range of	Figure 63	248

MIL-HDBK-759B

	<u>Paragraph</u>	<u>Page</u>
	Table 50	249
Human Strength	5.3.4	252
Human Subjects	5.3.2.4.4.	247
Humidity	5.4.2.5	294
Hydraulic Conductors	5.6.9.3.6.2	361
Hydraulic System	5.6.26	425
Design of	5.6.26.6	426
I		
Identification, Control Display	5.2.3.7.1	185
Ignition Equipment	5.6.24.4	420
Illumination	5.4.5	300
	5.2.3.6.1.7	183
Illumination Levels	5.4.5.3	300
	Table 58	302
	Table 59	303
Implosion	5.7.3.5	438
Indicators, Fixed-Pointer, Moving-Scale	5.2.2.3.3	135
Moving-Pointer, Fixed-Scale	5.2.2.3.2	128
Scalar	5.2.2.3	122
Information (Definition)	3.32	13
Interaction, Operator/Computer	5.2.2.4.5.6	148
Interface, Personnel/Computer	5.8.8	495
Interference, External Viewing	5.2.2.3.6.1	137
Interrupt (Definition)	3.33	13
J		
Jacks	5.6.15.2	375
Jitter	5.2.2.4.2.8	141
Joystick, Isometric	5.2.1.18.4	104
Isotonic	5.2.1.18.5	104
	Figure 24	105
K		
Key, Cotter	5.6.11.2.9	370
Keyboards	5.2.1.11.2	67
	Table 11	68
Keylocks	5.2.1.5.1	37
Criteria	Figure 4	39
Mounting	Figure 3	38
Keylock Switches	5.2.1.5.2	37
Criteria	Figure 5	40
Keypads	5.2.1.11.3	68
Keysets, Dedicated	5.2.1.11.4	70
Multi-function	5.2.1.11.5	70
	Figure 14	72
Knobs	5.2.1.6	41
	Figure 6	42
L		
Label, Background	5.5.1.4.6	326
Control	5.2.1.1.5	31

MIL-HDBK-759B

	<u>Paragraph</u>	<u>Page</u>
Life	5.5.1.4.7	327
Surface	5.5.1.4.9	327
Labeling	5.6.18.6	388
Control/Display	5.5.1.7	332
Equipment	5.5.1.6	329
Test Points	5.6.22.2	407
Wire/Cable	5.6.16.3.2	379
Labels	5.5	322
Ladders	5.3.6.3	263
Ladders, Trailers/Vans	5.3.6	262
Latches	5.8.4.13	463
Latching Mechanisms	5.6.11.2.2	368
Leg Strength	5.8.1.3.4	444
Legend Switches	Figure 65	254
Legends	5.2.1.7	45
Legibility	Figure 12	47
Letters	5.5.1	322
Letter Design	5.5.1.4.4	326
Levers	5.5.1.3.3	325
Lift Capacity	5.5.1.5.1	327
Light, Red	5.2.1.8	48
Light, Ambient	Table 7	50
Light-Emitting Diodes	5.3.4.3	252
Lighting Crew Compartment	5.4.5.3.4	306
Lighting Fixtures	5.4.5.8.3	310
Lighting System	5.4.5.8.2	308
Lights, Identification	5.2.2.6.2.3.2	157
Legend	5.4.5.3.5	306
Simple Indicator	5.8.5.3	475
Signal	5.4.5.4	306
Lines	5.8.4.18	465
Gas Fluid	5.2.2.2.3	120
Line of Sight	5.2.2.2.2	118
Line Spacing	5.2.2.2.3	120
Loaders Station	5.2.2.2.3	120
Loading, Operator	5.6.16	376
Location, Labels	5.6.16.2	378
Loudspeakers	Figure 25	112
Luminance Contrast (Definition)	5.5.1.5.5	329
Luminance Ratio	5.8.5.11	479
Luminance, Screen (CRT)	5.2.2.4.4.6	145
M	5.5.1.2.2	323
Machine-Gun	5.2.2.7.3.2.3.2	171
Magnification	5.8.3.3	453
Maintainability (Definition)	3.34	13
Maintenance	3.35	14
	5.2.2.4.2.1	137
Machine-Gun	5.8.2.3.2	449
Magnification	5.8.7.3.1	486
Maintainability (Definition)	3.36	14
Maintenance	5.6.5	345
	5.6	337

MIL-HDBK-759B

	<u>Paragraph</u>	<u>Page</u>
Maintenance, Battery	5.8.4.1.2.2	455
Effect of Climate	5.6.3	341
Fire Control	5.8.6.4	484
Manuals	5.6.1.3	339
Manual Controls	Table 2	24
	5.8.6.2	481
Marking	5.5	322
	5.6.10.1.6	364
	5.6.18.6	388
Masking	5.8.3.1.1	452
Master Caution (Warning) Signal	3.37	14
Mechanical Equipment	5.6.25	422
Mechanical Flags	5.2.2.6.2.4	159
Mechanical Hazards	5.7.3	437
Menu Selectors	5.2.1.11.6	73
	Figure 15	74
Microphones	5.2.2.7.3.2.2	170
Miniature Controls	5.2.1.19	108
Mirrors	5.8.4.19	470
Motion Sickness	5.4.12.2.5	319
Mounting	5.6.18	386
Wire	5.6.16.3.3.1	379
Mouse (XY Controller)	5.2.1.18.7	107
Movement Characteristics, Controls	5.2.1.1.2	25
Movement Stereotypes, Controls	Table 3	25
Moving-Tape Display	5.2.2.3.4	136
Mud	5.4.11	317
 N		
Nitrogen Oxides	5.4.7.3	312
Noise	5.4.6	310
Facility Design	5.4.6.4	311
Hazardous	5.4.6.2	310
Non-Hazardous	5.4.6.3	310
Noxious Substances	5.4.7	311
Nuclear, Biological, Chemical Survivability (Definition)	3.38	14
Nuts	5.6.11.2.5	369
 O		
Operation, Sequence of	5.2.3.6.3.1	184
Optical Instruments	5.8.7	485
Optical Parameters	5.8.7.3	486
Optical Projection Displays	5.2.2.6.2.6.6	161
Orientation, Labels	5.5.1.2.1	323
 P		
Packaging	5.6.18	386
Panel, Transilluminated	5.2.2.2.4	121
Panels	5.5.1.6.3	332
Partitions, Battery	5.8.4.1.1.4	455
Passageways	5.3.7	270
Peak Pressure Level (Definition)	3.39	14
Pedals	5.2.1.9.4	56

MIL-HDBK-759B

	<u>Paragraph</u>	<u>Page</u>
Perforations	5.7.3.2.1.1	437
Periscopes	5.8.5.8	477
Persistence (CRT)	5.2.2.4.2.6	138
Personnel-Computer Interface	5.8.8	495
Pin, Alignment	5.6.9.3.2	357
Guide	5.6.18.4	388
Pin Configuration	Figure 101	360
Placards	5.5.1	322
Platforms	5.3.10	273
Plotters	5.2.2.6.2.5	159
Pneumatic Cotudors	5.6.9.3.6.2	361
Portable Test Equipment	5.6.22.3.7	411
Power	5.8.3.1.2	452
Cables	5.6.9.3.5.2.3	358
Controls	5.8.6.3	482
Frequency, Avoidance of	5.2.2.7.2.1.2	166
Primary Controls (Definition)	3.40	15
Printed Circuit Switch	5.2.1.1.3.1	27
Printers	5.2.1.15	94
Production Systems	5.2.2.6.2.6	160
Projectile, Handling	5.5.1.1.3	323
Storage	5.8.1.1.1	443
Transfer	5.8.1.1	443
Protective Ensemble	5.8.1.2	443
Prototype Systems	5.4.8.3	316
Push button, Hand Operated	5.5.1.1.3	323
Table 9	5.2.1.10	61
Table 10	Table 9	62
Table 16	Table 10	63
Push-Pull Controls	5.2.1.14	89
Table 16	Table 16	93
Push-Pull Forces	5.3.4.2	252
Horizontal	5.3.4.2.1	252
Table 51	Table 51	255
Vertical	5.3.4.2.2	252
Table 52	Table 52	256
Q		
R		
Racks	5.6.14	373
Rack, Mounting (Battery)	5.8.4.1.1.2	455
Radiation	5.4.9	316
Ionizing	5.7.3.7	439
Microwave	5.4.9.2	317
Non-ionizing	5.7.3.7	439
Nuclear	5.4.9.3	317
Radiators	5.8.4.6	460
Radio Antenna	5.8.3.7	454
Radio Set	5.8.3.6	453
Ramps	5.3.6	262
5.3.6.5	5.3.6.5	267
Range Rings	5.2.2.4.4.2	144
Receiver	5.8.3.4	453
Receptacles, Battery	5.8.4.1.1.5	455

MIL-HDBK-759B

	<u>Paragraph</u>	<u>Page</u>
Recognition, Individual Speaker.....	5.2.2.7.1,2,2	163
Speech	5.2.2.7.1.2.3	165
Recorders	5.2.2.6.2.5	159
Red Light	5.4.5.3.4	306
	5.4.5.8.3	310
Reflectances	5.4.5.7	308
Reflection, CRT.....	5.2.2.4.2.4	138
Relays	5.6.24.3	419
Remote Controls	5.2.1.1.3.5	27
Replaceable Units.....	5.6.19	394
Retainer Chains.....	5.6.11.2.12	370
Retainer Ring	5.6.11.2.11	370
Retaining Devices.....	5.6.2.4	340
	5.6.14.2	374
Retitles.....	5.8.7.3.8	488
Rifles	5.8.2.3.2	449
Rise Time (Definition)	3.41	15
Rivets	5.6.11.2.8	370
Rocker Switch	5.2.1.13.2	89
	Figure 21	91
Rotary Controls.....	5.2.1.12	73
Discrete	5.2.1.12.1	73
Rotary Selector Switches	5.2.1.12.1.1	73
	Table 14	77
 S		
Safety	5.7	428
Equipment and Personnel	5.6.20.1.1	397
Safety Checklist.....	5.7.4	439
Scales, Circular.....	5.2.2.3.2.3	129
	5.2.2.3.3,2	135
Curved	5.2.2.3.2.4	131
Fixed-Pointer, Moving-Scale.....	5.2.2.3.3	135
Horizontal Straight.....	5.2.2.3.2.4	131
	5.2.2.3.3.3	136
Moving-Pointer, Fixed-Scale	5.2.2.3.2	128
Non-Linear	5.2.2.3.3.5	136
Vertical Straight	5.2.2.3.2.4	131
	5.2.2.3.3.3	136
Screws.....	5.6.11.2.4	369
Seals	5.6.9.3.6.1	361
	5.6.26.5	426
Seat Reference Point (Definition)	3.42	15
Seats, Temporary	5.3.12.5	278
Seating	5.8.4.17	465
	Figure 138	466
	Figure 139	468
	Table 72	469
Separation Distances, Controls.....	Table 4	28
Sequential Grouping Controls	5.2.1.1.3.3	27
Servicing, Battery	5.8.4.1.2	455
Setting, Coarse vs Fine	5.2.3.8.1.1	188

MIL-HDBK-759B

	<u>Paragraph</u>	<u>Page</u>
Shields	5.6.10	362
Shielding, Metallic	5.6.16.3.6	380
Shock, Electrical	5.7.2.1	431
Shock Mounts	5.6.18.5	388
Signals, Advisory	5.2.2.7.2.2	167
Alerting	5.2.2.7.2.4	167
Audible	5.8.3.1.3	452
Caution	5.2.2.7.2.5	168
Cueing	5.2.2.7.2.3	167
Prohibited Types	5.2.2.7.2.1.6	167
Warning	5.2.2.7.2.6	168
Signs	5.5.1	322
Size Coding, Controls	5.2.1.1.4.3	30
Knobs	5.2.1.6.5	41
Slide Switches	5.2.1.17	96
	Figure 22	100
Slump Factor	5.3.2.4.3	247
Small Arms	5.8.2.3	448
Solenoids	5.8.2.2.4	447
Spacing, Character	5.5.1.5.2	328
Line	5.5.1.5.5	329
Word	5.5.1.5.3	328
Speech Input and Audio Display	5.2.2.7	162
Speech Masking	5.8.3.1.1	452
Stacking	5.6.20.1.3	398
Stairs	5.3.6	262
	5.3.6.4	267
Standard Tools (Definition)	3.43	15
Stowage	5.6.2	339
Areas/Boxes	5.6.2.5.3	340
Straps	5.6.18.3	388
Stroke, Continuity	5.5.1.5.1.4	328
Width	5.5.1.5.1.3	328
Subfunctions	5.5.1.6.4	332
Surface Temperatures	5.4.4.5	299
Switches, Battle-Short	5.7.2.1.3.2	433
Finger-Operated	5.2.1.16.3	95
Grip-Actuated	5.2.1.16.4	96
	5.7.2.1.3.3	433
Push-Button	5.2.1.10	61
	Table 9	62
	Table 10	63
Printed-Circuit	5.2.1.15	94
Rocker	5.2.1.13.2	89
Rotary Selector	5.2.1.12.1.1	73
Slide	5.2.1.17	96
Thumb	5.2.1.16.2	95
Thumbwheel	5.2.1.12.1.2	76
Toggle	5.2.1.13.1	83
Symbols (and Modifiers)	5.2.2.4.5.3	147
Systems, Production	5.5.1.1.3	323
Prototype	5.5.1.1.3	323

MIL-HDBK-759B

	<u>Paragraph</u>	<u>Page</u>
T		
Tactual Recognition (Definition)	3.44	15
Knobs	5.2.1.6.6	41
Talkers	5.8.3.5	453
Tanks (Thermal Considerations)	5.4.4.4	299
Tank Gun Control Systems	5.8.6	480
Telegraph Wire	5.6.9.3.5.2.2	358
Telephone	5.8.3.2	452
Wire	5.6.9.3.5.2.2	358
Teletype Wire	5.6.9.3.5.2.2	358
Temperature, Effective	5.4.2.2	289
Surface	5.4.4.5	299
Wet Bulb Globe	5.4.2.3.1	293
Terminals, Battery	5.8.4.1.5	456
Test Equipment	5.6.22.3	409
Test Points	5.6.22	401
.....	5.6.9.3.3	357
Testers, Console	5.6.22.3.9	414
Hand-Held	5.6.22.3.8	413
Thermal Considerations, Vehicle	5.4.4	297
Thermal Tolerance	5.4.2.4	293
Thumb Strength	Figure 64	253
Thumb Switch	5.2.1.16.2	95
.....	Table 17	97
ThumbWheel Switch	5.2.1.12.1.2	76
.....	Figure 17	81
.....	Figure 18	82
Tire, Spare	5.8.4.12	462
Toggle Switch	5.2.1.13.1	83
.....	Table 15	85
Tools	5.6.4	344
Tools, Safety	5.6.4.3	345
Special	5.6.4.1.2	344
Toxic Fumes	5.7.3.4	438
Transillumination (Definition)	3.45	15
Transilluminated Displays	5.2.2.2	115
Identification Lights	5.2.2.2.3	120
Legend Lights	5.2.2.2.2	118
Panel Assemblies	5.2.2.2.4	121
Signal	5.2.2.2.3	120
Simple Indicator Lights	5.2.2.2.3	120
Travel Locks	5.8.5.5	475
Triggers	5.2.1.16.3	95
Tubes	5.6.20.1.5	398
Type Style	5.5.1.5.1.1	327
U		
Understandability, Label	5.5.1.4.3	326
V		
Valves, Check (Brake)	5.8.4.2.3.3	457
Vehicle Personnel Compartment	5.4.4.2	299

MIL-HDBK-759B

	<u>Paragraph</u>	<u>Page</u>
Vehicle, Thermal Considerations	5.4.4	297
Towed	5.8.4.2.1.2	456
Ventilation	5.4.7.7.3	314
	5.7.3.2.1	437
Ventilation, Battery	5.8.4.1.1.3	455
Vents	5.8.4.8	461
Vibration	5.2.2.1.4.5	112
	5.4.12	317
Vibration Limits	5.4.12.2	317
Comfort Level	5.4.12.2.4	319
Equipment	5.4.12.3	319
Motion Sickness	5.4.12.2.5	319
Safety	5.4.12.2.2	319
Whole Body	5.4.12.2.1	317
Viewing Angle	5.2.2.5.3	150
	5.2.2.6.2.3.3.5	158
Viewing Distance	5.2.2.1.4.6	112
	5.2.2.5.4	150
Visibility	5.5.1.4.4	326
Vision Blocks	5.8.5.8	477
Visual Field	Figure 26	114
Visual Parameters	5.8.7.2	485
 W		
Walkways	5.3.7	270
Warning Signal (Definition)	3.46	15
Water	5.4.11	317
Weapon Fumes	5.4.7.6	314
Wet Bulb Globe Temperature (Definition)	3.47	15
White Light (Definition)	3.48	16
Windchill	5.4.3.1	295
	5.6.3.4.2	343
	Figure 85	296
Windows	5.8.4.22	472
Windshields	5.8.4.20	471
Windshield Wipers	5.8.4.21	471
Wue	5.6.16.3.5	379
Electrical	5.6.16.3	379
Safety	5.6.11.2.10	370
Telephone, Teletype and Telegraph	5.6.9.3.5.2.2	358
Wire Coding	5.6.9.3.5.2	358
Wiring	5.6.24.6	421
Word Spacing	5.5.1.5.3	328
Workstation Entrance/Exit	5.3.5	262
Work Positions, Common	5.3.15	281
	Figure 81	284
	Table 57	288

MIL-HDBK-759B

Workspace	5.3.1	190
Criteria	5.6.6	347
Mobile	5.3.14	281
	Table 56	283
	Figure 80	282
Noise Criteria	5.4.6.2	310
Seated	5.3.12	275
	Figure 77	276
	Table 54	277
Standing	5.3.13	278
	Table 55	281
	Figure 79	280
X		
XY Controller (Mouse)	5.2.1.18.7	107
Z		

