

JAN-T-171

30 DECEMBER 1944

JOINT ARMY-NAVY SPECIFICATION TOLUENE

Army Number
50-11-38E

Navy Number
52T7a

This specification was approved by the War Department and the Navy Department for use of procurement services of the Army and the Navy and supersedes the following specifications:

U. S. Army
50-11-38D
12 Feb. 1943

Navy Department
52T7
1 Sept. 1938

A. APPLICABLE SPECIFICATIONS.

A-1. The following specifications, of the issue in effect on date of invitation for bids, form a part of this specification.

JOINT ARMY-NAVY SPECIFICATIONS

JAN-P-110—Packaging and Packing for Overseas Shipment—Drums; Metal, 55 Gallons (For Other than Petroleum Products).

JAN-P-124—Packaging and Packing for Overseas Shipment—Cans and Pails, Metal.

U. S. ARMY SPECIFICATIONS

8-181—Enamel, Olive Drab, Rust-Inhibiting.

50-0-1—General Specification for Ammunition except Small Arms Ammunition.¹

100-2—Standard Specification for Marking Shipments by Contractors.

NAVY DEPARTMENT SPECIFICATION

General Specifications for Inspection of Material.²

INTERSTATE COMMERCE COMMISSION SPECIFICATIONS

5B—Steel Barrels or Drums.

17E—Steel Drums.

MARINE CORPS SPECIFICATION

Cans, One-Gallon; and Cases Shipping for Packing Shellac, Fire-Extinguishing Liquid, Paint Driers, Varnish, Oils, Disinfectant, etc.

¹ Applicable only to Army purchases.

² Applicable only to Navy purchases.

B. GRADES.

B-1. This specification covers the following grades of toluene as specified in the contract or order (see par. H-2).

Grade A—Nitration toluene.

Grade B—Pure commercial toluene.

C. MATERIAL AND WORKMANSHIP.

C-1. See section E.

D. GENERAL REQUIREMENTS.

D-1. See section E.

E. DETAIL REQUIREMENTS.

E-1. *Insoluble material.*—Grade A and grade B toluene shall contain a maximum of 0.10 percent insoluble material.

E-2. *Color.*—The color of grade A and grade B toluene shall be not darker than a standard solution of potassium dichromate (see par. F-4b).

E-3. *Sulfur content.*—Grade B toluene shall be free from hydrogen sulfide and sulfur dioxide.

E-4. *Paraffin hydrocarbons.*—The paraffin hydrocarbon present in by product coke plant grade A toluene shall not exceed 1.5 percent when tested by the method described in paragraph F-4c. All other grade A toluene shall not exceed a maximum of 1.0 percent in this respect.

E-5. *Specific gravity.*—The specific gravity at 15.5° C./15.5° C. shall be as follows:

Grade A—0.8690 to 0.8790 (toluene in the range 0.8690 to 0.8699 is acceptable if the paraffin hydrocarbon content is 1.0 percent or above.)

Grade B—0.864 to 0.874.

E-6. *Acidity.*—The residue after distillation of grade B toluene shall contain no free mineral acid.

E-7. *Separated water.*—Grade A and grade B toluene shall show no separated water (except as permitted in par. F-4f.)

E-8. *Cloud point.*—Grade A toluene, shall show no cloudiness at 80° C.

E-9. *Water test (dryness).*—Grade B toluene shall show no turbidity when mixed with 19 volumes of 60° Baume gasoline (see par. F-4g).

E-10. *Color or acid wash.*—The color of the acid layer of grade A and grade B toluene shall be not darker than Standard No. 2 (see par. F-4i).

E-11. *Copper corrosion.*—Grade B toluene shall not blacken or corrode clean metallic copper in 30 minutes at the boiling point.

E-12. *Distillation range.*—Distillation ranges shall be as follows:

Grade A—The toluene shall distill from first drop to dry point within 1° C. which range shall include either or both the temperature 110.6° and 110.7° C.

Grade B—The toluene shall distill from first drop to dry point within 8° C., which range shall be completely within the limits of 107.5° and 112.5° C.

F. METHODS OF SAMPLING, INSPECTION, AND TESTS.

F-1. *Size of lots.*—Unless otherwise specified in the contract or order, lots shall be 75,000 pounds maximum. When shipment is made in tank cars, one car shall constitute a lot.

F-2 Sampling.—

F-2a. Other than carload lots.—If the material is shipped in drums or other small containers, a minimum of 10 percent of the containers in the lot shall be selected in such a manner as to be representative of the lot. When lots comprise less than 100 containers, 10 containers or all containers in the lot shall be selected. One quart shall be removed from each container and labeled so that the container from which it was taken can be identified. Equal portions shall be removed from the primary samples to make a composite sample of 1 quart. The composite sample shall be mixed thoroughly.

F-2b. Carload lots.—When the absence of separated water has been established (see par. F-4f), approximately 2 quarts from each car shall be removed by means of a weighted bottle. The bottle shall have a capacity of approximately 2 quarts and shall be rinsed thoroughly with the material being sampled. The weighted unstoppered bottle shall be lowered by means of a cord, chain, or rod to the bottom of the shell and immediately withdrawn to the surface. In order to obtain a representative cross section sample, the speed of lowering and raising shall be of uniform rate and regulated so that the bottle is just filled as it reaches the surface of the liquid. All samples shall be placed in glass bottles with glass stoppers or caps containing a cork or cardboard liner covered with metal foil. Each bottle shall be labeled to show the name of the material, manufacturer, plant, contract, or order number, lot number and number of pounds in each lot. All acceptance tests shall be made on the composite sample representative of the lot. The primary samples shall be held by the inspector for possible future examination.

Note.—Precaution: Toluene is subject to deterioration by the action of sunlight. This type of deterioration can be prevented by storing toluene samples in amber colored bottles or in a dark room.

F-3. Inspection.—Inspection shall be made at the point of delivery unless otherwise specified in the contract or order.

F-4. Tests.—The following tests shall be made at a Government laboratory unless otherwise specified in the contract or order.

F-4a. Insoluble material.—Mix the sample thoroughly and pour 115 ± 0.5 ml, equivalent to approximately 100 gm, through a tared filtering crucible (Gooch or "fritted" glass crucible No. 4). Dry the crucible at 100° C. for 1 hour, cool in a desiccator and weigh. Calculate any increase in weight as percentage of insoluble material.

F-4b. Color.—Prepare a solution containing 0.008 gm. of potassium dichromate per liter of distilled water. Make a direct comparison of the color of this solution and that of the sample, using Nessler tubes as the containers.

F-4c. Paraffin hydrocarbons.—Pipette 10 ml. of the sample into a Babcock milk-test bottle having a neck graduated in 8 large divisions, with each large division graduated in 10 small divisions, each of which is equivalent to 0.02 ml. Add 20 ml. of Kattwinkel reagent.¹ Place a stopper in the bottle, immerse it in an ice bath, and shake until most of the reaction has taken place as indicated by a decrease

¹ **Kattwinkel reagent.—**Add 450 gm. of reagent grade phosphorous pentoxide in small portions to 815 ml. of 98.5 ± 0.5 percent sulfuric acid. Allow the mixture to stand until the supernatant liquid is clear, and decant the solution from the residue. Particles of carbonaceous matter which have precipitated out in the solution should be removed by filtering the Kattwinkel reagent through glass wool.

in the amount of heat generated. Then shake more vigorously and continue this until no more unsulfonated toluene is visible. Remove the bottle from the ice bath and shake occasionally during the next 10 minutes. Control the cooling and agitation of the sample so that the temperature does not rise above 50° C. during the sulfonation period. Add approximately 2 ml. of water at a temperature of 25° to 35° C., quickly place a finger over the mouth of the bottle, and agitate the solution. Repeat this procedure until the bulb of the bottle is filled, allowing the temperatures of the solution to be increased to 60° to 90° C. by the first few additions of water. Follow these directions carefully in order to avoid crystallization. During the procedure, keep the neck of the bottle cool and the mouth of the bottle closed as much as practicable in order to prevent loss of paraffin hydrocarbons. Without shaking the bottle, add enough water to bring the level of the liquid well up into the neck of the bottle. Place a stopper in the bottle and centrifuge it at approximately 1,000 revolutions per minute until there is no further increase in the volume of the separated paraffin hydrocarbons. If appreciable separation of crystals has taken place before centrifuging is complete, disregard the results and repeat the determination. Note the volume of the paraffin hydrocarbon layer. Calculate this to percentage by volume, and add a correction of 0.2 percent to obtain the percentage of paraffin hydrocarbons in the sample.

F-4d. Specific gravity.—Determine the specific gravity at 15.5° C./15.5° C. by means of a standardized hydrometer, Westphal balance, or specific gravity bottle.

F-4e. Acidity, mineral acid (residues after distillation).—The cooled residue from the distillation flask shall be collected in a test tube. Add 3 volumes of distilled water and shake the tube thoroughly. Allow the mixture to separate. Remove the aqueous layer to a clean test tube by means of a pipette. Add 1 drop of methyl orange solution. No pink or red color will form provided no free mineral acid is present.

F-4f. Separated water.—

F-4f(1). Laboratory examination.—Visual examination of the laboratory sample shall show no evidence of separated water.

F-4f(2). Examination during sampling.—Examine for the absence of separated water by smearing on the end of a measuring stick some water finding paste. Insert the stick into the container and allow it to remain for approximately 30 seconds. Examine the water detector for the presence of water, indicated by a change in color. The bottom edge of the detector shall show no more than a trace of water. If the material is shipped in tank cars, establish the absence of water by lowering vertically to the bottom of the shell of each car, but not into the sump, a suitable measuring stick or plumb-bob on which has been smeared some water finding paste. Allow the detector to remain at the bottom for about 30 seconds, withdraw and read the depth present. Separated water in excess of 1/2 inch shall be cause for rejection.

F-4g. Water test (dryness).—Transfer 5 ml. of the sample to a 100 ml. glass-stoppered cylinder. Add 60° Baume gasoline in 5 ml. portions at 20° C. (68° F.) Shake well after each addition. Continue additions until a permanent turbidity appears. Report the volume of gasoline required to produce turbidity.

F-4h. Cloud point.—Place 100 ml. of sample in a 100 ml. graduate or standard oil sample bottle and cool or heat to 30° C. The sample shall show no cloudiness at 30° C. indicating a minimum amount of dissolved or occluded water.

F-4i. Color of acid wash.—Heat or cool 98 percent sulfuric acid and toluene in separate containers to within $\pm 5^\circ$ F. of the temperature of the standard colors as indicated by the room temperature wherein the standard colors are kept and the test is conducted. Place 7 ml. of 98 percent sulfuric acid in a square, flint glass-stoppered bottle of approximately 30 ml. capacity. Add 21 ml. of the sample, shake vigorously for 20 seconds in such a manner that no yellow tinge or yellow shade remains in the toluene layer and allow to stand for 15 minutes. This result can best be attained by shaking very rapidly through a short arc (approximately 6 inches) and changing the plane of the arc from the vertical to the horizontal during shaking. If a dark layer forms at the junction of the toluene and acid layers during the 15 minutes standing, it should be distributed throughout the acid layer by swirling before comparison with the standard colors. Compare the resulting color of the acid layer with a set of standard colors, and note the corresponding standard. If the color of the acid layer is between two color standards, report the results, as 0-1, 1-2, etc. To make up the set of standards, prepare the following stock solutions:

Solution 1. Dissolve 59.497 gm. of cobalt chloride $\text{CoCl}_2 \cdot 6\text{H}_2\text{O}$ (nickel, 0.15 percent maximum) in a mixture of 800 ml. of distilled water and 25 ml. of 31 percent hydrochloric acid. Transfer the solution to a 1-liter volumetric flask, dilute to the mark with distilled water, and mix.

Solution 2. Dissolve 45.054 gm. of ferric chloride $\text{FeCl}_3 \cdot 6\text{H}_2\text{O}$ in a mixture of 800 ml. of distilled water and 25 ml. of 31 percent hydrochloric acid; dilute to 1 liter with distilled water, and mix.

Solution 3. Mix 3.5 volumes of solution 1 with 36.5 volumes of solution 2 and 90 volumes of distilled water.

Solution 4. Mix 3.5 volumes of solution 1 with 36.5 volumes of solution 2. Prepare the following standard colors and seal them in square flint glass bottles:

- No. 0. Pure distilled water.
- No. 1. One volume of solution 3 plus 1 volume of water.
- No. 2. 5.5 volumes of solution 3 plus 2 volumes of water.
- No. 3. Solution 3.
- No. 4. One volume of solution 4 plus 1 volume of water.
- No. 5. 5.5 volumes of solution 4 plus 2 volumes of water.
- No. 6. Solution 4.

F-4j. Copper corrosion.—Place a clean strip of mechanically polished pure sheet copper, approximately $\frac{1}{2}$ inch wide and 3 inches long, in a glass test tube approximately $\frac{3}{4}$ inch in diameter and 8 inches long. Add sufficient of the sample to be tested to completely cover the strip and heat rapidly to boiling (it is most convenient to heat the tube by immersion in an oil bath maintained at a temperature slightly higher than the initial boiling point of the material being tested). Keep the sample boiling without any actual distillation taking place for 30 minutes and then examine the copper strip for blackening. A slight tarnish shall be disregarded, but any marked blackening or iridescence shall be cause for rejection.

[JAN-T-171]

F-4. Sulfur content.—A qualitative test for hydrogen sulfide and sulfur dioxide shall be made at the time of the distillation test. Hang strips of moistened lead acetate paper and starch iodate paper on the end of the condenser tube. Discoloration of lead acetate paper indicates presence of sulfur dioxide. To pass this test neither paper shall show any discoloration.

F-4. Distillation range.—

F-4(1). Apparatus.—

F-4(1)a. Distilling flask.—Use a 200 ml. side-tube distilling flask having the following dimensions:

	Normal	Tolerance
Diameter of bulb, outside.....	73 mm.	±1.5 mm.
Diameter of neck, inside.....	21 mm.	±1.0 mm.
Height of flask, outside.....	179 mm.	±2.0 mm.
Vertical distance, bottom of bulb outside to horizontal tangent at side tube.....	120 mm.	±2.0 mm.
Length of side tube.....	127 mm.	±3.0 mm.
Diameter of side tube, inside.....	5 mm.	±0.25 mm.
Angle of side tube with vertical axis of bulb and neck.....	75 degrees to 80 degrees	

F-4(1)b. Condenser tube.—Use a condenser tube made from a 23-inch length of 0.44 to 0.56 inch outside diameter glass tubing, flared at one end to approximately 0.75 inch outside diameter and cut off square at the other end. This condenser tube shall be set in a cooling bath, as shown on figure 1.

F-4(1)c. Shield.—Use a distillation shield constructed of sheet metal of approximately 0.0312 inch thickness (22 gage) as shown on figure 1. This shield shall be 8 inches square and 21 inches high. There shall be an opening in one face of the shield for the condenser tube. This opening shall be 1 by 2.5 inches in size and the center of this opening shall be 4 inches from the sides and 13.75 inches from the base. A door in the front of the shield shall extend to 11.5 inches above the bottom. The upper front portion of the shield above the door shall be fitted with vertical guides so that an 8-inch square of wire reinforced glass may slide in and out.

F-4(1)d. Ring support and asbestos board.—Use a ring support of the ordinary laboratory type approximately 4 inches in diameter, supported on a stand inside the shield. Use a 6-inch square transite or asbestos board, 0.25 inch thick and having a 1-inch circular opening in the center. This board shall be placed on the ring to support the distilling flask.

F-4(1)e. Gas burner.—For supplying heat use an ordinary Bunsen or Tirrell burner, having a sensitive regulating valve.

F-4(1)f. Distillation thermometer.—Use a mercury in glass thermometer with etched stem, centigrade scale, having a range 95° to 160° C., graduated in 0.2° C., numbered every 2° C., plain front and white enameled back. The bulb shall be of Corning normal glass or equivalent and the calibration shall be for total immersion. The expansion chamber shall accommodate expansion of the mercury to 200° C. and shall have no capillary tail. The contraction chamber shall have its maximum diameter in the center of the stem and its top not more than 44 mm. above the bottom of the thermometer bulb. The total length of graduated portion shall be 283±20 mm. and the graduations shall begin 75±5 mm. above the bottom of the bulb. The ac-

curacy shall be certified to be within 0.2° C. throughout the range of the thermometer. Alternative type to conform as follows:

Type.—Mercury in glass, etched stem, total immersion, filling above the mercury—nitrogen or other inert gas.

Range and total length.—70° to 120° C. (300 to 365 mm.) or 70° to 150° C. (350 to 360 mm.).

Stem.—Plain front, enamelled back, suitable thermometer tubing 6 to 7 mm. in diameter.

Bulb.—Corning normal or equally suitable thermometric glass. Length 12 to 20 mm. Diameter not less than 5 mm. and not larger than the stem.

Distances to the 70-degree mark.—85 to 95 mm. Distance to 120-degree or 150-degree mark from top of thermometer. 40 to 60 mm.

Contraction chamber.—Top to be not more than 40 mm. above the bottom of the bulb. The mercury shall stand near the bottom of the chamber at 0° C.

Expansion chamber.—To permit heating the thermometer to 200° C.

Graduations.—All lines, figures, and letters to be clear cut and distinct. The first and each succeeding degree line to be longer than the remaining fractional-degree lines. Graduations to be every 0.2° C. and numbered every 2° C.

Marking.—Serial number and manufacturer's name or trade-mark to be etched on the stem.

Scale error.—The error at any point on the scale not to exceed 0.4° C.

Standardization.—The thermometer to be standardized for total immersion and the bore correction certified by the manufacturer. Routine test thermometers without ice points shall be frequently compared with a master standard which has an ice point and which has been originally calibrated for total immersion by the U. S. Bureau of Standards. (Frequent comparisons are important, especially in the early life of the routine thermometer when it is most subject to change.) Make the comparison of test and master standard thermometers by immersing each to the depth of its mercury column (100° C.) in the same container of boiling water. The true temperature of the boiling water will be the temperature read by the master thermometer after applying the ice-point correction previously determined in an ice bath. The difference in the reading (corrected) of the master and the test thermometer is the correction to be applied to the test thermometer.

F-41(1)g. Correction thermometer.—Use any suitable type mercury in glass thermometer having a centigrade scale including the range 10° to 100° C. and being graduated 1° C.

F-41(1)h. Graduate.—Use an ordinary 100 ml. graduated cylinder.

F-41(2). Procedure.—After assembling the distillation apparatus as shown on figure 1, fill the condenser cooling box with cold water not below the dew point temperature of the atmosphere, so as to avoid wetting of the interior of the condenser by the condensation of atmospheric moisture. Maintain the condenser bath at a temperature just above the dew point of the atmosphere throughout the distillation by the occasional addition of small amounts of ice or the steady flow of water of the correct temperature. Swab out the condenser tube to remove any liquid remaining from a previous test using a piece of soft lint-free cloth attached to a cord or copper wire. Rinse out the distilling flask with two 20 to 30 ml. portions of the sample and allow it to drain for 30 seconds. Measure these portions from the same graduate which is to be used to receive the dis-

distillate. Measure 100 ml. of the sample in this graduate and transfer it to the distillation flask, allowing the cylinder to drain for 30 seconds. Place the graduate, without drying, under the delivery end of the condenser. Insert a well-rolled perforated cork stopper into the flared end of the condenser tube. Insert the side arm of the distillation flask through the perforation in the stopper so that the end of the side tube extends at least 1.5 inches into the condenser beyond the end of the cork. Insert the distillation thermometer into the flask in the position shown on figure 2, making sure that the top of the contraction chamber is even with the bottom of the side arm of the flask and that the bottom of the main mercury bulb of the thermometer is not lower than the upper limit of the extended circumference of the bulb of the flask. Attach the correction thermometer to the distillation thermometer with rubber bands so that the bulb of the correction thermometer is against the distillation thermometer and approximately in the center of the emergent mercury column when a reading is taken. Just before the application of heat make certain that the distillation flask is firmly seated on the 1-inch hole in the transite or asbestos board, so that the heat is applied directly to this limited area of the flask only and not around the side of the flask, in order to prevent errors due to superheating of the toluene vapors. Finally apply heat to the distillation flask, through the opening in the transite board, at a uniform rate so regulated that ebullition occurs in not less than 5 nor more than 10 minutes after heating is begun. Observe the position of the ring of condensing vapor in the flask and adjust the heating so that this ring climbs slowly and steadily, requiring not less than 90 seconds and preferably approximately 120 seconds to rise from the bottom of the neck of the flask to the bottom of the side arm. Observe strictly the above-prescribed time limits, since accurate results can be secured only in this way, allowing sufficient time for the thermometer to reach equilibrium at the initial boiling point of the sample. Record the reading of the thermometers at the moment when the first drop of the distillate falls into the graduate, then adjust the heating so that the distillation proceeds at the rate of 3 ± 1 drops every 2 seconds. At the instant when the bottom of the flask first becomes dry, read the thermometers and simultaneously discontinue the heating so rapidly that material superheating of the vapors is avoided as indicated by the failure of their temperature to rise appreciably above the drypoint reading. Report these readings after making the following corrections:

(a) *Bore correction.*—From a dependable correction certificate furnished preferably by the Bureau of Standards.

(b) *Emergent stem correction.*—Add this correction to each reading: $N(T-t) \times 0.000159$

Where

N =length of exposed mercury column in degrees

T =corrected thermometer reading (as prescribed in (a) and (c)).

t =average temperature of the exposed mercury column.

(c) *Correction for barometric pressure.*—Add 0.047° C. to each reading for every mm. below 760 mm. or subtract for every mm. above 760 mm. Correct the barometric reading, obtained at the tem-

[JAN-T-171]

perature of the barometer for temperature to 0° C., before calculating the barometric pressure correction.

F-5. Retests.—If the composite sample representative of the lot fails to pass the inspection tests, the manufacturer shall have the option of having analysis of each primary sample made at his own expense. The manufacturer may then remove or replace defective portions of the lot which fail to meet the requirements and submit the lot for acceptance, provided that the markings on the container are such that complete removal or replacement of defective portions of the lot can be made to the satisfaction of the inspector.

G. PACKAGING, PACKING, AND MARKING FOR SHIPMENT.

G-1. Packing.—

G-1a. For domestic shipment.—

G-1a(1). Army and Navy.—Unless otherwise specified, toluene shall be furnished in tank cars, or in closed top style 100-gallon or 55-gallon steel drums conforming to the requirements of Interstate Commerce Commission Specification 5B, or in 5-gallon closed top steel containers conforming to the requirements of Interstate Commerce Commission Specification 17E as specified in the contract or order.

G-1a(2). Marine Corps.—Toluene shall be delivered in 1-gallon cans, six cans to a standard commercial shipping container. Cans shall be in accordance with Marine Corps Specification for Cans, One-Gallon; and Cases, Shipping for Packing Shellac, Fire-Extinguishing Liquid, Paint Driers, Varnish, Oils, Disinfectant, etc.

G-1b. For overseas shipment.—Unless otherwise specified, toluene shall be furnished in closed top style 55-gallon steel drums, or 5-gallon closed top steel containers as specified in paragraph G-1a(1), except that the entire exterior shall be protected with a coating conforming to the requirements for type II of U. S. Army Specification 3-181.

G-2. Marking.—

G-2a. One-gallon and five-gallon containers.—Unless otherwise specified, each container shall be plainly marked with the following:

MATERIAL _____
 SPECIFICATION NO. _____
 GRADE _____
 QUANTITY _____
 CONTRACTOR _____
 MANUFACTURER _____
 CONTRACT NO. _____
 GROSS WEIGHT _____
 LOT NUMBER _____

G-2b. Shipping containers.—Unless otherwise specified, each container shall be plainly marked with the following:

MATERIAL _____
 SPECIFICATION NO. _____
 GRADE _____
 QUANTITY _____
 CONTRACTOR _____
 CONTRACT NO. _____
 GROSS WEIGHT _____
 LOT NUMBER _____

In addition, shipments for the Army shall be marked in accordance with U. S. Army Specification 100-2; for the Navy in accordance with

[JAN-T-171]

the requirements of the latest issue of the Navy Shipment Marking Handbook and the Interstate Commerce Commission Regulations for the Transportation of Explosives and other Dangerous Articles by Freight and Express, and for the Marine Corps in accordance with Interstate Commerce Commission Regulations for the Transportation of Explosives and Other Dangerous Articles by Freight and Express.

H. NOTES.

H-1. Requests, requisitions, schedules, and contracts or orders should contain the title of the specification, the number and date.

H-2. Requests, requisitions, schedules, and contracts or orders should specify the grade of toluene desired (see par. B-1) and whether the subject commodity is to be packed and shipments marked for domestic or overseas shipment (see section G.).

H-3. *Uses.*—Grade A toluene is intended for use in the manufacture of trinitrotoluene and dinitrotoluene. Grade B toluene is pure commercial toluene intended for use as a nonsolvent ingredient in nitrocellulose solutions, such as airplane dopes and lacquers, as a paint thinner, and other uses.

H-4. Material should be purchased by volume, the unit being a U. S. gallon at 20° C. (68° F.).

H-5. Purchasers of reagent grade toluene are referred to the requirements contained in the latest revision of the U. S. Pharmacopoeia.

H-6. Copies of the Navy Shipment Marking Handbook may be obtained upon application to the Bureau of Supplies and Accounts, Navy Department, Washington 25, D. C.

H-7. Copies of Joint Army-Navy specifications (required for Army purchases) and U. S. Army specifications may be obtained, as indicated in the "Index of United States Army and Federal Specifications Used by the War Department." Copies of this Index may be obtained from the Superintendent of Documents, Government Printing Office, Washington 25, D. C. Agencies within the War Department will obtain copies of Joint Army-Navy and United States Army specifications through established War Department channels. Both the title and identifying symbol number should be stipulated when requesting copies of specifications.

H-8. Copies of Joint Army-Navy specifications (required for Navy purchases) and Navy Department specifications may be obtained upon application to the Bureau of Supplies and Accounts, Navy Department, Washington 25, D. C., except that Naval activities should make application to the Supply Officer in Command, Naval Supply Depot, Bayonne, N. J. Both the title and identifying symbol number should be stipulated when requesting copies of specifications.

H-9. Copies of Joint Army-Navy specifications (required for Marine Corps purchases) and Marine Corps specifications may be obtained upon application to the Quartermaster General, Headquarters, U. S. Marine Corps, Navy Department, Washington 25, D. C.

Notice.—When Government drawings, specifications, or other data are used for any purpose other than in connection with a definitely related Government procurement operation, the United States Government thereby incurs no responsibility nor any obligation whatsoever; and the fact that the Government may have formulated, furnished, or in any way supplied the said drawings, specifications, or other data is not to be regarded by implication or otherwise as in any manner licensing the holder or any other person or corporation or conveying any rights or permission to manufacture, use, or sell, any patented invention that may be in any way related thereto.

NAVY: 08

[JAN-T-171]

11

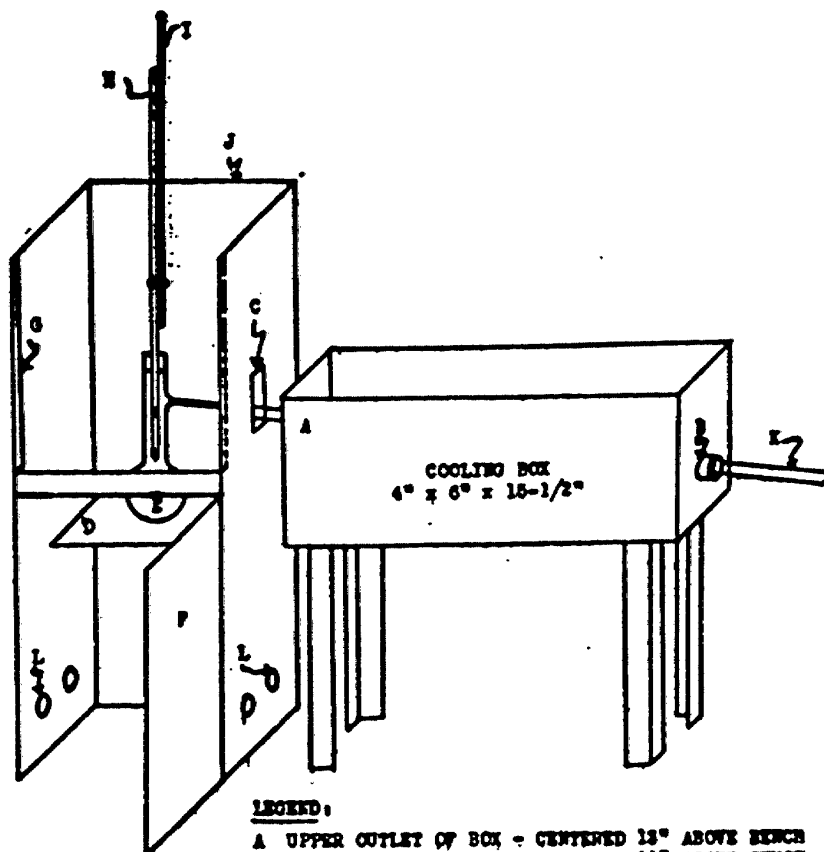
**LEGEND:**

- A** UPPER OUTLET OF BOX - CENTERED 15" ABOVE BENCH
B LOWER OUTLET OF BOX - CENTERED 11" ABOVE BENCH
C 1" x 2-1/2" HOLE - CENTERED 13-3/4" ABOVE BENCH
D 1/4" x 6" x 6" TRANSLITE WITH 1" HOLE IN CENTER
E 200 ML. PYREX DISTILLING FLASK
F GATE, 6" x 11-1/2"
G GUIDES FOR 6" x 6" WIRE GLASS PLATE
H DISTILLATION THERMOMETER
I STEM CORRECTION THERMOMETER
J SHIELD, 6" x 6" x 21"
K 7-9/16" O.D. x 23" CONDENSER TUBE, FLARED
 TO 3/4" O.D. AT ONE END
L 1" HOLES FOR VENTILATION

FIGURE 1.—Apparatus assembly.

[JAN-T-171]

12

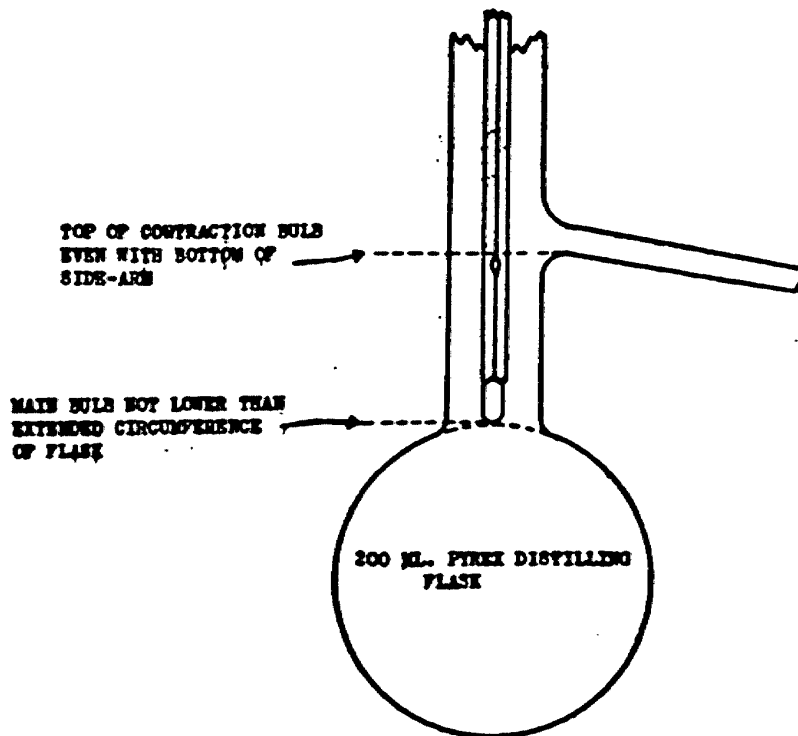

FIGURE 2.—Position of distillation thermometer in flask.

{JAN-T-171}

FOLD

POSTAGE AND FEES PAID



OFFICIAL BUSINESS
PENALTY FOR PRIVATE USE \$300

Commander
Rock Island Arsenal
ATTN: SARRI-LE-S
Rock Island, IL 61201

FOLD