

VV-L-825B
 November 10, 1987
 SUPERSEDING
 VV-L-825A
 24 January 1962
 (See 6 9)

FEDERAL SPECIFICATION

LUBRICATING OIL, REFRIGERANT COMPRESSOR, UNINHIBITED

This specification is approved by the Commissioner, Federal Supply Service, General Services Administration, for the use of all Federal agencies.

1. SCOPE

1.1 Scope. This specification covers lubricating oils for use in refrigerant compressors

1.2 Classification The oil shall be of the following military symbols, as specified (see 6.2)

| | <u>Military symbol</u> | <u>NATO symbol</u> |
|---|------------------------|--------------------|
| Type II - For reciprocating-type refrigerant compressors using refrigerant 12 (for example, dichlorodifluoromethane, methyl chloride, or ammonia) | RCO-2 | 0-282 |
| Type III - For special applications such as two-stage rotary compressors. | RCO-3 | --- |
| Type IV - For use with refrigerant 22 (for example, monochlorodifluoromethane). | RCO-4 | 0-290 |

Beneficial comments (recommendations, additions, deletions) and any pertinent data which may be of use in improving this document should be addressed to Commander, Naval Sea Systems Command, SEA 5523, Department of the Navy, Washington, DC 20362-5101 by using the self-addressed Standardization Document Improvement Proposal (DD Form 1426) appearing at the end of this document or by letter.

AMSC N/A

FSC 9150

DISTRIBUTION STATEMENT A Approved for public release; distribution unlimited

VV-L-825B

2. APPLICABLE DOCUMENTS

2.1 Government publications The issues of the following documents, in effect on date of invitation for bids or solicitation for offers, form a part of this specification to the extent specified herein.

Federal Specification:

PPP-F-320 - Fiberboard, Corrugated and Solid, Sheet Stock (Container Grade), and Cut Shapes

Federal Standards

FED-STD-313 - Material Safety Data Sheets Preparation and the Submission of

FED-STD-791 - Lubricants, Liquid Fuels, and Related Products, Method of Testing.

(Activities outside the Federal Government may obtain copies of Federal standards as outlined under General Information in the Index of Federal Specifications, Standards, and Commercial Item Descriptions. The Index, which includes cumulative bimonthly supplements as issued, is for sale on a subscription basis by the Superintendent of Documents, U S Government Printing Office, Washington, DC 20402.)

(Copies of listed federal and military standards and specifications listed in the Department of Defense Index of Specifications and Standards (DoDISS), should be obtained from the DoD Single Stock Point, Commanding Officer, Naval Publications and Forms Center, 5801 Tabor Avenue, Philadelphia, PA 19120 Copies of industry association documents should be obtained from the sponsor Copies of all other listed documents should be obtained from the contracting activity or as directed by the contracting officer.)

(Federal Government activities may obtain copies of Federal standardization documents and the Index of Federal Specifications, Standards, and Commercial Item Descriptions from established distribution points in their agencies)

Military Specifications.

MIL-G-1149 - Gasket Materials, Synthetic Rubber, 50 and 65 Durometer Hardness.

MIL-R-6855 - Rubber, Synthetic, Sheets, Strips, Molded or Extruded Shapes General Specification for

MIL-L-19140 - Lumber and Plywood, Fire-Retardant Treated

MIL-R-83248 - Rubber, Fluorocarbon Elastomer, High Temperature, Fluid, and Compression Set Resistant.

Military Standards

MIL-STD-105 - Sampling Procedures and Tables for Inspection by Attributes.

MIL-STD-290 - Packaging of Petroleum and Related Products

(Copies of military specifications and standards required by contractors in connection with specific procurement functions should be obtained from the procuring activity or as directed by the contracting officer)

2 2 Other publications The following documents form a part of this specification to the extent specified herein Unless a specific issue is identified, the issue in effect on date of invitation for bids or request for proposal shall apply

AMERICAN SOCIETY FOR TESTING AND MATERIALS (ASTM)

- D 92 - Standard Test Method for Flash and Fire Points by Cleveland Open Cup. (DoD adopted)
- D 97 - Standard Test Method for Pour Point of Petroleum Oils (DoD adopted)
- D 130 - Standard Method for Detection of Copper Corrosion from Petroleum Products by the Copper Strip Tarnish Test (DoD adopted)
- D 189 - Standard Test Method for Conradson Carbon Residue of Petroleum Products. (DoD adopted)
- D 287 - Standard Test Method for API Gravity of Crude Petroleum and Petroleum Products (Hydrometer Method) (DoD adopted)
- D 445 - Standard Test Method for Kinematic Viscosity of Transparent and Opaque Liquids (and the Calculation of Dynamic Viscosity) (DoD adopted)
- D 471 - Standard Test Method for Rubber Property - Effect of Liquids. (DoD adopted)
- D 482 - Standard Test Method for Ash from Petroleum Products (DoD adopted)
- D 611 - Standard Test Methods for Aniline Point and Mixed Aniline Point of Petroleum Products and Hydrocarbon Solvents (DoD adopted)
- D 877 - Standard Test Method for Dielectric Breakdown Voltage of Insulating Liquids Using Disk Electrodes (DoD adopted)
- D 974 - Standard Test Method for Neutralization Number by Color-Indicator Titration (DoD adopted)
- D 1500 - Standard Test Method for ASTM Color of Petroleum Products (ASTM Color Scale). (DoD adopted)
- D 4057 - Standard Practice for Manual Sampling of Petroleum and Petroleum Products (DoD adopted)

(Application for copies should be addressed to the American Society for Testing and Materials, 1916 Race Street, Philadelphia, PA 19103.)

AMERICAN SOCIETY OF HEATING, REFRIGERATING, AND AIR-CONDITIONING ENGINEERS (ASHRAE)

- ASHRAE 86 - Methods of Testing the Floc Point of Refrigeration Grade Oils.
- ASHRAE 97 - Sealed Glass Tube Method to Test the Chemical Stability of Material for Use Within Refrigerant Systems

(Application for copies should be addressed to the American Society of Heating, Refrigerating, and Air-Conditioning Engineers, 1791 Tullie Circle, NE, Atlanta, GA 30329)

VV-L-825B

3 REQUIREMENTS

3.1 Qualification Refrigerant compressor lubricating oils furnished under this specification shall be products which are authorized by the qualifying activity for listing on the applicable qualified products list at the time set for opening of bids (see 4.3 and 6.3).

3.2 Material Refrigerant compressor lubricating oils shall be well-refined petroleum oils, without admixture of fatty acids, fatty oils, resins, soaps, or other objectionable materials

3.3 Toxicity The oil shall have no adverse effect on the health of personnel when used for its intended purpose. The oil shall contain no components which produce noxious vapors in such concentrations as to be an annoyance to personnel during formulation or normal use under conditions of adequate ventilation while exercising caution to avoid prolonged contact with the skin and while observing Occupational Safety and Health Administration (OSHA) guidelines. Questions pertaining to the toxic effects shall be referred by the contracting activity to the Naval Medical Command (NAVMEDCOM), Washington, DC, who will act as a medical advisor to the contracting activity

3.4 Material safety data sheet. The contracting activity shall be provided a material safety data sheet (MSDS) at the time of contract award. The MSDS is form OSHA-20, found in and part of FED-STD-313. The MSDS shall be included with each shipment of the material covered by this specification (see 6.5)

3.5 Physical and chemical requirements Refrigerant compressor lubricating oil shall conform to the requirements specified in table I

TABLE I Physical and chemical requirements

| Property | Type II | Type III | Type IV | Test method |
|---|-----------------------|----------------|-----------------------|-------------|
| Viscosity, cSt, 40 degrees Celsius (°C) | 61.2 - 74.8 | --- | 28.8 - 35.2 | ASTM D 445 |
| Viscosity, cSt 100°C | --- | 21.7 - 26.3 | --- | ASTM D 445 |
| Flash point, degrees Fahrenheit (°F), min | 350 (177°C) | 450 (232°C) | 325 (163°C) | ASTM D 92 |
| Pour point, °F, max | Minus 30 (minus 34°C) | 0 (minus 18°C) | Minus 40 (minus 40°C) | ASTM D 97 |
| Floc point, °F, max | Minus 50 (minus 46°C) | 0 (minus 18°C) | Minus 60 (minus 51°C) | ASHRAE 86 |
| Color | Report | Report | Report | ASTM D 1500 |

TABLE I. Physical and chemical requirements. - Continued

| Property | Type II | Type III | Type IV | Test method |
|---|-----------------------------------|----------|-----------------------------------|----------------------------|
| Total acid no., mg KOH/g, max | 0.05 | 0.05 | 0.05 | ASTM D 974 |
| Dielectric, kV, min | 25 | 20 | 25 | ASTM D 877 |
| Aniline point, °F | 160 - 195 (71 - 90°C) | --- | 160 - 195 (71 - 90°C) | ASTM D 611 |
| Gravity, °API | 21 - 26 | --- | 22 - 27 | ASTM D 287 |
| Chemical stability, percent R-22 | 0.8 - 1.5 | --- | 0.4 - 0.8 | ASHRAE 97 |
| Corrosion | 1 | 1 | 1 | ASTM D 130 |
| Bearing compatibility | Pass | Pass | Pass | Method 3452 1 ² |
| Journal bearing test | ³ 0.9 | Pass | ³ 0.9 | Method 3452 1 ² |
| Carbon residue, percent, max | 0.3 | 1.25 | 0.2 | ASTM D 189 |
| Ash, percent, max | 0.005 | 0.005 | 0.005 | ASTM D 482 |
| Swelling of synthetic rubbers, 10 percent | Plus or minus 5.0 ⁴ | --- | Plus or minus 5.0 ⁴ | ASTM D 471 |

¹ Discoloration of test strip shall be not greater than that caused by oxidation of a blank copper strip when exposed to dry heat oven at 212°F (100°C) for 3 hours.

² FED-STD-791.

³ Journal speed - 3500 revolutions per minute, bearing temperature - 275 ± 1°F (135 ± .55°C).

⁴ Time - 166 hours, temperature - 158°F (70°C).
Rubber specimens MIL-R-6855, class 1, grade 60
MIL-G-1149, type II, class 1
MIL-R-83248

4. QUALITY ASSURANCE PROVISIONS

4.1 Responsibility for inspection. Unless otherwise specified in the contract or purchase order, the contractor is responsible for the performance of all inspection requirements as specified herein. Except as otherwise specified in the contract or purchase order, the contractor may use his own or any other facilities suitable for the performance of the inspection requirements

VV-L-825B

specified herein, unless disapproved by the Government. The Government reserves the right to perform any of the inspections set forth in the specification where such inspections are deemed necessary to assure supplies and services conform to prescribed requirements

4 1 1 Responsibility for compliance. All items must meet all requirements of sections 3 and 5. The inspection set forth in this specification shall become a part of the contractor's overall inspection system or quality program. The absence of any inspection requirements in the specification shall not relieve the contractor of the responsibility of assuring that all products or supplies submitted to the Government for acceptance comply with all requirements of the contract. Sampling in quality conformance does not authorize submission of known defective material, either indicated or actual, nor does it commit the Government to acceptance of defective material.

4 2 Classification of inspections. The inspection requirements specified herein are classified as follows:

- (a) Qualification tests (see 4 3).
- (b) Quality conformance tests (see 4 4).

4 3 Qualification tests. Qualification tests shall be conducted at a laboratory satisfactory to the Naval Sea Systems Command. Qualification tests shall consist of tests for the requirements specified in table I.

4 4 Quality conformance inspection. Quality conformance inspection shall be in accordance with method 9601 of FED-STD-791. Lot determination shall be as specified in 4 4 1. Each sample selected as specified in 4 4 2 shall be subjected to the tests as specified in table I, except the bearing compatibility, chemical stability and journal bearing tests are not required. However, any additional tests deemed necessary by the contracting activity to determine conformance to this specification may be required.

4 4 1 Inspection lot.

4 4.1 1 Bulk lot. A bulk lot shall be an indefinite quantity of a homogeneous mixture of lubricating oil offered for acceptance in a single isolated storage container, or made in a single plant run (not exceeding 24 hours) through the same processing equipment, with no change in the ingredient materials.

4 4 1 2 Packaged lot. A packaged lot shall be an indefinite number of unit containers of identical size and type offered for acceptance, and filled with a homogeneous mixture of lubricating oil from a single isolated container, or filled with a homogeneous mixture of lubricating oil made in a single plant run (not exceeding 24 hours) through the same processing equipment, with no change in the ingredient materials.

4 4 1 3 Delivery lot. For the purpose of sampling, a delivery lot shall be all lubricating oil in a single shipment.

4.4.2 Sampling

4.4.2.1 Sampling a storage tank. Unless otherwise specified (see 6.2), a representative sample of 5 gallons of lubricating oil shall be taken from each lot in accordance with ASTM D 4057.

4.4.2.2 Sampling during plant run. A representative sample of lubricating oil shall be drawn at the discharge pipe where it enters the receiving vessel or vessels. At least four samples shall be taken at regular intervals during the entire period of loading or filling with each sample being 1 pint.

4.4.2.3 Sampling of filled containers Where the lubricating oil is contained in 1-quart and 1-gallon cans, samples shall be drawn from the containers as specified in ASTM D 4057. When the lot contains less than five containers, each container shall be sampled.

4.4.3 Rejection of lots. When the sample of lubricating oil fails any of the tests, this shall be cause for rejection of the lot represented by the sample.

4.5 Examination of filled containers. A random sample of filled containers shall be selected from each lot in accordance with MIL-STD-105 at inspection level I. The Acceptable Quality Level (AQL) shall be 2.5 percent defective to verify compliance with this specification regarding fill, closure, marking, and other requirements not involving tests. Samples shall be examined for defects of the container and the closure, for evidence of leakage, and for unsatisfactory markings. Each sample filled container shall also be weighed to determine the amount of the contents. Any container in the sample having one or more defects or under required fill shall be cause for rejection of the container. If the number of defective containers in any sample exceeds the acceptance number for the appropriate sampling plan of MIL-STD-105, this shall be cause for rejection of the lot represented by the sample.

4.6 Toxicity To determine conformance to requirements of 3.3, the manufacturer of the material shall disclose the formulation of his product to the Naval Medical Command, MEDCOM-242, Washington, DC 20372. The disclosure of proprietary information, which shall be held in confidence by the Naval Medical Command, shall include: the name, formula, and approximate percentage by weight and volume of each ingredient in the product; the results of any toxicological testing of the product; identification of its pyrolysis products; and any such other information as may be needed to permit an accurate appraisal of any toxicity problem associated with the handling, storage, application, use, disposal, or combustion of the material. Information submitted shall be clearly marked or identified to show it is being provided in connection with qualification under VV-L-825.

5. PACKAGING

(The packaging requirements specified herein apply only for direct Government acquisition.)

5.1 Packaging, packing, and marking The lubricating oil in the quantity and container specified (see 6.2), shall be packaged and packed level B, C, or commercial as specified (see 6.2), and marked in accordance with MIL-STD-290

VV-L-825B

Acquisition options shall be in accordance with the ordering data of MIL-STD-290 as applicable. In addition, for Navy acquisitions, the following Navy fire-retardant requirements shall apply.

- (a) Lumber and plywood When specified (see 6.2), all lumber and plywood including laminated veneer material used in shipping container and pallet construction, members, blocking, bracing, and reinforcing shall be fire-retardant treated material conforming to MIL-L-19140 as follows

Level B - Type II - weather resistant
 Category I - general use
 Level C - Type I - non-weather resistant
 Category I - general use.

- (b) Fiberboard When specified (see 6.2), fiberboard used in the construction of class-domestic, non-weather resistant fiberboard, and cleated fiberboard boxes shall meet the flame spread index and specific optic density requirements of PPP-F-320 and amendments thereto

6 NOTES

6.1 Intended use The lubricating oils covered by this specification are intended for the lubrication of the compression unit of refrigeration equipment operated on refrigerant 12 (for example, dichlorodifluoromethane), refrigerant 22 (for example, monochlorodifluoromethane), methyl chloride or ammonia

6.2 Ordering data Acquisition documents should specify the following:

- (a) Title, number, and date of this specification
 (b) Symbol required (see 1.2).
 (c) When representative sample of lubricating oil is different than specified (see 4.4.2.1).
 (d) Type and size of the container required (see 5.1).
 (e) Level of packaging and packing required (see 5.1).
 (f) When fire-retardant materials are required (see 5.1(a) and (b)).
 (g) Quantity in gallons. The material should be purchased by volume, the unit being a U.S. gallon, at 60°F (15.6°C)

6.3 Qualification With respect to products requiring qualification, awards will be made only for products which are, at the time set for opening of bids, qualified for inclusion in the applicable qualified products list whether or not such products have actually been so listed by that date. The attention of the supplier is called to this requirement, and manufacturers are urged to arrange to have the products they propose to offer to the Federal Government tested for qualification in order that they may be eligible to be awarded contracts or orders for the products covered by this specification. The activity responsible for the qualified products list is the Naval Sea Systems Command, SEA 5523, Department of the Navy, Washington, DC 20362-5101, and information pertaining to qualification of products may be obtained from that activity.

6.4 The index of test methods in FED-STD-791 lists the corresponding equivalent test methods of ASTM.

6 5 Material safety data sheets. Contracting officers will identify those activities requiring copies of completed Material Safety Data Sheets (MSDS) prepared in accordance with FED-STD-313. The pertinent Government mailing addresses for submission of data are listed in appendix B of FED-STD-313. In order to obtain the MSDS, federal acquisition regulation FAR clause 52 223-3 must be in the contract.

6 6 Subject term (key word) listing.

Ammonia
 Dichlorodifluoromethane
 Lubricating oil
 Methyl chloride
 Monochlorodifluoromethane
 Reciprocating refrigerant compressors
 Refrigerant compressors
 Viscosity

6.7 International standardization agreements Certain provisions of this specification are the subject of international standardization agreement NATO-STANAG-1135. When amendment, revision, or cancellation of this specification is proposed which affects or violates the international agreement concerned, the preparing activity will inform GSA so that appropriate reconciliation action may be taken through international standardization channels.

6 8 Supersession data Type IV lubricating oil can be used in place of type I oil. Type I oil was listed in revision A of VV-L-825.

6 9 Changes from previous issue. Asterisks are not used in this revision to identify changes with respect to the previous issue due to the extensiveness of the changes.

MILITARY INTERESTS

Custodians

Army - MR
 Navy - SH
 Air Force - 68

Review activities

Army - MI
 DLA - GS

User activity:

Navy - YD

CIVIL AGENCY COORDINATING ACTIVITIES
 GSA-FSS

Preparing activity:
 Navy - SH
 (Project 9150-1001)

APPENDIX

EQUIPMENT AND PROCEDURES
FOR MEASURING THE R-22 CONTENT
IN SEALED TUBES USING GAS CHROMATOGRAPHY

10. SCOPE

10.1 Scope. This appendix covers the equipment and procedures used for measuring the content of R-22 refrigerant in gases evolved during the sealed tube stability testing of refrigerant oils in accordance with ASHRAE 97.

10.2 Summary. The procedure consists of isolating the gas evolved during aging of the sealed tube, then analyzing it using gas chromatography. Concentrations of R-22 and R-12 refrigerants in the evolved gas shall then be obtained by integration of the gas chromatogram peaks.

20. APPLICABLE DOCUMENTS

20.1 Government publications. The issues of the following documents, in effect on date of invitation for bids or solicitation for offers, form a part of this specification to the extent specified herein.

SPECIFICATIONS

FEDERAL

- BB-H-1168 - Helium, Technical
- BB-N-411 - Nitrogen, Technical.

30. APPARATUS

30.1 Sealed glass tube. A sealed glass tube containing R-12, refrigeration oil, and strips of copper and steel shall be used in accordance with ASHRAE 97.

30.2 Tube opening apparatus. The tube-opening apparatus shown in ASHRAE 97, shall be used.

30.3 Gas handling system. A gas handling system equipped with a vacuum pump, a sample port to gas chromatograph, and a manometer shall be used. A diagram of this system is shown on figure 1.

30.4 Gas chromatograph. A gas chromatograph equipped with a thermal conductivity detector and a sampling valve shall be used and shall operate as follows

- (a) Column temperature: 75°C
- (b) Injector temperature: ambient
- (c) Detector temperature: 125°C
- (d) Helium flow rate: 60 milliliters/minute
- (e) Sample size: 5 mL
- (f) Recorder span: 1 millivolt
- (g) Chart speed: 1 inch per minute
- (h) Filament current: 200 milliamperes at 15 volts

VV-L-825B
APPENDIX

30 5 Column Ten feet by 1/4 inch Parapak Q, 50-80 mesh, with a 2 inch 50-80 mesh drierite water scrubber at the head of the column

40 REAGENTS AND MATERIALS

40 1 Helium Helium shall conform to the requirements of BB-H-1168, type I, grade A

40 2 Liquid nitrogen Liquid nitrogen shall conform to the requirements of BB-N-411, type II

40 3 TFE tape

50 PROCEDURE

50 1 A sealed tube shall be stored for 14 days in a 175°C environment. After that period, the tube shall be removed and the lower half shall be submerged in a Dewar flask containing liquid nitrogen until the sample is completely frozen. The tube shall then be removed and a small file scratch shall be made near the tip. The sample shall then be refrozen.

NOTE After the tube is frozen, the refrigerant pressure is no longer present. However, if noncondensable gases (such as carbon monoxide and hydrogen) were developed by reactions during the aging period, then considerable pressure may still be present in the tube. Also, the tube may have been weakened by the attack of fluorine-containing acids which may have formed during the aging period. If proper care is not used in handling the sample tube, then a serious accident will occur. Therefore, all safety procedures specified in ASHRAE 97 shall be followed.

50 2 The sealed tube shall be placed in the tube-opening apparatus and connected to the gas handling system, leaving the connecting valve open. Each valve in the gas handling system, except the vacuum pump valve, shall be closed. Then the system shall be evacuated to the limit of the vacuum pump (approximately 1 millimeter mercury). The pump shall be isolated from the rest of the system.

50 3 The valve on the tube-opening apparatus shall be closed. Then the tip of the sealed tube shall be broken off by a sideways motion of the tube. The sample tube shall then be submerged in a beaker of hot water to thaw the contents.

50.4 The valve on the tube-opening apparatus shall be opened slowly to allow approximately 1 atmosphere of gas to escape into the gas handling system. The valve shall then be closed. The gas sample valve shall then be opened, and a 5 mL gas sample shall be injected into the gas chromatograph.

50 5 Using an electronic integrator or planimeter, the peak areas for R-22 and R-12 refrigerants shall be determined on the gas chromatogram. (Other peaks on the chromatogram should be ignored.)

60. CALCULATIONS

60.1 The percent of R-22 in the gas sample shall be calculated using the following formula:

$$\text{R-22, volume percent} = \left(\frac{\text{AR-22}}{\text{AR-12} + \text{AR-22}} \right) \times 100$$

Where:

AR-22 = R-22 peak area

AR-12 = R-12 peak area

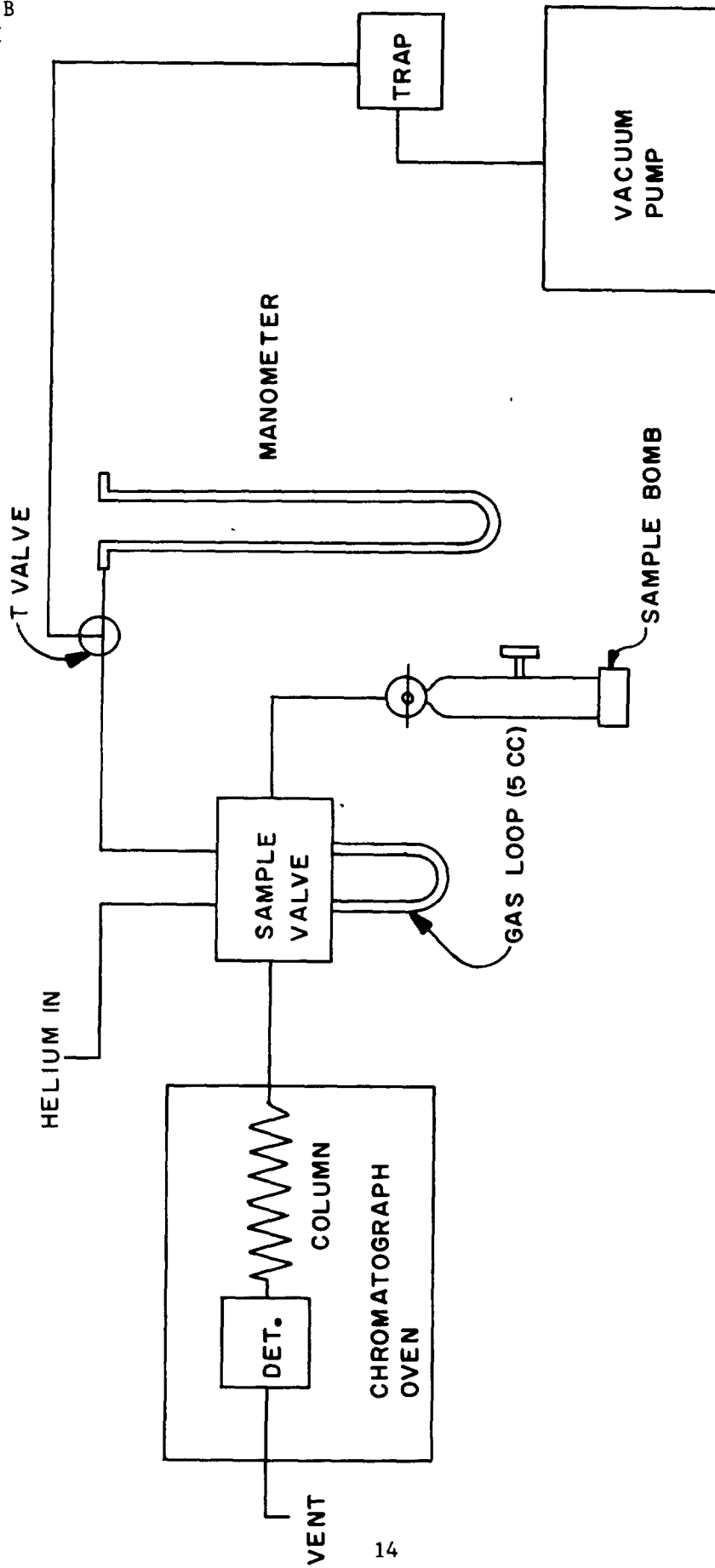

NOTE: NOT TO SCALE

FIGURE 1. Gas handling system.

SH 13203050

INSTRUCTIONS: In a continuing effort to make our standardization documents better, the DoD provides this form for use in submitting comments and suggestions for improvements. All users of military standardization documents are invited to provide suggestions. This form may be detached, folded along the lines indicated, taped along the loose edge (*DO NOT STAPLE*), and mailed. In block 5, be as specific as possible about particular problem areas such as wording which required interpretation, was too rigid, restrictive, loose, ambiguous, or was incompatible, and give proposed wording changes which would alleviate the problems. Enter in block 6 any remarks not related to a specific paragraph of the document. If block 7 is filled out, an acknowledgement will be mailed to you within 30 days to let you know that your comments were received and are being considered.

NOTE This form may not be used to request copies of documents, nor to request waivers, deviations, or clarification of specification requirements on current contracts. Comments submitted on this form do not constitute or imply authorization to waive any portion of the referenced document(s) or to amend contractual requirements.

(Fold along this line)

(Fold along this line)

DEPARTMENT OF THE NAVY

COMMANDER
NAVAL SEA SYSTEMS COMMAND (SEA 5523)
DEPARTMENT OF THE NAVY
WASHINGTON, DC 20362-5101



NO POSTAGE
NECESSARY
IF MAILED
IN THE
UNITED STATES

OFFICIAL BUSINESS
PENALTY FOR PRIVATE USE \$300

BUSINESS REPLY MAIL
FIRST CLASS PERMIT NO 12503 WASHINGTON D C

POSTAGE WILL BE PAID BY THE DEPARTMENT OF THE NAVY

COMMANDER
NAVAL SEA SYSTEMS COMMAND (SEA 5523)
DEPARTMENT OF THE NAVY
WASHINGTON, DC 20362-5101

