

TT-S-001543A(CON-NBS)  
June 9, 1971  
SUPERSEDING  
Int. Fed. Spec. TT-S-001543 (CON-NBS)  
November 27, 1968

## INTERIM FEDERAL SPECIFICATION

### SEALING COMPOUND: SILICONE RUBBER BASE (FOR CALKING, SEALING, AND GLAZING IN BUILDINGS AND OTHER STRUCTURES)

This Interim Federal Specification was developed by the National Bureau of Standards, Washington, D.C. 20234, based upon currently available technical information. It is recommended that Federal agencies use it in procurement and forward recommendations for changes to the preparing activity at the address shown above.

#### 1. SCOPE AND CLASSIFICATION

1.1 Scope. This specification covers the properties of a single component cold-applied silicone rubber base joint sealing compound (joint sealant) for sealing, calking, and glazing operations in buildings, building areas, and other types of construction.

1.2 Classification. The sealing compound covered by this specification shall be of one type and two classes as follows, as specified (see 6.2):

Type - Non-sag.

Class A - Compounds resistant to 50 percent maximum total joint movement [1], [2]

Class B - Compounds resistant to 25 percent maximum total joint movement [1], [2]

#### 2. APPLICABLE DOCUMENTS

2.1 The following documents of the issues in effect on the date of invitation for bids or request for proposal, form a part of this specification to the extent specified herein:

##### Federal Specifications:

- SS-R-406 - Road and Paying Materials; Methods of Sampling and Testing.
- PPP-B-585 - Boxes, Wood, Wirebound.
- PPP-B-601 - Boxes, Wood, Cleated-Plywood.
- PPP-B-621 - Boxes, Wood, Nailed and Lock-Corner.
- PPP-B-636 - Box, Fiberboard.
- PPP-B-640 - Boxes, Fiberboard, Corrugated, Triple-Wall.
- PPP-C-96 - Cans, Metal, 28 Gage and Lighter.
- PPP-B-320 - Fiberboard, Corrugated and Solid, Sheet Stock (Container Grade), and Cut Shapes.
- PPP-P-704 - Pails, Metal: Shipping, Steel, (1 through 12 Gallon).

[1] To clarify the meaning of 50 percent maximum total joint movement, the following hypothetical examples are given: If a building joint is filled on the hottest day of the year the maximum seasonal movement of 50 percent will occur in extension only and none in compression, beyond the original nominal joint width. Likewise if a joint is filled on the coldest day of the year, the maximum seasonal movement of 50 percent will occur in compression only and none in extension, i.e., beyond the original nominal

joint width. At all other times of sealant installation there will be a combination of extension and compression beyond the nominal width of the joint. The combinations might be 5 percent in extension and 45 percent in compression; 25 percent in extension and 25 percent in compression; 35 percent in extension and 15 percent in compression; or any other such combination of extension and compression totaling a maximum of 50 percent. For Class B sealants the same explanation as given above applies except that the anticipated maximum total movement is 25 percent.

- [2] The sealant covered by this specification shall not be used in sealing joints in horizontal decks, plazas, patios, driveways, terraces and other areas where foot traffic and mechanical abuse are encountered. The sealant shall not be used in submerged joints such as in fountains, reflecting, and swimming pools.

FSC 8030

TT-S-001543A(COM-NBS)

Federal Standards:

- Fed. Std. No. 123 - Marking for Domestic Shipment (Civilian agencies).
- Fed. Test Method Std. No. 141 - Paint, Varnish, Lacquer and Related Materials; Methods of Inspection, Sampling, and Testing.
- Fed. Test Method Std. No. 601 - Rubber: Sampling and Testing.

(Activities outside the Federal Government may obtain copies of Federal Specifications, Standards, and Handbooks as outlined under General Information in the Index of Federal Specifications and Standards and at the prices indicated in the Index. The Index, which includes cumulative monthly supplements as issued, is for sale on a subscription basis by the Superintendent of Documents, U. S. Government Printing Office, Washington, D.C. 20402.)

(Single copies of this specification and other Federal Specifications required by activities outside the Federal Government for bidding purposes are available without charge from Business Service Centers at the General Services Administration Regional Offices in Boston, New York, Washington, D.C., Atlanta, Chicago, Kansas City, Mo., Fort Worth, Denver, San Francisco, Los Angeles, and Seattle, Washington.)

(Federal Government activities may obtain copies of Federal Specifications, Standards, and Handbooks and the Index of Federal Specifications and Standards from established distribution points in their agencies.)

Military Standards:

- MIL-STD-105 - Sampling Procedures and Tables for Inspection by Attributes.
- MIL-STD-129 - Marking for Shipment and Storage.

(Copies of Military Specifications and Standards required by contractors in connection with specification procurement functions should be obtained from the procuring activity or as directed by the contracting officer.)

2.2 Other publications. The following documents form a part of this specification to the extent specified herein. Unless a specific issue is identified, the issue in effect on date of invitation for bids or request for proposal shall apply.

American Society for Testing and Materials (ASTM) Standards:

- C33 - Specifications for Concrete Aggregates.
- C150 - Specifications for Portland Cement.
- C510 - Method of Test for Staining and Color Change of One - or Two-Part Joint Sealants.
- D1191 - Methods of Testing Concrete Joint Sealers.
- D2240 - Test for Indentation Hardness of Rubber and Plastics by Means of a Durometer.

(Application for copies should be addressed to the American Society for Testing and Materials, 1916 Race Street, Philadelphia, PA 19103.)

National Motor Freight Traffic Association, Incorporated, Agent:

National Motor Freight Classification.

(Application for copies shall be addressed to the National Motor Freight Traffic Association, Inc., Agent, 1616 P Street N.W., Washington, D.C. 20036.)

Uniform Classification Committee, Agent:

Uniform Freight Classification.

(Application for copies should be addressed to the Uniform Classification Committee, Tariff Publishing Officer, Room 202 Union Station, 516 W. Jackson Blvd., Chicago, IL 60606.)

### 3. REQUIREMENTS

3.1 Material. The sealing compound shall be furnished as a single component material packaged in sealed cartridges (plastic, metal, or cardboard) or in larger containers (metal cans, pails, or drums). The compound shall be a

TT-S-001543A(COM-NBS)

homogenous mixture of a proper consistency suitable for immediate application by hand or pressure caulking gun, or by hand tool. The compound when completely cured shall form an elastomeric-type solid capable of maintaining a seal against water, wind, and dirt.

3.2 Types and classes. The sealant shall be available in one type and two classes as follows:

Type - Non-sag shall be a compound which permits application in joints on vertical surfaces without sagging (slumping) at temperatures between -20 deg. and +122 deg. F. (-29 deg. and 50 deg. C.).

Class A - Compounds capable of resisting compression-extension cycling of plus or minus 25 percent of the nominal half inch width, as specified in the durability requirement (see 4.3.9.4.1).

Class B - Compounds capable of resisting compression-extension cycling of plus or minus 12-1/2 percent of the nominal half inch joint width as specified in the durability requirement (see 4.3.9.4.2).

3.3 Stability. The compound in the original unopened container shall be stable for at least six months when stored at a temperature not exceeding 80 deg. F. (26.7 deg. C.).

3.4 Toxicity. The material shall have no adverse effects on the health of personnel when used for its intended purpose. Manufacturer's instructions and precautions for use shall be followed explicitly.

3.5 Detail requirements.

3.5.1 Color. The color of the sealant, after curing 14 days in air at standard conditions of temperature and relative humidity (see 4.3.1) shall be any specific color agreed upon by the purchaser and supplier (see 6.2).

3.5.2 Rheological properties. The flow of the compound shall be such that when tested as prescribed 4.3.2.1 it shall not sag or flow more than 3/16 inch in vertical displacement. The compound shall show no deformation when tested as prescribed in 4.3.2.2.

3.5.3 Extrusion rate. The compound shall have an extrusion rate of not more than 45 seconds when tested as prescribed in 4.3.3.

3.5.4 Hardness property at standard conditions. The compound after 21 days cure shall show a hardness reading of not less than 15 nor more than 50 when tested with a Durometer, model A2, instantaneous method, as prescribed in 4.3.4.

3.5.5 Weight loss, cracking, and chalking after heat aging. The compound shall not lose more than 10 percent of its original weight, nor shall it show any cracks or chalking after heat treatment at 158 deg.  $\pm$  3.6 deg. F. (70 deg.  $\pm$  2 deg. C.) when treated as prescribed in 4.3.5.

3.5.6 Tack-free time. The compound shall cure to a tack-free condition in not more than 72 hours, when tested as prescribed in 4.3.6.

3.5.7 Stain and color change. The compound shall not cause any visible stain on the top surface of a white cement mortar base when tested as prescribed in 4.3.7. The compound itself shall not show a degree of color change that is unacceptable to the purchaser, when tested as prescribed in 4.3.7. Back-up material to be used with the sealant shall not cause any

discoloration or staining of the sealant when tested as prescribed in 4.3.8.

3.5.8 Durability. When tested as prescribed in 4.3.9 with standard mortar, glass and aluminum, or any other specified substrate, the total loss in bond area and cohesion area and/or equivalent amount of sealant deformation among the 3 specimens tested shall be no more than 1-1/2 square inches. See 4.3.9.4.1.1 regarding the presence of bubbles in the sealant.

3.5.9 Adhesion-in-peel. When tested as prescribed in 4.3.10 with standard mortar, glass and aluminum, or any other specified substrate the peel strength for each individual test shall not be less than 5 pounds. In addition the compound shall show no more than 25 percent adhesion loss for each individual test.

TT-S-001543A(CON-NBS)

3.6 Adhesion-in-peel after ultraviolet radiation through glass. When tested as prescribed in 4.4 the requirements shall be the same as specified in 3.5.9.

#### 4. QUALITY ASSURANCE PROVISIONS

4.1 Responsibility for inspection. Unless otherwise specified in the contract or purchase order, tire supplier is responsible for the performance of all inspection requirements specified herein. Except as otherwise specified the supplier may utilize his own facilities or any commercial laboratory acceptable to the Government. The Government reserves the right to perform any of the inspections set forth in the specification where such inspections are deemed necessary to assure that supplies and services conform to the prescribed requirements.

4.2 Sampling and inspection shall be in accordance with methods 1011, 1021, and/or 1031 of Fed. Test Method Std. No. 141, as applicable.

4.2.1 Inspection of preparation for delivery. An inspection shall be made to determine that the packaging, packing, and marking comply with the requirements in section 5. Defects shall be scored in accordance with table I. For examination of interior packaging, the sample unit shall be one shipping container fully prepared for delivery selected at random just prior to the closing operations. Sampling shall be in accordance with MIL-STD-105. Defects of closure listed shall be examined on shipping containers fully prepared for delivery. The lot size shall be the number of shipping containers in the end item inspection lot. The inspection level shall be S-2 with an AQL of 4.0 defects per hundred units.

TABLE I. Classification of preparation for delivery defects

Examine	Defects
Marking (Exterior and Interior)	Omitted; incorrect; illegible; improper size, location, sequence, or method of application.
Materials	Any component missing or damaged.
Workmanship	Inadequate application of component such as incomplete closure of container flaps, loose strapping, inadequate stapling, or distortion of container.

#### 4.3 Laboratory tests.

4.3.1 Standard conditions for laboratory tests. The standard conditions of temperature and relative humidity referred to in the following sections are defined as 73.4 deg. +/- 3.6 deg. F. (23 deg. +/- 2 deg. C.) and 50 +/- 5 percent, respectively. The sealant sample shall be held in the unopened container for at least 24 hours at standard conditions before the laboratory tests are started.

#### 4.3.2 Rheological properties.

4.3.2.1 Vertical slump . Apparatus and accessory materials required are: (1) oven, convection type controlled at 121 deg.F. +/- 3.6 deg. F. (50 deg. +/- 2 deg. C.); (2) cold box, controlled at 40 deg. +/- 3 deg. F. (40 deg. +/- 1.7 deg. C.); (3) two stainless steel channels (type 304, 2-B finish, approximately No. 16 gage) with inside dimensions 3/4 inch wide, 1/2 inch deep, and 6 inches long with the top end open and the back surface extended 2 inches (Figure 1b). Clean the channel with methyl ethyl ketone or similar

solvent followed by a thorough cleaning with a detergent solution and a final rinse with distilled or deionized water and then allow to air dry.[3] Before preparing the test assemblies expose the two channels for 2 hours, one in the cold box and one in the oven. At the end of the conditioning period remove the channels from the respective chambers and fill with the compound within 10 minutes. Return the filled channels to the chambers and set in a vertical position with the 2 inch extension in the base position. At the end of 4 hours remove the channels from the chambers and measure the sag of the compound at the lower ends to the nearest 1/16 inch.

4.3.2.2 Horizontal slump. Repeat the procedure described in 4.3.2.1 with the following change: after filling the 2 channels return them to their respective chambers and set them in a horizontal position with the channels lying on the 1/2 inch side. At the end of the exposure period remove channels from the channels and record any change in configuration of the compound in the channels.

[3] Methyl ethyl ketone and similar solvents are both toxic and flammable and should be handled with caution in a well-ventilated hood.



TT-S-001543A (COM-NBS)

4.3.3 Extrusion rate. Apparatus and accessory materials required are: (1) cold box maintained at -15 deg. +/- 3 deg. F. (-26.1 deg. +/- 1.7 deg. C.); (2) 6 ounce capacity air powered calking gun ("Semco", "Pyles", or similar types); (3) standard 6 ounce polyethylene cartridge and plunger with front opening of 0.540 +/- 0.002 inch, inside diameter; (4) 50 p.s.i. air supply; (5) pint container; (6) timer with second hand. Place a sufficient amount of the compound into the cartridge to completely fill it, with plunger in place. Place the filled cartridge, vertically in the cold box for 3 hours. At the end of 3 hours, with no nozzle added to the cartridge, gun the compound at 50 p.s.i. pressure into the empty pint container. Determine the time, in seconds, it takes to empty the cartridge. (Figure 2).

#### 4.3.4 Hardness property.

4.3.4.1 Preparation of specimens. Accessory materials required are: (1) Durometer, Model A2, described in Federal Test Method Std. No. 601, method 3021 or ASTM Standard D2240; (2) brass frame with inside dimensions 5 by 1-1/2 by 1/4 inch thick; (3) two aluminum plates, 6 by 3 inches; (4) thin knife blade; (5) metal straight edge. Take all readings by the instantaneous method using a total load on the indenter of 1300 grams (2.8 lbs.). To obtain precise readings it is recommended that a stand be used, fitted with a Durometer to which an 822 gram weight is attached. This results in an approximate total force of 1300 grams on the indenter. (See Figure 3a). Center the frame on the aluminum plate and fill the opening with a portion of the sample striking off the compound flat with a straight edge. Lift up the frame from sealant after running the thin knife blade along the inside edge of the frame. Prepare 2 specimens. (Figure 3b - A, B).

4.3.4.2 Curing of hardness specimens. Cure the test specimens at standard conditions for 21 days.

4.3.4.3 Hardness measurements. At the end of 21 days curing period take 3 hardness readings on each specimen at standard conditions. Take the readings no closer than 1/2 inch from the edges of the sealant pat and also no closer than 1 inch from each other. The average of 6 readings is the accepted value.

4.3.5 Weight loss, cracking, and chalking after heat aging. Apparatus and materials required are, (1) forced draft oven controlled at 158 deg. +/- 3.6 deg. F. (70 deg. +/- 2 deg. C.); (2) balance sensitive to 0.01g.; (3) materials listed in 4.3.4.1. After weighing two aluminum plates to the nearest 0.01g, two specimens shall be prepared as described in 4.3.4.1 and weighed to the nearest 0.01g. The specimens shall be exposed for 7 days at standard conditions. Following this exposure period they shall be placed in an oven controlled at 158 deg. +/- 3.6 deg. F. (70 deg. +/- 2 deg. C.) for an additional 21 days. At the end of the heat treatment the specimens shall be allowed to cool for 1 hour at standard conditions and weighed to the nearest 0.01g. The percentage weight loss of the compound (based on the original net weight of the compound) shall be calculated for each specimen. The average weight loss in percent obtained from the two specimens shall be the accepted value. The compound shall be examined for cracks and chalking.

4.3.6 Tack-free time. Accessory materials required are, (1) brass weight 30g. 1-5/8 by 1 by 1/8 inch; (2) two clear low density polyethylene strips, 4 by 1 by 0.006 inches thick; (3) materials listed in 4.3.4.1. Prepare two specimens as described in 4.3.4.1. After the specimens have been exposed for 72 hours at standard conditions center the plastic strip length-wise along the top surface of the compound. Set the brass weight in the center on top of the polyethylene strip and allow it to remain for 30 seconds. Remove the brass weight and then slowly withdraw the polyethylene strip pulling it with thumb and forefinger at 90 degrees to the compound at a constant rate over a

period of 15 seconds (Figure 4).

4.3.7 Stain and color change. Test shall be performed in accordance with ASTM Standard C-510. Figure 5 illustrates the steps in the preparation of the stain test specimens.

4.3.8 Stain and discoloration effects of back-up material on sealing compound. Apparatus and materials required are: (1) accelerated weathering machine as specified in ASTM Standard C-510, (2) three specimens prepared on aluminum plates (no mortar) as described in 4.3.4.1. Immediately after preparing the specimens press a 5 inch strip of the back-up material lengthwise into the center of the sealant of one of the specimens. Using a small spatula, cover completely any exposed back-up material with a thin layer of additional sealant. Allow the three specimens to cure for 7 days at standard conditions. At the end of the curing period place the specimen with the backup material and one specimen without back-up material in the weathering machine for 100 hours (ASTM Standard C-510). Leave third specimen at standard conditions. Remove specimens from weathering machine after the specified time and examine them for stain and discoloration and record results.

TT-S-001543A(COM-NBS)

#### 4.3.9 Durability (bond-cohesion).

4.3.9.1 Apparatus required: (1) extension-compression machine; (2) cold box or chamber maintained at -15 deg. +/- 3 deg. F. (-26.1 deg. +/- 1.7 deg. C.); (3) forced draft oven controlled at 158 deg. +/-3.6 deg. F. (70 deg. +/- 2 deg. C.). The machine used in this test shall be so designed that the test specimen can be automatically compressed and extended at a constant rate of 1/8 inch per hour. For Class A sealants, the compression shall be 25 percent of the nominal 112 inch width to 3/8 inch and the extension to 5/8 inch. For Class B the compression shall be 12-1/2 percent, to 7/16 inch and the extension to 9/16 inch. The machine may be similar to the one shown in figure 6a, 6b, or the one described in SS-R-406 method 223-12, or in ASTM Standard 1191, as shown in figure 6c. The machines shall be equipped with grips of sufficient thickness to resist elastomeric sealants with high tensile strength.

4.3.9.2 Accessory materials. The standard accessory blocks and plates (substrates) used in the test are: (1) Portland cement mortar; (2) plate glass; (3) aluminum alloy [4].

4.3.9.2.1 Mortar blocks. Mortar block, 3 by 1 by 1 inch shall be prepared as described in ASTM D1191. The cement shall conform to type III of the specifications for Portland Cement (ASTM C150). The sand (fine aggregate) shall conform to the requirements of specifications for Concrete Aggregates (ASTM C33, Fine Aggregates). The exceptions to the requirements in ASTM D1191 are: (1) the blocks shall be 3 by 1 by 1 inches; (2) the blocks shall be surfaced by wet grinding on an iron lap with No. 60 silicon carbide or aluminum oxide.

4.3.9.2.2 Plate glass. Glass accessory plates shall be 3 by 1 by 1/4 inches water white polished plate glass. Prior to use the glass shall be cleaned as specified in 4.3.2.1 for steel channels.[5]

4.3.9.2.3 Aluminum. The aluminum plates shall be 3 by 1 by 1/4 inches aluminum alloy, 6063-T5 or 6061-T6 clear anodized a minimum of 20 minutes over a scale free finish. Prior to use, the aluminum shall be cleaned as specified for the steel channel in 4.3.2.1.[6]

4.3.9.3 Preparation of test specimens. Prepare three test specimens for each accessory material that is used with the sample under test. After maintaining the unopened sample at standard conditions for at least 24 hours apply a bead of sealant, 2 inches long, 112 inch wide and 3/8 inch deep between parallel 3 by 1 inch faces of 2 similar accessory blocks or plates as shown in figures 7a, 7b, and 7c. Wood or metal spacer bars are used to form the proper size of bead. Polyethylene tape, paraffin, or any other suitable mold release agent is applied to the inside surfaces of the spacers to prevent adhesion of the spacers to the sealant, after cure. Adhesive tape, rubber bands, or clamps are used to hold the test assembly together before and after filling with the compound.[7]

4.3.9.3.1 Primers. Substrate materials shall be primed with the manufacturer's recommended primer only when such primer is specified by the seller and agreed upon by the purchaser. Use of such primers, including manufacturer's designation, shall be included in the test report. When a primer shows staining or discoloration of the substrate beyond the primed area, such effects shall also be noted in the report.

#### 4.3.9.4 Cycling procedure.

4.3.9.4.1 Class A sealants. Cure the test assemblies for 21 days as specified in 4.3.4.2. At various times during the curing period attempts should

be made to separate the spacers from the sealant to help promote the cure. Following the 21 day curing period remove the spacers and proceed as follows:

- [4] Other substrates such as brick, cast stone, marble, stainless steel, etc. may be specified either in place of the standard materials, or in addition to them at the request of the purchaser.
- [5] At the request of the sealant manufacturer the detergent cleaning step shall be omitted from the specified cleaning procedure.
- [6] All non-porous substrate materials shall be cleaned as specified for the steel channel in 4.3.2.1, except as indicated in [5]. Porous accessory blocks, other than standard mortar shall be dried-and cleaned as specified in 4.3.9.2.1.
- [7] If manufacturer's directions for use of the sample indicate that the compound shall not be used in joints with porous substrates do not include standard mortar or an), other porous substrate such as brick, limestone, marble, etc. in the test.

TT-S-001543A(COM-NBS)

1. Immerse the specimens in distilled or deionized water for 7 days.
2. Following the immersion period, remove specimens from water and hand-flex twice about 60 degrees to check bond and cohesion. If no failure occurs, compress the specimens 25 percent of the nominal half inch to 3/8 inch using a "C" clamp and 3/8 inch spacer blocks to hold specimens in place. Place compressed specimens in the draft oven for 7 days (Figure 7d).
3. After the oven treatment, allow the specimens to cool to standard temperature and place them in a machine which automatically compresses the joints from the nominal 1/2 inch width to 3/8 inch and extends the joints to 5/8 inch in a continuous movement at the rate of 1/8 inch per hour (Figure 6a). A total number of 10 cycles are completed. One cycle is defined as follows: compression from the nominal 1/2 inch width to 3/8 inch, followed by extension to 5/8 inch and the compression to 112 inch. At the completion of the 10 cycles extend the specimens (by hand crank) to 5/8 inch, insert spacer blocks, remove specimens and examine for bond and cohesion breaks (Figure 7e). If the specimens are rated as failure at this stage the durability test shall be terminated.
4. The final portion of the Durability test consists of compressing the specimens to 3/8 inch with "C" clamp and while in compression are exposed in the oven for 16 to 20 hours. They are then removed from the oven, cooled to standard temperature, clamps and spacer blocks removed, and placed in the extension machine located in the cold box or chamber. The specimens shall be extended to 5/8 inch while they are being cooled down to -15 deg. F.[8] The rate of extension shall be 1/8 inch per hour. On completion of the extension the specimens shall be blocked at 5/8 inch, removed from the freezer and allowed to warm up to standard temperature. Examine specimens for bond and cohesion breaks as well as permanent deformation. The daily compression-extension cycles described above are performed a maximum of 10 times or stopped at any time of failure as defined in 3.5.

4.3.9.4.1.1 Formation of bubbles. On completion of the measurements of bond, cohesion loss, and permanent deformation, each specimen shall be cut through the middle of the sealant and examined for bubbles. The presence of bubbles averaging more than 1/16 inch in diameter which cover more than half the area of the sealant exposed by the cutting shall be rated as failure. The presence of bubbles averaging 1/16 inch or less in diameter in any amount shall not be cause for failure provided the bond, cohesion, and deformation requirements are met.

4.3.9.4.2 Class B sealants. The test procedure is the same as that described in 4.3.9.4.1 with the following exceptions:

(a) All compression movements consist of 12-1/2 percent of the nominal half inch width, i.e., to 7/16 inch instead of 3/8 inch.

(b) All extension movements consist of 12-1/2 percent of the nominal half inch width, i.e., to 9/16 inch instead of 5/8 inch.

4.3.10 Adhesion in peel. This test is made on plate glass, anodized aluminum, and portland cement mortar after the test specimens have been cured for 28 days as specified herein. It is performed in a testing machine in which the sealant (sealed to cloth) is peeled back at an angle of 180 deg. at a separation rate of 2 inches per minute.[7] and [9]

4.3.10.1 Apparatus and accessory materials required are: (1) testing machine with tension grips capable of pulling at a rate of separation of 2 inches per minute with a dial or chart indicator calibrated in 1 pound units;

(2) two 6 by 3 inch pieces of anodized aluminum (same type as described in section 4.3.9.2.3); (3) two pieces of 1/4 inch polished plate glass about 6 by 3 inch; (4) two 6 by 3 by 3/8 inch mortar slabs prepared as described in 4.3.9.2.1 except for size; (5) desized grade A airplane fabric, 4.28 ounces per yard, 80/84 count, or any suitable cloth that will adhere to the sealant (six 6 by 3 inch pieces); (6) paper masking tape, 1 inch wide.

Before constructing the test assemblies, clean the aluminum and glass substrates as specified for the steel channel in 4.3.2.1 [10]. Clean mortar substrates as specified in 4.3.9.2.1 [11]

- [7] If manufacturer's directions for use of the sample indicate that the compound shall not be used in joints with porous substrates do not include standard mortar or any other porous substrate such as brick, limestone, marble, etc. in the test.
- [8] Regardless of the amount of recovery of the sealant after the "C" clamps are removed, the jaws of the extension machine shall be set at 3/8 inch before extension is started in the freezer. For Class B sealants the jaws shall be set at 7/16 inch.
- [9] Other substrates shall be used in the test in place of or in addition to the standard materials when requested by the purchaser.
- [10] At the request of the sealant manufacturer the detergent cleaning step shall be omitted from the specified cleaning procedure.
- [11] All non-porous substrate materials shall be cleaned as specified for steel channel, in 4.3.2.1 except as indicated in footnote<sup>L10</sup>. Porous accessory blocks, other than standard mortar shall be dried and cleaned as specified for mortar in 4.3.9.2.1.

TT-S-001543A(COM-NBS)

Place a strip of 1 inch paper masking tape across the width of the plate so that the lower edge of the tape is parallel to the lower edge of the plate and 2 inches above it (Figure 8A). After conditioning not less than 250 grams of compound in a closed container for 24 hours at standard conditions, spread a portion on the surface of the plate to a thickness of 1/8 inch over an area from the top edge of the tape to the bottom of the plate and the entire width of the plate (Figure 8B). The cloth, approximately 6 by 3 inches is smeared with the compound at one end over an area of 3 by 3 inches and forced into the cloth using a spatula. The impregnated cloth is laid over the 1/8 inch layer of compound without entrapping air. Then the assembly is placed between 1/16 inch spacer bars and the surface of the cloth rolled with a glass rod so that the thickness of the compound between the cloth and the surface is 1/16 inch (Figure 8C).

Prepare two aluminum, glass and mortar specimens as described above for each sample of sealant. Apply primer to the dry surfaces only when specified and supplied by the manufacturer and agreed upon by the purchaser.

After preparation allow the test specimen to cure for 21 days as specified in 4.3.4.2, followed by an additional 7 days curing while completely immersed in distilled or deionized water at standard temperature after the specimen has cured about 7 days (during the 21 days cure period) coat the cloth with a thin layer (about 1/32 inch) of the compound in order to minimize cloth adhesion failure after water immersion (Figure 8D).

After 21 days curing and immediately before immersing the specimen in water for 7 days, the surface of the fabric shall be cut through to the base surface with a sharp razor blade leaving two strips of sealant and fabric 1 inch wide, separated by a space approximately 3/8 inch wide (Figure 8E).

Immediately following the 28 day cure, prepare the specimen for testing by wiping it dry and releasing 1 inch of cloth and masking tape from base. Then place the specimen in the testing machine and peel the cloth back at an angle of 180 deg. (Figure 9). The rate of separation of the jaws of the machine shall be 2 inches per minute. Pull the sealant for 1 minute, and note the average value in pounds indicated by a dial or recording chart on the machine. If the cloth peels from the sealant, during testing, disregard the values. In such instance cut the compound across with a sharp razor blade in order to get separation at the interface to the test surface.

Test four strips for each base material (aluminum, glass, etc.) and record the peel value in pounds for each strip as well as the average peel value for each substrate.

4.4 Adhesion-in-peel after ultra-violet radiation exposure through glass.[12] Prepare and cure two plate glass peel strength specimens as specified in 4.3.10.1. At the end of the 28 day cure period (water immersion included where applicable), place the test specimens with the sealant surface facing away from the light source on the drum of an accelerated weathering machine as specified in 4.3.7. Expose the specimens to the UV radiation for 200 hours with or without water spray. Following the exposure, immerse the specimens in distilled or deionized water for 7 days and obtain peel strength and record data as prescribed in 4.3.10.1.

## 5. PREPARATION FOR DELIVERY

5.1 Unit packaging. The compound shall be furnished in quantities of approximately 1/10 gallon in cartridges. The cartridges shall be resistant to ambient humidity for a period of not less than six months. The inner surfaces to the cartridges shall be impervious to the compound and provide

adequate protection for the product packaged for the six month period described herein.

5.2 Intermediate packaging. Intermediate packaging shall be level A, B, or C, as specified (see 6.2 ).

5.2.1 Level A. Twelve (12) filled cartridges shall be packaged in a close-fitting box conforming to PPP-B-636, class weather-resistant. Each cartridge shall be inserted in a full height cell formed by slotted fiberboard or polystyrene partitions. The fiberboard shall meet the requirements of PPP-F-320, class domestic, type CF, variety SW, grade 200. The box shall be closed and waterproof sealed in accordance with the appendix to PPP-B-636.

5.2.2 Level B. Twelve (12) filled cartridges shall be packaged in accordance with 5.2.1, except that the box shall be in accordance with PPP-B-636, class-domestic and shall be closed and sealed in accordance with method II of the appendix to PPP-B-636.

[12] The test shall be performed when the sealant bonding area to glass may be adversely affected by the sun's rays passing through the glass.  
The test shall be requested by the purchaser.



TT-S-001543A (COM-NBS)

5.2.3 Level C. Twelve (12) filled cartridges shall be packed in containers in accordance with the manufacturer's standard practice, providing this insures protection of the cartridges during shipment and safe delivery to their destination.

5.3 Packing. The packing shall be level A, B, or C, as specified (see 6.2).

5.3.1 Level A.

5.3.1.1 Cartridges. Unless otherwise specified, four intermediate packages (48 cartridges) shall be packed in a close-fitting box conforming to PPP-B-585, class 3; PPP-B-601, overseas type; PPP-B-621, class 2; PPP-B-636, type CF, class weather-resistant; variety SW, grade V3c; or PPP-B-640, class 2. The box shall be closed and strapped in accordance with the appendix to the applicable box specification. The gross weight, when using the PPP-B-636 box, shall not exceed the weight limitations of the box specification. When the gross weight of the wood or triple-wall fiberboard boxes exceeds 250 pounds, skids shall be provided in accordance with the applicable specification.

5.3.1.2 Metal containers. The compound furnished in quantities as specified (see 6-2) shall be packed in a close fitting pail conforming to PPP-B-704, type II, class 1, 2, 3 or 4.

5.3.2 Level B.

5.3.2.1 Cartridges. Four intermediate packages (48 cartridges) shall be packed in a closefitting box conforming to PPP-B-636, class-domestic. The box shall be closed in accordance with method I of the appendix to PPP-B-636.

5.3.2.2 Metal containers. The compound furnished in quantities as specified (see 6.2) shall be packed as specified in 5.3.1.2 except that the exterior side seam coating shall not be required.

5.3.3 Level C.

5.3.3.1 Cartridges. Four intermediate packages (48 cartridges) shall be packed in a closefitting box of the type normally used for the product. Containers shall comply with the National Motor Freight Classification rules and the Uniform Freight Classification rules.

5.3.3.2 Metal containers. The compound furnished in quantities as specified (see 6.2) shall be packed in containers of the type normally used for the product. Containers shall comply with the National Motor Freight Classification and the Uniform Freight Classification rules.

5.4 Marking. Marking shall be in accordance with paragraph 5.4.1 or 5.4.2, as applicable.

5.4.1 Civil agencies. In addition to markings required by the contract or order, the interior packages and shipping containers shall be marked in accordance with Fed. Std. No. 123, and shall include the date of manufacture by month and year not by code.

5.4.2 Military agencies. In addition to markings required by the contract or order, the interior packages and shipping containers shall be marked in accordance with MIL-STD-129, and shall include the date of manufacture by month and year not by code.

NOTES

## 6.1 Intended use.

6.1.1 The joint sealing compound covered by this specification is intended to seal joints in all types of structures where some movement is expected and where tightness against dust, dirt, wind, and water is required. Some of the uses of the compound as a sealer include channel glazing, bedding and sealing around panels and lights of curtain wall structures, sealing window and door perimeters, sealing the joints between precast concrete panels, sealing flashings and expansion joints, and pointing brick and stone masonry. Producers of silicone rubber base joint sealers list many other and varied uses for this type of sealer.

6.1.2 The compound is supplied as a one-component material in foil-wrapped or plastic cartridges as well as in bulk containers of various capacities.

TT-S-001543A(COM-NBS)

6.1.3 The compound supplied in cartridges shall be installed with either a hand or power gun. Bulk compound shall be installed with a calking gun or with a handtool. It is of prime importance that the joint be dry and free of dust, dirt, oil, grease, or old loose calking before the compound is placed in the joint.

6.1.4 The compound shall not be applied to surfaces coated with lacquer or paint. Such coatings shall be removed before applying the compound. Before applying the compound to masonry joints previously treated with water repellent solutions, a laboratory test for bond shall be made as described in 4.3.9, using the specified type masonry and water repellent solution as accessory materials. It is recommended that the sealing compound producers be consulted before applying a compound to concrete treated with retardants surface curing and mold release agents.

6.1.5 Unless specifically agreed upon by supplier and purchaser, the compound shall not be applied in contact with joint fillers such as asphaltic materials, oil base calkings, or any other sealants in which the bonding properties and adverse effects resulting from the combination are not known. The producer shall be consulted before a compound is applied to factory-enameled aluminum or steel surfaces.

6.1.6 Producers often recommend the use of a specific primer or surface conditioner for specific surfaces. The primer or conditioner is designed to assure adhesion of the compound to a specific surface. In all cases where primers or conditioners are recommended with a compound it is advisable to have the durability and peel strength tests made with the primer in question. Substituted primers or conditioners other than those recommended by the producer shall not be used.

6.1.7 Although silicone building sealants can be gunned at ambient temperatures as low as -20 deg. F., a film of moisture may form on cold substrates which can prevent a strong bond with the sealant. Therefore, necessary steps should be taken in such cases to dry the substrate.

6.1.8 Wherever possible a back-up material should be used with sealant in a moving joint to insure good bond to sides of the joint. The back-up material should be completely inert, nonrigid, and also shall not form a strong bond to the sealant itself. The sealant producer should recommend the proper back-up material for his product for a particular substrate and joint design.

6.1.9 Silicone base compounds are available in several colors. Producers do not recommend painting of the sealant.

6.1.10 Modification of a compound by the addition of liquids or powders to alter the flow properties shall not be permitted, Other suitable flow characteristics than those specified herein may be agreed upon by the supplier and purchaser. Special non-sag properties may be required in unusually large joints and lesser flow characteristics may be required in sloping joints where perfect leveling is not desired.

6.1.11 A compound shall not be used on any job if the date of manufacture indicates that the compound is more than 12 months old.

6.1.12 This specification covers joint sealants which are capable of resisting joint movements not exceeding a total of 50 percent of the nominal joint width for class A sealants, and a total of 25 percent for class B sealants (see footnote [1] and [2]).

6.2 Ordering data. Purchasers should select the preferred options permitted

herein and include the following information in procurement documents:

- (a) Title, number, and date of this specification.
- (b) Class of product required (see 1.2).
- (c) Color of compound required (see 3.5).
- (d) Selection of applicable levels of packaging and packing required (see 5.2 and 5.3).
- (e) Quantity of unit packages required in shipping container (see 5.3.1.2, 5.3.2.2, and 5.3.3.2).

6.3 Toxicity. Any questions raised regarding toxicity should be referred by the procuring activity to the departmental medical authority. In any case of Army procurement, the Surgeon General will act as advisor to the procuring activity.

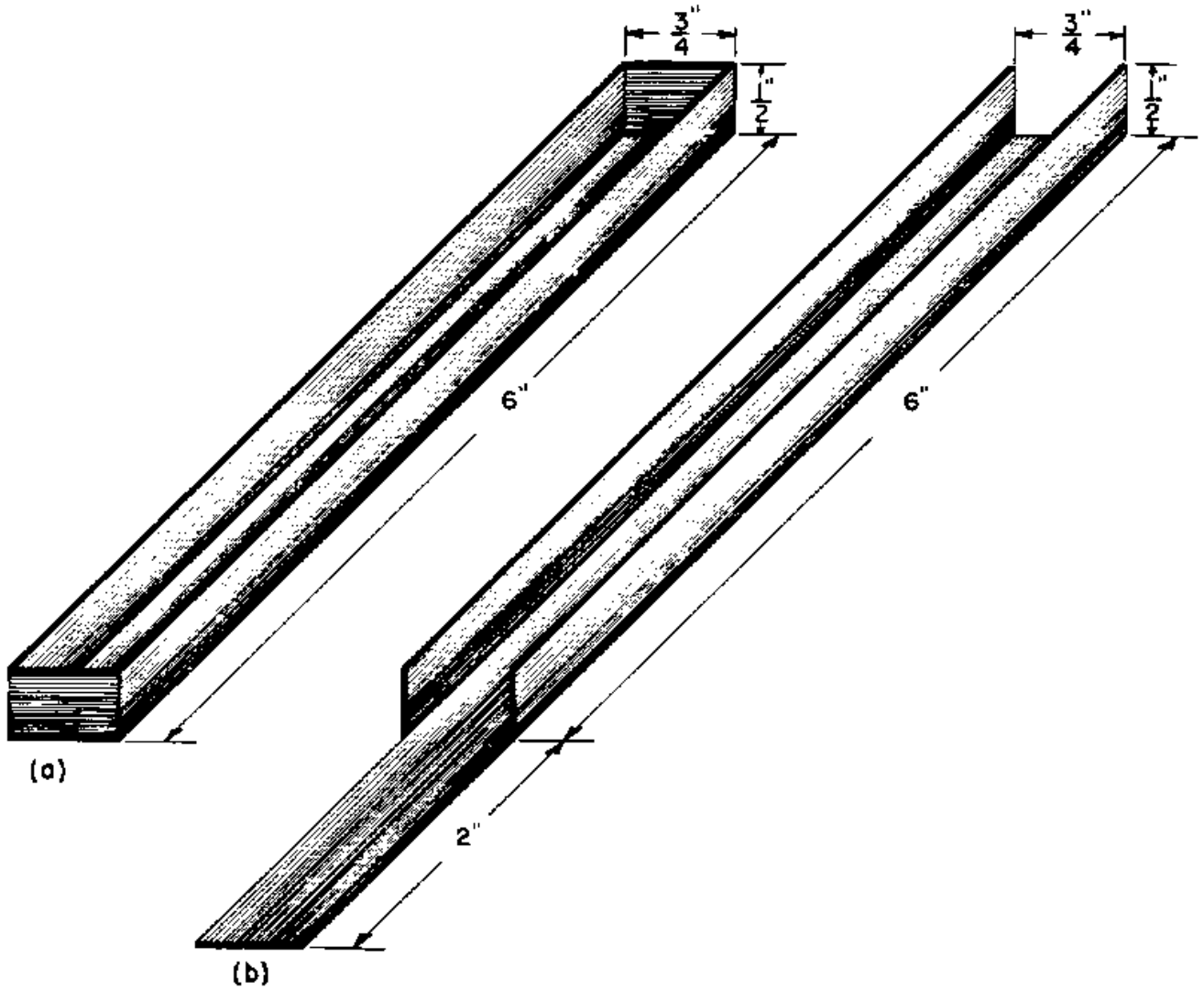

FIGURE 1. Channels used for determining rheological properties,  
(a) for self leveling or flow type compound (type 1),  
(b) for non-sag type compound (type 2).  
(c) Channel (a) is not applicable in this specification.

TT-S-001543A (COM-NBS)

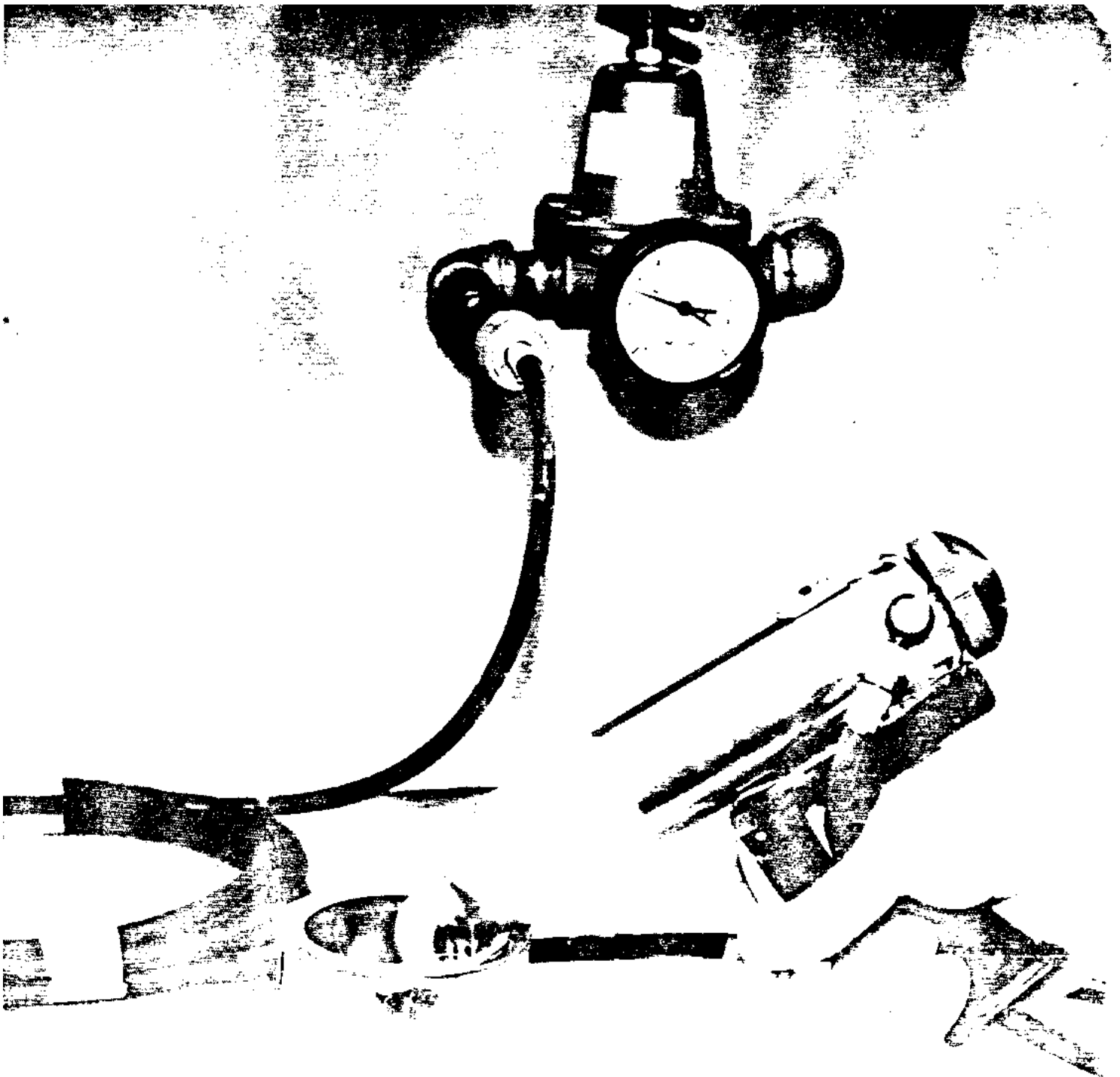

FIGURE 2. Extrusion rate test using a 6 ounce power gun containing 6 ounce cartridge without added nozzle, and operated at 50 p.s.i.

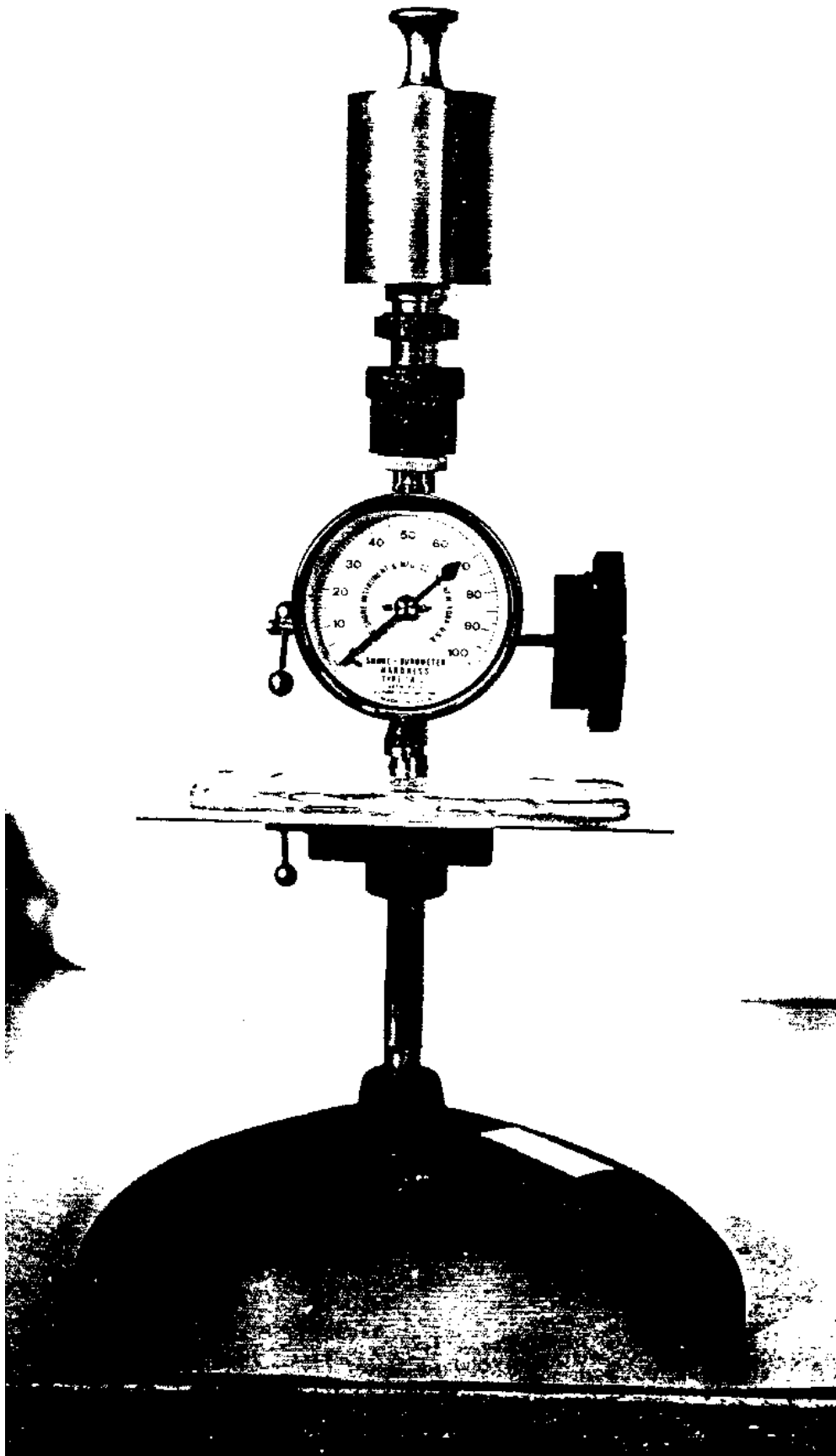

FIGURE 3a. Durometer fitted to operating stand with 822 gram load, for hardness determination.

TT-S-001543A (COM-NBS)

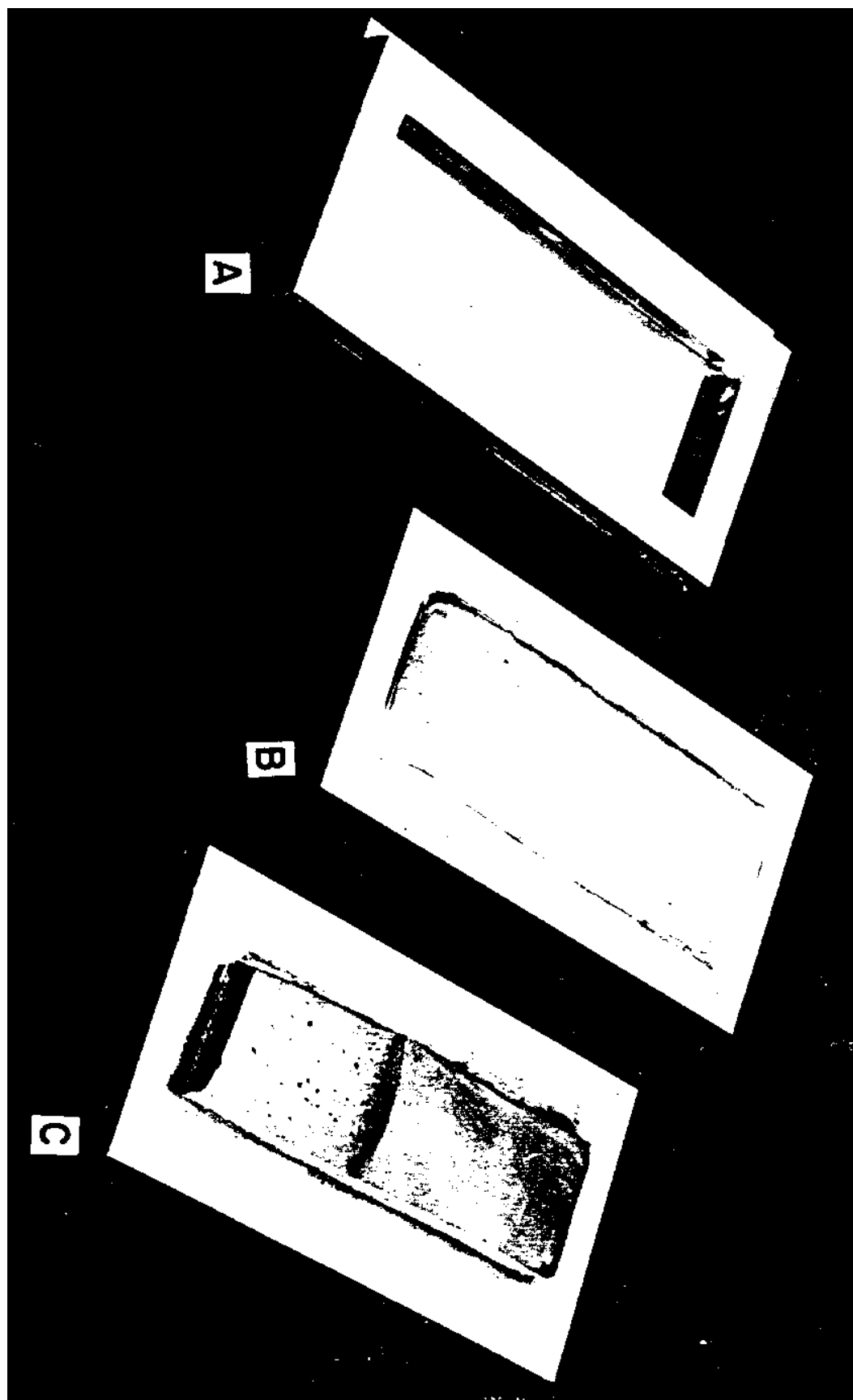

FIGURE 3b. Stages in the preparation of hardness test specimen.  
(A) frame,  
(B) specimen for hardness test at standard conditions,  
(C) not applicable in this specification.





FIGURE 4. Stages in the tack free time test procedure.

TT-S-001543A (COM-NBS)

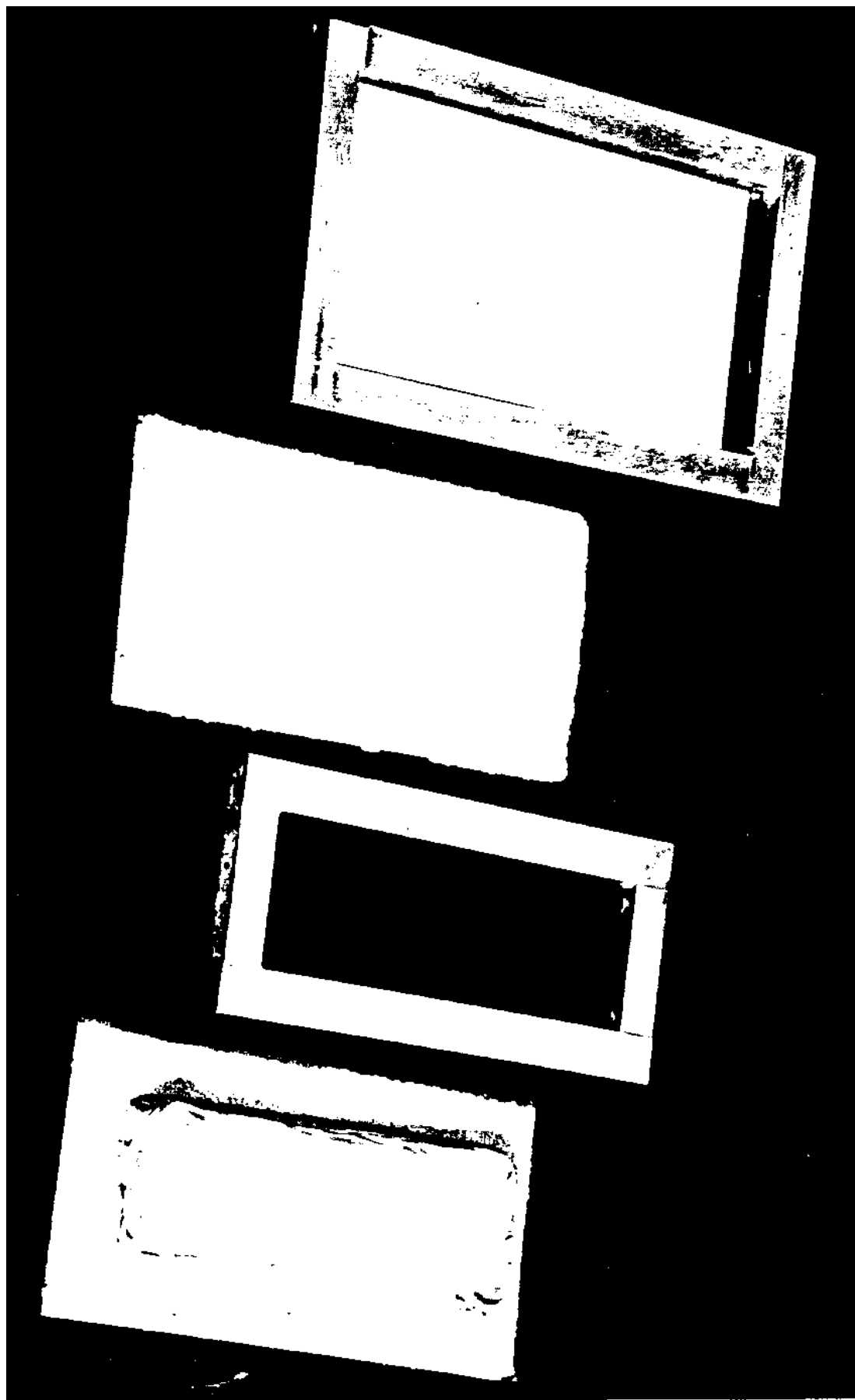

FIGURE 5. Stages in the preparation of the stain test specimen.

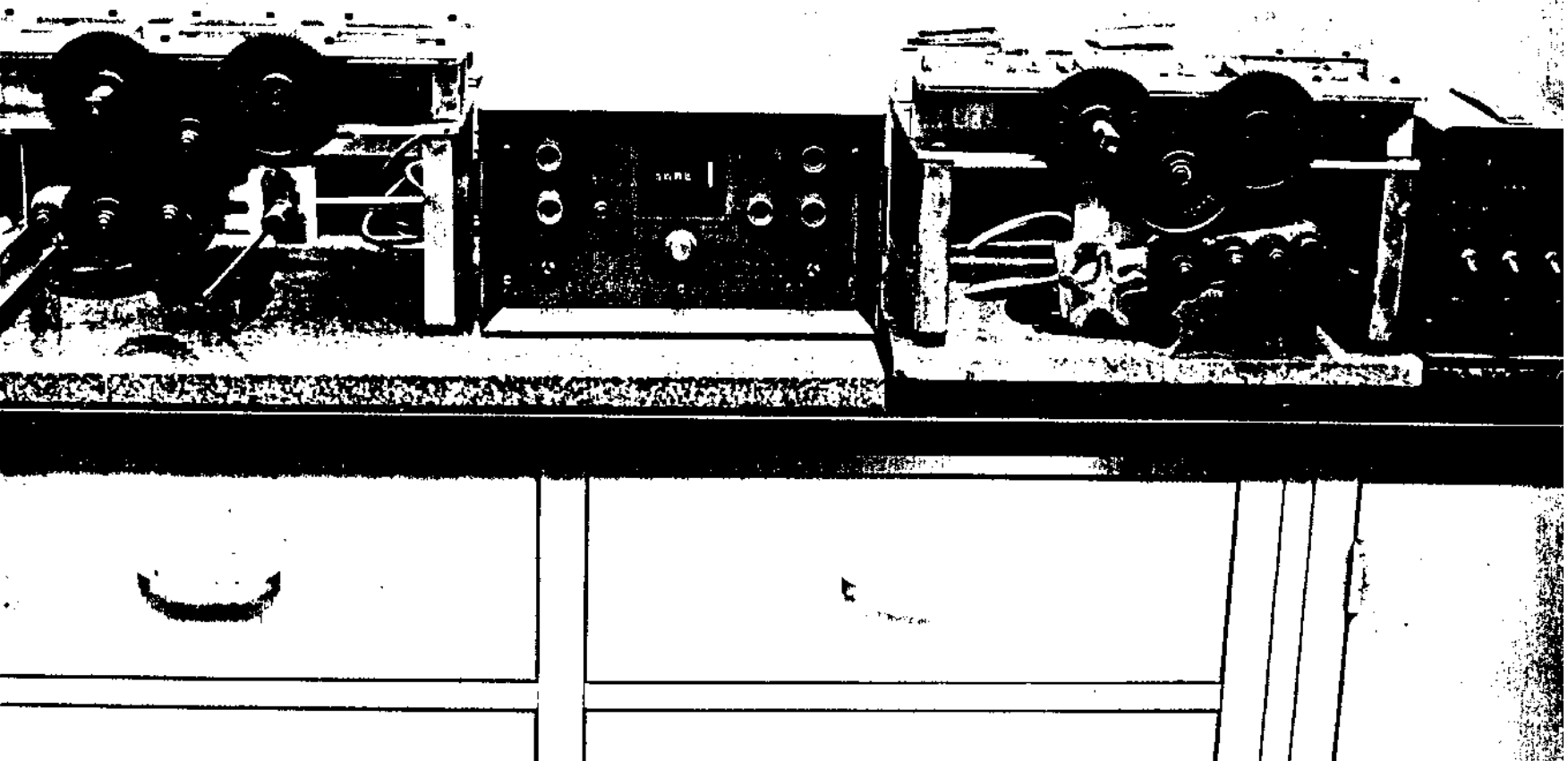

FIGURE 6a. Compression-extension machines with automatic control units, used in the Durability test.

TT-S-001543A (COM-NBS)

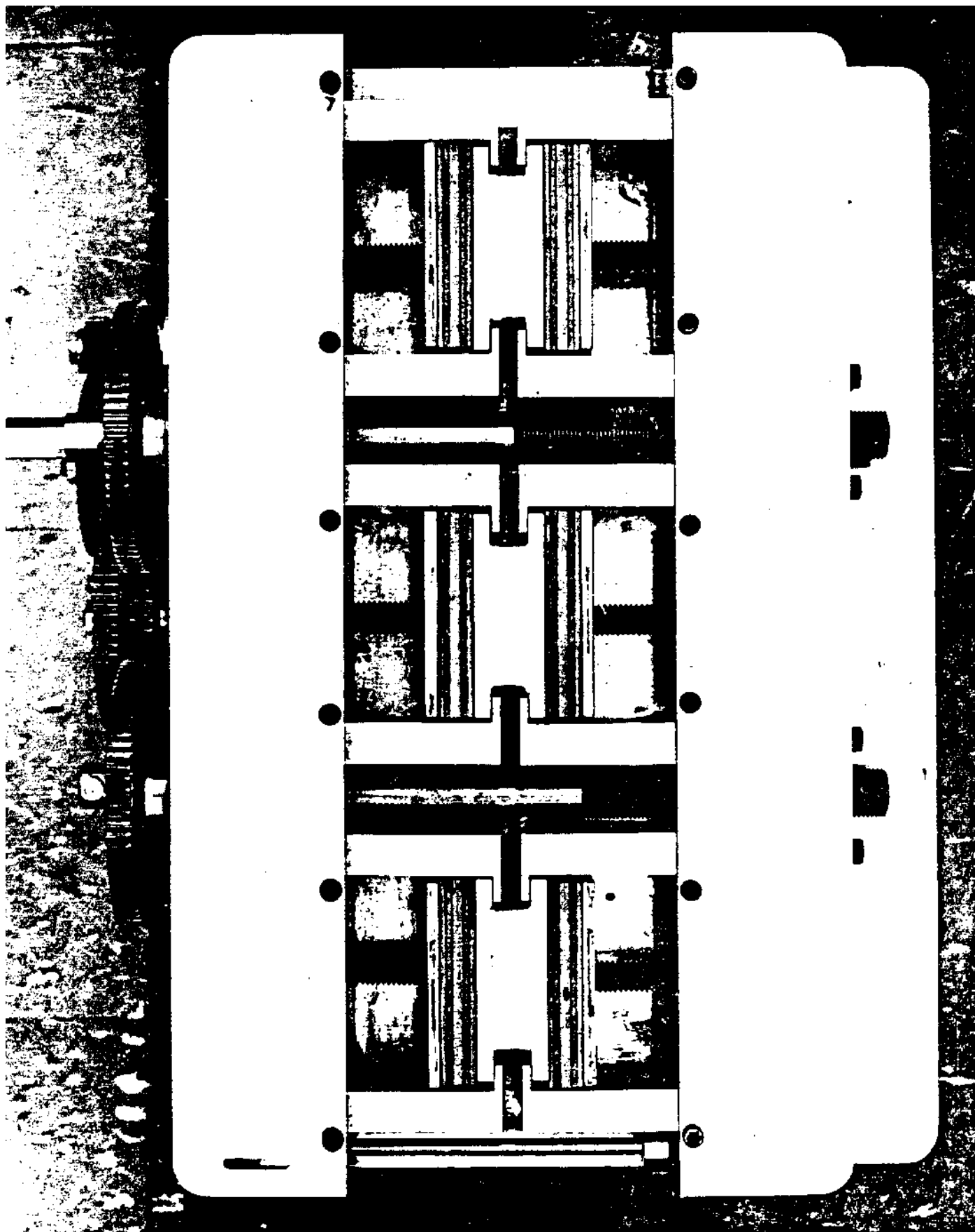

FIGURE 6b. Top view of the machine noted in 6a, showing 3 specimens ready for automatic compression-extension cycling. Also noted are cushioning blocks and pressure plates.

TT-S-001543A (COM-NBS)

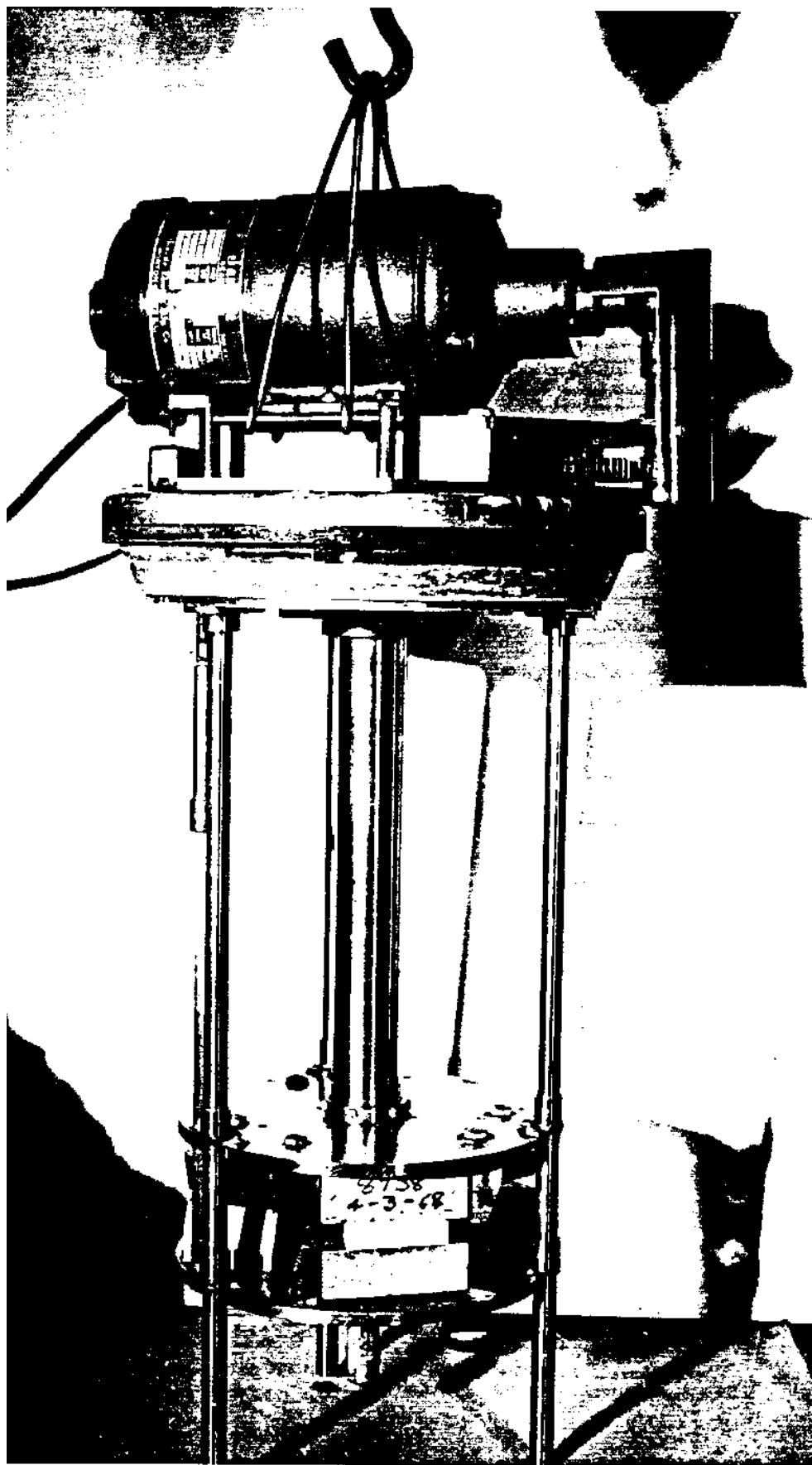

FIGURE 6c. A motor driven machine used for extension of specimens at  $-15^{\circ}\text{F}$ . in the Durability test.

### Durability Specimens For Class A and B Sealants

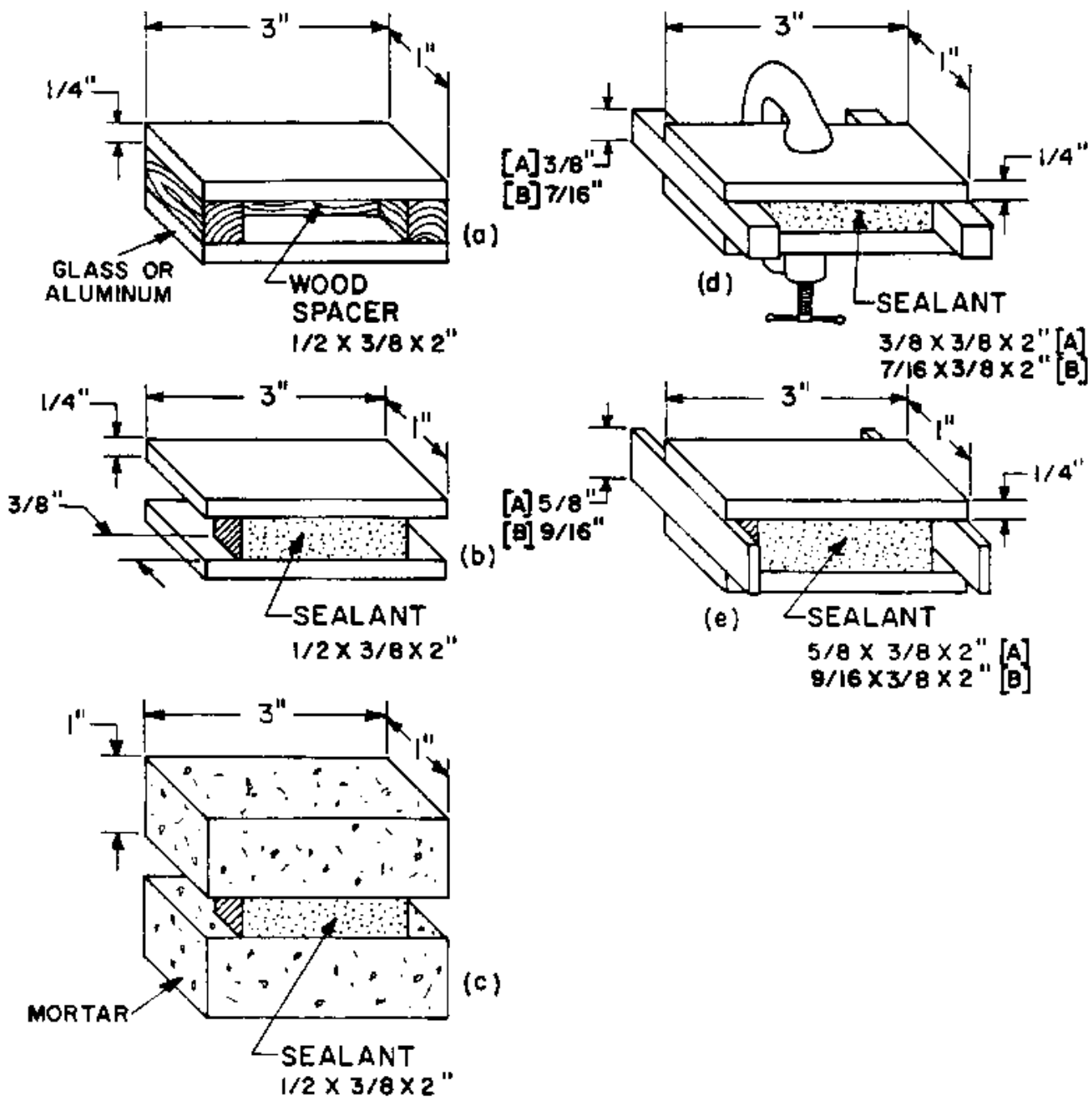

FIGURE 7. Test specimens used in Durability test  
 (a) prepared specimen before placement of sealant,  
 (b) sealant with spacers removed,  
 (c) sealant between mortar blocks,  
 (d) sealant in the compressed state during heat treatment,  
 (e) sealant in the extended state.

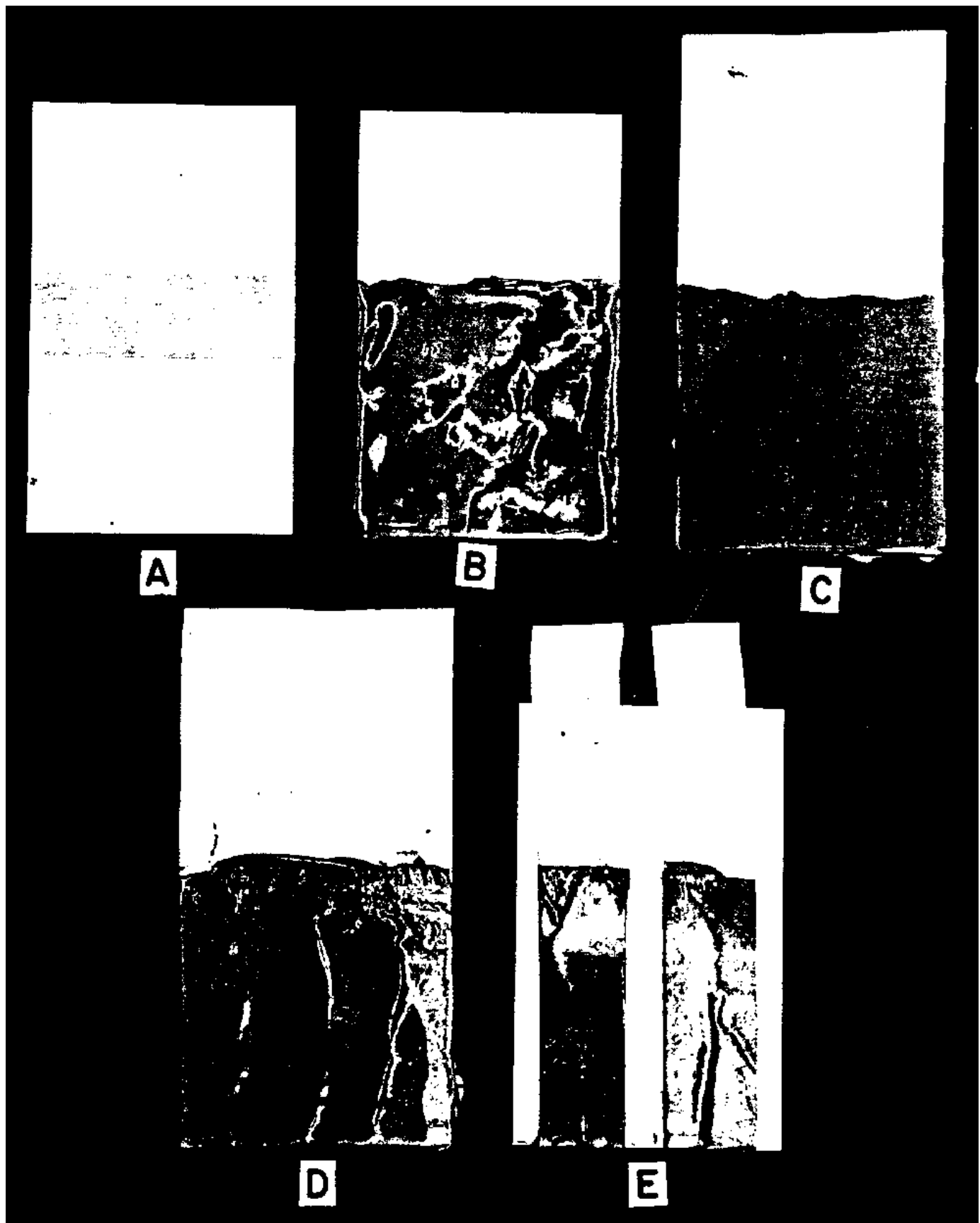

FIGURE 8. Stages in the preparation of the adhesion in peel test specimen.

TT-S-001543A (COM-NBS)

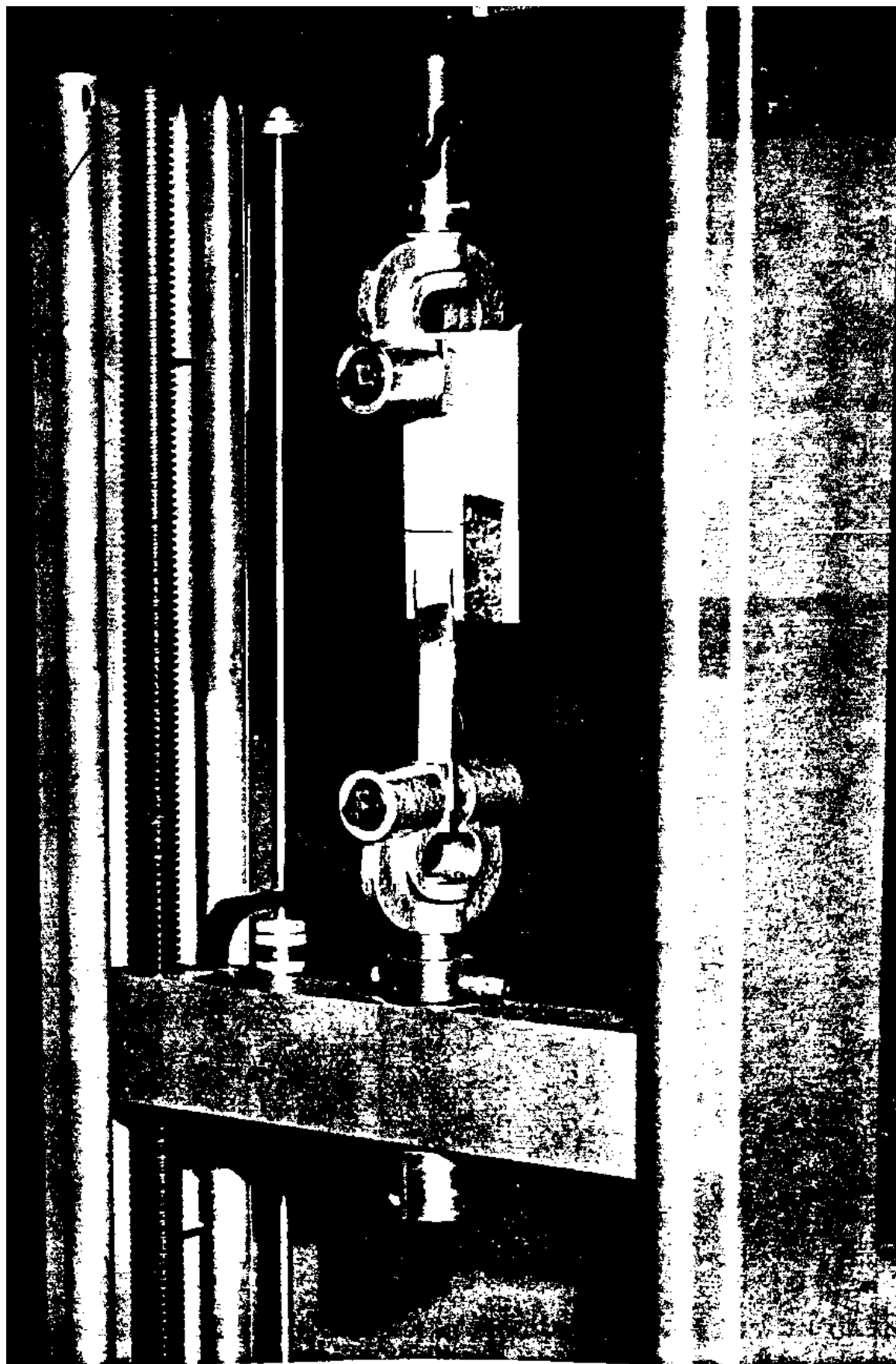

FIGURE 9. Extension machine used in the adhesion in peel test.