

RR-R-1102D
February 28, 1977
SUPERSEDING
Fed. Spec. RR-R-1102C
February 7, 1972
Int. Fed. Spec. UU-T-00670A
June 14, 1968

FEDERAL SPECIFICATION

HANGERS, CLOTHES; AND ACCESSORIES

This specification was approved by the Commissioner, Federal Supply Service, General Services Administration, for the use of all Federal agencies.

1. SCOPE AND CLASSIFICATION.

1.1 Scope. This specification covers wood, plastic, and all wire clothes hangers; and trouser guards.

1.2 Classification. Clothes hangers and accessories shall be of the following types, as specified (see 6.2).

Item 1: Hangers;

Type I - Wood or plastic clothes hanger with steel wire suspension hook.
Type II - All wire clothes hanger.

Item 2: Accessory;

Type III - Trouser guard (for use with type II clothes hanger).

2. APPLICABLE DOCUMENTS

2.1 The following documents, of the issues in effect on date of invitation for bids or request for proposal, form a part of this specification to the extent specified herein.

Federal Specification:

PPP-B-636 - Box, Fiberboard.

Federal Standard:

Fed. Std. No. 123 - Marking for Shipment (Civil Agencies).

(Activities outside the Federal Government may obtain copies of Federal Specifications, Standards, and Handbooks as outlined under General Information in the Index of Federal Specifications and Standards and at the prices indicated in the Index. The Index, which includes cumulative monthly supplements as issued, is for sale on a subscription basis by the Superintendent of Documents, U.S. Government Printing Office, Washington, DC 20402.

(Single copies of this specification and other Federal Specifications required by activities outside the Federal Government for bidding purposes are available without charge from Business Service Centers at the General Services Administration Regional Offices in Boston, New York, Washington, DC, Atlanta, Chicago, Kansas City, MO, Fort Worth, Denver, San Francisco, Los Angeles, and Seattle, WA.

(Federal Government activities may obtain copies of Federal Specifications, Standards, and Handbooks and the Index of Federal Specifications and Standards from established distribution points in their agencies.)

Military Standards:

MIL-STD-105 - Sampling Procedures and Tables for Inspection by Attributes.
MIL-STD-129 - Marking and Shipment and Storage.
MIL-STD-1363 - Measurement of Wood Moisture Content.

RR-W-1102D

(Copies of Military Specifications and Standards required by suppliers in connection with specific procurement functions should be obtained from the procuring activity or as directed by the contracting officer.)

2.2 Other publications. The following documents form a part of this specification to the extent specified herein. Unless a specific issue is identified, the issue in effect on date of invitation for bids or request for proposal shall apply.

Technical Association of the Pulp and Paper Industry (TAPPI) Standard:

T 411 OS-68 - Thickness (Caliper) of Paper and Paperboard.

(Application for copies should be addressed to the Technical Association of the Pulp and Paper Industry, 360 Lexington Avenue, New York, NY 10017.)

National Motor Freight Traffic Association, Inc., Agent:

National Motor Freight Classification.

(Application for copies should be addressed to the American Trucking Associations, Inc., Traffic Department, 1616 P Street, N.W., Washington, DC 20036.)

Uniform Classification Committee, Agent:

Uniform Freight Classification.

(Application for copies should be addressed to the Uniform Classification Committee, Room 1106, 222 South Riverside Plaza, Chicago, IL 60606.)

3. REQUIREMENTS

3.1 Hangers.

3.1.1 Material.

3.1.1.1 Wood. Wood used in type I hangers shall be any of the following species: Red alder, beech, birch, cherry, gum, or maple. When tested as specified in 4.4.1.1, wood shall have a moisture content not less than 12 percent. When visually examined, wood and finished members shall be free of defects in accordance with the following:

- (a) Sound, tight knots, not over 3/8 inch in diameter, shall be acceptable, provided they are not in clusters and not more than two per member. Knots in members shall not be closer than 2 inches from the ends, and shall not be permitted near the narrowest portion of the member or in the rod;
- (b) Figure grain and discoloration due to mineral streaks and light stain shall be acceptable.

3.1.1.2 Plastic. Plastic used in type I hanger shall be any suitable polymer to meet the requirements of this specification. The plastic material may be any opaque or solid color, at the manufacturer's option.

3.1.1.3 Wire, steel.

3.1.1.3.1 Type I. Wire used for the suspension hook of the type I hanger shall be nominal 11 gauge, cold-drawn, low carbon steel with a silver bright galvanized finish and with a temper of hard-galvanized wire. In no case, however, shall the diameter of the wire be less than 0.128 inches.

3.1.1.3.2 Type II. Wire used for the complete type II hanger shall be nominal 13 gauge, cold drawn, low carbon steel with a clean bright finish. In no case, however, shall the diameter of the wire be less than 0.0895 inches.

3.1.2 Construction. Clothes hangers shall be constructed as specified herein. Type I hangers shall conform to the dimensions and, in general, to the design and shape shown in Figure 1. Type II hangers shall conform to the design, shape, and dimensions shown in Figure 1. When viewed from the end, hangers shall have a flat profile (i.e. all hanger members shall be straight, and shall lay in essentially the same, flat plane).

RR-H-110ZD

3.1.2.1 Type I, wood. Wooden hangers shall consist of two side pieces, a trouser rod, and a suspension hook. Wooden components shall be any of the species specified in 3.1.1.1. The side pieces shall meet at the top, forming either a flush or dovetail joint in the center of the hanger. The flush joint shall be held together with four corrugated steel strips, two on each flat side of the hanger, driven flush into the wood. The dovetail joint shall be held together by the interlocking tenons at the center of the hanger and shall be bonded with a thermosetting resin adhesive, in accordance with regular commercial practice. The spread shall be maintained by the hard wood rod, smoothly doweled into the side pieces. One end of the rod may be secured by a galvanized or tinned brad, at the option of the manufacturer. The top edges of the side (shoulder) pieces shall be smoothly rounded to prevent damage to clothing. An alternate design, utilizing a singly-cut shoulder-bar piece, with trouser bar doweled into the ends, shall be acceptable, provided that compliance is maintained with all other applicable requirements of this document.

3.1.2.2 Type I, plastic. Plastic hangers shall consist of a singly-molded unit body (shoulder pieces and trouser bar) and a suspension hook, or may consist of a separately molded shoulder-piece unit and trouser bar, plus the suspension hook. In the latter construction, the trouser bar shall be made of the same material as the shoulder-piece unit, and shall be permanently attached in such a manner that it becomes a fixed, integral part of the hanger, not meant to be snapped out at either end. Additional clothes attachment accessories shall not be acceptable.

3.1.2.3 Type I, suspension hooks. The hook shall be made of the steel specified in 3.1.1.3.1. The hook shall swivel and be headed at the bottom to prevent pulling out, and may either go through the hanger or terminate within the junction or peak of the shoulder piece(s). The upper end of the hook may be plain or looped back, at the manufacturer's option. Suspension hooks shall be able to fit completely over a 1-1/2 inch diameter bar without binding. Long-necked suspension hooks shall not be acceptable.

3.1.2.4 Type II. Type II hangers shall be made of the steel wire specified in 3.1.1.3.2.

3.1.3 Finish.

3.1.3.1 Type I. If made of wood, the wooden portions of the hanger shall be smoothly sanded and no protective coating of any kind shall be applied. If made of plastic, the plastic portions of the hanger may be smooth, or completely or partially textured in accordance with the manufacturer's standard practice. The wire portions of the type I hangers shall be galvanized, as specified in 3.1.1.3.1. Strict compliance with 3.1.5 shall be maintained at all times.

3.1.3.2 Type II. Type II hangers shall be coated with black enamel, or with gold enamel or lacquer in a continuous coating which shall be free from tackiness and brittleness (as determined by the presence of flaked or blistered areas). When tested as specified in 4.4.1.4, the base metal shall not be exposed except where actual contact has been made with the sharp edge of the knife blade. When tested as specified in 4.4.1.3, there shall be no residue on the white cloth.

3.1.3.2.1 Hot-water resistance. When type II hangers are tested as specified in 4.4.1.5, the coating of the immersed portion shall be equal in hardness and adhesion to that of the unimmersed portion; it shall not be soft or smearable, nor shall it blister or become flaky.

3.1.3.2.2 Heat resistance. When type II hangers are tested as specified in 4.4.1.6, the coating shall not run or sag during the heating period; it shall not show blistering, cracking or flaking after the hangers are allowed to cool at room temperature.

3.1.4 Performance.

3.1.4.1 Static loading (Types I and II). When tested as specified in 4.4.1.2(a), the maximum deflection of the trouser bar, for both type I and II hangers, shall not be greater than 1/2 inch. When type I and II hangers are tested as specified in 4.4.1.2(b), there shall be no appreciable deformation or evidence of permanent damage.

3.1.4.2 Dynamic loading (type I only). When type I hangers are tested as specified in 4.4.1.2(c), no damage shall occur which would impair the hanger for its intended use.

3.1.5 Workmanship. The finished hangers shall be free from any splinters, sharp edges, projections, molding residue or other defects that might snag or tear garments. Surfaces shall be free from flaws, cracked or peeling enamel or lacquer, or other defects which might impair its serviceability or appearance.

EE-H-1102D

3.2 Trouser guards.

3.2.1 Material. Trouser guards shall be made from paperboard or chipboard, and shall be free of surface contaminants of asphalt, wax, or other transferable matter. The material shall be the natural color of its constituents and shall contain no transferable dyes. When tested as specified in 4.4.2.2, no material shall be transferred from the guard to the cloth, nor shall there be material transfer from the test cloth to the guard.

3.2.2 Design and construction. Trouser guards shall be designed to cover the horizontal wire of the type II clothes hanger (see 1.2 and figure 1.), and shall be shaped to give a curved support to trousers hung thereon. The design of the guard shall be such that there shall be no contact with any sharp edges of the guard that would cause creasing of the trousers. The guard shall be processed to minimize slippage of trousers from the guard. The ends of the guard shall be provided with a locking slot to fit snugly to the riser portions of the type II hanger, to keep the guard in place while inserting or removing trousers.

3.2.2.1 Nonstick application. A latex or abrasive strip, $1/4 \pm 1/16$ inch wide, shall be applied along the longitudinal axis of the guard, equidistant from the edges. If abrasive material is used, it shall be non-crystalline.

3.2.3 Dimensions.

3.2.3.1 Length. The overall length of the guards, including the two end locks, shall be $16-7/8 \pm 1/8$ inches. The supporting length of the guards shall be such that it will not buckle when placed on a type II clothes hanger.

3.2.3.2 Thickness. The guards shall be $0.021 \pm .002$ inch thick, when tested as specified in 4.4.2.1.

3.2.3.3 Width. The supporting surface of the guards shall be $1-1/4 \pm 1/8$ wide.

3.2.3.4 End slots. The ends of the guards shall be slotted with a serrated cut $3/4 \pm 1/16$ inch long, equidistant from the edges, so as to fully secure the guard to the riser portions of the type II clothes hanger.

3.2.4 Flexibility. The guard shall be flexible to the extent that it can be applied to a type II hanger with the lock ends returning to a position that will fully secure the guard to the hanger, without buckling the guard.

3.2.5 Workmanship. The guards shall be cleanly cut and free from lint, dirt, or other defects which would mar its appearance or affect its serviceability.

4. QUALITY ASSURANCE PROVISIONS

4.1 Responsibility for inspection. Unless otherwise specified in the contract or purchase order, the contractor is responsible for the performance of all inspection requirements as specified herein. Except as otherwise specified in the contract or order, the contractor may use his own or any other facilities suitable for the performance of the inspection requirements specified herein, unless disapproved by the Government. The Government reserves the right to perform any of the inspections set forth in the specification where such inspections are deemed necessary to assure that supplies and services conform to prescribed requirements.

4.2 Sampling and examination.

4.2.1 Dimensional and visual examination of end items. Clothes hangers and trouser guards shall be examined for defects listed in table I. All aspects of this examination shall be conducted in accordance with MIL-STD-105. The inspection level shall be S-3. The acceptable quality level (AQL) shall be 2.5 for major defects and 6.5 for total defects, expressed in terms of percent defective.

4.2.2 Sampling for tests. Sampling for tests shall be conducted in accordance with MIL-STD-105. The inspection level shall be S-3. The AQL for tests shall be 4.0, expressed in terms of percent defective.

RR-H-1102D

TABLE I. Classification of defects, and items

Defects	Major	Minor
<u>Types I, II, and III</u>		
Type not as specified.....	X	
Material not as specified.....	X	
Finish not as specified.....	X	
Dimensions and tolerances not as specified.....	X	
Workmanship not as specified.....	X	
<u>Type I (Wood and Plastic)</u>		
Incorporates a contoured design.....	X	
Hook does not swivel, or is not beaded at bottom to prevent pulling out.....	X	
Hook is long-necked type.....	X	
Hook does not fit over 1-1/2 inch diameter bar without binding.....	X	
<u>Type I (Wood only)</u>		
Knot holes, loose knots, knots over 3/8 inch in diameter.....	X	
Knots located near ends of hanger members other than trouser bar.....	X	
Any knots in trouser bar.....	X	
Any hanger member not smoothly sanded.....	X	
Top edge of shoulder piece(s) not rounded to prevent damage to garments.....	X	
*Shoulder pieces not forming a flush joint at center of hanger.....	X	
*Center joint not secured with 4 corrugated steel strips.....	X	
*Less than 2 steel strips on each flat side of hanger, or strips not driven flush.....	X	
*Corrugated steel strips do not join shoulder pieces securely.....	X	
Spread of hanger not maintained by rod doweled into shoulder piece ends.....	X	
Trouser rod not <u>smoothly</u> doweled into, or protrudes through, shoulder piece end(s).....	X	
<u>Type I (plastic only)</u>		
Any sharp edges or points.....	X	
Trouser bar missing, or not permanently fixed.....	X	
Trouser bar not made of same material as shoulder-piece unit.....	X	
Hanger incorporates additional clothes attachment accessories.....	X	
<u>Type II</u>		
Coating tacky, brittle, or flaky.....	X	
Coating not continuous, or not adherent (not highly resistant to removal by gentle scraping with knife blade).....	X	
Hanger wire and suspension hook shank not entwined with at least 3-1/2 twists of wire.....	X	
Damage or defects, not elsewhere specified, affecting function or serviceability.....	X	
Damage or defects which do not affect function or serviceability.....		X
<u>Type III</u>		
Nonskid feature missing or dislocated.....	X	
Apex of guard not curved.....	X	
Guards contaminated with transferable material.....	X	
Material not of natural color (exclusive of nonskid material).....		X
Any tears or sharp creases.....	X	
Edges not clean cut.....	X	
Hanger slot missing or dislocated.....	X	
Guard buckles when placed on type II clothes hanger.....	X	

*Not applicable if single-piece construction is used for shoulder-bar (see 3.1.2.1).

RR-B-1102D

4.3 Examination of preparation for delivery. An examination shall be conducted to determine whether the packing and marking comply with the requirements of section 5. Defects shall be scored as specified in table II. Sampling shall be in accordance with MIL-STD-105. The sample unit shall be one container fully prepared for delivery. The lot shall be the number of containers offered for inspection at one time. The inspection level shall be S-2 with an AQL of 4.0 expressed in terms of percent defective.

TABLE II. Examination of preparation for delivery

Examine	Defects
Containers	Not as specified.
Contents	Not as specified.
Markings	Omitted; incorrect; illegible; improper size, location, sequence or method of application.
Materials	Component missing or damaged.
Workmanship	Bulging or distortion of containers.

4.3.1 Examination of closure, waterproofing, and banding of containers. When containers are required to comply with PPP-B-636, examination for defects in closure, waterproofing, or banding shall be made in accordance with the appendix of that specification.

4.4 Tests.

4.4.1 Hangers.

4.4.1.1 Wood moisture. Compliance with the wood moisture content requirement of 3.1.1.1 shall be determined by the oven drying or electric moisture-meter method specified in MIL-STD-1363.

4.4.1.2 Performance. (a) Static loading, trouser bar: Hangers shall be suspended, in their normal mode, from a bar 1-1/2 inches (approx.) in diameter. A weight of 10 pounds for the type I hangers, and 2-1/2 pounds for the type II hangers, shall be evenly distributed over a 10 inch portion (5 inches on each side of center) of the trouser bars, of the respective hangers, for a period of 5 minutes. While loaded, the maximum deflection of the trouser bar(s) shall be measured to determine compliance with the applicable portion of 3.1.4.1. (b) Static loading, shoulder bar, suspension hook: Hangers shall be suspended as above. A weight of 20 pounds for type I hangers, and 4 pounds for type II hangers, shall be evenly distributed over the shoulder bar portions of the respective hangers, for a period of 5 minutes. During and following the loading period, all portions of the hangers shall be examined for compliance with the applicable portion of 3.1.4.1. (c) Dynamic loading, type I hangers only: Type I hangers shall be suspended from a height of approximately 5 feet (measured from lowest projection of hanger to floor), successively in each of the following modes:

- (i) Normal use mode (suspended from hook);
- (ii) Horizontal (plane of hanger parallel to floor);
- (iii) Vertical (trouser bar perpendicular to floor);

and dropped, 3 times in succession, in each mode, onto a tile or linoleum covered floor. Cushioned tile, cushioned linoleum, or carpeted floors shall not be acceptable. After each drop, the hanger being tested shall be examined to determine compliance with 3.1.4.2. If non-compliance is determined at some point prior to completion of all steps of the dynamic loading, the remainder of the test need not be conducted.

4.4.1.3 Rubbing test. A clean, white, cotton cloth shall be rubbed over the entire surface (exclusive of suspension hook) of finished type II hangers not less than ten (10) times. The cloth shall then be examined for compliance with the applicable requirements of 3.1.3.2.

4.4.1.4 Knife test (coating adherence). The sharpened edge of a sharp knife shall be placed in contact with the base metal of finished type II hangers, and then advanced along the length of the portion being examined. The tested portion shall then be examined for compliance with the applicable requirements of 3.1.3.2. Randomly selected, alternate portions of the hangers (e.g. horizontal bar, left shoulder bar, suspension hook, etc.) shall be examined on alternate units within the sample.

RR-H-1102B

4.4.1.5 Hot water resistance. One half of each of the finished, type II hangers to be examined shall be immersed in boiling water for ten (10) minutes. The hangers shall then be removed, allowed five (5) minutes recovery at room temperature ($68^{\circ} \pm 8^{\circ}\text{F}$), and then examined for compliance with 3.1.3.2.1.

4.4.1.6 Heat resistance. Finished type II hangers, tested in accordance with 4.4.1.5, shall be suspended in their normal use position and heated in an air oven at $300^{\circ} \pm 5^{\circ}\text{F}$ for five (5) hours. The finish shall be examined for compliance with 3.1.3.2.2 during the test. After the oven heating, the hangers shall be allowed to hang for one (1) hour at room temperature ($68^{\circ} \pm 8^{\circ}\text{F}$), and then examined for blistering, cracking or flaking, in compliance with 3.1.3.2.2.

4.4.2 Trouser guards.

4.4.2.1 Thickness. Trouser guards shall be measured for thickness, at two points on the guard (exclusive of nonkid application area), in accordance with TAPPI Standard T411 OS-68, to determine compliance with 3.2.3.2.

4.4.2.2 Material transfer. The top surface of the trouser guards shall be rubbed back and forth along their entire surface area, for three cycles, with a clean, white, hard-finished, cotton cloth (e.g. bed sheeting), at a normal pressure of about two pounds per square inch. The guard and the cloth shall then be examined for evidence of material transfer from one surface to the other in compliance with 3.2.1.

5. PREPARATION FOR DELIVERY

5.1 Packing. Packing for hangers and trouser guards shall be level A or C, as specified (see 6.2).

5.1.1 Level A.

5.1.1.1 Hangers. One hundred type I hanger or five hundred type II hangers, as specified (see 6.2), shall be neatly arranged and packed in a box conforming to PPP-B-636, class weather resistant. The box shall be closed, waterproofed, and banded in accordance with the appendix of the box specification.

5.1.1.2 Trouser guards. Five thousand trouser guards shall be nested and packed in a close-fitting box conforming to PPP-B-636, class weather resistant. The box shall be closed, waterproofed, and banded in accordance with the appendix of the box specification.

5.1.2 Level C. One hundred type I hangers, 500 type II hangers, or 5000 trouser guards, as specified (see 6.2), shall be packed in a manner to insure carrier acceptance and safe delivery at destination, at the lowest transportation rate for such supplies. Containers shall comply with the Uniform Freight or National Motor Freight classification, as applicable.

5.2 Marking.

5.2.1 Civil agencies. In addition to markings required by the contract or purchase order, the shipping containers shall be marked in accordance with Fed. Std. No. 123.

5.2.2 Military agencies. In addition to markings required by the contract or purchase order, containers shall be marked in accordance with MIL-STD-129.

6. NOTES

6.1 Intended use. Hangers covered by this specification are used to suspend garments. Trouser guards covered by this specification are used to prevent trousers from creasing or slipping off when folded over the horizontal bar of wire clothes hangers.

RR-H-1102D

6.2 Ordering data. Purchasers should select the preferred options permitted herein, and include the following information in procurement documents:

- (a) Title, number, and date of this specification.
- (b) Item and type, as applicable (see 1.2).
- (c) Responsibility for inspection requirements (see section 4).
- (d) Packing required (see 5.1).
- (e) Marking required (see 5.2).

6.3 Specification coverage. Federal specifications are not meant to include requirements for all varieties (all types, styles, etc.) of the commodity indicated by the title of the specification, or which may be commercially available. This specification is intended to provide requirements for the clothes hangers and trouser guards needed for general use by the Federal Government.

6.4 Trouser guards. This document replaces Interim Federal Specification UU-T-00670A, TROUSER GUARD, CLOTHES HANGER, (FSC 8135), dated June 14, 1968, as the governing Federal reference document for that commodity.

MILITARY CUSTODIANS:

Army - GL
Navy - SA
Air Force - 85

Preparing Activity:

GSA-FSS

User activity:

Army - GL

RR-H-1102D

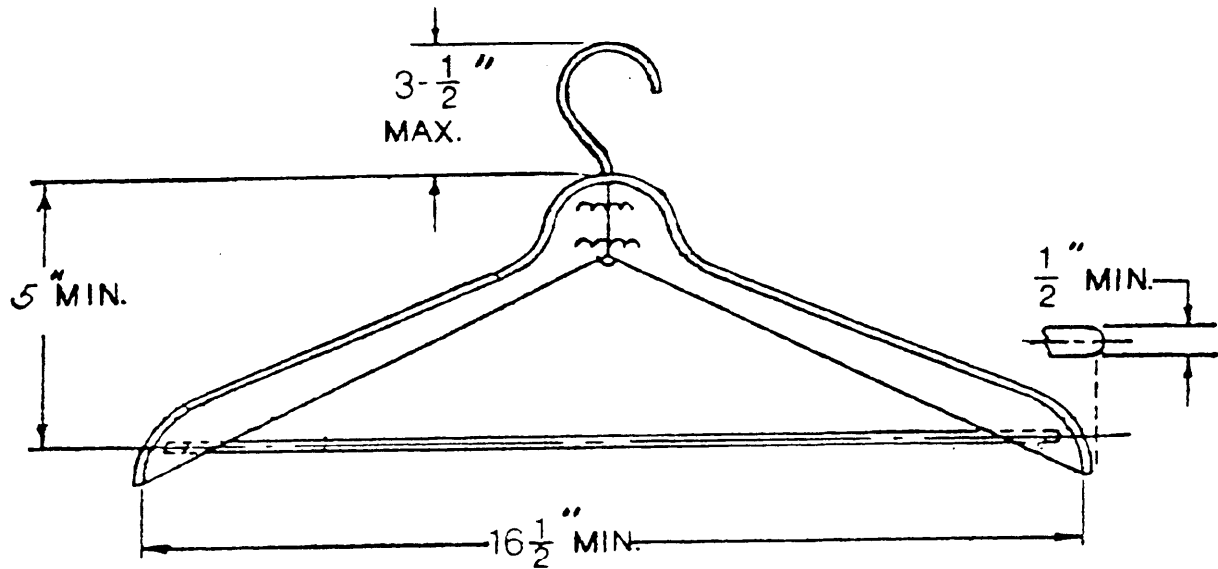

TYPE I COAT HANGER

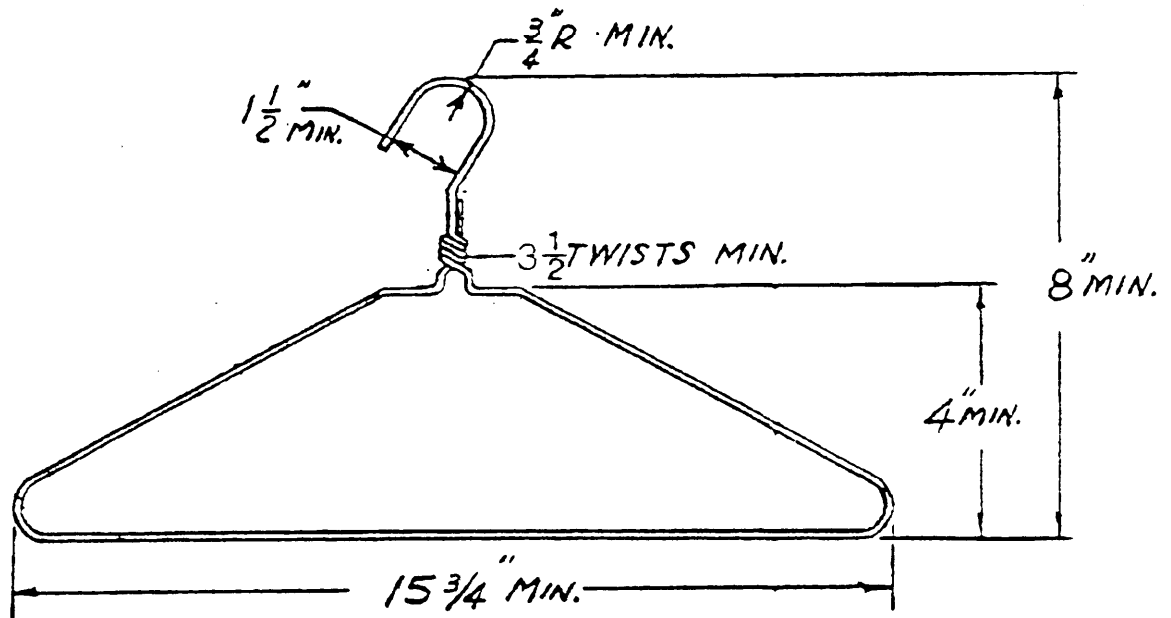

TYPE II COAT HANGER

FIGURE 1.

Orders for this publication are to be placed with General Services Administration, acting as an agent for the Superintendent of Documents. See Section 2 of this specification to obtain extra copies and other documents referenced herein. Price 35 cents each.