

PPP-B-1364C
~~August 30, 1973~~
 SUPERSEDING
 Fed. Spec. PPP-B-1364B
 September 23, 1968

FEDERAL SPECIFICATION

BOXES, SHIPPING, CORRUGATED FIBERBOARD, HIGH STRENGTH, WEATHER-RESISTANT, DOUBLE-WALL

This specification was approved by the Commissioner, Federal Supply Service, General Services Administration, for the use of all Federal agencies.

1. SCOPE AND CLASSIFICATION

1.1 Scope. This specification covers the requirements for high strength, weather-resistant, double-wall corrugated fiberboard shipping boxes.

1.2 Classification

1.2.1 Styles. The fiberboard boxes shall be furnished in the following styles as specified (see 6.2).

RSC	-	Regular slotted box (figure 1).
OSC	-	Overlap slotted box (figure 2).
TC	-	Telescope box, full or partial (figure 3).
HSC	-	Half slotted box with cover (figure 4).
HSCS	-	Half slotted box with flanged tube and cover (figure 5).
DBLCC	-	Double cover box (figure 6).

2. APPLICABLE DOCUMENTS

2.1 The following documents of the issue in effect on date of invitation for bids or request for proposal, form a part of this specification to the extent specified herein:

Federal Specifications:

MMM-A-250 - Adhesive, Water-Resistant (For Closure of Fiberboard Boxes.)
 PPP-B-638 - Boxes, Caps, Liners and Sleeves, Fiberboard, Knocked Down, Flat; Packing of.

Federal Standards:

Fed. Test Method Std. No. 101 - Preservation, Packaging and Packing Materials: Test Procedures.

(Activities outside the Federal Government may obtain copies of Federal Specifications, Standards, and Handbooks as outlined under General Information in the Index of Federal Specifications and Standards and at the prices indicated in the Index. The Index, which includes cumulative monthly supplements as issued, is for sale on a subscription basis by the Superintendent of Documents, U.S. Government Printing Office, Washington, DC 20402.

(Single copies of this specification and other Federal Specifications required by activities outside the Federal Government for bidding purposes are available without charge from Business Service Centers at the General Services Administration Regional Offices in Boston, New York, Washington, DC, Atlanta, Chicago, Kansas City, MO, Fort Worth, Denver, San Francisco, Los Angeles, and Seattle WA.

PPP-B-1364C

(Federal Government activities may obtain copies of Federal Specifications, Standards, and Handbooks and the Index of Federal Specifications and Standards from established distribution points in their agencies.)

Military Standards:

MIL-STD-105 - Sampling Procedures and Tables for Inspection by Attributes.
MIL-STD-109 - Quality Assurance Terms and Definitions.

(Copies of Military Specifications and Standards required by suppliers in connection with specific procurement functions should be obtained from the procuring activity or as directed by the contracting officer.)

2.2 Other publications. The following documents form a part of this specification to the extent specified herein. Unless a specific issue is identified, the issue in effect on date of invitation for bids or request for proposal shall apply.

Uniform Classification Committee, Agent:

Uniform Freight Classification

(Application for copies should be addressed to the Uniform Classification Committee, Room 1106, 222 South Riverside Plaza, Chicago, IL 60606.)

National Motor Freight Traffic Association, Incorporated, Agent:

National Motor Freight Classification

(Application for copies should be addressed to the American Trucking Associations, Inc., Tariff Order Section, 1616 P Street N.W., Washington, DC 20036.)

Technical Association of the Pulp and Paper Industry

T-402 Conditioning Paper and Paperboard for Testing
T-803 Puncture Test of Container Board

(Application for copies should be addressed to the Technical Association of the Pulp and Paper Industry, One Dunwoody Park, Atlanta, GA 30341.

(Technical society and technical association specifications and standards are generally available for reference from libraries. They are also distributed among technical groups and using Federal agencies.)

3. REQUIREMENTS

3.1 Materials

3.1.1 Fiberboard. The fiberboard shall consist of two corrugated members and three facings fabricated into a double-wall structural material.

3.1.1.1 Components. The facings and corrugated members of the double-wall fiberboard shall be combined in the following sequence:

- (a) An outer facing with a minimum total basis weight of 84 pounds per 1000 square feet (MSF) which shall be sized (wet strength treated).
- (b) One A or C flute member with a minimum total basis weight of 33 pounds per MSF which may be made of kraft, chestnut, bogus or semi-chemical corrugating medium and may be sized at the option of the manufacturer.
- (c) A middle facing with a minimum total basis weight of 69 pounds per MSF which may be sized at the option of the manufacturer.

(d) One B or C flute member with a minimum total basis weight of 33 pounds per MSF which may be made of kraft, chestnut, bogus or semi-chemical corrugating medium and may be sized at the option of the manufacturer.

(e) An outer facing identical to the outer facing described in 3.1.1(a).

3.1.1.2 Weight of components. The combined weight of the components shall not be less than 318 pounds per MSF.

3.1.1.3 Weight of fiberboard. The fiberboard shall weigh not more than 420 pounds per MSF when tested in accordance with 4.6.3.

3.1.1.4 Puncture resistance. The fiberboard shall have a minimum dry puncture test value of 950 inch-ounces per inch of tear and a minimum wet puncture test value of 300 inch-ounces per inch of tear when tested in accordance with 4.6.4. The specimens for the wet puncture test shall be submerged as specified in 4.6.2 prior to testing.

3.1.1.5 Short column crush. The short column crush shall be not less than 140 pounds per lineal inch when tested in accordance with 4.6.5.

3.1.1.6 Caliper. The thickness of the finished fiberboard shall not exceed 7/16 inch (with a plus 1/32 inch tolerance) when tested in accordance with 4.6.7.

3.1.2 Adhesives. The adhesives for combining the facings and corrugated members shall be water-resistant to the extent that the finished fiberboard shall comply with the ply separation requirements of 4.6.6. The adhesive used in forming the manufacturer's joints, where applicable, shall conform to MMM-A-250.

3.2 Box construction.

3.2.1 Dimensions. Boxes shall be furnished in the sizes specified (see 6.2). Dimensions shall be given in the sequence of length, width and depth. Unless otherwise specified, dimensions shall be the inside dimensions. A tolerance of plus or minus 3/16 inch shall be permitted.

3.2.2 Staples (manufacturer's joint). The staples used in fabricating boxes shall be wire conforming to either 3.2.2.1 or 3.2.2.2 except when the weight of the box and contents (gross weight) exceeds 140 pounds, only staples conforming to 3.2.2.2 shall be used.

3.2.2.1 Staples shall be made from flat wire and have a thickness of 0.037 inch with a tolerance of plus unlimited, minus 0.001 inch. The width shall be 0.088 inch with a tolerance of plus 0.001, minus 0.008 inch. The crown length shall be 3/4 + 1/16 inch.

3.2.2.2 Staples shall be made from arcuate wire or flat wire. The thickness of the arcuate wire shall be 0.020 inch with a tolerance of plus unlimited, minus 0.001 inch. The thickness of the flat wire shall be 0.023 inch with a tolerance of plus unlimited, minus 0.001 inch. The width of both types of wire shall be 0.103 inch with a tolerance of plus 0.001, minus 0.008 inch. The crown length shall be 7/16 + 1/16 inch.

3.2.3 Manufacturer's joint.

3.2.3.1 General. The manufacturer's joint is that seam of the box where the box blank is joined. The manufacturer's joint shall be lapped. At the option of the supplier, boxes with a perimeter exceeding 90 inches may be fabricated with two manufacturer's joints positioned at diagonally opposite corners of the box.

3.2.3.2 Styles RSC, OSC, HSC (body only), HSCS (body and flanged tube) and DBLCC (sleeve only). The manufacturer's joint shall be 1-7/8 inches wide. Prior to stapling, the corrugations in the 1-7/8 inch wide strip may be completely crushed on both the body and tab. The metal staples shall be placed horizontally or on a slant of 45° + 5° across the strip and shall be placed not more than 1-1/2 inches apart when staples described in 3.2.2.1 are used or more than 1 inch apart when staples described in 3.2.2.2 are used. The 1-1/2 or 1 inch measurement shall be from the lower tip of one staple to the top tip of the staple directly below as shown in figure 1. The first and last staple shall be placed 1/2 + 1/8 inch from the end of the manufacturer's joint. Alternatively, the manufacturer's joint may be 4 inches wide and securely glued over the entire area of contact with adhesive meeting the requirements of 3.1.2.

PPP-B-1364C

3.2.3.3 Styles TC, HSC (cover only), HSCS (cover only) and DBLCC (covers only). When set up, the flaps shall not completely overlap but shall be of sufficient length to allow them to be securely fastened to the adjoining walls with not less than five staples. Fastening along the free edges shall be not more than 4 inches apart.

3.2.3.3.1 Unless otherwise specified (see 6.2), the flaps on the body of style TC boxes shall positioned in either of the following combinations, at the option of the contractor:

- a. Flaps outside the side panels of the body and inside the end panels of the cover.
- b. Flaps outside the end panels of the body and inside the side panels of the cover.

Unless otherwise specified (see 6.2), covers for styles HSC, HSCS, and DBLCC shall have the flaps on the outside of the end panels.

3.2.4 Styles.

3.2.4.1 Regular slotted box (RSC). This box shall be in accordance with figure 1. The box shall be constructed of fiberboard (see 3.1.1) scored and slotted to form a body piece having four flaps for closing each of two opposite faces. The flaps along the longer edge of the box openings are the outer flaps and those along the shorter edge are the inner flaps. Flaps shall not project beyond the edge of the box. All flaps shall be of equal length, and the outer flaps shall meet when closed.

3.2.4.2 Overlap slotted container (OSC). This box shall be in accordance with figure 2. The box shall be constructed of fiberboard (see 3.1.1), scored, and slotted to form a body piece having four flaps for closing each of two opposite faces. When closed, the inner flaps shall not overlap and the outer flaps shall overlap the distance specified in the solicitation for offers (see 6.2). Inner flaps shall be the same length as the outer flaps, except where the relation of width to length would cause the inner flaps to overlap, in which case the inner flaps shall be cut so that, when in a closed position, they will meet.

3.2.4.3 Full or partial telescope box (TC). This box shall be in accordance with figure 3. The box shall consist of a body and a cover, each constructed of one piece of slotted and scored fiberboard (see 3.1.1). The inside depth of the cover shall either be the overall depth of the body, or the depth specified in the solicitation for offers (see 6.2). Setup of the boxes shall be in accordance with 3.2.3.3, 3.2.3.3.1, and 3.2.4.7.

3.2.4.4 Half-slotted box with cover (HSC). This box shall be in accordance with figure 4. The box shall be constructed of two pieces of fiberboard (see 3.1.1). The body of the box shall be scored and slotted to form a body piece having four flaps for closing one face. The opposite face is open the full length and width of the box. The flaps on the one face shall be as specified in 3.2.4.1. The cover shall be not less than four inches in depth and shall be assembled in accordance with 3.2.3.3, 3.2.3.3.1, and 3.2.4.7.

3.2.4.5 Half-slotted box with flanged tube and cover (HSCS). This box shall be constructed in accordance with figure 5. The box shall be constructed of fiberboard (see 3.1.1), scored and slotted to form a body piece having four flaps as specified in 3.2.4.1 for closing one face; the opposite face shall be open the full length and width of the box. The flanged tube shall fit snugly over the body and its flaps shall be at least six inches long. When folded the short flaps shall form the inner flaps. The cover shall fit snugly over the flanged tube and have a flap depth of at least six inches. The cover shall be assembled in accordance with 3.2.3.3, 3.2.3.3.1, and 3.2.4.7.

PPP-B-1364C

3.2.4.6 Double cover box (DBLCC). This box shall be constructed in accordance with figure 6. It shall consist of three pieces of fiberboard (see 3.1.1). The body shall be a stitched tube without flaps. The top and bottom covers shall be made in accordance with 3.2.3.3, 3.2.3.3.1 and 3.2.4.7. The covers shall afford a snug fit over the open faces of the body.

3.2.4.7 Covers. The covers for styles HSC, HSCS, and DBLCC boxes shall be made from a single piece of fiberboard and cut to form a cover having four flaps. Corrugation direction may be either parallel or perpendicular to the length dimension of the cover. Either configuration in any specified size shall meet all test requirements of the fiberboard. The flaps shall have a minimum width of four inches. Unless otherwise specified, covers being prepared for delivery shall not be stapled, but shall be scored and slotted ready for assembly.

3.3 Carrier's freight classification. The boxes shall comply with the provisions of the Uniform Freight Classification and the National Motor Freight Classification when they are to be used as containers for commodities covered therein and shipped via carrier to which either of these classifications apply.

3.3.1 Size limitations. The sum of the inside length, width and depth shall not exceed 120 inches.

3.3.2 Weight limitations. The gross weight shall not exceed 140 pounds except when the manufacturer's joint is stapled with staples conforming to 3.2.2.2, the gross weight may be increased to a maximum of 200 pounds.

3.3.3 Boxmaker's certification. Each box shall bear the applicable certificate of the boxmaker in compliance with the requirements of carrier's freight classification rules. When special package permits are obtained the box shall bear the package number and permit number in lieu of the boxmaker's certificate. The certificate may be located on the box wherever it is customarily placed, however, the preferred location is on the bottom panel.

3.4 Certification. Each container shall be marked by the manufacturer certifying that the box meets the requirements of this specification. This certification shall be located near the boxmaker's certificate.

3.5 Printing. Unless otherwise specified (see 6.2), each box except style HSCS, shall have the cube of the box to the nearest 0.1 cubic foot, based on the outside dimensions, printed on the box in 1/2 inch boldface print. The data shall be located in a corner of one side panel so that it will be visible when the box is assembled. When additional data is required, it shall be as specified (see 6.2).

3.6 Workmanship. The boxes shall be free from imperfections which may affect their utility. All dimensions of the boxmaker's blank shall be accurately cut, scored, and slotted so that the assembled box parts fit closely without undue binding. No flap shall project beyond the edge of the box when the box is set up and closed.

4. QUALITY ASSURANCE PROVISIONS

4.1 Responsibility for inspection. Unless otherwise specified in the contract or purchase order, the supplier is responsible for the performance of all inspection requirements as specified herein. Except as otherwise specified in the contract or order, the supplier may use his own or any other facilities suitable for the performance of the inspection requirements specified herein, unless disapproved by the Government. The Government reserves the right to perform any of the inspections set forth in the specification where such inspections are deemed necessary to assure that supplies and services conform to the prescribed requirements.

4.1.1 Definitions. MIL-STD-109 shall apply for definitions of inspection terms used herein.

PPP-B-1364C

4.1.2 Preproduction sample inspection. Preproduction sample inspection is not applicable to this specification unless otherwise required by the contract or order.

4.2 Inspection of materials and components. In accordance with 4.1, the supplier is responsible for insuring that materials and components used were manufactured, tested, and inspected in accordance with the requirements of referenced subsidiary specifications and standards to the extent specified, or if none, in accordance with this specification. In the event of conflict, this specification shall govern.

4.3 Classification of tests. The inspection and testing of the boxes shall be classified as acceptance tests and shall consist of all tests specified in 4.5 and 4.6.

4.4 Sampling for inspection and acceptance. Sampling for inspection and acceptance shall be performed in accordance with the provisions set forth in MIL-STD-105, except where otherwise indicated. For purposes of sampling, an inspection lot for examination and tests shall consist of all material of the same style submitted for delivery at one time. When multiple sizes of any one style are specified, the inspection lot may consist of all sizes presented at one time, in which case sampling shall be in proportion or ratio to the respective sizes in the lot. The acceptable quality level (AQL) shall be applicable to the entire lot regardless of defects as they may occur in any one or more sizes of box.

4.5 Inspection of the end item.

4.5.1 Examination of the end item. Examination of the end item shall be in accordance with the classification of defects, inspection levels, and AQL's set forth in the following. The lot size, for purpose of determining the sample size in accordance with MIL-STD-105, shall be expressed in units of boxes for examinations in 4.5.1.1 and 4.5.1.2. For examination in 4.5.1.3, the lot size shall be expressed in units of shipping containers.

4.5.1.1 Examination of the end item for defects in material, construction, appearance, and workmanship. The sample unit for this examination shall be the one completely fabricated box, knocked-down, partly assembled, or completely assembled, as applicable with covers, flanged tubes, and bodies, when required.

Examine	Defects
Material	Any component or material not of the style required. Any component missing or malformed. Weight of any component less than specified.
Construction and appearance	Any detail or feature of fabrication or construction not as specified and shown in drawings; flaps not regular slotted, overlapped, and crushed as applicable; or member or members not crushed where specified.
Fiberboard	Torn, split, or punctured; scuff extending through 1 ply; slight scuff covering an area greater than 3 square inches; ply separation in excess of 1/4 inch from the edge of the material. Style HSC not 2-piece construction (1 piece each top and bottom face and sides.) Style HSCS and DBLCC not 3-piece construction. NOTE: Unusually large boxes may be 2-piece construction with body joints on diagonally opposite edges. Any metal fastener cracked, rusted, malformed, not compensated for by additional fastener.

PPP-B-1364C

Examine	Defects
Workmanship	Less than the specified number of staples. Metal fastener not driven through fiberboard media (when required). Any protruding staple. Staples not clinched flush or below the surface of the fiberboard. Spacing of metal fasteners not as specified.
Scoring and score lines	Score not uniform and of insufficient depth to effect fold without distortion. Outer component ply on facing sufficiently split when scored to effect serviceability. Outer component ply or facing split completely through when folded in normal manner during assembly of box. Ends of the flap score line not crushed over the area specified.
General	Any construction or fabrication feature not in true alignment; assembled box and cover do not fit closely without binding. Staples not coated or treated as specified. Sleeves and interior pads, when applicable, not material and size specified. Not clean.
Marking	Boxmaker's certificate and additional (required) marking, missing, incomplete, incorrect, or illegible (see 3.3.3, 3.4 and 3.5).

4.5.1.2 Examination of the end item for dimensional defects. The sample unit for this examination shall be one completely fabricated box, knocked-down, partially assembled, or completely assembled, as applicable.

Examine	Defects
Metal fasteners	Less than size specified.
Box (overall inside dimensions)	Not within tolerances specified.
Flaps, lap joints	Less than length specified.

4.5.1.3 Examination of preparation for delivery. An examination shall be made to determine compliance with packing and marking requirements of section 5 and contract, as applicable. Examination shall be performed as specified in PPP-B-638.

4.5.1.4 Inspection levels and AQL's for examination. The inspection levels for the purpose of determining the sample size, and the AQL's expressed in defects per 100 units, shall be as follows:

Examination paragraph	Inspection level	AQL
4.5.1.1	I	6.5
4.5.1.2	S-3	4.0

PPP-B-1364C

4.5.2 Acceptance testing of the end item. Tests shall be performed for the characteristic requirements as indicated in table I, on samples randomly selected from each lot of boxes offered for acceptance. The sample unit shall be one box. Failure to meet unit or average requirements, as applicable, shall be cause for rejection of the lot. The lot size shall be expressed in units of boxes. The inspection level for determining the sample size, and the AQL's expressed as defects per 100 units, shall be as indicated in table I.

TABLE I. Instructions for testing (sample unit)

Characteristic	Spec. reference		Rqmts. appl. to		Number ¹ determina- tions per sample unit	Results reported as		Inspection level	AQL
	Require- ment	Test method	Indiv. unit	Lot average		Pass or fail ²	Numerically to nearest		
Atmospheric conditions	---	4.6.1	--	--	--	--	--	--	--
Weight of fiberboard	3.1.1.2	4.6.3	--	X	1	--	Pound	S-2	--
Puncture resistance	3.1.1.3	4.6.4	X	--	(4) Avg. of (2 on each side ¹)	--	Inch-oz.	S-2	2.5
Short column crush (edgewise)	3.1.1.4	4.6.5	X	--	3	--	Pounds/in.	S-2	2.5
Caliper	3.1.1.5	4.6.7	X	--	3	--	Inch	S-2	2.5
Ply separation	3.1.2	4.6.6	X	--	1	X	--	S-2	2.5

¹Test results shall include all values on which results are based.

²If failure is indicated, report description of failure and numerical point of failure.

4.6 Test procedures.

4.6.1 Controlled atmosphere. Specimens shall be conditioned and tests conducted in an atmosphere conforming to TAPPI T402.

4.6.2 Immersion procedure for wet puncture resistance and ply separation tests. Separate specimens, measuring 6 x 10 inches, shall be used for the wet puncture resistance and ply separation tests as applicable. The specimens shall be cut from undamaged, unscored and unprinted portions of the board. The specimens shall have the flute openings along the 10-inch dimension. The specimens shall be submerged in fresh aerated tap water at a temperature of 75° + 5°F with a pH value between 6.5 and 7.5. The top 10-inch edge shall be horizontal and 1-inch below the water surface. The specimen shall be supported vertically in such a manner that the water has free access to all surfaces and ply separation, if it occurs, will not be restricted. The specimen shall remain submerged for a period of 24 hours. After removal from the water, the specimen shall continue to be supported in a vertical position and allowed to drain until excess water has drained from the flutes and surfaces no longer glisten.

4.6.3 Basis weight determination. The basis weight of the fiberboard shall be determined in accordance with Fed. Test Method Std. No. 101, Method 5022.

4.6.4 Puncture resistance.

4.6.4.1 Dry. The dry puncture resistance of the fiberboard shall be determined in accordance with the puncture test specified in TAPPI T 803.

4.6.4.2 Wet. After immersion in accordance with 4.6.2, the wet puncture resistance shall be determined in accordance with the puncture test specified in TAPPI T 803.

PPP-B-1364C

4.6.5 Short column crush determination. The compressive resistance of the fiberboard shall be determined in accordance with Fed. Test Method Std. No. 101, Method 2033.

4.6.6 Ply separation. After immersion as specified in 4.6.2, the fiberboard shall be tested for proper adhesion of components as follows: If separation occur spontaneously and freely during soaking, the board fails to meet this requirement. Surface tension of water may cause the wet components of the fiberboard to cling together even though not properly bonded. Using pressure sufficient only to overcome the surface tension of the water, brush lightly with the ball of the thumb across the cut edges of the specimen. Repeat at several points on each of the four edges. In addition, a soaked specimen shall be laid on a table under atmospheric conditions of $75^{\circ} + 5^{\circ}\text{F}$ and $50 + 2$ percent relative humidity, with air circulating across the top surface of the specimen until the specimen fails or reaches equilibrium (minimum 24 hours). The fiberboard complies with the specification if separation of the components does not extend more than 1/4 inch from the edge of the specimen. Shearing of a component or separation of fibers shall not be considered as ply separation.

4.6.7 Caliper. The caliper of the fiberboard shall be determined in accordance with Fed. Test Method Std. No. 101, Method 1003.

5. PREPARATION FOR DELIVERY

5.1 Packing. Packing shall be level A, B, or C, as specified (see 6.2).

5.1.1 Level A. The boxes shall be packed knocked-down in accordance with PPP-B-638, as specified therein for overseas shipment.

5.1.2 Level B. The boxes shall be packed knocked-down in accordance with PPP-B-638, as specified therein for domestic shipment. When specified, (see 6.2) the boxes shall be shipped partly or completely assembled in accordance with the requirements of the contract or order.

5.1.3 Level C. The boxes shall be shipped either knocked-down, partly assembled, or completely assembled, as specified in the contract or order. Unless otherwise specified (see 6.2), the boxes shall be delivered bundled, boxed, or crated to afford adequate protection against damage during direct shipment from the supply source to the first receiving activity. The level, as a minimum, will conform to applicable carrier rules and regulations.

5.2 Marking. Marking shall conform to the marking requirements of PPP-B-638.

6. NOTES

6.1 Intended use. Boxes covered by this specification are intended for domestic and overseas consolidation shipments of general supplies, aircraft parts, and military equipment. Large boxes should be used as much as practicable to curtail or eliminate the use of high care weight wood or metal containers. This does not preclude the use of these boxes for non-consolidation loads where such use is feasible.

6.1.1 Typical use for these boxes is in the shipment of equipment, components, or general supplies from the contractor to supply depot or from depot to depot, or from depot to a zone of the interior or an overseas base.

6.2 Ordering data. Purchasers should select the preferred options permitted herein and include the following information in procurement documents:

- (a) Title, number, and date of this specification.
- (b) Style of box required (see 1.2).
- (c) Dimensions of box (see 3.2.1).
- (d) Position of flaps for style TC, HSC, HSCS and DBLCC boxes if different than specified (see 3.2.3.3.1).
- (e) The distance flaps shall overlap on style OSC boxes (see 3.2.4.2).
- (f) Depth of cover for style TC box (see 3.2.4.3).
- (g) Whether additional printing is required (see 3.5).
- (h) Selection of the applicable level of packing (see 5.1).
- (i) When style HSCS box shall not be placed on a pallet on skid prior to loading (see 30.1.5).
- (j) Type, size, style and material requirements for pallet or skid bases (see 30.1.6).

PPP-B-1364C

APPENDIX

10. SCOPE

10.1 This appendix covers the requirements for closing, sealing and reinforcing boxes fabricated in accordance with the requirements of this specification.

20. APPLICABLE DOCUMENTS

20.1 The following specification and standard, of the issues in effect on date of invitation for bids or request for proposal, form a part of this appendix to the extent specified herein.

Federal Specifications:

QQ-S-781	Strapping, Steel, Flat and Seals
PPP-S-760	Strapping, Nonmetallic (and connectors)

Federal Standard:

Fed. Std. No. 224	Closing, Sealing and Reinforcing of Fiberboard Shipping Boxes, General Methods For
-------------------	--

30. REQUIREMENTS

30.1 Closure.

30.1.1 Style RSC and OSC. Style RSC and OSC boxes shall be closed in accordance with Fed. Std. No. 224, Method 114.

30.1.2 Style TC. Style TC boxes shall be closed in accordance with Fed. Std. No. 224, Method 115 except when closing a partial telescope box with tape, the length of the tape strips shall be sufficient to allow 6 inches of tape to adhere to the cover and 6 inches of tape to adhere to the bottom panel of the box body.

30.1.3 Style HSC. Style HSC boxes shall be closed in accordance with Fed. Std. No. 224, Method 116.

30.1.4 Style DBLCC. Style DBLCC boxes shall be closed in accordance with Fed. Std. No. 224, Method 116 except that the two girthwise straps shall be applied so as to divide the box into equal units of length.

30.1.5 Style HSCS. Unless otherwise specified (see 6.2), prior to loading, a style HSCS box shall be placed on a pallet or wood skid. The pallet or skid shall be 1 inch longer and 1 inch wider than the box. The box shall be closed and secured to the pallet or skid by means of flat steel strapping conforming to QQ-S-781, type 1, class A or B, minimum size 5/8 x 0.018 inch; or nonmetallic strapping conforming to PPP-S-760 with a minimum breaking strength of 800 pounds. Two straps, positioned approximately 10 inches from the edges of the box, shall be placed lengthwise around the box. These straps shall be placed either on top or underneath the deckboards of the pallet or skid. Straps shall also be placed girthwise around the box within 6 inches of each end, and one additional girthwise strap shall be applied for every 24 inches of box length. The straps shall be placed under or through the pallet or skid in such a manner as not to be damaged during handling and shipping.

30.1.6 Pallet or skid bases. Unless otherwise specified (see 6.2), boxes shall be furnished without pallet or skid bases. When bases are required, the size and style, including material requirements, placements, and size of skids, shall be specified in the contract or order.

30.2 Sealing. Fiberboard boxes conforming to this specification shall be sealed in accordance with Fed. Std. No. 224, Method 151.

30.3 Reinforcing. Fiberboard boxes conforming to this specification shall be reinforced in accordance with Fed. Std. No. 224, Method 101.

PPP-B-1364C

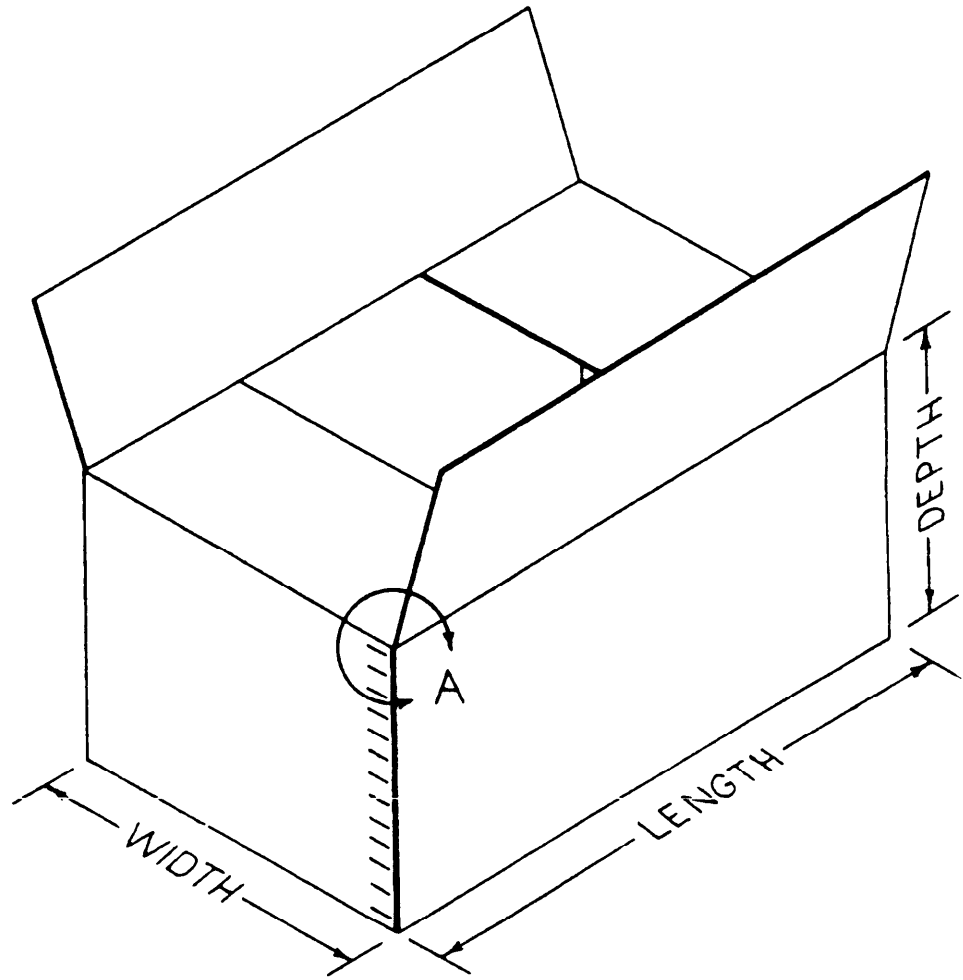
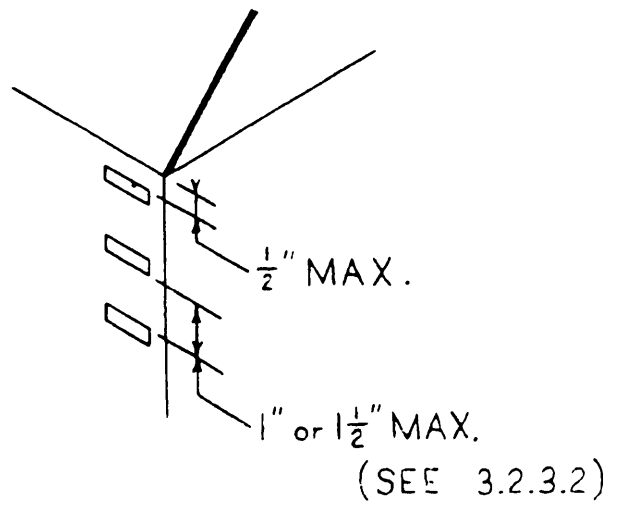

FIGURE 1. RSC - Regular slotted box.



DETAIL "A"

PPP-B-1364C

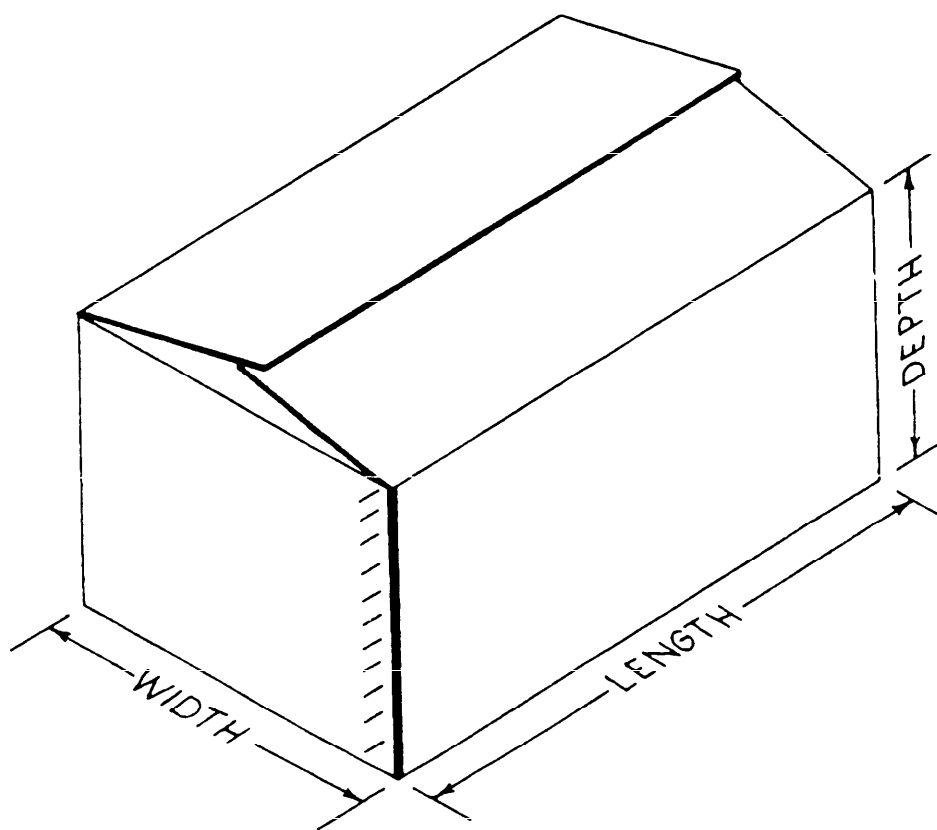
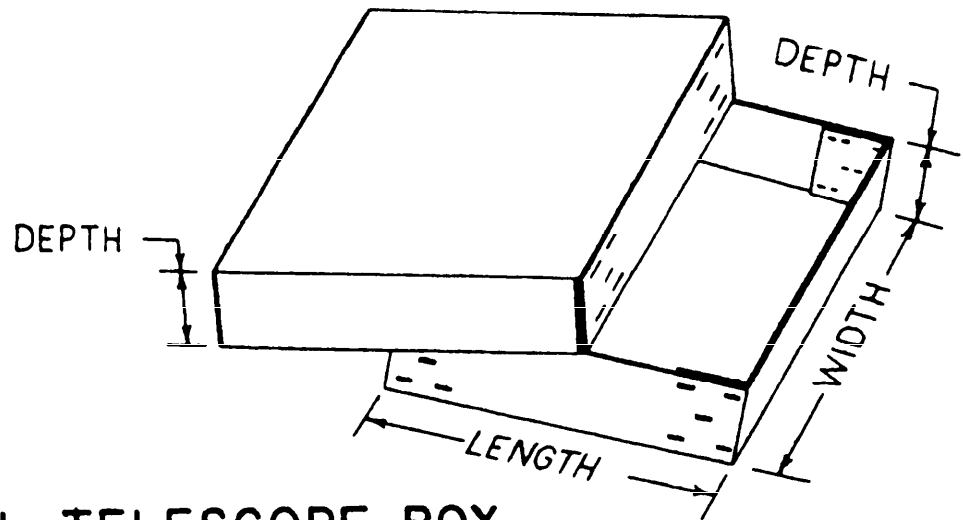
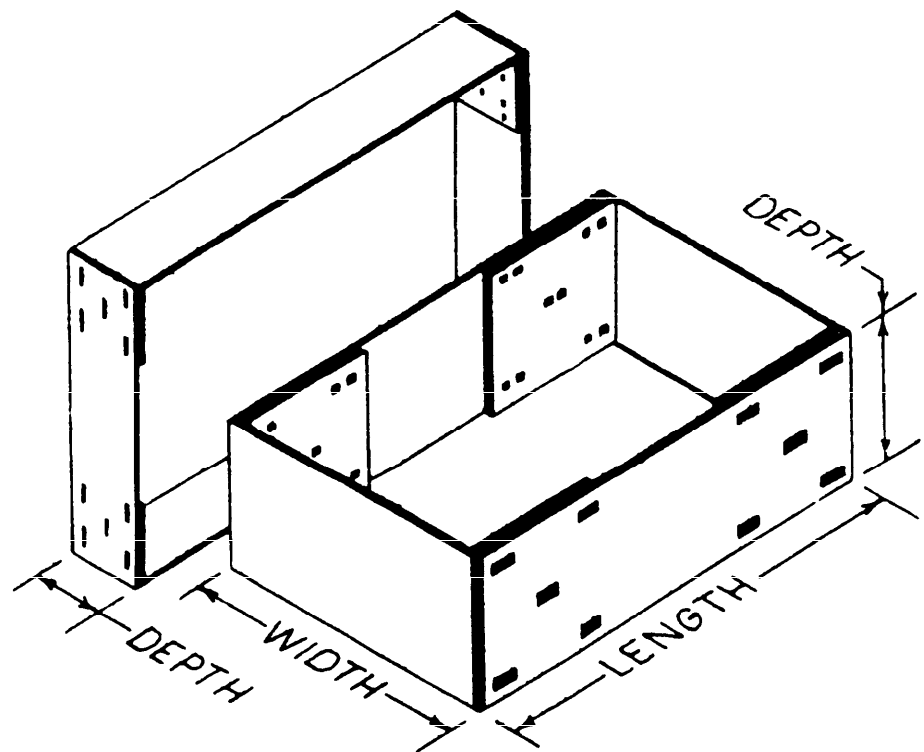

FIGURE 2. OSC - Overlap slotted box.

FPP-B-1364C



FULL TELESCOPE BOX



PARTIAL TELESCOPE BOX

FIGURE 3. TC - Telescope box, full or partial.

FPP-B-1364C

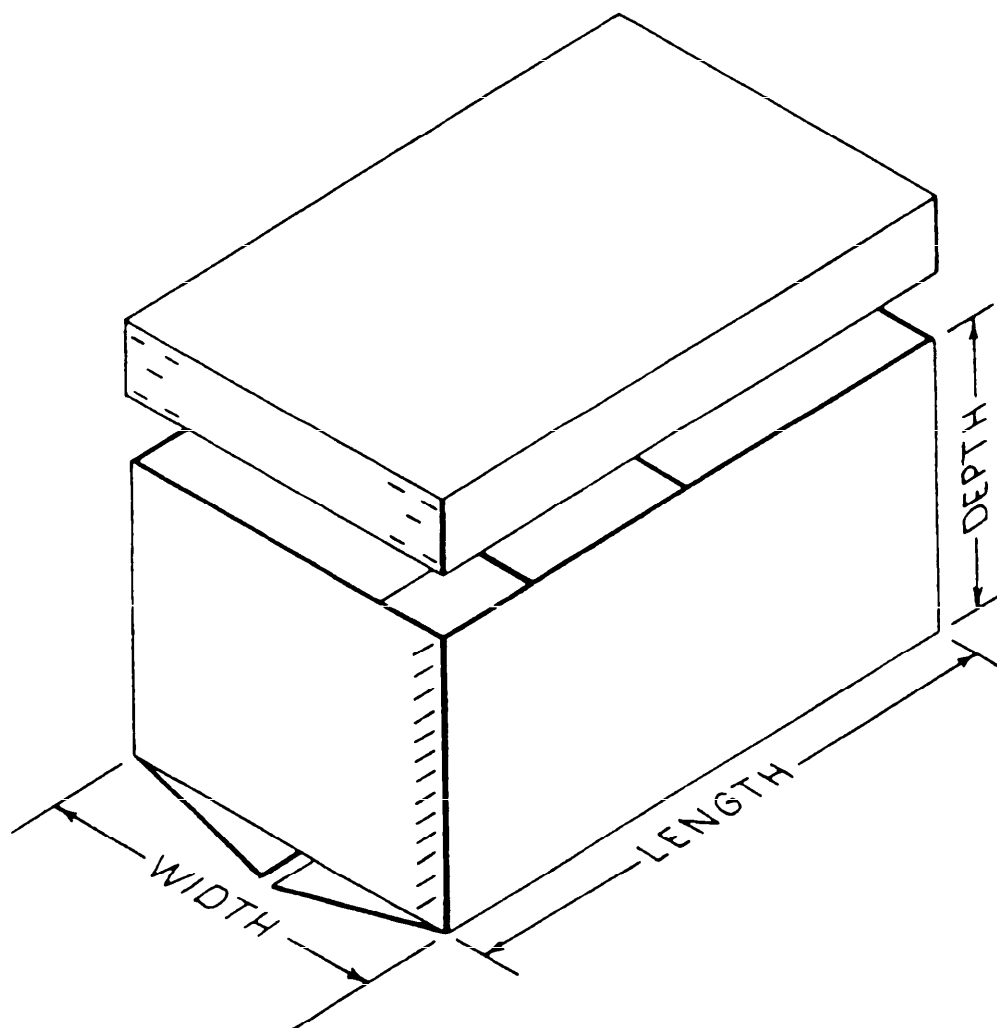

FIGURE 4. HSC - Half slotted box with cover.

PPP-B-1364C

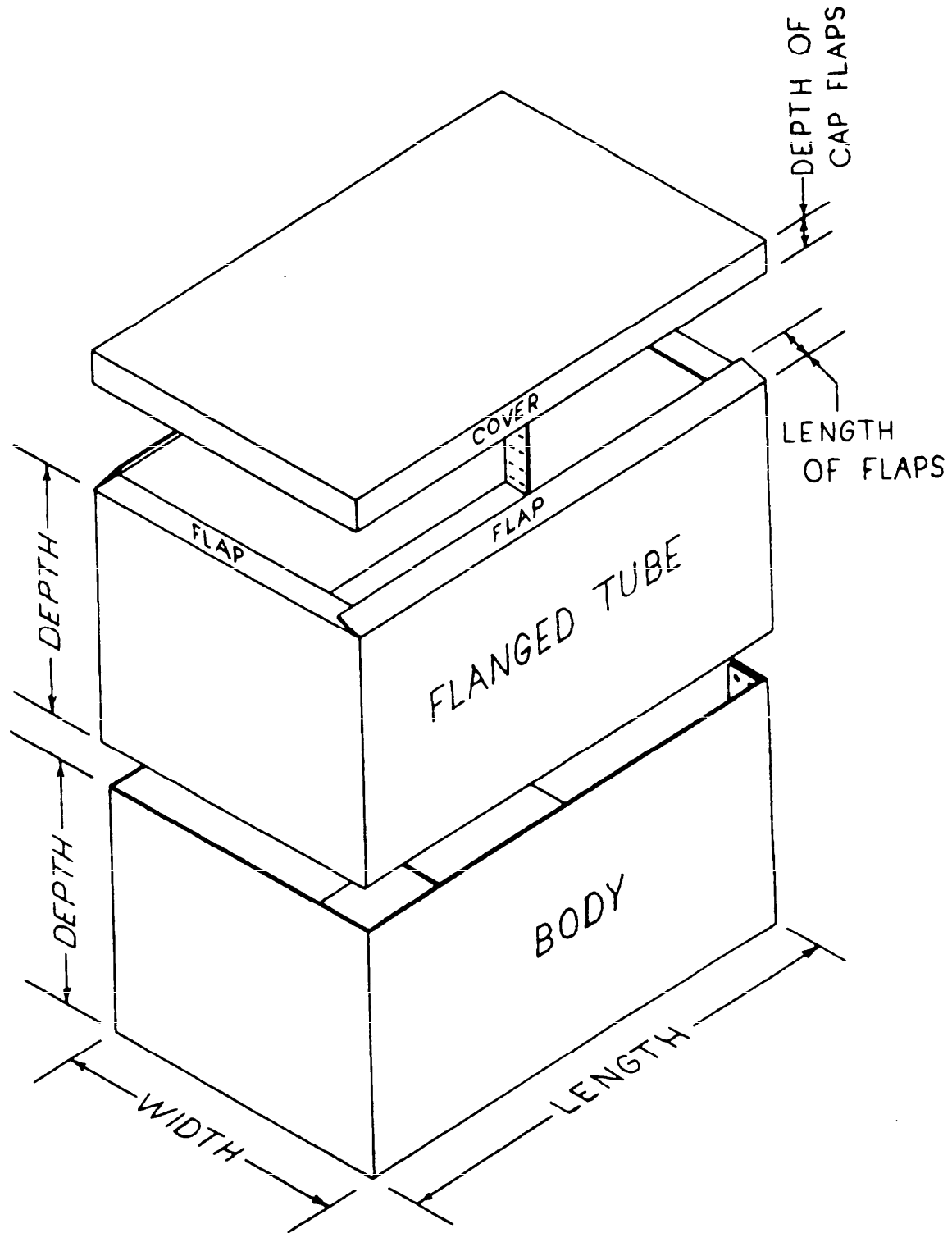

FIGURE 5. HSCS - Half slotted box with flanged tube and cover.

PPP-B-1364C

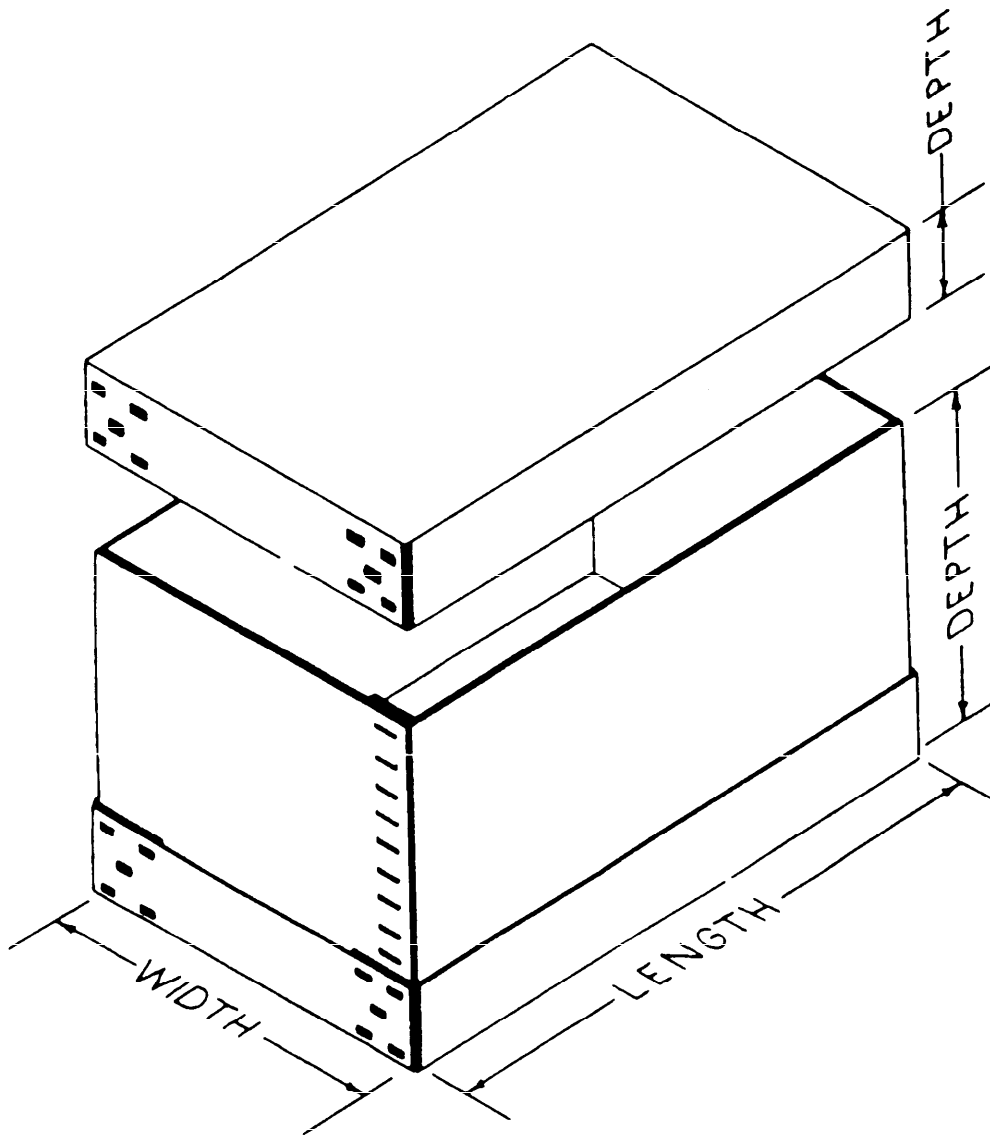

FIGURE 6. DBLCC - Double cover box.

Preparing activity:

Civil agency coordinating activities

GSA-FSS

GSA-FSS
USDA-AFS

U. S. GOVERNMENT PRINTING OFFICE : 1973 G - 544-600/1204

Orders for this publication are to be placed with General Services Administration, acting as an agent for the Superintendent of Documents. See section 2 of this specification to obtain extra copies and other documents referenced herein. Price 15 cents each.