

NN-P-71C
Int. Amendment - 2 (SA)
2 May 1977

FEDERAL SPECIFICATION
PALLETS, MATERIAL HANDLING WOOD
STRINGER CONSTRUCTION 2-WAY AND
4-WAY (PARTIAL)

This interim amendment was developed by the U. S. Naval Supply Systems Command, Washington, D. C. 20376 based on currently available technical information. It is recommended that Federal agencies use it in procurement and forward recommendation for changes to the preparing activity at the address shown above.

The General Services Administration was authorized the use of this interim amendment on a valid exception to Federal Specification NN-P-71, dated September 10, 1973.

PAGE 3

1.2, after Type VI and before Group I, add: "Type VII - Two-way, flush, assembled, nonreversible, single-use, 44 X 44 (see Figure 12)." and "Type VIII - Four Way, Partial, Wing, Nonreversible, Single Use, (see Figure 13)."

PAGE 4

2.1, under Federal Standards, add:

"FED. STD. No. 356 - Commercial Packaging of Supplies and Equipment."

PAGE 5

3.1, line 2, change "seven" to "eight"; line 3, after "four-way wing" insert: "and two-way flush"; line 6, change "five" to "six".

PAGE 6

3.3.1 change 4th sentence to read: "Types VI and VIII pallets shall be fabricated of Group III or IV woods;..."

3.3.1 (b) and 3.3.1 (e), line 1, delete "Type IV" both places and substitute "Types IV and VII".

3.3.1.1 change 1st sentence to read: "Unless otherwise specified (see 6.2), the moisture content of Class 1 components, except those for Types IV, VII and VIII pallets, shall be as follows at time of fabrication."

3.3.1.1 Line 8 change "Type VI and VII to "type VI, VII and VIII."

NN-P-71C
Int. Amendment - 2 (SA)

PAGE 7

3.3.1.1 Line 2 delete "Types IV and VII," and substitute "Types IV, VII and VIII."

3.4 line 7 change last sentence to read: "Figures 4 through 13 show detailed requirements for the various types of pallets covered herein."

PAGE 8

3.4.2.1.1, delete and substitute:

"3.4.2.1.1 Number and spacing of stringers. Types I and II pallets in the various widths, type IV pallets, type V, size 1 pallets, Type VII pallets and Type VIII pallets, shall have the number of stringers as specified below. Stringers shall be spaced uniformly, except that the second and fourth stringers on pallets 48 by 60 inches shall be spaced a minimum of 28 inches to a maximum of 30 inches between their inside surfaces, and located equidistant from the center stringer. Types III and V, size 2 pallets shall have four stringers with the two inside stringers located so that their outside edges are 8 inches apart and equidistant from the outside stringers.

Stringer Requirements (Types I, II, IV, V Size 1, Type VII and VIII)	
Width of Pallet (inches)	Number of Stringers
40	3
44	3
48	3
60	5

Types I, III, VI and VII pallets shall have the outside stringers flush with the ends of the deckboards. Types II, IV, and V pallets shall have the outside stringers located as shown in Figures 6 and 8. Type VIII pallet shall have stringers located as shown in Figures 13."

PAGE 9

Para. 3.4.2.1.2 Line 1: Delete "Types III, IV and V Pallets..." and substitute "Types III, IV, V and VIII Pallets..."

3.4.2.2, ~~Line 9~~, delete period after fourth sentence and add: ", except that for Type VII pallets the deckboards shall be not less than 3-1/2 inches wide."; line 12, place a comma after "3 inches" and delete: "and"; line 13, after "Figure 9", add: "and Type VI pallets shall be equally spaced as shown in Figure 12."; line 20, change complete sentence to read: "Type IV, VI, and VII pallets shall not have chamfers."

PAGE 10

3.5.1 line 9; delete the period after "wood" and add "not to exceed 1/8."

PAGE 13

4.5.1, Defects 107 and 108, delete 'Type IV' in two places and substitute "Types IV and VII".

PAGE 16

5.1, line 1, at beginning of first sentence insert: "Unless otherwise specified (see 6.2),".

5.2, 5.2.1, and 5.2.2, delete in their entirety and substitute:

"5.2 Packing. Packing for Class 1 and Class 2 pallets shall be Level A or Commercial, as specified (see 6.2).

5.2.1 Level A.

5.2.1.1 Class 1 (assembled). Uniform quantities of pallets shall be packed in bundles which do not exceed 41 inches in height. The bundles shall be secured with strapping which passes through the bottom pallet adjacent to or between the center stringer(s), encircles the bundle, and passes through the top pallet as on the bottom pallet. All bundles shall have a single, centrally located strap, except those of Type I, Size 4, and Type VI pallets which shall have two straps, one placed adjacent to each of the outside stringers. Strapping shall conform to QQ-S-781, Class 1, Type I or IV, Finish A or B, 3/4 X 0.020 inch minimum size.

5.2.1.2 Class 2 (unassembled). Twenty pallets shall be packed as shown in Figure 11. Nails for each bundle, when included, packed as specified in 5.1 shall be placed within a void space created among the stringer or the deckboards.

5.2.2 Commercial (Level C).

5.2.2.1 Class 1 (assembled). Unless otherwise specified, uniform quantities of pallets shall be secured in bundles which shall not exceed 55 inches in height. Bundles shall be strapped in a manner which will assure lowest rates and safe delivery in compliance with Uniform Freight Classification rules or National Motor Freight Classification rules.

5.2.2.2 Class 2 (unassembled). Unassembled pallets shall be packed as shown on Figure 11.

5.3 Marking.

5.3.1 Military packaging. Marking for Level A shall be in accordance with MIL-STD-129.

5.3.2 Commercial. Marking for military agencies shall be in accordance with FED. STD. No. 356. Marking for civil agencies shall be in accordance with FED. STD. No. 123."

6.1, add the following sentence: "Type VII pallets are intended to be used only for container stuffing operations."

NV-P-71C

Int. Amendment - 2 (SA)

PAGE 17

6.2, Item (f), delete and substitute:

"(f) If nails are not to be supplied with bundled unassembled pallets (see 5.1)."

Add Items (g) and (h) as follows:

"(g) Degree of packing required (see 5.2).

(h) If commercial packed assembled pallets are not to be bundled (see 5.2.2.1)."

PAGE 24

Figure 7^r delete last sentence of title ("Also applies to Type IV pallets)" and substitute "(Also applies to types IV and VIII pallets)".

Add new Figures 12 and 13 as pages 29 and 30 respectively.

Place concluding information on new page 31.

Custodian:
Navy - SA

Preparing Activity:
Navy - SA
DOD Project 3990-N152

NH-P-71C
Int. Amendment - 2 (SA)

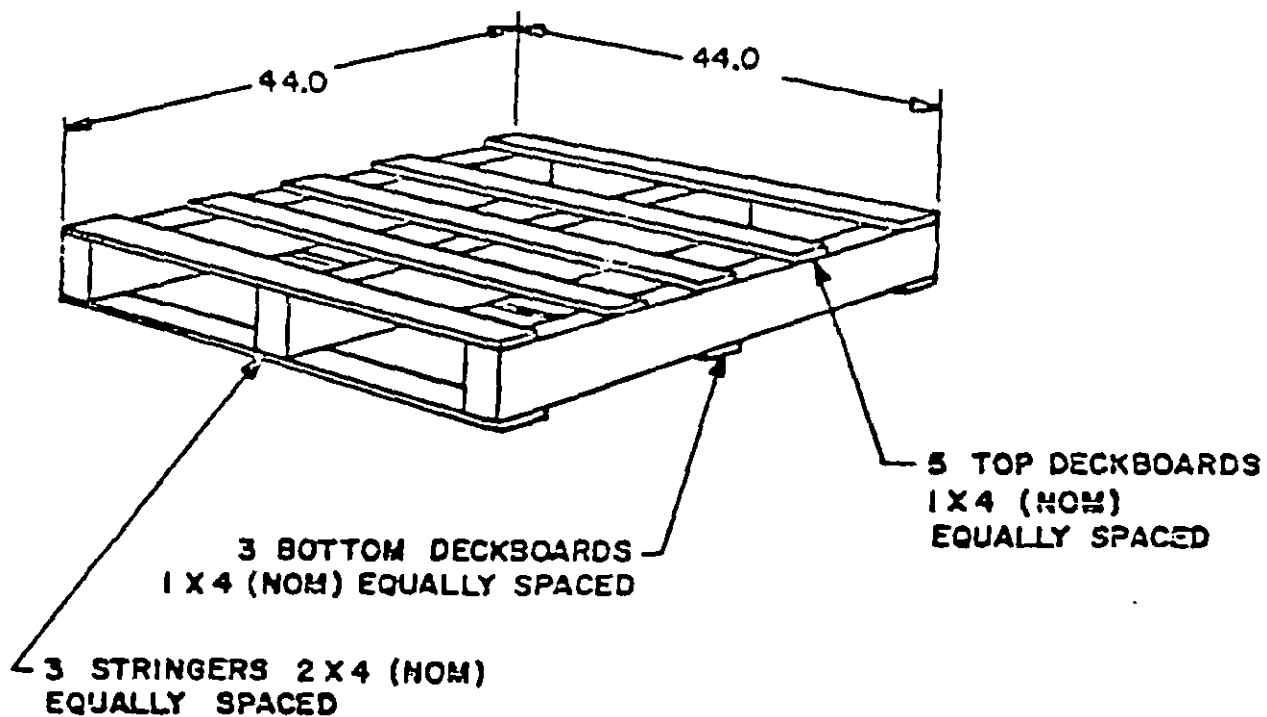

NOTE

ALL DIMENSIONS ARE IN INCHES

FIGURE 12. Type VII, two way flush pallet (dimensions shown for group I and II woods).

X-3191

NN-P-71C
Int. Amendment - 2 (SA)

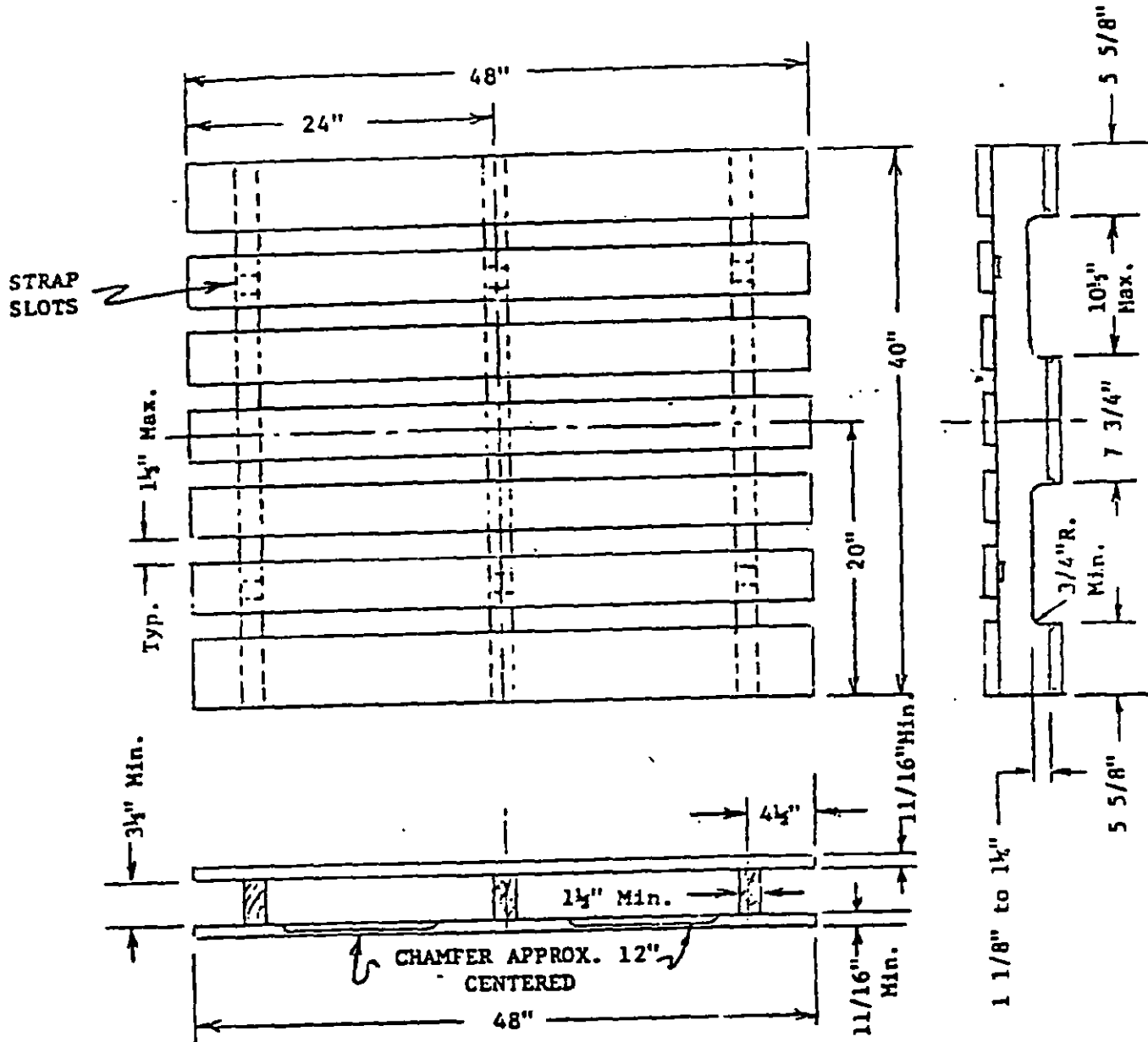

NOTE: SEE FIGURE 7 FOR DECK BOARD AND STRINGER DETAIL

FIGURE 13

TYPE VIII PALLET, 4-WAY PARTIAL, SIZE 2
GROUP III & IV, GRADE A OR B WOODS