

FF-L-2740  
October 12, 1989

FEDERAL SPECIFICATION

LOCKS, COMBINATION

This specification is approved by the Commissioner, Federal Supply Service, General Services Administration, for the use of all Federal agencies.

1. SCOPE AND CLASSIFICATION

1.1 Scope. This specification covers changeable, combination locks designed to be mounted on safes, security files, vault doors and similar items.

1.2 Classification. Combination locks shall be of the following styles, models, classes, types and sizes.

Style II - Manipulation, radiographic and thermal resistant.

Model HC - Hand change combination  
Model KC - Key change combination

Class TR - Top reading  
Class FR - Front reading

Type NT - Non-tube type  
Type T - Tube type

Size LD - Large dial  
Size SD - Small dial

2. APPLICABLE DOCUMENTS

2.1 Government Publications. The following documents, of the issues in effect on the date of invitation for bids or request for proposals, form a part of this specification to the extent specified herein.

Federal specifications.

PPP-B-566 - Boxes, Folding, Paperboard.  
PPP-B-601 - Boxes, Wood, Cleated-plywood.  
PPP-B-621 - Boxes, Wood, Nailed and Lock-corner.  
PPP-B-636 - Boxes, Shipping, Fiberboard

Federal Standards:

DISTRIBUTION STATEMENT A: Approved for public release;  
distribution is unlimited.

FSC 7110

FF-L-2740

Fed. Std. No. 123 - Marking for Domestic Shipment (Civilian Agencies).

(Activities outside the Federal Government may obtain copies of Federal Specifications, Standards and Handbooks as outlined under General Information in the Index of Federal Specifications and Standards and at the prices indicated in the Index. The Index, which includes cumulative monthly supplements as issued, is for sale on a subscription basis by the Superintendent of Documents, U.S. Government Printing Office, Washington, DC 20402.

(Single copies of this specification and other Federal specifications required by activities outside the Federal Government for bidding purposes are available without charge from Business Service Centers at the General Services Administration Regional Offices in Boston, New York, Washington, DC, Atlanta, Chicago, Kansas City, MO, Fort Worth, Denver, San Francisco, Los Angeles, and Seattle.

(Federal Government activities may obtain Federal Specifications, Standards and Handbooks and the Index of Federal Specifications and Standards from the established distribution points in their agencies.)

Military Specifications:

MIL-P-116 - Preservation, Methods of

Military Standards:

MIL-STD-100 - Engineering Drawing Practices  
MIL-STD-105 - Sampling Procedures and Tables for Inspection  
by Attributes  
MIL-STD-129 - Marking for Shipment and Storage  
MIL-STD-167 - Mechanical Vibrations of Shipboard Equipment  
MIL-STD-889 - Dissimilar Metals

(Copies of Military Specifications and Standards required by contractors in specification procurement functions should be obtained from the procuring activity or as directed by the contracting officer.)

2.2 Other Publications. The following documents form a part of this specification to the extent specified herein. Unless a specific issue is identified, the issue in effect on the date of invitation for bids or request for proposals, shall apply.

National Motor Freight Traffic Association, Inc., Agent:

National Motor Freight Classification.

(Application for copies should be addressed to the American Trucking Association, Inc., Traffic Department, 1616 P Street, NW, Washington, DC 20036.)

Underwriters' Laboratories, Inc. (UL) Publications:

ANSI/UL 768 - Standard for Combination Locks.

(Application for copies should be addressed to Underwriters' Laboratory, 333 Pfingsten Rd., Northbrook, IL 60062.)

Uniform Classification Committee, Agent:

Uniform Freight Classification.

(Application for copies should be addressed to the Uniform Classification Committee, Room 1106, 222 South Riverside Plaza, Chicago, IL 60606.)

2.3 Order of Precedence. In the event of a conflict between the text of this specification and the references cited herein, the text of this specification shall take precedence. Nothing in this specification, however, shall supersede applicable laws and regulations unless a specific exemption is obtained.

### 3. REQUIREMENTS

3.1 Qualification. The locks furnished under this specification shall be products which have been tested and have passed the qualification tests and inspections specified in section 4, and have been listed on or approved for listing on the applicable qualified products list (QPL). No changes may be made in the design or construction of listed products without written approval from the activity responsible for the qualification.

#### 3.1.1 Qualification suspension.

3.1.1.1 Development of entry techniques. The locks qualified under this specification will be continually tested by the Government during the term of qualification to determine whether the entry protection afforded by the locks can be improved. If, at any time, entry techniques are developed within the framework of the specification which affect a lock's integrity, it shall be removed from the QPL.

3.1.1.2 Change in specification requirements. This specification will be reviewed by the Government to determine whether specification requirements should or can, be changed to improve product quality. If, at any time, requirements are changed, and such changes affect the qualification status of a

FF-L-2740

qualified lock, it shall be removed from the QPL and the manufacturer will be required to modify the product to the extent necessary to comply with specification changes and have the product requalified.

3.2 Description. The lock shall be a dial operated, bolt type, combination lock and shall conform to the applicable requirements for Group 1R locks as specified in ANSI/UL 768. The lock shall have been tested for compliance with the ANSI/UL standard by a nationally recognized tested laboratory. The UL label shall not, in itself, constitute final approval of the lock.

3.3 Material.

3.3.1 Materials. Material used shall be free from defects that would adversely affect the performance or maintainability of individual components or of the overall assembly. Materials not specified herein shall be of the same quality used for the intended purpose in commercial practice.

3.3.2 Material deterioration and control. The lock shall be fabricated from compatible materials, inherently corrosion and deterioration resistant or treated to provide protection against corrosion.

3.3.3 Dissimilar metals. Dissimilar metals, as defined in MIL-STD-889, shall be plated or compatible to prevent operationally destructive corrosion.

3.4 Design.

3.4.1 Hand change locks. Hand change combination locks shall be designed to be readily combination changeable by hand without the use of special tools or keys. Changing the combination shall require a minimum amount of disassembly and reassembly. If the combination assembly is required to be removed for changing purposes, it shall be removable as a subassembly for accessibility and ease of servicing, outside the container. Removal of the lock back cover shall not require removal of more than two screws. The change assembly shall be designed to prevent loss of components or improper re-assembly. Parts which must be removed during combination changing shall be durable, reusable and not subject to damage or excessive wear. The change assembly retainer shall be a design easily removed without special tools. Lock design shall not include components which may be inadvertently detached or lost during combination changing. Lock design shall minimize the possibility of improper orientation of parts during reassembly. The combination setting shall be clearly identified. Simple, illustrated instructions shall be provided.

3.4.2 Key change combination locks. Key change combination locks shall be designed to be readily combination changeable by use of a key or special tool. Combination change shall not require removal or disassembly of the lock. Changing procedures shall require the lock to have the bolt extended during changing and shall ensure the operator must know the current operating combination prior to changing the combination.

3.4.3 Bolt lockout. The lock shall have a mechanical relock device that will block the bolt in the locked position if the lock cover plate is moved more than 0.10 inch (2.54 mm) at any point from its normal operating position.

3.4.4 Combinations. The lock combination shall be input by dialing. The combination for opening the lock shall not exceed four numbers. Each number shall be within the range of 0 and 99, inclusive. The lock shall have as a minimum 1,000,000 operational combinations as defined in 6.3.

3.4.5 Lock operation. The dial, spindle, bolt and all internal parts shall operate smoothly for the operating life of the lock, without the addition of anything but proper lubricants and without showing appreciable wear. Locks shall be tested for compliance with this requirement as specified in 4.5.2.1.

3.4.6 Lock bolt operation. All energy required for lock bolt operation shall be derived from mechanical operation of the lock dial by the operator.

3.4.7 Combination redial. Once the lock bolt has been extended to the locked position, it shall not be possible to reopen the lock without completely redialing the lock combination. For purposes of this requirement, the locked position means the bolt has been fully extended.

3.4.8 Case access. When the lock is mounted to the test fixture and locked, the assembled lock case shall not allow insertion of any device to permit visual inspection of the interior of the lock.

3.4.9 Wheel torque. When applicable, dynamic wheel pack torque for the lock shall be 16 to 20 inch-ounces (11.30 to 14.12 newton-centimeters) to facilitate ease of dialing. Torque shall remain within the specified torque range for the operating life of the lock, when tested in accordance with 4.5.2.1. Lock design may provide for adjustment of the torque to remain in the specified range. The dial and rotating internal parts shall not be free wheeling.

FF-L-2740

3.4.10 Temperature. The lock shall operate in a temperature range of -10 degrees F to 158 degrees F (-23.3 degrees C to 70 degrees C). At temperatures exceeding 158 degrees F (70 degrees C) +10, -0 degrees F, a thermal relock shall cause the lock to be deadbolted to prevent entry.

3.4.11 Humidity. The lock shall be designed to operate in a humidity range of 10 to 98 percent relative humidity for its operating life.

3.4.12 Vibration. Locks shall be subjected to Type I environmental vibration tests, as specified in 4.5.2.4. Operation and security performance and tolerance shall remain within standards.

### 3.5 Construction.

3.5.1 General. Locks supplied under this specification shall be interchangeable with existing UL approved Group 1R combination locks.

3.5.2 Dial and dial rings. Lock dials shall be top or front reading design, as specified, and shall be provided with suitable dial rings. The dial and dial ring design shall prevent casual observation of the combination during dialing. Logos or non-essential markings or features which may be related to the numeric setting shall not appear on the dial or other exposed, movable surfaces. When a graduated dial is provided, the dial shall be numbered from 0 to 90 in steps of 10 with each 5th division distinctively identified to facilitate reading. A dust cover shall be supplied to cover the dial and dial ring. The cover shall not interfere with normal dialing operation. When installed only the knob of the dial shall be available to grasp for rotation purposes. All other movable surfaces shall be shielded from touch.

3.5.3 Spindle. Unless otherwise specified, the lock shall be furnished with a spindle that can be cut to suit varying thicknesses of doors, drawers, and back plates not more than 3.5 inches in combined thickness. The spindle diameter shall not exceed 3/6 inch. The spindle or cam shall be so designed to permit the lock to be opened on a final setting of 0 when installed in right hand, left hand, vertical up or vertical down positions.

3.5.4 Tubes. When specified, the lock shall be provided with a tube that fits over the spindle to provide protection over the spindle and internal component parts from insulation and other unwanted material in the works. The tube shall be adjustable by cutting to bridge a combined thickness of door, insulation, back plate, etc., of not more than 3.5 inches.

3.5.5 Case and cover. The case and cover dimensions shall be as shown in figure 1. The cover shall be held in place by not more than two screws each

fitted with a lock washer, or other means of securing the screw. The lock shall allow attachment to the door or drawer by means of four, 0.250 inch 20 UNC-2a machine screws, located as shown in Figure 1. Unless otherwise specified machine screws shall be provided of sufficient length to extend 0.250 inch (6.35 mm) beyond the exterior of the lock case. The lock case mounting and spindle hole locations shall be as shown in Figure 1.

3.5.6 Lock bolt. The lock bolt's cross-section shall be not less than 0.312 by 1.00 inch (7.93 by 25.4 mm) with a minimum projection from the case of 0.437 inch (11.1 mm) in the locked position and flush to 0.062 inch (1.575 mm) in the unlocked position, and shall have not less than 0.312 inch (7.92 mm) throw.

3.5.7 Finish. All surfaces shall have a uniform finish of sufficient smoothness to accept markings required.

3.5.8 Workmanship. The locks shall be free of sharp edges, burrs, slivers and any defects affecting appearance, operation or serviceability.

### 3.6 Security.

3.6.1 Surreptitious entry. Locks shall be tested for resistance to surreptitious entry as specified in 4.5.2.2.4.

3.6.1.1 Manipulation. The lock shall resist opening through manipulation for a period of 20 man-hours.

3.6.1.2 Radiological analysis. The lock shall resist opening through radiological analysis for a period of 20 man-hours.

3.6.1.3 Emanation analysis. The lock shall not emit any sounds or other signals which may be used to surreptitiously open the lock within a period of 20 man-hours.

3.6.2 Covert entry. The lock shall resist covert entry for a period of 30 man-minutes, when tested as specified in 4.5.2.2.5.

3.6.3 Case and bolt strength. The lock case and bolt shall withstand the test specified in 4.5.2.3 without any fracture or bend of the bolt or case.

3.6.4 Government testing. The Government testing facility for the General Services Administration reserves the right of testing the combination lock in accordance with standards that are privileged to the Government.

3.7 Marking. Each lock shall be marked with the month and year of manufacture

FF-L-2740

on the dial, dial ring and lock case. Marking shall be embossed, impressed or engraved. Markings on the dial ring and dial shall be located so that they are not exposed when the lock is mounted. Marking on the lock case shall be visible on removal of the lock back cover.

3.8 Regulatory requirements. The offeror/contractor is encouraged to use recovered materials in accordance with Public Law 94-58C, as amended, to the maximum extent practicable.

#### 4. QUALITY ASSURANCE PROVISIONS

4.1 Responsibility for inspection. Except that testing for qualification shall be performed by an agency designated by the General Services Administration, the supplier is responsible for the performance of all inspection requirements as specified herein. Except as otherwise specified, the supplier may use his own or any other facilities suitable for the performance of the inspection requirements specified herein, unless disapproved by the Government. Inspection records of the examination and tests with itemized results shall be kept complete at the manufacturer's facility, available to the Government throughout the duration of the contract, or a minimum of two years, whichever is longer. The Government reserves the right to perform any of the inspections set forth in the specification where such inspections are deemed necessary to assure supplies and services conform to prescribed requirements.

4.1.1 Responsibility for compliance. All items must meet all requirements of sections 3 and 5. The inspections set forth in this specification shall become a part of the supplier's overall inspection system or quality program. The absence of any inspection requirements in the specification shall not relieve the contractor of the responsibility of assuring that all products or supplies submitted to the Government for acceptance comply with all requirements of the specification. Sampling in quality conformance does not authorize the submission of known defective material, either indicated or actual, nor does it commit the Government to acceptance of defective material.

4.1.1.2 Component and material inspection. In accordance with 4.1, the supplier is responsible for insuring that components and materials are insuring that components and materials are manufactured, tested and inspected in accordance with the requirements of referenced specifications and standards to the extent specified or, if none, in accordance with this specification.

4.2 Qualification testing and inspection. Qualification testing and inspection shall consist of the following tests and inspections. Failure to meet any one or more of these requirements shall provide reason to consider the product as



having failed to meet the requirement for qualification.

- (a) Operation test - 4.5.2.1
- (b) Security tests - 4.5.2.2
- (c) Case and bolt strength test - 4.5.2.3
- (d) Environmental vibration test - 4.5.2.4

4.3 Inspection and testing for acceptance. The Government reserves the right to inspect and test each lock, including all component parts thereof, delivered for acceptance under this specification after award of contract.

4.3.1 Inspection. Locks delivered for acceptance under contract or order shall be inspected as specified in 4.4. Any defect shall provide reason to reject the product. Rejected locks may be reworked to correct defects and they may be submitted for acceptance. Reworked locks shall be so indicated to the Government inspector.

4.3.2 Testing. Periodically, during the term of the contract, the Government inspector, at a time convenient to the Government, will select samples of the manufacturer's regular production and subject them to the tests in 4.5. This acceptance testing shall be performed by a Government agency specifically designated by the General Services Administration. Failure of the lock to meet any one or more of these tests shall provide reason to suspend acceptance of the manufacturer's product until the Government is satisfied that all defects have been corrected.

4.4 Quality conformance inspection. The quality conformance inspection shall include the examinations specified in 4.4.1, and preparation for delivery inspections specified in 4.4.2.

4.4.1 End item inspection. The locks shall be examined for defects in accordance with Table I. Sampling and inspection procedures shall be in accordance with MIL-STD-105. The unit of product shall be a complete lock. All combination locks offered for delivery at one time shall be considered a lot for the purpose of inspection. The inspection level shall be level II with an Acceptable Quality Level (AQL) of 2.5 percent defective.

4.4.3 Inspection of preparation for delivery. An inspection shall be made to determine that packaging, packing and marking comply with those specified in Section 5 of this specification. For examination of interior packaging, the sample unit shall be one shipping container fully prepared for delivery, selected at random just prior to the closing operations. Sampling shall be in accordance with MIL-STD-105. Defects of closure listed shall be examined on

FF-L-2740

shipping containers fully prepared for delivery. The lot size shall be the number of shipping containers in the end item inspection lot. The inspection level shall be S-2 with an AQL of 4.0 defects per hundred units.

Table I. Examination for defects.

---

Material is not resistant to corrosion and deterioration or treated to be resistant to corrosion and deterioration for the applicable storage and operating conditions.  
Dissimilar metals as defined in MIL-STD-889 are not treated or plated to prevent corrosion.  
Supplier does not have documentation available for identification of material, material finishes or treatment.  
Used, rebuilt or remanufactured component, pieces or parts incorporated in the locks.  
Design not as specified.  
Security of lock not as specified.  
Dimensions not as specified.  
Lock subassembly not as specified.  
Bolt lockout device not as specified.  
Lock torque not as specified.  
Dial ring not as specified.  
Dial not as specified.  
Spindle not as specified,  
Tube not as specified.  
Dust cover not as specified.  
Markings incorrect, missing or illegible.  
Finish not as specified.  
Instruction not furnished, or not as specified.  
Workmanship not as specified.

---

TABLE II. Classification of preparation for delivery defects.

---

Packaging	<p>Unit containers not sealed as specified.</p> <p>Instruction sheet not in unit container with lock as specified.</p> <p>Key not in unit container with lock as specified (Model KC only).</p> <p>Unit container not sealed with reinforced tape as specified.</p> <p>Sealed bag enclosing the unit container for level A preservation not Style 2 (transparent) as specified.</p> <p>Improper quantity of locks placed in intermediate container.</p> <p>Closure of intermediate container not as specified.</p>
Packing	<p>Shipping container not as specified.</p> <p>Shipping container weights exceed specified limitations.</p>
Marking	<p>Marking not in accordance with Fed. Std. 123 or MIL-STD-129, as specified.</p> <p>Marking not in accordance with the contract or order.</p> <p>Item description marked on unit container.</p> <p>Unit containers not marked or labeled with special instructions as specified.</p>

---

#### 4.5 Testing Procedures and tests.

##### 4.5.1 Qualification testing.

4.5.1.1 Testing agency. Qualification tests accomplished on products submitted under this specification for approval for inclusion on the applicable Qualified Products List (QPL) and any retesting that may be required shall be performed by a testing agency specifically designated or approved by the General Services Administration.

4.5.1.2 Testing costs. All testing costs entailed in determining the qualification of the supplier's product, including costs of retesting a qualified product if subsequently disqualified under 3.1.1.1 or 3.1.1.2, shall

FF-L-2740

be borne by the supplier, and shall be payable to the General Services Administration as directed by the Furniture Commodity Center, Federal Supply Service.

4.5.1.3 Test Procedures. The following procedures shall govern the testing of all products submitted for qualification under this specification.

- (a) Samples shall be submitted for qualification only after the supplier has obtained written authorization from the General Services Administration.
- (b) A qualification test may be discontinued at the Government's testing facility at any time the product fails to meet any one of the requirements set forth in this specification. The manufacturer may be permitted to make modifications on the sample during the testing phase where such modifications, in the judgement of the General Services Administration and the testing facility, are clearly in the interest of the Government.
- (c) In case of failure of the sample, consideration will be given to the request of the manufacturer for submission for retest only after it has been clearly shown that changes have been made in the product which the Government considers sufficient to warrant retest.
- (d) The manufacturer or his representative will not be permitted to observe the tests conducted on his product at the testing facility. However, when samples tested fail to comply with the requirements of this specification, the sample may be examined by the manufacturer or his representatives and full details of the failure may be made known to them in a manner which, for reasons of security will be in the best interest of the Government. Appropriate security clearances may be required prior to release of information relating to test procedures or results.

4.5.1.4 Test samples. Ten test samples of the style, model, class, type and size specified shall be submitted to a laboratory specified by the General Services Administration. In the event the samples are destroyed or damaged to such an extent during testing that testing cannot be completed, the Government reserves the right to require the manufacturer to furnish additional samples

necessary to complete the testing. Samples submitted for testing, shall be provided with an identification tag which references the specification, style, model, class, type and size.

4.5.1.5 Drawings and list of materials. The manufacturer shall furnish five complete sets of construction and assembly drawings and lists of materials with samples submitted for qualification. Drawing shall be prepared in accordance with MIL-STD-100. When the samples are tested and are approved for inclusion on the applicable QPL, three sets of the drawings and lists of materials shall be marked by the General Services Administration with the Government's approval. One set of drawings shall be returned to the manufacturer. Drawings will be used in inspections of products offered to the Government. All material so furnished by the manufacturer will be held in proprietary confidence.

4.5.1.5.1 Changes in construction or drawings. Once a product has been tested and approved for QPL, no subsequent change of any kind shall be made in its construction or in the construction drawings unless prior written authorization to make a change is obtained by the manufacturer from the Federal Supply Service, General Services Administration to meet requirement for qualification.

#### 4.5.2 Tests.

4.5.2.1 Operation test. The lock shall be subjected to 10,000 cycles of operation without replacement of any component. One cycle shall consist of dialing the combination at a speed not exceeding 48 revolutions per minute, retracting the bolt, throwing the bolt and scrambling the combination. Following the cycling, the lock shall be subjected to 50 combination changes including 3 open and close operational verifications after each change. The lock shall then be checked to verify that the dialing tolerance is still within the acceptable range specified by UL 768. The lock shall operate smoothly and the dial torque shall be in the range specified In 3.4.10. Any failure of the lock during test shall be cause for rejection.

#### 4.5.2.2 Security tests.

4.5.2.2.1 Test fixture. The security tests shall be conducted with the lock mounted to a test fixture. The fixture shall consist of a steel plate, 3/8 inch thick, mounted in an upright position. The plate shall be approximately 19 inches wide by 11 inches high. A second plate of equal thickness and dimensions shall be used for the base. The plates shall be drilled and tapped to allow mounting the lock using the screws specified in paragraph 3.5.5.

FF-L-2740

4.5.2.2.2 Break-in period. All tests shall be conducted before and after completion of the operation test in 4.5.2.1. Failure of the lock in either phase shall be cause for rejection.

4.5.2.2.3 Tools. Tools shall be limited to a maximum weight per test of 150 pounds.

4.5.2.2.4 Surreptitious entry. Attempts shall be made to unlock the lock through manipulation, radiological analysis and emanations analysis. Manipulation may include the use of automatic dialing devices. Manipulation and analysis may include the use of computer enhancement techniques for signals or emanations. The lock shall resist opening for the times specified in 3.6.1.

4.5.2.2.4.1 Wear test. The lock in the locked condition shall have the dial turned at 600 rpm for a period of not less than 8 hours, 4 hours in a clockwise and 4 hours in a counterclockwise direction. At the end of 8 hours, it shall not be possible to open the lock through surreptitious or covert techniques as specified in 4.5.2.2.4 and 4.5.2.2.5.

4.5.2.2.5 Covert entry. For the purpose of the covert entry test, access to the lock shall be limited to the dial and spindle. The lock will be presumed to be adequately protected against viewing or physical manipulation of the lock or lock case and against punching. The lock shall resist covert opening for the period specified in 3.6.2.

4.5.2.3 Case and bolt strength. Mount the lock on a test stand so that the bolt extends at least 0.10 inches beyond the edge of the stand, as shown in figure 2. Apply a force of 600 pounds to the bolt as shown in the figure. Examine the case and bolt for damage. Apply a force of 600 pounds to the bolt as shown in the figure 3. Any fracture or bending of the bolt or case shall be a failure.

4.5.2.4 Environmental vibration (type I). The type I environmental vibration test of MIL-STD-167 shall be conducted. Locks shall be checked for conformance to the operation, security and tolerance requirements. There shall be no movement or damage which affects normal operation or security.

## 5. PREPARATION FOR DELIVERY

5.1 Packaging. Locks shall be preserved in accordance with level A or C, as specified (see 6.2).

5.1.1 Level A.

5.1.1.1 Unit container. Installation and combination changing instructions and the combination change key (when applicable) shall be placed in an envelope. Each lock and envelope shall be packaged in accordance with sub-method of 1C2 of MIL-P-116. The snug fitting carton or box shall comply with PPP-B-566 or shall be the supplier's standard commercial carton or box. Closure of the carton or box shall be with reinforced tape. The sealed bag enclosing the carton or box shall be as specified for the submethod except that the bag shall be style 2.

5.1.1.2 Intermediate container. Ten locks, packaged as specified in 5.1.1.1, shall be placed in a close fitting fiberboard box conforming to PPP-B-636, class weather resistant. Box closure shall be in accordance with method V of the appendix to the box specification.

#### 5.1.2 Level C.

5.1.2.1 Unit container. Installation and combination changing instructions and the combination change key (when applicable) shall be placed in an envelope. Each lock and envelope be packaged in a close fitting fiberboard box. The box shall be sealed with reinforced tape.

5.1.2.2 Intermediate container. Ten locks, packaged as specified in 5.1.2.1, shall be placed in a close fitting fiberboard box conforming to PPP-B-636, class domestic. Box closure shall be in accordance with method I of the appendix to the box specification.

5.2 Packing. Packing shall be level A or C as specified (see 6.2).

5.2.1 Level A. Locks, packaged as specified in 5.1, shall be packed in a close fitting box conforming to PPP-B-601, overseas type, style optional or PPP-B-621, class 2, style optional. The gross weight of the box shall not exceed 200 pounds. Box closure and strapping shall be as specified in the applicable box specification or the appendix thereto, except that the strapping shall be flat and its finish shall be B.

5.2.2 Level C. Locks, packaged as specified in 5.1 shall be packed in a close fitting box conforming to PPP-B-636, class domestic, either single wall or double wall. The quantity per box shall not exceed the applicable weight limitation specified therein and the box closure shall be method 1 of the appendix thereto.

5.3 Marking. Marking shall be in accordance with Federal Standard No. 123 or MIL-STD-129, as specified.

FF-L-2740

5.3.1 Additional marking. Each unit container specified in 5.1 shall be marked with the following special instructions:

IMPORTANT

TO BE OPENED BY DESIGNATED

USER SECURITY PERSONNEL ONLY

The letters shall be 1/4 inch high minimum. Color to be red or black and shall be applied by marking the reinforced sealing tape (see 5.1) or by application of preprinted labels.

## 6. NOTES

6.1 Intended use. Combination locks covered by this specification are intended for use on safes, safe lockers, security containers, vault doors and similar items.

6.2 Ordering data. Purchasers shall specify the following:

- a. Title numbers and date of this specification
- b. Style, model, class, type and size required (see 1.2)
- c. Level of packaging and packing required.

## 6.3 Definitions.

6.3.1 Operational combinations. Operational combinations are combinations which may be set on the lock after excluding those settings which are prohibited by the manufacturer due the lock design. Operational combinations include those settings which are not recommended, but which may be used, such as 20-40-60.

6.3.2 Surreptitious entry. For the purpose of this specification, surreptitious entry means a method of entry, such as manipulation or radiological attack, which would not be detectable during normal use or during inspection by a qualified person.

6.3.3 Covert entry. For the purpose of this specification, covert entry means a method of entry which would leave evidence, but would not be detectable by a user during normal use, but would be detectable during inspection by a qualified person.

6.3.4 Entry. For the purpose of this specification, entry means retracting the bolt.

6.3.5 Normal use. For the purpose of this specification, normal use means dialing the combination, retracting the bolt, and extending the bolt.



FF-L-2740

6.4 Samples. All samples required for test purposes shall be furnished at no expense to the Government and the manufacturer shall pay all transportation to and from the point where the tests are performed. All tested samples shall become property of the Government but may be released to the manufacturer at the option of the Government. Upon request, the manufacturer shall furnish to the Government testing facility, a lock equal in respect to that of the qualified sample for use in inspection and test during the term of qualification. The lock shall be returned to the manufacturer upon removal of his product from the qualified products list.

6.5 Reference identification number. The reference identification number (RIN) system may be used for items covered by this specification. An example of the RIN is as follows:

FFL2740-2	A	D	N	S	
					L - Size LD - Large dial
					S - Size SD - Small dial
					N - Type NT - Non-tube type
					T - Type T - Tube type
					C - Class TR - Top reading dial
					D - Class FR - Front reading dial
					A - Model HC - Hand change combination
					B - Model KC - Key change combination
					2 - Style II

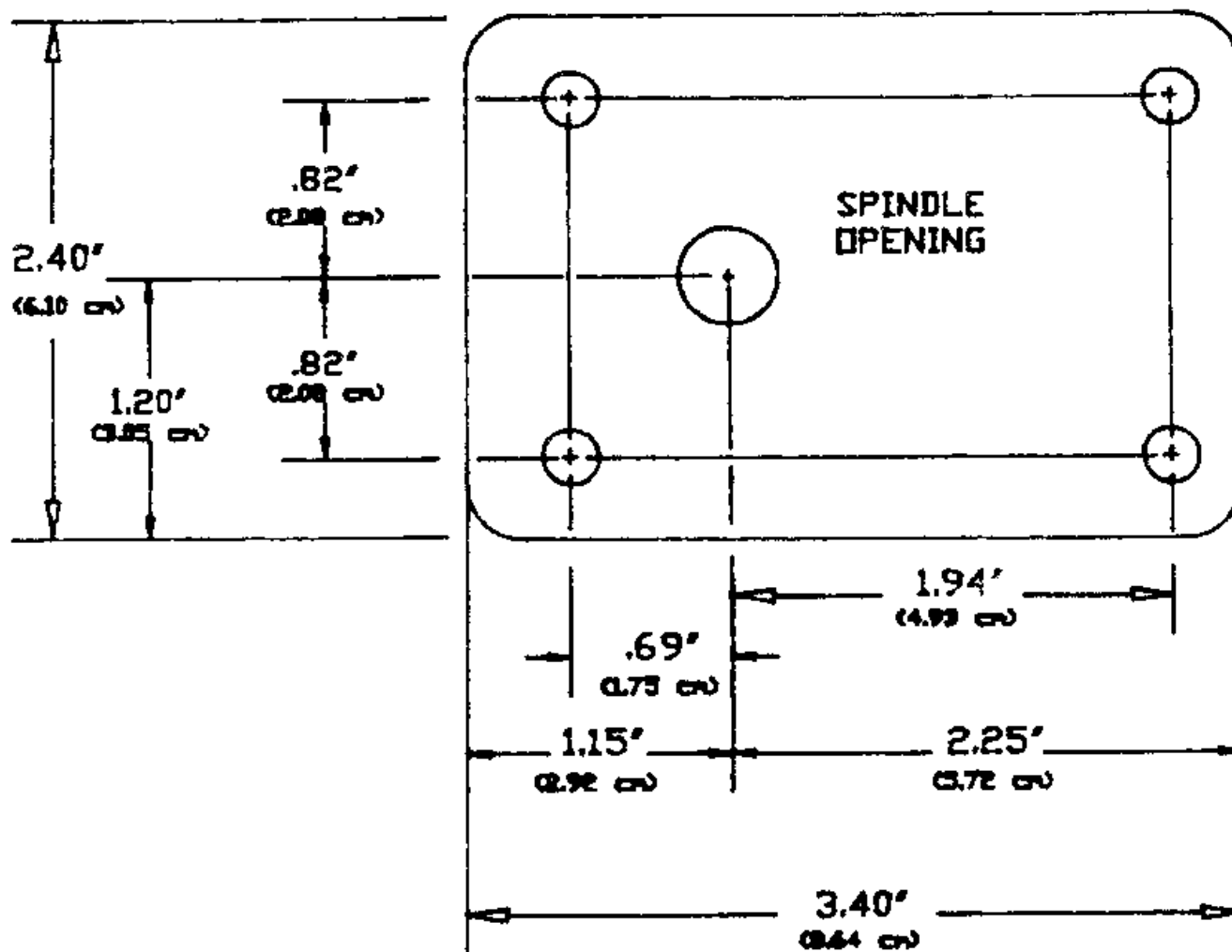

FIGURE 1  
Schematic arrangement of lock case holes.

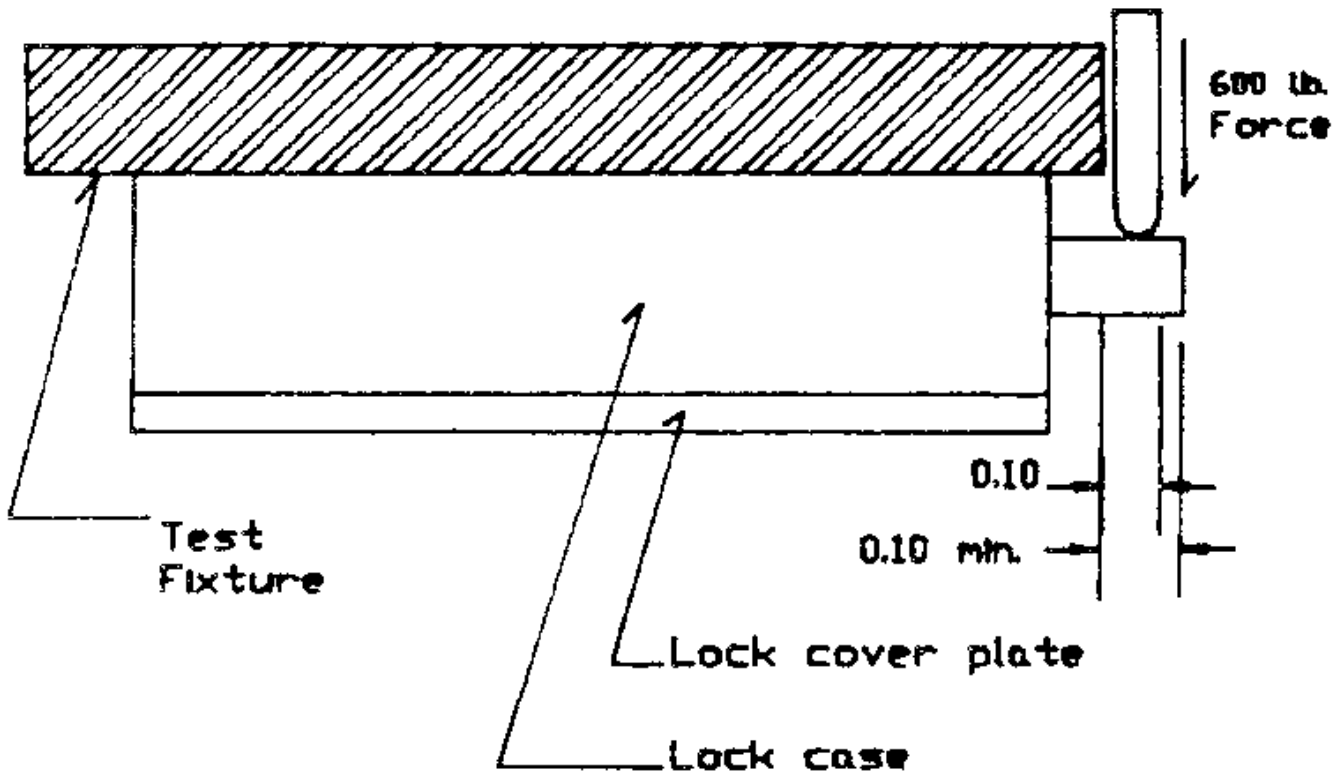

FIGURE 2 Case and bolt strength test.

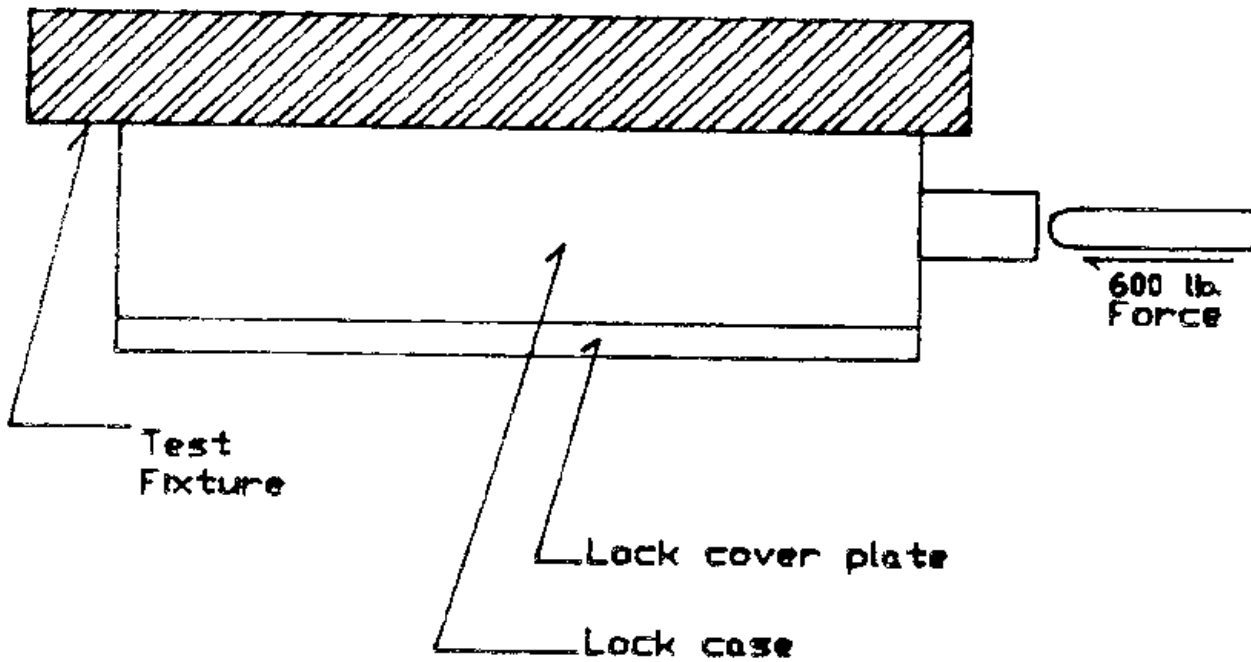

FIGURE 3 Bolt end pressure test

FF-L-2740  
INT. AMENDMENT-3  
December 3, 1994  
SUPERSEDING  
Int. Amendment-2  
February 25, 1994

INTERIM AMENDMENT  
TO  
FEDERAL SPECIFICATION  
LOCKS, COMBINATION

This interim amendment was developed by the General Services Administration, Federal Supply Service, National Furniture Center, Washington, DC 20406, based upon currently available technical information. It is recommended that Federal agencies use it in procurement and forward recommendations for changes to the preparing activity at the address shown above.

The General Services Administration has authorized the use of this interim amendment as a valid exception to FF-L-2740, dated October 12, 1989.

Page 1

At the bottom of the page, delete "FSC 7110" and substitute "FSC 5340".

Paragraph 1.1

Add a new sentence at the end of the paragraph, as follows: "The specification also addresses technical requirements for automatic deadbolt locks designed to be used in conjunction with surface mounted combination locks on strong room and secure area doors."

Paragraph 1.2

Line 2, delete "styles" and substitute "configurations".

DISTRIBUTION STATEMENT A: Approved for public release;  
distribution is unlimited.

FSC 5340

FF-L-2740

Add the following before Style II:

Configuration I - Combination lock

Delete "Style II - Manipulation, radiographic and thermal resistant."

Add the following after Size SD:

Configuration II - Pedestrian door combination deadbolt lock

Model KL - Key lock life safety feature

Model SL - Keyless life safety feature

Class DR - Drill resistant mounting plate

Class NDR - Non-drill resistant mounting plate

Class B - Basic, no exterior mounting plate

Strike #1 - Single or double door inswing mortise

Strike #2 - Single door outswing

Strike #3 - Single or double door inswing surface

Strike #9 - Double door outswing surface

Add a new paragraph as follows:

1.2.1 Reference Identification Number (RIN). A specification based Reference Identification Number to identify configurations, models, classes, types, sizes and strikes is addressed in paragraph 6.5 of this specification.

Page 3

Add the following to the end of paragraph 2.2.

National Fire Protection Association

NFPA 101 - Life Safety Code

(Application for copies should be addressed to the National Fire Protection Association, 1 Batterymarch Park, P.O. Box 9101, Quincy, MA 02269-9101.)

Page 4

Paragraph 3.2, line 5, delete "tested" and substitute "testing".

Page 5

Paragraph 3.4.6

Add the following new sentence: "The torque required to retract the bolt shall not exceed 50 inch-ounces (0.353 N-m)."

Page 6

Add new paragraphs:

3.4.13 Life safety feature. Pedestrian door combination deadbolt locks shall be designed with a life safety feature in the form of a bolt hold back feature meeting the requirements of NFPA 101. The life safety feature shall be designed to hold the deadbolt in a non-locked position when the deadbolt is retracted. The life safety feature must be able to prevent inadvertent or malicious engagement while the area being protected is occupied, and ensure a quick, safe exit in the case of an emergency. The life safety feature shall be of two different models. Model KL shall be equipped with a key lock. Model SL shall be equipped with a keyless device.

3.4.13.1 Key lock life safety feature. The bolt hold back feature on Model KL locks shall use a conventional key cylinder. Each Model KL lock shall be furnished with two keys.

3.4.14 Automatic deadbolt mechanism. The pedestrian door locks shall have a trip device that will, when the lock bolt is extended, automatically extend the deadbolt into the locked position upon release of the hold back feature and mechanism engagement of the strike.

3.4.15 Strikes. The pedestrian door lock shall have interlocking strikes to prevent jamming or spreading the door frame. The strikes shall be as shown in Figure 5. Each deadbolt shall be furnished with a strike as specified (see 6.5.2).

3.4.16 Drill resistant feature. When Class DR is specified, the pedestrian door lock shall be supplied with a drill resistant plate. The drill resistant

FF-L-2740

plate shall prevent penetration by drilling for a period of 20 minutes. The Class DR lock shall include an exterior mounting plate that is designed to sandwich the door and increase the strength of the lock mount. The mounting plate shall be designed for doors between 1-5/8" (41.3 mm) and 1-3/4" (44.4 mm) thick and shall be adjustable to doors within this range without modification or substitution of parts. The mounting plate shall be mounted to the exterior surface of the door, and the dial ring shall be affixed to it. The mounting plate and decorative stainless steel cover shall be maximum 5/8" (15.9 mm) thick, minimum 5-5/8" (142.9 mm) wide and 5" (127 mm) high, overall, with a stainless steel decorative cover. The height and width of the plate shall not vary by more than 1/8" (-3.2 mm) and in no case may the plate interfere with the door stop on the jamb.

3.4.17 Mounting plate. When Class NDR is specified, the pedestrian door lock shall be provided with a mounting plate (A36 steel or equivalent) that is designed to sandwich the door and increase the strength of the lock mount. The mounting plate shall be designed for doors between 1-5/8" (41.3 mm) and 1-3/4" (44.4 mm) thick and shall be adjustable to doors within this range without modification or substitution of parts. The plate shall be mounted to the exterior surface of the door, and the dial ring shall be mounted to it. The plate and decorative stainless steel cover shall be maximum 5/8" (15.9 mm) thick, minimum 5-5/8" (142.9 mm) wide and 5" (127 mm) high overall. The height and width of the mounting plate shall not vary by more than 1/8" (-3.2 mm) and in no case may the mounting plate interfere with the door stop on the jamb.

3.4.18 Escape feature. The bolt shall be able to be retracted from inside the area being secured, when the lock is locked and the deadbolt extended, without use of a key or other device. When so retracted, the bolt shall automatically be held in a retracted position when the door is open, and shall automatically extend into the locked position upon mechanism engagement of the strike.

Paragraph 3.5.2

Delete the sentence beginning, "When a graduated dial is provided...", and substitute the following:

"When a graduated dial is provided, the dial shall be numbered with distinct divisions to facilitate reading."

At the end of paragraph 3.5.2, add the following sentences:

"Size LD locks shall have a dial not less than 3" (76 mm) in diameter. Size SD shall have a dial less than 3" (76 mm) in diameter."

Page 7

Paragraph 3.5.6

Delete the paragraph and substitute:

3.5.6 Lock bolt. Unless otherwise specified, the lock bolt cross section shall be 0.310" +/- 0.005" by 0.995" +/- 0.005", -0.003" (7.87 mm +/- 0.13 mm by 25.27 mm + 0.13 mm, - 0.08 mm). The bolt throw shall be not less than 0.312" (7.92 mm). Any variations in the bolt dimensions shall be approved by the activity responsible for the lock qualification.

Add new paragraph.

3.5.6.1 Configuration II lock bolt. On the pedestrian door lock, the exposed portion of the deadbolt shall have hardened steel pin inserts. The cross section and configuration of the deadbolt on the pedestrian door lock shall be as required for the proper functioning of the lock.

Paragraph 3.6.4

Delete "Privileged" and substitute "privileged".

Page 8

Add new paragraph:

3.9 Instructions. Manufacturer's instructions, normally furnished in commercial practice, describing how to mount and operate the lock shall be



FF-L-2740

furnished with each lock. Instructions for pedestrian door locks shall cover the combination lock as well as the deadbolt. This requirement does not apply to locks shipped in bulk to container or vault door manufacturers.

Page 9

Paragraph 4.2

Add to the end of the paragraph, after item (d):

- (e) Operating temperature test - 4.5.2.5
- (f) Inspections - 4.6

Paragraph 4.4.3

Change paragraph number from 4.4.3 to 4.4.2.

Page 11

Table II

Add new sentence under Packaging defects.

Keys not in unit container with lock as specified (Model KL only).

Page 12

Paragraph 4.5.1.4, first line.

Delete "Ten test samples" and substitute "Twenty test samples".

Page 13

Paragraph 4.5.2.1

Delete "3.4.10" and substitute "3.4.9."

Add new paragraph:

4.5.2.1.1 Life safety feature operation test. The deadbolt and life safety feature of the pedestrian door lock shall be subjected to 10,000 cycles of

operation without replacement of any component. One cycle shall consist of:

- a. Bolt retraction (using interior bolt retraction device)
- b. Activate the life safety feature
- c. Deactivate the life safety feature
- d. Extend the deadbolt (door strike plate contact to depress the trip device)

Page 14

Delete paragraph 4.5.2.3, and add the following paragraphs:

4.5.2.3 Case and bolt strength. Locks shall be tested as specified in paragraphs 4.5.2.3.1 and 4.5.2.3.2.

4.5.2.3.1 Configuration I. Mount the lock on a test stand so that the bolt extends at least 0.10 inches (2.54 mm) beyond the edge of the stand, as shown in Figure 2. Apply a force of 600 pounds to the bolt as shown in the Figure. Examine the case and bolt for damage. Any fracture or bending of the bolt or case shall be a failure. Apply a force of 600 pounds as shown in Figure 3. Any fracture or bending of the bolt or case or movement of the bolt more than 0.10 inches shall be a failure.

4.5.2.3.2 Configuration II. Mount the lock on a test stand as shown in Figure 2A. Apply a force of 600 pounds to the bolt as shown in the Figure. Examine the case and bolt for damage. Any fracture or bending of the bolt or case shall be a failure. Apply a force of 200 pounds to the bolt as shown in Figure 3A. Any fracture or bending of the bolt or case, or damage to internal components shall be a failure.

Add new paragraphs:

4.5.2.5 Temperature tests.

4.5.2.5.1 Low temperature test. The lock shall be placed in a chamber maintained at a temperature of -10 degrees F for a period of three hours or until the lock temperature has stabilized. At the end of that period, without removing the lock from the chamber, ten attempts, using normal dialing procedures, shall be made to open the lock. The lock shall open at least six out of ten times.

FF-L-2740

Slower than normal operation of electromechanical lock designs is not considered failure. After ten attempts, the lock shall be removed from the chamber and allowed to return to room temperature. Ten more opening attempts shall be made. The lock shall open all ten times. The lock shall be examined for any damage or defects due to the low temperature exposure. There shall be no defects affecting the operation or life of the lock.

4.5.2.5.2 High temperature test. The lock shall be placed in a chamber maintained at a temperature of 155 degrees F for a period of three hours. At the end of that period, the lock shall be removed from the chamber and without allowing time for the lock to cool, the lock shall be opened five times using normal dialing procedures. The lock shall then be placed back in the chamber and the temperature shall be increased to 170 degrees F. After one hour, the lock shall be removed from the chamber and an attempt shall be made to open it. The lock bolt shall be blocked in the locked position.

4.6 Inspections. A visual inspection shall be made to determine compliance with the requirements specified in the following paragraphs:

- 3.3.3 Materials
- 3.4.1 Hand change locks
- 3.4.2 Key change locks
- 3.4.3 Bolt lockout
- 3.4.4 Combinations
- 3.4.5 Lock operation
- 3.4.6 Lock bolt operation
- 3.4.7 Combination redial
- 3.4.8 Case access
- 3.4.9 Wheel torque
- 3.4.13 Life safety feature
- 3.4.14 Automatic deadbolt mechanism
- 3.4.15 Strikes
- 3.4.18 Escape feature
- 3.5.2 Dial and dial rings
- 3.5.3 Spindle
- 3.5.4 Tubes
- 3.5.5 Case and cover
- 3.5.6 Lock bolt
- 3.5.7 Finish

3.5.8	Workmanship
3.7	Marking
3.9	Instructions

Page 16

Paragraph 6.2

Delete item (b) and substitute the following:

- b. Configuration, model, class, type, size and strike (as appropriate).

Page 17

Paragraph 6.4

Delete "og" and substitute "of".

Delete paragraph 6.5 and substitute the following:

6.5 Reference identification number. The reference identification number (RIN) system may be used for items covered by this specification. An example of the RIN is as follows:

For combination locks:

FFL2740 - A C N S

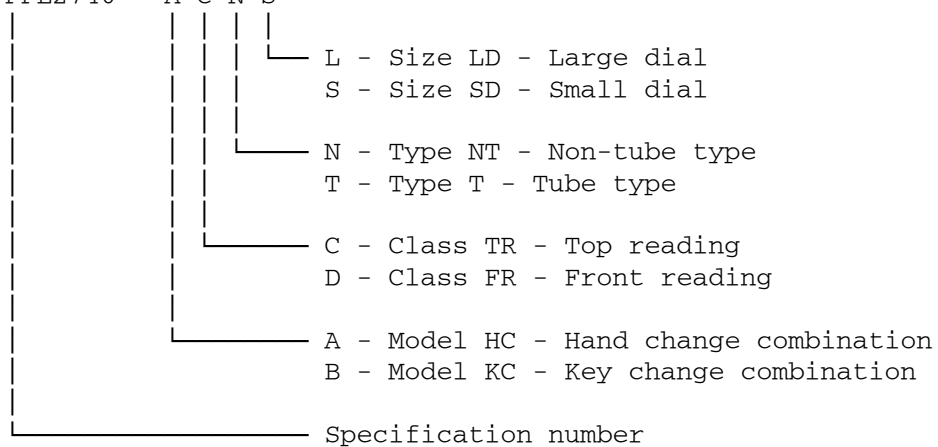

FF-L-2740

For pedestrian door combination deadbolt locks:

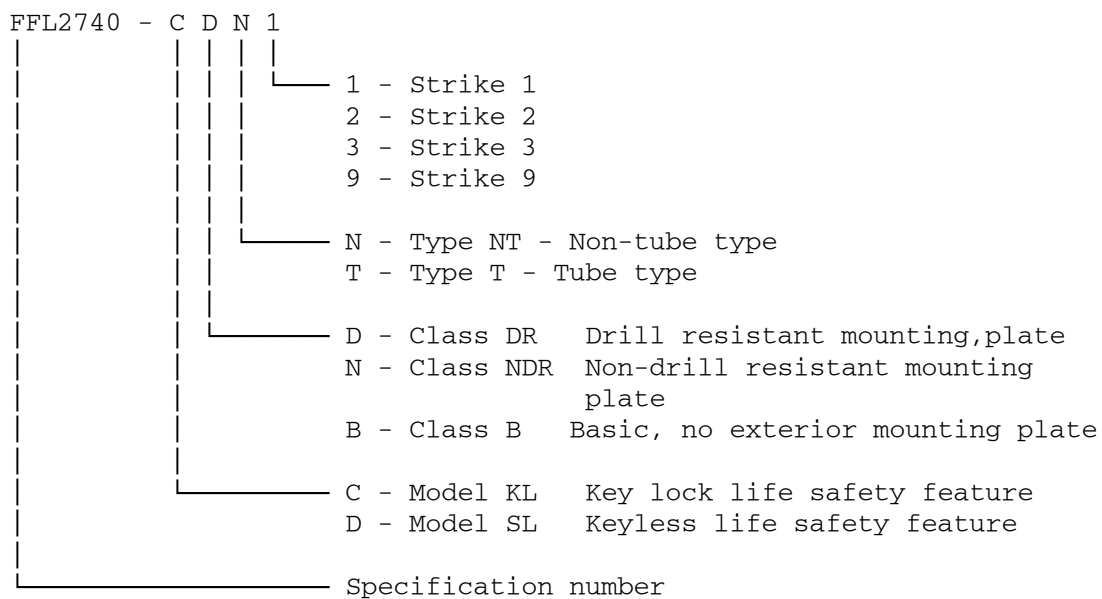

Page 18

Delete Figure 1 and substitute the attached Figure 1.

Add new Figures 2a, 3a, 4 and 5.

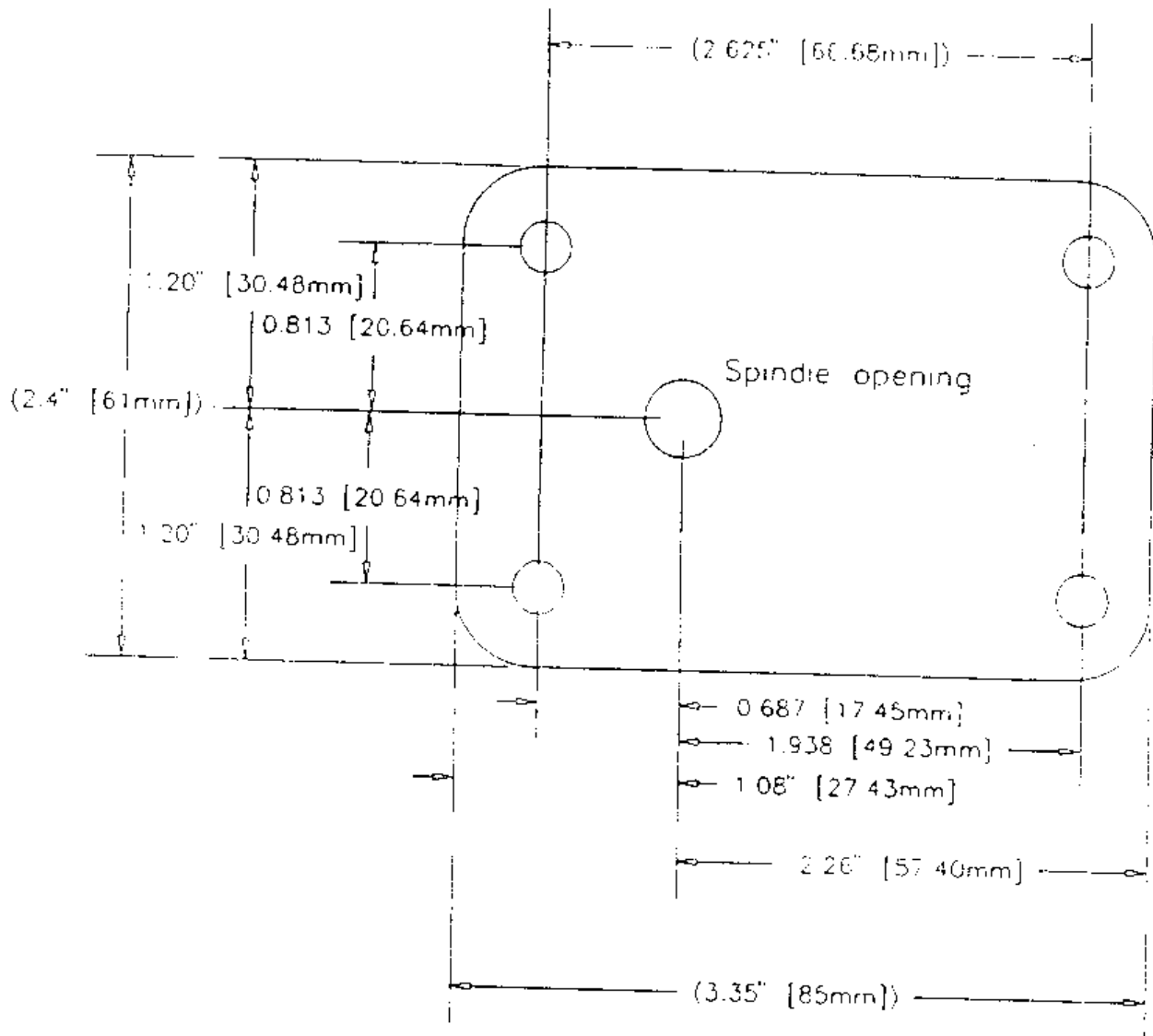

## Tolerances

XXXX ±0.01 [±0.25 mm]

XX.XXX ±0.005 [±0.13 mm]

FIGURE 1  
Schematic arrangement of lock case holes

FF-L-2740

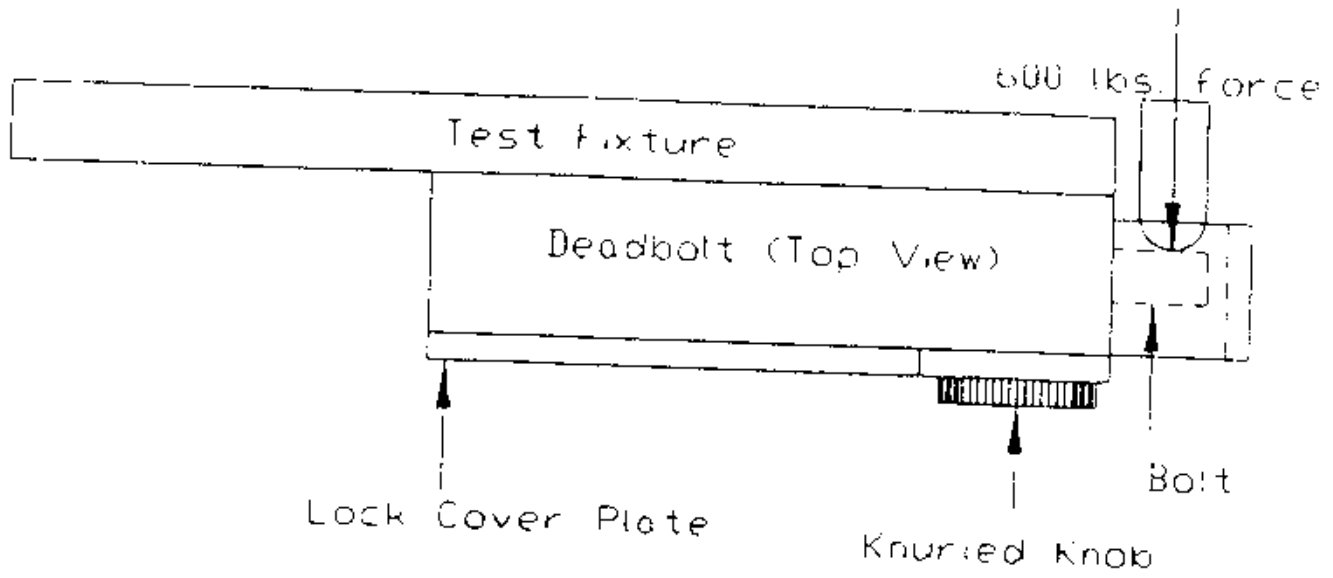

Figure 2c - Case and Bolt Strength Test

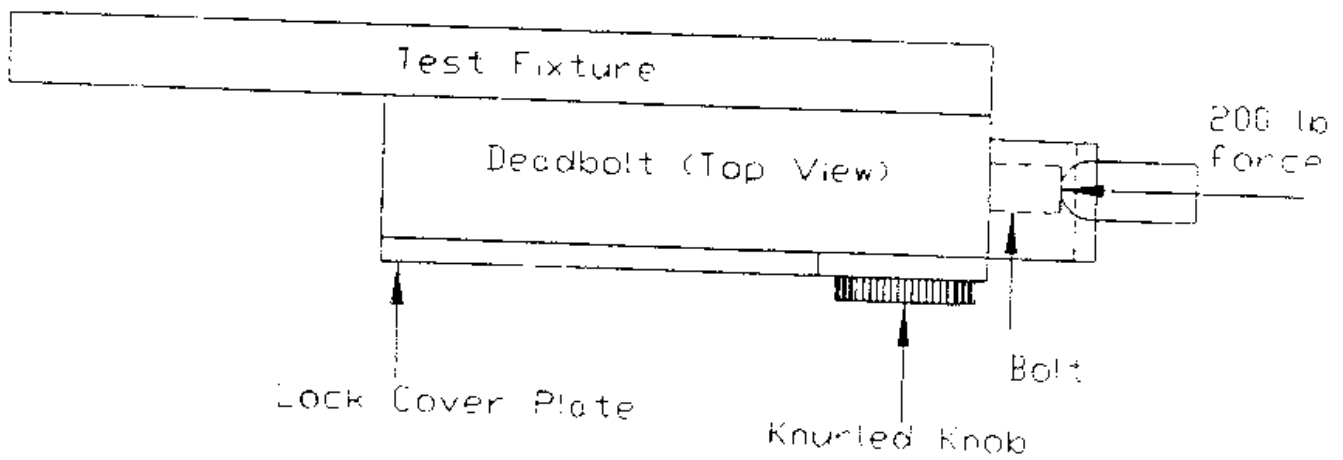

Figure 3a - Bolt End Pressure Test

### Pedestrian Door Lock Test Fixture

- (1) Vertically mounted, 3/8 inch thick steel plate approx. 19 inches wide by 11 inches
- (2) Drilled and tapped to allow for mounting deadbolt
- (3) Hinged to allow for cyclic test using strike  
Alternatively, the lock may be mounted to a fixed plate with the strike mounted to a moveable fixture

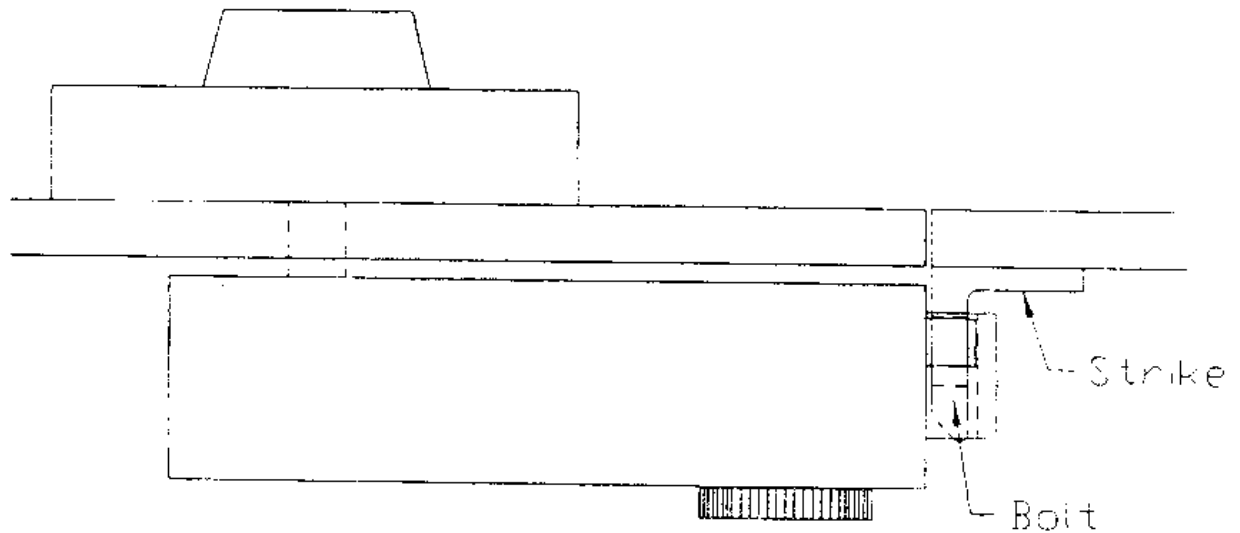
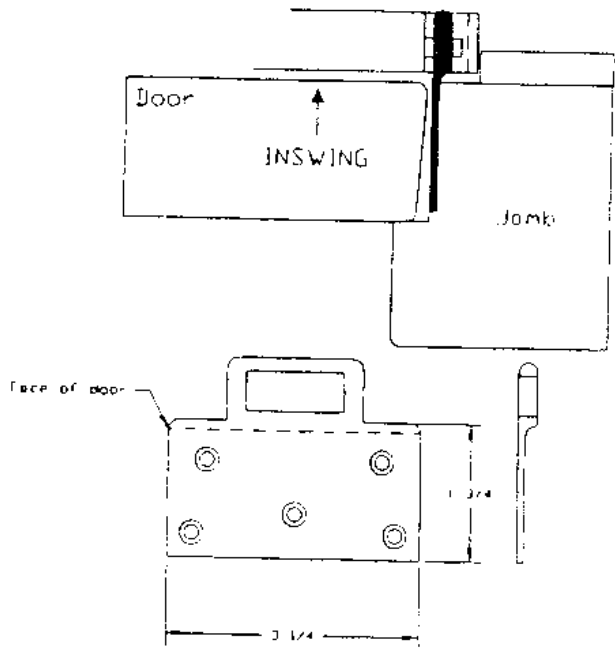

Figure 4 - Test Fixture Configuration.



FF-L-2740

Strike No. 1  
Single Door Regular Bevel or  
Double Door Regular Bevel



Strike No. 2  
Single Door Reverse Bevel

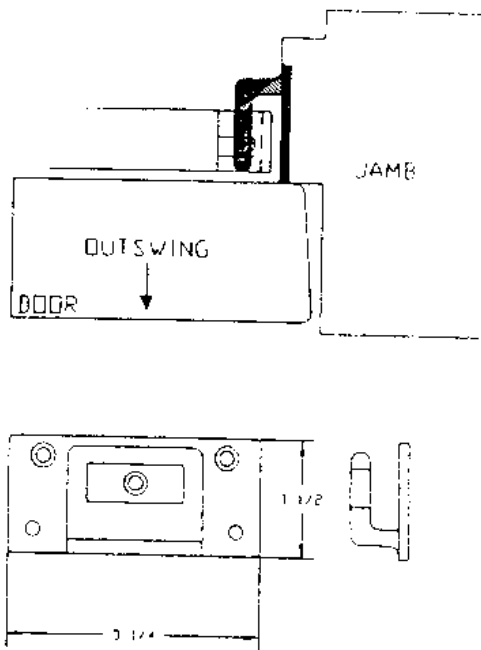

Strike No. 3  
Single Door Regular Bevel or  
Double Door Regular Bevel

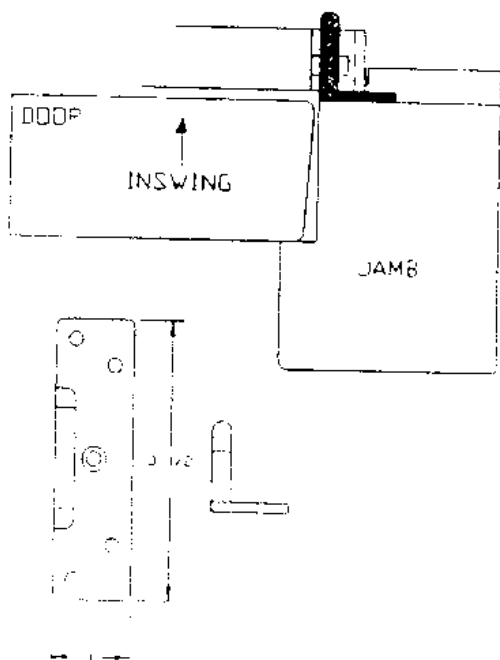

Strike No. 9  
Double Door Reverse Bevel

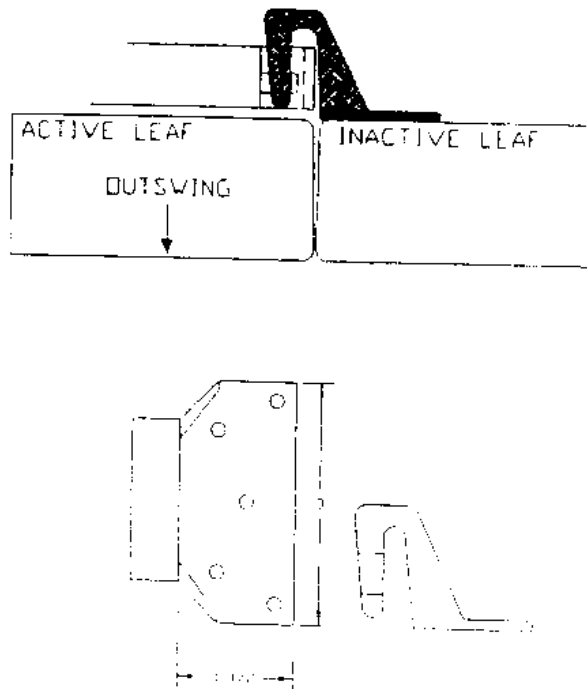

FIGURE 5 - Strike Configurations