

INCH-POUND
------------

FF-C-450F  
16 April 2012  
SUPERSEDING  
FF-C-450E  
9 March 2011

## FEDERAL SPECIFICATION

## CLAMPS, WIRE ROPE

The General Services Administration has authorized the use of this federal specification by all federal agencies.

## 1. SCOPE AND CLASSIFICATION

1.1 Scope. This specification covers clamps, wire rope, bolted, and clamps, wire rope, threaded. These clamps are also commercially known as clips, wire rope.

1.2 Classification.

1.2.1 Types and classes. Clamps are of the following types and classes (see 6.1).

Type I – Single grip, single saddle, with U-bolts and nuts (MS16842).

- Class 1. Steel saddle
- Class 2. Malleable-iron saddle

Type II – Double grip, double saddle, with U-bolt and nuts (FF-C-450/1).

Type III – Double grip, double saddle, with bolts and nuts (MS51868).

- Class 1. Assembled with integral L-shaped bolts and nuts (MS51868).
- Class 2. Assembled with separate hex headed bolts and nuts (MS51868).

Type IV – Double grip, two taper threaded half clamps with mating hexagon nut (MS16843).

## 2. APPLICABLE DOCUMENTS

2.1 Government publications. The following documents, of the issues in effect on the date of invitation for bids or request for proposal, form a part of the specification to the extent specified herein.

Federal Specifications

FF-C-450/1 – Clamp, Wire Rope, Double Saddled, Double-Grip, Steel

Federal Standards

FED-STD-H28 – Screw-Threads Standards For Federal Services

Military Specifications

MS16842 – Clamp, Wire Rope, Saddled, Single Grip, Steel  
MS16843 – Clamp, Wire Rope, (Double Grip), Threaded Steel  
MS51868 – Clamp, Wire Rope, Double Saddle, Double Grip, Steel

Comments, suggestions, or questions on this document should be addressed to DLA Land and Maritime, Columbus, ATTN: VAI, P.O. Box 3990, Columbus, OH 43218-3990, or email to [FluidFlow@dla.mil](mailto:FluidFlow@dla.mil). Since contact information can change, you may want to verify the currency of this address information using the ASSIST Online database at <https://assist.daps.dla.mil>.

## FF-C-450F

Military Standards

MIL-STD-130 – Identification Marking of U.S. Military Property

(Copies of these documents are available online at <https://assist.daps.dla.mil/quicksearch> or from the Standardization Document Order Desk, 700 Robbins Avenue, Building 4D, Philadelphia, PA 19111-5094.)

2.2 Other publications. The following documents form a part of this specification to the extent specified herein. Unless a specific issue is identified, the issue in effect on date of invitation for bids or request for proposal shall apply.

## ASME INTERNATIONAL

ASME-B18.2.2 – Square and Hex Nuts

(Copies of these documents are available online at <http://www.asme.org> or from the ASME International, Three Park Avenue, New York, NY 10016-5990.)

## ASTM INTERNATIONAL

ASTM-A47/A47M – Ferritic Malleable Iron Castings  
 ASTM-A153/A153M – Zinc Coating (Hot-Dip) on Iron and Steel Hardware  
 ASTM-B633 – Electrodeposited Coatings of Zinc on Iron and Steel  
 ASTM-B695 – Coatings of Zinc Mechanically Deposited on Iron and Steel  
 ASTM-E1444 – Standard Practice for Magnetic Particle Testing

(Copies of these documents are available online at <http://www.astm.org> or from the ASTM International, P.O. Box C700, 100 Barr Harbor Drive, West Conshohocken, PA 19428-2959.)

## INTERNATIONAL ORGANIZATION FOR STANDARDIZATION (ISO)

ISO 10012 – Measurement management systems — Requirements for measurement processes and measuring equipment

(Copies of these documents are available from <http://www.iso.ch> or to International Organization for Standardization American National Standards Institute, 11 West 42<sup>nd</sup> Street, 13<sup>th</sup> Floor, New York, NY 10036.)

## NCSL INTERNATIONAL

NCSL-Z540.3 – Requirements for the Calibration of Measuring and Test Equipment

(Copies of these documents are available from <http://www.ncsli.org> or to National Conference of Standards Laboratories (NCSL), 2995 Wilderness Place, Suite 107, Boulder, CO 80301-5404.)

## SAE INTERNATIONAL

SAE-AMS-QQ-P-416 – Plating, Cadmium (Electrodeposited)  
 SAE-J429 – Mechanical and Quality Requirements for Externally Threaded Fasteners

(Copies of these documents are available from SAE International, 400 Commonwealth Drive, Warrendale, PA 15096-0001, Tel: 877-606-7323 (inside USA and Canada) or 724-776-4970 of these documents (outside USA), [www.sae.org](http://www.sae.org).)

2.3 Order of precedence. Unless otherwise noted herein or in the contract, in the event of a conflict between the text of this document and the references cited herein (except for related specification sheets), the text of this

## FF-C-450F

document takes precedence. Nothing in this document, however, supersedes applicable laws and regulations unless a specific exemption has been obtained

### 3. REQUIREMENTS

3.1 Specification sheets. The individual item requirements shall be as specified herein and in accordance with the applicable specification sheets and military standards. In the event of any conflict between requirements of this specification and the specification sheets and military standards, the latter shall govern.

3.1.1 Type I, class 1 clamps (see MS16842). Materials for saddles, bolts, and nuts shall be carbon steel, the properties of which shall withstand, without distortion, the torque test of 4.4.2. Saddles shall be made of steel forgings for wire rope sizes up through 2 inches inclusive; of steel castings for wire rope sizes larger than 2 inches.

3.1.2 Type I, class 2 clamps (see MS16842). Material for bolts and nuts shall be carbon steel, the properties of which shall withstand, without distortion, the torque test of 4.4.2. Saddles shall be made of malleable iron, 32510, in accordance with ASTM-A47/A47M.

3.1.3 Type II clamps (see FF-C-450/1). Material for bolts, saddles, and nuts shall be carbon steel the properties of which shall withstand, without distortion, the torque test of 4.4.2. Saddles shall be made of forged steel.

3.1.4 Type III clamps (see MS51868). Material for Class 1 clamps and Class 2 saddles and nuts shall be carbon steel. Class 2 bolts shall be SAE-J429, grade 5 steel or better. The properties of all type III clamps shall withstand, without distortion, the torque test of 4.4.2. Class 1 saddles with integral L-shaped bolts and Class 2 saddles shall be forged.

3.1.5 Type IV clamps (see MS16843). Material for type IV clamp bodies shall be of forged steel 1035 to 1040. The mating hexagon nut shall also be made of 1035 to 1040 steel.

### 3.2 Bolts.

3.2.1 Bolt threads. Thread series of bolts after hot dip zinc (galvanized) coating, electrodeposited zinc coating, mechanically deposited zinc coating, or electrodeposited cadmium plating shall be Unified Coarse (UNC) Class 2A in accordance with FED-STD-H28.

3.2.2 Thread methods. Bolt threads may be rolled or cut at the option of the manufacturer. Threads shall not be recut or rerolled after hot dip zinc (galvanized) coating, electrodeposited zinc coating, mechanically deposited zinc coating, or electrodeposited cadmium plating.

### 3.3 Nuts.

3.3.1 Nut threads. Nut threads shall be of the same series and class as the bolts on which they are to be used (see 3.2.1). Hot dip zinc (galvanized) coated nuts shall be tapped after coating except those galvanized nuts used with type III, class 2 clamps whose threads shall be cut oversize prior to being hot dip (galvanized) coated and then recut after coating to maintain a proper fit with the mating bolt. Electrodeposited threaded nuts shall not be recut after coating and plating.

3.3.2 Type. Nuts for types I, II, and III clamps shall be heavy, hexagon, nuts or flat nuts in accordance with ASME-B18.2.2 except nuts for type I, class 2 (malleable iron) saddles shall conform to the hexagon, flat nut of ASME-B18.2.2.

3.4 Dimensions. Dimensions and weights of wire rope clamps shall see 3.1, as applicable, and as otherwise specified herein. Dimensional symbols are identified in see 3.1. Clamp sizes (see 3.1) are designated by the diameter of the wire rope with which they are used.

### 3.5 Construction.

3.5.1 Configuration. Configuration details of clamp components may be to the contractor's design; however, the clamps assembled shall be specified in FF-C-450/1, MS16842, MS16843, and MS51868, and shall conform to the applicable description of this specification (see 6.2).

## FF-C-450F

3.5.1.1 Type I clamps. Type I clamps shall be in accordance with MS16842. The inside width between the parallel U-bolts legs shall be at least 1/16 inch greater than the nominal wire rope diameter for size one inch and under and 1/8 inch greater for sizes over one inch. The thread length on U-bolt legs shall be sufficient to permit properly gripping a rope doubled over.

3.5.1.1.1 Saddles (Type I). Saddles for class 1 and 2 of type I clamps shall have a semicircular path running in the longitudinal direction of the rope, sided by two wings on each side of the path for guiding the U-bolt and nesting the wire rope. The rope path shall have corrugations to accommodate a rope having a right-hand helix. The two holes for the U-bolt legs shall be dimensioned and spaced to fit the legs without binding.

3.5.1.2 Type II clamps. Type II clamps shall be in accordance with FF-C-450/1. The width between the parallel U-bolt legs with saddles assembled shall accommodate the applicable wire rope. The thread length on the U-bolt legs shall be sufficient to permit the saddles to grip two ropes between saddles with nuts fully engaged.

3.5.1.2.1 Saddles (Type II). The “loop” saddle for type II clamps, which in the assemble is slipped between the U-bolt legs, shall be formed with outside grooves and two top ridges for centering and holding it inside the U-bolt loop. The “clamping” saddle shall be of a rectangular shape with taper ends and shall have the eyes dimensioned and spaced to fit the U-bolt legs without binding. The “loop” and “clamping” saddles shall be grooved for nesting the wire rope. These grooves shall be made with corrugations running in the direction of the rope strands of a rope having a right hand helix and they shall be formed to give the maximum grip in the longitudinal direction with the rope remaining straight.

3.5.1.3 Type III clamps. Type III clamps shall be in accordance with MS51868. The width between the bolts of the assembled clamp shall accommodate the applicable wire rope. The clamps shall have the eyes so dimensioned and spaced that the halves assemble without binding.

3.5.1.3.1 Bolts and saddles (Type III). The L-shaped bolt with integral clamp saddle for class 1 clamps shall be in accordance with MS51868 (see figure titled; “Clamp, double grip, double saddled wire rope – type III, class 1”). The saddle and bolt assembly for class 2 clamps shall be in accordance with MS51868 (see figure titled; “Clamp, double grip, double saddled wire rope – type III, class 2”). Saddles of both classes shall be grooved for nesting the wire rope. These grooves shall be made to run in the direction of the rope strands having a right-hand helix and they shall be formed to give the maximum grip in the longitudinal direction with the rope remaining straight. The thread length on the bolt section shall be sufficient to permit the saddles to grip two ropes between saddles with nuts fully engaged.

3.5.1.4 Type IV clamps. Type IV clamps shall be in accordance with MS16843. The threads of the component half clamps and nut shall be tapered and be in alignment when assembled. Each half clamp shall have the inside channel either cross corrugated or helically grooved for nesting the wire rope. Helical grooves shall run in the direction of the strands of a rope having a right-hand lay, unless a left-hand lay is specified (see 6.2). The nuts shall have no visible evidence of cracks and when specified (see 6.2) shall be capable of passing the magnetic particle test of 4.4.3.1.

3.5.2 Assembly. Clamps of the same size, type, and class, with the exception of type IV, shall assemble readily with random selection of component parts. Type IV half clamps are made in matching pairs and parts are not interchangeable.

3.5.3 Identification marking. Clamps shall be legibly and permanently marked with size and the manufacturer’s identifying mark in accordance with MIL-STD-130.

3.5.4 Protective finish. Protective coating shall be, mechanically deposited zinc coating in accordance with ASTM-B695, class 50, type II zinc coated (hot dip galvanized) in accordance with ASTM-A153/A153M or zinc coating (electrodeposited) in accordance with ASTM-B633, Fe/Zn 5, type VI (4.4.1).

3.5.4.1 Environmental safety note. If at all possible and for a safer environment, do not use cadmium or hexavalent chromate conversion. It is Recommend to use ASTM-B633, Fe/Zn 5, type VI.

3.5.5 Workmanship. All component parts of clamps shall be free of defects such as burrs, fins, sharp edges, cracks, flaws, corrosion, and malformations. Threads and corrugations shall be clean and properly formed. Coating, as specified (see 3.5.4), shall be adherent and shall cover all surfaces uniformly.

FF-C-450F

3.6 Performance.

3.6.1 Type I, II and III clamps. Types I, II, and III clamps shall be capable of passing the tests specified in 4.4.3.1.

3.6.2 Type IV clamps. The clamp grip shall be not less than 90 percent of its applicable wire rope rated breaking strength for sizes 1/4 inch and under and not less than 85 percent for sizes over 1/4 inch. Nuts for type IV clamps shall be capable of passing the magnetic particle test of 4.4.3.1 when such test is required in the contract or order (see 6.2).

4. QUALITY ASSURANCE PROVISIONS

4.1 Responsibility for inspection. Unless otherwise specified in the contract or purchase order, the contractor is responsible for the performance of all inspection requirements as specified herein. Except as otherwise specified in the contract or order, the supplier may use his own or any other facilities suitable for the performance of the inspection requirements specified herein, unless disapproved by the Government. The Government reserves the right to perform any of the inspections set forth in the specification where such inspections are deemed necessary to assure that supplies and services conform to prescribed requirements.

4.1.1 Test equipment and inspection facilities. The contractor shall establish and maintain a calibration system in accordance with ISO 10012 and NCSL-Z540.3.

4.2 Quality conformance inspection. Quality conformance inspection shall consist of the tests in 4.3.

4.2.1 Inspection lot. An inspection lot shall consist of clamps of the same type, class, material, protective coating, thread series, and size produced under essentially the same conditions and presented for acceptance at the same time.

4.2.2 Sampling tests. A sample of clamps shall be randomly selected in accordance with table I, if one or more defects are found, the lot shall be rescreened and defects removed. After screening and removal of defects, a new sample of clamps shall be randomly selected in accordance with table I, if one or more defects are found in the second sample, the lot shall be rejected and shall not be supplied to this specification. in accordance with table I. The selected clamp type shall be subjected to all the sampling tests listed in 4.3 and 4.4

4.2.2.1 Rejection and retest. When one or more clamps fail to meet the specification, acceptance of all clams will be withheld until the extent and cause of failure are determined. After corrections have been made, all necessary tests shall be repeated.

4.2.2.2 Sampling plan. Accept on zero, for general inspection as specified in table I.

## FF-C-450F

TABLE I. Sampling plan.

Lot Size			Sample size
2	to	8	<u>1/</u>
9	to	15	13 <u>1/</u>
16	to	25	13
26	to	50	13
51	to	90	13
91	to	150	13
151	to	280	20
281	to	500	29
501	to	1,200	34
1,201	to	3,200	42

1/ Indicates entire lot must be inspected or sample size not to exceed lot size.

4.2.3 Sampling for protective finish tests. Sampling for tests of protective finishes shall be in accordance with the applicable specifications of 3.5.4.

4.2.4 Sampling for torque test. A random sample of types I, II and III clamps, as applicable, see 4.2.2.

4.2.5 Sampling of type IV nuts for magnetic particle inspection (see 6.2). When magnetic particle inspection is specified in the contract or order, a random sample of type IV nuts shall be taken from each lot see 4.2.2.

#### 4.3 Examination.

4.3.1 Visual and dimensional inspection. Each clamp taken as specified in 4.2.2 shall be examined to verify compliance with this specification. Examination shall be conducted in accordance with table I. Any clamp in the sample containing one or more defects shall be rejected and if the number of defective clamps exceeds the acceptable number for the sample, the lot represented by the sample shall be rejected.

#### 4.4 Test procedures.

4.4.1 Protective coating test. Test of protective coating shall be conducted in accordance with the applicable specifications of 3.5.4.

4.4.2 Torque test of types I, II, and III clamps. Unless otherwise stated in contract or order, each sample of 4.2.5 shall be tested by the contractor as follows (see 3.1.1, 3.1.2, 3.1.3, 3.1.4):

4.4.2.1 Test method. Two steel rods, of the same diameter as the wire rope for which the clamp is intended, shall be inserted in the clamp opening (see figure 1). The clamp nuts shall be tightened with a torque wrench to the applicable torque values specified in table II. Tightening shall be accomplished progressively by applying torque alternately to each nut in increments of ten percent of the maximum torque values for the size clamp being tested. The maximum torque on each nut shall be held for ten minutes. After the ten minute period, clamps shall be disassembled and visually examined for distortion, then tested by being reassembled and disassembled by hand without tools. Clamps unable to perform this test shall be considered defective. This torque test does not apply to type IV clamps.

4.4.3 Test of type IV clamps. The contractor shall furnish an Underwriter's Laboratories, Inc. approved test report. When this listing is not available, the contractor shall submit proof that the clamp grip conforms to 3.6.2.

4.4.3.1 Magnetic particle test of type IV nuts. When specified in the contract or order, type IV nuts shall be examined and tested in accordance with ASTM-E1444 (see 6.2).

4.4.4 Malleable-iron test. When malleable-iron saddles (type I, class 2 clamps) are specified, the contractor shall furnish, prior to production, a test report by a laboratory acceptable to the Government that the malleable-iron

## FF-C-450F

employed for saddles meets the requirements of 3.1.2. In lieu of such report, the contractor shall carry out necessary tests of the iron under Government surveillance to show conformance with 3.1.2.

TABLE II. Torque values for torque testing only 1/  
(Applies to wire rope clamp nuts).

Nominal clamp size wire rope	Nut torque				
	Type I		Type II	Type III	
	Class 1	Class 2		Class 1	Class 2
1/8 (.125)	34 in-lbs		34 in-lbs	34 in-lbs	
3/16 (.188)	66 in-lbs	32 in-lbs	78 in-lbs	78 in-lbs	14 ft-lbs
1/4 (.250)	12 ft-lbs	12 ft-lbs	144 in-lbs	144 in-lbs	24 ft-lbs
5/16 (.313)	18.5 ft-lbs	12 ft-lbs	222 in-lbs	222 in-lbs	40 ft-lbs
3/8 (.375)	25 ft-lbs	18.5 ft-lbs	25 ft-lbs	25 ft-lbs	66 ft-lbs
7/16 (.438)	35 ft-lbs	18.5 ft-lbs	35 ft-lbs	35 ft-lbs	100 ft-lbs
1/2 (.500)	35 ft-lbs	25 ft-lbs	43 ft-lbs	43 ft-lbs	100 ft-lbs
9/16 (.563)	50 ft-lbs	35 ft-lbs	50 ft-lbs	50 ft-lbs	146 ft-lbs
5/8 (.625)	50 ft-lbs	35 ft-lbs	75 ft-lbs	75 ft-lbs	146 ft-lbs
3/4 (.750)	100 ft-lbs	50 ft-lbs	100 ft-lbs	100 ft-lbs	200 ft-lbs
7/8 (.875)	140 ft-lbs	100 ft-lbs	140 ft-lbs	140 ft-lbs	335 ft-lbs
1 (1.000)	140 ft-lbs	100 ft-lbs	190 ft-lbs	190 ft-lbs	335 ft-lbs
1-1/8 (1.125)	140 ft-lbs	140 ft-lbs	220 ft-lbs	220 ft-lbs	335 ft-lbs
1-1/4 (1.250)	275 ft-lbs	140 ft-lbs	275 ft-lbs	275 ft-lbs	500 ft-lbs
1-3/8 (1.375)	275 ft-lbs	275 ft-lbs	340 ft-lbs	340 ft-lbs	500 ft-lbs
1-1/2 (1.500)	275 ft-lbs	275 ft-lbs	420 ft-lbs	420 ft-lbs	775 ft-lbs
1-5/8 (1.625)	420 ft-lbs		480 ft-lbs	480 ft-lbs	
1-3/4 (1.750)	590 ft-lbs		590 ft-lbs	590 ft-lbs	
2 (2.000)	750 ft-lbs		750 ft-lbs	750 ft-lbs	
2-1/4 (2.250)	750 ft-lbs		820 ft-lbs	820 ft-lbs	
2-1/2 (2.500)	750 ft-lbs		1150 ft-lbs	1150 ft-lbs	
2-3/4 (2.750)	750 ft-lbs		1450 ft-lbs	1450 ft-lbs	
3 (3.000)	1200 ft-lbs		1650 ft-lbs	1650 ft-lbs	

1/ Not to be used for application nut torque values.

## 5. PACKAGING

5.1 Packaging. For acquisition purposes, the packaging requirements shall be as specified in the contract or order (see 6.2). When packaging of materiel is to be performed by DoD or in-house contractor personnel, these personnel need to contact the responsible packaging activity to ascertain packaging requirements. Packaging requirements are maintained by the Inventory Control Point's packaging activities within the Military Service or Defense Agency, or within the military service's system commands. Packaging data retrieval is available from the managing Military Department's or Defense Agency's automated packaging files, CD-ROM products, or by contacting the responsible packaging activity.

## 6. NOTES

INFORMATION FOR GUIDANCE ONLY. This section contains information of a general or explanatory nature that is helpful, but is not mandatory.

### 6.1 Intended use.

6.1.1 Type I, II and III clamps, bolted. Types I, II and III wire rope clamps are intended for use on wire rope eye-loop connections or complete-loop, end-to-end connections where socketing or splicing is not feasible when a nonpermanent or temporary joint is required. The clamps also may be used in an end-to-end connection to make a continuous length wire rope, but in emergency cases only.

6.1.2 Single-saddle clamps. Single-saddle wire rope clamps, type I, may be used interchangeably with double-saddle wire rope clamps, type II and type III, class 1, on wire ropes of the same diameter but should not be used

## FF-C-450F

interchangeably with type III, class 2 clamps. Single-saddle wire rope clamps should be placed on eye-loop connections with their U-bolts on the dead or short end of the rope.

6.1.3 Positioning of components. Wire rope clamps should be placed on the wire rope connection with the corrugations in their saddles coinciding with the lay of the wire rope. The nuts on the clamps should be retightened immediately after the initial loading, and at frequent intervals of time thereafter. For the recommended number of type I, class 1 clamps, see MS16842, for type III, class 1 or class 2 clamps, see MS51868.

6.1.4 Type IV clamps, threaded. Type IV wire rope clamps consist of a split, taper thread body and mating hexagonal nut and are intended for use on wire rope eye-loops.

6.2 Ordering data. Purchasers should select the preferred options permitted herein and include the following information in procurement documents:

- Title, number, and date of this specification.
- Type, class, size, and quantity of each.
- Lay, if left handed (see 3.5.1.4).
- Protective finish requirements if other than hot dip galvanized (see 3.5.4).
- Design sample, if required (see 3.5.1).
- Magnetic particle inspection, if required (see 4.4.3.1).

6.3 Military procurement. Personnel within the Military Departments shall refer to MS16842 for type I, class 1 clamps, MS51868 for type III, class 1 and class 2 clamps, and MS16843 for type IV clamps.

6.4 Item name. Defined in accordance with the approved item name in Cataloging Handbook H6, "Clamps, wire rope, bolted" and "Clamps, wire rope, threaded" covered by this specification are also identified as "Clips, wire rope" by manufacturers and commercial users.

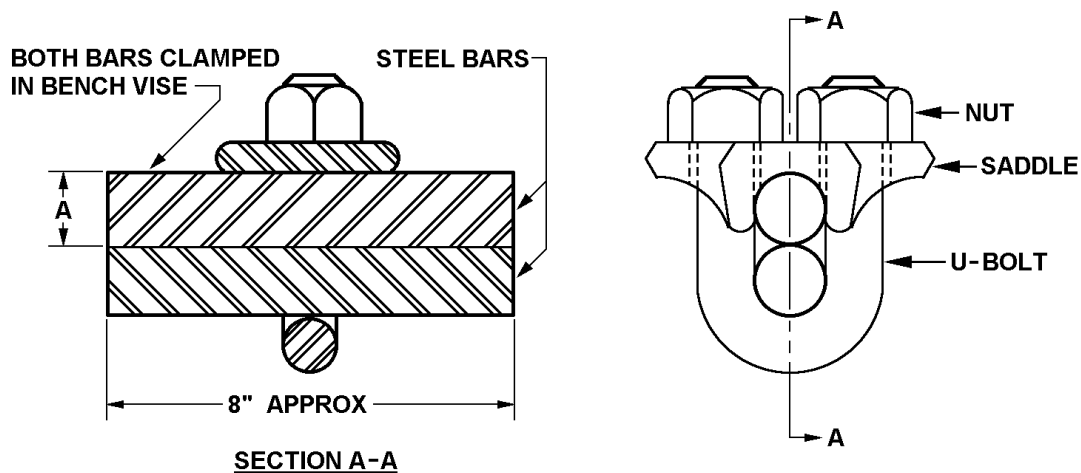

FIGURE 1. Arrangement for tightening wire rope clamps over steel bars (see 4.4.2.1).

6.5 Subject term (key word) listing.

Bolts  
Magnetic  
Malleable  
Nuts  
Saddle



## FF-C-450F

6.6 Environmentally preferable material. Environmentally preferable materials should be used to the maximum extent possible to meet the requirements of this specification. As of the dating of this document, the U.S. Environmental Protection Agency (EPA) is focusing efforts on reducing 31 priority chemicals. The list of chemicals and additional information is available on their website <http://www.epa.gov/osw/hazard/wastemin/priority.htm>. Included in the list of 31 priority chemicals are cadmium, lead, and mercury. Use of these materials should be minimized or eliminated unless needed to meet the requirements specified herein (see section 3).

6.7 Changes from previous issue. The margins of this specification are marked with vertical lines to indicate where changes from the previous issue were made. This was done as a convenience only and the Government assumes no liability whatsoever for any inaccuracies in these notations. Bidders and contractors are cautioned to evaluate the requirements of this document based on the entire content irrespective of the marginal notations and relationship to the last previous issue.

## CONCLUDING MATERIAL

## MILITARY INTERESTS:

## Custodians:

Army – AR  
Navy – SH  
Air Force – 99  
DLA – CC

## Review activities:

Army – AT, AV, CR4, GL  
Navy – MC, SA, YD  
Air Force – 71

## CIVIL AGENCY COORDINATING ACTIVITY

GSA – FSA

Preparing activity:  
DLA – CC

(Project 4030-2012-001)

NOTE: The activities listed above were interested in this document as of the date of this document. Since organizations and responsibilities can change, you should verify the currency of the information above using the ASSIST Online database at <https://assist.daps.dla.mil>.