

[INCH-POUND]
 F-F-351/2
 May 15, 1998
 SUPERSEDING
 (see Note 8)

FEDERAL SPECIFICATION SHEET

FILTER, FLUID PRESSURE: OIL, HEAVY DUTY, BY-PASS
 TYPE, SENIOR SIZE (BASE MOUNTED)

The General Services Administration has authorized the use of this federal specification sheet by all federal agencies.

The complete requirements for procuring the oil filter described herein shall consist of this document and the latest issue of Federal Specification F-F-351/GEN.

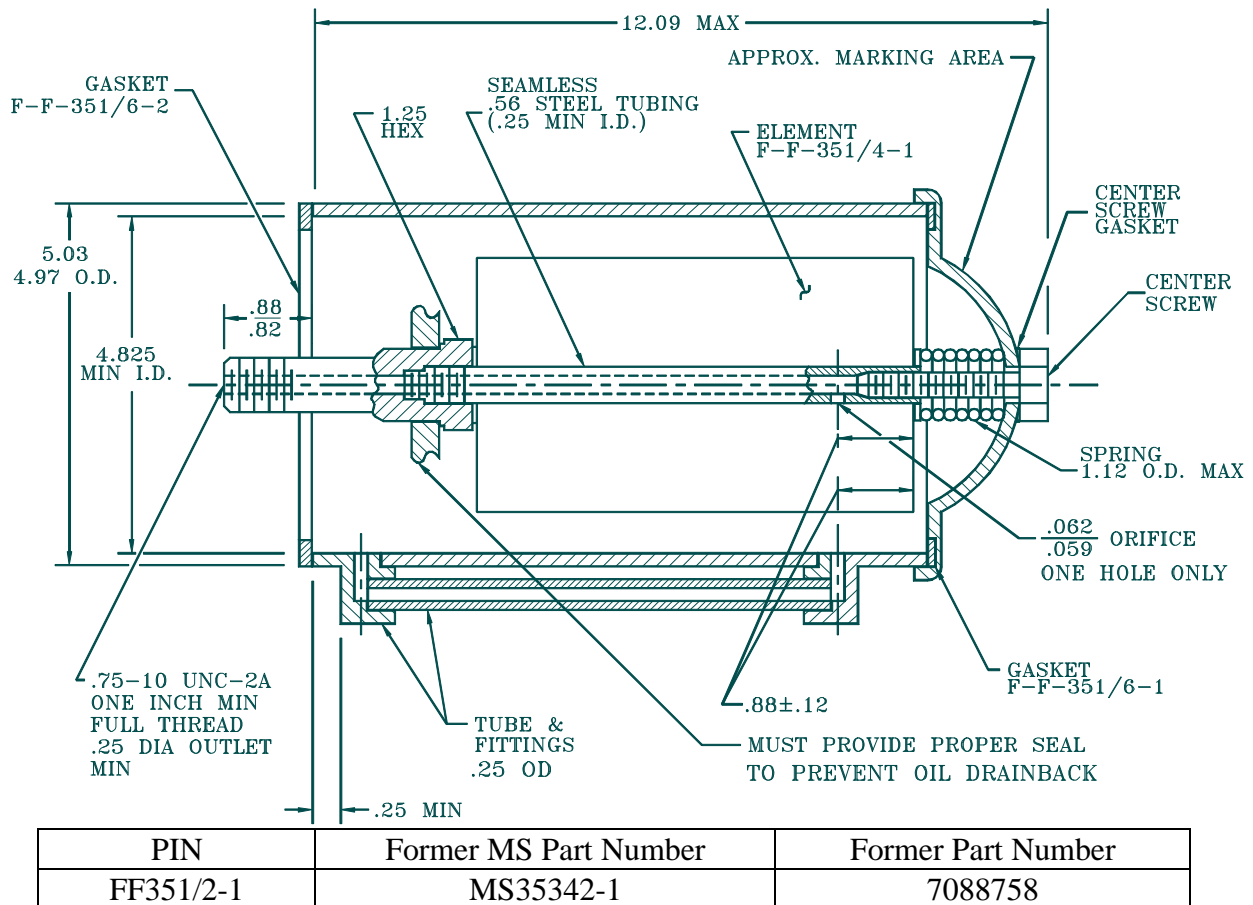

Figure 1. Filter assembly with element.

AMSC N/A

FSC 2940

DISTRIBUTION STATEMENT A. Approved for public release, distribution is unlimited.

F-F-351/2

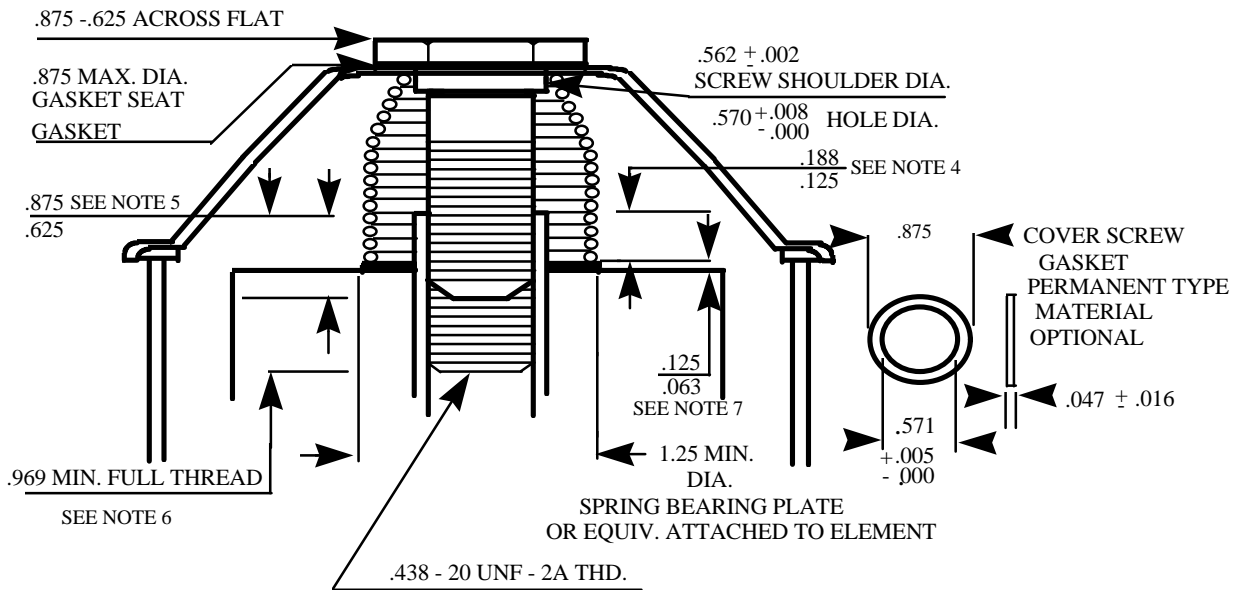
Figure 2. Filter assembly dimensions.**REQUIREMENTS**

1. Type I, class 3 of procurement specification (oil filter, heavy duty, senior size).
2. Screw threads shall be in accordance with FED-STD-H28/2.

NOTES:

1. Unless otherwise specified, dimensions are in inches.
2. This specification sheet is not intended to limit construction to features other than as shown hereon by dimensions, notations or referenced documents.
3. For design feature purposes, this specification slash sheet takes precedence over procurement documents referenced herein.
4. Dimension is rise of center tube above spring bearing plate.
5. Dimension is length of cover screw threaded into center tube.
6. Dimension is length of center tube that is threaded.
7. Dimension is thickness of spring bearing plate.
8. This specification sheet supersedes MS35342D, dated 12 December 1979, in part. MS35342-1 has been replaced by F-F-351/2-1. MS35342-2 has been cancelled without replacement.

F-F-351/2

MILITARY INTERESTS:

Custodians:

Army - AT
Navy - SH
Air Force - 99

Review Activities:

Army - AR, AV, CR4, MI
Navy - AS, MC

CIVIL AGENCY COORDINATING ACTIVITY:

GSA - FSS

Preparing Activity:

Army - AT

(Project 2940-0169)