



FAA-E-3007
With Change 1
June 16, 2009

SUPERSEDING
FAA-E-3007
September 30, 2008

DEPARTMENT OF TRANSPORTATION

FEDERAL AVIATION ADMINISTRATION

PERFORMANCE SPECIFICATION

FOUR BOX, Light Emitting Diode
PRECISION APPROACH PATH INDICATOR (PAPI)
Version A
June 16, 2009

DISTRIBUTION STATEMENT A. Approved for public release; distribution is unlimited

TABLE OF CONTENTS

1.0	SCOPE	1
1.1	Scope	1
2.0	APPLICABLE DOCUMENTS	1
2.1	FAA Documents	1
2.1.1	FAA Specifications	1
2.1.2	FAA Standards.....	1
2.1.3	FAA Drawings.....	1
2.1.4	FAA Management Documents	1
2.1.4	FAA Advisory Circulars.....	1
2.2	Military and Federal Publications.....	2
2.2.1	Military Specifications.....	2
2.2.1.1	Military Publications.....	2
2.2.2	Military Standards	2
2.2.3	Federal Specifications.....	2
2.2.4	Federal Standards.....	2
2.2.5	Federal Communications Commission Rules and Regulations	2
2.3	Other Publications	3
2.3.1	National Electrical Manufacturers Association (NEMA) standards	3
2.3.2	American National Standards Institute	3
2.3.3	National Fire Protection Association Publications	3
2.3.4	Masters Painters Institute (MPI).....	3
2.3.5	American Society for Testing and Materials (ASTM).....	3
2.3.6	Institute for Printed Circuits.....	3
2.3.7	Society of Automotive Engineers	3
2.3.8	Underwriters Laboratories Inc	3
3.	REQUIREMENTS	5
3.1	General Functional Requirements.....	5
3.2	Photometric Requirements.....	6
3.2.1	Light Beam	6
3.2.2	Light Intensity.....	6
3.2.3	Light Colors.....	7
3.2.4	Light Beam Aiming Tolerance	7
3.3	Sub-assemblies	7
3.3.1	Lamp Housing Assembly.....	7
3.3.1.1	Lamp Housing Assembly General	7
3.3.1.2	Lamp Housing Assembly Operational Requirements	9
3.3.1.3	Lamp Housing Assembly Enclosure	9
3.3.1.4	Lamp Housing Assembly Components.....	11
3.3.1.5	Lamp Housing Assembly Finish.....	13
3.3.2	Power and Control Assembly	13
3.3.2.1	Power and Control Assembly General.....	13
3.3.2.2	Power and Control Assembly Operational Requirements.....	14
3.3.2.3	Power and Control Assembly Cabinet.....	15
3.3.2.4	Power and Control Assembly Components	15
3.3.2.5	Power and Control Assembly Finish.....	17
3.3.3	Aiming Instrument Set and Calibration Bar	17
3.3.3.1	Clinometer.....	17
3.3.3.2	Calibration Bar.....	18
3.3.3.3	Carrying and Storage Case.....	18
3.4	Monitored Points and Controls	18
3.4.1	External signals.....	18
3.5	Electrical Components.....	20
3.5.1	Electrical Connectors.....	20
3.5.2	Printed Wiring Boards	20
3.5.3	Component Ratings	20
3.5.4	Fiber Optics	20
3.6	Materials and parts.....	20

3.6.1	Metals	20
3.6.2	Aluminum	20
3.6.3	Optical covers	20
3.6.4	Gaskets.....	20
3.6.5	Nameplates	20
3.7	Interchangeability	20
3.8	Finishes	21
3.8.1	Paint.....	21
3.9	Environmental Requirements	21
3.9.1	Temperature.....	21
3.9.2	Altitude	21
3.9.3	Temperature Shock (Thermal Shock).....	21
3.9.4	Humidity.....	21
3.9.5	Sand and Dust.....	21
3.9.6	Rain.....	21
3.9.7	Salt Spray.....	22
3.9.8	Solar Radiation (Sunshine).....	22
3.9.9	Vibration.....	22
3.9.10	Ice Accumulation.....	22
3.10	Transient Suppression.....	22
3.11	Electromagnetic Interference Control.....	22
3.11.1	Conducted Emissions.....	22
3.11.2	Radiated Emissions.....	22
3.11.3	Conducted Susceptability	23
3.11.4	Radiated Susceptability.....	23
3.12	Electrical Safety.....	23
3.12.1	Dielectric Strength.....	23
3.12.2	Ground Bonding	23
3.13	Assembly, Wiring and Marking.....	23
3.13.1	Assembly	23
3.13.2	Wiring.....	23
3.13.3	Marking	24
3.14	Workmanship.....	24
3.15	Brazing	24
3.16	Soldering.....	24
3.17	Maintainability.....	24
3.17.1	Maintainability Design Criteria	24
3.18	Reliability Design Criteria.....	24
3.18.1	System Reliability Parameters.....	24
3.19	Expected Life of Product.....	24
3.20	Software.....	25
4	VERIFICATION	26
4.1	VRTM.....	26
4.2	Test Articles.....	26
4.3	PAPI Requirements Testing Discussion.....	26
4.4.1	Test Methods	27
4.4.1	Design qualification test	27
4.4.2	Production Unit Tests.....	28
4.4.1	Visual Tests	29
4.5	Test Procedures.....	29
4.5.1	Visual Inspection	30
4.5.2	Altitude Test.....	30
4.5.3	Temperature Test.....	30
4.5.4	Sand and Dust Test.....	30
4.5.5	Salt Fog Test.....	30
4.5.6	Rain Test.....	30
4.5.7	Humidity Test.....	30
4.5.8	Thermal Shock Test.....	31
4.5.9	Solar Radiation (Sunshine) Test.....	31
4.5.10	Vibration Test.....	31

4.5.11	Electrical Safety.....	32
4.5.12	Transient Suppression Test.....	32
4.5.13	Electromagnetic Interference Test.....	32
4.5.14	Lampout Operational Test.....	33
4.5.15	Lamp Housing Assembly Aiming Test.....	33
4.5.16	First Article Photometric Test.....	33
4.5.17	Production Unit Photometric Test.....	33
4.5.18	Clinometer Test.....	33
4.5.19	Power and Control Assembly Performance Test.....	33
4.5.20	1000-Hour Operational Test.....	33
4.5.21	Two-hour Operational Test.....	34
4.5.22	Tilt Fault Detection System Test.....	34
4.5.23	Ice Accumulation Performance Test.....	34
4.5.24	LHA Tilt Detection Test.....	35
4.5.25	Input Power Test.....	35
4.5.25	Rigidity Test.....	35
4.6	Test Performance.....	35
5.	PACKAGING.....	36
6.	NOTES.....	36
6.1	Cross-reference with NAS-SS-1000.....	36
6.2	Mounting hardware not furnished under this contract.....	36
6.3	Flashing PAPI.....	36

TABLE OF TABLES

Table I,	PAPI system monitored points.....	18
Table II,	PAPI system monitored points, PCA origin.....	19
Table III,	Design Qualification Tests.....	28
Table IV,	Production Acceptance Tests.....	29
Table V,	Type Tests.....	29
Table VI,	Vibration Test Data.....	31

TABLE OF FIGURES

Figure 1.	PAPI System Signal Presentations.....	5
Figure 2.	PAPI Approach Path (Side View).....	6
Figure 3.	Light Intensity Requirements for PAPI.....	7
Figure 4.	Lamp Housing Assembly (Side View).....	8
Figure 5.	LHA mounting pad.....	9
Figure 6.	Functional Relationship of PAPI Units.....	14

TABLE OF APPENDICES

APPENDIX A.	Verification of Requirements Traceability Matrix (VRTM).....	37
APPENDIX B	NAS-SS-1000 Requirements Trace.....	54

Summary of Changes to FAA-E-3007

Version	Description	Date	Description of Change
FAA-E-3007	Original	September 30, 2008	
FAA-E-3007, Version A	Original Specification with Change 1	June 16, 2009	Changes the color temperature range in paragraph 3.2.3 on page 7 and in Item # 9 on page 37. Change approved by FAA NAS Configuration Control Board, CCD # 32522

9/30/2008

FAA-E-3007

1.0 SCOPE

1.1 Scope. This specification sets forth the requirements for a Precision Approach Path Indicator (PAPI) that is used to provide accurate approach path guidance to pilots of landing aircraft. The PAPI consists of four Lamp Housing Assemblies (LHA), a Power and Control Assembly (PCA), and an aiming instrument set if an aiming device is not built into the LHA. This specification specifically addresses the use of light emitting diode (LED) illumination sources that will replace incandescent bulb technology. The use of LED illumination sources in lieu of incandescent bulbs shall meet all PAPI operation requirements, provide much improved reliability and maintainability characteristics, and will significantly reduce life-cycle system operational costs.

2.0 APPLICABLE DOCUMENTS

2.1 FAA Documents. The following FAA specifications, standards, and drawings form a part of this specification and are applicable to the extent specified herein. Applicable revision levels are as shown here.

2.1.1 FAA Specifications.

FAA-D-2494B	Technical Instruction Book Manuscripts: Electronic, Electrical and Mechanical Equipment, Requirement for Preparation of Manuscript and Production of Books.
FAA-G-2100H	Electronic Equipment, General Requirements

2.1.2 FAA Standards.

FAA-STD-019H	Lightning and Surge Protection, Grounding, Bonding and Shielding Requirements for Facilities and Electronic Equipment
FAA-STD-026A	NAS Software Development
FAA-STD-049-	Fiber Optics Standard for Telecommunications Systems and Equipment

2.1.3 FAA Drawings.

C-6046-	Frangible Coupling, Types 1 and 1A, Details
---------	---------------------------------------------

2.1.4 FAA Management Documents. (Not Used)

2.1.5 FAA Advisory Circulars

150/5345-28F.	Precision Approach Path Indicator (PAPI) Systems.
---------------	---------------------------------------------------

9/30/2008

FAA-E-3007

2.2 Military and Federal Publications. The following military and federal publications, of the issues specified, form a part of this specification and are applicable to the extent specified herein.

2.2.1 Military Specifications.

MIL-A-8625F	Anodic Coatings, for Aluminum and Aluminum Alloys
MIL-C-5541E	Chemical Conversion Coatings on Aluminum and Aluminum Alloys

2.2.1.1 Military Publications.

MIL-HDBK-454A	Standard General Requirements for Electronic Equipment
MIL-HDBK-472-	Maintainability Predictions

2.2.2 Military Standards.

Mil-STD-202G	Electronic and Electrical Component Parts
MIL-STD-276A	Impregnation of Porous Nonferrous Metal Castings
MIL-STD-461E	Electromagnetic Emission and Susceptibility Requirements for the Control of Electromagnetic Interference
MIL-STD-810F	Environmental Test Methods
MIL-STD-889B	Dissimilar Metals
MIL-STD-961E	Department of Defense Standard Practice for Defense Specifications
MIL-STD-1472F	Department of Defense Design Criteria Standard

2.2.3 Federal Specifications.

TT-P-1757B	Primer Coating, Zinc Chromate, Low Moisture Sensitivity
------------	---------------------------------------------------------

2.2.4 Federal Standards.

FED-STD-595C	Color
--------------	-------

2.2.5 Federal Communications Commission Rules and Regulations

Part 15 Subpart J	Radio Frequency Devices, Equipment Authorization Procedures
----------------------	-------------------------------------------------------------

9/30/2008

FAA-E-3007

2.3 Other Publications. The following publications, of the issues in effect on the date of the invitation for bids or RFPs, form a part of this specification and are applicable to the extent specified herein.

2.3.1 National Electrical Manufacturers Association (NEMA) standards.

NEMA 4 Watertight and Dust Tight Indoors and Outdoors (Enclosure)

2.3.2 American National Standards Institute.

ANSI C61.1 Quantities and Units Used in Electricity

2.3.3 National Fire Protection Association Publications.

NFPA No. 70 National Electrical Code

2.3.4 Masters Painters Institute (MPI).

QPL-TT-E-489-48, MPI # 48 Interior Alkyd, Gloss

MPI # 49 Interior Alkyd, Flat

2.3.5 American Society for Testing and Materials (ASTM).

B26 Aluminum-Alloy Sand Castings

B85 Aluminum-Alloy Die Castings

B108 Aluminum-Alloy Permanent Mold Castings

B209 Aluminum and Aluminum-Alloy Sheet and Plate

B211 Aluminum and Aluminum-Alloy, Bar, Rod, and Wire

B221 Aluminum and Aluminum Alloy Extruded Bars, Rods, Shapes and Tubes

B241 Pipe, Seamless, and Seamless Extruded Tube, Aluminum and Aluminum-Alloy

2.3.6 Institute for Printed Circuits: IPC-2221 Generic Standard on Printed Board Design

2.3.7 Society of Automotive Engineers.

SAE-AS25050 Colors, Aeronautical Lights and Lighting Equipment, General Requirements For

2.3.8 Underwriters Laboratories Inc:

9/30/2008

FAA-E-3007

UL 1059	Terminal Blocks
UL 489	Molded case circuit breakers and circuit-breaker enclosures.

(Copies of applicable FAA specifications, standards, and drawings may be obtained from the Contracting Officer in the Federal Aviation Administration office issuing the SIR, IFB, or contract involved, or other use to be made of the requested material.)

(Single copies of military specifications and standards may be obtained from the Federal Aviation Administration, Washington, D.C. 20590, ATTN: Contracting Officer. Requests should cite the invitation for bids, RFPs, or contract for which the material is needed. Mail requests, if found acceptable, will be forwarded to a military source of supply for filling; hence, ample time should be allowed. Single copies of military specifications, standards, and publications may also be obtained directly from the Commanding Officer, Naval Publications and Forms Center, 5801 Tabor Avenue, Philadelphia, PA 19120.)

(Information on obtaining Federal specifications and standards may be obtained from General Services Administration offices in Washington, D.C.; Atlanta; Boston; Chicago; Denver; Kansas City, Missouri; New York; San Francisco; and Seattle.)

(Information on obtaining NEMA standards may be obtained from the National Electrical Manufacturers Association, 155 East 44th Street, New York, NY 10017.)

(Copies of ANSI standards may be obtained from the American National Standards Institute, 70 East 45th Street, New York, NY 10017.)

(Information on obtaining the National Electrical Code may be obtained from the National Fire Protection Association, Battery March Park, Quincy, MA 02269.)

(Information on Master Painter's Institute specifications can be found at:
<http://www.paintinfo.com/mpinfo/guide/index.htm>.)

(Information on American Society for Testing and Materials Specifications may be obtained from ASTM International, 100 Barr Harbor Drive, PO Box C700, West Conshohocken, PA, 19428-2959)

(Information on Institute for Printed Circuits Specifications may be obtained from IPC-Association Connecting Electronics Industries, 3000 Lakeside Drive, 309S, Bannockburn, IL, 60015.)

(Information on Society of Automotive Engineers Standards may be obtained from SAE Customer Service, 400 Commonwealth Drive, Warrendale, PA, 15096-001.)

(Information on Underwriter's Laboratories Standards can be obtained from COMM2000, 1414 Brook Drive, Downers Grove, IL, 60515.)

9/30/2008

FAA-E-3007

3. REQUIREMENTS.

3.1 General Functional Requirements. The PAPI will be installed alongside a runway to provide accurate visual approach path information to pilots of landing aircraft, either day or night. The PAPI shall meet the requirements specified herein, and shall consist of:

- a) Four LHAs, with integral mounting and adjustment hardware
- b) One PCA
- c) One aiming instrument set (not required for systems with built-in electronic clinometers).

The PAPI signal presentations are shown in Figure 1 and a typical PAPI approach path (side view) is shown in Figure 2.

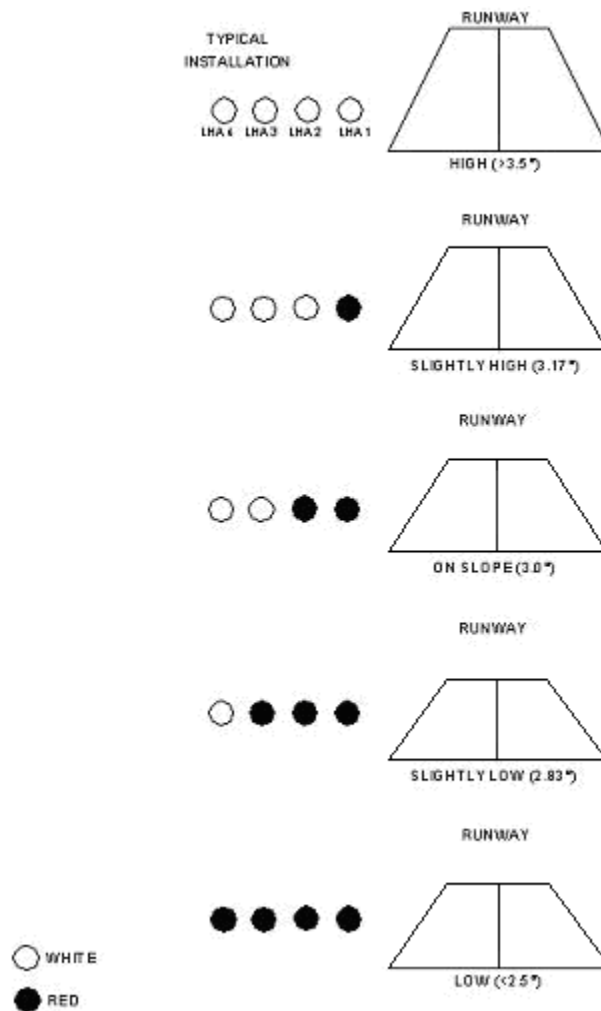

Figure 1. PAPI Signal Presentations

9/30/2008

FAA-E-3007

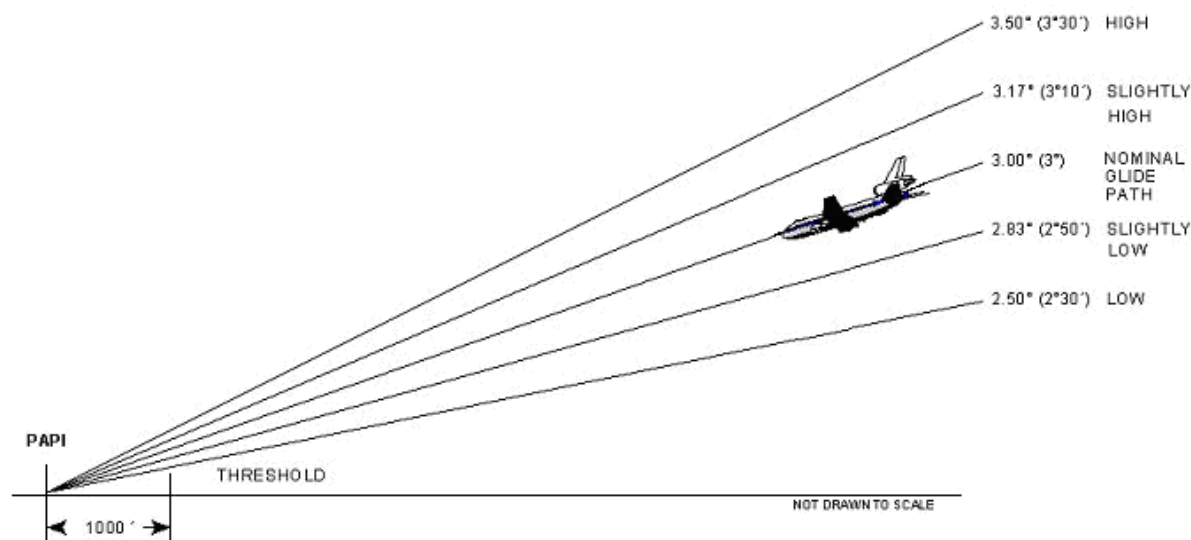

Figure 2. PAPI Approach Path (Side View)

3.2 Photometric Requirements.

3.2.1 Light Beam. Each PAPI LHA shall provide a split beam of light consisting of white light in the top sector and red light in the bottom sector as viewed from the front. The transition from red light to white light shall occur within an angle of 3 minutes of arc at the beam center and within an angle of 5 minutes of arc at the beam edges. The transition band shall be flat to within 3 minutes of arc. The PAPI shall provide usable visual approach guidance out to ± 10 degrees either side of the extended runway centerline.

3.2.2 Light Intensity. The PAPI shall provide guidance at two light intensity steps. Day mode operations shall be defined as the minimum values shown in Figure 3. Night mode operations shall be defined as 10 percent of the values shown in Figure 3.

6/16/2009

FAA-E-3007 W/ Change 1

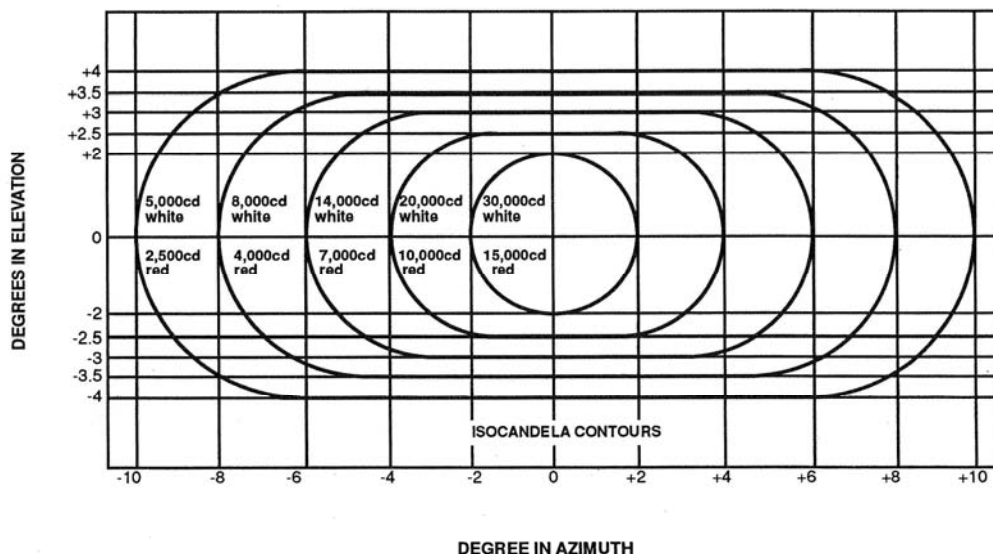

Figure 3. Light Intensity Requirements for PAPI

3.2.3 Light Colors. The white light shall be generated by LEDs having a color temperature of 4500K to 10,000K. The red light shall be generated by LEDs having a spectral output between 620.5nm and 645nm.

3.2.4 Light Beam Aiming Tolerance. The centerline of the transition zone (i.e., the vertical area of change from red light to white light) of each LHA projected light signal shall be parallel to the zero aiming angle projection within ± 5 minutes of arc. This means that the projected vertical transition zone signal angle will be coincident with the LHA aiming angle, whether measured by internal or external means, to the tolerance stated, and is a measure of the aiming accuracy of the LHA/aiming device combination.

3.3 Sub-assemblies.

3.3.1 Lamp Housing Assembly.

3.3.1.1 Lamp Housing Assembly General. The LHA shall use LEDs as the light-producing elements. An example of an LHA that uses three projection lenses and aiming pad for a clinometer is shown in Figure 4. The LHA shall consist of:

- a) An optical bench that will permit the mounting LEDs, projection lenses, and the required adjustment hardware.
- b) A removable housing shell, integral with a deflection plate (Figure 4)
- c) A tilt fault detection system consisting of either a tilt switch assembly or built-in solid-state clinometer to supply tilt readings to indicate a deviation from the proper

9/30/2008

FAA-E-3007

leveling and therefore not providing the proper glide slope guidance. More detail is provided in 3.3.1.4.4.

- d) An aiming pad and a transverse leveling pad if the LHA is to be leveled and aimed using an external clinometer. The aiming pad and leveling pad are to be an integral part of the optical bench, made in such a manner that the clinometer may be placed on the the aiming pad and leveling pad without opening or removing the LHA housing shell. They are to meet the requirements of 3.2.4
- e) A thermostatically controlled heater to prevent ice formation on the lenses.

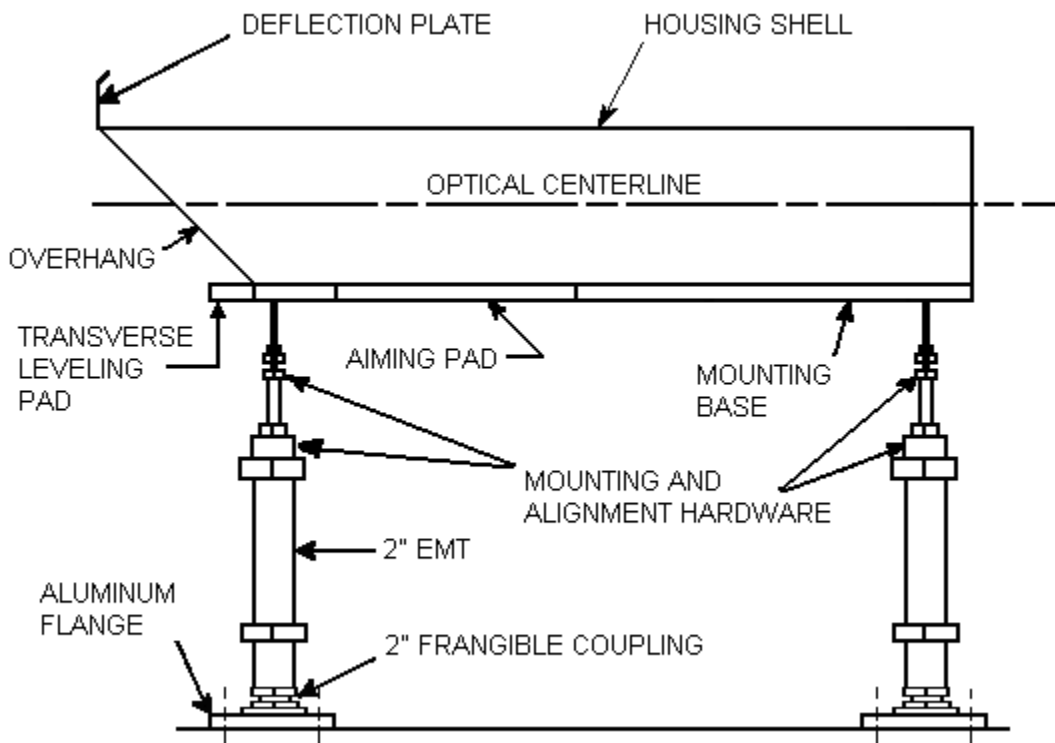

Figure 4. Lamp Housing Assembly Side View (Typical – For illustration only)

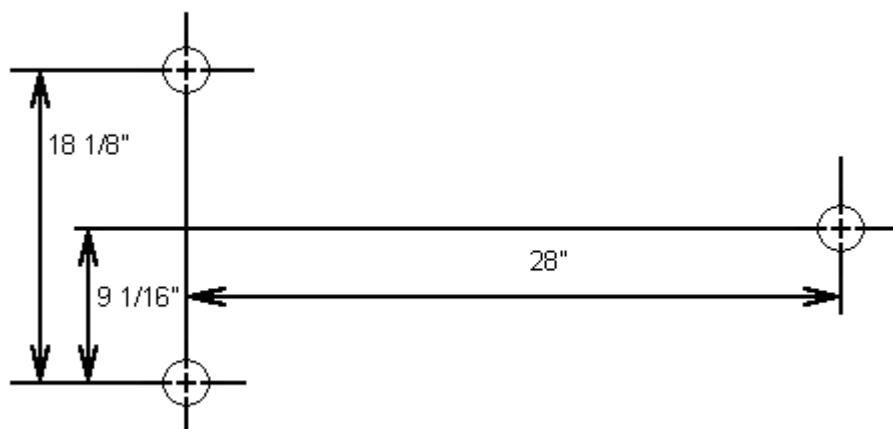

Figure 5. LHA mounting pad.

3.3.1.2 Lamp Housing Assembly Operational Requirements.

3.3.1.2.1 Optical. The LHA shall be designed to maintain the required light beam orientation and photometric requirements in accordance with section 3.2 performing under the environmental conditions specified in section 3.9.

3.3.1.2.2 Control and Status. Upon receiving the appropriate command from the PCA, the LHA shall operate in either night mode or day mode. The default mode for an LHA absent of any LHA command, shall be non-illuminated. The LHA shall report status information back to the PCA. As a minimum this information shall include: the mode that it is in (Day/Night); whether the light output is low or in tolerance for the selected mode; and whether a tilt fault condition exists (or angle information from a solid-state clinometer for interpretation by the PCA). The control and status signals shall be implemented by discrete signals, a serial wire link, or a fiber-optic link. Use of a wireless communication link between the PCA and the LHAs is not permitted.

3.3.1.2.3 Weight. In accordance with MIL-STD-1472F section 5.9.11.3, the weight of the LHA, excluding mounting legs, shall not be greater than 100 pounds (45.5 kilograms (kg)). This must be in accordance with MIL-STD-1472 section 5.9.11.3.

3.3.1.2.4 LED-out Feature. The LHA shall be considered to be unserviceable if greater than 25 percent of either the red or white LEDs have failed. The LHA shall also be considered to be unserviceable if the light output is less than the values stated in 3.2.2. for the selected mode (day or night). If either of these two conditions is present, a signal shall be generated and sent to the PCA reporting the condition such that the PCA can turn off the LEDs.

3.3.1.3 Lamp Housing Assembly Enclosure

3.3.1.3.1 Optical Bench.

9/30/2008

FAA-E-3007

3.3.1.3.1.1 The optical bench shall be constructed of corrosion resistant metal and shall, in conjunction with the structural design, provide rigidity to maintain the required optical alignment when subjected to a load of 15 lbs per square foot (73 kilograms per square meter). The mounting base is that part of the LHA to which the subassemblies attach to. The mounting base and optical bench may be combined as a single integrated unit.

3.3.1.3.1.2 The maximum dimension of any drain hole (if required) shall be not greater than 1/16 inch (1.57 millimeters (mm)) in diameter to prevent intrusion of foreign objects.

3.3.1.3.1.3 If an internal clinometer is not used, then a transverse leveling pad and aiming pad compatible with the clinometer specified in section 3.3.3 shall be an integral part of the LHA and accessible on the outside of the LHA without opening any LHA covers or the housing shell. The tolerance for the flatness of the pads shall be $\leq .005$ inches.

3.3.1.3.1.4 If an internal clinometer is used, a means must be provided to read it without opening any LHA covers or the housing shell.

3.3.1.3.2 Housing Shell.

3.3.1.3.2.1 The optical bench shall be enclosed by a housing shell made of inherently corrosion resistant metal. Removal or pivoting of the housing shell shall permit easy access to the internal components mounted on the optical bench. The housing shell shall be installed on the mounting base (see Figure 4) by means of threaded. The housing shell shall overlap the sides of the unit and be fastened in such a manner that rain will not enter the unit if the gaskets fail or if fasteners are lost. The housing shell shall include an integral deflection plate on the top front edge to prevent the pilot from seeing light reflected off the back of the LHAs. The integral deflection plate shall have a minimum height of 7 percent of the length of the housing shell (adequate protection up to 4 degrees above flight path).

3.3.1.3.2.2 All points that have electrical potentials in excess of 70 VDC or 50 VAC shall be shielded by guards or barriers to prevent accidental contact by a service technician. The LHA shall be provided with an interlock to disable power when the housing shell is opened. Interlocks, if used, shall include a mechanical override. In addition, closure of the housing shall either reset the override or shall be prohibited if the override is active.

3.3.1.3.3 Power Input Cable and Signal Cable Entrance.

3.3.1.3.3.1 Space shall be reserved in the rear of the LHA to permit connection of the incoming cables to the terminal blocks. The power cables shall enter through one hole located in the bottom rear of the housing. The control and status signals cable (or fiber) shall enter through another hole located in the bottom rear of the housing. The earth ground wire shall be brought in through a separate hole from the power or signal wires. The holes shall be sized to allow the installation of strain relief connectors for liquid tight flexible conduit of 1 inch (30.2mm).

3.3.1.3.3.2 A separate ground lug shall be provided for earth ground. The ground lug shall have a slotted, green-colored head suitable for a No. 6 American Wire Gauge bare copper ground wire. A hole of up to 1/2 inch (12.7 mm) diameter shall be provided in the bottom of

9/30/2008

FAA-E-3007

the LHA near the wire entrance holes. The purpose of this hole is to provide a place to anchor a pull cable or cables that will link the LHA to frangible connectors at the LHA foundation, so as to guarantee breakaway of the connector before wires are pulled out.

3.3.1.3.4 Mounting Provisions.

3.3.1.3.4.1 The LHA shall be designed for installation on a concrete foundation using the footprint shown in Figure 5. The mounting base shall have three adjustable legs to permit aiming of the light beam to any vertical angle from 1.5 degrees up to 6 degrees. Also, the mounting and adjustment hardware shall permit transverse leveling where any mounting leg may be up to 1 inch (2.54 cm) higher or lower than any other leg after installation.

3.3.1.3.4.2 The legs will consist of mounting and adjusting hardware, 2-inch electrical metallic tubing (emt), frangible couplings conforming to FAA Drawing C-6046, and aluminum flange; these components are supplied separately and are not part of this PAPI specification.

3.3.1.3.4.3 The attachments to the mounting base shall be designed in such a way that aiming may be accomplished without opening the LHA. The leg attachments to the mounting base shall not create any stress on the mounting base at any angle from 0 to 6 degrees. In addition, the leg attachments shall be designed to bend or fold over without damaging the mounting base if the unit is forcibly dislodged from the frangible couplings.

3.3.1.4 LHA Components.

3.3.1.4.1 LEDs.

3.3.1.4.1.1 LEDs shall be used to produce the white and red portions of the beam without a filter element. The LEDs shall have a rated life of 50,000 hours or more when operated at day mode intensity. The LED drivers shall have enough range to produce the light levels required in 3.2.2 over the entire lifespan of the LEDs. A means shall be provided to automatically adjust the light intensity over the lifespan of the system to maintain the minimum required light levels of 3.2.2.

3.3.1.4.1.2 The LHA shall use LED modules or individual LEDs that can be replaced at the field level to restore the LHA to normal operation. An array may be repairable at either a field or depot level. If an array is used, the LEDs must be connected such that a single LED failure will not produce an axial failure.

3.3.1.4.1.3 The LED mounting shall permit firm and positive positioning of the LEDs. The mounting shall be designed to facilitate removal and replacement to meet the required Mean Time To Repair (MTTR) in accordance with section 3.18.1(a). Replacing LEDs or LED modules shall not require optical realignment.

3.3.1.4.1.4 The method of controlling the intensity shall not decrease the life expectancy of the LEDs. Any method used to modulate the intensity of the LEDs shall not produce any visible "strobe effects" (i.e., modulated at a rate <120Hz) when viewed at a distance greater than 100 feet (30.3 meters).

9/30/2008

FAA-E-3007

3.3.1.4.2 Projection Lens. The glass projection lenses shall be mounted in a vertical frame or frames made inherently corrosion resistant metal which may be an integral part of the optical bench. Light, including direct sunlight, entering the LHA through the lenses shall not cause any damage to the LHA. The lenses shall be recessed under an overhang to minimize the direct impingement or splash-back of rain or snow on the lenses, and the overhang shall protrude beyond the front of the unit by a distance equal to or greater than the height of the housing shell.

3.3.1.4.3 Terminal Blocks

3.3.1.4.3.1 Terminal blocks shall be provided in the rear of the LHA for all electrical interfaces to the LHA. Power connections and control and status signals shall be on different terminal blocks that are clearly labeled for each purpose.

3.3.1.4.3.2 Either enclosed base type or DIN rail type terminal blocks shall be used. Terminal blocks shall provide inherently corrosion resistant terminals rated to carry 150% of expected current at 250 VAC. In addition, the terminal blocks shall satisfy the dielectric strength requirements of 3.12.

3.3.1.4.3.3 Electrical contact surfaces of terminals shall be brass, bronze, copper, or stainless steel which satisfies UL 1059 Standard. Pressure screws of the electrical terminals shall be brass, bronze, or stainless steel that satisfy UL 1059 standard. Each pressure-type terminal shall be equipped with a pressure plate to prevent the tip of the screw from turning directly on the wire. The separators shall prevent current leakage under the environmental conditions specified in 3.9.

3.3.1.4.3.4 The terminal blocks shall accommodate all internal connections and external cable connections using a dedicated terminal for each conductor. External connections will be made using conductors ranging in size from No. 12 AWG to No. 8 AWG for power wiring and No. 18 or No. 20 AWG for signal wiring. Markings shall be provided in accordance with 3.13.3.

3.3.1.4.4 Tilt Switch or Tilt Indicator.

3.3.1.4.4.1 Each LHA unit shall have a tilt detection system that may consist of either a tilt switch or a built-in solid-state clinometer to determine if the LHA has deviated from its set aiming angle. If a tilt switch is used, it shall be of a non-mechanical design that will meet the vibration requirements in accordance with section 4.5.10. A solid-state clinometer may also be used to measure the aiming angle and transverse level of the LHA in order to determine if a tilt condition has occurred. If a solid-state clinometer is used, there shall be a display internal to the LHA to display the aiming angle and transverse level. In addition, if a solid state clinometer is used to measure and display aiming and transverse angle, a means shall be provided to calibrate the device at the depot level.

3.3.1.4.4.2 The tilt fault detection system shall de-energize the LEDs when the optical pattern is lowered between 1/4 and 1/2 degree or raised between 1/2 and 1 degree with respect to the preset aiming angle. The tilt fault detection system shall have a time delay of at least 10 seconds that will prevent intermittent tilt indication due to vibration. The tilt fault

9/30/2008

FAA-E-3007

detection system shall have failsafe operation so that any malfunction of the tilt switch or solid-state clinometer, including loss of input power, shall de-energize the LEDs in all LHAs.

3.3.1.4.5 Power supplies. Power supplies for the LEDs shall drive the LEDs at the levels specified in 3.2.2. The power supply and all associated wiring shall be designed to withstand the dielectric requirement in accordance with 3.12.

3.3.1.4.3 Heater. The LHA shall be provided with a thermostatically controller heater to prevent the formation of ice on the lenses in accordance with 3.9.10.

3.3.1.5 LHA Finish.

3.3.1.5.1 Housing Shell Finish. All exterior and interior surfaces of the lamp housing shell shall be finished in accordance with 3.8.1 using the colors specified in this section.

3.3.1.5.2 Interior Finish. The deflection plate front surface and all interior surfaces of the housing shell, including the interior surface of the overhang, shall be painted black, color No. 37038 of FED-STD-595.

3.3.1.5.3 Exterior Finish. All exterior surfaces of the housing shell including the back surface of the deflection plate, shall be painted International Orange, color No. 12197 of FED-STD-595.

3.3.1.5.4 Optical Bench Finish. The optical bench including the projector mounting frames, shall be painted in accordance with 3.8.1, with black, color No. 37038 of FED-STD-595, or as an alternative, black anodized per MIL-A-8625 in lieu of painting.

3.3.1.5.5 Mounting Base Finish. The LHA mounting base shall be painted in accordance with 3.8.1, with black, Color No. 37038 of FED-STD-595, or alternatively, black anodized per MIL-A-8625 in lieu of painting.

3.3.2 Power and Control Assembly.

3.3.2.1 Power and Control Assembly General. The PCA shall control the power to the LHAs. The PCA shall issue commands to the LHAs to go to night mode or day mode. The PCA shall receive status back from the LHAs, as a minimum the mode that it is in; "light output low" for the selected mode; and tilt angle information or tilt fault status. The control and status signals may be implemented by discrete signals, a serial wire link, or a fiber-optic link. The PCA shall form one unit that is intended to be installed adjacent to the LHA furthest from the runway. The weight of the PCA shall not exceed 50 pounds (22.67 kg). No external cooling shall be required.

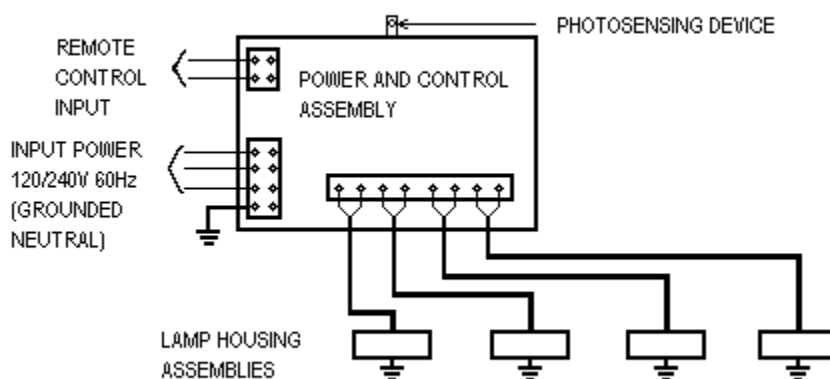

Figure 6. Functional Relationship of PAPI Units. Electrical interconnections between the PCA and the four LHAs is dependent on the design (for illustration only)

3.3.2.2 PCA Operational Requirements.

3.3.2.2.1 Purpose. The PCA shall supply power for operation of the PAPI. When the system is powered up, the PCA shall command the LHAs to illuminate at night intensity, and then if sufficient light is present, command the LHAs to illuminate at day intensity.

3.3.2.2.2 Modes. The ON/OFF operation of the PAPI shall be controlled by a three position switch: REMOTE, LOCAL, or OFF. The switch shall select an operation as follows: REMOTE allows the remote control input signal (120 VAC, 60Hz) to turn the LHA LEDs on or off; LOCAL turns the LHA LEDs on; and OFF turn the LHA LEDs off. In both the Remote and the LOCAL positions, the PAPI shall illuminate the LHAs if no fault conditions are detected or shut down the system if faults are detected.

3.3.2.2.3 Input Power. The 120/240 volt, 60 Hz input power lines (with Neutral grounded in accordance with National Electric Code) shall terminate at the power terminal block (3.3.2.4.1), and shall be connected to internal circuitry of the PCA through a two-pole main circuit breaker (3.3.2.4.2). The system shall have a maximum power consumption of 1.5 KW including any heaters. Circuit breakers shall be used to protect any power feeds from the PCA to the LHAs. Total Harmonic Distortion of the input voltage waveform shall be not more than 5 percent. The system shall recover automatically (or continue to operate) from momentary power interruptions and brownout conditions where the input voltage dips more than 10 percent below nominal. The PCA shall include a 120 VAC Ground Fault Interrupt duplex outlet for connecting maintenance and service equipment. The PCA shall include a service lamp, protected by a fuse or circuit breaker, for illuminating the interior of the PCA cabinet during service operations.

3.3.2.2.4 Fault Conditions. The PCA shall shut down the PAPI if any of the following events are present for at least 10 seconds: any LHA stays in day mode when night mode is selected, an LED out condition as defined in 3.3.1.2.4 occurs, or a tilt fault condition as described in 3.3.1.4.4.2 is detected in an LHA. Loss of communication from any LHA for more than 10 seconds or an LHA not responding to a command to shut down (neither night

9/30/2008

FAA-E-3007

nor day mode active) shall cause the PCA to shut down power to the LHAs. LED indicators or a display inside the PCA shall indicate the initial cause of a system shutdown. If a microprocessor or microcontroller is utilized, a watchdog timer circuit shall be employed to detect a software lockup condition and cause a hardware reset to be issued to the system.

3.3.2.2.5 Remote Monitoring System (RMS). External signals shall be provided for use by an optional RMS in accordance with section 3.4.1.

3.3.2.2.6 Remote Control Input. A Remote Control Input shall be provided to control the PAPI when the main switch is set to the REMOTE position. 120 VAC \pm 10 percent applied to the input shall turn the system on and lack of input shall turn the system OFF. The Remote Control Input connections shall withstand the dielectric requirements in accordance with 3.12.

3.3.2.3 Power and Control Assembly Cabinet.

3.3.2.3.1 Cabinet Configuration. The PCA cabinet shall contain all the PCA components (3.3.2.4) in one single enclosure, including terminal blocks, cable clamps, grounding lugs, and protective devices. The cabinet shall be an outdoor, liquid-tight, National Electrical Manufacturers Association (NEMA-4X) type enclosure. All plane surfaces of the control cabinet shall intersect at 90 degrees. Access to the interior of the cabinet shall be provided through one hinged door with gasket with provision for padlocking. The padlock hasp shall have a 7/16 inch (11.1 mm) hole. The door shall open a minimum of 110 degrees and shall be equipped with a latching mechanism to hold the door in the open position. The internal face portion of the door shall display a system wiring diagram. The door of the cabinet shall be bonded to the body of the cabinet in accordance with National Electric Code (NEC) Article 250-90 (2002).

3.3.2.3.2 Internal Components. All components except the photo sensing device (3.3.2.4.4) shall be contained inside the cabinet. There shall be no other devices protruding through the walls of the cabinet. Electronic components shall be mounted on plug-in printed wiring boards or flat mounted printed wiring boards with pluggable connectors in accordance with 3.5.2. All adjustments located on printed wiring boards shall be readily accessible to the operator. Adjustments shall be made without the need to use extender cards or cables.

3.3.2.3.3 Internal Wiring. Proper high-temperature wire in accordance with National Electric Code Article 310 (see Tables 310-13 and 310-61) shall be used throughout the cabinet. Space shall be provided in the bottom of the cabinet for all wiring (input, output, and internal) and for all terminal blocks. An internal ground lug shall be provided in the cabinet for grounding purposes. The ground lug shall have a slotted, green-colored head suitable for a No. 6 American Wire Gauge bare copper ground wire.

3.3.2.3.4 High Voltages. All points that have electrical potentials in excess of 70 VDC or 50 VAC shall be shielded by guards or barriers to prevent accidental contact by a service technician. The PCA shall be provided with an interlock to disable power when the door is opened. Interlocks shall include a mechanical override. In addition, closure of the door shall either reset the override or shall be prohibited if the override is active.

3.3.2.4 PCA Components.

3.3.2.4.1 Terminal Blocks. One input terminal block of the enclosed base type or DIN rail type, with three screw-pressure terminals, shall be provided for the primary power. For the LHA connections, power connections shall be located on one or more terminal blocks and control and status signals shall be located on different terminal blocks of the enclosed base type or DIN rail type. Terminal blocks shall provide inherently corrosion resistant terminals rated to carry 150% of expected current at 250 VAC. Electrical contact surfaces of terminals shall be brass, bronze, copper, or stainless steel that satisfy UL 1059 standard. Pressure screws of the electrical terminals shall be brass, bronze, or stainless steel that satisfy UL 1059 standard. Each pressure-type terminal shall be equipped with a pressure plate to prevent the tip of the screw from turning directly on the wire. The separators shall prevent current leakage under the environmental conditions specified in 3.9. The terminal blocks shall have a dedicated terminal for each conductor, for all internal connections, plus connection of external power cables. External connections shall be made using conductors ranging in size from No. 12 AWG to No. 8 AWG for power wiring and No. 18 or No. 20 AWG for signal wiring. Marking shall be provided in accordance with 3.13.3.

3.3.2.4.2 Circuit Breaker. A two-pole, molded-case, Thermal-magnetic circuit breaker or electronic solid state type shall be provided as a main circuit breaker and power switch. The circuit breaker shall have an arc quenching chamber and shall have a minimum rating of Asymmetrical interrupting capacity (AIC) of 10,000 A (10KA) at 250V, 60Hz as rated by Underwriters Laboratories Standard UL 489.

3.3.2.4.3 Photoelectric Switching Circuitry. A photoelectric switching circuit shall be provided to automatically change the intensity of the lights in two steps as described below. All operating components of the switching circuitry, except the photo sensing device (3.3.2.4.4) and any associated signal conditioning circuitry, shall be mounted on a printed wiring board mounted within the cabinet. The photoelectric switching circuit shall cause the PCA to set the LHA output to high when the illumination on a vertical surface facing north reaches 58 ± 2 foot-candles (624 ± 21.5 lux), and shall set the LHA output to LOW when the illumination falls to 35 ± 2 foot-candles (377 ± 21.5 lux). The on-off points shall vary not greater than ± 2 foot-candles (± 21.5 lux), at any ambient temperature in the range specified in 3.9.1 with line-to-line voltage variations from 230V to 250V. Similarly, the on-off points shall vary not greater than 3 foot-candles (32.28 lux) with line-to-line voltage variations from 216V to 230V and from 250V to 264V. A symmetrical time delay of 5 to 8 seconds shall be provided to prevent the output current from changing due to transient light conditions. A fail-safe feature shall set the output level to the low (night) setting in the event the photo sensing device fails. The circuit shall also drive the elapsed time indicator (3.3.2.4.6) when the output is set to HIGH (day) mode.

3.3.2.4.4 Photo sensing Device. The photo sensing device shall be mounted on the top surface of the PCA cabinet and shall be able to be rotated in any direction so as to point to North and to lock in that position. The photo sensing device shall be equipped with a thermostatically controlled heater to prevent the formation of ice on the lens under all temperature conditions specified for the system. The photo sensing device shall be mounted in such a way that it will remain clear of up to 6 inches (15.25 cm) of snow accumulated on top of the PCA cabinet. The device itself shall be hermetically sealed, and shall have a spectral response that peaks in the 5500 - 6000 angstroms (0.021 - 0.023 mil) region. The

9/30/2008

FAA-E-3007

device shall meet the temperature requirements of the photoelectric switching circuitry (3.3.2.4.3). The device shall activate the photoelectric switching circuitry (3.3.2.4.3).

3.3.2.4.5 Power Supply. A power supply shall be provided to supply the proper voltages and currents necessary to operate the PCA circuits within the tolerances and conditions set forth in this specification. Wherever practicable, all electronic components shall be mounted on a plug-in printed wiring board mounted within the cabinet. The power supply and all associated wiring shall be designed to withstand the dielectric requirements in accordance with 3.12.

3.3.2.4.6 Elapsed Time Indicator. An elapsed time indicator shall be provided to register the number of hours of operation during the high-intensity setting. The meter shall indicate total time in hours and tenths of hours. The meter shall be recyclable and shall have a minimum indicator range of 50,000 hours. The meter shall be mounted within the cabinet.

3.3.2.5 Power and Control Assembly Finish. All exterior and interior surfaces of the PCA shall be finished as described in 3.8.1, with Aviation White, Color No. 17875 (in accordance with FED-STD-595) except that aluminum surfaces that are clear anodized in accordance with MIL-A-8625, Type II do not require painting.

3.3.3 Aiming Instrument Set and Calibration Bar. An aiming instrument set is required for a PAPI that is aimed by external means. A PAPI using internal clinometers to determine aiming does not require an aiming instrument set. The Aiming Instrument Set shall consist of a clinometer, a calibration bar, and a portable storage case.

3.3.3.1 Clinometer. The clinometer shall be used to accurately adjust the LHA during cross-leveling (lateral), longitudinal leveling, and elevation setting.

3.3.3.1.1 Construction. The base of the clinometer shall be rustproof. The clinometer shall be constructed of inherently corrosion resistant metal to provide a 10 lbs. (4.5kg) maximum rugged instrument. Aluminum and other soft metals shall not be used where subject to metal-to-metal rubbing. Design and construction of the clinometer shall be such that deviation from true position due to its own weight shall be not greater than 3 minutes of arc when the clinometer is placed on the optical bench (3.3.1.3.1.3). The clinometer shall be designed so that repeated changing of the dial setting will not cause excessive wear that could deteriorate the accuracy of the instrument.

3.3.3.1.2 Level. The clinometer shall utilize a 6-inch (15.24 cm) (maximum) level having an accuracy of ± 2 minutes. The level shall be permanently attached to the clinometer to permit fine adjustments to calibrate the instrument. The level shall have a protective device to minimize possible damage.

3.3.3.1.3 Dial. An accurate direct-reading dial or micrometer type indicator shall be provided for setting the LHA to the desired angle. The reading dial shall indicate at minimum, angles from 1.5 degrees to 6 degrees in graduated increments of minutes of arc. The spacing between each degree mark shall be at least 1/2 inch (12.7 mm). A 0.00 degree setting shall be provided on the dial for calibration purposes and shall have an accuracy of ± 2 minutes of arc and a repeatability of ± 1 minute of arc while on the calibration bar. Alternate designs using a vernier dial may be used, so long as the vernier dial is provided with

9/30/2008

FAA-E-3007

equivalent graduations as specified for the direct reading dial. The clinometer shall have provisions for firmly securing the dial setting after factory calibration, but shall permit field adjustment to the 0.00 degree position by the user.

3.3.3.2 Calibration Bar. A calibration bar shall be provided with each clinometer to permit field checking and calibration. The calibration bar shall be designed for laying on a flat surface or in the carrying case (see 3.3.3.3) and shall have adjustment features to permit it being leveled to a horizontal plane. The tolerance for the flatness of the calibration bar shall be ≤ 0.005 inches. A portable level, not attached to the bar, shall be provided with each calibration bar to permit leveling. The level shall have a metal base meeting the requirements of 3.6.1. The level shall be used to set up the calibration bar and verify the calibration of the clinometer.

3.3.3.3 Carrying and Storage Case. A rigid portable inherently corrosion resistant metal, fiberglass, or shatterproof plastic case shall be provided for carrying and storing the clinometer. The case shall have a carrying handle and shall have a suitable latch for securing the cover in the closed position. The interior shall be designed to accommodate the clinometer so that it will be held and cushioned firmly in place. The case shall also carry and store the calibration bar and portable level. The aiming instrument set carrying case shall have an instruction plate installed on the inside of the cover in a location easily viewed by the user and shall contain all necessary instructions for calibration and use of the aiming instrument set. The instruction plate shall be made of aluminum. The plate shall conform to the requirements of 3.6.5.

3.4 Monitored Points and Controls. Test points shall be provided on all signals required to be monitored during checkouts, alignment, and calibration, or during preventive maintenance procedures. Test points shall not be located in compartments with voltage points of 500 volts or more, and all test points shall be located so as to preclude accidental shock to personnel engaged in normal operating or maintenance activities. The removal of components, modules, or circuit cards shall not be required to gain access to test points or adjustments. Test point controls and indicators mounted on printed wiring boards installed in a card cage shall be accessible from the front of the circuit cage assembly without the use of extender boards.

3.4.1 External signals Monitored items/test points shall be brought out to a port on a card or backplane for possible connection to a future Remote Monitoring System (RMS). Tables I and II below give examples of signals that may be found on a PAPI system. These signals are not subject to the dielectric requirements in accordance with 3.12.

Table I, PAPI monitored points, LHA origin (monitored at PCA)		
SIGNAL	DEFINITION	SIGNAL TYPE
1TLT	TILT FAULT OUTPUT ON LHA 1	Status
1L01	LED OUT OUTPUT ON LHA 1	Status
LHA #1 power OK	Indicates that LHA 1 Power Supply is operating properly	Status
LHA 1 OUT OF TOLERANCE	Indicates that the LEDs are too dim for the selected mode	Status

9/30/2008

FAA-E-3007

2TLT	TILT SWITCH OUTPUT ON LHA 2	Status
2L01	LED FAULT OUTPUT ON LHA 2	Status
LHA #2 power OK	Indicates that LHA 2 Power Supply is operating properly	Status
LHA 2 OUT OF TOLERANCE	Indicates that the LEDs are too dim for the selected mode	Status
3TLT	TILT SWITCH OUTPUT ON LHA 3	Status
3L01	LED FAULT OUTPUT ON LHA 3	Status
LHA #3 power OK	Indicates that LHA Power Supply is operating properly	Status
LHA 3 OUT OF TOLERANCE	Indicates that the LEDs are too dim for the selected mode	Status
4TLT	TILT SWITCH OUTPUT ON LHA 4	Status
4L01	LED FAULT OUTPUT ON LHA 4	Status
LHA #4 power OK	Indicates that LHA Power Supply is operating properly	Status
LHA 4 OUT OF TOLERANCE	Indicates that the LEDs are too dim for the selected mode	Status
GND	GROUND OUTPUT	

Table II, PAPI monitored points, PCA origin

SIGNAL	DEFINITION	SIGNAL TYPE
REMOTE ON	REMOTE ON FOR NORMAL MODE. This is a signal that is used to turn the PAPI on remotely	Status
PHOTORE SLO	Output of the photocell. This may vary according to the design	Monitor point
DAY	Indicates if the PAPI is in day or night mode	Status
TILT	TILT CONDITION SHUTDOWN. Indicates if the system is shut down due to a tilt condition	Status
OUT OF TOLERANCE	Indicates that a shutdown has occurred due to the LEDs being too dim for the selected mode.	Status
POWER ON	A DC signal that indicates the PAPI system is powered up	Status
LAMPS ON	A DC signal that indicates that the LHAs are illuminated	Status
PS VOLTAGE	One monitoring point for each power supply voltage present in the PCA	Monitoring point
Generate Power On Reset	Connecting this signal to power ground causes a power on reset condition	Control
ANLG GND	ANALOG GROUND	Reference point
PW GND	POWER GROUND	Reference point

9/30/2008

FAA-E-3007

3.5 Electrical Components. Electrical components must meet the requirements specified herein unless otherwise noted.

3.5.1 Electrical Connectors. Electrical connectors shall be in accordance with FAA-G-2100 section 3.3.1.3.3.

3.5.2 Printed Wiring Boards. Printed wiring boards, assemblies and components mountings shall conform to FAA-G-2100, paragraphs 3.2.2.1 and 3.2.2.2, with the exception of paper base copper-clad laminates, which are prohibited. Conformal coating is required and shall be in accordance with FAA-G-2100 paragraph 3.3.1.3.7b.

3.5.3 Component Ratings. When component ratings are not specified, they shall be selected to ensure that the components are not operated in excess of 80 percent of their normally de-rated maximum values for the temperatures encountered under the specified equipment environmental conditions. De-rating of electronic components shall be in accordance with MIL-STD-454, Requirement 18.

3.5.4 Fiber Optics. Any fiber optics used in the PAPI shall conform to FAA-STD-049.

3.6 Materials and parts. Materials and parts shall be as specified herein. Materials and parts not specifically designated by a standard or specification shall meet the requirements of FAA-G-2100 section 3.3.1. All materials and parts shall be suitable for operation under the environmental conditions in accordance with 3.9.

3.6.1 Metals. Metals shall be inherently corrosion resistant. The use of dissimilar metals shall be in accordance with MIL-STD-889 section 5.1. Parts may be suitably coated to prevent seizing of parts that require removal for servicing.

3.6.2 Aluminum. Aluminum shall be in accordance with American Society for Testing and Materials (ASTM) B241, B221, and B211. Aluminum alloy plate and sheet, aluminum alloy die castings, and aluminum alloy sand castings shall be in accordance with ASTM B209, B26, B108, and B85.

3.6.3 Optical covers. Light transmitting covers shall be free of bubbles.

3.6.4 Gaskets. Gaskets used at separable joints for cushioning and sealing purposes shall be made of neoprene and shall be suitable for use at temperatures of -67°F (-55°C) to +149°F (+ 65°C). Note: this range exceeds the operating requirements in order to cover possible storage conditions.

3.6.5 Nameplates. Nameplates conforming to FAA-E-2100 paragraph 3.3.3.1 shall be installed at convenient locations on the LHA, the power and the control assembly, and the clinometer carrying and storage case, if applicable. Each nameplate shall be attached to each assembly with four aluminum rivets or drive screws.

3.7 Interchangeability. All parts of the unit furnished under a single procurement shall be manufactured to a tolerance that shall permit interchangeability of any part with like part of any other unit. Identical components shall be identified with identical parts numbers and

9/30/2008

FAA-E-3007

unlike parts shall not have the same part number. This requirement does not prevent the readjustment or calibration of exchanged modules nor does it prohibit exchange of control panels due to the runway identification number. Interchangeability shall be in accordance with MIL-HDBK-454, Requirement 7.

3.8 Finishes.

3.8.1 Paint. All aluminum exterior and interior surfaces shall be pretreated with a chemical film in accordance with MIL-C-5541, Class 1A or MIL-STD 8625, and shall be sprayed with one coat of zinc chromate primer in accordance with Federal Specification No. TT-P-1757, composition L, color Y. Alternatively, the housing may be black anodized per MIL-A-8625 in lieu of painting the interior and prior to painting the exterior.

Surfaces to be painted shall be painted with not less than a primer coat and a finish in accordance with Master Painters Institute reference #49, in the specified color. The paint shall be applied to at least 2.5 mils (63.5 microns) thickness and the final painted surfaces shall be free of blotches, scratches, and runs.

As an alternative to painting, powder coating may be used. The baked film shall have a minimum thickness of 2.5 mils (63.5 microns) and there shall be no areas where substrate shows through the coating.

Alternative finishing methods that provide the same level of protection or greater may be used upon approval of the purchasing authority. Leaded paint or paints containing isocyanates or hazardous substances shall not be used.

3.9 Environmental Requirements. The equipment is to be designed for outdoor installation with continuous operation under the environmental conditions specified below.

3.9.1 Temperature. The temperature range shall be from -40°F (-40°C) to +149°F (+65°C). The clinometer (par 3.3.3.1) shall meet all the performance requirements of 3.3.3.1 when operated over this temperature range.

3.9.2 Altitude. The pressure altitude shall range from -300 feet (-91.44 meters) to 10,000 feet (3,048 meters).

3.9.3 Temperature Shock (Thermal Shock). The LHA external surfaces (including projection lenses) shall be exposed to a sudden application of cold water at a temperature of +32°F to +41°F (0° to +5°C) when the LHAs reach stable operating temperature.

3.9.4 Humidity. Relative humidity shall be up to 100 percent, including conditions where condensation takes place in the form of both water and frost.

3.9.5 Sand and Dust. The system shall tolerate windblown dust particles of 20±5µm mean diameter blowing at 1750 ft/min (8.9m/s) and sand particles of 150 to 850 µm blowing at 3540 ft/min (18 m/s)

3.9.6 Rain. The system shall be capable of withstanding windblown rain at a rate of 6 in/hr (1.6 mm/min) at wind speeds of 40 mph (18 m/sec).

9/30/2008

FAA-E-3007

3.9.7 Salt Spray. The system shall be capable of withstanding salt-laden atmosphere with relative humidity as stated in 3.9.4. The salt spray shall have a concentration of 5 percent sodium chloride, by weight.

3.9.8 Solar Radiation (Sunshine). The system shall be capable of withstanding sunshine intensity of 1120 W/M² (355 BPH³) with spectral components as defined in Table 505.4A-1 of MIL-STD-810 with ambient temperatures as stated in 3.9.1 of this document.

3.9.9 Vibration. The LHAs and the PCA shall be capable of withstanding vibrations in the frequency range of 10 to 2,000 Hz. See paragraph 4.5.10(b) for limits.

3.9.10 Ice Accumulation. The LHA shall be designed to prevent the accumulation of ice on the face of the lenses when exposed to an air temperature of 14°F (-10°C) and water droplet temperature of 32°F to 37.4°F (0°C to 3°C).

3.10 Transient Suppression. Transient suppression devices shall be provided for all power lines at their first point of interface with the equipment. The return for the lightning transient protection devices shall be connected to earth ground via a separate dedicated ground lug that will accommodate not less than a No. 6 AWG conductor. Transient protection shall also be included for signal and power lines that interconnect the PCA and the LHAs. The transient protection for signal lines and the LHA power lines shall be in accordance with FAA-STD-019, Lightning and Surge Protection, Grounding, Bonding and Shielding Requirements for Facilities and Electronic equipment.

3.10.1 Transient waveforms. The equipment shall be designed to suppress switching transients and to withstand transient increases superimposed on the 120/240 VAC rms power line input voltage that reach a peak value of 500 V for as long as 50 milliseconds. In addition, the equipment shall be designed to withstand lightning transients superimposed on each input power line. These transients shall be characterized as 8 by 20 microseconds (wave form) current surges of 10,000 A with the subsequent power-follow currents and voltage surges of up to 10 kV/microsecond (minimum). The current surge waveforms are described in ANSI Standard C61.1.

3.10.2 Parameters. Equipment performance and operational functions shall not be degraded beyond the specification requirements by the above transients when each type of transient is superimposed a minimum of five times on each power input terminal while the equipment is energized

3.11 Electromagnetic Interference Control.

3.11.1 Conducted Emissions Conducted interference levels on incoming AC power leads, control leads, and signals leads shall be not greater than the limits for CE102 as defined in MIL-STD-461 using a frequency range of 10 Khz to 10 MHz.

3.11.2 Radiated Emissions Radiated emission shall be not greater than the limit for RE102 of MIL-STD-461 using a frequency range of 2 MHz to 1 GHz.

9/30/2008

FAA-E-3007

3.11.3 Conducted Susceptibility - Conducted Susceptibility of the system shall be in compliance with CS114 of MIL-STD-461. The frequency range shall be 10 kHz to 200 MHz, and Curve #2 of Figure CS114-1 of MIL-STD-461 shall be used for the limit in accordance with Table III for Navy ground equipment.

3.11.4 Radiated Susceptibility Radiated Susceptibility of the system shall be in compliance with RS103 of MIL-STD-461. The frequency range shall be 2 MHz to 18 GHz. The electric field intensity shall be in accordance with the limits for Navy ground equipment to Table VII RS103 limits for Navy ground equipment of MIL-STD-461.

3.12 Electrical Safety.

3.12.1 Dielectric Strength. For the Dielectric Strength test, the LHAs must be connected to the PCA, and all internal components connected and power switches turned ON. See MIL-STD-202, Method 301 for reference.

3.12.1.1 Power Leads. The PAPI shall be designed to withstand a voltage of 1500 VAC RMS value applied between the AC input of the system and chassis ground without any arc-over. Transient suppression devices and EMI filters that are connected to input power are not required to survive this level and may be disconnected for test purposes. Note that this is a SYSTEM requirement and that power leads that go from the PCA to the LHA must also pass this requirement.

3.12.1.2 Remote Control Input. The Remote Control Input shall be designed to withstand a voltage of 500 VAC RMS value applied between it and the chassis ground without any arc-over. Transient suppression devices and EMI filters that are connected to the Remote Control Input are not required to survive this level and may be disconnected for test purposes.

3.12.2 Ground Bonding Safety ground connections to equipment chassis shall have less than 1 milli-ohm of resistance.

3.13 Assembly, Wiring, and Marking.

3.13.1 Assembly. Assembly of all units shall be in a permanent manner with the components accessible for servicing, replacement, or repairs. Bolts used in assembling units shall be equipped with captive nuts; bolt lengths shall be of chosen so that at least three full threads will show over the nut after tightening. Lock washers of the internal tooth type shall be used on all bolts where good electrical continuity is required for grounding. The chassis shall not be used as a current-carrying part of the electrical circuitry.

3.13.2 Wiring. Connecting wires shall be copper, shall have the proper insulation rating and be of adequate AWG size for the application, as specified in National Electric Code Article 310. Unless otherwise specified, the wires and wiring shall conform to the National Electrical Code for panel-board wiring. Insulated conductors may be closely grouped together, with the bundles secured by flame-retardant lacing or wiring clips and properly trained and supported to avoid strain on the connections. Wire bends with short radii shall be taken in such a way as to avoid nicking or cutting the conductors. Wire that

9/30/2008

FAA-E-3007

interfaces with external signals shall be chosen to also meet the dielectric strength requirements of section 3.12.

3.13.3 Marking. All equipment components shall be clearly identified by nameplates or bold permanent type stencils. Identification markings shall agree with designations on the wiring diagram and parts list. All control wires shall be provided with end identification in the form of a plastic band around the wire with identifying markings permanently stamped thereon, by markings permanently stamped into the wire itself, or other methods upon approval of the purchasing authority. All power conductors shall be similarly marked, except that a permanently stamped rigid laminate tag may be attached near the cable ends in lieu of the above. The terminating points for all wires and cables at terminal blocks, as well as the terminal blocks, shall be clearly identified. The identification shall correspond to the circuit and terminal designations as shown on the interconnection wiring diagram and on applicable diagrams contained in the instruction book.

3.14 Workmanship. Workmanship shall be in accordance with MIL-HDBK-454, Requirement 9.

3.15 Brazing. Brazing shall be in accordance with MIL-HDBK-454, Requirement 59, except that electrical connections shall not be brazed. Paragraph 3.3 of Requirement 59 is not applicable.

3.16 Soldering. Soldering shall be in accordance with MIL-HDBK-454, Requirement 5.

3.17 Maintainability.

3.17.1 Maintainability Design Criteria. The following maintenance parameters must be met by the system:

- (a) Mean Time To Repair (MTTR) - The PAPI shall have a MTTR of not more than 30 minutes and 99 percent of all repair times shall be less than 2 hours. The contractor will demonstrate conformance of this requirement by performing maintainability analysis by using MIL-HDBK-472 as guidance.
- (b) Mean Periodic Maintenance Time (MPMT) - The PAPI MPMT shall be not greater than 2 hours per 3 months, including routine inspection.

3.18 Reliability Design Criteria.

3.18.1 System Reliability Parameters. Mean Time Between Failures (MTBF) of the system shall be not less than 7,000 hours. A system failure occurs when any component in the system prevents the system from meeting any requirement detailed in this specification.

3.19 Expected Life of Product.

The PAPI shall be designed for an expected life-span of twenty (20) years minimum under the environmental conditions specified in section 3.9. This is to be interpreted to mean that the enclosures, mounting components, and major structural parts shall be designed to

9/30/2008

FAA-E-3007

maintain the aiming accuracies specified in section 3.2 for this period. Optical components shall be designed to maintain the light intensity required in section 3.2.2 by the use of periodic cleaning (no removal and reconditioning required). Replacement of LEDs, electrical components, and reconditioning of surface finishes during the product life-span is to be expected.

3.20 Software. If software or firmware is developed for the PAPI, it shall conform to FAA-STD-026.

9/30/2008

FAA-E-3007

4 VERIFICATION

4.1 VRTM. Appendix A contains the Verification of Requirements Traceability Matrix (VRTM) for the PAPI. Methods utilized to accomplish verification include:

- a. Analysis. An element of verification that utilizes established technical or mathematical models or simulations, algorithms, charts, graphs, circuit diagrams, or other scientific principles and procedures to provide evidence that stated requirements were met.
- b. Demonstration. An element of verification that generally denotes the actual operation, adjustment, or re-configuration of items to provide evidence that the designed functions were accomplished under specific scenarios. The items may be instrumented and quantitative limits of performance monitored.
- c. Inspection. An element of verification consisting of investigation, without the use of special laboratory appliances or procedures, of items to determine conformance to those specified requirements that can be determined by such investigations. Inspection is generally nondestructive and typically includes the use of sight, hearing, smell, touch, and taste; simple physical manipulation; mechanical and electrical gauging and measurement; and other forms of investigation.
- d. Test. An element of verification that generally denotes the determination, by technical means, of the properties or elements of items, including functional operation, and involves the application of established scientific principles and procedures.

4.2 Test Articles. When a new design is produced, first article units will be produced as defined in the Statement of Work (SOW) for the contract. The number of first articles that will be required will be determined in that document. These units will be used for performing the Design Qualification Test (DQT) of the product. Where the complement of a system and the prescribed manner of testing require the initial production of a group of identical units; for example, four LHA, and a PCA, then all members of that group will be referred to hereinafter as part of the first article. The units that are produced for field installation will be referred to here as "Production Units".

4.3 PAPI Requirements Testing Discussion. The relationship amongst section 3 requirements, Tables III, IV, and V, and Appendix A, is as follows:

- (a) Section 3 of this specification lists the functional and performance requirements that the equipment must comply with.
- (b) Table III (of Section 4.4.1) specifies the applicability of procedures defined in section 4.5 to the Design Qualification Test for the PCA, LHA, and Clinometer assemblies. Table IV (of Section 4.4.2) specifies the applicability of procedures defined in section 4.5 to the Production Acceptance Test for the production unit PCA, LHA, and Clinometer assemblies. Table V (of Section 4.4.3) specifies the applicability of procedures defined in section 4.5 to the Type Tests for the PCA, LHA, and Clinometer assemblies.
- (c) The Verification of Requirements Traceability Matrix (VRTM) in Appendix A stipulates the method of verification (test, analysis, inspection, demonstration) for

9/30/2008

FAA-E-3007

each “shall” requirement in section 3 of the specification and identifies which test in section 4.5 verifies that requirement.

4.4 Test Methods. Testing of the equipment shall be performed as follows.

4.4.1 Design Qualification Test (DQT).

4.4.1.1 Precondition. The Visual Inspection (4.5.1) and Electrical Safety Tests (4.5.11) must be performed prior to any other DQT tests that require powering up the system.

4.4.1.2 Applicability. The first article units of the LHA shall contain the specified production LEDs while undergoing testing. Any deformation, discoloration, deterioration, malfunction, or operation of the equipment outside of the prescribed conditions or limits of section 3 during or after the conduct of each test shall be cause for rejection.

Required Tests. The following tests shown in Table III, as defined in section 4.5 are required for Design Qualification Testing. In addition, the first article shall undergo tests described in 4.5.19 and 4.5.17 at the conclusion of each test for which it is indicated in Table III.

9/30/2008

FAA-E-3007

Table III. Design Qualification Tests
 “X” = Required, “-“ = Not required

Test	Power and Control Assembly	Lamp Housing Assembly	Clinometer (If separate assembly)	Performance Test Required? (4.5.17 and 4.5.19)
Visual Inspection (4.5.1)	X	X	X	No
Input Power (4.5.25)	X	X		No
Altitude (4.5.2)	X	X	-	Yes
Temperature (4.5.3)	X	X	X	Yes
Sand and Dust (4.5.4)	X	X	-	Yes
Salt Spray (4.5.5)	X	X	-	Yes
Rain (4.5.6)	X	X	-	Yes
Humidity (4.5.7)	X	X	X	Yes
Thermal Shock (4.5.8)	-	X	-	Yes
Solar Radiation (4.5.9)	X	X	-	Yes
Vibration (4.5.10)	X	X	-	Yes
Electrical Safety (4.5.11)	X	X	-	Yes
Transient Suppression (4.5.12)	X	X	-	Yes
Electromagnetic Interference (4.5.13)	X	X	-	No
Lampout Operation (4.5.14)	X	X	-	No
Lamp Housing Aiming (4.5.15)	X	X	-	No
Photometric, first article (4.5.16)	X	X	-	No
Photometric, Production Unit (4.5.17)	X	X	-	n/a
Power and Control Assembly Performance (4.5.19)	X	X	-	n/a
Tilt Detection System Performance (4.5.22)	X	X		No
1000-hour (4.5.20)	X	X	-	Yes
Ice Accumulation (4.5.23)	X	X	-	No
Rigidity Test (4.5.26)	X	-	-	No

4.4.2 Production Acceptance Tests.

9/30/2008

FAA-E-3007

4.4.2.1 Applicability. The Production Acceptance Tests will be performed on all units. First article units will be subjected to the production acceptance test prior to performing DQT. All production units shall pass the production acceptance test prior to delivery.

4.4.2.2 Required Tests. The following tests shown in Table IV, as defined in section 4.5 are required for all production units. In addition to these tests, all other functions of the unit (such as tilt monitors) shall be tested at some point of production, either in the Production Acceptance Test, or during board manufacture to ensure that all production units are fully functional when delivered.

Table IV. Production Acceptance Tests
“X” = Required, “-“ = Not required

Test	Power and Control Assembly	Lamp Housing Assembly	Clinometer (If separate assembly)
Visual Inspection (4.5.1)	X	X	X
2-hour (4.5.21)	X	X	-
Electrical Safety (4.5.11)	X	X	
Lampout Operation (4.5.14)	X	X	-
Photometric, production unit (4.5.17)	X	X	-
LHA Tilt Detection Test (4.5.24)	X	X	

4.4.3 Type Tests.

4.4.3.1 Applicability. Tests shall be performed on regular production equipment or systems in accordance with the requirements in FAA-G-2100.

4.4.3.2 Tests Required. The following tests shown in Table V, as defined in section 4.5, are required for all Type Test Sample units.

Table V. Type Tests
“X” = Required, “-“ = Not required

Test	Power and Control Assembly	Lamp Housing Assembly	Clinometer (If separate assembly)
Temperature (4.5.3)	X	X	X
Humidity (4.5.7)	X	X	X
Vibration (4.5.10)	X	X	-

4.5 Test Procedures. The PAPI shall be continuously energized and connected as shown in Figure 6 for all tests except the following: 4.5.4, 4.5.5, 4.5.6, 4.5.11, and 4.5.24. The PAPI shall be tested in accordance with the tests specified herein and the failure criteria of paragraph 5.14 of MIL-STD-810. Failure of a component during test, that requires

9/30/2008

FAA-E-3007

replacement to restore the unit to “as-built” condition, constitutes a failure. During the conduct of the tests specified in 4.5.2 through 4.5.11, a PCA sub-assembly and one LHA sub-assembly may be used.

4.5.1 Visual Inspection. The equipment shall be visually inspected for workmanship, fabrication, finishing, painting, and adequacy of selected parts.

4.5.2 Altitude Test. The altitude test shall be in accordance with Procedure II, Method 500.4, of MIL-STD-810. The equipment shall be tested at atmospheric pressures corresponding to -300 feet (-91.44 meters) and 10,000 feet (3,048 meters) altitude at both -40°F (-40°C) and +120°F (+49°C). This test may be combined with the temperature test of section 4.5.3 (see the description in that section).

4.5.3 Temperature Test. The high temperature test shall be in accordance with Procedure II, Method 501.4 of MIL-STD-810, except that the temperature shall be +149°F (+65°C). The low temperature test shall be in accordance with procedure II, Method 502.4, of MIL-STD-810, except that the temperature shall be -40°F (-40°C). The 2-hour operational test (4.5.21) will start 2 hours after temperature stabilization. Procedure II shall be performed for three cycles during the low temperature test. The operating parameters of the equipment (light levels, monitors, etc.) shall be adjusted at the beginning of this test; the high and low temperature tests shall then be completed without any further adjustment. The altitude test may be combined with this test by operating the equipment at atmospheric pressures corresponding to -300 (-91.44 meters) and then again at 10,000 feet (3,048 meters) altitude at both the high and low temperatures. The clinometer's performance requirements of 3.4.1 shall be verified over its entire operating range using the test methods described above.

4.5.4 Sand and Dust Test. The sand and dust test shall be in accordance with Procedure I and Procedure II, Method 510.4, of MIL-STD-810. Rotate the equipment 120° twice with the initial orientation being with the stream aimed directly at the lenses. For blowing dust, a 140 mesh silica flour or equivalent media shall be used with a wind speed of 1750 ft/min (8.9 m/s). For blowing sand, a particle size of 150µm to 850µm with a mean of 90±5 percent by weight smaller than 600µm and larger than 149µm and at least 5 percent by weight 600µm and larger shall be used with a wind speed of 3540 ft/min (18 m/s).

4.5.5 Salt Fog Test. The salt fog test shall be in accordance with Procedure I, Method 509.4, of MIL-STD-810 for not less than 168 hours. The salt spray shall have a concentration of 5 percent sodium chloride, by weight. Salt buildup as a result of the test may be removed with tap water.

4.5.6 Rain Test. The rain test shall be in accordance with Procedure I, Method 506.4, of MIL-STD-810. Wind speed shall be 40 mph (18 m/sec) with a rain rate of 6 in/hr (1.6 mm/min) using drop sizes of 0.02in to 0.18in (0.5 mm to 4.5 mm). The exposure shall be on each of the four sides for 30 minutes each with the initial orientation being with the wind aimed directly at the lenses. The equipment shall be turned on and brought to stable operating temperature for each exposure before starting rainfall and operated during the exposure. Water temperature shall be room ambient; 77°F±18°F (25°C±10°C).

4.5.7 Humidity Test. The humidity test shall be in accordance with Method 507.4, of MIL-STD-810, except that a total of three complete cycles (72 hours) will be required and

9/30/2008

FAA-E-3007

the maximum temperature shall be +120°F (+49°C). The base of the clinometer shall be rustproof such that the clinometer can meet all the performance requirements of 3.4.1 when subjected to the humidity test described above.

4.5.8 Thermal Shock Test. The equipment shall be installed as in normal use and operated at maximum intensity until the temperatures have stabilized. At least 3 gallons (11.35 liters) of water at a temperature of 32° to +41°F (0° to +5°C) shall be sprayed on the top surface of the LHA and directly on the lenses or window. There shall be no cracking of glass or metal.

4.5.9 Solar Radiation (Sunshine) Test. The test shall be conducted in accordance with Procedure II, Method 505.4, of MIL-STD-810 for 56 cycles (24 hours each). The equipment shall be operated for 1 hour during the third cycle when the test item has reached its peak temperature.

4.5.10 Vibration Test. The equipment shall be tested as described below.

(a) Vibration planes. The test assembly shall be vibrated in three planes or directions as follows:

In a direction perpendicular to the test table (vertically).

Horizontally, parallel to the light beam axis.

Horizontally, at right angles to the light beam axis.

(b) Frequencies. The test assembly shall be vibrated through a frequency range of 10 to 2,000 cycles per second (cps) in each plane until the acceleration shown in Table VI are reached. Duration of each sweep shall be 10 minutes. A sweep shall be defined as the vibration of the test assembly through a frequency range as shown in Table VI.

Table VI. Vibration Test Data

Acceleration in G's	Frequency (CPS)
0.020 inch (.5mm) double amplitude (Peak to Peak displacement)	10-70
3	70-200
3	200-500
3	500-2,000

Following the vibration test, the equipment shall be thoroughly examined for mechanical failure of any component, loosening of any part, cracked or broken seals, continuity of electrical circuits, and possible damage to supports, etc.

9/30/2008

FAA-E-3007

4.5.11 Electrical Safety.

4.5.11.1 Dielectric Test. A dielectric test shall be performed on power and Remote Control leads of the production models in accordance with MIL-STD-202. The test shall be performed using 60Hz ac voltage applied for 1 minute between insulated leads and the chassis. The LHAs are to be connected to the PCA and all internal components are to be connected during the test. All power switches must be set to the ON position and all applicable wires connected together (all power, or all remote control input).

All power wiring	1.5 kilovolts (kV) RMS
Remote Control Input, and wiring	0.5 kilovolt (kV) RMS

4.5.11.2 Ground Bonding Test.- A ground bonding test shall be performed on the PCA and LHA production models by passing a current of 25 Amps or more through the chassis to a wire connected to the safety ground terminal. The measured impedance shall be 1 milliohm or less. This test may be performed using a manual or automatic tester.

4.5.12 Transient Suppression Test. A surge generator shall be used to superimpose on the 120/240 VAC input power lines each of the applicable types of transients specified in 3.10 at least five times. Transient surges shall be applied between each input power line and the grounded neutral. The preset transient control levels shall be verified by open-circuit and short-circuit tests prior to applying each test surge to the unit. Test surges shall be superimposed while operating the PCA at high (day) and low (night) light outputs respectively. The photo sensing device shall be used to alternately switch the system between high (day) and low (night) mode before superimposing every other transient test surge. The time interval between successive superimposition of test surges shall be no more than 30 seconds. The equipment shall be continuously energized during the entire transient suppression test, which shall commence with the conduct of a performance test (4.5.19). Transient recovery time shall be tested using a return to full brightness for the selected mode as the measure of the 3-second recovery time requirement. The light output shall be within ± 2 percent of the output measured, in accordance with 4.5.19, at the commencement of the transient suppression test. This test will then be repeated between the LHA power lines and input power neutral, and then between the LHA signal lines and the input power neutral.

4.5.13 Electromagnetic Interference Test. A production model of the power and control assembly shall be tested for conformance to the electromagnetic interference control requirements specified in 3.11. The power and control assembly shall be connected as shown in Figure 6. In addition, the power and control assembly shall be connected to a power source using no less than 300 feet (91.44 meters) of wire of 12AWG or larger. The test shall be performed in both day and night moods. The LEDs shall be installed in each LHA during the conduct of the test. The electromagnetic interference measurement shall be in accordance with the following test methods of MIL-STD-461:

Conducted Emissions	CE102
Radiated Emissions	RE102
Conducted Susceptibility	CS114
Radiated Susceptibility	RS103.

9/30/2008

FAA-E-3007

4.5.14 Lampout Operational Test The LHAs shall be connected to the PCA in their normal configuration and shall be operated at high (day) output at an ambient temperature of $77^{\circ} \pm 18^{\circ}\text{F}$ ($+25^{\circ} \pm 10^{\circ}\text{C}$) to test the lampout circuitry. The method to be used shall be determined by the method used to monitor operation of the LEDs. If direct measurement of the light output is used, a method shall be used to decrease the amount of light to the sensor to trigger its operation. If the LEDs are monitored by measuring their characteristics, then test points shall be used to artificially trigger the circuit by simulating a defective condition.

4.5.15 Lamp Housing Assembly Aiming Test. The LHA shall be aimed to a setting of $0.00^{\circ} \pm 1$ minute. The light pattern shall be projected onto a surface located 100 ± 1 feet (30.48 ± 0.3 meters) in front of the LHA and the centerline of the red/white transition shall be verified to be coincident with the LHA optical centerline. Following this, the LHA shall be aimed to an angle of 2.00° using the calibrated production model clinometer (or internal clinometer), and its angular setting shall be verified to be $2.00^{\circ} \pm 2$ minutes. The procedure shall be repeated in strict sequence for aiming angles of 5.00° , 3.00° , 6.00° , and 2.00° . Aiming angle repeatability at 2.00° shall be within ± 3 minutes of arc. The angular setting is to be verified using equipment external to the production equipment and the method used shall be provided by the manufacturer and approved by the FAA.

4.5.16 First Article Photometric Test. Four LHAs shall be energized at the high (day) output setting, and each LHA shall be tested to verify compliance with the minimum photometric requirements of 3.2. The method used shall be provided by the manufacturer and approved by the FAA.

4.5.17 Production Unit Photometric Test. All production LHAs shall be tested to verify that the red/white transition meets the requirements of 3.2.1. The method used shall be provided by the manufacturer and approved by the FAA.

4.5.18 Clinometer Test. If the PAPI requires a clinometer for setting aiming angles, the accuracy of the clinometer shall be verified at an independent certified laboratory, and results of the test shall be submitted to the FAA for approval.

4.5.19 Power and Control Assembly Performance Test. The power and control assembly shall be connected to a single phase, 60 Hz, 120/240V power source with neutral grounded in accordance with National Electric Code. The PCA shall control a set of four LHAs populated with their normal complement of LEDs. The light output at the high (day) setting shall be adjusted to nominal using the manufacturer's recommended method with a nominal input voltage of 240 V. At the conclusion of the test, the light output shall be within $\pm 2\%$ of the nominal setting. The input voltage shall be externally varied through the range of 216 V to 264 V. The light outputs shall not deviate more than $\pm 2\%$ of the nominal setting when the input power is varied from 216 to 264V. The light output at the low (night) setting shall be adjusted and demonstrated as above and shall be within the $\pm 2\%$ limitation. The photo sensing device shall be electrically connected to the assembly. Operation, within the foot-candle (lux) limits set forth in 3.3.2.4.3 of this specification, shall be demonstrated using a certified light source with color temperature of 6500° Kelvin (K). During the test, the remote control input shall be used to turn the system ON/OFF at least 100 times.

4.5.20 1000-Hour Operational Test The equipment shall be tested without failure for 1000 continuous hours at an ambient temperature of $+77^{\circ} \pm 18^{\circ}\text{F}$ ($+25^{\circ} \pm 10^{\circ}\text{C}$). A light source

9/30/2008

FAA-E-3007

shall be used to illuminate the photo-sensor or not in order to vary the output setting so that the unit is at the low level (night) for 12 hours and at the high level (day) for 12 hours. The elapsed time indicator shall indicate the duration of operation at the high-intensity setting. The performance test described in 4.5.19 shall be conducted within 1 hour following the conclusion of the 1000-hour operational test. Prior to conducting the test, the PAPI control cabinet input and control voltages shall be measured and recorded. In addition, care shall be taken to ensure that the PAPI is fully operational (i.e., all lights are in good working condition).

4.5.21 Two-hour Operational Test. The equipment shall be tested for 2 continuous hours at an ambient temperature of $+77^{\circ} \pm 18^{\circ}\text{F}$ ($+25^{\circ} \pm 10^{\circ}\text{C}$). The power and control assembly shall be connected to a single phase, 60 Hz, 120/240V power source with neutral grounded in accordance with National Electric Code. The test load shall consist of a set of four LHAs populated with their normal compliment of LEDs. The light output at the high (day) setting shall be adjusted to nominal using the manufacturer's recommended method with a nominal input voltage of 240 V. A light source (certified source not needed here) shall be used to illuminate the photo-sensor or not in order to switch the output setting so that the unit is at the low level (night) for 50 percent of each hour and at the high level (day) for 50 percent of each hour. The elapsed time indicator shall indicate the duration of operation at the high-intensity setting. At the conclusion of the test, the light output shall be within $\pm 2\%$ of the nominal setting. The input voltage shall be externally varied through the range of 216 V to 264 V. The light outputs shall not deviate more than $\pm 2\%$ of the nominal setting when the input power is varied from 216 to 264V. Operation at the low (night) setting shall be adjusted and demonstrated as above and shall be within the $\pm 2\%$ limitation. The photo sensing device shall be electrically connected to the assembly. Operation, within the foot-candle limits set forth in 3.3.2.4.3 of this specification, shall be demonstrated using a certified light source with color temperature of 6500° Kelvin (K). At the end of 2 hours, each LHA shall be tilted, one at a time, both forward and backward directions and system shutdown shall occur after 10 seconds. System reset between each LHA tilt is allowed.

4.5.22 Tilt Fault Detection System Performance Test. The PCA and LHAs shall be connected into a normal operating configuration and all the LHA angles set to 3° and the tilt detection method set per the manufacturer's instructions. On LHA #1, lower the aiming angle to $2^{\circ} 50'$ and verify that the system is still operating. Lower the angle to $2^{\circ} 25'$. The system should continue to operate for at least 10 seconds and then shut down with a tilt indication for LHA #1 in the PCA. Raise the aiming angle to $3^{\circ} 25'$ and reset the system. The system should remain operating. Raise the aiming angle to $4^{\circ} 5'$. The system should continue to operate for at least 10 seconds and then shut down with a tilt indication for LHA #1 in the PCA. Lower the aiming angle back to 3° and reset the system. Verify that the system continues to operate. Repeat this same action for LHAs #2, #3, and #4.

4.5.23 Ice Accumulation Performance Test. An LHA shall be set up in the appropriate chamber and tested according to MIL-STD- 810, method 521.2, procedure 1. The chamber temperature shall be -14°F (-10°C) and the water droplet temperature shall be 32°F to 37°F (0°C to 3°C). The LHA shall be energized and LEDs turned on and the chamber allowed to stabilize for $\frac{1}{2}$ hour before the water droplets are dispersed. Testing shall continue for $\frac{1}{2}$ hour, during which no ice shall accumulate on the face of the LHA. The water droplets shall be dispensed in such a way that they impinge directly on the face of the LHA, not on the

9/30/2008

FAA-E-3007

overhang. The test shall also be performed on the PCA in the same way to determine if ice builds up on the photosensor.

4.5.24 LHA Tilt Detection Test. This test verifies the tilt detection in individual LHAs. The LHA shall be connected to a test fixture of the manufacturer's design and the LHA angle set to 3° and the tilt detection method set per the manufacturer's instructions. Lower the aiming angle to 2° 50' and verify that a tilt indication does not occur. Lower the angle to 2° 25' and verify that a tilt indication occurs (if the delay is built into the LHA, then verify that the delay is correct). Return the LHA to a 3° aiming angle and verify that the tilt indication goes away. Raise the aiming angle to 4° 5' and reset the system and verify that a tilt indication occurs. If the delay is built into the LHA, then verify that the delay is correct.

4.5.25 Input Power Test. This test verifies that the input power is within the limits of 3.3.2.2 and that the Total Harmonic Distortion is within the limits of 3.3.2.2. Measurements shall be performed with the LHAs in Day mode and with any heaters that are used energized.

4.5.26 Rigidity Test. This test verifies that the LHA is rigid enough to maintain the photometric requirements of 3.3.2. Perform the rigidity test described in FAA advisory circular 150/5345_28F section 4.11.

4.6 Test Performance. All tests described above shall be performed at the contractor's expense. The following tests may be performed at the contractor's facility or an independent testing laboratory: 4.5.1, 4.5.11, 4.5.14, 4.5.15, 4.5.17, 4.5.18, 4.5.19, 4.5.20, 4.5.21, 4.5.22, 4.5.24. The following tests shall be performed at an independent testing laboratory: 4.5.2, 4.5.3, 4.5.4, 4.5.5, 4.5.6, 4.5.7, 4.5.8, 4.5.9, 4.5.10, 4.5.12, 4.5.13, 4.5.16, 4.5.23, 4.5.26. All tests may be witnessed by an FAA representative.

9/30/2008

FAA-E-3007

5. PACKAGING.

Packaging requirements shall be as specified in the contract or order (see paragraph 6.2 of MIL-STD-961).

6. NOTES. The contents of the subparagraphs below are only for the information only. They are not contract requirements, and are not binding on either the Government or the contractor except to the extent that they may be specified elsewhere in the contract as such. Any reliance placed by the contractor on the information is wholly at the contractor's own risk.

6.1 Cross-reference with NAS-SS-1000. Appendix B contains traceability with NAS-SS-1000 Requirements for PAPI equipment.

6.2 Mounting hardware not furnished under this contract. The aluminum flanges shall be designed for installation on a concrete pad and shall have a threaded boss to receive the frangible coupling. The adjusting hardware shall be designed to prevent any displacement of the optical system due to vibration. Frangible couplings, emt, and aluminum flanges are not furnished under this specification.

6.3 Flashing PAPI. At a future point in time, it may be required to create a "Flashing PAPI", which can be caused to flash ON and OFF on command. If this requirement becomes mandatory, it will be added to the Statement of Work. Providing a blanking input that is available to an add-on flashing control card, as well as space for an add-on flashing control card, will be required if this is the case.

6/16/2009

FAA-E-3007 W/ Change 1

APPENDIX A. Verification of Requirements Traceability Matrix (VRTM)

I= Inspection, D= Demonstration, A= Analysis, T= Test

#	SEC#	HEADING	DESCRIPTION	DOT	OT&E	SEC. IV	Typ e Test
1	3.1	General functional requirements	The PAPI shall meet the requirements specified herein, and shall consist of: (a) Four LHA, with integral mounting and adjustment hardware. (b) One Power and control assembly. (c) One aiming instrument set (this is not required for systems with built-in electronic clinometers).	I	I		
	3.2	Photometric Requirements					
2	3.2.1	Light Beam	Each PAPI LHA shall provide a split beam of light consisting of white light in the top sector and red light in the bottom sector as viewed from the front.	I	I		
3	3.2.1	Light Beam	The transition from red light to white light shall occur within an angle of 3 minutes of arc at the beam center and within an angle of 5 minutes of arc at the beam edges.	T	T	4.5.17	T
4	3.2.1	Light Beam	The transition band shall be flat to within 3 minutes of arc.	T	T	4.5.17	T
5	3.2.1	Light Beam	The PAPI shall provide usable visual approach guidance out to ± 10 degrees either side of the extended runway centerline.	T	T	4.5.17	T
6	3.2.2	Light Intensity	The PAPI shall provide guidance at two light intensity steps.	D	I		
7	3.2.2	Light Intensity	Day mode operation shall be defined as the minimum values shown in Figure 3	T	I	4.5.16	
8	3.2.2	Light Intensity	Night mode operation shall be defined as 10 percent of the values shown in Figure 3.	T	I	4.5.16	
9	3.2.3	Light Colors	The white light shall be generated by LEDs having a color temperature of 4500K to 10,000K.	I			
10	3.2.3	Light Colors	The red light shall be generated by LEDs having a spectral output between 620.5nm and 645nm.	I			
11	3.2.4	Light Beam Aiming Tolerance	The centerline of the transition zone (i.e. the vertical area of change from red light to white light) of each LHA projected light signal shall be parallel to the zero aiming angle projection within ± 5 minutes of arc.	T	T	4.5.15	
	3.3	Sub-assemblies					
	3.3.1	General					
12	3.3.1.1	General	The LHA shall use LEDs as the light producing elements.	I			
13	3.3.1.1	General	The LHA shall consist of: A & B & C & D & E	I	I		
14	3.3.1.2.1	Operational Requirements	The LHA shall be designed to maintain the required light beam orientation and photometric requirements in accordance with section 3.2 performing under the environmental conditions specified in 3.9.	A			
15	3.3.1.2.2	Operational Requirements	Upon receiving the appropriate command from the PCA, the LHA shall operate in either night mode or day mode.	D			
16	3.3.1.2.2	Operational Requirements	The default mode for an LHA absent of any LHA command, shall be non-illuminated.	D			

6/16/2009

FAA-E-3007 W/ Change 1

17	3.3.1.2.2	Operational Requirements	The LHA shall report status information back to the PCA.	D			
18	3.3.1.2.2	Operational Requirements	As a minimum this information shall include: the mode that it is in (Day/Night); whether the light output is low or in tolerance for the selected mode; and whether a tilt fault condition exists (or angle information from a solid-state clinometer for interpretation by the PCA).	D			
19	3.3.1.2.2	Operational Requirements	The control and status signals shall be implemented by discrete signals, a serial wire link, or a fiber-optic link.	I			
20	3.3.1.2.3	Operational Requirements	In accordance with MIL-STD-1472F section 5.9.11.3, the weight of the LHA, excluding mounting legs, shall not be greater than 100 pounds (45 kilograms (kg)).	I			
21	3.3.1.2.4	Operational Requirements	The LHA shall be considered to be unserviceable if greater than 25 percent of either the red or white LEDs have failed.	T		4.5.14	
22	3.3.1.2.4	Operational Requirements	The LHA shall also be considered to be unserviceable if the light output is less than the values stated in 3.2.2. for the selected mode (day or night).	T		4.5.14	
23	3.3.1.2.4	Operational Requirements	If either of these two conditions is present, a signal shall be generated and sent to the PCA reporting the condition such that the PCA can turn off the LEDs.	T		4.5.14	
24	3.3.1.3.1.1	Optical bench	The optical bench or benches shall be constructed of corrosion resistant metal and shall, in conjunction with the structural design, provide rigidity to maintain the required optical alignment when subjected to a load of 15 lbs per square foot (73 kilograms per square meter).	T		4.5.26	
25	3.3.1.3.1.2	Optical bench	The maximum dimension of any drain hole (if required) shall be not greater than 1/16 inch (1.57 millimeters (mm)) in diameter to prevent intrusion of insects.	I			
26	3.3.1.3.1.3	Optical bench	If an internal clinometer is not used, then a transverse leveling pad and aiming pad compatible with the clinometer specified in Section 3.3.3 shall be an integral part of the LHA and accessible on the outside of the LHA without opening any LHA covers or the housing shell.	I	I		
27	3.3.1.3.1.3	Optical bench	The tolerance for the flatness of the calibration bar shall be ≤ 0.005 inches.	I	I		
28	3.3.1.3.1.4	Optical bench	If an internal clinometer is used, a means must be provided to read it without opening any LHA covers or the housing shell.	I	I		
29	3.3.1.3..2.1	Housing shell	The optical bench shall be enclosed by a housing shell made of inherently corrosion resistant metal.	I			
30	3.3.1.3..2.1	Housing shell	Removal or pivoting of the housing shell shall permit easy access to the internal components mounted on the optical bench.	D			
31	3.3.1.3..2.1	Housing shell	The housing shell shall be installed on a mounting base (see figure 4) by means of threaded fasteners.	I			
32	3.3.1.3..2.1	Housing shell	The housing shell shall overlap the sides of the unit and be fastened in such a manner that rain will not enter the unit if the gaskets fail or if fasteners are lost.	I	I		
33	3.3.1.3..2.1	Housing shell	The housing shell shall include an integral deflection plate on the top front edge to prevent the pilot from seeing light reflected off the back of the LHAs.	I	I		
34	3.3.1.3..2.1	Housing shell	The integral deflection plate shall have a minimum height of 7 percent of the length of the housing shell (adequate protection up to 4 degrees above flight path).	I	I		

6/16/2009

FAA-E-3007 W/ Change 1

35	3.3.1.3.2.2	Housing shell	All points that have electrical potentials in excess of 70 VDC or 50 VAC shall be shielded by guards or barriers to prevent accidental contact by a service technician.	I	I		
36	3.3.1.3.2.2	Housing shell	The the LHA shall be provided with an interlock to disable power when the housing shell is opened.	I	I		
37	3.3.1.3.2.2	Housing Shell	Interlocks shall include a mechanical override.	I	I		
38	3.3.1.3.2.2	Housing Shell	In addition, closure of the housing shall either reset the override or shall be prohibited if the override is active.	I	I		
39	3.3.1.3.3.1	Power input cable and Signal Cable entrance connector	Space shall be reserved in the rear of LHA to permit connection of the incoming power cable to the terminal block.	I	I		
40	3.3.1.3.3.1	Power input cable and Signal Cable entrance connector	The power cable shall enter through one hole located in the bottom rear of the housing.	I	I		
41	3.3.1.3.3.1	Power input cable and Signal Cable entrance connector	The control and status signals cable (or fiber) shall enter through another hole located in the bottom rear of the housing.	I	I		
42	3.3.1.3.3.1	Power input cable and Signal Cable entrance connector	The earth ground wire shall be brought in through a separate hole from the power or signal wires.	I	I		
43	3.3.1.3.3.1	Power input cable and Signal Cable entrance connector	The holes shall be sized to allow the installation of strain relief connectors for liquid tight flexible conduit of 1 inch (30.2mm).	I	I		
44	3.3.1.3.3.2	Power input cable and Signal Cable entrance connector	A separate ground lug shall be provided for earth ground.	I	I		
45	3.3.1.3.3.2	Power input cable and Signal entrance connector	The ground lug shall have a slotted, green-colored head suitable for a No. 6 American Wire Gauge bare copper ground wire	I	I		
46	3.3.1.3.3.2	Power input cable and Signal entrance connector	A hole of up to ½ inch (12.7 mm) diameter shall be provided in the bottom of the LHA near the wire entrance holes.	I	I		
47	3.3.1.3.4.1	Mounting Provisions	The LHA shall be designed for installation on a concrete foundation using the footprint shown in Figure 5.	I	I		
48	3.3.1.3.4.1	Mounting Provisions	The mounting base shall have three adjustable legs to permit aiming of the light beam to any vertical angle from 1.5 degrees up to 6degrees.	D	I		
49	3.3.1.3.4.1	Mounting Provisions	Also, the mounting and adjustment hardware shall permit transverse leveling where any mounting leg may be up to 1 inch (2.54 cm) higher or lower than any other leg after installation	D			
50	3.3.1.3.4.3	Mounting Provisions	The attachments to the mounting base shall be designed in such a way that aiming may be accomplished without opening the LHA in any way.	D			
51	3.3.1.3.4.3	Mounting Provisions	The leg attachments to the mounting base shall not create any stress on the mounting base at any angle from 0 to 6 degrees.	D			
52	3.3.1.3.4.3	Mounting Provisions	In addition, the leg attachments shall be designed to bend or fold over without damaging the mounting base if the	D			

6/16/2009

FAA-E-3007 W/ Change 1

			unit is forcibly dislodged from the frangible couplings.				
53	3.3.1.4.1.1	LEDs	LEDs shall be used to produce the white and red portions of the beam without a filter element.	I			
54	3.3.1.4.1.1	LEDs	The LEDs shall have a rated life of 50,000 hours or more when operated at day mode intensity.	A			
55	3.3.1.4.1.1	LEDs	The LED drivers shall have enough range to produce the light levels required in 3.2.2 over the entire lifespan of the LEDs.	A			
56	3.3.1.4.1.1	LEDs	A means shall be provided to automatically adjust the light intensity over the lifespan of the system to maintain the minimum required light levels of 3.2.2.	A			
57	3.3.1.4.1.2	LEDs	The LHA shall use LED modules or individual LEDs that can be easily replaced at the field level to restore the LHA to normal operation.	I			
58	3.3.1.4.1.2	LEDs	If an array is used, the LEDs must be connected such that a single LED failure will not produce an axial.	D			
59	3.3.1.4.1.3	LEDs	The LED mounting shall permit firm and positive positioning of the LEDs.	D			
60	3.3.1.4.1.3	LEDs	The mounting shall be designed to facilitate removal and replacement to meet the required Mean Time To Repair (MTTR) stated in Section 3.18.1(a).	A			
61	3.3.1.4.1.3	LEDs	Replacing LEDs or LED modules shall not require optical realignment.	D			
62	3.3.1.4.1.4	LEDs	The method of controlling the intensity shall not decrease the life expectancy of the LEDs.	A			
63	3.3.1.4.1.4	LEDs	Any method used to modulate the intensity of the LEDs shall not produce any visible "strobe effects" (ie. Modulated at a rate <120Hz) when viewed at a distance greater than 100±1 feet (303.± 0.3 meters).	D			
64	3.3.1.4.2	Projection Lens	The glass projection lenses shall be mounted in a vertical frame or frames made of inherently corrosion resistant metal which may be an integral part of the optical bench.	I			
65	3.3.1.4.2	Projection Lens	Light, including direct sunlight, entering the LHA through the lenses shall not cause any damage to the LHA.	I			
66	3.3.1.4.2	Projection Lens	The lenses shall be recessed under an overhang to minimize the direct impingement or splash-back of rain or snow on the lenses...	I	I		
67	3.3.1.4.2	Projection Lens	And the overhang shall protrude beyond the front of the unit by a distance equal to or greater than the height of the housing shell.	I	I		
68	3.3.1.4.3.1	Terminal block	Terminal blocks shall be provided in the rear of the LHA for all electrical interfaces to the LHA;	I	I		
69	3.3.1.4.3.1	Terminal block	Power connections and control and status signals shall be on different terminal blocks that are clearly labeled for each purpose.	I	I		
70	3.3.1.4.3.2	Terminal block	Either enclosed base type or DIN rail type terminal blocks shall be used.	I	I		
71	3.3.1.4.3.2	Terminal block	Terminal blocks shall provide inherently corrosion resistant terminals rated to carry 150% of expected current at 250 VAC.	I			
72	3.3.1.4.3.2	Terminal block	In addition, the terminal blocks shall satisfy the dielectric strength requirements of 3.12.	I			
73	3.3.1.4.3.3	Terminal block	Electrical contact surfaces of terminals shall be brass, bronze or copper which satisfies UL 1059 Standard .	I			
74	3.3.1.4.3.3	Terminal block	Pressure screws shall be brass, bronze or stainless steel that satisfy UL 1059 standard .	I			

6/16/2009

FAA-E-3007 W/ Change 1

75	3.3.1.4.3.3	Terminal block	Each pressure- type terminal shall be equipped with a pressure plate to prevent the tip of the screw from turning directly on the wire.	I			
76	3.3.1.4.3.3	Terminal block	The separators shall prevent current leakage under the environmental conditions specified in 3.9.	I			
77	3.3.1.4.3.4	Terminal block	The terminal blocks shall accommodate all internal connections and external cable connections using a dedicated terminal for each conductor	I	I		
78	3.3.1.4.3.4	Terminal block	Marking shall be provided in accordance with 3.13.3.	I	I		
79	3.3.1.4.4.1	Tilt Switch	Each LHA unit shall have a tilt detection system that may consist of either a tilt switch or a built-in solid-state clinometer to determine if the LHA has deviated from its set aiming angle.	I		4.5.22	
80	3.3.1.4.4.1	Tilt Switch	If a tilt switch is used, it shall be of a non-mechanical design that will meet the vibration requirements in accordance with section 4.5.10.	T		4.5.10	
81	3.3.1.4.4.1	Tilt Switch	If a solid-state clinometer is used, there shall be a display internal to the LHA to display the aiming angle and transverse level.	I			
82	3.3.1.4.4.1	Tilt Switch	In addition, if a solid state clinometer is used to measure and display aiming and transverse angle, a means shall be provided to calibrate the device at the depot level.	I			
83	3.3.1.4.4.2	Tilt Switch	The tilt fault detection system shall de-energize the LEDs when the optical pattern is lowered between 1/4 and 1/2 degree or raised between 1/2 and 1 degree with respect to the preset aiming angle.	T		4.5.22	
84	3.3.1.4.4.2	Tilt Switch	The tilt fault detection system shall have a time delay of at least 10 seconds that will prevent intermittent tilt switch indication due to vibration.	T		4.5.22	
85	3.3.1.4.4.2	Tilt Switch	The tilt fault detection system shall have fail-safe operation so that any malfunction of the tilt switch or solid-state clinometer, including loss of input power, shall de-energize the LEDs in all LHAs.	T		4.5.19	
86	3.3.1.4.5	Power supply	Power supplies for the LEDs shall drive the LEDs at the levels specified in 3.2.2	T			
87	3.3.1.4.5	Power supply	The power supply and all associated wiring shall be designed to withstand the dielectric requirement in accordance with 3.12.	T		4.5.11	
88	3.3.1.5.1	Housing shell finish	All exterior and interior surfaces of the lamp housing shell shall be finished in accordance with 3.8.1, using the colors specified in this section.	I			
89	3.3.1.5.2	Interior finish	The deflection plate front surface and all interior surfaces of the housing shell, including the interior surface of the overhang, shall be painted Black, color No. 37038 of FED-STD-595.	I	I		
90	3.3.1.5.3	Exterior finish	All exterior surfaces of the housing shell including the back surface of the deflection plate, shall be painted International Orange, Color No. 12197 of FED-STD-595.	I	I		
91	3.3.1.5.4	Optical bench finish	The optical bench including the projector mounting frames shall be painted in accordance with 3.8.1, with Black, color No. 37038 of FED-STD-595, or as an alternative, black anodized per MIL-A-8625 in lieu of painting.	I			
92	3.3.1.5.5	Mounting base	The LHA mounting base shall be painted in accordance	I	I		

6/16/2009

FAA-E-3007 W/ Change 1

		finish	with 3.8.1, with black, color No. 37038 of FED-STD-595, or alternatively, black anodized per MIL-A-8625 in lieu of painting.				
	3.3.2	Power and control assembly					
93	3.3.2.1	General	The PCA shall control the power to the LHAs	D			
94	3.3.2.1	General	The PCA shall issue commands to the LHAs to go to night mode, or day mode.	T		4.5.22	
95	3.3.2.1	General	The PCA shall receive status back from the LHAs, as a minimum: the mode that it is in; "light output low" for the selected mode; and tilt angle information or tilt fault status.	D			
96	3.3.2.1	General	The control and status signals may be implemented by discrete signals, a serial wire link, or a fiber-optic link.	D			
97	3.3.2.1	General	The PCA shall form one unit that is intended to be installed adjacent to the LHA furthest from the runway.	I			
98	3.3.2.1	General	The weight of the PCA shall be not more than 50 pounds (22.67 kg).	D			
99	3.3.2.1	General	No external cooling shall be required.	I	I		
	3.3.2.2	Operational Requirements.					
100	3.3.2.2.1	Purpose	The PCA shall supply power for operation of the PAPI.	I			
101	3.3.2.2.1	Purpose	When the system is powered up, the PCA shall command the LHAs to illuminate at night intensity, and then if sufficient light is present, command the LHAs to illuminate at day intensity.	T	T	4.5.19	
102	3.3.2.2.2	Modes	The ON/OFF operation of the PAPI shall be controlled by a three position switch: REMOTE, LOCAL or OFF.	T	T	4.5.19	
103	3.3.2.2.2	Modes	The switch shall select operation as follows: REMOTE allows the remote control input signal (120 VAC, 60Hz) to turn the LHA LEDs on or off; LOCAL turns the LHA LEDs on; and OFF turn the LHA LEDs off.	T	T	4.5.19	
104	3.3.2.2.2	Modes	In both the Remote and the ON positions, the PAPI shall illuminate the LHAs if no fault conditions are detected or shut down the system if faults are detected.	T	T	4.5.19	
105	3.3.2.2.3	Input Power	The 120/240 volt, 60Hz input power lines (with Neutral grounded in accordance with National Electric Code) shall terminate at the power terminal block (3.3.2.4.1),	I		4.5.19	
106	3.3.2.2.3	Input Power	(The 120/240 volt, 60Hz input power lines) shall be connected to internal circuitry of the PCA through a two-pole main circuit breaker (3.3.2.4.2).	I		4.5.19	
107	3.3.2.2.3	Input Power	The system shall have a maximum power consumption of 1.5 KW including any heaters.	T	T	4.5.25	
108	3.3.2.2.3	Input Power	Circuit breakers shall be used to protect any power feeds from the PCA to the LHAs.	I	I		
109	3.3.2.2.3	Input Power	Total Harmonic Distortion of the input voltage waveform shall be not more than 5 percent.	D			
110	3.3.2.2.3	Input Power	The system shall recover automatically (or continue to operate) from momentary power interruptions and brownout conditions where the input voltage dips more	T		4.5.19	

6/16/2009

FAA-E-3007 W/ Change 1

			than 10 percent below nominal.				
111	3.3.2.2.3	Input Power	The PCA shall include a 120VAC Ground Fault Interrupt duplex outlet for connecting maintenance and service equipment.	I	I		
112	3.3.2.2.3	Input Power	The PCA shall include a service lamp, protected by a fuse or circuit breaker, for illuminating the interior of the PCA cabinet during service operations.	I	I		
113	3.3.2.2.4	Fault Conditions	The PCA shall shut down the PAPI if any of the following events are present for at least 10 seconds: any LHA stays in day mode when night mode is selected, an LED out condition as defined in 3.3.1.2.4 occurs, or a tilt fault condition as described in 3.3.1.4.4.2 is detected in an LHA.	D			
114	3.3.2.2.4	Fault Conditions	Loss of communication from any LHA for more than 10 seconds or an LHA not responding properly to a command to shut down (neither night nor day mode active) shall cause the PCA to shut down power to the LHAs.	D			
115	3.3.2.2.4	Fault Conditions	LED indicators or a display inside the PCA shall indicate the initial cause of a system shutdown.	D			
116	3.3.2.2.4	Fault Conditions	If a microprocessor or microcontroller is utilized, a watchdog timer circuit shall be employed to detect a software lockup condition and cause a hardware reset to be issued to the system.	D			
117	3.3.2.2.5	RMS	External signals shall be provided for use by an optional Remote Monitoring System in accordance with section 3.4.1.	I			
118	3.3.2.2.6	Remote Control Input	A Remote Control Input shall be provided to control the PAPI when the main switch is set to the REMOTE position.	T	T	4.5.19	
119	3.3.2.2.6	Remote Control Input	120VAC \pm 10 percent applied to the input shall turn the system on and lack of input shall turn the system off.	T	T	4.5.19	
120	3.3.2.2.6	Remote Control Input	The Remote Control Input connections shall withstand the Dielectric requirements in accordance with 3.12.	T		4.5.11	
	3.3.2.3	Power and Control Assembly Cabinet					
121	3.3.2.3.1	Cabinet Configuration	The PCA cabinet shall contain all the PCA components (3.3.2.4) in one single enclosure, including terminal blocks, cable clamps, grounding lugs, and protective devices.	I			
122	3.3.2.3.1	Cabinet Configuration	The cabinet shall be an outdoor, liquid-tight, National Electrical Manufacturers Association (NEMA-4X) type enclosure.	I			
123	3.3.2.3.1	Cabinet Configuration	All plane surfaces of the control cabinet shall intersect at 90 degrees.	I			
124	3.3.2.3.1	Cabinet Configuration	Access to the interior of the cabinet shall be provided through one hinged door with gasket with provision for padlocking	I			
125	3.3.2.3.1	Cabinet Configuration	The padlock hasp shall have a 7/16 inch (11.1 mm) hole.	I	I		
126	3.3.2.3.1	Cabinet Configuration	The door shall open a minimum of 110 degrees and shall be equipped with a latching mechanism to hold the door in the open position.	I	I		
127	3.3.2.3.1	Cabinet Configuration	The internal face portion of the door shall display a system wiring diagram.	I	I		

6/16/2009

FAA-E-3007 W/ Change 1

128	3.3.2.3.1	Cabinet Configuration	The door of the cabinet shall be bonded to the body of the cabinet in accordance with National Electric Code (NEC) Article 250-90 (2002).	I	I		
129	3.3.2.3.2	Internal Components	All components except the photo sensing device shall be contained inside the cabinet.	I			
130	3.3.2.3.2	Internal Components	There shall be no devices protruding through the walls of the cabinet.	I			
131	3.3.2.3.2	Internal Components	Electronic components shall be mounted on plug-in printed wiring boards or flat mounted printed wiring boards with pluggable connectors in accordance with 3.5.2.	I			
132	3.3.2.3.2	Internal Components	All adjustments located on printed wiring boards shall be readily accessible to the operator.	I			
133	3.3.2.3.2	Internal Components	Adjustments shall be made without the need to use extender cards or cables.	I			
134	3.3.2.3.3	Internal Wiring	Proper high-temperature wire in accordance with National Electric Code Article 310 (see Tables 310-13 and 310-61) shall be used throughout the cabinet.	I			
135	3.3.2.3.3	Internal Wiring	Space shall be provided in the bottom of the cabinet for all wiring (input, output, and internal) and for all terminal blocks.	I	I		
136	3.3.2.3.3	Internal Wiring	An internal ground lug shall be provided in the cabinet for grounding purposes.	I	I		
137	3.3.2.3.3	Internal Wiring	The ground lug shall have a slotted, green-colored head suitable for a No. 6 American Wire Gauge bare copper ground wire.	I	I		
138	3.3.2.3.4	High Voltages	All points that have electrical potentials in excess of 70 VDC or 50VAC shall be shielded by barriers or guards to prevent accidental contact by a service technician.	I	I		
139	3.3.2.3.4	High Voltages	The PCA shall be provided with an interlock to disable power when the door is opened.	D	D		
140	3.3.2.3.4	High Voltages	Interlocks, if used, shall include a mechanical override.	I	I		
141	3.3.2.3.4	High Voltages	In addition, closure of the door shall either reset the override or shall be prohibited if the override is active.	I	I		
	3.3.2.4	Components					
142	3.3.2.4.1	Terminal blocks	One input terminal block of the enclosed base type or DIN rail type, with three screw-pressure terminals, shall be provided for the primary power.	I			
143	3.3.2.4.1	Terminal blocks	For the LHA connections, power connections shall be located on one or more terminal blocks and control and status signals shall be located on different terminal blocks of the enclosed base type or DIN rail type.	I			
144	3.3.2.4.1	Terminal blocks	Terminal blocks shall provide inherently corrosion resistant terminals rated to carry 150% of expected current at 250 VAC.	I			
145	3.3.2.4.1	Terminal blocks	Electrical contact surfaces of terminals shall be brass, bronze, copper or stainless steel that satisfy UL 1059 standard.	I			
146	3.3.2.4.1	Terminal blocks	Pressure screws of the electrical terminals shall be brass, bronze, or stainless steel that satisfy UL 1059 standard.	I			
147	3.3.2.4.1	Terminal blocks	Each pressure- type terminal shall be equipped with a pressure plate to prevent the tip of the screw from	I			

6/16/2009

FAA-E-3007 W/ Change 1

			turning directly on the wire.				
148	3.3.2.4.1	Terminal blocks	The separators shall prevent current leakage under the environmental conditions specified in 3.9.	I			
149	3.3.2.4.1	Terminal blocks	The terminal blocks shall have a dedicated terminal for each conductor, for all internal connections, plus connection of external power cables.	I			
150	3.3.2.4.1	Terminal blocks	External connections shall be made using conductors ranging in size from No. 12 AWG to No. 8 AWG for power wiring and No. 18 or No. 20 AWG for signal wiring.	I			
151	3.3.2.4.1	Terminal blocks	Marking shall be provided in accordance with 3.13.3.	I			
152	3.3.2.4.2	Circuit breaker	A two-pole, molded-case, Thermal-magnetic circuit breaker or electronic solid state type shall be provided as a main circuit breaker and power switch.	I			
153	3.3.2.4.2	Circuit breaker	The circuit breaker shall have an arc quenching chamber and shall have a minimum rating of Asymmetrical interrupting capacity (AIC) of 10,000A(10KA) at 250V, 60Hz as rated by Underwriters Laboratories Standard UL 489.	I		4.5.19	
154	3.3.2.4.3	Photoelectric switching circuitry	A photoelectric switching circuit shall be provided to automatically change the intensity of the lights in two steps as described below.....	T	D	4.5.19	
155	3.3.2.4.3	Photoelectric switching circuitry	All operating components of the switching circuitry, except the photo sensing device (3.3.2.4.4) and any associated signal conditioning circuitry, shall be mounted on a printed wiring board mounted within the cabinet.	I		4.5.19	
156	3.3.2.4.3	Photoelectric switching circuitry	The photoelectric switching circuit shall cause the PCA to set the LHA output to high when the illumination on a vertical surface facing north reaches 58±2 foot-candles (624±21.5 lux),	T	D	4.5.19	
157	3.3.2.4.3	Photoelectric switching circuitry	and shall set the LHA output to LOW when the illumination falls to 35±2 foot-candles (377 ±21.5 lux).	T	D	4.5.19	
158	3.3.2.4.3	Photoelectric switching circuitry	The on-off points shall vary not greater than ±2 foot-candles (±21.5 lux), at any ambient temperature in the range specified in 3.9.1 with line-to-line voltage variations from 230V to 250V.	T		4.5.19	
159	3.3.2.4.3	Photoelectric switching circuitry	Similarly, the on-off points shall vary not greater than 3 foot-candles (32.28 lux) with line-to-line voltage variations from 216V to 230V and from 250V to 264V.	T		4.5.19	
160	3.3.2.4.3	Photoelectric switching circuitry	A symmetrical time delay of 5 to 8 seconds shall be provided to prevent the output current from changing due to transient light conditions.	T		4.5.19	
161	3.3.2.4.3	Photoelectric switching circuitry	A fail-safe feature shall set the output level to the low (night) setting in the event the photo sensing device fails.	D			
162	3.3.2.4.3	Photoelectric switching circuitry	The circuit shall also drive the elapsed time indicator (3.3.2.4.6) when the output is set to HIGH (day) mode.	D			
163	3.3.2.4.4	Photo sensing device	The photo sensing device shall be mounted on the top surface of the PCA cabinet and shall be able to be rotated in any direction so as to point to North and to lock in that position.	D			
164	3.3.2.4.4	Photo sensing	The photo sensing device shall be equipped with a	T		4.5.23	

6/16/2009

FAA-E-3007 W/ Change 1

		device	thermostatically controlled heater to prevent the formation of ice on the lens under all temperature conditions specified for the system.				
165	3.3.2.4.4	Photo sensing device	The photo sensing device shall be mounted in such a way that it will remain clear of up to 6 inches (15.25 cm) of snow accumulated on top of the PCA cabinet.	A			
166	3.3.2.4.4	Photo sensing device	The device itself shall be hermetically sealed, and shall have a spectral response which peaks in the 5500 - 6000 angstroms (0.021 - 0.023 mil) region.	I			
167	3.3.2.4.4	Photosensing device	The device shall meet the temperature requirements of the photoelectric switching circuitry (3.3.2.4.3).	I			
168	3.3.2.4.4	Photosensing device	The device shall activate the photoelectric switching circuitry (3.3.2.4.3).	I			
169	3.3.2.4.5	Power Supply	A power supply shall be provided to supply the proper voltages and currents necessary to operate the PCA circuits within the tolerances and conditions set forth in this specification.	I			
170	3.3.2.4.5	Power Supply	Wherever practicable, all electronic components shall be mounted on a plug-in printed wiring board mounted within the cabinet.	I			
171	3.3.2.4.5	Power Supply	The power supply and all associated wiring shall be designed to withstand the dielectric requirements in accordance with 3.12.	T		4.5.11	
172	3.3.2.4.6	Elapsed time indicator	An elapsed time indicator shall be provided to register the number of hours of operation during the high-intensity setting.	D	D		
173	3.3.2.4.6	Elapsed time indicator	The meter shall indicate total time in hours and tenths of hours.	I			
174	3.3.2.4.6	Elapsed time indicator	The meter shall be recyclable and shall have a minimum indicator range of 50,000 hours.	I			
175	3.3.2.4.6	Elapsed time indicator	The meter shall be mounted within the cabinet.	I			
176	3.3.2.5	Power and control assembly finish	All exterior and interior surfaces of the power and control assembly shall be finished as described in 3.8.1, with Aviation White, Color No. 17875 (in accordance with FED-STD-595) except that aluminum surfaces that are clear anodized in accordance with MIL-A-8625, Type II do not require painting.	I	I		
	3.3.3	Aiming Instrument Set and Calibration Bar					
177	3.3.3	Aiming Instrument Set and Calibration Bar	The Aiming Instrument Set shall consist of a clinometer, a calibration bar, and a portable storage case.	I	I		
178	3.3.3.1	Clinometer	The clinometer shall be used to accurately adjust the LHA during cross-leveling (lateral), longitudinal leveling, and elevation setting.	T	T	4.5.15	
179	3.3.3.1.1	Construction	The base of the clinometer shall be rustproof.	I			
180	3.3.3.1.1	Construction	The clinometer shall be constructed of inherently corrosion resistant metal to provide a 10 lbs (4.5kg) maximum rugged instrument.	I			
181	3.3.3.1.1	Construction	Aluminum and other soft metals shall not be used where subject to metal-to-metal rubbing.	I			

6/16/2009

FAA-E-3007 W/ Change 1

182	3.3.3.1.1	Construction	Design and construction of the clinometer shall be such that deviation from true position due to its own weight shall be not greater than 3 minutes of arc when the clinometer is placed on the optical bench (3.3.1.3.1.3).	D			
183	3.3.3.1.1	Construction	The clinometer shall be designed so that repeated changing of the dial setting will not cause excessive wear that could deteriorate the accuracy of the instrument.	I			
184	3.3.3.1.2	Level	The clinometer shall utilize a 6-inch (15.24 cm) (maximum) level having an accuracy of ± 2 minutes.	I			
185	3.3.3.1.2	Level	The level shall be permanently attached to the clinometer to permit fine adjustments to calibrate the instrument.	I			
186	3.3.3.1.2	Level	The level shall have a protective device to minimize possible damage.	I			
187	3.3.3.1.3	Dial	An accurate direct-reading dial or micrometer type indicator shall be provided for setting the LHA to the desired angle.	I			
188	3.3.3.1.3	Dial	The reading dial shall indicate at minimum, angles from 1.5 degrees to 6 degrees in graduated increments of minutes of arc.	I			
189	3.3.3.1.3	Dial	The spacing between each degree mark shall be at least 1/2 inch (12.7 mm).	I			
190	3.3.3.1.3	Dial	A 0.00 degree setting shall be provided on the dial for calibration purposes and shall have an accuracy of ± 2 minutes of arc and a repeatability of ± 1 minute of arc while on the calibration bar. Alternate designs using a vernier dial may be used, so long as the vernier dial is provided with equivalent graduations as specified for the direct reading dial.	I			
191	3.3.3.1	Dial	The clinometer shall have provisions for firmly securing the dial setting after factory calibration, but shall permit field adjustment to the 0.00 degree position by the user.	D			
192	3.3.3.2	Calibration Bar	A calibration bar shall be provided with each clinometer to permit field checking and calibration.	I	I		
193	3.3.3.2	Calibration Bar	The calibration bar shall be designed for laying on a flat surface or in the carrying case (see 3.3.3.3) and shall have adjustment features to permit it being leveled to a horizontal plane.	I			
194	3.3.3.2	Calibration Bar	The tolerance for the flatness of the calibration bar shall be ≤ 0.005 inches.	I			
195	3.3.3.2	Calibration Bar	A portable level, not attached to the bar, shall be provided with each calibration bar to permit leveling.	I			
196	3.3.3.2	Calibration Bar	The level shall have a metal base meeting the requirements of paragraph 3.6.1.	I			
197	3.3.3.2	Calibration Bar	The level shall be used to verify the calibration of the clinometer.	I			
198	3.3.3.3	Carrying and storage case.	A rigid portable inherently corrosion resistant metal, fiberglass or shatterproof plastic case shall be provided for carrying and storing the clinometer.	I	I		
199	3.3.3.3	Carrying and storage case.	The case shall have a carrying handle and shall have a suitable latch for securing the cover in the closed position.	I	I		
200	3.3.3.3	Carrying and	The interior shall be designed to accommodate the	I	I		

6/16/2009

FAA-E-3007 W/ Change 1

		storage case.	clinometer so that it will be held and cushioned firmly in place.				
201	3.3.3.3	Carrying and storage case.	The case shall also carry and store the calibration bar and portable level.	I	I		
202	3.3.3.3	Carrying and storage case.	The aiming instrument set carrying case shall have an instruction plate installed on the inside of the cover in a location easily viewed by the user and shall contain all necessary instructions for calibration and use of the aiming instrument set.	I	I		
203	3.3.3.3	Carrying and storage case.	The instruction plate shall be made of aluminum.	I			
204	3.3.3.3	Carrying and storage case.	The plate shall conform to the requirements of 3.6.5.	I			
205	3.4	Monitored points and controls	Test points shall be provided on all signals that are required to be monitored during checkouts, alignment, and calibration, or during preventive maintenance procedures.	I			
206	3.4	Monitored points and controls	Test points shall not be located in compartments with voltage points of 500 volts or more, and all test points shall be located so as to preclude accidental shock to personnel engaged in normal operating or maintenance activities.	I			
207	3.4	Monitored points and controls	The removal of components, modules, or circuit cards shall not be required to gain access to test points or adjustments.	D			
208	3.4	Monitored points and controls	Test point controls and indicators mounted on printed wiring boards that are installed in a card cage shall be accessible from the front of the circuit cage assembly without the use of extender boards.	D			
209	3.4.1	External Signals	Monitored items/test points shall be brought out to a port on a card or backplane for possible connection to a future Remote Monitoring System (RMS).	I			
	3.5	Electrical components					
210	3.5.1	Electrical connectors	Electrical connectors shall be in accordance with FAA-G-2100 section 3.3.1.4.3.	I			
211	3.5.2	Printed wiring boards	Printed wiring boards, assemblies and components mounting shall conform to FAA-G-2100, paragraphs 3.2.2.1 and 3.2.2.2, with the exception of paper base copper-clad laminates which are prohibited.	I			
212	3.5.2	Printed wiring boards	Conformal coating is required and shall be in accordance with FAA-G-2100 paragraph 3.3.1.4.7b.	I			
213	3.5.3	Component ratings	When component ratings are not specified, they shall be selected to ensure that the components are not operated in excess of 80 percent of their normally de-rated maximum values for the temperatures encountered under the specified equipment environmental conditions.	I			
214	3.5.3	Component ratings	De-rating of electronic components shall be in accordance with MIL-HDBK--454, Requirement 18.	A			
215	3.5.4	Fiber Optics	Any fiber optics used in the PAPI shall conform to FAA-STD-049.	I			
216	3.6	Materials and parts	Materials and parts shall be as specified herein.	I			
217	3.6	Materials and parts	Materials and parts not specifically designated by standard, or specification shall meet the requirements of FAA-G-2100 Section 3.3.1.	I			

6/16/2009

FAA-E-3007 W/ Change 1

218	3.6	Materials and parts	All materials and parts shall be suitable for operation under the environmental conditions in accordance with 3.9.	D			
219	3.6.1	Metals	Metals shall be inherently corrosion resistant.	I			
220	3.6.1	Metals	The use of dissimilar metals shall be in accordance with MIL-STD-889. Parts may be suitably coated to prevent corrosion or seizing of parts that require removal for servicing.	I			
221	3.6.2	Aluminum	Aluminum shall be in accordance with American Society for Testing and Materials (ASTM) B241, B221 and B211.	I			
222	3.6.2	Aluminum	Aluminum alloy plate and sheet, aluminum alloy die castings, and aluminum alloy sand castings shall be in accordance with ASTM B 209, B26, B108, and B85.	I			
223	3.6.3	Optical covers	Light transmitting covers shall be free of bubbles.	I			
224	3.6.4	Gaskets	Gaskets used at separable joints for cushioning and sealing purposes shall be made of neoprene and shall be suitable for use at ambient temperatures of -67°F (-55°C) to +149°F (+65°C)	I			
225	3.6.5	Nameplates	Nameplates conforming to FAA-E-2100 paragraph 3.3.3.1 shall be installed at convenient locations on the LHA, the power and the control assembly, and the clinometer carrying and storage case, if applicable.	I			
226	3.6.5	Nameplates	Each nameplate shall be attached to each assembly with four aluminum rivets or drive screws.	I			
227	3.7	Interchangeability	All parts of the unit furnished under a single procurement shall be manufactured to a tolerance that shall permit interchangeability of any part with like part of any other unit.	I			
228	3.7	Interchangeability	Identical components shall be identified with identical parts numbers and unlike parts shall not have the same part number.	I			
229	3.7	Interchangeability	Interchangeability shall be in accordance with MIL-HDBK-454, Requirement 7.	I			
	3.8	Finishes					
230	3.8.1	Paint	All aluminum exterior and interior surfaces shall be pretreated with a chemical film in accordance with MIL-C-5541, Class 1A or MIL-STD 8625, and shall be sprayed with one coat of zinc chromate primer in accordance with Federal Specification No. TT-P-1757, composition L, color Y. Alternatively, the housing may be black anodized per MIL-A-8625 in lieu of painting the interior and prior to painting the exterior.	I			
231	3.8.1	Paint	Surfaces to be painted shall be painted with not less than a primer coat and a finish coat in accordance with Master Painters Institute reference #49, in the specified color. The paint shall be applied to at least 2.5 mils (63.5 microns) thickness and the final painted surfaces shall be free of blotches, scratches, and runs. . As an alternative to painting, powder coating may be used. The baked film shall have a minimum thickness of 2.5 mils (63.5 microns) and there shall be no areas where substrate shows through the coating. Alternative finishing methods that provide the same level	I			

6/16/2009

FAA-E-3007 W/ Change 1

			of protection or greater may be used upon approval of the purchasing authority.				
232	3.8.1	Paint	Leaded paint or paints containing isocyanates or hazardous substances shall not be used.	I			
			Environmental Requirements				
233	3.9.1	Temperature	The temperature range shall be from -40°F (-40°C) to +149°F (+65°C)	T		4.5.3	T
234	3.9.1	Temperature	The clinometer (par 3.3.3.1) shall meet all the performance requirements of 3.7.1 when operated over this temperature range.	D			
235	3.9.2	Altitude	The pressure altitude shall range from -300 feet (-91.44 meters) to 10,000 feet (3,048 meters).	T		4.5.8	
236	3.9.3	Temperature Shock (Thermal Shock)	The LHA external surfaces (including projection lenses) shall be exposed to a sudden application of cold water at a temperature of 32°F to 41°F (0° to +5 °C) when the LHAs reach stable temperature.	T		4.5.7	T
237	3.9.4	Humidity	Relative humidity shall be up to 100 percent, including conditions where condensation takes place in the form of both water and frost.	T		4.5.4	
238	3.9.5	Sand and Dust	The system shall tolerate windblown dust particles of 20±5µm mean diameter blowing at 1750 ft.min (8.9m/s) and sand particles of 150 to 850 µm blowing at 3540 ft/min (18 m/s)	T		4.5.6	
239	3.9.6	Rain	The system shall be capable of withstanding windblown rain at a rate of 6 in/hr (1.6 mm/min) at wind speeds of 40 mph (18 m/sec).	T		4.5.5	
240	3.9.7	Salt Spray	The system shall be capable of withstanding salt-laden atmosphere with relative humidity as stated in 3.9.4. The salt spray shall have a concentration of 5% sodium chloride, by weight.	T		4.5.9	
241	3.9.8	Solar radiation (sunshine)	The system shall be capable of withstanding sunshine intensity of 1120 W/M ² (355 BPH ³) with spectral components as defined in table 505.4A-1 of MIL-STD-810 with ambient temperatures as stated in 3.9.1 of this document.	T		4.5.10	T
242	3.9.9	Vibration	The LHAs and the PCA shall be capable of withstanding vibrations in the frequency range of 10 to 2,000 Hertz.	T		4.5.12	
243	3.9.10	Ice Accumulation	The LHA shall be designed to prevent the accumulation of ice on the face of the lenses when exposed to an air temperature of 14°F (-10°C) and water droplet temperature of 32°F to 37.4°F (0°C to 3°C).	T		4.5.23	
244	3.10	Transient suppression	Transient suppression devices shall be provided for all power lines at their first point of interface with the equipment.	I			
245	3.10	Transient suppression	The return for the lightning transient protection devices shall be connected to earth ground via a separate dedicated ground lug that will accommodate not less than a No. 6 AWG conductor.	I			
246	3.10	Transient suppression	Transient protection shall also be included for signal and power lines that interconnect the PCA and the LHAs.	I			
247	3.10	Transient suppression	The transient protection for signal lines and the LHA power lines shall be in accordance with FAA-STD-019 Lighting and Surge Protection, Grounding, Bonding, and shielding Requirements for Facilities and Electronic Equipment	I			

6/16/2009

FAA-E-3007 W/ Change 1

248	3.10.1	Transient Waveforms	The equipment shall be designed to suppress switching transients, and to withstand transient increases superimposed on the 120/240 V ac (rms) power line input voltage that reach a peak value of 500 V for as long as 50 milliseconds.	T		4.5.12	
249	3.10.1	Transient Waveforms	In addition, the equipment shall be designed to withstand lightning transients superimposed on each input power line.	T		4.5.12	
250	3.10.2	Parameters	Equipment performance and operational functions shall not be degraded beyond the specification requirements by the above transients when each type of transient is superimposed a minimum of five times on each power input terminal while the equipment is energized.	T		4.5.12	
	3.11	Electromagnetic Interference Control					
251	3.11.1	Conducted Emissions	Conducted interference levels on incoming ac power leads, control leads, and signals leads shall be not greater than the limits for CE102 as defined in MIL-STD-461 using a frequency range of 10Khz to 10MHz.	T		4.5.13	
252	3.11.2	Radiated Emissions	Radiated emission shall be no greater than the limit for RE102 of MIL-STD-461 using a frequency range of 2MHz to 1GHz..	T		4.5.13	
253	3.11.3	Conducted Susceptibility	Conducted Susceptibility of the system shall be in compliance with CS114 of MIL-STD-461. The frequency range shall be 10 kHz to 200 MHz, and Curve #2 of Figure CS114-1 of MIL-STD-461E shall be used for the limit IAW Table III for Navy ground equipment.	T		4.5.13	
254	3.11.4	Radiated Susceptibility	Radiated Susceptibility of the system shall be in compliance with RS103 of MIL-STD-461. The frequency range shall be 2 MHz to 18 GHz. The electric field intensity shall be in accordance with the limits for Navy ground equipment to Table VII RS103 limits for Navy ground equipment of MIL-STD-461.	T		4.5.13	
	3.12	Electrical Safety					
255	3.12.1.1	Dielectric Strength; Power Leads	The PAPI shall be designed to withstand a voltage of 1500VAC Peak value applied between the AC input of the system and chassis ground without any arc-over. Transient suppression devices and EMI filters that are connected to input power are not required to survive this level and may be disconnected for test purposes. Note that this is a SYSTEM requirement and that power leads the go from the PCA to the LHAs must also pass this requirement.	T		4.5.11.1	
256	3.12.1.2	Dielectric Strength; Remote Control Input	The Remote Control input shall be designed to withstand a voltage of 500VAC Peak value applied between it and the chassis ground without any arc-over. Transient suppression devices and EMI filters that are connected to the Remote Control Input are not required to survive this level and may be disconnected for test purposes.	T		4.5.11.1	
257	3.12.2	Ground Bonding	Safety ground connections to equipment chassis shall have less than 1 milli-ohm of resistance.	T		4.5.11.2	
	3.13	Assembly, Wiring and					

6/16/2009

FAA-E-3007 W/ Change 1

		Marking					
258	3.13.1	Assembly	Assembly of all units shall be in a permanent manner with the components accessible for servicing, replacement, or repairs.	I			
259	3.13.1	Assembly	Bolts used in assembling units shall be equipped with captive nuts;	I			
260	3.13.1	Assembly	Bolt lengths shall be chosen so that at least three full threads will show over the nut after tightening.	I			
261	3.13.1	Assembly	Lock washers of the internal tooth type shall be used on all bolts where good electrical continuity is required for grounding.	I			
262	3.13.1	Assembly	The chassis shall not be used as a current-carrying part of the electrical circuitry.	I			
263	3.13.2	Wiring	Connecting wires shall be copper and shall have the proper insulation rating and be of adequate AWG size for the application, as specified in National Electric Code Article 310	I			
264	3.13.2	Wiring	Unless otherwise specified, the wires and wiring shall conform to the National Electrical Code for panel-board wiring.	I			
265	3.13.2	Wiring	Wire bends with short radii shall be taken in such a way as to avoid nicking or cutting the conductors.	I			
266	3.13.2	Wiring	Wire that interfaces to external signals shall be chosen to also meet the dielectric strength requirements of section 3.12.	T		4.5.11	
267	3.13.3	Marking	All equipment components shall be clearly identified by nameplates or bold permanent type stencils.	I	I		
268	3.13.3	Marking	Identification markings shall agree with designations on the wiring diagram and parts list.	I			
269	3.13.3	Marking	All control wires shall be provided with end identification in the form of a plastic band around the wire with identifying markings permanently stamped thereon, by markings permanently stamped into the wire itself, or other methods upon approval of the purchasing authority.	I			
270	3.13.3	Marking	All power conductors shall be similarly marked, except that a permanently stamped rigid laminate tag may be attached near the cable ends in lieu of the above.	I			
271	3.13.3	Marking	The terminating points for all wires and cables at terminal blocks, as well as the terminal blocks, shall be clearly identified.	I			
272	3.13.3	Marking	The identification shall correspond to the circuit and terminal designations as shown on the interconnection wiring diagram and on applicable diagrams contained in the instruction book	I			
273	3.14	Workmanship	Workmanship shall be in accordance with MIL-HDBK-454, Requirement 9.	I			
274	3.15	Brazing	Brazing shall be in accordance with MIL-HDBK-454, Requirement 59, except that electrical connections shall not be brazed.	I			
275	3.16	Soldering	Soldering shall be in accordance with MIL-HDBK-454, Requirement 5.	I			
	3.17	Maintainability					
	3.17.1	Maintainability design criteria					

6/16/2009

FAA-E-3007 W/ Change 1

276	3.17.1 (a)	Maintainability design criteria	Mean time to repair (MTTR) - the PAPI shall have a MTTR of not more than 30 minutes and 99% of all repair times shall be less than two (2) hours. The contractor will demonstrate conformance of this requirement by performing maintainability analysis by using MIL-HDBK-472 as guidance.	A	D		
277	3.17.1 (b)	Maintainability design criteria	Mean periodic maintenance time (MPMT)- The PAPI MPMT shall be not greater than 2 hours per 3 months, including routine inspection.	A			
	3.18	Reliability Design Criteria					
278	3.18.1	System reliability parameters	Mean Time Between Failures (MTBF) of the system, shall be not less than 7,000 hours.	A&T		TBD in Statement of work	
279	3.19	Expected Life of Product	The PAPI shall be designed for an expected life-span of twenty (20) years minimum under the environmental conditions specified in section 3.9	A			
280	3.19	Expected Life of Product	This is to be interpreted to mean that the enclosures, mounting components and major structural parts shall be designed to maintain the aiming accuracies specified in section 3.2 for this period.	A			
281	3.19	Expected Life of Product	Optical components shall be designed to maintain the light intensity required in section 3.2.2 by the use of periodic cleaning (no removal and reconditioning required).	A			
282	3.20	Software	If software or firmware is developed for the PAPI system, it shall conform to FAA-STD-026.	I			

9/30/2008

FAA-E-3007

APPENDIX B NAS-SS-1000 Requirements Trace

NAS-SS-1000 Paragraph	Requirement	FAA-E-XXXX Paragraph	Comments
3.2.1.4.9	Precision approach path indicator (PAPI). The PAPI will provide visual descent guidance for a non-precision approach to a runway. The requirements for the PAPI shall be stated in the following subparagraphs:	3.1	
3.2.1.4.9.1	<u>Functional characteristics.</u> The PAPI shall provide the following functions:	N/A	
3.2.1.4.9.1.1	<u>Service.</u> The PAPI shall provide visual descent guidance that assures safe obstruction clearance to the pilot along a fixed single glide path to the touchdown point on a non-precision approach runway.	3.1	
3.2.1.4.9.1.2	<u>Operational control.</u> The PAPI shall respond to operational control (on/off) from the ATCT.	3.3.2.2.6	
3.2.1.4.9.1.3	<u>Radio control.</u> The PAPI shall respond to air-to-ground VHF/UHF radio control (on) at unmanned airports.		Requirement is in Radio Remote Control System (RRCS)
3.2.1.4.9.1.4	<u>Automatic operation.</u> The PAPI shall be capable of adjusting its intensity automatically in response to ambient lighting conditions.	3.3.2.2 & 3.3.2.4.3	
3.2.1.4.9.1.5	<u>Automatic shutdown.</u> The PAPI shall automatically turn off after a specified period following activation by a VHF/UHF aircraft transmitter.		Requirement is in Radio Remote Control System (RRCS)
3.2.1.4.9.1.6	<u>Maintenance monitoring.</u> The PAPI shall implement the maintenance monitoring functional characteristics as specified in 3.2.1.1.1.1 of Volume V of the NAS-SS-1000.		RMS requirements have been waived per AAF-1 memorandum dated February 3, 2003

9/30/2008

FAA-E-3007

3.2.1.4.9.1.7	<u>Maintenance and status data.</u> The PAPI link control unit (when installed) shall collect and transmit maintenance and status data from the PAPI.		RMS requirements have been waived per AAF-1 memorandum dated February 3, 2003
3.2.1.4.9.2	<u>Performance characteristics.</u> The PAPI shall meet the following performance characteristics:	N/A	
3.2.1.4.9.2.1	<u>Duration.</u> The PAPI shall remain activated for 15 minutes after responding to radio control from an aircraft.		Requirement is in A/G Receiver
3.2.1.4.9.2.2	<u>Intensity.</u> The PAPI shall have 2 brightness steps with relative intensities of 100 percent (day use) and 8.5 percent (night use).	3.2.2 & 3.3.2.4.3	
3.2.1.4.9.2.3	<u>Effective range.</u> The PAPI shall have an effective visual range during clear weather of at least 3 miles during the day and 20 miles at night.	3.2.2 & Fig. 3	These intensities have been chosen to produce the desired visibility.
3.2.1.4.9.2.4	<u>Glide path angle.</u> The PAPI shall be adjustable to provide visual glide path guidance between glide path angles of 1.5 to 6.0 degrees.	3.3.1.3.4.1	
3.2.1.4.9.2.5	<u>Lateral coverage.</u> The PAPI shall provide usable visual approach guidance out to at least ± 10 degrees either side of the extended runway centerline.	Figure 3	
3.2.1.4.9.2.6	<u>Automatic intensity selection.</u> When in automatic mode, the PAPI shall operate at: High intensity when the illumination on a vertical surface facing north exceed 58 ± 2 foot candles; Low intensity when the illumination drops to 35 ± 2 foot candles.	3.3.2.1 & 3.3.2.4.3	
3.2.1.4.9.3	<u>Functional/physical interfaces.</u> The PAPI shall interface functionally and physically as shown in Figure 3.2.1.4.9.3-1. The PAPI functional interfaces are defined in Table 3.2.1.4.9.3-1.		The signals defined in table 3.2.1.4.9.3-1 are RMS.

9/30/2008

FAA-E-3007

End of Document.