

TM 1-320

WAR DEPARTMENT

TECHNICAL MANUAL

of

AIRSHIP AERODYNAMICS

February 11, 1941

AIRSHIP AERODYNAMICSPrepared under direction of
Chief of the Air Corps

SECTION		Paragraph
I.	General.	
	Definition of aerodynamics-----	1
	Purpose and scope-----	2
	Importance-----	3
	Glossary of terms-----	4
	Types of airships-----	5
	Aerodynamic forces-----	6
II.	Resistance.	
	Fluid resistance-----	7
	Shape coefficients-----	8
	Coefficient of skin friction-----	9
	Resistance of streamlined body-----	10
	Prismatic coefficient-----	11
	Index of form efficiency-----	12
	Illustrative resistance problem-----	13
	Scale effect-----	14
	Resistance of completely rigged airship-----	15
	Deceleration test-----	16
III.	Power requirements.	
	Power required to overcome airship resistance-----	17
	Results of various speed trials-----	18
	Burgess formula for horsepower-----	19
	Speed developed by given horsepower-----	20
	Summary-----	21
IV.	Stability.	
	Variation of pressure distribution on airship hull-----	22
	Specific stability and center of gravity of air- ship-----	23
	Center of buoyancy-----	24
	Description of major axis of airship-----	25
	Types of stability-----	26
	Forces and moments acting on airship-----	27
	Damping moment-----	28
	Longitudinal stability-----	29
	Directional stability-----	30
	Lateral stability-----	31
	Summary-----	32

*This manual supersedes TR 1170-290, November 15, 1929.

SECTION		Paragraph
V.	Control.	
	General types.....	33
	Directional	34
	Altitude	35
	Reverse.....	36
	Application of dynamic control to operation of airships.....	37
VI.	Aerodynamic stress.	
	Assumption as to condition of maximum stress..	38
	Transverse forces acting on airship flying at constant angle of pitch.....	39
	Transverse forces acting on airship in steady turn.....	40
	Forces caused by gusts.....	41
	Empirical formulas for maximum aerodynamic bending moment on hull and for forces on tail surfaces	42
	Method of calculating shear and bending mo- ment on hull.....	43
	Conclusion.....	44

SECTION I

GENERAL

	Paragraph
Definition of aerodynamics.....	1
Purpose and scope.....	2
Importance	3
Glossary of terms.....	4
Types of airships.....	5
Aerodynamic forces.....	6

1. Definition of aerodynamics.—Aerodynamics is that branch of dynamics which treats of the motion of air and other gaseous fluids, and of the forces on solids in motion relative to such fluids.

2. Purpose and scope.—This manual is designed as a text for the instruction of airship student pilots and as a reference text for the rated pilot. Accordingly the subject has been so approached as to give the knowledge of aerodynamics essential to the operation of airships. Intricate formulas involving higher mathematics, although valuable to the designer, are of secondary importance to the pilot. Such formulas therefore have been omitted and the entire subject so treated as to bring out basic principles and their application to lighter than air aircraft operation.

3. Importance.—Airships are controlled in two ways, statically and dynamically. The former method is discussed in TM 1-325 and will be mentioned but incidentally in this manual. Because of the existence of static means of control, the study of aerodynamics may appear of minor importance to the operation of airships. This is untrue. Stability and control are constantly effected by a combination of static and dynamic forces. To insure safety of the airship and to preclude possibility of exposing it to dangerous conditions, the pilot must be aware of existing dynamic forces and their effects on the airship itself and on its flight path. Frequently airships, due to unavoidable causes such as leakage of gas or accumulation of moisture, have become statically uncontrollable but have been saved by the intelligent application of dynamic means of control.

4. Glossary of terms.—During recent years many terms have been introduced into the English language covering various aspects of aeronautical science. Report No. 240, National Advisory Committee for Aeronautics, defines the meaning of the most common of these expressions, from which most of the following definitions have been abstracted:

Aerodynamics.—Branch of dynamics which treats of the motion of air and other gaseous fluids and of the forces acting on solids in motion relative to such fluids.

Aeronautics.—Science and art pertaining to the flight of aircraft.

Aerostat.—Generic term for aircraft whose support is chiefly due to buoyancy derived from aerostatic forces. The immersed body consists of one or more bags, cells, or other containers filled with a gas which is lighter than air.

Airfoil.—Any surface designed to be projected through the air in order to produce a useful dynamic reaction.

Airfoil section (or profile).—Cross section of an airfoil made by a plane parallel to a specified reference plane. A line perpendicular to this plane is called the axis of the airfoil.

Air scoop.—Projecting scoop which uses the wind or slipstream to maintain air pressure in the interior of the ballonnet of an aerostat.

Airship.—Aerostat provided with a propelling system and with means of controlling the direction of motion. When its power plant is not operating it acts like a free balloon.

Nonrigid.—Airship whose form is maintained by the internal pressure in the gas bags and ballonets (fig. 1).

Rigid.—Airship whose form is maintained by a rigid structure (fig. 3).

Semirigid.—Airship whose form is maintained by means of a rigid or jointed keel in conjunction with internal pressure in the gas containers and ballonets (fig. 2).

The term "airship" is sometimes incorrectly applied to heavier than air aircraft either in full or as "ship." This is a slang use of the word and should be avoided.

Air speed.—Speed of an aircraft relative to the air. Its symbol is V .

Angle, critical.—Angle of attack at which the flow about an airfoil changes abruptly with corresponding abrupt changes in lift and drag.

Angle, elevator.—Angular displacement of elevator from neutral position. It is positive when trailing edge of the elevator is below neutral position.

Angle of attack.—Acute angle between the chord of an airfoil and its direction of motion relative to the air. (This definition may be extended to other bodies than airfoils.) Its symbol is α .

Angle of pitch.—Acute angle between two planes defined as follows: One plane includes lateral axis of the aircraft and direction of the relative wind; the other plane includes lateral axis and longitudinal axis. (In normal flight the angle of pitch is the angle between longitudinal axis and direction of relative wind.) This angle is denoted by θ and is positive when nose of the aircraft has risen.

Angle of roll, or angle of bank.—Acute angle through which aircraft must be rotated about its longitudinal axis in order to bring its lateral axis into a horizontal plane. This angle is denoted by Φ and is positive when the left wing is higher than the right.

Angle of yaw.—Acute angle between direction of relative wind and plane of symmetry of an aircraft. This angle is denoted by Ψ and is positive when the aircraft has turned to the right.

Angle, propeller blade.—Actual angle between chord of propeller section and plane perpendicular to axis of rotation of propeller. Usually called "blade angle."

Angle, rudder.—Acute angle between rudder and plane of symmetry of the aircraft. It is positive when trailing edge has moved to the left with reference to normal position of pilot.

Angle, zero lift.—Angle of attack of an airfoil when its lift is zero.

Aspect ratio of propeller blade.—Half the ratio of propeller diameter to maximum blade width.

Axes of aircraft.—Three fixed lines of reference, usually centroidal and mutually perpendicular. The longitudinal axis in the plane

of symmetry, usually parallel to axis of the propeller, is called the longitudinal axis; the axis perpendicular to this in the plane of symmetry is called the normal axis; and the third axis perpendicular to the other two is called the lateral axis. In mathematical discussions, the first of these axes, drawn from front to rear, is called the X axis; the second, drawn upward, the Z axis; and the third, running from right to left, the Y axis.

Ballast.—Any substance, usually sand or water, carried in a balloon or airship and intended to be thrown out, if necessary, for the purpose of reducing load carried and thus altering aerostatic relations.

Ballonet.—Compartment of variable volume constructed of fabric or partitioned off within the interior of a balloon or airship. It is usually partially inflated with air under control of valves from a blower or from an air scoop. By blowing in or letting out air, it serves to compensate for changes of volume in gas contained in the envelope and to maintain gas pressure, thus preventing deformation or structural failure. By means of two or more ballonets, often used in nonrigid airships, the trim can also be controlled. The ballonet should not be confused with gas cell.

Blade back.—Side of propeller blade which corresponds to upper surface of an airfoil.

Blade face.—Surface of propeller blade which corresponds to lower surface of an airfoil. Sometimes called “thrust face” or “driving face.”

Blade width ratio.—Ratio of developed width of propeller blade at any point to circumference of a circle whose radius is the distance of that point from the propeller axis.

Bow stiffener.—Rigid member attached to bow of nonrigid or semi-rigid envelope to reinforce it against pressure caused by motion of the airship. Sometimes called “nose stiffener” or “nose batten.”

Buoyancy.—Upward air force on aerostat which is derived from aerostatic conditions. It is equal to weight of air displaced.

Buoyancy, center of (aerostat).—Center of gravity of volume of contained gas.

Camber.—Rise in curve of an airfoil section from its chord, usually expressed as ratio of departure of the curve from the chord to the length of the chord. “Upper camber” refers to the upper surface of an airfoil and “lower camber” to the lower surface; “mean camber” is the mean of these two.

Capacity.—Volume of the gas-containing portion of an aerostat.

Car.—That portion of an airship intended to carry power unit or units,

personnel, cargo, or equipment. It may be suspended from the buoyant portion or it may be built close up against it. It is not to be applied to parts of the keel of a rigid or semirigid airship which have been fitted for the purposes mentioned.

Ceiling, static.—Altitude in standard atmosphere at which an aerostat is in static equilibrium after removal of all dischargeable weights.

Center of pressure coefficient.—Ratio of distance of center of pressure from leading edge to chord length.

Center of pressure of airfoil section.—Point in chord of airfoil section, prolonged if necessary, which is at the intersection of the chord and the line of action of the resultant air force. Abbreviation is C. P.

Chord (of airfoil section).—Line of straightedge brought into contact with lower surface of the section at two points; in the case of an airfoil having double convex camber, the straight line joining the leading and trailing edges. (These edges may be defined for this purpose as the two points in the section which are farthest apart.) The line joining leading and trailing edges should be used also in those cases in which lower surface is convex except for a short flat portion. The method used for determining the chord should always be explicitly stated for those sections concerning which ambiguity seems likely to arise.

Chord length.—Length of projection of airfoil section on its chord. Its symbol is c .

Controls.—General term applied to means provided to enable the pilot to control speed, direction of flight, altitude, and power of aircraft.

Drag.—Component parallel to relative wind of total air force on aircraft or airfoil. Its symbol is D .

Dynamic (or impact) pressure.—Product $\frac{1}{2}\rho V^2$, where ρ is density and V is relative speed of the air. It is the quantity measured by most air speed instruments. Its symbol is q .

Elevator.—Movable auxiliary airfoil, function of which is to impress pitching moment on the aircraft. The elevator is usually hinged to the stabilizer.

Envelope.—Outer covering of aerostat, usually of fabric. It may or may not be also the gas container. It may be divided by diaphragms into separate gas compartments or cells, and it may also contain internal air cells or ballonets.

Flight path.—Path of center of gravity of aircraft with reference to the earth.

Horsepower of engine, maximum.—Maximum horsepower engine can develop.

Horsepower of engine, rated.—Average horsepower developed by an engine of a given type in passing the standard 50-hour endurance test.

Hull (airship).—Main structure of a rigid airship consisting of a covered elongated framework which incloses gas cells and supports cars and equipment. May also be applied to complete buoyant unit of any aerostat. In this latter sense sometimes called "gas bag."

Indraft (inflow).—Flow of air from in front of propeller into blades.

Keel (airship).—Assembly of members at bottom of hull of semi-rigid or rigid airship which provides special strength to resist hogging and sagging and also serves to distribute effect of concentrated loads along the hull. It may be a simple Gall's chain as in some semirigids, or a very extensive structure inclosing the corridor as in most rigids.

Leading edge.—Foremost edge of airfoil or propeller blade. Also called "entering edge."

Lift.—That component of total air force on aircraft or airfoil which is perpendicular to relative wind and in plane of symmetry. It must be specified whether this applies to complete aircraft or to parts thereof. In the case of an airship this is often called "dynamic lift." Its symbol is L .

Lift, gross (airship).—Lift obtained from volume of buoyant gas equal to nominal gas capacity of the aircraft. Obtained by multiplying nominal gas capacity by lift per unit volume of gas used for inflation.

Lift, static (aerostat).—Resultant upward force on an aerostat at rest obtained by multiplying actual volume of the air displaced by density of the air and subtracting weight of contained gas. (The volume of the air displaced multiplied by the difference of density of the air and the contained gas.)

Load:

Dead.—Structure, power plant, and fixed equipment of an aircraft. Included in this fixed equipment are water in radiator and cooling system, all essential instruments and furnishings, fixed electric wiring for lighting, heating, etc. In the case of the aerostat the amount of ballast which must be carried to assist in making a safe landing must also be included.

Full.—Weight empty plus useful load. Also called "gross weight."

Pay.—That part of useful load from which revenue is derived, namely, passengers and freight.

Useful.—Crew and passengers, oil and fuel, ballast other than emergency, ordnance, and portable equipment.

Nose heavy.—Condition of an airship which when at rest in still air trims with its axis inclined down by the bow. The term “bow heavy” is preferred to “nose heavy” in describing airships.

Oscillation, stable.—Oscillation whose amplitude does not increase.

Oscillation, unstable.—Oscillation whose amplitude increases continuously until an attitude is reached from which there is no tendency to return toward the original attitude, the motion becoming a steady divergence.

Performance characteristics (airship).—In general:

Maximum speed at various altitudes.

Maximum altitude attainable with definite weight relations and ballonet volume (if fitted).

Endurance at full and half power.

Static ceiling.

Dynamic lift under specified conditions.

Pitch of propeller:

Effective.—Distance which aircraft advances along its flight path for one revolution of propeller. Its symbol is p_e .

Geometrical.—Distance which an element of a propeller would advance in one revolution if it were moving along a helix of slope equal to its blade angle.

Mean geometrical.—Mean of the geometrical pitches of the several elements. Its symbol is p_g .

Standard.—Geometrical pitch taken at two-thirds of the radius. Also called “nominal pitch.” Its symbol is p_s .

Zero thrust.—Distance which propeller would have to advance in one revolution in order that there might be no thrust. Also called “experimental mean pitch.” Its symbol is p_v .

Zero torque.—Distance which propeller would have to advance in one revolution in order that the torque might be zero. Its symbol is p_a .

Pitch ratio.—Ratio of the pitch (geometrical unless otherwise stated) to the diameter p/D .

Pitch speed.—Product of mean geometrical pitch by number of revolutions of propeller in unit time, that is, the speed aircraft would make if there were no slip.

Propeller area, projected.—Total area in the plane perpendicular to propeller shaft swept by propeller, except portion covered by the boss and that swept by root of the blade. This portion is usually taken as extending 0.2 of maximum radius from axis of the shaft.

- Propeller blade area.**—Area of the blade face, exclusive of the boss and the root, that is, of a portion which is usually taken as extending 0.2 of maximum radius from axis of the shaft.
- Propeller-camber ratio.**—Ratio of maximum thickness of propeller section to its chord.
- Propeller efficiency.**—Ratio of thrust power to power input of propeller. Its symbol is η .
- Propeller, pusher.**—Propeller mounted to rear of engine or propeller shaft. (It is usually behind the wing cell or nacelle.)
- Propeller rake.**—Mean angle which the line joining the centroids of the sections of propeller blade makes with a plane perpendicular to the axis.
- Propeller section.**—Cross section of propeller blade made at any point by a plane parallel to axis of rotation of propeller and tangent at the centroid of the section to an arc drawn with the axis of rotation as its center.
- Propeller thrust.**—Component parallel to propeller axis of the total air force on the propeller. Its symbol is T .
- Propeller torque.**—Moment applied to propeller by engine shaft. Its symbol is Q .
- Race rotation.**—Rotation produced by action of propeller of stream of air passing through or influenced by propeller.
- Reynolds number.**—Name given the fraction $\rho \frac{Vl}{\mu}$ in which—
 ρ = density of the air.
 V = relative velocity of the air.
 l = linear dimension of the body.
 μ = coefficient of viscosity of the fluid.
- Revolutions, maximum.**—Number of revolutions per minute corresponding to maximum horsepower.
- Revolutions, normal.**—Highest number of revolutions per minute that may be maintained for long periods.
- Righting moment (or restoring moment).**—Moment which tends to restore aircraft to its previous attitude after any small rotational displacement.
- Rudder.**—Movable auxiliary airfoil function of which is to impress a yawing moment on aircraft in normal flight. It is usually located at rear of aircraft.
- Skim friction.**—Tangential component of fluid force at point on surface.

- Slip*.—Difference between mean geometrical pitch and effective pitch. Slip may be expressed as a percentage of the mean geometrical pitch or as a linear dimension.
- Slip function*.—Ratio of speed of advance through undisturbed air to the product of propeller diameter by number of revolutions in unit time, that is, $\frac{V}{ND}$. Slip function is the primary factor controlling propeller performance. It is π times ratio of forward speed to tip speed of propeller.
- Slipstream*.—Stream of air driven astern by propeller. (The indraft is sometimes included also.)
- Speed, ground*.—Horizontal component of velocity of aircraft relative to the earth.
- Stability*.—That property of a body which causes it, when disturbed from a condition of equilibrium or steady motion, to develop forces or moments which tend to restore the body to its original condition.
- Automatic*.—Stability dependent upon movable control surfaces automatically operated by mechanical means.
- Directional*.—Stability with reference to rotations about the normal axis, that is, an airship possesses directional stability in its simplest form if a restoring moment comes into action when it is given a small angle of yaw. Owing to symmetry, directional stability is closely associated with lateral stability.
- Inherent*.—Stability of an aircraft due solely to disposition and arrangement of its fixed parts, that is, that property which causes it when disturbed to return to its normal attitude of flight without use of controls or interposition of any mechanical devices.
- Lateral*.—Stability with reference to disturbances involving rolling, yawing, or side slipping, that is, disturbances in which position of the plane of symmetry of the aircraft is affected.
- Longitudinal*.—Stability with reference to disturbances in the plane of symmetry, that is, disturbances involving pitching and variation of longitudinal and normal velocities.
- Static*.—Stability of such a character that, if the airship is displaced slightly from its normal attitude by rotation about an axis through its center of gravity (as may be done in wind tunnel experiments), moments come into play which tend to return the airship toward its original attitude.
- Streamline*.—Path of a small portion of a fluid relative to a solid body with respect to which the fluid is moving. The term is com-

monly used only of such flows as are not eddying, but the distinction should be made clear by the context.

Streamline flow.—Steady flow past a solid body, that is, a flow in which the direction at every point is independent of time.

Streamline form.—Solid body which produces approximately streamline flow.

Surface, control.—Movable airfoil designed to be rotated or otherwise moved by the pilot in order to change attitude of airplane or airship.

Tail group (or tail unit).—Stabilizing and control surfaces at rear end of aircraft, including stabilizer, fin, rudder, and elevator. (Also called "empennage.")

Tail heavy (airship).—Condition in which in normal flight the after end of an airship tends to sink and which requires correction by means of the horizontal controls. In this condition an airship is said to "trim by the stern." It may be due to either aerodynamic or static conditions, or to both.

Thrust, static.—Thrust developed by propeller when rotating at a fixed point.

Tractor propeller.—Propeller mounted on forward end of engine or propeller shaft. (It is usually forward of fuselage or wing nacelle.)

Trailing edge.—Rearmost edge of airfoil or propeller blade.

5. Types of airships.—*a.* Airships are divided into three general classes in accordance with their method of construction. These three classes are—

- (1) Nonrigid.
- (2) Semirigid.
- (3) Rigid.

b. The names describe means by which shape of the envelope is maintained. In the nonrigid, gas in the envelope is kept under sufficient pressure to keep the hull shape by this means alone. In the semirigid a central keel is provided which carries the loading and is itself swung by suspensions from the top of the envelope. Due to its rigidity, the keel assists the internal pressure in maintaining shape of the envelope. In rigid construction a metal structure is provided to maintain shape of the hull. Usually the gas is at atmospheric pressure, although in some cases a slight superpressure is maintained.

c. All types have control and power plant cars and control surfaces.

(1) In small nonrigids cars are usually open and contain power plants as well as altitude and direction controls. Such cars are usually suspended by cables attached to the envelope. In semirigid and rigid construction cars are in contact with the keel which carries their load. Power plant cars are separate from the control car.

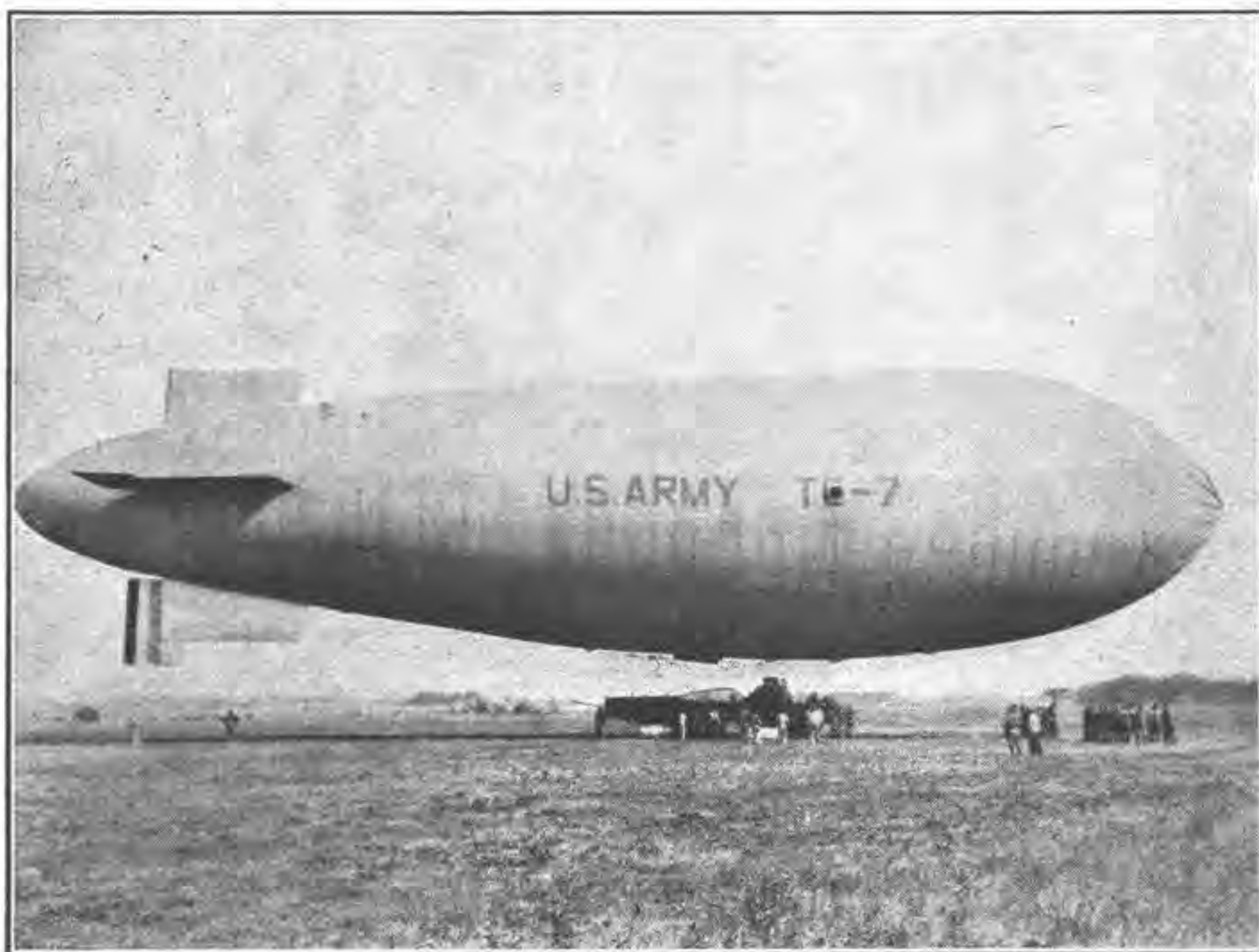

FIGURE 1.—U. S. Army nonrigid TC-7.

(2) Control surfaces on nearly all airships consist of fixed vertical and horizontal surfaces, attached to which are elevators and rudder. On nonrigids and some semirigids these surfaces are attached to the envelope by rigging. On Italian type semirigids and on all rigids control surfaces are supported by metal framework.

d. Figures 1, 2, 3, and 4 depict types of airships, showing general streamlined shape of the hull and arrangement of cars and surfaces.

6. Aerodynamic forces.—Aerodynamic forces may be divided into two classes, those parallel and those normal to the path.

a. The former, or drag forces, retard the flight of the airship and must be overcome by the power plants acting through the thrust of the propellers. Power requirements in their turn affect fuel consumption and limit performance of the airship. Hence a thorough knowledge of resistance and power requirements is essential to intelligent operation of airships.

AIRSHIP AERODYNAMICS

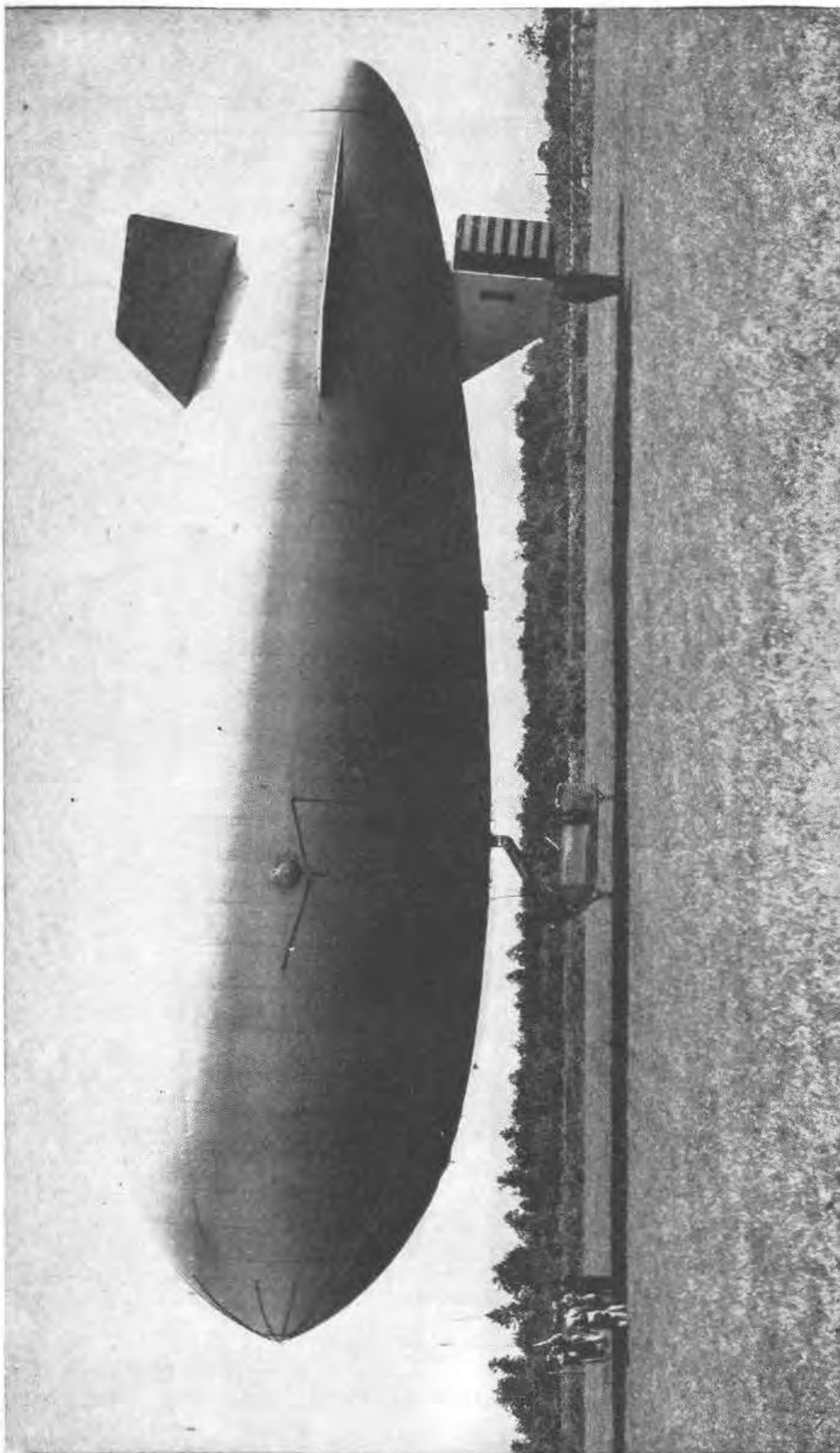

FIGURE 2.—U. S. Army nonrigid motorized observation balloon, U-6.

b. The second class of aerodynamic forces, sometimes called transverse forces, is the result of use of control surfaces or of gusts encountered by the airship. Calculation of the effects of these forces is, as mentioned before, often a matter of more interest to the designer than to the operator, but an understanding of the principles involved

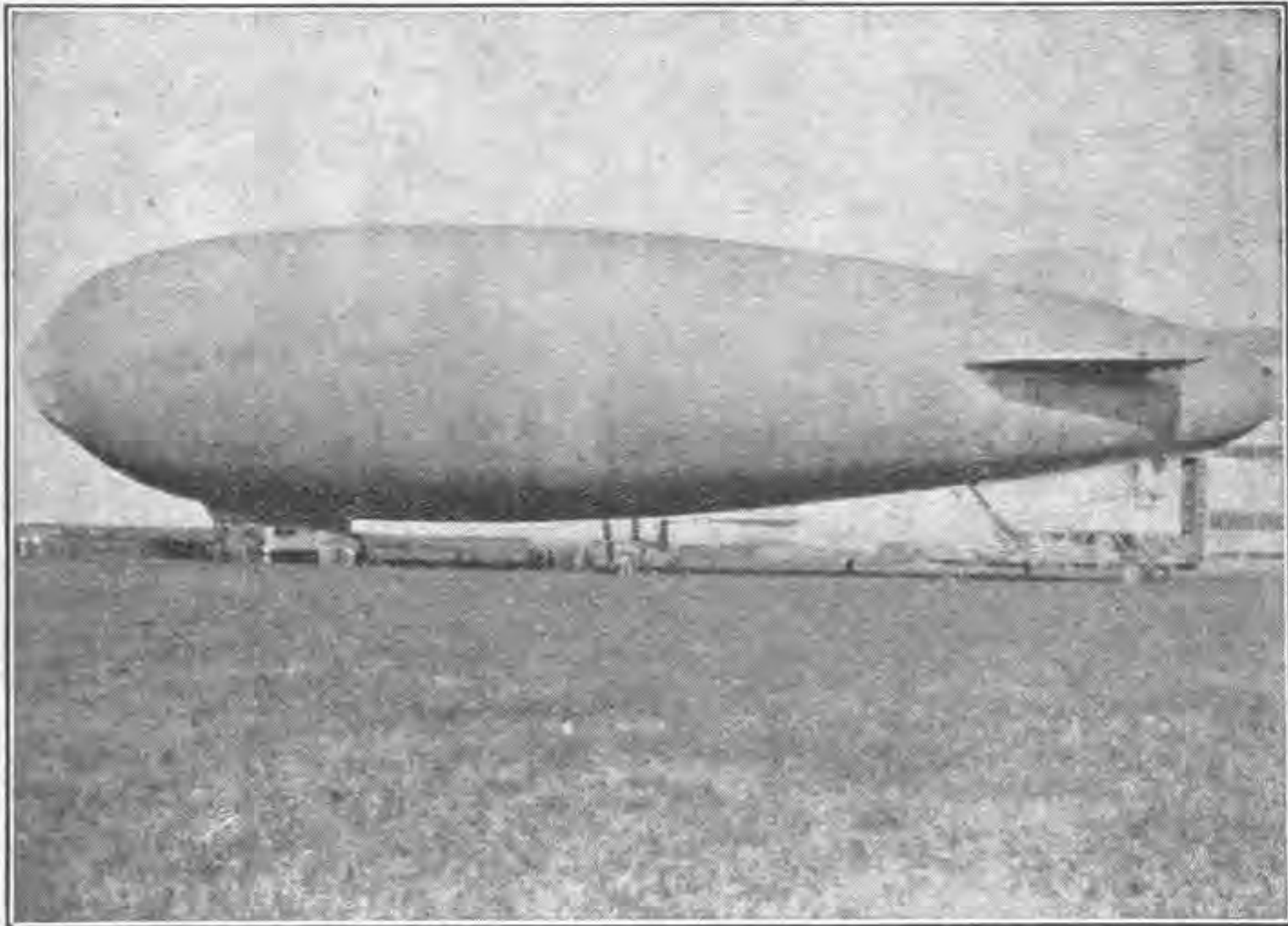

FIGURE 3.—U. S. Army semirigid *RS-1*.

is necessary because it is through these forces that control and stability are effected.

SECTION II

RESISTANCE

	Paragraph
Fluid resistance.....	7
Shape coefficients.....	8
Coefficient of skin friction.....	9
Resistance of streamlined body.....	10
Prismatic coefficient.....	11
Index of form efficiency.....	12
Illustrative resistance problem.....	13
Scale effect.....	14
Resistance of completely rigged airship.....	15
Deceleration test.....	16

7. Fluid resistance.—*a.* Before attempting the study of resistance the student should be familiar with the composition and nature of

the atmosphere, with density and specific gravity calculations, and with the action of gravitational forces. These matters are discussed in TM 1-325.

b. Whenever a solid object moves through a fluid it encounters a resistance to its motion. This resistance may be considered from two points of view.

(1) *Momentum theory.*—(a) By Newton's first law, a body at rest or in motion will remain at rest or continue to travel at constant



FIGURE 4.—U. S. Navy rigid *Los Angeles*.

velocity unless some force is exerted to change its condition. To enable the solid to maintain its motion relative to the fluid, the molecules of the fluid must be deflected to make room for the passage of the solid. So to deflect the fluid or air a force must be applied. In the case of the airship this force is that furnished by the propeller thrust.

(*b*) It can be proved mathematically that if air were incompressible and nonviscous, that is, incapable of offering resistance to shear between the particles, the thrust of air particles opposing the motion of the solid would exactly equal the thrust of the air assisting the motion. Hence there would be no resistance to the motion. However, in the atmosphere this ideal condition does not exist and the resistance is proportional to the total kinetic energy of the deflected particles of air.

(2) *Pressure-difference theory.*—Figure 5 shows the motion of the particles of an air stream passing a flat plate held at right angles to the flow. The air is deflected from its course some distance in front of the plate and has a complex eddying motion in rear of it. In front of the plate the air is under an increased pressure, while behind the plate there is an area of reduced pressure. The drag can be considered as due to the difference between the pressures in front of and behind the plate.

8. Shape coefficients.—*a.* The two systems in common use for expressing air resistance are the engineering and the absolute.

(1) Under the engineering system the formula is—

$$R_p = K_x A V^2$$

where R_p = air resistance due to pressure difference.

A = cross sectional area normal to the air stream in square feet.

V = velocity of motion in miles per hour.

K_x = an empirically determined constant depending on the shape of the solid and the mass density of the air.

In lighter than air practice the letter “ K ,” minus subscript, is used to denote K_x when the mass density of the air is standard (0.00237 pound per cubic foot, which is the value when the pressure is 29.92 inches and the temperature is 60° F.).

(2) The absolute system, adopted by the National Advisory Committee for Aeronautics, uses the formula:

$$R_p = K_D A \rho \frac{v^2}{2}$$

where ρ = mass density of the air.

v = velocity of motion in feet per second.

K_D = an empirical shape coefficient.

$\frac{\rho v^2}{2}$ is the dynamic pressure per unit of area or the velocity head of the air stream. This formula has more definite physical interpretation than the engineering formula from both the momentum and pressure-difference theories. Before studying aerodynamic data, the system which is being used should always be determined.

b. Some of the first practical tests made to determine the effect of shape upon the resistance offered the motion of solids through the air were conducted by Eiffel. Since then studies have been conducted by various investigators until at present the store of information on this subject is quite elaborate. Figures 5 to 15 give the action of the air on various shapes together with the values of K .

AIRSHIP AERODYNAMICS

(1) *Flat plate.*—Figure 5, as described in paragraph 7b (2), shows a flat plate held normal to the air stream. Eiffel demonstrated that the circular disk gives about 5 percent less resistance than the square flat plate. Rectangles have slightly higher values of K than the square plate of the same area, the airflow around the edges of the

$$K = .00328$$

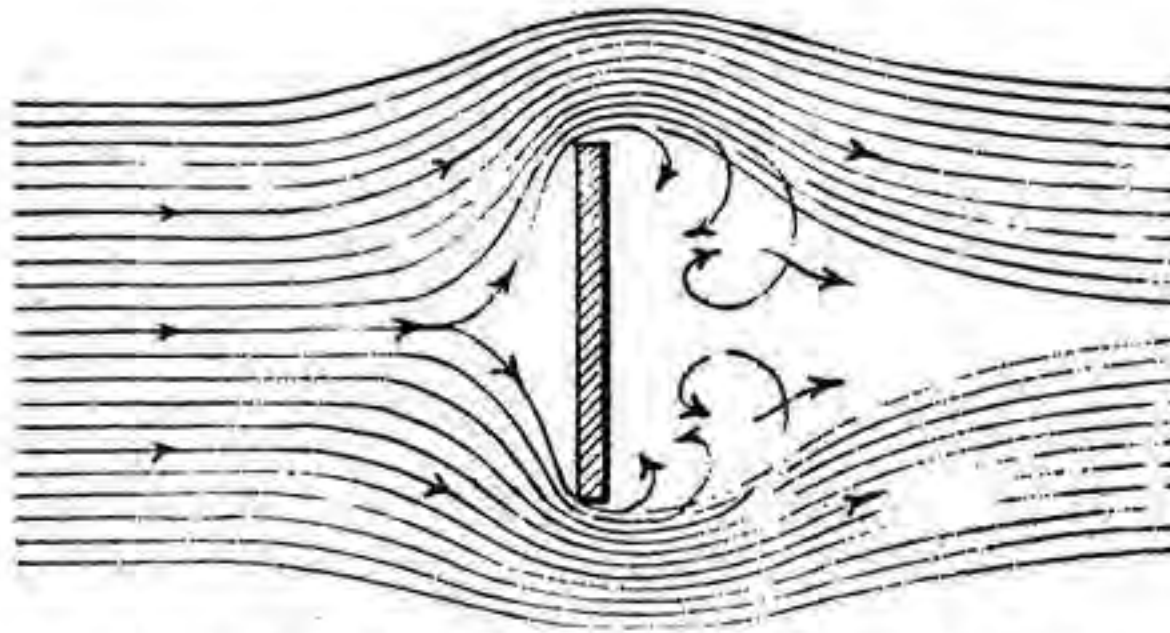

FIGURE 5.—Air stream flowing by a flat plate.

$$K = .00328 \frac{\alpha}{27}$$

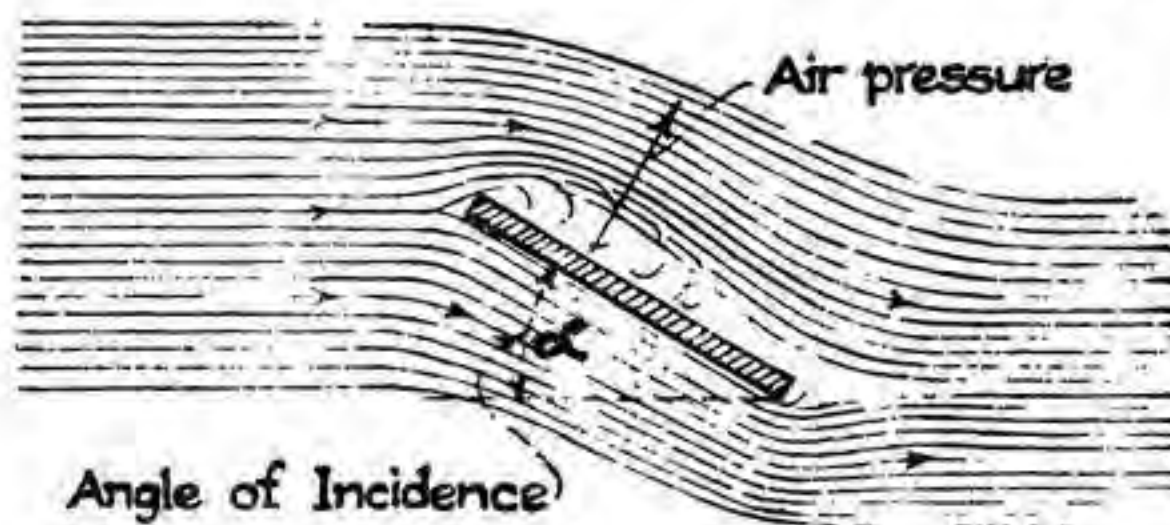

FIGURE 6.—Air stream flowing by an inclined plate.

rectangle being somewhat more restricted than that in the case of the square.

(2) *Flat plate, inclined.*—Figure 6 illustrates the case of the flat plate inclined to the air stream. Eiffel's constants for different angles of incidence are as follows:

Angle of incidence	K
1°	0.00010
5°	0.00059
10°	0.00124
15°	0.00193
20°	0.00265

(3) *Concave hemisphere.*—Experiments have shown that the resistance of a hemisphere with the concave side facing the direction of motion is greater than that of a flat disk of the same exposed

cross section. K for a concave hemisphere is about 0.00389 (see fig. 7).

(4) *Convex hemisphere.*—For a hemisphere with the convex side facing the direction of motion or pointing against the wind the

$$K = .00389$$

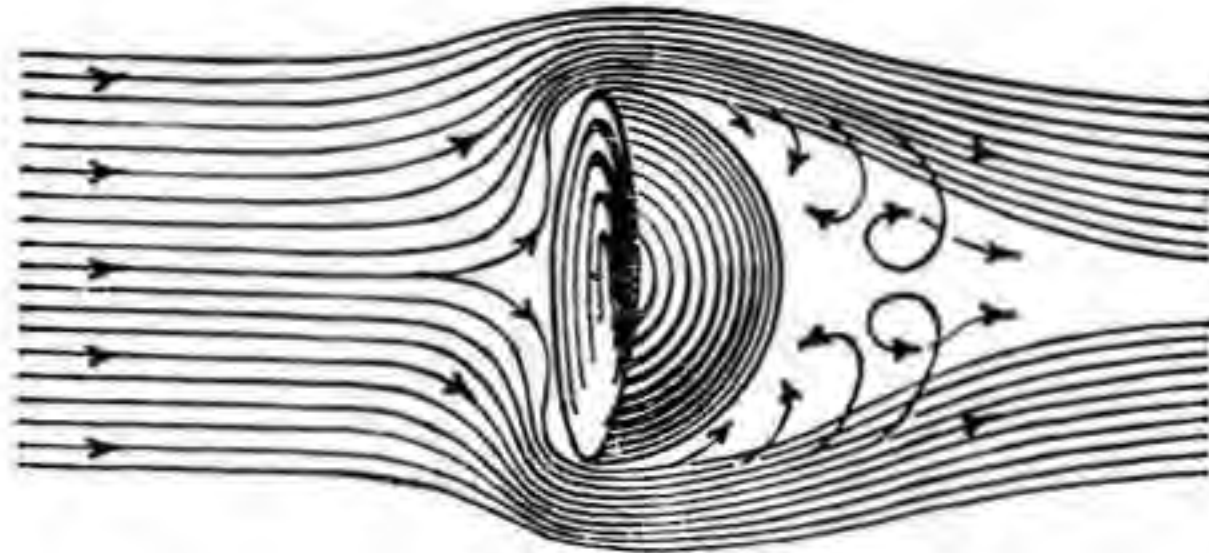

FIGURE 7.—Air stream flowing by a concave hemisphere.

$$K = .00082$$

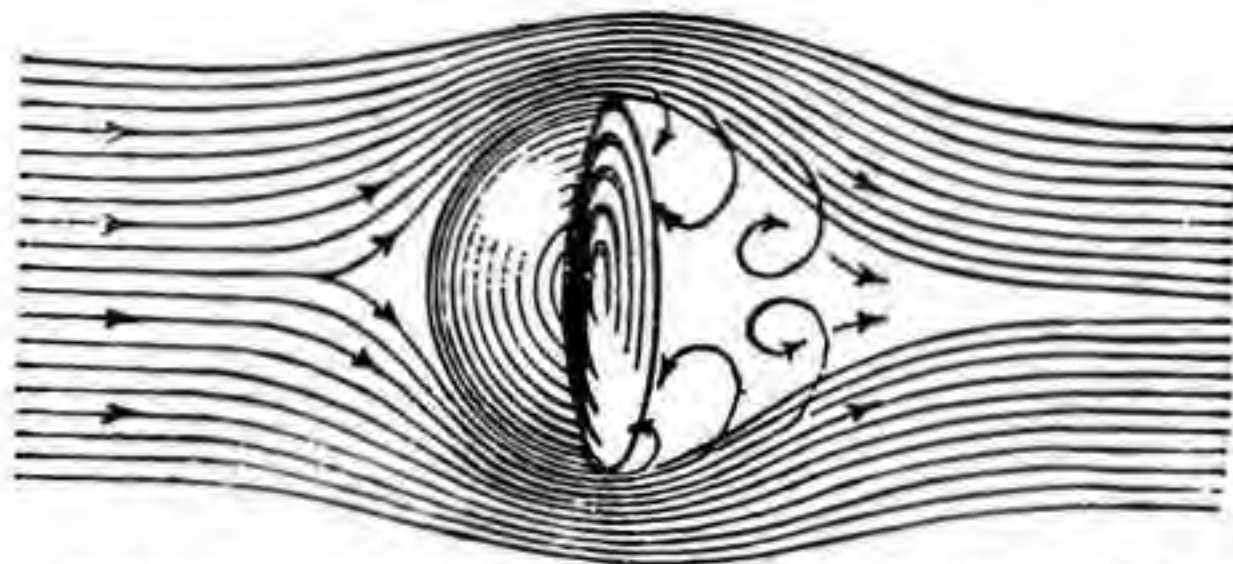

FIGURE 8.—Air stream flowing by a convex hemisphere.

$$K = .0008$$

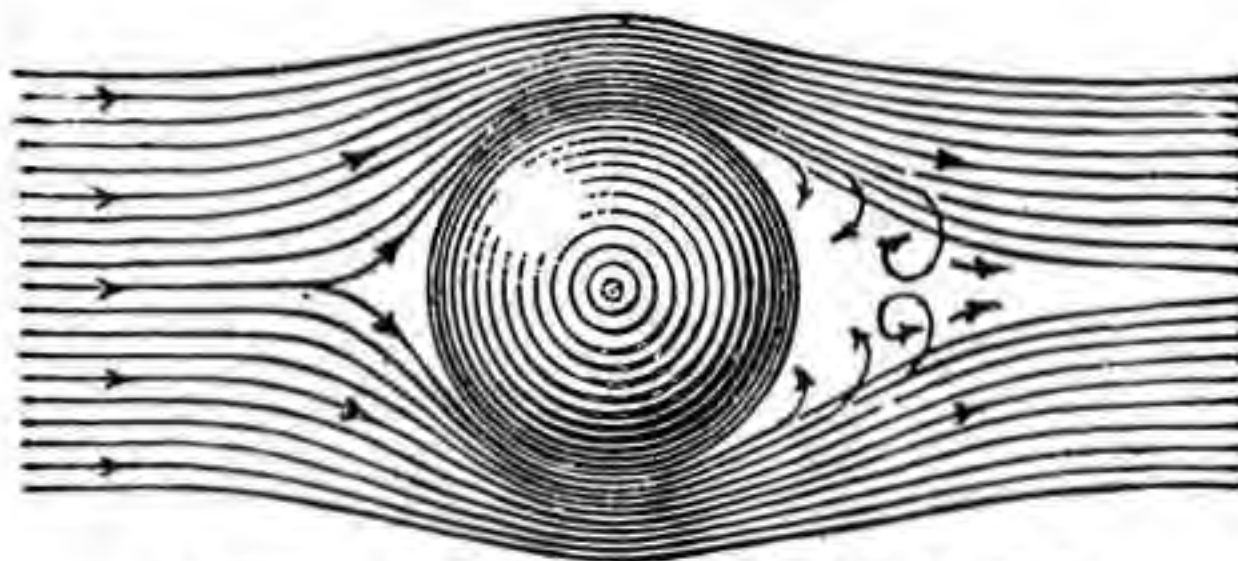

FIGURE 9.—Air stream flowing by a sphere.

resistance is much less than for the concave hemisphere shown in figure 7. The resistance of the convex hemisphere is much less than that of a flat plat of the same cross section or exposed area. The coefficient of resistance is found to be about 0.00082 (see fig. 8).

AIRSHIP AERODYNAMICS

(5) *Sphere*.—The air flow around a sphere (which more closely approaches a streamline form) is shown diagrammatically in figure 9. It will be observed that the spreading out of the lines of flow before reaching the sphere is less marked than for the flat plate in figure 5. The coefficient of resistance of a sphere varies somewhat with the speed,

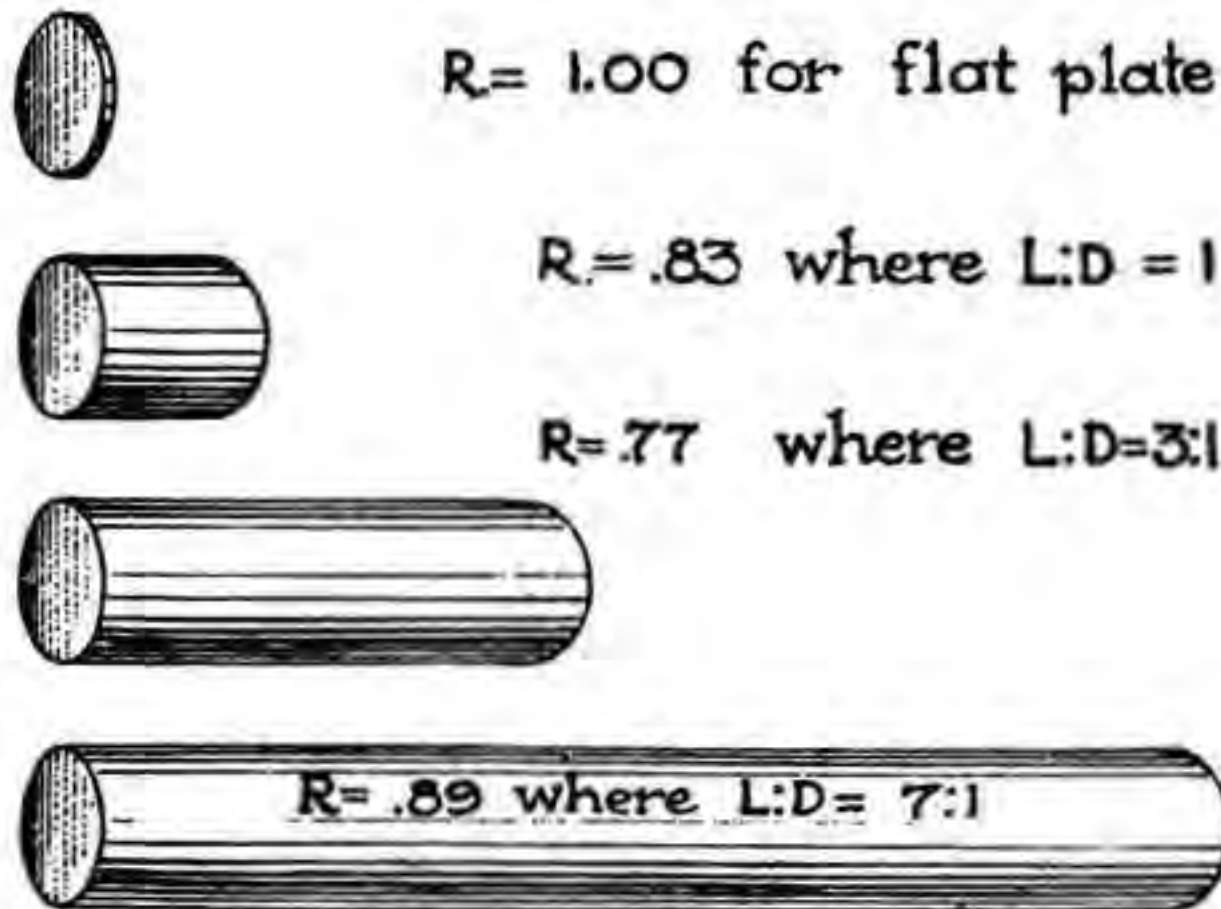

FIGURE 10.—Cylinders.

but for ordinary velocities its value is about 0.008. The sphere is the simplest geometrical form and is the most efficient shape for maximum volume per unit weight but has a greater resistance than the more perfect streamline form (see fig. 9).

(6) *Cylinder (longitudinal axis horizontal)*.—The resistance of such cylinders decreases with length until the fineness ratio is approxi-

$$K = .00123 \text{ for } \frac{L}{D} = .5$$

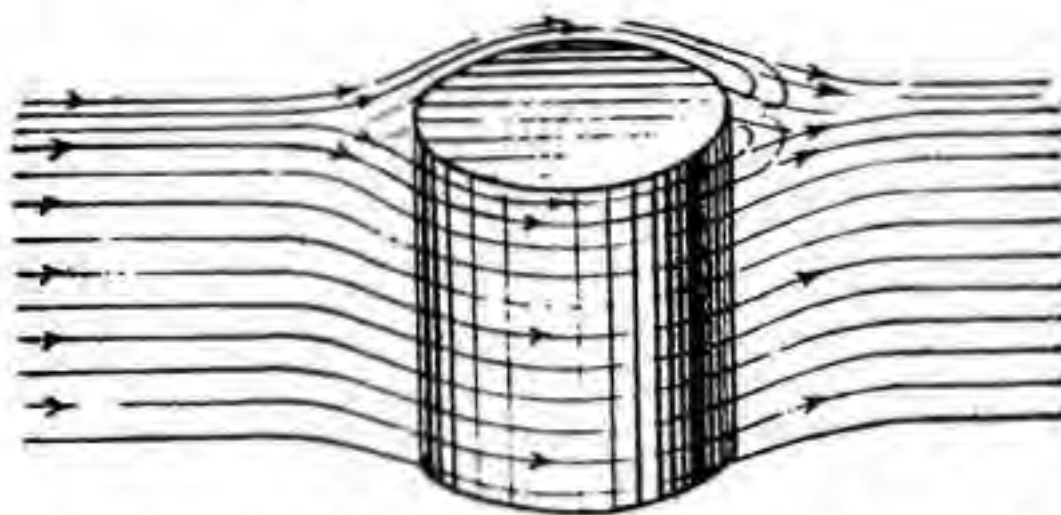

FIGURE 11.—Air stream flowing by a cylinder (axis normal to air flow).

mately 4 to 1, after which it increases. The increase is due to the effect of skin friction which will be discussed later. The relative resistance of cylinders as compared to that of a flat plate of the same cross section is as shown in figure 10. Where the fineness ratio is 4 to 1, $K = 0.00205$.

(7) *Cylinder (vertical).*—When a cylinder of given cross-sectional area is placed with its axis of revolution at right angles to the direction of motion the resistance depends upon the fineness ratio of the cylinder. When the length and diameter of the cylinder are the same the coefficient of resistance is only slightly greater than for a sphere of the same

$$K = .0006 \text{ for } \frac{L}{D} = 4$$

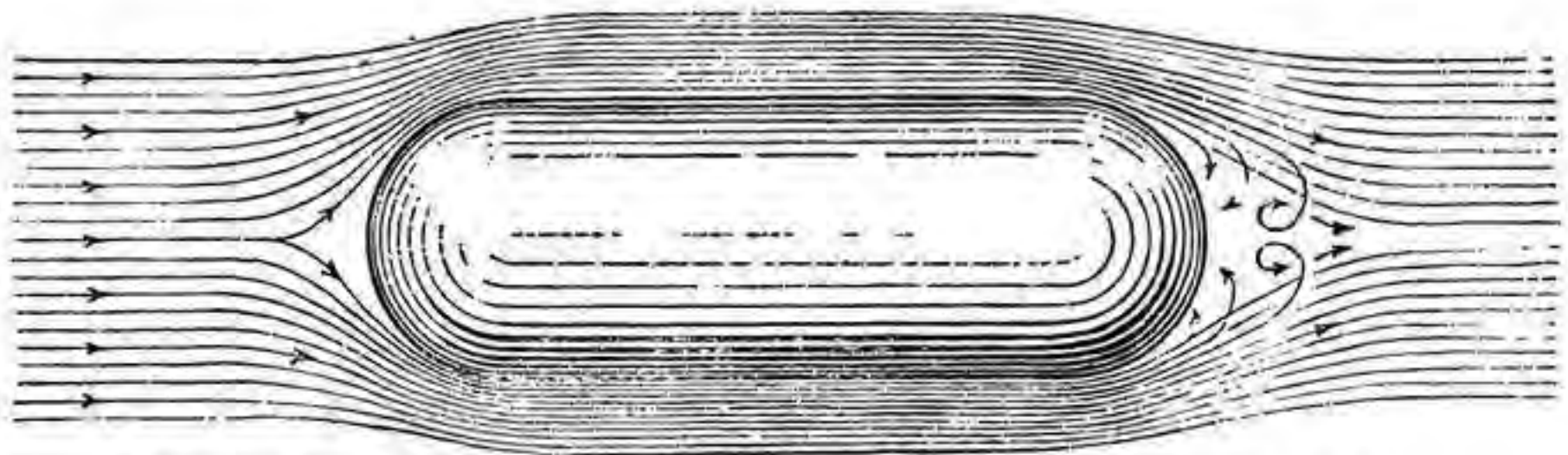

FIGURE 12.—Air stream flowing by a cylinder (hemispherical ends).

cross-sectional area. When the length-diameter ratio is increased to 4 to 1 the coefficient of resistance is approximately doubled, or $K=0.0018$, and if the length-diameter ratio is reduced to one-half (or 0.5/1) the coefficient of resistance is increased 27 percent, or $K=0.00123$ (see fig. 11).

(8) *Cylinder with hemispherical ends.*—It is possible to reduce greatly the resistance of a cylinder by capping the ends with hemi-

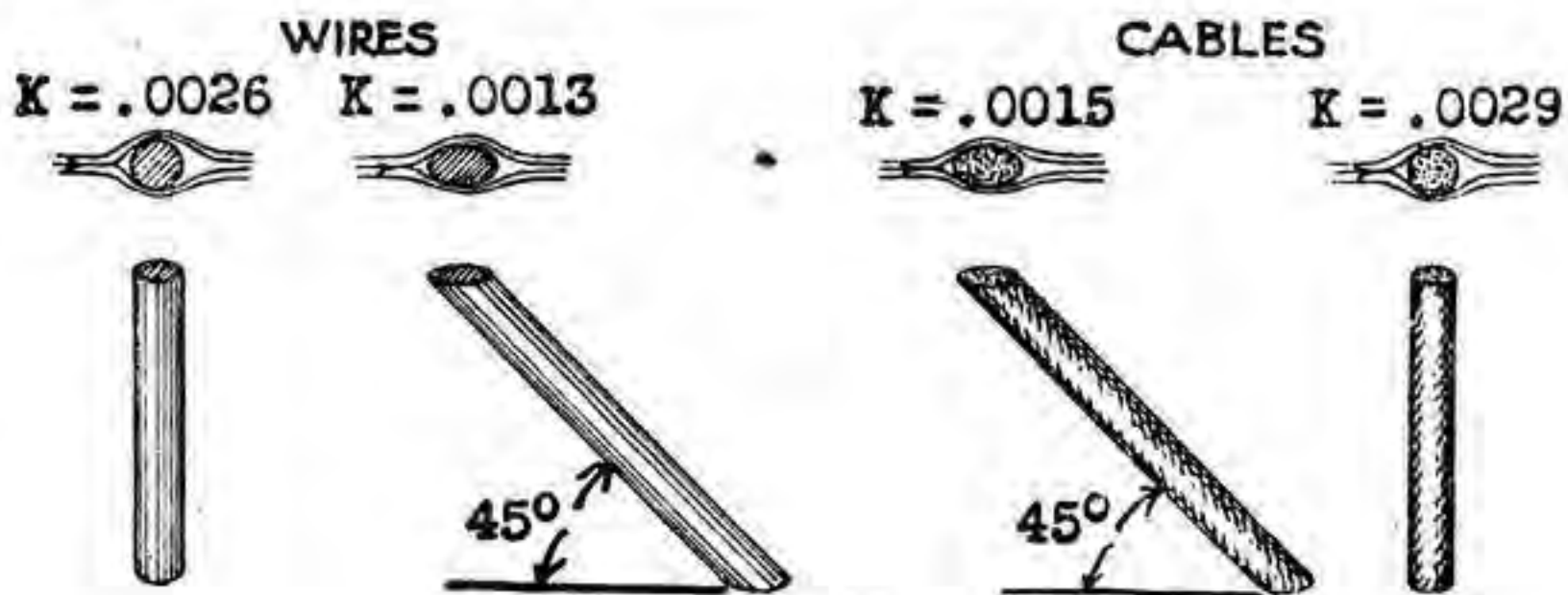

FIGURE 13.

spheres. The resistance is reduced to 20 percent of that of a cylinder with flat ends. The value of K for a cylinder with hemispherical ends and a fineness ratio of 4 is approximately 0.0006 (see fig. 12).

(9) *Wires and cables.*—Wires and cables may be considered as cylinders of very long length. Experiments show that the resistance of wire or stranded cable when placed normal to direction of motion is very nearly equal to the resistance of a flat plate of the same projected area. The gain by the circular form of the wire is counterbalanced by its very

great length. The resistance of a long, narrow object perpendicular to direction of motion is greater than that of a more symmetrical form. The experimentally determined value of the coefficient of resistance is 0.0029 for stranded cables and 0.0026 for smooth wires. K is almost in-

dependent of the diameter for all sizes of wire and cable. Stranded wire or cable has a resistance about 14 percent greater than solid wire.

(a) The above discussion relates only to wires and cables perpendicular to the wind direction or direction of motion. When a wire or cable is inclined to the perpendicular its resistance is very much decreased as the air flows around it in more uniform streamlines or in a more gradual curved path. An inclination of about 30° from the vertical reduces the resistance 20 percent and an inclination of 45° reduces the resistance 50 percent.

(b) When two wires or cables are close together and placed one just behind the other there is a reduction in resistance due to shielding of the second wire by the first. If they are placed very close together their combined resistance is considerably less than the resistance of one wire alone, as the two wires have the effect of an increased fineness ratio. If they are spaced more than $3\frac{1}{2}$ diameters their combined resistance becomes greater than a single wire but is still less than the resistance of the two wires tested separately. This shows that if two wires or cables are close together (within 5 diameters

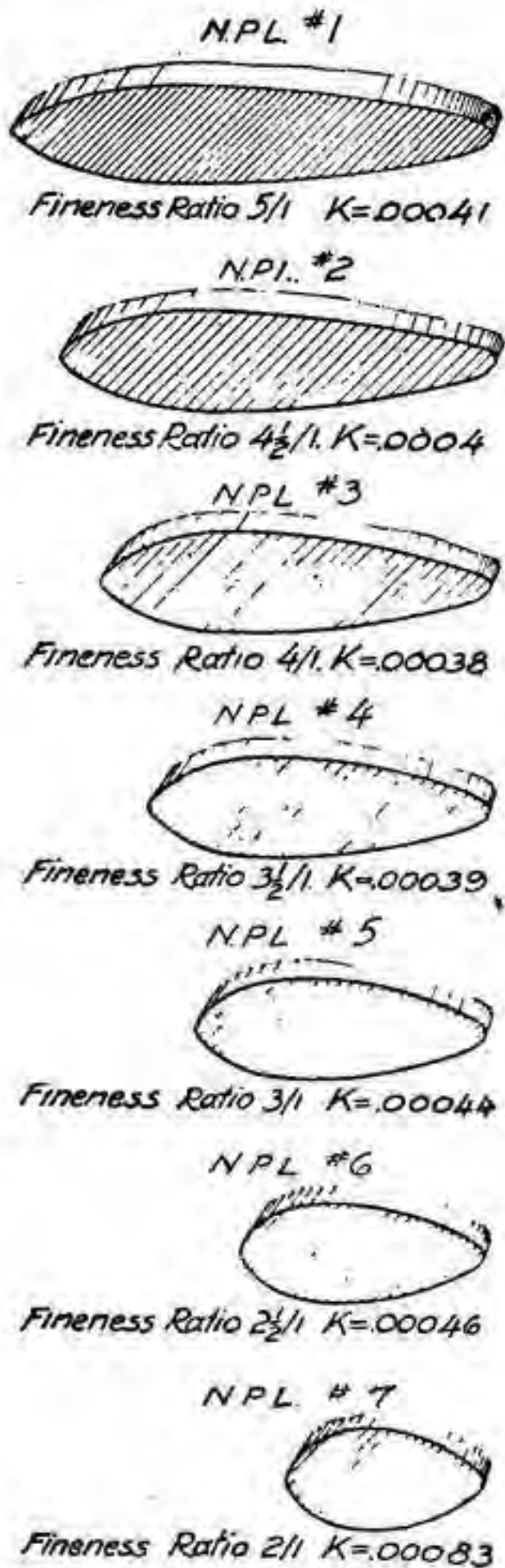

FIGURE 14.—Struts.

of each other) it is very advisable to put a filler block in between them, thus preventing the air from flowing in between them and giving them the advantage of a single member of high fineness ratio. If the two wires are streamlined in this way their combined resistance can be kept down to about 50 percent of the resistance of a single wire until their fineness ratio becomes greater than seven. The high value of the resistance caused by wires and cables immediately suggests reduction of wires and cables to the minimum by means of refinements in design and arrangement.

(10) *Struts of streamline form.*—It is found in practice that the best fineness ratio for struts is 4 to 1. Inclining the strut to the vertical does not have the effect of reducing the resistance for streamline forms, but for blunter shapes (shorter than the true streamline) inclination reduces the resistance considerably. A group of strut sections are shown in figure 14 and the value of K for each shape is shown. It can be seen that the effect of yawing is to increase greatly the resistance by placing the strut sidewise or at a different angle to the air stream.

(11) *Airship cars.*—All cars are built to take advantage of streamline form. This is especially true of the inclosed models for which an average value of K is 0.001. However, there is a wide variance in the shape of airship cars and a corresponding variance in the value of K .

$K = .001$ (average value)

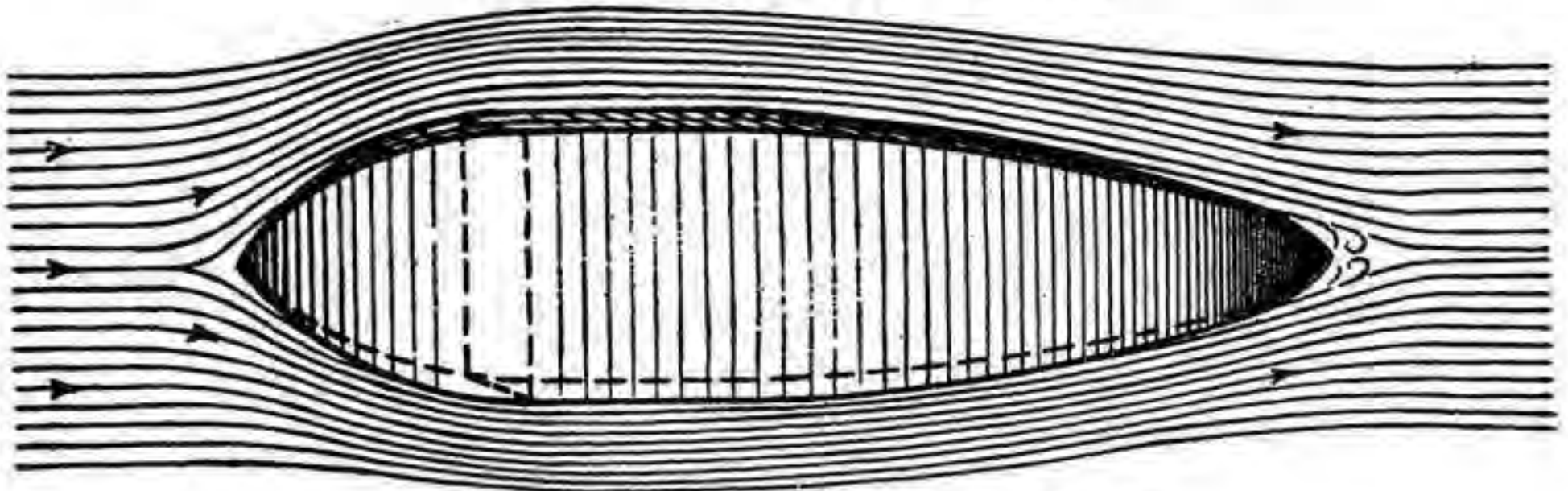

FIGURE 15.—Air stream flowing by airship.

For each different shape a new value of K must be determined by wind tunnel test.

c. The following problem illustrates use of the resistance formula :

(1) *Problem.*—(a) What is resistance of a flat plate 1 foot square placed at right angles to direction of motion when moving at a velocity of 30 miles per hour in air of standard density?

(b) What is resistance at 60 miles per hour?

(2) *Solution.*

(a) $R_p = KAV^2 = 0.00328 \times 1 \times 900 = 2.95$ pounds.

(b) $R_p = KAV^2 = 0.00328 \times 1 \times 3600 = 11.81$ pounds.

This problem illustrates rapidity with which resistance increases with increasing velocity.

d. Based on resistance of a flat disk, the following shapes have the relative resistance shown below :

	<i>Percent</i>
Square plate.....	104.5
Cylinder, horizontal.....	65.5
Sphere.....	25.4
Cylinder, capped ends.....	21.0
Airship model.....	3.0

9. Coefficient of skin friction.—*a.* In the case of a flat plate at right angles to the air stream the resistance is almost entirely due to the pressure difference in front of and behind the plate. This is not however the case with most solids. In general, resistance may be divided into two parts:

- (1) Pressure difference.
- (2) Skin friction.

b. When a solid passes through the air it carries along with it a very thin layer of air, the exterior surface of which forms a plane of air cleavage. The resistance of the air particles to shear on this plane is called skin friction.

c. The value of the skin friction on an airship hull, as determined empirically by Zahm and others, is given by the formula:

$$R_f = 0.0035\rho S^{0.93} v^{1.86}$$

where S is the total surface area. A somewhat more convenient formula is—

$$R_f = 0.00309\rho S v^{1.85}$$

10. Resistance of streamlined body.—*a.* As mentioned before, the total resistance is composed of resistance—

- (1) Caused by pressure difference.
- (2) Due to skin friction.

The pressure-difference resistance is least for a very long and slender form. In fact, the greater the fineness ratio, the less will be the pressure-difference resistance. An increase in fineness ratio, however, leads to an increase in surface area and so to an increase in skin friction. It is necessary therefore to compromise on a moderate fineness ratio, as a very long and slender form would have so high a skin friction as to more than counterbalance the gain by reduction of the pressure-difference resistance. A fineness ratio of 4 to 1 is very good for a small nonrigid, but for large rigids it has been found advisable to increase this ratio to 6 or 7 to 1. Recently an airship had been designed whose hull has a much smaller fineness ratio than the conventional designs. This airship has a capacity of 200,000 cubic feet and a fineness ratio of 2.82, noticeably shorter than any ships recently constructed. A model of this ship was tested in the wind tunnel of the Washington Navy Yard and was found to have the lowest resistance coefficient of any model ever tested there.

b. Since the volume varies as the cube of a linear dimension, while the cross-sectional area and surface area both vary only as the square,

the resistance is proportional to the two-thirds power of the volume. This leads to a more convenient expression for the resistance of airship hulls as follows:

$$R = C_D \rho (\text{volume})^{2/3} v^{1.88}$$

where C_D is called the Prandtl shape coefficient after the eminent authority, Professor Prandtl. Values of C_D for various speeds are given in table I.

c. The offsets for different types of airships are given in table II. A study of the shapes given therein in connection with the Prandtl coefficients will bring out the relative efficiency of the different streamlines.

d. Certain general rules of design developed by experience and test may be summarized as follows:

(1) The best form is one of continuous curvature with radius of curvature constantly increasing toward rear portion.

(2) The shape of extreme rear portion of the hull does not seriously affect the resistance.

(3) The introduction of a cylindrical midsection causes an additional resistance equal to the skin friction on the increased surface area of the hull.

(4) The major diameter should lie between 33 and 40 percent of total length from the bow.

11. Prismatic coefficient.—The ratio of the volume of any hull form to that of the circumscribing cylinder is called the prismatic coefficient, Q_v .

$$Q_v = \frac{\text{Volume}}{\text{Maximum cross-sectional area} \times \text{length}}$$

$$\text{Vol} = Q_v AL$$

The prismatic coefficients for different shapes are given in table I.

TABLE I.—Airship model characteristics and data

Name of model	Length, <i>L</i>	Diameter, <i>D</i>	Surface, <i>S</i>	Area maximum cross-sectional area <i>A</i>	Volume, Vol.	Prandtl shape coefficient, <i>C_D</i>			Finess ratio, $\frac{FR}{L} = \frac{L}{D}$	Distance maximum diameter from nose	Distance <i>CG</i> from nose	Prismatic coefficient, $Q = \frac{\text{Vol.}}{A \times L}$	Index of form efficiency, $H_F = \frac{Q}{C_D}$		
						20 m. p. h.	40 m. p. h.	60 m. p. h.					20 m. p. h.	40 m. p. h.	60 m. p. h.
	<i>Feet</i>	<i>Feet</i>	<i>Sq. ft.</i>	<i>Sq. ft.</i>	<i>Cu. ft.</i>					<i>P. ct. L</i>	<i>P. ct. L</i>				
Navy B (Goodrich)-----	3. 527	0. 6967	5. 800	0. 381	0. 8304	0. 0168	0. 0154	0. 0148	5. 060	37. 80	-----	0. 6176	36. 76	40. 10	41. 73
Navy C-----	2. 919	. 6417	4. 750	. 323	. 6259	. 0159	. 0144	. 0136	4. 620	30. 00	46. 37	. 6562	41. 27	45. 57	48. 25
Navy E-----	4. 125	. 6417	5. 007	. 323	. 6690	. 0168	. 0146	. 0142	4. 870	36. 25	48. 64	. 6621	-----	-----	-----
E. P-----	3. 092	. 6417	4. 597	. 323	. 5890	. 0166	. 0147	. 0138	4. 820	41. 59	43. 92	. 6891	35. 49	40. 08	42. 70
I. E-----	2. 985	. 6417	4. 597	. 323	. 5955	. 0175	. 0155	. 0144	4. 650	38. 18	44. 25	. 6169	35. 25	39. 80	42. 84
Goodyear—4 2-----	3. 190	. 6870	5. 470	. 371	. 7840	. 0162	. 0144	. 0134	4. 640	28. 76	-----	. 6624	40. 89	45. 37	49. 43
Goodyear—1-----	3. 420	. 6660	5. 600	. 348	. 7360	-----	-----	. 0141	5. 130	34. 15	-----	. 6184	-----	-----	-----
Goodyear—2-----	3. 830	. 6350	6. 000	. 317	. 7520	-----	-----	. 0141	6. 020	36. 14	-----	. 6194	-----	-----	-----
Goodyear—3-----	3. 670	. 6150	5. 900	. 297	. 7760	-----	-----	. 0140	5. 970	36. 36	-----	. 7119	-----	-----	-----
Goodyear—4-----	3. 190	. 6870	5. 470	. 371	. 7840	-----	-----	. 0153	4. 640	28. 76	-----	. 6624	-----	-----	-----
Astra-Torres-----	3. 167	. 6914	5. 190	. 309	. 6583	. 0190	. 0159	. 0147	4. 580	33. 80	49. 08	. 6590	34. 68	41. 45	44. 83
Parseval P. I-----	3. 942	. 6417	5. 465	. 323	. 7240	. 0185	. 0174	. 0165	6. 140	38. 75	43. 19	. 5679	30. 70	32. 64	34. 42
Parseval P. II-----	3. 208	. 6417	4. 528	. 323	. 5891	. 0181	. 0170	. 0164	4. 990	38. 90	44. 46	. 5677	31. 36	33. 39	34. 62
Parseval P. III-----	3. 208	. 6417	4. 750	. 323	. 6331	. 0179	. 0169	. 0161	4. 699	47. 33	45. 85	. 6095	34. 05	36. 06	37. 86
Parseval S. S. T-----	5. 625	1. 1330	14. 720	1. 008	3. 4550	. 0174	. 0173	. 0170	4. 960	45. 00	45. 83	. 6090	35. 00	35. 23	35. 82
Pony Blimp AA-----	1. 992	. 5833	2. 760	. 267	. 3196	. 0205	. 0254	. 0277	3. 410	42. 50	46. 00	. 6003	29. 28	23. 63	21. 67
UB—FC-----	4. 9383	1. 0591	12. 9584	. 8810	2. 8603	. 0321	. 0223	. 0219	4. 663	-----	-----	. 65746	-----	-----	-----
UB—2-----	4. 4894	1. 1638	12. 2240	1. 0630	2. 9201	. 0205	. 0189	. 0192	3. 823	-----	-----	. 61145	-----	-----	-----
<i>C class cylindrical midships</i>															
¼ diameter-----	3. 109	. 6417	5. 073	. 323	. 6777	. 0154	. 0140	. 0132	4. 850	-----	-----	. 6749	43. 82	48. 21	51. 13
½ diameter-----	3. 270	. 6417	5. 398	. 323	. 7297	. 0153	. 0141	. 0135	5. 100	-----	-----	. 6909	45. 16	49. 00	51. 18
1 diameter-----	3. 590	. 6417	6. 043	. 323	. 8330	. 0164	. 0146	. 0136	5. 570	-----	-----	. 7184	43. 80	49. 21	52. 82
2 diameter-----	4. 232	. 6417	7. 337	. 323	1. 0404	. 0175	. 0150	. 0136	6. 600	-----	-----	. 7611	43. 49	50. 74	55. 96
3 diameter-----	4. 872	. 6417	8. 627	. 323	1. 2471	. 0173	. 0156	. 0148	7. 590	-----	-----	. 7925	45. 81	50. 80	53. 55
4 diameter-----	5. 515	. 6417	9. 922	. 323	1. 4548	. 0175	. 0157	. 0146	8. 590	-----	-----	. 8167	46. 67	52. 02	55. 94
5 diameter-----	6. 158	. 6417	11. 218	. 323	1. 6625	. 0164	. 0154	. 0148	9. 602	-----	-----	. 8358	50. 96	54. 27	56. 47

TABLE I.—Airship model characteristics and data—Continued

Name of model	Length, <i>L</i>	Diameter, <i>D</i>	Surface, <i>S</i>	Area maximum cross-sectional area <i>A</i>	Volume, Vol.	Prandtl shape coefficient <i>C_D</i>			Finess ratio, $\frac{FR}{L} = \frac{L}{D}$	Distance maximum diameter from nose	Distance <i>CG</i> from nose	Prismatic coefficient, $Q = \frac{\text{Vol.}}{A-L}$	Index of form efficiency $H_f = \frac{Q}{C_D}$		
						20 m. p. h.	40 m. p. h.	60 m. p. h.					20 m. p. h.	40 m. p. h.	60 m. p. h.
<i>Elliptical series (British)</i>															
	<i>Feet</i>	<i>Feet</i>	<i>Sq. ft.</i>	<i>Sq. ft.</i>	<i>Cu. ft.</i>					<i>P. ct. L</i>	<i>P. ct. L</i>				
E 1	2. 371	0. 3906		0. 120	0. 1658	0. 0132	0. 0135		6. 070	33. 19		0. 5835	44. 20	43. 22	
E 2	1. 743	. 3910		. 120	. 1261	. 0138	. 0128		4. 460	33. 86		. 6024	43. 65	47. 06	
E 3	1. 568	. 3920		. 121	. 1112	. 0147	. 0120		4. 000	34. 19		. 5876	40. 00	45. 55	
E 4	1. 384	. 3923		. 121	. 0972	. 0167	. 0139		3. 500	35. 18		. 5810	34. 79	41. 80	
E 5	1. 178	. 3929		. 121	. 0826	. 0184	. 0147		3. 000	33. 43		. 5786	31. 45	39. 36	
<i>Parabolic series (British)</i>															
P 1	1. 594	. 3900		. 120	. 0970	. 0168	. 0137		4. 090	49. 39		. 5094	30. 32	37. 18	
P 2	1. 598	. 3903		. 120	. 1000	. 0169	. 0176		4. 070	32. 06		. 5265	31. 15	30. 00	
P 3	1. 173	. 3867		. 117	. 0729	. 0226	. 0173		3. 830	50. 35		. 5293	23. 42	30. 60	
P 4	1. 217	. 3870		. 118	. 0714	. 0215	. 0193		3. 140	35. 05		. 4989	23. 20	25. 85	

TABLE II.—Offsets of various streamline forms, United States models

Navy B (Goodrich)		Navy C		Navy F		E. P.		Parseval P. I		Parseval P. II		Parseval P. III		S. S. T.		Pony blimp AA	
Distance from nose	Diameter	Distance from nose	Diameter	Distance from nose	Diameter	Distance from nose	Diameter	Distance from nose	Diameter	Distance from nose	Diameter	Distance from nose	Diameter	Distance from nose	Diameter	Distance from nose	Diameter
Pct. L.	Pct. D.	Pct. L.	Pct. D.	Pct. L.	Pct. D.	Pct. L.	Pct. D.	Pct. L.	Pct. D.	Pct. L.	Pct. D.	Pct. L.	Pct. D.	Pct. L.	Pct. D.	Pct. L.	Pct. D.
2.36	24.16	2.81	32.47	1.23	23.12	0.13	24.88	1.25	27.37	1.25	27.27	1.25	21.56	1.24	21.41	2.09	20.58
4.73	41.27	5.62	55.06	2.45	35.06	2.59	34.60	2.50	37.92	2.50	37.92	2.50	32.99	2.51	32.98	4.19	33.49
7.09	55.14	8.43	69.61	3.68	43.90	5.19	48.44	5.00	51.95	5.00	51.95	5.00	47.79	4.99	47.83	8.38	54.65
9.45	65.27	11.24	79.22	4.91	50.61	10.37	66.10	10.00	71.17	10.00	71.17	10.00	66.23	9.99	66.07	12.57	67.71
11.81	75.36	16.86	91.17	7.36	62.73	15.56	78.12	14.99	83.38	15.00	83.36	15.00	78.70	14.98	78.89	16.75	77.50
14.18	81.94	22.48	97.40	9.81	72.08	20.75	86.66	19.98	91.17	20.00	91.17	20.00	88.05	19.97	88.07	20.94	84.60
18.90	90.31	28.11	100.00	12.26	78.57	25.94	92.73	24.98	96.10	25.00	96.10	25.00	94.03	24.97	94.04	25.13	89.99
23.63	94.98	33.73	100.00	14.71	84.93	31.12	96.75	29.98	98.96	30.00	98.96	30.00	97.40	29.96	97.32	29.32	94.18
28.35	98.09	42.16	98.18	19.62	93.51	36.31	99.40	34.97	100.00	35.00	100.00	35.00	99.22	34.97	99.11	33.51	97.23
33.09	99.64	50.59	94.29	24.54	98.05	41.50	100.00	39.96	99.48	40.00	99.48	40.00	100.00	39.98	99.80	37.70	99.01
37.82	100.00	59.02	88.83	29.45	99.61	48.81	98.44	44.96	98.18	45.00	98.18	45.00	100.00	44.99	100.00	41.88	100.00
47.25	98.44	67.45	81.56	34.35	100.00	56.12	93.77	49.96	94.81	50.00	94.81	50.00	98.06	50.00	98.75	46.07	99.43
56.70	93.06	75.89	71.69	39.27	99.74	63.43	86.23	54.96	89.87	55.00	89.87	55.00	95.86	54.99	95.87	50.26	98.08
66.15	83.25	84.32	59.48	44.17	98.96	70.74	75.32	59.96	83.90	60.00	83.90	60.00	91.69	59.97	91.75	54.45	95.88
70.88	76.91	89.94	48.57	49.07	97.53	78.05	60.52	64.95	76.36	65.00	76.36	65.00	85.97	64.96	86.24	58.64	93.47
75.60	69.38	92.75	41.56	53.98	95.15	85.36	44.16	69.95	67.53	70.00	67.53	70.00	78.96	69.94	79.14	62.83	89.64
80.33	61.00	95.56	31.95	58.78	62.34	92.68	23.90	74.94	57.66	75.00	57.66	75.00	70.91	74.93	70.34	67.02	84.81
85.05	51.44	98.37	18.96	63.69	88.31	100.00	.0	79.94	47.01	80.00	47.01	80.00	59.74	79.91	59.76	71.20	78.42
89.78	39.35	100.00	.0	68.69	83.25	-----	-----	84.93	35.84	85.00	35.84	85.00	47.27	84.89	47.39	75.40	71.04
92.14	31.94	-----	-----	73.60	77.27	-----	-----	89.92	24.16	90.00	24.16	90.00	23.25	89.87	32.99	79.58	63.52
94.50	23.44	-----	-----	78.51	70.26	-----	-----	91.92	12.21	95.00	12.21	95.00	17.14	94.86	10.83	83.76	54.65
96.86	14.00	-----	-----	83.41	62.38	-----	-----	100.00	.0	100.00	.0	100.00	.0	100.00	.0	87.96	45.78
98.14	8.97	-----	-----	88.32	52.47	-----	-----	-----	-----	-----	-----	-----	-----	-----	-----	92.14	35.49
100.00	.0	-----	-----	93.22	40.52	-----	-----	-----	-----	-----	-----	-----	-----	-----	-----	96.34	22.21
-----	-----	-----	-----	94.45	36.75	-----	-----	-----	-----	-----	-----	-----	-----	-----	-----	100.00	.0
-----	-----	-----	-----	95.68	33.12	-----	-----	-----	-----	-----	-----	-----	-----	-----	-----	-----	-----
-----	-----	-----	-----	96.91	28.31	-----	-----	-----	-----	-----	-----	-----	-----	-----	-----	-----	-----
-----	-----	-----	-----	98.13	22.47	-----	-----	-----	-----	-----	-----	-----	-----	-----	-----	-----	-----
-----	-----	-----	-----	99.36	12.26	-----	-----	-----	-----	-----	-----	-----	-----	-----	-----	-----	-----
-----	-----	-----	-----	100.00	.0	-----	-----	-----	-----	-----	-----	-----	-----	-----	-----	-----	-----

27

AIRSHIP AERODYNAMICS

T.M. 1-320
11

12. Index of form efficiency.—In general, in design it is desired to get the greatest volume from the least surface area as this reduces weight and diffusion. Fortunately, good streamlined shapes usually have high prismatic coefficients, but of course some shapes are more efficient in this regard than others. In studying relative efficiency of shapes, both the resistance coefficients and the prismatic coefficients must be considered. The ratio of the latter to the former is called the index of form efficiency, H_f ,

$$H_f = \frac{Q_v}{C_D}$$

13. Illustrative resistance problem.—*a. Problem.*—Given an airship whose hull has a length of 200 feet and a major diameter of 43.5 feet with the hull offsets those of the C type airship envelope.

- (1) What is total volume of envelope?
- (2) What is hull resistance at 60 miles per hour in standard atmosphere?

b. Solution.

$$(1) \text{ Vol} = Q_v AL$$

From Table I, Q_v is 0.6562.

$$A = \frac{\pi d^2}{4} = \frac{3.1416}{4} (43.5)^2 = 1,485 \text{ square feet.}$$

Hence $\text{Vol} = 0.6562 \times 1,485 \times 200 = 195,000$ cubic feet.

$$(2) R = C_D \rho (\text{vol})^{2/3v^{1.86}}$$

$$60 \text{ MPH} = 60 \times \frac{22}{15} = 88 \text{ feet per second.}$$

C_D from Table I = 0.0136 at 60 MPH

$$R = 0.0136 \times 0.00237 \times (195,000)^{2/3} \times 88^{1.86}$$

$$R = 455 \text{ pounds.}$$

14. Scale effect.—*a.* One great reason why so much difficulty is encountered in determining prior to construction the resistance of the completed hull lies in the fact that the resistance of the model cannot be multiplied by the ratio of the linear dimensions of the model and the completed hull to determine the resistance of the latter. The discrepancy between the calculated resistance and the actual resistance of the full-sized airship is attributed to scale effect. Often errors in calculation due to faulty data or bad theories are so explained away by those responsible for the mistakes. There are several reasons however, why, even with proper data and theory discrepancies will exist between calculated and actual resistance.

b. The theory of dimensions shows that the coefficients of resistance vary directly as $\frac{vL}{\nu}$, where

v = velocity in feet per second.

L = some convenient linear dimension of the body such as the diameter in the case of a cylinder.

ν = kinematic viscosity coefficient of the fluid.

c. ν , the kinematic viscosity coefficient, is defined as the ratio between the absolute viscosity coefficient and the atmospheric mass density. Hence—

$\nu = \frac{\nu}{\rho}$, where ν is the absolute viscosity coefficient of the air and is a constant.

d. $\frac{vL}{\nu}$, called the Reynolds number after Professor Reynolds, depends on three variable quantities, ρ , v , and L . To predict full-scale performance from the model tests, allowance must be made for the fact that the L in the full-sized airship is very different from the L in the model, and consequently the coefficient of resistance will be different.

e. To overcome the effect of this difference a wind tunnel has been built at Langley Field in which ρ may be sufficiently increased to make the product ρL for the model equal that of the full-sized small nonrigid airship, thus eliminating scale effect.

15. Resistance of completely rigged airship.—a. There are very little data available showing the relative resistance of the various parts combining to produce the total resistance of a completely rigged airship due to the difficulty in obtaining dynamic similarity between the model tested and the full-scale airship.

b. Total resistance of airships may be subdivided approximately as follows for—

	<i>Percent</i>
(1) Large nonrigids with closed cars:	
(a) Envelope.....	45
(b) Surfaces.....	20
(c) Rigging and suspension cables.....	15
(d) Cars.....	15
(e) Accessories.....	5
(2) Small nonrigids with open cars:	
(a) Envelope.....	35
(b) Surfaces.....	25
(c) Rigging and cables.....	20
(d) Cars.....	15
(e) Accessories.....	5

	<i>Percent</i>
(3) Semirigids:	
(a) Envelope-----	53
(b) Surfaces-----	20
(c) Rigging-----	7
(d) Cars-----	13
(e) Accessories-----	7
(4) Large rigids:	
(a) Hull-----	60
(b) Surfaces-----	15
(c) Cars and suspensions-----	20
(d) Miscellaneous rigging and accessories-----	5

16. Deceleration test.—*a.* Tests are made frequently on full-sized airships to determine actual resistance of the airship at various speeds. In these tests the airship is brought to a certain velocity and then the motors are idled, the velocity being recorded against time as the airship decelerates.

b. The general theory is that the resistance, or force causing deceleration, is given by the equation :

$$R = M_v \alpha, \text{ where}$$

$$\alpha = (\text{deceleration in feet per second})^2.$$

$$M_v = \text{the virtual mass of the ship.}$$

The virtual mass of an airship is the mass of airship and contents plus the mass of air which is carried along with it. This latter is computed by the Munk formula :

$$\Delta M_v = \frac{\rho \pi r^3}{3}, \text{ where } r \text{ is the radius of largest cross section.}$$

c. Observing velocity at end of each second gives the rate of change of velocity, or deceleration, for each second and by interpolation for each air speed. Actually formulas are employed which involve calculus and are beyond the scope of this manual.

d. These deceleration tests are quite valuable as a check against the resistance formulas developed in this section. They are however often complicated by poor instruments or faulty observation, rendering it difficult to place a proper value on results so obtained. For the present more confidence is to be placed on the resistance formulas and the power requirement formulas which will be developed in the next section.

AIRSHIP AERODYNAMICS

SECTION III
POWER REQUIREMENTS

	Paragraph
Power required to overcome airship resistance.....	17
Results of various speed trials.....	18
Burgess' formula for horsepower.....	19
Speed developed by given horsepower.....	20
Summary.....	21

17. Power required to overcome airship resistance.—*a.* To maintain uniform velocity in flight, resistance of the airship must be overcome by thrust of the propellers. The work done by the propellers equals the product of the resistance times the distance through which the airship moves.

b. The unit of work in the English system is the foot-pound, or the quantity of work performed by 1-pound force acting through a distance of 1 foot. Hence work done in propelling the airship in foot-pounds equals resistance in pounds times air distance traveled by the airship.

c. Power is defined as the rate of doing work, 1 horsepower equaling 550 foot-pounds per second. Therefore the power utilized to overcome hull resistance must equal resistance multiplied by velocity in feet per second divided by 550.

d. The resistance is given by the equation (see sec. II):

$$R = C_D \rho (\text{vol})^{2/3} v^{1.86}$$

Then the horsepower required to overcome this resistance is given by the formula:

$$H. P. = \frac{C_D \rho (\text{vol})^{2/3} v^{2.86}}{550}$$

e. Problem and solution—(1) Problem.—What horsepower will be required to drive an airship of 195,000-cubic-foot capacity at 60 miles per hour (88 feet per second) in atmosphere of standard density? The envelope shape coefficient is 0.0136. The propeller efficiency, E , is 60 percent. The envelope resistance, F , is 40 percent of the total resistance of the airship.

(2) *Solution.*—The horsepower necessary to overcome hull resistance is given by—

$$\begin{aligned} H. P. &= \frac{C_D \rho (\text{vol})^{2/3} v^{2.86}}{550} \\ &= \frac{(0.0136 \times 0.00237 \times 3376.4 \times 359000)}{550} \\ &= 71.1 \text{ horsepower.} \end{aligned}$$

Since hull resistance is but 40 percent of total, the horsepower to overcome total resistance—

$$=71.1\left(\frac{1}{0.40}\right)$$

Since propeller efficiency is 60 percent—

$$\begin{aligned}\text{Total horsepower required} &= (71.1)\left(\frac{1}{0.40 \times 0.60}\right) \\ &= 296 \text{ horsepower.}\end{aligned}$$

f. As illustrated in the problem in *d* above, the following is a convenient formula for the horsepower required when the percentage of resistance due to the hull and the propeller efficiency are known.

$$H. P. = \frac{C_D \rho (\text{vol})^{2/3} v^{2.86}}{550 \times E \times F}$$

g. A commoner method of determining the horsepower requirements is to determine a shape coefficient by wind tunnel test of the completely rigged model. In this case the body in question is not as perfect a streamlined shape as the hull itself so the resistance varies more nearly as the square of the velocity. Then the horsepower required becomes—

$$H. P. = \frac{C'_D \rho (\text{vol})^{2/3} v^3}{550 E}$$

where C'_D is the shape coefficient of the model.

(1) *Problem.*—What horsepower will be required to drive an airship of 195,000-cubic-foot capacity at 60 miles per hour (88 feet per second) when the atmospheric density is standard, the coefficient of resistance C'_D of the completely rigged ship is 0.0165, and the propeller installation efficiency is 60 percent?

(2) *Solution.*

$$\begin{aligned}H. P. &= \frac{C'_D \rho (\text{vol})^{2/3} v^3}{550 E} \\ &= \frac{0.0165 \times 0.00237 \times 195000^{2/3} 88^3}{550 \times 0.60} \\ &= 275 \text{ horsepower, approximately.}\end{aligned}$$

18. Results of various speed trials.—*a.* The following data were obtained by progressive speed trials made on the United States Navy C class nonrigid airship of 180,000-cubic-foot capacity:

AIRSHIP AERODYNAMICS

V in foot-seconds	R. P. M.	B. H. P.	E'	R-pounds			C' _D
				Total	Hull	Appendages	
66.6	1,100	109	60	540	334	206	0.020
73.3	1,200	143	60	643	394	249	.019
80.1	1,300	183	60	754	457	297	.019
87.7	1,400	231	60	875	517	358	.018

The value C'_D is the corrected coefficient of resistance, but its accuracy is somewhat uncertain, also the proportions of hull resistance appear high. The value of C'_D obtained from the wind tunnel test was 0.027. The proportional value of the appendages or parasite resistance was computed from the wind tunnel data.

b. The following data were obtained from deceleration tests of German rigid airships:

Name	Cubic feet	D	L	Number of engines	Maximum velocity	B. H. P.	Proportional efficiency	C' _D
		<i>Feet</i>	<i>Feet</i>		<i>Foot-seconds</i>			
LZ 10	706,000	45.9	460	3	62.4	450	67	0.107
L 33	2,140,000	78.3	645	6	92.5	1,440	49	.039
L 36	2,140,000	78.3	645	6	92.5	1,440	62	.045
L 43	2,140,000	78.3	645	5	88.9	1,200	56	.047
L 44	2,140,000	78.3	645	5	94.0	1,200	56	.031
L 46	2,140,000	78.3	645	5	95.5	1,200	58	.031
L 57	2,640,000	78.3	745	5	94.8	1,200	69	.034
L 59	2,640,000	78.3	745	5	94.6	1,200	66	.038
L 70	2,400,000	78.3	694	7	113.5	2,000	65	.031

19. Burgess formula for horsepower.—a. A very handy formula for determining the horsepower required to drive an airship of any given volume and speed is furnished by the National Advisory Committee for Aeronautics Report No. 194, as follows:

$$H. P. = \frac{v^3 \rho (\text{vol})^{2/3}}{C_p}$$

where C_p is a constant which can be taken from the compilation below:

Nonrigid airships

50,000 to 200,000 cubic feet.....	$C_p=20,000$
200,000 to 300,000 cubic feet.....	$C_p=21,000$
300,000 to 400,000 cubic feet.....	$C_p=22,000$

Rigid airships

1,000,000 to 2,000,000 cubic feet.....	$C_p=30,000$
2,000,000 to 3,000,000 cubic feet.....	$C_p=32,000$
3,000,000 to 4,000,000 cubic feet.....	$C_p=33,000$
4,000,000 to 6,000,000 cubic feet.....	$C_p=34,000$
6,000,000 to 10,000,000 cubic feet.....	$C_p=35,000$

b. Solving the problem given in paragraph 17g (1) by the Burgess formula gives—

$$\begin{aligned} H. P. &= \frac{\rho(\text{vol})^{2/3} v^3}{C_p} \\ &= \frac{(0.00237) (195,000)^{2/3} (88)^3}{20,000} \\ &= 273 \text{ horsepower.} \end{aligned}$$

20. Speed developed by given horsepower.—a. By transposing the horsepower formulas the following formulas are obtained for the speed developed by a given horsepower:

$$\begin{aligned} v &= \sqrt[2.86]{\frac{H. P. \times 550 \times E \times F}{C_D \times \rho \times (\text{vol})^{2/3}}} = \left(\frac{H. P. \times 550 \times E \times F}{C_D \times \rho \times (\text{vol})^{2/3}} \right)^{0.36} \text{ from paragraph 17f.} \\ &= \sqrt[3]{\frac{H. P. \times 550 \times E}{C' \times \rho \times (\text{vol})^{2/3}}} \text{ from paragraph 17g.} \\ &= \sqrt[3]{\frac{H. P. \times C_p}{\rho(\text{vol})^{2/3}}} \text{ from paragraph 19a.} \end{aligned}$$

b. *Problem and solution.*—(1) *Problem.*—An airship of 195,000-cubic-foot capacity has a power installation of two motors developing 150 horsepower each, or a total of 300 horsepower. The atmospheric density is standard. What speed should be obtained at full power?

(2) *Solution.*—Using Burgess' formula.

$$\begin{aligned} v &= \sqrt[3]{\frac{H. P. \times C_p}{\rho(\text{vol})^{2/3}}} \\ &= \sqrt[3]{\frac{300 \times 20000}{0.00237 \times (195000)^{2/3}}} \\ &= 90.8 \text{ feet per second} = 61.9 \text{ miles per hour.} \end{aligned}$$

c. Problem and solution.

(1) *Problem.*—An airship of 195,000-cubic-foot capacity is to be equipped with two engines developing a total of 300 horsepower. What speed can be expected using the following data?

- (a) Standard atmospheric density.
- (b) Shape coefficient, C_D is 0.0136.
- (c) Propeller efficiency, E , is 60 percent.
- (d) Envelope resistance is 40 percent of total resistance of completely rigged airship.

(2) *Solution.*—Using Prandtl coefficient.

$$v = \left(\frac{300 \times 550 \times 0.60 \times 0.40}{0.0136 \times 0.00237 \times 3,376.4} \right)^{0.85}$$

$$= 88.4 \text{ feet per second} = 60.3 \text{ miles per hour.}$$

d. Experience has shown the lower figure, as determined by Prandtl coefficients, to be more generally correct than the higher figure as determined by the Burgess formula.

21. Summary.—*a.* From study of the formulas it appears that the speed of an airship is proportional to the cube root of the horsepower, or vice versa the horsepower varies directly as the cube of the speed. Since power plant weights vary directly as the horsepower, the weight of the power plant varies also as the cube of the speed. A point is readily reached therefore beyond which it is not economical to increase the speed due to the excessive weights involved.

b. In still air the higher the speed the less economical the fuel consumption and the shorter the radius of action. This is not true when the airship is traveling against adverse winds. The study of just which air speed is the most economical will not be discussed in this manual as it properly belongs to the subject of navigation.

SECTION IV

STABILITY

	Paragraph
Variation of pressure distribution on airship hull.....	22
Specific stability and center of gravity of airship.....	23
Center of buoyancy.....	24
Description of major axis of airship.....	25
Types of stability.....	26
Forces and moments acting on airship.....	27
Damping moment.....	28
Longitudinal stability.....	29
Directional stability.....	30
Lateral stability.....	31
Summary.....	32

22. Variation of pressure distribution on airship hull.—a. In section II resistance of an airship was shown to be partly caused by increased nose pressure. Throughout the discussion the airship was considered to be flying on an even keel and in a straight line. All forces were parallel to the direction of flight. Before entering the subject of stability proper it will be necessary to show variation in pressure distribution on the hull when the airship is not flying as considered in section II, or, in other words, when transverse aerodynamic forces are present on the hull.

b. Figure 16 shows a typical pressure distribution on an airship hull when the airship is in horizontal flight in a straight line and on an even keel. This pressure distribution will be true whenever the line joining the tip of the nose with the tip of the tail (longitudinal axis) is

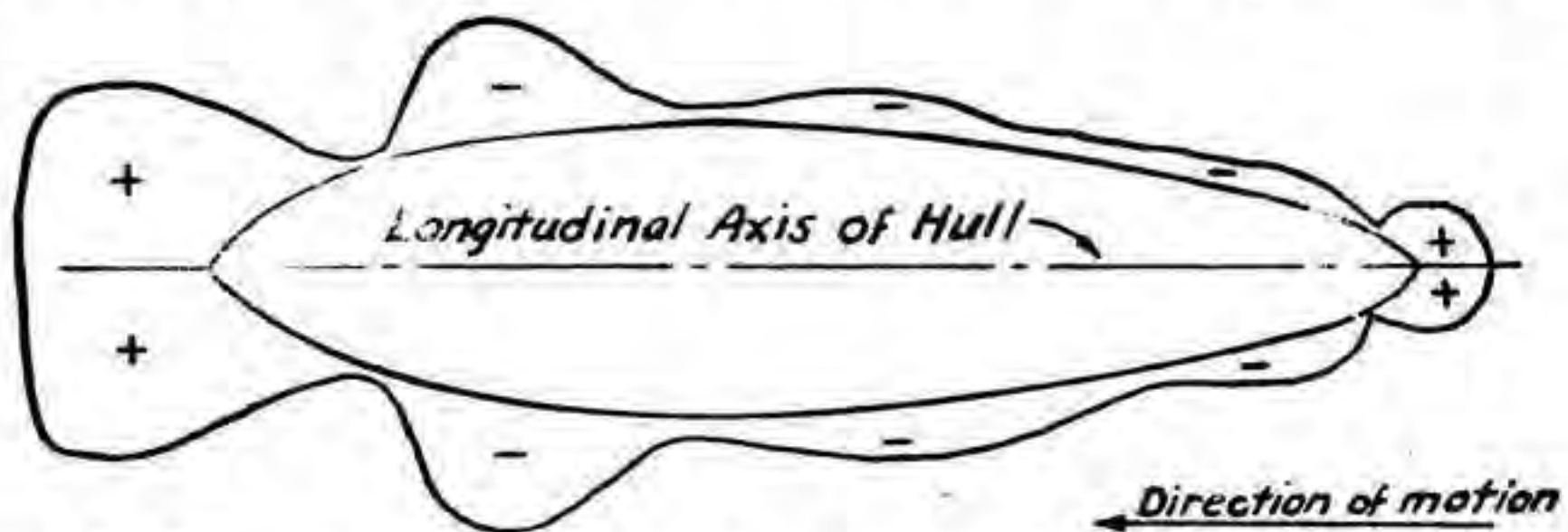

FIGURE 16.—Pressure distribution on airship hull (longitudinal axis parallel to direction of motion).

parallel with the direction of motion. Because an airship can be considered as a symmetrical solid of revolution, the pressure distribution has the following characteristics:

(1) Distribution depicted is uniform for any plane passed through the longitudinal axis.

(2) Varying reduced pressure exists from a section just in rear of the nose to a section just forward of the tail.

(3) Both nose and tail have positive pressure, but that on the tail is too small to be of much assistance to forward motion.

c. Figure 17 shows the distributions in pressure for an 18° angle of attack to the relative air. Other angles of attack have similar distributions. The distribution shown holds equally true whether the deviation of the axis from the direction of motion is in a horizontal or a vertical plane. When, for instance, the inclination is in the vertical plane, the following characteristics are observed:

(1) Positive pressure on the nose lies almost entirely in a zone beneath the axis.

(2) Plane of transition, *BC*, figure 17, is oblique with regard to the axis.

(3) Areas of reduced pressure are not symmetrical. Their maximum values occur beneath the stern and above the bow.

23. Specific stability and center of gravity of airship.—*a.* By specific stability is meant the property of the airship itself to maintain the relative position of its various parts unaltered in any contingency.

b. Conditions necessary for specific stability are the invariability of—

(1) Shape of envelope whether airship is in motion or not.

(2) Relative positions of envelope and cars and surfaces.

c. Methods used to maintain envelope shape are discussed in section I. Invariability of suspension of the car from the envelope is insured by a rectangular system of suspensions braced by diagonal cables

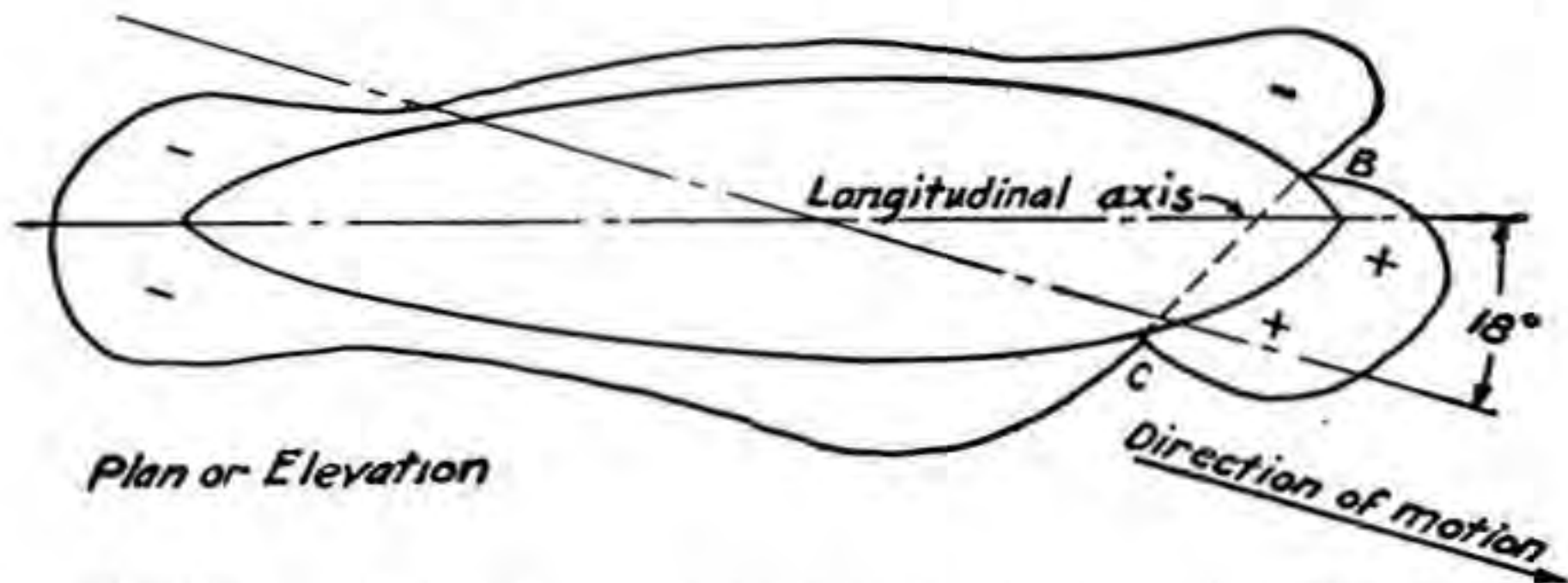

FIGURE 17.—Pressure distribution on airship hull (longitudinal axis inclined to direction of motion).

lengthwise and crosswise. These cables prevent any very appreciable motion of the car in regard to the envelope in case of oscillations of the airship in vertical longitudinal plane or in transverse plane. As will be shown later specific stability is absolutely essential to static stability of airships.

d. When invariability of suspensions has been assured, the position of the center of gravity of the airship may be determined. The center of gravity is the point at which may be assumed to be applied the total resultant of the various weights which oppose the lifting power of the gas. The position of the center of gravity is naturally not invariable since the live load of the airship is variable. Usually for non-rigid airships the center of gravity, *M*, falls above the car and either slightly above or slightly below the bottom of the envelope (see fig. 18).

24. Center of buoyancy.—The center of gravity of the ascensional force of the gas contained in the envelope is called the center of buoyancy. For an envelope which is not moving this point should

obviously be located on the vertical line passing through the center of gravity, M , and for an envelope which has the form of a symmetrical solid of rotation and which is full of gas, it should be located on the axis of the envelope itself.

a. However, when one or the other of the conditions mentioned is not fulfilled, that is, when the envelope is not a solid of rotation (as is the case with the Italian semirigid), or when it is not full of gas, or when with the airship partially filled with gas the axis is deviated in the vertical plane from the position of rest, the center of gravity, G , is not located on the axis in question, since this is supposed to be a straight line connecting the extreme end of the prow with the extreme end of the stern (see fig. 18).

b. That dissymmetry may cause this phenomenon is quite obvious. Moreover, if the airship is not full, even if the envelope is symmetrical the point G will be located above the axis. Lastly, if in addition to

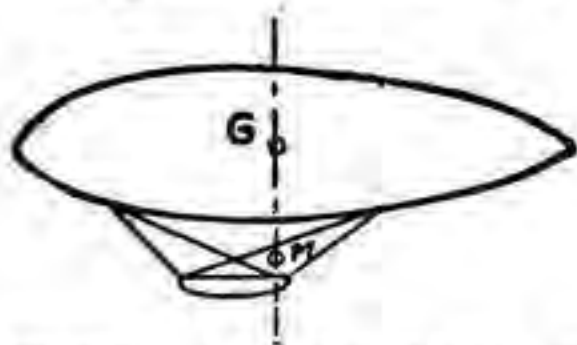

FIGURE 18.—Positions of centers of gravity and buoyancy in nonrigid airship.

not being full the envelope is inclined longitudinally, movement of the gas toward the high end will cause the point G to move in the same direction.

c. Without entering into a minute description of the various arrangements resorted to by different constructors in order to lessen as far as possible movement of the gas in the gas bag, assume, before going any further, that for an envelope with—

(1) Horizontal axis, the point G is on the axis when the envelope is full, and moves along a line through M perpendicular to the axis as the amount of gas in the envelope decreases.

(2) Oblique axis, the point G moves a moderate distance away from the above vertical, or at least it moves in such a way that the distance is a definite function of the angle of inclination of the envelope on the horizon.

25. Description of major axis of airship.—*a.* The airship hull, as previously stated, is a solid of rotation and hence symmetrical about the axis of rotation, $X'X$ in figure 19. Actually, due to the loading of a nonrigid, the shape of a cross section of the hull is more nearly elliptical with the major axis of the ellipse vertical, but the distortion is slight enough to be disregarded.

b. To conform to the system of nomenclature used by the National Advisory Committee for Aeronautics, the system of rotation outlined in figure 19 will be uniform throughout this manual.

c. Obviously any angular deviation whatsoever of the airship will be found to be either pitch, yaw, or roll, or a combination of these

AIRSHIP AERODYNAMICS

motions. With this fact in mind the types of stability now will be considered.

26. Types of stability.—*a.* Stability is defined as the tendency to return to a position of equilibrium after a small deviation from that position.

b. In airships stability is accomplished by two means, static and dynamic.

(1) Strictly speaking, the only real static stability is that which exists when the engines are stopped. Under this condition an air-

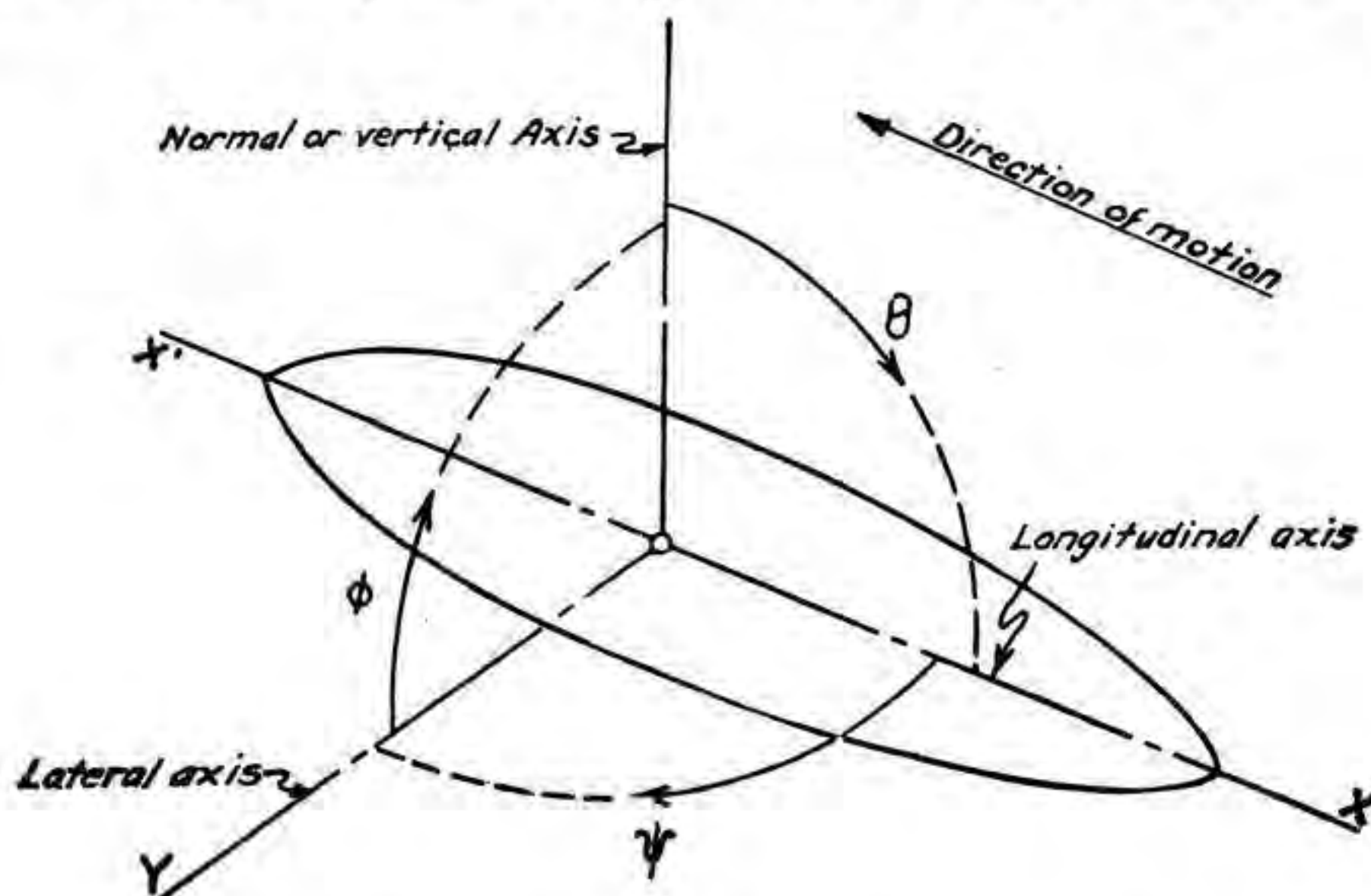

*Positive Directions of Axes and Angles
(Forces and moments shown by arrows)*

Axis	Moment about axis		Angle		Velocities				
	Designation	Symbol	Designation	Symbol	Linear (component along axis)	Angular			
Longitudinal	X	X	Rolling	L	Y → Z	Roll	Φ	u	p
Lateral	Y	Y	Pitching	M	Z → X	Pitch	Θ	v	q
Normal	Z	Z	Yawing	N	X → Y	Yaw	Ψ	w	r

FIGURE 19.—Chart showing axes of airship and conventional symbols related thereto.

ship is statically stable if it tends to return toward initial condition of steady motion whenever slightly disturbed from that motion. This requirement is not dependent upon the plane in which deviation from steady motion occurs, and, as will be shown later, an airship is statically unstable in yaw.

(2) Dynamic stability is the stability effected by action of the air stream upon controlled surfaces. Were it not for these surfaces airships would become unmanageable at very slow speeds.

c. Stability may be classified further. An airship in steady flight has three types of stability, pitch or longitudinal, yaw or directional, and roll about the longitudinal axis. While these stabilities are all correlated in the case of an airplane, this is not the case with an airship, the three types of stability being independent of each other.

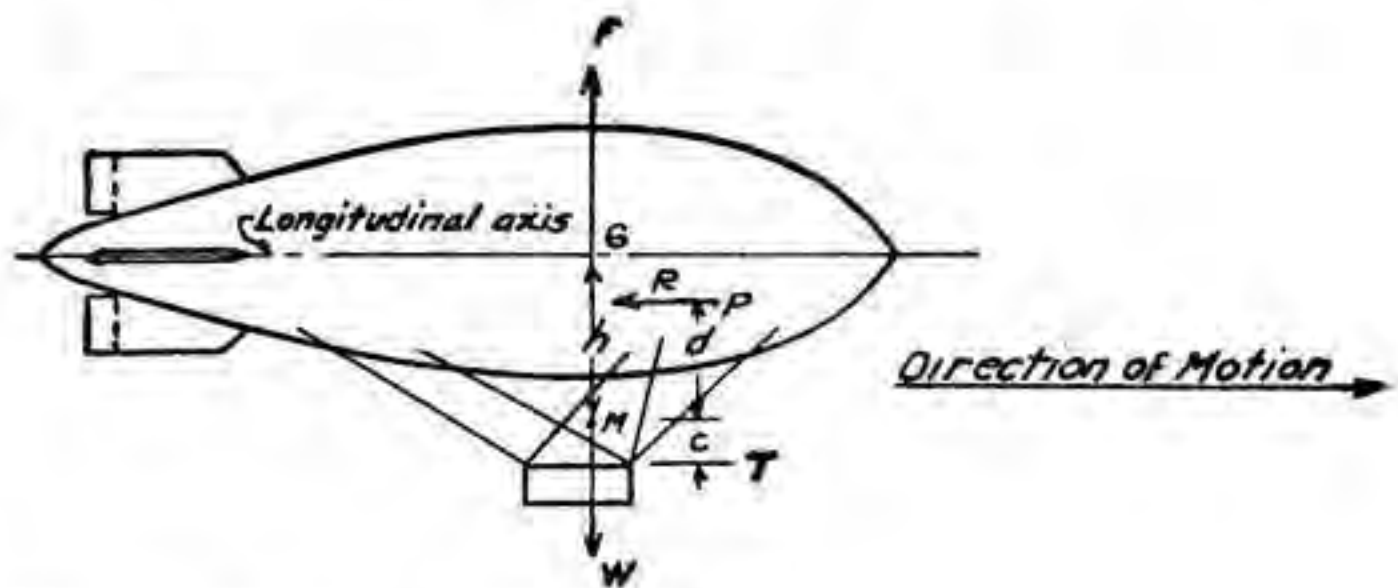

Airship traveling horizontally in Static equilibrium. Longitudinal axis coincident with direction of motion.

FIGURE 20.—Forces on airship in horizontal flight.

d. The following discussion will be based upon the assumptions for each situation that—

- (1) Ascensional force remains constant.
- (2) Total weight remains constant.
- (3) Speed remains the same.
- (4) Form of airship remains unchanged.
- (5) Center of gravity and center of buoyancy remain fixed.
- (6) Controls remain in neutral.

27. Forces and moments acting on airship.—a. Suppose an airship flies along a horizontal right-line trajectory while its longitudinal axis makes an angle of 0° with the flight path, then the airship will be acted on by the following forces and moments (see fig. 20).

- (1) Forces:
 - (a) L_g = Lift of inflating gas acting through center of buoyancy, G .

AIRSHIP AERODYNAMICS

(b) W = Total weight of dead and live loading, acting through center of gravity, M .

(c) R = Resistance of envelope and appendages, acting through center of pressure, P .

(d) T = Propeller thrust, acting parallel to axis of envelope at distance c below M .

(2) *Moments about M :*

(a) Moment $L_g = L_g \times 0 = 0$.

(b) Moment $W = W \times 0 = 0$.

(c) Moment thrust-resistance couple = $T(c+d)$.

Obviously, for static equilibrium and constant velocity—

$$\begin{aligned} L_g &= W \\ R &= T \end{aligned}$$

However, if the airship is riding on an even keel, the moment of thrust and resistance is unbalanced and will tend to nose the ship up. For this reason airships are customarily trimmed a few degrees nose heavy when full of gas.

b. Suppose that some force such as a gust of air should give the longitudinal axis a slight tilt to the horizontal. Depending on static condition of airship and direction of inclination, six cases which arise are—

(1) *Case No. 1.*—Airship in static equilibrium, nose tilted up. In this case, if the angle between the longitudinal axis and the direction of motion is denoted by θ and the angle between the direction of motion and the horizontal by α , since the airship climbs at the angle of tilt, $\theta = 0^\circ$ and the airship will climb at the angle, α .

(2) *Case No. 2.*—Airship in static equilibrium, nose tilted down. As before, $\theta = 0^\circ$ and the airship will descend at the angle, α .

(3) *Case No. 3.*—Airship statically heavy, nose tilted up. In this event the airship will climb at a lesser angle than the amount of tilt, and the longitudinal axis will make the angle $\alpha + \theta$ with the horizontal.

(4) *Case No. 4.*—Airship statically heavy, nose tilted down. Because of the heaviness, the airship will descend at a greater angle than the inclination, the longitudinal axis making an angle of $\alpha - \theta$ with the horizontal.

(5) *Case No. 5.*—Airship statically light, nose tilted up. This case is similar to case No. 4. The longitudinal axis makes the angle $\alpha - \theta$ with the horizontal.

(6) *Case No. 6.*—Airship statically light, nose tilted down. Here the airship will descend at a lesser angle than the inclination and the angle between the horizontal and the longitudinal axis will equal $\alpha + \theta$.

c. Figure 21 shows case No. 3. Figures showing the other cases would be quite similar. Referring to figure 21, the following forces, lever arms, and moments, all general to cases Nos. 1 to 6, inclusive, are noted:

(1) *Forces:*

(a) L_g = Lifting force of gas.

(b) W = Total weight.

(c) F_e = Resultant air force on hull.

(d) L_e = Vertical component of dynamic force on hull.

(e) R_e = Horizontal component of dynamic force on hull.

(f) F_s = Resultant force on tail surfaces.

(g) L_s = Lift of tail surfaces.

(h) R_s = Drag of tail surfaces.

(i) T = Thrust of propellers.

(j) t = Horizontal component of propeller thrust.

(k) L_t = Vertical component of propeller thrust.

(2) *Lever arms about G.*—Lever arm of—

(a) $W = h \sin (\alpha \pm \theta)$.

(b) $L_g = 0$.

(c) $T = (c + h)$.

(d) $F_s = a$ (assuming F_s perpendicular to the surfaces).

(e) $L_s = a \cos (\alpha \pm \theta)$.

(f) $R_s = a \sin (\alpha \pm \theta)$.

(g) F_e varies with the position of P , which in turn depends on the angle θ .

(h) $L_e = b \cos (\alpha \pm \theta)$.

(3) *Moments about G.*—Moment of—

(a) Weight. Defined as static righting moment. It is present irrespective of speed and at all times equals $W h \sin (\alpha \pm \theta)$.

(b) Propeller thrust, $T (c + h)$.

(c) F_e . Due to increased pressure below the hull, F_e tends to rotate entire airship in a positive direction about M . This is assisted by reduced pressure beneath the tail (see fig. 17). The force below nose and tail are opposite in direction. Their difference, since the nose force is slightly the greater, is called dynamic lift of hull. However, both forces cause rotation in the same direction, and their moment is referred to as dynamic upsetting moment, M_e . It will be evaluated later.

NOTE.—The force beneath the tail has been omitted from the figure in order to avoid confusion in the drawing, the entire upsetting moment being treated as though it were caused by the increased pressure under the nose.

(d) Tail surfaces, M_s . This opposes the dynamic upsetting moment. $M_s = L_s a \cos (\alpha \pm \theta) + R_s a \sin (\alpha \pm \theta)$.

28. Damping moment.—a. There is one moment which has not been discussed. If the airship, oscillating as it travels along its path, is considered as having two motions, one of translation as a whole and one of rotation about the center of gravity, superposed on each other, it is clear that during that portion of the angular oscillation in which the nose is rising, every part of the airship forward of the center of gravity is moving upward, while all parts to the rear of that point, including the tail surfaces, are moving downward.

b. There will then be an upward pressure of the air against the rear part of the airship and a downward pressure on the forward part. The upward and downward forces approximately cancel each other

Ship heavy-Nose elevated

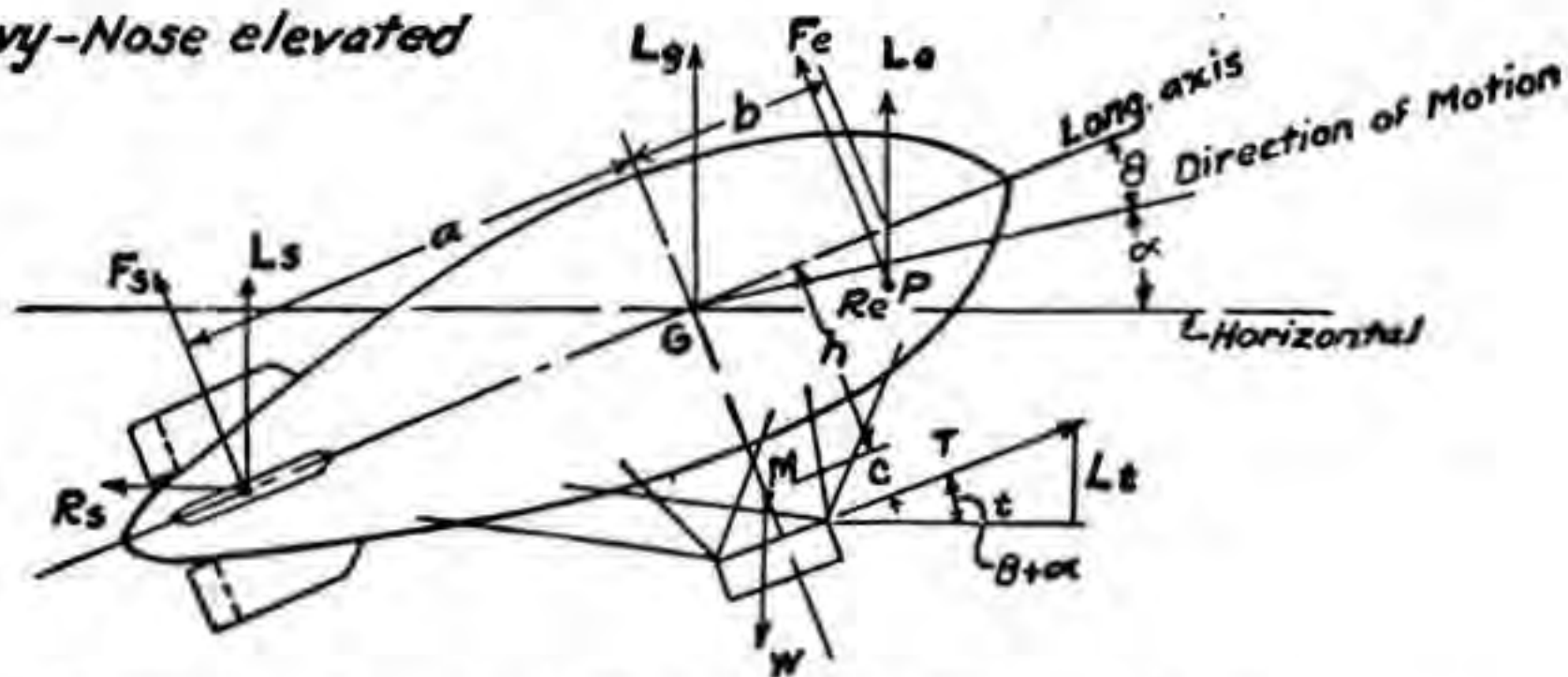

FIGURE 21.— Forces on airship in inclined flight (case No. 3).

so far as translational motion is concerned, but they act together to give a moment tending to depress the nose and so to resist the motion existing. If the rotation were such that the nose was descending, a moment tending to raise the nose would appear. This is called the damping moment as it is entirely independent of position and attitude, but acts always in such a manner as to oppose existing motion and bring the airship to steady flight. Oscillations of the airship are damped exactly as oscillations of a pendulum are damped if the bob is light and has a large vane attached to it. Damping moments may be determined experimentally in a wind tunnel, but the mathematical theory when these moments are quantitatively taken into account is extremely complex and will not be discussed here.

29. Longitudinal stability.—a. For longitudinal stability, the sum of the restoring moments must exceed the upsetting moments. In the case illustrated—

$$M_s + Wh \sin (\alpha + \theta) > M_e + T(c + h).$$

However, this relation does not hold in each case. For instance, the static couple, $Wh \sin (\alpha \pm \theta)$, works against the thrust couple when the airship is in a climbing attitude and with it when the airship is in a descending one. The dynamic moment of the hull, on the other hand, assists the righting moment in case Nos. 4 and 5, but opposes it in case Nos. 3 and 6. Case Nos. 1 and 2 are unimportant as will be shown later. Obviously case Nos. 3 and 6 are the ones which must be considered when designing for stability.

b. The static righting moment is nearly a right-line function of the angle, θ . So for practical purposes is the upsetting moment. But whereas the righting moment is independent of the velocity, the upsetting moment varies as the square of the speed. Obviously as the speed increases a velocity will be reached where the upsetting moment just equals the righting moment. This is called the critical speed.

c. For an airship without control surfaces, neglecting for the moment propeller thrust and resistance, the critical speed would be reached when—

$$M_c = Wh \sin (\alpha \pm \theta).$$

By the formula of Doctor Munk:

$$M_c = (\text{Vol}) \frac{\rho}{2} v^2 (k_2 - k_1) \sin 2\theta$$

where k_2 and k_1 are constants to correct for the fact that masses of air are carried along with the hull in both transverse and longitudinal motion. Tables of values of k_2 and k_1 are given in National Advisory Committee for Aeronautics Report No. 184. From the Munk equation it appears that M_c varies directly as $\sin 2\theta$ and as the square of the speed. Combining the constant factors in the formula into one constant, M_c :

$$M_c = M_c \sin 2\theta v^2.$$

Hence the relation for critical speed without fins becomes—

$$M_c \sin 2\theta v_c^2 = Wh \sin (\alpha \pm \theta)$$

$$v_c = \sqrt{\frac{Wh \sin (\alpha \pm \theta)}{M_c \sin 2\theta}}$$

where v_c = critical speed.

This would give a very low critical speed. For an Italian military airship of the M type the critical speed without fins is 29 miles per hour.

d. Introducing the tail surfaces gives a much higher value of the critical speed. From the relations given in *a* above for case No. 3, the

equation of stability at the critical speed, omitting the thrust-resistance couple, is—

$$F_s a + Wh \sin (\alpha - \theta) = M_e.$$

Since the force on an inclined plate is approximately a right-line function of the angle of inclination,

$$F_s = C_1 \theta v_c^2$$

where C_1 is a constant combining the surface coefficient and the fin area. As before—

$$M_e = M_c \sin 2\theta v_c^2.$$

Hence

$$M_c \sin 2\theta v_c^2 = C_1 \theta v_c^2 a + Wh \sin (\alpha + \theta)$$

$$v_c = \sqrt{\frac{Wh \sin (\alpha + \theta)}{M_c \sin 2\theta - C_1 \theta a}}$$

e. For a condition of static equilibrium, as stated in paragraph 27*b*, the flight path theoretically coincides with the longitudinal axis. Hence θ becomes zero and v_c becomes infinite. This agrees with the theoretical facts since with no angle of attack to the air stream the transverse dynamic forces become zero for all speeds and the static righting moment would restore quickly the airship to the horizontal position. Actually, however, this can never be practically true, since inertia of the airship retards change in direction of motion from the horizontal path and prevents the airship immediately adopting a line of flight coincident with its longitudinal axis.

f. In the preceding discussion the controls have been considered to be held in neutral. Actually by varying his elevator angle, the pilot may increase materially the effect of the control surfaces. This further increases the speed which the airship may travel without loss of control. If the airship is not longitudinally stable, or if in other words it is being operated above its critical speed, the pilot must correct deviations from the chosen path as soon as they appear, while on a stable airship these deviations would be capable of self-correction if left manually uncorrected.

g. The statical righting moment varies as the fourth power of a linear dimension of the airship, the ascensional force F being proportional to the volume and so to the cube of a linear dimension. All aerodynamic moments, on the other hand, both on the hull proper and on the tail surfaces, vary as the cube of a linear dimension. The critical speed is therefore proportional, for geometrically similar airships, to $\sqrt{\frac{L^4}{L^3}}$ or to the square root of a linear dimension. A large airship can therefore be stabilized with tail surfaces proportionally smaller than

those necessary on a small one traveling at the same speed. An unstable airship requires closer attention from the pilot than does one which is stable, but it is not necessarily either difficult or dangerous to operate and has the advantage of being more easily maneuverable than the more stable types.

30. Directional stability.—*a.* Directional stability is maintained in part by use of vertical fixed fins and rudder. When the rudder is set in neutral it acts as additional fin surface, but the total fin surface is never large enough to provide complete directional stability. Since there is no statical restoring moment to overcome a horizontal deviation from the flight path, maintenance of directional stability devolves upon the pilot who must correct any deviations as soon as they appear. Otherwise a deviation once started will tend to increase until the airship is traveling in a circle of so small a radius that the damping moment balances the turning moment due to pressure on the nose. This is quite different from the condition of longitudinal stability where the elevator can be left locked in any particular position and the airship will return to its original attitude if atmospheric disturbances have momentarily changed that attitude.

b. As soon as there is any deviation from the straight line of flight the air strikes on the side of the envelope and sets up a moment tending to turn the airship farther from its original course. This moment corresponds exactly to the upsetting moment, M_e , which opposes longitudinal stability. There is then an unbalanced moment which tends to give the airship an angular acceleration and so to turn her more and more rapidly. At the same time the lateral force on the envelope, which corresponds to the dynamic lift, is increasing and furnishes the necessary centripetal force to keep the airship traveling in a circular path. It is quite true that a force resisting this circling is exerted by the vertical surfaces, but, as mentioned above, the vertical fin surfaces are never large enough to provide full stability, and the rudder must be used to assist them. Use of the rudder will be more fully discussed in section V.

31. Lateral stability.—*a.* Stability in roll, which is a very difficult problem in airplanes, is taken care of almost automatically in airships, since the same statical restoring moment acts with regard to roll as with regard to pitch and there is no dynamic upsetting moment to oppose it. The only rolling motions are those due to side gusts against the car and bag and those due to centrifugal force when turning. The moments of these forces are overcome immediately by the large restoring moment due to the low position of the center of gravity. Roll-

ing may be very uncomfortable because of the short and snappy period, but there is never any danger of its reaching an excessive value.

b. The static stability of an airship with regard to both roll and pitch may be increased by lowering the car, but this gives equilibrium only at the sacrifice of ease of control and efficiency, since lowering the thrust line increases the thrust moment and lowering the car increases length of suspensions and hence parasite resistance.

32. Summary.—*a.* Airship stability may be summarized as follows:

(1) Airships are very stable about their lateral axis. In this regard the designer has no trouble whatsoever.

(2) Airships must be designed carefully to give longitudinal stability. This problem is however of more interest to the designer than to the pilot.

(3) Airships are statically unstable in yaw, necessitating the closest attention on the part of the direction pilot to counteract circling by means of the rudder.

b. No concrete problems have been given in this section as the application of fundamentals covered therein will be shown in section V.

SECTION V

CONTROL

	Paragraph
General types.....	33
Directional.....	34
Altitude.....	35
Reverse.....	36
Application of dynamic control to operation of airships.....	37

33. General types.—*a.* Control of airships may be subdivided into two classes, directional and altitude. On nearly all airplanes these two types of control are so interrelated as to necessitate their both being performed by one pilot. In airships this is not the case, and on all but the smallest airships two pilots are utilized, one for direction, one for altitude.

b. For efficient performance the two pilots should be familiar with each other's style of flying and constantly alert to render each other assistance. For instance, to obtain the proper additional superheat to effect a landing (see TM 1-325), the altitude pilot may desire a longer approach than usual. The direction pilot should so arrange the course as to meet needs of the situation. Instances of the value of coordination are too numerous to mention, but fortunately capable pilots have little difficulty in achieving desired results.

34. Directional.—*a.* As stated in paragraph 33, the direction pilot is charged with control of the course of the airship in a horizontal plane. On cross-country flights his problem resolves itself into that of holding the course required by the mission of the airship. Once the course is set, the airship will hold its own course unless acted on by some exterior forces such as gusts. These must be overcome by prompt application of the rudder in the opposing direction. When flying in very gusty air it is impossible to prevent yawing, but a good pilot can keep the magnitude of the oscillations from exceeding a few degrees. Then since the gusts strike about equally from both sides the mean course of the airship will be the one desired.

b. It is essential that the pilot have a clear conception of the reaction to rudder control of the airship in a turn. When it is desired to turn to the right, for example, the rudder is put over to the right. The instantaneous effect of this rotation is to produce a force to the left acting on the right side of the rudder. This force to the left has a dual effect. In the first place, it gives the moment about the center of gravity tending to turn the nose to the right. In the second place, it moves the entire airship to the left. As the airship moves to the left and as its nose turns to the right, both motions combine to cause the air to strike on the left of the envelope and so to turn the nose still farther to the right. After this has proceeded for an interval, the pressure on the left-hand side of the nose becomes equal to that on the right-hand side of the rudder and the total resultant pressure is therefore zero, but since one force is applied to the front and the other to the rear, there is a resultant turning moment tending to continue the twisting to the right. As the motion proceeds still farther, the force on the left-hand side of the envelope becomes greater than the force on the right-hand side of the rudder and there is a centripetal force to the right so that the airship starts to move to the right. If the rudder is *left in hard* or even if it is turned to neutral, this turning to the right will continue, and in order to check the circling it is necessary to put the rudder over to the left of the envelope.

c. The turning radius is governed by the damping moment on the envelope and is greater for an airship of large fineness ratio than for one where this ratio is small. It should be one of the first concerns of the pilot whenever he assumes control of a new type of airship to familiarize himself with its turning radius. Otherwise he might very conceivably endeavor to execute a turning maneuver where the space limitation was insufficient.

d. Referring again to the turn described in *b* above, it appears, curiously enough, that the first effect on putting the rudder over to

the right is to shift the airship slightly to the left so that if the airship were being flown along close to the right side of a wall or other obstruction, it would not be safe to put the rudder over sharply to the right in order to turn to the right and get away from the obstruction, as the immediate effect of such an action would be to drive the airship into the wall. The approximate path of the airship when the rudder is put over to the right, together with several successive positions of the axis of the airship, are indicated in figure 22.

e. It occasionally happens, especially when flying through foggy atmosphere, that an obstacle will suddenly loom up in front of the

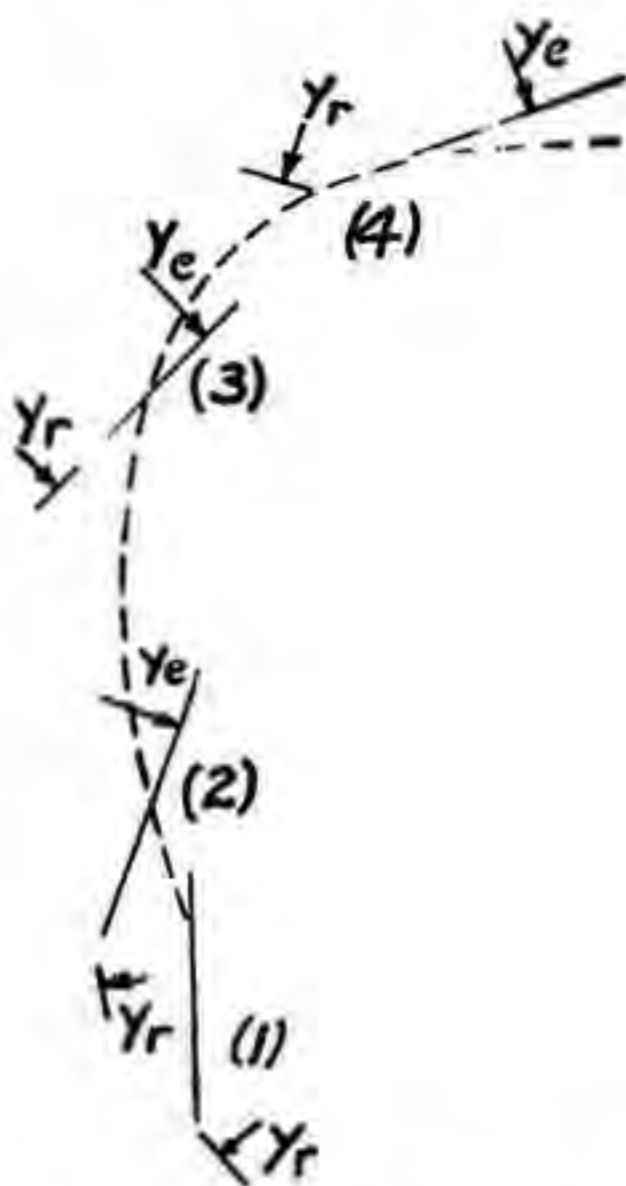

FIGURE 22.—Action of airship in a turn.

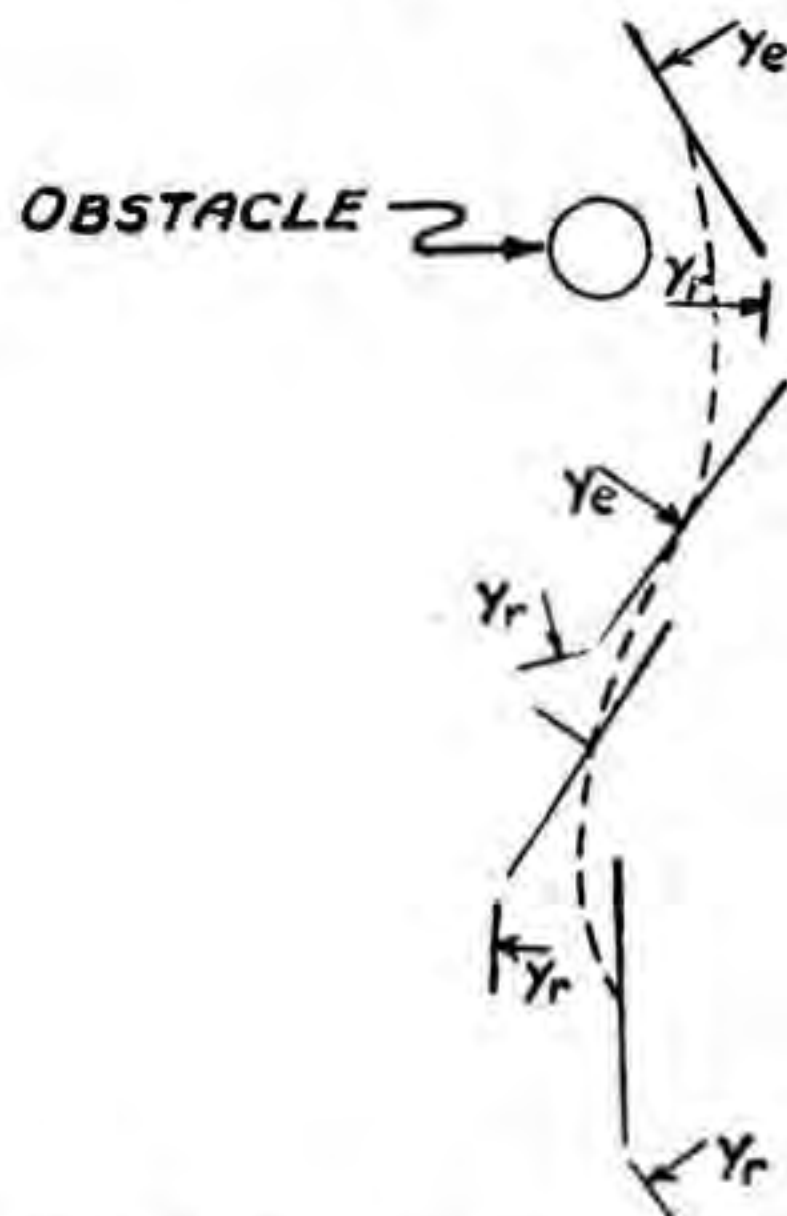

FIGURE 23.—Action of airship in avoiding an obstacle.

airship. To miss the obstacle the pilot must first put over the rudder to deflect the nose of the airship and then completely reverse the rudder. In this case the action is as shown in figure 23.

f. There is one other situation in which the direction pilot must exercise caution. As the airship turns under action of the rudder, centrifugal force acting on the center of gravity will swing the car to the outside. This action will so tilt the hull that the rudder will become in part an elevator. Air striking on the inside of the rudder will depress the nose of the ship. This depression can be stopped by prompt application of the elevator controls by the altitude pilot. However in some cases, especially when near the ground with a heavy airship, the altitude pilot may be unable to use the elevators without endangering the tail of the airship. Hence the direction pilot must

be very careful to turn a heavy airship slowly when at low altitudes. On the other hand, he can very materially assist the altitude pilot in holding a light airship down by making abrupt turns.

35. Altitude.—*a. Methods.*—(1) Altitude control of airships is effected by two means, static and dynamic. The former method is discussed in TM 1-325.

(2) Static means of control must always be augmented by dynamic means. Even though an airship takes off in perfect equilibrium it will not remain so. Changes occur in the static lift due to changes in meteorological conditions and loading is being varied constantly by consumption of fuel. To balance inequalities between loading and lift, dynamic means must be used.

b. Trim of airship.—(1) In the study of stability, to simplify the discussion the subject of trim of the airship was omitted. A thorough knowledge of trim is however essential to intelligent control of the airship.

(2) Under action of the static righting moment, the center of gravity of the airship will lie directly below the center of buoyancy. If the line joining these two points is at right angles to the longitudinal axis, this axis is horizontal, and the airship is said to be trimmed in neutral. If, on the other hand, due to the manner of loading or to location of the air in the ballonets of a pressure airship, the longitudinal axis is inclined to the horizontal when the center of gravity is directly below the center of buoyancy, the airship is said to be trimmed nose heavy or tail heavy, as the case may be. The application of trim to dynamic control of airships is discussed in paragraph 37.

c. Climbing and descending.—(1) Change in altitude is accomplished dynamically by use of elevators in conjunction with thrust of propellers. To simplify the following discussion the airship is assumed to be flying with neutral trim and in static equilibrium. If it is desired to climb, the altitude pilot raises the elevators which causes an action in the vertical plane similar to that described in paragraph 34 for turning in a horizontal plane. However, in this case, the elevators must be held in the raised position to prevent the static righting moment bringing the longitudinal axis back to the horizontal.

(2) It should be especially noted that when the elevator is raised the tail of the airship actually descends. For this reason extreme caution should be used in use of the elevator when the airship is near the ground.

36. Reverse.—*a.* There is one curious paradox in control of airships at very low speeds. If the speed falls below a certain definite

value known as the "reversing speed," control becomes reversed and pulling up the elevators causes the airship to descend, although it turns the nose upward. The reason for this is that at low speeds (for most types about 15 miles per hour) the air forces are entirely unimportant in comparison with the static restoring moment due to the weight when the airship is inclined. Then if the elevators are pulled up, the momentary effect is to turn the nose upward, but the axis will incline only at a very small angle before the static restoring moment becomes equal to the moment due to the force on the elevators, and the inclination will then cease to increase. If this angle of inclination is held to a small enough value, the dynamic force on the nose will be less than the downward force on the elevators. There will then be an excess of downward force and the airship will be thrust downward as a whole. This reversing speed offers a reason for not making the static stability excessive, since reversing speed increases as the center of gravity is lowered and the resulting difficulty in control becomes more serious where the static stability is large.

b. The phenomenon of reverse control is especially apparent if the airship is trimmed quite nose heavy. Then any attempt on the part of the pilot to lift the nose at slow speeds is resisted by the static moment. The decrease in the dynamic thrust downward on the nose will be less than the gain in the downward force on the elevator and the airship as a whole will descend.

c. The particular situation just described is one of the most serious into which the airship can be brought. It is of most frequent occurrence when a nose heavy airship is being brought to a landing and due to loss of superheat becomes statically heavy. The airship will descend as a result of this heaviness and, if the speed is below reversing speed, application of the elevators at that speed will simply cause more rapid descent.

d. The only recourse of the pilot in this situation, unless his airship is equipped with reversing propellers, is to throw ballast or materially increase his speed beyond the reversing limit as he raises the elevators. When the airship is quite near the ground there may not be sufficient altitude to execute the latter maneuver without striking the ground with the tail. If his airship is equipped with reversing propellers, the pilot can cause the airship to ascend while the nose is down by merely reversing the direction of propeller rotation.

e. There is one other situation in which reverse control occurs. The maximum dynamic lift on the hull occurs at an angle of attack of 10° or 11° for most types of airships. If an airship is flying with this angle of attack and the elevators are raised so as to increase the angle

of attack beyond that giving the maximum lift, the dynamic lift naturally decreases. At the same time the downward thrust on the elevators is increased. The gain in the upward component of the propeller thrust at reversing speed or below will not compensate for the loss in lift just described and the airship will be under the action of a greater resultant downward force than at the start.

f. The opposite effect to that described in *e* above occurs when an airship is trimmed tail heavy and the elevator is depressed. In this case the whole airship will rise.

g. It might appear that reverse control would be a source of great annoyance to the pilot. This is not the case when the phenomenon is

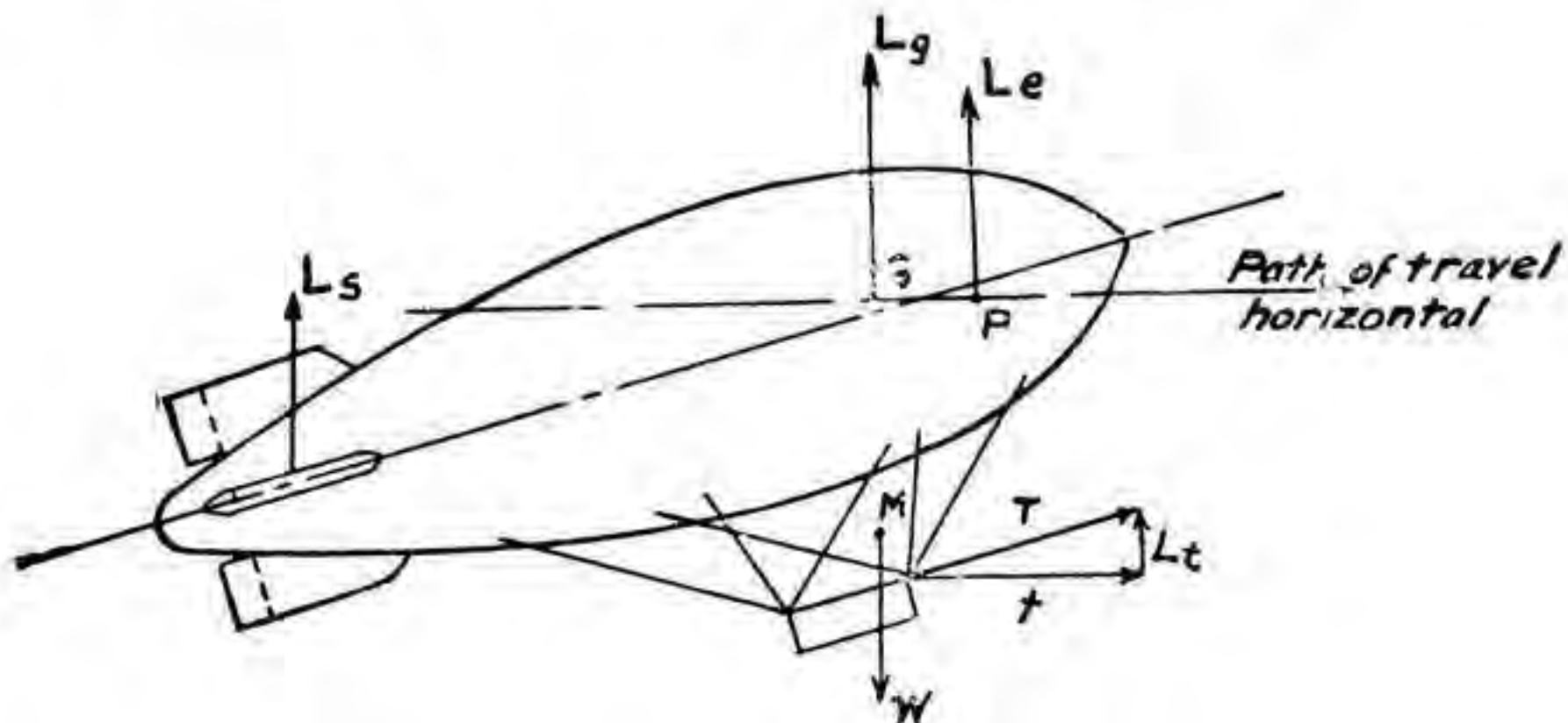

FIGURE 24.—Flight at constant altitude (airship statically heavy, trimmed tail heavy, elevators neutral).

properly understood. In fact, many maneuvers are executed by intelligent use of reverse control, for example, heavy take-off. This is described in paragraph 37.

37. Application of dynamic control to operation of airships.—*a.* The three major maneuvers in airship operation which are assisted by dynamic control are—

- (1) Flight at constant altitude.
- (2) Take-off.
- (3) Landing.

These operations are fully covered in TM 1-310 and are discussed but briefly here to bring out the aerodynamic principles involved therein.

b. As soon as the take-off is completed and the obstacles in the immediate foreground cleared, the pilot climbs to the altitude at which he desires to cruise. He then trims the airship so that with the controls in neutral the algebraic sum of the vertical forces is zero. Since the airship is almost never in static equilibrium, one of two situations will prevail, static heaviness or lightness.

(1) Figure 24 shows the case in which the airship is statically heavy and trimmed nose light. In this case the equation of vertical forces to give constant altitude flight with neutral controls becomes—

$$W = L_g + L_e + L_t + L_s$$

The pilot may be called upon to fly a heavy airship on account of various reasons such as—

- (a) Collection of moisture if rain is encountered.
- (b) Leakage in envelope.
- (c) Loss of superheat.
- (d) Heavy take-off.

Most airships can carry about 10 percent of their gross lift dynamically at the surface of the earth. Since the dynamic lift varies as the air density, it decreases with altitude. Table III shows results of some experiments on an Italian M type airship at full speed:

TABLE III.—*Lift of Italian M type at full speed*

[In pounds]

Angle of inclination in radians	Altitude, 3,000 feet				Altitude, 10,000 feet				Altitude, 16,500 feet			
	Total lift	Lift of envelope	Lift of propellers	Lift of fins	Total lift	Lift of envelope	Lift of propellers	Lift of fins	Total lift	Lift of envelope	Lift of propellers	Lift of fins
0.03	1,224	330	60	834	1,012	269	48	695	839	218	40	481
0.06	1,855	612	125	1,118	1,542	495	101	946	1,287	400	82	805
0.09	2,290	810	200	1,280	1,914	657	163	1,095	1,608	530	130	948
0.12	2,497	913	290	1,294	2,101	742	235	1,124	1,778	599	189	990

(2) Figure 25 shows the case in which the airship is flying statically light at constant altitude with controls in neutral. In this case the equation of the vertical forces becomes—

$$L_g = W + L_e + L_t + L_s$$

(3) In the unusual case in which the airship is in perfect static equilibrium, it will be necessary to trim the airship about 2° nose heavy to overcome the upturning moment of the propeller thrust. So trimmed the airship will fly on an even keel at cruising speed. The motorized observation balloon, having only one ballonnet, cannot be trimmed for an individual flight. An approximate 2° nose heavy

trim is given this type of airship during initial inflation by proper adjustment of car suspension rigging.

c. It is customary to take off large semirigids and rigids statically light, but nonrigids are taken off as much as 6 or 7 percent heavy.

(1) The light take-off may be made with the airship in any trim from tail heavy to a few degrees nose heavy. In the latter case the airship should be free-ballooned to a safe altitude before the motors are opened. The light take-off presents little difficulty.

(2) For the take-off when the airship is in static equilibrium the trim should be neutral or a few degrees tail heavy, preferably the latter. In this case the car party of the maneuvering crew gives the airship a toss upward, the men on the nose of the car throwing their end up first, then the men to the rear throwing up their end. This gives

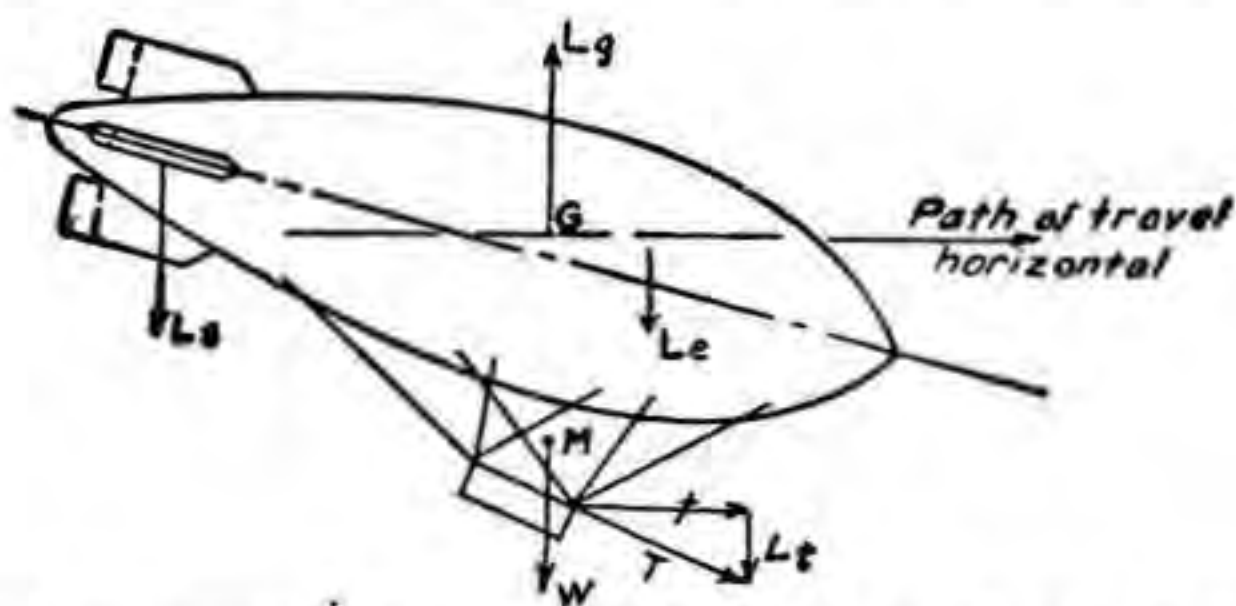

FIGURE 25.—Flight at constant altitude (airship statically light, trimmed nose heavy, elevators neutral).

the airship an initial angle of attack to the air stream. When clear of the party the pilot opens his motors and raises his elevators slightly. The thrust of the propellers assisted by the slight force on the elevators will further raise the nose of the airship and it will climb rapidly.

(3) For the heavy take-off the airship must be carefully trimmed tail heavy. The amount of the trim varies with degree of heaviness, type of airship, and wind velocity. If there is a good wind blowing it gives the airship an initial air speed to assist the ascent. Experience has shown that an airship of the TC type with a trim of 9° tail heavy will take off 700 pounds heavy in still air. For this degree of heaviness the car party should be augmented to at least 20 men and 4 men should be assigned to lift on the tail surface. At the proper signal the car is thrown up, nose first as before. The elevators should be depressed about 10° and as the pilot opens his motors he will find it necessary to depress the elevators fully to keep the tail from striking the ground. Action of the airship in rising is a pure case of reverse control. The air from the slipstream of the propellers strikes the

AIRSHIP AERODYNAMICS

elevators and gives the tail a positive lift. At the same time the trim of the airship will keep its nose elevated so that there will be the familiar dynamic lift on the hull surface and the vertical component of the propeller thrust to assist the ascent. In this case—

$$L_g + L_e + L_t + L_s > W$$

d. The most difficult maneuver which confronts the pilot is the landing. This operation may be divided into three parts, as follows:

- (1) Weigh-off.
- (2) Approach.
- (3) Arrival at the landing party.

e. Weigh-off is made at a safe altitude (1,000 feet for large airships, 250 to 500 feet for smaller ones). For this maneuver controls are

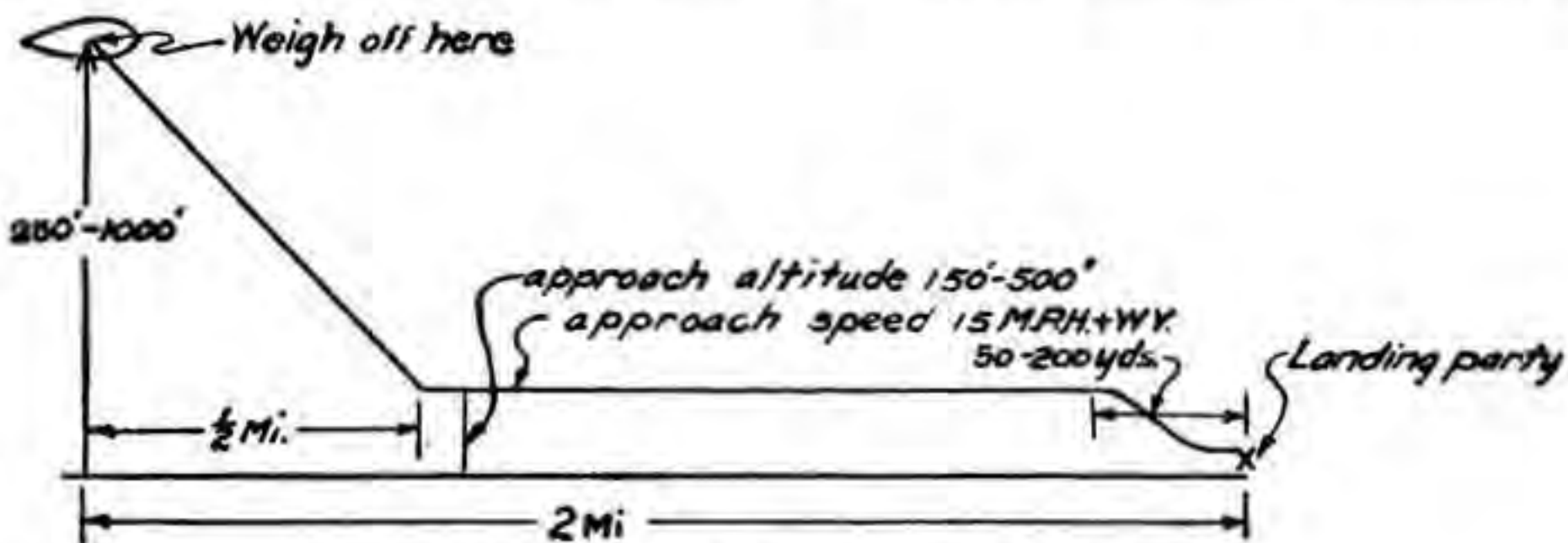

FIGURE 26.—Approach of an airship to a landing.

placed in neutral and air speed reduced to as low a speed as possible. The airship will quickly assume an attitude determined by the trim, which can be read from the inclinometer. At the same time the pilot can notice whether the airship is rising or descending statically. It is useless to bring the airship to an even keel to eliminate dynamic lift caused by unavoidable residual speed incident to idling propellers, as this would, in reality create a dynamic thrust on the tail surfaces. As a result of the knowledge of condition of the airship derived from weigh-off and after due consideration of existing meteorological conditions, the pilot is ready to make the approach.

f. The principal object of the approach is to determine in advance of the arrival at the party the behavior of the airship at landing speed. Figure 26 gives a graphical picture of the approach.

(1) From the altitude of weigh-off the airship is brought quickly to the altitude of approach. This varies from 150 feet for a nonrigid to 500 feet for a large rigid, depending in some measure on gustiness of the atmosphere. During the descent the pilot arranges the trim he estimates to be necessary to make the landing. On arrival at the

approach altitude the speed of the airship is reduced to 15 miles per hour plus the wind velocity. This is an excellent approach speed.

(2) The pilot now wishes to check behavior of the airship at this speed. Controls are placed in neutral and if the trim is correct the airship will maintain constant altitude in a manner described in *b* above. If it does not, it is necessary to adjust further the trim to effect that result. The principle is exactly the same whether the airship is statically light or heavy. During remainder of the approach controls are used to overcome gusts or changes in static conditions, care being taken to observe principles of reverse control should the speed fall below reversing speed or should the airship be placed in danger by loss of static lift.

g. When the airship arrives within 50 to 200 yards of the landing party it is brought to landing height. This depends on type of airship and length of handling guys used. Large nonrigids usually land about 60 feet off the ground, rigids at a much higher altitude, while the motorized observation balloon must be landed at an altitude of 25 feet or less. In this connection it should be borne in mind that the lower a statically heavy landing can be made the smaller the drop after aerodynamic control ceases. In that case, also, care should be taken to level the airship by use of elevators as it falls into the hands of the party, as otherwise the tail would be injured.

h. The landing described above is the usual type of landing. The description is not at all complete since it omits nearly all the static principles involved. The other types of landings, such as turn landings, will not be discussed, since the dynamic principles involved therein are similar to those already explained.

SECTION VI

AERODYNAMIC STRESS

	Paragraph
Assumption as to condition of maximum stress-----	38
Transverse forces acting on airship flying at constant angle of pitch-----	39
Transverse forces acting on airship in steady turn-----	40
Forces caused by gusts-----	41
Empirical formulas for maximum aerodynamic bending moment on hull and for forces on tail surfaces-----	42
Method of calculating shear and bending moment on hull-----	43
Conclusion-----	44

38. Assumption as to condition of maximum stress.—*a.* For airships designed prior to the World War the air speeds were quite slow. The aerodynamic forces acting on these airships were conse-

quently insufficient to give shear or bending moments large enough to endanger an airship designed to care for the static loading. At present the speed of airships has been so materially increased that aerodynamic forces, which vary as the square of the speed, must be considered. While it is not the function of this manual to teach design of airships, a general knowledge of results of these forces and moments is sufficiently important to the pilot to warrant inclusion herein a simplified discussion thereof.

b. As previously stated, the longitudinal aerodynamic forces are usually not a source of danger to the airship. The single exception to this statement occurs in the case of the pressure airship flying at maximum or nearly maximum speed. At this time the nose pressure may attain such magnitude that it may very conceivably exceed the pressure for which the airship was designed, in which event the nose will cave in. Since it is the internal pressure of the gas which resists such caving action, it should be the duty of the pilot to increase his internal pressure to the maximum allowable pressure when flying at velocities approximating maximum design speed.

c. The most important aerodynamic stresses are those caused by transverse forces. In order to design for such stresses, it becomes necessary to make assumptions concerning conditions which give greatest transverse forces. It was early believed that the worst condition occurred at the instant of simultaneous application of full rudder and elevator control. This assumption would appear reasonable in view of the fact that momentarily inertia of the airship will arrest any tendency toward rotation, but as soon as an angular velocity is attained, rotation of the tail reduces the forces on the surfaces. However, this argument omits one important consideration. It frequently occurs that at the moment of application of the controls, the airship may be under the action of forces giving it yaw or pitch in a direction opposite to that desired. In this case while initial yaw or pitch is being overcome, the hull will be subjected to a twisting action caused by two opposing moments. Theoretical treatment of stresses so caused is quite complicated and many designers simply arbitrarily double the forces which arise when full rudder and elevator are applied simultaneously.

d. During the design of the *RS-1* airship various conditions of static loading, with a load factor of 4, were investigated. Stresses found in the keel members under static loading conditions were combined with stresses found under the following conditions of aerodynamic loading to determine maximum stress in any member. In arriving at low load factors applied to aerodynamic loading condi-

tions, the effect of the envelope in relieving the keel by resisting a portion of the shear and bending was neglected. It was found that this was very conservative as subsequent tests on water-filled models and full-scale tests on the *RS-1* airship indicate that the keel resists approximately 50 percent of total bending due to static loads. However, in flight tests it was found that the keel resists only 10 percent of the bending moment due to external air loads in pitch. In order to be conservative however in future designs of semirigid airships the design should be based on the assumption that the proportion of the total loads on the airship due to external air loads in pitch in flight resisted by the keel is half that found in the case of static weights and that a load factor of 2.0 be used.

- (1) Horizontal flight at 55 miles per hour with a load factor of 4.0.
- (2) Horizontal flight at 70 miles per hour with a load factor of 3.0.
- (3) Pitch up or down at an angle of $3^{\circ} 19'$ at 55 miles per hour with a load factor of 3.0.
- (4) Yaw at 55 miles per hour with load factor of 3.0.
- (5) Turning, 1,500 feet radius at 55 miles per hour with load factor of 2.0.
- (6) Mooring by the nose with pitch up, pitch down, and yaw of $4^{\circ} 0'$, in a gale of 70 miles per hour with a load factor of 2.0.

e. From the foregoing discussion it is evident that the pilot should be cognizant of maximum angles of pitch and yaw for which his aircraft was designed. Then when atmospheric conditions render it impossible to keep the airship within design limits he should reduce his air speed to effect a reduction of the aerodynamic forces.

f. To simplify the discussion transverse forces will be considered under three classes:

- (1) Transverse forces at fixed angle of pitch.
- (2) Transverse forces in steady turn.
- (3) Forces caused by gusts.

39. Transverse forces acting on airship flying at constant angle of pitch.—*a.* When an airship is flying at a constant positive angle of pitch it is acted on by the following dynamic transverse forces:

- (1) Component normal to longitudinal axis of dynamic force on tail surfaces.
- (2) Component normal to longitudinal axis of dynamic force on hull.

Since rotation is considered about the center of buoyancy it is necessary to divide the latter force into two parts. This is essential because the normal force on the forebody is directed upward, whereas the normal force on the afterbody is directed downward. It has been

shown by a member of the National Advisory Committee for Aeronautics that the algebraic sum of the forces on the fore and after bodies is theoretically zero, which would indicate that the dynamic lift on the hull was zero, and that the total lift obtained dynamically by the airship, exclusive of the vertical component of the propeller thrust, was that furnished by the surfaces. This is not in strict agreement with the actual facts, since the down thrust on the afterbody is less than the theoretical down thrust. However, the fact remains that, since the pitch remains constant, the sum of the moments about the center of buoyancy must equal zero.

b. The turning moment of the aerodynamic forces on the hull theoretically equals the formula:

$$(\text{Vol}) \frac{\rho}{2} v^2 (k_2 - k_1) \sin 2\theta$$

where θ = angle of pitch.

k_2 and k_1 = constants correcting for additional masses of air carried longitudinally and transversely. Values of k_1 and k_2 are given in National Advisory Committee for Aeronautics Report No. 184.

c. If it is granted that the dynamic force on the tail equals the total resultant static transverse force, its moment must equal the formula given in *b* above. Hence—

$$Fa = (\text{Vol}) \frac{\rho}{2} v^2 (k_2 - k_1) \sin 2\theta$$

where F = component of force on tail surface normal to longitudinal axis.

a = distance from center of buoyancy to center of pressure of tail surface.

The above formula will give an approximation of dynamic lift of the airship.

d. Practically, F need not be as large as indicated above due to the discrepancy between actual and theoretical values of the down thrust on the afterbody. The point of application of F is slightly forward of the center of the area of the tail surfaces.

e. For method of calculation of shear bending moments due to dynamic forces see paragraph 43.

40. Transverse forces acting on airship in steady turn.—The theory in this case is quite similar to that described in paragraph 39. Assuming, as before, that the algebraic sum of the forces on the fore and after portions of the airship hull equals zero, the other two forces acting on the airship (the force on the fins and centrifugal force) must

be equal to produce motion in a constant turn. From this is derived the relation—

$$\sin 2 \Psi = \frac{2a}{R(k_2 - k_1)}$$

where Ψ = angle of yaw.

a = distance from center of volume to center of pressure of tail surfaces.

R = radius of turning circle.

This relation gives results widely at variance from the results of actual tests on full-sized airships, presumably due to the assumption that the resultant of the hull forces is zero. Fortunately, the total bending moment due to a steady angle of turn is only about one-fifth as great as that due to an equal fixed angle of pitch where unbalanced weight and centrifugal force are of equal magnitude.

41. Forces caused by gusts.—*a.* Very little is known concerning maximum value of forces caused by gusts. The following statement very excellently sums up the situation:

¹ "The existence of veritable fountains of upward rushing air whose sides at times and places are sharply separated from the surrounding atmosphere must be taken into account in the design of airships. The most violent of such currents, the tornado, combines vertical velocity with rotation, but fortunately can be seen from a great distance, and can and must be avoided. The thunderstorm with large fully developed cumulus tops is also conspicuous and avoidable. It would appear to be folly to enter such a cloud and subject the ship to the unknown dangers of wind, rain, hail, and lightning. Barring such spectacular hazards, there remain convection currents which the ship may run into at full speed. There is ample evidence that upward velocities as high as 10 feet per second may be encountered. This vertical air velocity u , combined with the relative horizontal speed v of the airship, will give

the effect of a change of pitch of $\tan^{-1} \frac{u}{v}$."

b. It remains simply for the pilot, as stated in paragraph 38*e*, to reduce the speed in bumpy atmosphere, especially if at the same time the airship is developing large dynamic lift, positive or negative, as then the stresses are already large.

42. Empirical formulas for maximum aerodynamic bending moment on hull and for forces on tail surfaces.—*a.* The following formula has been developed for the maximum aerodynamic bend-

¹ From "Airship Design" by C. P. Burgess by permission of the Ronald Press.

ing moment to be expected from such bumpy weather as would be encountered in mountainous country:

$$M_b = 0.005 \rho v^2 (\text{vol})^{2/3} L$$

where M_b = the maximum bending moment in foot-pounds,

L = the length of the airship in feet.

Use of this formula enables the pilot to calculate rapidly maximum stresses to which his velocity in bumpy air may be subjecting his airship.

b. Where surfaces are designed in approximate accordance with the formula $A = 0.13 (\text{vol})^{2/3}$, the total transverse force on either vertical or horizontal surfaces may be computed quickly by the relation:

$$F = 0.026 (\text{vol})^{2/3} \rho v^2.$$

In above formulas

A = total area of either surface.

F = total force on either surface.

43. Method of calculating shear and bending moment on hull.—*a.* The designer and also the pilot in determining shear and bending moments on the airship must consider both static and dynamic loads. Both must be computed independently and then added together algebraically. It often happens that dynamic loads serve to reduce stresses due to static loading, but naturally the dangerous case occurs when stresses are arithmetically additive.

b. The method to be described applies more particularly to rigid airships, but the principle can be applied to a nonrigid. In the latter case, the load instead of being distributed throughout the length of the hull is swung from the envelope by suspension cables which by their tensions control very largely distribution of loading on the envelope.

c. For calculation of stresses, the hull is considered as a beam loaded with the weights acting downward, lift of gas cells acting upward and aerodynamic forces acting in any longitudinal plane whatsoever. All loads are considered as concentrated at the frames rather than as uniformly distributed. The calculations may be divided into steps, as follows:

- (1) Calculation of static load.
- (2) Calculation of shear due to static loading.
- (3) Calculation of bending moment due to static loading.
- (4) Calculation of load, shear, and bending moments due to aerodynamic forces.
- (5) Algebraic summation of effects of static and dynamic loading.

d. The initial step in the computation is determination of distribution of weights. This is taken from the detailed weight statement, weights therefrom being distributed to the proper frames. Lift of the gas in each cell is computed next and distributed as concentrated forces on the frames. The static loads on the hull are the differences between weight and buoyancy at each frame, lift being considered

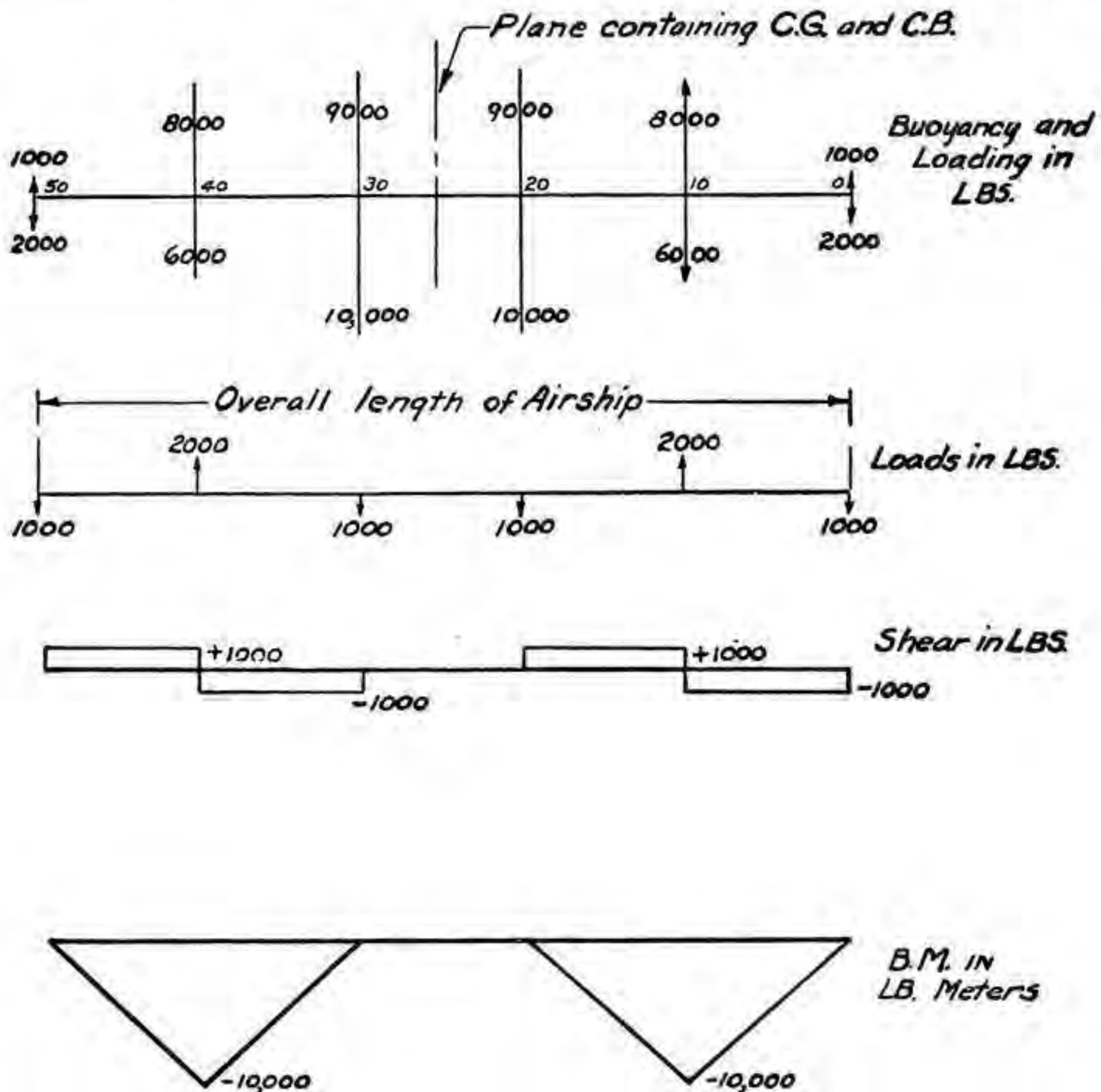

FIGURE 27.—Loads, shear, and bending moments caused by static loading.

positive and loads negative. When the airship is in static equilibrium, the algebraic sum of the loads must equal zero. Figure 27 illustrates the computation of loads at each frame of an airship 50 meters long, having four frames spaced 10 meters apart. The method shown is applied to the largest airships.

e. Commencing at either end of the airship, the shear at any frame equals the algebraic sum of loads up to that frame. This system gives a constant shear between frames, changing at each frame by

the amount of load at that frame. The shear in figure 27 was computed in this manner.

(1) For instance, the load at station 0 is $-1,000$ pounds. Then the shear between stations 0 and 10 equals $-1,000$ pounds. At station 10 the load is $+2,000$ pounds. Hence the shear between stations 10 and 20 is $-1,000$ pounds $+2,000$ pounds, or $+1,000$ pounds.

(2) For an airship in static equilibrium, when centers of buoyancy and gravity are vertically disposed, areas under the shear curve must add algebraically to zero. This should be checked before proceeding to computation of bending moments.

f. For calculation of bending moments, all loads between ends of the airship and any frame are considered as supported by cantilever action from that frame. In the case illustrated by figure 27 starting at station 0, the bending moment for—

(1) Station 0 = 0.

(2) Station 10 = $-1,000 \times 10 = -10,000$ meter-pounds.

(3) Station 20 = $(-1,000 \times 20) + (2,000 \times 10) = 0$.

g. An easier method of computing bending moments is to sum up the areas under the shear curve. Thus in figure 27, for station 20, the bending moment = $10,000 - 10,000 = 0$. For an airship in static equilibrium, when the center of gravity is vertically below the center of buoyancy, the bending moment curve returns to zero at both ends of the airship, since the summations of positive and negative areas under the shear curve are numerically equal.

h. Table IV, extracted from "Airship Design," by C. P. Burgess, of the Bureau of Aeronautics, United States Navy, shows loads, shear, and bending moments on the *ZR-1*, computed in accordance with the method described therein.

i. In computing aerodynamic loads, shear, and bending moments, a method somewhat similar to that described above is employed.

(1) Upturning dynamic forces on the hull are computed, using the Munk formula. This formula is omitted here as it involves mathematical computation beyond the scope of this manual. The forces so determined are distributed to the frames as concentrated loads.

(2) Excess static weight or buoyancy is then distributed to the frames in proportion to the cross-sectional area at the frames, unless known eccentric loading shows this distribution to be greatly in error.

(3) Dynamic force on surfaces is then distributed to proper frames. This force, as shown in paragraph 39*c*, is given by the relation—

$$F = (\text{Vol}) v^2 \frac{\rho}{2a} (k_2 - k_1) \sin 2\theta$$

TABLE IV.—*Loads, shear, and bending moments in U. S. S. ZR-1 when the gross lift is 136,634 pounds*

[This table reproduced from Airship Design, by C. P. Burgess, by permission of the Ronald Press]

Station meters	Gross lift	Fixed weight	Dispos-able weight	Total weight	Load	Shear	Bending moment m.
	<i>Pounds</i>	<i>Pounds</i>	<i>Pounds</i>	<i>Pounds</i>	<i>Pounds</i>	<i>Pounds</i>	<i>Pounds</i>
0-----	307	2, 618	0	2, 618	-2, 311	-2, 311	
10-----	1, 453	1, 877	0	1, 877	-424	-2, 735	-23, 110
20-----	2, 812	1, 902	0	1, 902	910	-1, 825	-50, 460
30-----	4, 496	1, 991	2, 276	4, 267	229	-1, 596	-68, 710
40-----	5, 789	2, 328	2, 200	4, 528	1, 261	-335	-84, 670
50-----	7, 128	2, 389	5, 182	7, 571	-443	-778	-88, 020
60-----	8, 218	5, 858	1, 512	7, 370	848	70	-95, 800
70-----	8, 985	2, 708	2, 378	5, 086	3, 899	3, 969	-95, 100
80-----	9, 402	3, 091	5, 656	8, 747	655	4, 624	-55, 410
90-----	9, 510	9, 483	6, 100	15, 583	-6, 073	-1, 449	-9, 170
100-----	9, 540	3, 224	6, 055	9, 279	261	-1, 188	-24, 660
110-----	9, 584	3, 069	5, 704	8, 773	811	-377	-36, 540
120-----	9, 560	8, 183	5, 016	13, 199	-3, 639	-4, 016	-40, 310
130-----	9, 536	3, 096	1, 790	4, 886	4, 650	634	-80, 470
140-----	9, 417	3, 064	5, 562	8, 626	791	1, 425	-74, 130
150-----	9, 003	2, 712	5, 406	8, 118	885	2, 310	-59, 880
160-----	8, 169	8, 057	2, 259	10, 316	-2, 147	168	-36, 780
170-----	6, 778	3, 076	2, 653	5, 729	1, 049	1, 212	-35, 150
180-----	4, 467	3, 212	1, 227	4, 439	28	1, 240	-23, 030
188-----	2, 222	1, 520	0	1, 520	702	1, 942	-13, 110
194.75-----	258	1, 100	1, 100	2, 200	-1, 942		0
	136, 634	74, 558	62, 076	136, 634	0000		

(4) The load on each frame, shearing forces, and bending moments are then computed and tabulated as explained in *d*, *e*, *f*, *g*, and *h* above. A table so prepared, extracted from Airship Design, is given below.

TABLE V.—*Aerodynamic forces, shear, and bending moments in U. S. S. ZR-1 at 85 foot/seconds and 5° 42' pitch*

Station meters	Turning forces on hull	Unbalanced static weights	<i>L</i>	Load	Shear	Bending moment in pounds
			<i>Pounds</i>		<i>Pounds</i>	
0.....	-820	-57		-877		0
10.....	-1,032	-179	2,300	1,089	-877	-8,770
20.....	-1,200	-334	2,300	766	212	-6,650
30.....	-1,228	-500	3,754	2,026	978	3,130
40.....	-1,180	-665	4,937	3,092	3,004	33,170
50.....	-985	-816	2,300	499	6,096	94,130
60.....	-755	-933		-1,688	6,595	160,080
70.....	-494	-1,020		-1,514	4,907	209,150
80.....	-151	-1,067		-1,218	3,393	243,080
90.....	-55	-1,077		-1,132	2,175	264,830
100.....	0	-1,077		-1,077	1,043	275,260
110.....	0	-1,077		-1,077	-34	274,920
120.....	0	-1,077		-1,077	-1,111	263,810
130.....	41	-1,077		-1,036	-2,188	241,930
140.....	151	-1,067		-916	-3,224	209,690
150.....	494	-1,030		-536	-4,140	168,290
160.....	851	-933		-82	-4,676	121,530
170.....	1,346	-783		563	-4,758	73,950
180.....	1,891	-563		1,328	-4,195	32,000
188.....	1,780	-250		1,530	-2,867	9,020
194.75.....	1,346	-9		1,337	-1,337	0
		-15,591	15,591	000		

j. To determine total shear or bending moment at any frame, it is necessary to add results obtained from static loading to those computed from aerodynamic forces.

(1) To obtain total shearing force between stations 30 and 40:

	<i>Pounds</i>
Shear due to aerodynamic forces from table V	= 3,004
Shear due to static loading from table IV	= -1,596
Total shearing force	= <u>1,408</u>

(2) To obtain total shearing force between stations 80 to 90:

	<i>Pounds</i>
Shear due to static loading	= 4,624
Shear due to aerodynamic forces	= 2,175
Total shearing force	= <u>6,799</u>

(3) To obtain total bending moment at station 130:

	<i>Meter pounds</i>
Bending moment due to static loading from table IV	= -80,470
Bending moment due to aerodynamic forces from table V	= 241,930
Total bending moment	= <u>161,460</u>

44. Conclusion.—While static means of sustentation and control are available to lighter than air aircraft, the intelligent pilot should constantly bear in mind the effects of aerodynamic forces on his airship. He must understand the relation of velocity to resistance, power requirements, and fuel consumption. He must be cognizant of the characteristics of his propellers and be able to make utmost use of variable pitch should his propellers be capable of adjustment in that regard. He should comprehend the theory of airship stability and be alert to augment that stability by use of his controls. It is essential that he at all times appreciate effect of dynamic forces on his flight path in regard to both direction and altitude, and be able to assist his static control by dynamic means whenever necessary. Finally, he must be aware of the stresses to which his airship is being subjected and, knowing maximum performance for which his aircraft was designed, so vary the velocity as to preclude possibility of excess structural stresses.

[A. G. 062.11 (9-11-40).]

BY ORDER OF THE SECRETARY OF WAR:

G. C. MARSHALL,
Chief of Staff.

OFFICIAL:

E. S. ADAMS,
Major General,
The Adjutant General.

DISTRIBUTION:

D 1 (3); B 1 (2); IR 1 (5); IBn 1 (10).

