



U.S. Department
of Transportation
**Federal Aviation
Administration**

Advisory Circular

**Subject: INSTALLATION, INSPECTION, AND
MAINTENANCE OF CONTROLS FOR
GENERAL AVIATION RECIPROCATING
AIRCRAFT ENGINES**

**Date: 6/06/00
Initiated By: ACE-100**

**AC No: 20-143
Change:**

1. PURPOSE. A review of service history on engine control installations indicates that a significant percentage of the problems are related to maintenance. Of the control system problems related to maintenance, approximately 75 percent of the problems with these systems result from lack of proper maintenance of airplane manufacturer installed engine controls. The other 25 percent of the service problems originate from a lack of maintenance of the engine manufacturers' throttle, mixture, and propeller governor levers/linkages. Most airplane or engine maintenance manuals lack detailed information on inspection and installation of engine controls. Therefore, this advisory circular (AC) presents information regarding the inspection, maintenance, and installation of engine controls with emphasis on the airframe portion of these systems. It provides guidance to design and maintenance personnel to reduce the number of airplane accidents and incidents related to the loss of engine power control. This material is neither mandatory nor regulatory in nature and does not constitute a regulation. This AC is provided to supplement, but not replace the procedures in the manufacturers' maintenance manuals. Where the content of this AC differs from, or conflicts with, the manufacturer's maintenance manual, instructions contained in the manufacturer's manual take precedence over the guidelines provided in this AC.

2. RELATED REGULATIONS. Title 14 Code of Federal Regulations (14 CFR) Part 21, § 21.50. Airplane airworthiness regulations are specified in 14 CFR Part 23, §§ 23.1141, 23.1143, 23.1147, 23.1149, and 23.1529, and the corresponding Civil Air Regulations (CAR) under Part 3. Engine airworthiness regulations are specified in 14 CFR Part 33, §§ 33.4, 33.15 and 33.19, and their corresponding CAR under Part 13. Propeller airworthiness regulations are specified in 14 CFR Part 35, § 35.4, and the corresponding CAR under Part 14. Inspection requirements can be found in 14 CFR Part 43, appendix D, and § 43.15(c).

3. BACKGROUND. Current 14 CFR design rules require throttle and mixture controls on single reciprocating engine-powered airplanes that will allow continued safe flight and landing in the event of a control separation at the engine fuel metering device. The current rules (§§ 23.1143(g) and 23.1147(b)) are not applicable to older airplanes. This AC has been prepared to address proper

installation, inspection, and maintenance of many different types of engine controls on airplanes old and new regardless of the rules under which they were certified. General requirements are contained in Part 43, appendix D, which specify the scope and detail of items to be included in annual and 100-hour inspections, of which paragraph (d)(6) states, "Engine controls—for defects, improper travel, and improper safetying." This AC will provide expanded guidance for general aviation airplanes equipped with reciprocating engines.

4. DEFINITIONS.

- a. **Rod End.** A machined fitting on one end of a control cable or rod, which is usually threaded on one end and has a hollow ball and socket at the other end, that allows a swivel motion at the engine lever attachment (see figure 1).

FIGURE 1. LINKAGE CONNECTION TO ENGINE

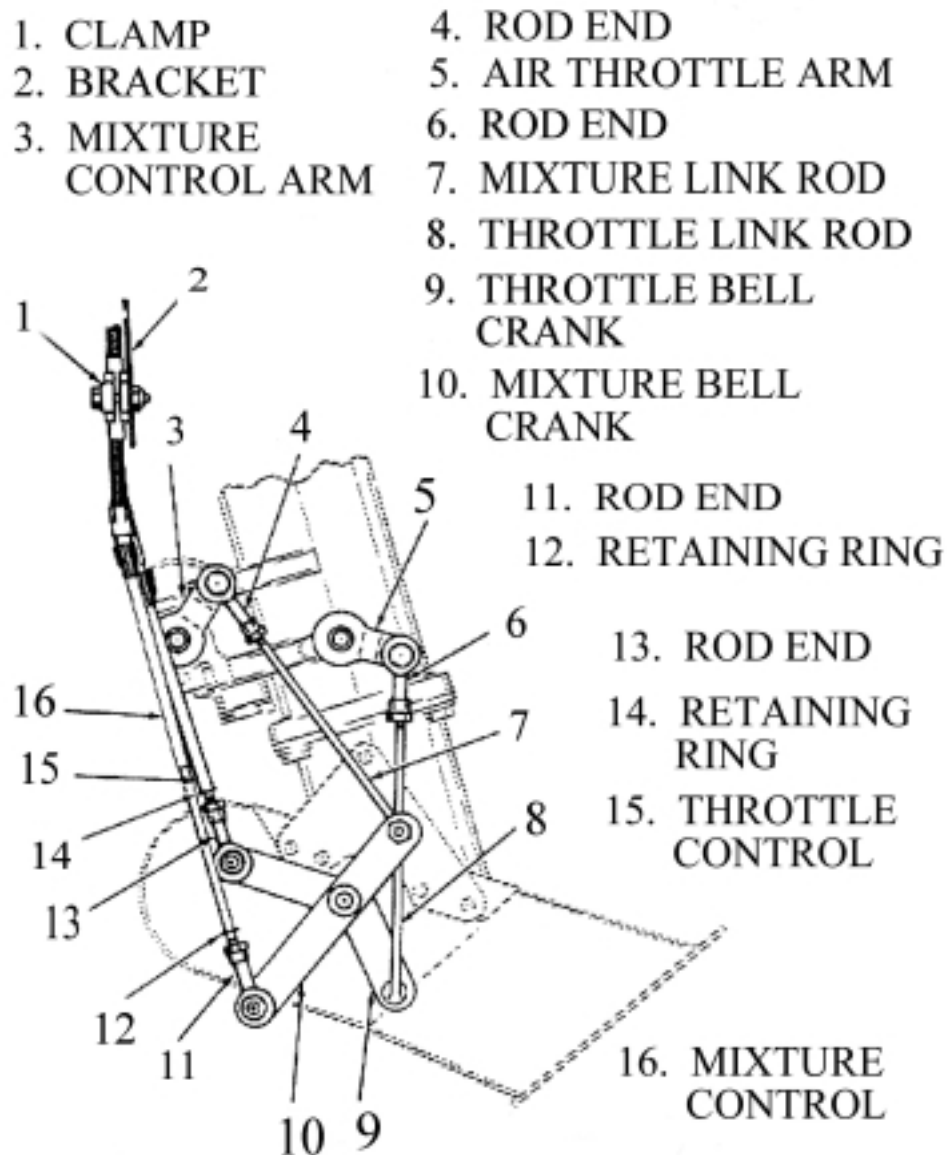

NOTE: For guidance information only. May not represent actual installations.

- b. **Secondary Retainment Washer.** A large load-bearing washer adjacent to the outside face of rod end fitting (see figure 2).

FIGURE 2. ROD END SAFETY PROCEDURE USING SECONDARY WASHER RETAINMENT

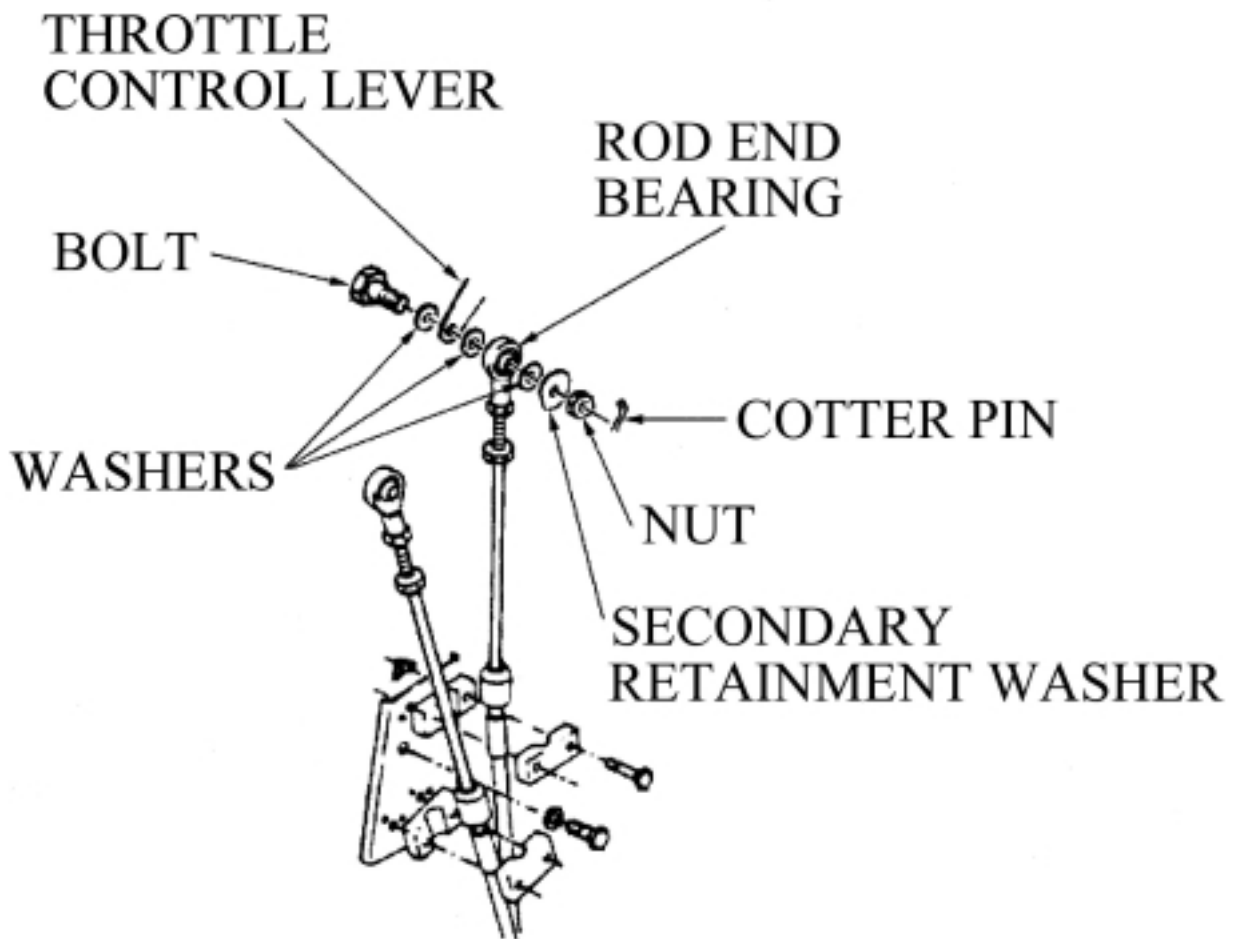

NOTE: For guidance information only. May not represent actual installations.

- c. **Swaged Joint.** A connection of a cable end to a rigid rod or tube (usually by staking or crimping) that transmits cable motion to the engine control lever.
 - d. **Alternate Air Control.** A flexible or rigid control attached to a small door at the carburetor air inlet, or fuel-injector throttle body, that allows entry of heated air or sheltered compartment air.
 - e. **Fire Sleeve.** A protective sleeve covering (e.g., steel, aluminum, asbestos) added to a control cable or rod end connection that provides local heat or fire protection.
5. **INSPECTION PROCEDURE - GENERAL.** The need for the correct installation of the engine control cable, attaching hardware, and fuel system component levers and linkages cannot be overemphasized. The use of approved attachment procedures and techniques is required to assure proper operation and to prevent accelerated wear.

CAUTION

Replacement of rotatable powerplant controls capable of knob rotation at the instrument panel with non-rotatable solid shaft controls is discouraged. Solid shaft controls (non-rotatable at the instrument panel knob) have been found disconnected at the rod end as a result of pilots attempting to adjust a friction lock without realizing that the knob was also being rotated. Solid shaft powerplant controls may be replaced with rotatable knob controls when acceptable data exists.

- a. In the absence of specific inspection intervals, repetitive inspections of the engine controls in the nacelle and cockpit areas should be conducted as part of the annual and 100-hour inspections described in Part 43, appendix D.
- b. Inspect all engine control cables for proper tension, routing, security, and signs of damage caused by chafing and heat distress. Improper installation of cables will significantly reduce their service life.
- c. In addition to the throttle and mixture controls, inspect the operation of each engine-related control such as the propeller, carburetor heat, alternate air, and cowl flap controls as applicable. Make certain that each control has full limit of travel, and that no binding or excessive play caused by worn parts or improper installation is evident.
- d. Apply simulated air loads by manually pressing on cowl flaps and alternate air controls to ensure cables are not slipping in support clamps. Check for looseness of throttle, mixture, and propeller controls to ensure proper security of these components.
- e. Replace all control cables, levers, link rods, and attaching hardware found damaged or worn beyond acceptable service limits. Engine-related levers, link rods, and attaching hardware should be installed in accordance with the instructions provided in the applicable aircraft or engine maintenance manuals. Consult the airframe/engine manufacturer's published

instructions for routing and attachment of the various engine-related control cables. Attachment of components that have relative motion should be accomplished by using bolts (screws) drilled for cotter pins, using castellated nuts, cotter pins, and large secondary washer retention devices. (See figures 1, 2, and 3.)

WARNING:

Connections requiring torque fasteners should not exhibit any relative movement or motion between components.

FIGURE 3. CABLE RETENTION METHOD

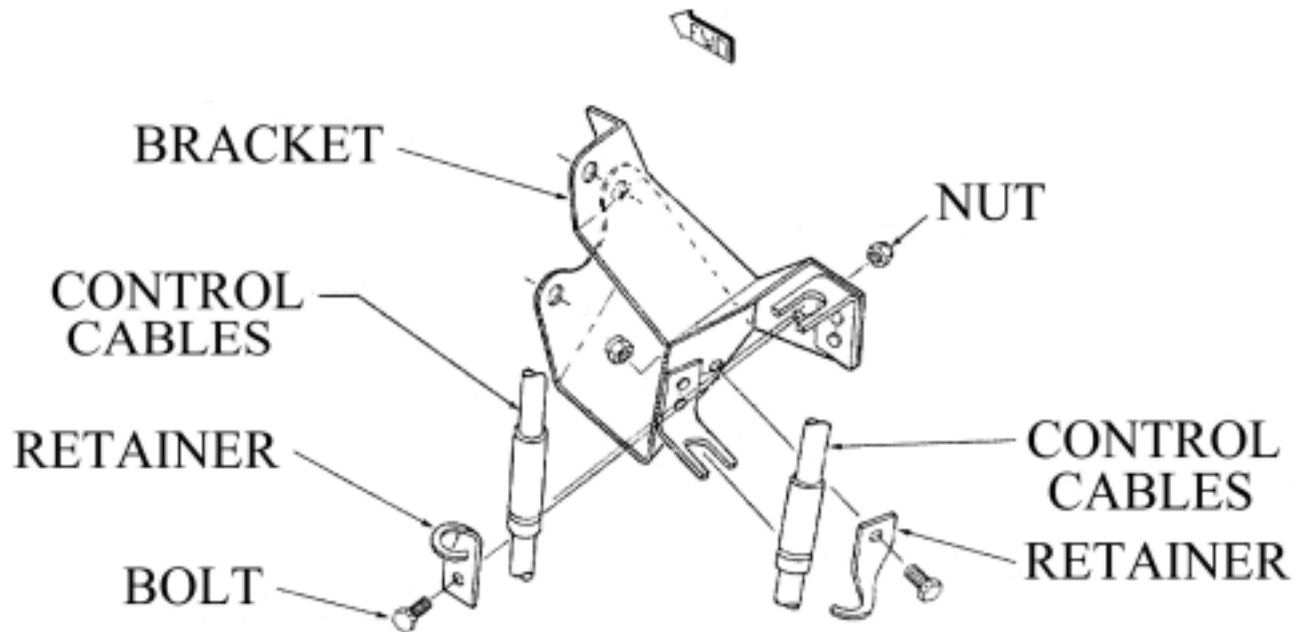

NOTE: For guidance information only. May not represent actual installations.

6. LUBRICATION OF CONTROL RODS, LINKAGES, AND JOINTS (see figures 4 and 5). Damage and wear to the actuating components of engine control systems can be attributed to improper (or the lack of) lubrication. During scheduled and unscheduled maintenance, engines are normally cleaned using a solvent or soap solution pressure wash. This tends to remove lubrication from fuel system levers, linkages, and bushings. Therefore, it is necessary that these areas be lubricated after engine cleaning and during scheduled maintenance as indicated in the following paragraphs:

- a. Consult with the airplane and engine manufacturers, plus the control cable manufacturer if necessary, for published instructions covering powerplant control cable service-life limits and attach-point inspection, repair, installation, and lubrication.
- b. Inspect the pivot points of the levers and linkages for dirt, wear, and rust, and replace as necessary. Direct cleaning of these areas may be necessary to remove contamination including a buildup of old grease or oil. After cleaning with clean solvent or soap solution, dry each area using compressed air.

FIGURE 4. SOLID ROD LINKAGE LUBRICATION

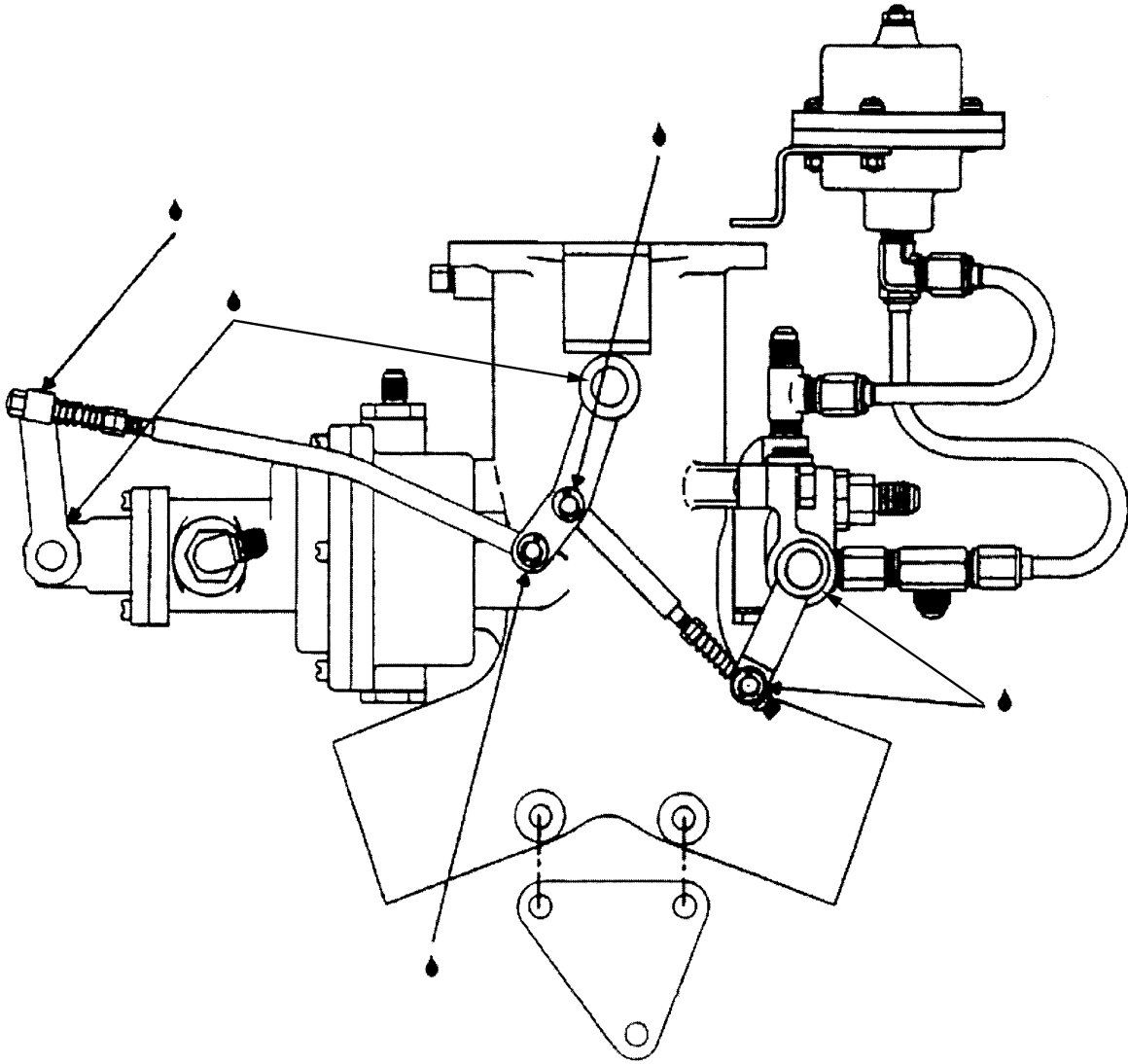

NOTE: For guidance information only. May not represent actual installations.

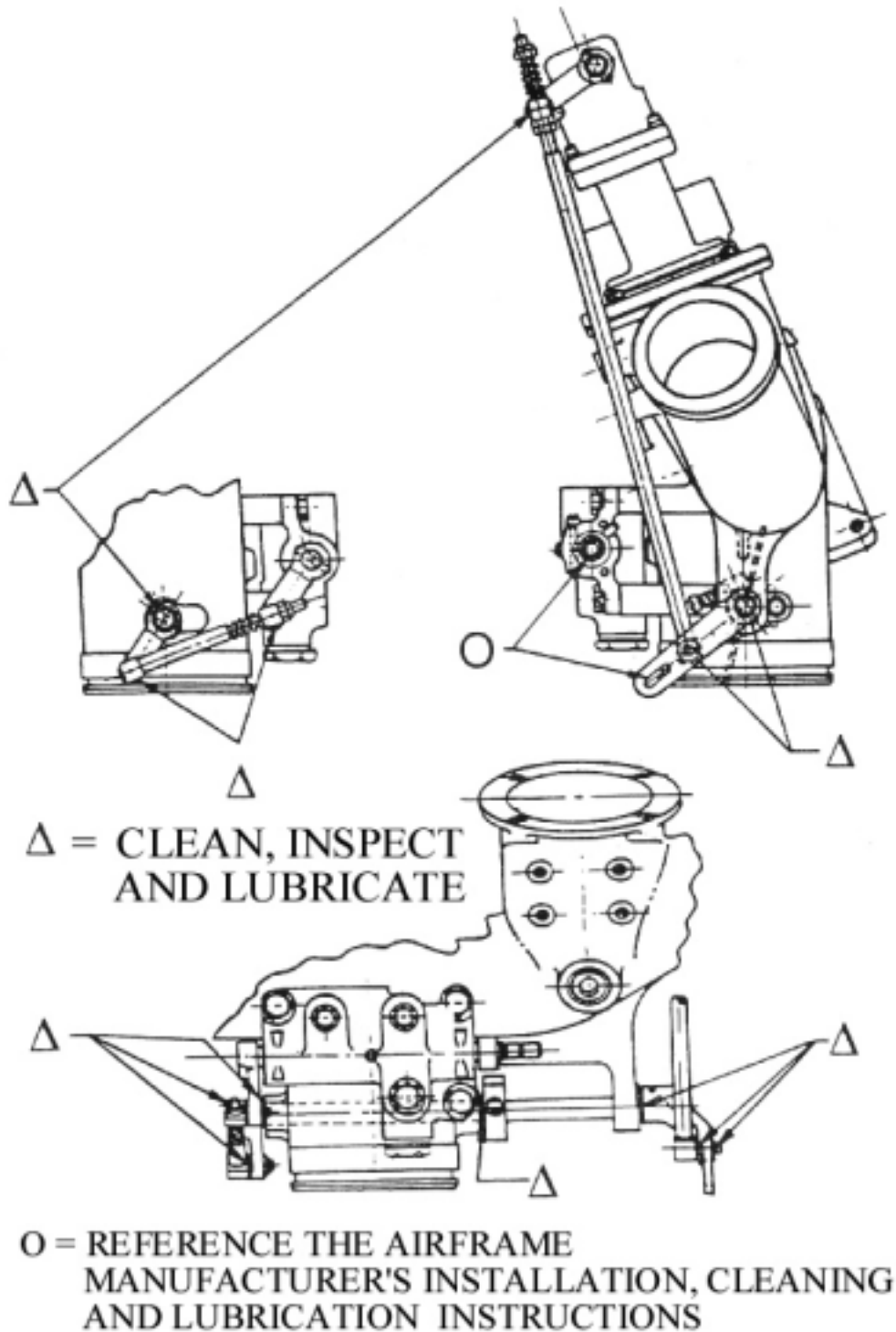
FIGURE 5. SOLID ROD ADJUSTMENT AND LUBRICATION

NOTE: For guidance information only. May not represent actual installations.

- c. Lubrication of control cables (including pressure lubrication) should not be attempted without a specific approved procedure. Engine controls without an approved procedure should be permanently tagged. Pressure lubrication should not be performed on any control without an approved procedure. Contact the airframe or engine manufacturer for additional guidance.
- d. Use proper tools and holding devices when installing, adjusting, or removing controls and fittings. Avoid using tongue and groove pliers or locking grip pliers. Failure to use the proper tools may result in crushed or bent engine control components.
- e. In the absence of specific lubrication information from the manufacturer, it is acceptable to apply LPS 2®, Permatex “Maintain®” Lubricant, or equivalent, to each pivot point, including throttle shaft bushings. If parts such as a lever or link rod are to be replaced or reassembled, initial lubrication may be accomplished by using Shell Number 5 grease, or LUBRIPLATE®, Number 630AA, or equivalent.

NOTE. These lubricants function well in cold weather. However, airplanes operating in extremely cold conditions may be better off with little or no lubricant on the control levers, linkages, and bushings.

7. **RIGGING PRACTICES** (see figure 6). A typical rigging check procedure is as follows:

FIGURE 6. ROD END FITTING WITH PROTECTIVE SLEEVE AND THREAD ENGAGEMENT

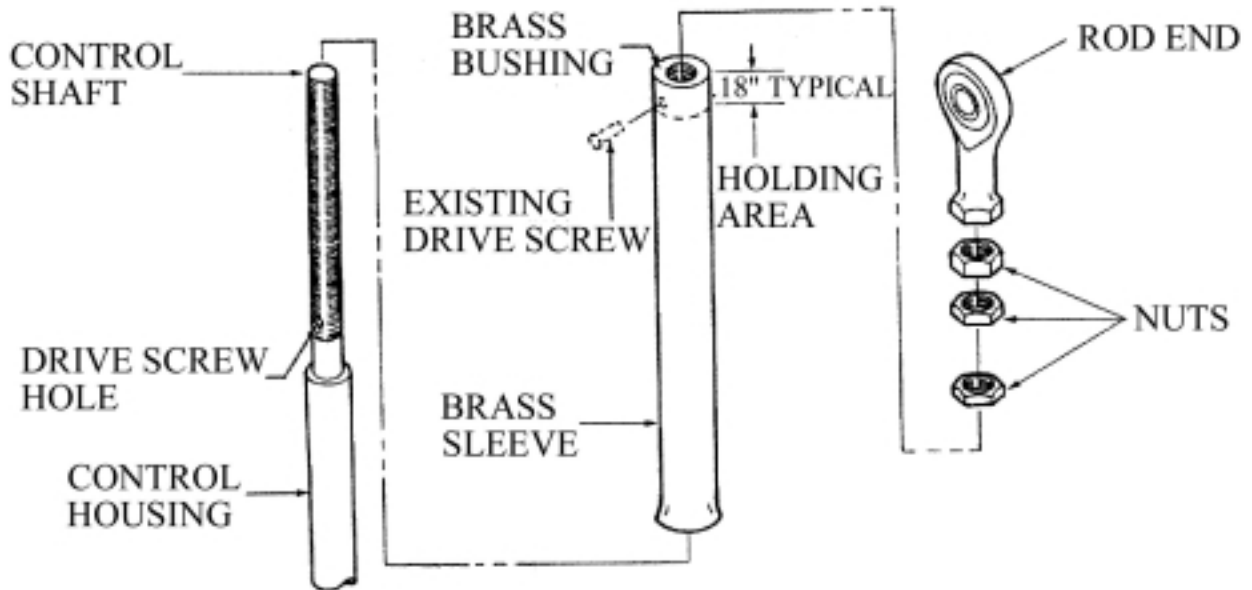

NOTE: For guidance information only. May not represent actual installations.

- a. The appropriate airplane and engine manuals, and service bulletins, should be consulted for each installation.
- b. Examine the alignment of the accessory end (engine end) of the control, ensuring that the accessory unit operating arm does not cause binding or bending of the control cable, push rod, or swivel fitting.
- c. Ensure that there is freedom of movement of rod-end fittings and clevis-fork fittings throughout their entire range of travel.
- d. Ensure that any threaded shank has at least the minimum required thread engagement.
- e. Rig engine controls in a manner leaving 1/16- to 1/8-inch of unused travel in the full throttle, full rich, or maximum r.p.m. position. This is achieved by having the accessory unit control arm against its travel stop, while the engine control knob in the cockpit has 1/16- to 1/8-inch margin before contacting its stop.

8. INSTALLATION VERIFICATION. After proper installation, lubrication, and rigging have been accomplished, the following should be verified:

- a. Each control should be able to maintain any necessary position without constant attention by the pilot or without tendency to creep due to control loads, or vibration (see § 23.1141(c)).
- b. Each control should permit full limit of travel and have the required safety or locking device in place. There should be no binding of levers, linkages, control rods, or cables. There should be freedom of movement unrestricted by contact with other parts or components that are located in close proximity.
- c. Verify that separation between engine controls and exhaust system components is consistent with the manufacturer's guidelines, or are secured as far away from each other as possible. Ensure that heat shields are installed in accordance with the manufacturer's instructions.
- d. Check fuel system flow (after mixture control, shutoff valve, or selector valve linkage installation) and adjust, as required, in accordance with the engine/airplane manufacturers' applicable maintenance manual or service bulletin instructions.

9. Appendix 1 provides supplemental illustrations for inspection, maintenance, and installation of engine lever and cable controls. These figures are for guidance only and may not represent actual installations.

S/ Marvin Nuss for

Michael Gallagher
Manager, Small Airplane Directorate
Aircraft Certification Service

APPENDIX 1 SUPPLEMENTAL ILLUSTRATIONS

FIGURE 1. INSTRUMENT PANEL CONTROL CONFIGURATION

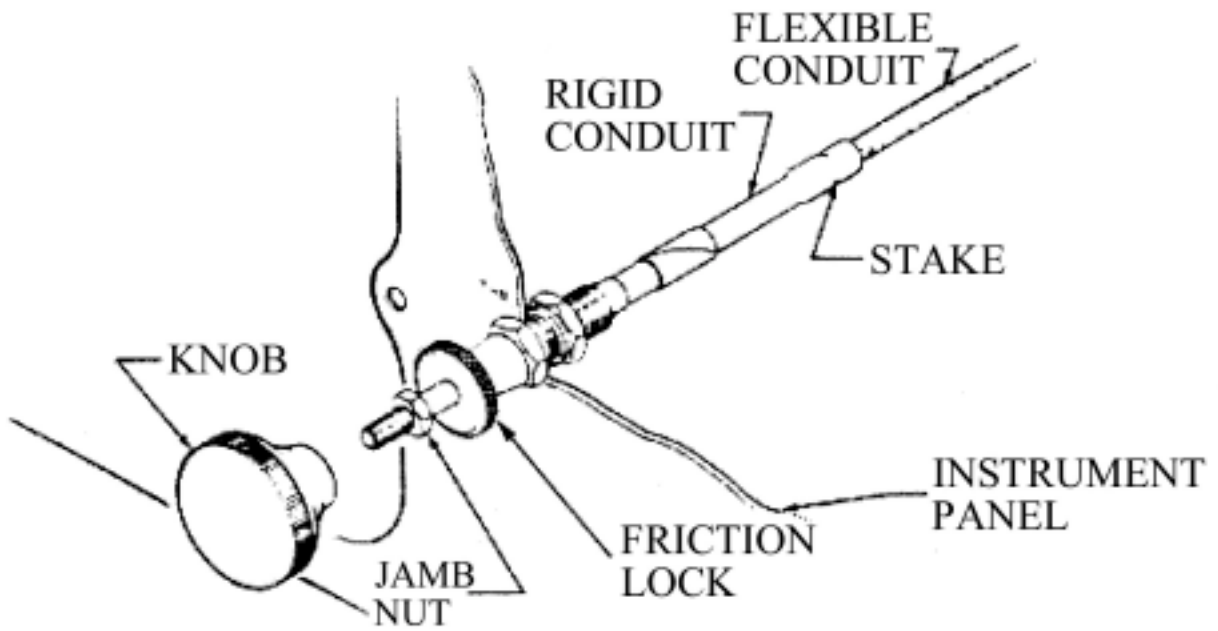

NOTE: For guidance information only. May not represent actual installations.

FIGURE 2. SWIVEL (SWAGED) BALL JOINT INSPECTION CONFIGURATION

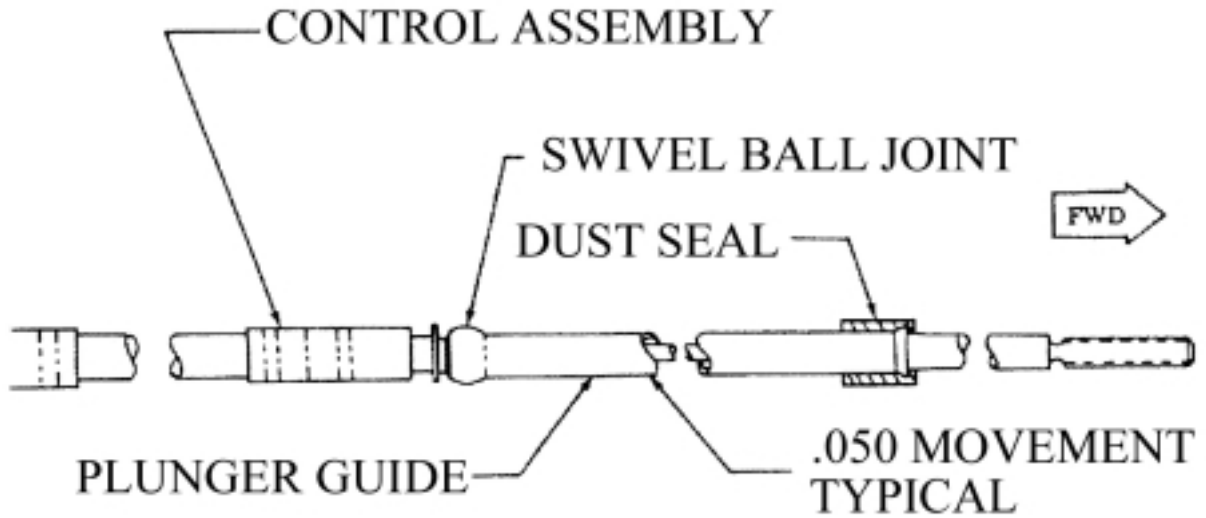

NOTE: For guidance information only. May not represent actual installations.

FIGURE 3. CONTROL CABLE ROUTING FROM HIGH HEAT SOURCES

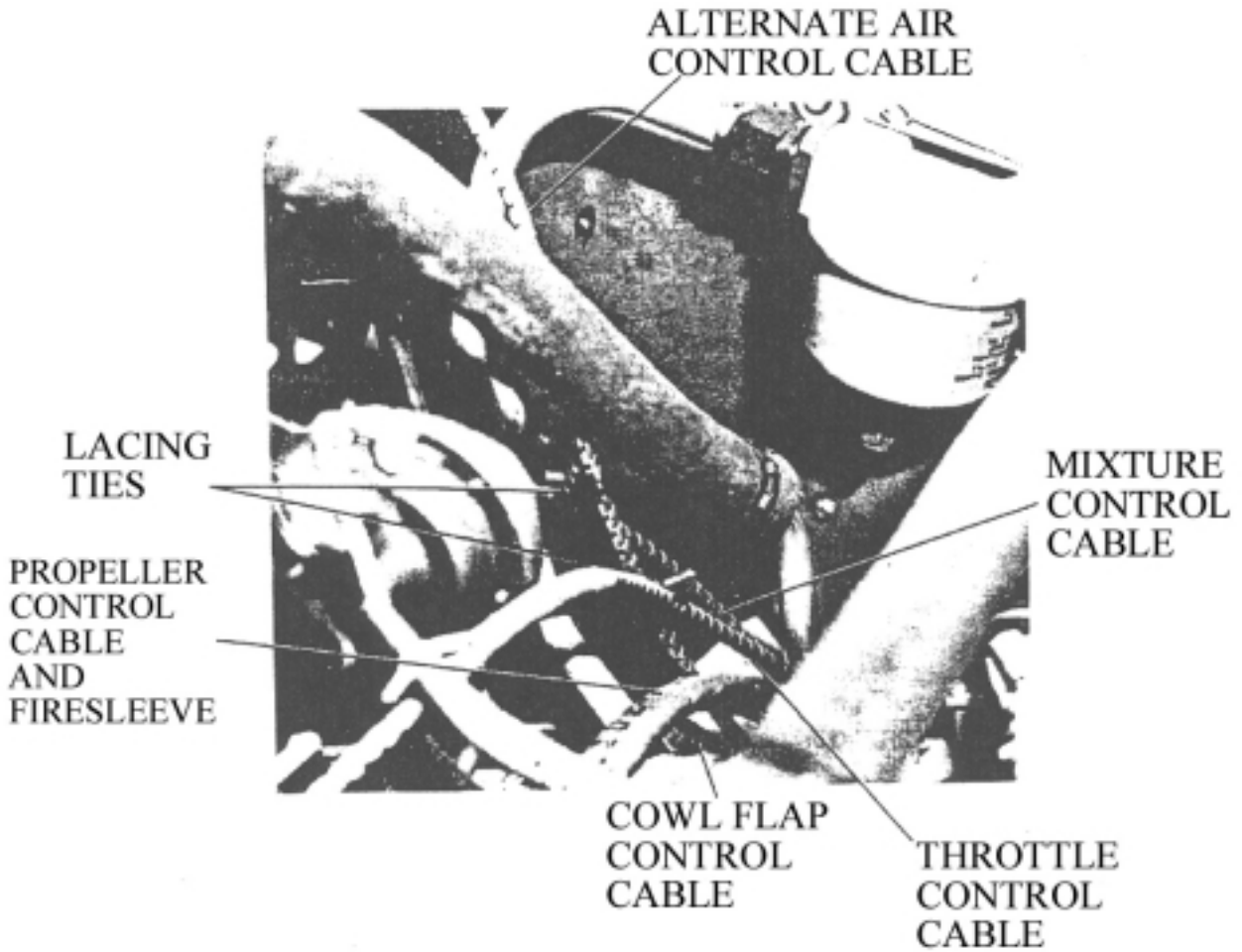

NOTE: For guidance information only. May not represent actual installations.

FIGURE 4. CONTROL CABLE ROUTING FROM HIGH HEAT SOURCES



NOTE: For guidance information only. May not represent actual installations.

FIGURE 5. CONTROL ROUTING IN ENGINE COMPARTMENT

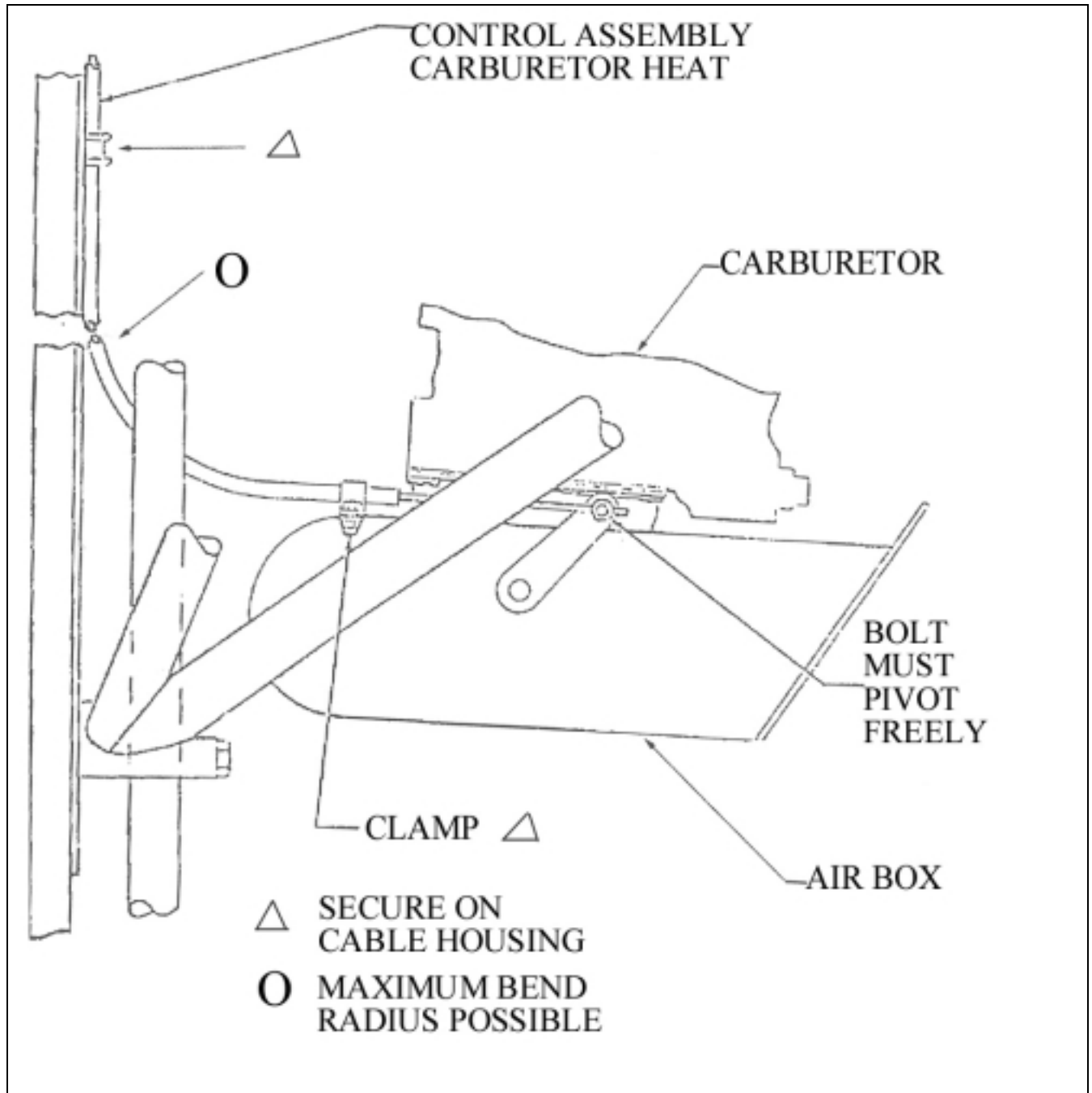

NOTE: For guidance information only. May not represent actual installations.

FIGURE 6. CONTROL CABLE BEND RADII

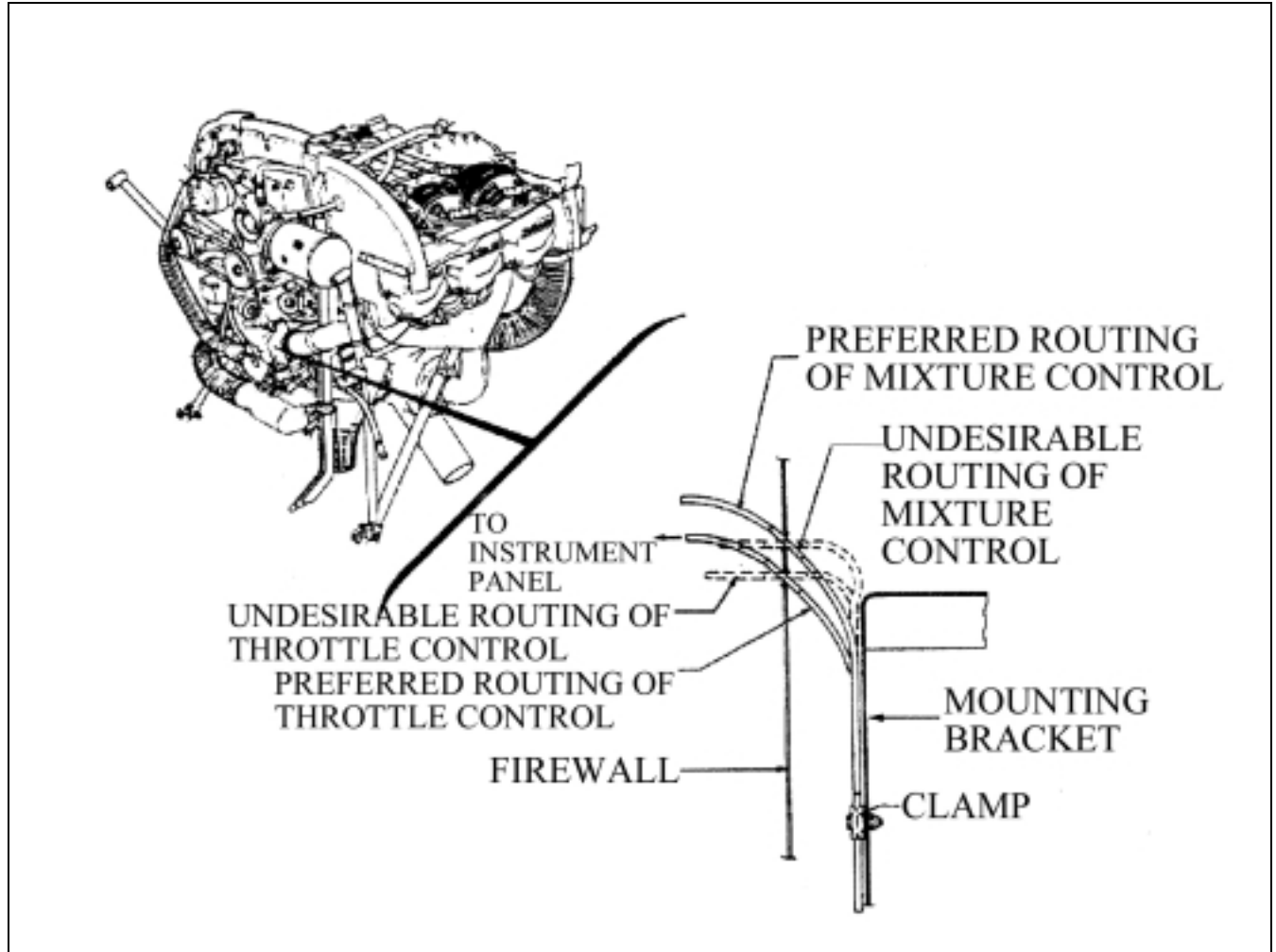

NOTE: For guidance information only. May not represent actual installations.

FIGURE 7. CONTROL SYSTEM OVERVIEW

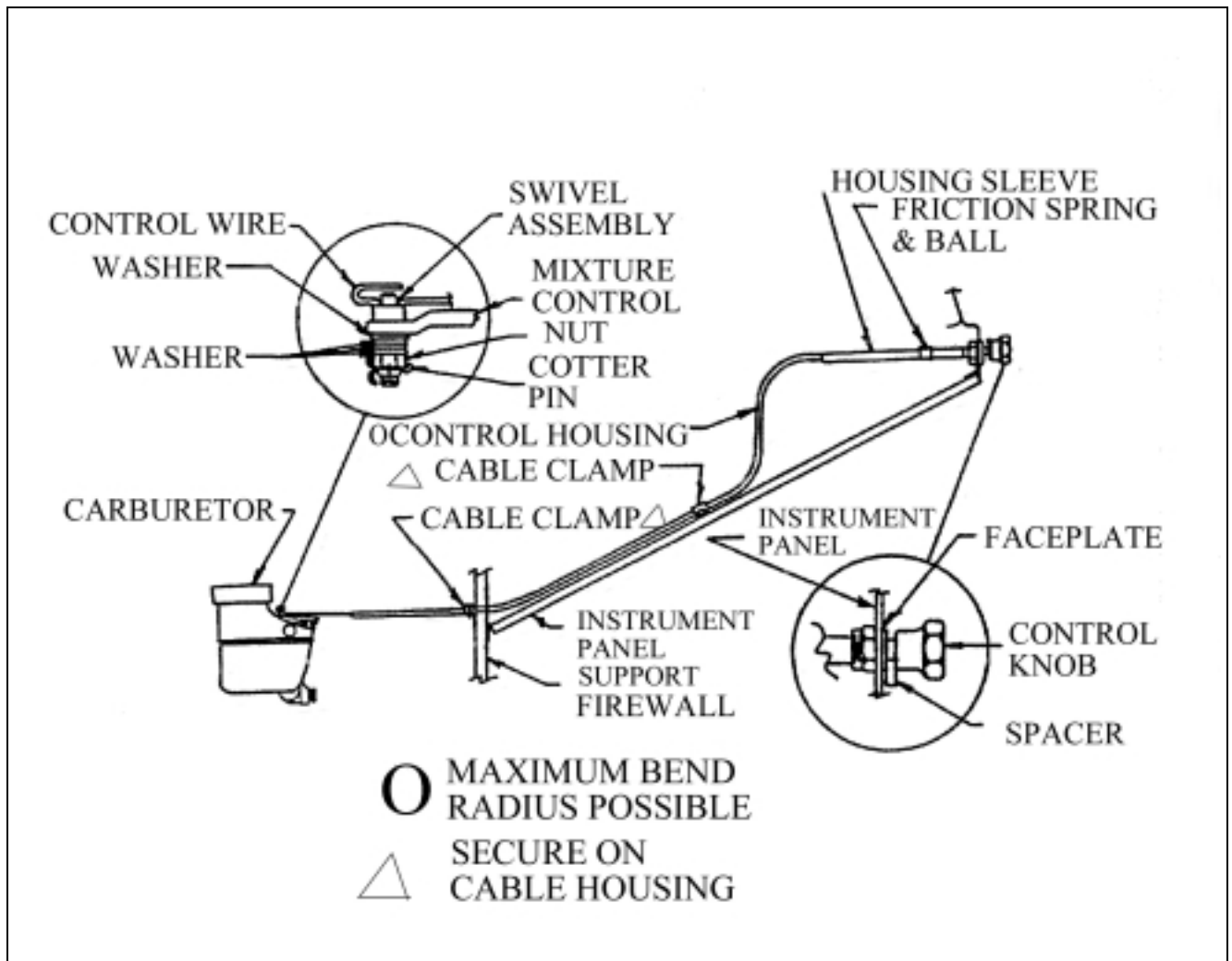

NOTE: For guidance information only. May not represent actual installations.

**FIGURE 8. CONTROL CABLE ROUTING IN HIGH
HEAT SOURCE AREAS**

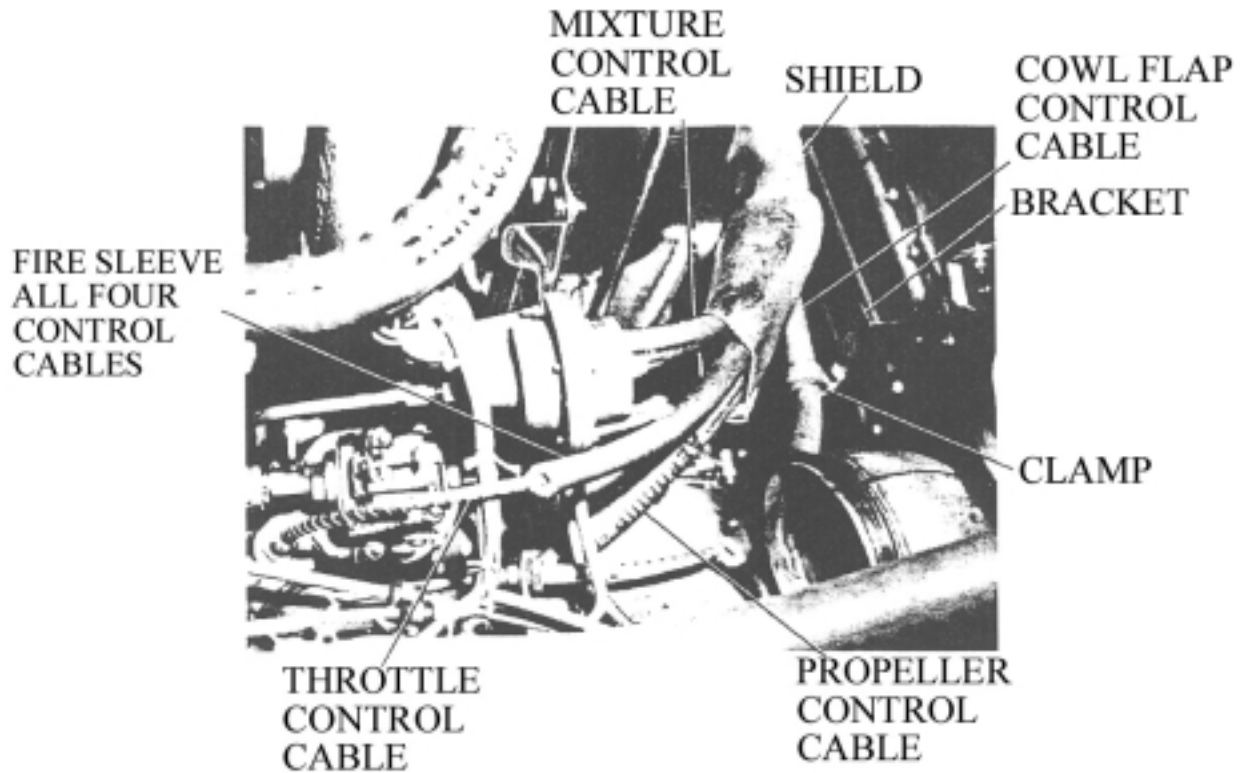

NOTE: For guidance information only. May not represent actual installations.

FIGURE 9. CONTROL CABLE SECURITY

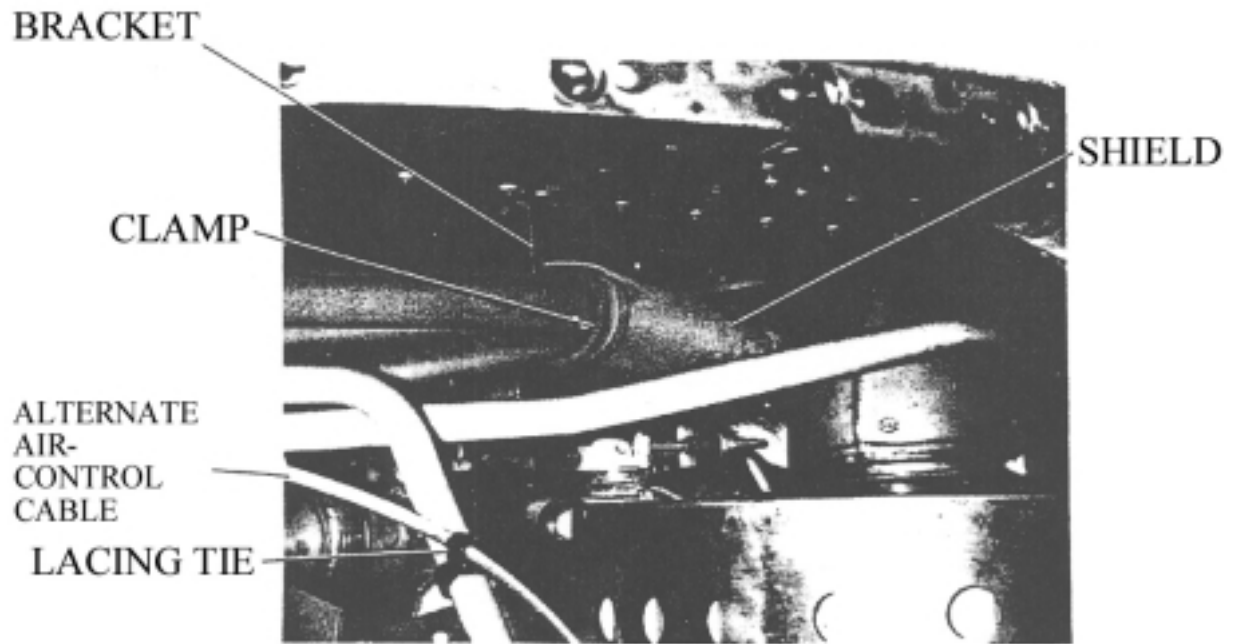

NOTE: For guidance information only. May not represent actual installations.