

# UNIFIED FACILITIES CRITERIA (UFC)

---

## ELECTRICAL ENGINEERING PRELIMINARY CONSIDERATIONS



APPROVED FOR PUBLIC RELEASE; DISTRIBUTION UNLIMITED

## UNIFIED FACILITIES CRITERIA (UFC)

### **ELECTRICAL ENGINEERING PRELIMINARY CONSIDERATIONS**

Any copyrighted material included in this UFC is identified at its point of use.  
Use of the copyrighted material apart from this UFC must have the permission of the  
copyright holder.

U.S. ARMY CORPS OF ENGINEERS

NAVAL FACILITIES ENGINEERING COMMAND (Preparing Activity)

AIR FORCE CIVIL ENGINEERING SUPPORT AGENCY

Record of Changes (changes indicated by \1\ ... /1/ )

<u>Change No.</u>	<u>Date</u>	<u>Location</u>

**UFC 3-501-03N**  
**16 January 2004**

## FOREWORD

The Unified Facilities Criteria (UFC) system is prescribed by MIL-STD 3007 and provides planning, design, construction, sustainment, restoration, and modernization criteria, and applies to the Military Departments, the Defense Agencies, and the DoD Field Activities in accordance with [USD\(AT&L\) Memorandum](#) dated 29 May 2002. UFC will be used for all DoD projects and work for other customers where appropriate. All construction outside of the United States is also governed by Status of forces Agreements (SOFA), Host Nation Funded Construction Agreements (HNFA), and in some instances, Bilateral Infrastructure Agreements (BIA.) Therefore, the acquisition team must ensure compliance with the more stringent of the UFC, the SOFA, the HNFA, and the BIA, as applicable.

UFC are living documents and will be periodically reviewed, updated, and made available to users as part of the Services' responsibility for providing technical criteria for military construction. Headquarters, U.S. Army Corps of Engineers (HQUSACE), Naval Facilities Engineering Command (NAVFAC), and Air Force Civil Engineer Support Agency (AFCESA) are responsible for administration of the UFC system. Defense agencies should contact the preparing service for document interpretation and improvements. Technical content of UFC is the responsibility of the cognizant DoD working group. Recommended changes with supporting rationale should be sent to the respective service proponent office by the following electronic form: [Criteria Change Request \(CCR\)](#). The form is also accessible from the Internet sites listed below.

UFC are effective upon issuance and are distributed only in electronic media from the following source:

- Whole Building Design Guide web site <http://dod.wbdg.org/>.

Hard copies of UFC printed from electronic media should be checked against the current electronic version prior to use to ensure that they are current.

### AUTHORIZED BY:



DONALD L. BASHAM, P.E.  
 Chief, Engineering and Construction  
 U.S. Army Corps of Engineers



DR. JAMES W. WRIGHT, P.E.  
 Chief Engineer  
 Naval Facilities Engineering Command

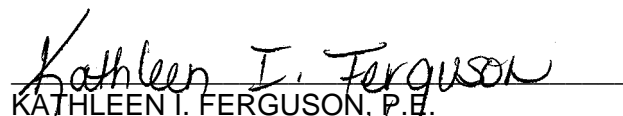

KATHLEEN I. FERGUSON, P.E.  
 The Deputy Civil Engineer  
 DCS/Installations & Logistics  
 Department of the Air Force

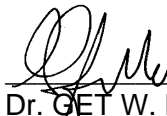

Dr. GET W. MOY, P.E.  
 Director, Installations Requirements and  
 Management  
 Office of the Deputy Under Secretary of Defense  
 (Installations and Environment)

**CONTENTS**

	Page
CHAPTER 1 INTRODUCTION	
Paragraph 1-1 PURPOSE AND SCOPE .....	1-1
1-2 APPLICABILITY .....	1-1
1-2.1 General Building Requirements .....	1-1
1-2.2 Safety .....	1-1
1-2.3 Fire Protection .....	1-1
1-2.4 Antiterrorism/Force Protection .....	1-1
1-3 REFERENCES .....	1-2
 APPENDIX A MIL-HDBK 1004/1, MAY 1988.....	 A-1

## CHAPTER 1

### INTRODUCTION

1-1 **PURPOSE AND SCOPE.** This UFC is comprised of two sections. Chapter 1 introduces this UFC and provides a listing of references to other Tri-Service documents closely related to the subject. Appendix A contains the full text copy of the previously released Military Handbook (MIL-HDBK) on this subject. This UFC serves as criteria until such time as the full text UFC is developed from the MIL-HDBK and other sources.

This UFC provides general criteria for preliminary design considerations for electrical engineering.

Note that this document does not constitute a detailed technical design, maintenance or operations manual, and is issued as a general guide to the considerations associated with design of economical, efficient and environmentally acceptable heating plants.

1-2 **APPLICABILITY.** This UFC applies to all Navy service elements and Navy contractors; Army service elements should use the references cited in paragraph 1-3 below; all other DoD agencies may use either document unless explicitly directed otherwise.

1-2.1 **GENERAL BUILDING REQUIREMENTS.** All DoD facilities must comply with UFC 1-200-01, *Design: General Building Requirements*. If any conflict occurs between this UFC and UFC 1-200-01, the requirements of UFC 1-200-01 take precedence.

1-2.2 **SAFETY.** All DoD facilities must comply with DODINST 6055.1 and applicable Occupational Safety and Health Administration (OSHA) safety and health standards.

**NOTE:** All **NAVY** projects, must comply with OPNAVINST 5100.23 (series), *Navy Occupational Safety and Health Program Manual*. The most recent publication in this series can be accessed at the NAVFAC Safety web site: [www.navfac.navy.mil/safety/pub.htm](http://www.navfac.navy.mil/safety/pub.htm). If any conflict occurs between this UFC and OPNAVINST 5100.23, the requirements of OPNAVINST 5100.23 take precedence.

1-2.3 **FIRE PROTECTION.** All DoD facilities must comply with UFC 3-600-01, *Design: Fire Protection Engineering for Facilities*. If any conflict occurs between this UFC and UFC 3-600-01, the requirements of UFC 3-600-01 take precedence.

1-2.4 **ANTITERRORISM/FORCE PROTECTION.** All DoD facilities must comply with UFC 4-010-01, *Design: DoD Minimum Antiterrorism Standards for Buildings*. If any conflict occurs between this UFC and UFC 4-010-01, the requirements of UFC 4-010-01 take precedence.

1-3           **REFERENCES.** The following Tri-Service publications have valuable information on the subject of this UFC. When the full text UFC is developed for this subject, applicable portions of these documents will be incorporated into the text. The designer is encouraged to access and review these documents as well as the references cited in Appendix A, MIL-HDBK 1004/1.

1.     US Army Corps of Engineers  
      Commander                           **USACE TM 5-683**  
      USACE Publication Depot         Facilities Engineering - Electrical Interior  
      ATTN: CEIM-IM-PD                 Facilities  
      2803 52nd Avenue                 15 December 1995  
      Hyattsville, MD 20781-1102      **USACE TM 5-684**  
      (301) 394-0081 fax: 0084         Facilities Engineering - Electrical Exterior  
  Facilities  
  29 November 1996

[karl.abt@hq02.usace.army.mil](mailto:karl.abt@hq02.usace.army.mil)  
<http://www.usace.army.mil/inet/usace-docs/>

UFC 3-501-03N  
16 January 2004

## **APPENDIX A**

# **MIL-HDBK 1004/1 ELECTRICAL ENGINEERING PRELIMINARY DESIGN CONSIDERATIONS**

MIL-HDBK-1004/1  
30 MAY 1988  
SUPERSEDING  
DM-4.1  
MARCH 1983

MILITARY HANDBOOK  
ELECTRICAL ENGINEERING  
PRELIMINARY DESIGN CONSIDERATIONS

AMSC N/A

DISTRIBUTION STATEMENT A. APPROVED FOR PUBLIC RELEASE: DISTRIBUTION IS  
UNLIMITED

AREA FACR



## ABSTRACT

This handbook provides basic design guidance in the proper selection of electric power sources and distribution systems. It was developed from extensive reevaluation of facilities and is presented for use by experienced architects and engineers. The contents cover electric power preliminary design considerations such as preliminary data, estimation of loads, selection of electric power source, uninterruptible power supply (UPS) system design, installation of distribution systems, levels of distribution voltage, grounding of distribution systems, and selection of distribution systems.

PAGE iv INTENTIONALLY BLANK

## FOREWORD

This handbook has been developed from an evaluation of facilities in the shore establishment, from surveys of the availability of new materials and construction methods, and from selection of the best design practices of the Naval Facilities Engineering Command (NAVFACENGCOM), other Government agencies, and the private sector. This handbook was prepared using, to the maximum extent feasible, national professional society, association, and institute standards. Deviations from this criteria, in the planning, engineering, design, and construction of naval shore facilities, cannot be made without prior approval of NAVFACENGCOMHQ Code 04.

Design cannot remain static any more than can the functions it serves or the technologies it uses. Accordingly, recommendations for improvement are encouraged and should be furnished to Commanding Officer, Chesapeake Division, Naval Facilities Engineering Command, Code 406, Washington Naval Yard, Washington, DC 20374-2121, telephone (202) 433-3314.

THIS HANDBOOK SHALL NOT BE USED AS A REFERENCE DOCUMENT FOR PROCUREMENT OF FACILITIES CONSTRUCTION. IT IS TO BE USED IN THE PURCHASE OF FACILITIES ENGINEERING STUDIES AND DESIGN (FINAL PLANS, SPECIFICATIONS, AND COST ESTIMATES). DO NOT REFERENCE IT IN MILITARY OR FEDERAL SPECIFICATIONS OR OTHER PROCUREMENT DOCUMENTS.

## ELECTRICAL ENGINEERING DESIGN CRITERIA MANUALS

Criteria Manual	Title	PA
MIL-HDBK-1004/1	Preliminary Design Considerations	CHESDIV
MIL-HDBK-1004/2	Power Distribution Systems	PACDIV
MIL-HDBK-1004/3	Switchgear and Relaying	CHESDIV
MIL-HDBK-1004/4	Electrical Utilization Systems	CHESDIV
4.05	400-Hertz Medium-Voltage Conversion and Low-Voltage Systems	CHESDIV
MIL-HDBK-1004/6	Lightning Protection	CHESDIV
4.07	Wire Communication and Signal Systems	CHESDIV
4.09	Energy Monitoring and Control Systems (Army)	HDQTRS

NOTE: Design manuals, when revised, will be converted to military handbooks.

This handbook is issued to provide immediate guidance to the user. However, it may or may not conform to format requirements of MIL-HDBK-1006/3 and will be corrected on the next update.

## PRELIMINARY ELECTRICAL DESIGN CONSIDERATIONS

## CONTENTS

	Page
<b>Section 1</b>	<b>PRELIMINARY DATA</b>
1.1	Scope .....1
1.2	Cancellation .....1
1.3	Related Criteria .....1
1.4	Other Government Criteria Sources .....1
1.5	Other Sources of Criteria .....1
1.6	Load Data .....2
1.7	Load Analysis .....2
1.8	Terminology .....2
1.8.1	Demand Factor .....2
1.8.2	Coincidence Factor .....2
1.8.3	Diversity Factor .....2
1.8.4	Load Factor .....2
1.8.5	Maximum Demand .....2
<b>Section 2</b>	<b>ESTIMATION OF LOADS</b>
2.1	Preparation of Load Data .....3
2.2	Individual Loads .....3
2.2.1	Lighting .....3
2.2.1.1	Small Appliance Loads .....3
2.2.1.2	Electric Power Loads .....3
2.2.1.3	System Loss .....3
2.2.2	Demand and Load Factors .....10
2.2.2.1	Guides for Demand Factors .....10
2.2.2.2	Guides for Load Factors .....10
2.2.3	Load Growth .....10
2.2.4	Emergency Loads .....17
2.3	Area Loads .....17
2.3.1	General Loads .....17
2.3.2	Coincidence Factor .....17
2.3.2.1	Relationships .....17
2.3.2.2	Selection .....17
2.3.2.3	Electric Power Consumption .....17
2.3.2.4	Influencing Factors .....23
2.3.2.5	Individual Loads .....23
2.3.2.6	Groups of Loads or Areas .....23
2.3.3	Load Growth .....23
2.3.4	System Losses .....23
2.3.5	Emergency Loads .....24
2.3.6	Expansion .....24
2.4	Activity Loads .....24
2.4.1	General Loads .....24
2.4.2	Coincidence Factor .....24
2.4.3	Load Growth .....24
2.4.4	Expansion .....24

Section 3	SELECTION OF ELECTRIC POWER SOURCE	
3.1	Policy .....	25
3.2	Economic Factors .....	25
3.3	Electric Power Sources .....	25
3.3.1	Primary .....	25
3.3.2	Standby .....	25
3.3.3	Emergency .....	25
3.3.4	Uninterruptible (No-Break) Electric Power .....	26
3.4	Acceptable Electric Power Sources .....	26
3.4.1	Primary .....	26
3.4.2	Standby .....	26
3.4.3	Emergency .....	26
3.4.4	Uninterruptible (No-Break) Electric Power .....	26
3.5	Purchased Electric Power Requirements .....	26
3.5.1	Adequacy .....	27
3.5.2	Reliability .....	27
3.5.3	Rates .....	27
3.5.4	Primary Service Right-of-Way .....	27
3.5.5	Primary Substations .....	28
3.5.5.1	Voltage .....	28
3.5.5.2	Economics .....	
Section 4	UNINTERRUPTIBLE POWER SYSTEMS	
4.1	Requirements .....	29
4.2	Criteria .....	29
4.3	Power Load Categories .....	29
4.4	Definitions .....	30
4.5	Redundancy .....	34
4.5.1	"Cold" Standby Redundant UPS System .....	34
4.5.2	Parallel Redundant UPS System .....	34
4.6	Electric Service and Bypass Connectors .....	34
4.6.1	Electric Service Size .....	34
4.6.2	Maintenance Bypass Provisions .....	34
4.7	UPS Distribution System .....	36
4.7.1	Critical Load Protection .....	36
4.7.2	Critical Motor Loads .....	36
4.8	Emergency Electric Power Source Requirements .....	36
4.8.1	Automatic Operation .....	36
4.8.2	Paralleling .....	36
4.8.3	Starting and Maintenance Considerations .....	37
4.8.4	Service Configuration for Small Loads .....	37
4.8.5	Battery Charging Restrictions .....	37
4.9	Electromagnetic Interference (EMI) Suppression .....	37
4.10	UPS Battery .....	37
4.11	Remote Alarms .....	37
4.12	UPS and Battery Room Requirements .....	37
4.12.1	Installation Considerations .....	38
4.12.1	NEC, OSHA, and ANSI Requirements .....	38
4.12.3	Emergency Lighting Requirements .....	38
4.12.4	Telephone Requirements .....	38
4.13	Environmental Control .....	38

<b>Section 5</b>	<b>INSTALLATION OF DISTRIBUTION SYSTEM</b>	
5.1	Overhead Method .....	39
5.1.1	General .....	39
5.1.2	Limitations .....	39
5.2	Underground Method .....	39
5.2.1	Applications .....	39
5.2.2	Expansibility .....	39
<b>Section 6</b>	<b>LEVELS OF DISTRIBUTION VOLTAGE</b>	
6.1	Criteria Coverage .....	40
6.2	System Voltages .....	40
6.2.1	Power Generated at Site .....	40
6.2.2	Purchased Energy .....	40
6.2.2.1	2,400 V System .....	40
6.2.2.2	4,160 V System .....	40
6.2.2.3	6,900 V System .....	40
6.2.2.4	12,000 V to 13,800 V Systems .....	40
6.2.2.5	15,000 V to 34,500 V Systems .....	40
<b>Section 7</b>	<b>GROUNDING OF DISTRIBUTION SYSTEMS</b>	
7.1	General Requirements .....	41
7.2	Methods .....	41
7.2.1	Solid Grounding .....	41
7.2.2	Resistance Grounding .....	41
7.2.3	Reactance Grounding .....	41
<b>Section 8</b>	<b>SELECTION OF DISTRIBUTION SYSTEMS</b>	
8.1	Selection Factors .....	42
8.2	Systems Available .....	42
8.2.1	Conventional Simple-Radial Distribution System .....	42
8.2.2	Modern Simple-Radial Distribution System .....	42
8.2.3	Modified Modern Simple-Radial Distribution System .....	42
8.2.4	Loop Primary-Radial Distribution Type .....	42
8.2.5	Banked Secondary-Radial Distribution System .....	42
8.2.6	Primary Selective-Radial Distribution System .....	42
8.2.7	Secondary Selective-Radial Distribution System .....	49
8.2.8	Simple Network Distribution System .....	49
8.2.8.1	Network Protector .....	49
8.2.8.2	Limitation .....	49
8.2.8.3	Secondary Loops .....	49
8.2.9	Simple Spot-Network Distribution System .....	52
8.2.10	Primary Selective Network Distribution System .....	52
8.2.11	Primary Selective Spot-Network Distribution System .....	52

## FIGURES

1	Theoretical Relationship Between Load Factor and Coincidence Factor at U.S. Naval Shore Establishments .....	20
2	Typical Nonredundant Configuration (UPS) .....	32
3	Typical "Cold" Standby Redundant Configuration (UPS) .....	33
4	Typical Parallel Redundant Configuration (UPS) .....	35
5	Conventional Simple-Radial Distribution System .....	43
6	Modern Simple-Radial Distribution System .....	44
7	Modified Modern Simple-Radial Distribution System .....	45
8	Loop Primary-Radial Distribution System .....	46
9	Banked Secondary-Radial Distribution System .....	47
10	Primary Selective-Radial Distribution System .....	48
11	Secondary Selective-Radial Distribution System .....	50
12	Simple Network Distribution System .....	51
13	Simple Spot-Network Distribution System .....	53
14	Primary Selective Network Distribution System .....	54
15	Primary Selective Spot-Network Distribution System .....	55

## TABLES

1	Factors for Individual Facilities by Navy Category Code .....	4
2	Demand Factors for Specific Loads .....	11
3	Annual Hours Use of Demand for Specific Loads .....	11
4	Academic Building (Code 171-10) Demand and Load Factor Calculations .....	12
5	Guides for Selection of Demand Factors .....	13
6	Guides for Selection of Load Factors .....	15
7	Method of Calculating Coincident Peak Demand .....	18
8	Relationship Between Load Factor and Coincidence Factor .....	21

BIBLIOGRAPHY .....	56
--------------------	----

REFERENCES .....	57
------------------	----



## Section 1: PRELIMINARY DATA

1.1 Scope. This handbook provides the criteria necessary for the proper selection of electric power sources and distribution systems. It covers preliminary load estimating factors, electrical power sources, and distribution systems.

1.2 Cancellation. This handbook cancels and supersedes DM-4.1, Electrical Engineering Preliminary Design Considerations, of December 1979, and change dated 1 March 1983.

1.3 Load Data. Before specific electric power sources and distribution systems can be considered, realistic preliminary load data must be compiled. The expected electric power demand on intermediate substations, and on the main electric power supply, shall be calculated from the connected load layout by applying appropriate factors. Determine these factors by load analysis and by combining loads progressively. To combine the loads, start at the ends of the smallest feeders and work back to the electric power source. Because all loads must be on a common kilowatt (kW) or kilovolt-ampere (kVA) basis, it is necessary to convert motor horsepower ratings to input kilowatts or kilovolt-amperes before combining them with other loads already expressed in those terms. Preliminary electric power load estimates can be made by using the approximate value of one kilovolt-ampere of input per horsepower (hp) at full load. Preliminary estimates of lighting loads may be made by assuming watts per ft<sup>2</sup> (m<sup>2</sup>) of building area.

1.4 Load Analysis. To determine appropriate load estimating factors, using the tables and factors in this manual as guides analyze the characteristics of each load. Consider items such as environmental conditions of weather, geographical location, and working hours, as the situation dictates. Notice that when the load densities in w/ft<sup>2</sup> (m<sup>2</sup>) are used only in preliminary estimates, the demand and load factors will be used in the final designs.

1.5 Terminology. Five terms are essential to the analysis of load characteristics: demand factor, coincidence factor, diversity factor, and maximum demand. These terms are defined in paras. 1.5.1 through 1.5.4.

1.5.1 Demand Factor. The demand factor is the ratio of the maximum demand on a system to the total connected load of the system or

$$\text{EQUATION: Demand factor} = \frac{\text{Maximum demand load}}{\text{Total load connected}} \quad (1)$$

1.5.2 Coincidence Factor. The coincidence factor is the ratio of the maximum demand of a system, or part under consideration, to the sum of the individual maximum demands of the subdivisions or

$$\text{EQUATION: Coincidence factor} = \frac{\text{Maximum system demand}}{\text{Sum of individual maximum demands}} \quad (2)$$

1.5.3 Diversity Factor. The diversity factor is the reciprocal of the coincidence factor or

$$\text{EQUATION: Diversity factor} = \frac{\text{Sum of individual maximum demands}}{\text{Maximum system demand}} \quad (3)$$

1.5.4 Load Factor. The load factor is the ratio of the average load over a designated period of time, usually 1 year, to the maximum load occurring in that period or

$$\text{EQUATION: Load factor} = \frac{\text{Average load}}{\text{Maximum load}} \quad (4)$$

1.5.5 Maximum Demand. The maximum demand is the integrated demand for a specified time interval, i.e., 5 minutes, 15 minutes, 30 minutes, or other appropriate time intervals, rather than the instantaneous or peak demand.

## Section 2: ESTIMATION OF LOADS

2.1 Preparation of Load Data. Load data are generally computed in steps such as:

- a) individual loads,
- b) area loads, and
- c) activity loads.

A particular design problem may be limited to step a), to steps a) and b), or may encompass steps a), b), and c). This section outlines each step as a separate entity, dependent only on previous steps for data. Paragraphs 2.2 through 2.4.4 describe the three loads.

2.2 Individual Loads. Individual loads are those with one incoming service supplying utilization voltage to the premises. In general, these loads would comprise single structures. Large structures could contain more than one function; for example, aircraft operations, aircraft fire and rescue stations, and photographic buildings. Under this condition, factors that have been developed and keyed to Navy category codes (refer to Table 1) would be used. In this case, the factors listed under Navy Category Code 141-40, 141-20, and 141-60, respectively, would be combined to obtain the total load.

2.2.1 Lighting. To eliminate lighting loads, divide a facility area into its significant components by function (for example, office, storage, mechanical, and corridor). Determine the average lighting level and type of light source for each area. Consider requirements for supplementary lighting (for example, floodlighting, security lighting, and special task lighting). Preliminary load estimates may be made based on the following load allowances:

- a)  $1 \text{ W/ft}^2$  ( $10.76 \text{ W/m}^2$ ) for each 6 to 8 fc (60 to 80 dekalux) of incandescent illumination.
- b)  $1 \text{ W/ft}^2$  for each 15 to 20 fc (150 to 200 dekalux) of fluorescent illumination.
- c)  $1 \text{ W/ft}^2$  for each 12 to 18 fc (120 to 180 dekalux) of mercury vapor illumination.
- d)  $1 \text{ W/ft}^2$  for each 26 to 36 fc (260 to 360 dekalux) of metal halide illumination.
- e)  $1 \text{ W/ft}^2$  for each 33 to 54 fc (330 to 540 dekalux) of high pressure sodium illumination.

2.2.1.1 Small Appliance Loads. Small appliance loads shall include those served by general purpose receptacles. In general, the dividing of areas by function for estimating lighting loads will serve for estimating small appliance loads. The determination of loads requires not only a knowledge of the function of an area, but to what extent its occupants use small appliances. For example, an office area demand may average about  $1 \text{ W/ft}^2$

Table 1  
Factors for Individual Facilities by Navy Category Code (See Note 1)

NAVY CODE	DESCRIPTION	DEMAND FACTOR (%)	LOAD FACTOR (%)
100	Operational and Training Facilities:		
121	Aircraft fueling/dispensing facility . . . . .	.40-60	16-20
122	Marine fuel dispensing . . . . .	.40-60	16-20
123 10	Filling station . . . . .	.40-60	13-17
125 16	Miscellaneous POL pipeline facilities . . . . .	.100	13-17
126	Liquid fueling and dispensing-other . . . . .	.40-60	3- 7
131	Communications - buildings . . . . .	.60-65	70-75
131 40	Telephone exchange building . . . . .	.55-70	20-25
133 75	Air surveillance radar building . . . . .	.55-70	70-75
137 40	Port control office . . . . .	.55-70	20-25
141 11	Air passenger terminal building . . . . .	.65-80	28-32
141 20	Aircraft fire and rescue station . . . . .	.25-35	13-17
141 30	Aircraft line operations building . . . . .	.65-80	24-28
141 40	Aircraft operations building *EXC 141-70* . . . . .	.65-80	28-32
141 60	Photographic building . . . . .	.65-80	16-20
171 10	Academic instruction building . . . . .	.40-60	22-26
171 20	Applied instruction building . . . . .	.35-65	24-28
171 40	Drill Hall . . . . .	.75-85	3- 7
200	Maintenance and Production Facilities:		
211 05	Maintenance Hangar O/H space (high bay) . . . . .	.45-50	28-30
211 06	Maintenance Hangar - 01 space (crew equipment). . . . .	.45-50	28-30
211 07	Maintenance Hangar - 02 space (administrative) . . . . .	.45-50	28-30
211 10	Aircraft overhaul and repair shop (NARF) . . . . .	.32-38	25-30
211 12	Paint/finishing hangar . . . . .	.65-75	25-27
211 20	Engine overhaul shop (NARF) . . . . .	.32-38	20-25
211 30	Aircraft/engine accessories overhaul shop (NAR) . . . . .	.32-38	25-30
211 75	Parachute/survival equipment . . . . .	.60-65	23-28
211 81	Engine test cell (Non-NARF) . . . . .	.42-48	25-30
211 96	Maintenance, aircraft spares storage (MISC) . . . . .	.58-63	23-28
212 20	Missile equipment maintenance ship . . . . .	.35-40	15-20
213 10	Drydock . . . . .	.5-10	0.5-1
214-10	Combat vehicle maintenance shop . . . . .	.55-65	20-25
214-20	Automobile vehicle maintenance - noncombat . . . . .	.55-65	20-25
215	Maintenance - weapons / spares . . . . .	.70-80	20-25
216 10	Ammunition rework and overhaul shop . . . . .	.35-40	18-22
216 20	Rocket rework and overhaul shop . . . . .	.35-40	18-22
216 30	Mines and depth charge rework shop . . . . .	.35-40	15-20
216 40	Torpedo shop . . . . .	.45-55	18-22
216 50	Special weapons shop . . . . .	.35-40	18-22
216 60	Quality evaluation laboratory . . . . .	.55-65	22-27

Note 1: Demand factors include allowance for system loss.

Table 1 (Continued)  
Factors for Individual Facilities by Navy Category Code[1]

NAVY CODE	DESCRIPTION	DEMAND FACTOR (%)	LOAD FACTOR (%)
217 10	Electronics/communications maintenance shop . . . . .	.35-40	20-25
218 20	Construction/weight handling equipment shop . . . . .	.35-45	20-25
218 40	Railroad equipment shop . . . . .	.35-45	15-20
218 50	Battery shop . . . . .	.55-65	20-25
219 10	Public works shop . . . . .	.32-38	18-22
221 10	Aircraft engine assembly plant . . . . .	.32-38	20-25
222 10	Missile assembly buildings . . . . .	.35-40	15-20
222 20	Missile handling launch equipment . . . . .	.35-40	15-20
223 10	Fabrication/assembly building . . . . .	.22-27	24-29
225 10	Small arms plant . . . . .	.15-20	22-27
225 20	Light gun (20mm/51n) plant . . . . .	.15-20	22-27
225 30	Heavy gun (6/161n) plant . . . . .	.16-21	21-26
225 50	Launcher/projector plant . . . . .	.15-20	22-27
226 10	Bag charge filling plant . . . . .	.62-67	23-28
226 15	Case filling plant . . . . .	.35-40	23-28
226 20	Case overhaul tank repair facility . . . . .	.35-40	18-22
226 35	Major-caliber projectile loading plant . . . . .	.35-40	18-22
226 40	Medium-caliber projectile loading plant . . . . .	.35-40	18-22
226 55	Cast high explosives filling plant . . . . .	.35-40	18-22
226 65	Propellant and related chemical facility . . . . .	.30-40	32-38
227 10	Radio and radar equipment plant . . . . .	.50-55	23-28
227 10	Sonar equipment plant . . . . .	.50-55	23-28
228 10	Parachute/survival equipment plant . . . . .	.35-40	20-25
229 10	Asphalt plant . . . . .	.75-80	7-12
229 20	Concrete batching plant . . . . .	.75-80	15-20
229 30	Rock crusher plant . . . . .	.75-80	15-20
229 40	Sawmill . . . . .	.45-55	15-20
300	Research, Development, Test & Evaluation Facilities:		
310 13	Chemistry and Toxicology Laboratory . . . . .	.70-80	22-28
310 15	Materials Laboratory . . . . .	.30-35	27-32
310 19	Physics Laboratory . . . . .	.70-80	22-28
316 10	Ammunition, explosives, and toxics laboratory . . . . .	.28-32	20-25
317 20	Electrical and electronics systems laboratory . . . . .	.20-30	3-7
400	Supply Facilities:		
421	Ammunition storage installation . . . . .	.75-80	.....
423	Ammunition storage-liquid propellant . . . . .	.75-80	20-25
431 10	Cold storage warehouse . . . . .	.70-75	20-25
441 10	General warehouse Navy . . . . .	.75-80	23-28
441 20	Controlled humidity warehouse . . . . .	.60-65	33-38
441 30	Hazardous/flammable storehouse . . . . .	.75-80	20-25
441 40	Underground storage . . . . .	.65-70	23-28
441 70	Disposal, salvage, scrap building . . . . .	.35-40	25-20

[1] Demand factors include allowance for system loss.

Table 1 (Continued)  
 Factors for Individual Facilities by Navy Category Code[1]

NAVY CODE	DESCRIPTION	DEMAND FACTOR (%)	LOAD FACTOR (%)
500	Hospital-Medical Facilities:		
510 10	Hospital . . . . .	.38-42	45-50
530 20	Laboratory . . . . .	.32-37	20-25
540 10	Dental Clinic . . . . .	.35-40	18-23
550 10	Medical Clinic . . . . .	.45-50	20-23
600	Administrative Facilities:		
610 10	Administrative Office . . . . .	.50-65	20-35
620 10	Administrative facility, underground . . . . .	.50-65	35-40
700	Housing and Community Facilities:		
711	Family housing-dwellings . . . . .	.60-70	10-15
712	Substandard: Trailers-family housing . . . . .	.70-75	10-15
714 10	Detached garages . . . . .	.40-50	2-4
721 11	Bachelor enlisted quarters . . . . .	.35-40	38-42
721 12	Bachelor enlisted quarters E5/E6 . . . . .	.35-40	38-42
721 13	Bachelor enlisted quarters E7/E9 . . . . .	.35-40	38-42
721 30	Civilian barracks GS 01/6 . . . . .	.35-40	38-42
721 40	Disciplinary barracks . . . . .	.35-40	38-42
722 10	Detached dining facilities, enlisted men . . . . .	.30-35	45-60
723 20	Latrine, detached . . . . .	.75-80	20-25
723 30	Laundry, detached . . . . .	.30-35	20-25
723 40	Garage, detached . . . . .	.40-50	2-4
724 11	UOPH, W-1/O-2 . . . . .	.40-50	20-25
724 12	UOPH, O-3 and above . . . . .	.40-50	20-25
724 22	Civilian quarters, GS-7/PLS . . . . .	.40-50	20-25
724 30	Dining facility (attached) commissioned personnel . . . . .	.35-40	30-40
730 10	Fire station . . . . .	.25-35	13-17
730 15	Confinement facility . . . . .	.60-65	33-38
730 20	Police station . . . . .	.48-53	20-25
730 25	Gate/sentry house . . . . .	.70-75	28-33
730 30	Bakery . . . . .	.30-35	45-60
730 35	Enlisted personnel locker room . . . . .	.75-80	18-23
730 40	Laundry/dry cleaning plant . . . . .	.30-35	20-25
730 45	Dependent school - nursery school . . . . .	.75-80	10-15
730 50	Dependent school - kindergarten . . . . .	.75-80	10-15
730 55	Dependent school - grade school . . . . .	.75-80	10-15
730 60	Dependent school - high school . . . . .	.65-70	12-17
730 65	Fallout shelter . . . . .	.80-85	30-35
730 67	Bus station . . . . .	.80-85	30-35

[1] Demand factors include allowance for system loss.

Table 1 (Continued)  
 Factors for Individual Facilities by Navy Category Code[1]

NAVY CODE	DESCRIPTION	DEMAND FACTOR (%)	LOAD FACTOR (%)
730 70	Decontamination facility . . . . .	.75-80	15-2
730 83	Chapel . . . . .	.65-70	5-25
730 85	Post Office . . . . .	.75-80	20-25
740 01	Exchange retail store . . . . .	.65-70	25-32
740 18	Bank . . . . .	.75-80	20-25
740 23	Commissary including backup storage . . . . .	.55-60	25-30
740 26	Installation restaurant . . . . .	.45-75	15-25
740 30	Exchange auto repair station . . . . .	.40-60	15-20
740 36	Hobby shop, art/crafts . . . . .	.30-40	25-30
740 40	Bowling Alley . . . . .	.70-75	10-15
740 43	Gymnasium . . . . .	.70-75	20-45
740 46	Skating rink . . . . .	.70-75	10-15
740 50	Field house . . . . .	.75-80	7-12
740 53	Indoor swimming pool . . . . .	.55-60	25-50
740 56	Theater . . . . .	.45-55	8-13
740 60	Commissioned officers' mess, open . . . . .	.55-60	15-20
740 63	Enlisted personnel club . . . . .	.55-60	18-23
740 66	Petty officers' mess, open . . . . .	.55-60	18-23
740 70	Mess open, E-7 through E-9 . . . . .	.55-60	15-20
740 76	Library . . . . .	.75-80	30-35
740 80	Golf club house . . . . .	.75-80	15-20
740 86	Exchange installation warehouse . . . . .	.58-63	23-28
740 88	Educational services office . . . . .	.70-75	30-35
760 10	Museum/memorial building . . . . .	.75-80	30-35
800	Utilities and Ground Improvements:		
811 10	Electric power plant-diesel . . . . .	.60-65	58-63
811 25	Electric power plant-steam . . . . .	.60-65	58-63
811 45	Electric power plant-gas turbine . . . . .	.60-65	58-63
811 60	Standby generator plant . . . . .	.75-80	5-10
812 20	Street lighting . . . . .	.95-..	46-..
812 40	Perimeter/security lighting . . . . .	.80-85	22-27
813 20	Substation, more than 499 KV . . . . .	.25-30	20-25
821 12	Fossil fuel heating plant - medium . . . . .	.55-60	30-60
821 22	Fossil fuel heating plant - large . . . . .	.55-60	30-60
821 50	Non-nuclear steam plant . . . . .	.50-55	30-40
826 20	Chilled water plant 25/100 tons . . . . .	.60-70	25-30
827 20	Air conditioning-chilled water transmission/ distribution system - medium (25/100 tons) . . . . .	.60-70	25-30
831 10	Combination sewage and industrial waste treatment plant . . . . .	.60-70	15-20
832 30	Sewage-industrial waste pumping station . . . . .	.55-60	30-35
833 22	Incinerator building and incinerator . . . . .	.55-60	15-20
841 10	Water treatment facilities . . . . .	.60-80	15-25
841 50	Wells-potable water . . . . .	.60-80	15-25

[1] Demand factors include allowance for system loss.

Table 1 (Continued)  
 Factors for individual Facilities By Navy Category Code[1]

NAVY CODE	DESCRIPTION	DEMAND FACTOR (%)	LOAD FACTOR (%)
843 20	Fire protection pumping station . . . . .	Do not include -operate for test off peak.	
890 20	Compressed air plant . . . . .	.45-50	25-30
890 42	Air-conditioning plant, . . . . .	.60-70	25-30
	Miscellaneous Operational and Training Facilities:		
125 10	POL pipeline . . . . .		
132 10	Antenna - communications . . . . .	.95-...	46-...
	Miscellaneous Facilities for Ship Repair and Shipbuilding . . . . .		
	Ship repair shops:		
213 41	Central tool shop - (06) (E) . . . . .	.32-37	23-28
213 42	Shipfitting shop - (11) (A) . . . . .	.22-27	24-29
213 43	Sheet metal shop - (17) (B) . . . . .	.10-15	15-20
213 44	Forge and heat treatment space (23) (F) . . . . .	.25-30	13-18
213 49	Inside machine shop - (31) (G) . . . . .	.16-21	21-26
213 53	Boiler making shop - (41) (D) . . . . .	.12-17	14-19
213 54	Electrical shop - (51) (M) . . . . .	.33-38	20-25
213 55	Pipefitting shop - (56) (J) . . . . .	.22-27	17-22
213 56	Woodworking shop - (64) (R) . . . . .	.25-30	21-26
213 59	Abrasive blast facility . . . . .	.30-35	10-15
213 60	Paint and blasting shop - (71) (S) . . . . .	.50-55	23-28
213 61	Riggers shop - (72) (T) . . . . .	.50-55	20-25
213 62	Sail loft . . . . .	.35-40	20-25
213 63	Foundry - (81) (K) . . . . .	.35-40	22-27
213 64	Patternmaking shop - (94) (X) . . . . .	.28-33	12-17
213 67	Pumphouse, drydocks . . . . .	75-80	0.1-0.2
	Miscellaneous Facilities for Naval Ordnance		
	Manufacture:		
226	Ammunition components building . . . . .	.15-20	20-25
226	Manufacturing . . . . .	.30-45	17-32
226	Explosive loading . . . . .	.65-70	25-30
226	Miscellaneous explosives storage and handling . . . . .	.65-70	5-10
226	Assembly building . . . . .	.40-50	20-25
226	Detonator building . . . . .	.65-70	20-25
226	Pelleting . . . . .	.40-50	20-25
226	Plastic beading . . . . .	.55-60	18-23
226	Sewing room . . . . .	.35-40	25-30
226	Projective assembly breakdown . . . . .	.55-60	18-23
226	Machine shop . . . . .	.16-21	21-26
226	Phosphorous plant . . . . .	.35-40	25-30
226	TNT detonator (military) . . . . .	.35-40	15-20
226	Ammunition tank box assembly . . . . .	.35-40	15-20
226	Box emptying . . . . .	.35-40	15-20

[1] Demand factors include allowance for system loss.



Table 1 (Continued)  
 Factors for Individual Facilities by Navy Category Code<sup>L1J</sup>

NAVY CODE	Description	DEMAND FACTOR (%)	LOAD FACTOR (%)
226	Plating maintenance . . . . .	.35-40	18-23
226	Mixing . . . . .	.40-45	18-23
226	Segregation fleet return . . . . .	.35-40	15-20
226	Plaster load . . . . .	.35-40	15-20
	Fluoroscope building . . . . .	.45-50	18-23
	Tank building rocket . . . . .	.40-45	15-20
	Hydrostatic test . . . . .	.35-40	15-20
	Phosphorous loading . . . . .	.35-40	15-20
226	Vacuum and hydraulic pump building . . . . .	.35-40	12-17
226	Cable drive . . . . .	.35-40	12-17
226	Dryer building . . . . .	.75-80	3- 8
	Miscellaneous Production Facilities:		
229 50	Printing plant . . . . .	.45-55	25-30
	Miscellaneous Storage Facilities:		
750	Community Facilities - morale, welfare, and recreation - exterior . . . . .	.Determine by load count and time.	
750 30	Outdoor swimming pool installation . . . . .	.80-85	20-25
750 54	Band stand . . . . .	.75-80	15-25
	Miscellaneous Facilities for Utilities and Ground Improvements:		
821 09	Heating plant building (condensate) . . . . .	.55-60	25-40
821 09	Heating plant building (heating) . . . . .	.55-60	30-35
833 40	Garbage house . . . . .	.75-80	20-25
841	Potable water - supply/treatment/storage . . . . .	.Determine by load count and time.	
845 20	Pipeline nonpotable water . . . . .	.55-60	3- 8
852 30	Pedestrian bridge . . . . .	.80-85	20-25
872 20	Guard and watch towers . . . . .	.80-..	46-..
890 20	Compressed air plant . . . . .	.60-65	20-25

<sup>L1J</sup>Demand factors include allowance for system loss.

(10.76 W/m<sup>2</sup>), but could vary from a low of 0.5 W/ft<sup>2</sup> (5.38 W/m<sup>2</sup>) to a high of 1.5 W/ft<sup>2</sup> (16 W/m<sup>2</sup>) depending on the specific tasks to be performed. A minimum of 0.1 W/ft<sup>2</sup> (1 W/m<sup>2</sup>) for auditoriums to a maximum of 2.5 W/ft<sup>2</sup> (27 W/m<sup>2</sup>) for machine shops is possible, although the upper limit would occur very rarely. Mechanical spaces in building storage areas and similar spaces in which outlets are provided but infrequently used are usually neglected in computing loads, except for special cases.

2.2.1.2 Electric Power Loads. Electric power loads shall include all loads other than lighting loads and those served by general purpose receptacles and comprise the environmental system electric power requirements and the facility occupancy equipment electric power requirements.

2.2.1.3 System Loss. A system loss of approximately 6 percent, based on calculated maximum demand, should be added to the building load.

2.2.2 Demand and Load Factors. The demand and load factors for a specific facility will vary with the division of load and hours of usage. Refer to Tables 2 and 3 for values that can be applied to determine demand and load factors. Table 4 is included as a guide and an aid in illustrating the method of determining loads, which are calculated for a particular type of building, such as an academic and general instruction building (Navy Code 171-10). The values given are empirical and will vary from activity to activity, and may vary from one facility to another within an activity. Annual hours use of demand must be determined for each case in accordance with methods of operation and characteristics of the installation. Demand factors and load factors for individual facilities by the Navy category code given in Table 1 are based on a survey of existing Navy facilities and past experience. Such factors should be used for quick estimating purposes and as a check when a more precise calculation is undertaken (refer to Table 4).

2.2.2.1 Guides for Demand Factors. For guides on the selection of demand factors, refer to Table 5.

2.2.2.2 Guides for Load Factors. Guides for the selection of load factors indicate the need for special considerations (refer to Table 6). Factors in the middle of the range are for the average facility at the peacetime shore establishment and should be used unless the guides in Table 6 indicate otherwise.

2.2.3 Load Growth. Determine the requirements for load growth for anticipated usage and life expectancy with particular attention to the possibility of adding heavy loads in the form of air conditioning, electric heating, electric data processing, and electronic communication equipment. Before determining the size of service and method of distribution to a facility, an economic analysis shall be made to determine the most feasible way of serving this future load. This analysis shall include the effect on the existing installation if future loads require reinforcing or rehabilitation of the service system.

Table 2  
Demand Factors for Specific Loads (See Note 1)

TYPES OF LOADS	ESTIMATED	QUICK
	RANGE OF DEMAND FACTOR (%)	ESTIMATING DEMAND FACTOR (%)
MOTORS:		
General purpose, machine tool, cranes, elevators, ventilation, compressors, pumps, etc. ....	20 - 100	30
MOTORS:		
Miscellaneous, fractional, and small appliances .....	10 - 50	25
Resistance ovens, heaters, and furnaces ....	80 - 100	80
Induction furnaces .....	80 - 100	80
Lighting .....	65 - 100	75
Arc welders .....	25 - 50	30
Resistance welders .....	5 - 40	20
Air-conditioning equipment .....	60 - 100	70
Refrigeration compressors .....	40 - 100	60

Note 1: Demand factors include allowance for system loss.

Table 3  
Annual Hours of Demand Usage for Specific Loads

TYPES OF LOADS	QUICK ESTIMATING HOURS USE		
	1-SHIFT OPERATION	2-SHIFT OPERATION	3-SHIFT OPERATION
MOTORS:			
General purpose .....	1,200	1,600	2,000
MOTORS:			
Miscellaneous, fractional, and small appliances .....	1,500	1,800	2,100
Resistance ovens, heaters, and furnaces .	1,000	1,300	1,600
Induction furnaces .....	900	1,200	1,500
Lighting .....	2,200	2,800	3,500
Arc welders .....	500	700	900
Resistance welders .....	500	700	900
Air-conditioning equipment			
Less than 1,500 cooling degree days ...	1,200	1,400	1,600
1,500 to 1,500 cooling degree days ....	1,600	1,800	2,000
More than 2,500 cooling degree days ...	2,200	2,500	2,800

Table 4  
Academic Building (Code 171-10) Demand and Load Factor Calculations  
(See Note 1)

	MOTORS					TOTAL
	GENERAL	MISCEL- LANEOUS FRAC- TIONAL & SMALL APPLI- ANCES	LIGHTING	AIR CONDI- TIONING		
1. Watts/square foot	1.0	1.0	2.7	4.5		9.2
(Watts/square meter)	10	10	26.5	45		91.5
2. Connected load	100 kw	100 kw	265 kw	450 kw		915 kw
3. Specific load demand factor	30%	10%	75%	70%		
4. Maximum demand load (line 2 X line 3)	30 kw	10 kw	200 kw	315 kw		555 kw
5. Annual operating (1-shift) usage	1,200 hrs	1,500 hrs	2,200 hrs	1600 hrs		
6. Annual usage in megawatt hours (line 4 X line 5)	36	15	440	504		995
7. Demand factor line 4 Formula = $\frac{\text{line 4}}{\text{(1) line 2}}$	—	—	—	—		60%
8. Load factor line 6 Formula = $\frac{\text{line 6}}{\text{(4) line 4 X 8760 hrs}}$	—	—	—	—		20%

Note 1: Calculated for a 100,000 square-foot (10,000 square meter) building. See tables 2 and 3 for data used for lines 3 and 5 respectively. Load growth is included in connected load. Maximum demand load includes allowance for system loss. For this illustration, the coincidence factor occurring when individual demand loads are added is considered to be 1.00 and has not been shown.

Table 5  
Guides for Selection of Demand Factors

Selection of factors in upper half of range for conditions described below	Selection of factors in lower half of range for conditions described below
GENERAL GUIDES	
Facilities in active use and approaching maximum capacity. Loads predominantly lighting. Loads predominantly heating. Loads dominated by one or two large motors.	Facilities of intermittent use or not being fully utilized. Motor loads made up of a number of independently operated small motors. Motor loads controlled automatically unless control depends upon weather conditions.
OPERATIONAL AND TRAINING FACILITIES	
Instruction buildings with little or no electric equipment. Communications buildings with telephonic equipment only.	Large instruction buildings with electrical demonstration and training equipment.
MAINTENANCE AND PRODUCTION FACILITIES	
Shops and facilities when engaged in mass production of similar parts.	No special guides.
RESEARCH, DEVELOPMENT, AND TEST FACILITIES	
Facilities used for repetitive testing of material or equipment.	No special guides.
SUPPLY FACILITIES	
Refrigerated warehouses in South. Dehumidified warehouses in Mississippi Valley and along seacoasts. Warehouses for active storage.	Warehouses with many items of electric materials handling equipment, including cranes and elevators.
HOSPITAL AND MEDICAL FACILITIES	
No special guides.	No special guides.

Table 5 (Continued)  
 Guides for Selection of Demand Factors

---

ADMINISTRATIVE FACILITIES

---

Large administrative buildings with mechanical ventilation and air conditioning.

Note: Group large administrative buildings separately only when administration is a significant part of total activity load.

Casual offices, offices used infrequently by foremen and supervisors, or offices in which there is little prolonged desk work.

---

HOUSING AND COMMUNITY FACILITIES

---

Enlisted barracks at training centers. Public quarters where less than 25 family units are involved.

Food service facilities where load is primarily cooking and baking.

Restaurants, exchanges, cafeterias, and other food service facilities when gas or steam is primary fuel.

---

UTILITIES AND GROUND IMPROVEMENTS

---

Central heating plants serving extended areas and buildings.

Water pumping stations serving extended areas or carrying most of load of water systems.

Central station compressed air plants.

---

No special guides.

Table 6  
Guides for Selection of Loads Factors

Select factors in upper half of range  
conditions described below

Select factors in lower half of  
range for conditions described below

---

GENERAL GUIDES

---

Facilities operated on two or more shifts.  
Loads that are primarily fluorescent or high intensity discharge lighting.  
Many small independently operated motors.  
Electronic equipment continuously operated for immediate use.  
Cooling and dehumidification loads for year-round climate control in southern climates.  
Retail-type service loads and loads that are in active use.

Facilities used intermittently.  
Inactive facilities.  
Large motor loads when the load consists of relatively small numbers of motors.  
Wholesale-type service facilities.

---

OPERATIONAL AND TRAINING FACILITIES

---

Large, permanent instruction buildings in active use.

Special-purpose instruction and training facilities not regularly used.

---

MAINTENANCE AND PRODUCTION FACILITIES

---

Shops with battery charging equipment operated after hours.  
Active shops at full employment.  
Mass production shops.

Welding loads or loads made up primarily of welding equipment.  
Job-order workshops.  
Shops with large, heavy special function machines.  
Large induction or dielectric heating loads.

---

RESEARCH, DEVELOPMENT, AND TEST FACILITIES

---

No special guides.

No special guides.

---

Table 6 (Continued)  
Guides for Selection of Loads Factors

---

SUPPLY FACILITIES

---

Refrigerated and dehumidified warehouses in South or in humid climates. Warehouses for active storage and in continuous use.	Refrigerated warehouses in North. Warehouses with large materials handling equipment loads.
---	---

---

HOSPITAL AND MEDICAL FACILITIES

---

Clinics and wards with daily operating hours and in active use.	No special guides.
---	--------------------

---

ADMINISTRATIVE FACILITIES

---

Large, active, well-lighted offices with ventilation and air-conditioning equipment.	No special guides.
--	--------------------

---

HOUSING AND COMMUNITY FACILITIES

---

Navy exchanges with food service facilities. Gymnasiums used in connection or with physical therapy. Barracks at schools and training centers.	Restaurants and exchanges serving only one meal a day. Restaurants and exchanges with gas steam food preparation equipment. Chapels used primarily on Sundays. Subsistence buildings serving less than four meals a day. Laundries with dry cleaning plants. Exchanges operated less than 8 hrs/day. Gatehouses operated less than 24 hrs/day.
--	--

---

UTILITIES AND GROUND IMPROVEMENTS

---

Heating plants that supply both heating and process steam. Water plants with little power load. Air-conditioning plants for year-round control of environment in South. Compressed air plants consisting of many banked compressors operating automatically.	Heating plants in South.
---	--------------------------

---



2.2.4 Emergency Loads. The determination of emergency electric power requirements is based on three types of loads (refer to Section 3 for types of loads to be included in each category):

- a) minimum essential load,
- b) emergency load for vital operations, and
- c) uninterruptible (no-break) load.

When the three categories of emergency electric power requirements have been ascertained, determine where local emergency facilities are required, where loads may be grouped for centralized emergency facilities, and what loads are satisfied by the reliability of the general system. Base the aforementioned determinations on safety, reliability, and economy, in that order.

2.3 Area Loads. Area loads consist of groups of individual facility loads served by a subdivision of the electric distribution system. The term "area" applies to the next larger subdivision of an overall distribution system. Demand loads for an area must be known for sizing the distribution wiring and switching, and in a large installation will be required for the design of substations serving the area. Table 7 gives an example of how the coincident peak demand is calculated.

2.3.1 General Loads. To obtain the general load, add roadway lighting, area lighting, obstruction lighting, and other loads not included in individual facility loads.

2.3.2 Coincidence Factor. Determine the maximum expected demands, taking into consideration whether loads within the area peak at the same or at different times.

2.3.2.1 Relationships. Figure 1 indicates the relationship that exists between the load factor of individual facility loads and the coincidence of their peak demands with the peak demand of the group. This relationship was developed by a study of the loads of selected naval shore activities and by the application of factors developed to the formulas published by the Institute of Electrical and Electronic Engineers (IEEE). For collateral reading on this subject, refer to IEEE Technical Paper 45-116 Coincidence-Factor Relationship of Electric Service Load Characteristics. Table 8 is Figure 1 in tabular form with values shown to the nearest whole dollar, except for low load factors.

2.3.2.2 Selection. Areas with relatively insignificant residential type loads, where the load curve indicates that most of the electric power consumed in the area is used during the 40 normal working hours of a week, have coincidence factors at the higher end of the range.

2.3.2.3 Electric Power Consumption. In general, areas where large amounts of electric power are consumed outside the usual 40 working hours a week have a coincidence factor at the lower end of the range (examples are hospitals, areas operated on two or more shifts, or large barracks type activities). The upper limit of the range is for a 40 hour per week operation; the lower limit is for a 60 hour per week operation.

Table 7  
Method of Calculating Coincident Peak Demand  
Parenthesized () numbers refer to Notes

NAVY CODE	DESCRIPTION	TOTAL CONNECT- ED LOAD  (kW)	DEMND FACT- OR  (%)	MAXIMUM DEMAND  (%)	LOAD FAC- TOR  (%)	COIN- CID- ENCE FAC- TOR  (%)	COIN- CID- ENCE PEAK  (kW)
125 16	Fuel oil pump house.....						
125 16	Fuel oil pump house.....						
125 16	Total	0.3	100	0.3	52	52(1)	0.2
125 20	Filling station .....	3.0	60	1.8	18	57(1)	1.0
125 20	Filling station bldg .	0.3	80	0.2	20	61(1)	0.1
131 35	Receiver building	2.1	65	1.4	72	79	1.1
131 50	Transmitter building.....						
131 50	Transmitter building.....						
131 50	Total .....	37.2	65	24.2	72	79	19.1
133 25	Tacan building .....	0.7	65	0.5	72	79	0.4
133 75	Radar building .....	1.2	70	0.8	72	79	0.6
141 20	Aircraft fire and rescue station .....	8.0	30	2.4	15	52(1)	1.2
141 40	Aircraft operations building .....	80.2	80	64.2	28	68(1)	43.6
141 60	Photographic building	10.5	70	7.4	18	57(1)	4.2
171 10	Academic instruc. bldg.....						
171 10	Academic instruc. bldg.....						
171 10	Academic instruc. bldg.....						
171 10	Academic instruc. bldg.....						
171 10	Total	47	60	28.2	22	62(1)	17.5
171 35	Operational Trainer facility .....	0.1	80	0.1	15	52(1)	....
211 10	Aircraft overhaul and repair shop ....	7,600	38	2,890	25	95(2)	2,745
211 12	Paint/finishing hangar	127	70	89.0	26	66(1)	58.3
211 22	Engine preparation and storage shop.....						
211 21	Engine maint. shop.....						
211 21	Engine maint. shop.....						
211 21	Total .....	405	40	162	15	52(1)	84.2
211 83	Engine test cell .....	360	45	162	28	68(1)	110
212 20	Missile equipment maint. shop .....	3.0	40	1.2	22	62(1)	0.7
214 20	Auto veh. maint. facs.....						
214 20	Auto veh. maint. facs.....						
214 20	Auto veh. maint. facs.....						
214 20	Auto veh. maint. facs.....						
214 20	Total	370	60	222	25	65(1)	145

Table 7 (Continued)  
Method of Calculating Coincident Peak Demand

730	10	Fire station .....	14.6	30	4.4	15	521	2.3
							Total	3,325
							System loss (6%)	194
							Grand total	3,429

- (1) The coincidence factor has been increased to allow for low load factor and number of facilities in the area. Refer to para. 2.3.2.4, Influencing Factors, of this handbook.
- (2) The coincidence factor has been increased because of the relative magnitude of the load. Refer to para. 2.3.2.5, Individual Loads, of this handbook.

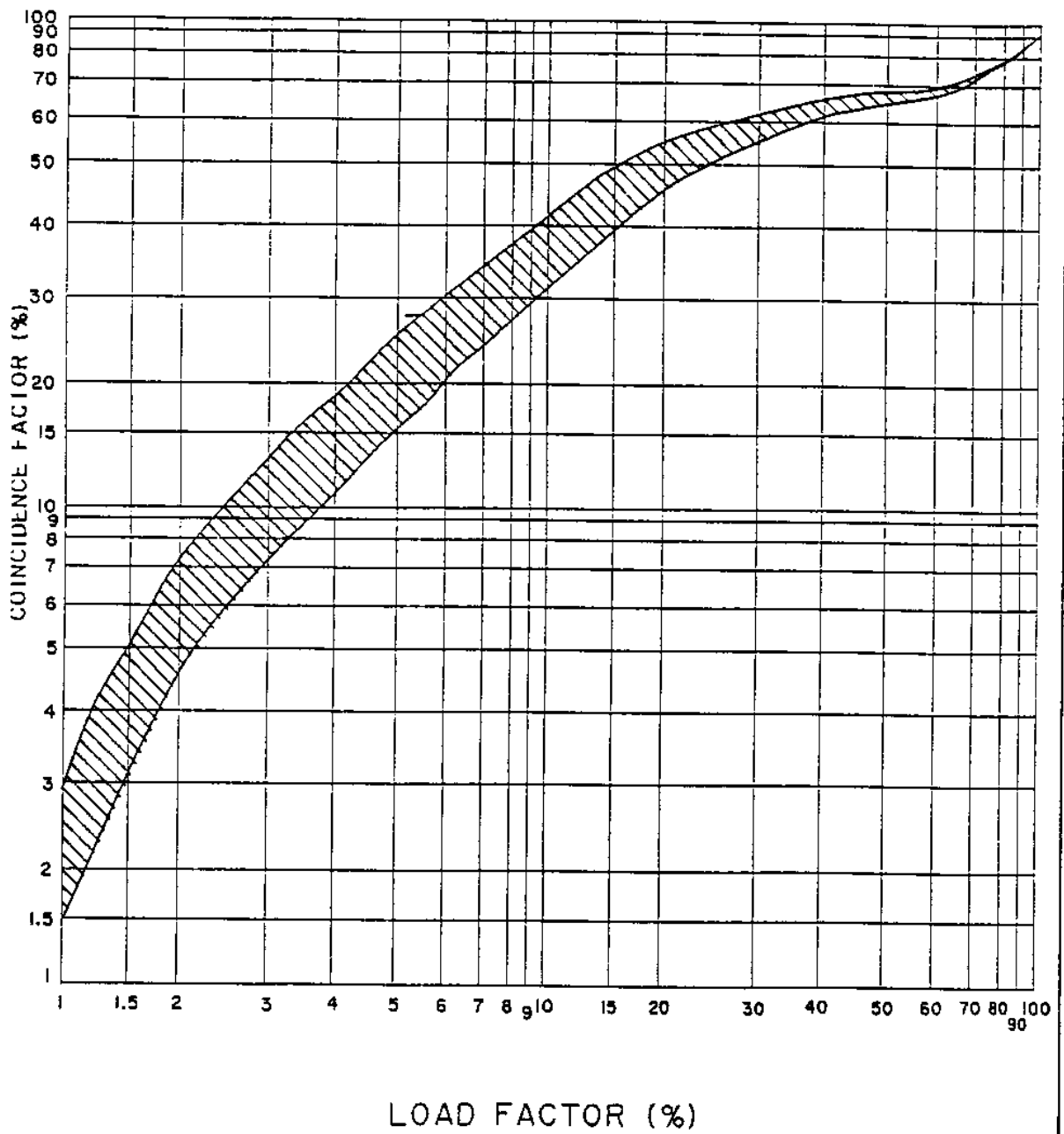

**Figure 1**  
**Theoretical Relationship Between Load Factor and Coincidence**  
**Factor at U.S. Naval Shore Establishments**

Table 8  
Relationship Between Load Factor and Coincidence Factor

LOAD FACTOR (%)	COINCIDENCE FACTOR (%)		LOAD FACTOR (%)	COINCIDENCE FACTOR (%)	
	Loads (hr/wk)			LOADS (hr/wk)	
	40	60		40	60
1	2.5	1.5	51	73	69
2	7.5	4.5	52	73	70
3	12	8	53	73	70
4	17	11	54	73	70
5	21	14	55	73	71
6	25	17	56	73	71
7	28	20	57	73	71
8	32	22	58	74	71
9	35	24	59	74	72
10	38	26	60	74	72
11	41	29	61	74	72
12	44	32	62	75	73
13	46	34	63	75	73
14	49	36	64	76	74
15	51	38	65	76	74
16	53	40	66	77	75
17	54	42	67	77	75
18	56	44	68	78	76
19	57	46	69	78	76
20	59	48	70	78	77
21	60	50	71	78	77
22	61	51	72	79	78
23	62	53	73	79	78
24	63	54	74	80	79
25	64	55	75	81	80
26	65	56	76	81	80
27	66	56	77	82	81
28	67	57	78	82	81
29	68	58	79	82	81
30	69	59	80	82	82
31	69	60	81	82	82
32	69	61	82	82	82
33	70	62	83	83	83
34	70	63	84	84	84
35	71	64	85	85	85
36	71	64	86	86	86
37	71	65	87	87	87
38	71	65	88	88	88
39	72	65	89	89	89
40	72	66	90	90	90
41	72	66	91	91	91
42	72	66	92	92	92
43	72	67	93	93	93

Table 8 (Continued)  
 Relationship Between Load Factor and Coincidence Factor

LOAD FACTOR (%)	COINCIDENCE FACTOR (%)		LOAD FACTOR (%)	COINCIDENCE FACTOR (%)	
	Loads (hr/wk)			LOADS (hr/wk)	
	40	60		40	60
44	73	67	94	94	94
45	73	67	95	95	95
46	73	67	96	96	96
47	73	68	97	97	97
48	73	68	98	98	98
49	73	69	99	99	99
50	73	69	100	100	100

2.3.2.4 Influencing Factors. The number of individual loads in a group and their load factors influence the individual load coincidence factor. The coincidence factors in Table 8 apply for groups of 100 or more individual loads. These coincidence factors can also be used for groups of as few as 30 to 50 individual loads if their load factor is 0.30 or greater. For areas of fewer individual loads, the mathematical relationship from IEEE Technical Paper 45-116 provides a basis for estimating the connected coincidence factor as shown by the following equation:

$$\text{EQUATION: } E_n = E_t + (1-E_t) 1/n \quad (5)$$

Where:

$E_n$  = The individual load coincidence factor applied with a given number of consumers

$E_t$  = the coincidence factor as given in Table 8 in hundredths.

$n$  = the number of individual loads in a group.

2.3.2.5 Individual Loads. The coincidence factors in Table 8 are based on the individual loads in a group being substantially the same size. If a single load or small group of loads in an area represents a substantial percentage of overall load, the coincidence factors as given in Table 8 will no longer apply. With an individual load, increase the coincidence factor to a value commensurate with its effect on the overall area load. This is not in addition to, but in place of, the normal coincidence factor. Determine this value by considering intergroup coincidence factors given in paragraph

2.3.2.6. (An example of facility Navy code 211-70 is presented in Table 7.) For a small group, determine the coincidence peak load, and to this apply the appropriate intergroup coincidence factor to obtain the coincidence peak load for the area.

2.3.2.6 Groups of Loads or Areas. Where groups of loads within an area, or areas within a facility are combined, an additional intergroup coincidence factor will exist. For loads of a similar nature, the intergroup coincidence factor should be in the range 0.93 to 1.00. If loads of a varying nature (evening loads and daytime loads) are combined, the intergroup coincidence factor should be in the range of 0.70 to 1.00. The lower values will occur when the magnitudes of the loads are nearly balanced, and the higher ones when the combined load is predominantly one type.

2.3.3 Load growth. In addition to planned expansion, increased application of electric equipment will generate an increase in load. When sizing components, such as transformers or feeders for the area system, consider possible load growth in addition to that included in the determination of individual loads.

2.3.4 System Losses. Add distribution system losses to estimated area demands. For a good approximation, use 6 percent of the calculated maximum demand.

2.3.5 Emergency Loads. Review the overall emergency requirements for the area, based on criteria for the facility or as furnished by the using agency, to determine the following:

a) The emergency loads that may be combined in groups to take advantage of the coincidence factor.

b) The type of distribution system needed for reliability and to economically satisfy at least the less critical emergency load requirements. This reliability can be provided only if the source of electric power is not the determining factor.

c) Area loads that must be added to individual emergency loads; for example, security lighting and minimum roadway lighting.

2.3.6 Expansion. The planned development of the area, as shown on the activity general development map, shall be considered for requirements of future expansion.

2.4 Activity Loads. Activity loads are loads that consist of two or more area loads served from a single electric power source and an integrated distribution system.

2.4.1 General Loads. Follow the approach used in para. 2.3 for area loads. Area loads used for determining activity coincidence demand should be the area coincident demand exclusive of allowance for load growth.

2.4.2 Coincidence Factor. Refer to para. 2.3.2 for the necessary approach. Where dissimilar areas, whether residential, administrative, or industrial, are part of an activity, make a careful analysis of the coincidence factor used.

2.4.3 Load Growth. As for an area, components should be sized after due consideration has been given to load growth. Apply this increase to the coincident demand of the activity.

2.4.4 Expansion. The planned development of the activity, as shown on its general development map, shall be considered for requirements of future expansion.



## Section 3: SELECTION OF ELECTRIC POWER SOURCE

3.1 Policy. In electric power source selection, use the same criteria employed for selection of electric power plants in NAVFAC DM-3, Mechanical Engineering Series.

3.2 Economic Factors. Use the same criteria presented for economic studies of electric generating plants in the NAVFAC DM-3 Series.

3.3 Electric Power Sources. The electric power supply for a major shore activity usually will consist of three sources: primary, standby, and emergency (alternate). In addition, some operations cannot tolerate any electric power interruption, thus requiring uninterruptible power supply (UPS) systems. MIL-HDBK-1190 Facility Planning and Design Guide, Chapter 7 under "Alternate Power Sources," indicates systems and functions authorized to have alternate power sources and provides design criteria for such alternate sources.

3.3.1 Primary. The primary or preferred source should have sufficient capacity to provide for peak electric power demand during normal peacetime operations.

3.3.2 Standby. The standby source should have enough capacity so that the standby system can supply all of the minimum essential operating electric load of the activity and, when added to the capacity of the primary source, will provide a combined capacity sufficient to serve the estimated peak demand under mobilization conditions. This "minimum essential operating electric load" is the minimum electric power necessary to support the absolutely essential operations of the activity, with illumination reduced to a bare minimum and with all convenience loads and other loads (such as hospital elevators, except the minimum required for patient and food transportation) suspended. Where major intermittent loads, such as drydock pumping, electric furnaces, electric welders, and wind tunnels, are involved, it is necessary to determine whether concurrent operation of such equipment can be avoided.

3.3.3 Emergency. The emergency sources, usually one or more engine-driven, manual, or automatic-starting emergency generators, should have sufficient total capacity to provide the electric power demand for vital operations. Vital operations are those that can tolerate electric power interruption only for relatively short durations. For certain operations, the permissible electric power interruption is as long as 4 hours, for others it is only 10 seconds. The latter condition will require automatic start but the former condition may be manual start. The emergency source should be of sufficient capacity to provide a continuous and adequate supply for vital operations, but should be planned to bear a sound relation to the standby service provided. Vital operations will normally be in two categories:

- a) Operations recognized by local, state, or national codes, and
- b) Operations determined as vital by the major claimant or user.

To qualify as a vital operation, the electric power outages must cause loss of

primary missions, thus resulting in disastrous situations or extreme safety hazards as compared to minor disruption and inconvenience. Such vital operations may include, but are not necessarily limited to, communications, ventilation, and lighting of combat operations centers, personnel bomb shelters, anti-aircraft, harbor defenses, industrial processes that might cause explosion if interrupted, hospital surgeries, blood banks, bone banks, iron lungs, and similar operations.

3.3.4 Uninterruptible (No-Break) Electric Power. An Uninterruptible Power Supply (UPS) system is necessary for certain electronic or other equipment that perform a critical functions and require continuous, disturbance-free electric power to operate properly. This electric power system must, under all conditions, provide regulated electric power to the critical load.

3.4 Acceptable Electric Power Sources. Electric power sources acceptable for supplying shore facilities are given in paras. 3.4.1 through 3.4.4.

3.4.1 Primary. The primary source of electric power may be navy-owned generating equipment or one or more feeders from an outside electric power system.

3.4.2 Standby. Where the primary source of electric power is Navy-owned generation, the standby source may be other Navy-owned generation or service supplied over a feeder, or feeders, from an outside electric power supplier. Where the primary source of electric power is from an outside electric power supplier, the standby source may be Navy-owned generation or service supplied over a feeder, or feeders, from a different outside electric power supplier or supply from an alternate feeder from the same outside electric power supplier. The alternate feeder must be located at some distance from the normal feeder, and supplied independently of the substation and generating source of the normal feeder. Where this is not feasible, a supply from transmission lines or substations of the outside electric power supplier, which themselves have dual supplies, is an acceptable alternative.

3.4.3 Emergency. Permanently installed, mobile or semimobile, manual or automatic starting generating equipment should be provided to supply emergency electric power. Emergency generating capacity should not exceed the minimum required to supply electric power for vital operations, and should be located as close to those loads as practicable. Provisions for normal load growth (15 to 20 percent spare capacity) shall be provided. As a minimum, the provisions of NFPA 110 Emergency and Standby Power Systems, shall apply.

3.4.4 Uninterruptible (No-Break) Electric Power. Permanently installed, automatically operated equipment should be provided to supply uninterruptible electric power. Equipment capacity should not exceed the minimum required to supply electric power for critical loads, and equipment should be located as close to these loads as practicable. Provision for normal load growth (15 to 20 percent spare capacity) shall be provided.

3.5 Purchased Electric Power Requirements. In the selection of private utility electric power supplies consider the factors in paras. 3.5.1 through 3.5.5.

3.5.1 Adequacy. Determine the capability of the electric utility company to furnish electric power, of the required characteristics, to meet the immediate estimated demand. The capability of the utility to meet the demand under mobilization conditions should be determined on the best basis available. Ascertain whether or not the utility has enough construction in its program to meet the loads anticipated for the next 5 years.

3.5.2 Reliability. Investigate the history of outages of the contemplated utility company to determine if it can provide the degree of reliability required by the particular installation. The investigation shall include the following items:

- a) A 5-year history of service outages in the area, including:
  - (1) The time and date of each occurrence
  - (2) Duration, time, and date of each restoration
  - (3) Cause
  - (4) Steps taken to restore service and
  - (5) A probability analysis showing the expected number of outages of 1 minute, 5 minutes, 10 minutes, 30 minutes, and 60 minutes.
- b) A one-line diagram of the supplier's system, showing the location of all switching equipment, circuit breakers, relaying, and similar components.
- c) A short circuit study of the system, including interrupting capacities of all switching equipment, time constants, and short circuit currents for both existing and expanded facilities in the area.
- d) Voltage regulation, nominal voltage, and normal operating voltage of supplier's facilities.
- e) Climatic and other physical conditions prevailing in the area and on the system that may affect the reliability of service. Some utilities will only supply a minimum of data for items a) to c), and evaluation may be necessary using data available from other military installations in the area.

3.5.3 Rates. To take advantage of the lowest available cost of electric energy, compare electric energy rates with estimated maximum demand and consumption. Compare the estimated demand block with prices per kilowatt-hour of other customers served by the same utility company. Choice of either primary or secondary connection shall be based on selection of connection charges and rental of company equipment that provide the maximum advantage to the Government. An analysis of rates shall be based on the company's complete tariff covering all types of services. This review will entail comparison of several tariffs that are available on an alternative basis, as well as the Contractor's general rules and regulations that modify the tariffs.

3.5.4 Primary Service Right-of-Way. The supply company should provide the right-of-way for all of its electric lines up to the Government property (refer to MIL-HDBK-1004/2, Power Distribution Systems).

### 3.5.5 Primary Substations

3.5.5.1 Voltage. A substation may not be required where the utility company serves energy at 13.8 kV or less; distribution may be at this voltage. In some cases, if the loads are large enough, distribution may be done at higher voltage up to a maximum of 35 kV. Refer to Section 6 for information on levels of distribution voltage, and MIL-HDBK-1004/2 for data on substations.

3.5.5.2 Economics. Usually, ownership of main substations serving an activity is determined by engineering and economic factors. Distribution system voltages, as well as amortization costs of substations, should be the controlling factors.

## Section 4: UNINTERRUPTIBLE POWER SYSTEMS

4.1 Requirements. Uninterruptible power system (UPS) will use centrally-procured Government-Furnished Equipment (GFE). GFE includes the UPS module and the UPS battery. The emergency generator is not normally included as part of the GFE. Procurement of this equipment is beyond the scope of this handbook. However, the installation of such equipment in conjunction with auxiliary systems must be properly designed, which requires an understanding of the specialized equipment and concepts involved. This section covers the equipment installation criteria which, when integrated with the individual project requirements, shall produce a safe, reliable, and cost efficient design.

4.2 Criteria. The latest issues of the following documents shall be used to ensure correct installation of the GFE equipment:

SUBJECT	SOURCE
UPS Module.....	Manufacturer's installation instructions
Battery.....	Manufacturer's installation instructions
Emergency Power.....	IEEE 446, Recommended Practice for Emergency Standby Power Systems and DM-12.1, Electronic Facilities Engineering
Environmental considerations (mechanical design).....	DM-3 and DM-12.1

4.3 Power Load Categories. Power load categories are illustrated in Figure 4 of DM-12.1. The pertinent categories, listed below, are defined in DM-12.1:

- a) Station load
- b) Nonoperational load
- c) Operational load
- d) Utility load ("nontechnical load")
- e) Electronic load ("technical load")
- f) Noncritical electronic load ("noncritical technical load")
- g) Critical electronic load ("critical technical load")

#### 4.4 Definitions. The following definitions of terms shall apply:

a) Uninterruptible Power Supply System - An uninterruptible power supply system consists of UPS equipment, backup power source(s), environmental equipment, switchgear, and controls which together provide a reliable, continuous quality electric power system.

b) Critical Electronic Load - The critical electronic load is that part of the load that requires continuous quality electric power for its successful operation.

c) Uninterruptible Power Supply (UPS) - An uninterruptible power supply (UPS) consists of one or more UPS modules, an energy storage battery, and accessories as required to provide a reliable and high quality power supply. The UPS isolates the load from the primary and emergency power sources and, in the event of a power interruption, provides regulated power to the critical load for a specified period depending on the battery capacity. The battery normally has a 15-minute capacity when operating at full load.

d) UPS Module - A UPS module is the static power conversion portion of the UPS system and consists of a rectifier, an inverter, and associated controls along with synchronizing, protective, and auxiliary devices. UPS modules may be designed to operate either individually or in parallel.

e) Nonredundant UPS Configuration. The nonredundant UPS configuration consists of one UPS module with a static bypass circuit and a battery, and a maintenance bypass cabinet. Upon failure of the UPS module, the static bypass circuit automatically transfers the critical electronic load to the primary or emergency source without an interruption to the load (see Figure 2).

f) "Cold" Standby Redundant UPS Configuration. The "cold" standby redundant UPS configuration consists of two independent nonredundant UPS modules with a common battery. One UPS module operates on the line, and the other UPS module is turned off. Should the operating UPS module fail, its static bypass circuit will automatically transfer the critical electronic load to the primary or emergency source without an interruption to the critical load. The second UPS module is then manually energized and placed in the bypass mode of operation. To transfer the critical load, external make-before-break nonautomatic circuit breakers (or contactors) are operated to place the load on the second UPS bypass circuit. Finally, the critical electronic load is returned from the bypass to the second UPS module via the static switch. The two UPS modules cannot operate in parallel; therefore, an interlock circuit must be provided to prevent this condition (see Figure 3). UPS modules are to be transferred to and from "cold" standby every three months. The mode of operation is as follows:

(1) Transfer Circuit Interlock, External Bypass - The two circuit breakers (or contactors) shall be nonautomatic and motor operated. Transfer to and from one UPS to the other shall be a closed circuit (make-before-break) transition and shall be possible only when both UPS's are in the bypass mode of operation.

(2) Transfer Circuit Operation - To transfer critical load from UPS module No. 1 to UPS module No. 2, both modules are placed in the bypass mode. The make-before-break nonautomatic circuit breakers are operated to transfer the critical load to the bypass circuit of UPS module No. 2, after

MIL-HDBK-1004/1

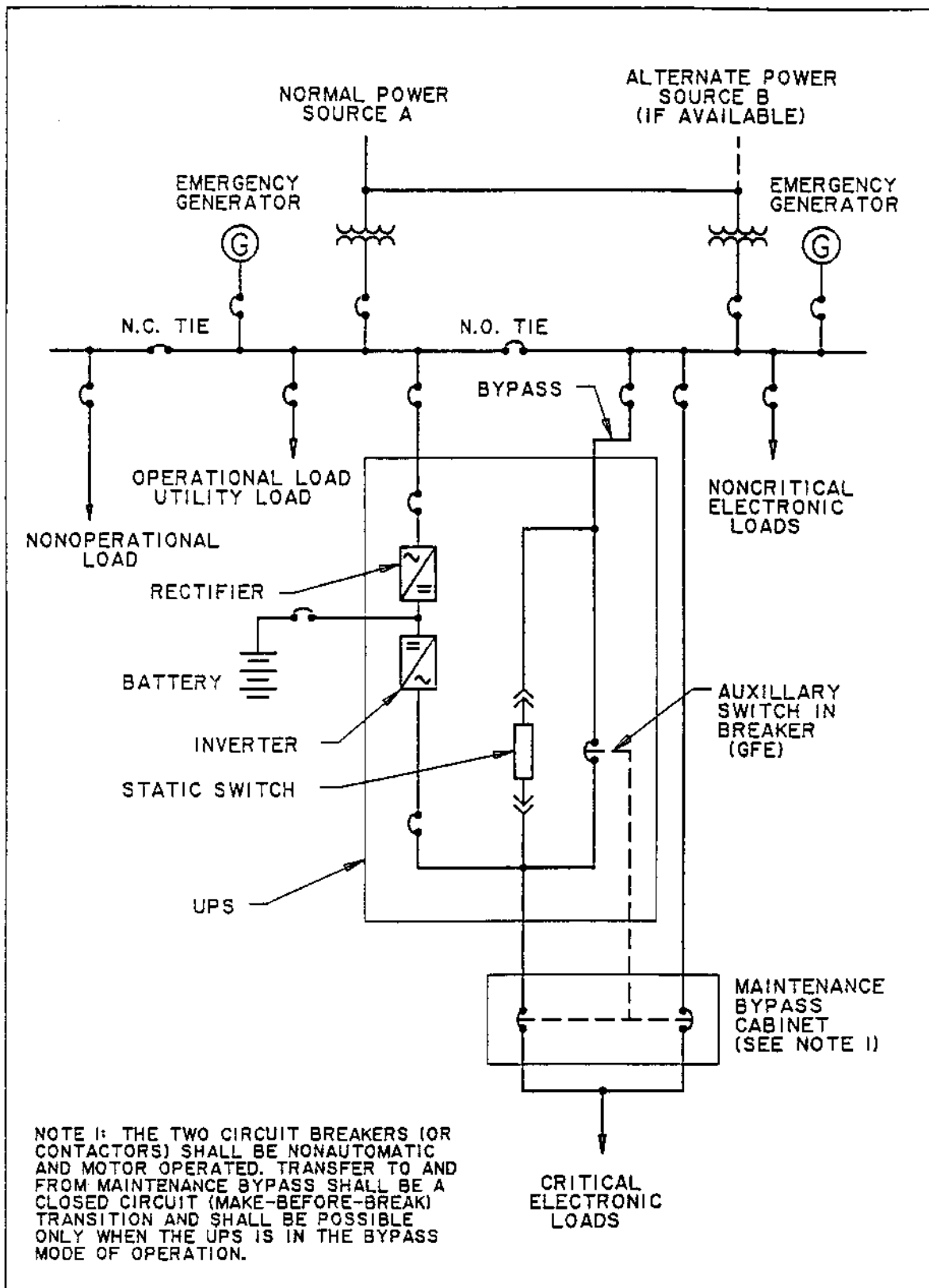

**Figure 2**  
**Typical Nonredundant Configuration**



MIL-HDBK-1004/1

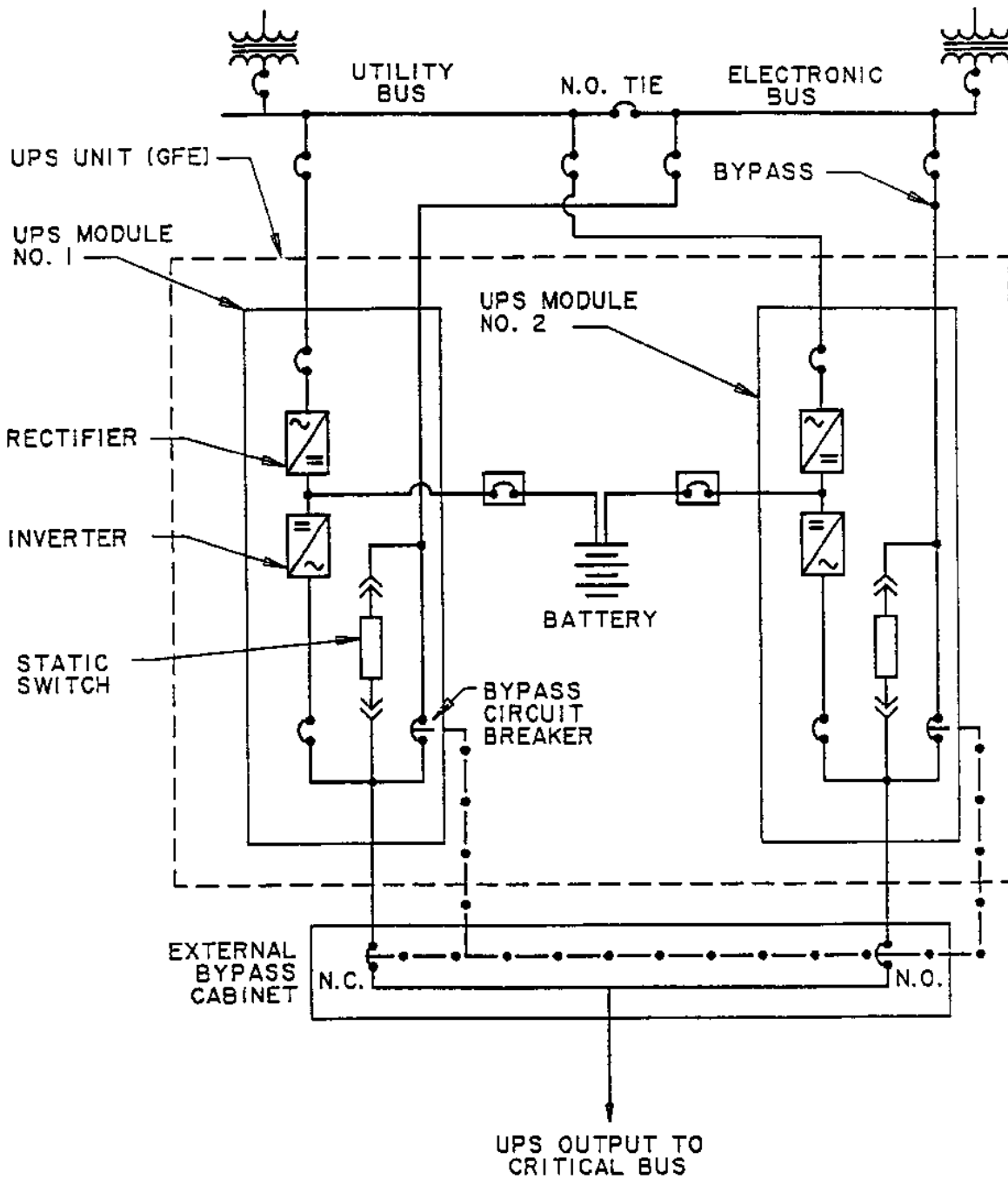

Figure 3  
Typical "Cold" Standby Redundant Configuration (UPS)

which the critical load is transferred to supply the inverter output. UPS module No. 1 can then be completely isolated for maintenance or repair.

g) Parallel Redundant UPS Configuration. A parallel redundant UPS configuration consists of two or more UPS modules with a system control cabinet and a common battery. UPS modules operate in parallel, and the system is capable of supplying the rated critical load upon failure of any one UPS module. The failed UPS module will be disconnected from other UPS modules without an interruption to the critical load (see Figure 4).

4.5 Redundancy. For facilities requiring UPS systems, a nonredundant UPS system is satisfactory for most operations. The justification for the added expense of either redundant system is given in paras 4.5.1 and 4.5.2.

4.5.1 "Cold" Standby Redundant UPS System. Provide a "cold" standby redundant UPS system when the installation site is isolated and logistic support is poor or when the primary electric power supply exhibits poor reliability by experiencing more than four power interruptions per month or when the primary electric power supply provides voltage or frequency fluctuations which are beyond the limits permitted in MIL-HDBK-411, Long Haul Communications (DCA) Power and Environmental Control for Physical Plant.

4.5.2 Parallel Redundant UPS System. Provide a parallel redundant UPS system when the frequency of the primary electric power supply must be converted to serve the critical load (that is, 50 Hz to 60 Hz, or 60 Hz to 400 Hz).

4.6 Electric Service and Bypass Connectors. Two separate electric services, one to the UPS rectifier circuit and the other to the UPS bypass circuit shall be provided. Where possible, they shall emanate from two separate buses with the UPS bypass connected to the electronic (noncyclic) bus and the rectifier connected to the utility (cyclic) bus. This connection provides isolation of sensitive electronic loads from the effects of UPS rectifier harmonic distortion and motor startup current inrush.

4.6.1 Electric Service Size. A UPS system is considered to be a continuous type load, and service to both the rectifier and bypass circuits should be sized in accordance with article 220 of the National Electric Code. The required current for the rectifier circuit is calculated based on the UPS output rating divided by the UPS efficiency and multiplied by a load factor of 125 percent to take into account battery charging. The UPS bypass circuit may be rated for less current since both UPS losses and battery charging requirements need not be supplied.

4.6.2 Maintenance Bypass Provisions. To provide for maintenance of equipment, bypass provisions are provided as follows:

a) For the non-redundant UPS unit, install an external bypass switch in order to completely isolate the UPS unit (see Figure 2). This is to enable testing of the UPS unit, including the static switch, with dummy load without interruption to the critical bus.

b) Each module of the "cold" standby redundant UPS has the same built-in bypass circuit provisions as the nonredundant UPS. Complete

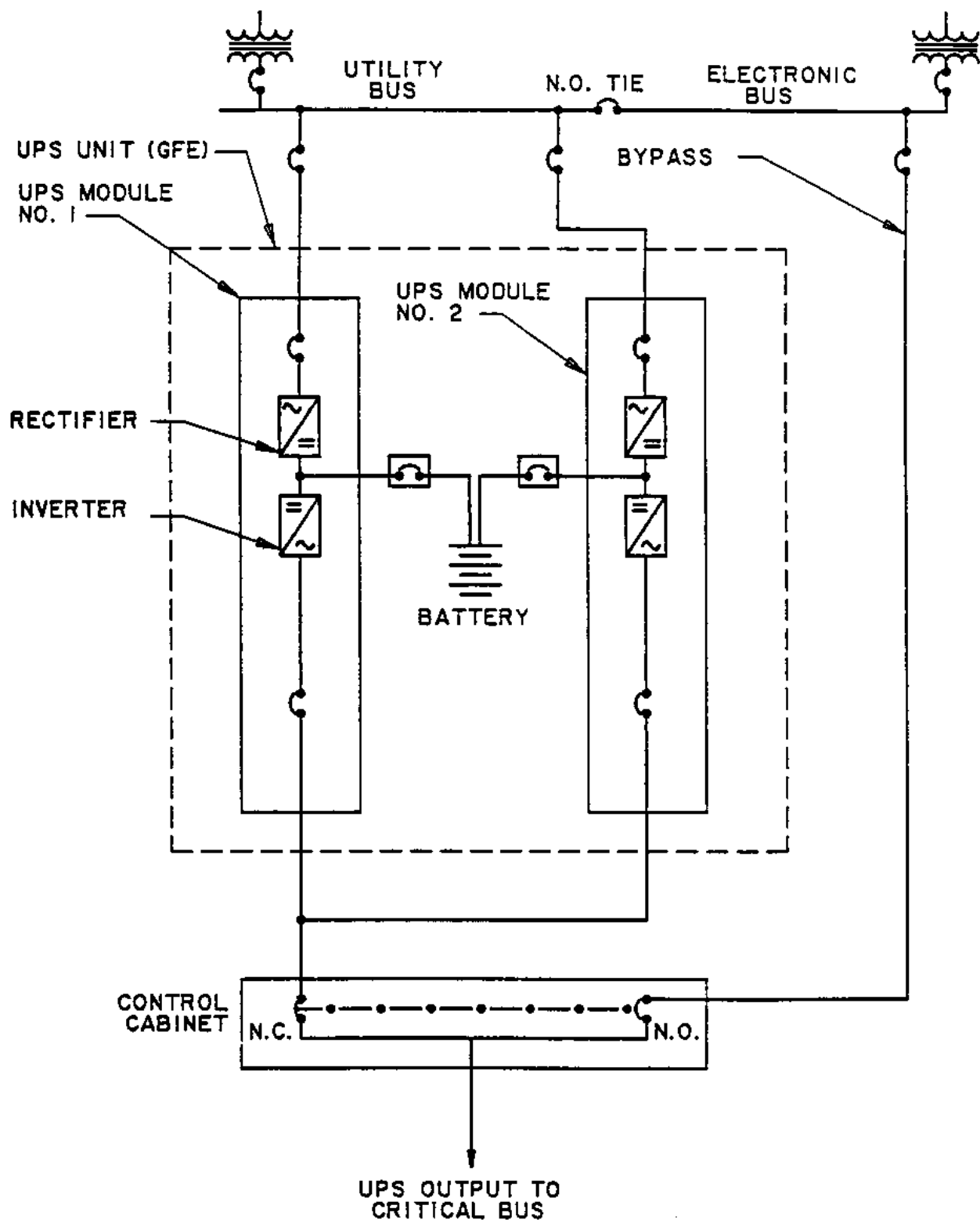

isolation of one UPS module (including its bypass) from the other module is inherent in the "cold" standby redundant configuration (see Figure 3).

c) The parallel redundant UPS contains a built-in manual bypass circuit in the control cabinet which will serve to isolate the UPS modules during emergency conditions or maintenance. This manual bypass circuit provides make-before-break switching and contains synchronizing provisions. Where frequency conversion is provided by the UPS, a solid state frequency conversion system or a motor-generator set will be required to bypass the UPS module.

4.7 UPS Distribution System. The UPS system serves critical loads only. Noncritical loads are served by separate distribution systems supplied from either the electronic or utility bus as appropriate.

4.7.1 Critical Load Protection. Provide critical load panels with current-limiting circuit breakers or fast acting fuses to shorten the transient effects of undervoltages caused by load faults.

4.7.2 Critical Motor Loads. Due to the energy losses and the starting current problem inherent in motor-generator sets, their connection to a UPS bus should be limited to frequency-conversion applications only. Generally, motor-generator sets shall be started on the UPS bypass circuit. However, motor-generator sets may be started on the rectifier mode of operation under the following conditions:

a) When rating of the motor-generator set is less than 5 percent of the UPS rating.

b) When reduced voltage starters are utilized for each motor load.

c) When more than one motor-generator set is connected to the critical bus, each set must be energized sequentially rather than simultaneously.

Solid state frequency conversion systems may be considered in lieu of motor-generator sets.

4.8 Emergency Electric Power Source Requirements. The UPS system can serve the critical electronic load continuously during periods of normal source electric power outage only if one or more emergency engine generators are provided and sized to supply not only UPS equipment, but all necessary auxiliary equipment such as lighting, ventilation, and air conditioning. The emergency electric power source shall meet the criteria given in paras. 4.8.1 through 4.8.5.

4.8.1 Automatic Operation. The emergency generator(s) shall be automatic start, automatic transfer-to-load upon normal electric power failure and shall include provisions for automatic load shedding and load restoration where required.

4.8.2 Paralleling. At a minimum, manual synchronizing of the emergency generator(s) with the normal electric power source shall be provided. As an alternative, automatic synchronizing of the emergency generator with the

normal electric power source may be considered. If more than one generator is installed, automatic paralleling capability should be provided. Parallel operation of generators with the local commercial utility supply may require the approval of the local utility company.

4.8.3 Starting and Maintenance Considerations. Controls shall allow delay in starting the emergency generator(s) from 10 to 120 seconds (variable to be set by the facility) to avoid cycling of the generator(s) during momentary transients or outages of the normal electric power supply. Controls should also provide a test position on generators to allow them to be run for a set period until the temperature stabilizes (usually less than 30 minutes) for maintenance purposes. This procedure should be done once every 2 weeks.

4.8.4 Service Configuration for Small Loads. For a small installation, it may be economically and operationally feasible to have the same emergency electric generator supply both the UPS equipment and any other essential auxiliary system loads.

4.8.5 Battery Charging Restrictions. Do not provide for additional battery charging requirements when sizing the emergency generator. The UPS is provided with an automatic control which limits the battery charging current to 3 percent of the output rating whenever the emergency generator is furnishing power to the UPS unit and the UPS unit is providing rated load.

4.9 Electromagnetic Interference (EMI) Suppression. Determine the necessity for the UPS installation to conform with the EMI suppression requirements of MIL-STD-461, Electromagnetic Interference Characteristics, Requirements for Equipment. UPS equipment is not furnished with EMI suppression provisions unless the facility is located on an EMI sensitive site. Where EMI suppression is necessary for a specific installation, all conductors shall be installed in threaded rigid steel conduit to meet EMI suppression requirements.

4.10 UPS Battery. The GFE battery provided is a heavy duty industrial unit of the lead calcium type having an ampere-hour rating sufficient to supply the direct current to the inverter as covered by the manufacturer's installation instructions. Battery racks are also GFE. The battery is normally furnished with two-tier racks. Battery racks shall be grounded. Seismic racks shall be provided where required.

4.11 Remote Alarms. The UPS equipment is supplied with a GFE remote monitor panel to be installed in the operating space served by the UPS unit or in another continuously occupied room, such as a guard office. Since UPS equipment rooms are usually unattended, additional remote indicating devices shall be provided to monitor the environmental control and fire alarm system of UPS module and battery rooms.

4.12 UPS and Battery Room Requirements. The UPS modules and associated battery shall be installed in separate rooms. Construction should be of permanent type. The wall separating the UPS module room from the battery room should be fireproof (1-hour rating). It is recommended that, where practical, space be provided in the UPS module and battery rooms for the addition of future UPS equipment. Additional design requirements are given in paras. 4.12.1 through 4.12.4.

4.12.1 Installation Considerations. Incorporate the UPS module and battery manufacturer's installation instructions for weights, dimensions, efficiency, and required clearances in the design. Special attention should be given to floor loading for the battery room, entrance door dimensions for installation of UPS modules, and ceiling height for clearance of necessary environmental systems.

4.12.2 NEC, OSHA, and ANSI Requirements. Design the battery room in accordance with Article 480 of the "National Electrical Code", OSHA, and ANSI requirements. Provide emergency eyewash and shower facilities which, at minimum, comply with OSHA and ANSI Z35.1-81 Emergency Eyewash and Shower Equipment. Such facilities for emergency quick drenching of the eyes and body shall be provided within 25 ft (7.5 m) of the work area.

4.12.3 Emergency Lighting Requirements. Provide emergency lighting units, which meet the requirements of Federal Specification W-L-305, Light Set, General Illumination in all UPS module and battery rooms.

4.12.4 Telephone Requirements. Provide a telephone in or adjacent to the UPS module room.

4.13 Environmental Control. Both the UPS module and battery room shall be provided with an environmental control system to maintain the prescribed inside room conditions. Each environmental control system shall consist of a primary system with backup capability to support the uninterruptible requirements of the electric power system. Upon failure of the primary system, automatic transfer to the backup system shall occur and shall sound an alarm indicating the need for maintenance. Design of these environmental control systems shall be in accordance with DM-3 and DM-12.1.

## Section 5: INSTALLATION OF DISTRIBUTION SYSTEM

### 5.1 Overhead Method

5.1.1 General. For details of overhead line design, refer to DM-4.2.

5.1.2 Limitations. The use of overhead lines shall be avoided in the following locations:

a) Electronics Facilities - For clearances of overhead electric power lines from electronics facilities, refer to DM-12.1.

b) Airfields - The installation of overhead lines in airfield clearance zones shall be avoided entirely. Regulations are imposed by the Federal Aviation Administration and Naval Air Systems Command.

c) Loading Areas - Piers and loading areas where overhead cranes operate shall be clear of aerial electric powerlines.

d) Industrial Areas - Congested industrial areas shall be clear of aerial lines. Requirements for ammunition storage areas are given in MIL-HDBK-1004/6, Lightning Protection. In addition, NAVSEA OP-5, Ammunition and Explosives Ashore, delineates restrictions concerning overhead line service for magazine facilities.

5.2 Underground Method. If average conditions prevail, underground construction and maintenance is more expensive than overhead installation. Applications shall be limited to cases in which other factors besides economics dictate. Examples of such factors have been indicated in para. 5.1.2.

5.2.1 Applications. Underground electric power distribution systems are normally more resistant to damage from severe atmospheric disturbances, traffic, and simple forms of sabotage than overhead systems.

5.2.2 Expansibility. Growth is a factor of extreme importance in the design of underground electric power systems. Spare capacity, as well as provisions for the future crossing of roadways, runways, and taxiways, shall be included in the design. Refer to MIL-HDBK-1004/2, Power Distribution Systems, for details of underground construction design and criteria for selection of draw-in or direct-burial systems.

## Section 6: LEVELS OF DISTRIBUTION VOLTAGE

6.1 Criteria Coverage. Distribution systems that have a medium voltage level of 2.4 to 35 kV are covered in this section except, that for 4.16 kV and below 400 Hz distribution systems, the criteria appears in DM-4.05. Systems in the utilization voltage level of 600 V and below are covered in MIL-HDBK-1004/4, Electrical Utilization Systems. Generally, the majority of systems supplying primary distribution voltages at naval activities are of the 15 kV class or less. However, voltages above 15 kV may be encountered as utility voltage supplying naval installations or as distribution voltages. In each case of distribution design, evaluate the cost of individual distribution components and energy losses, and adopt the most economical voltage level from an overall point of view.

6.2 System Voltages. Electrical power may be generated at the site or purchased.

6.2.1 Power Generated at Site. Criteria for electric power generated at the site is contained in DM-3.

6.2.2 Purchased Energy. Where purchased electrical power is used, adopt the most economical voltage, taking into consideration transformers, switchgear, control equipment, and energy losses.

6.2.2.1 2,400 V System. Use a 2,400 V system where total capacity does not exceed 5,000 kVA, but only when utility company service is at that voltage, and where a predominantly motor load includes motors rated at 200 hp or more. Where such motor conditions exist, use direct connection to motor starting equipment.

6.2.2.2 4,160 V System. Use a 4,160 V system for maximum demands not exceeding 7,500 kVA, but only when a utility company delivers electric power at that voltage level. Switchgear and cable at 4,160 V will give a more economical installation than one at 2,400 V. For loads including motors of 250 hp and over, and for groups of motors up to 7,000 kVA, the 4,160 V system may be more economical than any other voltage level.

6.2.2.3 6,900 V System. Use 6,900 V system only where the utility company delivers energy at this level or there are other special considerations.

6.2.2.4 12,000 V to 13,800 V Systems. These systems can be economically used for demands of 7,500 kVA and over.

6.2.2.5 15,000 V to 34,500 V Systems. These systems can be economically used for demands of 20,000 kVA and over, especially when the distances involved are considerable.



## Section 7: GROUNDING OF DISTRIBUTION SYSTEMS

7.1 General Requirements. Distribution systems using equipment with low impulse strength (for example, underground cables, dry-type transformers, and rotating equipment) shall be effectively grounded to avoid surge voltages. Each individual section of a circuit shall be grounded only once, at the source side. This action helps to control ground fault currents and to facilitate ground fault relaying. Detailed discussions of distribution system grounding are covered in ANSI/IEEE Standard 142-1982: IEEE Recommended Practice for Grounding Industrial and Commercial Power Systems, and ANSI/IEEE Standard 141-1986: IEEE Recommended Practice for Electrical Power Distribution for Industrial Plants.

7.2 Methods. The type and characteristics of a grounding device shall limit the maximum line-to-ground fault current to the value of the three-phase fault. Select a ground connection from the types given in paras. 7.2.1 through 7.2.3.

7.2.1 Solid Grounding. The solid grounding system shall be used for automatic clearing of ground faults. Use only on secondary systems or where impedance of transformers is included in the zero sequence current path. This connection shall be avoided for grounding of generators where the zero sequence or ground fault current at the generator terminals will exceed the three-phase fault current for which the generator is braced. For additional guidance on recommended practices and restrictions in applying this system grounding connection, refer to ANSI/IEEE Standard 141-1986.

7.2.2 Resistance Grounding. The resistance grounding system is applicable for:

- a) automatic clearance of ground faults,
- b) limiting ground fault currents to safe values, and
- c) reducing mechanical stresses caused by ground fault currents.

This type of connection may be used on wye-connected generators and transformers. For additional guidance on recommended practices and restrictions in applying this system grounding connection, refer to ANSI/IEEE Standard 141-1986.

7.2.3 Reactance Grounding. The reactance grounding system is applicable to:

- a) grounding generator systems and
- b) automatic clearing of ground faults.

When considering this type of grounding, remember that the available ground-fault current should have a value of at least 25 percent of the three-phase fault current in order to limit the transient overvoltages during the clearing of ground faults. For additional guidance on recommended practices and restrictions in applying this system grounding connection, refer to ANSI/IEEE Standard 141-1986.

## Section 8: SELECTION OF DISTRIBUTION SYSTEMS

8.1 Selection Factors. In selecting the distribution system, the designer must consider load requirements, permissible voltage regulation, reliability, flexibility, and life cycle cost.

8.2 Systems Available. The various systems recommended for use are for medium-voltage distribution systems, unless noted otherwise, and are described in paras. 8.2.1 through 8.2.11.

8.2.1 Conventional Simple-Radial Distribution System. The conventional simple-radial distribution system (see Figure 5) requires minimum transformer capacity, because it takes advantage of the total diversity among loads and requires less space. The main disadvantages are low flexibility, poor voltage regulation, and not much reliability because a simple fault in the main bus may shut off service completely. Cable cost and energy losses are high. The system should ordinarily be limited to 1,000 kVA of maximum demand and to a low-voltage distribution system.

8.2.2 Modern Simple-Radial Distribution System. The modern simple-radial distribution system (see Figure 6) can be used for capacities in excess of 1,000 kVA. The length of low-voltage feeders is kept to a minimum, reducing cable cost and energy losses. Size each transformer to handle the peak load of the area served. The main inconvenience of this system is that a fault in the primary circuit can shut off service to all transformers.

8.2.3 Modified Modern Simple-Radial Distribution System. The modified modern simple-radial distribution system (see Figure 7) provides all the advantages of the modern simple-radial type, but includes important improvements in reliability. The initial cost, however, is higher.

8.2.4 Loop Primary-Radial Distribution Type. The loop primary-radial distribution system (see Figure 8) has the same characteristics as the modern simple-radial distribution type, but in addition provides a quicker restoration of service in the event of primary feeder or transformer failure. Advantages are lower installation costs and energy losses than those of any of the distribution systems previously discussed.

8.2.5 Banked Secondary-Radial Distribution System. The banked secondary-radial distribution system (see Figure 9) provides quick restoration of service for the whole system after primary cable fault or transformer failure. The secondary loop provides an emergency supply to affected areas, equalizes loads on all transformers, permits taking advantage of diversity among loads gaining transformers capacity, and allows large motors to start across the line. In general, the secondary loop provides greater flexibility, high efficiency, and good voltage regulation. Short circuit contribution from all transformers connected in parallel within the system should be taken into consideration.

8.2.6 Primary Selective-Radial Distribution System. The primary selective-radial distribution system (see Figure 10) differs from the modern simple-radial distribution type in that it uses two or more primary feeders

MIL-HDBK-1004/1

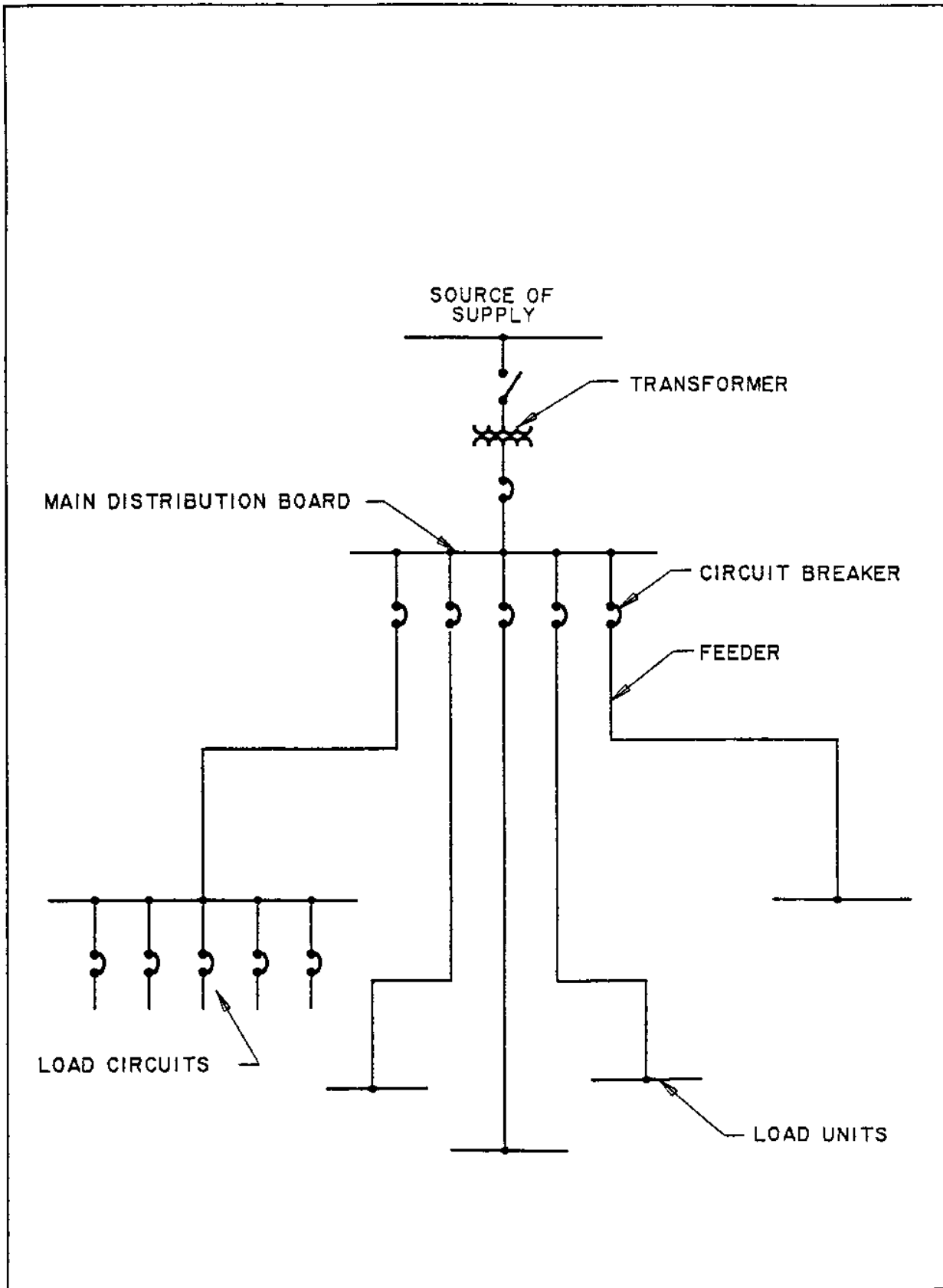

Figure 5  
Conventional Simple-Radial Distribution System

MIL-HDBK-1004/1

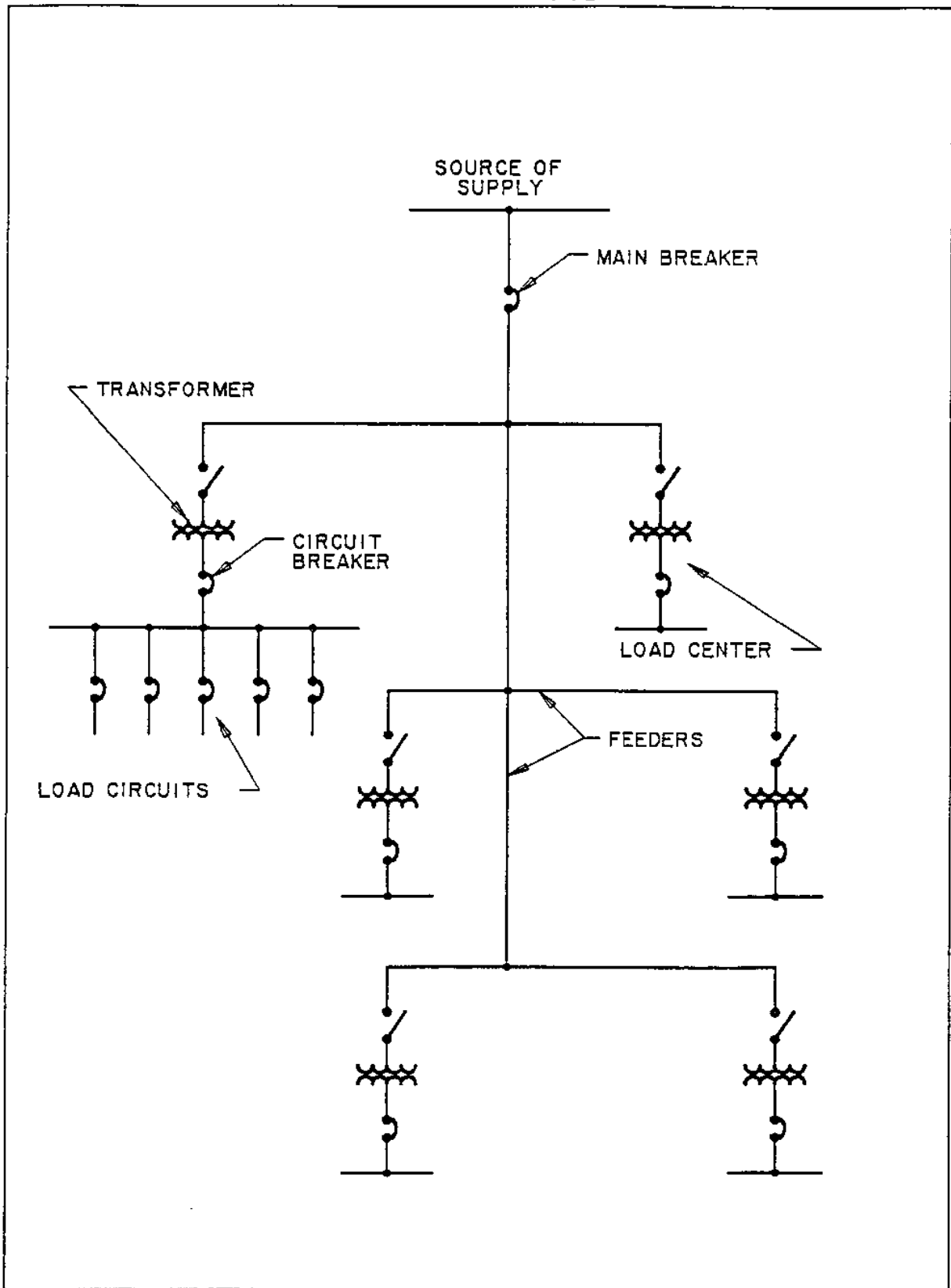

Figure 6  
Modern Simple-Radial Distribution System

MIL-HDBK-1004/1

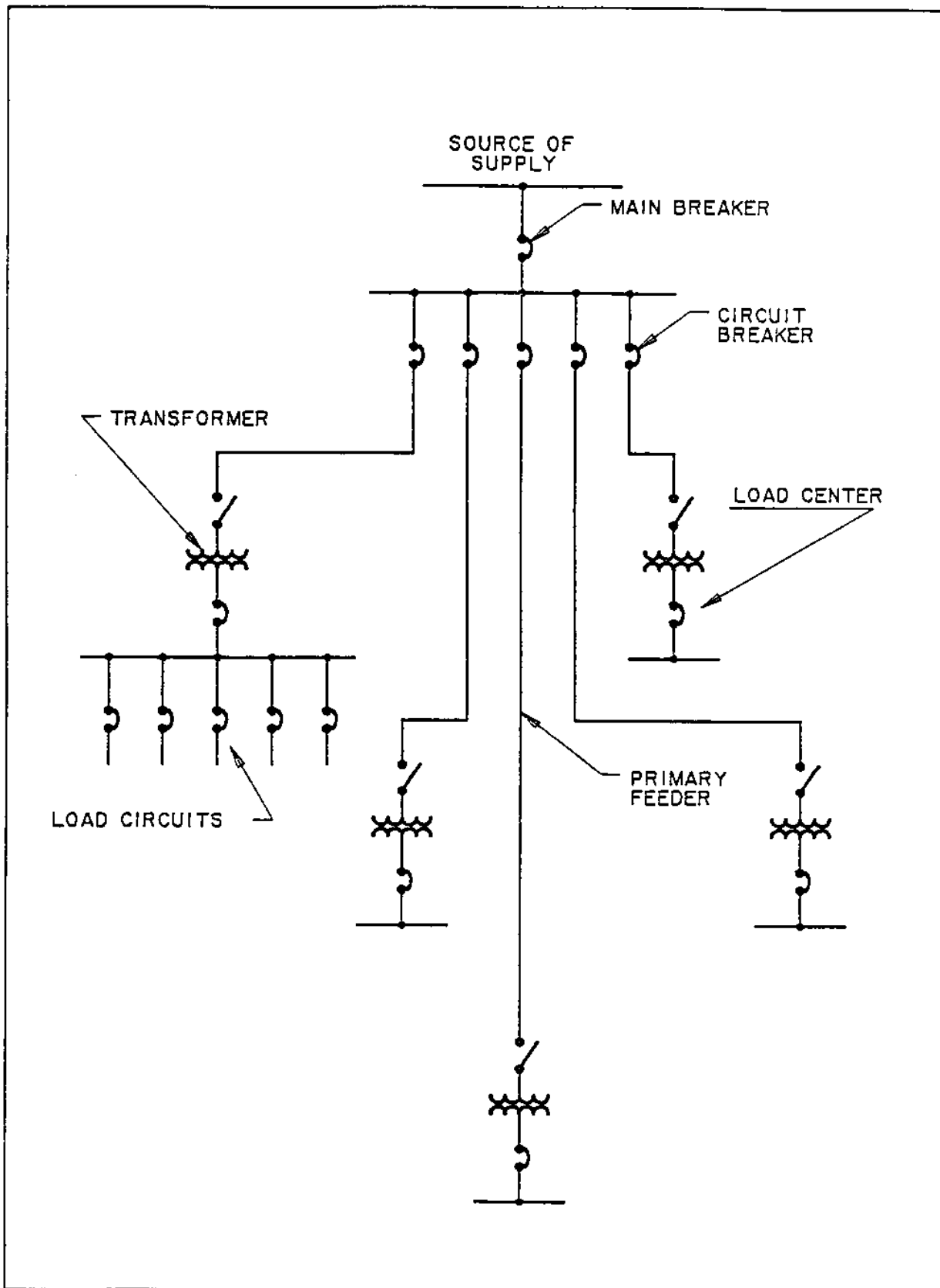

Figure 7  
Modified Modern Simple-Radial Distribution System

MIL-HDBK-1004/1

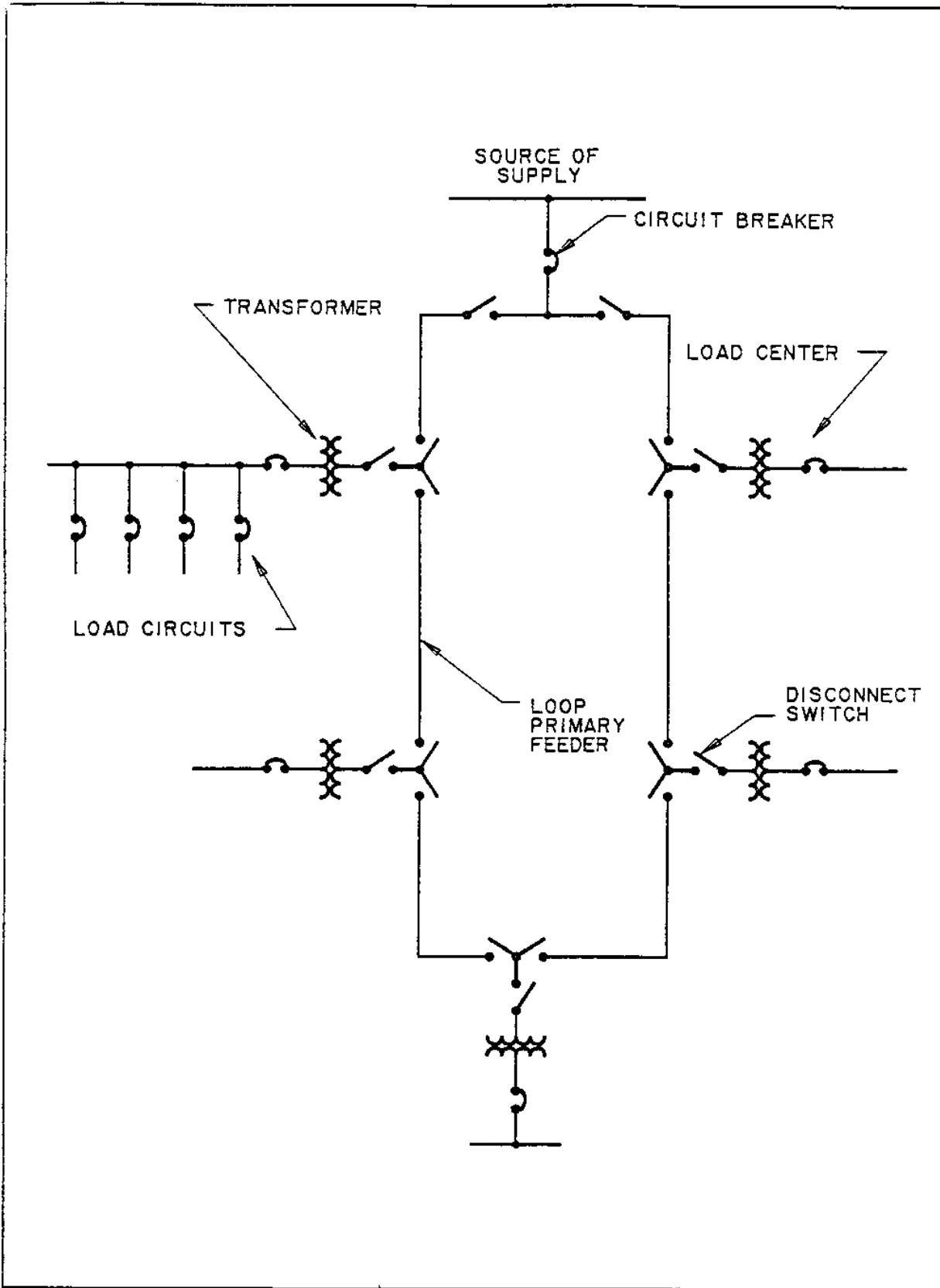

Figure 8  
Loop Primary-Radial Distribution System

MIL-HDBK-1004/1

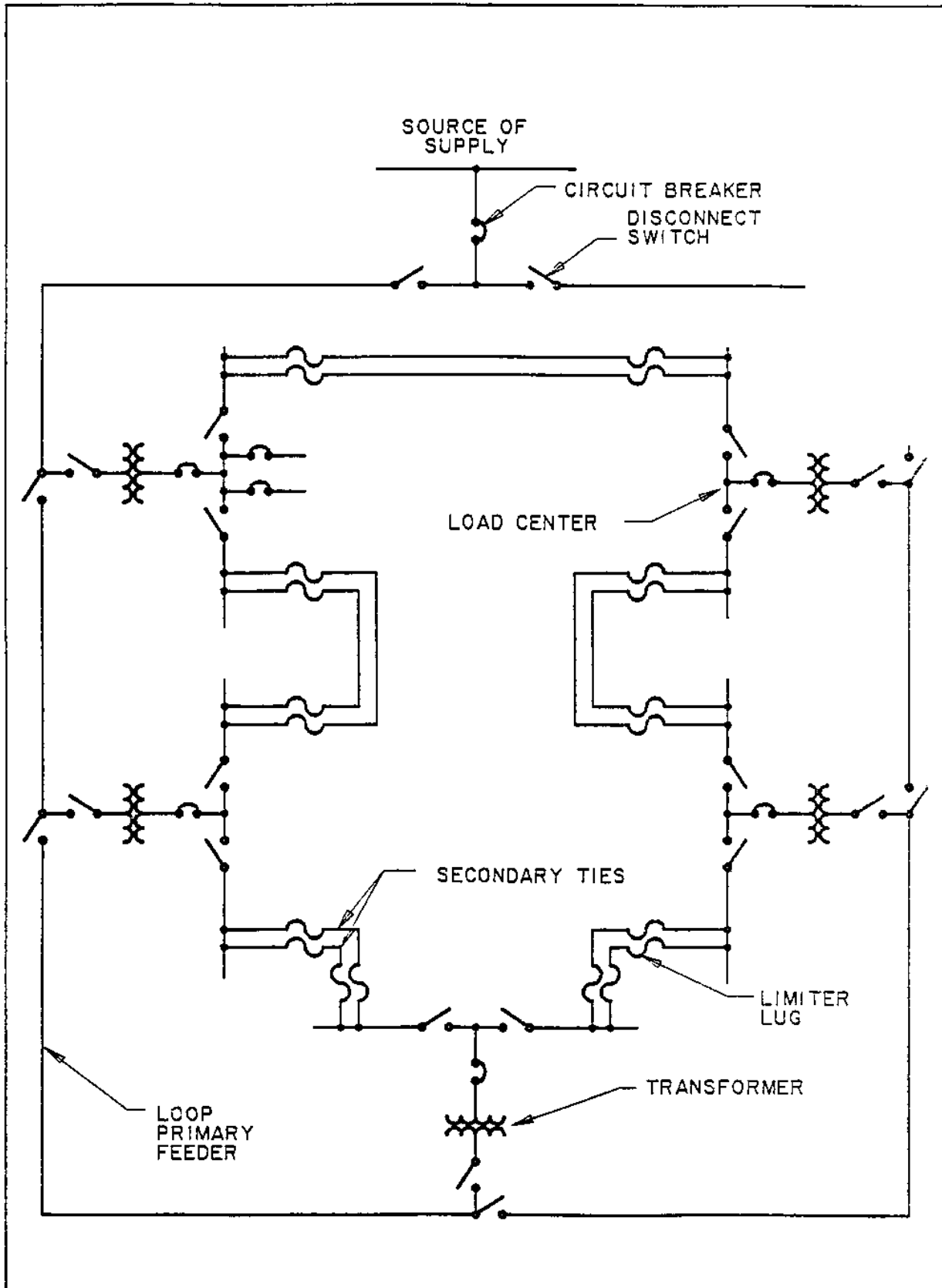

Figure 9  
Banked Secondary-Radial Distribution System

MIL-HDBK-1004/1

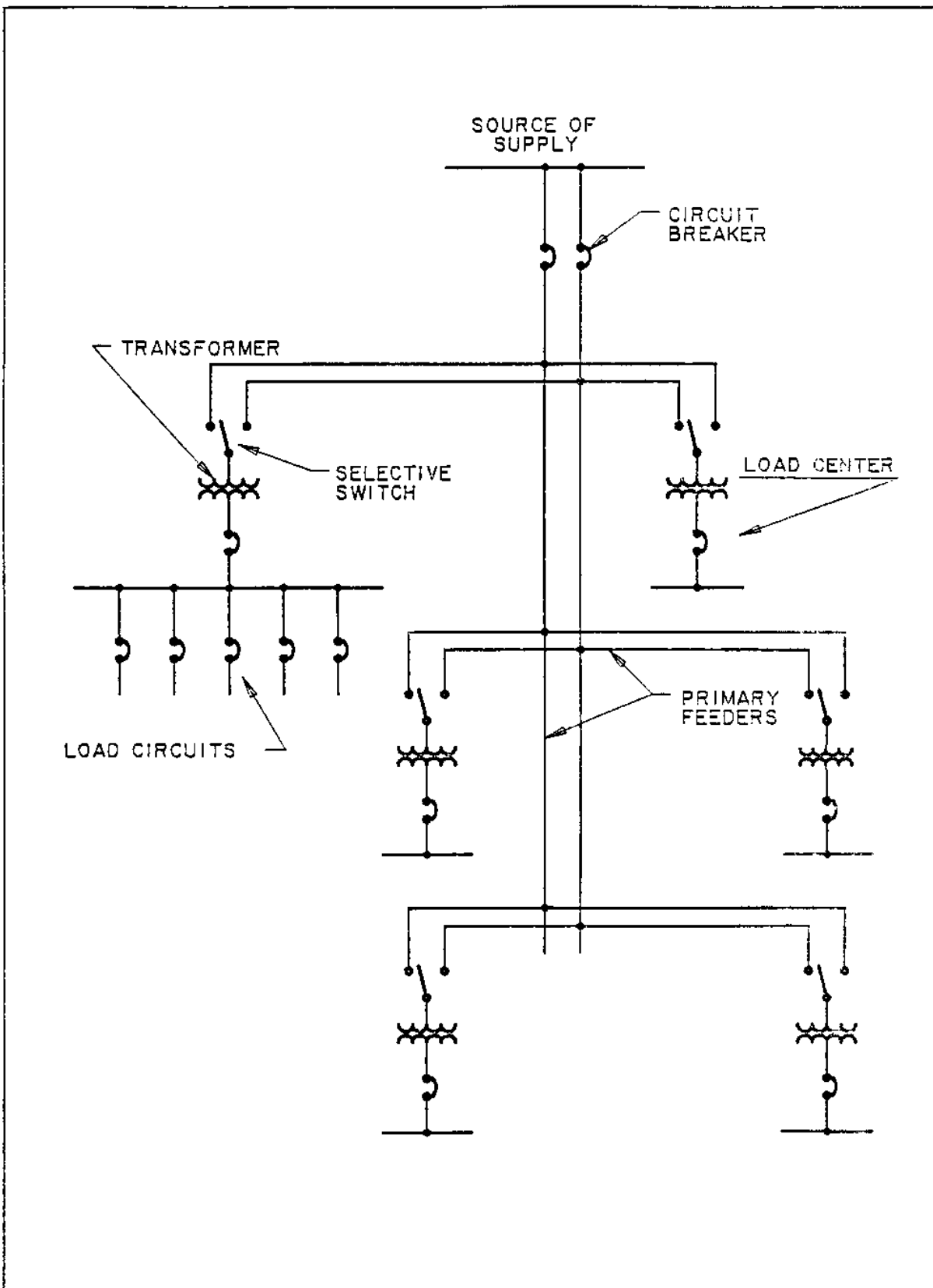

Figure 10  
Primary Selective-Radial Distribution System



instead of one, and provides each feeder with enough capacity to carry all the load. The extra investment (that is, providing for alternate primary feeders and selector switches) is compensated by the quick restoration of service in the event of primary feeder failure.

8.2.7 Secondary Selective-Radial Distribution System. The secondary selective-radial distribution system (see Figure 11) carries duplicate feeders up to the secondary bus of the load centers, thus compensating for any fault or malfunction in primary feeders or transformers. A common configuration involves pairs of unit substations connected through a normally open secondary tie circuit breaker. If the primary feeder or a transformer fails, the main secondary circuit breaker on the affected transformer is opened and the tie circuit breaker closed. Operation may be manual or automatic. Normally the stations operate as radial systems. With the loss of one primary circuit or transformer, the total substation load may be supplied by one feeder and one transformer. To allow for this condition, one (or a combination) of the following alternatives are applicable:

- a) Oversizing the primary feeders and both transformers so that one transformer can carry the total load.
- b) Oversizing the primary feeders and providing forced-air cooling to the transformer in service for the emergency period.
- c) Shedding nonessential load for emergency period.
- d) Oversizing the primary feeders and using the temporary overload capacity in the transformer and accepting the loss of transformer life.

DM 4.2 reads: ". . . Each transformer and its associated equipment shall be capable of carrying the essential loads of both sections. In sizing the transformers, take into consideration allowable overloading. . . ."

8.2.8 Simple Network Distribution System. A simple network distribution system (see Figure 12) must be used for high-density, heavy, concentrated loads. The main advantages of network distribution systems are continuity of service under any kind of fault in the system, automatic clearing of faults, flexibility and adaptability for shifting loads, and good voltage characteristics.

8.2.8.1 Network Protector. The network protector supplies forward power into the network, avoids any feedback into the primary line, and clears any fault automatically.

8.2.8.2 Limitation. The main objection to the use of network systems is the initial cost involved. Also, when secondary ties extend considerable distances, the probability of faults occurring is greater.

8.2.8.3 Secondary Loops. The purpose and advantages of the secondary loop are the same as those for the banked secondary-radial distribution type (para. 8.2.5). The number of individual cable sets connecting load centers will determine the reliability of the system. Install limiter lugs of the cable size used at both ends of any secondary ties. The size of ties shall be to supply all the load of any load center from one secondary tie.

MIL-HDBK-1004/1

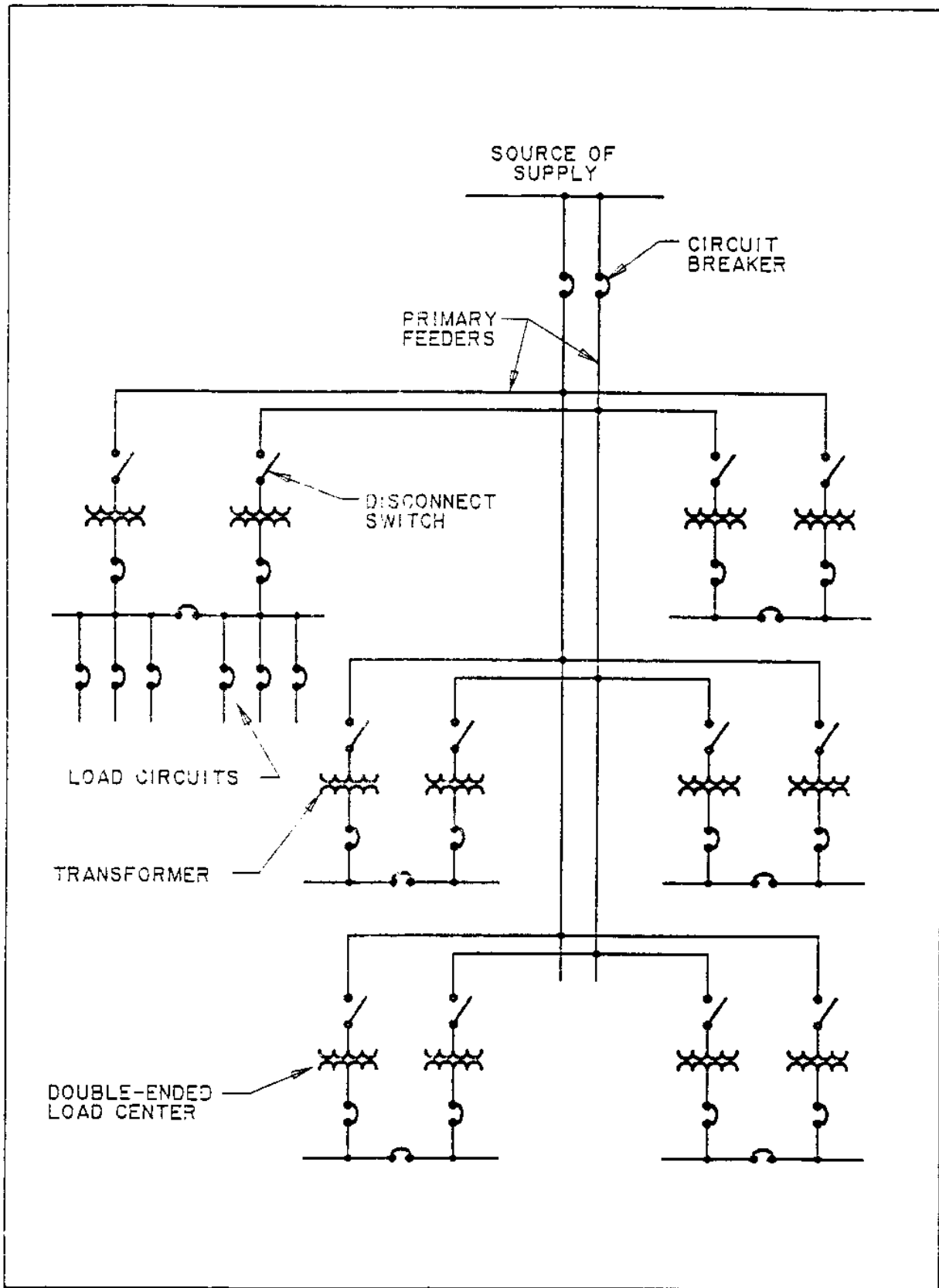

Figure 11  
Secondary Selective-Radial Distribution System

MIL-HDBK-1004/1

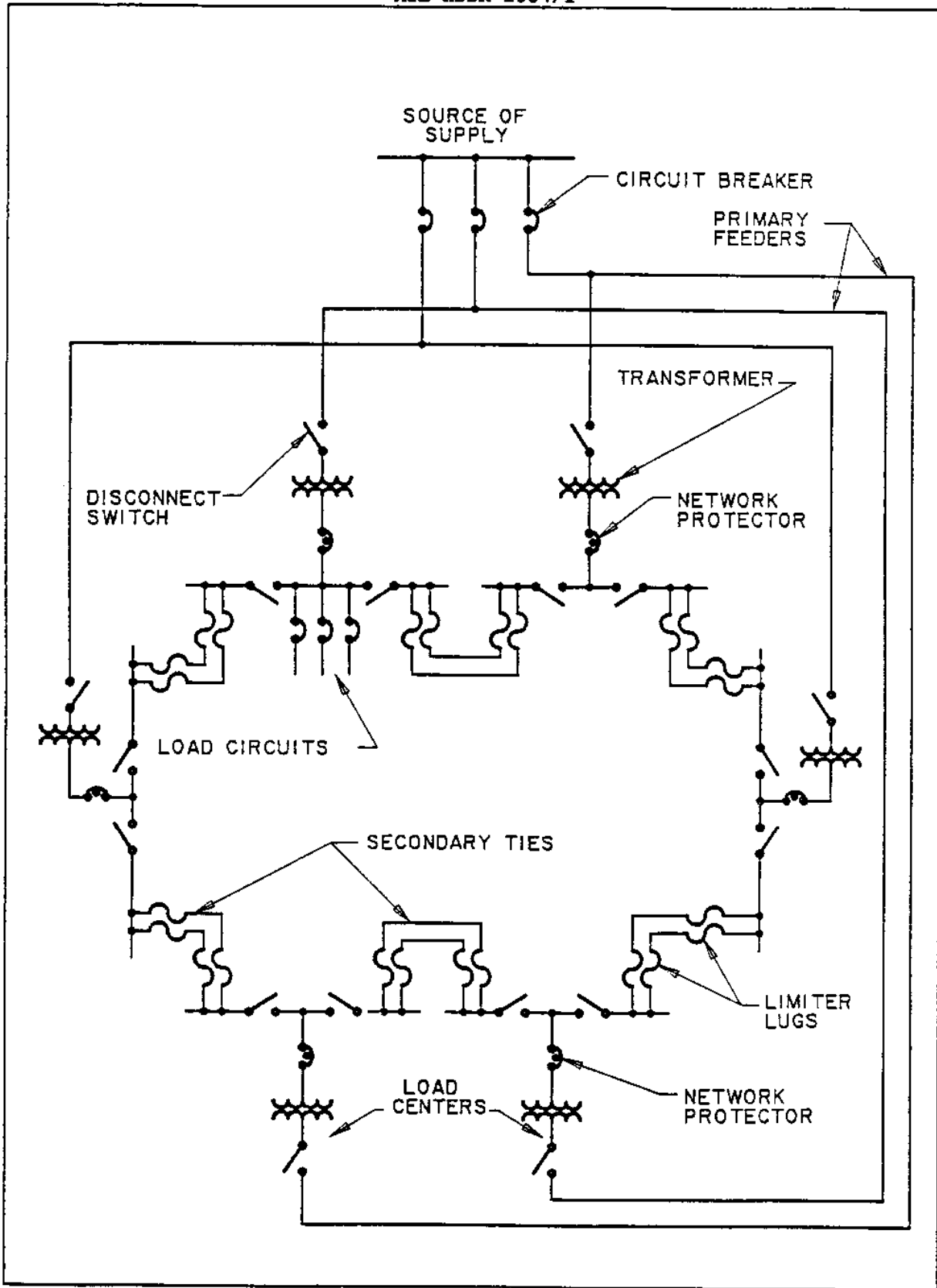

Figure 12  
Simple Network distribution System

8.2.9 Simple Spot-Network Distribution System. The simple spot-network distribution system (see Figure 13) should be used for installations that have heavy loads concentrated in small areas and considerable distances between such loads. This system has the inherent advantages of any network system. The system is limited, however, because it is not provided with secondary loops (refer to para. 8.2.8.3 for additional information).

8.2.10 Primary Selective Network Distribution System. The primary selective distribution system (see Figure 14) should be used for industrial applications in which heavy loads are evenly distributed. Each of the primary feeders shall be capable of carrying the entire load. The primary selective network distribution system provides continuity of service in the event of one primary feeder or transformer failure.

8.2.11 Primary Selective Spot-Network Distribution System. The primary selective spot-network distribution system (see Figure 15) provides the most reliable form of electric power distribution. In the event of a primary feeder failure, the transformers connected to the unfaulted primary feeder can carry all the load for the short period of time that it takes to transfer the other transformers to the unfaulted feeder. Each transformer need not have the total capacity of the load center.

MIL-HDBK-1004/1

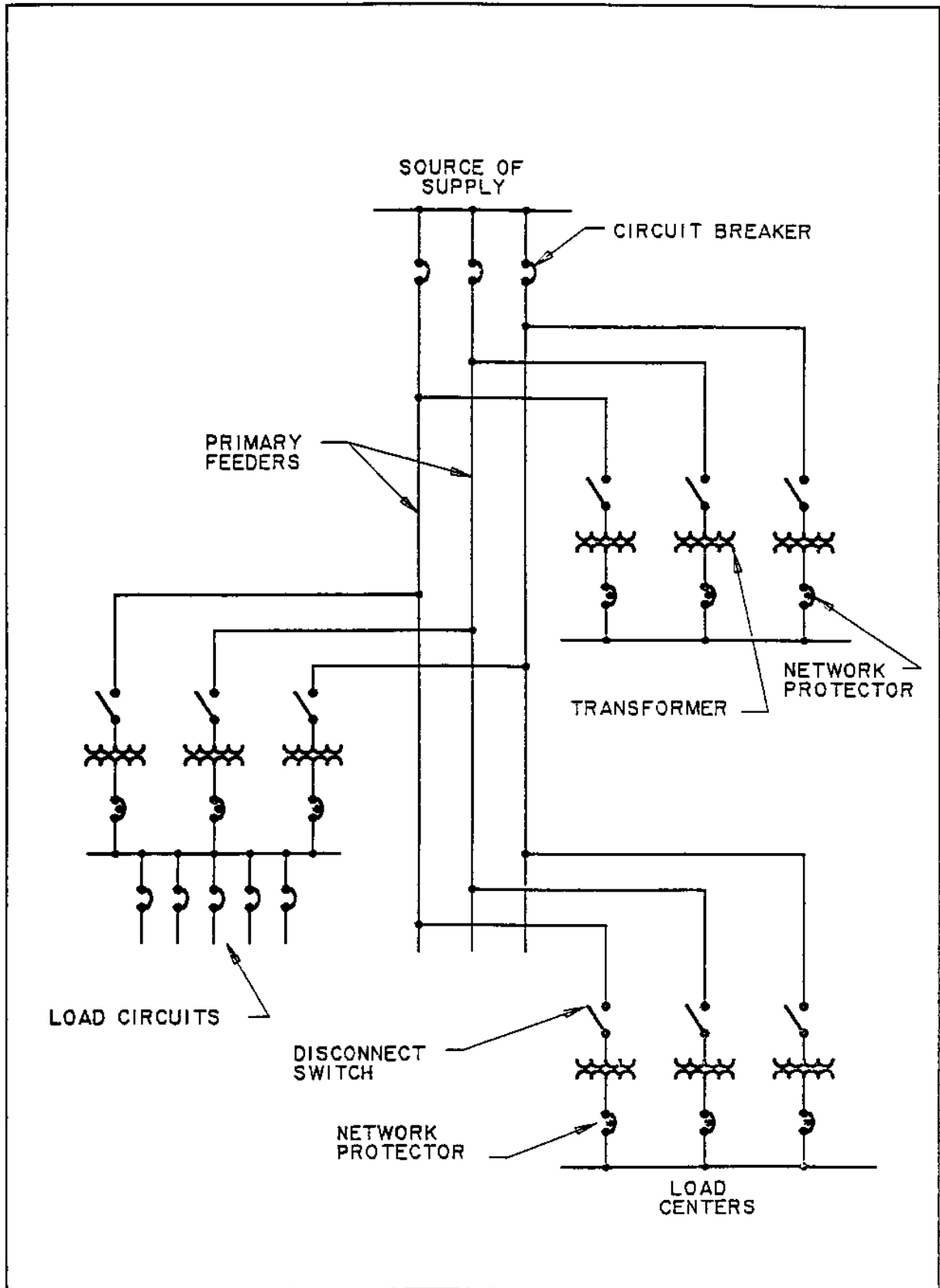

Figure 13  
Simple Spot-Network Distribution System

MIL-HDBK-1004/1

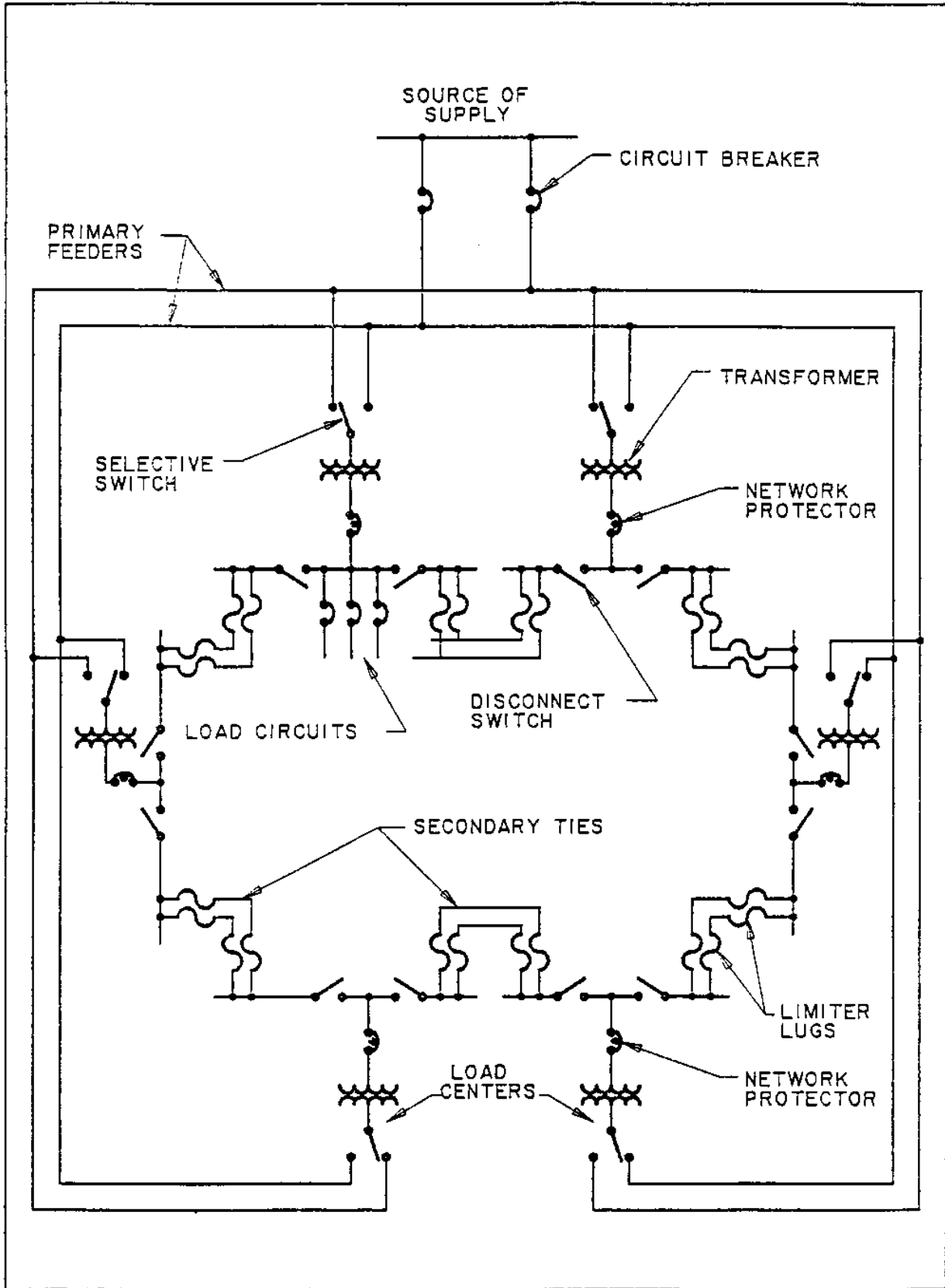

Figure 14  
 Primary Selective Network Distribution System

MIL-HDBK-1004/1

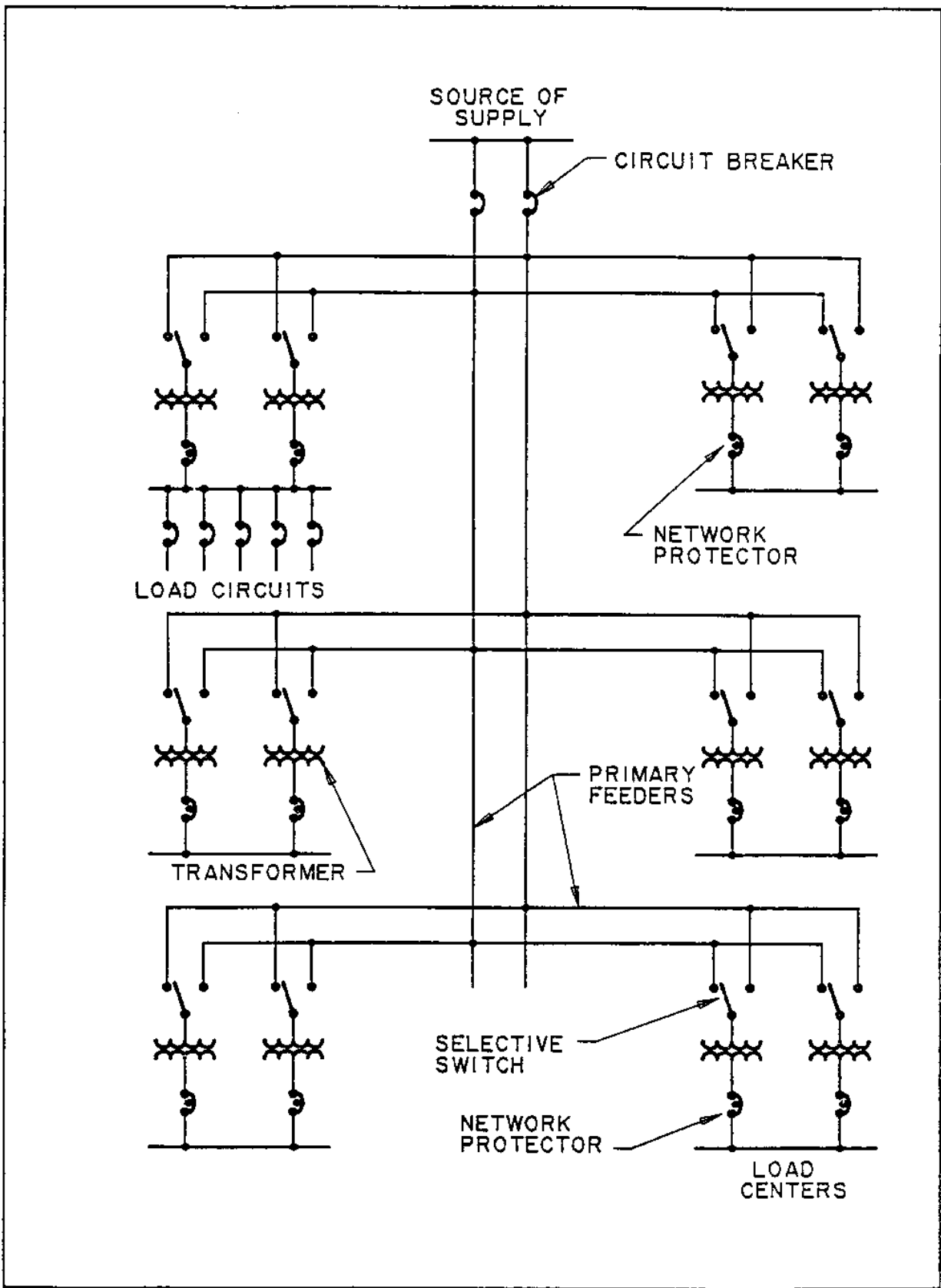

Figure 15  
Primary Selective Spot-Network Distribution System

BIBLIOGRAPHY

Documents of interest on Coincidence-Factor Relationships include:

Appendix B (Distribution of Diversity Benefits Under Maximum Noncoincident Demand Methods) of Electric Utility Cost Allocation Manual available from the National Association of Regulatory Utility Commissioners, Washington, DC 20044.

Chapter Four of Operational Economics of Electrical Utilities by Constantine Bary. Available from Columbia University Press, New York, NY 10025.

MIL-HDBK-419                      Grounding, Bonding, and Shielding for Electronic  
Equipment and Facilities



## REFERENCES

## Government Publications

Government agencies may obtain copies of military specifications, military standards, Federal Construction Guide Specifications, (FCGS) and Design Manuals (DM) from the United States Naval Publications and Forms Center, 5801 Tabor Avenue, Philadelphia, PA 19120, TWX: 710-670-1685, TELEX: 834295, AUTOVON telephone number 422-3321.

Non-Government organizations may obtain copies of military specifications, construction standards, and Federal Guide Specifications from the same source; Non-Government copies of Design Manuals must be obtained from the Superintendent of Documents, United States Government Printing Office, Washington, DC 20402.

MIL-STD-461	Electromagnetic Interference Characteristics, Requirements for Equipment
MIL-HDBK-411	Long Haul Communications (DCA) Power and Environmental Control for Physical Plant
MIL-HDBK-1004/2	Power Distribution Systems
MIL-HDBK-1004/4	Electrical Utilization System
MIL-HDBK-1004/6	Lightning Protection
MIL-HDBK-1190	Facility Planning and Design Guide
DM-3	Mechanical Engineering Series
DM-12.1	Electronic Facilities Engineering
FCGS W-L-305	Light Set, General Illumination
NAVSEA OP-5	Ammunition and Explosives Ashore
OSHA 1926.403-1986	Battery Rooms and Battery Charging

## Non-Government Publications

IEEE/ANSI Publications, Institute of Electrical And Electronics Engineers, Inc., 345 East 47th Street, New York, NY 10017.

ANSI	235.1-81	Emergency Eyewash and Shower Equipment
IEEE	45-116	Coincidence-Factor Relationship of Electric Service Load Characteristics

IEEE	141	Recommended Practice for Electric Power Distribution for Industrial Plants
IEEE	142	Recommended Practice for Grounding Industrial and Commercial Power Systems
	446-80	Recommended Practice for Emergency and Standby Power Systems
IEEE	C2-81	National Electrical Safety Code

IEEE Technical Paper 45-116, Transactions of AIEE (now IEEE), 1945, Volume 64, page 623 to 628, Coincidence-Factor Relationship of Electric Service Load Characteristics by Constantine Barry, is available as a reproduction copy only, from the Engineering Societies Library, New York, NY 10017.

National Fire Protection Association (NFPA), Batterymarch Park, Quincy, MA 02269.

NFPA No. 70	National Electric Code
NFPA No. 110	Emergency and Standby Power Systems

CUSTODIAN:  
NAVY-YD

PREPARING ACTIVITY  
NAVY-YD

PROJECT NO.  
FACR 0231