

UNIFIED FACILITIES CRITERIA (UFC)

EXTERIOR MECHANICAL UTILITY DISTRIBUTION



APPROVED FOR PUBLIC RELEASE; DISTRIBUTION UNLIMITED

UNIFIED FACILITIES CRITERIA (UFC)

EXTERIOR MECHANICAL UTILITY DISTRIBUTION

Any copyrighted material included in this UFC is identified at its point of use.
Use of the copyrighted material apart from this UFC must have the permission of the
copyright holder.

U.S. ARMY CORPS OF ENGINEERS

NAVAL FACILITIES ENGINEERING COMMAND (Preparing Activity)

AIR FORCE CIVIL ENGINEERING SUPPORT AGENCY

Record of Changes (changes indicated by \1\ ... /1/)

<u>Change No.</u>	<u>Date</u>	<u>Location</u>

UFC 3-430-09N
16 January 2004

FOREWORD

The Unified Facilities Criteria (UFC) system is prescribed by MIL-STD 3007 and provides planning, design, construction, sustainment, restoration, and modernization criteria, and applies to the Military Departments, the Defense Agencies, and the DoD Field Activities in accordance with [USD\(AT&L\) Memorandum](#) dated 29 May 2002. UFC will be used for all DoD projects and work for other customers where appropriate. All construction outside of the United States is also governed by Status of forces Agreements (SOFA), Host Nation Funded Construction Agreements (HNFA), and in some instances, Bilateral Infrastructure Agreements (BIA.) Therefore, the acquisition team must ensure compliance with the more stringent of the UFC, the SOFA, the HNFA, and the BIA, as applicable.

UFC are living documents and will be periodically reviewed, updated, and made available to users as part of the Services' responsibility for providing technical criteria for military construction. Headquarters, U.S. Army Corps of Engineers (HQUSACE), Naval Facilities Engineering Command (NAVFAC), and Air Force Civil Engineer Support Agency (AFCESA) are responsible for administration of the UFC system. Defense agencies should contact the preparing service for document interpretation and improvements. Technical content of UFC is the responsibility of the cognizant DoD working group. Recommended changes with supporting rationale should be sent to the respective service proponent office by the following electronic form: [Criteria Change Request \(CCR\)](#). The form is also accessible from the Internet sites listed below.

UFC are effective upon issuance and are distributed only in electronic media from the following source:

- Whole Building Design Guide web site <http://dod.wbdg.org/>.

Hard copies of UFC printed from electronic media should be checked against the current electronic version prior to use to ensure that they are current.

AUTHORIZED BY:



DONALD L. BASHAM, P.E.
 Chief, Engineering and Construction
 U.S. Army Corps of Engineers



DR. JAMES W. WRIGHT, P.E.
 Chief Engineer
 Naval Facilities Engineering Command

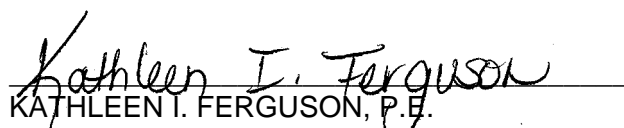

KATHLEEN I. FERGUSON, P.E.
 The Deputy Civil Engineer
 DCS/Installations & Logistics
 Department of the Air Force

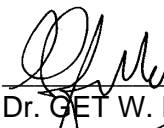

Dr. GET W. MOY, P.E.
 Director, Installations Requirements and
 Management
 Office of the Deputy Under Secretary of Defense
 (Installations and Environment)

CONTENTS

	Page
CHAPTER 1 INTRODUCTION	
Paragraph 1-1 PURPOSE AND SCOPE	1-1
1-2 APPLICABILITY	1-1
1-2.1 General Building Requirements	1-1
1-2.2 Safety	1-1
1-2.3 Fire Protection	1-1
1-2.4 Antiterrorism/Force Protection	1-1
APPENDIX A MIL-HDBK 1003/8A.....	A-1

CHAPTER 1

INTRODUCTION

1-1 **PURPOSE AND SCOPE.** This UFC is comprised of two sections. Chapter 1 introduces this UFC and provides a listing of references to other Tri-Service documents closely related to the subject. Appendix A contains the full text copy of the previously released Military Handbook (MIL-HDBK) on this subject. This UFC serves as criteria until such time as the full text UFC is developed from the MIL-HDBK and other sources.

This UFC provides general criteria for the design of steam, high-pressure water, chilled water, natural gas, and compressed air.

Note that this document does not constitute a detailed technical design, maintenance or operations manual, and is issued as a general guide to the considerations associated with design of economical, efficient and environmentally acceptable heating plants.

1-2 **APPLICABILITY.** This UFC applies to all Navy service elements and Navy contractors; all other DoD agencies may use this document unless explicitly directed otherwise.

1-2.1 **GENERAL BUILDING REQUIREMENTS.** All DoD facilities must comply with UFC 1-200-01, *Design: General Building Requirements*. If any conflict occurs between this UFC and UFC 1-200-01, the requirements of UFC 1-200-01 take precedence.

1-2.2 **SAFETY.** All DoD facilities must comply with DODINST 6055.1 and applicable Occupational Safety and Health Administration (OSHA) safety and health standards.

NOTE: All **NAVY** projects, must comply with OPNAVINST 5100.23 (series), *Navy Occupational Safety and Health Program Manual*. The most recent publication in this series can be accessed at the NAVFAC Safety web site: www.navfac.navy.mil/safety/pub.htm. If any conflict occurs between this UFC and OPNAVINST 5100.23, the requirements of OPNAVINST 5100.23 take precedence.

1-2.3 **FIRE PROTECTION.** All DoD facilities must comply with UFC 3-600-01, *Design: Fire Protection Engineering for Facilities*. If any conflict occurs between this UFC and UFC 3-600-01, the requirements of UFC 3-600-01 take precedence.

1-2.4 **ANTITERRORISM/FORCE PROTECTION.** All DoD facilities must comply with UFC 4-010-01, *Design: DoD Minimum Antiterrorism Standards for Buildings*. If any conflict occurs between this UFC and UFC 4-010-01, the requirements of UFC 4-010-01 take precedence.

UFC 3-430-09N
16 January 2004

APPENDIX A

**MIL-HDBK 1003/8A
EXTERIOR DISTRIBUTION OF STEAM, HIGH PRESSURE WATER, CHILLED
WATER, NATURAL GAS, AND COMPRESSED AIR**

INCH-POUND

MIL-HDBK-1003/8A
15 AUGUST 1990
SUPERSEDING
MIL-HDBK-1003/8
30 SEPTEMBER 1987

MILITARY HANDBOOK

EXTERIOR DISTRIBUTION OF STEAM,
HIGH TEMPERATURE WATER, CHILLED WATER,
NATURAL GAS, AND COMPRESSED AIR

NO DELIVERABLE DATA REQUIRED BY THIS DOCUMENT

AREA FACR

DISTRIBUTION STATEMENT A. APPROVED FOR PUBLIC RELEASE: DISTRIBUTION IS
UNLIMITED

MIL-HDBK-1003/8A

ABSTRACT

Presented here is basic yet comprehensive design guidance and technical data for exterior distribution piping systems. Services supported by these systems include: steam supply, high-temperature water, chilled water, cooling or condensing water, natural gas, and compressed air to various buildings and other facilities. This handbook also contains data covering return systems for condensate, water, and other spent services. Additional design data includes information on loads and fluid conditions, fluid characteristics, and distribution site locations. Factors governing tests for field permeability, soil resistivity, soil stability, and water conditions, information on distribution pipe sizing, valves and supports, distribution methods, and piping specifications and codes are provided. Material included also covers ownership, operations, and maintenance cost variables associated with permanent or temporary sites.

MIL-HDBK-1003/8A
Change 2, 30 December 1991

FOREWORD

This military handbook has been developed from an extensive evaluation of shore establishment facilities, surveys of new materials' availability and construction methods, selections from the best design practices of the Naval Facilities Engineering Command (NAVFACENGCOCM), other government agencies and the private sector. MIL-HDBK-1003/8A uses and references design data standards established and validated by national professional societies, associations, and technical institutes. Deviations from these criteria, in planning, engineering, design and construction of naval shore facilities, cannot be made without prior approval of NAVFACENGCOCM HQ Code 04.

Design methods and practices cannot remain static any more than the functions they serve or the technologies used. Accordingly, recommendations for improvement are encouraged and should be furnished on the DD Form 1426 provided inside the back cover to Commander, Western Division, Naval Facilities Engineering Command, Code 406, Building 203, San Bruno, CA 94066, telephone (415) 244-3331.

THIS HANDBOOK SHALL NOT BE USED AS A REFERENCE DOCUMENT FOR PROCUREMENT OF FACILITIES CONSTRUCTION. IT IS TO BE USED IN THE PURCHASE OF FACILITIES ENGINEERING STUDIES AND DESIGN (FINAL PLANS, SPECIFICATIONS, AND COST ESTIMATES). DO NOT REFERENCE IT IN MILITARY OR FEDERAL SPECIFICATIONS OR OTHER PROCUREMENT DOCUMENTS.

NOTICE OF CHANGE

MIL-HDBK-1003/8A
 NOTICE 1
 30 AUGUST 1991

MILITARY HANDBOOK

EXTERIOR DISTRIBUTION OF STEAM, HIGH TEMPERATURE WATER
 CHILLED WATER, NATURAL GAS, AND COMPRESSED AIR

TO ALL HOLDERS OF MIL-HDBK-1003/8A:

1. THE FOLLOWING PAGES OF MIL-HDBK-1003/8A HAVE BEEN REVISED AND SUPERSEDE THE PAGES LISTED:

NEW PAGE	DATE	SUPERSEDED PAGE	DATE
63	30 August 1991	63	REPRINTED WITHOUT CHANGE
64	30 August 1991	64	30 August 1991

2. RETAIN THIS NOTICE AND INSERT BEFORE TABLE OF CONTENTS.

3. Holders of MIL-HDBK-1003/8A will verify that all changes indicated above have been made. This notice page will be retained as a check sheet. This issuance, together with appended pages, is a separate publication. Each notice is to be retained by stocking points until the military handbook is completely revised or canceled.

CUSTODIAN:
 NAVY-YD

PREPARING ACTIVITY:
 NAVY-YD

PROJECT NO.
 FACR-1061

AMSC N/A

DISTRIBUTION STATEMENT A. APPROVED FOR PUBLIC RELEASE: DISTRIBUTION UNLIMITED

MIL-HDBK-1003/8A
NOTICE 2
15 November 1991

MILITARY HANDBOOK

EXTERIOR DISTRIBUTION OF STEAM, HIGH TEMPERATURE HOT
WATER, CHILLED WATER, NATURAL GAS AND COMPRESSED AIR

TO ALL HOLDERS OF MIL-HDBK-1003/8A

1. THE FOLLOWING PAGES OF MIL-HDBK-1003/8A HAVE BEEN REVISED AND SUPERSEDE
THE PAGES LISTED:

NEW PAGE	DATE	SUPERSEDED PAGE	DATE
41	15 November 1991	41	15 August 1990
42	15 November 1991	42	15 August 1990

2. RETAIN THIS NOTICE AND INSERT BEFORE TABLE OF CONTENTS.

3. Holders of MIL-HDBK-1003/8A will verify that all changes indicated above
have been made. This notice page will be retained as a check sheet. This
issuance, together with appended pages, is a separate publication. Each
notice is to be retained by stocking points until the Military Handbook is
completely revised or cancelled.

CUSTODIANS:
NAVY-YD

PREPARING ACTIVITY:
NAVY-YD

PROJECT NO.
FACR-1063

DISTRIBUTION STATEMENT A. Approved for public release; distribution is
unlimited.

MIL-HDBK-1003/8A
Change 2, 30 December 1991

MECHANICAL ENGINEERING CRITERIA MANUALS

Criteria Manual	Title	Preparing Activity
DM-3.01	Plumbing Systems	WESTDIV
MIL-HDBK-1003/2	Incinerators	WESTDIV
DM-3.03	Heating, Ventilating, Air Conditioning, and Dehumidifying Systems	WESTDIV
DM-3.4	Refrigeration Systems for Cold Storage	WESTDIV
DM-3.5	Compressed Air and Vacuum Systems	WESTDIV
MIL-HDBK-1003/6	Central Heating Plants	NEESA
MIL-HDBK-1003/7	Steam Power Plants - Fossil Fueled	NEESA
MIL-HDBK-1003/8A	Exterior Distribution of Steam, High Temperature Water, Chilled Water, Natural Gas, and Compressed Air	WESTDIV
DM-3.09	Elevators, Escalators, Dumbwaiters, Access Lifts, and Pneumatic Tube Systems	WESTDIV
DM-3.10	Noise and Vibration Control for Mechanical Equipment (Tri-Service TM-5-805-4, AFM 88-37)	ARMY
MIL-HDBK-1003/11	Diesel Electric Generating Plants	WESTDIV
MIL-HDBK-1003/12	Boiler Controls	NEESA
MIL-HDBK-1003/13	Solar Heating of Buildings and Domestic Hot Water	NCEL
DM-3.14	Power Plant Acoustics (Tri-Service TM-5-805-9, AFM 88-20)	ARMY
MIL-HDBK-1003/17	Industrial Ventilation Systems	NEESA
MIL-HDBK-1003/19	Design Procedures for Passive Solar Buildings	NCEL

MIL-HDBK-1003/8A
 NOTICE 2
 30 December 1991

MILITARY HANDBOOK

EXTERIOR DISTRIBUTION OF STEAM, HIGH TEMPERATURE HOT
 WATER, CHILLED WATER, NATURAL GAS, AND COMPRESSED AIR

TO ALL HOLDERS OF MIL-HDBK-1003/8A

1. THE FOLLOWING PAGES OF MIL-HDBK-1003/8A HAVE BEEN REVISED AND SUPERSEDE THE PAGES LISTED:

NEW PAGE	DATE	SUPERSEDED PAGE	DATE
iii	30 December 1991	iii	15 August 1991
iv	30 December 1991	iv	15 August 1990
v	30 December 1991	v	15 August 1991
vi	30 December 1991	vi	15 August 1990
vii	30 December 1991	vii	15 August 1990
viii	30 December 1991	viii	15 August 1990
1	30 December 1991	1	Reprinted w/o Change
2	30 December 1991	2	15 August 1990
3	30 December 1991	3	15 August 1990
4	30 December 1991	4	Reprinted w/o Change
9	30 December 1991	9	15 August 1990
10	30 December 1991	10	15 August 1990
13	30 December 1991	13	15 August 1990
14	30 December 1991	14	Reprinted w/o Change
37	30 December 1991	37	15 August 1990
38	30 December 1991	38	15 August 1990
41	30 December 1991	41	15 August 1990
42	30 December 1991	42	15 August 1990
42a	30 December 1991		New Page
45	30 December 1991	45	15 August 1990
46	30 December 1991	46	Reprinted w/o Change
47	30 December 1991	47	15 August 1990
48	30 December 1991	48	15 August 1990
63	30 December 1991	63	Reprinted w/o Change
64	30 December 1991	64	30 August 1991
81	30 December 1991	81	Reprinted w/o Change
82	30 December 1991	82	15 August 1990
83	30 December 1991	82	15 August 1990
84	30 December 1991	82	15 August 1990
85	30 December 1991	82	15 August 1990

2. RETAIN THIS NOTICE AND INSERT BEFORE TABLE OF CONTENTS.

vii

3. Holders of MIL-HDBK-1003/8A will verify that all changes indicated above have been made. This notice page will be retained as a check sheet. This issuance, together with appended pages, is a separate publication. Each notice is to be retained by stocking points until the Military Handbook is completely revised or cancelled.

CUSTODIANS:
NAVY-YD

PREPARING ACTIVITY:
NAVY-YD

PROJECT NO.

FACR-1063

DISTRIBUTION STATEMENT A. Approved for public release; distribution is unlimited.

MIL-HDBK-1003/8A
Change 2, 30 December 1991

EXTERIOR DISTRIBUTION OF STEAM, HIGH TEMPERATURE WATER,
CHILLED WATER, NATURAL GAS, AND COMPRESSED AIR

CONTENTS

	Page
Section 1	INTRODUCTION
1.1	Scope 1
1.2	Cancellation. 1
1.3	Related Criteria. 1
Section 2	PLANNING FACTORS
2.1	Types of Exterior Distribution Systems. 2
2.1.1	Steam and Condensate. 2
2.1.2	Hot Water 2
2.1.3	Compressed Air. 2
2.1.4	Chilled Water 2
2.1.5	Cooling or Condensing Water 2
2.1.6	Natural Gas 2
2.2	Naval Facilities Guide Specifications (NFGS) Related to Distribution Systems. 3
2.2.1	NFGS-02685, Exterior Buried Natural Gas Distribution Systems. 3
2.2.2	NFGS-02693, Exterior Shallow Trench Heat Distribution System 3
2.2.3	NFGS-02694, Exterior Underground Heat Distribution Systems 3
2.2.4	NFGS-02695, Exterior Aboveground Steam Distribution System. 3
2.2.5	NFGS-02696, Exterior Piping Insulation. 4
2.2.6	NFGS-02697, Exterior Buried Pumped Condensate Return System 4
2.2.7	NFGS-02698, Exterior Buried Preinsulated Water Piping. 4
2.2.8	Exterior Compressed Air Piping System 4
2.3	Loads and Distribution System Locations 4
2.3.1	Requirements for Individual Facilities. 5
2.3.2	System Load Demand Factors. 5
2.3.3	Aboveground and Underground Systems 5
2.3.4	Distribution Routes 5
2.3.4.1	Aboveground Piping Routes 5
2.3.4.2	Buried Piping Routes. 8
2.3.5	Economic Studies. 8
2.3.5.1	Annual Owning, Operating, and Maintenance Costs 8
2.3.5.2	Steam Versus High Temperature Water Distribution. . . . 8
2.3.5.3	High-Pressure (above 50 psig) (344.5 kPa) Steam Versus Low-Pressure (0 to 14 psig) (0 to 103.4 kPa) Steam Distribution. 8
2.3.6	Insulation for Shallow Trench Systems Which Exceed 500 Feet. 8

MIL-HDBK-1003/8A
Change 2, 30 December 1991

	Page
2.3.6.1	Heat Loss Formulas. 8
2.3.6.2	Heat Loss and Cost Relationship 10
2.4	Federal Agency Approved System Suppliers. 10
2.4.1	Class A, B, C, and D Ground Water Conditions. 10
2.4.2	Class B, C, and D Ground Water Conditions 10
Section 3	GENERAL DESIGN FACTORS
3.1	Design Responsibilities for Underground Pre-engineered Heat Distribution Systems. 14
3.1.1	Design by Project Designer. 14
3.1.2	Design by System Supplier 14
3.2	Distribution Site Location. 15
3.2.1	Location Factors. 15
3.2.2	Subsurface Explorations 15
3.2.2.1	Timing of Survey. 15
3.2.2.2	Time of Year. 15
3.2.2.3	Exploration Considerations. 15
3.2.2.4	Test Explorations 15
3.2.2.5	Depth of Exploration. 19
3.2.2.6	Special Ground Considerations 19
3.2.2.7	Permeability Tests. 19
3.2.2.8	Test Results. 19
3.2.2.9	Soil Resistivity. 19
3.2.2.10	Soil Corrosiveness Classification 20
3.2.2.11	Soil Stability. 20
3.2.2.12	Soil Load-Bearing Capacity. 20
3.2.3	Site Classification 20
3.2.3.1	Class A, Severe 20
3.2.3.2	Class B, Bad. 20
3.2.3.3	Class C, Moderate 21
3.2.3.4	Class D, Mild 21
3.2.4	Analyzing Site Classification for Application of Pre-Engineered Underground System 21
3.2.5	Analyzing Site Classification for Application of Shallow Concrete Trench System. 21
3.2.5.1	Soils 21
3.2.5.2	Settlement of Trenches. 22
3.2.5.3	Under-Trench Drainage Systems 22
3.2.6	Reinforced Thermosetting Resin Plastic (RTRP) Pipe. . . 23
3.3	Service and Loads 23
3.3.1	Alternate Routes. 23
3.3.2	Pressure Drop 23
3.3.3	Obstacles 23
3.3.4	Future Loads. 23
3.3.5	Distribution Circuits 24
3.3.6	Route Types 24
3.3.6.1	Through Buildings 24

3.3.6.2	Exterior Steam Distribution	24
3.3.6.3	Aboveground Overhead Piping	24
3.3.6.4	Buried Piping	24
3.3.6.5	Condensate Return cost.	25
3.3.6.6	Choice of Route	25
3.3.6.7	Piping Layouts.	26
3.3.6.8	Underground	27
3.4	Insulation.	27
3.5	Miscellaneous	27
Section 4	SPECIFIC PIPING DESIGN FACTORS	
4.1	Fluid Characteristics	28
4.1.1	Steam	28
4.1.2	Condensate.	28
4.1.3	High Temperature Water (HTW), Medium Temperature Water (MTW), and Low Temperature Hot Water (LTW).	28
4.1.4	Compressed Air.	28
4.1.5	Natural Gas	28
4.2	Distribution System Piping.	28
4.2.1	Equivalent Lengths of Piping.	28
4.2.2	Sizing of Distribution Piping	28
4.2.2.1	Minimum Pipe Size	28
4.2.2.2	Steam Piping.	28
4.2.2.3	Condensate Returns	37
4.2.2.4	High Temperature Water (HTW) Piping	39
4.2.2.5	Chilled Water Piping.	39
4.2.2.6	Condenser Water Piping.	39
4.2.2.7	Natural Gas Piping.	39
4.2.2.8	Compressed Air.	39
4.2.3	Piping Specifications and Codes	39
4.2.3.1	Steam Supply and Condensate Return.	41
4.2.3.2	High Temperature Water, Medium Temperature Water, and Low Temperature Water	41
4.2.3.3	Natural Gas and Compressed Air.	41
4.2.3.4	Chilled and Condenser Water	41
4.2.4	Thermal Expansion of Steel and Copper Pipe.	42
4.2.4.1	Branch Lines.	42
4.2.4.2	Expansion Bends	42
4.2.4.3	Expansion Joints.	42
4.2.4.4	Flexibility Analysis.	42a
4.2.4.5	Stress Analysis	43
4.2.5	Insulation of Piping Systems.	43
4.2.5.1	Insulation Thickness.	43
4.2.5.2	Jackets	43
4.2.6	Drainage Provisions	43
4.2.6.1	Pitch	43
4.2.6.2	Drips and Vents	45

MIL-HDBK-1003/8A
Change 2, 30 December 1991

	Page
4.2.6.3	Condensate Systems. 45
4.2.7	Pipe Anchors. 46
4.2.7.1	Location. 48
4.2.7.2	Specification 48
4.2.7.3	Strength. 48
4.2.7.4	Guying. 48
4.2.7.5	Embedding 48
4.2.8	Supports. 48
4.2.8.1	Low Elevations. 48
4.2.8.2	High Elevations 48
4.2.8.3	Long Spans. 48
4.2.8.4	Underground Conduits. 48
4.2.9	Finish and Protection 50
4.3	Concrete Trench Design. 50
4.3.1	Depth of Trench 50
4.3.2	Drainage of Trench. 50
4.3.3	Tops. 50
4.3.4	Details 50
4.3.5	Valve Manholes. 51
4.3.6	Inspection Ports. 51
4.3.7	Crossings 51
4.3.8	Precast Concrete Shallow Trench Options 51
4.4	Manholes. 51
4.4.1	Drainage. 51
4.4.2	Waterproofing 51
4.4.3	Pipe Entry. 51

APPENDIX

APPENDIX A	65
----------------------	----

FIGURES

Figure 1	Relation Between Heat Loss and System Costs	11
2	Total Cost of Owning and Operating Three Hypothetical Systems.	11
3	Chart for Weight-Flow Rate and Velocity of Steam (30 psig) (206.7 kPa).	31
4	Chart for Weight-Flow Rate and Velocity of Steam (50 psig) (344.5 kPa).	31
5	Chart for Weight-Flow Rate and Velocity of Steam (100 psig) (689.4 kPa)	32

MIL-HDBK-1003/8A

	Page	
6	Chart for Weight-Flow Rate and Velocity of Steam (150 psig) (1033.5 kPa)	32
7	Values of C ₁ , Flow Factor in Equation 1	36
8	Low Volume Flow Rate Natural Gas Chart (10 to 10,000 CU FT/HR) (.283 to 283 m ³ /hr)	40
9	High Volume Flow Rate Natural Gas Chart (1,000 to 1 million CU FT/HR) (28.3 to 28,300 m ³ /hr)	40
10	Protective Arrangement for RTRP Pipe	47
11	Typical Aboveground Pipe Supports	49
12	Concrete Shallow Trench Heat Distribution System Detail 1	52
13	Concrete Shallow Trench Heat Distribution System Detail 2	53
14	Concrete Shallow Trench Heat Distribution System Detail 3	54
15	Concrete Shallow Trench Heat Distribution System Detail 4	55
16	Concrete Shallow Trench Heat Distribution System Detail 5	56
17	Concrete Shallow Trench Heat Distribution System Detail 6	57
18	Concrete Shallow Trench Heat Distribution System Detail 7	58
19	Concrete Shallow Trench Heat Distribution System Detail 8	59
20	Concrete Shallow Trench Heat Distribution System Detail 9	60
21	Concrete Shallow Trench Heat Distribution System Detail 10	61
22	Concrete Shallow Trench Heat Distribution System Detail 11	62
23	Concrete Shallow Trench Heat Distribution System Detail 12	63
24	Steel Carrier Piping Manhole Entry Detail (no scale)	64

TABLES

Table 1	Distribution Loads and Fluid Conditions	6
2	Advantages and Disadvantages of Steam and Hot Water Distribution Systems	9
3	Insulation Thickness (in inches) to be Assessed in Calculations	13
4	Location Factors for Each Distribution System	17

MIL-HDBK-1003/8A

		Page
5	Soil Classification	17
6	Site Classification Criteria	18
7	Representative Equivalent Length in Pipe/Diameter Ratio (L/D) for Various Valve and Fittings	30
8	Values of C ₂ , Flow Factor in Equation 1	18
9	Reasonable Velocities for Flow of Steam in Pipes	37
10	Return Pipe Capacities for 30 psig (206.7 kPa) Steam Systems Capacity Expressed in lbs/hr)	39
11	Return Pipe Capacities for 150 psig (1,033.5 kPa) Steam Systems (Capacity Expressed in lbs/hr)	39
12	Pipe Expansion in Inches Per 100 Feet (30.5 m) of Length for Temperature Shown	43
13	Condensate Loads from Aboveground Heat Distribution Piping (Pounds Per Hour Per 100 Linear Feet)	48
	REFERENCES	81

MIL-HDBK-1003/8A

PAGE xv INTENTIONALLY BLANK

MIL-HDBK-1003/8A
Change 2, 30 December 1991

Section 1: INTRODUCTION

1.1 Scope. Data and criteria in this military handbook apply to design of exterior distribution piping systems for supplying certain central generating plant services to various buildings and facilities and for returning such spent services to the plants.

1.2 Cancellation. This handbook, MIL-HDBK-1003/8A, cancels and supersedes MIL-HDBK-1003/8 of September 1987.

1.3 Related Criteria. All documents referenced in this handbook are listed in the reference section.

MIL-HDBK-1003/8A
Change 2, 30 December 1991

Section 2: PLANNING FACTORS

2.1 Types of Exterior Distribution Systems. Types of exterior distribution systems are as follows:

2.1.1 Steam and Condensate. These systems supply heat in the form of steam from central steam generating plants. Several buildings, building groups, or ship berthing facilities may be supplied with steam for domestic hot water and/or for space heating. Heating equipment using steam includes unit heaters, radiators, convectors, heating coils, and other devices. Process equipment using steam includes hot water heaters, laundry machinery, cleaning/plating tanks, kitchen equipment, and other devices. Condensate is returned to the central plant whenever possible.

2.1.2 Hot Water. System circulates hot water which supplies heat from a central heating plant to several buildings for space heating, domestic hot water, and process work, and returns the water to the central plant. High Temperature Water (HTW) systems operate at 260 degrees Fahrenheit (F) (127 degrees Celsius (C)) and higher; Medium Temperature Water (MTW) systems operate between 200 degrees F (93 degrees C) to 259 degrees F (126 degrees C); and Low Temperature Water (LTW) systems operate below 200 degrees F (93 degrees C). Material shall be selected to the same specifications as for High Temperature Water systems, except that Military Specification (Mil. Spec.) MIL-P-28584A, Pipe and Pipe Fittings, Glass Fiber Reinforced Plastic for Condensate Return Lines, plastic piping may be used for LTW distribution systems which have maximum of 125 psig at 250 degrees F (refer to para. 2.2.6).

2.1.3 Compressed Air. System supplies compressed air from a compressor plant to docks, air start systems, shops, hangars, and other structures.

2.1.4 Chilled Water. System circulates chilled water from a central refrigeration plant to several buildings for space cooling and returns the water to the central plant (refer to para. 2.2.7).

2.1.5 Cooling or Condensing Water. System distributes cooling water from a central source (such as a bay, stream, or cooling tower) to several facilities for condensing steam or refrigerants, for cooling water jackets, or stuffing boxes. The water is then returned to the source (cooling tower) or sent to waste in once-through systems.

2.1.6 Natural Gas. System distributes natural gas or propane for gas burning operations.

2.2 Naval Facilities Guide Specifications (NFGS) Related to Distribution Systems. The following NFGSs are for use in the design of the exterior distribution systems discussed in this handbook.

MIL-HDBK-1003/8A
Change 2, 30 December 1991

2.2.1 NFGS-02685, Exterior Buried Natural Gas Distribution Systems. NFGS-02685 covers these requirements for maximum system working pressures of 60 psig at 100 degrees F for exterior distribution systems for natural gas. Project drawings shall indicate the design for the entire piping system.

2.2.2 NFGS-02693, Exterior Shallow Trench Heat Distribution System. NFGS-02693 covers the requirements for exterior shallow trench heat distribution systems, including concrete trench, manholes, piping, pipe anchors, pipe supports, interface with each manhole and watershed to aboveground piping. The specification covers system components for working pressure of 150 psig (1034 kiloPascal (kPa)) steam at 366 degrees F (185 degrees C) and 125 psig (862 kPa) condensate at 250 degrees F (121 degrees C) or hot water at 450 degrees F (232 degrees C). Show the design for the entire piping systems and shallow concrete trench systems on the project drawings.

2.2.3 NFGS-02694, Exterior Underground Heat Distribution Systems. NFGS-02694 (formerly NFGS-15705) covers the requirements for Contractor designing and providing exterior buried factory-prefabricated preinsulated or pre-engineered preinsulated steam and condensate piping systems and hot water piping systems for Class A, B, C, and D ground water conditions including concrete pipe anchors exterior of manholes, interface with each manhole, and the watershed to aboveground piping. The specification covers system components for working pressure of 150 psig (1034 kPa) steam at 366 degrees F (185 degrees C) and 125 psig (862 kPa) condensate at 250 degrees F (121 degrees C) or hot water at 450 degrees F (232 degrees C). Show the design for the aboveground piping, the manholes, the piping within manholes, and the piping not in approved conduit systems on the drawings. The Contractor designs and provides buried factory-prefabricated preinsulated piping in a conduit or pre-engineered insulated piping system for which a Federal Agency Approved Brochure has been issued including concrete pipe anchors exterior of manholes, interface with each manhole and building, and the watershed to aboveground piping.

2.2.4 NFGS-02695, Exterior Aboveground Steam Distribution System. NFGS-02695 covers the requirements for exterior aboveground steam and condensate (hot water) piping systems: exposed to the weather exterior of buildings and supported on pedestals or poles; on piers, under piers, and in trenches on piers; and in tunnels, in manholes, and related work. The work also includes providing buried factory-prefabricated preinsulated steam and condensate piping under roads. The specification covers system components for working pressure of 150 psig (1034 kPa) steam at 366 degrees F (185 degrees C) and 125 psig (862 kPa) condensate at 250 degrees F (121 degrees C). Show the design for the aboveground piping, and the piping under roads on project drawings. The design includes manholes, the piping within manholes, (buried factory-prefabricated preinsulated piping in a conduit or pre-engineered insulated piping under roads for which a Federal Agency Approved Brochure has been issued), concrete pipe anchors, interface with each manhole, and the watershed to aboveground piping.

MIL-HDBK-1003/8A
Change 2, 30 December 1991

2.2.5 NFGS-02696, Exterior Piping Insulation. NFGS-02696 covers field-applied exterior piping insulation, insulation requirements for exterior steam piping, exterior condensate piping including aboveground piping, piping on piers, piping under piers, piping in trenches on piers, piping in tunnels, and piping in manholes.

2.2.6 NFGS-02697, Exterior Buried Pumped Condensate Return System. NFGS-02697 covers the requirements for exterior buried factory-prefabricated preinsulated pumped condensate (hot water) return piping systems suitable for installation in Class A, B, C, and D ground water conditions, including piping in manholes, plastic piping systems for which a Federal Agency Approved Brochure has been issued, and related work. Use the plastic carrier piping only for sizes 2, 3, 4, 5, 6, 8, and 10 inches. Thus, the connecting system piping should be of equal size or increased to the next size of the plastic carrier piping. NFGS-02697 also covers Contractor's responsibilities which include the following:

- a) design,
- b) provide exterior buried factory-prefabricated preinsulated pumped condensate (hot water), and
- c) provide plastic piping systems for Class A or Class B ground water conditions including concrete pipe anchors exterior of manholes, interface with each manhole, and the watershed to aboveground piping.

Show the design for the aboveground piping, the manholes, the piping within manholes, and the piping not in approved prefabricated conduit or pre-engineered systems on project drawings. The Contractor designs and provides direct buried factory-prefabricated preinsulated piping in a conduit or pre-engineered insulated piping system for which a Federal Agency Approved Brochure has been issued, including concrete piping anchors exterior of manholes, interface with each manhole, and the watershed to aboveground piping.

2.2.7 NFGS-02698, Exterior Buried Preinsulated Water Piping. NFGS-02698 covers the requirements for exterior buried factory-prefabricated preinsulated domestic water piping, including hot domestic water piping, recirculating hot domestic water piping, chilled water piping, chill-hot (dual-temperature) water piping, and hot water piping. Show the design for the entire piping systems on project drawings.

2.2.8 Exterior Compressed Air Piping System. Use NFGS-02682, Exterior Fuel Distribution System, for the requirements of furnishing and installing exterior compressed air piping.

2.3 Loads and Distribution System Locations. For approximate conditions, refer to Table 1.

MIL-HDBK-1003/8A

Table 1
Distribution Loads and Fluid Conditions

FLUID	USE	CAPACITY	FLUID PRESSURE, PSIG VACUUM, IN HG TEMPERATURE, DEGREES F	DEMAND FACTORS $\sqrt{}$	COMMENTS
Steam	Auxiliary power	Determined by heat balance	Boiler steam	1.0	Feedwater and fuel-oil heating
	Heating and snow melting	See criteria in DM-3.03	2 to 10 psig	1.0 $\sqrt{}$ for heating radiation,	
	Waterfront demands Process	See criteria in MIL-HDBK-1025/2 Laundry	150 psig maximum	0.8 $\sqrt{}$ for ventilation	High purity steam for nuclear ships
			100 psig	1.0 single berths	
	Kitchen	Bakery	10 to 40 psig	0.65 multiple berths	2-8 hr/day, 7 days/week, normally
			10 psig	1.0	8 hr/day, 5 days/week, normally
	Dry cleaning Hospital Laundry HW	Domestic HW: DM-3.01 Tons x steam rate/ton	70 psig	0.65	
			40 to 60 psig	0.65	
			5 to 45 psig	0.65	7 hr/day, 5 days/week, normally
	Refrigeration	Tons x steam rate/ton	5 to 45 psig	0.65	
Boiler steam pressure 26-28 in. Hg. vacuum			1.0	Turbine-driven centrifugal compressor	
Condensate return	Distribution loss Boiler feed	Tons x steam rate/ton	1.0	Absorption machine	
		Losses: Condensate blow-down or blow-off. Determined by amount and analysis of makeup Process depends on usage. Distribution 10 percent	20 to 60 psig	1.0 for continuous operation of condensate pumps	Check economics of returning condensate
				1.5 to 3 for intermittent operation of condensate pumps	

MIL-HDBK-1003/8A

Table 1 (continued)
Distribution Loads and Fluid Conditions

FLUID	USE	CAPACITY	FLUID PRESSURE, PSIG VACUUM, IN HG TEMPERATURE, DEGREES F	DEMAND FACTORS ^{1/}	COMMENTS
Hot Water (supply and return)	Heating and snow melting Process	Same criteria as for steam	10 to 100 psig	---	---
Chilled water supply and return	Refrigeration	gpm = $\frac{12,000 \text{ Btu/ton} \times \text{tons}}{500 \times (t_s - t_r)^{3/2}}$	Supply: 42 degrees F to 45 degrees F Return: 52 degrees F to 60 degrees F Pressure depends on friction and static heads	Same as for steam 1.0 ^{2/}	---
Condenser water	Refrigeration	3 gpm/ton	Supply 85 degrees F. Return 105 degrees F	1.0	---
Fuel Gas	Power system Process fuel gas burners	gpm = steam x 950 lbs/hr Btu/lb $500 \times (t_s - t_r)^{3/2}$	Pressure depends on friction and static heads	1.0	---
Compressed air	Low pressure medium pressure high pressure	---	---	---	---

^{1/} Demand factors are to be applied to total connected loads.

^{2/} Values shown are approximate. Actual Demand Factor is a site-specific determination and is based on actual load diversification.

^{3/} t_s = Water supply temperature; t_r = water return temperature.

MIL-HDBK-1003/8A

2.3.1 Requirements for Individual Facilities. The actual loads and conditions are determined from the design of each building and facility. Refer to P-272, Definitive Designs for Naval Shore Facilities, as guidance for preliminary estimates of requirements. The facility layout, design, and geographic factors will further define requirements.

2.3.2 System Load Demand Factors. For demand factors, refer to Table 1.

2.3.3 Aboveground and Underground Systems. When selecting a system, factors to consider are: permanent versus temporary use, high-water table, corrosiveness of soil for underground systems, cost and degree of hazard. Refer to para. 3.3.6.6.

2.3.4 Distribution Routes. Select the most direct routes, avoiding all obvious obstacles where possible.

2.3.4.1 Aboveground Piping Routes. Aboveground systems are generally lower in life-cycle costs but are less convenient in areas of heavy traffic. Consider blockage of access to areas for future development along with vulnerability to damage and acts of vandalism or sabotage.

Consider aboveground heat distribution systems for use in lieu of underground systems because of generally longer life and lower maintenance and use wherever operations and local conditions permit.

2.3.4.2 Buried Piping Routes. Select routing to allow for proper drainage of the system. Manholes and provision for piping expansion must be considered in space allocation. Consider minimum separation of parallel piping runs where temperatures in the runs vary widely. Consider cover and drainage provisions for manholes.

2.3.5 Economic Studies. Refer to NAVFAC P-442, Economic Analysis Handbook, for procedures in life-cycle cost analyses. Economic studies for all piping system types must include life-cycle (owning, operating, and maintenance) costs. For prefabricated/pre-engineered underground steam or hot water systems, perform the economic analysis, developing costs from heat loss data provided in Part 1 of Appendix A or from heat losses calculated from procedures provided in NFGS-02694. For concrete shallow trench systems of greater than 500-foot (152.5 m) length, use the additional procedures outlined in para. 2.3.6 and modify NFGS-02696 accordingly. Consider first an aboveground system, which, in most cases, will be economically advantageous to the Government. Also consider whether or not the facility is permanent or temporary. Provide a separate economic analysis for the selection of an insulation system among those allowed in NFGS-02696.

2.3.5.1 Annual Owning, Operating, and Maintenance Costs. Consider the following:

MIL-HDBK-1003/8A

a) Base selection of the distribution system and route on the results of life-cycle economic analyses of alternatives. Consider esthetics within the limits of the Station Master Plan.

b) Operation and maintenance costs depend on the type of system design and past experience with various systems.

2.3.5.2 Steam Versus High Temperature Water Distribution. For criteria on steam versus high temperature water distribution, refer to DM-3.6, Central Heating Plants. Some advantages and disadvantages of each system type are summarized on Table 2.

2.3.5.3 High-Pressure (above 50 psig) (344.5 kPa) Steam Versus Low-Pressure (0 to 15 psig) (0 to 103.4 kPa) Steam Distribution. Compare costs of higher pressure pipe, valve, and fitting standards against lower pressure standards plus costs of pressure reducing stations in selecting the most economical system. Low pressure steam may not require full-time boiler operator attendance. If operationally adequate, consider medium-pressure steam systems, 15 to 50 psig (103.4 to 344.5 kPa). End-use temperature requirements of terminal equipment must be met by the system selected.

2.3.6 Insulation for Shallow Trench Systems Which Exceed 500 Feet. If the estimated distribution line length exceeds 500 feet (152.5 m), determine the required insulation thickness as follows and edit NFGS-02693 as required.

2.3.6.1 Heat Loss Formula. For concrete shallow trench systems, perform the economic analysis with heat losses calculated using the following equation:

$$\text{Equation: } Q = 6.28(T_{rf} - T) / [1/r_p (r_p/r) / K_p + 1/r_i (r_i/r_p) / K_i + 0.5/r_i]$$

where:

r	=	inside radius of pipe, feet (one half of id)
r_p	=	outside radius of pipe, feet (one half of od)
r_i	=	radius of insulation, feet (one half of od)
T_{rf}	=	temperature of fluid, degrees F
T	=	temperature of ambient, degrees F (use 75)
K_p	=	steel pipe thermal conductivity, Btu-in/(hr)(sq-ft) (degrees F)
K_i	=	Insulation thermal conductivity, Btu-in/(hr)(sq-ft) (degrees F)
Q	=	pipe heat loss, Btu/hr (ft of pipe)

Table 2
Advantages and Disadvantages of Steam and
Hot Water Distribution Systems

STEAM SYSTEM ADVANTAGES

1. Smaller return pipe sizes are required.
2. Pumping costs for maintaining circulation are lower. Motor size is a fraction of that required for water, as is operating time in some cases.
3. Maintenance costs are lower. The small difference of pressure under which the system components operate reduces wear and maintenance expense to a minimum.
4. When the condensate is repeatedly recycled through the boiler and system, makeup water requirements and corrosion are negligible, and equipment life is lengthened.

STEAM SYSTEM DISADVANTAGES

1. Larger supply piping sizes are required.
2. Larger expansion loops, joints and swing connections are required.
3. Convectors and radiators must be installed in a pitched position.
4. Additional specialty items such as traps, lifts and in some cases pressure-reducing valves are required.
5. Condensate systems fail frequently, causing significant losses of heat.

Reference:
ASHRAE Handbook -
HVAC Systems and Applications

HOT WATER SYSTEM DISADVANTAGES

1. Fast, uniform response to instantaneous load changes using minimum pipe sizes.
2. Piping may be installed level or at any pitch.
3. Smaller supply pipe sizes are used.
4. Forced circulation provides, in the total water mass, the desirable inertia effect which helps to diversify system load requirements contributing to uniform input at fuel burners.
5. Requires fewer specialty items.
6. Permits practical air elimination to minimize corrosion and maintenance.
7. Resetting of system supply water temperature to meet changing loads permits more efficient energy usage.

HOT WATER SYSTEM DISADVANTAGES

1. Larger motor sizes are required for circulating pumps.
2. Larger return pipe sizes are required.
3. Expansion tanks and air vents are required.
4. More maintenance is required due to increased equipment wear caused by longer operating times.
5. More intricate controls may be required, to compensate for areas with frequent load variations, in order to keep system in balance.

Reference:
ASHRAE Handbook - Fundamentals

MIL-HDBK-1003/8A
Change 2, 30 December 1991

2.3.6.2 Heat Loss and Cost Relationship. To optimize the costs the designer must calculate the total owning and operating cost of different sections of the system, assuming use of one particular type of system configuration with various thicknesses of insulation. Only one type of system configuration needs to be considered because the optimum heat loss rate in a particular set of circumstances is not significantly different for different types of system configurations. As illustrated in Figure 1, the total owning and operating cost of a system is represented by a "U" shaped curve when cost is plotted against heat loss which is a function of insulation thickness. The curve is the sum of three other curves: the owning cost curve, which increases as heat loss increases; the maintenance cost curve, which is constant within limits regardless of heat loss; and the operating cost curve, which is directly proportional to the heat loss. The lowest point of the total cost curve is the minimum total owning and operating cost for the system, and the heat loss for the point is the optimum heat loss for the system. When total cost curves are generated for various types of system configurations for a particular site, the point of optimum heat loss is approximately the same for all the system configurations even though the total cost of owning and operating the different systems is different, as illustrated in Figure 2. Therefore, it is not necessary to calculate the insulation requirements for all types of system configurations.

2.4 Federal Agency Approved System Suppliers. The following list contains all approved system suppliers issued Federal Agency Letters of Acceptability required in NFGS-02694, Exterior Underground Heat Distribution System.

2.4.1 Class A, B, C, and D Ground Water Conditions.

- a) Intergy Systems, Brecksville, OH
- b) Perma Pipe, Niles, IL
- c) Rovanco Pipe, Joliet, IL
- d) E. B. Kaiser Company, Glenview, IL
- e) Pittcon Preinsulated Pipes, Inc., Syracuse, NY
- f) U. S. Polycon Corporation, Panama City, FL
- g) Nova Group, Inc., Napa, CA
- h) Thermacor Process, Inc., Fort Worth, TX
- i) Sigma Piping Company, Inc., Incline Village, NV

2.4.2 Class B, C, and D Ground Water Conditions.

- a) Thermal Pipe Systems, Media, PA

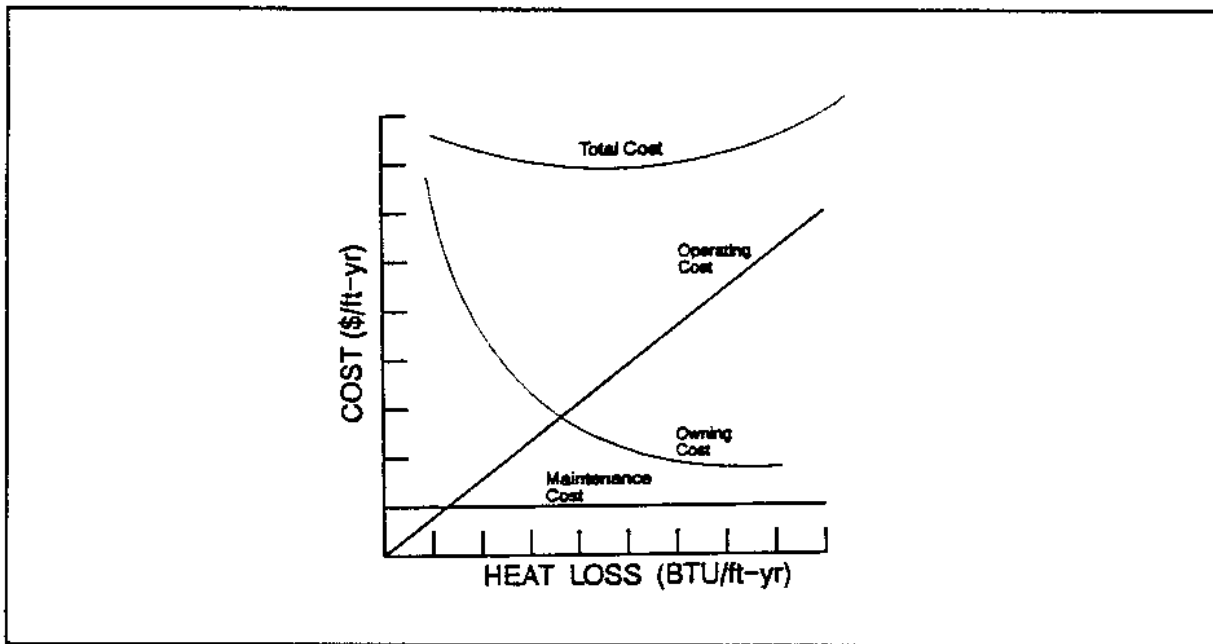

Figure 1
Relation Between Heat Loss and System Costs

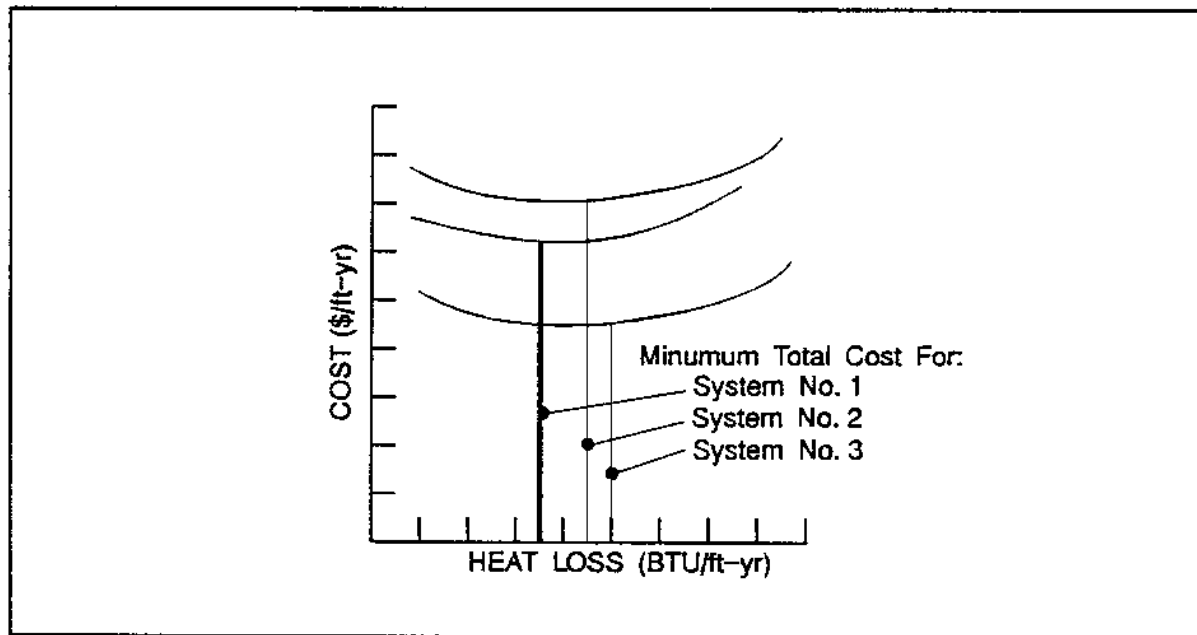

Figure 2
Total Cost of Owning and Operating Three Hypothetical Systems

MIL-HDBK-1003/8A

- Step 1. After the general layout of the system has been made and the site and application conditions have been determined, size the system carrier piping assuming a 2 percent heat loss from the supply line at maximum flow.
- Step 2. Select one particular type of system configuration which is relatively low in first cost and is approved for use with the site and application conditions identified, to use as a model in making the economic analysis.
- Step 3. Determine separately, for each section of the system, the installed cost per foot of the system configuration with each of the applicable combinations of insulation thicknesses shown in Table 3. A section can be considered as any portion of the system in which the conditions that affect heat loss are similar--e.g., pipe size, tunnel shape, cover type. The cost of all components, other than valve vaults called for in the selected system should be included in the cost estimate. If only one pipe is to be installed (i.e., either a supply or return, but not both), use only the appropriate column from the table for that type of pipe.
- Step 4. Determine the annual owning cost per foot of each section of the system with each of the different thicknesses of insulation called for in Table 3, using the following equation:

$$\text{Owning Cost (\$/ft-yr)} = \frac{\text{Installed Cost (\$/ft)}}{\text{*Series Present Worth Factor}}$$

*The series present worth factor is the reciprocal of the capital recovery factor.

The series present worth factor can be obtained from any set of interest tables, given the annual interest rate (or rate of return) and the number of years over which the cost is to be amortized (i.e., the economic life of the item). Use an economic life of 25 years and a discount rate as published in National Bureau of Standards (NBS) Handbook 135, entitled Life Cycle Cost Manual for the Federal Energy Management Program.

- Step 5. Calculate the heat loss per linear foot separately for each pipe in each section of the selected model system, assuming the various thicknesses of insulation called for in Table 3, using applicable calculation procedures in para. 2.3.6.1.

MIL-HDBK-1003/8A
Change 2, 30 December 1991

Table 3
Insulation Thickness (in inches) to be Assessed in Calculations

Thermal Conductivity of Insulation	WITH HIGH TEMPERATURE WATER (above 250 degrees F)		WITH LOW TEMPERATURE WATER (250 degrees F and lower)		WITH STEAM (any pressure)	
	On the Supply Pipe	On the Return Pipe	On the Supply Pipe	On the Return Pipe	On the Supply Pipe	On the Condensate Pipe
(Btu/hr, square feet, degrees F/in.)						
Up to 0.2	1/2	1/2	1/2	0	1/2	0
	1	3/4	1/2	1/2	1/2	1/2
	1	1	1	1/2	1	0
	1-1/2	1	1	3/4	1	3/4
	1-1/2	1-1/2	1-1/2	3/4	1-1.2	0
	-	-	1-1/2	1	1-1/2	1
From 0.2 to 0.4	3/4	3/4	3/4	0	3/4	0
	1-1/2	1	3/4	3/4	3/4	3/4
	1-1/2	1-1/2	1-1/2	3/4	1-1/2	0
	2-1/2	2	1-1/2	1	1-1/2	3/4
	2-1/2	2-1/2	2	1	2-1/2	0
	-	-	2	1-1/2	2-1/2	1-1/2
From 0.4 to 0.6	2	2	2	0	2	0
	3	2	2	2	2	2
	3	3	3	2	3	0
	4	3	3	3	3	2
	4	4	4	2	4	0
	-	-	4	4	4	2
Above 0.6	3	3	3	0	3	0
	4	3	3	3	3	3
	4	4	4	3	4	0
	5	3	4	4	4	3
	5	5	5	3	5	0
	-	-	5	4	5	3

MIL-HDBK-1003/8A
Change 2, 30 December 1991

Section 3: GENERAL DESIGN FACTORS

3.1 Design Responsibilities for Underground Pre-engineered Heat Distribution Systems. The project designer is responsible for accomplishing the following prior to project bidding:

a) Define site conditions for underground water classification (A, B, C, or D), soil corrosiveness, soil pH if less than 5.0, and potential soil load bearing problems.

b) Determine the general layout and essential characteristics of the system such as system media, maximum operating temperature and pressure, location and design of manholes, and branch runouts. The interface detail of the system at manhole walls shall be provided by the system supplier.

c) Design special elements of the system as required.

d) Calculate the maximum heat loss per lineal foot of the conduit in accordance with the procedures outlined in NFGS-02694.

3.1.1 Design by Project Designer. The project designer shall design on project drawings the exterior steam and condensate piping systems aboveground, the manholes, piping within manholes, and piping not in approved conduit systems. The project designer shall establish the system design parameters of the entire underground piping system, such as site classification, general layout, essential characteristics of the system, and specially designed elements of the system. The project designer is responsible for sizing the pipe, establishing the piping elevations, identifying the piping right-of-way, obstructions and utilities (plan and profile) within 25 feet (7.62 m) of the center line of the right-of-way, and every area within 25 feet of the center line that must be avoided; for example, paved areas and buildings. The project designer is also responsible for the location and sizing of manholes, the design of concrete manholes and the piping and equipment layout of manholes including valves, fittings, traps, expansion joints (when required), and manhole drains.

3.1.2 Design by System Supplier. The construction Contractor shall design and provide buried factory-prefabricated preinsulated piping in a conduit or pre-engineered insulated piping system for which a Federal Agency Approved Brochure has been issued. It is intended that the supplier of a Federal Agency approved system provide the details of design for his system in accordance with his Federal Agency Approved Brochure. The preapproved brochure and the design will address expansion loops, bends, offsets, concrete pipe anchors outside of manholes, interface with each manhole, and the watershed to aboveground piping. When prefabricated steel manholes are indicated, the system supplier is responsible for the structural design of the manhole and the manufacture of the complete manhole, including installation of valves, fittings, and other equipment as specified herein and indicated on the project

MIL-HDBK-1003/8A

drawings. The Contractor is responsible for the design, fabrication, and installation of the underground piping system within the system design parameters established by the project designer.

3.2 Distribution Site Location. Fluid distribution site locations should be according to the following:

3.2.1 Location Factors. For location factors for each system, refer to Table 4.

3.2.2 Subsurface Explorations. When a concrete trench or a buried steam or hot water system is specified, make a thorough investigation of ground and water conditions shall be made. Employ a soils engineer familiar with ground water conditions at the site to establish the classification. In the absence of existing definitive information on soil types and ground water conditions, make a detailed site classification survey. Upon completion of the survey, classify each exploration point as A, B, C, or D on the basis of the criteria presented in Tables 5 and 6. The worst ground water condition encountered between adjacent manholes determines the class of the system to be installed between adjacent manholes. Conduct this survey within the guidelines specified in paras. 3.2.2.1 through 3.2.2.12. When concrete shallow trench systems are specified, use the criteria of NFGS-02693 for prefabricated piping systems covered in this handbook.

3.2.2.1 Timing of Survey. Conduct the survey after the general layout of the system has been determined.

3.2.2.2 Time of Year. Make the survey at a time of year when the highest water table is expected to exist, if possible. If this is not possible, correct water table measurements on the basis of professional judgment, to indicate conditions likely to exist at the time of year when the water table is at its highest point. Follow exploration methods indicated in the NAVFAC criteria manual DM-7.01, Soil Mechanics.

3.2.2.3 Exploration Considerations. As a minimum, collect information on ground water conditions, soil types, terrain, and precipitation rates and irrigation practices in the area of the system. Information on terrain and precipitation rates and irrigation practices may be obtained from available records at the installation.

3.2.2.4 Test Explorations. Make test explorations (borings or test pits) at least every 100 feet (30.5 m) along the line of a proposed system. If changes in stratification are noted, decrease the boring spacings so an accurate horizontal soil profile may be obtained.

MIL-HDBK-1003/8A

MIL-HDBK-1003/8A

Table 4
Location Factors for Each Distribution System

ITEM	DETERMINE THE FOLLOWING
Load Centers	<p>Maximum demand load of system. (See criteria in Table 1 and ascertain requirements of all facilities.)</p> <p>Distance from generating plant.</p> <p>Basements or crawl spaces under buildings available for piping.</p> <p>Location of entry of system to load center structure.</p> <p>Location or need of meters for billing purposes.</p> <p>Future expansion.</p>
Route	<p>Existing piers, tunnels or trenches available for system.</p> <p>Aboveground obstructions, such as rivers, lakes, roads, railroads, structures, etc.</p> <p>Belowground obstructions, such as tunnels, trenches, piping, rock, storage tanks, etc.</p> <p>Location of expansion loops, joints and manholes.</p> <p>Master Plan. (Refer to DM-1.01)</p>
Site	<p>For above and underground systems: Ground contours along route.</p> <p>For underground systems:</p> <p>Borings every 100 feet along route (refer to para 3.1.2) - longer for larger projects.</p> <p>Absorption test (refer to para 3.1.2.5)</p> <p>Resistivity test (refer to para 3.1.2.7)</p> <p>Stability of soil (refer to para 3.1.2.8)</p> <p>Water table survey made at time of highest levels if possible, or modify by judgement based on local data.</p> <p>Maximum, normal, and minimum groundwater levels.</p> <p>Frost level.</p> <p>Location of distribution line drainage and venting.</p>
Coordination	<p>Installation of other related distribution systems and manholes.</p> <p>Interference with electric distribution lines and manholes.</p> <p>Interference with water supply and fire extinguishing systems.</p> <p>Interference with sanitary and storm sewers and manholes.</p> <p>Interface with communications systems.</p> <p>Interference with ground drainage lines, catch basins, and manholes.</p> <p>Interference with fuel distribution piping systems.</p> <p>Interface with other gas supplies such as argon, nitrogen and carbon dioxide used in industrial process work.</p> <p>Excavation and backfill.</p> <p>Landscaping.</p>
Cooperation	Local rules and regulations (permits, tests approvals, etc.).
Hazards	Refer to DM-1.01 for criteria.
Unit costs	<p>Excavation of soil and rock and of landfill.</p> <p>Piping material.</p> <p>Piping insulation or covering.</p> <p>Pipe conduit.</p> <p>Construction of manholes.</p> <p>Construction of expansion loops and field joints.</p>
Local labor	Availability and costs.
Local material	Availability and costs.

MIL-HDBK-1003/8A

Table 5
Soil Classification

FIELD IDENTIFICATION PROCEDURES (Excluding particles larger than 3 inches and basing frictions on estimated weights)		GROUP SYMBOLS	TYPICAL NAMES	PERMEABILITY WHEN COMPACTED
COURSE GRAINED SOILS More than half of material is larger than No. 200 sieve size (The No. 200 sieve size is about the smallest particle visible to the naked eye)	FINE GRAINED SOILS More than half of material is smaller than No. 200 sieve size (The No. 200 sieve size is about the smallest particle visible to the naked eye)			
GRAVELS More than half of coarse fraction is larger than No. 4 sieve size. (For visual classifications, the 1/4" size may be used as equivalent to the No. 4 sieve size.)	SANDS WITH FINES (Appreciable amount of fines)	GW	Well graded gravels, gravel-sand mixtures, little or no fines.	Pervious
GRAVELS WITH FINES (Appreciable amount of fines)	GRAVELS WITH FINES (Appreciable amount of fines)			
GRAVELS More than half of coarse fraction is smaller than No. 4 sieve size (For visual classifications, the 1/4" size may be used as equivalent to the No. 4 sieve size.)	CLEAN SANDS (Little or no fines)	GP	Poorly graded gravels, gravel-sand mixtures, little or no fines.	Very Pervious
GRAVELS WITH FINES (Appreciable amount of fines)	GRAVELS WITH FINES (Appreciable amount of fines)			
GRAVELS More than half of coarse fraction is smaller than No. 4 sieve size (For visual classifications, the 1/4" size may be used as equivalent to the No. 4 sieve size.)	CLEAN SANDS (Little or no fines)	GM	Silty gravels, poorly graded gravel-sand mixtures.	Semi-pervious to impervious
GRAVELS WITH FINES (Appreciable amount of fines)	GRAVELS WITH FINES (Appreciable amount of fines)			
GRAVELS More than half of coarse fraction is smaller than No. 4 sieve size (For visual classifications, the 1/4" size may be used as equivalent to the No. 4 sieve size.)	CLEAN SANDS (Little or no fines)	GC	Clayey gravels, poorly graded gravel-sand mixtures.	Impervious
GRAVELS WITH FINES (Appreciable amount of fines)	GRAVELS WITH FINES (Appreciable amount of fines)			
GRAVELS More than half of coarse fraction is smaller than No. 4 sieve size (For visual classifications, the 1/4" size may be used as equivalent to the No. 4 sieve size.)	CLEAN SANDS (Little or no fines)	SW	Well graded sands, gravelly sands; little or no fines	Pervious
GRAVELS WITH FINES (Appreciable amount of fines)	GRAVELS WITH FINES (Appreciable amount of fines)			
GRAVELS More than half of coarse fraction is smaller than No. 4 sieve size (For visual classifications, the 1/4" size may be used as equivalent to the No. 4 sieve size.)	CLEAN SANDS (Little or no fines)	SP	Poorly graded sands, gravelly sands; little or no fines.	Pervious
GRAVELS WITH FINES (Appreciable amount of fines)	GRAVELS WITH FINES (Appreciable amount of fines)			
GRAVELS More than half of coarse fraction is smaller than No. 4 sieve size (For visual classifications, the 1/4" size may be used as equivalent to the No. 4 sieve size.)	CLEAN SANDS (Little or no fines)	SM	Silty sands, poorly graded sand-silt mixtures	Semi-pervious to impervious
GRAVELS WITH FINES (Appreciable amount of fines)	GRAVELS WITH FINES (Appreciable amount of fines)			
GRAVELS More than half of coarse fraction is smaller than No. 4 sieve size (For visual classifications, the 1/4" size may be used as equivalent to the No. 4 sieve size.)	CLEAN SANDS (Little or no fines)	SC	Clayey sands, poorly graded sand-clay mixtures	Impervious
GRAVELS WITH FINES (Appreciable amount of fines)	GRAVELS WITH FINES (Appreciable amount of fines)			
IDENTIFICATION PROCEDURES ON FRACTION SMALLER THAN No. 40 SIEVE SIZE		ML	Inorganic silts and very fine sands, rock, flour, silty or clayey fine sands with slight plasticity.	Semi-pervious to impervious
IDENTIFICATION PROCEDURES ON FRACTION SMALLER THAN No. 40 SIEVE SIZE				
IDENTIFICATION PROCEDURES ON FRACTION SMALLER THAN No. 40 SIEVE SIZE		CL	Inorganic clays of low to medium plasticity, gravelly clays, sandy clays, silty clays, lean clays.	Impervious
IDENTIFICATION PROCEDURES ON FRACTION SMALLER THAN No. 40 SIEVE SIZE				
IDENTIFICATION PROCEDURES ON FRACTION SMALLER THAN No. 40 SIEVE SIZE		OH	Organic silts and organic silts-clays of low plasticity.	Semi-pervious to impervious
IDENTIFICATION PROCEDURES ON FRACTION SMALLER THAN No. 40 SIEVE SIZE				
IDENTIFICATION PROCEDURES ON FRACTION SMALLER THAN No. 40 SIEVE SIZE		MH	Inorganic silts, micaceous or diatomaceous fine sandy or silty soils, elastic silts	Semi-pervious to impervious
IDENTIFICATION PROCEDURES ON FRACTION SMALLER THAN No. 40 SIEVE SIZE				
IDENTIFICATION PROCEDURES ON FRACTION SMALLER THAN No. 40 SIEVE SIZE		OH	Inorganic clays of high plasticity, fat clays	Impervious
IDENTIFICATION PROCEDURES ON FRACTION SMALLER THAN No. 40 SIEVE SIZE				
IDENTIFICATION PROCEDURES ON FRACTION SMALLER THAN No. 40 SIEVE SIZE		OH	Organic clays of medium to high plasticity.	Impervious
IDENTIFICATION PROCEDURES ON FRACTION SMALLER THAN No. 40 SIEVE SIZE				
HIGHLY ORGANIC SOILS Readily identified by color, odor, spongy feel and frequently by fibrous texture.		Pt	Peat and other highly organic soils	Impervious
HIGHLY ORGANIC SOILS Readily identified by color, odor, spongy feel and frequently by fibrous texture.				

MIL-HDBK-1003/8A

Table 6
Site Classification Criteria

Site Class	General Conditions Required for such Classification	Conditions Found During Site Classification Survey that are Indicative of the Class			
		Relative to Water Table Level	Soil Types	Terrain	Precipitation Rates or Irrigation Practices in Area
A--Severe	Water table frequently above bottom of the system	Groundwater within 1 ft of bottom of system	Any	Any	Any
	Water table occasionally above bottom of the system and surface water accumulates and remains for long periods of soil surrounding the system	Groundwater within 1 ft of bottom of system	GC, SC, CL, CH, OH	Any	Any
B--Bad	Water table occasionally above bottom of the system and surface water accumulates and remains either for short periods in soil surrounding the system	Groundwater within 5 ft of bottom of system	GW, GP, SW, SP	Any	Any
	Water table never above the bottom of the system, but surface water accumulates and remains for long periods in soil surrounding the system	No groundwater encountered	GM, SM, ML, OL, MH	Any	Equivalent to 3 in. or more in any one month or 20 in. or more in one year
C--Moderate	Water table never above the bottom of the system, but surface water accumulates and remains for short periods in soil surrounding the system	No groundwater encountered	GC, SC, CL, CH, OH	Any	Equivalent to 3 in. or more in any one month or 20 in. or more in one year
	Water table never above the bottom of the system and surface water does not accumulate and remain in soil surrounding the system	No groundwater encountered	GM, SM, ML, OL, MH	Any	Equivalent to 3 in. or more in any one month and to less than 20 in. in one year
D--Mild	Water table never above the bottom of the system and surface water does not accumulate and remain in soil surrounding the system	No groundwater encountered	GC, SC, CL, CH, OH	Any except low areas	Equivalent to less than 3 in. in any one month and to less than 20 in. in one year
		No groundwater encountered	GW, GP, SW, SP	Any	Any
			GM, SM, ML, OL, MH	Any except low areas	Equivalent to less than 3 in. in any one month and to less than 20 in. in one year

MIL-HDBK-1003/8A

3.2.2.5 Depth of Exploration. Extend all explorations 5 ft (1.53 m) below the expected elevation of the concrete trench invert or the depth of the pre-engineered system to determine ground water conditions.

3.2.2.6 Special Ground Considerations. Give particular attention to the following conditions:

a) The possibility that the ground below a backfilled piping system may not be able to absorb runoff that has seeped into it.

b) Areas where ponding may occur, either along a sloping surface or in low flat areas.

c) The permeability of the ground below the system (see below).

3.2.2.7 Permeability Tests. Perform field permeability tests as follows:

a) Space field permeability tests (percolation) along the line of a trench at intervals of approximately 100 feet (30.5 m). When available information indicates uniform subsurface conditions, longer intervals may be allowed for larger projects.

b) Dig holes approximately 1 foot² (0.093 m²) to a depth of 2 feet (620 mm) below the approximate bottom of a trench.

c) Fill each hole with water to the bottom elevation of the planned trench.

d) After the water has completely seeped away, immediately refill each hole with water to the same depth.

e) If it requires 20 minutes or less for the water to drop 2 inches (51 mm), consider the soil dry; otherwise, consider it as saturated at times.

3.2.2.8 Test Results. Use test results as follows:

a) If the soil is saturated, no further tests are required. Class A underground conduit systems for wet soils must be used.

b) If the soil is dry, as defined above, deepen permeability test holes an additional 3 feet (920 mm) to determine if the water table is within 5 feet (1.53 m) of the trench bottom.

3.2.2.9 Soil Resistivity. Considerations for soil resistivity are as follows:

MIL-HDBK-1003/8A

a) Take soil resistivity readings along the conduit line (in accordance with Table 4).

b) A cathodic protection system is required to protect metallic piping systems and manholes. This applies to all sites where soil resistivity is less than 30,000 ohms per cubic centimeter (ohm-cm), where stray direct currents can be detected underground or where underground corrosion, due to local soil conditions, has been found to be severe.

3.2.2.10 Soil Corrosiveness Classification. Have an experienced corrosion engineer make the classification based on a field survey of the site carried out in accordance with recognized guidelines for conducting such surveys. Classify the soil at the site as corrosive or noncorrosive on the basis of the following criteria:

a) Corrosive: The soil resistivity is less than 30,000 ohms-centimeter (ohm-cm) or stray direct currents can be detected underground.

b) Noncorrosive: The soil resistivity is 30,000 ohm-cm or greater and no stray direct currents can be detected underground.

3.2.2.11 Soil Stability. During the above survey, observe and note the soil stability. Use NAVFAC DM-7.01 for criteria. Note areas of unstable soil on the site plans depicting the distribution route.

3.2.2.12 Soil Load-Bearing Capacity. As a part of the project designer's survey, have an experienced soils engineer investigate the load-bearing qualities of the soil in which the system will be installed. Identify the location and nature of potential soils problems. Depending on the nature of the problem, the designer may choose to reroute the line, use a combination of concrete shallow trench, direct buried, or aboveground low-profile systems, or elect to over-excavate and replace with nonexpensive fill.

3.2.3 Site Classification. Base selection of the conduit system type on the underground water conditions at the project site as defined in Tables 4, 5, and 6 for Class A, B, C, or D application corresponding to underground water conditions ranging from severe to mild, respectively.

3.2.3.1 Class A, Severe. The water table is expected to be frequently above the bottom of the system or the water table is expected to be occasionally above the bottom of the system and surface water is expected to accumulate and remain for long periods in the soil surrounding the system.

3.2.3.2 Class B, Bad. The water table is expected to be occasionally above the bottom of the system and surface water is expected to accumulate and remain for short periods (or not at all) in the soil surrounding the system or the water table is expected never to be above the bottom of the system but

surface water is expected to accumulate and remain for long periods in the soil surrounding the system.

3.2.3.3 Class C, Moderate. The water table is expected to never be above the bottom of the system, but surface water is expected to accumulate and remain for short periods in the soil surrounding the system.

3.2.3.4 Class D, Mild. The water table is expected never to be above the bottom of the system and surface water is not expected to accumulate or remain in the soil surrounding the system.

3.2.4 Analyzing Site Classification for Application of Pre-Engineered Underground System. The Federal Agency Committee on Underground Heat Distribution Systems has reviewed and approved systems by suppliers. Each system is defined in the brochure approved by the Committee. No system may be installed without prior approval as given in the brochure. The letter of certification contained in the conduit system brochure stipulates the approved site classification. A system approved for higher classification is acceptable for use in lower classifications. For example, Class A is acceptable for Classes B, C, and D, etc.

3.2.5 Analyzing Site Classification for Application of Shallow Concrete Trench System

3.2.5.1 Soils

a) Fine grained soils (impervious). The highest ground water level evident during the wettest period of the year should be a minimum of 1 foot (305 mm) below the lowest point of water entry into the concrete shallow trench system. The lowest point of entry is defined as the joint between the concrete trench wall and concrete trench bottom. The concrete trench bottom will be continuous with no openings. The above condition will ensure that constructability of the concrete shallow trench is practical and that potential infiltration of water into the shallow trench will be negligible. Open drainage ways, swales, or swampy/boggy areas will preclude use of a concrete shallow trench system because of ground water level guidance in Table 5. The concrete shallow trench system must be rerouted or regraded to bring the concrete trench out of the unsuitable conditions. Have the geotechnical engineer who performed the detailed site classification survey provide regrading instructions. The designer will ensure that the fill will remain stable and will not be subject to future wash-outs. If the specific site conditions are such that these alternatives are not viable, consider aboveground low profile or a direct buried system of the prefabricated or preengineered type in accordance with NFGS-02694 for these areas.

b) Coarse grained soils (semipervious/pervious). The ground water level during the wettest period of the year should be at least 1 foot (305 mm) below the lowest point of water entry into the concrete shallow trench system.

MIL-HDBK-1003/8A

(1) Water table located 1 to 2 feet (305 to 610 mm) below lowest point of water entry. The criteria of para. 3.2.5.1 a) applies.

(2) Water table located 2 or more feet below lowest point of water entry: Concrete shallow trench systems with noncontinuous bottom (tunnel constructed of noncontinuous concrete bottom with openings provided in bottom at intervals of 4 feet (1220 mm) or more to permit drainage into the semipervious/pervious soils) may be used. Special considerations are required when the concrete shallow trench would traverse open drainage ways or swales where the water table would be less than 2 feet (610 mm) below the concrete trench bottom. The designer may elect to reroute the system, place fill to bring the system out of the unsuitable conditions, or provide a continuous bottom trench floor for this area of the site.

c) Swelling Soils (material with high swell potential): If the specific site conditions are such that these alternatives are not viable, consider aboveground low profile or a direct buried system of the prefabricated or preengineered type in accordance with NFGS-02694 for those areas. Design the concrete shallow trench system in materials having high swell potential in accordance with para. 3.2.5.1 a). Soils having a liquid limit (LL) greater than 50 and a plasticity index (PI) greater than 25 require testing (consolidation swell) to determine the swell characteristics. When the results of the swell test indicate high swell potential, special considerations such as over excavation (width and depth) and replacement with nonexpansive fill, under-trench drainage system or other methods of minimizing differential heave will be provided. The design of special features such as described above will be in accordance with instructions provided by the geotechnical engineer who performed the detailed site classification survey. Design of joint spacing and joint details to accommodate movements will also be provided when required.

3.2.5.2 Settlement of Trenches. Generally, settlement of concrete trenches will not be a problem since the unit load of the shallow trench system will be similar to the existing unit overburden load. Backfill adjacent to the concrete trench must be thoroughly compacted to prevent settlement which would create ponding. Positive slopes away from the concrete trench are desirable. Special care of backfill and compaction is required where the system crosses existing streets to preclude settlement and cracking of the roadway adjacent to the trench from repeated traffic loads.

3.2.5.3 Under-Trench Drainage Systems. Use concrete trench subdrain systems as required. When subsurface conditions are of differing soil types, (fine grained and coarse grained) and those differing soil conditions will cause blocked drainage either horizontally or vertically adjacent to the concrete trench, provide subdrains to ensure drainage to prevent ponding or entrapment of water adjacent to the shallow trench system. Base the design of the subdrain system on the instructions provided by the geotechnical engineer who performed the detailed site classification survey and classified each

MIL-HDBK-1003/8A

exploration point. Soils of low permeability and high moisture content (lean and fat clays (CL-CH)) shall not require under-drains when the shallow trench system is designed to accommodate all anticipated inflow with systems or equipment such as direct connections to storm sewers or the use of dual sump pumps. Connect drainage system sump pump discharge pipes to storm sewer system where feasible. If not feasible, provide discharge to splash blocks on grade. When discharging to grade install the pump discharge line without a check valve to allow complete drainage of the discharge pipe to prevent freezing. Do not use under-trench drainage to alter ground water level to meet requirements of Table 5.

3.2.6 Reinforced Thermosetting Resin Plastic (RTRP) Pipe. RTRP pipe is normally supplied under Mil Spec. MIL-P-28584, when used for condensate systems. This pipe is suitable for service pressures up to 150 psig (1034 kPa) and temperatures up to 200 degrees F (93 degrees C). Above 200 degrees F (93 degrees C) the pressure rating drops off rapidly. At 250 degrees F (121 degrees C) the pressure rating is 125 psig (861.3 kPa) and drops to 45 psig (310.1 kPa) at 270 degrees F (132 degrees C). These ratings are for hot water. Live steam cannot be tolerated, although RTRP pipe may be used for vented gravity condensate piping as well as for pumped condensate piping. RTRP pipe is acceptable at Class B sites (refer to para. 3.2.3). It is recommended for Class A sites, as permitted in para. 2.1.2, due to its low cost and long service life. Procure and install RTRP condensate piping in accordance with NFGS-02697. Take special care in the design of steam drip connections to protect the RTRP piping from live steam from failed traps. Insulate condensate piping only when a life-cycle cost analysis indicates a payback in energy savings, or where needed for personnel protection (manholes, for example).

3.3 Service and Loads. Determine from Section 2 the services, such as steam, high temperature water, hot water, chilled water, compressed air, fuel gas and others, required for each load center or building, the load demands for each service, and the capacity of a source or central plant for each service. (Refer to Section 2 for fluid conditions inside service lines, for sizing pipes for these conditions, and for the required capacities.)

3.3.1 Alternate Routes. Refer to Master Plan and consider system routing and size to accommodate future construction.

3.3.2 Pressure Drop. From the total allowable pressure drop and ultimate length of a line, determine the pressure drop per 100 feet (30.5 m). Note the maximum flow between each load center and size the different pipeline sections accordingly.

3.3.3 Obstacles. From a field survey, note all obstacles for each route.

3.3.4 Future Loads. Refer to Master Plan and consider system routing to accommodate future construction.

MIL-HDBK-1003/8A

3.3.5 Distribution Circuits. Select a circuit which is economical, easy to operate, balance and control, and is suitable for a particular project terrain. Note that types easiest to balance and control are those where pressure and temperature differences are fairly constant between equipment supply and return branches.

3.3.6 Route Types. Run distribution piping through buildings, aboveground, or underground and below piers.

3.3.6.1 Through Buildings. Select the route considered technically and economically best justified; make full use of building piers, underpiling spaces, basements, crawl spaces, and attics, including connecting corridors between buildings, existing tunnels and concrete trenches. However, high-pressure fuel gas, steam, and HTW piping inside buildings should be routed to comply with federal and local fire and life safety codes. Gas piping shall comply with ANSI B31.8, Gas Transmission and Distribution Piping Systems, and NFPA 54, National Fuel Gas Code. Steam, condensate and compressed air lines shall comply with ANSI B31.1, Power Piping.

3.3.6.2 Exterior Steam Distribution. Use NFGS-02695 for all steam distribution piping exposed to the weather, on building exteriors, aboveground piping supports, piers (pedestals), poles, and for all steam piping on piers and under piers, in tunnels and in manholes. Use NFGS-02693 for piping in trenches. Use NFGS-02694 for buried steam piping .

3.3.6.3 Aboveground Overhead Piping. Locate piping as low as 1 foot (305 mm) or as high as 22 feet (6.7 m) above the ground surface. A 16-foot (4.9 m) clearance is required for automobile and truck traffic, and a 22-foot (6.7 m) clearance for railroad cars.

3.3.6.4 Buried Piping. For buried piping routes, the following criteria apply (refer to NFGS-02694):

a) Compressed Air and Gas Piping. Compressed air and gas piping generally require no insulation, but they should be shop coated, wrapped, tested, and handled in accordance with provisions of NFGS-02685, Exterior Buried Natural Gas Distribution Systems, NFGS-02682, Exterior Fuel Distribution System), and NFGS-09809, Protection of Buried Steel Piping and Steel Bulkhead Tie Rods. Provide for testing of coverings by electrical flow detectors (spark test).

b) Minimum Cover. Protect all buried piping and conduits by laying them under a minimum cover of 24 inches (610 mm). However, protect buried piping under railroads, roads, streets, or highways or due to changes in ground contours against possible external damage due to the superimposed car or truck traffic. Lay pipes below the frost line. Casings may be needed where there is no frost.

MIL-HDBK-1003/8A

c) Other Hazards. When piping must be laid where it will be subjected to hazards such as earthquakes, washouts, floods, unstable soils, landslides, dredging of water bottoms and other categorically similar conditions, protect it by increasing pipe wall thickness, constructing intermediate supports or anchors, erosion prevention, covering pipes with concrete, adding seismic restraints for above-grade piping or other reasonable protection.

d) Manholes. Select manhole locations in accordance with the following. Details of piping and design of manholes are the responsibility of the project designer. Design manholes to provide adequate space for maintenance, proper venting and quick egress. Manholes are required where vertical offsets in steam piping are required to conform to grading requirements. Manholes accommodate the required steam main drip traps and any block valves needed. Manholes are usually provided at all major branch line connections and at drip traps on compressed air lines.

e) Tunnels. Construct tunnels for underground routes with a walkway minimum height of 76 inches (1.93 m) and clear width of 36 inches (920 mm), with piping stacked vertically on one side and enlarged zones for crossovers and takeoffs. Label all pipes and conduit. Provide enough room to reach all flange bolts, to operate tools, and to operate or to replace any component. Run a drainage trench along one wall to a point of disposal such as a storm sewer or a sump pit, with an automatic drainage pump driven by an electric motor or steam jet. Install all electrical systems in rigid metal conduit. Identify and separate by voltage class. Tunnels shall be well lighted and ventilated. Use moisture resistant electrical fixtures. Tunnels may be built of reinforced concrete, brick, or other suitable structural materials, and shall be membrane waterproofed.

3.3.6.5 Condensate Return Cost. Refer to para. 4.1.2 and 4.2.2.3.

3.3.6.6 Choice of Route. Except in congested and vulnerable areas, choose aboveground routes for heat distribution systems. Otherwise, adapt site conditions to comparative advantages of going above or underground as stated below:

MIL-HDBK-1003/8A

Aboveground	Underground
Lower first cost	Less heat loss on hot lines Less vulnerable target
Less maintenance	Less obstruction to aboveground traffic
Easy detection of failure	Less unsightly
Higher continuous operating efficiency	Freeze protected when buried
Longer life	Less heat gain in chilled and condenser water piping

3.3.6.7 Piping Layouts. The project designer is responsible for determining location of expansion bends, loops and joints, anchors, takeoffs, isolation valves, and drip points. The project designer is also responsible for locating all manholes, takeoffs, isolation valves, and drip points. The system designer determines the initial location of anchors, expansion bends, loops and joints; the system supplier determines final location and design of these features to fit actual field conditions. Plan and position piping layouts as follows:

a) Determine what lines between the same points should be parallel to each other (such as supply and return) or be separated (such as steam from chilled water). The minimum clearance between pipe conduits in the same trench shall be 6 inches (150 mm).

b) Determine locations of expansion bends or loops, anchors, takeoffs, and drip points. In non-pre-engineered/prefabricated heat distribution systems, the project designer is responsible for determining location of expansion bends, loops and joints; anchors; takeoffs; isolation valves; and drip points. In pre-engineered/prefabricated heat distribution systems, the project designer is responsible for locating all manholes, takeoffs, isolation valves and drip points. Initial location of anchors, expansion bends, loops and joints shall be by the system designer. The system designer determines the initial location of anchors, expansion bends, loops and joints; the system supplier determines final location and design of these features to fit actual field conditions.

c) Lay out piping on a scaled contour map of the site and on a profile drawing along the route, locating all obstructions and interferences, such as streams, roads, railroads, buried tunnels, concrete trenches, drainage piping, sewers, water piping, electrical conduits, and other service piping, within 25 (7.6 m) feet of the center line of the right-of-way and identify areas within 25 feet of the center line that must be avoided. If sufficient

MIL-HDBK-1003/8A

right-of-way to accommodate pipe expansion cannot be identified and expansion joints are required, they must be specified and located with installation details noted on the drawings.

d) Provide a log of soil conditions along the piping right-of-way which gives, as a minimum, soil type, soil resistivity and pH, bearing strength and unstable conditions, and indicate corrective work required.

e) Provide details at building entries on the project drawings to show pipe elevation, floor elevation, building wall construction, and existing equipment.

3.3.6.8 Underground. Use only approved and certified conduit systems for steam, condensate and HTW, and procure and install in accordance with the requirements of NFGS-02694, NFGS-02697, and NFGS-02698, respectively. The Federal Agency Committee for Underground Heat Distribution Systems approves and certifies the various types of conduit systems, i.e., drainable and dryable (pressure testable), sectionalized, prefabricated (non-pressure testable), and poured-in-place granular insulation type conduit systems. Concrete shallow trench systems may be used only if the soil characteristics set forth in NFGS-02693 are met. In this case, design and specify the system in accordance with NFGS-02693.

3.4 Insulation. Evaluate insulation for all piping systems with the potential for significant thermal losses. These include steam, condensate, HTW, MTW, LTW, and CHW piping. Use NFGS-15250, Insulation of Mechanical Systems, for CHW, LTW and special applications requiring insulation of fuel gas and compressed air piping systems. Use NFGS-02696 for above-grade steam, HTW, MTW, LTW, and condensate return piping systems. (Alternately, NFGS-15250 may be used for these above-grade piping systems.) Use aluminum jackets and organic felt as specified in NFGS-15250 and NFGS-02696. Use NFGS-02694 for underground heat distribution piping insulation. Insulation materials shall not contain asbestos.

3.5 Miscellaneous Criteria. Anchor or guy exterior distribution systems to withstand the wind velocity specified for design of structures, refer to MIL-HDBK-1002/2, Loads.

MIL-HDBK-1003/8A

Section 4: SPECIFIC PIPING DESIGN FACTORS

4.1 Fluid Characteristic

4.1.1 Steam. Refer to Keenan and Keyes, Thermodynamic Properties of Steam.

4.1.2 Condensate. For the economics of returning condensate, use the American Society of Heating, Refrigerating, and Air Conditioning Engineers (ASHRAE) 1985 Handbook - Fundamentals and ASHRAE 1987 Handbook - HVAC Systems and Applications.

4.1.3 High Temperature Water (HTW), Medium Temperature Water (MTW), and Low Temperature Hot Water (LTW). Use ASHRAE 1985 Handbook - Fundamentals and ASHRAE 1987 Handbook - HVAC Systems and Applications.

4.1.4 Compressed Air. For data on compressed air, refer to DM-3.5, Compressed Air and Vacuum Systems.

4.1.5 Natural Gas. Refer to NFPA 54.

4.2 Distribution System Piping

4.2.1 Equivalent Lengths of Piping. To the straight lengths of pipe along a pipeline route, add equivalent lengths for valves and fittings as indicated in Table 7.

4.2.2 Sizing of Distribution Piping. Size distribution piping as follows:

4.2.2.1 Minimum Pipe Size. Use minimum of 2-inch (51 mm) pipe which requires extra strong piping for direct buried piping with threaded end connections sized for piping in shallow trench system with all joints welded. Smaller pipe sizes and threaded joints are allowable in valve manholes.

4.2.2.2 Steam Piping. The project designer shall specify the design temperatures and pressures. The approved systems are suitable for temperatures to 450 degrees F (232 degrees C). If higher temperature systems are required, review manufacturers' approved brochures to determine the exceptions to the brochures to be made in the project specification relative to pipe material, pipe expansion, and valve classification. Design considerations are as follows:

MIL-HDBK-1003/8A

Table 7
 Representative Equivalent Length in Pipe/Diameter Ratio (L/D) for Various Valves and Fittings 1/

ITEM	DESCRIPTION OF PRODUCT	EQUIVALENT LENGTH IN PIPE LENGTH/DIAMETER
Valves:		
Conventional globe	With no obstruction in flat, bevel or plug type seat.	Fully open 340
	With wing or pin guided disc.	Fully open 450
Y-pattern globe	With stem 60 degrees from run of pipe line.	Fully open 175
	With stem 45 degrees from run of pipe line.	Fully open 145
Conventional angle	With no obstruction in flat, bevel or plug type seat.	Fully open 145
	With wing or pin guided disc.	Fully open 200
Conventional wedge, disc, plug or gate.		Fully open 13
		Three-quarters open 35
		One-half open 160
Pulp stock gate		One-quarter open 900
		Fully open 17
		Three-quarters open 50
		One-half open 260
		One-quarter open 1,200
		Fully open 3 2/3
Conduit pipe line gate		Fully open 20
Butterfly 6-inch and larger		0.5 2/3 - Fully open 135
Conventional swing check		0.5 2/3 - Fully open 50
Cleanway swing check		2.0 2/3 - Fully open
Globe lift check or stop-check		2.0 2/3 - Fully open
Angle lift check or stop-check		2.0 2/3 - Fully open
Foot valves	With strainer and poppet lift-type disc.	0.3 2/3 - Fully open 420
	With strainer and leather-hinged disc.	0.4 2/3 - Fully open 75
In-line ball check	2.5 vertical and 0.25 horizontal	3 - fully open 150
Straight through cocks	Rectangular plug port area equal to 100% of pipe area.	Fully open 18
Three-way cocks	Rectangular plug port area equal to 80% of pipe area (fully open).	Flow straight through 44
		Flow through branch 140
Fittings:		
90 degrees standard elbow		30
45 degrees standard elbow		16
90 degrees long radius elbow		20
90 degrees street elbow		50
45 degrees street elbow		26
Square corner elbow		57
Standard tee	With flow through run.	20
	With flow through branch.	60
Close pattern return bend		50

1/ Legitimate for all flow conditions except in laminar flow range where Reynolds number is less than 1000.

2/ Exact equivalent length is equal to the length between flange faces of welding ends.

3/ Minimum calculated pressure drop in psi across valve to provide sufficient flow to lift disc fully.

Note: For additional data refer to DM-3.05.

MIL-HDBK-1003/8A

a) Steam Flow Charts. For pressures of 30 psig (206.7 kPa), 50 psig (344.5 kPa), 100 psig (689.4 kPa), and 150 psig (1033.5 kPa), see Figures 3 through 6. These charts show weight-rate pressure drop and velocities of saturated steam in Schedule 40 steel pipe. By selecting all pipe sizes on an optimum pressure drop, the total pressure drop of a pipeline may be estimated from an equivalent length, irrespective of pipe size. The charts are based on the rational flow formula (Darcy) shown below. For higher pressures, refer to Piping Handbook, by Crocker and King.

b) Rational Flow Charts. The simplified rational flow formula (Darcy) is used for compressible fluids for all pressures:

$$\text{EQUATION: } P_{r100} = W^2 (0.000336f) v/d^5 = C_{r1} \times C_{r2} \times v \quad (2)$$

Where:

P_{r100} = pressure drop per 100 feet of equivalent length of pipe (psi)

C_{r1} = $W^2 / 10^9$ (for values, see Figure 7)

C_{r2} = $336000f/d^5$ (for values, refer to Table 8)

W = rate of flow, pounds per hour (pph) (0.454 Kg/h)

f = friction factor

d = inside diameter of pipe (in)

v = specific volume of fluid (ft³ per lb) at average pressure

c) Velocities. (Refer to Table 9.)

$$\text{EQUATION: } V = \frac{3.06W}{d^2} \quad (3)$$

Where:

V = velocity of flow (fpm)

R = density (pcf)

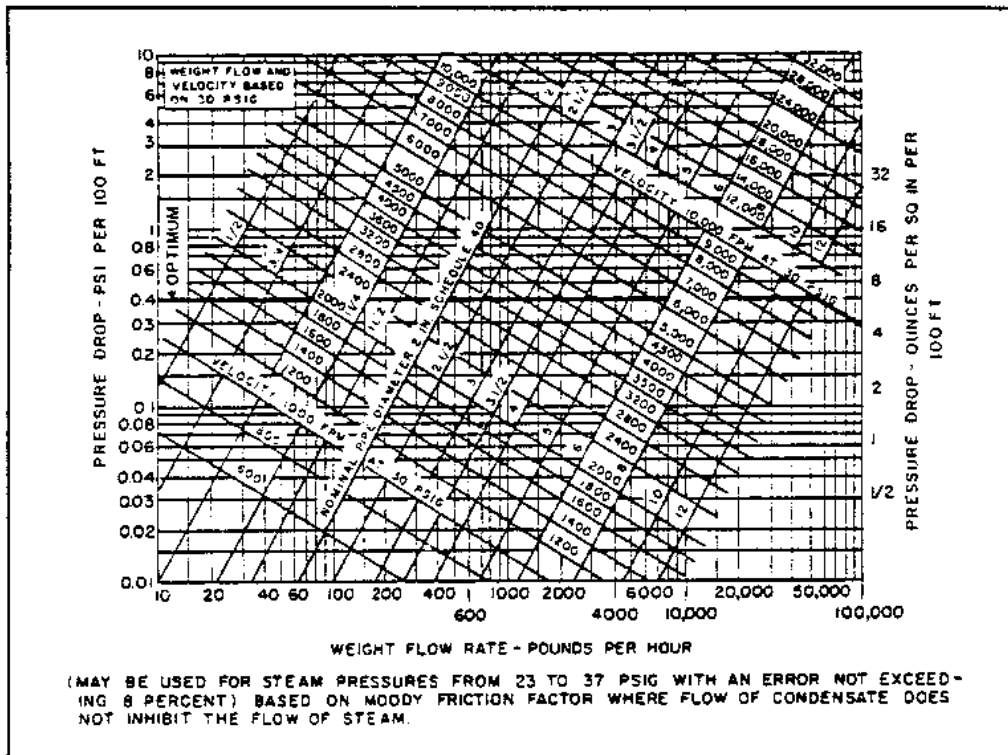

Figure 3

Chart for Weight-Flow Rate and Velocity of Steam (30 psig) (206.7 kPa)

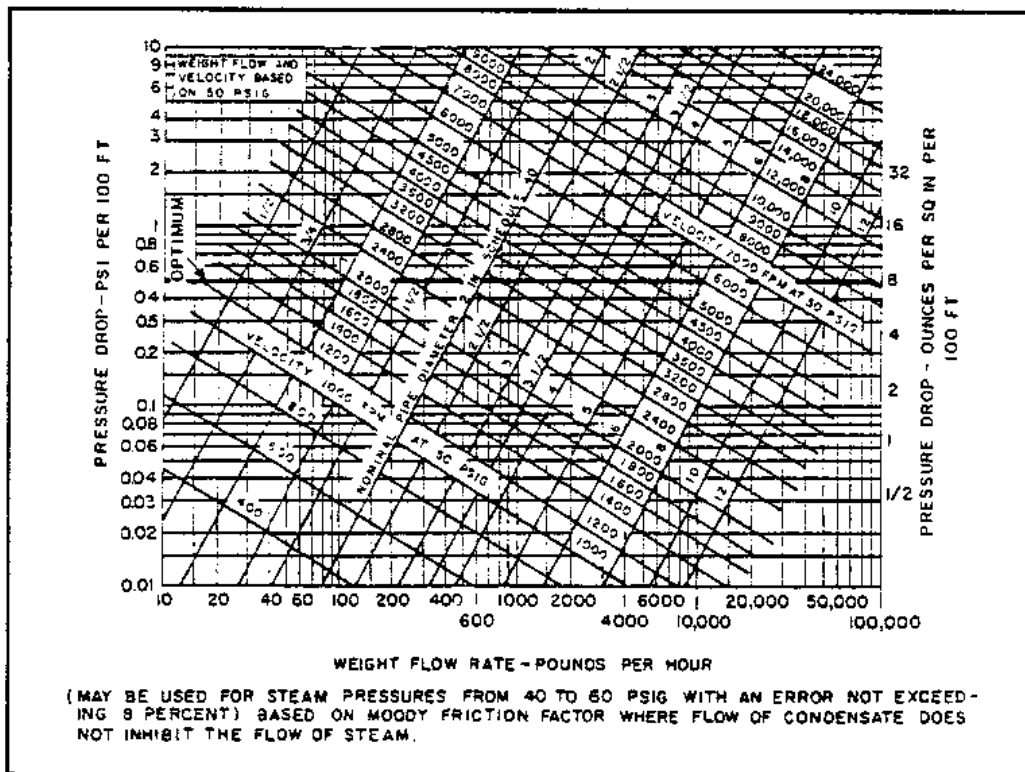

Figure 4

Chart for Weight-Flow Rate and Velocity of Steam (50 psig) (344.5 kPa)

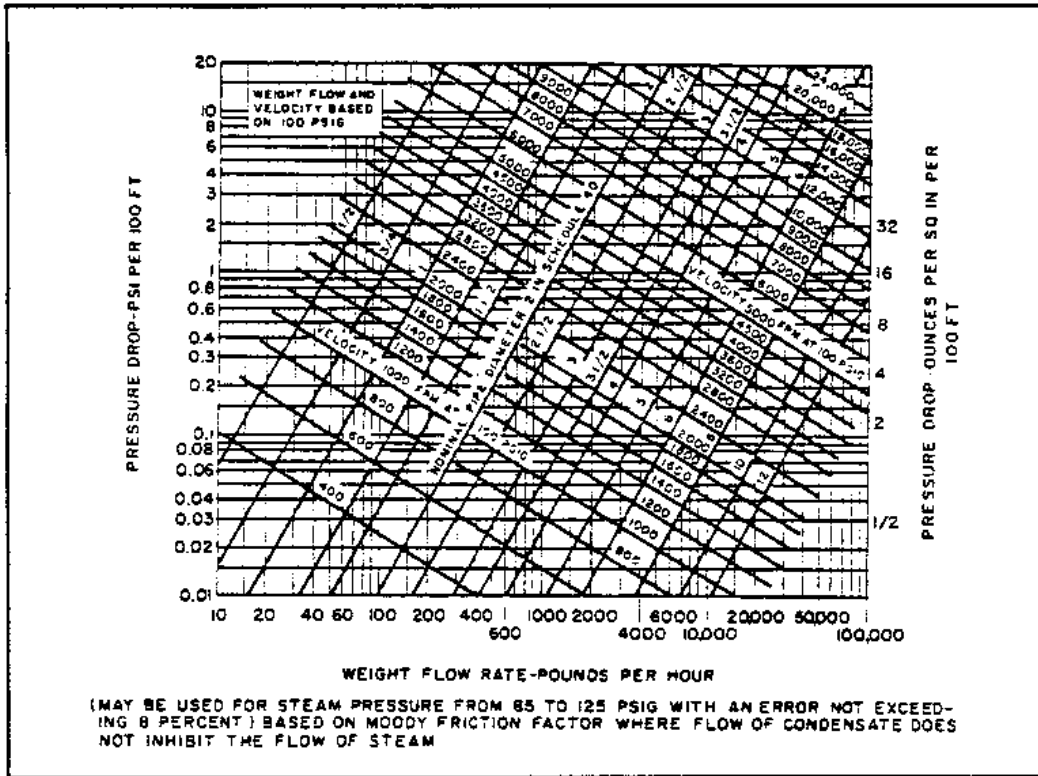

Figure 5
Chart for Weight-Flow Rate and Velocity of Steam (100 psig) (689.4 kPa)

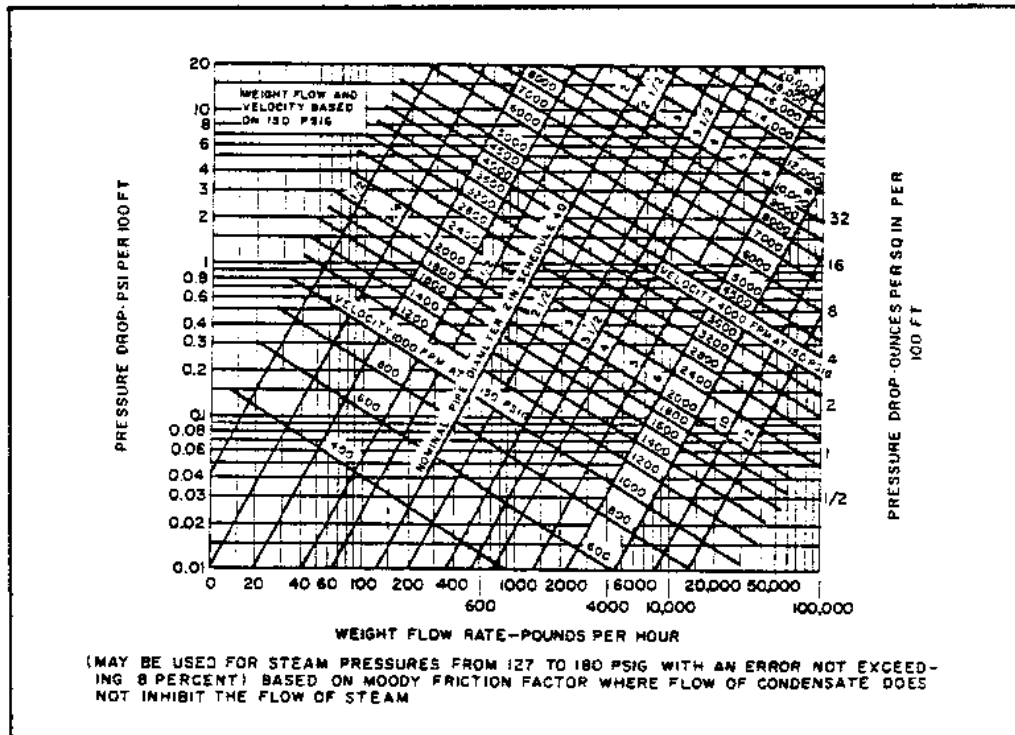

Figure 6
Chart for Weight-Flow Rate and Velocity of Steam (150 psig) (1033.5 kPa)

MIL-HDBK-1003/8A

MIL-HDBK-1003/8A

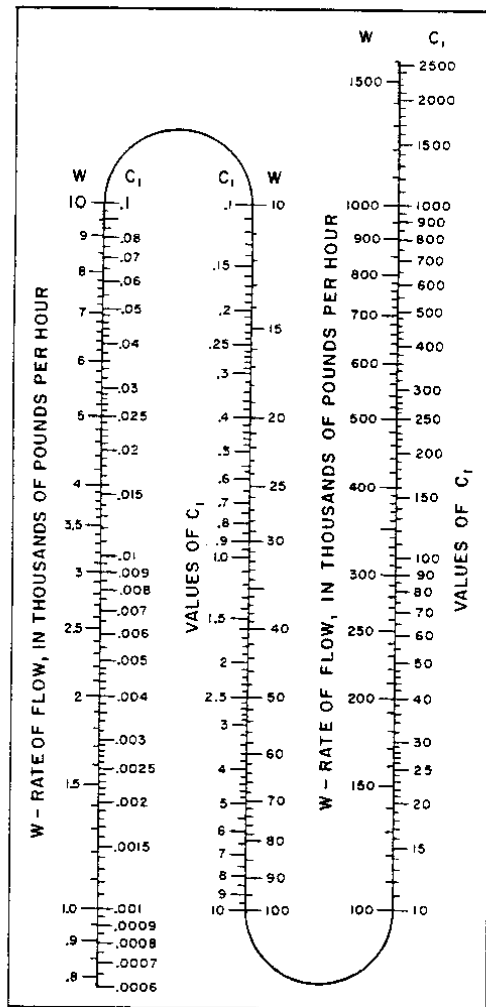

Figure 7
Values of C_1 , Flow Factor in Equation 1

MIL-HDBK-1003/8A

MIL-HDBK-1003/8A

Table 8 (Continued)
Values of C_2 , Flow Factor in Equation (1)

NOMINAL PIPE SIZE	SCHEDULE	VALUE OF C_2	NOMINAL PIPE SIZE	SCHEDULE	VALUE OF C_2	
12	20	0.015 7	20	10	0.001 41	
	30	0.016 8		20 S	0.001 50	
	40	S		0.017 5	30 X	0.001 61
		X		0.018 0	40	0.001 69
	60	0.019 5		60	0.001 91	
	100	0.020 6		80	0.023 1	
	140	0.026 7		120	0.031 0	
	0.035 0	160	0.042 3			
14	10	0.009 49	24	10	0.000 534	
	20	0.009 96		20 S	0.000 565	
	30	0.010 46		30 X	0.000 597	
	40	0.010 99			0.000 614	
	60	X		0.011 55	40	0.000 651
				0.012 44	60	0.000 741
	80	0.014 16		80	0.000 835	
	100	0.016 57		100	0.000 972	
	120	0.018 98		120	0.001 119	
	140	0.021 8		140	0.001 274	
	160	0.025 2		160	0.001 478	
16	10	0.004 63				
	20	0.004 21				
	30	0.005 04				
	40	0.005 49				
	60	0.006 12				
	80	0.007 00				
	100	0.008 04				
	120	0.009 26				
	140	0.010 99				
160	0.012 44					
18	10	0.002 47				
	20	0.002 56				
	30	S	0.002 66			
		X	0.002 76			
	40	0.002 87				
	60	0.002 98				
	80	0.003 35				
	100	0.003 76				
	120	0.004 35				
	140	0.005 04				
	160	0.005 73				
	0.006 69					

NOTE: The letters s, x, and xx in the columns of Schedule No. indicate Standard, Extra Strong, and Double Extra Strong pipe respectively.

MIL-HDBK-1003/8A

Table 9
Reasonable Velocities for Flow of Steam in Pipes

CONDITION OF STEAM	PRESSURE (psig)	SERVICE	REASONABLE VELOCITY [1] (fpm)
Saturated	Vacuum	Turbine exhaust	Up to 18,000
	0 to 25	Heating	4,000 to 6,000
	25 and up	Steam distribution	6,000 to 10,000
	125 and up	Underground steam distribution	Up to 20,000
Superheated	200 and up	Boiler and turbine leads	7,000 to 20,000

[1] Velocities should be below those which would produce excessive noise or erosion.

d) Steam Distribution Pressures. Steam pressure is governed by the highest pressure needed by the equipment served at the most remote location as well as by an economic analysis of the feasible systems, including pressure considerations. The advantages of a low-pressure system (under 15 psig) (103.4 kPa) are low distribution loss, lower losses and less trouble from leakage, traps, and venting, simplified pressure reduction at buildings, standard steel fittings, and low maintenance. The advantages of high-pressure distribution, over 50 psig (344.5 kPa), are smaller pipe sizes, availability of steam for purposes other than for heating, and more flexibility in velocities and pressure drops.

e) Selection of Valve Types. Install double-ported, pilot-operated valves for large capacities, especially for inlet pressures above 125 psig (861.3 kPa). Double-ported valves will not shut off completely on no-load demand; therefore, single-seated valves must be used for such services. Do not install reducing valves on the basis of pipe sizes, because oversized valves do not give satisfactory service. Select valves to operate generally fully open, with ratings and reduction ratios as recommended by the manufacturer. Install a strainer and condensate drain ahead of the pressure-reducing valve. Because the volume of steam increases rapidly as the pressure is reduced, a reducing valve with increased outlet or expanding nozzle is required when the reduction ratio is more than 15 to 1. Provide cutout valves to isolate the pressure reducing valve to permit maintenance. Where the resulting superheated steam temperature is objectionable to the process on the low pressure side or the temperature-use limit of the equipment has been exceeded, a desuperheater must be used to lower the steam temperature to that for saturation. Provide a manual bypass for emergency operation when the

MIL-HDBK-1003/8A
Change 2, 30 December 1991

pressure reducing valve is out of service. Provide a pressure gauge on the low pressure side. Where steam requirements are relatively large, above approximately 3,000 pounds/hour (1364 kg/hr), and subject to seasonal variation, install two reducing valves in parallel, sized to pass 70 percent and 30 percent of maximum flow. During mild spring and fall weather, set the large valve at a slightly reduced pressure so that it will remain closed as long as the smaller valve can supply the demand. During the remainder of the heating season reverse the valve settings to keep the smaller one closed except when the larger one is unable to supply the demand.

f) Safety Valves. Provide one or more relief or safety valves on the low pressure side of each reducing valve in case the piping and/or equipment on the low pressure side do not meet the requirements of the full initial pressure. The combined discharge capacity of the relief valves shall be such that the pressure rating of the lower pressure piping and equipment will not be exceeded. For special conditions refer to ASME B31.1 and ASHRAE Handbooks - Systems and Applications.

g) Takeoffs from Mains. Takeoffs from mains to buildings must be at the top of mains and located at fixed points of the mains, at or near anchor points. When a branch is short, valves at each takeoff are unnecessary. Takeoffs shall have valves when the branch is of considerable length or where several buildings are served. A 45 degree takeoff is preferred; 90 degree takeoffs are acceptable. Branch line slope of 1/2 inch (12.6 mm) should be used for lines less than 10 feet (3.05 m) in length and should be 1/2 inch per 10 feet (3.05 m) on branch lines longer than 10 feet.

4.2.2.3 Condensate Returns. Condensate returns are preferred if owning and operating costs of such a system are less than that of using and treating raw water for makeup. Factors favoring condensate return are: high area concentration of steam usage; restriction on condensate disposal; high raw water treatment costs; water treatment space unavailable; high cost of raw water; and high cost of fuel for feedwater heating. Design considerations are as follows:

a) Return Piping. Size condensate trap piping to conform with 30 to 150 psig (206.7 to 1033.5 kPa) steam piping in accordance with Tables 10 and 11 and interpolate these for other pressures.

b) Discharge Piping. Size discharge piping from condensate and heating pumps in accordance with pump capacities, which may be between one to three times the capacity of the steam system branch which they serve, depending on whether continuously or intermittently operated.

MIL-HDBK-1003/8A
Change 2, 30 December 1991

Table 10
Return Pipe Capacities for 30 psig (206.7 kPa) Steam Systems (a)
(Capacity Expressed in lbs/hr)

DROP IN PRESSURE (psi PER 100 ft IN LENGTH)					
PIPE SIZE (in.)	1/8	1/4	1/2	3/4	1
3/4	115	170	245	308	365
1	230	340	490	615	730
1-1/4	485	710	1,025	1,290	1,530
1-1/2	790	1,160	1,670	2,100	2,500
2	1,580	2,360	3,400	4,300	5,050
2-1/2	2,650	3,900	5,600	7,100	8,400
3	4,850	7,100	10,300	12,900	15,300
3-1/2	7,200	10,600	15,300	19,200	22,800
4	10,200	15,000	21,600	27,000	32,300
5	19,000	27,800	40,300	55,500	60,000
6	31,000	45,500	65,500	83,000	98,000

(a) Based on 0-4 psig maximum return pressure.

Table 11
Return Pipe Capacities for 150 psig (1033.5 kPa) Steam Systems (a)
(Capacity Expressed in lbs/hr)

DROP IN PRESSURE (psi PER 100 ft IN LENGTH)						
PIPE SIZE (in.)	1/8	1/4	1/2	3/4	1	2
3/4	156	232	360	465	560	890
1	313	462	690	910	1,120	1,780
1-1/4	650	960	1,500	1,950	2,330	3,700
1-1/2	1,070	1,580	2,460	3,160	3,800	6,100
2	2,160	3,300	4,950	6,400	7,700	12,300
2-1/2	3,600	5,350	8,200	10,700	12,800	20,400
3	6,500	9,600	15,000	19,500	23,300	37,200
3-1/2	9,600	14,400	22,300	28,700	34,500	55,000
4	13,700	20,500	31,600	40,500	49,200	78,500
5	25,600	38,100	58,500	76,000	91,500	146,000
6	42,000	62,500	96,000	125,000	150,000	238,000

(a) Based on 1-20 psig maximum return pressure.

MIL-HDBK-1003/8A

c) Common Pump Discharge Mains. Size common pump discharge mains to serve the sum of their capacities. Use the Hydraulic Institute (HI) Pipe Friction Manual for steel pump discharge pipe sizing of new clean steel pipe, 6 feet per second (fps) (1.83 m/s) maximum velocity, and a correction factor of 1.85 to provide for increased pressure drops when the pipe becomes dirty and rough with age. Friction plus static heads shall not exceed the pump characteristics of standard pump and receiver units.

4.2.2.4 High Temperature Water (HTW) Piping. High temperature water piping is as follows:

a) Sizing Piping. Use pipe friction charts in ASHRAE 1985 Handbook Fundamentals. These charts are based on the rational flow formula using clean pipe. A reasonable average velocity is approximately 5 fps (1.53 m/s). The minimum allowable velocity is 2 fps (0.61 m/s).

b) Venting and Draining. For methods of venting high points of distribution lines, refer to DM-3.03, Heating, Ventilating, Air Conditioning and Dehumidifying Systems. Piping must have drainage means at low points.

4.2.2.5 Chilled Water Piping. Use the standards of the Hydraulic Institute Pipe Friction Manual for sizing new clean pipe, unless water is renewed annually, in which case a correction factor of 1.41 for pressure drop is also to be used. For recommended velocities, refer to DM-3.03.

4.2.2.6 Condenser Water Piping. Use the standards of the Hydraulic Institute Pipe Friction Manual for pipe sizing, multiplying the pressure drop by a factor of 1.85 to correct for the increase of pipe roughness with age. For recommended velocities, refer to DM-3.03. No correction factor is required for RTRP pipe.

4.2.2.7 Natural Gas Piping. Apply criteria in DM-3.01, Plumbing Systems, for sizing pipe inside buildings. Use Figure 8 for low volume flow rates and Figure 9 for high volume flow rates in sizing distribution piping. Using these figures will simplify design of piping by indicating required diameter, maximum rate of flow, permissible pressure drop, initial pressure, or final pressure when the rest of these values are known. These charts are based on the Weymouth formula for rate of flow in cubic feet of gas per hour. (The chart is based upon the following conditions: gas at 60 degrees F (15.5 degrees C) and specific gravity of 0.60, with air = 1.0.). Exterior distribution piping usually stops 5 feet (1.53 m) outside of buildings.

4.2.2.8 Compressed Air. For criteria on distribution piping, refer to DM-3.5, Compressed Air and Vacuum Systems.

4.2.3 Piping Specifications and Codes. Piping specifications and codes are as follows:

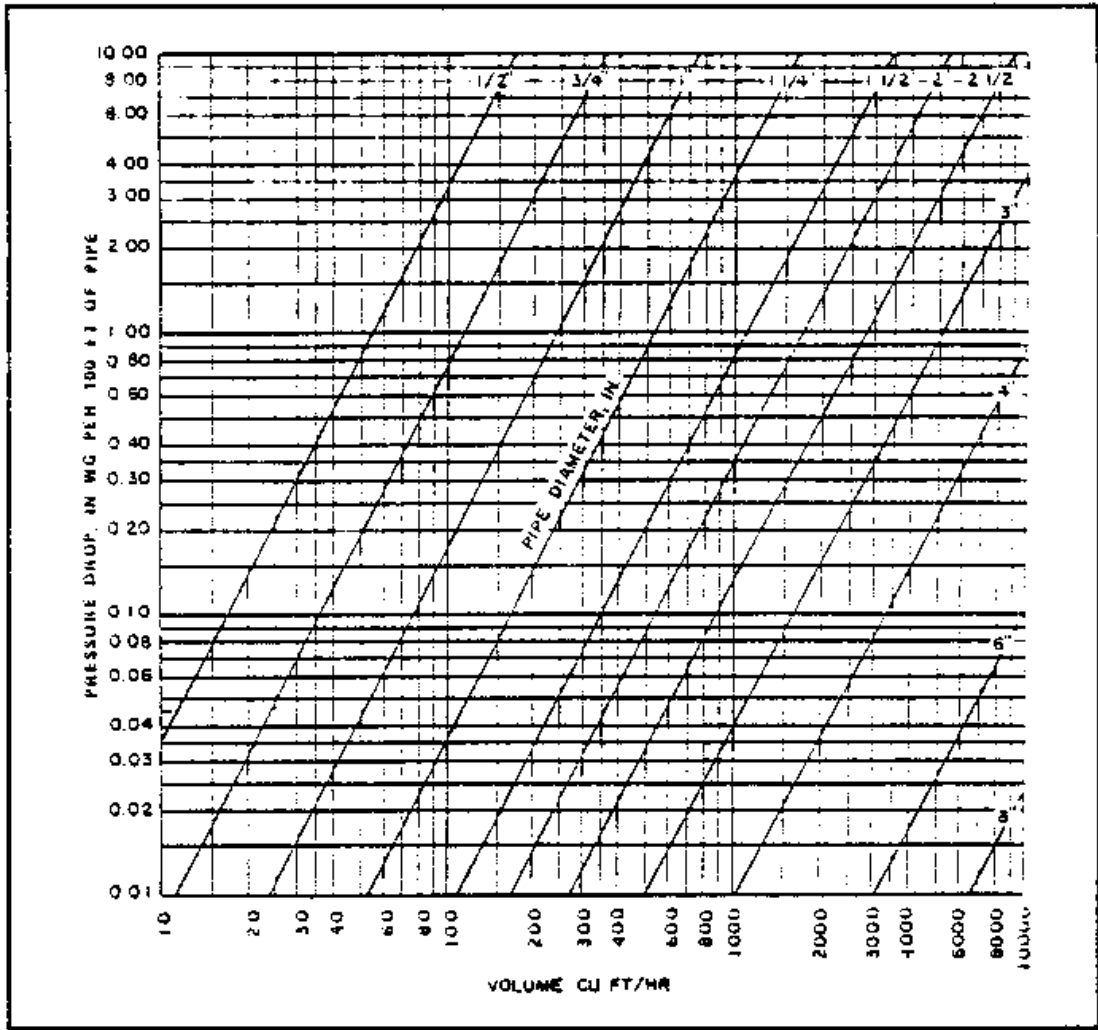

Figure 8
 Low Volume Flow Rate Natural Gas Chart (10 to 10,000 ft³/hr)
 (.283 to 283 m³/hr)

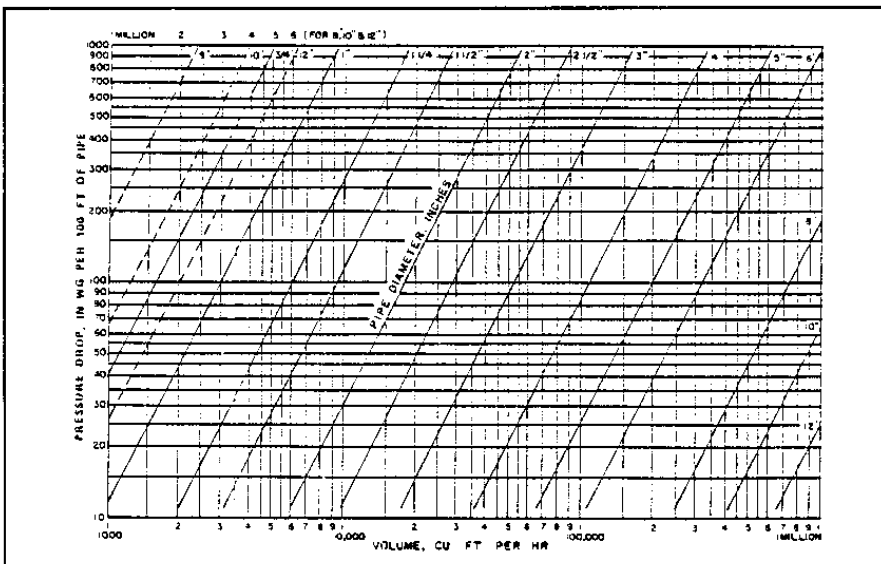

Figure 9
 High Volume Flow Rate Natural Gas Chart (1,000 to 1 million ft³ hr)
 (28.3 to 28,300 m³/hr)

MIL-HDBK-1003/8A
Change 2, 30 December 1991

4.2.3.1 Steam Supply and Condensate Return. Piping shall conform to ASME B31.1, except for underground prefabricated or pre-engineered type systems, in which case the entire system shall conform to NFGS-02694.

a) If a separate pump condensate return system is used, it shall conform to NFGS-02697.

b) For condensate provided as a part of an underground prefabricated, pre-engineered system, include Mil. Spec MIL-P-28584 plastic condensate piping in the specification as a Contractor's option for sites classified B, C, or D. Plastic piping is optional but encouraged for sites classified A. The Contracting Officer shall give specific approval for plastic condensate piping in Class A systems. Take particular care that the failure of high pressure steam drip traps shall not discharge high temperatures and pressures into the plastic condensate piping.

4.2.3.2 High Temperature Water, Medium Temperature Water, and Low Temperature Hot Water. Piping specifications and codes are as follows, except for underground prefabricated or pre-engineered types, in which case the entire system shall conform to NFGS-02694.

a) Piping. HTW metallic piping (450 degrees F maximum) (232 degrees C) and medium temperature water metallic piping shall conform to ASME B31.1.

b) Joints. Welded joints are preferred. Threaded joints are not permitted. Hold flanged joints to a minimum and use ferrous alloy gaskets in such joints. Avoid the use of copper and brass pipe.

c) Valves. All valves shall have cast steel bodies with stainless steel trim (no bronze trim). All valves shall be capable of being repacked under operational pressures. Use gate valves only as shutoff or isolation valves.

4.2.3.3 Natural Gas and Compressed Air. Piping shall conform to ASME B31.1 and B31.8 including guidance for abandoning existing gas lines. Note that ASME B31.8 requires that abandoned gas lines be physically disconnected from gas sources and purged prior to sealing. Shutoff valves are not an acceptable means of disconnect. Cathodic protection systems on lines to be abandoned should be evaluated for modifications required to ensure continuity of the systems after abandoned lines are disconnected or removed. Provide excess-flow (earthquake) shutoff valves in gas supply piping outside of each building served in earthquake zones 3 and 4. In addition, provide flexible connections. Gas piping and appurtenances from point of connection with existing system to a point approximately 5 feet (1.53 m) from the building shall conform to NFGS-02685.

4.2.3.4 Chilled and Condenser Water. Use Schedule 40 steel pipe in 10-inch (254 mm) size and smaller, and use 1/2-inch (12.5 mm) wall thickness steel

MIL-HDBK-1003/8A
Change 2, 30 December 1991

pipe for 12-inch (305 mm) size and larger. RTRP pipe and PVC pipe are also acceptable. RTRP pipe and PVC pipe are available in 2 through 12-inch (51 through 305-mm) pipe sizes.

4.2.4 Thermal Expansion of Steel and Copper Pipe. Pipe expands with temperature increases (such as between installation and operating temperatures) as indicated in Table 12. Make provisions for the control of expansion in any piping system where thermal expansion is a factor. Wherever possible, provide for expansion of pipes by changes in direction of pipe runs.

4.2.4.1 Branch Lines. Where practicable, design branch line piping to provide for expansion inside buildings. Expansion control of branch lines should be designed so as to have no effect on mains.

4.2.4.2 Expansion Bends. Bends are to be factory fabricated except for RTRP pipe.

a) Loop Sections. Loops may be furnished in sections to facilitate delivery and handling.

b) Anchors. A reasonable distance between anchors for expansion loops is 200 feet (61 mm) for 125 psig (861.3 kPa) steam system. Expansion is usually kept at about 6 inches (150 mm) between anchors.

c) Cold Springing. Cold springing may be used in installations but no design stress relief is allowed for it. For credit permitted in thrust and moments, refer to ANSI B31.1.

4.2.4.3 Expansion Joints. Install expansion joints only where space restrictions prevent the use of other means. When necessary to use, expansion joints shall be in an accessible location and shall be one of the following types:

a) Mechanical Slip Joint. An externally guided joint designed for repacking under operating pressures. Hold maximum traverse of piping in expansion joints under 8 inches (203 mm).

b) Bellows Type Joint. Use these joints on steel pipe for thermal expansion with stainless steel bellows, guided and installed according to manufacturer's instructions. Make bellows or corrugations for absorbing vibrations or mechanical movements at ambient temperatures of copper or other materials suitable for the job conditions. A maximum travel of 4 inches (102 mm) is allowed for this type. RTRP expansion joints may be polytetrafluoroethylene bellows type.

c) Flexible Ball Joints. Install these joints according to manufacturer's instructions.

MIL-HDBK-1003/8A
Change 2, 30 December 1991

4.2.4.4 Flexibility Analysis. Refer to ASME B31.1 for expansion and flexibility criteria and allowable stresses and reactions.

MIL-HDBK-1003/8A

Table 12
Pipe Expansion in Inches Per 100 Feet (30.5 m) of Length
for Temperature Shown

CHANGE IN TEMPERATURE (Degrees F)	MATERIAL		CHANGE IN TEMPERATURE (Degrees F)	MATERIAL	
	STEEL	COPPER		STEEL	COPPER
0	0	0	390	3.156	4.532
10	0.075	0.111	400	3.245	4.653
20	0.149	0.222	410	3.334	4.777
30	0.224	0.333	420	3.423	4.899
40	0.299	0.444	430	3.513	5.023
50	0.374	0.556	440	3.603	5.145
60	0.449	0.668	450	3.695	5.269
70	0.525	0.780	460	3.785	5.394
80	0.601	0.893	470	3.874	5.519
90	0.678	1.006	480	3.962	5.643
100	0.755	1.119	490	4.055	5.767
110	0.831	1.233	500	4.151	5.892
120	0.909	1.346	520	4.342	6.144
130	0.987	1.460	540	4.525	6.396
140	1.066	1.575	560	4.715	6.650
150	1.145	1.690	580	4.903	6.905
160	1.224	1.805	600	5.096	7.160
170	1.304	1.919	620	5.291	7.417
180	1.384	2.035	640	5.486	7.677
190	1.464	2.152	660	5.583	7.938
200	1.545	2.268	680	5.882	8.197
210	1.626	2.384	700	6.083	8.460
220	1.708	2.501	720	6.284	8.722
230	1.791	2.618	740	6.488	8.988
240	1.872	2.736	760	6.692	9.252
250	1.955	2.854	780	6.899	9.519
260	2.038	2.971	800	7.102	9.783
270	2.132	3.089	820	7.318	10.056
280	2.207	3.208	840	7.529	10.327
290	2.291	3.327	860	7.741	10.598
300	2.376	3.446	880	7.956	10.872
310	2.460	3.565	900	8.172	11.144
320	2.547	3.685	920	8.389	11.420
330	2.632	3.805	940	8.608	11.696
340	2.718	3.926	960	8.830	11.973
350	2.805	4.050	980	9.052	12.253
360	2.892	4.167	1,000	9.275	12.532
370	2.980	4.289	1,000	10.042	13.950
380	3.069	4.411	1,200	11.598	15.397

MIL-HDBK-1003/8A

4.2.4.5 Stress Analysis. For methods of analyzing stresses in piping systems, use piping handbooks and publications of pipe and pipe fitting manufactures. These manufactures also supply calculation forms and charts. Keep calculated pipe stresses under those allowed by ANSI B31.1.

4.2.5 Insulation of Piping Systems. Use NFGS-02694 for insulation design for underground heat distribution piping. Use NFGS-02696 for above grade steam, condensate, HTW, MTW, and LTW. Use applicable sections of NFGS-15250 for other systems.

4.2.5.1 Insulation Thickness. Insulation thicknesses indicated in NFGS-02696 and in NFGS-15250 are suitable for most geographic locations. However, in locations where extreme annual temperatures occur, the project designer should evaluate different thicknesses of insulation. Make final selection based on an economic analysis in accordance with para. 2.3.5.

4.2.5.2 Jackets. Design insulation jackets in waterfront or other locations subject to flooding to drain; they shall not be watertight.

4.2.6 Drainage Provisions. Drainage provisions must conform to requirements listed below.

4.2.6.1 Pitch. The surrounding terrain and piping application both affect the pitch of piping as indicated below.

a) Horizontal Piping. Pitch horizontal steam piping down at a minimum of 2-1/2 inches (64 mm) per 100 feet (30.5 m) of length in the direction of steam flow.

b) Underground Piping. Pitch horizontal piping down towards drain points (unless otherwise noted) a minimum of 2-1/2 inches (64 mm) in 100 feet (30.5 m). Where the ground surface slopes in the opposite direction to steam piping, step up underground piping in vertical risers at drip points in manholes, and pitch them down to the next drip point. Use this method also for all very long horizontal runs, above- or belowground, to keep piping within a reasonable range of elevations with reference to the ground surface.

c) Counter-Flow Conditions. Where counter-flow of condensate within the steam pipe may occur in a portion of a pipeline because the stepped construction cannot be built, or because of steam flow reversal in a loop system, pitch that portion up in the direction of steam flow a minimum of 6 inches (152 mm) per 100 feet (30.5 m) and increase pipe diameter by one standard pipe size.

d) Compressed Air and Natural Gas Lines. Pitch compressed air and gas piping as for steam piping.

MIL-HDBK-1003/8A
Change 2, 30 December 1991

e) Pumped Water Pipe. Pitch pumped water pipes (condensate, HTW, MTW, LTW, CHW, or condenser water) up or down in direction of flow at a minimum slope of 2-1/2 inches (64 mm) per 100-foot (30.5 m) length. Place drain valves at all low points and vents at high points.

4.2.6.2 Drips and Vents. Provide drips and vents as follows:

a) Drip Legs. Provide drip legs to collect condensate from steam piping and compressed air piping for removal by automatic moisture traps, or by manual drain valves for compressed air piping when practicable. Locate drip legs at low points, at the bottom of all risers, and at intervals of approximately 200 to 300 feet (61 to 91.5 m) for horizontally pitched pipe where a trap is accessible, and not over 500 feet (152.5 m) for buried underground pipe systems. On gas piping, drip legs are not usually required where dry gas is provided. Where there is moisture in the gas, provide drip legs and sediment traps in accordance with NFPA 54. Automatic traps are not utilized.

b) Water Piping. Vent piping, especially high-temperature water piping, at distribution piping high points.

c) Fuel Gas Piping. Provide capped dirt traps in vertical risers upstream of gas-burning devices.

4.2.6.3 Condensate Systems. Condensate systems are as follows:

a) Furnish a complete system of drip traps and piping to drain all steam piping of condensate from drip legs. Ensure drip piping to traps is the same weight and material as the drained piping.

b) Preferably, run a condensate line from a trap separately to a gravity condensate return main or to a nearby flash tank. (Refer to ASHRAE Handbooks - Systems and Applications for flash tank details and specific trap applications. Additionally, refer to Naval Civil Engineering Laboratory (NCEL) UG-0005, Steam Trap Users Guide.) However, a trap may be discharged through a check valve into the pumped condensate line if pressure in the trap discharge line exceeds the back pressure in the pumped condensate line during standby time of an intermittently operated pump. If the pumped condensate line is RTRP pipe, install a condensate cooling device, similar to that shown in Figure 10, to limit temperature of the condensate entering the line to less than 250 degrees F (121 degrees C).

c) Select traps using a safety load factor no greater than 2. The condensate load should be indicated on design drawings and may be determined for aboveground lines by using Table 13. The condensate load for underground distribution lines is determined from maximum heat loss as indicated by the design. With the tight safety load factor for sizing traps, an alternate

MIL-HDBK-1003/8A
Change 2, 30 December 1991

method of expelling gasses during warmup is required. To this end, all strainers should have blowdown valves which will also be used for controlled warmup.

Table 13
Condensate Loads from Aboveground Heat Distribution Piping
(Pounds Per Hour Per 100 Linear Feet)

STEAM PRESSURE (psig)	STEAM PIPE SIZE (INCHES, DIAMETER)					
	2	4	6	8	10	12
10	6	12	16	20	24	30
30	10	18	25	32	40	46
60	13	22	32	41	51	58
125	17	30	44	55	68	80
300	25	46	64	83	203	122
600	37	68	95	124	154	182

d) Pitch discharge piping down a minimum of 3 inches (76 mm) per 100 feet (30.5 m) to the collection tank. This applies where a condensate pump set or reliance upon a gravity return is used. An exception to this "rule-of-thumb" exists when there is sufficient pressure in a steam line to overcome its friction and static head, whether the line is level, or pitched up. Trap discharge line shall not be RTRP pipe nor shall the trap discharge connect to an RTRP pipe by direction connection. Install pipe through a condensate cooling device as depicted in Figure 10. This system provides a cooling tank and diffuser, plus a temperature relief valve to limit the temperature of condensate returned to a pumped RTRP condensate line to less than 250 degrees F (121 degrees C).

e) If it is not justifiable to return drips to a condensate system, they may be drained as waste to a sewer. If the temperature exceeds sewer limitations, condensate must be cooled in a sump or by other means. Disposal of condensate from steam systems along the waterfront or under piers warrants special consideration to be determined on a case-by-case basis.

4.2.7 Pipe Anchors. Ensure anchors comply with the following criteria:

4.2.7.1 Location. Locate anchors for non-pre-engineered/prefabricated systems at takeoffs from mains and other necessary points to contain pipeline expansion. If possible, locate anchors in buildings, piers, tunnels, and manholes with suitable access.

MIL-HDBK-1003/8A
Change 2, 30 December 1991

4.2.7.2 Specification. Design and locate anchors in accordance with ASME B31.1.

4.2.7.3 Strength. Design anchors to withstand expansion reactions. With expansion joints, consider the additional end reactions due to internal fluid pressure, and add end reactions due to spring rate of the joint.

4.2.7.4 Guying. Anchors for elevated aboveground systems shall consist of wire rope guys running from embedded concrete deadmen to pipe saddles welded to the pipe and secured to the vertical support(s). Guy in both directions. Guys may be located on the diagonal to serve also as sway bracing.

4.2.7.5 Embedding. In underground concrete tunnels, the ends of structural steel shapes anchoring a pipe may be embedded in the tunnel walls or floors.

4.2.8 Supports. Insure pipe supports conform to ASME B31.1.

4.2.8.1 Low Elevations. For aboveground systems at low elevations (defined as lower than 5 feet (1.53 m) above grade or the working surface), use and space concrete pedestals, steel frames, or treated wood frames as required depending on pipe sizes.

4.2.8.2 High Elevations. At higher elevations above ground, support pipelines on wood, steel pipe, H-section steel, reinforced concrete, prestressed concrete poles with crossarms, or steel frameworks fitted with rollers and insulation saddles. (See Figure 11.) Details of design will vary depending on site conditions.

4.2.8.3 Long Spans. When long spans are necessary, cable-suspension or catenary systems may be used.

4.2.8.4 Underground Conduits. Use approved types of manufacturers' standard designs supports for underground conduits.

4.2.8.5 In Trench. Suspend pipes either from the walls or the tops of the walls. Do not support piping from either the floor of the trench or from the removable top. The pipe hanger design must provide for adequate system expansion and contraction.

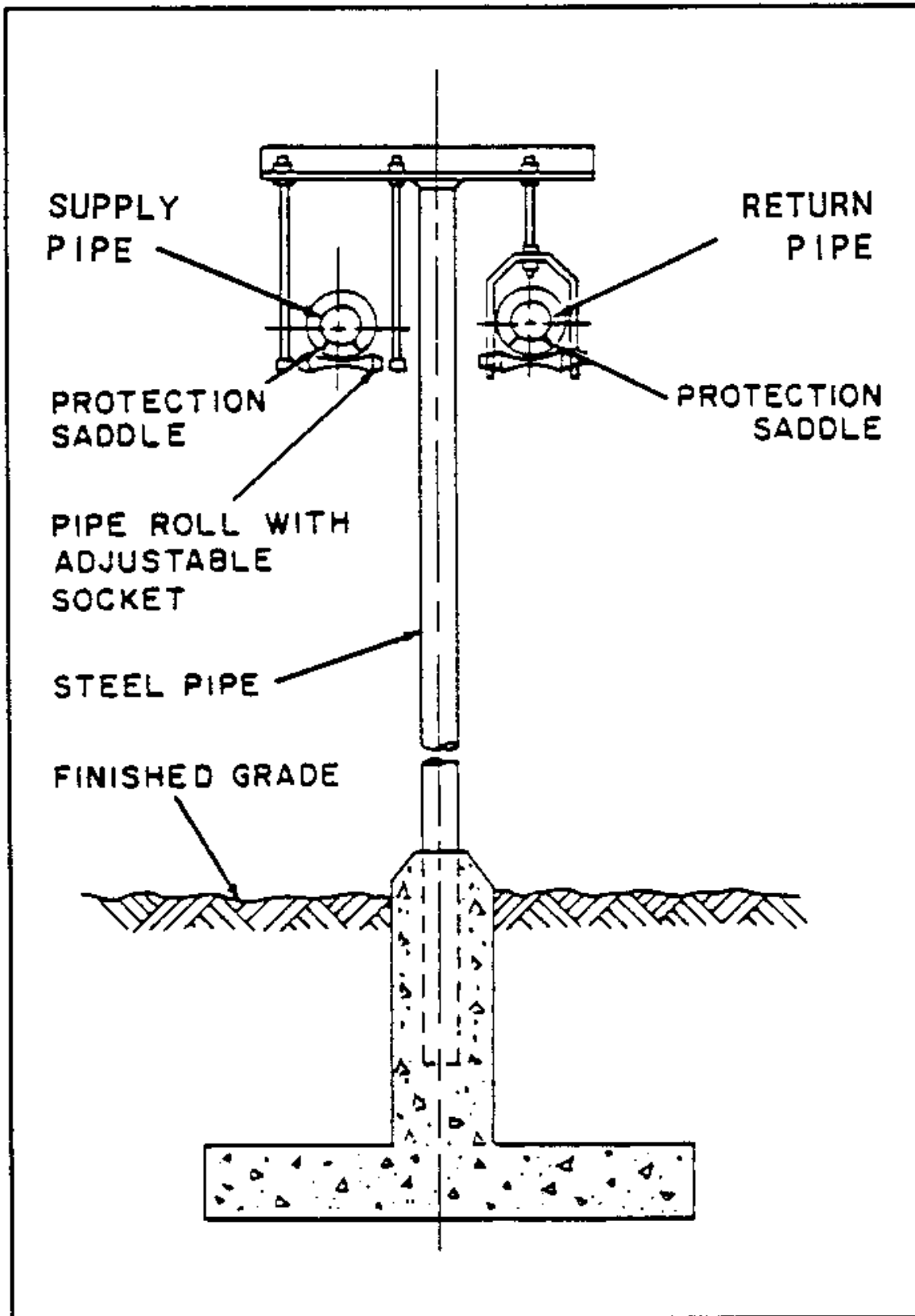

Figure 11
Typical Aboveground Pipe Supports

MIL-HDBK-1003/8A

4.2.9 Finish and Protection. All noninsulated ferrous parts of the piping, piping support system, or equipment will be hot-dipped galvanized or primed with red oxide primer and painted with epoxy paint.

4.3 Concrete Trench Design. The concrete shallow trench will consist of poured concrete sides and floor, with removable tops. Portions of the floor may be omitted at locations outlined previously under course grained soils with water table 2 feet (610 mm) or more below lowest point of water entry.

4.3.1 Depth of Trench. Ensure the depth of the concrete trench is sufficient to provide adequate protection to the piping system and, slope the floor of the trench to provide adequate internal drainage, but in all cases not less than 6 inches (150 mm) from the bottom surface of the suspended pipe insulation to the floor of the trench. Ensure there is a minimum of 3 inches (75 mm) between the surface of the pipe insulation and the adjoining trench walls and a minimum of 4 inches (100 mm) between surfaces of adjacent pipe insulation.

4.3.2 Drainage of Trench. Base the design on sound engineering practices which provide for drainage under all anticipated conditions. Consider the annual rainfall, water table, and other topographic conditions in the basis for the design. For those instances where natural drainage cannot be provided (storm water drainage system at least 2 feet (610 mm) below trench bottom at all times), provide a dual sump pump capability with failure annunciator.

4.3.3 Tops. The tops of the concrete trenches will be removable by use of a portable lifting device such as a forklift or backhoe, and can also be used for sidewalks, if practical. Earth must not cover the tops. Covers will be close tolerance fit with a maximum gap tolerance build up of 0.12 inch from all causes.

4.3.4 Details. Design the Concrete Shallow Trench Heat Distribution System and show on the contract drawings. Use Figures 12 through 23 as appropriate.

Provide the following information on the contract drawings for the concrete Shallow Trench System, as applicable: dimension on all runs of pipe; elevations of the pipe along the systems path; sizes of the pipe; location of all valves; location and details of all expansion loops, Z- and L-bends; location of pipe anchors; how changes in pipe direction are made; thickness of the insulation on the pipe; concrete trench details; final elevations of concrete trench; profile of trench showing all existing utilities; manhole dimensions; manhole cover details; how manhole is drained and vented where required; sump pump piping details; sump pump capacity; condensate pump capacity and details; include specific requirements for modification to existing; steam drip trap locations and capacity; steam pressure reducing valve capacity and details; and other pertinent information and details

MIL-HDBK-1003/8A

required to clearly show the intent of the Shallow Trench Heat Distribution System. Also indicate any obstructions in the path of the distribution system that the Contractor may have to work around.

4.3.5 Valve Manholes. Extend valve manholes at least 9 to 12 inches (175 to 305 mm) above finished grade to prevent seasonal runoff from entering except where trench will be a pedestrian walk, in which case the vault cover will be flush with the trench covers.

4.3.6 Inspection Ports. Where required, provide inspection ports at appropriate locations to enable the user to observe drains or expansion at loops or locations requiring frequent (monthly) observation.

4.3.7 Crossings. At all road and railroad type crossings, provide required slab thickness for railroad crossings and H-20 loading for street crossings. Review railroad track removal/replacement with respective authority and coordinate all activities. Road and rail crossing where maintenance of traffic is critical may be accomplished by jacking using an acceptable conduit/tunnel.

4.3.8 Precast Concrete Shallow Trench Options. In addition to or in combination with a poured-in-place concrete shallow trench system, a precast or prefabricated shallow trench system consisting of precast concrete covers, concrete trench, or supports may be specified. If the designer selects this option, he must include special details and specification requirements of the precast system and the transition between the poured-in-place and precast system.

4.4 Manholes

4.4.1 Drainage. Provide sump pumps in manholes. Units should discharge by buried piping to nearest storm sewer if possible. Where not economical to discharge to storm sewer, pumps are to discharge above grade to splashblocks. Plan discharge locations carefully so water will not be placed over tunnel tops, sidewalks, etc. Use sump pumps capable of passing 3/8-inch (12 mm) solid (sphere) minimum. Adjust float switches so the pumps start sequentially, reducing electrical line surge. Coordinate power requirements with electrical designer and provide tell-tale light above ground to indicate that power is available to sump pumps.

4.4.2 Waterproofing. If portions of manholes are installed below the water table, waterproof that portion below the water table.

4.4.3 Pipe Entry. Pipe entry, for buried pre-engineered systems piping, shall be in accordance with Figure 24.

MIL-HDBK-1003/8A

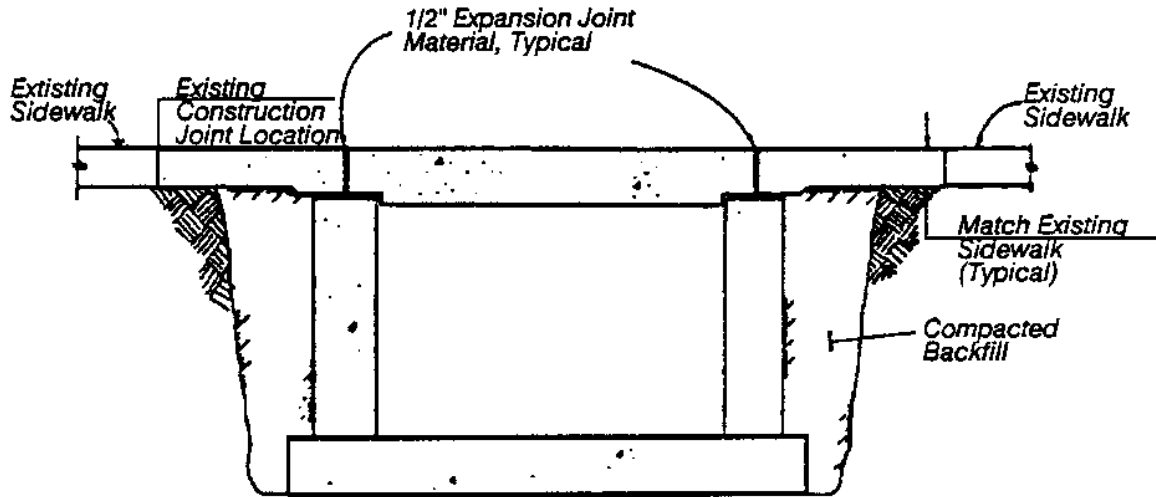

Sidewalk Transverse Cut Detail

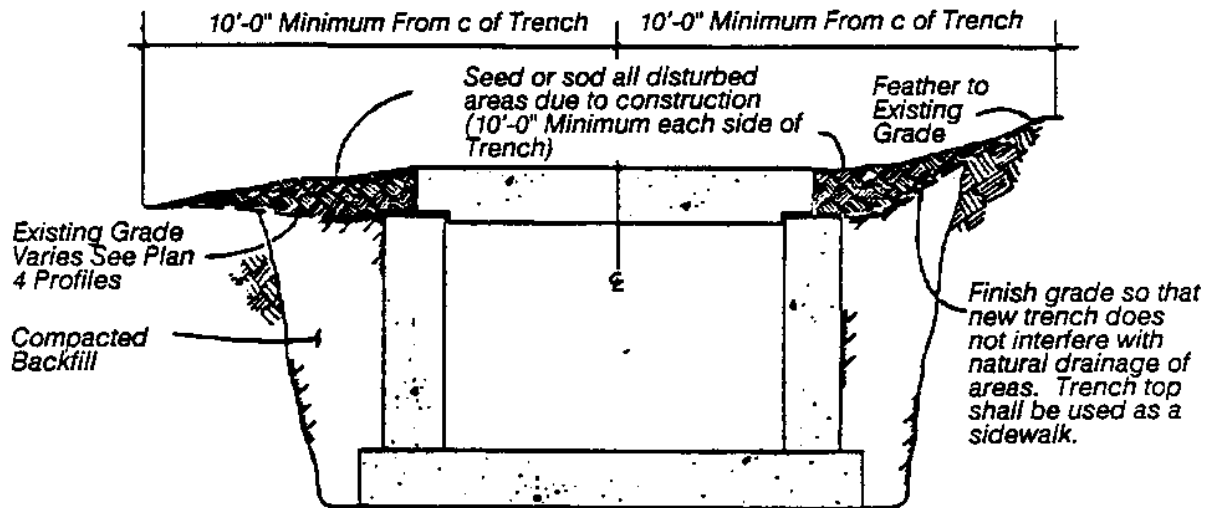

Note:
 Trench floors must be sloped to provide continuous drainage to sump pumps in manholes. All pockets found in trench floor shall be provided with a floor drain to the nearest manhole sump or the floor shall be sloped to provide gravity drainage.

TYPICAL TRENCH GRADING DETAIL

Figure 12
 Concrete Shallow Trench Heat Distribution System
 Detail 1

MIL-HDBK-1003/8A

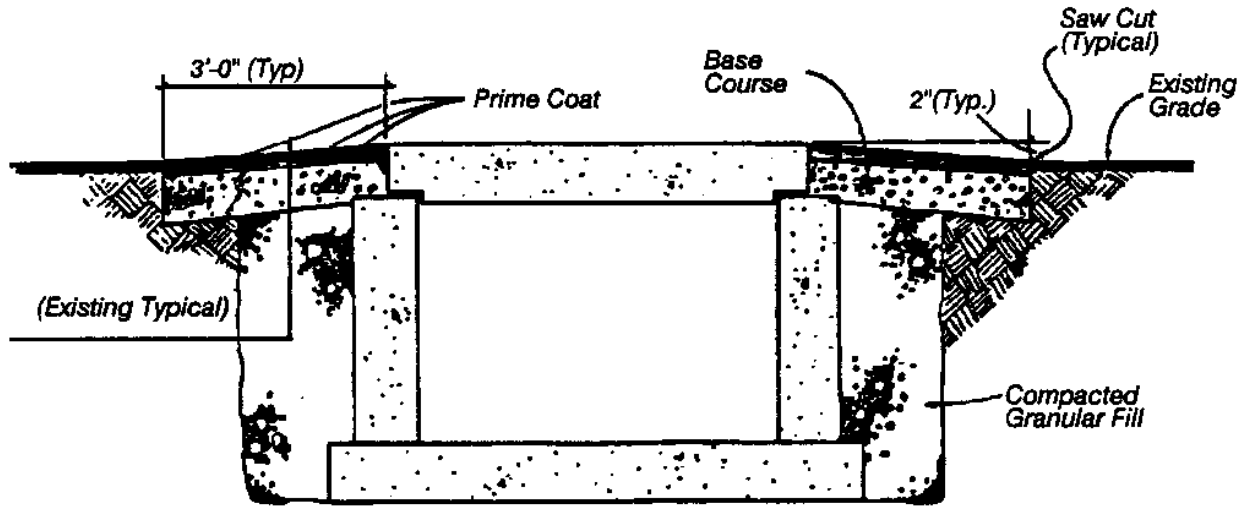

Parking Lot Pavement Cut Detail

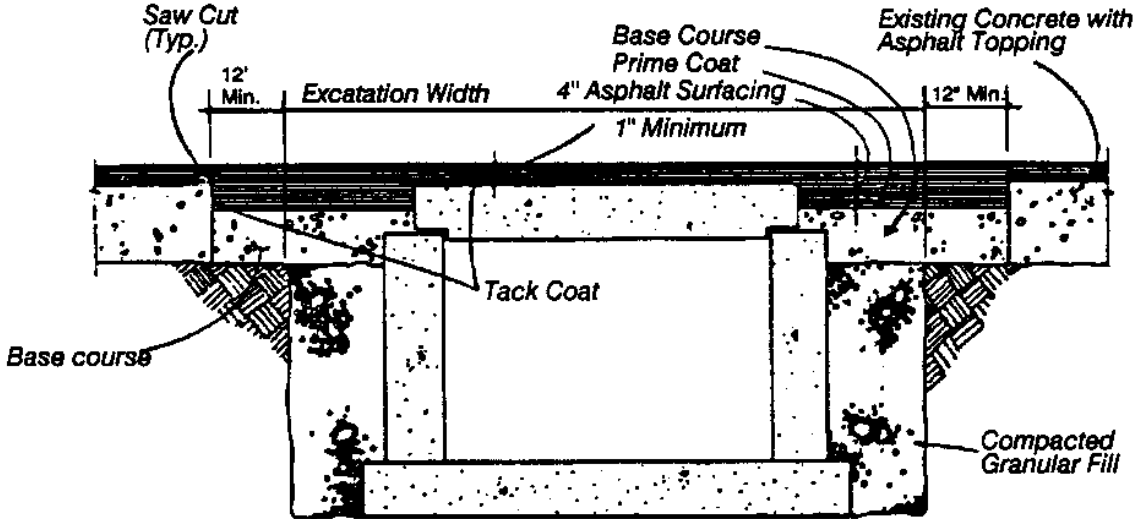

Street Pavement Cut Detail

Figure 13
Concrete Shallow Trench Heat Distribution System
Detail 2

MIL-HDBK-1003/8A

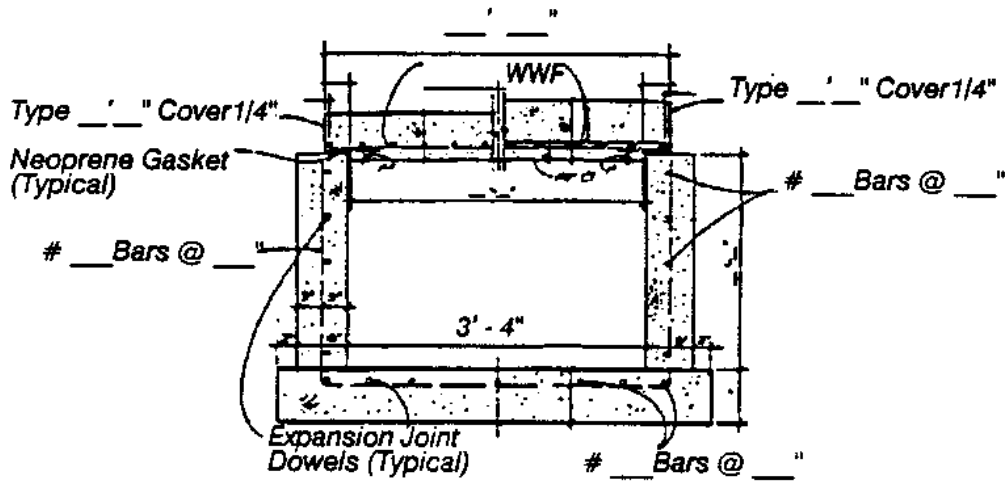

TYPICAL TRENCH

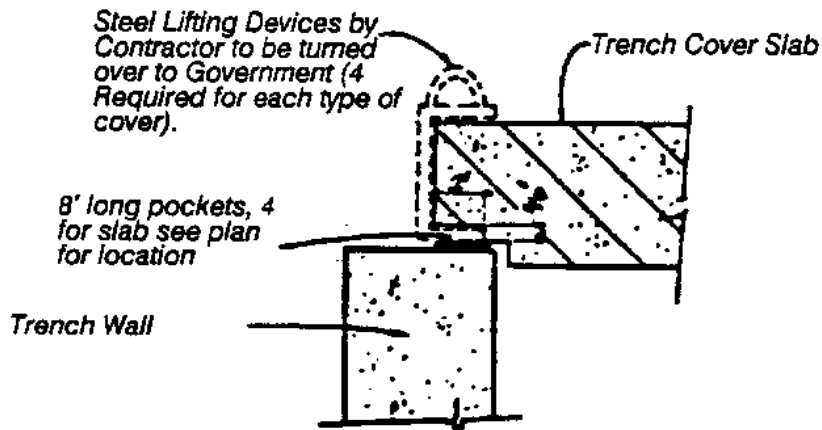

SLAB REMOVAL PROVISION

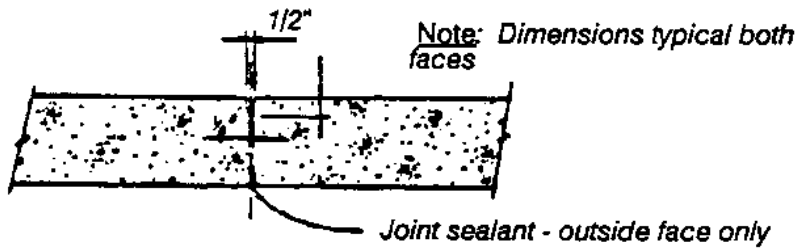

TYPICAL TRENCH WALL CONTROL JOINT
MAXIMUM SPACING 20'0"

Figure 14
Concrete Shallow Trench Heat Distribution System
Detail 3

MIL-HDBK-1003/8A

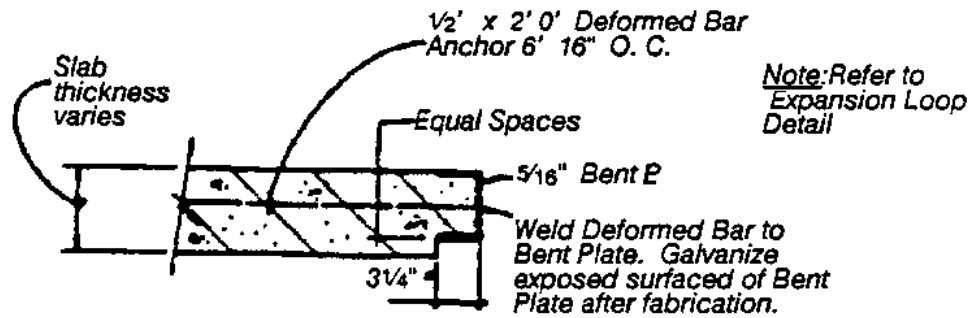

COVER SLAB EDGE REINFORCEMENT AT INTERSECTION

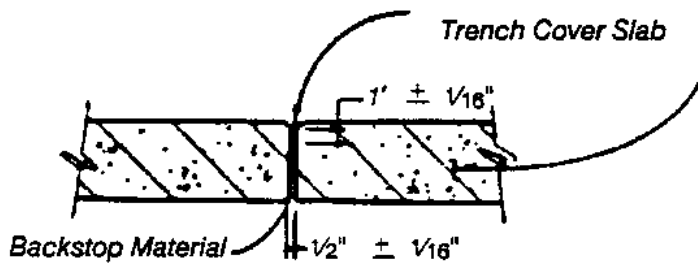

TYPICAL COVER SLAB JOINT

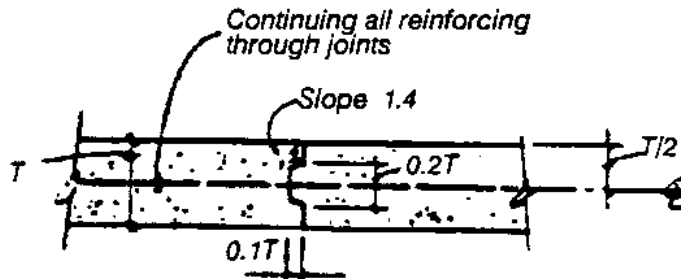

KEYED CONSTRUCTION JOINT BASE SLAB & SIDE WALL

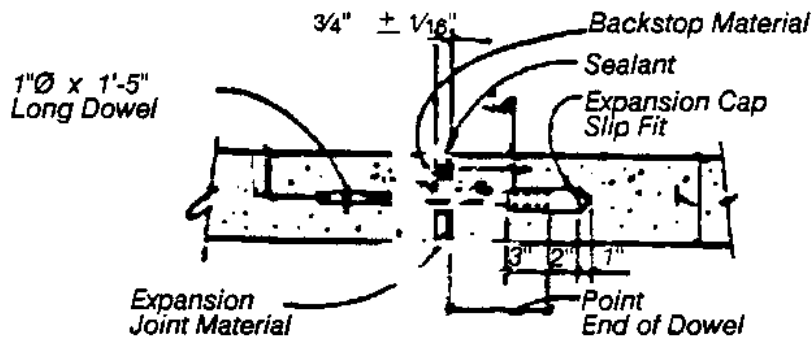

TYPICAL EXPANSION JOINT

Figure 15
Concrete Shallow Trench Heat Distribution System
Detail 4

MIL-HDBK-1003/8A

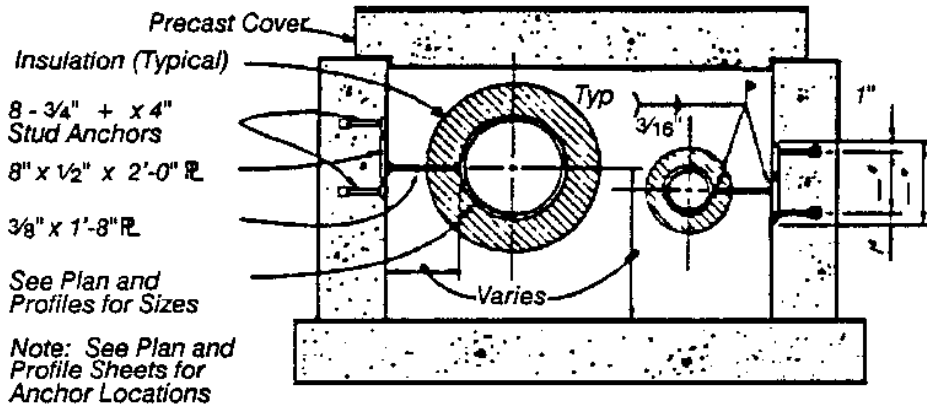

TRENCH PIPE ANCHOR DETAIL

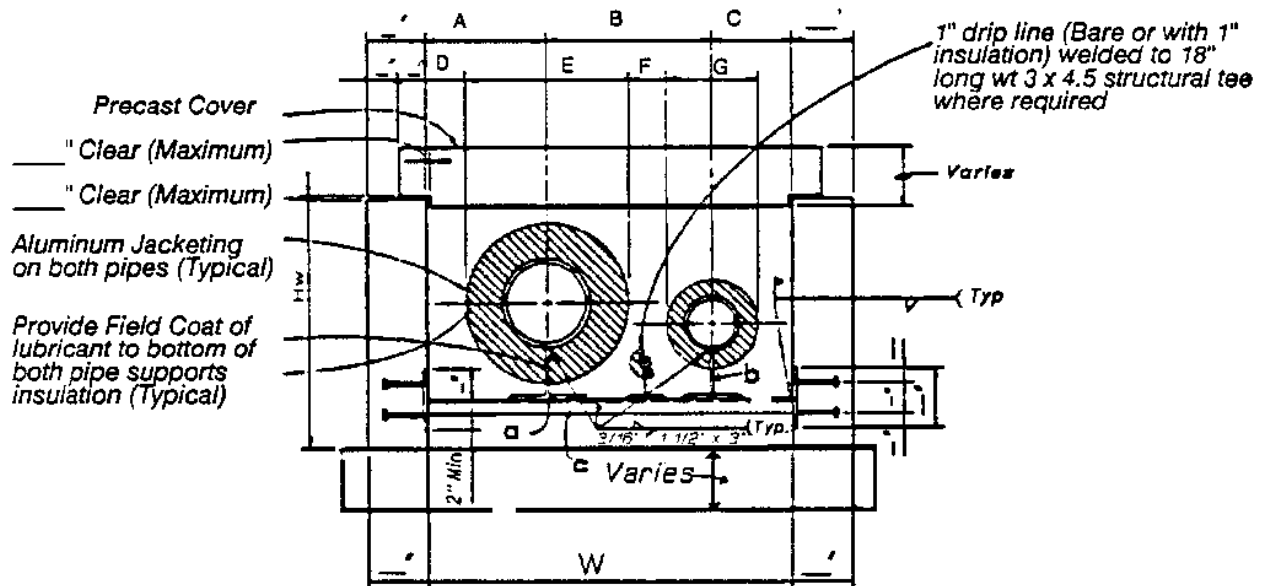

SHALLOW TRENCH PIPE AND SUPPORT DETAIL

Figure 16
Concrete Shallow Trench Heat Distribution System
Detail 5

MIL-HDBK-1003/8A

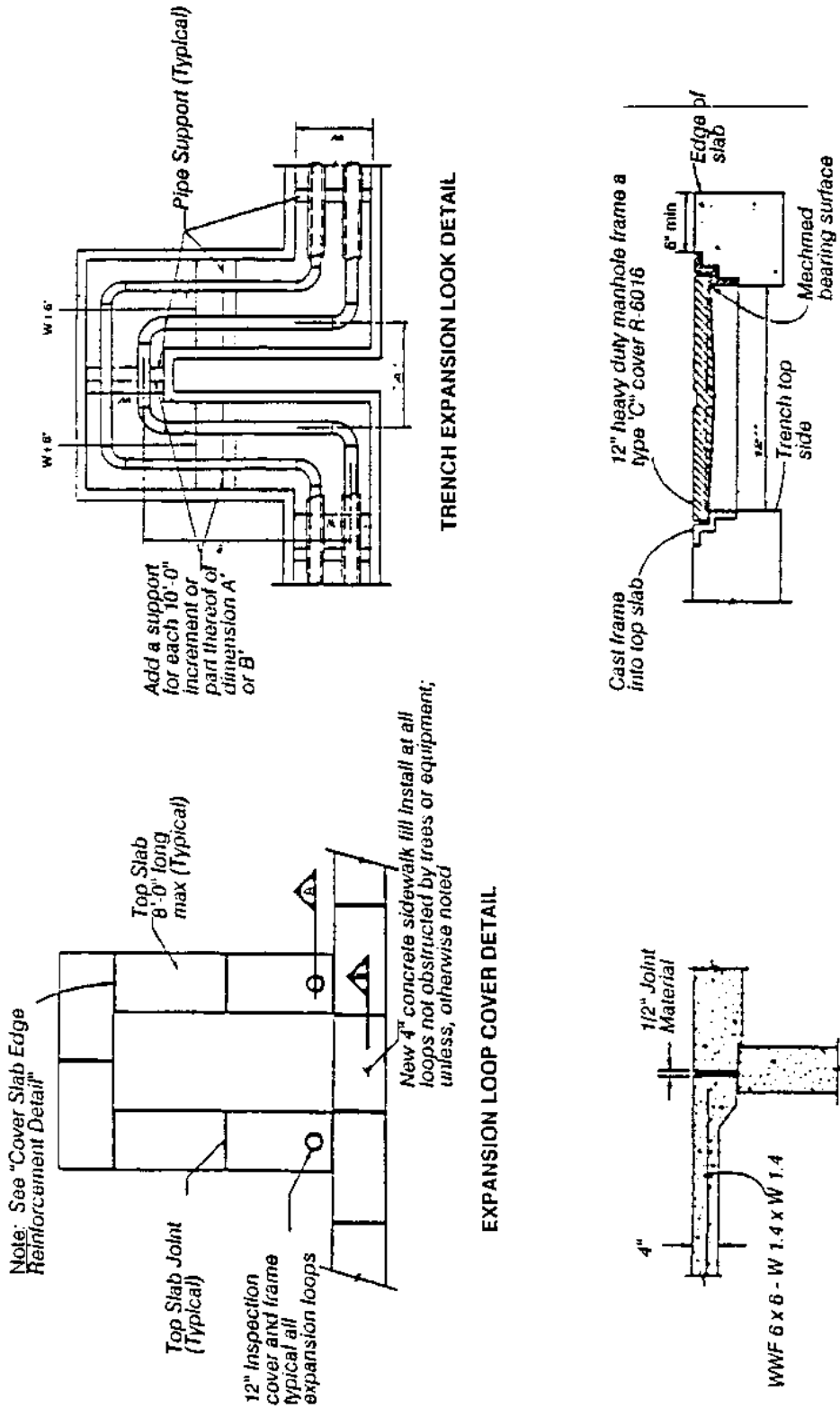

Figure 17
Concrete Shallow Trench Heat Distribution System
Detail 6

MIL-HDBK-1003/8A

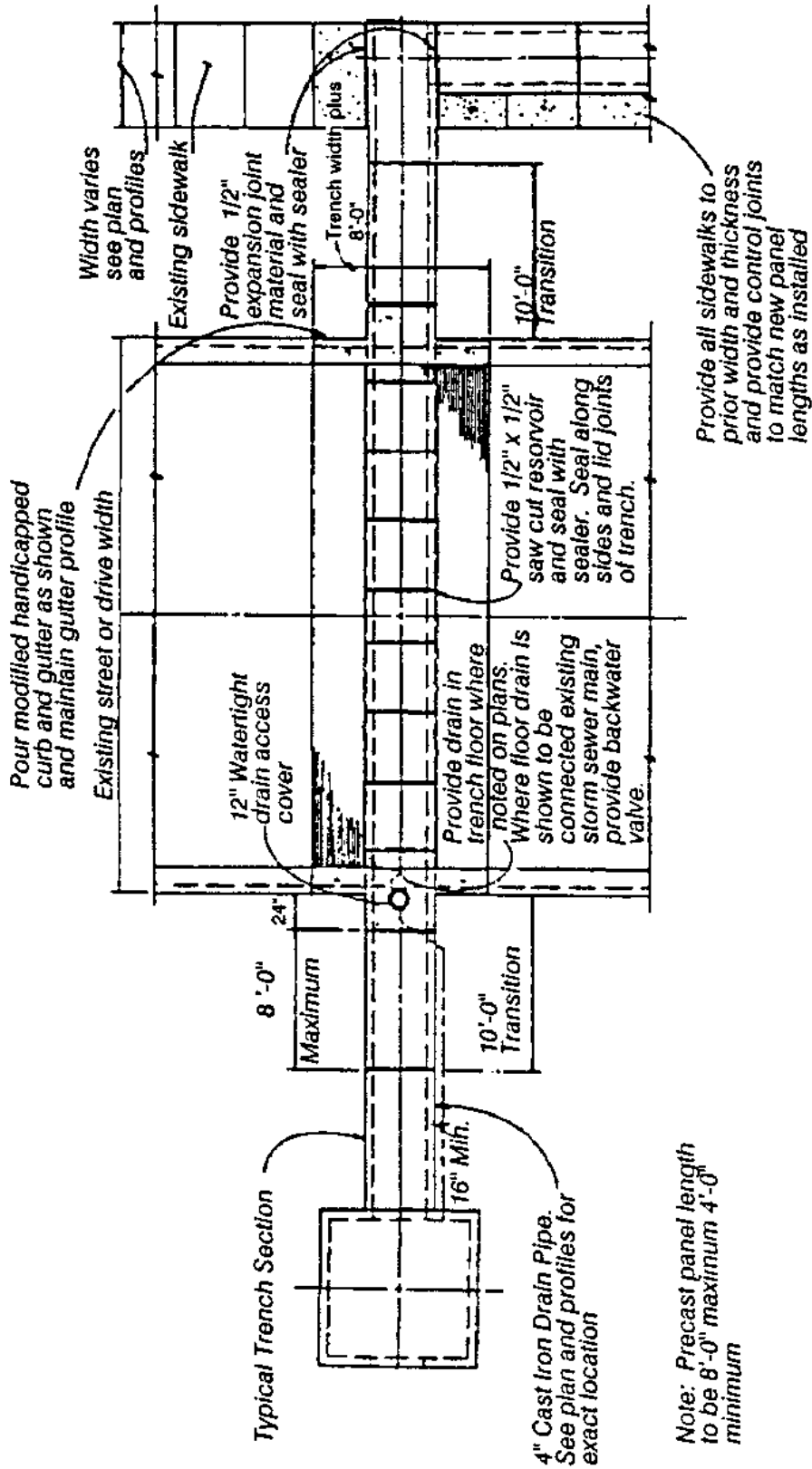

Figure 18
Concrete Shallow Trench Heat Distribution System
Detail 7

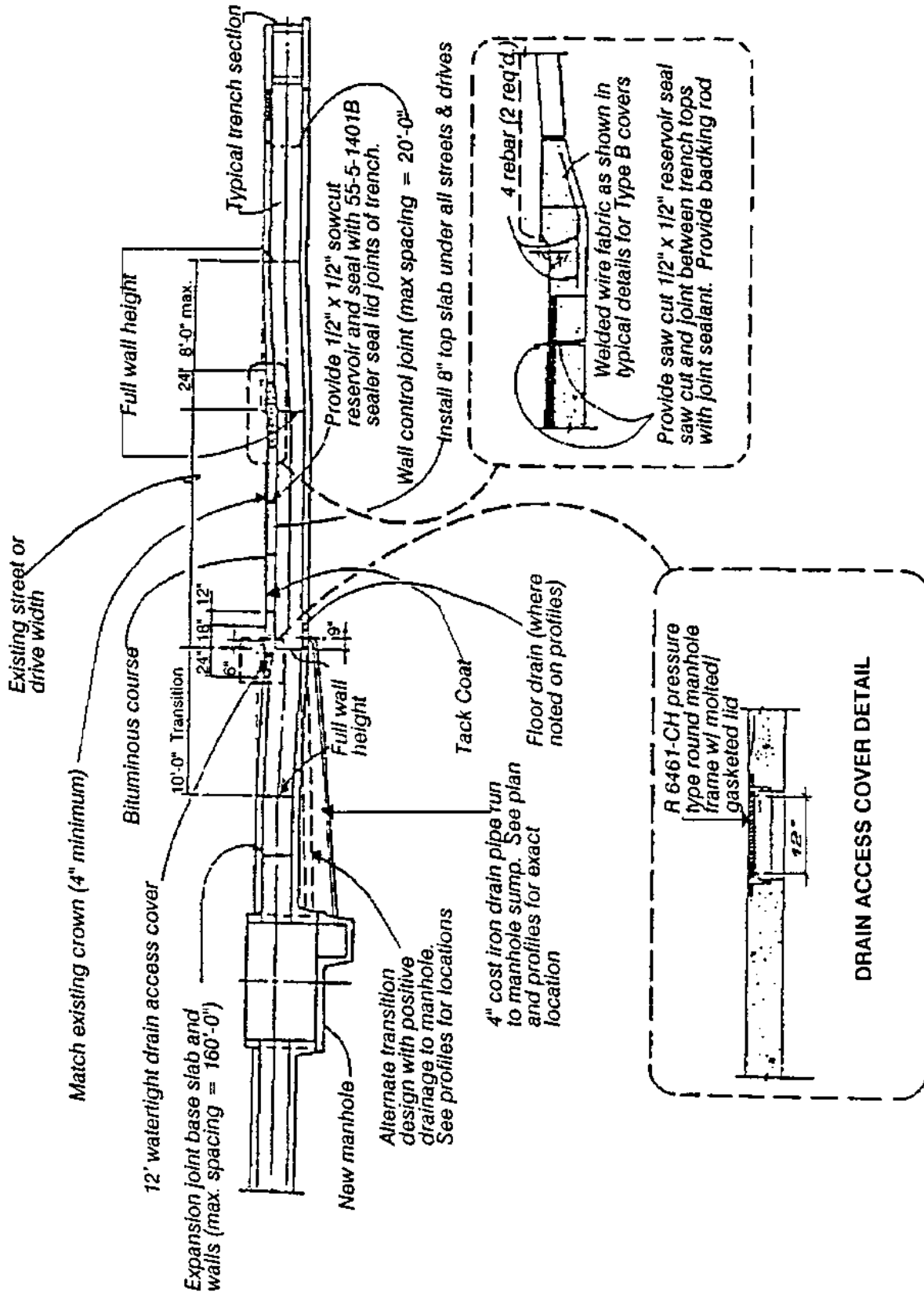
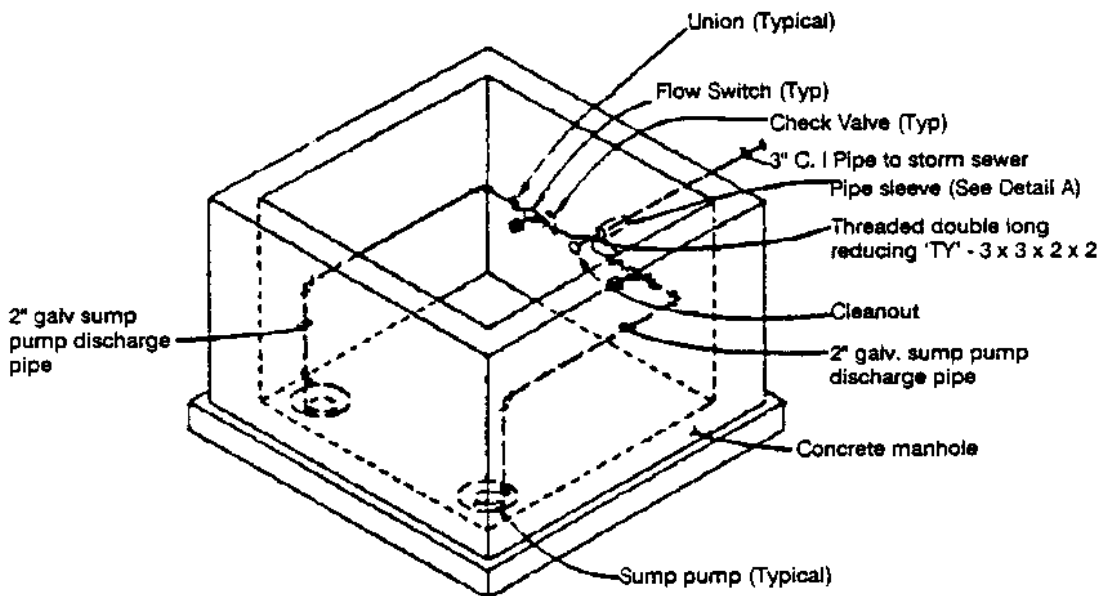

Figure 19
Concrete Shallow Trench Heat Distribution System
Detail 8

MIL-HDBK-1003/8A



TYPICAL SUMP PUMP PIPING TO STORM SEWER

Note: Provide 1 (one) high water level alarm float switch per every two sump pumps in each manhole

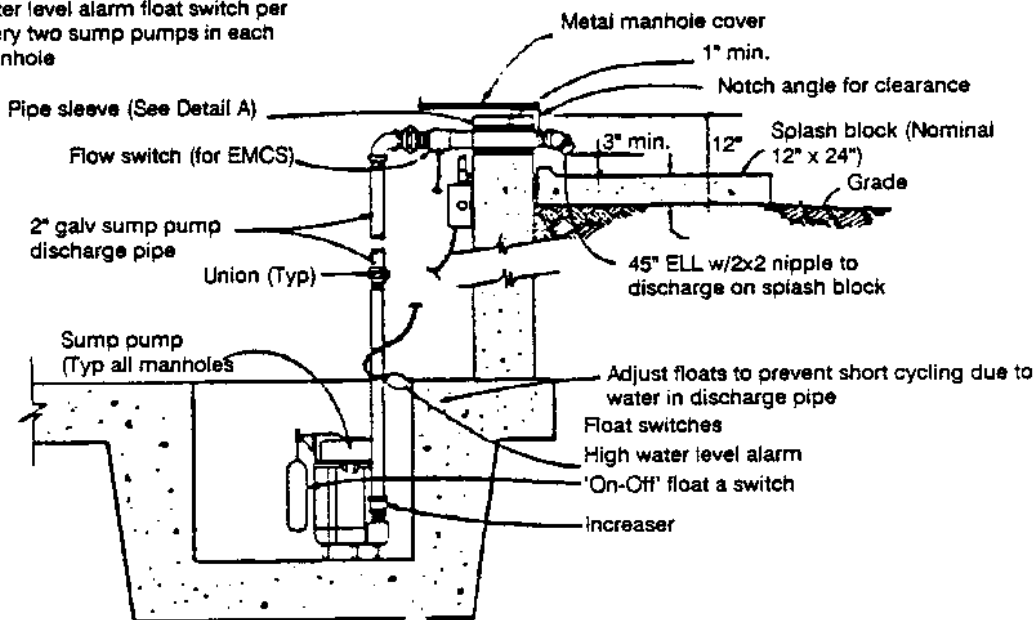

TYPICAL SUMP PUMP PIPING TO SPLASH BLOCK

Figure 20
Concrete Shallow Trench Heat Distribution System
Detail 9

MIL-HDBK-1003/8A

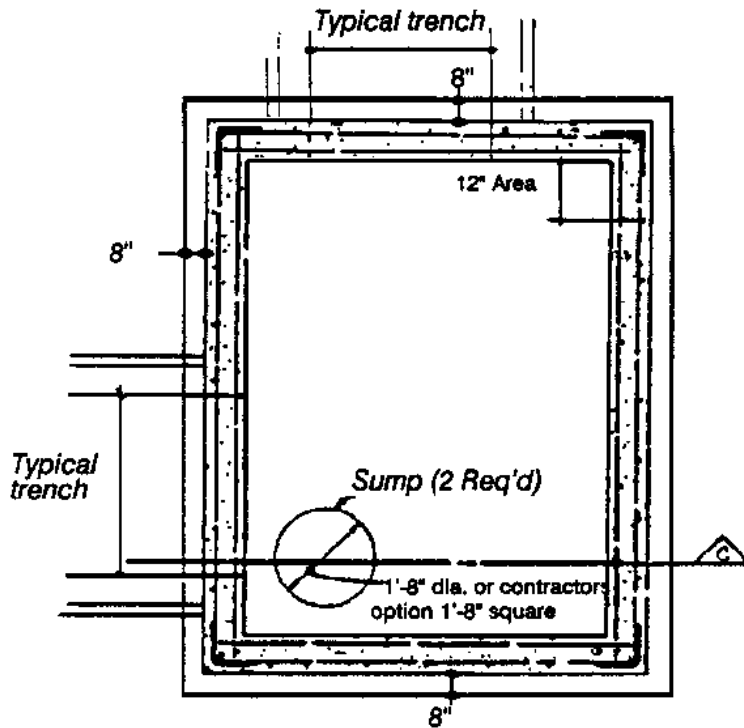

Plan

WALL REINFORCING

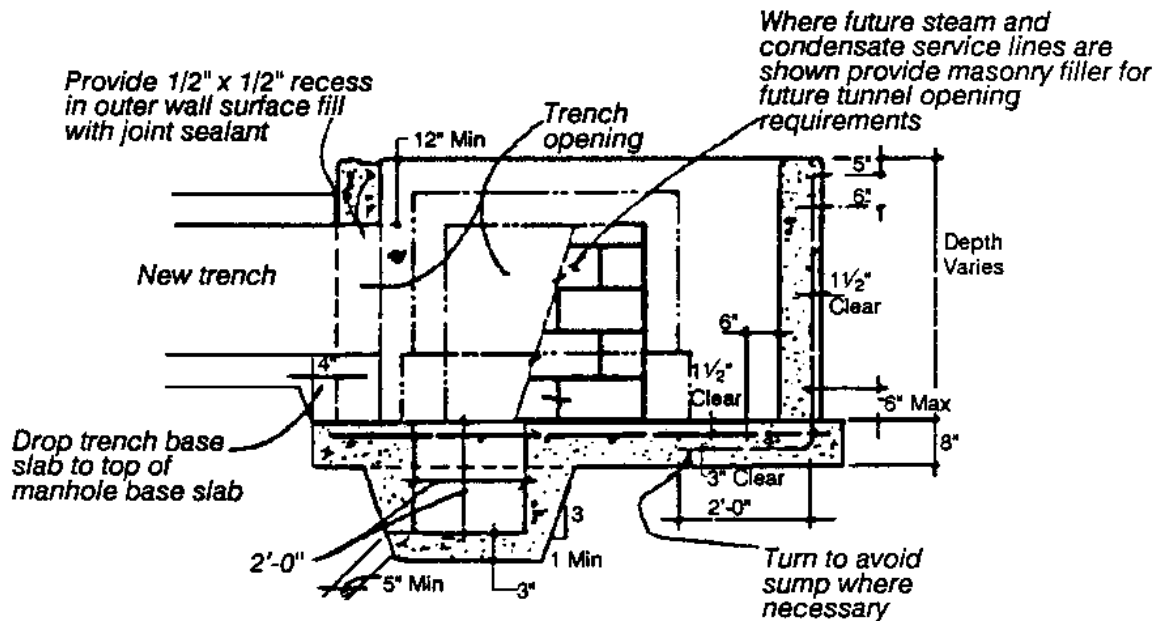

Section C

TYPICAL VALVE MANHOLE DETAILS

Figure 21
Concrete Shallow Trench Heat Distribution System
Detail 10

MIL-HDBK-1003/8A

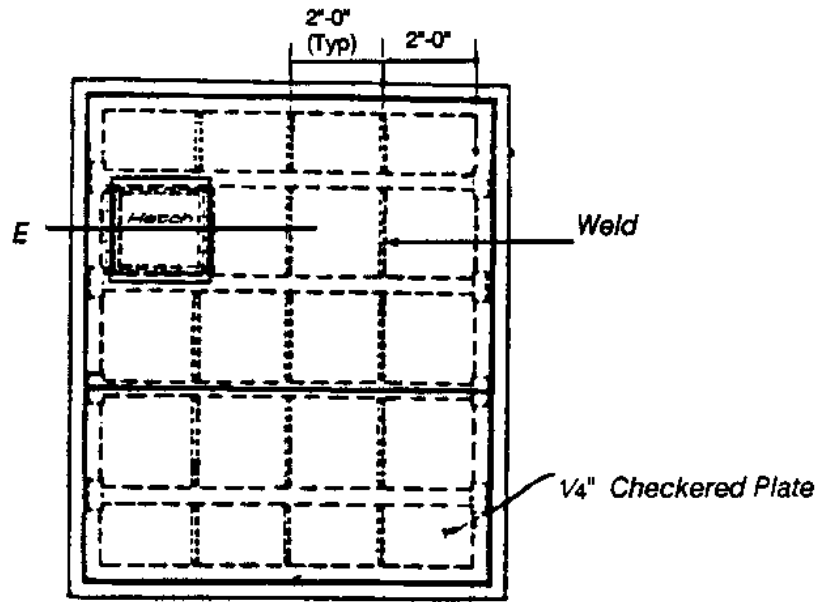

Plan

TYPICAL VALVE MANHOLE COVER IN WALKS

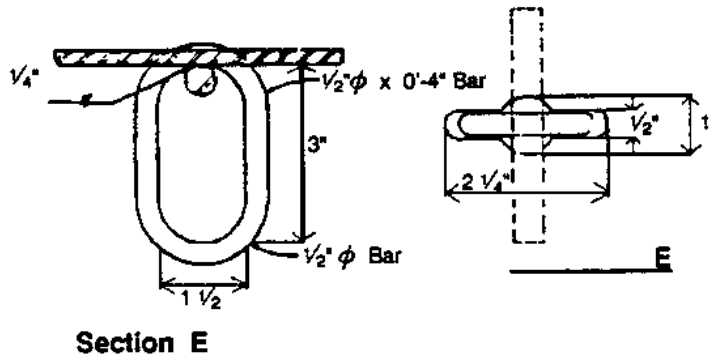
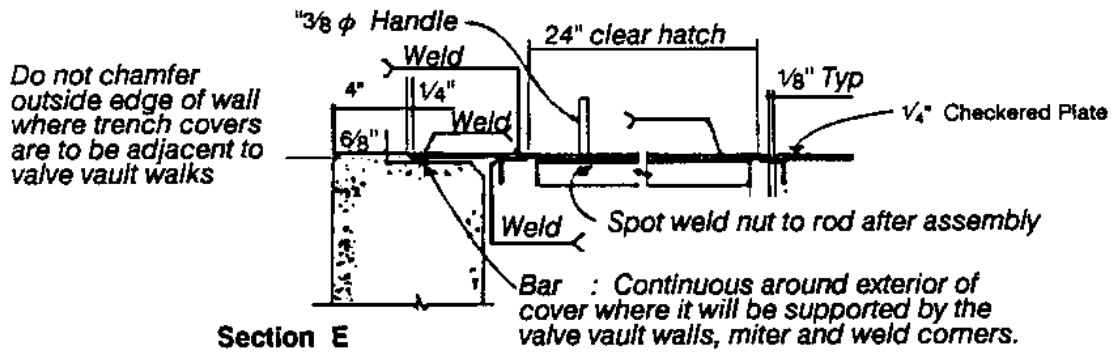

TYPICAL LIFTING DEVICE FOR VALVE MANHOLE COVER IN WALKS

Figure 22
Concrete Shallow Trench Heat Distribution System
Detail 11

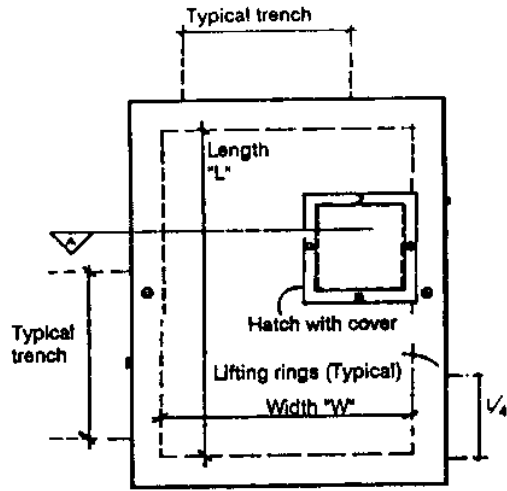

TYPICAL STANDARD VALVE MANHOLE COVER

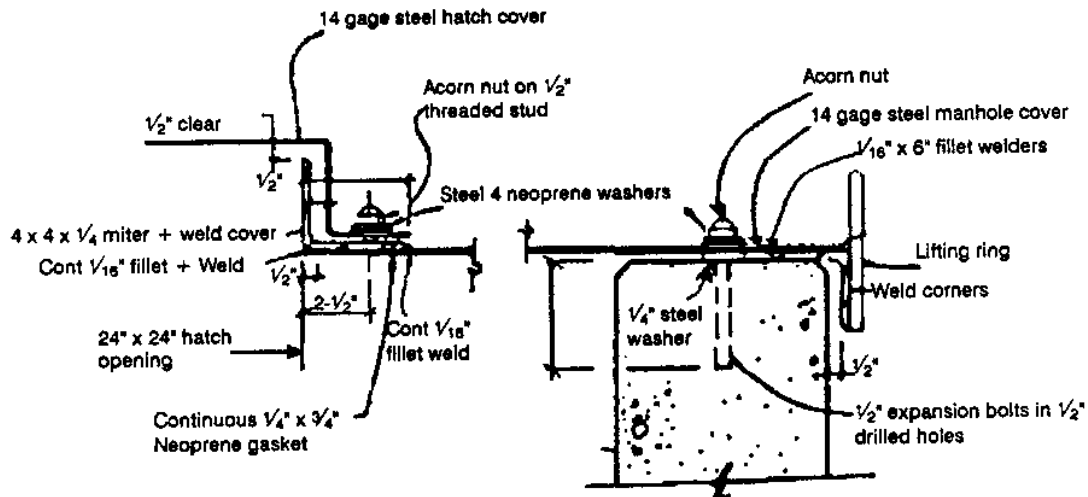

SECTION A

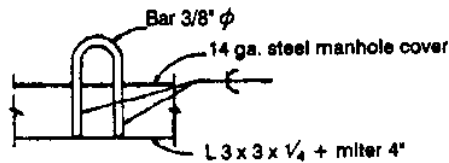

SECTION D

TYPICAL LIFTING RING

Figure 23
Concrete Shallow Trench Heat Distribution System
Detail 12

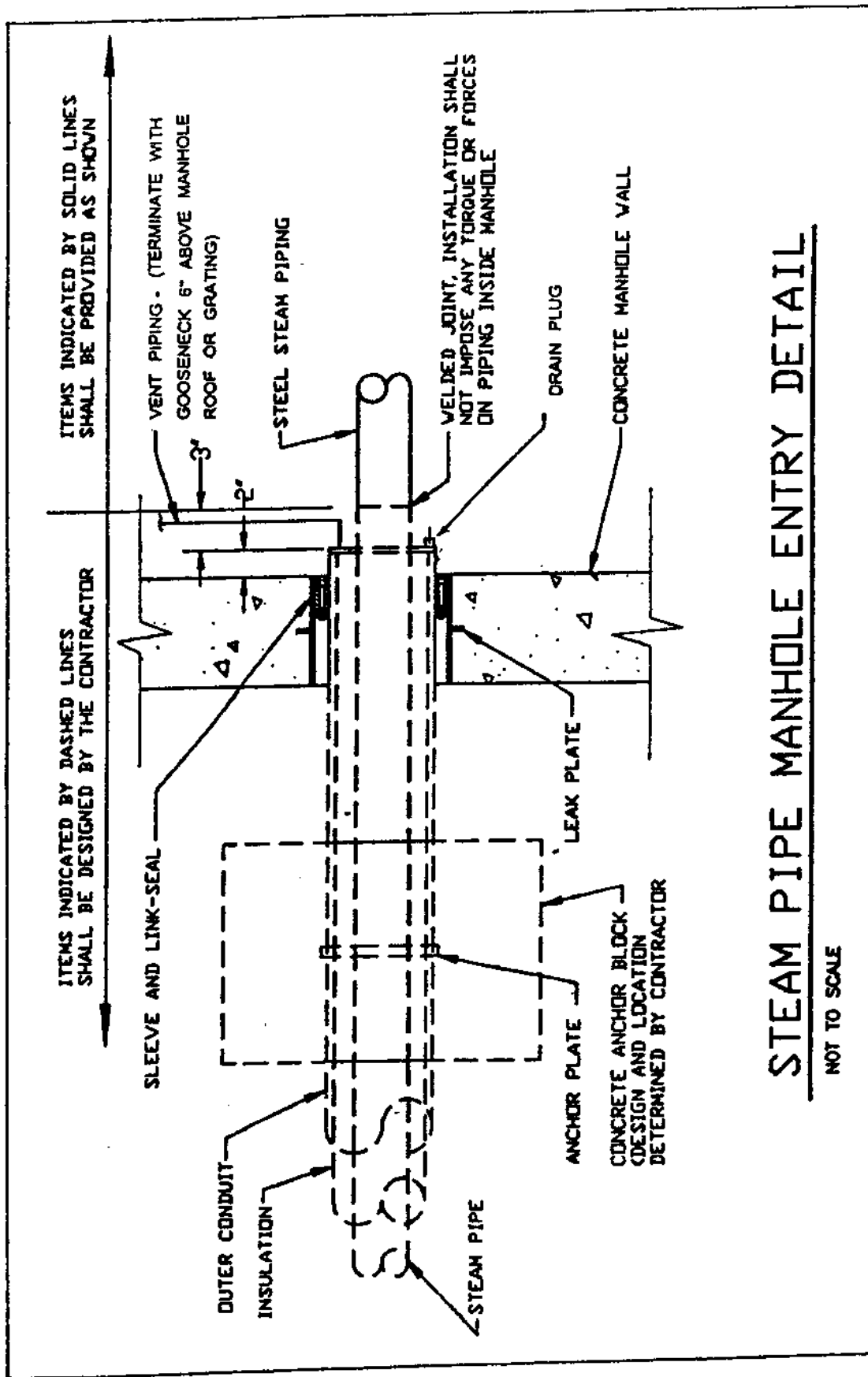

Figure 24
Steel Carrier Piping Manhole Entry Detail
(no scale)

MIL-HDBK-1003/8A

APPENDIX A

HEAT LOSS CALCULATION DATA

PART 1: EARTH THERMAL CONDUCTIVITY FACTORS

The earth thermal conductivity factors (Ke) in Btu-in/(hr) (sq-ft) (degrees F) to be used in the heat loss calculations are as follows:

Moisture Content of Soil	TYPE OF SOIL		
	Sand	Silt	Clay
Low (less than 4% by weight)	2	1	1
Medium (from 4% to 20% by weight)	13	9	7
High (greater than 20% by weight)	15	15	15

Note: Dry soil is exceedingly rare in most parts of the United States, and a low moisture content should be assumed only if the assumption can be proven valid.

MIL-HDBK-1003/8A

APPENDIX A (continued)

PART 2: ENERGY COST AND MAXIMUM PIPE HEAT LOSS

Maximum heat loss, Btu/hr (ft), for each energy cost (EC) in \$/1,000,000 Btu shall be based on the following:

\$2. EC and Maximum Pipe Heat Loss, Btu/hr (ft)

Pipe Size (Inches)	Fluid Temperature (Tf), degrees F							
	150	200	250	300	350	400	450	500
1	15	24	32	41	51	61	59	68
1.25	18	27	38	40	49	58	68	78
1.5	19	30	41	53	53	63	74	85
2	22	35	39	50	61	73	85	98
2.5	26	40	55	57	70	83	83	96
3	30	46	63	65	79	80	94	108
4	36	44	60	76	94	83	98	113
5	41	50	69	88	108	129	128	148
6	46	72	98	100	123	147	172	198
8	58	89	96	123	126	151	176	203
10	53	83	113	144	177	177	180	208
12	60	93	127	162	199	201	235	237
14	64	100	136	174	213	254	297	292
16	71	110	150	192	235	239	280	322
18	78	120	164	155	190	227	236	272

\$3. EC and Maximum Pipe Heat Loss, Btu/hr (ft)

Pipe Size (Inches)	Fluid Temperature (Tf), degrees F							
	150	200	250	300	350	400	450	500
1	15	24	27	34	42	50	59	68
1.25	18	27	31	40	49	58	68	78
1.5	19	30	34	43	53	63	74	85
2	18	28	39	50	61	73	66	69
2.5	26	40	44	57	59	71	67	77
3	30	46	50	55	67	80	75	87
4	28	44	60	57	70	83	98	113
5	32	50	69	88	92	97	113	130
6	46	72	78	100	123	108	127	146
8	45	70	80	103	126	151	137	144
10	53	83	113	121	129	154	180	168
12	60	93	127	137	147	156	183	211
14	64	100	136	174	181	216	219	253
16	71	110	150	163	200	208	217	226
18	78	120	121	155	169	202	215	247

MIL-HDBK-1003/8A

APPENDIX A (continued)

§4. EC and Maximum Pipe Heat Loss, Btu/hr (ft)

Pipe Size (Inches)	Fluid Temperature (Tf), degrees F							
	150	200	250	300	350	400	450	500
1	15	24	27	34	42	50	59	60
1.25	18	22	31	40	49	58	59	62
1.5	19	24	34	43	53	45	53	61
2	18	28	39	50	43	51	60	69
2.5	26	32	44	48	59	63	67	77
3	30	37	43	55	67	64	75	87
4	28	44	44	57	70	83	98	113
5	32	50	58	75	81	97	113	117
6	46	57	78	74	91	108	114	120
8	45	59	80	103	126	106	125	144
10	53	83	94	105	129	124	146	168
12	60	93	107	106	131	156	165	190
14	64	100	136	148	157	187	219	253
16	71	110	128	163	155	167	196	192
18	78	89	121	138	154	183	215	247

§5. EC and Maximum Pipe Heat Loss, Btu/hr (ft)

Pipe Size (Inches)	Fluid Temperature (Tf), degrees F							
	150	200	250	300	350	400	450	500
1	15	19	27	34	42	44	52	50
1.25	18	22	31	40	38	42	49	57
1.5	15	24	34	31	38	45	53	61
2	18	28	27	35	43	51	60	69
2.5	21	27	38	43	48	57	67	77
3	24	31	43	44	54	64	75	87
4	28	32	44	57	70	69	81	94
5	32	43	51	66	81	87	101	117
6	37	57	58	74	82	89	104	120
8	45	59	80	73	89	106	125	123
10	53	69	82	85	104	124	125	144
12	60	69	83	106	118	130	118	136
14	64	100	100	128	157	151	163	174
16	71	94	99	114	140	142	166	192
18	57	79	108	125	154	183	182	184

MIL-HDBK-1003/8A

APPENDIX A (continued)

§6. EC and Maximum Pipe Heat Loss, Btu/hr (ft)

Pipe Size (Inches)	Fluid Temperature (Tf), degrees F							
	150	200	250	300	350	400	450	500
1	15	19	27	34	37	44	52	50
1.25	14	22	31	31	35	42	49	57
1.5	16	24	34	31	38	45	53	61
2	18	28	27	35	43	51	60	69
2.5	21	27	34	39	48	57	67	77
3	20	31	34	44	54	64	75	87
4	28	32	44	57	70	69	81	94
5	32	43	51	66	72	87	101	99
6	37	42	58	67	74	89	104	120
8	38	59	63	73	89	106	107	123
10	53	60	82	85	104	115	125	144
12	60	69	83	96	109	100	118	136
14	64	84	100	128	127	139	151	153
16	71	94	89	114	119	142	166	192
18	57	79	98	125	154	155	159	184

§7. EC and Maximum Pipe Heat Loss, Btu/hr (ft)

Pipe Size (Inches)	Fluid Temperature (Tf), degrees F							
	150	200	250	300	350	400	450	500
1	12	19	27	34	37	44	44	50
1.25	14	22	31	29	35	42	49	57
1.5	16	24	24	31	38	45	53	61
2	18	22	27	35	43	51	60	69
2.5	21	24	30	39	48	57	67	77
3	20	31	34	44	54	64	75	87
4	21	32	44	57	58	69	81	94
5	32	38	51	59	72	87	86	99
6	37	42	58	61	74	89	104	104
8	38	59	57	73	89	91	107	110
10	44	60	66	85	96	106	125	121
12	51	61	83	89	84	100	118	136
14	64	84	100	103	117	129	133	153
16	60	72	89	97	119	142	166	160
18	57	72	98	125	130	136	159	184

MIL-HDBK-1003/8A

APPENDIX A (continued)

§8. EC and Maximum Pipe Heat Loss, Btu/hr (ft)

Pipe Size (Inches)	Fluid Temperature (Tf), degrees F							
	150	200	250	300	350	400	450	500
1	12	19	27	30	37	37	44	50
1.25	14	22	31	29	35	42	43	57
1.5	16	24	24	31	38	45	53	61
2	18	22	27	35	43	51	60	69
2.5	21	24	30	39	48	57	67	77
3	20	25	34	44	54	64	75	75
4	21	32	44	47	58	69	81	94
5	27	38	51	59	72	87	86	99
6	37	42	52	61	74	89	90	104
8	38	46	57	73	77	91	95	110
10	44	60	66	85	89	106	105	121
12	44	61	75	89	84	100	118	136
14	64	73	100	103	108	113	133	153
16	60	65	89	97	119	142	138	160
18	57	72	98	106	130	136	159	184

§9. EC and Maximum Pipe Heat Loss, Btu/hr (ft)

Pipe Size (Inches)	Fluid Temperature (Tf), degrees F							
	150	200	250	300	350	400	450	500
1	12	19	27	30	31	37	44	50
1.25	14	22	24	29	35	42	49	57
1.5	16	24	24	31	38	45	53	61
2	18	20	27	35	43	51	60	64
2.5	18	22	30	39	48	57	67	72
3	20	25	34	44	54	64	65	75
4	21	32	44	47	58	69	81	94
5	27	38	46	59	72	74	86	99
6	37	42	52	61	74	77	90	98
8	38	46	57	73	77	81	95	110
10	39	48	66	85	89	106	105	121
12	44	61	75	69	84	100	118	136
14	54	73	81	95	108	113	133	153
16	60	65	76	97	119	118	138	160
18	51	72	98	106	114	136	159	173

MIL-HDBK-1003/8A

APPENDIX A (continued)

PART 3: EARTH TEMPERATURES

The earth temperatures (T_e) to be used in the heat loss calculations are listed below. The list presents the average earth temperature from 0 to 10 feet below the surface for the four seasons of the year and for the whole year for the indicated locale. The temperatures were computed on the basis of the method described in the 1965 ASHRAE technical paper entitled "Earth Temperature and Thermal Diffusivity at Selected Stations in the United States" by T. Kusuda and P. R. Achenback (in ASHRAE Transactions, Volume 71, Part 1, p. 61, 1965) using the monthly average air temperatures published by the U.S. Weather Bureau for the listed localities in the United States. Earth temperatures are expressed in Fahrenheit degrees. AP refers to airport data, CO to city office data, COOP to cooperative weather station data, and OBS to observation station data. When data is not available for exact project location, use nearest location shown in following table.

Location	Winter	Spring	Summer	Autumn	Annual
Alabama					
Anniston AP	55	58	70	67	63
Birmingham AP	54	58	71	68	63
Mobile AP	61	63	74	71	67
Mobile CO	61	64	75	72	68
Montgomery AP	58	61	73	70	65
Montgomery CO	59	62	74	71	66
Arizona					
Bisbee COOP	55	58	70	67	62
Flagstaff AP	35	39	54	50	45
Ft Huachuca (proving ground)	55	58	71	68	63
Phoenix AP	60	64	79	75	69
Phoenix CO	61	65	80	76	70
Prescott AP	46	49	65	61	55
Tuscon AP	59	62	76	73	68
Winslow AP	45	49	65	61	55
Yuma AP	65	69	84	80	75
Arkansas					
Fort Smith AP	52	46	72	68	62
Little Rock AP	53	57	72	68	62
Texarkana AP	56	60	74	71	65

MIL-HDBK-1003/8A

APPENDIX A (continued)

Location	Winter	Spring	Summer	Autumn	Annual
California					
Bakersfield AP	56	60	74	70	65
Beaumont CO	53	56	67	64	60
Bishop AP	47	51	65	61	56
Blue Canyon AP	43	46	58	55	50
Burbank AP	58	60	68	66	63
Eureka CO	50	51	54	54	52
Fresno AP	54	58	72	68	63
Los Angeles AP	58	59	64	63	61
Los Angeles CO	60	61	68	66	64
Mount Shasta CO	41	44	57	54	49
Oakland AP	53	54	60	59	56
Red Bluff AP	54	58	72	69	63
Sacramento AP	53	56	67	64	60
Sacramento CO	54	57	68	65	61
Sandberg CO	47	50	63	60	55
San Diego AP	59	60	66	65	62
San Francisco AP	53	54	59	57	56
San Francisco CO	55	55	59	58	57
San Jose COOP	55	57	64	62	59
Santa Catalina AP	57	58	64	62	60
Santa Maria AP	54	55	60	59	57
Colorado					
Alamosa AP	30	35	52	48	41
Colorado Springs AP	39	43	59	55	49
Denver AP	39	43	60	56	50
Denver CO	41	45	61	58	51
Grand Junction AP	39	44	65	60	52
Pueblo AP	41	45	62	58	51
Connecticut					
Bridgeport AP	40	44	61	57	50
Hartford AP	39	43	61	57	50
Hartford AP (Brainer)	39	43	60	56	50
New Haven AP	40	44	60	56	50
Delaware					
Wilmington AP	44	48	64	60	54
Washington D.C.					
Washington AP	47	51	66	63	56
Washington CO	47	51	66	63	57
Silver Hill OBS	46	50	65	61	55

MIL-HDBK-1003/8A

APPENDIX A (continued)

Location	Winter	Spring	Summer	Autumn	Annual
Florida					
Apalachicola CO	63	65	75	73	69
Daytona Beach AP	65	67	75	74	70
Fort Myers AP	70	71	78	76	74
Jacksonville AP	63	66	75	73	69
Jacksonville CO	64	66	76	73	70
Key West AP	74	75	80	79	77
Key West CO	75	76	81	79	78
Lakeland CO	68	69	77	75	72
Melbourne AP	68	70	77	75	72
Miami AP	72	74	79	78	76
Miami CO	72	73	78	77	75
Miami Beach COOP	74	75	80	78	77
Orlando AP	68	70	77	75	72
Pensacola CO	62	64	74	72	68
Tallahassee AP	61	64	74	72	68
Tampa AP	68	69	77	75	72
West Palm Beach	71	73	79	77	75
Georgia					
Albany AP	60	63	75	72	67
Athens AP	54	58	71	68	63
Atlanta AP	54	57	70	67	62
Atlanta CO	54	57	70	67	62
Augusta AP	56	59	72	69	64
Columbus AP	56	59	72	69	64
Macon AP	58	61	74	71	66
Rome AP	53	56	70	67	61
Savannah AP	60	63	74	71	67
Thomasville CO	62	64	74	72	68
Valdosta AP	61	64	74	72	68
Idaho					
Boise AP	40	44	62	58	51
Idaho Falls 46 W	30	35	55	50	42
Idaho Falls 42 N W	28	33	54	49	41
Lewiston AP	42	46	63	59	52
Pocatello AP	35	40	59	55	44
Salmon CO	32	37	56	52	44

MIL-HDBK-1003/8A

APPENDIX A (continued)

Location	Winter	Spring	Summer	Autumn	Annual
Illinois					
Cairo CO	49	53	70	66	60
Chicago AP	38	43	62	57	50
Joliet AP	37	42	61	56	49
Moline AP	38	43	62	58	50
Peoria AP	39	44	63	58	51
Springfield AP	41	45	64	60	52
Springfield CO	43	47	66	62	54
Indiana					
Evansville AP	47	51	67	63	57
Fort Wayne AP	39	43	61	57	50
Indianapolis AP	41	46	64	59	52
Indianapolis CO	43	48	65	61	54
South Bend AP	38	42	61	56	49
Terre Haute AP	42	47	65	60	53
Iowa					
Burlington AP	39	44	64	59	51
Charles City CO	33	38	60	55	46
Davenport CO	39	44	64	59	51
Des Moines AP	37	42	63	58	50
Des Moines CO	38	43	64	59	51
Dubuque AP	34	39	60	55	47
Sioux City	35	40	62	57	49
Waterloo AP	35	40	61	56	48
Kansas					
Concordia CO	42	47	67	62	54
Dodge City AP	43	48	67	62	55
Goodland AP	38	43	62	57	50
Topeka AP	43	47	66	62	55
Topeka CO	44	49	68	63	56
Wichita AP	45	50	68	64	57
Kentucky					
Bowling Green AP	47	51	67	63	57
Lexington AP	44	48	65	61	54
Louisville AP	46	50	67	63	56
Louisville CO	47	51	67	64	57

MIL-HDBK-1003/8A

APPENDIX A (continued)

Location	Winter	Spring	Summer	Autumn	Annual
Louisiana					
Baton Rouge AP	61	63	74	72	67
Burrwood CO	65	67	77	74	71
Lake Charles AP	61	64	75	73	68
New Orleans AP	63	65	75	73	69
New Orleans CO	64	66	77	74	70
Shreveport AP	58	61	75	72	66
Maine					
Caribou AP	24	29	50	45	37
Eastport CO	33	37	51	48	42
Portland AP	33	38	56	51	44
Maryland					
Baltimore AP	45	49	65	61	55
Baltimore CO	47	51	67	63	57
Frederick AP	44	48	65	61	55
Massachusetts					
Boston AP	41	44	61	57	51
Nantucket AP	41	44	57	54	49
Pittsfield AP	34	38	55	51	44
Worcester AP	36	40	58	54	47
Michigan					
Alpena CO	33	37	54	50	43
Detroit Willow Run AP	38	42	60	56	49
Detroit City AP	38	43	60	56	49
Escanaba CO	30	35	53	49	42
Flint AP	36	40	58	54	47
Grand Rapids AP	36	40	58	54	47
Grand Rapids CO	38	42	60	56	49
East Lansing CO	36	40	58	54	47
Marquette CO	31	35	53	49	42
Muskecon AP	36	40	57	53	47
Sault Ste Marie AP	28	32	51	47	39
Minnesota					
Crookston COOP	25	31	55	49	40
Duluth AP	25	30	52	47	38
Duluth CO	26	31	52	47	39
International Falls	22	27	51	45	36
Minneapolis AP	32	37	60	54	46

MIL-HDBK-1003/8A

APPENDIX A (continued)

Location	Winter	Spring	Summer	Autumn	Annual
Rochester AP	31	36	58	53	44
Saint Cloud AP	28	33	56	51	42
Saint Paul AP	32	37	60	54	46
Mississippi					
Jackson AP	57	61	73	70	65
Meridian AP	57	60	72	69	64
Vicksburg CO	58	61	74	71	66
Missouri					
Columbia AP	43	48	66	62	55
Kansas City AP	55	49	68	64	56
Saint Joseph AP	42	47	67	72	54
Saint Louis AP	45	49	67	63	56
Saint Louis CO	46	50	68	64	57
Springfield AP	45	49	66	62	56
Montana					
Billings AP	35	40	59	55	47
Butte AP	27	31	50	45	38
Glasgow AP	27	33	56	51	42
Glasgow CO	28	34	57	52	43
Great Falls AP	34	38	56	52	45
Harve CO	31	36	57	52	44
Helena AP	31	36	55	50	43
Helena CO	32	36	55	50	43
Kalispell AP	32	37	54	50	43
Miles City AP	32	37	59	54	45
Missoula AP	33	37	56	51	44
Nebraska					
Grand Island AP	38	43	64	59	51
Lincoln AP	39	44	64	60	52
Lincoln					
University CO	40	45	65	61	53
Norfolk AP	35	40	62	57	48
North Platte AP	37	42	62	57	49
Omaha AP	39	44	65	60	52
Scottsbluff AP	36	41	60	56	48
Valentine CO	35	40	61	56	48
Nevada					
Elko AP	34	39	57	53	46
Ely AP	35	39	56	52	45

MIL-HDBK-1003/8A

APPENDIX A (continued)

Location	Winter	Spring	Summer	Autumn	Annual
Las Vegas AP	56	60	78	74	67
Reno AP	40	44	58	55	49
Tonopah	41	56	61	57	51
Winnemucca AP	38	42	60	56	49
New Hampshire					
Concord AP	33	38	56	52	45
Mt Washington COOP	17	21	37	33	27
New Jersey					
Atlantic City CO	45	49	63	60	54
Newark AP	43	47	63	59	53
Trenton CO	43	47	64	60	53
New Mexico					
Albuquerque AP	46	50	67	63	57
Clayton AP	43	47	63	59	53
Raton AP	38	42	58	54	48
Roswell AP	51	54	69	66	60
New York					
Albany AP	36	40	59	54	47
Albany CO	38	43	61	56	49
Bear Mountain CO	38	42	59	55	48
Binghamton AP	34	38	56	52	45
Binghamton CO	38	42	59	55	48
Buffalo AP	37	41	58	54	47
New York AP (La Guardia)	44	48	64	60	54
New York CO	44	47	63	59	53
New York Central Park	44	48	64	60	54
Oswego CO	36	40	58	54	47
Rochester AP	37	41	58	54	47
Schenectady COOP	35	40	59	55	47
Syracuse AP	38	42	60	56	49
North Carolina					
Asheville CO	48	51	64	61	56
Charlotte AP	52	55	69	66	60
Greensboro AP	49	53	67	64	58
Hatteras CO	56	59	70	68	63
Raleigh AP	51	55	69	65	60
Raleigh CO	52	56	70	66	61

MIL-HDBK-1003/8A

APPENDIX A (continued)

Location	Winter	Spring	Summer	Autumn	Annual
Wilmington AP	56	59	71	69	64
Winston Salem AP	50	53	67	64	58
North Dakota					
Bismarck AP	27	33	56	51	42
Devils Lake CO	24	29	54	48	39
Fargo AP	26	32	56	50	41
Minot AP	25	31	54	49	39
Williston CO	27	33	56	50	41
Ohio					
Akron-Canton AP	39	43	60	56	50
Cincinnati AP	43	47	64	60	54
Cincinnati CO	46	50	66	63	56
Cincinnati ABBE OBS	45	49	65	61	55
Cleveland AP	40	44	61	57	51
Cleveland CO	41	45	62	58	51
Columbus AP	41	46	62	59	52
Columbus CO	43	47	64	60	53
Dayton AP	42	46	63	59	52
Sandusky CC	41	45	62	58	51
Toledo AP	38	43	60	56	49
Youngstown AP	39	43	60	56	50
Oklahoma					
Oklahoma City AP	50	54	71	67	60
Oklahoma City CO	50	55	71	68	61
Tulsa AP	50	54	71	67	61
Oregon					
Astoria AP	47	48	56	54	51
Baker CO	36	40	56	52	46
Burns CO	36	40	58	54	47
Eugene AP	46	48	59	57	52
Meacham AP	34	38	52	49	43
Medford AP	46	49	62	59	54
Pendelton AP	42	46	63	59	53
Portland AP	46	49	60	57	53
Portland CO	48	50	61	59	55
Roseburg AP	47	49	60	57	53
Roseburg CO	48	51	61	59	55
Salem AP	46	49	60	57	53
Sexton Summit	42	44	55	52	48
Troutdale AP	45	48	59	57	52

MIL-HDBK-1003/8A

APPENDIX A (continued)

Location	Winter	Spring	Summer	Autumn	Annual
Pennsylvania					
Allentown AP	40	44	62	58	51
Erie AP	38	42	58	55	48
Erie CO	40	44	60	56	50
Harrisburg AP	43	47	63	59	53
Park Place CO	36	40	57	53	46
Philadelphia AP	44	48	64	61	54
Philadelphia CO	46	50	66	62	56
Pittsburgh Allegheny	42	46	62	58	52
Pittsburgh GRTR PITT	40	44	61	57	51
Pittsburgh CO	44	48	64	60	54
Reading CO	43	47	64	60	54
Scranton CO	40	44	61	57	50
Wilkes Barre-Scranton	39	43	60	56	49
Williamsport AP	40	44	61	57	51
Rhode Island					
Block Island AP	41	45	59	55	50
Providence AP	39	43	59	56	49
Providence CO	41	45	62	58	51
South Carolina					
Charleston AP	58	61	72	70	65
Charleston CO	60	62	74	71	67
Columbia AP	56	59	72	69	64
Columbia CO	57	60	72	69	64
Florence AP	55	59	72	69	64
Greenville AP	53	56	69	66	61
Spartanburg AP	53	56	70	66	61
South Dakota					
Huron AP	31	37	60	55	46
Rapid City AP	34	39	58	54	46
Sioux Falls AP	32	37	60	55	46
Tennessee					
Bristol AP	48	51	65	62	56
Chattanooga AP	51	55	69	65	60
Knoxville AP	50	54	68	65	59
Memphis AP	52	56	71	68	62
Memphis CO	53	57	72	68	62
Nashville AP	51	54	69	66	60
Oak Ridge CO	49	52	67	64	58
Oak Ridge 8 S	49	52	67	64	58

MIL-HDBK-1003/8A

APPENDIX A (continued)

Location	Winter	Spring	Summer	Autumn	Annual
Texas					
Abilene AP	55	58	73	70	64
Amarillo AP	47	50	67	63	57
Austin AP	60	63	76	73	68
Big Springs AP	56	59	74	70	65
Brownsville AP	68	70	79	77	74
Corpus Cristi AP	65	68	78	76	72
Dallas AP	57	61	76	72	66
Del Rio AP	62	65	77	75	70
El Paso AP	54	58	72	69	63
Fort Worth AP (Amon Carter)	57	60	75	72	66
Galveston AP	63	66	77	74	70
Galveston CO	63	66	77	74	70
Houston AP	62	65	76	73	69
Houston CO	63	66	77	74	70
Laredo AP	67	70	81	79	74
Lubbock AP	50	54	69	65	59
Midland AP	55	59	73	70	64
Palestine CO	58	62	74	71	66
Port Arthur AP	61	64	75	72	68
Port Arthur CO	63	65	76	74	69
San Angelo AP	58	61	74	71	66
San Antonio AP	61	64	77	74	69
Victoria AP	64	67	78	76	71
Waco AP	58	62	76	73	67
Wichita Falls AP	53	57	73	69	63
Utah					
Blanding CO	39	43	60	56	50
Milford AP	37	42	61	56	49
Salt Lake City AP	40	44	63	59	51
Salt Lake City CO	41	46	65	60	53
Vermont					
Burlington AP	32	37	57	52	44
Virginia					
Cape Henry CO	51	55	68	65	60
Lynchburg AP	48	51	66	62	57
Norfolk AP	51	54	68	64	59
Norfolk CO	52	56	69	66	61

MIL-HDBK-1003/8A

APPENDIX A (continued)

Location	Winter	Spring	Summer	Autumn	Annual
Richmond AP	48	52	67	63	58
Richmond CO	50	53	68	64	59
Roanoke AP	48	51	66	62	57
Washington					
Ellensburg AP	37	41	59	55	48
Kelso AP	45	47	57	54	51
North Head L H RESVN	47	49	54	53	51
Olympia AP	44	46	56	54	50
Omak 2 mi N W	36	40	59	55	47
Port Angeles AP	45	46	53	52	49
Seattle AP (Boeing Field)	46	48	58	56	52
Seattle CO	47	50	59	57	53
Seattle-Tacoma AP	44	47	57	55	51
Spokane AP	37	41	58	54	47
Stampede Pass	32	35	48	45	40
Tacoma CO	46	48	58	55	52
Tattosh Island CO	46	47	52	51	49
Walla Walla CO	44	48	65	61	54
Yakima AP	40	44	61	57	50
West Virginia					
Charleston AP	47	50	65	61	56
Elkins AP	41	45	59	56	50
Huntington CO	48	52	67	63	57
Parkersburg CO	45	49	65	61	55
Petersburg CO	44	48	63	60	54
Wisconsin					
Green Bay AP	31	36	56	51	44
La Crosse AP	32	38	60	55	46
Madison AP	34	39	59	54	47
Madison CO	34	39	60	55	47
Milwaukee AP	35	40	58	54	47
Milwaukee CO	36	41	59	55	48
Wyoming					
Casper AP	34	38	57	52	45
Cheyenne AP	35	39	55	51	45
Lander AP	31	35	56	51	43
Rock Springs AP	31	35	54	50	42
Sheridan AP	33	37	56	52	44

MIL-HDBK-1003/8A
Change 2, 30 December 1991

APPENDIX A (continued)

Location	Winter	Spring	Summer	Autumn	Annual
Hawaii					
Hilo AP	72	72	74	74	73
Honolulu AP	74	75	77	77	76
Honolulu CO	74	74	77	76	75
Lihue AP	72	73	76	75	74
Alaska					
Anchorage PA	25	29	46	42	35
Annette AP	40	42	51	49	46
Barrow AP	4	7	16	14	10
Bethel AP	18	23	41	37	30
Cold Bay AP	33	35	43	41	38
Cordova AP	32	35	45	43	39
Fairbanks AP	14	19	38	34	26
Galena AP	13	18	37	33	25
Gambell AP	15	19	34	30	24
Juneau AP	34	36	47	45	41
Juneau CO	36	39	49	46	42
King Salmon AP	25	28	44	40	34
Kotzebue AP	10	14	31	27	21
McGrath AP	14	18	37	33	25
Nome AP	16	20	37	33	26
Northway AP	12	16	32	29	22
Saint Paul Island AP	31	32	40	38	35
Yakutat AP	33	36	45	43	39
West Indies					
Ponce Santa Isabel AP	75	76	78	78	77
San Juan AP	77	77	79	79	78
San Juan CO	77	77	79	79	78
Swan Island	80	80	82	81	81
Virgin Islands					
St. Croix, V.I. AP	78	78	81	80	79
Pacific Islands					
Canton Island AP	83	84	84	84	84
Koror	81	81	81	81	81
Ponape Island AP	81	81	81	81	81
Truk Moen Island	81	81	81	81	81
Wake Island AP	79	79	81	81	80
Yap	81	81	82	82	82

MIL-HDBK-1003/8A
Change 2, 30 December 1991

REFERENCES

NOTE: THE FOLLOWING REFERENCED DOCUMENTS FORM A PART OF THIS HANDBOOK TO THE EXTENT SPECIFIED HEREIN. USERS OF THIS HANDBOOK SHOULD REFER TO THE LATEST REVISIONS OF CITED DOCUMENTS UNLESS OTHERWISE DIRECTED.

FEDERAL/MILITARY SPECIFICATIONS, STANDARDS, BULLETINS, HANDBOOKS, AND NAVFAC GUIDE SPECIFICATIONS:

Unless otherwise indicated, copies are available from Standardization Documents Order Desk, Building 4 D, 700 Robbins Avenue, Philadelphia, PA 19111-5094.

SPECIFICATIONS

MILITARY

MIL-P-28584A	Pipe and Pipe Fittings, Glass Fiber Reinforced Plastic for Condensate Return Lines
--------------	--

HANDBOOKS

MIL-HDBK-1002/2	Loads
MIL-HDBK-1003/6	Central Heating Plants
MIL-HDBK-1025/2	Dockside Utilities for Ships Service

NAVFAC GUIDE SPECIFICATIONS

NFGS-02685	Exterior Fuel Distribution System
NFGS-02685	Gas Distribution System
NFGS-02693	Exterior Shallow Trench Heat Distribution System
NFGS-02694	Exterior Underground Heat Distribution System
NFGS-02695	Exterior Aboveground Steam Distribution System
NFGS-02696	Exterior Piping Insulation
NFGS-02697	Exterior Buried Pumped Condensate Return System
NFGS-02698	Exterior Buried Preinsulated Water Piping

MIL-HDBK-1003/8A
Change 2, 30 December 1991

NFGS-09809	Protection of Buried Steel Piping and Steel Bulkhead Tie Rods
NFGS-15250	Insulation of Mechanical Systems

NAVY MANUALS, DRAWINGS, P-PUBLICATIONS, AND MAINTENANCE OPERATING MANUALS: Available from Commanding Officer, Naval Publications and Forms Center (NPFC), 5801 Tabor Avenue, Philadelphia, PA 19120-5099. To order these documents: government agencies must use the Military Standard Requisitioning and Issue Procedure (MILSTRIP); the private sector must write to NPFC, ATTENTION: Cash Sales, Code 1051, 5801 Tabor Avenue, Philadelphia, PA 19120-5099.

DESIGN MANUALS

DM-1.01	Basic Architectural Requirements
DM-3.01	Plumbing Systems
DM-3.03	Heating, Ventilating, Air Conditioning and Dehumidifying Systems
DM-3.5	Compressed Air and Vacuum Systems
DM-3.6	Central Heating Systems (See MIL-HDBK-1003/6 Reference)
DM-7.01	Soil Mechanics
P-272 (Part I)	Definitive Designs for Naval Shore Facilities
P-442	Economic Analysis Handbook

OTHER GOVERNMENT DOCUMENTS AND PUBLICATIONS:

NATIONAL INSTITUTE OF SCIENCE AND TECHNOLOGY (NIST)

NBS Handbook 135	Life-Cycle Cost Manual for the Federal Energy Management Program
------------------	--

Unless otherwise indicated, copies are available from National Technical Information Service (NTIS), Springfield, VA 22161.

NAVAL CIVIL ENGINEERING LABORATORY

NCEL UG-0005	Steam Trap Users Guide
--------------	------------------------

Available from Commanding Officer, Code L08B, Naval Civil Engineering Laboratory, Port Hueneme, CA 93043-5003.

MIL-HDBK-1003/8A
Change 2, 30 December 1991

NON-GOVERNMENT PUBLICATIONS:

Crocker and King, Piping Handbook, 5th Edition, available from McGraw-Hill Book Company, Inc., New York, NY 10036.

Keenan, Keyes, Hill and Moore, Thermodynamic Properties of Steam, available from J. Wiley & Sons, NY, Copyright 1969, Library of Congress Catalog, Card No. 68-54568.

AMERICAN SOCIETY OF MECHANICAL ENGINEERS (ASME)

ASME B31.1 Power Piping (ANSI/ASME)

ASME B31.8 Gas Transmission and Distribution Piping
Systems (ASME/ANSI)

Unless otherwise indicated, copies are available from American Society of Mechanical Engineers, 345 East 47th Street, New York, NY 10007.

AMERICAN SOCIETY OF HEATING, REFRIGERATING, AND AIR CONDITIONING ENGINEERS (ASHRAE)

ASHRAE Handbook - Fundamentals

ASHRAE Handbook - Systems

ASHRAE Handbook - Applications

ASHRAE Transactions Earth Temperature and Thermal Diffusivity at
Volume 71, Part 1, Selected Stations in the United States
p. 61, 1965)

Unless otherwise indicated, copies are available from American Society of Heating, Refrigerating, and Air Conditioning Engineers, Inc., 1791 Tullie Circle, N.E., Atlanta, GA 30329.

HYDRAULIC INSTITUTE (HI)

Pipe Friction Handbook

Unless otherwise indicated, copies are available from Hydraulic Institute, 712 Lakewood Center North, 14600 Detroit Avenue, Cleveland, OH 44107.

NATIONAL FIRE PROTECTION ASSOCIATION (NFPA)

NFPA 54 National Fuel Gas Code

Unless otherwise indicated, copies are available from National Fire Protection Association, Batterymarch Park, Quincy, MA 02269.

MIL-HDBK-1003/8A
Change 2, 30 December 1991

CUSTODIAN:
NAVY - YD

PREPARING ACTIVITY
NAVY - YD

PROJECT NO.
FACR - 0490

*U.S. GOVERNMENT PRINTING OFFICE: 1990--704-034/30889