

# UNIFIED FACILITIES CRITERIA (UFC)

## **CORROSION CONTROL AND PAINT FINISHING HANGARS**



APPROVED FOR PUBLIC RELEASE; DISTRIBUTION UNLIMITED

## UNIFIED FACILITIES CRITERIA (UFC)

### CORROSION CONTROL AND PAINT FINISHING HANGARS

Any copyrighted material included in this UFC is identified at its point of use. Use of the copyrighted material apart from this UFC must have the permission of the copyright holder.

U.S. ARMY CORPS OF ENGINEERS

NAVAL FACILITIES ENGINEERING COMMAND (Preparing Activity)

AIR FORCE CIVIL ENGINEER SUPPORT AGENCY

Record of Changes (changes are indicated by \2\ ... /2/)

Change No.	Date	Location
1	25 May 2005	Paragraph 2-5.3
2	1 March 2007	Added chapter 4.
<u>3</u>	<u>12 April 2007</u>	<u>Deleted Change 2 addition to paragraph 1-1.</u>
<u>4</u>	<u>1 April 2010</u>	<u>Added Air Force requirements, updated lighting requirement, added clean room requirement; changed document number from 4-211-02N to 4-211-02NF</u>

## FOREWORD

The Unified Facilities Criteria (UFC) system is prescribed by MIL-STD 3007 and provides planning, design, construction, sustainment, restoration, and modernization criteria, and applies to the Military Departments, the Defense Agencies, and the DoD Field Activities in accordance with [USD\(AT&L\) Memorandum](#) dated 29 May 2002. UFC will be used for all DoD projects and work for other customers where appropriate. All construction outside of the United States is also governed by Status of Forces Agreements (SOFA), Host Nation Funded Construction Agreements (HNFA), and in some instances, Bilateral Infrastructure Agreements (BIA.) Therefore, the acquisition team must ensure compliance with the more stringent of the UFC, the SOFA, the HNFA, and the BIA, as applicable.

UFC are living documents and will be periodically reviewed, updated, and made available to users as part of the Services' responsibility for providing technical criteria for military construction. Headquarters, U.S. Army Corps of Engineers (HQUSACE), Naval Facilities Engineering Command (NAVFAC), and Air Force Civil Engineer Support Agency (AFCEA) are responsible for administration of the UFC system. Defense agencies should contact the preparing service for document interpretation and improvements. Technical content of UFC is the responsibility of the cognizant DoD working group. Recommended changes with supporting rationale should be sent to the respective service proponent office by the following electronic form: [Criteria Change Request \(CCR\)](#). The form is also accessible from the Internet sites listed below.

UFC are effective upon issuance and are distributed only in electronic media from the following source:

- Whole Building Design Guide web site <http://dod.wbdg.org/>.

Hard copies of UFC printed from electronic media should be checked against the current electronic version prior to use to ensure that they are current.

### AUTHORIZED BY:

  
DONALD L. BASHAM, P.E.  
Chief, Engineering and Construction  
U.S. Army Corps of Engineers

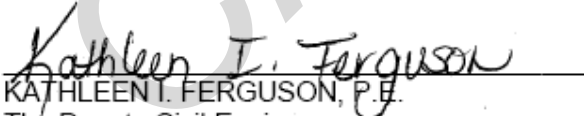
  
KATHLEEN I. FERGUSON, P.E.  
The Deputy Civil Engineer  
DCS/Installations & Logistics  
Department of the Air Force

  
DR. JAMES W. WRIGHT, P.E.  
Chief Engineer  
Naval Facilities Engineering Command

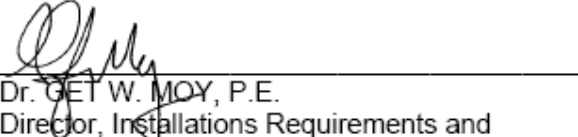
  
Dr. GET W. MOY, P.E.  
Director, Installations Requirements and  
Management  
Office of the Deputy Under Secretary of Defense  
(Installations and Environment)

**UNIFIED FACILITIES CRITERIA (UFC)  
REVISION SUMMARY SHEET**

**Document:** UFC 4-211-02NF

**Superseding:** UFC 4-211-02N

**Description of Changes:** Air Force requirements, based on Air Force Corrosion Control Facility Reference Guide, Change 7, November 2008, were integrated. Updated lighting requirements and added clean room requirement. All references were also updated to reflect the current document (usually UFC vice DM or MIL-HDBK) that contains the required referenced material.

**Reasons for Changes:**

Establish minimum design requirement for Air Force Facilities.

**Impact:** Recommendations from the Air Force Reference Guide are now mandatory. Corrosion Control Facility functionality is improved by updating lighting and adding clean room requirements.

CANCELLED

TABLE OF CONTENTS

CHAPTER 1 - INTRODUCTION .....	1
1-1 SCOPE.....	1
1-2 OTHER DESIGN CONSIDERATIONS.....	1
1-3 DEFINITIVE DRAWINGS.....	1
1-5 ORGANIZATIONAL COMMUNICATION.....	1
1-6 ENERGY CONSERVATION.....	1
1-7 ENVIRONMENTAL CONCERNS.....	2
1-8 ANTITERRORISM AND FORCE PROTECTION.....	2
1-9 BUILDING PROTECTION.....	2
1-10 FIRE PROTECTION.....	2
CHAPTER 2 - CORROSION CONTROL HANGARS.....	3
2-1 FUNCTION.....	3
2-2 LOCATION.....	3
2-3 ARCHITECTURAL AND STRUCTURAL REQUIREMENTS.....	4
2-3.1 Structure.....	9
2-3.2 Walls.....	9
2-3.3 Roofs.....	9
2-3.4 Floors.....	9
2-3.5 Ceilings.....	10
2-3.6 Doors and Door Controls.....	10
2-3.7 Building Insulation.....	10
2-3.8 Surface Treatment.....	11
2-3.9 Exterior Pavement.....	11
2-4 MECHANICAL REQUIREMENTS.....	11
2-4.1 Heating and Air Conditioning.....	11
2-4.2 Ventilation for Control of Air Contaminants and Flammable Vapors.....	12
2-4.3 Plumbing.....	14
2-4.4 Compressed Air.....	15
2-4.5 Noise and Vibration Control.....	16
2-5 ELECTRICAL REQUIREMENTS.....	16
2-5.1 Electrical Installations.....	16
2-5.2 Lighting.....	17
2-5.3 Grounding.....	17
2-6 WEIGHT-HANDLING EQUIPMENT.....	17
2-7 FIRE PROTECTION.....	17
2-8 ENVIRONMENTAL.....	18
2-8.1 Floor Drains and Waste Disposal System.....	18
2-8.2 \2\ Air Emissions.....	18
2-9 \4\ FALL PROTECTION.....	18
CHAPTER 3 - PAINT FINISHING HANGAR.....	20
3-1 FUNCTION.....	20
3-2 LOCATION.....	20

3-3	<b>ARRANGEMENT</b> .....	20
3-4	<b>ARCHITECTURAL AND STRUCTURAL REQUIREMENTS</b> .....	20
3-4.1	Structure.....	21
3-4.2	Roofs.....	21
3-4.3	Walls.....	21
3-4.4	Floors.....	21
3-4.5	Ceilings.....	21
3-4.6	Doors and Door Controls.....	21
3-4.7	Building Insulation.....	21
3-4.8	Surface Treatment.....	21
3-4.9	Exterior Pavement.....	22
3-5	<b>MECHANICAL REQUIREMENTS</b> .....	22
3-5.1	Heating.....	22
3-5.2	Ventilation for Control of Air Contaminants and Flammable Vapors.....	22
3-5.3	Air Conditioning.....	22
3-5.4	Plumbing.....	22
3-5.5	Compressed Air.....	22
3-5.6	Noise and Vibration Control.....	22
3-6	<b>ELECTRICAL REQUIREMENTS</b> .....	23
3-7	<b>FIRE PROTECTION</b> .....	23
3-8	<b>ENVIRONMENTAL CONTROLS</b> .....	23
3-9	<b>FALL PROTECTION</b> .....	23
4	<b>CHAPTER 4 - PLASTIC MEDIA BLAST HANGAR</b> .....	24
4-1	<b>FUNCTION</b> .....	24
4-1.1	PMB Material.....	24
4-1.2	PMB Recycling.....	24
4-1.3	PMB Hangar Cautions.....	25
4-2	<b>LOCATION</b> .....	25
4-3	<b>ARRANGEMENT</b> .....	26
4-4	<b>ARCHITECTURAL AND STRUCTURAL REQUIREMENTS</b> .....	26
4-4.1	Structure.....	26
4-4.2	Roofs.....	26
4-4.3	Walls.....	26
4-4.4	Floors.....	26
4-4.5	Ceilings.....	27
4-4.6	Doors and Door Controls.....	27
4-4.7	Building Insulation.....	27
4-4.8	Surface Treatment.....	27
4-4.9	Exterior Pavement.....	27
4-4.10	Use Group Classifications.....	27
4-4.11	Housekeeping.....	27
4-4.12	Other Architectural Requirements.....	27
4-5	<b>MECHANICAL REQUIREMENTS</b> .....	28
4-5.1	Heating.....	28
4-5.2	Ventilation for Control of Air Contaminants.....	28

4-5.3	<b>Air Conditioning</b> .....	29
4-5.4	<b>Plumbing</b> .....	29
4-5.5	<b>Compressed Air</b> .....	29
4-5.6	<b>Noise and Vibration Control</b> .....	29
4-5.7	<b>PMB Reclamation</b> .....	29
4-6	<b>ELECTRICAL REQUIREMENTS</b> .....	30
4-6.1	<b>Hazardous Classification</b> .....	30
4-6.2	<b>Grounding</b> .....	30
4-7	<b>FIRE PROTECTION</b> .....	30
4-8	<b>ENVIRONMENTAL CONTROLS</b> .....	30
4-9	<b>FALL PROTECTION</b> .....	31
	<b>GLOSSARY</b> .....	32
	<b>APPENDIX A - REFERENCES</b> .....	33
	<b>APPENDIX B - OSHA INTERPRETATIONS AND REFERENCES FOR REDUCED AIRFLOW AND RECIRCULATING AIRFLOW</b> .....	37
	<b>APPENDIX C - BUILDING TEMPLATES</b> .....	50

CANCELLED

## CHAPTER 1 - INTRODUCTION

### 1-1 SCOPE.

This UFC contains specific criteria for the design of Navy and Marine Corps aircraft corrosion control and paint hangars. \3\ (Change 2 was deleted.) /3/ Criteria for the design on maintenance hangars is contained in [UFC 4-211-01N](#), *Aircraft Maintenance Hangars: Type I, Type II and Type III* and this UFC is based on the basic design criteria it contains.

\4\ The requirements contained in this UFC apply to both Navy and Air Force facilities unless specifically noted. /4/

### 1-2 OTHER DESIGN CONSIDERATIONS.

Consult aircraft maintenance officers of shore activities throughout the design effort. This ensures that technical requirements for specific aircraft maintenance and testing procedures receive proper consideration. The facility must comply with all requirements of [UFC 1-200-01](#), *General Building Requirements*.

### 1-3 DEFINITIVE DRAWINGS.

Contact \4\ NAVFAC Atlantic Engineer Criteria and Programs Office /4/ for availability of definitive design drawings. \2\ Drawings contained in appendix E should be used for general guidance only and shall not overrule local facility requirements for items such as maintenance and space requirements. /2/

### 1-4 PLANNING.

\4\ Consult [UFC 2-000-05N \(P-80\)](#) *Facility Planning Criteria for Navy and Marine Corps Shore Installations* and [MIL-HDBK-1190](#), *Facility Planning*.

\4\ For Air Force projects use [AFH 32-1084](#), *Facility Requirements* and [UFC 3-260-01](#), *Airfield and Heliport Planning and Design* /4/.

### 1-5 ORGANIZATIONAL COMMUNICATION.

Provide an intercommunicating two-way voice system, with use restricted to maintenance and material management (3M.) Connect the system to the AIMD officer, assistant officer and production control office; with each squadron hangar; and the production control offices in the airframes shop, avionics shop, engine maintenance shop, ground support equipment shop, aviation armaments shop and aviation life support systems shop.

### 1-6 ENERGY CONSERVATION.



Energy conservation is a major consideration in the design of building envelopes, mechanical systems, and electrical systems. Refer to [UFC 3-400-01](#), *Energy Conservation*.

**1-7 ENVIRONMENTAL CONCERNS.**

The facility must comply with all applicable environmental regulations. /2/ The Whole Building Design Guide web site (<http://www.wbdg.org/>) provides information and links to the various laws and guidance documents pertaining to the environment. For site-specific information, contact the base environmental office and the local Facility Engineering Command.

**1-8 ANTITERRORISM AND FORCE PROTECTION.**

The facility must meet all applicable requirements of [UFC 4-010-01](#), *DoD Minimum Antiterrorism Standards for Buildings*. If a conflict occurs between this UFC and UFC 4-010-01, UFC 4-010-01 governs.

**1-9 BUILDING PROTECTION.**

Protect the facility, including corners of interior partitions and exterior walls, doors, and structural members, from damage by vehicles and moving loads. Install concrete-filled pipe guards, bumpers, railings, corner guards and similar protective features.

**1-10 FIRE PROTECTION.**

Provide fire protection in accordance with [UFC 3-600-01](#), *Fire Protection Engineering for Facilities* and \4\ [UFC 4-211-01N](#) /4/. \2\ Also refer to [NFPA 410](#), *Standard on Aircraft Maintenance*, particularly Chapter 7, "Aircraft External Cleaning, Painting and Paint Removal" and Chapter 10, "Fire Protection;" [NFPA 33](#), *Standard for Spray Application Using Flammable and Combustible Materials*; [NFPA 70](#), *National Electric Code*, especially Article 513, "Aircraft Hangars" and Article 516, "Spray Application, Dipping, and Coating Processes." /2/

\4\ For Air Force Projects, follow [UFC 3-600-01](#), *Fire Protection Engineering for Facilities* and [ETL 02-15](#), *Fire Protection Criteria - New Aircraft Facilities* and [ETL 98-8](#), *Fire Protection Criteria - Existing Aircraft Facilities*. /4/

## CHAPTER 2 - CORROSION CONTROL HANGARS

### 2-1 FUNCTION.

Design the corrosion control hangar to provide space and equipment for the corrosion control processing of aircraft. This corrosion control process can be performed at either a depot level or organizational and intermediate (O/I) level facility as defined in NAVAIR Technical Manual NA01-1A-509, *Aircraft Weapons Systems Cleaning and Corrosion Control*. Base facilities designed for depot level maintenance on de-paint/re-paint of the entire aircraft. Base facilities designed for O/I level maintenance on repair of damaged paint systems and de-paint/repaint of components only. This does not include de-painting by plastic media blasting (PMB) equipment. Functions performed in the corrosion control hangar include:

- a. deicing,
- b. limited detergent washing and rinsing,
- c. paint stripping,
- d. corrosion removal,
- e. protective coating application and painting, and
- f. finish curing and drying.

Refer to NAVAIR Technical Manual NA01-1A-509 for detailed functions performed in this facility.

4\ For Air Force Facilities, the minimum facility requirements to support unit/base level corrosion control functions are an environmentally controlled area to wash aircraft and hangar space for corrosion treating, corrosion repairing, paint stripping and performing maintenance painting on entire aircraft. Space must also be provided for the Corrosion Control Shop, which includes a preparation and paint application area for aircraft components and support equipment; paint mixing area; tool and equipment storage; paint storage; personnel hygiene facilities and administrative areas. /4/

### 2-2 LOCATION.

Locate the corrosion control hangar in proximity to the maintenance hangars and as close as possible to an aircraft washrack. Access between the corrosion control hangar, the maintenance hangar, and the aircraft washrack is required. Consider the prevailing wind in orienting the building in relation to aprons, taxiways, and parking, to avoid exhaust air dispersal over areas affected by solvent fumes 4\and to avoid recirculation into the ventilation system intakes./4/

Care must also be taken to site the hangar in accordance with the requirements of [NAVFAC P-80.3](#) and [UFC 3-260-01](#), *Airfield and Heliport Planning and Design*. It should not be sited within any runway safety zone or in a location where it might extend into any imaginary surface.

## 2-3            **ARCHITECTURAL AND STRUCTURAL REQUIREMENTS.**

4\ For Navy Projects,4/ there are two types of depot level corrosion control hangars.

- a. Type A corrosion control hangars are designed for carrier aircraft and other small aircraft.
- b. Type B corrosion control hangars are designed for land-based transport or patrol aircraft.

Because both construction and operating costs increase as the volume of the hangar bay increases, design depot level corrosion control hangars for aircraft larger than those accommodated by the Type B hangar and O/I level corrosion control hangars around the specific dimensions of the aircraft concerned. Aircraft dimensions can be found using the Aircraft Characteristics Database at <http://www.uscost.net/aircraftcharacteristics>.

With the exception of the following special requirements, design the corrosion control hangar using the general architectural and structural requirements for maintenance hangars set forth in [UFC 4-211-01N](#).

- The size of the various aircraft scheduled to use the facility will determine the hangar bay dimensions. Size the bay to accommodate fixed-wing aircraft with wings unfolded, and helicopters and V-22 with rotors in place and unfolded unless it has been determined that aircraft surfaces are accessible with the wings/rotors folded. The following minimum clearances are required to allow proper access for work platforms and to minimize paint overspray on hangar walls and ceilings:
  - (1) Top of aircraft (vertical fin, radome, rotor head, tail rotor) to underside of ceiling - 1.6 m (5 ft);
  - (2) Nose of aircraft to hangar door - 3.1 m (10 ft);
  - (3) Tail of aircraft or tail rotor to exhaust target wall - 3.1 m (10 ft);  
and
  - (4) Horizontal and vertical clearance from aircraft to open front door - 1.6 m (5 ft). In addition to these clearances, the depth of the door

and exhaust plenum (T) is required to properly size the hangar bay. The equation  $T = 1/5H$  defines this depth where H is the height of the aircraft at its highest point plus 1.6 m (5 ft). Note that the depth (T) does not include the thickness of the structure of the door or the filter media.

- Base the number of hangar bays for each site on an analysis of aircraft types, production schedules, hours required for each corrosion control operation, and number of work shifts. Refer to \4\ [UFC 2-000-05N](#) /4/ for criteria to develop the required quantity of bays. If the workload includes a mix of large and small aircraft, a moveable partition at the center of the bay can be used. Bays in which stripping, blasting, or grinding are done will be separate from spaces where painting is done.

\4\ For Air Force projects, determine the interior dimensions of the Corrosion Control facility, by using the dimensions of the largest aircraft that will occupy the facility plus an additional 3m (10 ft) on each side of aircraft to facilitate maintenance stands, etc. Do not overlook tail heights, the height and width of door, openings, structural protuberances in facilities, and the turn radius of tow vehicles connected to aircraft. The chart listed below was derived from information in [AFH 32-1084](#) and provides a means to determine minimum interior dimension requirements for an aircraft corrosion control hangar.

Aircraft Separation Dimensions Inside Hangars:

Minimum Clearances from Hangar Elements <sup>1</sup>						
Aircraft Element	Door		Walls		Roof Framing	
	m	ft	m	ft	m	ft
Wing Tip- under 30.5m (100 ft) span	3	10	3	10	-	-
Fuselage - under 30.5 m (100 ft) span	3	10	3	10	3	10
Wing Tip- over 30.5m (100 ft) span	3	10	4.6	15	-	-
Fuselage - over 30.5 m (100 ft) span	3	10	4.6	15	3	10
Tail - Vertical	2.1	7	-	-	3	10
Tail - Horizontal	3	10	3	10	3	10
Helicopter Rotor Blade	3	10	3	10	3	10

1. Clearances between aircraft components should be at least 3 m (10 ft) where two or more aircraft are housed. Where these clearances cannot be provided, an airfield waiver in accordance Appendix B, Section 13 of [UFC 3-260-01](#) is required.

2. See note 4 regarding depth of door from above/4/

General Architectural Requirements:

- Ancillary space requirements will vary based on facility requirements. Provide spaces for paint mixing, paint storage, waste paint area, bead blast rooms, gear equipment and tools, office, nondestructive inspection, strip/rinse, paint spray, and dry storage. Base the size of the rooms on the workload. Provide exit doors to the outside for rooms designated for storing or mixing chemicals or paints. Provide a depressed floor slab or doorsills with ramps to contain spills. Separate spaces where stripping, blasting, or grinding are done from spaces where painting is done.
- Provide storage space for dry filters. Provide stairs for personnel and a roof mounted jib crane for materials transport to the roof.
- Provide a loading dock.

- Provide a trench drain at the doorway between the hangar bays and the ancillary spaces.
- Provide a connection to the station Industrial Waste Treatment System or to a collection tank from all drains. The corrosion control process generates large amounts of water that could potentially hold solid or liquid paint residue or other solvents and wastes.
- Provide space for work on composite helicopter rotor blades if applicable.
- An overhead bridge crane is not required in the hangar bays.
- Locate utilities on the side walls. Use of utility pits in hangar floors is prohibited.
- Design for the aircraft fully loaded with fuel.
- \4\ Shower Facilities:

Provide shower facilities for persons engaged in the application of paints, coatings or other operations where contaminants may be harmful. The shower area should be designed as “walk-through” allowing for the separation of clean and dirty environments.

Showers shall have hot and cold running water feeding a common discharge line.

Body soap or other cleaning agent convenient to the shower shall be provided along with individual clean towels.

- Change Rooms:

When employees are required to wear protective clothing, change rooms with storage facilities for street clothes and separate storage facilities for protective clothing shall be provided.

- Paint Mixing Rooms:

All dispensing or transfer of flammable liquids from containers, mixing of flammable liquids, and filling of containers, including paint guns and pressure pots must be done only in an approved spray booth or mixing room. A separate paint mixing room will significantly reduce the

amount of clutter in the paint booth. A properly designed and located paint mixing room will accommodate all equipment, cabinets, and tables associated with paint mixing and daily-use storage of paints and thinners, which otherwise, would be housed within the confines of the paint booth. Installing prefabricated mixing booth is a simple method to incorporate a separate mixing area into a new or existing facility.

The design requirements in Section 2 are generally applicable to paint mixing rooms. Additional requirements are listed below:

- a. The size of the mixing room shall not exceed 150 ft<sup>2</sup> (14m<sup>2</sup>).
- b. Must have continuous mechanical ventilation capable of providing not less than 1 cfm of air movement per ft<sup>2</sup> of floor area or 150 cfm, whichever is greater.
- c. Mixing rooms should be provided with a floor drain to make it possible to wash down spills. However, local installations must ensure that collection sumps are installed in the floor drain system and (or) that the wastewater treatment plant can process the spillage. If this is not the case, local installations must develop an alternate means of cleaning up the spillage.
- d. Agitators shall be driven by compressed air, water, low-pressure steam, or electricity. If powered by an electric motor it must meet all electrical codes and standards.

- **Flammable and Combustible Liquid Storage**

Storage of flammable or combustible storage, in cabinets, specially designed room within the facility or in a detached structure is required.

Design shall comply with [NFPA 30](#), [NFPA 80](#), and 29 CFR 1910.106. AFOSHSTD 91-17 also applies for Air Force Projects. /4/

**2-3.1 Structure.**

The hangar structure should be steel frame with open-web, steel-joist roof. The structure for areas adjacent to the hangar area should be load bearing, insulated, concrete-masonry unit construction with open-web, steel-joist roof. Equip the strip/rinse room with a 1,814 kg (2-ton) overhead monorail. Incorporate the requirements of [NFPA 33](#), *Standard for Spray Application Using Flammable or Combustible Materials* into the design.

**2-3.2 Walls.**

With the exception of the following criteria, walls should be in accordance with [UFC 4-211-01N](#):

- a. Exterior walls of the hangar area should be a steel frame and girts framing system with insulated preformed (corrugated) metal siding. Use insulated concrete masonry units for all other exterior walls.
- b. Separate the hangar area from paint mixing and storage rooms, chemical mixing room, cleaning gear and storage room, corridor, and toilet and locker areas, by 2-hour fire-rated walls.
- c. Separate hangar bays in multiple-bay structures by 3-hour fire-rated walls.
- d. Provide seals at doors, wall penetrations, and building joints in the hangar bays and ancillary spaces to ensure airtight performance to maintain pressure differentials and prevent contamination of the air in the hangar bay.

**2-3.3 Roofs.**

Roofs should meet the criteria defined in [UFC 4-211-01N](#).

**2-3.4 Floors.**

Floors should meet the following criteria:

- a. The hangar area floor should be designed in accordance with criteria in [UFC 3-260-02](#), *Pavement Design for Airfields*.
- b. Design other floors in accordance with [UFC 1-200-01](#). Install resilient tile or sheet floor coverings.
- c. For new construction, use of a thin epoxy white reflective floor coating is prohibited. Include a white dry shake floor hardener as



the topping on the floor slab in the hangar area. Refer to [UFC 4-211-01N](#) for new construction and maintenance policies.

### 2-3.5 Ceilings.

Aircraft bays and paint storage, mixing, and spray areas should have water-resistant gypsum ceilings. Provide a 1-hour fire-rated ceiling in paint bays. Provide suspended acoustical ceilings for corridors, toilets, locker rooms, and offices. Install suspended acoustical ceiling panels in shower areas with vinyl plastic surfaces. The strip/rinse room ceiling should be of corrosion-resistant, perforated metal.

### 2-3.6 Doors and Door Controls.

Provide doors and controls in accordance with [UFC 4-211-01N](#).

2-3.6.1 **Hangar Doors.** Hangar doors should be a specialized, insulated, hangar type with swinging leaves. These doors should serve as an insulated supply air plenum when closed. Provide perforated plates in the supply air plenum, one stationary and one adjustable, which allow for balancing to achieve laminar flow. Use 19 mm (3/4-inch) to 25 mm (1-inch) holes spaced to give approximately 50 percent free area. Plates are to be 18 gauge galvanized steel.  $\sqrt{2}$  is recommended but other arrangement may be used if the required calculations are performed or if alternative successful designs can be proven. Refer to [UFC 3-410-04N](#), *Industrial Ventilation* for other criteria. A Computational Fluid Dynamics study is also recommended to help determine proper airflow from whichever configuration is used. /2/ Each door leaf should be a motor-operated unit with a release mechanism, and provide the doors with a means of movement in the event of a power failure. Install adequate safety devices to prevent injury to personnel and damage to equipment due to moving door sections. Design thresholds to minimize dirt accumulation and ice buildup. See [UFC 4-211-01N](#).  $\sqrt{2}$  For larger sized aircraft, other types of doors may be considered. /2/

2-3.6.2 **Personnel Doors.** Install 1-1/2-hour B-rated, self-closing fire doors for personnel doors between the hangar area and paint and chemical mixing rooms and the corridor. Hold-open devices are not permitted.

2-3.6.3 **Other Doors.** Other doors should be as described in [UFC 4-211-01N](#). Provide self-closing, insulated personnel exit doors from each hangar bay. No hold-open devices are permitted. Take special precautions to seal doors between hangar areas and exterior or adjacent spaces. Provide a vehicle access door either within or adjacent to the hangar aircraft access doors.

### 2-3.7 Building Insulation.

Insulate building walls, roofs, and floors in accordance with [UFC 4-211-01N](#).

**2-3.8 Surface Treatment.**

Provide the sidewalls, the inside of hangar doors, and the ceiling of the hangar area with a light color, smooth surface such as white enameled metal panels.

**2-3.9 Exterior Pavement.**

Exterior paved areas include aircraft and vehicle access and non-organizational parking. Aircraft pavement should be in accordance with [UFC 3-260-02](#). Vehicle access and parking should be in accordance with facility plates in this UFC and [MIL-HDBK-1190](#), *Facility Planning and Design Guide*.

∨\ Orient hangar such that is complies with all geometric requirements of [UFC 3-260-01](#). /4/

**2-4 MECHANICAL REQUIREMENTS.**

The design of the corrosion control hangar should meet the mechanical requirement set forth in the following paragraphs.

**2-4.1 Heating and Air Conditioning.**

Provide heating and air-conditioning in accordance with [3-400-10N](#), *Mechanical Engineering (DRAFT)* and as follows:

2-4.1.1 Based on an economic analysis, consider providing a system for the recovery of heat from the exhaust air. ∨\ Heat recovery systems must not permit contaminated exhaust air from migrating into the supply air system. In particular, heat wheels are discouraged. Regardless of the type of system provided, a detailed, provide in-depth analysis to prove that the airflow introduced into the paint area is uniform in distribution and velocity, and that the system can be properly operated for building pressure requirements. Many systems do not perform as anticipated during the design process, due to lack of foresight of real world conditions, the influence of building structure, the air delivery system inlet and outlet conditions, the air exhaust system, the actual aircraft characteristics and surrounding scaffolding and access equipment, among other things. The analysis can be performed by scaled mockup, scaled wind tunnel analysis or Computational Fluid Dynamics (CFD) modeling, among others. The Navy has also specifically endorsed the use of CFD. Refer to OPNAVINST 4790.2. For more extensive information on CFD modeling refer to High Performance Computing Modernization Office (HPCMO), the National Institute for Occupational Safety and Health (NIOSH), the American Society of Heating, Refrigeration and Air Conditioning Engineers (ASHRAE), the American Society of Mechanical Engineers (ASME), the U.S. General Services Administration (GSA) and the U.S. Environmental protection Agency (EPA) for studies using CFD

analysis for industrial ventilation requirements. It is suggested to employ a third party consultant to perform these functions. /2/

2-4.1.2 The required hangar bay design heating temperature will normally be between 24 degrees C (70 degrees F) and 32 degrees C (90 degrees F) with a relative humidity between 50 and 70 percent. Some activities may require higher temperatures to accelerate curing cycles. Determine exact requirements for each site based on materials and production requirements. Equip hangar with an automatic cutoff of the heating system when the main hangar doors are open. Minimum temperature thermostat should be set at 1 degree C (34 degrees F) to override the heating deactivation switch during door-open periods of subfreezing ambient temperatures. The recovery time for the heating system should be 30 minutes after door closure.

2-4.1.3 Provide a snow-melting system at the hangar door tracks when the outside design temperature is -4 degrees C (+25 degrees F) or lower and when historical snow data supports the requirement.

2-4.1.4 Refer to the facility plates for design conditions in other hangar spaces.

2-4.1.5 Each bay in the OH area should be a separate heating zone.

2-4.1.6 Heating should be suitable for operation in the vapor hazard condition in the hangar bay, flammable storage/mixing areas and paint equipment cleaning spaces.

#### 2-4.2 **Ventilation for Control of Air Contaminants and Flammable Vapors.**

2-4.2.1 \2\ The goal of the facility is to provide a system that is energy efficient, cost effective to install, while ensuring proper requirements for operator health and safety are maintained. /2/

2-4.2.2 Provide ventilation in accordance with [UFC 3-410-04N](#), *Industrial Ventilation*, [NFPA 33](#), \2\ and [ANSI Z9.2, 4, and 7](#); refer to Appendix B for further guidance. /2/ The \4\ typical /4/ ventilation system for the hangar area should furnish 100 percent filtered outside air at a horizontal laminar flow velocity of \2\ 0.508 /2/ m/s (100 fpm) across the entire cross-section area of the hangar bays for chemical stripping/painting operations for worker safety and overspray control \2\ in accordance with OSHA. This velocity may be decreased in accordance with OSHA and its interpretations for consideration of paint spray areas vs. paint booths, depending on the size of aircraft and the exact type and amount of operations considered for the space. Recirculation of airflow may be evaluated according to requirements of [NFPA-33](#) and [ANSI Z-9.7](#). Refer to the extensive studies and information provided by the Air Force Research laboratory (AFRL) in

appendix B and other sections for more information. Refer to applicable OSHA interpretation in appendix D. /2/ Provide 0.25 m/s (50 fpm) airflow velocity during the drying cycle and de-paint by grinding operations, and a minimum of 6 air changes per hour for other procedures. \2\ Refer to [UFC-3 410-04](#) for fan requirements. /2/ Provide demister in the supply system.

2-4.2.3 \2\ The use of High Volume Low Pressure (HVLP) and HVLP electrostatic paint application techniques greatly reduces the amount of overspray exposure to workers, versus conventional air atomization air-assisted, air less, or electrostatic paint spray methods, and is recommended to reduce overspray and increase exhaust filter life. When HVLP and /or HVLP electrostatic paint techniques are used over spray is greatly reduced as well as potential health effects to the workers. Verify systems performance to ensure system is not over designed. /2/

\4\The minimum maintained air velocity required for hand held electrostatic paint spray operations as specified in [OSHA 1910.107](#) is 60 linear fpm. However, the requirements currently contained in [OSHA 1910.94 Table G-10](#) are somewhat more lenient and allows a range of 50-75 linear fpm. Due to the minor inconsistencies in these requirements, any unit planning to design a paint booth that will be used exclusively for electrostatic paint spraying should contact their local fire protection and bioenvironmental engineering functions for current guidance. The air volume requirements for paint booths in which fueled aircraft will be painted with electrostatic paint spray equipment are more stringent. In this situation, the ventilation shall be sufficient to limit vapor concentration to 500 ppm or 20 percent of the LEL, whichever is lower./4/

2-4.2.4 Interlock the fans and the compressors so that the compressors cannot operate when the fans are inoperative. Interlock the fans and the fire protection system so that the fans cannot operate when the fire protection system is inoperative. \4\The electrical equipment used in the electrostatic spraying process shall be interlocked with the ventilation spraying area so that the equipment cannot be operated unless the ventilation fans are in operation./4/\2\ Filter pressure, space pressure, fan status, breathing air system, critical component failure, etc. should be monitored by the building automated control system. All critical alarms, notifications and status points shall also be indicated on a control panel either within the hangar or at an operator monitoring station. \4\An audible alarm system, which activates in the event of a ventilation system failure shall be provided for the electrostatic spraying process./4/ Consider that /2/ ventilation system should \2\ possibly /2/ maintain a slightly positive static pressure of 1.25 mm (0.05 in.) water gage between the hangar area and the exterior to avoid infiltration of contaminants into the hangar space that can affect painting operations. However, some studies indicate that a slightly negative pressure in the area provides for more superior painting and reduces

turbulent flow in the areas that should be addressed. (Refer to *System-Level Computational Fluid Dynamics: Advanced CFD Tools to Solve Problems of Operational Conditions, States of Large-Scale Engineered and Natural Systems* for additional guidance.) /2/ Maintain a slightly higher pressure in the adjacent ancillary spaces and overhead ceiling spaces than in the hangar area to keep the hazardous fumes given off by stripping agents from infiltrating into these spaces. Ventilate the space above the hangar bay ceiling to provide a non-hazardous space for light fixtures.

\4\ A key requirement of the ventilation system is its ability to reduce the amount of hazardous air pollutants (HAPs) (e.g., chromium, cadmium, lead, etc.) that are released into the atmosphere. The National Emission Standards for Hazardous Air Pollutants for Source Categories: Aerospace Manufacturing and Rework Facilities (commonly called the Aerospace NESHAP) require that filters be installed in the ventilation system to control the inorganic HAP emissions before they are exhausted to the atmosphere. /4/ Filters throughout should be made from noncombustible materials and should meet approval of the fire protection authorities. Filters upstream of the supply fan and filters in the door plenum should have an efficiency of \2\ MERV 5 or better /2/ on the basis of \2\ ASHRAE 52.2, *Method of Testing General Ventilation Air-Cleaning Devices Used for Removal Efficiency by Particle Size*. Filters in the exhaust walls shall meet the requirements for the 3 part system per NESHAP. /2/ Determine the type of exhaust filter system by an analysis of environmental control regulations at the site \2\ for additional requirements. If air recirculation systems are considered, additional filtering may be required. Refer to the AFRL \4\ & [40 CFR 63.745](#) /4/ for further information. /2/

Install visual gauges, audible alarms, or pressure activated devices on filters to ensure that the air velocity is maintained. Provide exhaust ventilation from the floor level for the paint mixing and storage rooms. \2\ Refer to ACGIH IV manual VS-75-30. Also, paint mixing can be done on ventilated benches. Refer to [UFC 3-410-04N](#). /2/ Provide ventilation systems for paint mixing and paint equipment-cleaning rooms in accordance with [NFPA 33](#) and the [ACGIH Industrial Ventilation, A Manual of Recommended Practice](#). Consider heat recovery in the ventilation system for those spaces. Exhaust stacks should be the "no loss" type as shown in [ACGIH Industrial Ventilation, a Manual of Recommended Practice](#). \2\ Consider recirculation of airflow per NPFA-33 and ANSI Z9.7 and refer to Guidance found in the AFRL. See Appendix D for OSHA interpretations. /2/

#### 2-4.3 **Plumbing.**

Provide plumbing in accordance with [UFC 3-420-01](#), *Plumbing Systems* and as follows:

- a. Provide \4\ rest room and shower facilities, which are separate for each sex. Determine fixture counts in accordance with the "Factory

and Industrial” exception to Table 403.1 in [UFC 3-420-01](#). Each rest room should have direct access to appropriate lockers and showers. Revise [UFC 3-420-01](#) shower requirements to provide one shower for every ten (10) employees (or fraction thereof) for of each sex who are required to shower during the same shift. /4/

- b. Provide an emergency eyewash/safety shower conforming Appendix B of [UFC 3-420-01](#). Refer to paragraph 2-8 for discharge requirements.
- c. Provide an oil separator for drains from the hangar area and paint mixing rooms and paint equipment cleaning rooms.
- d. Locate storm-water drains at least 310 mm (12 in) from the hangar access door rails.
- e. Provide AFFF/sprinkler discharge collection/ retention system when required by environmental regulations. Provide a connection to the station Industrial Waste Treatment System or to a collection tank from all drains. The corrosion control process generates large amounts of water that could potentially hold solid or liquid paint residue or other solvents and wastes. \2\ Refer to [UFC 4-451-10N](#) *Design: Hazardous Waste Storage* and [UFC 4-832-01N](#), *Industrial and Oily Wastewater Control*. /2/

#### 2-4.4 **Compressed Air.**

Provide low-pressure air for operation of tools and for breathing air in accordance with the following criteria:

- a. Provide low-pressure compressed air at 40 percent to 60 percent humidity and at 862 kPa (125 psig) for shop use. Air should be oil-free to prevent paint contamination. Air outlets supplying tools requiring lubrication should be equipped with an in-line lubricator. Rotary oil-free compressors are recommended since this compressed air may be used as a source for breathing air at lower life cycle costs.
- b. Provide low-pressure compressed air at 138 kPa (20 psig) or higher if required, at 40 percent to 60 percent humidity for breathing air in the hangar bays. \4\The breathing air compressor must minimize moisture content so that the dew point is 5.56 degrees Celsius (10 degrees Fahrenheit) below the ambient temperature./4/ Breathing air shall be obtained from the oil-free shop air source through final purifiers in each bay or from a separate breathing air compressor and piping system \2\ that meets requirements by OSHA for



minimum Grade D air as described in [ANSI/CGA G-7.1-1989](#) Commodity Specification for Air. Breathing air from the oil-free shop air source is preferred because of lower cost.

- c. The air outlets (quick connect fittings) for oil-free shop air, lubricated tool air, and breathing air should be different for each service and should not be compatible with each other.
- d. Typical outlet quantities for each bay are: four breathing and four oil-free shop air and two lubricated tool air. Typically, two oil-free shop air outlets are required per ancillary space. Verify actual requirements for each site.
- e. Locate the intake for breathing air in an uncontaminated area. Air-line respirators approved with a vortex tube will substantially reduce the temperature of the air supplied to the respirator in cases where the supplied air is from a high temperature environment

#### **2-4.5 Noise and Vibration Control.**

Design mechanical systems and equipment to limit noise and vibration in accordance with [UFC 3-450-01](#), *Noise and Vibration Control*. Design hangar bay for maximum 75 dBA space average. Provide sound traps to attenuate fan noise down to this level. Noise levels of 55 dBA in the hangar bay area with the ventilation system operating at maximum airflow have been achieved with careful design attention to fan and duct noise characteristics. Outdoor noise levels should not exceed 75 dBA and should comply with local regulations.

#### **2-5 ELECTRICAL REQUIREMENTS.**

Provide electrical systems in accordance with [UFC 3-501-01](#), *Electrical Engineering* and as defined in [UFC 4-211-01N](#). Electrical equipment in the hangar bay should be waterproof when deluge sprinkler protection is provided to prevent equipment damage in the event of testing or accidental discharge of the deluge system.

##### **2-5.1 Electrical Installations.**

Electrical installations in the following areas should meet the requirements in [NFPA 70](#), *National Electrical Code* for the specific hazardous (classified) location:

- Hangar area,
- Paint and chemical mixing rooms,

- Paint equipment cleaning room,
- Paint storage room.

#### 2-5.2 **Lighting.**

\4\ Provide lighting in accordance with [UFC 3-530-01](#), *Design: Interior and Exterior Lighting and Controls* and also: /4/

- Avoid the use of explosion-proof overhead fixtures by providing sealed, ventilated space above the finished ceiling.
- Provide power outlet in the hangar bays for task lights

#### 2-5.3 **Grounding.**

\1\ Provide the maintenance hangar with flush mounted, floor power ground receptacles, each with a 19 mm (3/4-inch) diameter ground rod, located at a minimum of 7.3 m (24 foot) centers across the centerline of the OH space. Locate additional power ground receptacles around dedicated aircraft parking areas to facilitate the use of grounding connections. When aircraft are parked outside of the hangar, provide static ground receptacles on parking aprons. Resistance to ground for ground power must not exceed **10 ohms** maximum, and for static ground, must not exceed 10,000 ohms in accordance with [MIL-HDBK-274](#) (AS), *Electrical Grounding for Aircraft Safety* and with NAVSEA OP5, *Ammunition and Explosives Ashore Safety Regulations for Handling, Storing, Production, Renovation and Shipping*. Connect ground receptacles together with No. 1/0 AWG minimum bare copper below the hangar floor and connected to the facility grounding system. /1/

\4\ For Air Force Facilities see [UFC 3-260-01](#), Appendix B11 and [AFI 32-1065](#), *Grounding Systems*. /4/

#### 2-6 **WEIGHT-HANDLING EQUIPMENT.**

The monorail hoist should be in accordance with criteria in [UFC 3-320-07N](#), *Weight Handling Equipment* and should be of spark-proof construction with an explosion-proof motor. Controls should be operable from the floor level and, when electric, should meet the requirements indicated in paragraph 2-5.1.

#### 2-7 **FIRE PROTECTION.**

The fire protection design should be in accordance with paragraph 1-10. Provide the following features:

- a. In the hangar bays, requirements of [UFC 4-211-01N](#) should be met.



- b. Provide an automatic wet-pipe sprinkler system in ancillary spaces.
- c. Provide manual and automatic fire alarm system reporting to the base-wide system.

## 2-8 **ENVIRONMENTAL.**

\4\ The type of environmental controls required will depend on the pollution abatement regulations at the site and the type and quantities of paints used. Environmental controls can be a major construction and operating cost item; therefore, an accurate determination of regulations and paints (existing and proposed) is required prior to design /4/Design should be in accordance with environmental protection regulations and the requirements as follows:

### 2-8.1 **Floor Drains and Waste Disposal System.**

Design for accidental spill of paint strippers and thinners, paint, cleaning solvents, pretreatment chemicals, fuel, oil, aqueous film-forming foam (AFFF) etc. Provide for zero discharge from the facility unless the facility will discharge to an existing or new industrial waste treatment facility (IWTF) or to a municipal sewer system. In each case, the IWTF must be capable of handling both the type and volume of the chemicals that will be discharged. Consult the local Facilities Engineering Command Environmental Office for appropriate discharge standards. Provide above-grade containment of accidental spills with appropriate sumps for pumping and cleanup of spilled wastes. Size the containment capacity for the largest possible discharge. Provide a method to prevent the drains from clogging.

### 2-8.2 \2\ **Air Emissions.**

Emissions of volatile organic compounds (VOC), hazardous air pollutants (HAP) and particulates from surface coating facilities are regulated by USEPA and state environmental agencies via various air pollution regulations, including the National Emission Standard for Hazardous Air Pollutants (NESHAP) for Aerospace Manufacturing and Rework Facilities (40 CFR 63, Subpart GG). Consult the base environmental office and the cognizant Facilities Engineering Command for appropriate requirements for the site. Make every effort to achieve compliance with applicable regulations by use of compliant coatings or other pollution prevention alternatives vice the use of VOC/HAP emission controls. Consider recirculation of airflow per [NPFA-33](#) and [ANSI Z9.7](#). See appendix D for additional information for OSHA interpretations and the AFRL. Recirculation allows for pollution abatement sizing equipment reduction in those areas requiring engineering controls for attainment purposes. /2/

## 2-9 \4\ **FALL PROTECTION**

Provide fall protection when leveled worked platforms are not adequate to reach the upper surfaces of the aircraft. For larger aircraft, personnel often must walk on aircraft wings or other surfaces during corrosion operations and fall arrest or fall restraint systems are mandatory. Experience has shown that lifeline type systems, to which safety harnesses can be attached, are the most effective means of accessing upper surfaces.

For Navy projects see [UFC 4-211-01N](#). For Air Force Projects, see AFOSHSTD 91-100 , EM 385-1-1 Section 5 & Section 21, and AFOSHSTD 95-501. /4/

CANCELLED

## CHAPTER 3 - PAINT FINISHING HANGAR

### 3-1 FUNCTION.

\4\ A paint finishing hangar is a powered-ventilated structure provided to enclose or accommodate a spraying operation to confine and limit the escape of spray, vapor, and residue and to safely conduct or direct them to an exhaust system. [This definition applies equally to large aircraft corrosion control paint hangars or modular or "walk-in" booths used to paint removable aircraft components and support equipment. Therefore, all design requirements are also equally applicable.

There are numerous types and configurations of paint spray booths to consider. The most common types are water-wash and dry-spray. The most common configurations are cross draft; downdraft, and semi-downdraft. The advantages and disadvantages of each particular booth should be closely evaluated before a final decision is made.

Additional information for modular spray booths is available in the *Air Force Corrosion Control Facility Reference Guide*. /4/

\4\ For Navy facilities, /4/ design the paint-finishing hangar for use only as a part of a NADEP or a selected intermediate maintenance activity as determined by the major claimant and approved by the Shore Development Board for cleaning, painting, and curing aircraft surfaces using production line methods. Provide work-bays, storage, and administrative spaces.

### 3-2 LOCATION.

Locate the paint-finishing hangar with due regard to the requirement for aircraft and vehicle access. In orienting the building, consider the prevailing wind in relation to the intake and exhaust of large volumes of air for the ventilation system.

### 3-3 ARRANGEMENT.

Arrange work-bays so that each has ready access to the outside and to equipment and storage spaces of the hangar. Isolate work-bays in which cleaning and stripping are done from work-bays in which painting and curing are done. Administrative spaces such as work control offices may be accommodated in mezzanines. Provide mechanical equipment rooms with outside access.

### 3-4 ARCHITECTURAL AND STRUCTURAL REQUIREMENTS.

Design each hangar for the size and configuration of the specific aircraft to be handled. Determine work-bay dimensions, ceiling heights, and door openings by

the aircraft dimensions. Determine the number of work-bays by the workload. In addition to the following specific requirements, design the paint finishing hangar using the general architectural criteria for maintenance hangars, as set forth in [UFC 4-211-01N](#).

4\ See Section 2-3 for General Architectural Requirements. /4/

**3-4.1 Structure.**

Use noncombustible construction materials. Reinforced concrete slabs (with perimeter insulation) and columns with insulated masonry exterior walls are preferred. Refer to [UFC 1-200-01](#). Incorporate the requirements of [NFPA 33](#).

**3-4.2 Roofs.**

Design roof in accordance with [UFC 4-211-01N](#).

**3-4.3 Walls.**

Isolate work-bays and spaces used for paint and chemical mixing with 2-hour fire-rated walls.

**3-4.4 Floors.**

Design work-bay floors in accordance with the criteria in [UFC 3-260-02](#). Design other floors in accordance with [UFC 1-200-01](#).

**3-4.5 Ceilings.**

Provide administrative and personnel spaces with a noncombustible, suspended acoustical ceiling.

**3-4.6 Doors and Door Controls.**

Provide doors and controls in accordance with [UFC 4-211-01N](#).

**3-4.7 Building Insulation.**

Insulate building walls, roof, and floor in accordance with [UFC 4-211-01N](#).

**3-4.8 Surface Treatment.**

In addition to the requirements in paragraph 2-3.8, provide walls, inside surfaces of doors, and ceilings of work-bays with a light-colored, smooth, hard surface.

3-4.9 **Exterior Pavement.**

4) Orient hangar such that it complies with all geometric requirements of [UFC 3-260-01](#). /4/

Exterior paved areas of the hangar include aircraft and vehicle access and non-organizational parking. Aircraft pavement should be in accordance with [UFC 3-260-02](#), and vehicle access and parking should be in accordance with [MIL-HDBK-1190](#).

3-5 **MECHANICAL REQUIREMENTS.**

Design the paint-finishing hangar to meet the criteria set forth in [UFC 4-211-01N](#), with the following special requirements:

3-5.1 **Heating.**

Provide heating systems in accordance with paragraph 2-4.1.

3-5.2 **Ventilation for Control of Air Contaminants and Flammable Vapors.**

Provide ventilation systems in accordance with paragraph 2-4.2.

3-5.3 **Air Conditioning.**

Provide air conditioning systems for administrative areas in accordance with paragraph 2-4.1.

3-5.4 **Plumbing.**

Provide plumbing systems in accordance with paragraph 2-4.3. Provide an industrial waste system if required by facility pollution control procedures for control of paint stripping residue. Locate storm water drains at least 310 mm (12 in) from the hangar access door rails.

3-5.5 **Compressed Air.**

Provide compressed air in accordance with paragraph 2-4.4.

3-5.6 **Noise and Vibration Control.**

Design mechanical systems and equipment to limit noise and vibration in accordance with [UFC 3-450-01](#).

**3-6 ELECTRICAL REQUIREMENTS.**

Provide electrical systems, including power, lighting and grounding, in accordance with paragraph 2-5.

**3-7 FIRE PROTECTION.**

Design fire protection systems in accordance with paragraph 1-10.

**3-8 ENVIRONMENTAL CONTROLS.**

The type of environmental controls required will depend on the pollution abatement regulations at the site and the type and quantities of paints used. Environmental controls can be a major construction and operating cost item; therefore, an accurate determination of regulations and paints (existing and proposed) is required prior to design.

**3-9 \4\ FALL PROTECTION**

See Section 2-9. /4/

CANCELLED

## CHAPTER 4 - PLASTIC MEDIA BLAST HANGAR

### 4-1 FUNCTION.

The basic function of an abrasive blasting facility is to remove coatings and/or corrosion to prepare aircraft, aircraft components, ground equipment, or other types of equipment for surface coatings and corrosion treatment. Plastic Media Blasting (PMB) is the most common abrasive used during depot and field level abrasive blasting operations. Other types of abrasive materials are used so design the facility to accept other abrasives.

During blasting operations, abrasives and the surface coatings on the blasted materials are shattered to varying degrees. This generates dust, which may contain particles of respirable size (0 to 5 micrometer). The composition and toxicity of the dust is often a health or combustion hazard.

A blast cleaning room is an enclosed space where the worker operates the blasting nozzle inside with the component. An enclosure where the operator stands outside and operates the blasting nozzle through an opening or openings in the enclosure is a blasting cabinet and is generally considered equipment and is not to be included in this section. /4/

For Navy facilities /4/ design the plastic media blast (PMB) hangar for use only as a part of a NADEP or a selected intermediate maintenance activity as determined by the major claimant and approved by the Shore Development Board for cleaning, painting, and curing aircraft surfaces using production line methods. Provide work-bays, storage, and administrative spaces.

#### 4-1.1 PMB Material.

Data sheets for the Plastic Media blast (PMB) material indicate it is non-combustible at the particle size that the material will be initially used at (a PG-1 size which is 5% > 12 mesh, 12 mesh > 80% > 16 mesh and 16 mesh > 15% > 20 mesh). It is typical for many dusts that they are not combustible until they reach a particle size of 420 microns or less in diameter (i.e., material passing through a U.S. No. 40 Standard Sieve). The PMB material behaves in this manner, being combustible when particles are small enough; and thereby having the potential to generate a dust explosion when enough of these very small particles are in a uniform fine suspension in air and are heated to a high enough temperature.

#### 4-1.2 PMB Recycling.

In the PMB process for aircraft stripping functions the blast media is recycled when particles are between 12 and 60 mesh. As particle size becomes smaller (i.e. pass through a 60 mesh sieve) the particles become uneconomical for the

stripping process and these smaller particles are removed in the stages one and two of the media reclamation process. As particles between 12 and 60 mesh are recycled, some of the media that is returned to the stripping process falls in the particle size range that is combustible (i.e. that between 40 and 60 mesh).

4\ The following system elements are also required:

- a. Do not integrate the exhaust ventilation system with the media recovery system
- b. Protect the media recovery system and ductwork from moisture and rainwater intrusion to keep the media from caking and plugging up the system.
- c. Use a pneumatic recovery system instead of mechanical recovery system for plastic media. (Mechanical systems tend to abrade the media.)  
/4/

#### 4-1.3 **PMB Hangar Cautions.**

The premise of the building design is that the system interlocking, media recovery, media recycling and housekeeping policies in the facility shall be such to ensure that small dust particles are not allowed to accumulate anywhere in the hangar space. Thus the hangar bay space will not be classified a hazardous space despite the presence of PMB material, which under some circumstances is a combustible dust.

Designers should be aware that PMB materials in a laboratory setting have been shown to form dust clouds that can result in dust explosions. Research reports by US Bureau of Mines have concluded that:

- a. As delivered and normally used PMB material is not hazardous. This refers to material in the 12-16 Mesh size range when delivered, and 12-60 Mesh size range when recycled.
- b. Recycled media in range 12 to 80 mesh will not explode.
- c. In PMB where all material is very fine i.e. all below 140 Mesh, an explosion is likely in an explosive test chamber with a spark igniter.
- d. In PMB media where all material is fine i.e. all below 40 Mesh, an explosion is possible under some conditions in an explosive test chamber with a spark igniter.

#### 4-2 **LOCATION.**



Locate the paint-finishing hangar with due regard to the requirement for aircraft and vehicle access. In orienting the building, consider the prevailing wind in relation to the intake and exhaust of large volumes of air for the ventilation system.

**4-3 ARRANGEMENT.**

Arrange work-bays so that each has ready access to the outside and to equipment and storage spaces of the hangar. Isolate work-bays in which cleaning and stripping are done from work-bays in which painting and curing are done. Administrative spaces such as work control offices may be accommodated in mezzanines. Provide mechanical equipment rooms with outside access.

**4-4 ARCHITECTURAL AND STRUCTURAL REQUIREMENTS.**

Design each hangar for the size and configuration of the specific aircraft to be handled. Determine work-bay dimensions, ceiling heights, and door openings by the aircraft dimensions. Determine the number of work-bays by the workload. In addition to the following specific requirements, design the paint finishing hangar using the general architectural criteria for maintenance hangars, as set forth in [UFC 4-211-01N](#).

\\ See Section 2-3 for General Architectural Requirements. /4/

**4-4.1 Structure.**

Use noncombustible construction materials. Reinforced concrete slabs (with perimeter insulation) and columns with insulated masonry exterior walls are preferred. Refer to [UFC 1-200-01](#). Incorporate the requirements of [NFPA 33](#).

**4-4.2 Roofs.**

Design roof in accordance with [UFC 4-211-01N](#).

**4-4.3 Walls.**

Isolate work-bays and spaces used for paint and chemical mixing with 2-hour fire-rated walls. All interior surfaces of the hangar bay shall be smooth such that the accumulation of dust is not possible. Hangar bay walls and ceiling shall be sealed to prevent migration of dust into the cavity behind the wall or above the ceiling.

**4-4.4 Floors.**

Design work-bay floors in accordance with the criteria in [UFC 3-260-02](#). Design other floors in accordance with [UFC 1-200-01](#).

4-4.5 **Ceilings.**

Provide administrative and personnel spaces with a noncombustible, suspended acoustical ceiling.

4-4.6 **Doors and Door Controls.**

Provide doors and controls in accordance with [UFC 4-211-01N](#).

4-4.7 **Building Insulation.**

Insulate building walls, roof, and floor in accordance with [UFC 4-211-01N](#).

4-4.8 **Surface Treatment.**

In addition to the requirements in paragraph 2-3.8, provide walls, inside surfaces of doors, and ceilings of work-bays with a light-colored, smooth, hard surface.

4-4.9 **Exterior Pavement.**

Exterior paved areas of the hangar include aircraft and vehicle access and non-organizational parking. Aircraft pavement should be in accordance with [UFC 3-260-02](#), and vehicle access and parking should be in accordance with [MIL-HDBK-1190](#).

4-4.10 **Use Group Classifications.**

PMB hangar bay area shall be classified by the IBC as a Factory and Industrial use group F-1.

4-4.11 **Housekeeping.**

Good housekeeping practices are essentially to the safe operation of a PMB facility. Visible dust layers shall not be allowed to accumulate such that the color of a surface is no longer discernable.

4-4.12 **Other Architectural Requirements**

- a. Isolate the abrasive blasting rooms from other processes, functions, and activities to eliminate contamination.”
- b. Doors on blast-cleaning rooms shall be operable from both inside and outside, except that where there is a small operator access door, the large work access door may be closed or opened from the outside only
- c. An observation window and an access door in accordance with [OSHA 1910.94](#) and [ANSI Z9.4](#) shall be provided. Position the observation

window in the blast room walls and door as necessary so workers inside the room can be seen from outside the room at all times. Use several doors and windows in large rooms.

d. Provide rubberized floor covering to reduce potential for concrete floor to deteriorate and introduce contaminants into the media.

e. Provide emergency exits on opposing walls. Make sure personnel doors are operable from both inside and outside of the room. Doors shall be flanged and tight when closed.

f. Minimize the area of a blasting room to deduce the volumetric airflow rate. However, allow at least 4 feet of clearance between the work piece and the ceiling, walls and doors of the room. Add extra clearance to accommodate internal fixtures such as racks or stands. \4V

#### **4-5 MECHANICAL REQUIREMENTS.**

Design the paint-finishing hangar to meet the criteria set forth in [UFC 4-211-01N](#), with the following special requirements:

##### **4-5.1 Heating.**

Provide heating systems in accordance with paragraph 2-4.1.

##### **4-5.2 Ventilation for Control of Air Contaminants.**

Provide ventilation systems in accordance with paragraph 2-4.2 \4\except as modified below:

Determine the type of dust hazard and the minimum average air velocity through the blasting enclosure in accordance with [OSHA 1910.94](#). The ventilation systems should be specifically designed to remove dust in the combustible particle size range.

Blast-cleaning enclosures shall be exhaust ventilated in such a way that a continuous inward flow of air will be maintained at all openings in the enclosure during the blasting operation.

The air exhausted from blast-cleaning equipment shall be discharged through dust collecting equipment.

Use centrifugal fans with backward curved blades, whenever possible. Centrifugal fans with radial blades are less efficient, but still acceptable. Place the exhaust fan and outlet ductwork outside of the building.

In the case of walk-in blasting rooms, the design should be so that the air flows from either the ceiling to the floor (downdraft) or from one wall to the opposite wall (crossdraft). Note: Consideration should also be given to the geometry of the room, and how work pieces are positioned within the room, the number of workers, and their locations when selecting a downdraft or a crossdraft design. The downdraft design provides superior visibility. In addition, a downdraft design is preferred since contaminated air is usually drawn away from the worker's breathing zone.

Interlock the ventilation system with the blasting equipment power supply. This will prevent the use of the blasting equipment without proper ventilation controls.  
/4/

#### **4-5.3 Air Conditioning.**

Provide air conditioning systems for administrative areas in accordance with paragraph 2-4.1.

#### **4-5.4 Plumbing.**

Provide plumbing systems in accordance with paragraph 2-4.3. Provide an industrial waste system if required by facility pollution control procedures for control of paint stripping residue. Locate storm water drains at least 310 mm (12 in) from the hangar access door rails.

#### **4-5.5 Compressed Air.**

Provide compressed air in accordance with paragraph 2-4.4.

#### **4-5.6 Noise and Vibration Control.**

Design mechanical systems and equipment to limit noise and vibration in accordance with [UFC 3-450-01](#).

#### **4-5.7 PMB Reclamation.**

Design mechanical system and equipment to reclaim, and recycle the plastic media. \4\The media reclamation design should be in accordance with [OSHA 1910.94](#). Do not integrate the exhaust ventilation system with the media recovery system. Protect the media recovery system and ductwork from moisture and rainwater intrusion to keep the media from caking and plugging up the system. Consider using pneumatic recovery system instead of mechanical recovery system for plastic media (Mechanical systems tend to abrade the media).

Dust collectors shall be set up so that the accumulated dust can be emptied and removed without contaminating other working areas./4/

#### 4-6 ELECTRICAL REQUIREMENTS.

Provide electrical systems, including power, lighting and grounding, in accordance with paragraph 2-5.

##### 4-6.1 Hazardous Classification.

The focus of the design shall be to maintain the PMB facility as an unclassified space per the definitions of locations requiring hazardous classification, [NFPA 70](#).

The premise of the design for PMB hangars is that given the combination of the quantity of dust, and the adequacy and interlocking of dust removal, it is not possible for dust concentrations to develop that require classification of any areas of the building. Dust removal and ventilation systems are specifically designed to remove dust in the combustible particle size range. In addition good housekeeping practices should be maintained as a supplement to the dust elimination and ventilation.

##### 4-6.2 Grounding.

Provide the maintenance hangar with flush mounted, floor power ground receptacles, each with a 19 mm (3/4-inch) diameter ground rod, located at a minimum of 7.3 m (24 foot) centers across the centerline of the OH space. Locate additional power ground receptacles around dedicated aircraft parking areas to facilitate the use of grounding connections. When aircraft are parked outside of the hangar, provide static ground receptacles on parking aprons. Resistance to ground for ground power must not exceed **10 ohms** maximum, and for static ground, must not exceed 10,000 ohms in accordance with [MIL-HDBK-274](#) (AS), *Electrical Grounding for Aircraft Safety* and with NAVSEA OP5, *Ammunition and Explosives Ashore Safety Regulations for Handling, Storing, Production, Renovation and Shipping*. Connect ground receptacles together with No. 1/0 AWG minimum bare copper below the hangar floor and connected to the facility grounding system.

∨\ For Air Force Facilities see [UFC 3-260-01](#), Appendix B11 and [AFI 32-1065](#), *Grounding Systems*. /4/

#### 4-7 FIRE PROTECTION.

Design fire protection systems in accordance with paragraph 1-10. **Exception:** Do not provide foam fire protection systems for facilities containing aircraft that have their fuel cells removed. Follow the requirements for unfueled aircraft given in [NFPA 409](#) in this situation.

#### 4-8 ENVIRONMENTAL CONTROLS.

The type of environmental controls required will depend on the pollution abatement regulations at the site and the type and quantities of paints used. Environmental controls can be a major construction and operating cost item; therefore, an accurate determination of regulations and paints (existing and proposed) is required prior to design. /2/

4-9            \4\ **FALL PROTECTION**

See Section 2-9. /4/

CANCELLED

## GLOSSARY

ACGIH	American Conference of Governmental Industrial Hygienists
AFCESA	Air Force Civil Engineer Support Agency
AFIT	Air Force Institute of Technology,
AFRL	Air Force Research Laboratory
AFFF	Aqueous film-forming foam
ASHRAE	American Society of Heating, Refrigerating and Air-Conditioning Engineers
ASME	American Society of Mechanical Engineers
CFD	Computational Fluid Dynamics
cm	centimeter(s)
dBa	decibels A weighted Scale
EPA	U.S. Environmental Protection Agency
DoD	Department of Defense
DODCE	Department of Defense Corrosion Exchange
DOE	Department of Energy
EIA	Electronic Industries Alliance
ft	feet
(HVLP)	High Volume Low Pressure
HQUSACE	Headquarters, U.S. Army Corps of Engineers
IESNA	Illuminating Engineering Society of North America
IWTF	Industrial Waste Treatment Facility
kPa	kiloPascals
m	meter(s)
mm	millimeter(s)
NADEP	Naval Aviation Depot
NAVFAC	Naval Facilities Engineering Command
NESHAP	National Emission Standards For Aerospace Manufacturing And Rework Facilities
NFPA	National Fire Protection Association
NIOSH	The National Institute for Occupational Safety and Health
O/I	Organizational and Intermediate
O&M	Operations and Maintenance
PMB	Plastic Media Blasting
psi	pounds per square inch
UFC	Unified Facilities Criteria
VOC	Volatile organic compounds
3M	Maintenance and Material Management

## APPENDIX A - REFERENCES

### GOVERNMENT PUBLICATIONS

- AFRL-ML-TY-TP-2004-4518, *Cost-Effective Ventilation of a Large Aircraft Painting Facility at Robins AFB, Georgia*, Air Force Research Laboratory, Materials and Manufacturing Directorate Air Expeditionary Forces, Technologies Division, 139 Barnes Drive, Ste 2, Tyndall AFB, FL 32043-5323.
- VA\ *Air Force Corrosion Control Facility Reference Guide*, Change 7, November 2008
- AF ETL 02-15, *Fire Protection Criteria - New Aircraft Facilities*, U.S. Air Force, [http://www.wbdg.org/ccb/AF/AFETL/etl\\_02\\_15.pdf](http://www.wbdg.org/ccb/AF/AFETL/etl_02_15.pdf)
- AF ETL 98-8, *Fire Protection Criteria - Existing Aircraft Facilities*, U.S. Air Force, [http://www.wbdg.org/ccb/AF/AFETL/etl\\_98\\_8.pdf](http://www.wbdg.org/ccb/AF/AFETL/etl_98_8.pdf)
- AFH 32-1084, *Facility Requirements*, U.S. Air Force, [http://www.wbdg.org/ccb/AF/AFH/32\\_1084.pdf](http://www.wbdg.org/ccb/AF/AFH/32_1084.pdf)
- AFI 32-1065, *Grounding Systems*, U.S. Air Force, [http://www.wbdg.org/ccb/AF/AFI/afi\\_32\\_1065.pdf](http://www.wbdg.org/ccb/AF/AFI/afi_32_1065.pdf) /4/
- DOD Directive 4165.61, *Intergovernmental Coordination of DoD Federal Development Programs and Activities*, 9 August 1983, Department of Defense, Washington Headquarters Service, Executive Services and Communication Directorate, Directives and Records Division, <http://www.dtic.mil/whs/directives/>
- MIL-HDBK-274, *Electrical Grounding for Aircraft Safety*, Defense Standardization Program, [https://assist.daps.dla.mil/quicksearch/basic\\_profile.cfm?ident\\_number=53990](https://assist.daps.dla.mil/quicksearch/basic_profile.cfm?ident_number=53990)
- MIL-HDBK-1190, *Facility Planning*, Defense Standardization Program, <http://www.wbdg.org/ccb/NAVFAC/DMMHNAV/1190.pdf>
- NA01-1A-509, *Aircraft Weapons Systems Cleaning and Corrosion Control*, Naval Air Systems Command, <http://www.navair.navy.mil>.
- OP5, *Ammunition and Explosives Ashore Safety Regulations for Handling, Storing, Production, Renovation and Shipping*, Naval Sea Systems Command, <http://www.navsea.navy.mil>.



OSHA 1910.94, *Ventilation*, Occupational Safety and Health Administration,  
[http://www.osha.gov/pls/oshaweb/owadisp.show\\_document?p\\_table=STANDARDS&p\\_id=9734](http://www.osha.gov/pls/oshaweb/owadisp.show_document?p_table=STANDARDS&p_id=9734)

OSHA 1910.107, *Hazardous Materials, Spray Finishing Using Flammable and Combustible Materials*, Occupational Safety and Health Administration,  
[http://www.osha.gov/pls/oshaweb/owadisp.show\\_document?p\\_table=STANDARDS&p\\_id=9753&p\\_text\\_version=FALSE](http://www.osha.gov/pls/oshaweb/owadisp.show_document?p_table=STANDARDS&p_id=9753&p_text_version=FALSE)

\\4\ P-80.3, *Facility Planning Factors Criteria for Navy/Marine Corps Shore Installations Safety Clearance*, Naval Facilities Engineering Command,  
[https://portal.navfac.navy.mil/portal/page/portal/am/am\\_hq/au/au\\_criteriamgmt](https://portal.navfac.navy.mil/portal/page/portal/am/am_hq/au/au_criteriamgmt)

UNIFIED FACILITIES CRITERIA – DRAFT

UFC 3-400-10N, *Mechanical Engineering* (DRAFT)  
[http://www.wbdg.org/ndbm/pdfs/ufc3\\_400\\_10n\\_draft.pdf](http://www.wbdg.org/ndbm/pdfs/ufc3_400_10n_draft.pdf)

UNIFIED FACILITIES CRITERIA  
[http://www.wbdg.org/ccb/browse\\_cat.php?o=29&c=4](http://www.wbdg.org/ccb/browse_cat.php?o=29&c=4)

UFC 1-200-01, *General Building Requirements*

\\4\ UFC 2-000-05N, (P-80) *Facility Planning Criteria for Navy and Marine Corps Shore Installations*, Naval Facilities Engineering Command/4/

UFC 3-260-01, *Airfield and Heliport Planning and Design*

UFC 3-260-02, *Pavement Design for Airfields*

UFC 3-320-07N, *Weight Handling Equipment*

UFC 3-400-01, *Energy Conservation*

UFC 3-410-04N, *Industrial Ventilation*

UFC 3-420-01, *Plumbing Systems*

UFC 3-450-01, *Noise and Vibration Control*

\\4\ UFC 3-501-01, *Electrical Engineering*/4/

UFC 3-530-01, *Design: Interior and Exterior Lighting and Controls*

UFC 3-600-01, *Fire Protection Engineering for Facilities*

UFC 4-010-01, *DoD Minimum Antiterrorism Standards for Buildings*

UFC 4-211-01N, *Aircraft Maintenance Hangars: Type I, Type II, and Type III*  
/4/

UFC 4-451-10N, *Design: Hazardous Waste Storage*

UFC 4-832-01N, *Industrial and Oily Wastewater Control*,

#### **NON-GOVERNMENT PUBLICATIONS**

ACGIH *Industrial Ventilation, A Manual of Recommended Practice*, American Conference of Governmental Industrial Hygienists, 1330 Kemper Meadow Drive, Cincinnati, OH 45240, [www.acgih.org](http://www.acgih.org)

ANSI/AIHA Z9.3, *Spray Finishing Operations - Safety Code for Design, Construction and Ventilation*, American National Standards Institute, 25 West 43rd Street, 4th Floor, New York, NY, 10036, <http://www.ansi.org>

ANSI Z9.2, *Fundamentals Governing the Design and Operation of Local Exhaust Systems*, American National Standards Institute, 25 West 43rd Street, 4th Floor, New York, NY, 10036, <http://www.ansi.org>

ANSI Z9.4, *Exhaust Systems -- Abrasive-Blasting Operations - Ventilation and Safe Practices*, American National Standards Institute, 25 West 43rd Street, 4th Floor, New York, NY, 10036, <http://www.ansi.org>

ANSI/AIHA Z9.7, *Recirculation of Air from Industrial Process Exhaust Systems*, American National Standards Institute, 25 West 43rd Street, 4th Floor, New York, NY, 10036, <http://www.ansi.org>

ANSI/CGA G-7.1-1989 *Commodity Specification for Air*, American National Standards Institute, 25 West 43rd Street, 4th Floor, New York, NY, 10036, <http://www.ansi.org>

NFPA 30, *Flammable and Combustible Liquids Code*, National Fire Protection Association, 1 Batterymarch Park, Quincy, MA, 02169-7471, <http://www.nfpa.org>

NFPA 33, *Standard for Spray Application Using Flammable or Combustible Materials*, National Fire Protection Association, 1 Batterymarch Park, Quincy, MA, 02169-7471, <http://www.nfpa.org>

NFPA 70, *National Electrical Code*, National Fire Protection Association, 1 Batterymarch Park, Quincy, MA, 02169-7471, <http://www.nfpa.org>

NFPA 80, *Standard for Fire Doors and Other Opening Protectives*, National Fire Protection Association, 1 Batterymarch Park, Quincy, MA, 02169-7471, <http://www.nfpa.org>

NFPA 90A, *Standard for the Installation of Air Conditioning and Ventilation Systems*, National Fire Protection Association, 1 Batterymarch Park, Quincy, MA, 02169-7471, <http://www.nfpa.org>

NFPA 101, *Life Safety Code*, National Fire Protection Association, 1 Batterymarch Park, Quincy, MA, 02169-7471, <http://www.nfpa.org>

NFPA 409, *Standard on Aircraft Hangars*, National Fire Protection Association, 1 Batterymarch Park, Quincy, MA, 02169-7471, <http://www.nfpa.org>

NFPA 410, *Standard on Aircraft Maintenance*, National Fire Protection Association, 1 Batterymarch Park, Quincy, MA, 02169-7471, <http://www.nfpa.org>

NFPA 780, *Standard for the Installation of Lightning Protection Systems*, National Fire Protection Association, 1 Batterymarch Park, Quincy, MA, 02169-7471, <http://www.nfpa.org>

*System-Level Computational Fluid Dynamics: Advanced CFD Tools to Solve Problems of Operational Conditions, States of Large-Scale Engineered and Natural Systems*, Southwest Research Institute, 6220 Culebra Road, San Antonio , TX, 78238-5166, <http://www.swri.org>

## **\\ APPENDIX B - OSHA INTERPRETATIONS AND REFERENCES FOR REDUCED AIRFLOW AND RECIRCULATING AIRFLOW**

This appendix is included as an aid to the designer for information regarding OSHA requirements for both reduced airflow velocity in the painting zone and allowance of recirculation of exhaust air when proper measures are taken for corrosion control hangars. The U.S. Air Force, which bears the largest share of corrosion control expenses for its fleets of aircraft, have taken a pro-active approach in these matters. Refer to Appendix B, page, B-4, of AFRL-ML-TY-TP-2004-4518, for a detailed analysis, response and requirements of the OSHA interpretations and supporting calculations for the recirculating model. The following is the Abstract from that publication-

“The text of 29 CFR 1910.107(d)(9), which was imported from the 1969 revision of a fire safety standard, prohibits recirculating ventilation in spray painting facilities. Devices to measure vapor concentrations obsolete this standard almost immediately, but efforts to amend this statement have been frustrated. To accommodate advances in technology, OSHA invoked the designation “de minimis violation” to enable the use of recirculation and other technologies that comply with the most current consensus standards applicable to their operations . . . when the employer’s action provides equal or greater employee protection. Whereas industry has adapted to this expedient, Department of Defense agencies have consistently interpreted that if 107(d)(9) is still in print and the alternative is called a violation, however qualified, military installations will not be given permission to employ exhaust recirculation (ER). Individual bases working in isolation have built a few examples of painting hangars using ER, but each of these facilities suffered from one or more serious design faults. Robins Air Force Base (RAFB), near Macon, Georgia, is acquiring a painting hangar to accommodate painting of C-5 aircraft in an ER ventilation system. Because the economics of exhausting 2.5 million cfm of temperature-controlled air is untenable, critical justification for using ER is provided by RAFB’s environmental conditions, which require cooling and dehumidifying air used in the ventilation process during four to five months each year. This report identifies documentary precedents for competent designs of future paint facilities and describes the preparation and issuance of a design-and-build contract for construction of this new facility at RAFB.”

.....Consistent with the interpretations<sup>12</sup>, <sup>14</sup>, and <sup>16</sup> above, OSHA inspectors did not cite L3 or Air Force facilities using ER ventilation to paint aircraft at Seymour Johnson Air Force Base (SJAFB), N.C., and at Mountain Home AFB (MHAFB), Idaho. SJAFB’s facility design placed a vapor control system inside the ER loop, lowering<sup>17</sup> both total emissions and the increase in exposure within the workplace. The concept earned a 1994 award by EPA for environmental excellence and has profound implications<sup>17</sup> for source reduction strategies.”

The OSHA database for available information and interpretations edited as follows:

"Laws, Regulations and Interpretations provides a comprehensive and easy to use resource for current OSHA standards and enforcement-related information. Interpretations, enforcement guides, and other enforcement related information will be interlinked with regulatory requirements using hypertext links. Not all interpretations which have been issued by OSHA are included on "Laws, Regulations and Interpretations page". Ongoing maintenance is designed to provide the most up-to-date OSHA standards and interpretations of employee safety and health issues, while reducing the duplication of information and removing outdated guidance."

Attached is a list of known interpretations attempting to clarify the use of reduced and recirculating airflow by OSHA. Included in the interpretations are those annotated with an "\*" are no longer available from the database but are included for supporting clarification, establishing the track record of acceptance by OSHA in industry for various allowances over the last 15-20 years. A copy is included at the end of this appendix or through imbedded file links. Interpretations published on the website may be accessed directly by imbedded hyperlink.(Control-enter key on the subject)

Clarification subject Spray Booth vs. Spray Area	1910.107 11/04/1976 - Clarification Paint Spray Booth and Spray Areas <a href="http://www.osha.gov/pls/oshaweb/owadisp.show_document?p_table=INTERPRETATIONS&amp;p_id=18571">http://www.osha.gov/pls/oshaweb/owadisp.show_document?p_table=INTERPRETATIONS&amp;p_id=18571</a>
Recirculation Airflow Allowed	*10/16/1987- A Clarification of requirements for recirculating air discharged from Spray Operations
Recirculation Airflow Allowed	*11/03/1989- Exhaust Air in Spray Operations
Recirculation Airflow Allowed and interpretations of de minimis violations policy	*Jan 16, 1990- From Directorate of Compliance Programs
Recirculation Airflow and the allowance of most concurrent census standards and de minimis violations	*08/27/9991-Spray Booth compliance with OSHA standards is determined at the workplace
De minimis violation Impact/Lack thereof	<a href="#">1995 - 08/03/1995 - Letter requesting a compliance determination of control device system used primarily in paint spray booth applications.</a>
Reduced velocity in paint spray areas	<a href="#">1997 - 04/08/1997 - The airflow rate required for a spray painting area.</a> <a href="#">1996 - 03/15/1996 - Spray Finishing.</a>
OSHA De minimis policy and compliance to NFPA-33 which allows recirculation	<a href="#">1996 - 05/14/1996 - Interpretation for questions related to compliance with NFPA 33 (1995 edition).</a>
OSHA De minimis policy and compliance to NFPA-33 which allows recirculation	

OSHA de minimis policy for reduced airflow rates



- \* UFC-3-410-04-app B.pdf 9-FEB-2000  
VENTILATION RATE FOR FULLY ENCLOSED WALK IN PAINT BOOTH/ROOM

Corrosion Control Hangars treated as spray areas per OSHA because of larger volumes allowing reduced airflows with de minimis policy



- \* UFC-3-410-04-app c.pdf 1-JUL-1999  
INDUSTRIAL VENTILATION RATES IN AIRCRAFT CORROSION CONTROL HANGARS  
[2001 - 10/22/2001 - Clarification of minimum face velocity requirements for spray booths.](#)  
[2001 - 09/17/2001 - Full compliance with NFPA 33-2000 may be considered a de minimis violation.](#)

Reduced Air Velocities Allowed in Spray booths

Recirculation in compliance with NFPA 33, considered a de minimis violation and would not be cited. One of the main standards now cited by the U.S. Air force for corrosion control hangars considered as Spray areas.

(80%) Recirculated air and 20% fresh air) to protect employees in a spray booth from air contaminants. (This is basically the same interpretation the Air force is fully adopting) .

One of the main standards now cited by the U.S. Air force for corrosion control hangars considered as Spray areas  
Spray Booth Compliance

- [2002 - 06/24/2002 - Hierarchy of controls for exposure to air contaminants.](#)

- [2004 - 08/12/2004 - Spray booth requirements including automatic sprinkler systems, relationship to NFPA 33 requirements, and paint storage.](#)  
1910.94

Reduction of Airflow velocities in Paint Booths

- [2001 - 10/22/2001 - Clarification of minimum face velocity requirements for spray booths.](#)  
[1997 - 04/08/1997 - The airflow rate required for a spray painting area.](#)

Reduction of Airflow velocities in Paint Booths

/2/



clarification of requirements for recirculating air discharged from spray operations.

**Record Type:** Interpretation  
**Standard Number:** 1910.107  
**Subject:** A clarification of requirements for recirculating air discharged from spray operations.  
**Information Date:** 10/16/1987

---

Oct 16 1987

Mr. David K. Branstutter  
P.O. Box 178241  
Lucasville, Ohio 45699-0001

Dear Mr. Branstutter:

This is a follow-up to our September 18 response to your letter dated September 1, addressed to Mr. E. Ross Buckley, Chairman, Occupational Safety and Health Review Commission, concerning the recirculation of air discharged from paint booths and the use of electronic air filters to filter the recirculated air. Your letter has been referred to the Occupational Safety and Health Administration (OSHA) for response.

Section 29 CFR 1910.107 of OSHA's General Industry Standards applies to spray finishing operations using flammable and combustible materials. Paragraph (d)(9) of this Section (copy enclosed) specifically prohibits recirculating air discharged from spray operations. However, if the workplace is in compliance with a current industry consensus standard, or if the employer's workplace is at the state-of-the-art and provides equal or greater safety and health protection to the workers but differ from OSHA's requirements, a violation of the applicable OSHA standard may be considered to be *de minimis* (see enclosure).

The National Fire Protection Association (NFPA) 33-1985 standard paragraph 5-6.1 allows the recirculation of air discharged from a spray operation if the recirculated air has been decontaminated to an acceptable level. In addition, the same NFPA standard required that the decontaminated air stream be monitored by approved equipment that signal the operator and automatically shutdown the spray operation in the event of failure of the decontamination equipment. Therefore, if you desire to recirculate air discharged from paint spray booths, you must meet or exceed the requirements of NFPA 33-1985 paragraph 5-6.1.

There are several air cleaning mechanisms in use including filtration, absorption, adsorption, centrifuging, electrostatic precipitation (electronic filter), and incineration. Electrostatic precipitators are mainly used to collect particulates and not gases and vapors. For your purpose, to remove gases, vapors and particulates, a combination of electronic and absorption cleaning devices may be necessary.

Section 29 CFR 1910.107(c)(5) of OSHA's General Industry Standards in part reads, "Unless specifically approved for locations containing both deposits of readily ignitable residue and explosive vapors, there shall be no electrical equipment in any spraying area, whereon

deposits of combustible residues may readily accumulate..."  
Therefore, since electrostatic precipitators produce sparks, the use of such devices in a spray area where flammable liquids are used must be engineered to meet the requirements of the above standard.

OSHA does not endorse or promote any products. Therefore, we cannot recommend any particular manufacturer of electronic air filters. The Thomas Register of American Manufacturers does contain names, telephone numbers, and addresses of the manufacturers of air cleaning equipment, electronic air filters and air contaminant monitors. You may wish to contact these firms for the information you need. Thomas Registers are available in most public libraries. We recommend, however, that you check with the manufacturer of the electronic air filter of your choice to assure that the equipment will safely remove the type of contaminant in your spray area. Additionally, you may explore the feasibility of using heat pumps to extract heat from the air discharged from your spray booth.

I hope this information is useful to you.

Sincerely,

Edward J. Baier  
Director  
Directorate of Technical Support

Enclosures

cc: Baier, Abadir, Loo, CCU #39976 (Due Date: 10-16-87), files  
DTS/LLong/9-24-87/ Room N3653; x37031  
Sheila 20

September 1, 1987

E. Ross Buckley, Chairman  
Occupational Safety and  
Health Review Commission  
1825 K Street, N.W.  
Washington, D.C. 20006

Dear Mr. Buckley,

I own a body shop and am losing alot of heat due to my paint booth. Currently, I use a blower (with common air filters) to supply shop air to the paint booth and another blower forces the paint-contaminated air out an exhaust vent.

What I would like to do is recirculate the air back into the shop and prevent any heat loss. I can use filters to catch the paint particles, but I am not sure if an electronic air filter will remove paint fumes.

It is my understanding that there are industrial electronic air filters and they are capable of removing all types of toxic fumes. If at all possible, would you please supply me the names and addresses of companies which manufacture industrial electronic air filters? Also, would you please recommend a couple models?

Incidentally, if I can safely recirculate the paint booth's air back into my shop area, are there any devices I can buy which will permit me to monitor the air to ensure my industrial electronic air filter



is working properly?

I would appreciate a response concerning this matter as expeditiously  
as possible.

Sincerely,

David K. Branstutter  
P.O. Box 178241  
Lucasville, Ohio 45699-0001

CANCELLED

NOV-12-1996 10:41 FROM ACUREX ENVIRONMENTAL/ENR TO

Page 1 of 2

Exhaust air in spray operations.



U.S. Department of Labor  
Occupational Safety & Health Administration  
OSHA Computerized Information System (OCIS)

Exhaust air in spray operations.

- Record Type: Interpretation
- Subject: Exhaust air in spray operations.
- Information Date: 11/03/1989

November 3, 1989

Mr. Thomas J. Slavin  
Manager, Health and Safety  
Navistar International Transportation Corp.  
401 North Michigan Avenue  
Chicago, Illinois 60611

Dear Mr. Slavin:

This is in response to your letter of August 23, requesting an Occupational Safety and Health Administration (OSHA) interpretation on the use of recirculation of the exhaust air in spray operations in a manner that conforms to the requirements of the National Fire Protection Association (NFPA), NFPA 33-1985, Standard for Spray Application Using Flammable and Combustible Materials. You indicated in your letter that the operation you described conforms to all current NFPA standards.

Sections 5-8.1 and 5-8.2 of NFPA 33-1985 allow recirculation of exhaust air into the spray operation(s), if the exhaust air has been decontaminated to return to safe, acceptable composition, and listed equipment monitors the decontaminated exhaust air stream to signal the operator and to automatically shut down the operation in the event of a malfunction.

In the spray paint operation, you stated that the exhaust air, after being returned to the spray booth, does not increase the flammable levels of concentrations inside the booth over 6 percent of the Lower Flammable Limits (LFL), and that this is accomplished through the use of a filtering system and monitoring equipment. The 6 percent level is well below the safe levels of concentrations (below 25 percent of LFL) prescribed by NFPA.

Under the policy of de minimis violations, copy enclosed, OSHA recognizes an employer to be in compliance with the Occupational Safety and Health Act (OSH Act) if it at least complies with the applicable industry consensus standards, such as NFPA standards, and provides equivalent or greater levels of protection to employees who may be exposed to hazards. Based upon this policy and the information provided in your letter, we interpret that you provide for compliance with the OSH Act, if safe levels of concentrations are maintained within the specified operations. In operations such as maintenance activities, during which employee exposure is possible, use of positive pressure full face air respirators in

Friday, November 08, 1996

11:57 AM

NOV-12-1996 10:42 FROM ALOREX ENVIRONMENTAL/ERU TO

241/001 P.03

Exhaust air in spray operations.

Page 2 of 2

compliance with 29 CFR 1910.114 is required.

If we may be of further assistance, please contact us. Thank you for your interest in safety and health.

Sincerely,

Alan C. McMillan  
Acting Assistant Secretary

Enclosure

CANCELLED

Friday, November 08, 1996

11:57 AM

TOTAL P.03

U.S. Department of Labor

Occupational Safety and Health Administration  
Washington, D.C. 20210

Reply to the Attention of:

From: Charles H. Daryin  
AFERL



JAN 16 1990

Susan R. Wyatt, Chief  
Chemicals and Petroleum Branch  
Emission Standards Division  
U.S. Environmental Protection Agency  
Office of Air Quality Planning and Standards  
Research Triangle Park, North Carolina 27711

Dear Ms. Wyatt:

This is in response to your letter of October 31, 1989, concerning the Occupational Safety and Health Administration (OSHA) regulation at 29 CFR 1910.107(d)(9) which prohibits the recirculation of exhaust air from spray finishing operations. Please excuse the delay in response.

As you are aware, 29 CFR 1910.107 was adopted from the NFPA 33-1969, Standard for Spray Finishing Using Flammable and Combustible Materials. The NFPA-33 standard is explicitly a fire and explosion safety standard. Therefore, the OSHA standard at 29 CFR 1910.107 pertains to the prevention of workplace fire and explosion hazards and does not pertain to health considerations.

Although the NFPA has updated their standard since the 1969 edition, OSHA has not. As a result, the current NFPA 33-1985, Spray Application Using Flammable and Combustible Materials, reflects the most up to date state of the art concerning the prevention of fire and explosion hazards during spray finishing operations.

Under an OSHA policy for "de minimis violations", employers are encouraged to abide by the most current consensus standard applicable to their operations, rather than with the standard in effect at the time of the inspection when the employer's action provides equal or greater employee protection. De minimis violations are violations of existing OSHA standards which have no direct or immediate relationship to safety or health. Such violations of the OSHA standards result in no citation, no penalty and no required abatement. A copy of the OSHA policy for de minimis violations is enclosed.

OSHA Instruction CPL 2.45B  
JUN 15 1989  
Office of General Industry Compliance Assistance

6. **De Minimis Violations.** De minimis violations are violations of standards which have no direct or immediate relationship to safety or health. Whenever de minimis conditions are found during an inspection, they shall be documented in the same way as any other violation but shall not be included on the citation.
- a. **Explanation.** The criteria for finding a de minimis violation are as follows:
- (1) An employer complies with the clear intent of the standard but deviates from its particular requirements in a manner that has no direct or immediate relationship to employee safety or health. These deviations may involve distance specifications, construction material requirements, use of incorrect color, minor variations from recordkeeping, testing, or inspection regulations, or the like.  
  
EXAMPLES: (a) 29 CFR 1910.27(b)(1)(ii) allows 12 inches as the maximum distance between ladder rungs. Where the rungs are 13 inches apart, the condition is de minimis.  
  
(b) 29 CFR 1910.28(a)(3) requires guarding on all open sides of scaffolds. Where employees are tied off with safety belts in lieu of guarding, the intent of the standard is met; and the absence of guarding is de minimis.  
  
(c) 29 CFR 1910.217(e)(1)(ii) requires that mechanical power presses be inspected and tested at least weekly. If the machinery is seldom used, inspection and testing prior to each use is adequate to meet the intent of the standard.
  - (2) An employer complies with a proposed standard or amendment or a consensus standard rather than with the standard in effect at the time of the inspection when the employer's action provides equal or greater employee protection.
  - (3) An employer's workplace is at the "state of the art" which is technically beyond the requirements of the applicable standard and provides equivalent or more effective employee safety or health protection.
- b. **Professional Judgment.** Maximum professional discretion must be exercised in determining the point at which noncompliance with a standard constitutes a de minimis violation.
- c. **Area Director Responsibilities.** Area Directors shall ensure that the de minimis violation meets the criteria set out in B.6.a.

Employers who fully comply with the specifications and requirements of the NFPA 33-1989, concerning the recirculation of exhaust air to an occupied spray booth, would not be cited under 29 CFR 1910.107(d)(9) under the policy for de minimis violations. However, the quality of the respirable air in the booth must comply, at a minimum, with the requirements set forth by 29 CFR 1910.1000 which establishes permissible exposure limits (PEL's).

If we may be of further assistance, please contact us.

Sincerely,

  
Thomas J. Shepich, Director  
Directorate of Compliance Programs

CANCELLED



**Spray booth compliance with OSHA standards is determined at the work place.**

**Record Type:** Interpretation  
**Standard Number:** 1910.107  
**Subject:** Spray booth compliance with OSHA standards is determined at the work place.  
**Information Date:** 08/27/1991

---

August 27, 1991

Mr. Tom Ellis  
Director of Sales and Marketing  
Classic Systems, Inc.  
P.O. Box 6130  
Buffalo Shoals Road  
Statesville, North Carolina 28677

Dear Mr. Ellis:

This is in response to your letter of June 19, in which you request Occupational Safety and Health Administration (OSHA) verification that your new spray booth, in consideration of the design information provided, meets or exceeds 29 CFR 1910.107 standards. You have provided limited information, that is, an isometric depiction, generally stated design features and air flow velocities at different locations of your spray booth, on which to determine compliance with OSHA standards.

Withstanding sufficient information from the manufacturer, spray booth compliance with OSHA standards is determined at the work place.

Employers are subject to compliance with OSHA standards which address the safety and health of employees involving in workplace spray booth operations intended to confine finishing applications consisting of flammable or combustible materials. Applicable OSHA standards include not only 29 CFR 1910.107, which pertains to the prevention of workplace fire and explosion hazards but also 29 CFR 1910.1000, which pertains to prevention of harmful exposure of employees to workplace toxic and hazardous substances.

Originally, 29 CFR 1910.107 was adopted from the NFPA 33-1969, Standard for Spray Finishing Using Flammable and Combustible Materials. Although the NFPA has updated its standard since the 1969 edition, OSHA has not. As a result, the current NFPA 33-1969, Spray Application Using Flammable and Combustible Materials, reflects the most up-to-date state of the art concerning the prevention of fire and explosion hazards during spray finishing operations.

Under an OSHA policy for "de minimis violations", employers are allowed to abide by the most current consensus standard applicable to their operations, rather than with the standard in effect at the time of the inspection, when the employer's action provides equal or greater employee protection. De Minimis violations are violations of existing OSHA standards which have no direct or immediate relationship to safety or health. Such violations of the OSHA standards result in no citation, no penalty and no required abatement.

Employers who fully comply with the specifications and requirements of the NFPA 33-1989, concerning the recirculation of exhaust air to an occupied

spray booth, would not be cited under 29 CFR ~~1910.107(d)(2)~~ under the policy for de minimis violations. However, the quality of the respirable air in the booth must comply, at a minimum, with requirements set forth by 29 CFR ~~1910.1000~~ which establishes permissible exposure limits (PEL's).

~~Recirculating contaminated air within the spray booth to accumulate volatile organic compounds (VOC) emission for periodic incineration must be considered with respect to the intent of section 5(a)(1) of the OSH Act, which requires each employer to furnish to each of his employment which are free from recognized hazards that are causing or likely to cause death or serious physical harm to his employees. In determination of compliance with OSHA safety and health standards, personal protective clothing is considered supplemental to engineering controls and administration practices to protect employees from exposure to hazards in the workplace.~~

Sincerely,

Patricia K. Clark, Director  
Directorate of Compliance Programs

CANCELLED



**\2\ APPENDIX C - BUILDING TEMPLATES**

<b>DRAWING</b>	<b>TYPE</b>	<b>SHEET</b>	<b>DATE</b>	<b>PLATE NO.</b>	<b>STATUS</b>
Corrosion Control Hangar	A-SMALL (PLAN)	1 OF 4	6-06-05	211-03	Reference Only
Corrosion Control Hangar	A-SMALL (F&R ELEV)	2 OF 4	6-06-05	211-03	Reference Only
Corrosion Control Hangar	A-SMALL (SECTION)	3 OF 4	6-06-05	211-03	Reference Only
Corrosion Control Hangar	A-SMALL (DESIGN INFO)	4 OF 4	6-06-05	211-03	Reference Only
Corrosion Control Hangar	B-LARGE (PLAN)	1 OF 5	6-06-05	211-03	Reference Only
Corrosion Control Hangar	B-LARGE (F&R ELEV)	2 OF 5	6-06-05	211-03	Reference Only
Corrosion Control Hangar	B-LARGE (SECTION)	3 OF 5	6-06-05	211-03	Reference Only
Corrosion Control Hangar	B-LARGE (DESIGN INFO)	4 OF 5	6-06-05	211-03	Reference Only
Corrosion Control Hangar	B-LARGE (ISOMETRIC)	5 OF 5	6-06-05	211-03	Reference Only

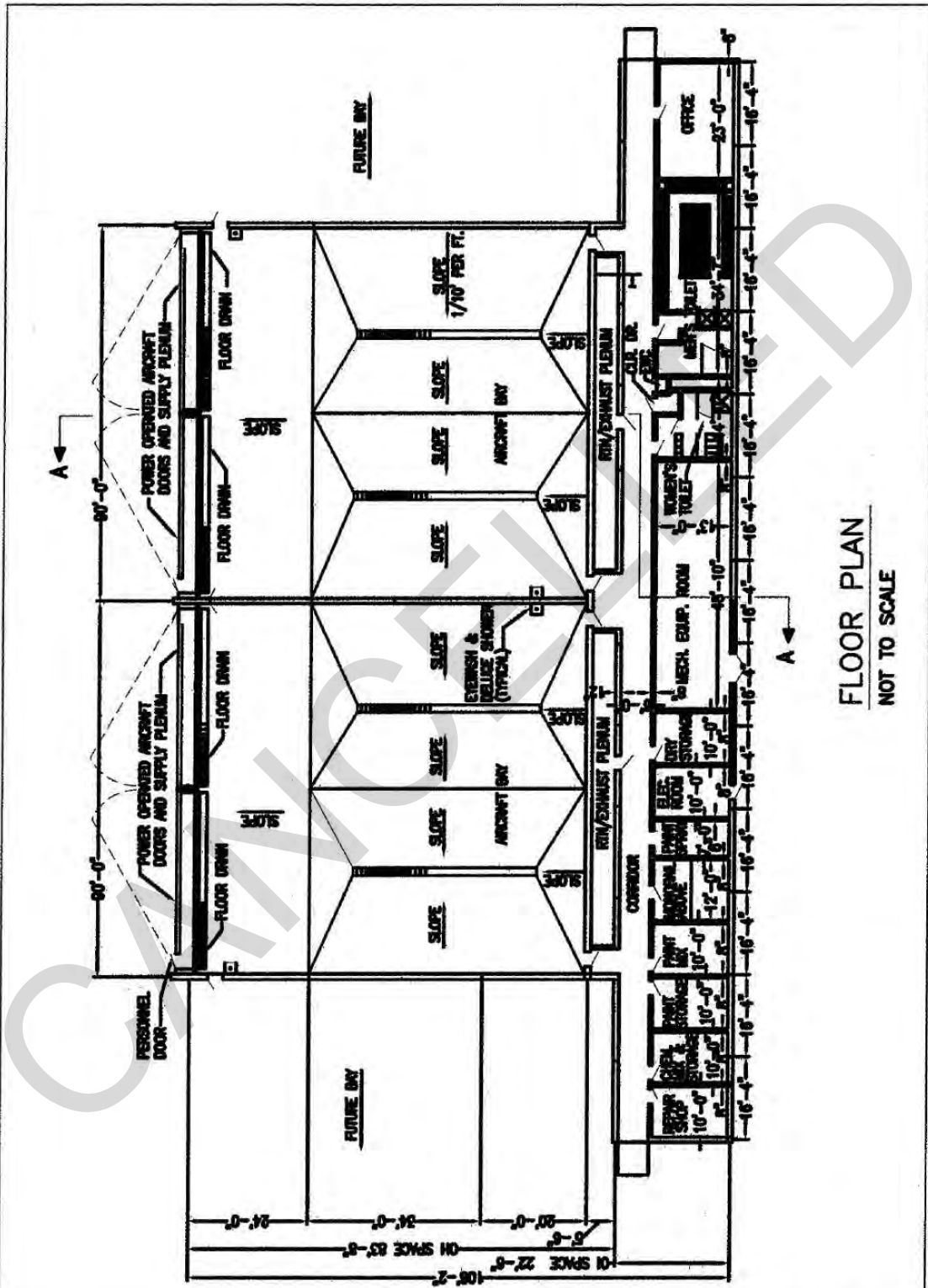

FLOOR PLAN  
 NOT TO SCALE

<p>TITLE:                  CORROSION CONTROL HANGAR                  TYPE "A" SMALL</p>	<p>DATE                  6/06/05</p>	<p>FACILITY PLATE NO.                  211-03</p>	<p>SHEET                  1 OF 4</p>
---	--	---	--

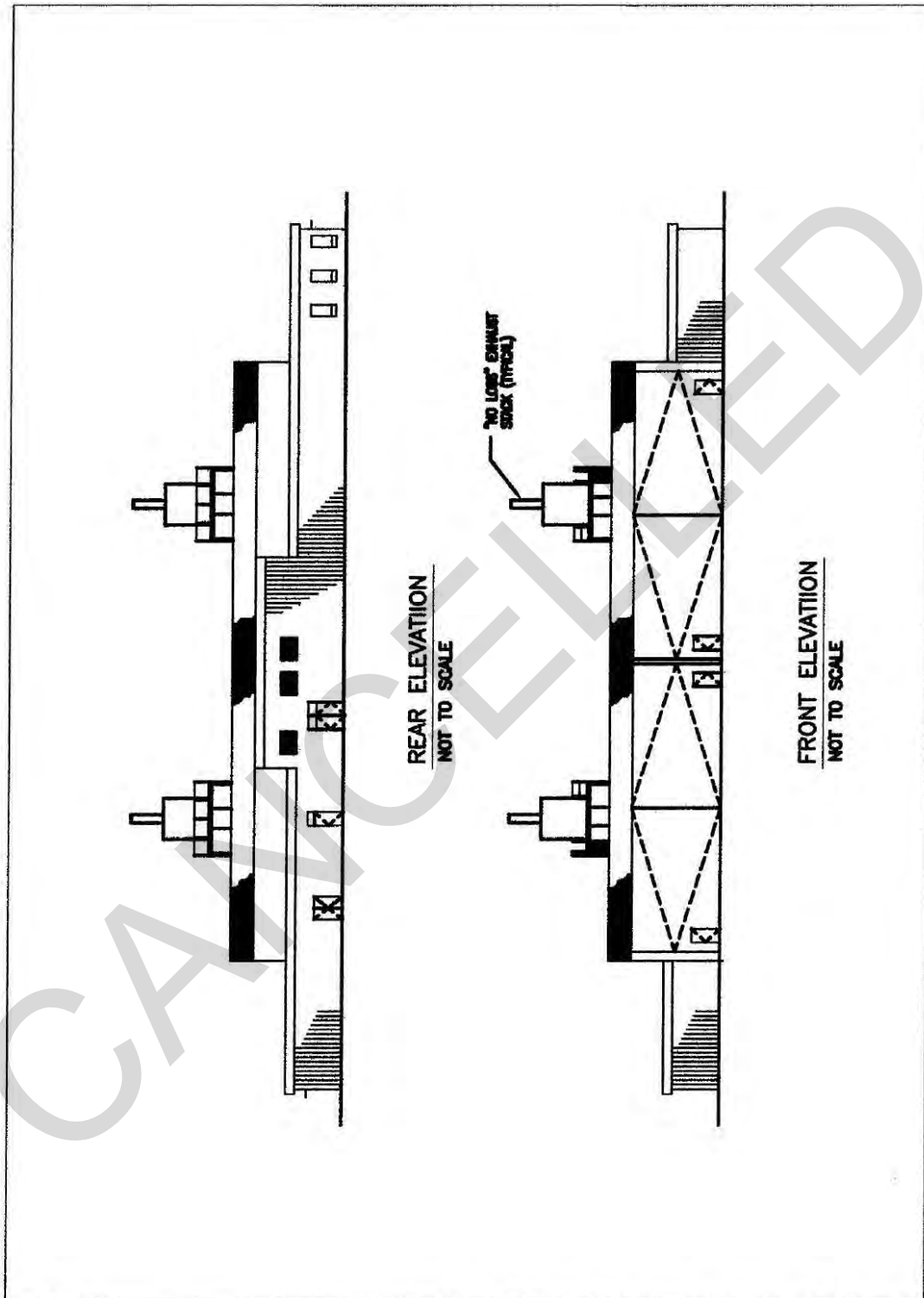

TITLE: CORROSION CONTROL HANGAR TYPE "A" SMALL	DATE 6/06/05	FACILITY PLATE NO. 211-03	SHEET 2 OF 4
--	-----------------	------------------------------	-----------------

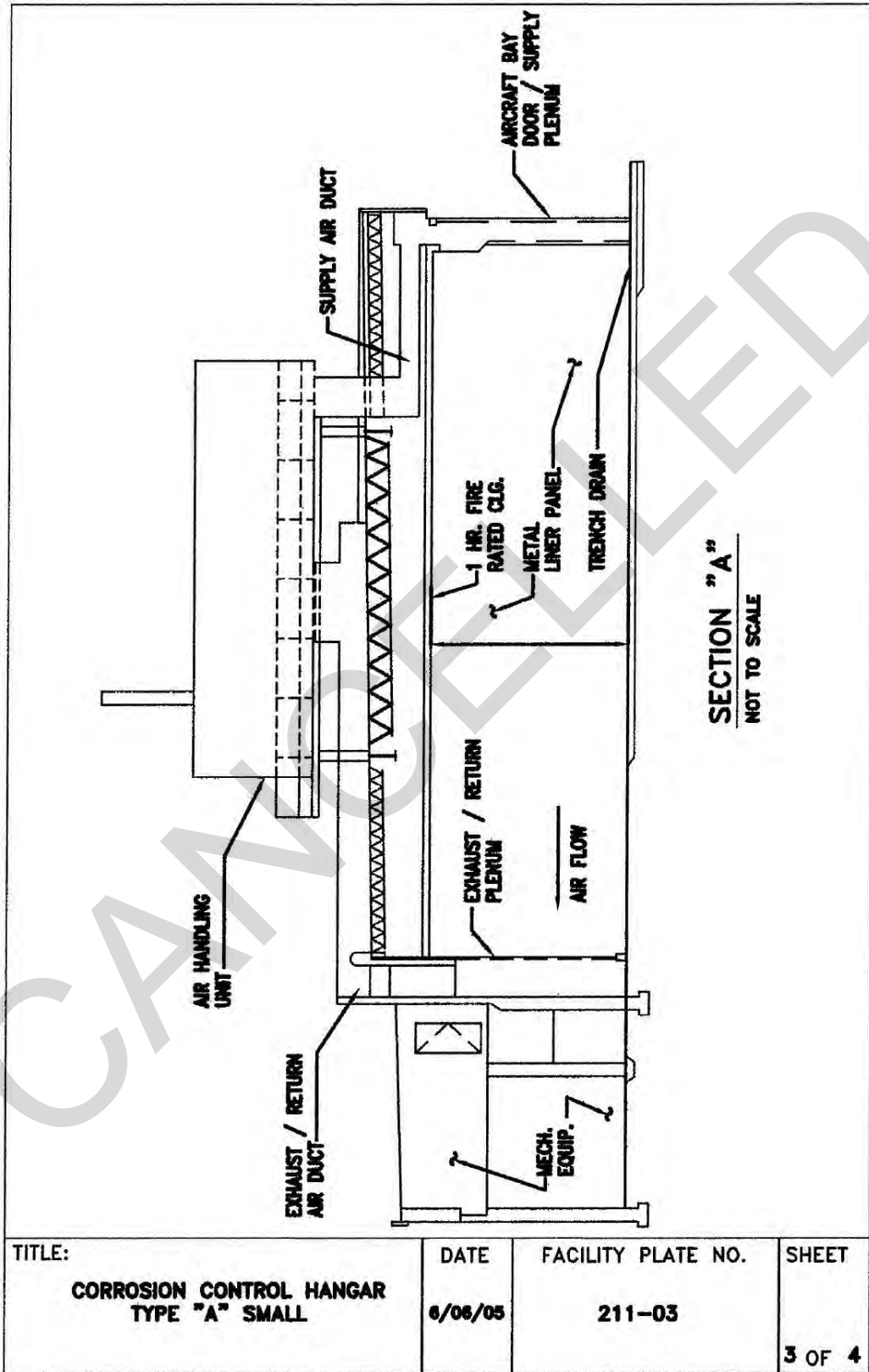

## NOTES

### PLUMBING REQUIREMENTS

COLD WATER	65 G.P.M.
HOT WATER (OI SPACE)	40 G.P.H.
RECOVERY RATE (THRU 100° F RISE)	
STORAGE	40 GAL.

### FIRE PROTECTION REQUIREMENTS

SPRINKLERS (FOAM-WATER)	1123 G.P.M.
OSCILLATING NOZZLES	702 G.P.M.
HOSE STREAMS	<u>500 G.P.M.</u>
TOTAL (EACH BAY)	2325 G.P.M.

### HEATING REQUIREMENTS \*

INSIDE DESIGN TEMPERATURE	
OH SPACE	85° F
OI SPACE	68° F
OUTSIDE DESIGN TEMPERATURE	
22° F	
HEATING LOAD	
OH SPACE	36,740,000 BTU/HR (W/O HEAT RECOVERY)
OI SPACE	167,000 BTU/HR.

### AIR CONDITIONING REQUIREMENTS \*

INSIDE DESIGN TEMPERATURE	78° F.D.B.
INSIDE DESIGN HUMIDITY	50%
OUTSIDE DESIGN TEMPERATURE	91° F.D.B.
	78° F.W.B.
COOLING LOAD. OFFICE	12,000 BTU/HR

### ELECTRICAL REQUIREMENTS

	MODULE OH SPACE	MODULE OI SPACE
LIGHTS		
CONNECTED LOAD	40	4
POWER		
CONNECTED LOAD	1289	4
TOTAL		
CONNECTED LOAD	1329	8
ESTIMATED LOAD	1273	4
ADDITIONAL DEMAND FOR AIR CONDITIONING OFFICE		2

### BAY DIMENSIONS

BAY DIMENSIONS SHOWN WILL SUPPORT S-3 AIRCRAFT AND PROVIDE 10 FOOT HORIZONTAL AND 6 FOOT VERTICAL CLEARANCE BETWEEN AIRCRAFT AND HANGAR BAY WALLS/DOORS/CEILINGS. REDUCED CLEARANCES SHALL NOT BE USED WITHOUT PRIOR NAVFAC APPROVAL.

\* REQUIREMENTS BASED ON NORFOLK, VIRGINIA AREA.  
 PROVIDE COOLING FOR OFFICE SPACE ONLY.  
 OH SPACE HEATING REQUIREMENTS VARY.  
 VERIFY SPECIFIC FACILITY REQUIREMENTS.

TITLE:	DATE	FACILITY PLATE NO.	SHEET
<b>CORROSION CONTROL HANGAR TYPE "A" SMALL</b>	<b>6/06/05</b>	<b>211-03</b>	<b>4 OF 4</b>

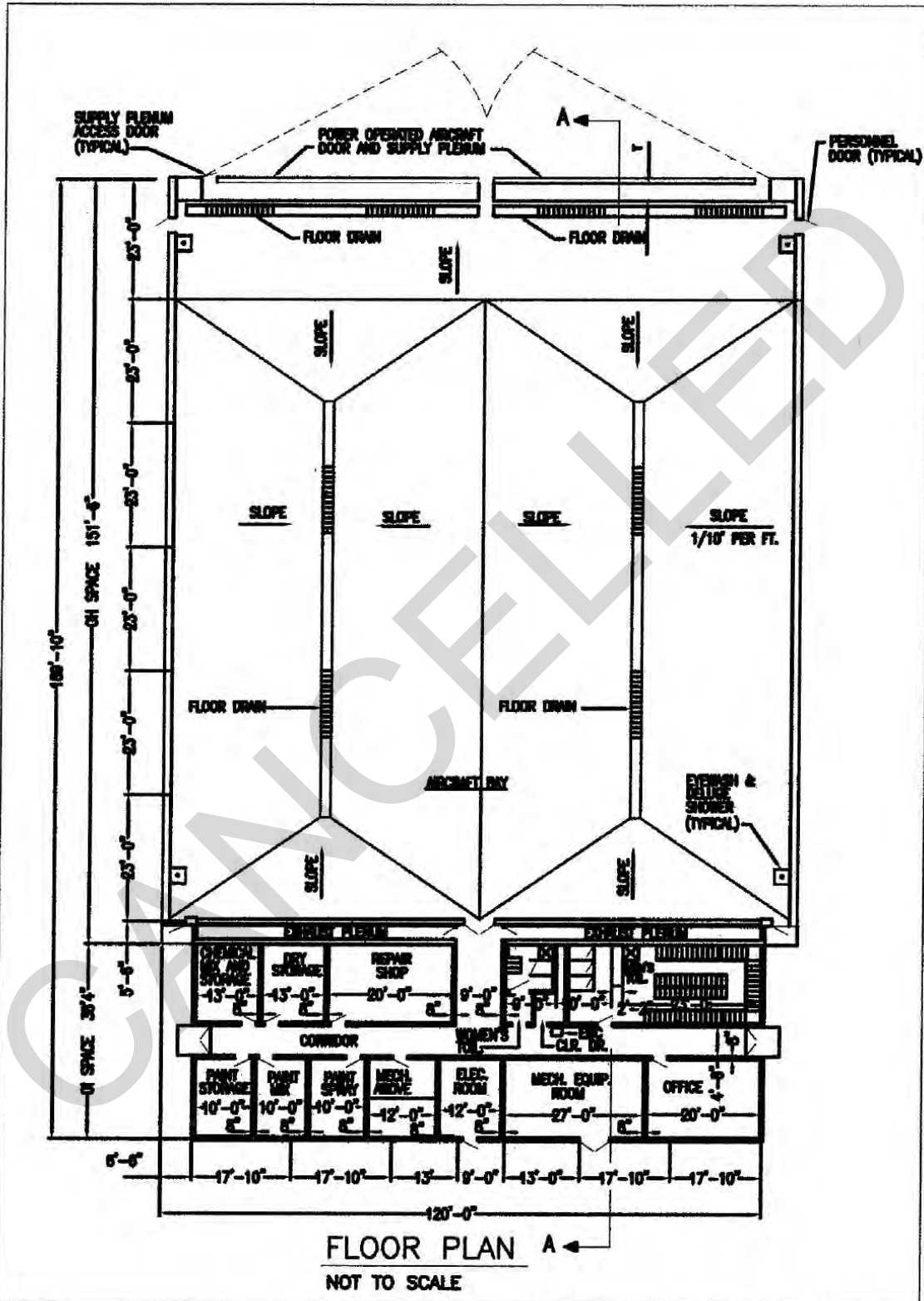

TITLE:	DATE	FACILITY PLATE NO.	SHEET
CORROSION CONTROL HANGAR TYPE "B" LARGE	6/06/05	211-03	1 OF 5

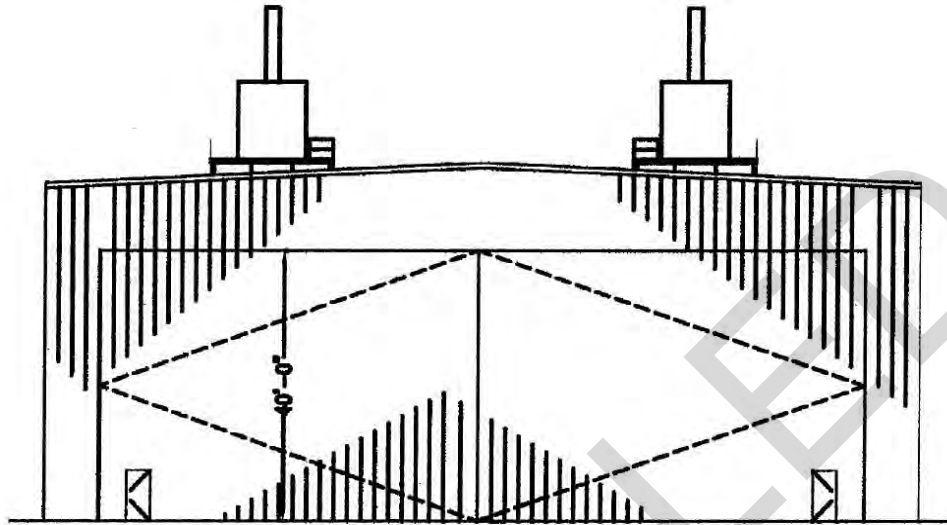

**FRONT ELEVATION**  
**NOT TO SCALE**

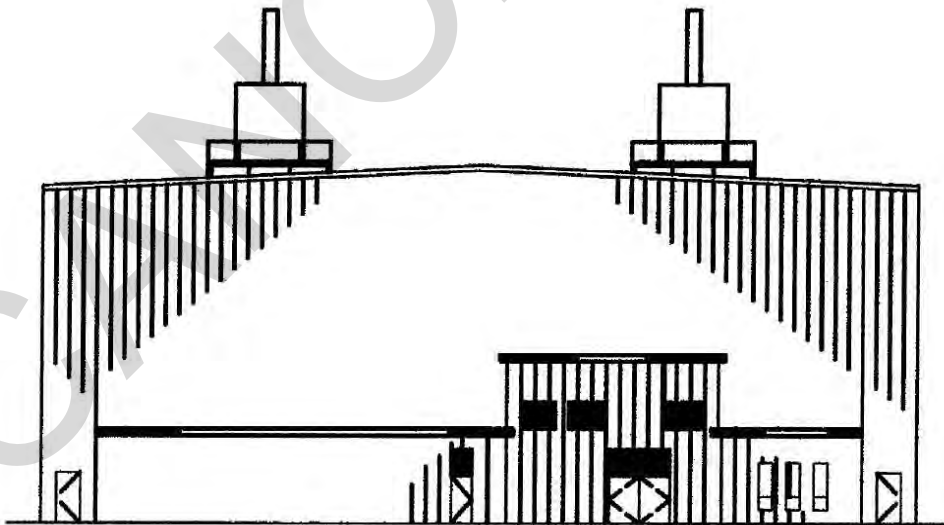

**REAR ELEVATION**  
**NOT TO SCALE**

TITLE:	DATE	FACILITY PLATE NO.	SHEET
CORROSION CONTROL HANGAR TYPE "B" LARGE	6/06/05	211-03	2 OF 5

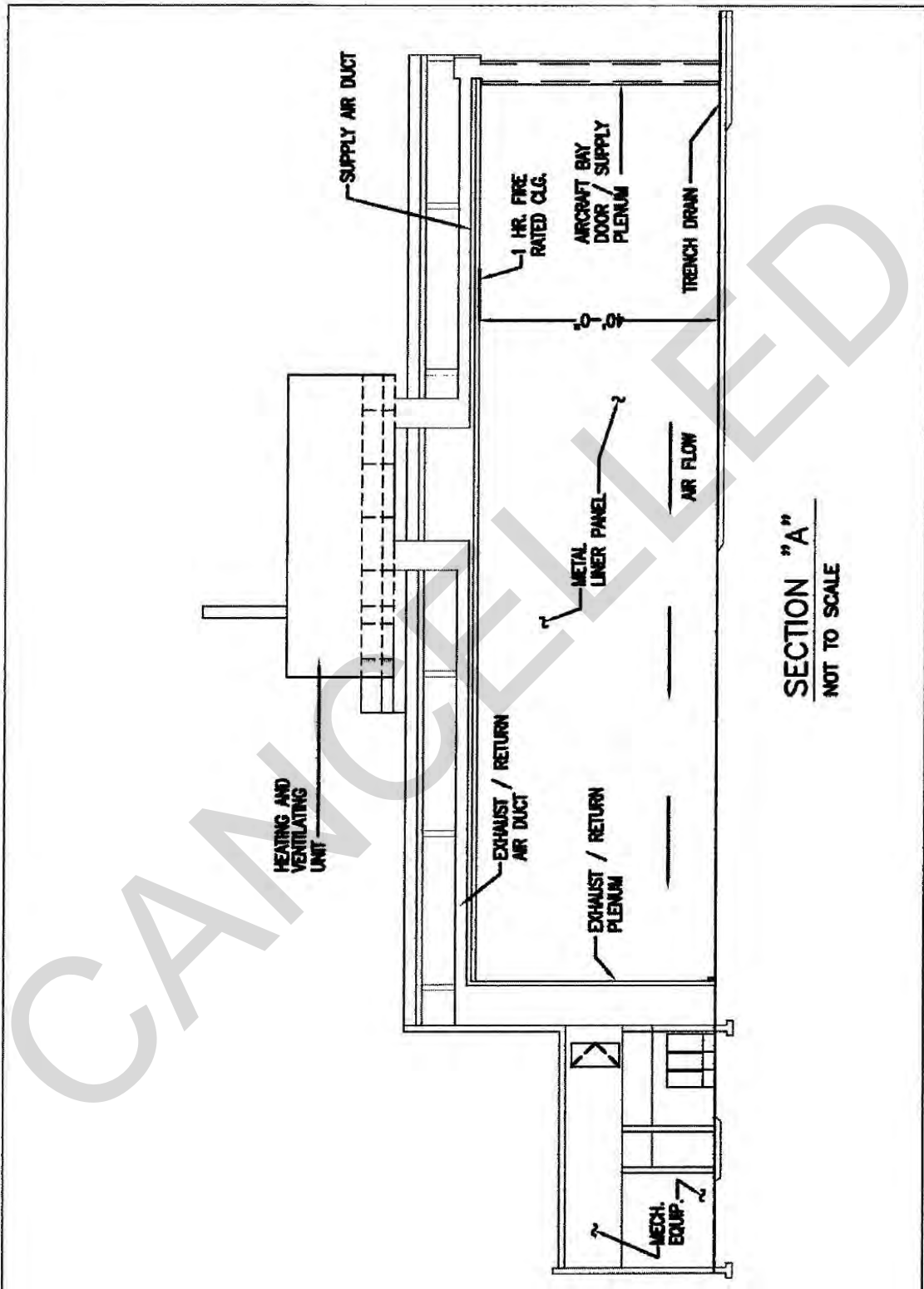

TITLE:	DATE	FACILITY PLATE NO.	SHEET
CORROSION CONTROL HANGAR TYPE "B" LARGE	6/01/05	211-03	3 OF 5



## NOTES

### PLUMBING REQUIREMENTS

COLD WATER	80 G.P.M.
HOT WATER (OI SPACE)	55 G.P.H.
RECOVERY RATE (THRU 100° F RISE)	
STORAGE	55 GAL

### FIRE PROTECTION REQUIREMENTS

SPRINKLERS (FOAM-WATER)	2803 G.P.M.
OSCILLATING NOZZLES	1752 G.P.M.
HOSE STREAMS	500 G.P.M.
TOTAL (EACH BAY)	4555 G.P.M.

### HEATING REQUIREMENTS \*

INSIDE DESIGN TEMPERATURE	
OH SPACE	85° F
OI SPACE	68° F
OUTSIDE DESIGN TEMPERATURE	22° F
HEATING LOAD	
OH SPACE	32,660,000 BTU/HR (W/O HEAT RECOVERY)
OI SPACE	150,000 BTU/HR.

### AIR CONDITIONING REQUIREMENTS \*

INSIDE DESIGN TEMPERATURE	76° F.D.B.
INSIDE DESIGN HUMIDITY	50%
OUTSIDE DESIGN TEMPERATURE	91° F.D.B.
	76° F.W.B.
COOLING LOAD, OFFICE	12,000 BTU/HR

### ELECTRICAL REQUIREMENTS

	MODULE OH SPACE	MODULE OI SPACE
LIGHTS		
CONNECTED LOAD	55	4
POWER		
CONNECTED LOAD	898	4
TOTAL		
CONNECTED LOAD	953	8
ESTIMATED LOAD	877	4
ADDITIONAL DEMAND FOR AIR CONDITIONING OFFICE		2

### BAY DIMENSIONS

BAY DIMENSIONS SHOWN WILL SUPPORT P-3 AIRCRAFT AND PROVIDE 10 FOOT HORIZONTAL AND 8 FOOT VERTICAL CLEARANCE BETWEEN AIRCRAFT AND HANGAR BAY WALLS/DOORS/CEILINGS. REDUCED CLEARANCES SHALL NOT BE USED WITHOUT PRIOR NAVFAC APPROVAL.

\* REQUIREMENTS BASED ON NORFOLK, VIRGINIA AREA.  
 PROVIDE COOLING FOR OFFICE SPACE ONLY.  
 OH SPACE HEATING REQUIREMENTS VARY.  
 VERIFY SPECIFIC FACILITY REQUIREMENTS.

TITLE:	DATE	FACILITY PLATE NO.	SHEET
<b>CORROSION CONTROL HANGAR TYPE "B" LARGE</b>	<b>6/06/05</b>	<b>211-03</b>	<b>4 OF 5</b>

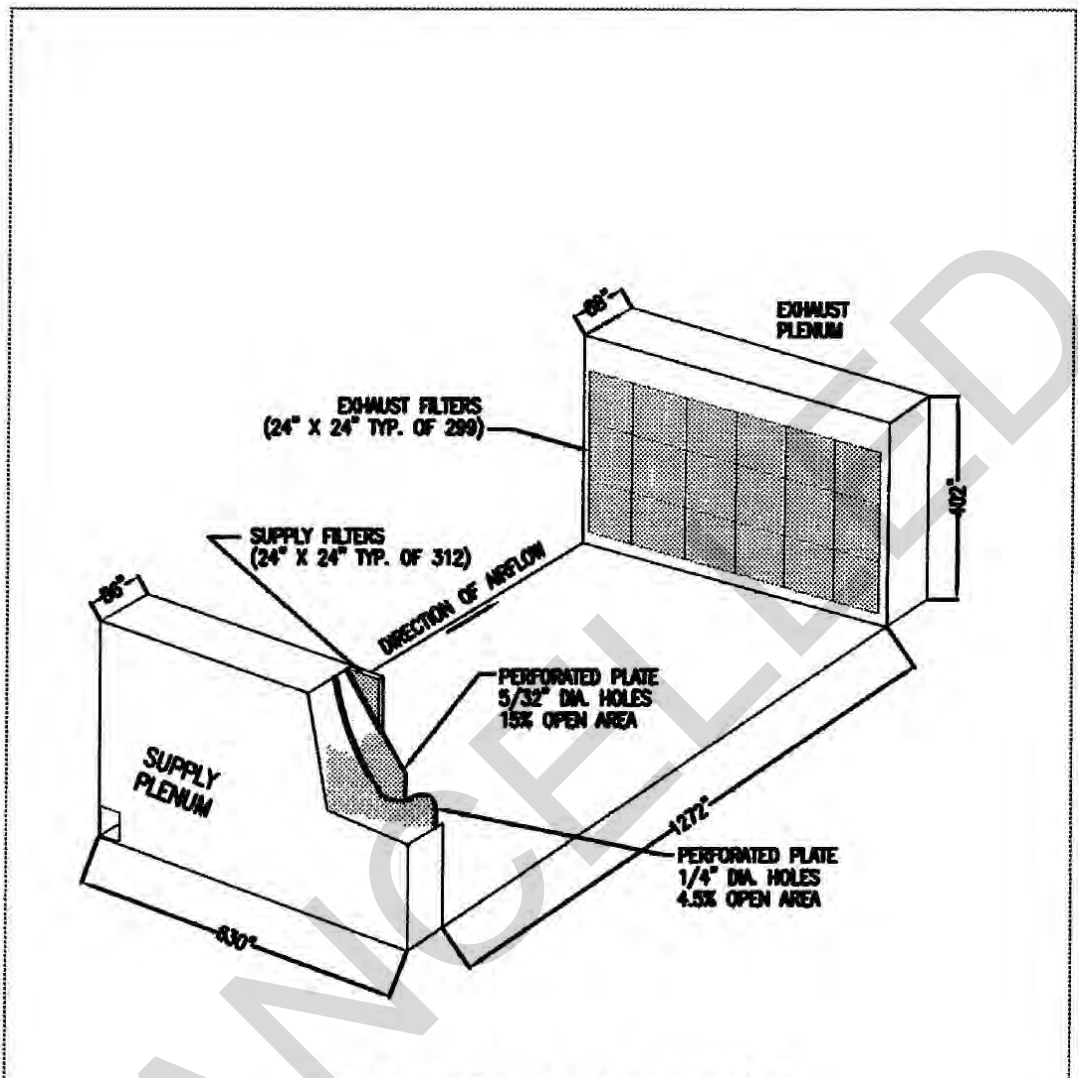

PARTIAL HANGAR BAY ISOMETRIC VIEW  
 WITH EXAMPLE SUPPLY PLENUM DETAILS

TITLE:	DATE	FACILITY PLATE NO.	SHEET
CORROSION CONTROL HANGAR TYPE "B" LARGE	6/06/05	211-03	5 OF 5

12/