

DOD-STD-00100D (AR)

3 APRIL 1987

USED IN LIEU OF

DOD-STD-100C

22 DECEMBER 1978

MILITARY STANDARD
ENGINEERING DRAWING PRACTICES



AMSC N/A

AREA DRPR

DISTRIBUTION STATEMENT A. APPROVED FOR PUBLIC RELEASE; DISTRIBUTION IS UNLIMITED.

DOD-STD-00100D(AR)

DEPARTMENT OF DEFENSE
WASHINGTON, DC 20301

Engineering Drawing Practices

DOD-STD-00100D(AR)

1. This Military Standard is approved for use by all elements of the U.S. Army Tank-Automotive Command and U.S. Army Armament, Munitions and Chemical Command.
2. Beneficial comments (recommendations, additions, deletions) and any pertinent data which may be of use in improving this document should be addressed to: Commander, U.S. Army Armament Research, Development and Engineering Center, ATTN: SMCAR-ESC-S, Picatinny Arsenal, NJ 07806-5000, by using the self-addressed Standardization Document Improving Proposal (DD Form 1426) appearing at the end of this document or by letter.

DOD-STD-00100D(AR)

FOREWORD

This interim Military Standard provides:

Drawing practices for preparation of engineering drawings and drawing format materials.

Definitions and examples of types of engineering drawings to be prepared for the Department of Defense. These are cataloged for appropriate selection and use in support of Levels of engineering drawings being prepared under the requirements of DOD-D-1000.

Procedures for the creation of titles for engineering drawings.

Numbering, coding and identification procedures for engineering drawings, associated lists and documents referenced on these engineering drawings and associated lists.

Methods for revision of engineering drawings and methods for recording of such revisions.

Requirements for preparation of associated lists.

This document applies to all TACOM and AMCCOM contracts which specify delivery of Level 3 drawings in accordance with DOD-D-1000. All drawings which define the Product Baseline shall conform to Level 3. Level 3 drawings should also be acquired for definition of the Allocated Baseline.

DOD-STD-00100D(AR)

THIS PAGE LEFT BLANK INTENTIONALLY

DOD-STD-00100D(AR)

SCOPE

This standard prescribes general requirements for the preparation and revision of engineering drawings and associated lists prepared by or for elements of U.S. Army Tank-Automotive Command and U.S. Army Armament, Munitions and Chemical Command.

DOD-STD-00100D(AR)

REFERENCED DOCUMENTS

Government documents.

Specifications, standards, and handbooks. Unless otherwise specified, the following specifications, standards, and handbooks of the issue listed in that issue of the Department of Defense Index of Specifications and Standards (DoDISS) specific in the solicitation form a part of this standard to the extent specified herein.

SPECIFICATIONSFederal

L-F-340	Film, Diazotype, Sensitized, Moist and Dry Process, Roll and Sheet
L-P-519	Plastic Sheet, Tracing, Glazed and Matte Finish
TT-I-1795	Ink, Marking, Stencil, Opaque (Porous and Non Porous Surfaces)
UU-P-221	Paper, Direct Positive Sensitized, (Diazotype - Moist and Dry Process)
UU-P-561	Paper, Tracing
CCC-C-531	Cloth, Tracing

Military

DOD-D-1000	Drawings, Engineering and Associated Lists
MIL-D-5480	Data, Engineering and Technical, Reproduction Requirements for
MIL-H-6088	Heat Treatment of Aluminum Alloys
MIL-S-6090	Steel, Carburizing and Nitriding, Processes for
MIL-H-6875	Heat Treatment of Steel, Process for
MIL-D-8510	Drawing, Undimensioned, Reproducibles, Photographic and Contact, Preparation of
MIL-M-9868	Microfilming of Engineering Documents, 35mm Requirements for
MIL-W-13855	Weapon, Small Arms and Aircraft Armament Subsystems, General Specification for
MIL-M-38510	Microcircuits, General Specification for

DOD-STD-00100D(AR)

APPLICABLE DOCUMENTS (Cont'd)

SPECIFICATIONSSMilitary

- MIL-M-38761 Microfilming and Photographing of Engineering/
Technical Data and Related Documents: PCAM
Card Preparation, Engineering Data Micro-repro-
duction System, General Requirements for,
Preparation of
- MIL-P-55010 Plastic Sheet, Polyethylene Terephthalate

STANDARDSMilitary

- MIL-STD-12 Abbreviation for Use on Drawings, Specifications,
Standards and in Technical Documents
- MIL-STD-14 Architectural Symbols
- MIL-STD-15-2 Electrical Wiring Equipment Symbols for Ships'
Plans
- MIL-STD-17-1 Mechanical Symbols
- MIL-STD-17-2 Mechanical Symbols for Aeronautical, Aerospace-
craft and Spacecraft Use
- MIL-STD-25 Ship Structural Symbols for Use on Ship Drawings
- MIL-STD-34 Preparation of Drawings for Optical Elements and
Optical Systems, General Requirements for
- DOD-STD-100 Engineering Drawing Practices
- MIL-STD-129 Marking for Shipment and Storage
- MIL-STD-130 Identification Marking of U.S. Military Property
- MIL-STD-171 Finishing of Metal and Wood Surfaces
- MIL-STD-190 Identification Marking of Rubber Products
- MIL-STD-275 Printed Wiring for Electronic Equipment
- DOD-STD-480 Configuration Control - Engineering Changes,
Deviations and Waivers

DOD-STD-00100D(AR)

APPLICABLE DOCUMENTS (Cont'd)

STANDARDSMilitary

MIL-STD-481 Configuration Control - Engineering Changes, Deviations and Waivers (Short Form)

MIL-STD-490 Specification Practices

MIL-STD-681 Identification Coding and Application of Hookup and Lead Wire

MIL-STD-961 Military Specifications and Associated Documents, Preparation of

MIL-STD-1174 Associated Lists for ARRADCOM Engineering Drawings

MIL-STD-1267 Dimensioning of Barrel Chambers of Small Arms Weapons

MIL-STD-1306 Fluorics Terminology and Symbols

MIL-STD-1464 Army Nomenclature System

DOD-STD-1476 Metric System, Application in New Design

DOD-STD-1686 Electrostatic Discharge Control Program for Protection of Electrical and Electronic Parts, Assemblies, and Equipment (excluding Electrically Initiated Explosive Devices) (Metric)

DOD-STD-2167 Defense System Software Development

MIL-STD-2175 Castings, Classification and Inspection of

HANDBOOKS

DOD-HDBK-263 Electrostatic Discharge Control Handbook for Protection of Electrical and Electronic Parts, Assemblies and Equipment (Excluding Electrically Initiated Explosive Devices) Metric

Other Government documents, drawings, and publications. The following other Government documents, drawings, and publications form a part of this standard to the extent specified herein.

12579607 Geometric Symbols for Dimensioning and Tolerancing

H4/H8 Commercial and Government Entity (CAGE)

H6 Federal Item Name Directory for Supply Cataloging

H7 Manufacturers Part and Drawing Numbering Systems

DOD-STD-00100D(AR)

DOD 5220.22-M	DOD Industrial Security Manual for Safeguarding Classified Information
DOD 5230.25-PH	Control of Unclassified Technical Data with Military or Space Application
DODISS	Department of Defense Index of Specifications and Standards

(Copies of specifications, standards, handbooks, drawings, and publications required by contractors in connection with specific acquisition functions should be obtained from the contracting activity or as directed by the contracting officer.)

Other publications. The following documents form a part of this standard to the extent specified herein. Unless otherwise specified, the issues of the documents which are DoD adopted shall be those listed in the issue of the DoDISS specified in the solicitation. The issues of documents which have not been adopted shall be those in effect on the date of the cited DoDISS.

AMERICAN NATIONAL STANDARDS INSTITUTE (ANSI)

ANSI B46.1-85	Surface Texture (Surface roughness, waviness, and lay)
ANSI B92.1-70 w/B92.1a-76	Involute Splines and Inspection
ANSI B94.6-84	Knurling
ANSI X3.5-70	Flowchart Symbols and their Usage in Information Processing. Same as FIPS-24, Federal Information Processing Standards.
ANSI Y10.3-68	Letter Symbols for Quantities Used in Mechanics of Solids
ANSI Y10.20-75 w/ANSI Y10.20a-75	Mathematical Signs and Symbols for Use in Physical Sciences and Technology
ANSI Y14.1-80	Drawing Sheet Size and Format, Engineering Drawing and Related Documentation Practices
ANSI Y14.2M-79	Line Conventions and Lettering, Engineering Drawing and Related Documentation Practices
ANSI Y14.3-75	Multi and Sectional View Drawings, Engineering Drawings and Related Documentation Practices
ANSI Y14.5-73	Dimensioning and Tolerancing
ANSI Y14.5M-82	Dimensioning and Tolerancing
ANSI Y14.6-78	Screw Thread Representation
ANSI Y14.6AM	Metric Supplement

AMERICAN NATIONAL STANDARDS INSTITUTE (ANSI) (Cont'd)

ANSI Y14.7.1-71	Gear Drawing Standards, Part 1: for Spur, Helical, Double Helical, and Rack, Drafting Practices
ANSI Y14.7.2-78	Gear and Spline Drawing Standards - Part 2: Bevel and Hypoid Gears, Engineering Drawing and Related Documentation Practices
ANSI Y14.13M-81	Mechanical Spring Representation, Engineering Drawing and Related Documentation Practices
ANSI Y14.15-66	Electrical and Electronics Diagrams including Proposed USA Standards for Connection Diagrams and Technical Diagrams
ANSI Y14.15a-71	Interconnection Diagrams
ANSI Y14.15b-73	Supplement to ANSI Y 14.15-66 and ANSI Y14.15a-70
ANSI Y14.17-66	Fluid Power Diagrams
ANSI Y14.26.3-75	Dictionary of Terms for Computer-aided Preparation of Product Definition Data (Including Engineering Drawings), Engineering Drawing and Related Documentation Practices.
ANSI Y14.36-78	Surface Texture Symbols, Engineering Drawing and Related Documentation Practices
ANSI Y32.4-77	Graphic Symbols for Plumbing Fixtures for Diagrams Used in Architecture and Building Construction
ANSI Y32.9-72	Graphic Symbols for Electric and Layout Drawings Used in Architecture and Building Construction
ANSI Y32.10-67	Graphic Symbols for Fluid Power Diagrams
ANSI/AWS A2.4-79	Symbols for Welding and Nondestructive Testing
ANSI/IEEE 260-78	Letter Symbols for Units of Measurement (SI Units, Customary Inch-Pound Units, and Certain Other Units)
ANSI/IPC-D-350-77	Printed Board Description in Digital Form
ANSI/IPC-T-50C-85	Interconnecting and Packaging Electronic Circuits, Terms and Definitions for

DOD-STD-00100D(AR)

ANSI/SAE AS1290-75 Graphic Symbols for Aircraft Hydraulic and
Pneumatic System

ASTM

ASTM E380-84 Metric Practice, Standard for

AMERICAN WELDING SOCIETY, INC. (AWS)

AWS A3.0-85 Welding Terms and Definitions

THE INSTITUTE OF ELECTRICAL AND ELECTRONICS ENGINEERS, INC.

IEEE STD 91-84 Graphic Symbols for Logic Functions

IEEE STD 200-75 Reference Designations for Electric and
Electronics Parts and Equipment (Same as
ANSI Y32.16-1975)

IEEE STD 280-85 Letter Symbols for Quantities used in
Electrical Science and Electrical Engineering
(Same as ANSI Y10.5-1968)

IEEE STD 315-75 Graphic Symbols for Electrical and Electronics
Diagrams (including Reference Designation Class
Designation Letters). (Same as ANSI Y32.2-1975)

SOCIETY OF AUTOMOTIVE ENGINEERS, INC.

SAE HSJ1086-83/ Unified Numbering System, Metals and Alloys
ASTM DS56B

Order of precedence. In the event of a conflict between the text of this standard and the references cited herein, the text of this standard shall take precedence.

Source of documents.

Government specifications, standards, and handbooks. Copies of the referenced federal and military specifications, standards, and handbooks are available from the Department of Defense Single Stock Point, Commanding Officer, Naval Publications and Forms Center, 5801 Tabor Avenue, Philadelphia, PA 19120. For specific acquisition functions, these documents should be obtained from the contracting activity or as directed by the contracting officer.

Other Government documents. Copies of other government documents required by contractors in connection with specific acquisition functions should be obtained from the contracting activity or as directed by the contracting officer.

Sources for nongovernment publications. Nongovernment documents are generally available for reference from libraries and technical groups. The documents listed may be obtained as follows:

DOD-STD-00100D(AR)

- a. ANSI: Application for copies should be addressed to the American National Standards Institute, 1430 Broadway, New York, NY 10018.
- b. ASTM: Application for copies should be addressed to ASTM, 1916 Race Street, Philadelphia, PA 19103.
- c. AWS: Application for copies should be addressed to the American Welding Society, Inc., 2501 NW 7th Street, Miami, FL 33125.
- d. IEEE: Application for copies should be addressed to the Institute for Electrical and Electronics Engineers, Inc., 345 E. 47th Street, New York, NY 10017.
- e. IPC: Application for copies should be addressed to the Institute of Interconnecting and Packaging Electronic Circuits, 3451 Church Street, Skokie, IL 60076.
- f. SAE: Application for copies should be addressed to the Society of Automotive Engineers, Inc., 400 Commonwealth Drive, Warrendale, PA 15096.

DOD-STD-00100D(AR)

CONTENTS

<u>CHAPTER</u>		<u>PAGE</u>
100	Preparation of Engineering Drawing	100-1
200	Types of Engineering Drawings	200-1
300	Drawing Titles	300-1
400	Numbering, Coding, and Identification	400-1
500	Revision of Engineering Drawings	500-1
600	Associated Lists	600-1
700	Definitions (General)	700-1
Appendix A	Drawing format and supplementary blocks entries	A-1
Appendix B	Security classification marking and notations	B-1
Appendix C	Interpretation of dimensioning and tolerancing	C-1
Appendix D	Sample drawings	D-1
Appendix E	Revision of drawings	E-1
Appendix F	Commonly Used CAGE Codes	F-1
Appendix G	Initial/signature requirements	G-1
Appendix H	Marking and distribution statements for technical documents	H-1
Appendix I	Order of precedence for selection of standards and specifications	I-1
Appendix J	Index	J-1

DOD-STD-00100D(AR)

CONTENTS

<u>Para</u>	<u>Description</u>	<u>Page</u>
100	General	100-1
100.1	Definitions and requirements	100-1
101	Basic practices	100-1
101.1	Size and format of engineering drawings	100-1
101.1.1	Continuation Sheets	100-2
101.2	Line conventions and lettering	100-2
101.3	Multi and sectional view drawings	100-3
101.3.1	Isometric and pictorial views	100-6
101.4	Metric values	100-6
101.4.1	Application in new design	100-6
101.5	Dimensioning and tolerancing	100-6
101.6	Surface texture	100-13
101.6.1	Surface texture symbols	100-13
101.7	Screw thread representation	100-13
101.8	Gears	100-13
101.9	Mechanical springs	100-13
101.10	Optical elements and optical systems	100-13
101.11	Computer-aided preparation of product definition data	100-13
101.11.1	Computer-aided Design (CAD) drawings	100-13
101.11.2	Deviations from CAD	100-13
101.11.3	CAD line conventions variation	100-13
102	Graphic symbols, designations, letter symbols, and abbreviations	100-14
102.1	Graphic symbols	100-14
102.1.1	Graphic symbols for electrical and electronics diagrams	100-14
102.1.2	Graphic symbols for logic functions	100-14
102.1.3	Graphic symbols for flowchart diagrams	100-14
102.1.4	Graphic symbols for fluoric power diagrams	100-14
102.1.5	Graphic symbols for electrical wiring and layout diagrams used in architecture and building instruction	100-14
102.1.6	Mechanical symbols	100-14
102.1.6.1	Graphic symbols for plumbing fixtures	100-14
102.1.7	Mechanical symbols for aeronautical, aerospacecraft, and spacecraft use	100-15
102.1.7.1	Graphic symbols for aircraft hydraulic and pneumatic systems	100-15
102.1.8	Ship structural symbols	100-15
102.1.9	Architectural symbols	100-15
102.1.10	Electrical wiring equipment symbols for ships' drawings	100-15
102.1.11	Welding symbols	100-15
102.1.12	Nondestructive testing symbols	100-15
102.1.13	Graphic symbols for fluid power diagrams	100-16
102.2	Designations	100-16
102.2.1	Reference designations for electrical and electronics parts and equipment	100-16
102.3	Letter symbols and abbreviations	100-16
102.3.1	Letter symbols	100-16
102.3.2	Mathematical signs and symbols	100-16
102.3.3	Abbreviations	100-16

DOD-STD-00100D(AR)

CONTENTS (Cont'd)

<u>Para</u>	<u>Description</u>	<u>Page</u>
103	Diagrams	100-16
103.1	Electrical and electronics diagrams	100-16
103.2	Fluid power diagrams	100-16
103.3	Printed wiring drawings	100-16
103.3.1	Printed board description in digital form	100-16
104	Drawing material	100-16
104.1	Duplicate original	100-16
105	Security classification and notation	100-16
106	Scale	100-17
106.1	Selection of scale	100-17
106.2	Indication of scale	100-17
106.2.1	Fractional method	100-17
106.3	Drawings not to scale	100-17
106.4	Dimensions not to scale	100-17
107	Radioactive materials	100-17
108	Marking and marking location	100-17
108.1	Identification marking requirements	100-17
108.1.1	Drawing requirements	100-18
108.1.2	Matched parts	100-20
108.1.3	Markings other than part number identification	100-21
108.1.3.1	Rubber products	100-21
108.1.3.2	CARC painted item	100-21
108.1.3.3	Sensitive electronic device (SED) items	100-21
109	Optional/Alternative designs	100-22
110	Depiction of part	100-22
111	Module Data	100-23
112	Analog signal processing circuits	100-23
113	Digital signal processing circuits	100-23
114	Reference identifiers	100-24
115	Application block entries	100-24
116	Microcircuits	100-24
117	Drawing notes	100-25
117.1	Language style	100-25
117.2	Commonly used words and phrases	100-25
117.3	Use of "shall", "will", "should", and "may"	100-25
117.4	Indefinite terms	100-25
117.5	Location of notes	100-25
117.6	Note contents	100-26
118	Material notes	100-30
119	Signing and Dating Drawings	100-31
119.1	Dating drawings	100-31
119.1.1	Signing for another	100-31
119.1.2	Redrawn drawings	100-31
119.2	Dating drawings	100-31
119.3	Initial and signature block	100-32
119.4	Additional signatures	100-32
119.5	CAD prepared drawings	100-32
119.6	Microfilm aperture card signatures	100-32
200	General	200-1
201	Definitions and requirements	200-1

DOD-STD-00100D(AR)

CONTENTS (Cont'd)

<u>Para</u>	<u>Description</u>	<u>Page</u>
201.1	Engineering drawing	200-1
201.1.1	Application	200-1
201.1.2	Integral parts list	200-1
201.2	Detail drawing	200-1
201.2.1	Monodetail drawing	200-1
201.2.2	Multidetail drawing	200-2
201.2.3	Tabulated detail drawing	200-5
201.2.4	Tube bend drawing	200-6
201.3	Assembly drawing	200-8
201.3.1	Detail assembly drawing	200-10
201.3.2	Tabulated assembly drawing	200-11
201.3.3	Photo-assembly drawing	200-12
201.3.4	Inseparable assembly	200-12
201.3.5	Installation assembly drawing	200-14
201.3.6	Exploded assembly drawing	200-14
201.3.7	Matched parts drawing	200-14
201.3.8	Arrangement drawing	200-16
201.4	Control drawing	200-17
201.4.1	Envelope drawing	200-17
201.4.2	Specification control drawing	200-19
201.4.3	Source control drawing	200-22
201.4.4	Altered item drawing	200-26
201.4.5	Selected item drawing	200-28
201.4.6	Interface control drawing	200-30
201.4.7	Installation control drawing	200-31
201.5	Installation drawing	200-32
201.6	Elevation drawing	200-34
201.7	Diagrammatic drawing	200-35
201.7.1	Schematic diagram	200-35
201.7.2	Connection or wiring diagram	200-37
201.7.3	Interconnection diagram	200-38
201.7.4	Single-line or one-line diagram	200-40
201.7.5	Logic diagram	200-41
201.7.6	Mechanical schematic diagram	200-42
201.7.7	Piping diagram	200-43
201.8	Construction drawing	200-44
201.8.1	Erection drawing	200-44
201.8.2	Plan drawing	200-44
201.8.3	Plot (plat) plan drawing	200-46
201.8.4	Vicinity plan or site drawing	200-46
201.9	Special purpose drawing	200-46
201.9.1	Book-form drawing	200-46
201.9.2	Wiring list	200-53
201.9.3	Numerical control drawing	200-53
201.9.4	Optical elements and optical system drawings	200-55
201.9.5	Wiring harness drawing	200-55
201.9.6	Cable assembly drawing	200-57
201.9.7	Undimensional drawing	200-58

DOD-STD-00100D(AR)

CONTENTS (Cont'd)

<u>Para</u>	<u>Description</u>	<u>Page</u>
201.9.8	Printed wiring master (stable base artwork) pattern drawing	200-60
201.9.8.1.1	Digital form	200-60
201.9.9	Printed wiring master drawing	200-62
201.9.10	Kit drawing	200-64
201.9.10.2	Rework drawing requirement	200-65
201.9.10.3	Installation instruction drawing	200-66
201.9.11	Combinations of adopted items drawing	200-69
201.9.12	Ship equipment (marine item) drawing	200-71
201.9.12.2	Weight	200-71
201.9.12.3	Conformance with specification	200-71
201.9.13	Certification data sheet	200-73
201.9.13.1	Contents	200-73
201.9.14	Correlation drawing	200-75
201.9.15	Formulation drawing	200-75
201.9.16	Contour definition drawing	200-77
201.9.17	Modification drawings	200-77
201.10	Layout drawing	200-77
201.10.1	Application guidelines	200-77
201.11	Camouflage basis drawing	200-80
201.12	Camouflage pattern drawing	200-88
201.13	Vehicle drawing (top assembly)	200-94
201.14	Vehicle camouflage pattern drawing	200-94
201.15	Package content drawing	200-97
201.16	Software and Firmware data	200-99
201.16.1	Software control drawing	200-99
201.16.2	Firmware drawing	200-100
300	General	300-1
301	Definitions	300-1
301.1	Drawing title	300-1
301.2	Approved item name	300-1
301.3	Type designation	300-1
301.4	Assembly	300-1
302	Procedures for creating drawing titles	300-1
302.1	General rules	300-1
302.2	First part of title	300-2
302.3	Second part of title	300-4
303	Disclosure of security categories	300-5
304	Titles for kit drawings	300-5
400	General	400-1
401	Definitions	400-1
401.1	Referenced documents	400-1
401.2	Contractor and Government Entity Code (CAGE Code)	400-1
401.3	Document identification number	400-1
401.4	Drawing number	400-1
401.5	Part numbers	400-1
401.6	Find number	400-2
402	Identification requirements	400-2
402.1	New drawings and associated lists	400-2
402.2	Existing drawings and associated lists	400-2
402.3	Referenced documents	400-2

DOD-STD-00100D(AR)

CONTENTS (Cont'd)

<u>Para</u>	<u>Description</u>	<u>Page</u>
402.4	Contractor and Government Entity Code for Manufacturers	400-2
402.5	Drawing number	400-2
402.6	Part numbers	400-4
402.7	Records	400-5
402.8	Associated lists	400-5
402.9	Transferring design responsibility to another activity	400-5
402.9.1	Source control drawing	400-5
402.9.2	Maintaining design activities identities	400-6
402.9.3	Drawing with "00000" CAGE Code (CODE IDENT)	400-7
402.10	Item identification and part numbering	400-9
402.10.1	Reidentification	400-9
402.11	Identification on drawings	400-10
402.11.1	Specification control and source control drawings	400-12
402.11.2	Parenthetical identifier	400-12
402.12	CAGE Code and part numbering	400-12
402.13	Numbering of related parts	400-13
402.13.1	Matched parts designation	400-13
402.13.2	Symmetrically opposite parts	400-13
402.13.3	Inseparable assembly	400-13
402.14	Changes requiring new identification	400-13
402.15	Changes not requiring new identification	400-14
402.16	Identification of materials, processes and protective treatment	400-14
402.16.1	Group identification	400-14
402.16.2	Other identification	400-14
402.16.3	Formulation identification	400-14
402.16.4	Bulk materials identification	400-14
402.16.5	Identification of precious metals	400-16
402.16.6	Nuclear hardness critical items and processes	400-18
402.16.6.1	Items	400-18
402.16.6.2	Processes	400-18
402.16.6.3	Marking	400-18
402.16.7	Critical Safety Items	400-19
402.16.7.1	Critical Safety Item Drawing	400-19
402.16.7.1.1	Critical Safety Item Note	400-19
402.16.7.2	Critical Safety Item Assembly	400-20
402.16.8	Electrostatic Discharge Sensitive Items	400-21
402.17	Original date	400-23
402.18	Order of precedence of specifications and standards	400-23
402.19	Interface Control Identification Symbol	400-23
402.19.1	Location of symbol	400-23
402.20	Part replacement notation	400-24
402.20.1	Interchangeable parts	400-24
402.20.2	Non-Interchangeable parts	400-25
402.20.3	Obsoleted parts	400-26
402.20.4	Superseded parts	400-27
402.20.5	Notation size and location	400-28
402.21	Ordnance Engineering Standards (TAXI)	400-28

DOD-STD-00100D(AR)

CONTENTS (Cont'd)

<u>Para</u>	<u>Description</u>	<u>Page</u>
402.22	Identifying optional parts	400-28
402.23	Distribution Statement	400-28
402.24	Duplicate Original	400-29
500	General	500-1
501	Definitions	500-1
502	Revision methods	500-1
502.1	Change in dimensions	500-1
502.2	Crossing out	500-1
502.3	Drawing practices	500-1
503	Identifying revisions on drawings	500-1
503.1	Identifying revision location	500-1
503.2	Revision letters	500-1
503.3	Multiple changes	500-1
503.4	Additions	500-2
503.5	Change in rights to technical data	500-2
503.6	Required revisions	500-3
504	Recording revisions on drawings	500-3
504.1	Revision block	500-3
504.1.1	Letter	500-3
504.1.2	Description	500-3
504.1.3	Approval	500-3
504.1.4	Zoning	500-3
504.1.5	Revision date	500-3
504.1.6	Separating revisions	500-3
505	Revision of multi-sheet and book-form drawings	500-4
505.1	Procedure	500-4
505.2	Adding sheets to multi-sheet and book-form drawings	500-4
505.3	Deleting sheets from multi-sheet and book-form drawings	500-4
505.4	Computer-generated/revise drawings	500-6
506	Redrawn or replaced drawings	500-6
507	Reinstating a replaced/superseded/obsoleted drawing	500-10
508	Associated List(s) revisions	500-10
509	Identification of Configuration Management Baseline	500-10
600	General	600-1
601	Definitions	600-1
601.1	Parts list (PL)	600-1
601.2	Parts list requirement	600-1
602	General requirements	600-1
602.1	List preparation	600-1
602.1.1	Manual preparation	600-1
602.1.2	Automatic data processing system (ADPS) preparation	600-3
602.2	Multiple sheets	600-5
602.2.1	Sheet numbering	600-5
602.2.2	Legibility requirements	600-5
602.2.3	List maintenance	600-5
602.3	Revisions	600-5
602.3.1	Revision identification	600-5
602.3.2	Deleting items	600-5

DOD-STD-00100D(AR)

CONTENTS (Cont'd)

<u>Para</u>	<u>Description</u>	<u>Page</u>
602.3.3	Adding items	600-5
602.3.4	Revision description	600-5
602.4	Design activity identification	600-5
602.5	Block and column size and arrangement	600-5
602.6	Additional blocks and columns	600-5
603	Parts list preparation	600-5
603.1	Format	600-5
603.2	Entries	600-6
603.2.1	Block 1, Design Activity Identification	600-6
603.2.2	Block 2, CAGE Code	600-6
603.2.3	Block 3, Original Date	600-6
603.2.4	Block 4, Parts List Number	600-6
603.2.5	Block 5, List Title	600-6
603.2.6	Block 6, Authentication Signature	600-6
603.2.7	Block 7, Sheet Number	600-6
603.2.8	Block 8, Drawing Number	600-6
603.2.9	Column 9, Find Number	600-6
603.2.10	Column 10, Quantity Required	600-7
603.2.11	Column 11, CAGE Code	600-7
603.2.12	Column 12, Part or Identifying Number	600-7
603.2.13	Column 13, Drawing Size	600-7
603.2.14	Column 14, Drawing/Document Number	600-8
603.2.15	Column 15, Nomenclature or Description	600-9
603.2.16	Column 16, Supplemental List	600-9
603.2.17	Column 17, Notes	600-9
603.2.18	Block 18, Revision Letter/Description/Date/Approval	600-9
603.2.19	Revision Letter/Date/Approval of ADPS Prepared Lists	600-10
604	On Vehicle Equipment List (OVE)	600-10
604.1	Basic Issue Items (BII)	600-10
604.2	Additional Authorized List (AAL)	600-10
605	Special Tool Set List	600-10
605.1	Special Tool Sets	600-10

DOD-STD-00100D(AR)

LIST OF ILLUSTRATIONS

<u>FIGURE</u>	<u>ILLUSTRATIONS</u>	<u>PAGE</u>
100-1	Lettering Sizes	100-3
100-2	Auxiliary and Sectional View	100-4
---	Rotation From Perpendicular	
---	Projection	
100-3	Locations of Views/Sections	100-4
100-4	Positioning Requirements	100-5
100-5	Angle Projection Symbols	100-5
100-6	Tabular Dimensioning Method	100-8
100-7	Tabular Dimensioning Method	100-9
---	(Circular Part)	
100-8	Interpretation of Dimensions Shown to	100-11
---	Implied Intersections	
100-9	Example of Drawing Requirement for Edge Radius	100-12
100-10	Permissible Variation in Part Configuration	100-12
100-11	Example of Radiographic Position Diagram	100-15
100-12	Sample Microfilm Aperture Card Signature/ Revision Block	100-33

200-1	Monodetail drawing	200-2
200-2	Multi-detail drawing	200-3
200-3	Tabulated detail drawing	200-5
200-4	Tube bend drawing	200-6
200-5	Tube bend drawing	200-7
200-6	Assembly drawing	200-9
200-7	Detail assembly drawing	200-10
200-8	Tabulated assembly drawing	200-11
200-9	Inseparable assembly drawing	200-13
200-10	Matched parts drawing	200-15
200-11	Arrangement drawing	200-16
200-12	Envelope drawing	200-18
200-13	Specification control drawing	200-21
200-14a	Source control drawing (with replaceable parts)	200-24
200-14b	Source control drawing (replacement part)	200-25
200-15	Altered item part (part controlled by Military Standard)	200-26
200-16	Selected item drawing (part controlled by Military Standard)	200-29
200-17	Interface control drawing	200-30
200-18	Installation control drawing	200-31
200-19	Installation drawing	200-33
200-20	Elevation drawing	200-34
200-21	Schematic diagram drawing	200-36
200-22	Connection or wiring diagram drawing	200-37
200-23a	Interconnection diagram drawing (cabling type)	200-38
200-23b	Interconnection diagram	200-39
200-24	Single-line diagram drawing	200-40
200-25	Logic diagram drawing	200-41
200-26	Mechanical schematic diagram drawing	200-42
200-27	Piping diagram drawing	200-43
200-28	Plan drawing	200-45

DOD-STD-00100D(AR)

LIST OF ILLUSTRATIONS (Cont'd)

<u>FIGURE</u>	<u>ILLUSTRATION</u>	<u>PAGE</u>
200-29a	Book-form drawing (Title sheet)	200-47
200-29b	Book-form drawing (Continuation sheet)	200-48
200-29c	Book-form drawing (Continuation sheet)	200-49
200-29d	Book-form drawing (List of Units)	200-50
200-29e	Book-form drawing (Cable wiring sheet)	200-51
200-29f	Book-form drawing (Wiring List)	200-52
200-30	Numerical control drawing	200-54
200-31	Wiring harness drawing	200-56
200-32	Cable assembly drawing	200-57
200-33	Undimensioned drawing	200-59
200-34	Printed wiring master pattern drawing	200-61
200-35	Printed wiring master drawing (board detail)	200-63
200-36	Installation instruction drawing	200-68
200-37	Combination of adopted items drawing	200-70
200-38	Ship equipment (marine item) drawing	200-72
200-39	Certification data sheet	200-74
200-40	Formulation drawing	200-76
200-41	Layout drawing	200-79
200-42	Camouflage basis drawing	200-81
200-43	Camouflage pattern drawing	200-89
200-44	Vehicle drawing (top assembly)	200-95
200-45	Vehicle camouflage pattern drawing	200-96
200-46	Package content drawing	200-98
200-47	Software control drawing	200-99
200-48	Altered item drawing (Firmware)	200-100
400-1	Example of CAGE Code, Drawing No., Design Activity Relationship as originally specified	400-3
400-2	Example of Drawing Notation when Design Responsibility is Transferred	400-6
400-3a	Example of Drawing Entries when Redrawn after Design Responsibility was Transferred	400-6
400-3b	Example of "00000" CAGE Code (CODE IDENT) prior to change	400-7
400-3c	Example of change to the current CAGE Code of the original design activity	400-7
400-3d	Example of change to the current CAGE Code of the original design activity	400-8
400-4	Precious Metals Indicator Code	400-17
400-5	Radiation Hardness Assurance (RHA) Level	400-18
400-6	Sensitive electronic devices (SED) symbol	400-21
400-6a	Alternative Sensitive electronic devices (SED) symbol	400-21
400-7	Example of Interchangeable Parts Notation	400-24
400-8	Example of Non-Interchangeable Parts Notation	400-25
400-9	Example of Obsolete Notation	400-26
400-10	Example of Superseded Notation	400-27
400-11	Example of Duplicate Original Notation	400-29
500-1	Example of Revision Block Notation for Multi-Sheet Drawing	500-2
500-2	Example of Revision Block Notation for Changes in Drawing Rights	500-2

DOD-STD-00100D(AR)

LIST OF ILLUSTRATIONS (Cont'd)

<u>FIGURE</u>	<u>ILLUSTRATIONS</u>	<u>PAGE</u>
500-3	Typical change and effect on revision status block and revision status of drawing sheets (1 through 5)	500-5
500-4	Revision status to existing drawings	500-5
500-5	Superseding (new) Drawing Notations Redrawn with Same Number	500-6
500-6	Superseded (old) Drawing Notations Redrawn with Same Number	500-7
500-7	Superseding (new) Drawing Notations Replacing Drawing with Different Number	500-8
500-8	Superseded (old) Drawing Notations Replaced by Drawing with Different Number	500-9
500-9	Example of Notation for Allocated Baseline	500-10
500-10	Example of Notation for Product Baseline	500-10
600-1	Manually Prepared Parts List Format	600-2
600-2	Sample Format for Automatic Data Processing System (ADPS) Prepared Parts List	600-3
600-3	Example of ADPS Prepared Parts List	600-4

23

DOD-STD-00100D(AR)

LIST OF ILLUSTRATIONS (Cont'd)

<u>FIGURE</u>	<u>ILLUSTRATIONS</u>	<u>PAGE</u>
<u>APPENDIX A</u>		
A-1	Drawing Format and Supplementary Blocks Entries	A-2
A-2	Title/Revision/Supplementary Block Entries	A-3
A-3	CAD Generated Microfilm Approval Blocks Format	A-4
A-4	Integral parts lists (format and location)	A-5
A-5	Drawing Format for B size and larger	A-6
A-6	Drawing Format for A size	A-7
A-7	Drawing Format for A size continuation sheet	A-8
A-8	Drawing Format for Book-form drawing (Title sheet)	A-9
A-9	Drawing Format for Combination of Adopted Items drawing	A-10
A-9	Drawing Format for Package Contents drawing	A-10
<u>APPENDIX B</u>		
B-1	Security classification markings and notations	
B-1	Location of Security Markings on Drawings	B-4
B-2	Location of Security Markings on Roll Size Drawings	B-4
B-3	Location of Security Markings on Associated Lists	B-5
B-4	Location of Security Markings on Computer Generated Associated Lists	B-5
B-5	Location of Security Markings on Book-Form Drawings	B-6
B-6	Regrading Classification Location	B-7
<u>APPENDIX C</u>		
C-1	Drawing changes to previously released drawings	
C-1	Dimensioning and tolerancing matrix	C-2
<u>APPENDIX D</u>		
D-1	Sample drawings	
D-1	Spring, Compression	D-2
D-2	Assembly (with Find Numbers)	D-3
D-3	Spring, Compression	D-4
D-4	Spring, Torsion	D-5
D-5	Radioactive material drawing	D-6
D-6	Interface control drawing	D-7
D-7	Electronic Assembly (with Hardness Critical Items)	D-8
D-8	Apparatus List	D-9
D-9	Vehicle drawing (top assembly)	D-10
D-10	Altered item drawing	D-11
D-11	Printed wiring hole location drawing	D-12
D-12	Specification control drawing	D-18
D-13	Specification control drawing	D-19
D-14	Radioactive assembly drawing	D-20
D-15	Involute Spline Data Drawing	D-21
D-16	Spur Gear Data Drawing	D-22
D-17	Spur Gear Data Drawing	D-23
D-18	General requirements drawing	D-24
D-19	Interface control drawing	D-25
D-20	Photo assembly drawing	D-26
D-21	Rework drawing	D-27
D-22	Cable assembly drawing	D-28
D-23	Modification drawing (before)	D-29
D-24	Modification drawing (after)	D-30
D-25	Altered item drawing	D-31

DOD-STD-00100D(AR)

LIST OF ILLUSTRATIONS (Cont'd)

<u>FIGURE</u>	<u>ILLUSTRATION</u>	<u>PAGE</u>
D-26	Altered item drawing	D-32
D-27	Selected item drawing	D-33
D-28	Altered item drawing/part controlled by Source Control Drawing)	D-34
D-29	Source control drawing	D-35
D-30	Wiring diagram	D-36
<u>APPENDIX E</u>		
E-1	Revision of drawings Example of Recording Revisions in accordance with METHOD A	E-4
E-2	Example of Recording Revisions in accordance with METHOD B	E-5
E-3	Example of Recording Revisions in accordance with METHOD C	E-6
E-4	Example of Recording Revisions in accordance with METHOD D	E-7
E-5a	Example of Recording Revisions for Formal Engineering Change Control in accordance with METHOD E	E-9
E-5b	Example of Recording Product Baseline and Revisions in accordance with METHOD E	E-9
E-6	Example of Recording Revisions in accordance with METHOD F	E-10
E-7	Example of Recording Revision on manually prepared parts list	E-11
<u>APPENDIX F</u>		
	Commonly used CAGE Codes	F-2
<u>APPENDIX G</u>		
G-1	Initial/Signature Requirements Initial/Signature Requirements	G-2
<u>APPENDIX H</u>		
	Marking and distribution statements for technical documents	
H-1	Distribution Statement location for "A" size format	H-4
H-2	Distribution Statement location for "A" size continuation sheet	H-5
H-3	Distribution Statement location for "B" size format	H-6
H-4	Distribution Statement location for C, D, E, F, H and K size format	H-7
H-5	Distribution Statement location for ADPS prepared parts lists	H-8
H-6	Distribution Statement location for manually prepared parts lists	H-9

DOD-STD-00100D(AR)

THIS PAGE LEFT BLANK INTENTIONALLY

26

DOD-STD-00100D(AR)

CHAPTER 100
PREPARATION OF ENGINEERING DRAWINGS

100 General. This chapter lists standards used for the preparation of Level 3 engineering drawings in accordance with DOD-D-1000. It is essential that drawings possess the following adequacy requirements for competitive procurements: Detail, subassembly, and assembly drawings shall completely delineate directly or by reference to other documents, engineering requirements and characteristics such as materials, dimensions, tolerances, form and finish. The requirements and characteristics shall also include, as applicable, any electrical, mechanical performance, and other requirements necessary for function and interchangeability. Requirements and characteristics for all drawings required to be delivered shall be sufficiently complete and detailed to enable the Government to perform engineering approval design evaluation, acceptance, inspection, and installation. These drawings shall also contain sufficient data to enable the Government or its contractors to competitively procure or reprocurve the like items.

100.1 Definitions and requirements. Definitions for words and terms marked with an asterisk (*) are located in Chapter 700.

101 Basic practices.

101.1 Size and format of engineering drawings. Engineering drawing sheet size and format shall be in accordance with ANSI Y14.1 except:

a. **Title block.** The title block shall be as shown in Appendix A. The title block is required on continuation sheets. Exception is, that a title block is not required on continuation sheets for book form drawings.

b. **"A" size format.** "A" size format shall be used for book form and word type drawings only.

c. **"J" size format.** "J" size format shall not be used.

d. **Supplemental drawing number blocks.** K size drawings shall have the drawing number, frame number, and revision letter entered in the appropriate blocks for multiframe microfilming as shown below. Sheet numbers shall be entered only on multiple sheet drawings. Size of blocks shall be in accordance with ANSI Y14.1. Starting direction from right or left requires prior approval of the Government Design Activity.

DWG NO. XXXXXXXX	SH 1	REV A	FRAME 1 OF 3
---------------------	---------	----------	-----------------

(1) K size drawings shall have a 2.00 margin minimum on each end with the drawing number (and sheet number for multiple sheet documents) entered on opposite ends so as to be readable when the drawings are rolled from either end and stored.

DOD-STD-00100D(AR)

e. Mechanical properties block. A mechanical properties block, when required by the Government Design Activity, shall be included on the drawing as shown in APPENDIX A.

f. Revision block. The revision block shall be as shown in APPENDIX A for all drawings. (See para 504.1.)

g. Application block. An application block shall be included on the drawing as shown in APPENDIX A.

101.1.1 Continuation sheets. Continuation sheets of multi-sheet drawings shall always be the same size as sheet one (1) except for roll size; the lengths may vary.

101.2 Line conventions and lettering. Line conventions and lettering shall be in accordance with ANSI Y14.2M except as follows and shall be capable of meeting the requirements of MIL-D-5480 except:

a. Lead type. Drawings shall be prepared using black plastic or plastic carbon combination type lead or ink.

b. Lettering and/or Numerals. Letters and numbers shall be vertical and applied using guides, templates or machines. Sizes (letter height) shall conform to those shown in FIGURE 100-1. All letters and numbers on the same drawing shall be of uniform size. Alpha and numeric characters that are similar, shall be readily distinguishable to the reader. Notations that contain a combination of alpha-numeric characters which could be misinterpreted, shall be shown as follows:

(1) Letter I shall be shown as "I", not "l".

(2) Letter O shall be shown as "O" not "Ø", "⊘", or "ϕ".

(3) Letter Z shall be shown as "Z", not "2".

(4) Numeral zero shall be slashed. The symbol used when slashed shall be square or oval and not round.

i.e. ⊘ ⊘
 Acceptable as
 a zero

ϕ
 Not acceptable
 as a zero

DOD-STD-00100D(AR)

- (5) Typewritten characters are permissible where indicated. Size shall be .10 minimum, maximum shall be as indicated.

APPLICATION	LETTERING SIZE DRAWING SIZE	
	A, B,	C, D, E, F, K
DRAWING NO.	.24-.25	.24-.31
PART NO.	.19-.25	.24-.25
DWG TITLES, CALLOUTS	.19-.25(1)	.24-.25
SUPPLEMENTARY DATA BLOCK ENTRIES	.19-.25(1)	.24-.25
DIMS, NOTES, REV	.14-.16(1)	.16-.19
"SECTION" "VIEW" "DETAIL"	.14-.16(1)	.19-.25
"A-A", "B"	.19-.25(1)	.24-.25

FIGURE 100-1. Lettering Sizes

c. Typewriter ink. Typewriter ink shall be prevented from penetrating the matte finish or mylar. It is recommended that Pounce No. 58-0690, Keuffel and Esser Company, or equivalent, be applied to the drawing immediately after typing.

29
d. Photo copies (Silver image copy wash off). The use of a reprographic processing system in the preparation of original engineering documentation is acceptable with prior approval of the Government Design Activity. When this method is employed, the documentation generated shall be regulated by established requirements for original drawings including reproducibility and microfilming. Material used shall be in accordance with applicable requirements specified in paragraph 104.

101.3 Multi and sectional view drawings. Multi and sectional views as shown on engineering drawings shall be in accordance with ANSI Y14.3 except:

a. Auxiliary and sectional views. Auxiliary and sectional views shall not be rotated from perpendicular projection except when unavoidable. When rotation of a view becomes necessary, the degree and direction of rotation shall appear beneath the view identification. See FIGURE 100-2.

DOD-STD-00100D(AR)

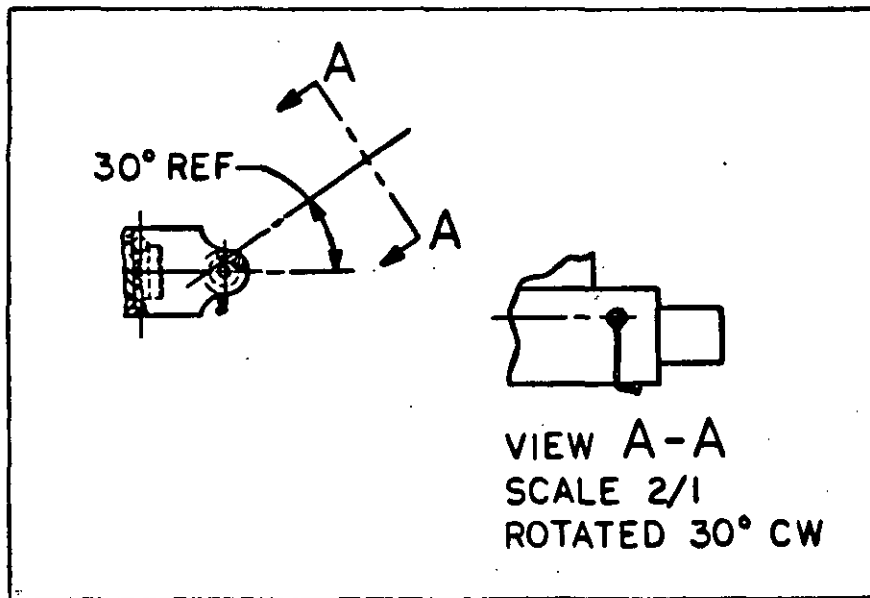

FIGURE 100-2. Auxiliary and Sectional View Rotation From Perpendicular Projection

b. Identification and location of views and sections. If two or more views and/or sections appear on the same sheet, they are to be arranged in alphabetical order from left to right. If views and/or sections are located on different sheets, from where taken, cross reference locations shall be indicated. See FIGURE 100-3.

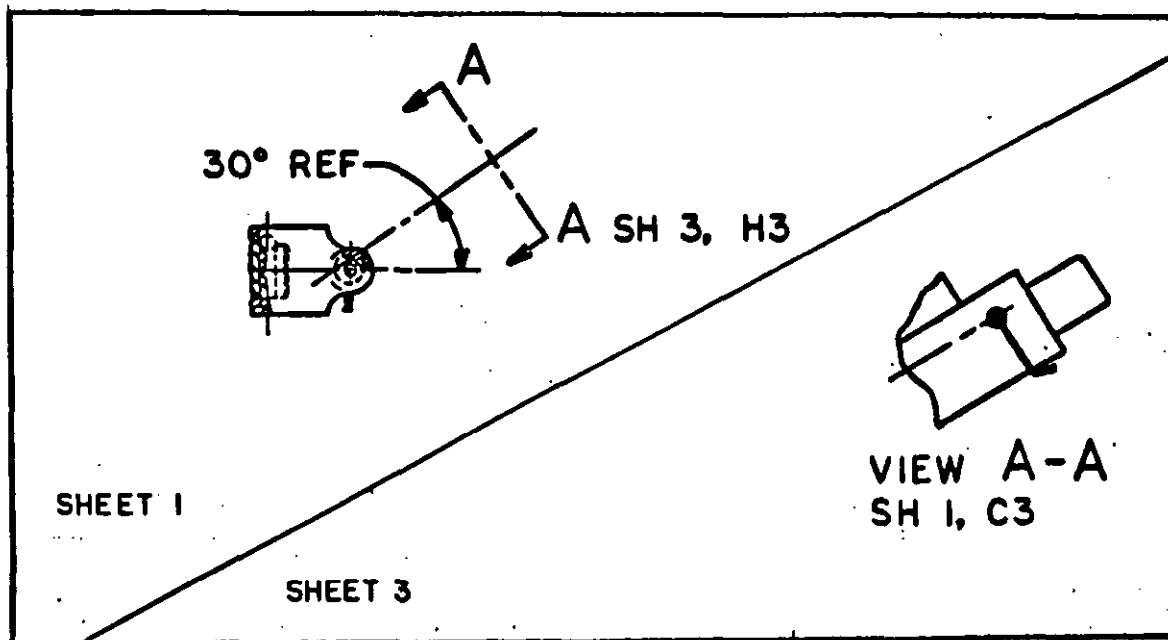

FIGURE 100-3. Location of Views and/or Sections

DOD-STD-00100D(AR)

c. Positioning of items. Items shall be positioned in accordance with pointing direction specified in FIGURE 100-4.

ITEM	POINTING DIRECTION
Artillery	Right
Artillery Ammunition	Right
Bombs	Left
Guided Missiles	Left
Jatos	Right
Pyrotechnics	Left
Rockets	Right
Small Arms	Right
Small Arms Ammunition	Right
Vehicles	Left

FIGURE 100-4. Positioning Requirements

d. Angle projection symbol. The symbol for third and/or first angle projection shall be shown on drawings and so labeled, when required, as follows:

- (1) Dual dimensioned drawings shall specify the angle of projection.
- (2) Metric dimensioned drawings shall specify the angle of projection.
- (3) Decimal inch dimensioned drawings shall specify the angle of projection if other than third angle.

Projection	Symbol
First angle	
Third angle	

FIGURE 100-5. Angle Projection Symbols

DOD-STD-00100D(AR)

101.3.1 Isometric and pictorial views. Isometric, pictorial, etc., views may be shown on engineering drawings providing there is some particular advantage and clarity is not degraded.

101.4 Metric values. Metric values, when used on engineering drawings, shall be in accordance with ASTM E380 and the following.

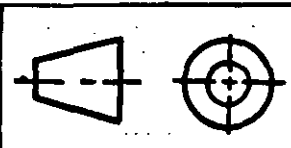
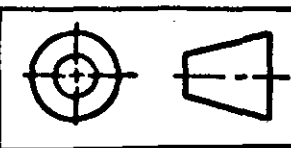
a. Paragraph 4.5, method B, of ASTM E380 shall be used in converting and rounding off decimal numbers to metric. The exact relation, 1 inch = 25.4MM applies.

b. When metric values are used on drawings, the following applies:

(1) The following note shall be specified:

"ASTM E380 APPLIES. METHOD B SHALL BE USED IN CONVERTING AND ROUNDING OFF. 1 INCH = 25.4 MM APPLIES."

(2) The symbol " METRIC " shall be shown adjacent to the title block in .25 high lettering.

101.4.1 Application in new design. The application of the metric system in new design shall be in accordance with the requirements of DOD-STD-1476.

101.5 Dimensioning and tolerancing. Dimensioning and tolerancing shall be in accordance with ANSI Y14.5M-1982 except for the following: (Pages and paragraph numbers referenced are from ANSI Y14.5M-1982.)

a. Where fitting at assembly, selective assembly or locating holes at assembly is required, the detail of each component shall clearly denote the specific dimension or dimensions of features which will require fitting, selection, or qualification at assembly. In addition, the fitting or selection criteria shall be indicated, e.g., "LOCATE WITH Part No. AT ASSEMBLY" shall be used to establish alignment and location of holes between two or more parts. Dimensions shall be specified on the pertinent assembly drawing.

b. Dimensions and tolerances shall be selected to assure that buildup of maximum tolerances will not cause functional or assembly difficulties. Tolerances shall be as liberal as possible, consistent with assembly, functional, and reliability requirements, but under no circumstances shall the desirability of maximizing tolerance limits on a component be permitted to compromise the feasibility of assembly and adjustments, or to compromise performance requirements of the assembled item.

c. The terms "ADVISORY" and "TYPICAL" shall not be used in conjunction with any dimension or tolerance.

d. Page 29, Para 3.2, Use of Notes to Supplement Symbols. The symbology system shall be used. Notes may be used to supplement a geometric requirement, but shall not be used in place of symbols.

e. Page 3, Para 1.4(h), Fundamental Rules. Except for electrical wire, when gage or code numbers are shown on drawings, they shall be defined by linear dimensions and identified by gaging system.

For example, (BS) Brown and Sharpe shall be shown as "BS GAGE 18 (.0403)"
(AWG) American Wire Gage shall be shown as "AWG 22 (.0253)"

DOD-STD-00100D(AR)

f. Page 7, Para 1.7.6, Reference Dimensions. Reference dimensions or reference data shall be labeled "REF". Enclosing references within parenthesis shall not be used.

g. Page 20, Para 2.4.1, Plated or Coated Parts:

(1) Inorganic Coatings. Dimensional limits and surface texture requirements normally apply after the application of inorganic type coatings such as electroplated or chemically displaced metals, ceramic, anodized, chromated, or oxide conversion type finishes, etc.

(2) Organic Coatings. Dimensional limits and surface texture requirements normally apply before the application of organic type coatings such as paint, lacquer, varnishes, enamels, phosphate coating, dry film lubricants, or other non-integral barrier-type coatings. When both types (organic and inorganic type) are complemented by an enamel or other top coating, the dimensional and surface texture requirements would apply after initial surface treatment.

(3) Drawing Requirements. Unless specified in applicable specifications and standards, drawings shall contain requirements as part of the protective finish note regarding dimensional and surfaces texture requirements, e.g.:

"DIMENSIONAL LIMITS AND SURFACE TEXTURE APPLY WITH PLATING."

"DIMENSIONAL LIMITS AND SURFACE TEXTURE APPLY WITHOUT PAINT."

"DIMENSIONAL LIMITS AND SURFACE TEXTURE APPLY WITH PLATING AND WITHOUT PAINT."

"DIMENSIONAL LIMITS AND SURFACE TEXTURE APPLY WITHOUT PLATING."

h. Page 19, Para 2.1.1, Application. General Tolerance block shall not be used for angular tolerance. Angular tolerances shall be shown on the body of the drawing with each angle specified.

DOD-STD-00100D(AR)

i. Page 20, Para 2.2 (b), Plus and Minus Tolerance. Linear tolerances shall be specified as shown in the following examples: For 45 degree angles, the tolerance shall be specified as \pm , e.g. $45^\circ \pm 4^\circ$, not $43^\circ + 4^\circ$, or $47^\circ - 4^\circ$.

<u>NOT ACCEPTABLE</u>	<u>ACCEPTABLE</u>		
.25 +.01 -.0	.25 \pm .01	.25+.01	.250-.005
.25 +.0 -.01	<i>.25 with number of places to agree with those for tolerances shown in general tolerance block.</i>		
.250+.000 -.010	.250+.010 -.005	.25-.01	

j. Page 35, Para 4.2, Datum Features. Features that are selected as datums shall, be clearly defined and recognizable. To be useful, a datum shall be accessible on the finished item and shall be a feature preferably with a small tolerance.

k. Page 16, Para 1.9, Location of Features. When tabular dimensioning methods are used to locate a large number of similarly shaped features on an item having mutually perpendicular planes, the method depicted in FIGURE 100-6 may be used. If the part does not have readily identifiable planes which can be considered mutually perpendicular, as, for example, a circular part, such planes, shall be established by note or symbol and the origin of measurement considered to be at the intersection of the planes so established. The direction of measurement shall be clearly indicated, as in FIGURE 100-7.

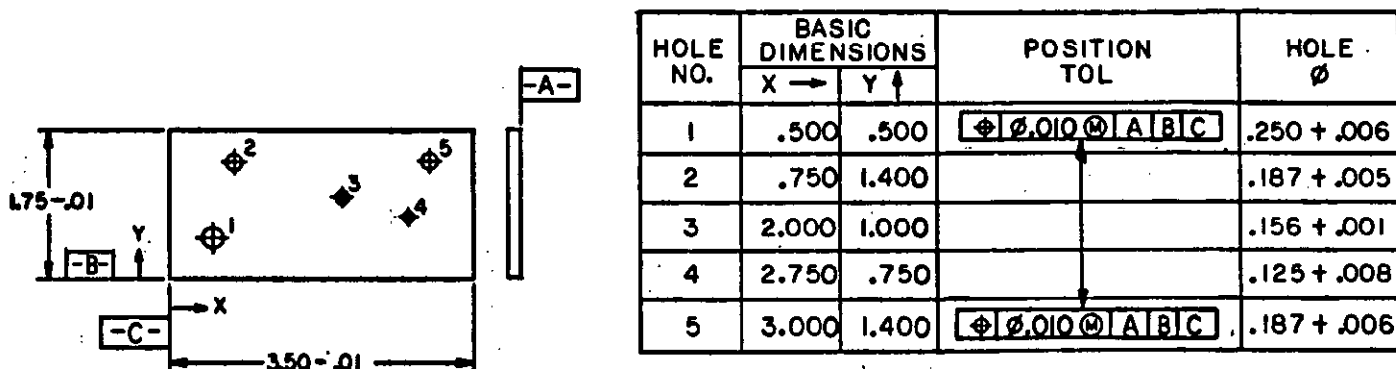

FIGURE 100-6. Tabular Dimensioning Method

1. Page 13, Figure 35, Slotted Holes. Method (b) as illustrated is not acceptable and shall not be used.

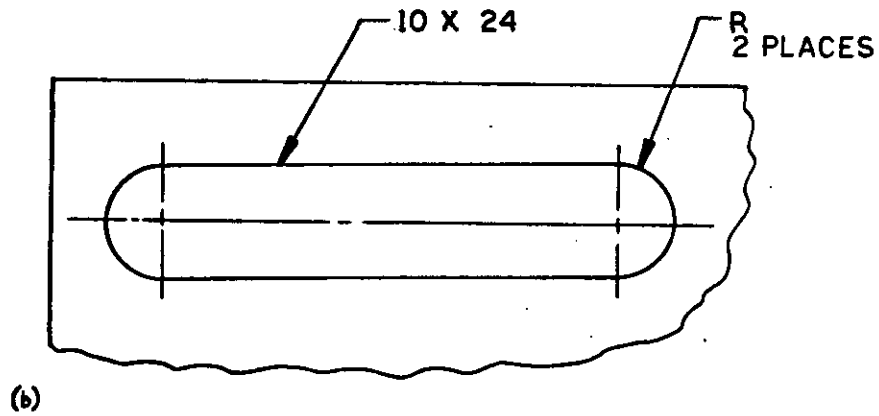
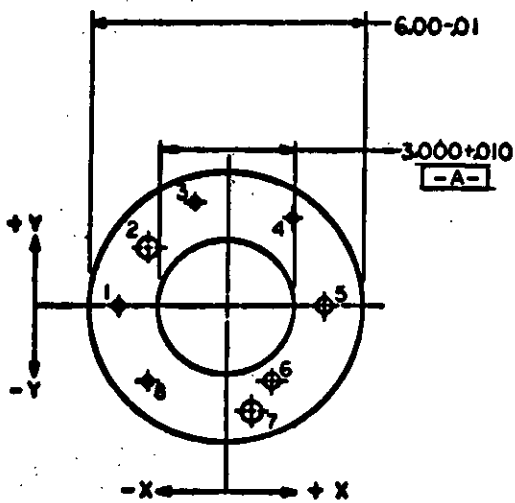

FIG. 35 SLOTTED HOLES



HOLE NO.	BASIC DIMENSIONS				POSITION TOL	HOLE Ø
	+X	-X	+Y	-Y		
1	—	2.500	—	—	⊕ ⌀.010 Ⓜ A Ⓜ	.250 +.007
2	—	1.820	1.360	—		.500 +.006
3	—	.750	2.400	—		.250 +.007
4	1.480	—	2.060	—		.250 +.002
5	2.250	—	—	—		.375 +.006
6	1.480	—	—	1.720		.375 +.008
7	.600	—	—	2.450		.500 +.005
8	—	1.820	—	1.720		⊕ ⌀.010 Ⓜ A Ⓜ

FIGURE 100-7. Tabular Dimensioning Method (Circular Part)

m. Page 4, Para 1.7 Application of dimensions. Dimensions shall not be shown to hidden features. Another view, sectional view or broken out section, shall be used.

i.e.

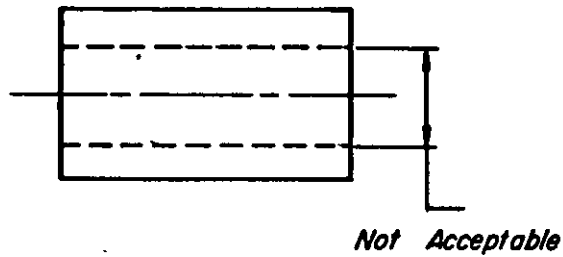
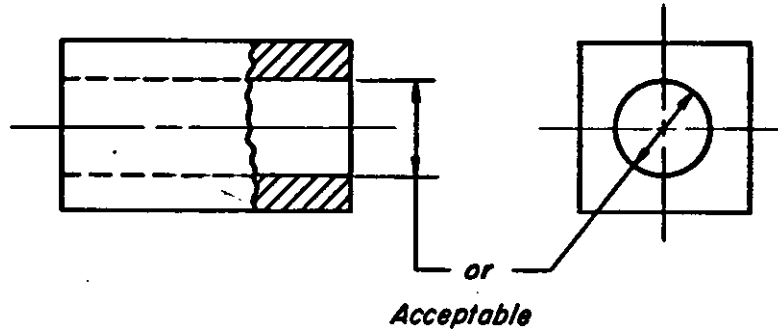

n. Page 7, Para 1.7.8 Dimensioning Within the Outline of a View. Dimensions shall always be placed outside the outline. Dimension, extension, or leader lines shall be arranged to keep them as short as practicable.

36

DOD-STD-00100D(AR)

O. Conversion of old dimensioning and tolerancing standards to ANSI Y14.5M-1982. When preparing new drawings (new numbers) from old originals using the Photo Copy System, updating the dimensioning and tolerancing system to ANSI Y14.5M-1982 will require the prior approval of the Government Design Activity. The same standard shall be used throughout a drawing. An appropriate notation shall be made. See paragraph 118.6x. If ANSI Y14.5-1973 is applicable, the following exceptions shall apply. Paragraph numbers are from ANSI Y14.5-1973.

(1) Para 5-1.11.1.1, Indicating Diameter. Only the diameter symbol will be used. The symbol will also be used when the feature is shown as a diameter and will follow the value.

(2) Para 5-1.10.5; Reference Dimensions. Only the abbreviation "REF" shall be used.

(3) Para 5-2.12, Indicating MMC or RFS. The requirements of RULE 2 apply. "MMC" or "RFS" will always be specified.

(4) Para 5-3.4.2 and FIGURE 9, Feature Control Symbol Incorporating Datum References. Only the method identified as the "usual sequence" in FIGURE 79 will be used.

(5) Para 5-1.8.4, Dual Linear Units. Dual linear units (Inch and Metric units) will be shown only when specifically directed by the Government Design Activity. See 101.4, Metric Values.

(6) Para 5-6.7.2, Types of Runout Control. All runout feature control symbols shall include the type of runout control required. Either the term "CIRCULAR" or "TOTAL" shall be entered below the feature control symbol. On drawings where there are numerous runout control symbols, a note such as "UNLESS OTHERWISE SPECIFIED, ALL RUNOUT CONTROLS ARE .001" may be used instead of individual entries.

P. Implied intersection. Unless otherwise specified, dimensions shown to implied intersections of features, as illustrated in FIGURE 100-8, shall be interpreted as applying to the theoretical intersection of the surfaces.

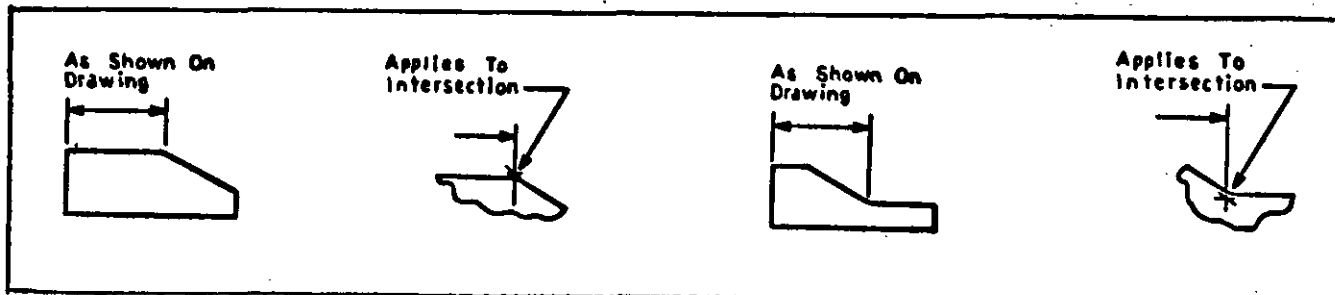

FIGURE 100-8. Interpretation of Dimensions Shown to Implied Intersection.

DOD-STD-00100D(AR)

r. Interior and/or exterior radius. Requirements for interior and/or exterior radius may be specified as shown in example FIGURE 100-9.

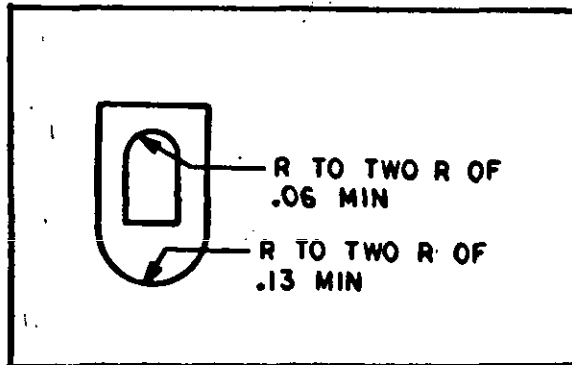

FIGURE 100-9. Example of Drawing Requirement for Edge Radius.

s. Variation in Configuration. Permissible variation in part configuration shall be as shown in FIGURE 100-10.

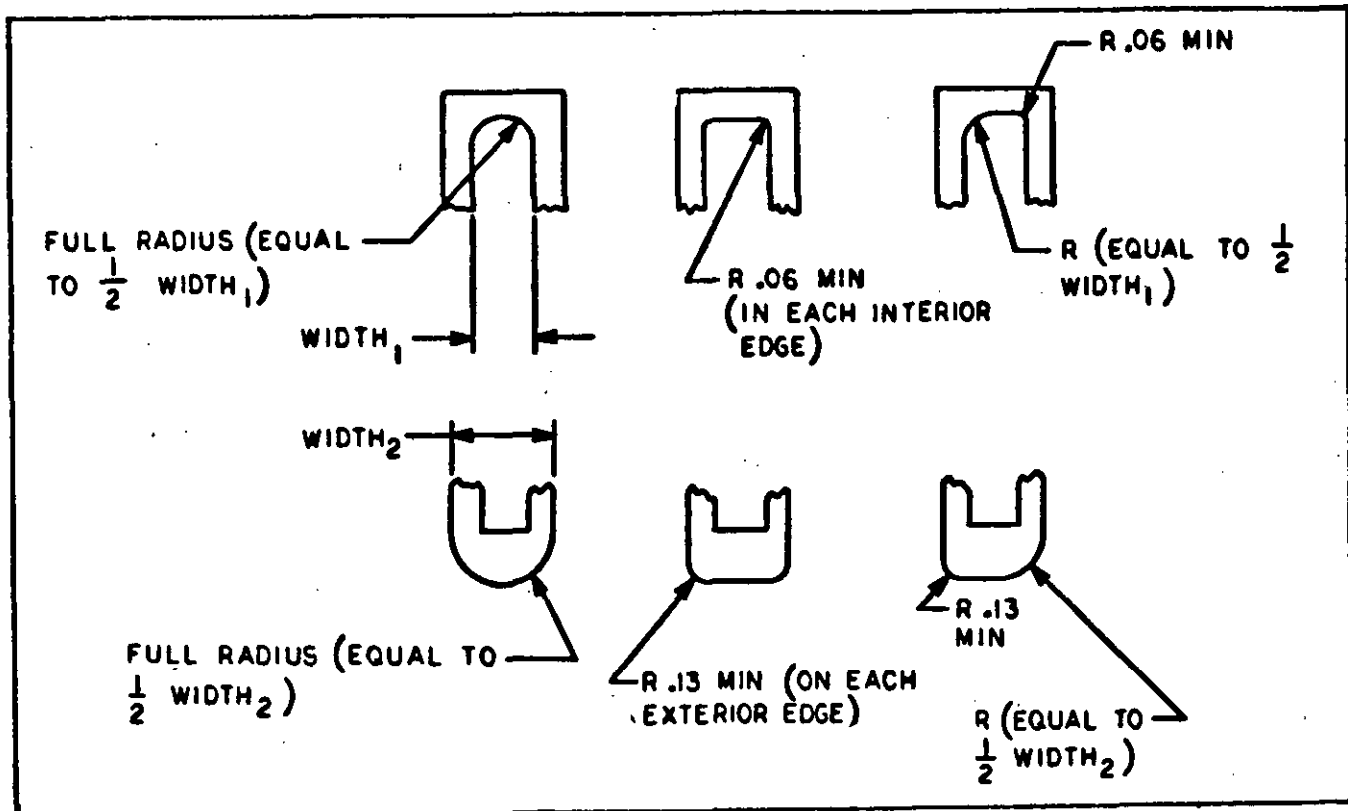

FIGURE 100-10. Permissible Variation in Part Configuration

DOD-STD-00100D(AR)

t. Small arms weapons barrel chambers. Barrel chambers shall be dimensioned in accordance with MIL-STD-1267.

u. Knurl dimensioning. Knurl dimensioning shall be in accordance with ANSI B94.6.

101.6 Surface texture. Surface texture, waviness and lay shall be indicated in accordance with ANSI B46.1.

101.6.1 Surface texture symbols. Surface texture symbols shall be in accordance with ANSI Y14.36.

101.7 Screw thread representation. Screw threads shall be represented in accordance with ANSI Y14.6 and Y14.6aM.

101.8 Gears. Gears shall be delineated in accordance with ANSI Y14.7.1 and Y14.7.2.

101.9 Mechanical springs. Mechanical springs shall be delineated in accordance with ANSI Y14.13.

101.10 Optical elements and optical systems. Optical elements and optical systems shall be delineated in accordance with MIL-STD-34.

101.11 Computer-aided preparation of product definition data. Terms and definitions used in computer-aided preparation of product definition data as applicable to engineering drawings shall be in accordance with ANSI Y14.26.3.

101.11.1 Computer-Aided Design (CAD) Drawings. The use of CAD in preparing drawings is acceptable provided:

a. The system is capable of generating full size drawings.

b. The full size drawings are prepared on material as specified in paragraph 104 and printing is on the front side of the format.

c. The full size drawings are capable of being revised in a conventional manner by any activity.

d. Microfilming requirements of MIL-M-9868 can be met.

101.11.2 Prior Government Design Activity approval is required for any deviation from para 101.11.1.

101.11.3 Line conventions may vary for CAD prepared drawings as follows:

a. All lines and letters on originals may be applied using ink.

b. All lines may be the same width provided microfilm requirements are met. It is preferred that lines for the outline of and features of the item be wider than dimension and extension lines.

c. Legibility is adequate to meet the requirements of MIL-D-5480.

DOD-STD-00100D(AR)

102 Graphic symbols, designations, letter symbols and abbreviations.

Graphic symbols, designations, letter symbols and abbreviations used on engineering drawings and associated lists shall be in accordance with the following standards. Where graphic symbols, designations, letter symbols and abbreviations are not covered by the listed standard; they may be used provided they are explained on each drawing or referenced to an explanatory document. The referenced explanatory documents shall be furnished with the engineering drawings. When non-standard graphic symbols, designations, letter symbols and abbreviations are used repeatedly, they should be forwarded to the custodian of this standard for possible inclusion in the respective standard. (See also paragraph 502.3.)

102.1 Graphic symbols.

102.1.1 Graphic symbols for electrical and electronics diagrams. Graphic symbols for electrical and electronics diagrams shall be in accordance with IEEE Std 315.

102.1.2 Graphic symbols for logic functions. Graphic symbols for logic functions shall be in accordance with IEEE Std 91.

102.1.3 Graphic symbols for flowchart diagrams. Flowchart symbols for use in information processing shall be in accordance with ANSI X3.5.

102.1.4 Graphic symbols for flueric power diagrams. Graphic symbols for flueric power diagrams shall be in accordance with MIL-STD-1306.

102.1.5 Graphic symbols for electrical wiring and layout diagrams used in architecture and building construction. Graphic symbols for electrical wiring and layout diagrams used in architecture and building construction shall be in accordance with ANSI Y32.9.

102.1.6 Mechanical symbols. Mechanical and piping symbols shall be in accordance with MIL-STD-17-1.

102.1.6.1 Graphic symbols for plumbing fixtures. Graphic symbols for plumbing fixtures for diagrams used in architecture and building construction shall be in accordance with ANSI Y32.4.

DOD-STD-00100D(AR)

102.1.7 Mechanical symbols for aeronautical, aerospacecraft, and spacecraft use. Graphic symbols for aeronautical aerospacecraft, and spacecraft diagrams shall be in accordance with MIL-STD-17-2.

102.1.7.1 Graphic symbols for aircraft hydraulic and pneumatic systems. Graphic symbols for aircraft hydraulic and pneumatic systems diagrams shall be in accordance with ANSI/SAE AS1290.

102.1.8 Ship structural symbols. Ship structural symbols shall be in accordance with MIL-STD-25.

102.1.9 Architectural symbols. Architectural symbols used on architectural drawings shall be in accordance with MIL-STD-14.

102.1.10 Electrical wiring equipment symbols for ships' drawings. Graphic symbols for electrical wiring equipment for ships' drawings shall be in accordance with MIL-STD-15-2.

102.1.11 Welding symbols. Welding symbols shall be in accordance with ANSI/AWS A2.4 together with terms and definitions in accordance with AWS A3.0.

102.1.12 Nondestructive testing symbols. Nondestructive testing symbols shall be in accordance with ANSI/AWS A2.4.

a. Nondestructive Examination. Nondestructive examination requirements shall be specified on the product drawing (See FIGURE 100-11) or on a separate drawing, using symbols in conformance with ANSI/AWS A2.4.

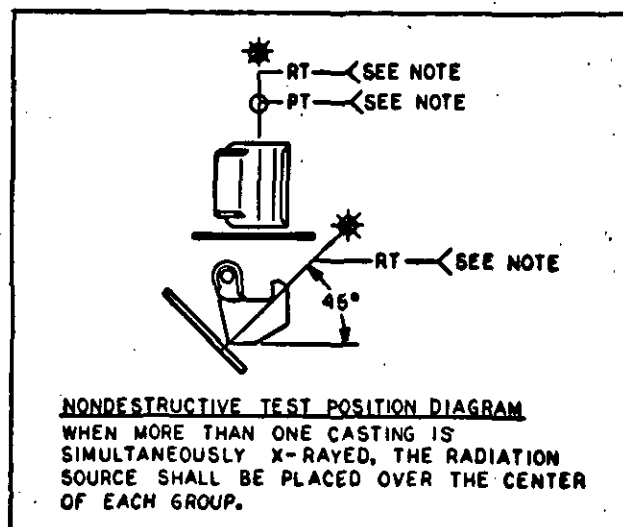

FIGURE 100-11. Example of Radiographic Position Diagram

DOD-STD-00100D(AR)

102.1.13 Graphic symbols for fluid power diagrams. Graphic symbols for fluid diagrams shall be in accordance with ANSI Y32.10.

102.2 Designations.

102.2.1 Reference designations for electrical and electronics parts and equipment. Reference designations shall be assigned in accordance with IEEE Stds 200 and 315.

102.3 Letter symbols and abbreviations.

102.3.1 Letter symbols. Letter symbols, when used on engineering drawings, shall be in accordance with ANSI Y10.3 and IEEE Stds 260 and 280.

102.3.2 Mathematical signs and symbols. Mathematical signs and symbols shall be in accordance with ANSI Y10.20 and Y10.20a.

102.3.3 Abbreviations. Abbreviations shall be in accordance with MIL-STD-12.

103 Diagrams.

103.1 Electrical and electronics diagrams. Electrical and electronics diagrams and interconnection diagrams shall be prepared in accordance with ANSI Y14.15, Y14.15a and Y14.15b.

103.2 Fluid power diagrams. Fluid power diagrams shall be prepared in accordance with ANSI Y14.17.

103.3 Printed wiring drawings. Printed wiring drawings shall be in accordance with, as applicable, the requirements of MIL-STD-275 and ANSI/IPC-T-50B.

103.3.1 Printed board description in digital form. When printed board descriptions are in digital form (defined either by metric or customary units) the description and form shall be in accordance with ANSI/IPC-D-350.

104 Drawing Material. Drawing material shall be plastic sheet in accordance with L-P-519, Type I, Class 2, .003 thick or Type 1, Class 1, .004 thick. Stable base plastic sheet shall be in accordance with MIL-STD-275 for printed circuit boards.

104.1 Duplicate Original. Brownline Sepia and ammonia developed reproductions are not acceptable as duplicate originals or stable base masters. The use of silver image duplicate originals on material as specified in paragraph 104 requires approval by the Government Design Activity, as specified in paragraph 101.2d.

105 Security classification and notation. See APPENDIX B.

DOD-STD-00100D(AR)

106 Scale. All drawings shall be drawn to scale except those described in paragraph 106.3.

106.1 Selection of scale. Drawings should show an object or assembly to full scale. When full scale is not practicable, drawings may be prepared to reduced or enlarged scale. It is desirable, whenever practicable, that detail drawings be prepared to the same scale as pertinent assembly drawings.

106.2 Indication of scale. The scale or scales to which drawings are prepared shall be indicated thereon by the fractional method in the drawing scale block. The scales to which the majority of views and sections are drawn shall be entered as a fraction (1/1, 1/4, 2/1, etc.) after "SCALE" in the space provided on the drawing format. The scale of each view or section drawn to other than the predominating scale shall be entered directly below the title of the view or section. e.g. SECTION A-A
SCALE 2/1

106.2.1 Fractional method. The fractional method expresses, in the form of a common fraction, the ratio of the size of the object as drawn to its full size.

Full size - 1/1

Enlarged - 10/1, 4/1, 2/1

Reduced - 1/2, 1/4, 1/8, 1/10, 1/20, 1/30, 1/40, 1/50, 1/60, 1/100

106.3 Drawings not to scale. In the case of diagrams, isometrics, perspective, tabulated and similar drawings not prepared to any scale, the word "NONE" shall be entered after "SCALE" in the space provided on the drawing format.

106.4 Dimensions not to scale. Where drawings were originally drawn to scale, but due to revision of the drawing some dimensions are not to scale, the not-to-scale dimension shall be underlined with a straight line. The configuration depicted shall be corrected at the first drawing redraw.

107 Radioactive materials. All drawings pertaining to items using radioactive materials shall be suitably marked with a caution note. See Appendix D for example.

108 Marking and marking location.

43
108.1 Identification marking requirements. The criteria for determining the physical application of identification numbers and what parts require identification shall be in accordance with MIL-STD-130.

DOD-STD-00100D(AR)

108.1.1 Drawing requirements. When an item requires identification markings, its drawing shall specify the exact marking requirements. Those requirements shall define the method and contents of the marking(s). For markings to be applied by rubber stamp, stencil, silk screening and similar processes, the material to be used in marking and any protective coatings shall also be specified. The Design Activity CAGE Code specified shall be that of the Design Activity that originally assigned the item's drawing number, even though it may be different than a design activity identified on the drawing as "CURRENT". The identifying number shall be the part number of the item as shown on its drawing. Example of requirements to be specified on drawings is as follows:

ITEM IDENTIFICATION: METAL STAMP, ENGRAVE OR ELECTRO ETCH THE FOLLOWING MARKINGS IN ACCORDANCE WITH MIL-STD-130 IN .13±.02 HIGH CHARACTERS.
"19200-12300007"
MFR--
MANUFACTURER'S CAGE CODE

ITEM IDENTIFICATION: METAL STAMP THE FOLLOWING MARKINGS IN ACCORDANCE WITH MIL-STD-130.
"19207ASSY12300008"
MFR--
MANUFACTURER'S CAGE CODE

ITEM IDENTIFICATION: RUBBER STAMP OR STENCIL THE FOLLOWING MARKINGS IN ACCORDANCE WITH MIL-STD-130 WITH WHITE INK TT-I-1795 IN .13±.02 HIGH CHARACTERS.
"19204-12340009"
MFR--
MANUFACTURER'S CAGE CODE
MARKINGS SHALL BE COATED WITH CLEAR LACQUER TT-L-50.

a. The manufacturer's CAGE Code (or FSCM or NSCM) will be the code of the prime contractor (not subcontractor) who is furnishing the part under contract with the government. For items defined by specification or source control drawings, the MFR CAGE Code to be applied will be that of the manufacturer of the item. In addition, Specification Control Items shall also be marked with the Government Design Activity CAGE Code and drawing number. Examples of requirements to be specified on drawings are as follows:

(1) For Source Control items:

ITEM IDENTIFICATION: RUBBER STAMP OR STENCIL THE FOLLOWING MARKINGS IN ACCORDANCE WITH MIL-STD-130 WITH WHITE INK TT-I-1795 IN .13±.02 HIGH CHARACTERS.
"19200SOCN14500001"
MFR--
MANUFACTURER'S CAGE CODE
MARKINGS SHALL BE COATED WITH CLEAR LACQUER TT-L-50.

(2) For Specification Control Items:

ITEM IDENTIFICATION: RUBBER STAMP OR STENCIL THE FOLLOWING MARKINGS IN ACCORDANCE WITH MIL-STD-130 WITH CONTRASTING COLOR INK TT-I-1795.
"19207-1550003"
MFR---
MANUFACTURER'S CAGE CODE PART NO.

DOD-STD-00100D(AR)

b. The location and size (if necessary) of the identification marking shall be specified on the depiction of the item if it must be controlled due to functional/fit requirements or subsequent finish application (paint, etc.). The location shall be identified by a leader pointing to the surface or, if necessary, by dimensionally locating the marking.

The location of identification marking on items that are subsequently camouflaged shall also be controlled and should be specified on surfaces that are not subjected to additional painting.

c. Items, which by their nature cannot be physically marked, shall be identified on their container in addition to or in combination with requirements of MIL-STD-129. An example of requirements to be specified on drawings is shown below:

(1) For other than Specification or Source Control items:

ITEM IDENTIFICATION: APPLY THE FOLLOWING
MARKING TO CONTAINER IN ACCORDANCE
WITH MIL-STD-130.
19200-12300002"
MFR-
CONTRACTOR'S CAGE CODE

(2) For Specification Control items:

ITEM IDENTIFICATION: APPLY THE FOLLOWING
MARKING TO CONTAINER IN ACCORDANCE
WITH MIL-STD-130.
19200-12300023"
MFR- -
MANUFACTURER'S CAGE CODE PART NO.

(3) For Source Control items:

45
ITEM IDENTIFICATION: APPLY THE FOLLOWING
MARKING TO CONTAINER IN ACCORDANCE
WITH MIL-STD-130.
19207SOCN7659325"
MFR-
MANUFACTURER'S CAGE CODE

DOD-STD-00100D(AR)

d. Requirements for identification marking of assemblies shall be specified on the assembly drawing. If assembly marking is physically applied to a part at the component level, the actual marking requirements shall be specified on the component drawing. The assembly drawing shall specify the marking requirement by reference to the component drawing.

e.g., On assembly drawing 1230008

In general notes

⑤ FOR IDENTIFICATION MARKING REQUIREMENTS SEE 1230077

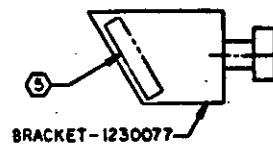

On component drawing 1230077

In general notes

② ITEM IDENTIFICATION: METAL STAMP THE FOLLOWING MARKING IN ACCORDANCE WITH MIL-STD-130.
 "19207ASSY1230008"
 MFR- MANUFACTURER'S CAGE CODE

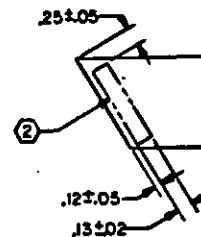

108.1.2 Matched parts. Matched parts require additional and specific part number markings. The part number of the item as assembled shall be applied to all parts of the matched set. The individual parts shall not have separate, individual part numbers applied.

a. Matched (parts) sets shall be serialized with a serial number composed of the last group of numerals of the applicable government contract under which the parts are manufactured followed by a consecutive serial number. For example, for contract DAAA09-85-C-0630, the first matched set serial number would be "SET 0630-1", and the second set would be "SET 0630-2", etc.

DOD-STD-00100D(AR)

b. Drawing requirements for matched parts shall include identification and serial number marking. An example of requirements to be specified on drawings is shown below.

ITEM IDENTIFICATION: METAL STAMP, ENGRAVE OR
ELECTRO ETCH THE FOLLOWING MARKINGS IN
ACCORDANCE WITH MIL-STD-130
19204-7796518
MFR- - - - MANUFACTURER'S CAGE CODE
SET- - - -

c. In addition, the drawing shall contain the following note:

MATCHED SET SERIAL NUMBER SHALL BE APPLIED
BELOW THE ITEM IDENTIFICATION AND BE COMPOSED
OF THE WORD "SET" FOLLOWED BY THE LAST FOUR
NUMERALS OF THE CONTRACT NUMBER, A DASH
AND A CONSECUTIVE SERIAL NUMBER.

108.1.3 Markings other than part number identification.

108.1.3.1 Rubber products. Rubber products shall also be marked with identification in accordance with MIL-STD-190. Drawings shall specify the type of marking, the marking material, the color(s) for environmental resistance and any exceptions to the MIL-STD-190 requirements.

108.1.3.2 CARC painted items. All items, i.e., tanks, trucks, howitzers, etc., coated with chemical agent resistant coating (CARC) shall have the word "CARC" and date applied near the data plate or nameplate of the item. The word "CARC" shall be in contrasting color, black or green, in block letters, .31 high minimum. The marking may be applied directly or by label or decal. The drawing shall specify the exact method of applying and location of the word "CARC".

108.1.3.3 Sensitive Electronic Device (SED) Items.

a. SED items shall be marked in accordance with MIL-STD-130.

b. Detail drawings of SED items and drawings of assemblies, equipment and equipment enclosures containing SED items, that are physically marked, shall specify the method, location and contents of the marking. For those applied by rubber stamp, stencil, silk screening and similar processes, the material to be used in marking and any protective coatings shall also be specified.

c. Marking symbols:

(1) For SED items, the symbol shall be in accordance with MIL-STD-1285, i.e.:



DOD-STD-00100D(AR)

(2) For assemblies, equipment and equipment enclosures, the symbol and accompanying note shall be as shown below.

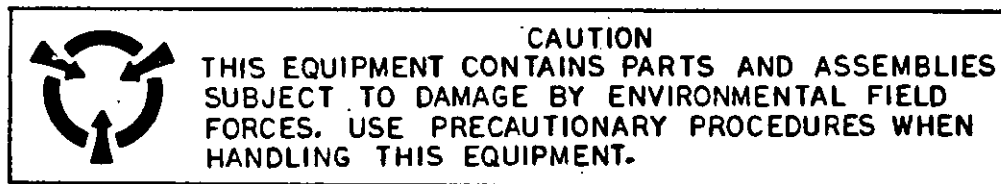

(3) The size of the marking shall be consistent with size of item to be marked.

(4) When the physical size of the item precludes the above marking, the marking will be applied on the unit package. In those cases, the following marking requirement shall be specified on the drawing in the general notes:

"SENSITIVE ELECTRONIC DEVICE CAUTION
 SYMBOL IS REQUIRED ON CONTAINER"

109 Optional/Alternative Designs. Optional/alternative designs of manufacturing a part, such as "casting" vs "weldment" may be specified. Where the differences between the designs would cause confusion in one set of views, an additional view or views shall be prepared with complete dimensional and other data specified thereon. The additional view or views shall be labeled "Optional Design" or "Alternative Design". Multiple sheet drawings shall be prepared when necessary.

110 Depiction of part. Drawings shall show the finished part (end item). Depiction of forgings, castings, blanks, etc., prior to-finishing operations shall not be delineated (either separately or on item drawing). As forged/cast/etc., surfaces remaining after finishing operations is permissible. Except for heat treatment and joining operations, e.g., soldering, brazing, riveting, etc., the drawing shall not specify the process to achieve or obtain the part.

DOD-STD-00100D(AR)

111 Module Data.

a. For a module, complete requirements covering all input and output parameters shall be specified. Typically, the data shall include, but not be limited to:

(1) A description of the module's function

(2) Input power

(3) Input and output signal characteristics in terms of voltage levels, wave shapes, pulse widths, rise and delay times, and settling time.

b. Where necessary to define a functional requirement, complete inspection test methods and procedures, including schematic diagrams of all inspection equipment setups shall be specified on the drawing or in a separate document referenced on the drawing.

c. In densely packaged modules, assemblies, units, wire harnesses and cables, the precise wire lay of leads carrying video, RF, IF, audio signals, logic pulses, as well as DC power, should, if necessary, be controlled by specific requirements on the drawings to preclude the adverse effects of coupling crosstalk, signal interference, etc. In those cases where special, particular or peculiar requirements can only be defined by step-by-step assembly procedures, such information shall be specified.

d. In addition, if inspection and alignment procedures are necessary to define functional requirements, the data required to functionally duplicate electrical inspection setups, including all alignment procedures used in adjustment and measurement of performance, shall also be specified. Complete step-by-step sequences shall be delineated, if necessary. Data shall include the electrical or mechanical characteristics for which the alignment is performed; e.g., wave shapes, oscillating frequencies, voltage and power levels, rise times, delay times, etc.

49
112 Analog signal processing circuits. Performance requirements for analog circuits shall include and completely define all input and output signal parameters.

113 Digital signal processing circuits. Performance requirements for digital circuits shall include all possible combinations of inputs and resulting outputs. Input and output signal parameters shall be explicitly defined. Truth tables alone will not be considered sufficient to specify the input and/or output characteristics of a given digital circuit. Truth tables may be provided as supplementary information. GO/NO-GO type acceptance criteria shall be acceptable only in those measurements where test effectiveness is not compromised. System clocks to which generated test signals are referenced shall meet the same frequency accuracy and short term stability requirements as the end item clock or of the system clock used to generate input signals to the end item. The following shall be specified when applicable:

DOD-STD-00100D(AR)

- a. Rise and fall times
- b. Amplitude and levels
- c. Phase relationships to other inputs
- d. Pulse width
- e. Overshoot and ringing
- f. Source impedance characteristics if non-linear
- g. Jitter
- h. Frequency and stability
- i. Bit patterns or "words"
- j. Interface circuitry required

114 Reference Identifiers. A reference identifier is issued to provide supplementary identification of an item that has been identified previously on the drawing or on a subordinate assembly. The use of reference identifiers shall be limited to instances that add substantially to drawing clarity. In order to differentiate from the item identification callouts, the following format shall be used:

a. Reference identifier shall be either the basic name or the basic name preceded by modifier(s) or part number as necessary (in instances where there are more than one part with the same basic name such as "PLATE" "SCREW" etc.).

b. Reference identifier shall be followed by the word "REF".

Examples:

"TRANSMISSION - REF"
 "FRONT BUMPER - REF"
 "123XXXX-2 - REF"

115 Application block entries. Cross references shall be entered in the drawing application block on sheet one (1) only as follows: The entry in the "NEXT ASSY" column shall be the drawing number(s) of the assemblies to which the detail or assembly pertains. The entry in the "USED ON" column shall be the nomenclature of the system/subsystem to which the item pertains. As a minimum, the nomenclature entered shall include the Model designator and basic noun or basic noun phrase.

116 Microcircuit. Drawings for microcircuits shall contain requirements as specified in MIL-M-38510, which include detail specifications, required tables, diagrams, schematics, interfacing connections and configuration.

DOD-STD-00100D(AR)

117 Drawing Notes.

117.1 Language style. The paramount consideration on a drawing is its technical essence, presented in language free of vague and ambiguous terms, using the simplest words and phrases that will convey the intended meaning. Inclusion of essential information shall be complete, whether by direct statements or reference to other documents. Consistency in terminology and organization of material will contribute to the drawing's clarity and usefulness. Sentences shall be short and concise. Punctuation must aid in reading and prevent misreading. Well-planned word order requires a minimum of punctuation. When extensive punctuation is necessary for clarity, the sentence(s) shall be rewritten. Sentences with compound clauses shall be converted into short and concise separate sentences.

117.2 Commonly used words and phrases. Certain words and phrases are frequently used on a drawing. The following rules shall be applied:

a. Reference documents shall be cited as follows:

- (1) "conforming to..."
- (2) "as specified in..."
- (3) "in accordance with..."

In any case, use the same wording throughout the drawing.

b. "Unless otherwise specified" shall be used to indicate an alternative course of action. The phrase shall always come at the beginning of the sentence, and, if possible, at the beginning of the note. This phrase shall be used only when it is possible to clarify its meaning by providing a reference such as another requirement or document.

117.3 Use of "shall", "will", "should" and "may".

a. "Shall". "Shall", the emphatic form of the verb, shall be used whenever a requirement is intended to express a provision that is binding.

b. "Will". "Will" may be used to express a declaration of purpose on the part of the Government. It may be necessary to use "will" in cases when simple futurity is required.

c. "Should" and "May". Use "should" and "may" whenever it is necessary to express non-mandatory provisions.

117.4 Indefinite terms. The terms "and/or", "etc.", "e.g.", and "i.e." shall not be used. On drawings, definite, precise language is imperative. Indefinite terms shall not be used.

117.5 Location of notes. The notes shall be placed in column form starting at the top left hand corner of the drawing or beneath the gear and/or spline data block.

DOD-STD-00100D(AR)

a. Multi-sheet drawings. For multi-sheet drawings, except for book form, all notes shall be on sheet 1 and continued on sheet 2, if necessary, and numbered consecutively starting with "1" on sheet 1 and continuing with next sequential number on sheet 2.

b. Book-form drawings. For book form drawings, the notes shall be located on sheet 2 and subsequent sheets if required.

c. Local notes. Local notes or notes on the face or field of the drawing should be avoided. Local notes should only be used to clarify requirements when a general note will not suffice.

117.6 Note contents. Drawing notes are pertinent data given in word form and used to complement the delineation of other given data. The arrangement of the notes shall not be interpreted as an order of precedence or sequence in manufacturing, assembly, etc., unless so specified on the drawing. The following shall be applicable in the preparation/use of notes.

a. Notes shall be numbered consecutively starting with NOTE 1 at the top of the column.

b. Subparagraphs shall be indented and identified by capital letters in alphabetical order.

c. Note form requirements shall supplement depiction on assembly drawings where necessary to define the required degree of looseness, tightness, rotation, or extent of travel without bind under spring action, orientation of parts or slots, etc.

d. Filling in voids (open spaces) to accommodate deletions and additions is not required and is not preferred.

e. When a note is deleted from a drawing, do not delete the number or renumber notes. Leave visible to indicate its previous use and potential future use.

f. Specifications and standards shall be listed without revision level or date, except for Dimensioning and Tolerancing Standard, ANSI Y14.5M-1982, ANSI Y14.5-1973, and DOD-STD-00100D(AR).

g. On tabulated drawings, different materials may be tabulated or specified by notes.

h. All specifications and standards to be used on drawings shall be reviewed for currency, adequacy, applicability, limitations and determination of need and also for class, grade, type, form, etc., and any other options required shall be specified.

DOD-STD-00100D(AR)

1. A 3/8 hexagon shall be placed around the note number when the note is referenced in the field of the drawing.

Example: (In general notes)

- ② IN ACCORDANCE WITH MIL-R-10509.
- 3. DIMENSIONAL LIMITS AND SURFACE TEXTURE APPLY WITHOUT PLATING.
- ④ IN ACCORDANCE WITH WW-C-440, TYPE I, GRADE B, SIZE 1/2.
- 5. FINISH 5.1.1 PLUS 24.1 OF MIL-STD-171, 303 GREEN, PRIMED BEFORE ASSEMBLY.
- 6. ITEM IDENTIFICATION: METAL STAMP, ENGRAVE OR ELECTRO ETCH THE FOLLOWING MARKINGS IN ACCORDANCE WITH MIL-STD-130 IN .13±02 HIGH CHARACTERS.
"19200-12300007"
MFR-  MANUFACTURER'S CAGE CODE

Examples: (In field of drawing)

6 - RESISTOR - RN60C2432F ②

3 - CLAMPS ④

j. Notes shall not duplicate information specified elsewhere on the drawing.

k. Where two or more statements are being considered for use in a single note, it is usually better to make each statement in a separate note.

l. Each drawing for which a QAP is prepared shall have the following note entered in the general note column. The QAP number specified shall be that associated with the item.

"QUALITY ASSURANCE PROVISIONS (QAP) 12345XX8
APPLY TO THIS ITEM."

m. Information conveyed by notes shall be accurate, complete and should have only one interpretation.

n. Drawings for all new items shall reference ANSI Y14.5M-1982 (Ref: See 101.5o.)

o. Other pertinent standards which are used and not specified in DOD-STD-00100D(AR) shall be listed in the notes.

DOD-STD-00100D(AR)

p. Any required processes (see paragraph 110) for an item shall be specified in the general notes. The note must be complete and define all of the pertinent variables. The hex symbol shall be used, if necessary, to reference specific locations or restriction of the process, as related to item configuration.

r. Protective finishes shall be in accordance with MIL-STD-171 and specified in the general notes.

Example:

"FINISH 5.1.1 PLUS 20.24.1 OF MIL-STD-171,
383 GREEN, PRIMED BEFORE ASSEMBLY."

s. Drawings shall contain protective finish requirements consistent with repair part provisioning, application of additional finishes either at subsequent assemblies (next or at system level) (e.g., finish painting or camouflage painting).

t. Threaded fasteners. Torque requirements for threaded fasteners shown on assembly drawings shall be specified as a general note when necessary.

u. General edge*/corner* break* requirements shall be specified as a general note. Requirements for specific feature(s) shall be shown where applicable in the field of the drawing. If applicable in more than one place, the requirement may be identified with the hexagon symbol method and specified in the general notes.

Examples: (In general notes)

"ALL EDGES AND CORNERS SHALL BE FREE FROM BURRS."

"ALL EDGES AND CORNERS SHALL BE BROKEN .005 + .010."

"ALL EXTERIOR CORNERS SHALL BE BROKEN R.02 + .02."

" .02 MAX EDGE BREAK."

"ALL INTERIOR CORNERS AND EDGES SHALL BE R.03 + .02."

Examples: (In field of drawing)

" 6 PLACES "

*6 X  

DOD-STD-00100D(AR)

v. Reference to special drawings or procedures shall be specified as in the following examples:

“FOR SCHEMATIC, SEE DRAWING 123XXXX5”

“FOR PERFORMANCE REQUIREMENTS, SEE MIL-P-12XXX”

w. Rights-to-Use Note on Government Drawings. When the source of a privately developed item agrees to furnish the privately owned data thereof in excess of and in addition to requirements under the contract and to permit use solely by or for the Government of all or any part of such data including such use in the preparation of military form drawings, all documents depicting such data when furnished will contain the following in the general notes:

“THE BLANK COMPANY, DETROIT, MICHIGAN, PART/DRAWING NUMBER AE 203, DATED 1 JANUARY 1980, CORRESPONDS TO THE DATA DEPICTED ON THIS DRAWING IN PART OR IN WHOLE. THESE DATA ARE FURNISHED FOR UNRESTRICTED USE IN CONNECTION WITH ANY GOVERNMENT MANUFACTURE OR PROCUREMENT AND NO OTHER USE IS AUTHORIZED BY AFORESAID COMPANY.”

The communication establishing the reference in the above note, as well as the data unrestricted for government use, is normally acquired during development of design and in the selection of components.

x. The applicable standards, performance requirements and mission item specifications, etc., shall be listed in note 1 as illustrated in the following examples: (Mission item specifications will be those identified by the Government Design Activity).

“— APPLICABLE STANDARDS/SPECIFICATIONS:
A. DOD-STD-00100D (AR)
B. ANSI Y14.5M-1982
C. MIL-W-13855”

“— APPLICABLE STANDARDS/SPECIFICATIONS:
A. DOD-STD-100
B. ANSI Y14.5-1973”

“— APPLICABLE STANDARDS/SPECIFICATIONS:
A. MIL-STD-8B”

y. Special notes for kits.

(1) Application note. An application note will always be included, noting the end items involved, for example:

A. Modification kit.

“THIS KIT IS DESIGNED FOR FIELD MODIFICATION (DAMWO) PURPOSES ONLY AND APPLIES TO ALL CARGO TRUCKS, M91X”

DOD-STD-00100D(AR)

- B. Accessory kit. "THIS KIT IS APPLICABLE TO ARMORED PERSONNEL CARRIER M22X."
- C. Conversion kit. "THIS KIT IS DESIGNED TO CONVERT A SEMITRAILER, VAN M51X TO A SHOP VAN M80X."

(2) Installation note. When kits are to be furnished in quantity and only a limited number of installation instruction drawings are required, the following installation note will be used: "THIS KIT IS TO BE INSTALLED IN ACCORDANCE WITH INSTRUCTION DWG XXXXXXXX WHICH WILL BE FURNISHED BY THE GOVERNMENT TO THE KIT MANUFACTURER AND/OR INSTALLERS IN SUCH QUANTITIES AS MAY BE DEEMED NECESSARY." When an installation instruction drawing is required with each kit, the installation instruction drawing will be listed as an integral part of the package contents drawing.

z. Cross-reference of special tools. Special tools shall be cross-referenced on the drawing of the part and assembly to which the tool applies. Cross reference shall be by use of a note as in the following example:

"FOR SPECIAL TOOL, SEE DRAWING XXXXXXXX (REF)"

This cross-reference is required to assure consideration of the tool in the event of a proposed change to the part.

118 Material Notes.

a. The material note shall specify an adopted non-government standard or government specification number and applicable composition(s), (material numbers). Unless otherwise indicated, the material specification shall apply to the finished item.

b. Materials shall be specified by indicating the basic name, specification, composition, and UNS designation (if listed in Unified Numbering System SAE HSJ 1086/ASTM DS 56) as a reference, e.g., "STEEL, ASTM A108: CF1211 (REF: UNS G12110)". The condition, temper, class, type, grade, etc., is not normally specified for material that requires subsequent heat treatment. Also the size of the material shall not be indicated as part of the material requirements unless it reflects the end (finished) item. The form shall be indicated only if critical to the finished product requirements.

Sample Notes.

"STEEL, ASTM A108: CF 1211 THRU 1213 (REF: UNS G12110 THRU G12130)"

"STEEL, MIL-S-16974: 4340 (REF: UNS G43400)"

DOD-STD-00100D(AR)

- c. Material requirements and selection shall be listed as a note.
- d. On tabulated detail drawings, the required material may be entered as a note or as one of the tabular requirements.
- e. Commercial materials shall not be specified on drawings. When Government or industry specifications/standards are not available, the commercial material shall be defined in specifications prepared in accordance with MIL-STD-490 or MIL-STD-961 and that specification shall be used for material requirements.
- f. When an item is a casting, it shall be classified in accordance with MIL-STD-2175 (See 102.1.12). A casting classification note, as in the following example, shall be specified on the drawing.
- "CASTING CLASSIFICATION, MIL-STD-2175; CLASS I,
GRADE B. RADIOGRAPHIC POSITION REQUIREMENTS SHALL
BE IN ACCORDANCE WITH DIAGRAM SHOWN."
- g. It is recommended that alternative materials also be specified if available.

119 Signing and dating drawings.

119.1 Signing drawings. Drawings shall be signed to verify technical content and adherence to applicable standards. See APPENDIX G for initial/signature requirements for manual and CAD generated drawings.

119.1.1 Signing for another. Drawings shall be signed only by designated persons unless responsibility is specifically delegated.

119.1.2 Redrawn drawings. Redrawn drawings with same number shall be treated as revised drawings. Signature/Initials entries in all applicable blocks shall be printed on the new drawing, except for signature/initials for revision block entries for that revision.

119.2 Dating drawings. The dating of engineering drawings serves to establish the original date* for historical record purposes. The original date will be retained for the life of the drawing. The method of specifying the original date shall be numerical by year-month-day (with a dash between entries) and shall be entered in the DATE block. For example 10 June 1986 would be "86-06-10". The original date shall be retained on redrawn drawings (same number). On multi-sheet drawings, all sheets (except A size continuation sheet) shall have the same original date as on sheet 1. (See paragraph 402.17.)

DOD-STD-00100D(AR)

119.3 Initial and Signature Block. The drawing format contains a block for entries to be made by the draftsman, checker, engineers and individuals responsible for approval of the data. Entries for these blocks shall be as follows:

- a. DRAWN BY - The initials of the person who prepared the original drawing.
- b. CHECKER - The initials of the person who checked the original drawing for completeness, accuracy, and preciseness.
- c. ENGINEER - The signature of the engineer responsible for the design of the item depicted.
- d. DRAWING APPROVAL - The signature of the authorized Government Design Activity representative responsible for drawing format and completeness. Date entry is optional.
- e. DESIGN APPROVAL - The signature of the authorized Government Design Activity representative responsible for design technical adequacy and conformance to end item requirements. Date entry is optional.
- f. MATL ENGR - The initials of the authorized Government Design Activity or authorized contractor representative(s) (or both) responsible for the adequacy of materials, heat treatment, mechanical properties, and protective finish.

119.4 Additional signatures. Additional signatures as required by the preparing activity may be entered in blocks added in the optional use block. See APPENDIX A.

119.5 CAD prepared drawings. CAD prepared drawings shall be initially signed as defined above. After approval, subsequent generations may show printed initials and names of those who initially signed the first generation drawing.

119.6 For microfilms generated directly from the computer without an original drawing (prior Government Design Activity approval is required), the original date and signatures shall be applied to the back of a master silver microfilm aperture card in blocks duplicating those of the drawing format. See FIGURE 100-12. Subsequent generations may also show printed initials and names of those who initially signed the first generation drawing.

DOD-STD-00100D(AR)

		DRAWING NO.	
DRAWN BY		ENGINEER	
CHECKER		DESIGN APPROVAL	
DRAWING APPROVAL			
DESIGN APPROVAL			
MATL ENGR			
LTR	REVISION APPROVED	DATE (YR-MO-DA)	

FIGURE 100-12. Sample Microfilm Aperture Card Signature/Revision Blocks

This sample drawing is informational only and complete to the degree necessary to illustrate a type of drawing. Actual format and drawing shall conform to the textual requirements set forth in this standard.

DOD-STD00100D(AR)

THIS PAGE LEFT BLANK INTENTIONALLY

60

DOD-STD-00100D(AR)

CHAPTER 200 TYPES OF ENGINEERING DRAWINGS

200 General. This chapter defines and illustrates the types of engineering drawings normally prepared by and for the Departments and Agencies of the Department of Defense.

201 Definitions and requirements. Definitions for words and terms marked with an asterisk (*) are located in Chapter 700.

201.1 Engineering drawing. An engineering drawing is an engineering document that discloses (directly or by reference) by means of pictorial or textual presentations, or combinations of both, the physical and functional end-product* requirements of an item.

201.1.1 Application. Normally, several types of engineering drawings combined into sets with attendant associated lists are required to completely define the end-product* requirements of an item. As a minimum, a combination of detail and assembly drawings may suffice to define these requirements. However, as the complexity of the item increases, specialized engineering drawings may be required to provide for full engineering description. As a rule, combinations of detail, assembly, control, installation and diagrammatic drawings will provide the necessary engineering description. In certain cases, special purpose drawings (paragraph 201.9) may be required for management control, logistic purposes, configuration management, manufacturing aids, and other unique functions as might be required by a Government Design Activity.

201.1.2 Integral parts list. When a parts list is prepared integral with the drawing, its location and size shall be as specified in APPENDIX A-3. (See 401.6.) Additional parts lists blocks may be located to the left of, and adjacent to, the original block or on a continuation sheet of the same drawing. The integral parts list shall not be utilized without prior approval of the responsible Government Design Activity.

201.2 Detail drawing. A detail drawing depicts complete item requirements for the part(s) delineated on the drawing except when additional end-product* requirements are accomplished on inseparable assembly drawings, e.g., mating holes.

201.2.1 Monodetail drawing. A monodetail drawing delineates a single part. See FIGURE 200-1. Except as otherwise specified by the Government Design Activity, a monodetail or tabulated drawing shall be prepared for each identifiable part for which there is no existing data.

201.2.1.1 Requirements. A monodetail drawing shall define all features of the item depicted, including, as applicable, configuration, dimensions, tolerances, materials, mandatory processes, surface finish, protective coating, symbols, etc. Documents required to supplement the detail drawing in stating end-product* requirements for the item shall be prescribed by notes or tables on the drawing.

DOD-STD-00100D (AR)

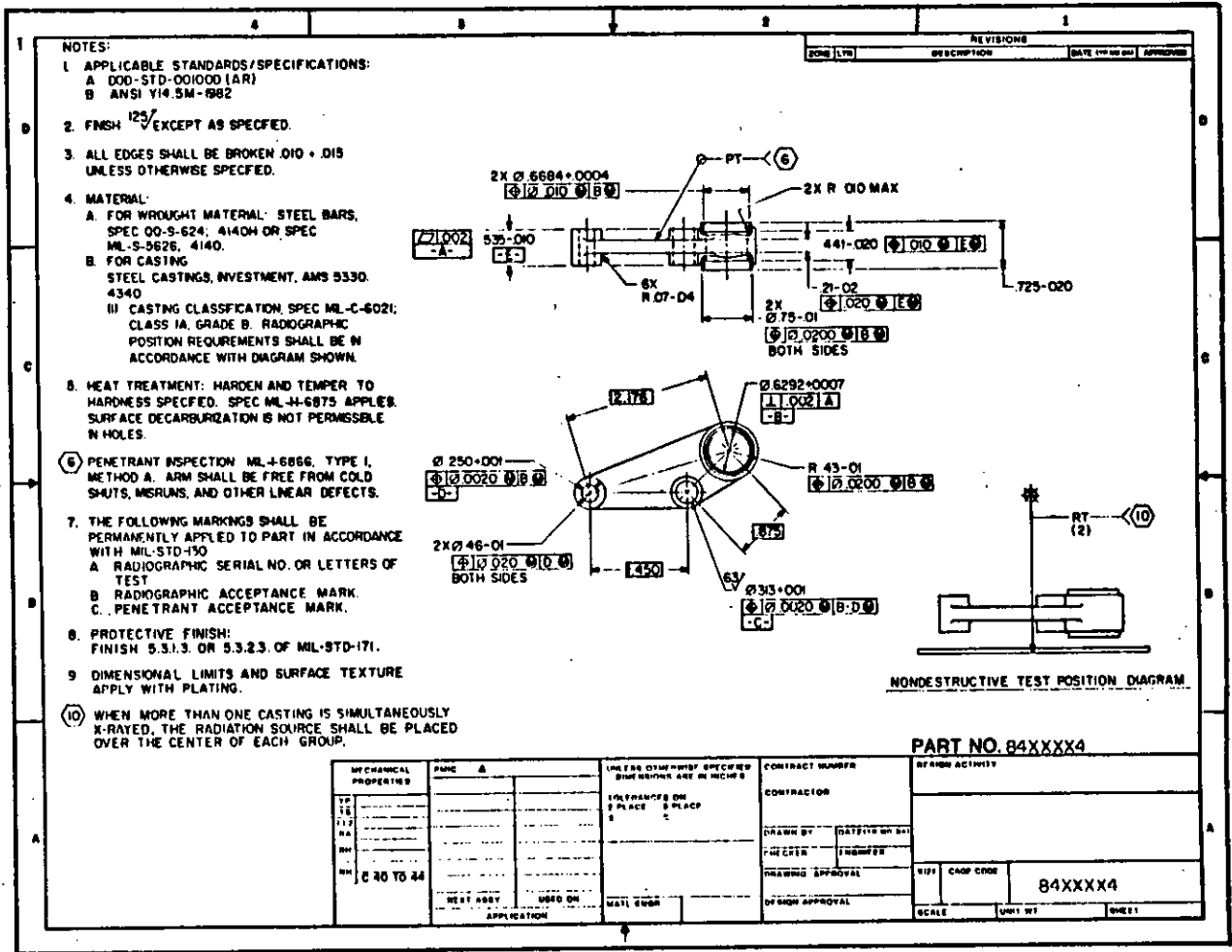

FIGURE 200-1. Monodetail drawing

201.2.2 Multi-detail drawing. Multi-detail drawings may be used to delineate packaging, packing, palletizing, carloading arrangements and special tooling used as manufacturing aids for installation of modification kits. See FIGURE 200-2.

201.2.2.1 Requirements. Each part depicted on a multi-detail drawing shall meet the requirements of paragraph 201.2.1.1.

This sample drawing is informational only and complete to the degree necessary to illustrate a type of drawing. Actual format and drawing shall conform to the textual requirements set forth in this standard.

DOD-STD-00100D(AR)

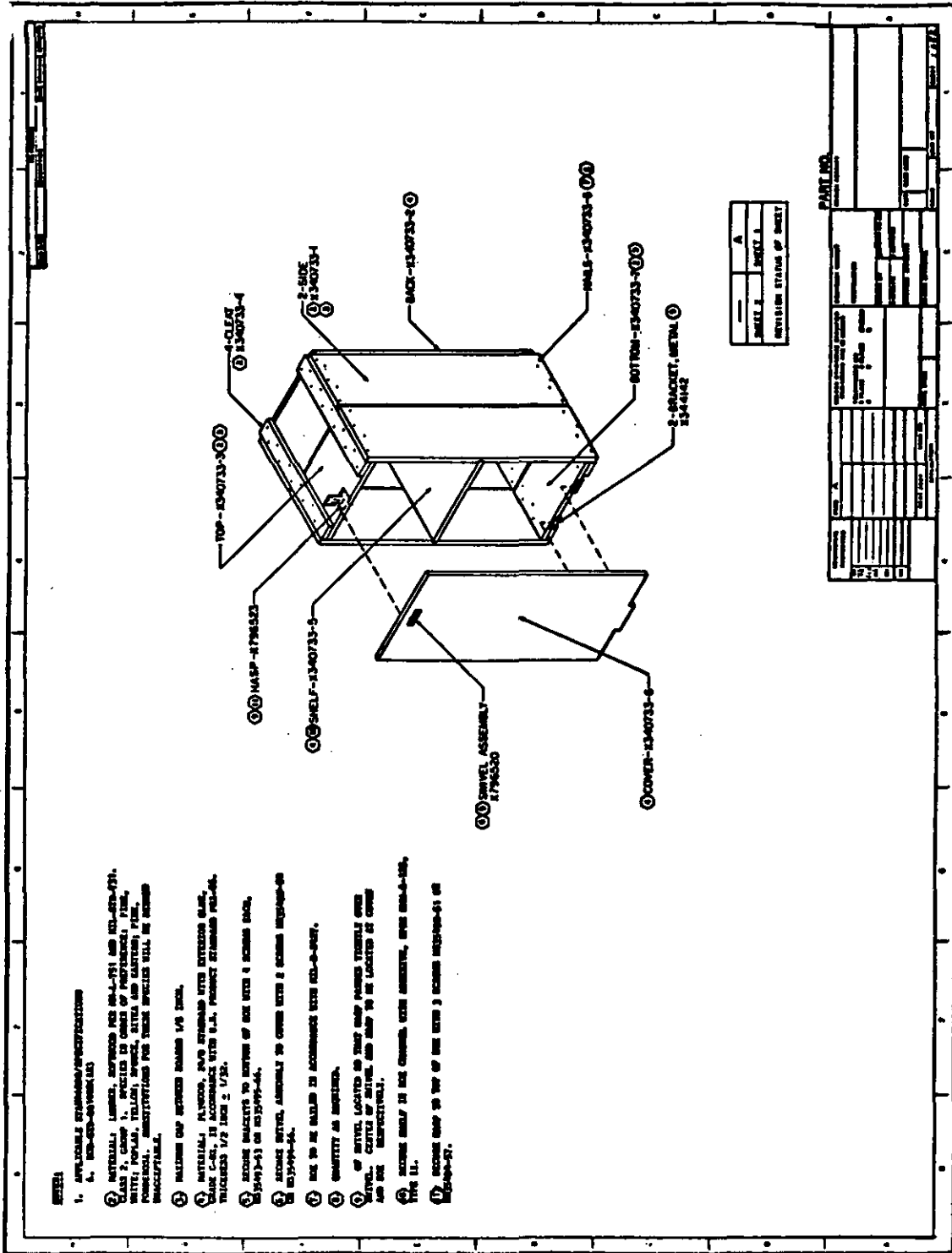

FIGURE 200-2. Multi-detail drawing

This sample drawing is informational only and complete to the degree necessary to illustrate a type of drawing. Actual format and drawing shall conform to the textual requirements set forth in this standard.

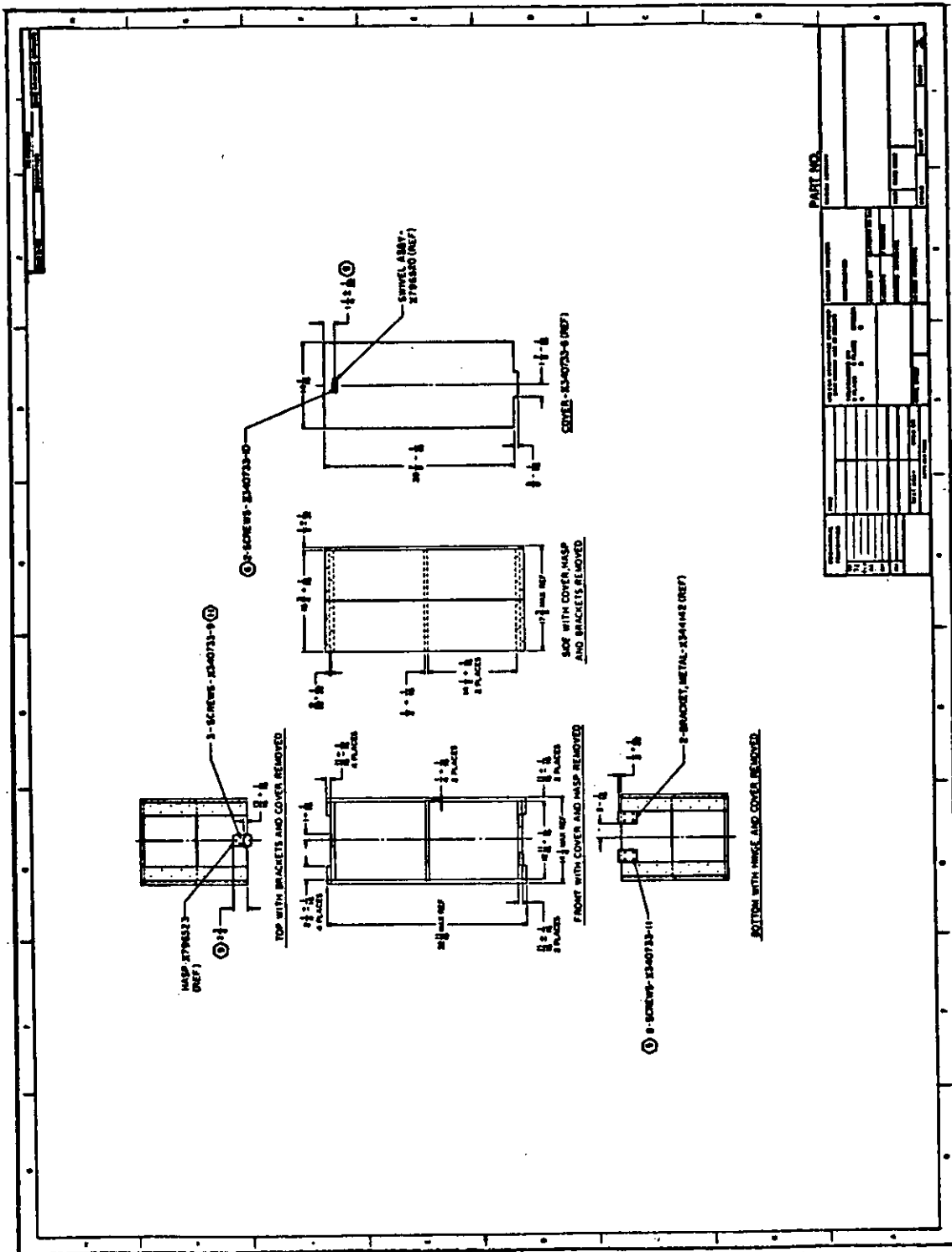

FIGURE 200-2. Multi-detail drawing (Cont'd)

This sample drawing is informational only and complete to the degree necessary to illustrate a type of drawing. Actual format and drawing shall conform to the textual requirements set forth in this standard.

DOD-STD-00100D(AR)

201.2.3 Tabulated detail drawing. A tabulated detail drawing depicts similar items, which as a group, have constant and variable characteristics. Each item is uniquely identified. See paragraphs 402.5 and 402.6. A tabulated detail drawing precludes the preparation of an individual drawing for each item tabulated. Tabulated drawings shall be utilized to the maximum extent. Each item will have part number assignment using the drawing number and adding -1, -2, etc., for each item. See FIGURE 200-3.

201.2.3.1 Requirements. The difference (variables) between the items defined by a tabulated drawing shall be tabulated, and the fixed (constant) characteristics shall be depicted or stated once. Normally, a pictorial representation of a single item is shown, with variable dimensions coded by means of letters used as headings for columns in the tabulation. The variables are entered in the table under the appropriate headings and on the same line as the identifying number or letter of the item to which they pertain. The statement of requirements shall be as complete as that required by paragraph 201.2.1.1 for a single part.

NOTES:		REVISIONS																							
		ZONE (LTH)	DESCRIPTION	DATE (YR-MO-DAY)	APPROVED																				
1. APPLICABLE STANDARDS/SPECIFICATIONS: A. DOD-STD-00100D(AR) B. ANSI Y14.5M-1982 2. MATERIAL: CORROSION RESISTING STEEL, CLASS 301 OR 302, TEMPER 1/4 TO FULL HARD, SPEC QQ-3-768. 3. PROTECTIVE FINISH: FINISH 5.4.1 OF MIL-STD-171.																									
		<table border="1"> <thead> <tr> <th>PART NO.</th> <th>Ø A -0.05</th> <th>Ø B +0.05</th> <th>DIM C</th> </tr> </thead> <tbody> <tr> <td>844XX15-1</td> <td></td> <td></td> <td>00201.0002</td> </tr> <tr> <td>844XX15-2</td> <td>550</td> <td>.380</td> <td>00501.0005</td> </tr> <tr> <td>844XX15-3</td> <td></td> <td></td> <td>00201.0002</td> </tr> <tr> <td>844XX15-4</td> <td>.690</td> <td>.592</td> <td>00501.0005</td> </tr> </tbody> </table>				PART NO.	Ø A -0.05	Ø B +0.05	DIM C	844XX15-1			00201.0002	844XX15-2	550	.380	00501.0005	844XX15-3			00201.0002	844XX15-4	.690	.592	00501.0005
PART NO.	Ø A -0.05	Ø B +0.05	DIM C																						
844XX15-1			00201.0002																						
844XX15-2	550	.380	00501.0005																						
844XX15-3			00201.0002																						
844XX15-4	.690	.592	00501.0005																						
		PART NO. (SEE TABLE)																							
MECHANICAL PROPERTIES		FINIS A		UNLESS OTHERWISE SPECIFIED DIMENSIONS ARE IN INCHES																					
TP TR FL RA BR		MFG APLN		CONTRACT NUMBER CONTRACTOR DRAWN BY DATE (YR-MO-DAY) CHECKED BY DATE (YR-MO-DAY) DRAWING APPROVAL DESIGN APPROVAL																					
10 PLACES ON 5 PLACE 2 PLACE 1 PLACE		MFG ENGR APLN ENGR		SCALE UNIT WT SHEET																					

FIGURE 200-3. Tabulated detail drawing

This sample drawing is informational only and complete to the degree necessary to illustrate a type of drawing. Actual format and drawing shall conform to the textual requirements set forth in this standard.

DOD-STD-00100D(AR)

201.2.4 Tube bend drawing. A tube bend drawing depicts, by means of pictorial or tabular delineation, or combinations thereof, complete bend data required to describe the configuration of a rigid metal tube. Two basic methods of delineating the tube bend data are illustrated. See FIGURES 200-4 and 200-5.

201.2.4.1 Requirements. A tube bend drawing shall disclose, as applicable, tube material, type ends, identification and quantity of fittings, bend radii and angles, intersection points, intermediate and overall lengths and all other data required to define the item. Tubing of complex configuration shall be disclosed by utilizing combinations of pictorial and tabular delineation; while tubing having simple configuration may be defined by means of tabular presentation.

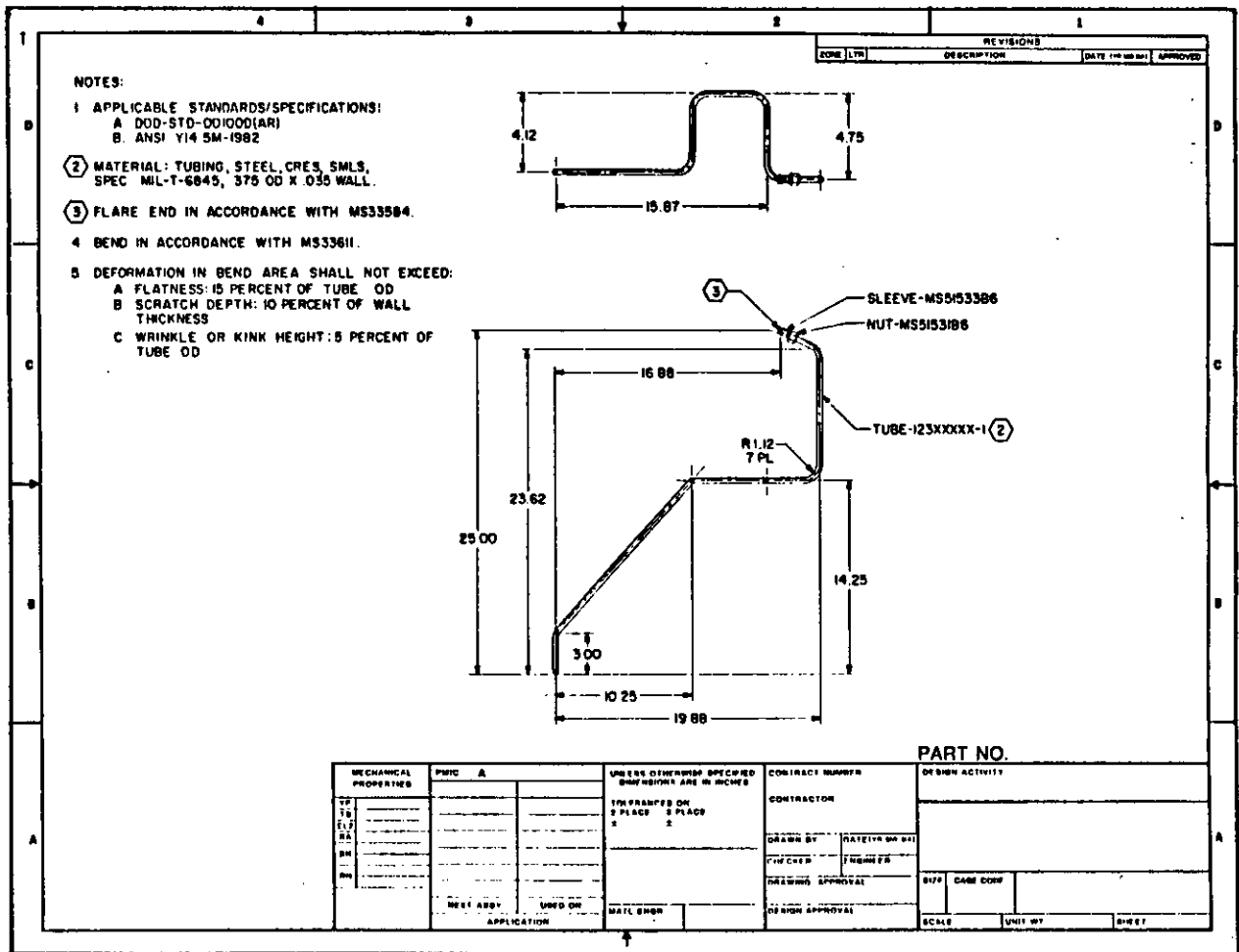

FIGURE 200-4. Tube bend drawing

This sample drawing is informational only and complete to the degree necessary to illustrate a type of drawing. Actual format and drawing shall conform to the textual requirements set forth in this standard.

DOD-STD-00100D(AR)

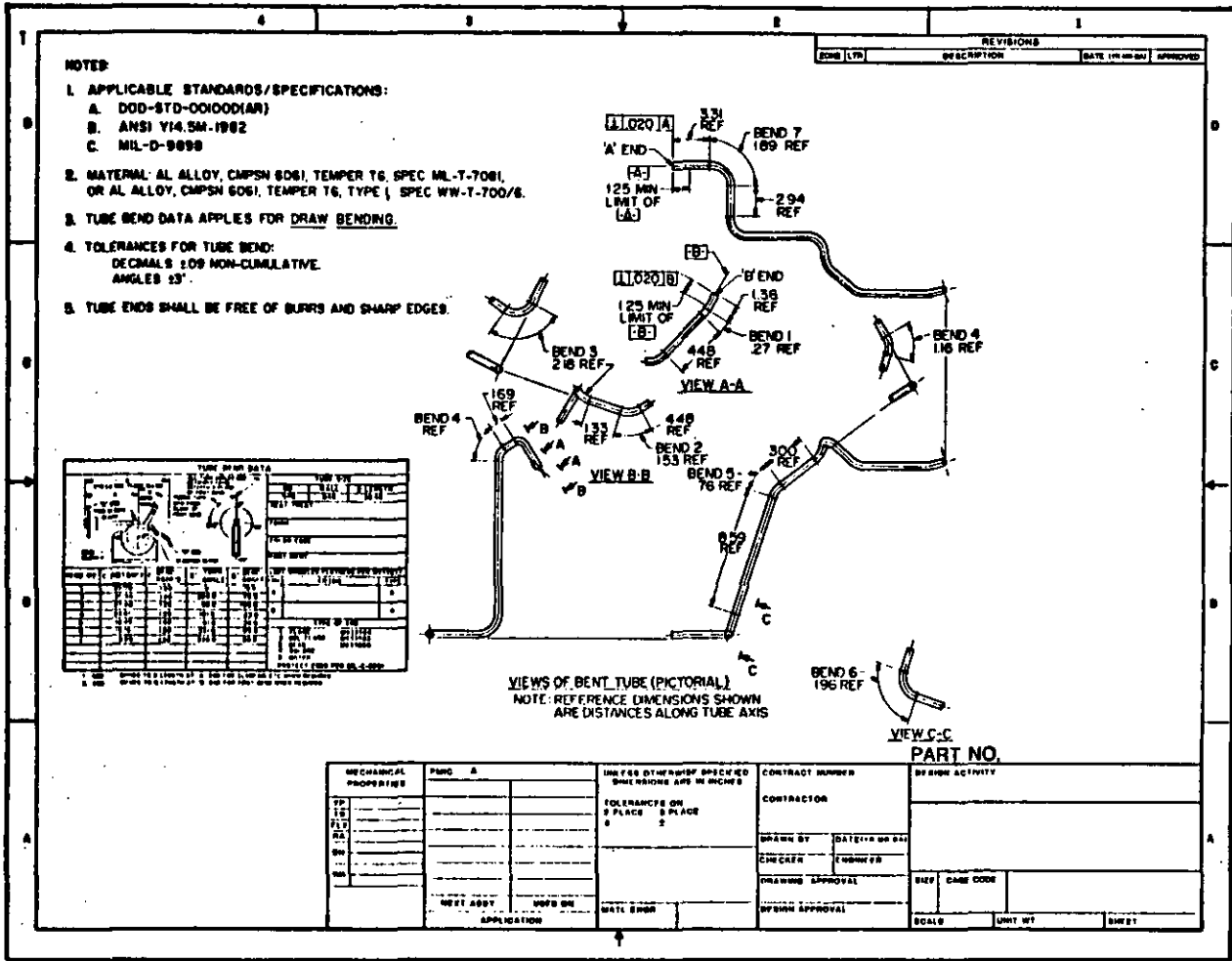

FIGURE 200-5. Tube bend drawing

This sample drawing is informational only and complete to the degree necessary to illustrate a type of drawing. Actual format and drawing shall conform to the textual requirements set forth in this standard.

DOD-STD-00100D(AR)

201.3 Assembly drawing. An assembly drawing depicts the assembled relationship of (a) two or more parts, (b) a combination of parts and subordinate assemblies, or (c) a group of assemblies required to form an assembly of higher order. It shall contain sufficient views to show the relationship between each subordinate assembly and parts in the assembly depicted. Subordinate assemblies and parts shall be called out in the field of the drawing, either by their identifying (part) numbers or by find (item) numbers cross-referenced to the identifying numbers in a table on the drawing. The nomenclature shall be entered as it appears on its own drawing, but may be abbreviated by using the basic noun or noun phrase. When information regarding the assembled relationship and identification of parts is shown on assembly drawings of subordinate assemblies, it should not be repeated on the assembly drawings of higher order. Only the identifying number of each subordinate assembly, its configuration and location shall be shown. Assembly drawings shall contain references to pertinent associated lists, installation drawings, wiring and schematic diagrams, etc. The division of an item into subordinate assemblies shall be, when possible, in accordance with practical assembly and disassembly procedures. Assembly drawings shall be prepared for the system/subsystem and for each level of subassembly required for repair parts supply, bench subassembly and testing, localization of major functional requirements and adjustments, and clarity of parts identification, assembly and diagnostic procedures. If applicable, each subassembly drawing shall include pertinent functional requirements. See FIGURE 200-6.

NOTE 1: Electrical items shall be shown and identified on assembly drawings depicting where mounted; however, small electrical items mounted by means of wires affixed hereto may be shown and identified either on the assembly drawing or on the pertinent wiring diagram.

NOTE 2: Attaching parts (bolts, nuts, washers, etc.) required to mount and retain assemblies on foundations or on assemblies of higher order shall be called out on the drawing showing the item on which the attachment takes place.

DOD-STD-00100D(AR)

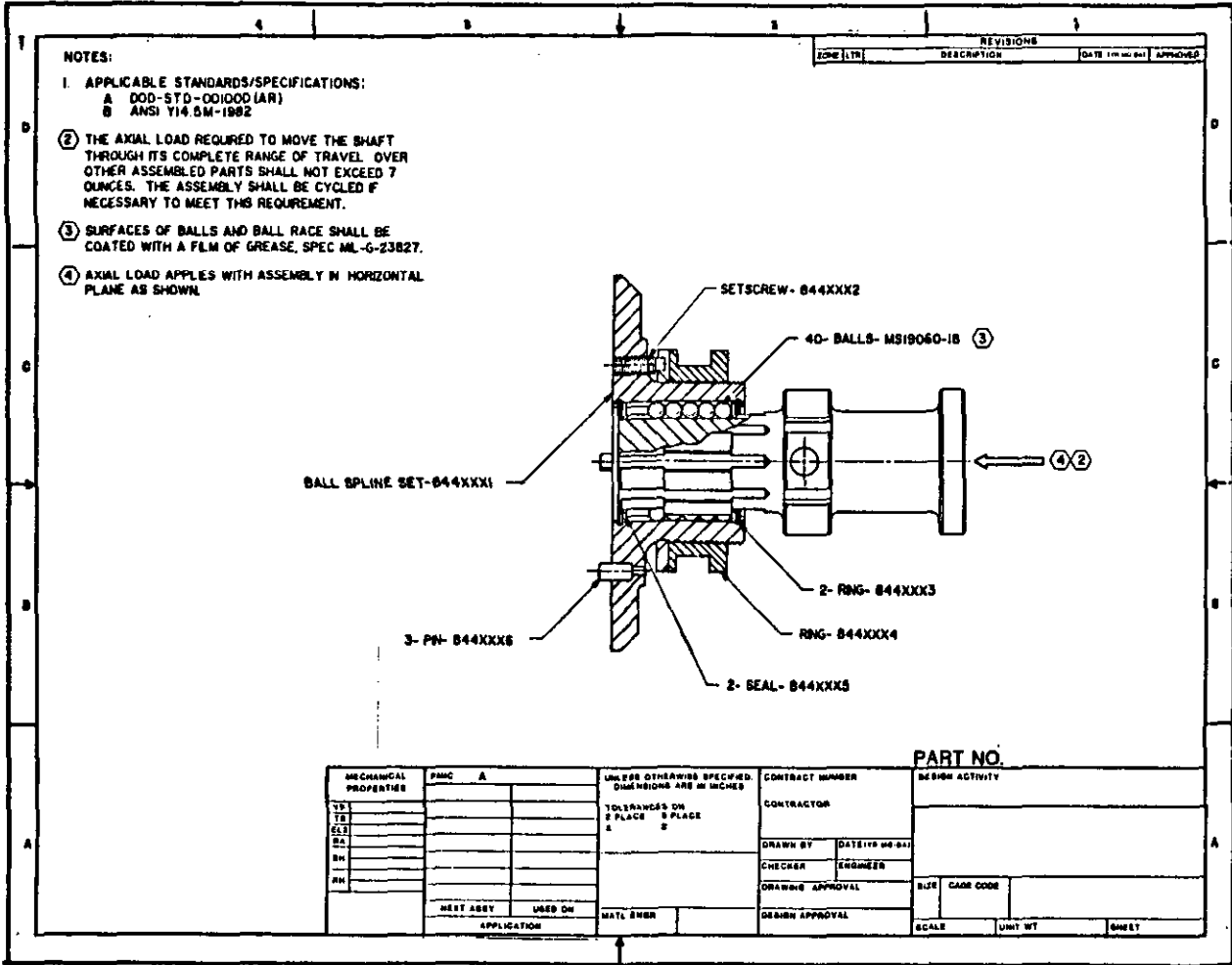

FIGURE 200-6. Assembly drawing

This sample drawing is informational only and complete to the degree necessary to illustrate a type of drawing. Actual format and drawing shall conform to the textual requirements set forth in this standard.

69

201.3.1 Detail assembly drawing. A detail assembly drawing depicts an assembly on which one or more parts are detailed in the assembly view or on detail views. Except as provided below, separate engineering drawings are not required for parts so delineated.

a. Detail Assembly drawings covering inseparable assemblies may be prepared in lieu of individual Monodetail drawings provided that none of the parts detailed thereon are stocked for repair of the item and that clarity is not adversely affected. Example: a welded, riveted, or sewn assembly (box, bracket, canvas case) intended to be procured and replaced as a unit, however, may be subject to repair by replacement of individual parts. Military Standard parts shall be specified on Detail Assembly drawings, as applicable. A glass prism bonded to an aluminum plate would require support by monodetail drawings. Monodetail drawings shall be used whenever they are necessary for clarity of complex configurations.

b. Detail assembly drawings may also be used for matched parts and special tooling used as manufacturing aids for installation of modification kits. See FIGURE 200-7.

201.3.1.1 Requirements. Details of parts and assembly views in detail assembly drawings shall have the completeness required by paragraphs 201.2.1.1 and 201.3.

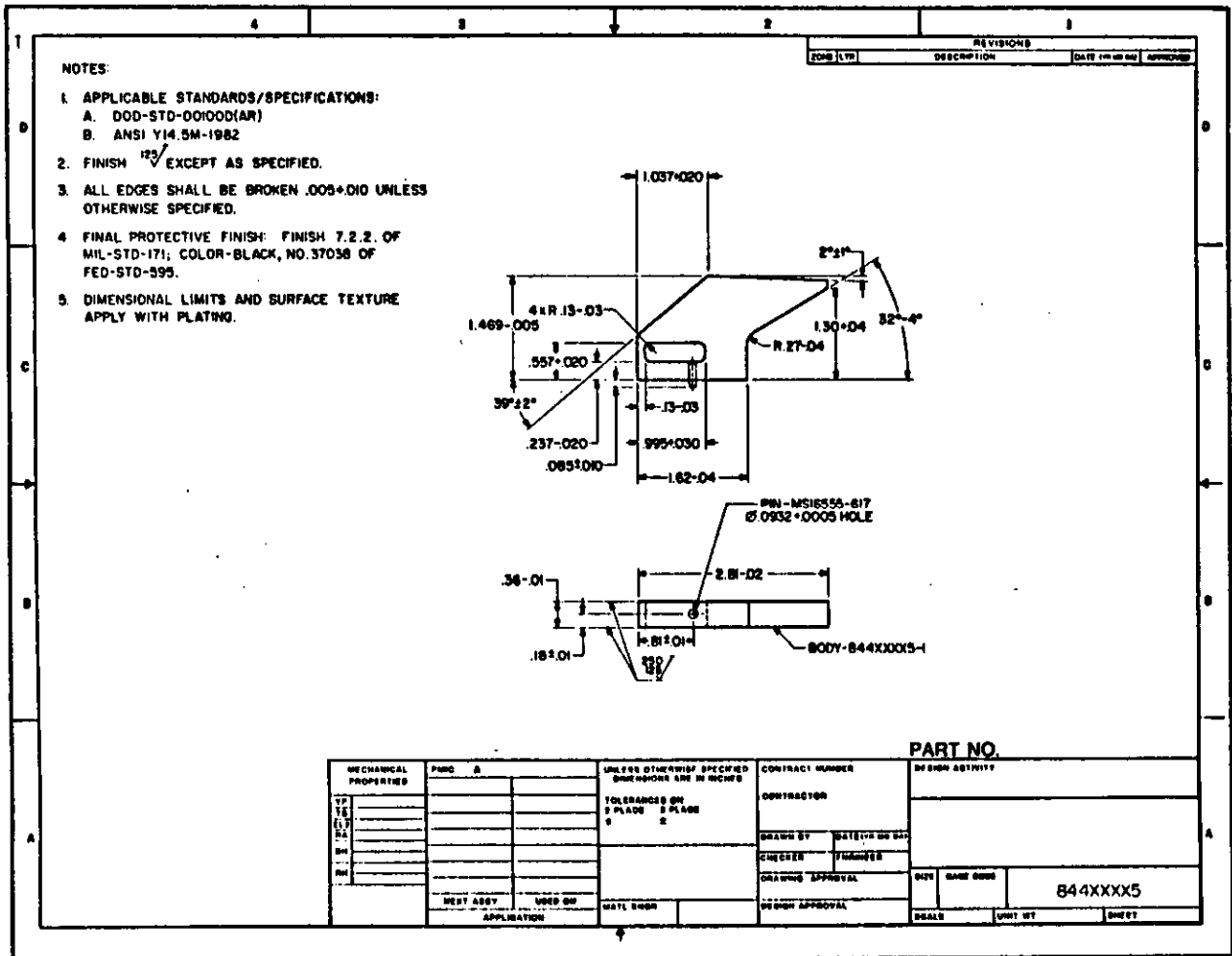

FIGURE 200-7. Detail assembly drawing

This sample drawing is informational only and complete to the degree necessary to illustrate a type of drawing. Actual format and drawing shall conform to the textual requirements set forth in this standard.

DOD-STD-00100D(AR)

201.3.2 Tabulated assembly drawing. An assembly drawing depicting more than one assembly by tabulation such as the requirement for a tabulated detail drawing (see paragraph 201.2.3) shall clearly delineate the difference between each tabulated assembly, and uniquely identify each. See paragraphs 402.5 and 402.6. See FIGURE 200-8.

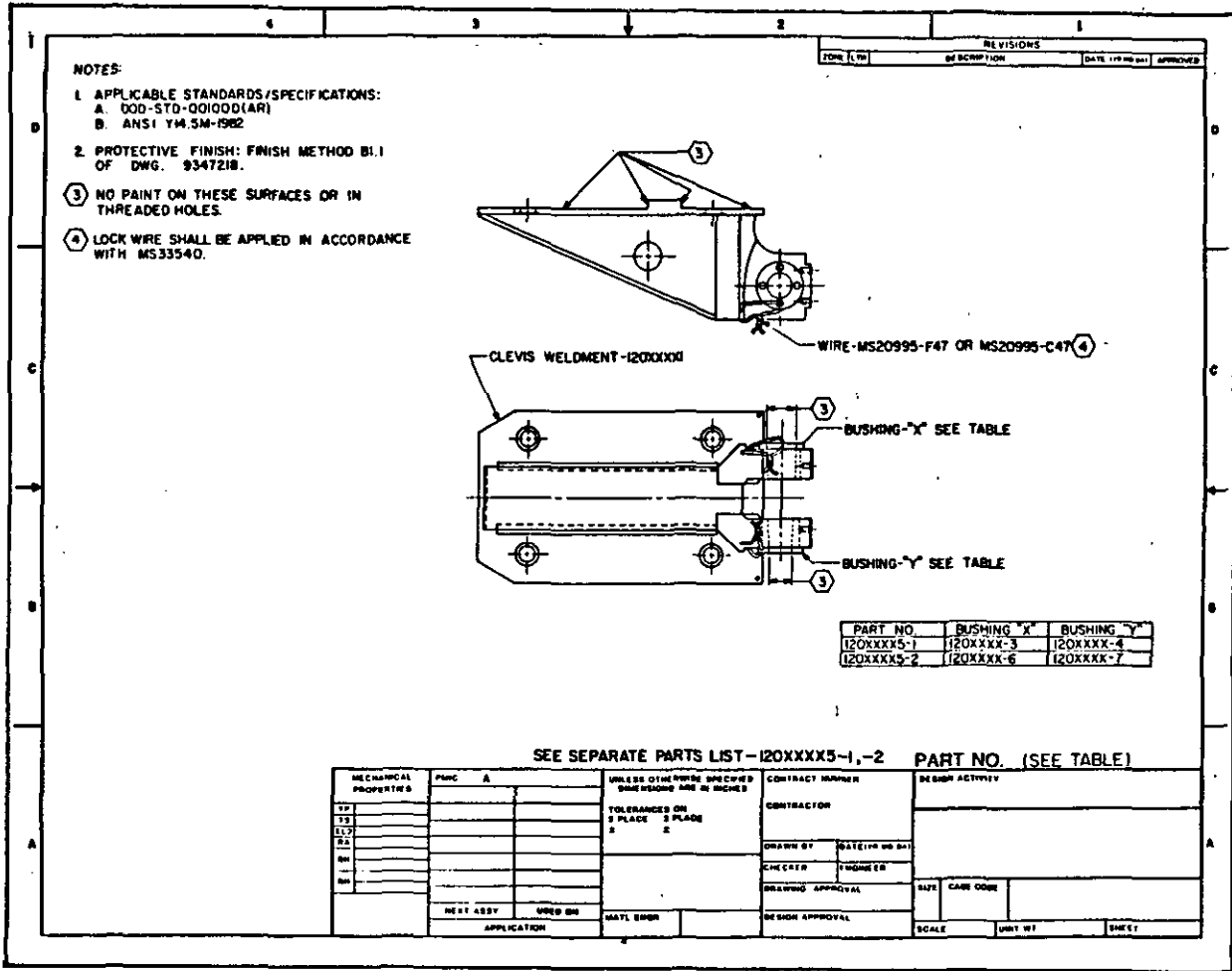

FIGURE 200-8. Tabulated assembly drawing

This sample drawing is informational only and complete to the degree necessary to illustrate a type of drawing. Actual format and drawing shall conform to the textual requirements set forth in this standard.

DOD-STD-00100D(AR)

201.3.3 Photo-assembly drawing. When applicable, photo-assembly drawings may be prepared using halftone (screened) photographs of an item(s) in a format and incorporating the additional information required to complete the drawing. Photo-assembly drawings shall be of such clarity that subsequent full or reduced size copies are sufficiently legible, and the configuration must be clear and easily understood.

NOTE 1: When microfilm is required, delivery of full size drawings, as in the case of undimensioned drawings of photo-masters used for printed circuit requirements, may be required when specified in the contract or order.

NOTE 2: The word "assembly" as used in the name of the type of drawing for this requirement, means an assemblage of halftone photograph(s) and line work to complete the drawing requirements. It is not intended to mean an assembly of parts, although it is frequently used for that purpose.

NOTE 3: Reprographic drawings or tracings are those drawings reproduced (duplicated) by a photographic technique and are not to be construed as meeting the requirements for a photo-assembly drawing. See paragraph 101.2c.

201.3.4 Inseparable assembly drawing. An inseparable assembly drawing delineates items (pieces) which are separately fabricated and are permanently joined together (e.g., welded, brazed, riveted, sewed, glued, etc.) to form an integral unit (part) not capable of being disassembled for replacement or repair of the individual pieces. An inseparable assembly drawing may be prepared in lieu of individual monodetail drawings for inseparable (welded, brazed, bonded, riveted, sewn, or glued) assemblies intended to be procured and replaced as a unit, where (except for standard hardware) the separate parts are of similar materials. Example: A welded or riveted bracket, a wood, metal, or plastic chest, or a canvas case may be covered by an inseparable assembly drawing without monodetail drawings. See FIGURE 200-9.

201.3.4.1 Requirements. An inseparable assembly drawing shall fully define the end-product* as assembled. Pieces of the inseparable assembly may be detailed either on separate detail drawings or on the inseparable assembly drawing itself.

DOD-STD-00100D(AR)

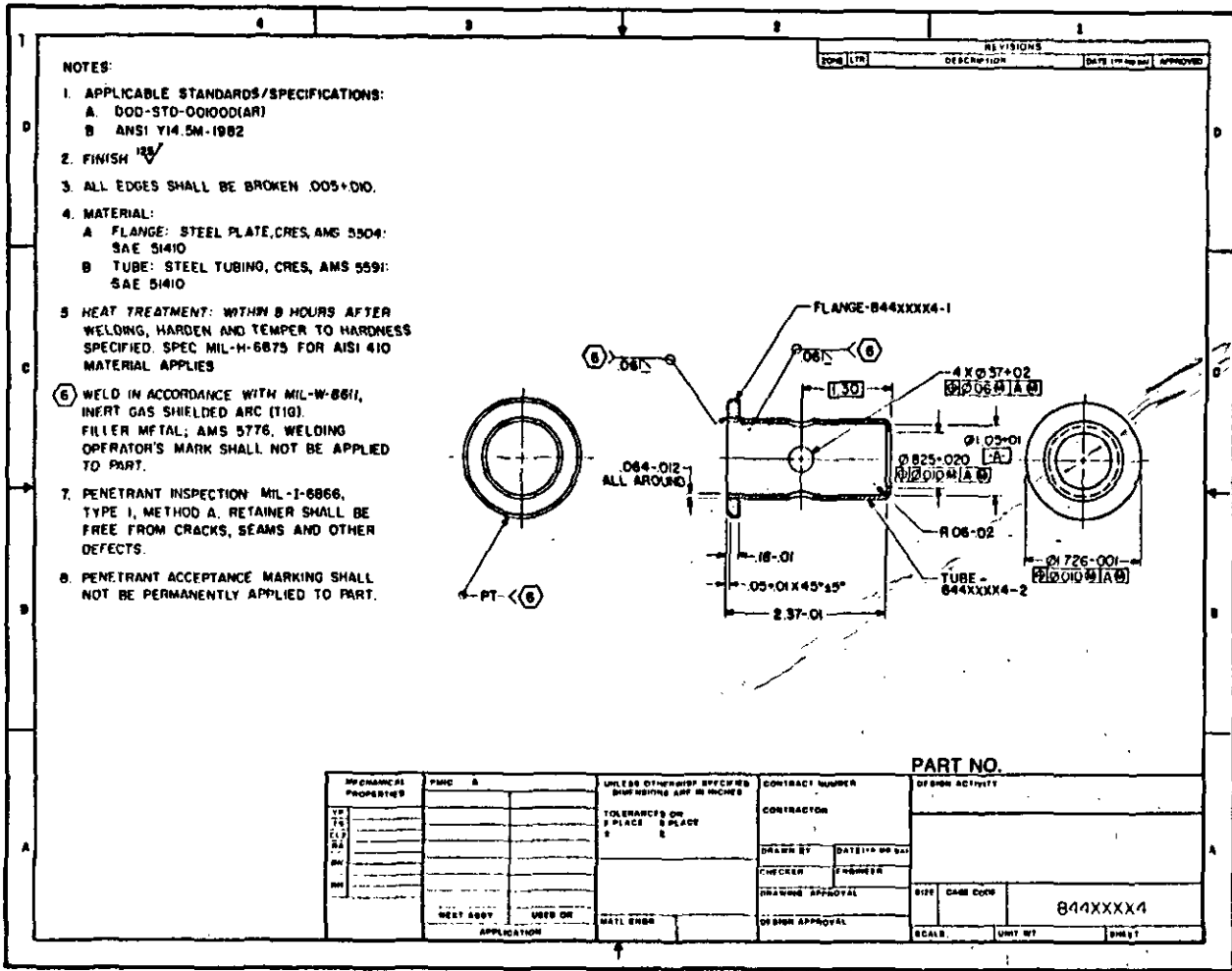

FIGURE 200-9. Inseparable assembly drawing

This sample drawing is informational only and complete to the degree necessary to illustrate a type of drawing. Actual format and drawing shall conform to the textual requirements set forth in this standard.

DOD-STD-00100D(AR)

201.3.5 Installation assembly drawing. An installation assembly drawing shows the installed and assembled position of an item(s) relative to its supporting structure or to associated items. Installation assembly drawings for vehicle applications shall be used to depict the installation of items forming a separate vehicle sub-system such as hydraulic, electrical, brake, steering, and suspension. If a detail or assembly, not a part of the installation, is shown for clarity or related items or position, the detail or assembly shall be shown in phantom. There will be no part number above the title block. See Appendix D.

201.3.5.1 Requirements. An installation assembly drawing shall include the following, as applicable:

- a. Listing of items to be installed.
- b. Locating dimensions and associated tolerances.
- c. Types and quantities of attachment.
- d. Process and special installation requirements.
- e. Adjustment data.
- f. Special test or inspection requirements.
- g. Detail definition of special installation parts.

NOTE: Such drawings are used to install and assemble bellcranks, electrical wiring harnesses, tubing, etc., into the supporting structure of the end-product*.

201.3.6 Exploded assembly drawing. An exploded assembly drawing, using either isometric or perspective drawing techniques, depicts the individual items that make up a part in a manner whereby they are separated from each other but related to each other by the use of a center line. The use of exploded assembly drawings require prior approval of the responsible Government Design Agency.

201.3.6.1 Requirements. An exploded assembly drawing may be used to illustrate a particular requirement which necessitates the delineation of a part in either assembly or disassembly arrangement. They are usually required for illustrated parts breakdown or provisioning.

201.3.7 Matched parts drawing. A matched parts drawing depicts parts which are machine matched, or otherwise mated, and for which replacement as a matched set or pair is essential. See FIGURE 200-10.

DOD-STD-00100D(AR)

201.3.7.1 Requirements. The operating or mating characteristics of the matched parts (set) shall be stated. The matched parts may be detailed on the matched parts drawing or on separate drawings. A single part number shall be assigned to each of the matched parts and to the matched pair or set; the drawing shall require unique identification marking of the matched set. ***FURNISH ONLY AS A MATCHED SET*** or a similar note shall be on the drawing.

a. When Monodetail drawing concept is used, the note shall be applied to each of the drawings including the assembly drawings. The unique identification marking of the matched set shall be a serial number composed as specified in 108.1.2.

b. Matched parts drawings shall have the following specified in the general notes:

"ASSEMBLY SHALL BE MANUFACTURED, INSPECTED, PACKAGED OR ASSEMBLED, STOCKED OR REPLACED, PERMANENTLY IDENTIFIED AND RETAINED AS A SERIALIZED MATCHED SET."

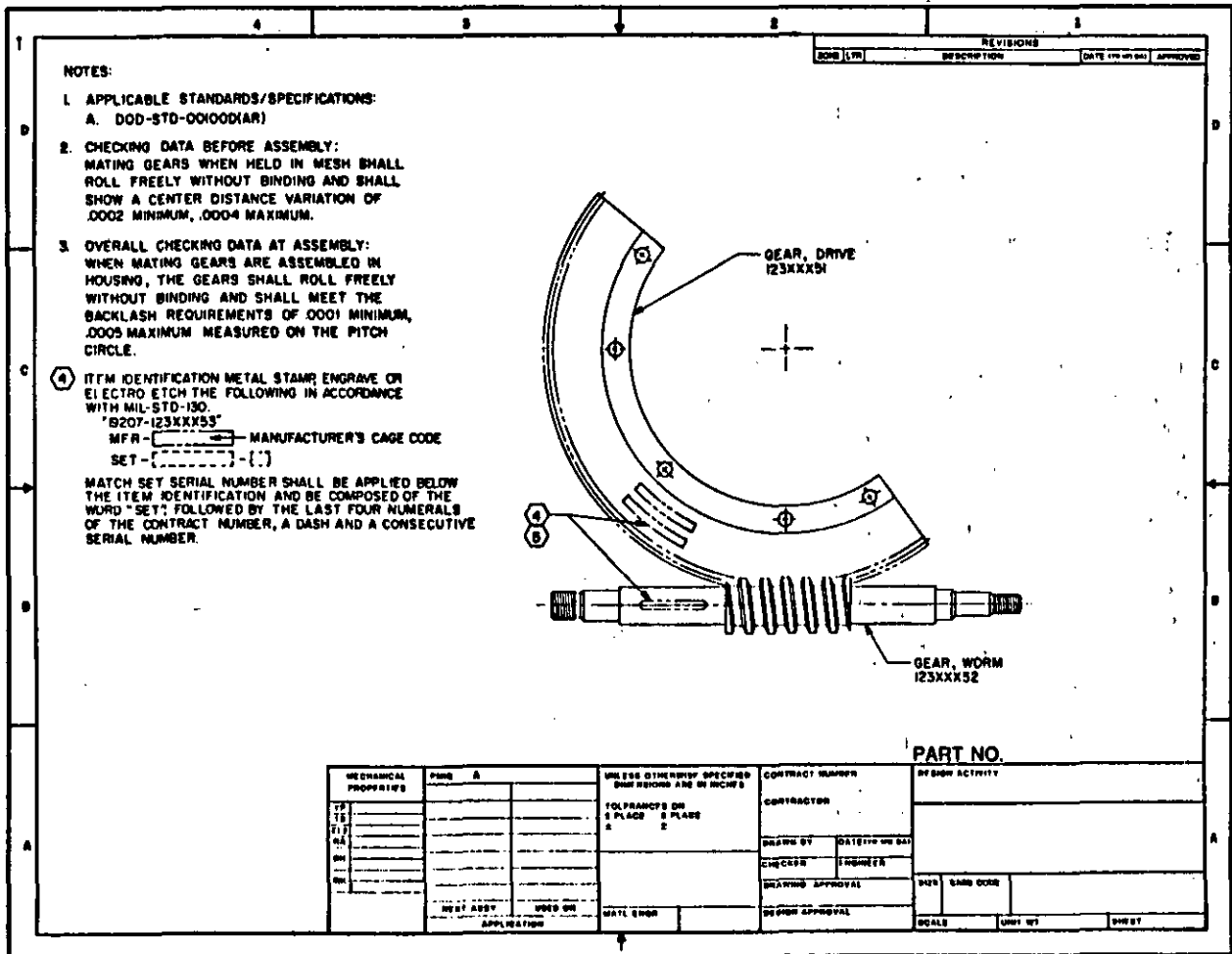

FIGURE 200-10. Matched parts drawing

This sample drawing is informational only and complete to the degree necessary to illustrate a type of drawing. Actual format and drawing shall conform to the textual requirements set forth in this standard.

DOD-STD-00100D(AR)

201.3.8 Arrangement drawing. An arrangement drawing is a drawing that depicts in any projection or perspective drawing technique, with or without controlling dimensions, the relationship of major units of the item depicted. See FIGURE 200-11.

201.3.8.1 Requirements. An arrangement drawing shall show sufficient views of the item so that a general understanding is conveyed of the configuration and location of major units. Overall, locating and other general dimensions necessary to define the configuration may be shown. Major units shall be identified.

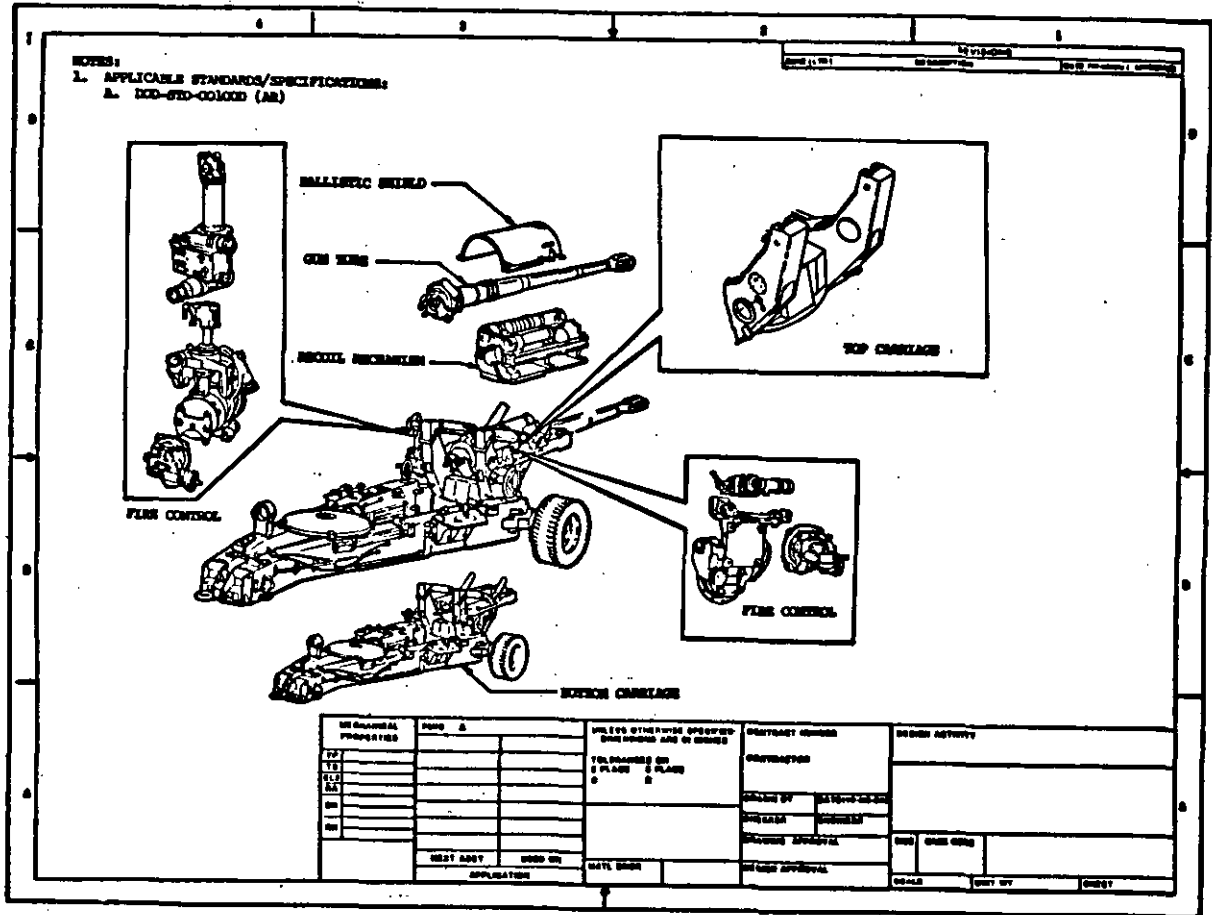

FIGURE 200-11. Arrangement drawing

This sample drawing is informational only and complete to the degree necessary to illustrate a type of drawing. Actual format and drawing shall conform to the textual requirements set forth in this standard.

DOD-STD-00100D(AR)

201.4 Control drawing. A control drawing is an engineering drawing that defines configuration and configuration limitations; performance, test, inspection and acceptance requirements, weight and space limitations; access clearance, pipe and cable attachments, etc., to the extent necessary to ensure function in a particular application and so that an item can be developed or acquired in the commercial market to the requirements stated on the drawing or in a detail specification supporting the drawing. Also, for the installation and co-functioning of an item to be installed/used with related items. Control drawings are identified as envelope, specification control, source control, altered item, selected item, interface control and installation control.

NOTE 1: Control drawings of items that are subjected to alteration or selection as defined by Altered and Selected Item drawings (paragraph 201.4.4 and 201.4.5) shall be annotated with the following applicable note:

a. For Altered Items.

"ALL VENDORS' ITEMS SHALL BE CAPABLE OF ALTERATION AS SPECIFIED ON DWG (*Altered Item No.*) WITHOUT ADVERSE EFFECT ON REQUIREMENTS OF THIS DRAWING."

b. For Selected Items.

"ALL VENDORS' ITEMS SHALL BE CAPABLE OF SELECTION AS SPECIFIED ON DWG (*Selected Item No.*)"

201.4.1 Envelope drawing. An envelope drawing defines an item where all characteristics, other than those shown on the drawing, are left to the ingenuity of the producer in order to meet the specified performance and design requirements. The notation **ENVELOPE DRAWING** shall be placed above the title block.

NOTE 1: The term "performance requirements" means a listing of those physical and functional characteristics under specified operating conditions (loads, speeds, etc.) and environmental conditions, as required, to fully describe the essential operating characteristics under which the item must operate and perform. The characteristics so listed shall be defined to the degree that interchangeability of substitute items produced by any manufacturer is assured if the specified performance is possessed by these items.

NOTE 2: The term "design requirements" means the minimum performance requirements an item must meet in order to satisfy system functional performance requirements.

201.4.1.1 Requirements. Envelope drawing disclosure requirements are identical to those for Specification Control drawings, paragraph 201.4.2.1.

NOTE 1: When development is completed, an envelope drawing shall evolve into a set of complete design disclosure drawings, a Government specification, or if source(s) of supply are established, into a specification or source control drawing. Envelope drawings shall not be used for the Product Configuration Identification.* See FIGURE 200-12.

DOD-STD-00100D(AR)

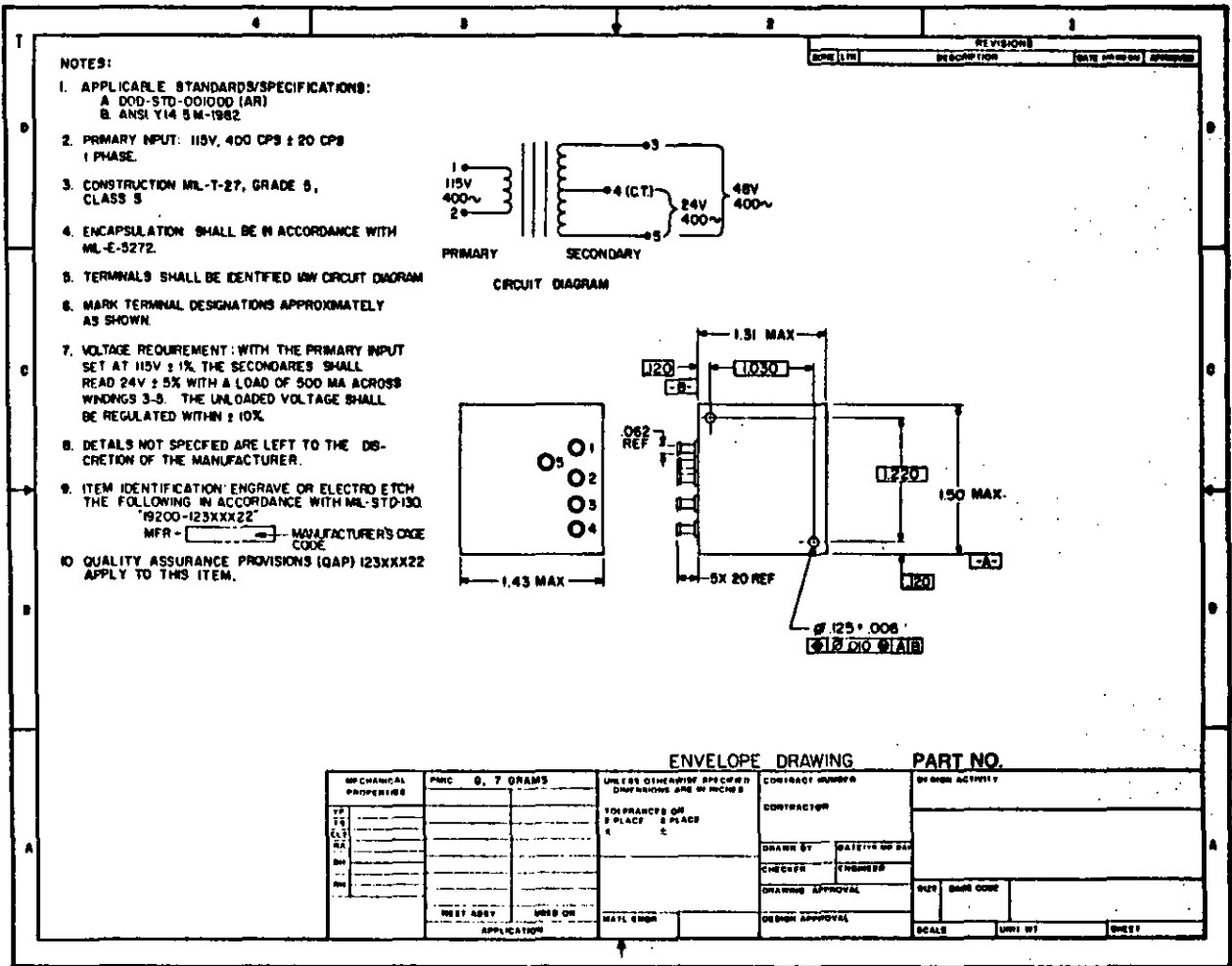

FIGURE 200-12. Envelope drawing

This sample drawing is informational only and complete to the degree necessary to illustrate a type of drawing. Actual format and drawing shall conform to the textual requirements set forth in this standard.

DOD-STD-00100D(AR)

201.4.2 Specification control drawing. A specification control drawing defines an item that was previously shown on an envelope drawing, a source control drawings or that is an existing commercial* item or vendor*-developed item. The commercial or vendor-developed item that is advertised or catalogued as available on an unrestricted basis on order or as an off-the-shelf item or an item, while not commercially available, must be available on order from a specialized segment of industry. The drawing, under the heading "SUGGESTED SOURCE(S) OF SUPPLY*" shall list the name (and address if known), manufacturer's CAGE Code and item identification number of two or more known sources unless, after a search it is determined that there is only one source. Quality conformance inspection and approval requirements shall be specified in a separate document referenced on the drawing. In addition, the notation "SPECIFICATION CONTROL DRAWING" shall be placed above the title block. See FIGURE 200-13. The following note shall appear in the body of the drawing.

IDENTIFICATION OF THE SUGGESTED SOURCE(S) OF SUPPLY HEREON IS NOT TO BE CONSTRUED AS A GUARANTEE OF PRESENT OR CONTINUED AVAILABILITY AS A SOURCE OF SUPPLY FOR THE ITEM(S)

NOTE 1: The suggested source(s) listed on a specification control drawing are not intended to represent the only source(s) for the item.

NOTE 2: Qualification testing of items is not a prerequisite for inclusion of another vendor's item. However, any items must be capable of meeting all of the specified requirements. If such pre-qualification and approval is necessary, the item should be defined on a source control drawing.

NOTE 3: Vendor*-developed items are those products of industries which normally provide customer application engineering services for a commercial product line, and their products are commercially available from a specialized segment of an industry. Typical examples of such items are: special motors, synchros, transformers, potentiometers, hydraulic valves, carburetors, potted servo-amplifiers, keyboards and tape readers.

NOTE 4: Altered items, selected items and items defined in Federal, Military and recognized non-government standards or specifications shall not be delineated on specification control drawings.

NOTE 5: Specification control drawings shall not be used to define commercial or vendor-developed items upon which a design activity has placed requirements that the item in its advertised form may not be capable of meeting and/or has not been subjected to tests during the development of the end item/system. These kinds of items shall be defined on either altered or selected item drawings as appropriate. Commercial or vendor-developed items that were used in development and successfully met the end item/system requirements shall be described by performance and design requirements necessary to ensure acceptable form, fit and function that is compatible with their final end item/system use. These requirements are necessary to ensure that items acquired in the future are essentially the same as those used in the end item/system development. They also provide complete definition for acceptance of additional sources of supply.

DOD-STD-00100D(AR)

NOTE 6: It is not intended that this standard, by itself, cause preparation of specification control drawings for all applicable vendor items. Preparation criteria for engineering drawings is governed by the contract or order.

NOTE 7: Preparation of Specification Control drawings requires prior approval of the Government Design Activity.

NOTE 8: Specification control drawings may be prepared only for items which will not normally require replacement of any of their component parts during the life of the item. Any exception to this requirement will require that separate drawings be prepared for each repair part not already covered by other drawings, government or non-government specifications and standards.

NOTE 9: Specification control drawings shall not be prepared in circumstances where a Military Detail Specification would be more appropriate.

NOTE 10: Specification control data shall not be tailored to the characteristics of a single vendor's product to the exclusion of other equally suitable products. Conversely, specification data shall not be so broad as to permit acceptance of products which will not perform in the equipment under all required environmental conditions.

201.4.2.1 Requirements. A specification control drawing shall disclose as applicable, configuration, dimensions of envelope, mounting and mating dimensions, interface dimensional characteristics, and limits thereto. In addition, as necessary, inspection and acceptance test requirements, performance, reliability, maintainability, environmental and other functional requirements, to insure identification and adequate reprourement of an interchangeable item. If an electrical or electronics (or other engineering) circuit is involved, a schematic and connection or other appropriate diagrammatic disclosure shall be included on the drawing (or referenced thereon), thereby providing sufficient information for making external connections.

DOD-STD-00100D(AR)

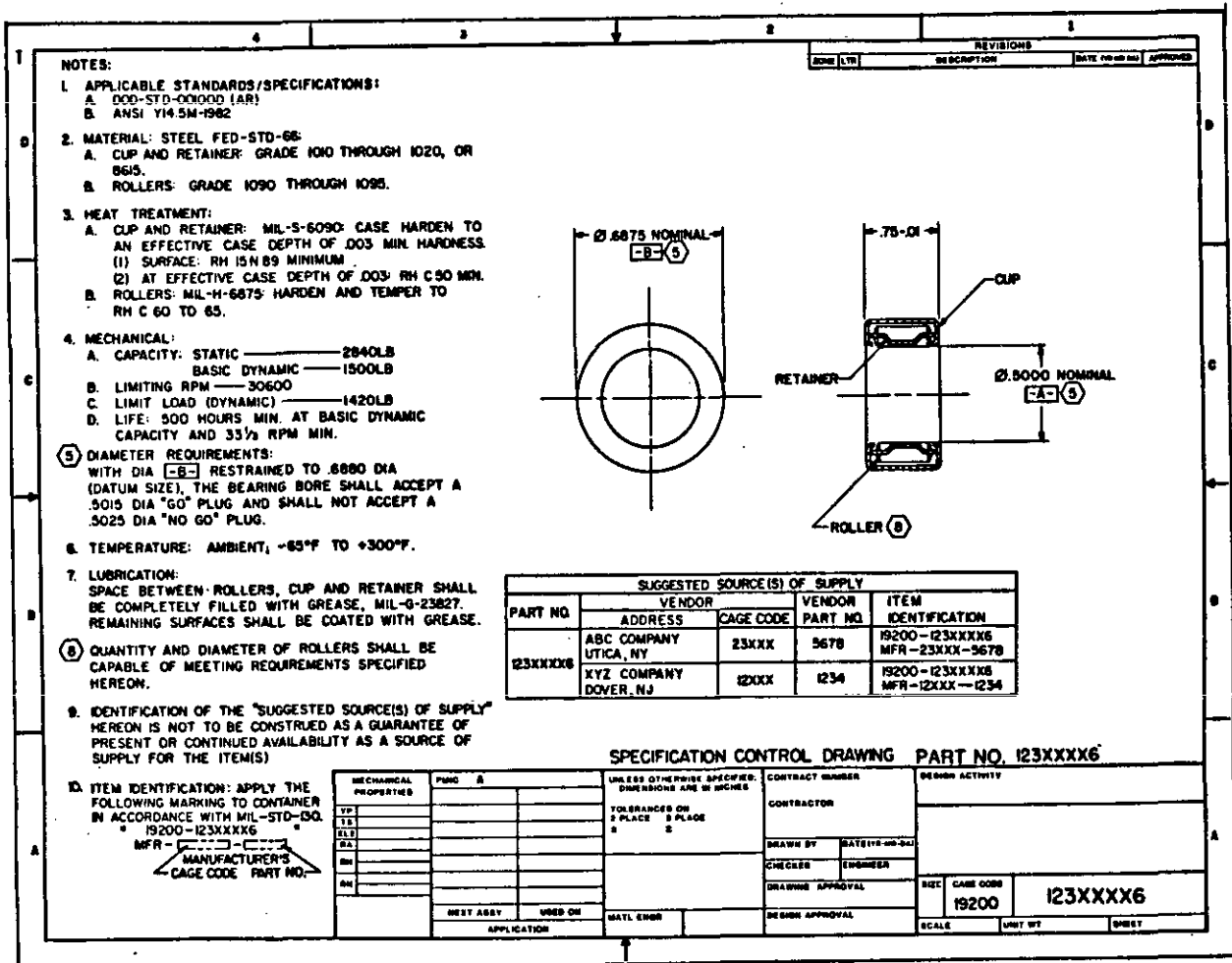

81

FIGURE 200-13. Specification control drawing

This sample drawing is informational only and complete to the degree necessary to illustrate a type of drawing. Actual format and drawing shall conform to the textual requirements set forth in this standard.

201.4.3 Source control drawing. A source control drawing defines an item that was previously shown on an envelope drawing or an existing commercial* or vendor* item which is the only known item which exclusively provides the performance, installation and interchangeable characteristics required for a specific critical application. Quality conformance inspection, qualification testing and approval requirements shall be specified in a separate document referenced on the drawing. The drawing shall include the following notations.

"ONLY THE ITEM DESCRIBED ON THIS DRAWING WHEN PROCURED FROM THE VENDOR(S) LISTED HEREON IS APPROVED BY (Name and Address of Cognizant Design Activity) FOR USE IN THE APPLICATION(S) SPECIFIED HEREON. A SUBSTITUTE ITEM SHALL NOT BE USED WITHOUT PRIOR APPROVAL BY (Name of Cognizant Design Activity)."

"IDENTIFICATION OF THE APPROVED SOURCE(S) OF SUPPLY HEREON IS NOT TO BE CONSTRUED AS A GUARANTEE OF PRESENT OR CONTINUED AVAILABILITY AS A SOURCE OF SUPPLY FOR THE ITEM DESCRIBED ON THE DRAWING."

The drawing shall include under the heading "APPROVED SOURCE(S) OF SUPPLY" the manufacturer's name, address, CAGE Code and item identification number of each item that has been tested and approved for use in the specific applications stated on the drawing in the application block. In addition, "SOURCE CONTROL DRAWING" shall be shown above the title block. The item(s) thus disclosed shall be identified in all subsequent actions (including procurement) by the source control drawing number. See paragraph 402.10, Note 2. Whenever another vendor's item is qualified for the stated applications or when a new critical application is found and all vendor items that are cited on the drawing are approved for use in the new critical application, the drawing shall be revised, rather than a new drawing issued to show the new vendor or application. Each new vendor added must be approved for all stated applications. See FIGURE 200-14a and FIGURE 200-14b.

NOTE 1: Altered items, selected items and those defined in Government and recognized non-government (industrial society) specifications or standards shall not be delineated on source control drawings.

NOTE 2: Qualification testing and approval of items is a prerequisite for inclusion of another vendor's item on a source control drawing. It should be noted that an item defined on a source control drawing is not in itself justification for other than competitive procurement and may be solicited on the open market. Therefore, it is imperative that complete performance and design requirements be specified.

NOTE 3: Preparation of Source Control drawings requires prior approval of the Government Design Activity. Source control drawings shall not be used for items only available from the development contractor unless the intent to do so was previously accepted by the Government as a condition of that contract.

DOD-STD-00100D(AR)

NOTE 4: When a source control item has repairable parts, those parts shall be identified and/or listed on the drawing. Separate government drawings shall be prepared for repair parts not already covered by other government drawings, government or recognized non-government specifications or standards.

NOTE 5: Privately developed items, such as items defined as patented, proprietary or with limited rights shall only be used in accordance with contract requirements and prior approval of the Government Design Activity.

NOTE 6: The name of the cognizant design activity in the approval note (paragraph 201.4.3) shall be:

a. For Armament, Munitions, Tools and Equipment items:

"U.S. ARMY ARMAMENT RESEARCH, DEVELOPMENT AND ENGINEERING CENTER"

b. For Chemical items:

"U.S. ARMY CHEMICAL RESEARCH, DEVELOPMENT AND ENGINEERING CENTER"

c. For Tank-Automotive items:

"U.S. ARMY TANK-AUTOMOTIVE COMMAND"

NOTE 7: Address of Government Design Activity. The address of the cognizant design activity in the approval note shall be for drawings with CAGE Codes as follows:

a. For 19200 - "PICATINNY ARSENAL, NJ 07806-5000"

b. For 19204 - "ROCK ISLAND, IL 61299-5000"

c. For 19206 - "WATERVLIET, NY 12189-4Q50"

d. For 19207 - "WARREN, MI 48397-5000"

e. For 59678 - "ROCK ISLAND, IL 61299-5000"

f. For 81361 - "ABERDEEN PROVING GROUND, MD 21010-5423"

201.4.3.1 Requirements. Source control drawing disclosure requirements are identical to those for specification control drawings, paragraph 201.4.2.1.

DOD-STD-00100D(AR)

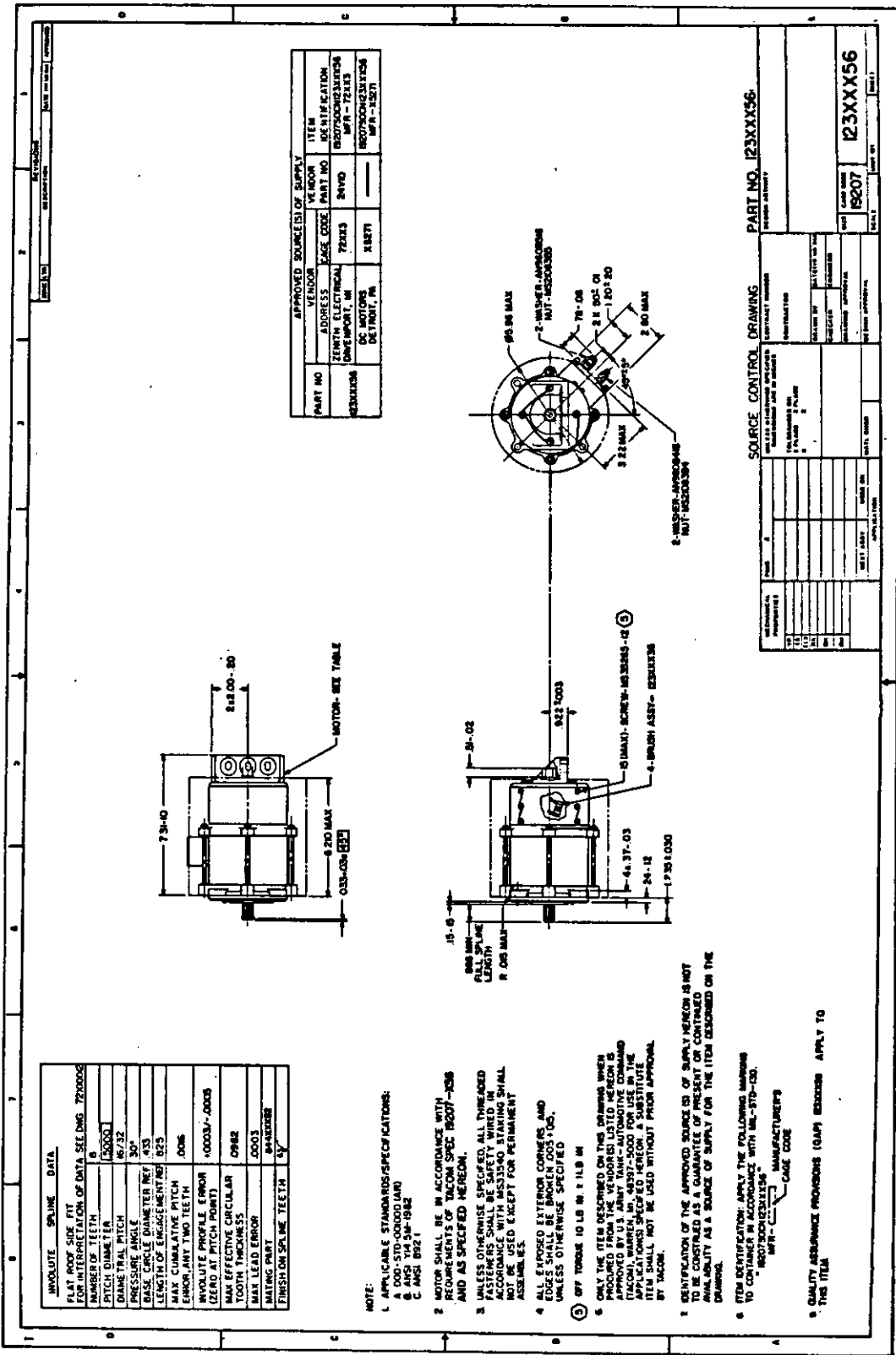

FIGURE 200-14a. Source control drawing (with replaceable parts)

84

This sample drawing is informational only and complete to the degree necessary to illustrate a type of drawing. Actual format and drawing shall conform to the textual requirements set forth in this standard.

DOD-STD-00100D(AR)

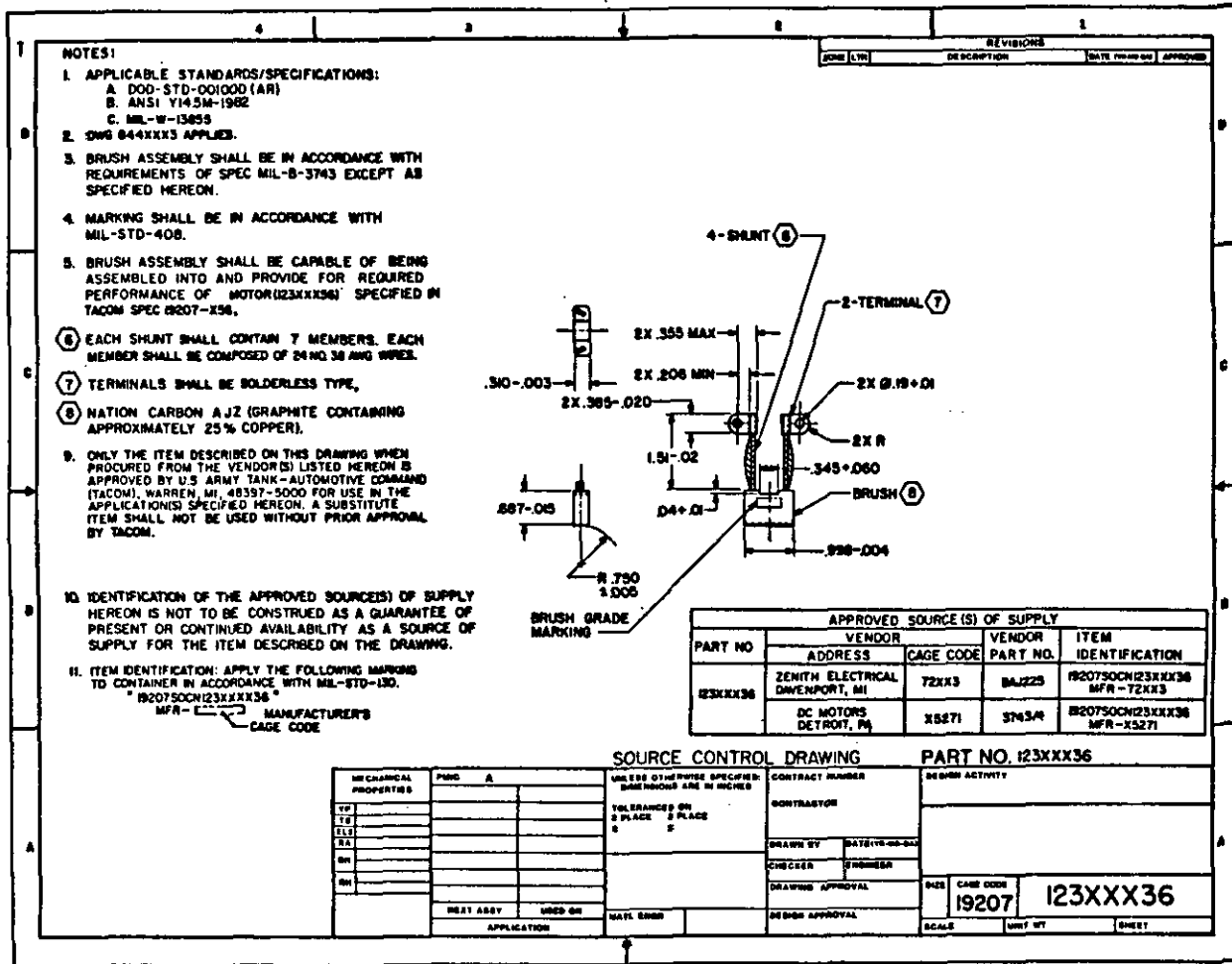

FIGURE 200-14b. Source control drawing (replacement part)

This sample drawing is informational only and complete to the degree necessary to illustrate a type of drawing. Actual format and drawing shall conform to the textual requirements set forth in this standard.

DOD-STD-00100D(AR)

201.4.4 Altered item drawing. When the design of an item is to be altered, the requirements for the alteration shall be specified on an altered item drawing. The drawing shall describe the item without and with alteration. Commercial and vendor-developed items shall be completely defined, either on the altered item drawing or separately by complete design disclosure/specification control/source control as appropriate. Items with multiple sources that, due to configuration differences, require a different alteration, shall be defined on the same altered item drawing where possible with sufficient description to define the alteration for each vendor's item provided.

a. Altered items are physically and functionally interchangeable.

b. Items prior to alteration are completely defined on the same drawing or another drawing.

Items not meeting the preceding criteria shall be defined on separate altered item drawings. Quality conformance inspection and approval requirements shall be specified in a separate document that is referenced on the altered item drawing. See FIGURES 15 and 200-48.

201.4.4.1 Requirements. An Altered item drawing shall delineate the complete details of the alteration in terms of final configuration. The drawing shall define "what" the alteration is and included necessary information to identify the item without alteration, including the original identifying part number and, if a commercial or vendor-developed item, the original manufacturer's name, address if known, and CAGE Code. This information shall be shown on the altered item drawing or on separate supporting drawings, (specification control/source control) if available. The name and address of the source need not be specified if the original part is a Government or recognized non-government standard item. The notation, "ALTERED ITEM DRAWING" shall be applied above the title block. The identification of the item so depicted shall be in accordance with paragraph 402.10e.

NOTE 1: The following general note shall be used:

"Name of Item SHALL BE IN ACCORDANCE WITH REQUIREMENTS OF Drawing/Specification/MS Part No. etc. EXCEPT AS SPECIFIED HEREON."

or

if all requirements are specified on the altered item drawing:

Note number
 **"ALTERED FEATURE(S)"**

DOD-STD-00100D(AR)

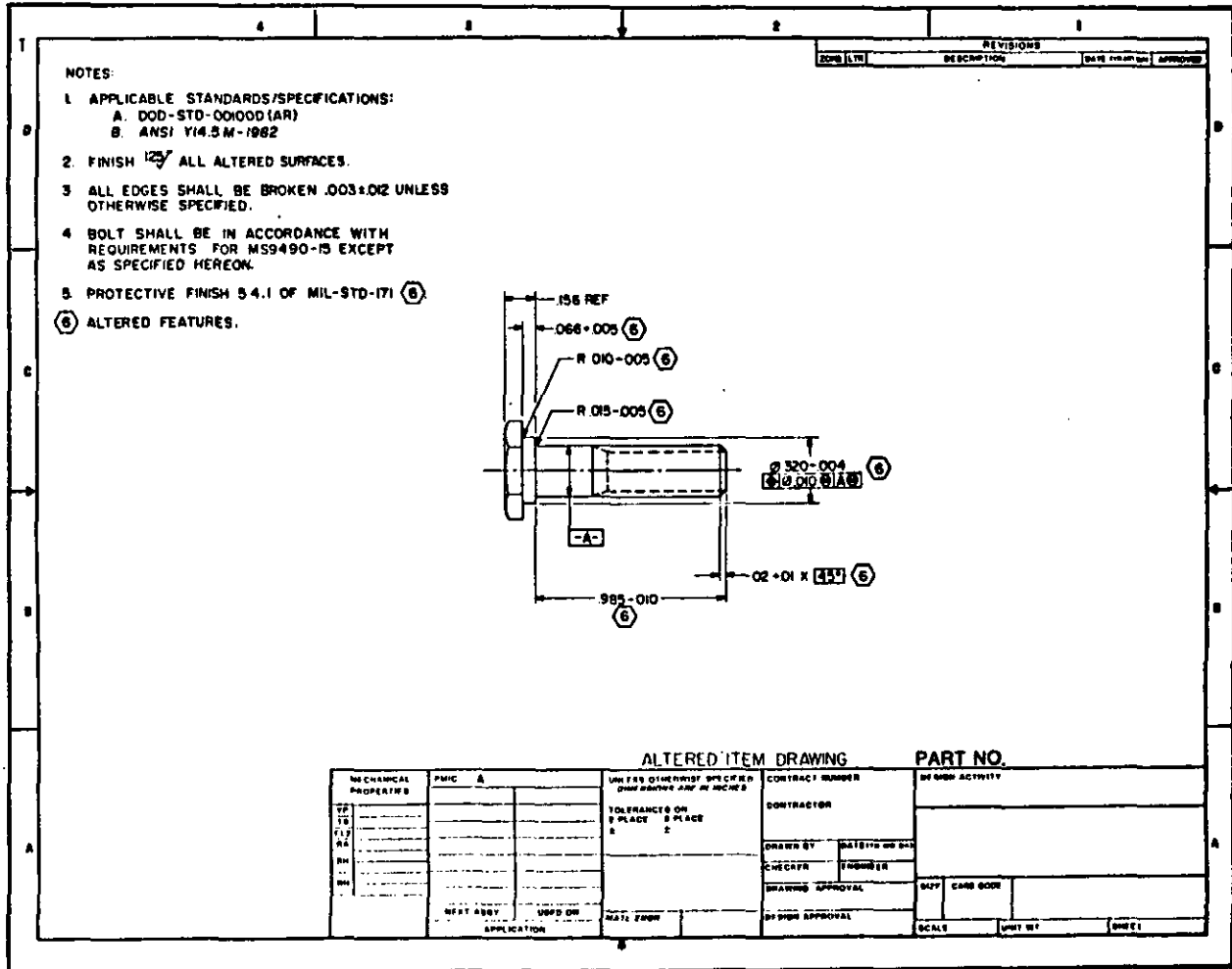

FIGURE 200-15. Altered item drawing (part controlled by Military Standard)

This sample drawing is informational only and complete to the degree necessary to illustrate a type of drawing. Actual format and drawing shall conform to the textual requirements set forth in this standard.

DOD-STD-00100D(AR)

201.4.5 Selected item drawing. A Selected item drawing defines an existing standard, commercial or vendor-developed item with further required selection or restriction for fit, tolerance, performance or reliability within the range, or limits, inherent in that item. The drawing shall completely describe: the item prior to selection and; the requirements for selection. Commercial and vendor-developed items shall be completely defined on the Selected item drawing or separately by complete design disclosure/specification control/source control as appropriate. Quality conformance inspection and approval requirements shall be specified in a separate document that is referenced on the selected item drawing. Although physical modification of the design is not necessary, the item, by virtue of selected requirements is different than that from which the selection is made. See FIGURE 200-16.

201.4.5.1 Requirements. A Selected item drawing shall delineate the complete details on which selection of the item is predicated with a full disclosure of the range or limit restrictions for fit, tolerance, performance or reliability. The drawing shall include all necessary information to identify the item prior to its selection, including the original identifying part number and, if a commercial or vendor-developed item, the original manufacturer's name, address if known and CAGE Code. This information shall be shown on the selected item drawing or on separate supporting drawings, (specification control/source control) if available. The name and address of the source need not be specified if the original part is a Government or recognized non-government standard item. The notation, "SELECTED ITEM DRAWING" shall be applied adjacent to the title block. The identification of the item so depicted shall be in accordance with paragraph 402.10e.

NOTE 1: The following general note shall be used:

" Name of Item: SHALL BE IN ACCORDANCE WITH REQUIREMENTS OF Drawing/Specification/MS Part No. etc. EXCEPT AS SPECIFIED HEREON."

or

if all requirements are specified on the selected item drawing:

Note number
 "① SELECTED FEATURE(S)"

DOD-STD-00100D(AR)

		4		3		2		1	
								REVISIONS	
						DATE	BY	APPROVED	
<p>NOTES:</p> <p>1. APPLICABLE STANDARDS/SPECIFICATIONS: A. DOD-STD-00100D (AR) B. ANSI Y14.5M-1982</p> <p>2. BOLT SHALL BE IN ACCORDANCE WITH REQUIREMENTS FOR AN4C-II EXCEPT AS SPECIFIED HEREON.</p> <p>3. ITEM IDENTIFICATION: APPLY THE FOLLOWING MARKING TO CONTAINER IN ACCORDANCE WITH MIL-STD-130. "19207-123XXXX2" MFR. [] → MANUFACTURER'S CAGE CODE</p> <p>4. QUALITY ASSURANCE PROVISIONS (QAP) 123XXXX2 APPLY TO THIS ITEM.</p>									
									
SELECTED ITEM DRAWING				PART NO.					
MECHANICAL PROPERTIES		FORM A		UNLESS OTHERWISE SPECIFIED DIMENSIONS ARE IN INCHES		CONTRACT NUMBER		DESIGN ACTIVITY	
TP				TOLERANCES ON		CONTRACTOR			
TS				2 PLACE	3 PLACE	DRAWN BY DATE (YY MM DD)			
FLL						CHECKER ENGINEER			
OS						DRAWING APPROVAL		SIZE	DATE CODE
SH						DESIGN APPROVAL			
SN						SCALE		UNIT BY	SHEET

FIGURE 200-16. Selected item drawing (part controlled by Military Standard)

This sample drawing is informational only and complete to the degree necessary to illustrate a type of drawing. Actual format and drawing shall conform to the textual requirements set forth in this standard.

DOD-STD-00100D(AR)

201.4.6 Interface control drawing. An interface control drawing depicts physical and functional interface engineering requirements of an item which affect the design or operation of co-functioning items. These drawings are used as design control documents, delineating interface engineering data coordinated for purpose of: (a) establishing and maintaining compatibility between co-functioning items; (b) controlling interface designs thereby preventing changes to each item's requirements which would affect compatibility with co-functioning sub-systems; (c) communicating design decisions and changes to participating activities. See FIGURE 200-17.

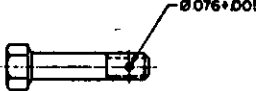
201.4.6.1 Requirements. An interface control drawing shall delineate as necessary: (a) configuration and all interface dimensional data applicable to the envelope, mounting and mating of the items; (b) complete interface engineering requirements, such as mechanical, electrical, electronic, hydraulic, pneumatic, optical, etc., which affect the physical or functional characteristics of co-functioning items; and (c) any other characteristics which cannot be changed without affecting system design criteria. Interface drawings may be categorized as mechanical, electrical, interconnection, configuration and installation, operational sequence requirements, system switching, etc., as necessary. The notation **INTERFACE CONTROL DRAWING** shall be shown adjacent to the title block.

REVISIONS		DATE (MM-DD-YY)	APPROVED
NO.	DATE	DESCRIPTION	

NOTES:

- APPLICABLE STANDARDS/SPECIFICATIONS
 - DOD-STD-00100D (AR)
 - ANSI Y14.5M-1982
- INTERFACE DIMENSION

PROPPELLING CHARGE	PARAMETERS
OVERALL LENGTH	M 3A1 M 203
Ø IN	16.00 16.75
Ø IN	3.00 3.750
PROPPELLANT TYPE	M1 M50A1
WEIGHT, LB (APPROX)	3.3 26.10
NOMINAL WEA. IN	Ø165P Ø78 MP
IGNITION TYPE	BASE CENTRAL
BASE PAD	
IGNITER/WT	3.9 OZ CM 1.0 OZ B.P.
CENTER CORE	NA NC TUBE ALDRN
TYPE / WT	8 P
PORT CHARGE	M14EY P558
PORT Ø X LG. IN MAX	37/12 38
CONT Ø D. IN MAX	6 11/16 6 13/32
PORT WY/LBS	14 18 D/2
CONT ID IN MIN	5 7/8 6 13/16
CONT ROCK LENGTH	33 1/2 34

APPROVAL BLOCK			MECHANICAL PROPERTIES	PUNC. MA	UNLESS OTHERWISE SPECIFIED: DIMENSIONS ARE IN INCHES	CONTRACT NUMBER	DESIGN ACTIVITY
ITEM NO.	SIGNATURE	DATE					
PROP CHARGE		870412	TP		1 INCHES ON 2 PLACES	CONTRACTOR	
CONTAINER		870413	TD		4 PLACES		
			ELC			DRAWN BY DATE (MM-DD-YY)	
			RA			CHECKED ENGINEER	
			BN			DRAWER APPROVAL	SIZE CASE CODE
			EN			DESIGN APPROVAL	SCALE UNIT WT SHEET

FIGURE 200-17. Interface control drawing

This sample drawing is informational only and complete to the degree necessary to illustrate a type of drawing. Actual format and drawing shall conform to the textual requirements set forth in this standard.

DOD-STD-00100D(AR)

201.4.7 Installation control drawing. An installation control drawing sets forth information for an item in terms of area, weight and space, access clearance, draining clearances, pipe and cable attachments required for the installation and co-functioning of the item to be installed with related items. See FIGURE 200-18.

201.4.7.1 Requirements. An installation control drawing shall include the following information as applicable: Overall and principal dimensions in sufficient detail to establish the limits of space in all directions required for installation, operation and servicing. The amount of clearance required to permit the opening of doors or the removal of plug-in units shall be included. Clearance for travel or rotation of any moving parts shall be shown, including the centers of rotation, angles of train in azimuth, elevation and depression, and radii from each pivot to the end of each rotating element involved in clearance determination. In addition, the notation, "INSTALLATION CONTROL DRAWING" shall be shown adjacent to the title block.

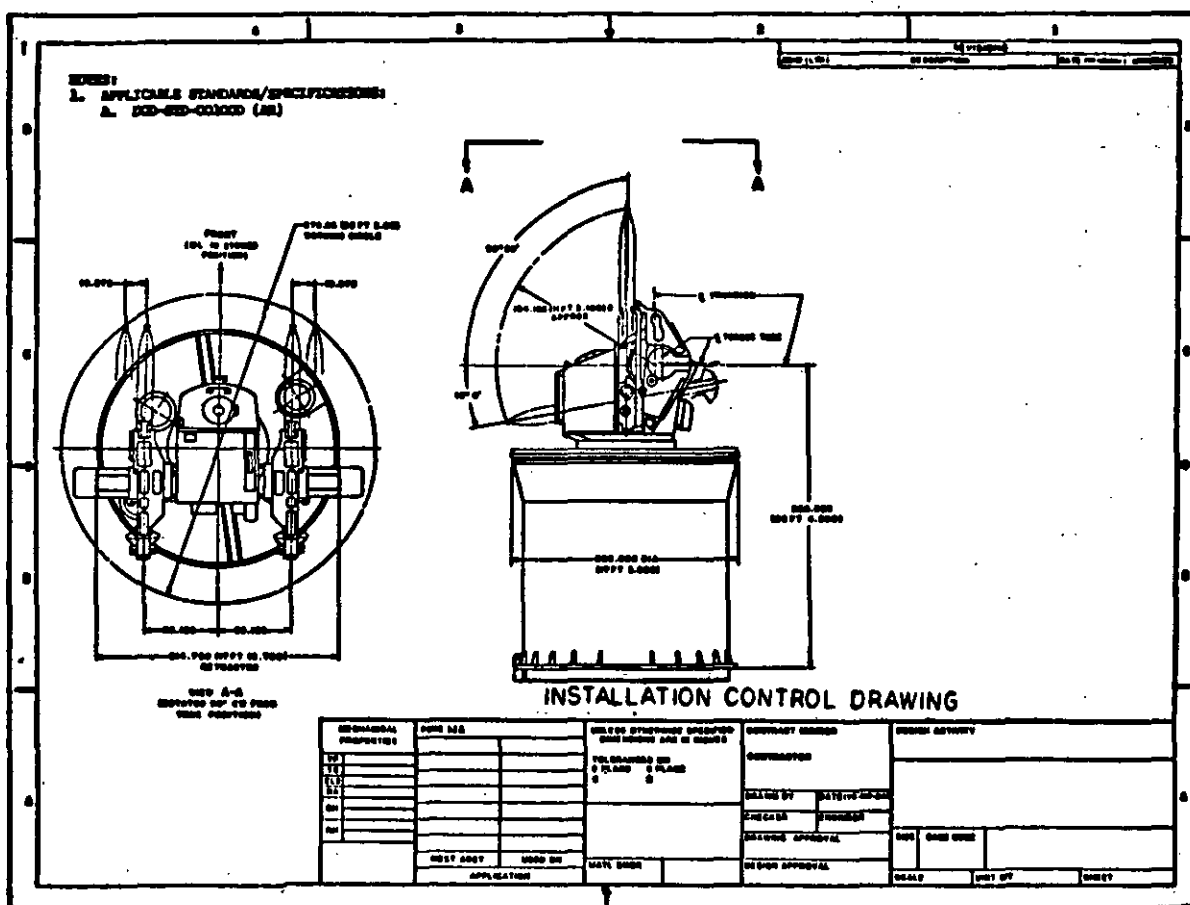

FIGURE 200-18. Installation control drawing

This sample drawing is informational only and complete to the degree necessary to illustrate a type of drawing. Actual format and drawing shall conform to the textual requirements set forth in this standard.

DOD-STD-00100D(AR)

201.5 Installation drawing. An installation drawing shows general configuration and complete information necessary to install an item relative to its supporting structure or to associated items. See FIGURE 200-19. An installation drawing may show a specific completed installation. Installation drawings for one-of-a-kind installation may be revised to record the as-installed or as-built condition.

201.5.1 Requirements. An installation drawing shall include the following as applicable:

- a. Interface mounting and mating information, such as dimensions of location for attaching hardware.
- b. Interface pipe and cable attachments required for the installation and co-functioning of the item to be installed with related items.
- c. Information necessary for preparation of foundation plans, including mounting place details, drilling plans and shock mounting and buffer details.
- d. Location, size and arrangement of ducts.
- e. Weight of unit.
- f. Location, type and dimensions of cable entrances, terminal tubes and electrical connectors.
- g. Interconnecting and cabling data.
- h. Reference notes to applicable lists and assembly drawings.
- i. When not disclosed on an interface control drawing (paragraph 201.4.6) or other reference documents: Overall and principal dimensions in sufficient detail to establish the limits of space in all directions required for installation, operation and servicing; the amount of clearance required to permit the opening of doors or the removal of plug-in units; clearance for travel or rotation of any moving parts, including the centers of rotation and angles of elevation and depression.
- j. An installation drawing may include an integral parts list to indicate the requirements for the installation hardware and if desired, the items being installed.
- k. All lines shown prior to installation shall be in phantom, i.e., outline of basic vehicle.

DOD-STD-00100D(AR)

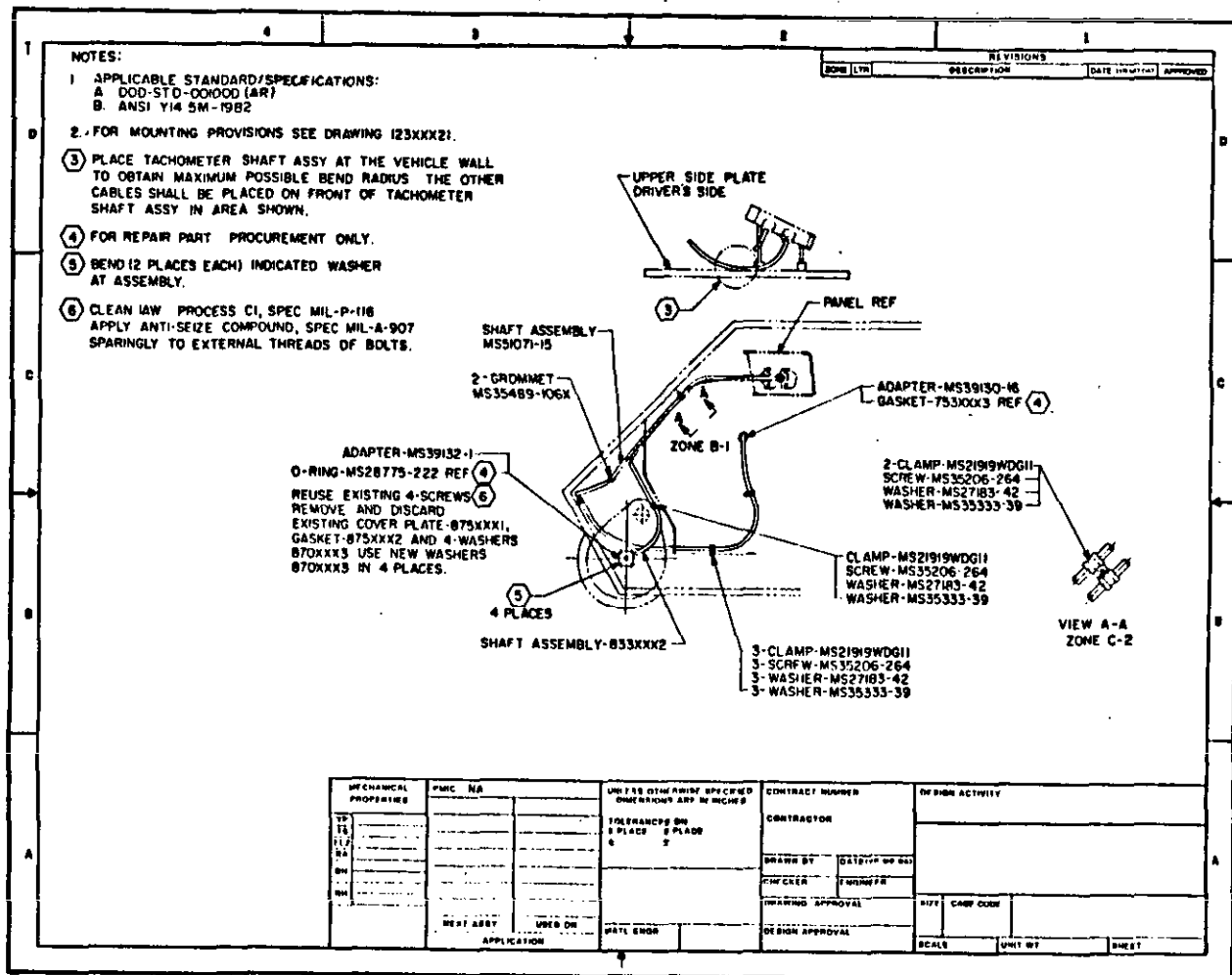

FIGURE 200-19. Installation drawing

This sample drawing is informational only and complete to the degree necessary to illustrate a type of drawing. Actual format and drawing shall conform to the textual requirements set forth in this standard.

DOD-STD-00100D(AR)

201.6 Elevation drawing. An elevation drawing depicts vertical projections of buildings or structures; or profiles of equipment such as aircraft, automotive or marine, or portions of the same. See FIGURE 200-20.

201.6.1 Requirements. As applicable, an elevation drawing shows configuration, shapes and sizes of features, walls, bulkheads, compartments, assignment of space, location and arrangement of machinery or fixed equipment. An elevation drawing may indicate materials of construction.

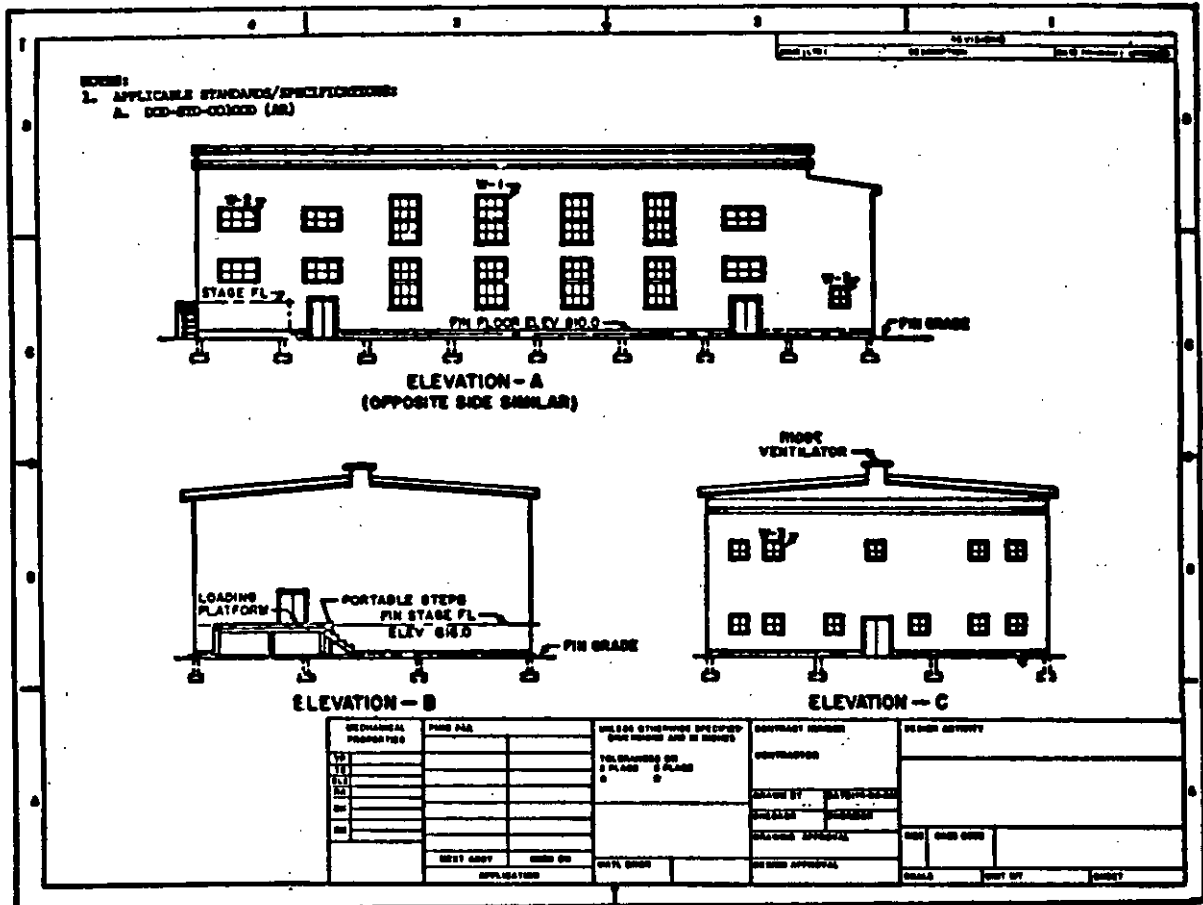

FIGURE 200-20. Elevation drawing

This sample drawing is informational only and complete to the degree necessary to illustrate a type of drawing. Actual format and drawing shall conform to the textual requirements set forth in this standard.

DOD-STD-00100D(AR)

201.7 Diagrammatic drawing. A diagrammatic drawing delineates features and relationships of items forming an assembly or system by means of symbols and lines. A diagrammatic drawing is a graphic explanation of the manner by which an installation, assembly or system (e.g., mechanical, electrical, electronic, hydraulic, pneumatic) performs its intended function. ANSI Y14.15, Y32.9, IEEE STD 315, and MIL-STD-15-2 provide directions for use of symbology relative to diagrammatic drawings.

201.7.1 Schematic diagram. A schematic or elementary diagram shows, by means of graphic symbols, the electrical connections and functions of a specific circuit arrangement. A schematic diagram facilitates tracing the circuit and its functions without regard to the actual physical size, shape, or location of the component devices or parts.

a. A diagrammatic drawing shall be prepared for each electrically functional assembly, i.e., one having a measurable input and output relationship. A connection or wiring diagram, or, for more complex electronic items, a wiring list, shall be prepared for each subassembly state covered by an assembly drawing.

b. Diagrams shall be a part of every system drawing, electrical component drawing, or may be on a separate drawing, but must be referenced on the drawing to which they apply. The schematic identifies circuits and functions. See FIGURE 200-21.

95

DOD-STD-00100D (AR)

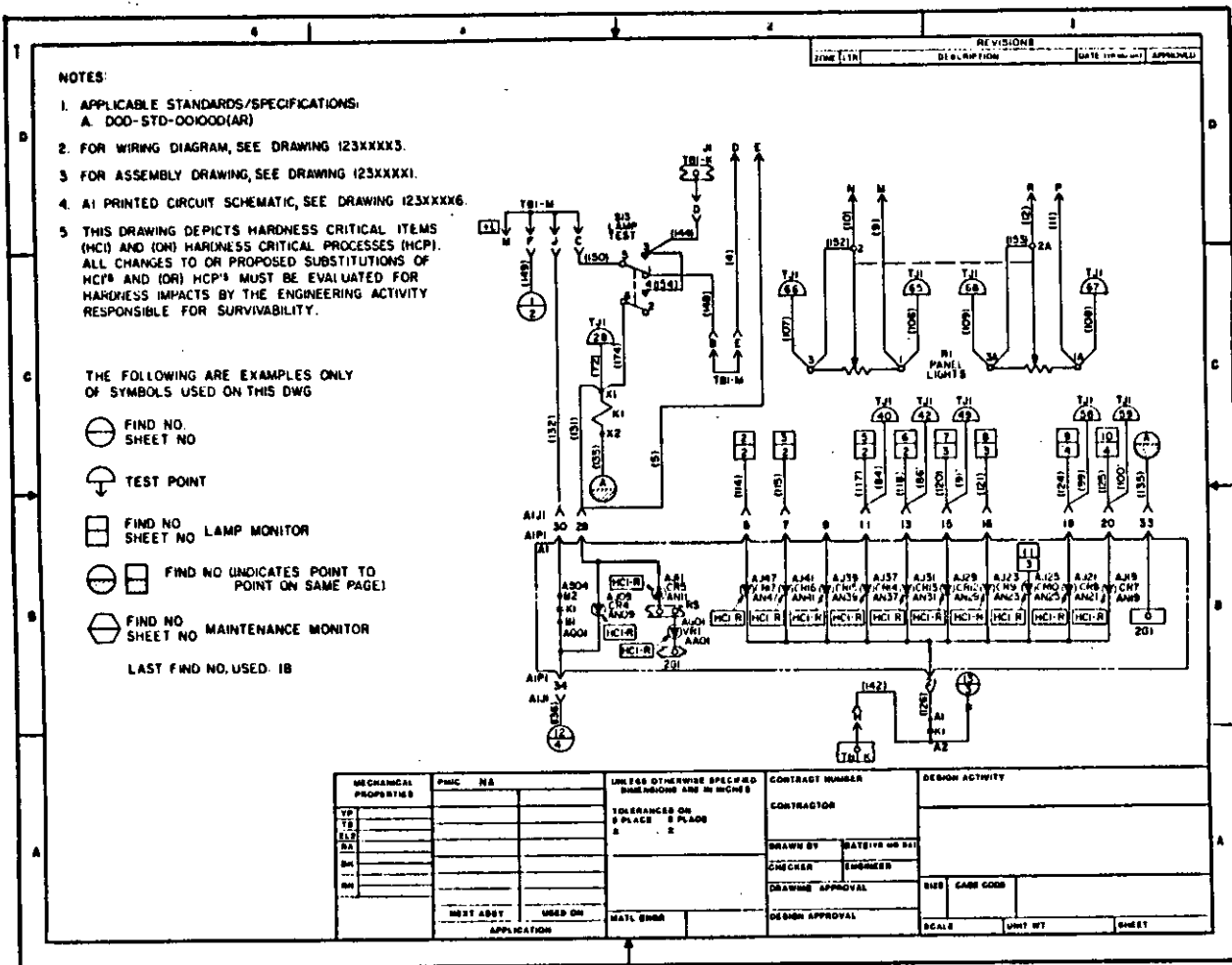

FIGURE 200-21. Schematic diagram drawing

This sample drawing is informational only and complete to the degree necessary to illustrate a type of drawing. Actual format and drawing shall conform to the textual requirements set forth in this standard.

DOD-STD-00100D(AR)

201.7.2 Connection or wiring diagram. Connection or wiring diagrams shall be made for all electrical systems. The drawing shall be a plan view with best posture to show approximate location of connecting components and paths of wire runs along with designations of components. Circuits must be identified in accordance with identifiers on cables, leads, etc. Connectors, components and wire runs shall be identified and/or shown. The diagram may be part of the assembly drawing or a separate drawing. See FIGURE 200-22. A connection or wiring diagram may be prepared in the form of a "wiring list". See FIGURE 200-29f.

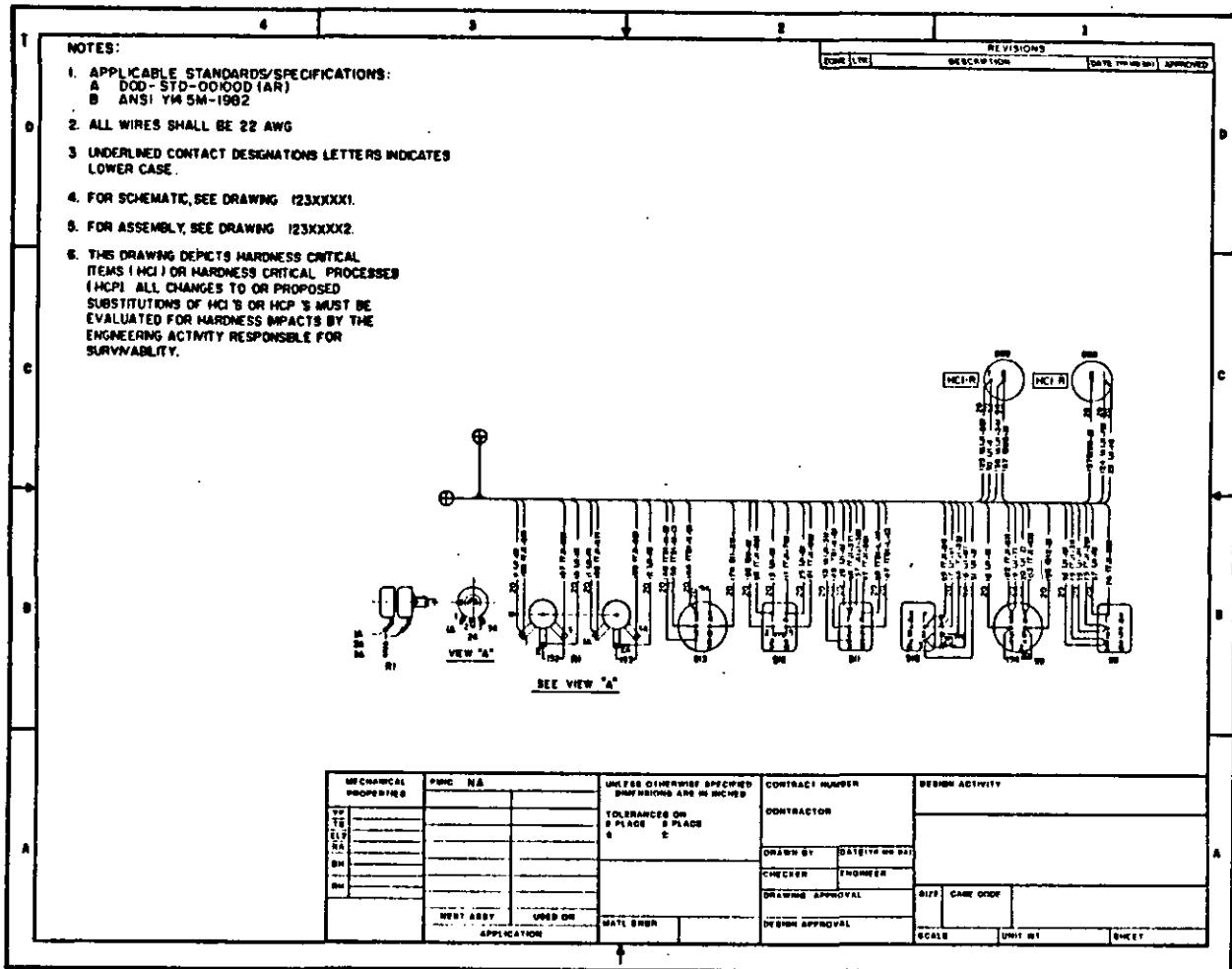

FIGURE 200-22. Connection or wiring diagram drawing

This sample drawing is informational only and complete to the degree necessary to illustrate a type of drawing. Actual format and drawing shall conform to the textual requirements set forth in this standard.

DOD-STD-00100D(AR)

201.7.3 Interconnection diagram. An interconnection diagram is a form of connection or wiring diagram which shows only external connections between units, sets, groups and systems. See paragraph 201.9.2 concerning a form of interconnection diagram known as a wiring list. See FIGURES 200-23a and 200-23b.

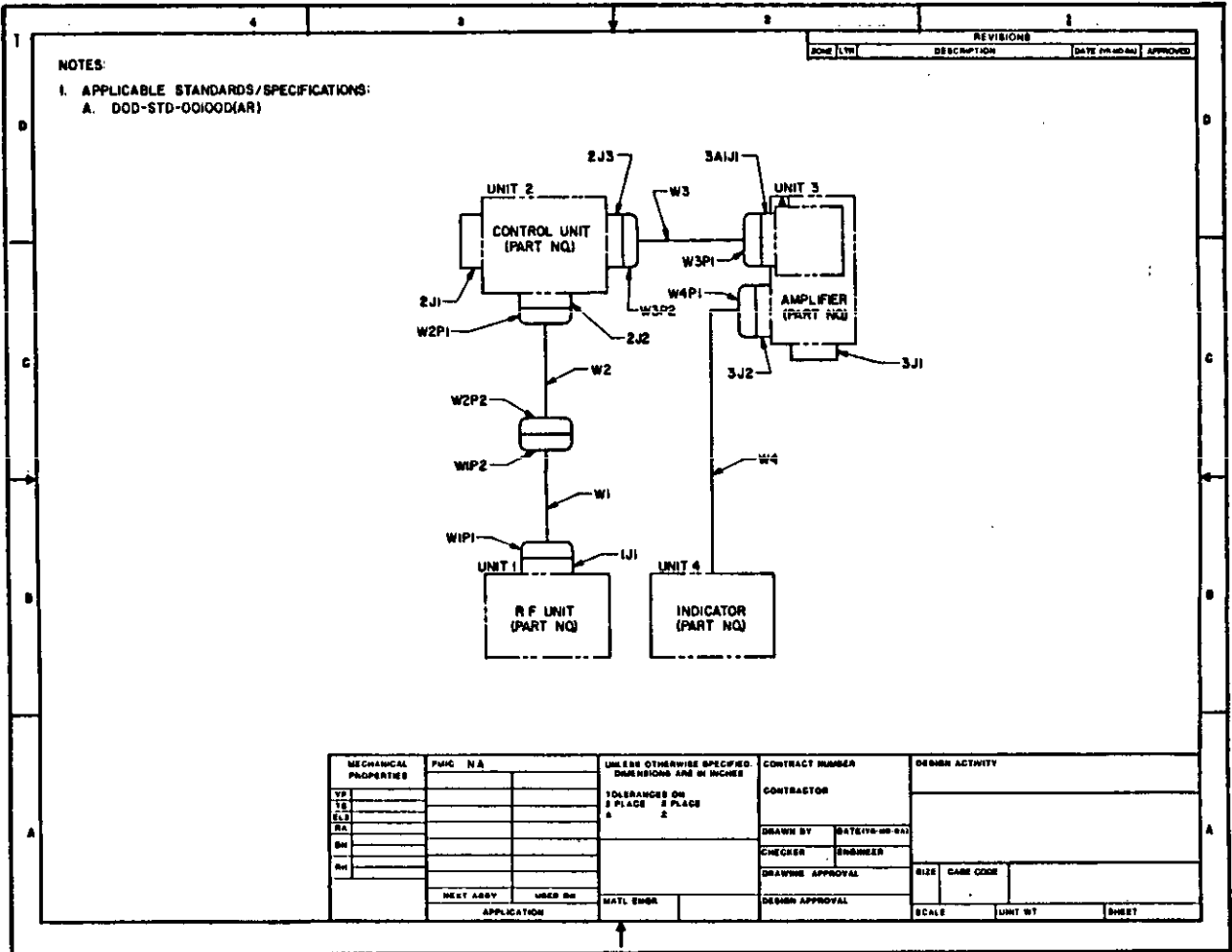

FIGURE 200-23a. Interconnection diagram drawing (cabling type)

This sample drawing is informational only and complete to the degree necessary to illustrate a type of drawing. Actual format and drawing shall conform to the textual requirements set forth in this standard.

DOD-STD-00100D(AR)

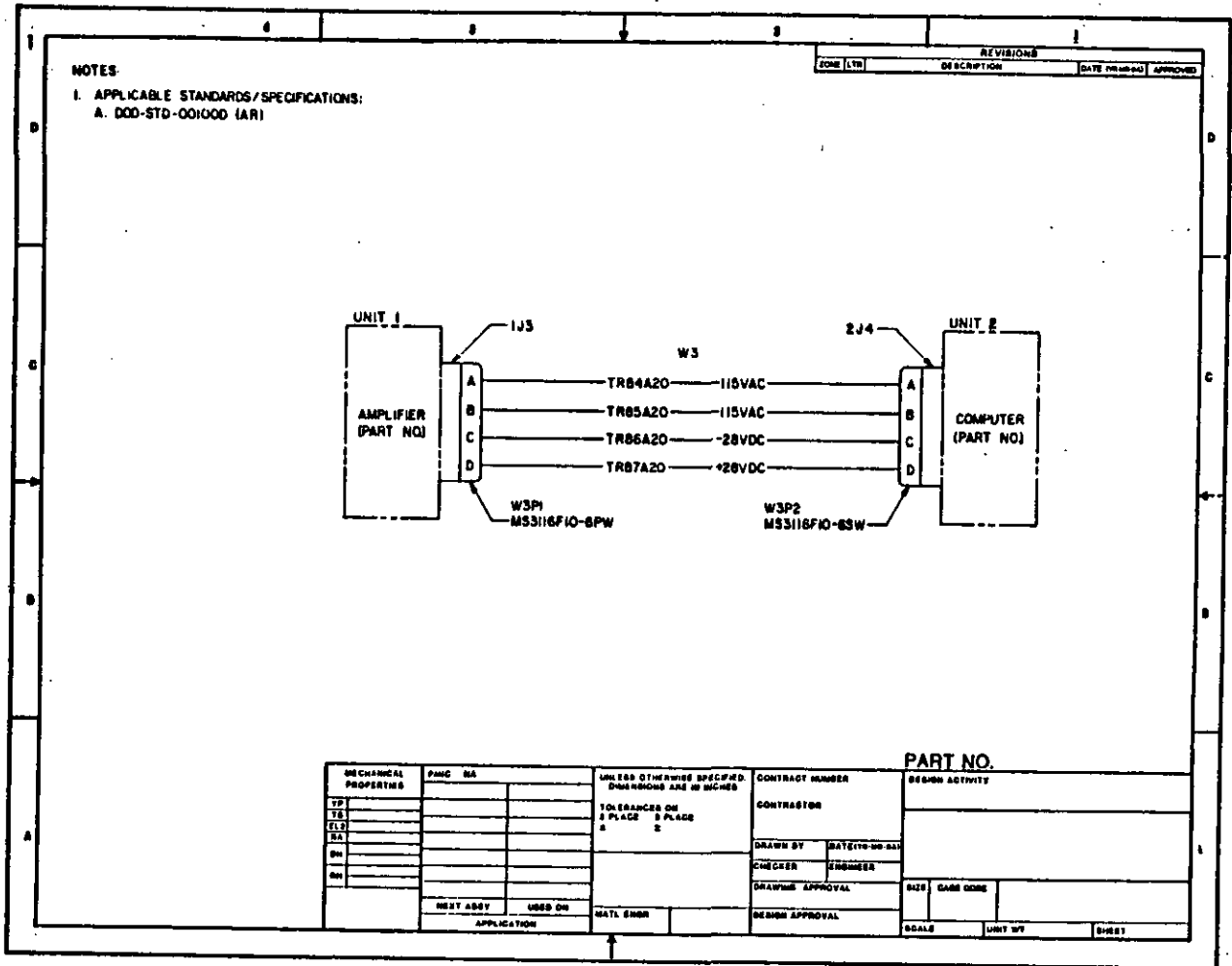

FIGURE 200-23b. Interconnection diagram

This sample drawing is informational only and complete to the degree necessary to illustrate a type of drawing. Actual format and drawing shall conform to the textual requirements set forth in this standard.

DOD-STD-00100D(AR)

201.7.4 Single-line or one-line diagram. A single-line or one-line diagram shows, by means of single lines and graphic symbols, the course of an electric circuit, or system of circuits and the component devices or parts used therein. See FIGURE 200-24.

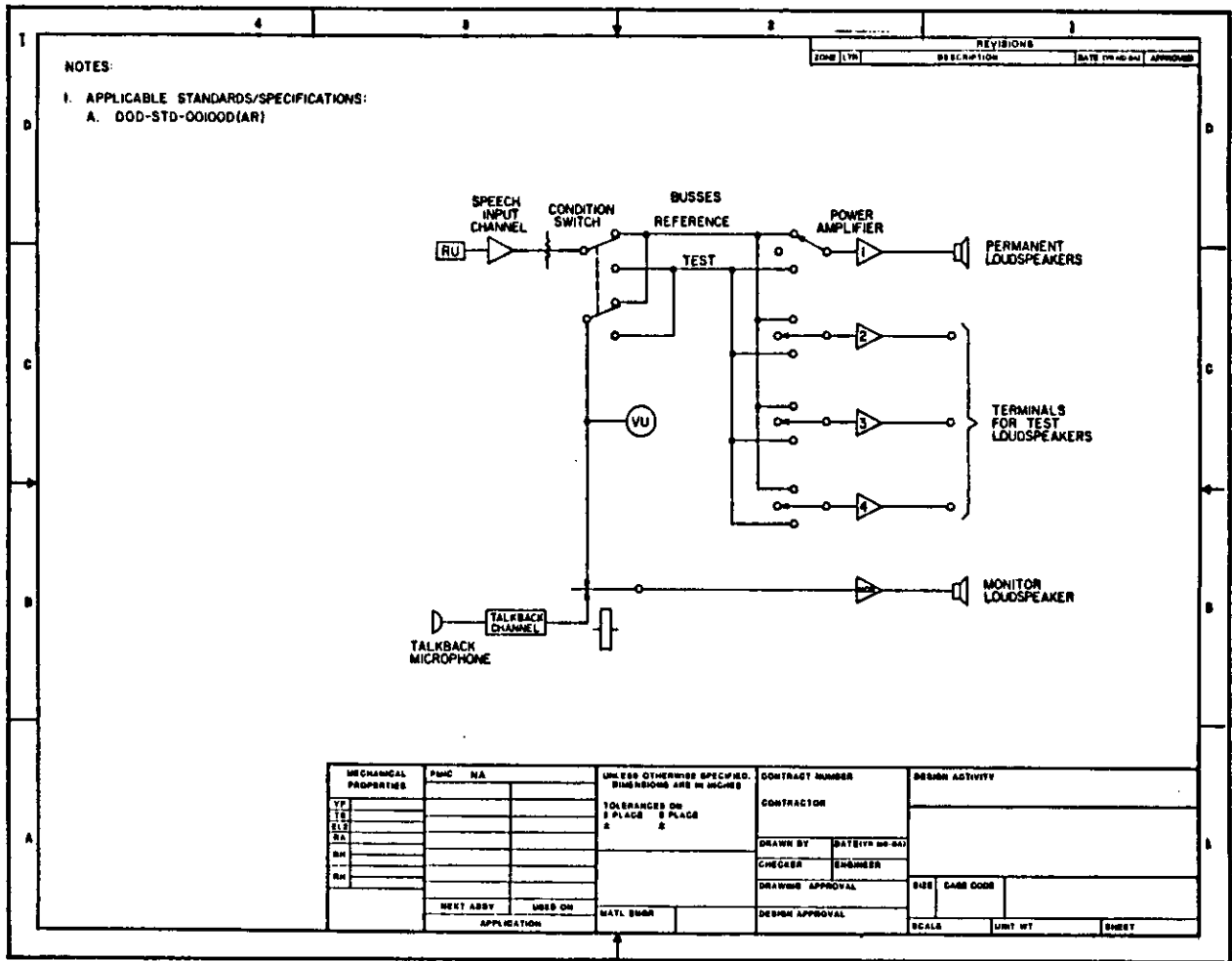

FIGURE 200-24. Single-line diagram drawing

This sample drawing is informational only and complete to the degree necessary to illustrate a type of drawing. Actual format and drawing shall conform to the textual requirements set forth in this standard.

DOD-STD-00100D(AR)

201.7.5 Logic diagram. A logic diagram shows by means of graphic symbols the sequence and function of logic circuitry. See FIGURE 200-25.

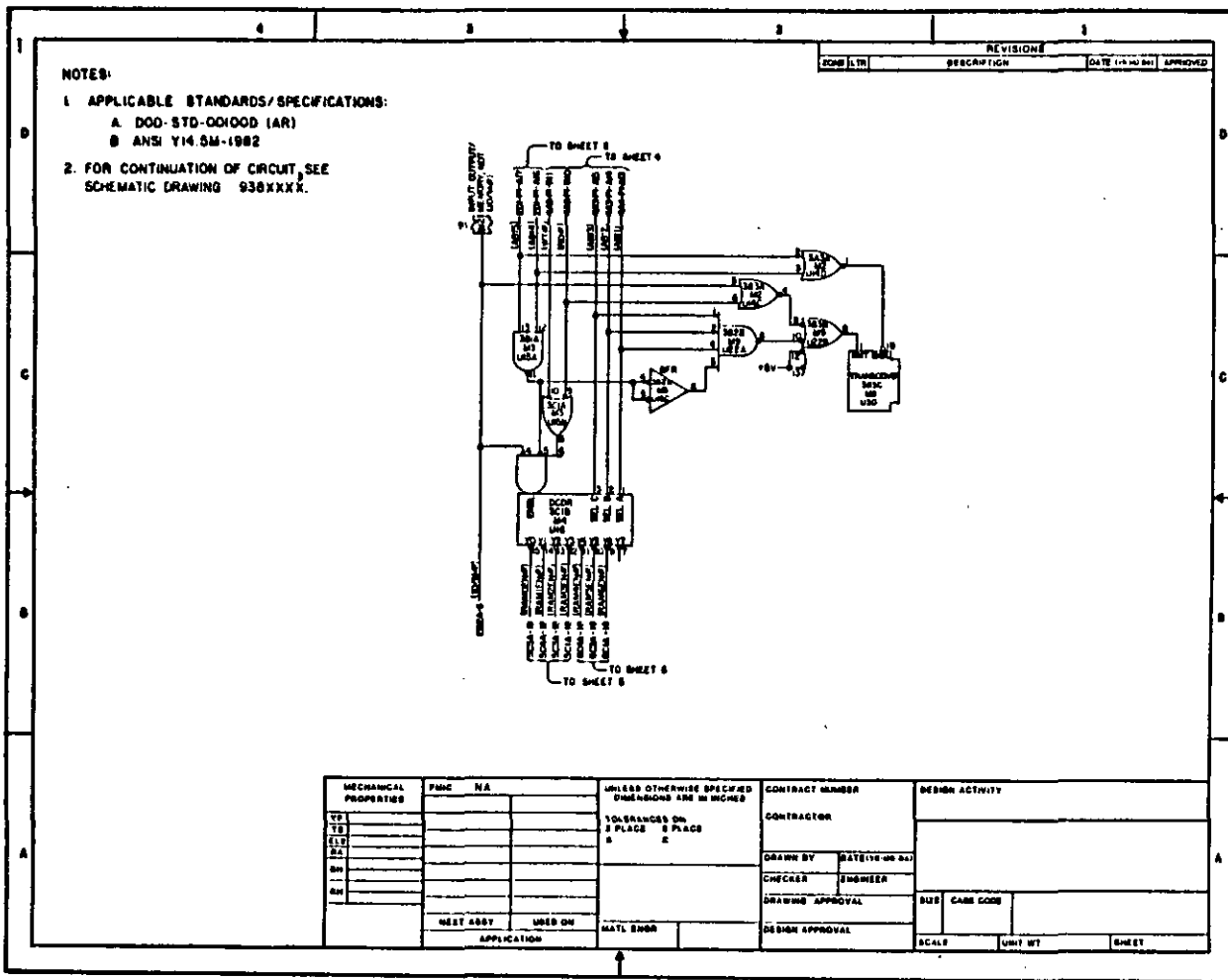

FIGURE 200-25. Logic diagram drawing

This sample drawing is informational only and complete to the degree necessary to illustrate a type of drawing. Actual format and drawing shall conform to the textual requirements set forth in this standard.

DOD-STD-00100D(AR)

201.7.6 Mechanical schematic diagram. A mechanical schematic diagram illustrates the operational sequence or arrangement of a mechanical device(s). A mechanical schematic diagram shall be prepared for each major item or functional assembly comprising a complex arrangement of gears, clutches, linkages, cams, etc., where operating principles cannot readily be derived from a study of assembly drawings. Diagrams shall be shown as part of applicable assembly drawings. Separate diagram drawings shall not be prepared. See FIGURE 200-26.

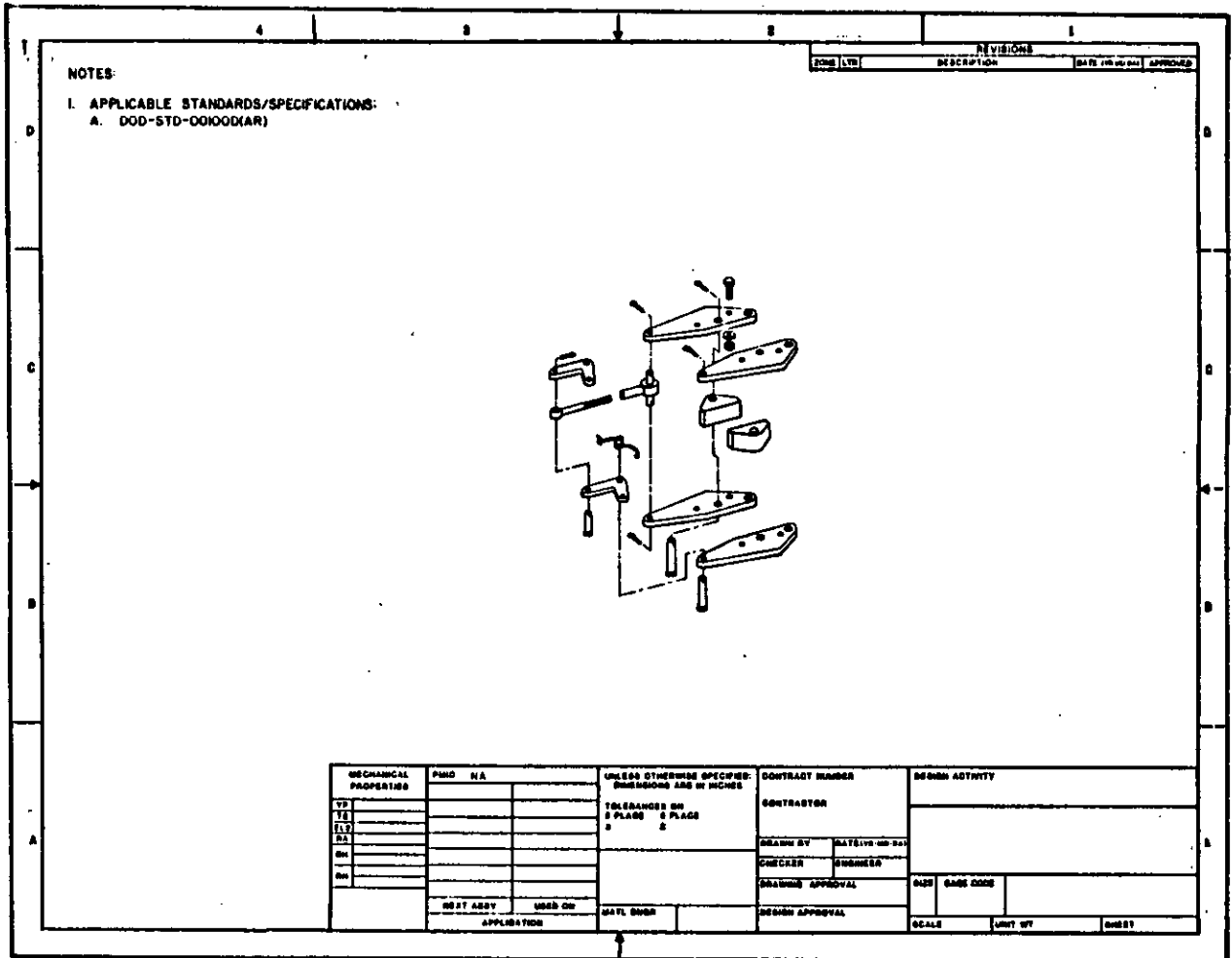

FIGURE 200-26. Mechanical schematic diagram drawing

This sample drawing is informational only and complete to the degree necessary to illustrate a type of drawing. Actual format and drawing shall conform to the textual requirements set forth in this standard.

DOD-STD-00100D(AR)

201.7.7 Piping diagram. A piping (hydraulic, pneumatic, or fluid) diagram depicts the interconnection of components by piping, tubing or hose, and when desired, sequential flow of fluids in the system. See FIGURE 200-27.

201.7.7.1 Requirements. Sufficient detail shall be shown to either explain (a) the arrangement of the piping, valves, etc., or (b) operational sequence. Symbolic line representation may be used to distinguish functions of various parts. When the objective is to show arrangement, the following characteristics may be shown: routing of fluids, physical locations and arrangement of components, pipe diameters, types and sizes of fittings, flow, pressure, volume, etc.

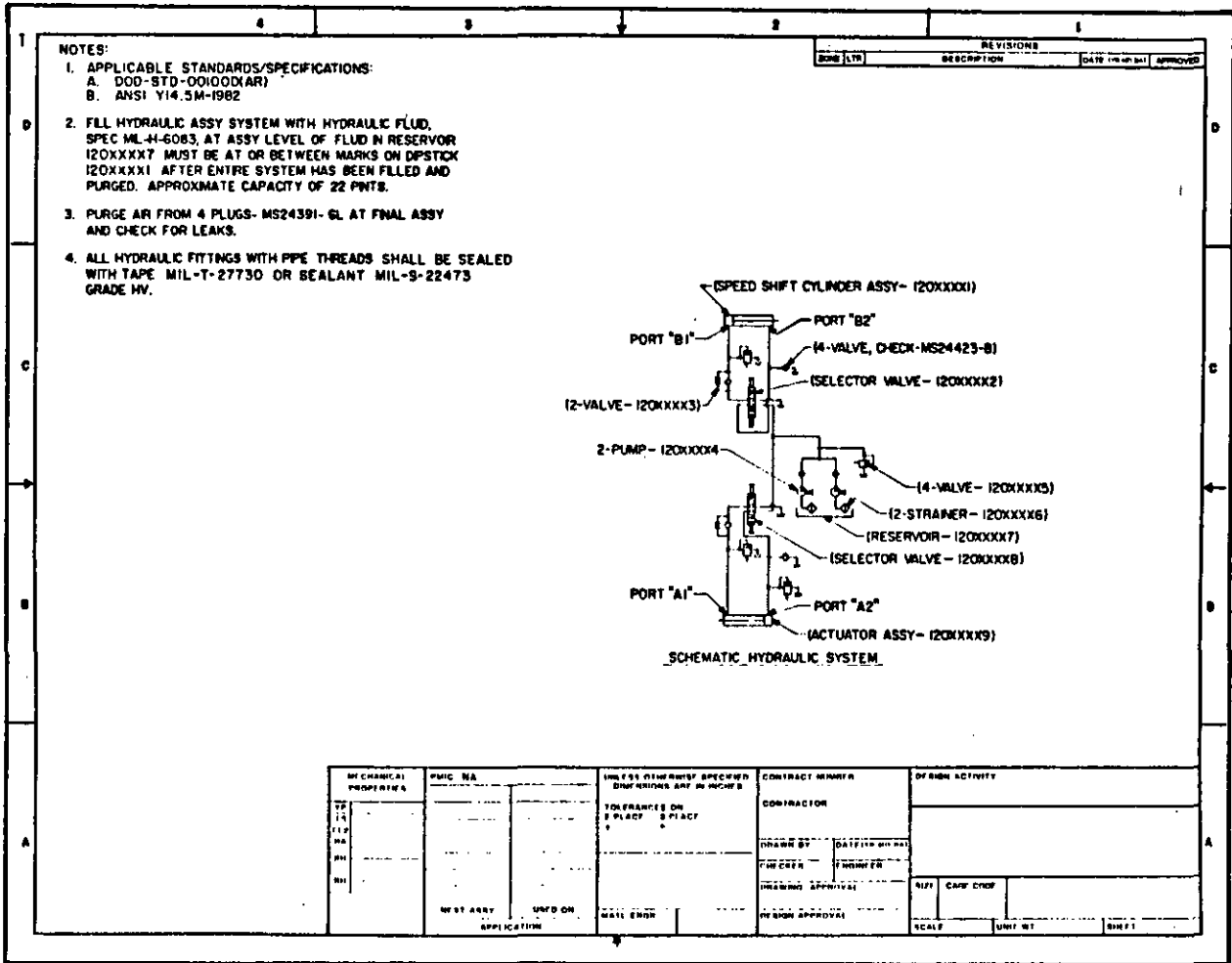

FIGURE 200-27. Piping diagram drawing

This sample drawing is informational only and complete to the degree necessary to illustrate a type of drawing. Actual format and drawing shall conform to the textual requirements set forth in this standard.

DOD-STD-00100D(AR)

201.8 Construction drawing. A construction drawing delineates the design of buildings, structures, or related construction, ashore or afloat, individually or in groups and is normally associated with the architectural-construction-civil engineering operations. Construction drawings establish all the interrelated elements of an architectural-civil engineering design, including pertinent services, equipment, utilities and other engineering details. Maps, except those accompanying or used in conjunction with construction drawings, sketches, presentation drawings, perspectives, and renderings are not considered to be construction drawings.

201.8.1 Erection drawing. An erection drawing shows procedures and operation sequence for erection or assembly of individual items or assemblies of items.

201.8.1.1 Requirements. An erection drawing shall show the location of each part in the structure, identification markings, types of fastenings required, approximate weight or heavy structural members, controlling dimensions, and any other information which will contribute to erection of the structure.

201.8.2 Plan drawing. A plan drawing depicts a horizontal projection of a structure, showing the layout of the foundation, floor, deck, roof or utility system. See FIGURE 200-28.

201.8.2.1 Requirements. As applicable, a plan drawing shall show shapes, sizes and materials of the foundation, its relation to the superstructure and its elevation with reference to fixed datum plane, location of walls, partitions, bulkheads, stanchions, companionways, openings, columns, stairs, shapes and sizes of roofs, parapet walls, drainage, skylights, ventilators, etc. A plan drawing shall specify materials of construction and shall show the arrangement of structural framing. As applicable, the location of equipment or furniture may be indicated. A plan drawing for services may also depict individual layouts for heating, plumbing, air conditioning, electrical or other utility systems.

DOD-STD-00100D(AR)

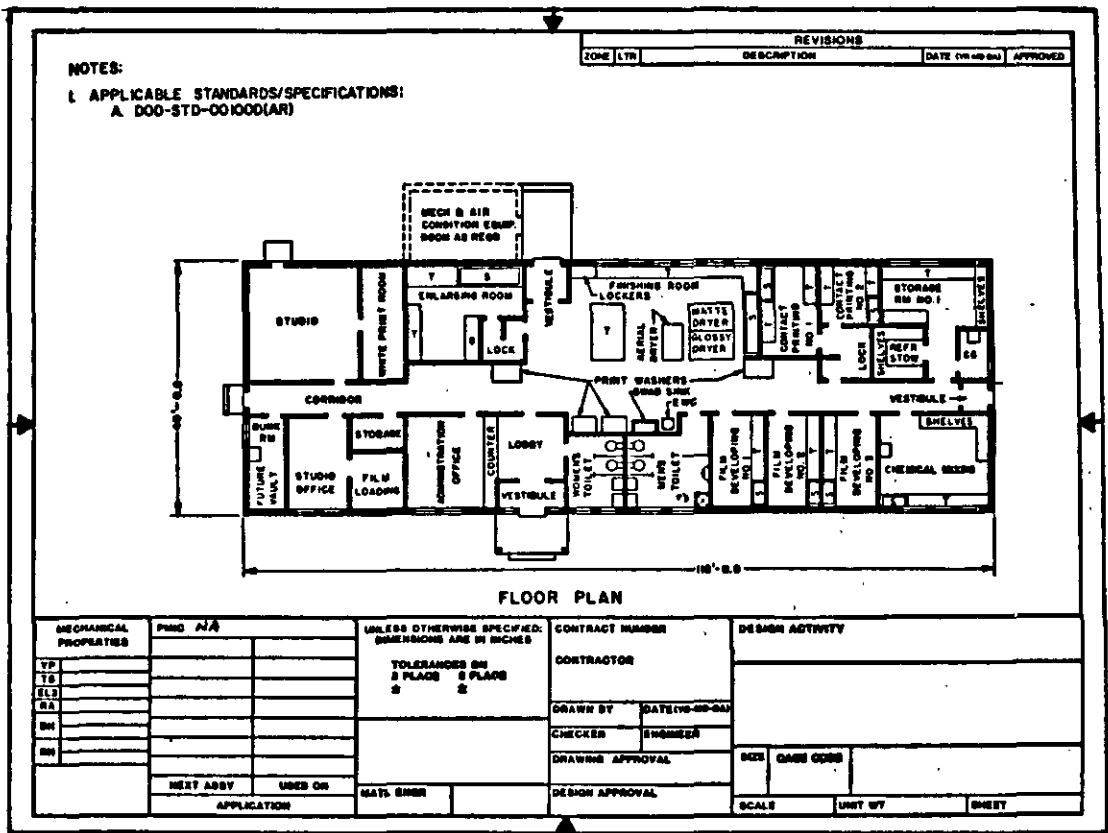

FIGURE 200-28. Plan drawing

This sample drawing is informational only and complete to the degree necessary to illustrate a type of drawing. Actual format and drawing shall conform to the textual requirements set forth in this standard.

DOD-STD-00100D(AR)

201.8.3 Plot (plat) plan drawing. A plot (plat) plan drawing depicts areas on which structures are clearly indicated with detailed information regarding their relationship to other structures, existing and proposed utilities, topography, boundary lines, roads, walks, fences, etc.

201.8.3.1 Requirements. A plot (plat) plan drawing shall show as necessary, the property lines and locations, contours and profiles, shrubbery, existing and new utilities, sewer and waterlines, building lines, location of structures to be constructed, existing structures, approaches, finished grades and other pertinent data.

201.8.4 Vicinity plan or site drawing. A vicinity plan or site drawing (or vicinity map used with construction drawings) delineates the relationship of a site to features of the surrounding area, such as town, bodies of water, railroads, highways, etc.

201.9 Special purpose drawings. Special purpose drawings are other than end-product* drawings used to supplement end-product* requirements. These kinds of engineering drawings may be required for management control, logistic purposes, configuration management, manufacturing aids, and other functions unique to a Government Design Activity. Drawings of a general nature that describe unique data, processes, methods, heat treatment, protective finishes, special painting, etc., shall be prepared as a general requirements drawing in either book-form or larger format.

201.9.1 Book-form drawing. Book-form drawing basic format shall be as illustrated in FIGURE 200-29a. Book-form continuation sheets shall be as illustrated in FIGURE 200-29b. A book-form drawing is an assemblage of related data disclosing by means of pictorial delineations, text or technical tabulations, or combinations thereof, the engineering requirements of an item, a family of items, or a system. A book-form drawing is used for special purpose application in which it is expeditious to provide a document consisting of numerous small sheets, suitable for binding into book form. Book-form drawings shall not be formatted as a specification. Specifications shall be prepared in accordance with MIL-STD-490 or MIL-STD-961, as applicable. See FIGURES 200-29a through 200-29f.

201.9.1.1 Requirements. Book-form drawings shall be "A" size only. Sheet 1 shall contain a revision status sheet. Remaining (continuation) sheets shall not include a revision block (upper right); however, they shall contain a revision level block. Book-form drawings will be prepared only with prior approval of the Government Design Activity. Specifications will not be approved as book-form drawings.

DOD-STD-00100D(AR)

APPLICATION		REVISIONS										
NEXT ASST	USED ON	LTR	DESCRIPTION							DATE (YY-MM-DD)	APPROVED	

REV																						
SHEET																						
REV																						
SHEET																						
REV STATUS	REV	B	-	A	-	-	-	B	B	B												
OF SHEETS	SHEET	1	2	3	4	5	6	7	8	9												

PART NO.												
PIANO A UNLESS OTHERWISE SPECIFIED: DIMENSIONS ARE IN INCHES TOLERANCES ON 3 PLACE 3 PLACE 2 2			CONTRACT NUMBER				DESIGN ACTIVITY					
			CONTRACTOR									
			DRAWN BY		DATE (YY-MM-DD)							
			CHECKER		ENGINEER							
			DRAWING APPROVAL									
MATERIAL ENGR			DESIGN APPROVAL				SIZE	CAGE CODE				
							SCALE	UNIT WT	SHEET			

FIGURE 200-29a. Book-form drawing (Title sheet)

This sample drawing is informational only and complete to the degree necessary to illustrate a type of drawing. Actual format and drawing shall conform to the textual requirements set forth in this standard.

DOD-STD-00100D(AR)

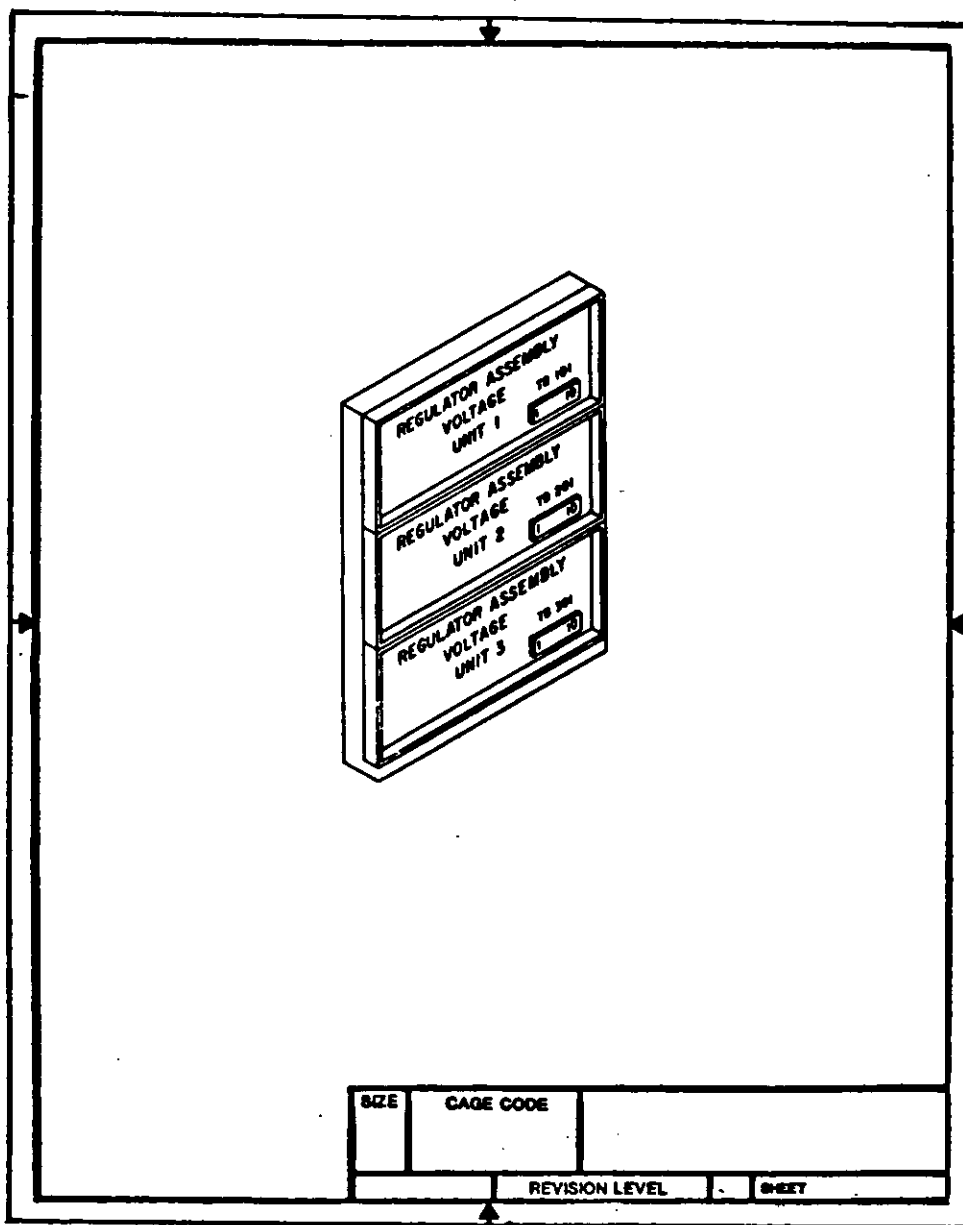

FIGURE 200-29b. Book-form drawing (Continuation sheet)

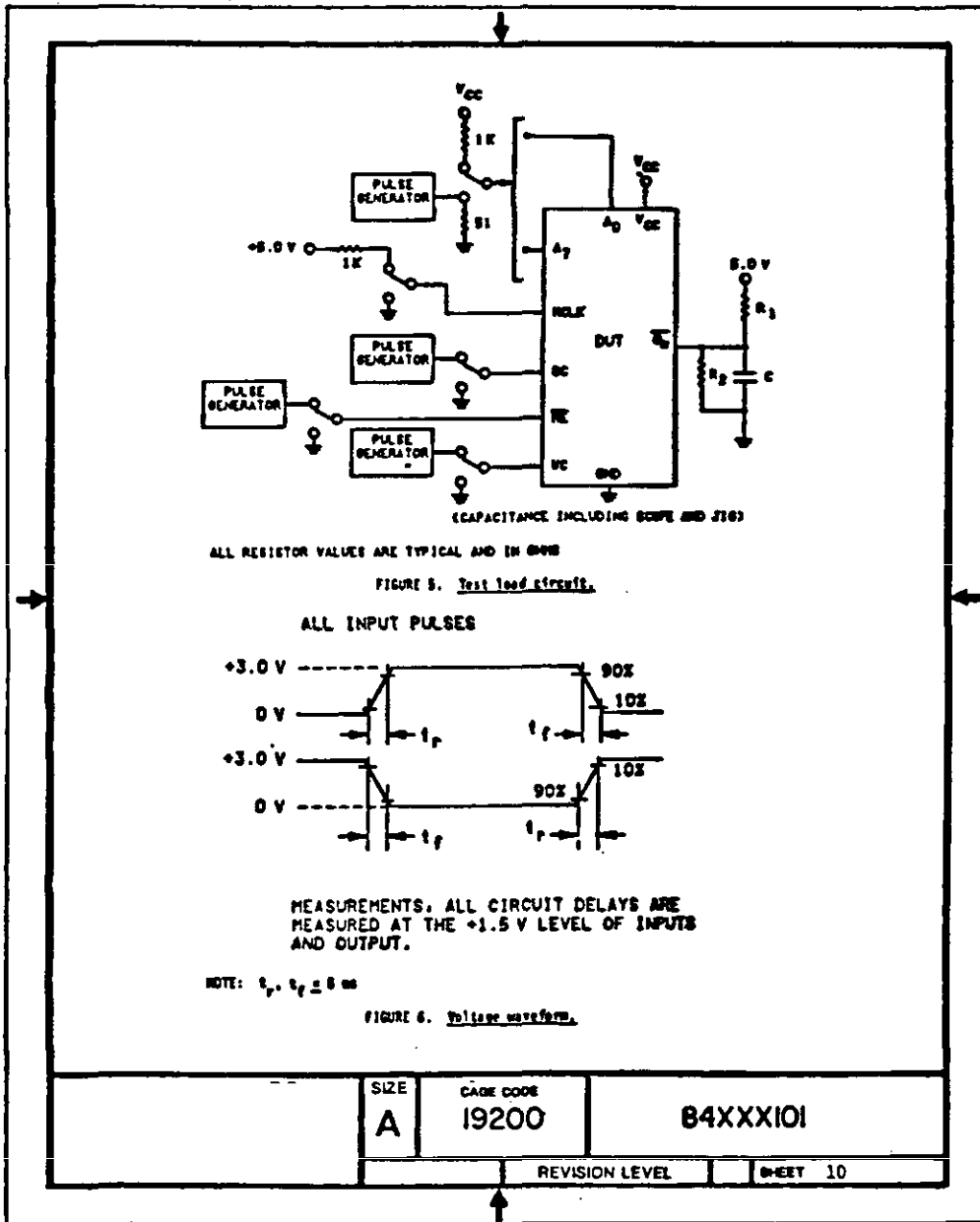

FIGURE 200-29c. Book-form drawing (Continuation sheet)

DOD-STD-00100D(AR)

LIST OF UNITS			
<u>UNIT DESIGNATION</u>	<u>TITLE</u>	<u>DWG NO.</u>	<u>CABLE SUMMARY SHEET NO.</u>
1	REGULATOR	000277	10
2	REGULATOR	000278	10
3	REGULATOR	000279	11
4	POWER SUPPLY	000280	11
5	POWER SUPPLY	000442	11
6	POWER DISTRIBUTION	000711	12

SIZE	CAGE CODE	
	REVISION LEVEL	SHEET

FIGURE 200-29d. Book-form drawing (List of Units)

DOD-STD-00100D(AR)

CABLE NO. 00		CABLE NO.	
CABLE TYPE GROUP		UNIT 1	UNIT 2
ACTIVE WIRE 1		UNIT 1	UNIT 2
UNIT 1 WIRE NO.	WIRE NO.	UNIT 2 WIRE NO.	FUNCTION
101-1	101	101	TROUBLE
101-2	102	102	WIRE
101-3	103	103	WIRE
101-4	104	104	WIRE
101-5	105	105	WIRE
101-6	106	106	WIRE
101-7	107	107	WIRE
101-8	108	108	WIRE
101-9	109	109	WIRE
101-10	110	110	WIRE
101-11	111	111	WIRE
101-12	112	112	WIRE
101-13	113	113	WIRE
101-14	114	114	WIRE
101-15	115	115	WIRE
101-16	116	116	WIRE
101-17	117	117	WIRE
101-18	118	118	WIRE
101-19	119	119	WIRE
101-20	120	120	WIRE
101-21	121	121	WIRE
101-22	122	122	WIRE
101-23	123	123	WIRE
101-24	124	124	WIRE
101-25	125	125	WIRE
101-26	126	126	WIRE
101-27	127	127	WIRE
101-28	128	128	WIRE
101-29	129	129	WIRE
101-30	130	130	WIRE
101-31	131	131	WIRE
101-32	132	132	WIRE
101-33	133	133	WIRE
101-34	134	134	WIRE
101-35	135	135	WIRE
101-36	136	136	WIRE
101-37	137	137	WIRE
101-38	138	138	WIRE
101-39	139	139	WIRE
101-40	140	140	WIRE
101-41	141	141	WIRE
101-42	142	142	WIRE
101-43	143	143	WIRE
101-44	144	144	WIRE
101-45	145	145	WIRE
101-46	146	146	WIRE
101-47	147	147	WIRE
101-48	148	148	WIRE
101-49	149	149	WIRE
101-50	150	150	WIRE
101-51	151	151	WIRE
101-52	152	152	WIRE
101-53	153	153	WIRE
101-54	154	154	WIRE
101-55	155	155	WIRE
101-56	156	156	WIRE
101-57	157	157	WIRE
101-58	158	158	WIRE
101-59	159	159	WIRE
101-60	160	160	WIRE
101-61	161	161	WIRE
101-62	162	162	WIRE
101-63	163	163	WIRE
101-64	164	164	WIRE
101-65	165	165	WIRE
101-66	166	166	WIRE
101-67	167	167	WIRE
101-68	168	168	WIRE
101-69	169	169	WIRE
101-70	170	170	WIRE
101-71	171	171	WIRE
101-72	172	172	WIRE
101-73	173	173	WIRE
101-74	174	174	WIRE
101-75	175	175	WIRE
101-76	176	176	WIRE
101-77	177	177	WIRE
101-78	178	178	WIRE
101-79	179	179	WIRE
101-80	180	180	WIRE
101-81	181	181	WIRE
101-82	182	182	WIRE
101-83	183	183	WIRE
101-84	184	184	WIRE
101-85	185	185	WIRE
101-86	186	186	WIRE
101-87	187	187	WIRE
101-88	188	188	WIRE
101-89	189	189	WIRE
101-90	190	190	WIRE
101-91	191	191	WIRE
101-92	192	192	WIRE
101-93	193	193	WIRE
101-94	194	194	WIRE
101-95	195	195	WIRE
101-96	196	196	WIRE
101-97	197	197	WIRE
101-98	198	198	WIRE
101-99	199	199	WIRE
101-100	200	200	WIRE

SIZE	CAGE CODE	
REVISION LEVEL		SHEET

FIGURE 200-29e. Book-form drawing (Cable wiring sheet)

DOD-STD-00100D(AR)

WIRE NO	BODY	COLOR		APPROX LENGTH REQUIRED		TOTAL INCHES	REFERENCE
		FIRST TRACE	SECOND TRACE	FROM	TO		
1	BLK			J181-1	T8181-3		ML-8-1427 TYPE C-B
2	"			J182-6	T8181-3		"
3	"			J182-2	T182-2		"
4	BLK			T8182-9	T8182-2		ML-8-1427 TYPE C-B
11	BRN			XV182-2	XV181-2	60	ML-8-1427 TYPE C-B
12	"			XV182-7	XV182-2		"
13	"			XV182-2	T181-2		"
14	BRN			XV182-2	XV182-2		ML-8-1427 TYPE C-B
16	BRN			T8182-3	T8181-11	27	ML-8-1427 TYPE C-B
17	"			T8181-11	T8181-1		"
18	"			T8182-1	C182-A		"
21	RED			T8182-4	C182-B		ML-8-1427 TYPE C-B
23	BRN			T8181-10	XV181-4	60	ML-8-1427 TYPE C-B
27	"			T8182-4	XV182-4		"
27	BRN			XV182-4	XV182-9		ML-8-1427 TYPE C-B
31	TEL			T8182-9	XV182-9	20	ML-8-1427 TYPE C-B
32	TEL			T8181-4	XV181-9	20	ML-8-1427 TYPE C-B
33	BRN			J181-2	T8181-1		ML-8-1427 TYPE C-B
33	"			J182-C	XV182-9		"
33	"			J182-9	T8181-13		"
33	"			T8182-6	XV182-9		"
33	"			T8182-14	T8181-13		"
41	BRN			T8181-4	XV181-4		ML-8-1427 TYPE C-B
46	BLU			T8182-4	XV182-3	60	ML-8-1427 TYPE C-B
47	BLU			T8181-14	XV181-4		ML-8-1427 TYPE C-B
52	GY			J184-B	T181-B	27	ML-8-1427 TYPE C-B
53	"			J184-A	J182-F		"
54	GY			J182-A	T181-A		ML-8-1427 TYPE C-B
57	WHT			J182-B	T8182-13	60	ML-8-1427 TYPE C-B
60	WHT	BLK	BRN	XV182-6	T181-5	12	ML-8-1427 TYPE C-B
61	WHT	BLK	BRN	XV182-2	V181-6		ML-8-1427 TYPE C-B
64	WHT	BLK	RED	T8182-3	C182-C	20	ML-8-1427 TYPE C-B
65	"			T181-6	T182-4		"
66	WHT	BLK	RED	T181-6	C182-C		ML-8-1427 TYPE C-B
69	WHT	BLK	BRN	T8182-3	XV182-3	23	ML-8-1427 TYPE C-B
70	WHT	BLK	BRN	T8182-11	XV182-3		ML-8-1427 TYPE C-B
72	WHT	BLK	BRN	XV182-3	T182-3	41	ML-8-1427 TYPE C-B
74	WHT	BLK	BRN	XV182-3	T182-3		ML-8-1427 TYPE C-B
77	WHT	BLK	BLU	XV182-4	T181-3	14	ML-8-1427 TYPE C-B
78	WHT	BLK	BLU	XV182-6	T181-4		ML-8-1427 TYPE C-B
81	WHT	BRN	RED	J182-1	T182-1	20	ML-8-1427 TYPE C-B

SIZE	CAGE CODE	
REVISION LEVEL		SHEET

FIGURE 200-29f. Book-form drawing (Wiring list)

DOD-STD-00100D(AR)

201.9.2 Wiring list. A wiring list consists of tabulated data as a substitute for data indicated and shown on a wiring diagram. These data, columns, represents wire designators, terminations, whether to an individual or common connector assembly, or just wires or circuits spliced together. A wiring diagram should accompany it in order to put the "Tees" (or splices) in the proper place and perspective if the item is more than a cable assembly. A wire list may be in computer printout form if authorized by the Government Design Activity. A wiring list is a form of interconnection or connection diagram (see paragraphs 201.7.2, 201.7.3, and FIGURE 200-29f). Book-form drawing formats lend themselves to the delineation of wiring lists.

201.9.2.1 Requirements. The principal sections of a wiring list shall be as follows, as appropriate.

- a. Title sheet and revision status of sheets tabulation.
- b. Referenced documents.
- c. Illustrations. Figures necessary to supplement the tabulation shall be provided.
- d. Summaries of wiring or cabling information by units.
- e. Wiring connection information.

201.9.3 Numerical control drawing. A numerical control (NC) drawing depicts complete physical and functional engineering and product requirements of an item to facilitate production by automated control means. See FIGURE 200-30.

DOD-STD-00100D(AR)

201.9.3.1 Requirements. A numerical control (NC) drawing shall convey, directly or by reference, all engineering requirements for the part(s) to be manufactured either partially or totally with numerical control equipment. For items capable of production by NC or conventional methods the information shall be sufficient to permit manufacture by either method. The numerical control drawing shall integrate any special dimensioning requirements of numerical control machine planning and operation without compromising design requirements. The decimal system shall be used for location of features such as machined surfaces, holes, slots, etc. Features are normally defined in a rectangular coordinate system. Axis on the drawing shall be considered as intersecting at an origin and should be common with the datum of the part view. The part view should preferably be drawn in the first quadrant (see ANSI Y14.3) so that positive values will result when the programmer prepares the tape. Drawing must present required information to facilitate preparation of the control media in the most economical form and to optimize use of existing basic dimensioning practices.

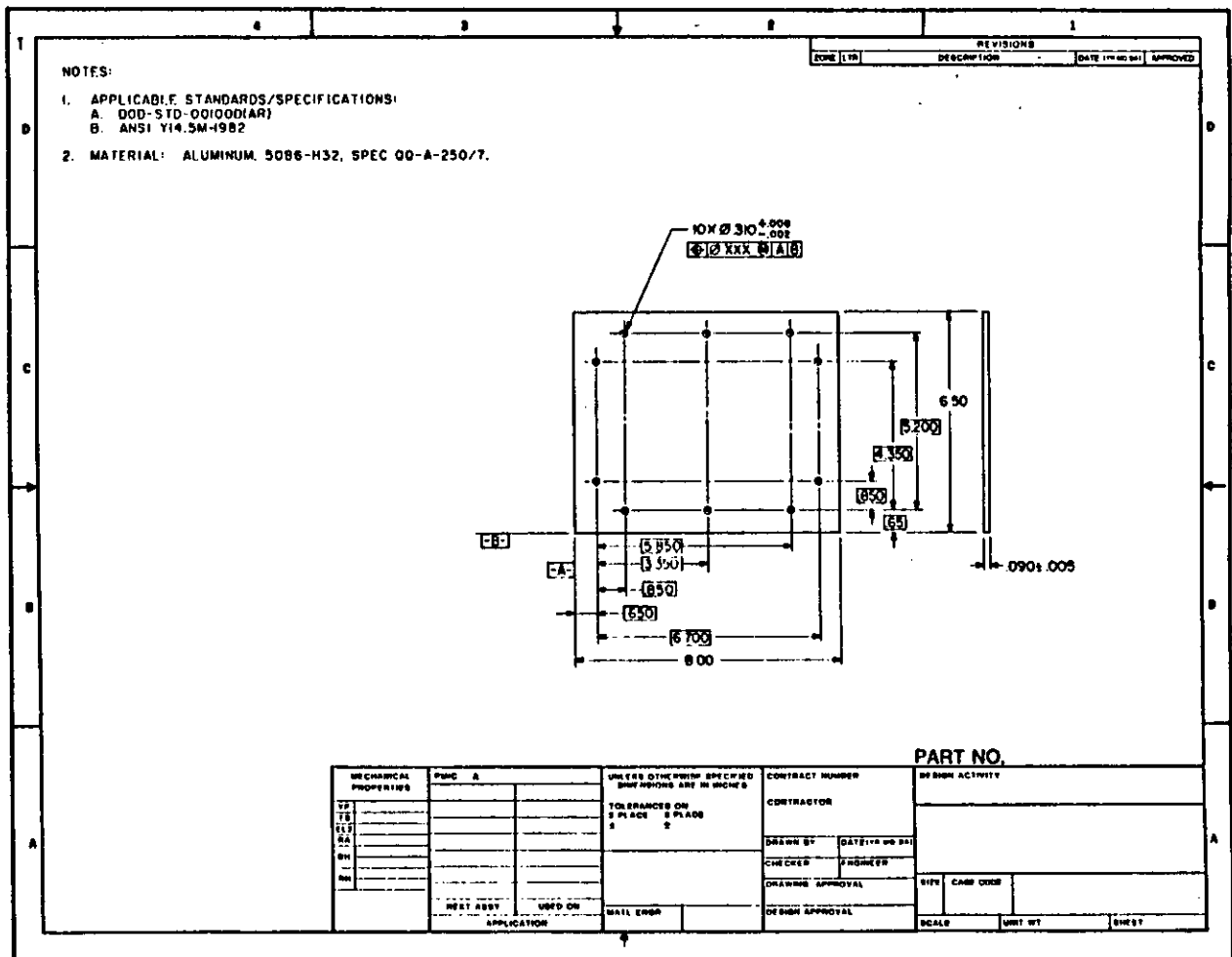

FIGURE 200-30. Numerical control drawing

This sample drawing is informational only and complete to the degree necessary to illustrate a type of drawing. Actual format and drawing shall conform to the textual requirements set forth in this standard.

DOD-STD-00100D(AR)

201.9.4 Optical elements and optical systems drawings. Definitions and requirements for drawings pertaining to optical elements and optical systems are contained in MIL-STD-34.

201.9.5 Wiring harness drawing. A wiring harness drawing shows the path of a group of wires laced together in a specified configuration, so formed to simplify installation. Wiring harness drawings show a harness tree; a trunk with branch circuits laced or taped together and terminated in connectors (or sometimes in bare or tinned wire ends). The total configuration is laid out in accordance with its installation in a box or assembly. See FIGURE 200-31.

201.9.5.1 Requirements. The drawing shall show all dimensions necessary to define the harness form and termination points; or a grid system, or vertical and horizontal graphic scales may be provided, in lieu of dimensions, for use in ascertaining the required dimensional data or undimensioned full scale drawings may be used. The drawing shall also include a wire data tabulation of wire numbers or color codes, circuit reference designations, lengths, material specifications, and other data, as necessary. Included in note form should be instructions, or references thereto, for the preparation of the harness, associated schematic diagram, and the wiring diagram.

a. The overall trunk length and various branch lengths shall be depicted. The part number marker and circuit number identifiers shall be shown and called out. Applicable documentation, standards, specifications and drawings required for item fabrication shall be on the drawing.

b. A wiring diagram following the pictorial paths shall be on the drawing along with circuit identifying numbers or the color code in accordance with MIL-STD-681 and wire size indicators.

c. All connectors and parts (as applicable) shall be called out on the pictorial adjacent to the connector, and the termination shall be noted in front of it. All materials for fabrication shall be specified on the applicable drawing.

d. The harness shall be depicted and dimensioned in the configuration as installed in its assembly. It shall not be depicted flat unless used in that configuration.

DOD-STD-00100D(AR)

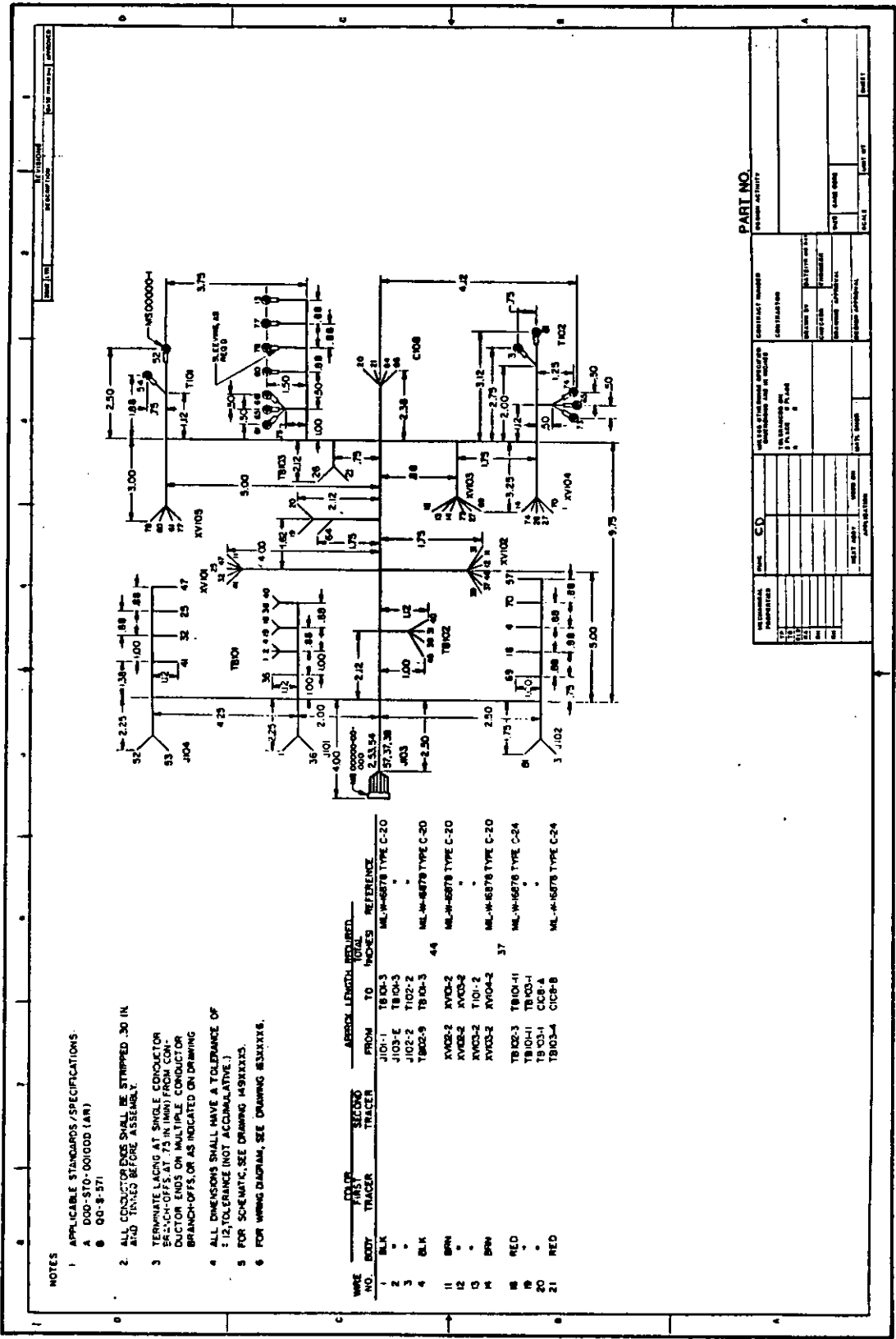

NOTES

- 1 APPLICABLE STANDARDS / SPECIFICATIONS:
A DOD-STD-00100D (AR)
B DD-8-571
- 2 ALL CONDUCTOR ENDS SHALL BE STRIPPED .30 IN AND TRACED BEFORE ASSEMBLY.
- 3 TERMINATE LACING AT SINGLE CONDUCTOR BRANCH-OFFS AT .75 IN (MIN) FROM CONDUCTOR ENDS ON MULTIPLE CONDUCTOR BRANCH-OFFS, OR AS INDICATED ON DRAWING
- 4 ALL DIMENSIONS SHALL HAVE A TOLERANCE OF ± 12 (TOLERANCE NOT ACCUMULATIVE.)
- 5 FOR SCHEMATIC, SEE DRAWING 49XXXXXX.
- 6 FOR WIRING DIAGRAM, SEE DRAWING 53XXXXXX.

WIRE NO.	BODY	TO UP FIRST TRACER	SECOND TRACER	ABSCON LENGTH	TOTAL INCHES	REFERENCE
1	BLK	J101-1	T804-3			ML-W-6678 TYPE C-20
2	BLK	J102-2	T803-2			
3	BLK	J102-2	T802-2			
4	BLK	T802-9	T804-3	44		ML-W-6678 TYPE C-20
11	BRN	XN02-2	XV03-2			ML-W-6678 TYPE C-20
12	BLK	XV02-2	XV03-2			
13	BLK	XV03-2	T101-2			
14	BRN	XV03-2	XV04-2			ML-W-6678 TYPE C-20
15	RED	T802-3	T804-1			
16	RED	T804-1	T803-1			
20	BLK	T803-1	C108-4			
21	RED	T803-4	C108-8			ML-W-6678 TYPE C-24

PART NO.

CONTRACT NUMBER

DATE

BY

CHECKED

APPROVED

REVISIONS

REVISION NO.

DESCRIPTION

FIGURE 200-31. Wiring harness drawing

This sample drawing is informational only and complete to the degree necessary to illustrate a type of drawing. Actual format and drawing shall conform to the textual requirements set forth in this standard.

DOD-STD-00100D(AR)

201.9.6 Cable assembly drawing. A cable assembly drawing depicts power, signal, radio frequency, or audio frequency cables normally used between equipments, units, inter-racks, etc. Cable terminations are normally plugs, sockets, connectors, etc. Cable assembly drawings are similar to the harness assembly drawings previously described, except it is an electrical cable connecting boxes and/or electrical components. The pictorial will show overall length. A wiring diagram is part of the drawing or may be a separate drawing and referenced in the general notes. See FIGURE 200-32.

201.9.6.1 Requirements. A cable assembly drawing shall include the following information as applicable: overall dimensions, including or excluding terminations, tolerances, preparation of ends of cable, wiring or schematic diagram identifying color code of wires and termination terminals, identification bands or marking, special cable and preparation instructions, applicable tests, finish if any, all materials and special assembly instructions. Full or reduced scale undimensioned drawings may be used in lieu of dimensioned drawings.

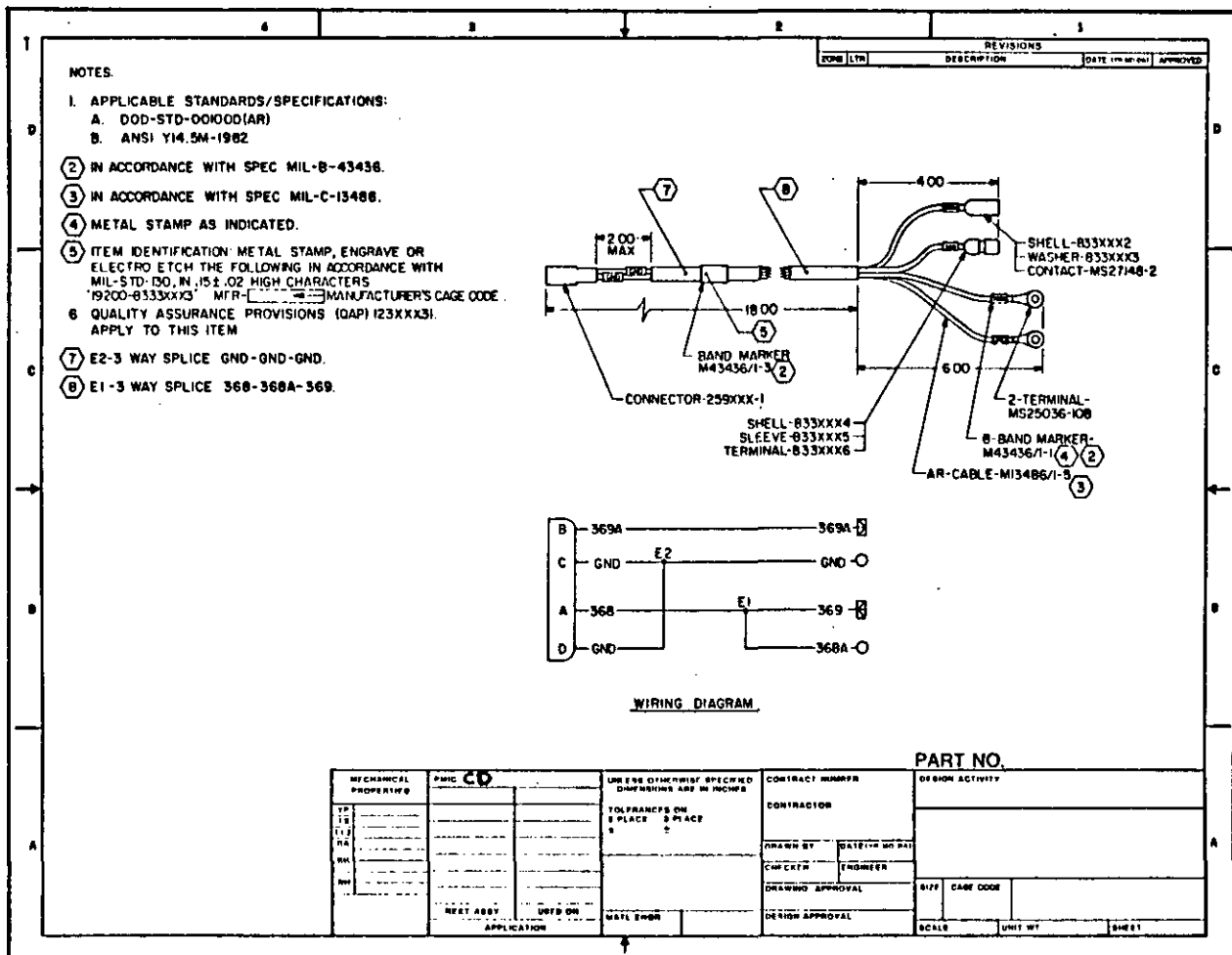

FIGURE 200-32. Cable assembly drawing

This sample drawing is informational only and complete to the degree necessary to illustrate a type of drawing. Actual format and drawing shall conform to the textual requirements set forth in this standard.

DOD-STD-00100D(AR)

201.9.7 Undimensioned drawing. An undimensioned drawing depicts, to a precise scale, on environmental stable material, loft line information, a template, a pattern, panels, reticles, special scales, sheet metal parts, cable assemblies and other components for which dimensioned detail drawings would be impractical.

201.9.7.1 Requirements. Undimensioned drawings shall be supplied for panels, reticles, special scales, and other components for which dimensioned detail drawings would be impractical. Undimensioned master drawings shall be prepared as stable base artwork on dimensionally stable plastic sheets, meeting the applicable requirements for drawing format materials specified in paragraph 104. Drawings shall be of high quality, clearly drawn, typed or scribed with sharp, clean-cut lines to insure a high degree of legible reproducibility. Applied patterns shall be photographically opaque except for desired open areas. See FIGURE 200-33.

NOTE 1: All undimensioned drawings which should not be reproduced for manufacturing purposes except from the master drawing shall contain the following note in 1/4 inch lettering located above the title block:

"ANY REPRODUCTION OF THIS DRAWING, EXCEPT THOSE MADE FROM THE FULL SIZE MASTER ON STABLE BASE MATERIAL, SHALL NOT BE USED FOR MANUFACTURING PURPOSES."

NOTE 2: In addition, the following note shall appear in the general notes:

"FOR MANUFACTURING PURPOSES, THE PRODUCTION MASTER (STABLE BASE ARTWORK) WILL BE FURNISHED, UPON REQUEST, TO THE MANUFACTURER BY THE CONTRACTING OFFICER."

DOD-STD-00100D(AR)

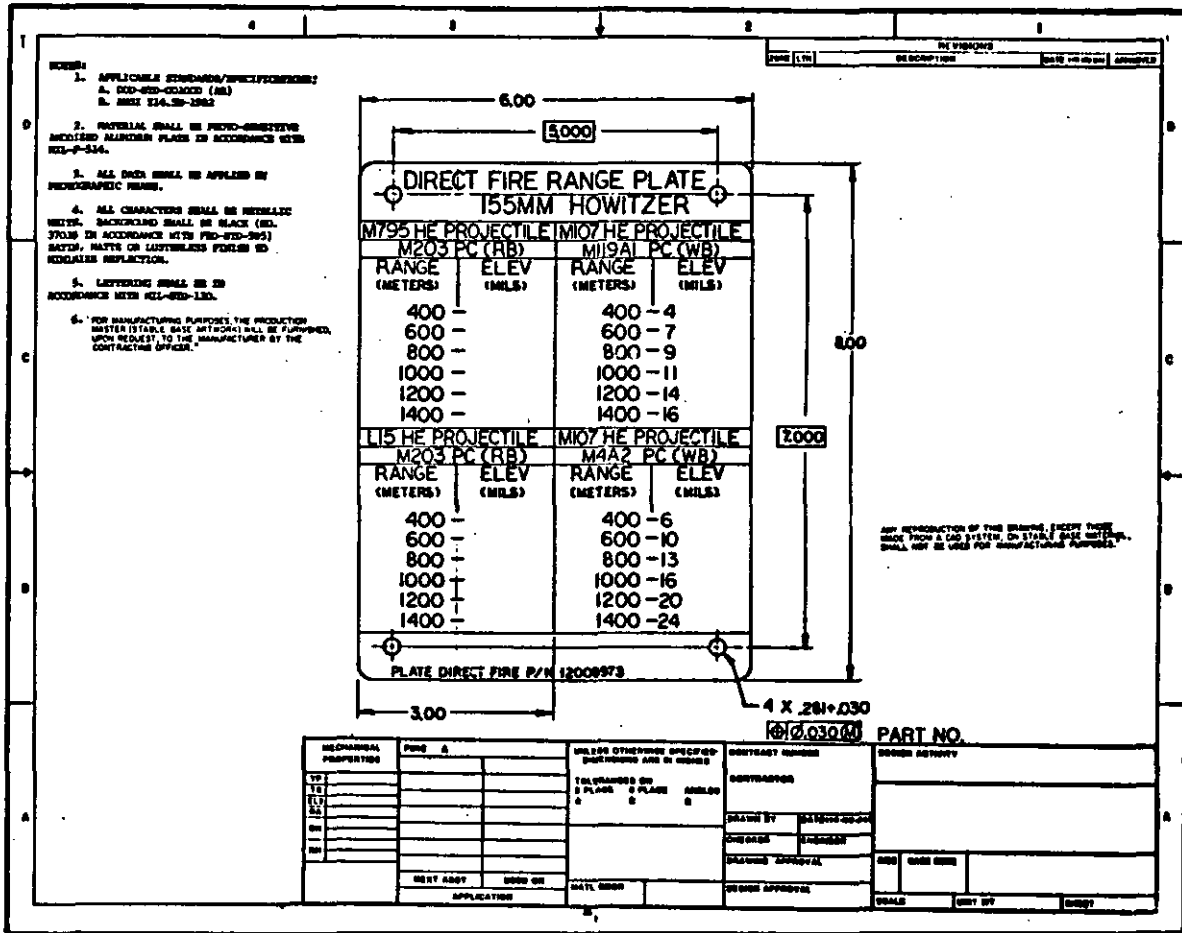

FIGURE 200-33. Undimensioned drawing

This sample drawing is informational only and complete to the degree necessary to illustrate a type of drawing. Actual format and drawing shall conform to the textual requirements set forth in this standard.

DOD-STD-00100D(AR)

201.9.8 Printed wiring master (stable base artwork) pattern drawing. A master drawing is a precise scale pattern which is used to produce the printed circuit within the accuracy specified on drawing. Stable base artwork for production masters shall contains requirements specified in MIL-STD-275. See FIGURE 200-34.

201.9.8.1 Requirements. A printed wiring master pattern drawing is a reproducible copy of the original ink, tape scribed master or computer-generated photoplot prepared on stable base material. The drawing shall have both vertical and horizontal register marks with dimensions and adequate tolerances to control the 1/1 master pattern. The master pattern drawing shall be suitable for making the 1/1 master pattern.

NOTE: Drawings for printed wiring board (patterns) to be fabricated using a production master shall contain the following note in 1/4 inch lettering located above the title block.

"ANY REPRODUCTION OF THIS DRAWING, EXCEPT THOSE MADE FROM THE FULL SIZE MASTER ON STABLE BASE MATERIAL, SHALL NOT BE USED FOR MANUFACTURING PURPOSES."

NOTE: The following note shall appear in the general notes.

"FOR MANUFACTURING PURPOSES, THE PRODUCTION MASTER (STABLE BASE ARTWORK) WILL BE FURNISHED, UPON REQUEST, TO THE MANUFACTURER BY THE CONTRACTING OFFICER."

201.9.8.1.1 Digital form. When the printed wiring master pattern drawing is described in digital form, the description and form shall be in accordance with ANSI/IPC-D-350.

NOTE: The following note shall be shown above the title block.

"ANY REPRODUCTION OF THIS DRAWING, EXCEPT THOSE MADE FROM A CAD SYSTEM, ON STABLE BASE MATERIAL, SHALL NOT BE USED FOR MANUFACTURING PURPOSES."

DOD-STD-00100D(AR)

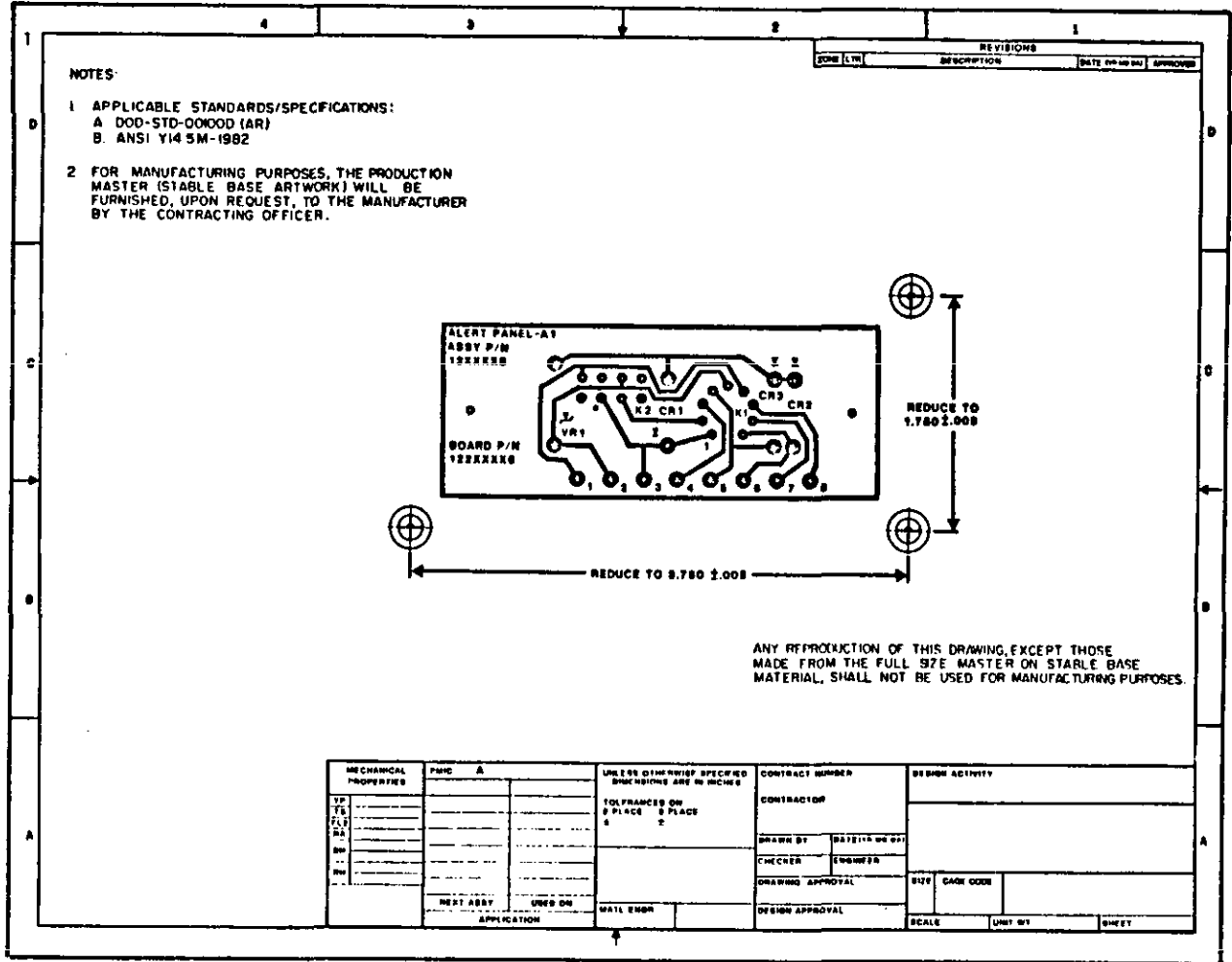

FIGURE 200-34. Printed wiring master pattern drawing

This sample drawing is informational only and complete to the degree necessary to illustrate a type of drawing. Actual format and drawing shall conform to the textual requirements set forth in this standard.

DOD-STD-00100D(AR)

201.9.9 Printed wiring master drawing. A master drawing (board detail) is one that shows the dimensional limits or grid location applicable to any or all parts of a printed wiring board or a printed circuit card including the base. See FIGURE 200-35.

201.9.9.1 Requirements. The master drawing establishes the size and shape of the board, the size and location of all holes therein, and the shape or arrangement of both conductor and non-conductor patterns or elements. Master drawings shall contain the requirements specified in MIL-STD-275. If the printed wiring master drawing is described in digital form, the description and form shall be in accordance with ANSI/IPC-D-350.

DOD-STD-00100D(AR)

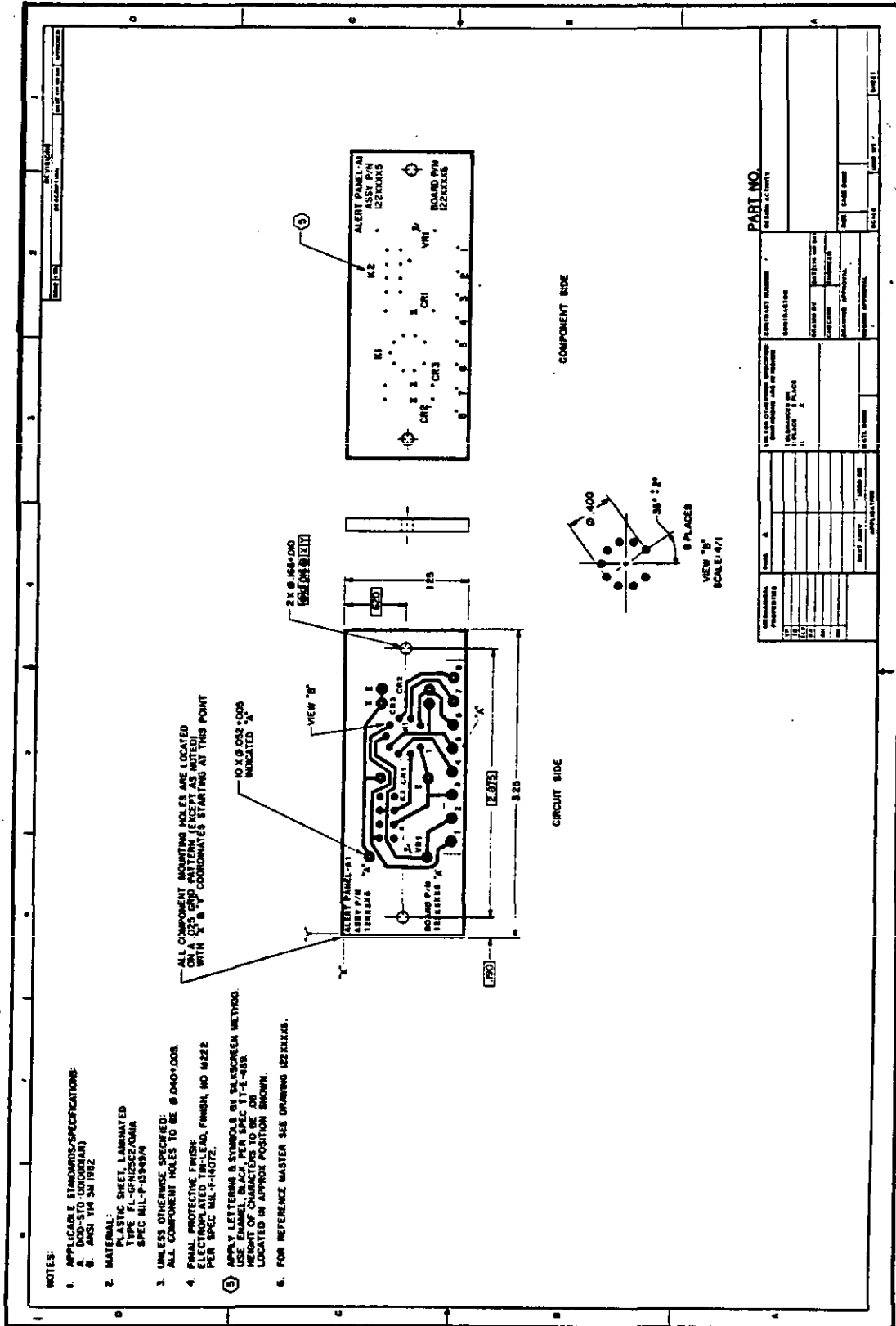

FIGURE 200-35.. Printed wiring master drawing (board detail)

This sample drawing is informational only and complete to the degree necessary to illustrate a type of drawing. Actual format and drawing shall conform to the textual requirements set forth in this standard.

DOD-STD-00100D(AR)

201.9.10 Kit drawing. A kit drawing indicates or depicts a packaged unit, item or group of items, instructions, photographs or drawings such as are used in modification, installation or survival. The items in a kit normally do not in themselves constitute a complete functional assembly. A kit drawing may be a listing of part numbers, a pictorial representation of parts or a combination of both.

a. Modification kit. A modification kit consists of parts, instructions, special tools, templates, etc., which are used to incorporate a change into an item after it has been manufactured.

b. Accessory kit. An accessory kit consists of parts, instructions, special tools, templates, etc., which are used to incorporate additional capabilities into an item; such as heater kits for arctic use or air brake kits to provide a trailer towing capability. The part number and nomenclature of accessory kits will be entered on sheet one of the end item drawing to which they pertain.

c. Software conversion kit. A software conversion kit is a package of drawings which supplement existing drawings and their combined effect is a new end item. Application of conversion kits will change the vehicle designation.

d. Hardware conversion kit. A hardware conversion kit consists of parts, instructions, special tools, templates, etc., which is used to convert an existing hardware item to perform a different function from that which it now performs. For example, a personnel carrier being converted to a bulldozer vehicle or to a recovery vehicle; and an American vehicle being converted to a foreign vehicle performing the same function.

201.9.10.1 Requirements. A kit drawing shall include or reference a list of the entire kit contents, including part numbers and part nomenclature and quantities required.

a. A or B size format only shall be used. When more than one sheet is required, continuation sheet format of the same size (as sheet one) shall be used.

b. An application note shall be included noting the end items involved. Reference paragraph 118.y.

(1) Modification kit.

"THIS KIT IS DESIGNED FOR *Insert Notation From (a),(b) or (c) Below.*
PURPOSES ONLY AND APPLIES TO ALL CARGO TRUCKS, M91X"

(a) FIELD MODIFICATION (DAMWO)

(b) INDUSTRIAL MODIFICATION (IM)

(c) FIELD AND INDUSTRIAL MODIFICATION.

DOD-STD-00100D(AR)

(2) Accessory kit.

"THIS KIT IS APPLICABLE TO ARMORED PERSONNEL CARRIER M22X."

(3) Conversion kit.

"THIS KIT IS DESIGNED TO CONVERT A SEMITRAILER, VAN M5IX TO A SHOP VAN M80X."

c. An installation note shall be as follows. Reference paragraph 118.6x.

"THIS KIT IS TO BE INSTALLED IN ACCORDANCE WITH INSTRUCTION DWG XXXXXXXX WHICH WILL BE FURNISHED BY THE GOVERNMENT TO THE KIT MANUFACTURER AND/OR INSTALLERS IN SUCH QUANTITIES AS MAY BE DEEMED NECESSARY."

When more than one instruction drawing is required, all drawings shall be listed on sheet 1.

d. When special packaging instructions are required for a kit, the following note shall be added.

"SPECIAL PACKAGING INSTRUCTIONS I23XXXX7 APPLY TO THIS KIT."

e. Special notes for QAPs and rework drawings shall be included when required.

f. An integral listing of parts with total quantities is required.

(1) When an assembly is required, only the assembly number shall be listed and not the individual detail parts.

(2) When a kit has more than one installation instruction drawing, the parts list shall be separated to satisfy the quantity requirements of each installation instruction drawing.

201.9.10.2 Rework drawing requirements. A rework drawing is used only with modification and conversion kits and shall be prepared when rework of an old part is desired rather than furnishing a new part. The requirements for rework drawings are as follows:

DOD-STD-00100D(AR)

a. A rework drawing shall depict requirements for rework of an item or assembly existing in the end item that is being modified or converted.

b. Sufficient views shall be shown to fully and clearly define the rework requirements. The rework requirements shall be shown with solid lines. The portions of the part/assembly not reworked shall be shown with phantom lines.

c. In addition to the physical rework requirements, the following information shall be included on each rework drawing:

(1) The part number of the part/assembly to be reworked.

(2) When the part/assembly is reworked so that it is interchangeable with a part/assembly of a later production configuration, the reworked part/assembly shall be reidentified to reflect the identify of the production item.

(3) When the part/assembly is reworked so that it is not interchangeable with a part/assembly of a later production configuration, the reworked part/assembly shall be identified by a new part number which will correspond with the rework drawing number.

(4) Each rework drawing shall contain the notation, "REWORK DRAWING" which will be placed directly above the title block.

201.9.10.3 Installation instruction drawing. Each kit shall have an installation instruction drawing prepared as specified herein. The drawing may range from an "A" size to a multi-sheet "K" size drawing. See FIGURE 200-36. (Reference 201.9.17).

a. For clarity, those parts on the drawing which are new, to be removed and reused, reworked, excessed, or removed and discarded shall be identified with an appropriate symbol. The symbols and their definitions as shown below shall be included in the general notes. Only the symbols required shall be used. (Size shall be approximately 1/4 inch.)

*** NEW PARTS**

△ PARTS TO BE REMOVED AND REUSED

⊕ PARTS TO BE REWORKED

PARTS TO BE REMOVED AND DISCARDED

⊖ SPECIAL INSTRUCTION NOTES (WHEN NEEDED)

□ PARTS ARE EXCESS AND CAN BE USED ELSEWHERE

DOD-STD-00100D(AR)

b. All installation drawings shall contain the note:

"THIS DRAWING IS FOR INSTALLATION PURPOSES ONLY.
ALL ITEMS MARKED* ARE INCLUDED IN KIT."

c. The drawing should clearly show the parts which are to be removed, reworked, etc., and where the kit parts are installed. Although a display of the sequence of operations is not required, the drawing must be clear enough so that an industrial facility and/or a national maintenance point (local maintenance representative) can understand the tasks to be performed and develop sequence and detailed instructions. However, if the sequence is functionally important, this data shall be specified on the drawing.

d. Drawing titles shall be descriptive of the intended installation/ modification. Example:

INSTALLATION INSTRUCTIONS
RIFLE RACKS MOUNTING MODIFICATION
KIT 570XXX2

e. The drawing shall reflect the "Before" and "After" condition of the modification. Only the parts reworked and areas affected shall be shown in solid, and the remainder of the illustration shall be in phantom.

f. When special tools are required, the tools shall be specified in the general notes.

g. The reworked item shall be identified by the assigned part number. The old part number prior to rework and the rework drawing shall be placed in parenthesis. The callout on the field of the drawing shall be as follows:

127
"COVER, 123XXXX1
(REWORK 123XXXX3 IN ACCORDANCE WITH DRAWING 123XXXX2)"

DOD-STD-00100D (AR)

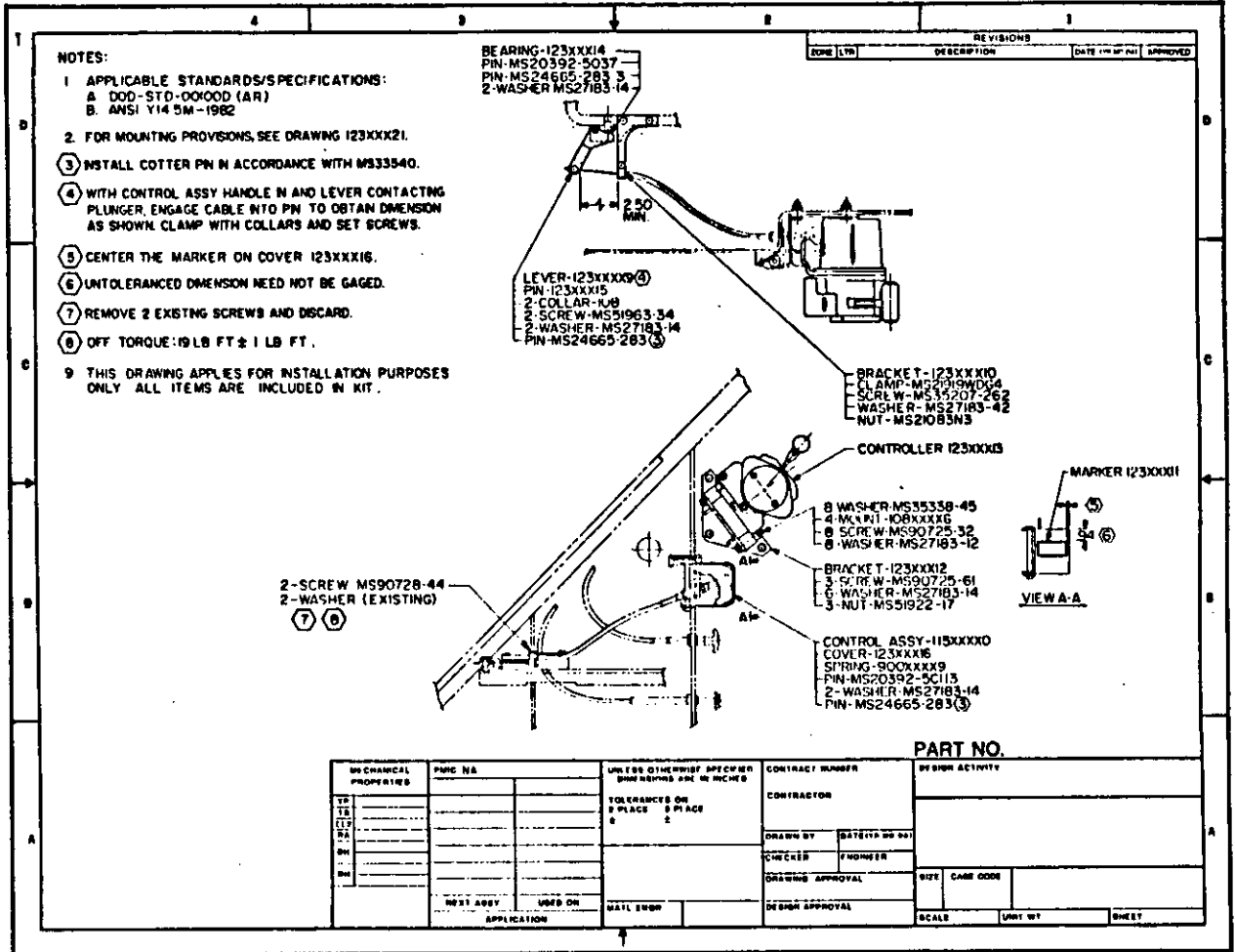

FIGURE 200-36. Installation instruction drawing

This sample drawing is informational only and complete to the degree necessary to illustrate a type of drawing. Actual format and drawing shall conform to the textual requirements set forth in this standard.

DOD-STD-00100D(AR)

201.9.11 Combinations of adopted items drawing. A combination of adopted items drawing depicts the items constituting a combination of items and assigns a unique identification number to the combination. The drawing serves as the basic document for assignment of a stock number to the combination. See FIGURE 200-37.

201.9.11.1 Requirements. Drawing format shall be in accordance with FIGURE A-8 of APPENDIX A. Entries on the drawing shall be in accordance with lettering requirements of paragraph 101.2. Entries in each column shall be as follows:

a. NATIONAL STOCK NUMBER: Self Explanatory. If no Stock Number exists, enter "NONE".

b. COMBINATIONS OF ADOPTED ITEMS: The necessary description of the combination of adopted items represented by the drawing shall be entered in the "Combinations of Adopted Items" column. The first and main entry shall be the necessary description of the combination of adopted items for which the drawing is prepared. The words "COMPOSED OF:" shall be entered below the first entry. The items contained in the combination described in the first entry shall then be listed by complete nomenclature. The quantity of each item, listed below the words "COMPOSED OF:" necessary to complete one unit of the combination shall precede the description of each item. See FIGURE 200-37.

c. CAGE CODE: The code number of the Design Activity whose part number is assigned to the item(s) listed.

d. PART NO: The part number(s) of the item(s) listed. If no Part no. exists, enter "NONE".

DOD-STD-00100D(AR)

NATIONAL STOCK NUMBER	COMBINATIONS OF ADOPTED ITEMS	CAGE CODE	PART NO.
52XX-X1-24X-38XX	CARTRIDGE, 25MM, HEI-T, M792 WITH M28 LINKS, PACKED IN CNU-405 CONTAINER COMPOSED OF:	19200	125XXX80
10X-X2-12X-39XX	1 - CARTRIDGE, 25MM, HEI-T, M792	19200	120XXX30
15XX-X3, 12X-45XX	1 - LINK ASSEMBLY, 25MM, M28, 55 LINKED CARTRIDGES	19200	120XXX13
NONE	METHOD OF PACKING 55 CARTRIDGES, 25MM, IN CNU-405 METAL CONTAINER	19200	96XXX06

PMIC NA				CONTRACT NUMBER		DESIGN ACTIVITY	
REVISIONS				CONTRACTOR		COMBINATION OF ADOPTED ITEMS:	
LTR	DESCRIPTION	DATE	APPR	DRAWN BY	DATE (YR-MO-DA)		
				CHECKER	ENGINEER	SIZE CAGE CODE 19200 125XXX80	
				DRAWING APPROVAL			
				DESIGN APPROVAL		UNIT WT	SHEET

FIGURE 200-37. Combination of adopted items drawing

This sample drawing is informational only and complete to the degree necessary to illustrate a type of drawing. Actual format and drawing shall conform to the textual requirements set forth in this standard.

130

DOD-STD-00100D(AR)

201.9.12 Ship equipment (marine item) drawing. A ship equipment drawing depicts components, equipment and systems, e.g., pumps or radar systems that may be used on one or more ships. See FIGURE 200-38.

201.9.12.1 Requirements. Ship equipment drawings shall be considered for each application in three divisions, as follows:

a. Equipment drawings previously accepted for shipboard use and also approved for the particular application.

b. Equipment drawings previously accepted for shipboard use but not approved for the particular application.

c. Equipment drawings not previously accepted for shipboard use.

201.9.12.2 Weight. The net weight and also the operating weight with fluids, where applicable, shall be indicated. In addition, the vertical, longitudinal, and transverse location of the center of gravity (wet or dry, as appropriate) of each separate ship-installed unit or assembly weighing 100 pounds or more shall be shown on the outline drawings, assembly drawings, manufacturer's control drawings, or installation drawings.

201.9.12.2.1 Weights of units and assemblies shown on ship construction drawings shall be entered in the parts lists.

201.9.12.3 Conformance with specification. A statement shall be made on the Certification Data Sheet, assembly drawings, or outline drawings, as applicable, that "THIS EQUIPMENT IS IN ACCORDANCE WITH SPECIFICATION Number, (including revisions and amendments)." or "THIS EQUIPMENT IS IN ACCORDANCE WITH SPECIFICATION Number, (including revisions and amendments). WITH THE FOLLOWING EXCEPTIONS: *Cite Applicable Exceptions.*"

DOD-STD-00100D(AR)

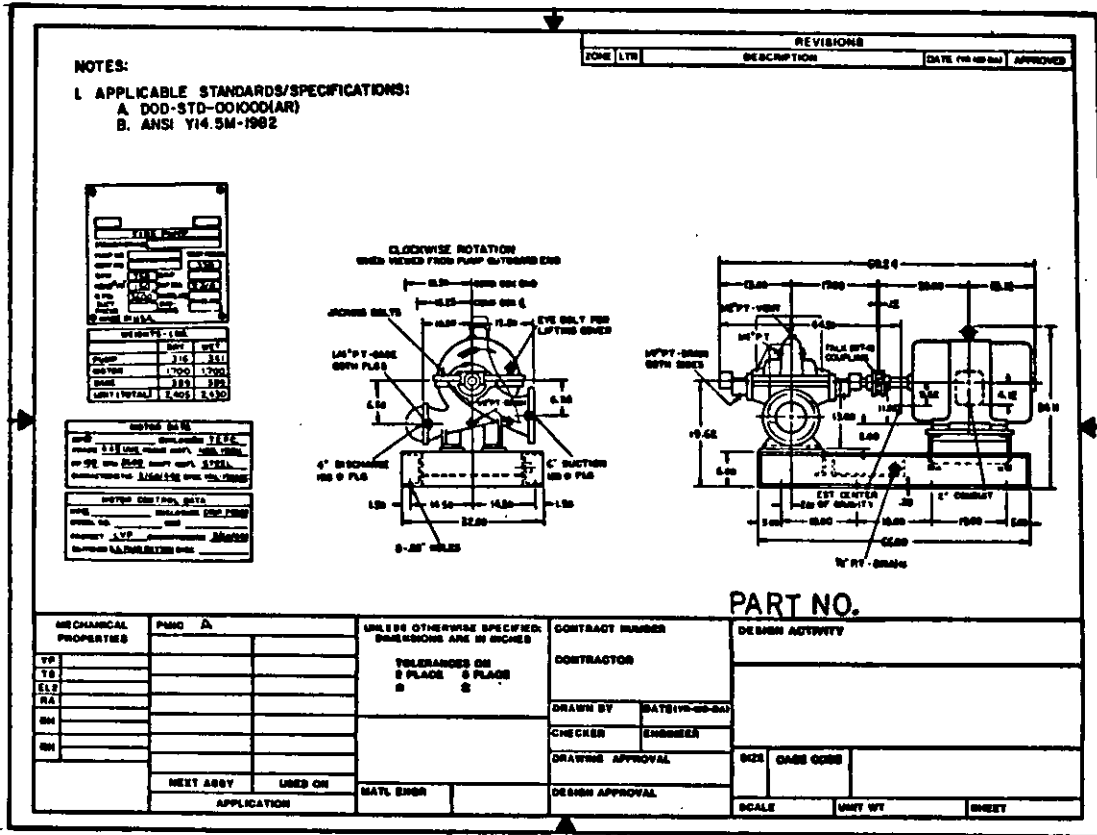

FIGURE 200-38. Ship equipment (marine item) drawing

This sample drawing is informational only and complete to the degree necessary to illustrate a type of drawing. Actual format and drawing shall conform to the textual requirements set forth in this standard.

DOD-STD-00100D(AR)

201.9.13 Certification data sheet. Certification data sheets are supplementary drawings which contain certain contract data, equipment characteristics data, drawing references, etc., which are contractually required to be furnished for each contract, purchase order, or equipment produced or procured by a contractor, except when an outline drawing, drawing list, or other type of document is specified in lieu of a certification data sheet. In that event, the applicable certification data shall be included in the document specified. See FIGURE 200-39.

201.9.13.1 Contents. Certification data sheets shall include the following, as applicable:

- a. Manufacturer's drawing number assigned to identify the certification data sheet.
- b. Manufacturer's drawing number and revision symbol of drawing(s) for which the certification data sheets are prepared.
- c. Specifications applicable to the equipment, date of specification(s), and any exceptions thereto.
- d. Government contract or order number(s) and the contractor's order number(s) and date(s).
- e. Manufacturer's order number.
- f. Manufacturer's identification, rating of equipment, model number, and other pertinent information.
- g. Ship system where used.
- h. Ship identification number(s) when known.
- i. Number of items per ship and per contract, when known.
- j. Reference drawings, including applicable certification data sheets (unless other provided), giving manufacturer's drawing number (e.g., exciter, controller, rheostat, complete unit assembly drawings, and related drawings).
- k. Technical manual number, if available.
- l. Component Identification Number (Allowance Parts List Number), if available.
- m. Additional data such as remarks, notes, or selection of design variation applicable to the contract or order.
- n. Certifying signature of contractor's representative. Government certification is not required.
- o. File number and date of letter of design acceptance, when applicable.
- p. Design deviations, if any. These deviations must be of such minor nature that existing ship equipment drawings can be made applicable to later ships or classes of ships without change by indicating on the ship construction drawings the minor deviations from the basic design.

DOD-STD-00100D(AR)

APPLICATION		REVISIONS			
NEXT ASSY	USED ON	LTR	DESCRIPTION	DATE (YR-MO-DY)	APPROVED
<p>NOTES:</p> <ol style="list-style-type: none"> APPLICABLE STANDARDS/SPECIFICATIONS. <ol style="list-style-type: none"> DOD-STD-00100D (AR) MIL-D-1706 MIL-L-15719 CONTRACT OR ORDER No.: N0000X-XX-C-XXXX CONTRACTOR'S ORDER No.: XXXX-XXXX EQUIPMENT DRAWING No.: 123XXXX7 SPECIFICATIONS: MIL-M-1706 APPLICATION: FIRE PUMP CHARACTERISTICS: 125 HP, 3600 SYN RPM, 3 PHASE, 60 HERTZ NUMBER OF SHIPS: 1 UNITS PER SHIP: 6 UNITS PER CONTRACT: 6 ASSOCIATED DRAWINGS: (EQUIPMENT/DRAWING No./MANUFACTURER/ETC.) AUXILIARY PUMP/187-B-1899/XXXX MFG CO/CAT. No. 187-B-1899-6S1, 6S2 TECHNICAL MANUAL No.: 0947-222-0010 COMPONENT IDENTIFICATION DESIGNATOR: 123XXXX4 SHOCK TESTS NOT REQUIRED ON THIS ORDER BEARINGS SUPPLIED WITH GREASE PER MIL-L-15719 CERTIFIED CORRECT FOR ORDERS LISTED: <p style="margin-left: 40px;">CERTIFIED BY: JOHN HARDWORKER DATE: 87-02-03</p> 					
P/MC NA UNLESS OTHERWISE SPECIFIED: DIMENSIONS ARE IN INCHES TOLERANCES ON 2 PLACE 3 PLACE ± ±		CONTRACT NUMBER CONTRACTOR DRAWN BY DATE (YR-MO-DY) CHECKER ENGINEER		DESIGN ACTIVITY SIZE CAGE CODE SCALE UNIT WT SHEET	
MATL ENDR		DESIGN APPROVAL			

FIGURE 200-39. Certification data sheet

This sample drawing is informational only and complete to the degree necessary to illustrate a type of drawing. Actual format and drawing shall conform to the textual requirements set forth in this standard.

DOD-STD-00100D(AR)

201.9.14 Correlation drawing. A correlation drawing depicts physical and functional engineering requirements between or among components of a subsystem. They are used to correlate interface engineering data between a subsystem design activity and others involved in the design of the subsystems.

201.9.14.1 Requirements. The requirements prescribed for interface control drawings (paragraph 201.4.6.1) shall apply to correlation drawings, except the delineation provided on correlation drawings shall be restricted to components within the subsystems. Correlation drawings shall not contain requirements intended to control interfaces of associated subsystems. The notation, "CORRELATION DRAWING" shall be shown, adjacent to the title block. Data prescribed on correlation drawings which cannot be changed without affecting co-functioning subsystems shall be suitably identified.

201.9.15 Formulation drawing. A formulation drawing depicts the constituents of an explosive, propellant, pyrotechnic, filler, etc. It is used to discretely identify (see paragraph 402.16.3) the mixture; its weight, volume, or particle size as used within the particular formulation. See FIGURE 200-40.

201.9.15.1 Requirements. Formulation drawings are textual drawings which, as a minimum, disclose and identify a chemical mixture or compound by use of a discrete identification. In addition, the weight, volume, percentage composition, or particle size of the chemical or compound making up the formulation shall be defined along with the necessary batching and processing steps required to attain the required formulation. "FORMULATION DRAWING" shall be shown, adjacent to the title block.

135

DOD-STD-00100D (AR)

APPLICATION		REVISIONS			
NEXT ASSY	USED ON	LTR	DESCRIPTION	DATE (YY-MM-DD)	APPROVED

INGREDIENTS	PERCENTAGE BY WEIGHT
LAMIMAC 4116, DWG 115XXXX NOTE 3	98.5 ± 1.0
LUPEROL DDM, DWG 111XXXX NOTE 4	1.0 ± 0.5
COBALT NAPHTHENATE DWG 117XXXX	0.5 ± 0.1

NOTES:

1. APPLICABLE SPECIFICATIONS/STANDARDS.
A. DOD-STD-00100D (AR)
2. USE MIXTURE WITHIN 15 MINUTES AFTER MIXING.
3. STORAGE TEMPERATURE 60 F MAX. SHALL NOT BE USED IF SOLIDIFIED. SHELF LIFE APPROXIMATELY 6 MONTHS.
4. STORAGE TEMPERATURE 45 F MAX. SHALL NOT BE USED IF SOLIDIFIED. SHELF LIFE APPROXIMATELY 6 MONTHS.

FORMULATION DRAWING

PART NO.

PM10 A UNLESS OTHERWISE SPECIFIED: DIMENSIONS ARE IN INCHES TOLERANCES ON 3 PLACE 3 PLACE ± ±	CONTRACT NUMBER		DESIGN ACTIVITY		
	CONTRACTOR				
	DRAWN BY	DATE (YY-MM-DD)			
	CHECKER	ENGINEER			
	DRAWING APPROVAL		SIZE	GAGE CODE	
MATL ENDR	DESIGN APPROVAL		SCALE	UNIT WT	SHEET

FIGURE 200-40. Formulation drawing

This sample drawing is informational only and complete to the degree necessary to illustrate a type of drawing. Actual format and drawing shall conform to the textual requirements set forth in this standard.

DOD-STD-00100D(AR)

201.9.16 Contour definition drawing. A drawing containing the mathematical, numeric or graphic definition required to locate any desired point on a given contoured surface. This drawing is used for either conventional or computer assisted part fabrication.

201.9.16.1 Requirements. The drawing shall contain mathematical equations for each geometric entity, tabulated coordinates, graphic sections, summary of entities and relationship(s) to more basic coordinate systems.

201.9.17 Modification drawings. Modification drawings delineate changes to delivered items, assemblies, installations or systems. Modification drawings are prepared to add, remove or rework item equipment installations, or systems to satisfy the using activity's requirements or to incorporate mandatory changes (i.e., safety, reliability, or application extension) in delivered equipment. Indicate above or adjacent to the title block the words "MODIFICATION DRAWING". (Reference 201.9.10.3).

201.9.17.1 Requirements. Modification drawings shall contain complete information for accomplishing the change, including, as applicable:

- a. Instructions for the removal or installation of affected parts.
- b. Special notes, including identification by part drawing number of modified part.
- c. Dimensions necessary to accomplish the modification. (These shall be given from some specific point which is readily identified and accessible, rather than from some theoretical reference plane).
- d. An integral parts list containing all items required for the modification, items to be deleted, salvaged, and items to compile a kit, as applicable.
- e. Listing of special tools or equipment required or supplied.
- f. Effectivity (serial number, aircraft tail number) which will identify the items which are to be modified.

201.10 Layout drawing. A layout drawing provides graphic depiction of design development. It is similar to a detail, assembly or installation drawing, except that it contains only the minimum number of lines necessary to resolve pictorially the design solution. A layout drawing does not establish item* identification. See FIGURE 200-41.

201.10.1 Application guidelines. A layout drawing may be prepared for a complete end product* or any portion thereof and is prepared either as:

- a. A conceptual design layout to present one or more solutions for meeting the basic design parameters and to provide a basis for evaluation and selection of an optimum design approach.

DOD-STD-00100D(AR)

b. A design approval layout to present sufficient details of the design approach for cost estimating and design approval.

c. A detailed design layout depicting the final development of the design in sufficient detail to facilitate preparation of detail and assembly drawings.

d. A geometric study to develop movement of mechanical linkages, clearances or arrangements.

A layout drawing is not normally used to fabricate equipment; however, a detailed design layout drawing is sometimes used as an interim drawing for development items.

201.10.2 Requirements. A layout drawing shall include, as applicable:

a. Location of primary components.

b. Interface and envelope dimensions including a cross reference to applicable interface control documentation.

c. Paths of motion.

d. Operating positions.

e. Critical fits and alignments.

f. Selected materials, finishes, and processes.

g. Wire bundle and pneumatic and hydraulic line routing and sizes.

h. Adjustments.

i. Critical assembly details and sequence.

j. Identification for selected purchased items and new design items.

k. Identification for assembly depicted (when the layout drawing is to be used as an interim assembly drawing).

A layout shall be drawn to scale with sufficient accuracy and completeness for its intended use.

DOD-STD-00100D(AR)

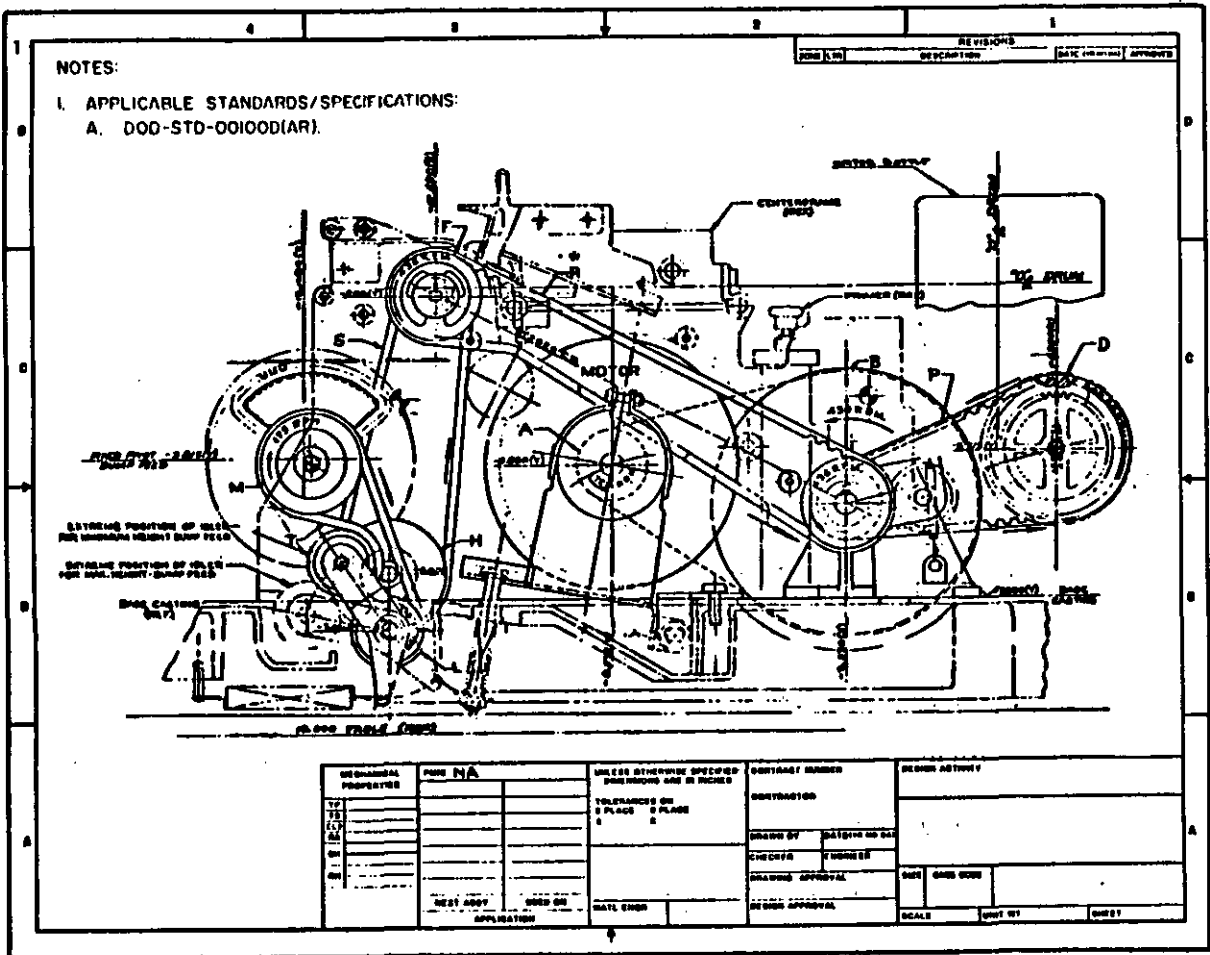

FIGURE 200-41. Layout drawing

This sample drawing is informational only and complete to the degree necessary to illustrate a type of drawing. Actual format and drawing shall conform to the textual requirements set forth in this standard.

201.11 Camouflage basis drawing. A camouflage basis drawing graphically depicts exterior configuration (outline) of all items that require a camouflage pattern. Deviations or exclusions must be approved by RD&E Center, Camouflage Applications Team, ATTN: STRBE-JDA, Ft. Belvoir, VA 22060-5606.

201.11.1 Requirements. A camouflage basis drawing shall include the following requirements and information as a minimum.

a. Drawings shall depict the following views.

- (1) Back
- (2) Front
- (3) Top
- (4) Right Side
- (5) Left Side
- (6) All hidden views, including open position of hatches and doors.

b. The drawing scale is dependent upon the actual size of the item as follows:

(1) Items whose overall length is twenty five (25) feet or less, the drawing scale shall be one eighth (1/8).

(2) Items whose overall length is greater than twenty five (25) feet, the drawing scale shall be one tenth (1/10).

(3) Items with excessive dimensions shall be scaled proportionate to the size of the item. The scale to be used shall be approved by Ft. Belvoir RD&E Center.

c. Drawing sheet size shall be "D" or "E" in accordance with ANSI Y14.1.

d. Overall dimensions shall be shown to define length, width, and height of the item. Also any dimensions required to position the item prior to application of the pattern shall be shown.

e. Depictional detail shall be sufficiently accurate to show reference points from which the dimensions emanate.

f. Towed items shall be shown in the towed position. The type(s) of vehicle that will be used to tow the item shall be specified.

g. Fire control and basic issue items shall be shown in the installed position.

h. Hatches/doors that could be left in the open position during operating mode on self-propelled and vehicular items shall be shown in both the open and the closed position.

i. It is preferred that ink be used for drawing and that line width be narrow enough to permit depiction of necessary details without lines blending together.

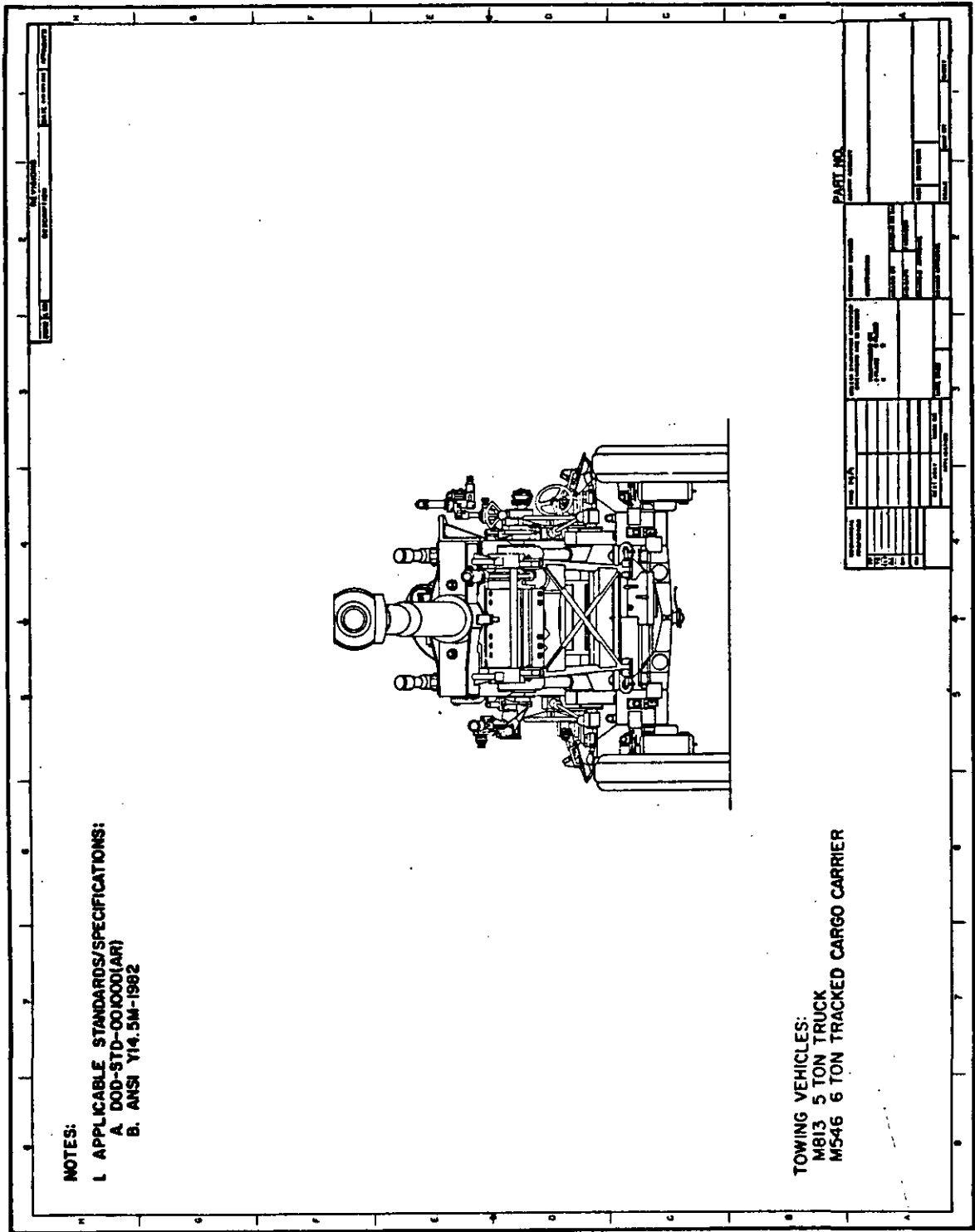

FIGURE 200-42. Camouflage basis drawing

This sample drawing is informational only and complete to the degree necessary to illustrate a type of drawing. Actual format and drawing shall conform to the textual requirements set forth in this standard.

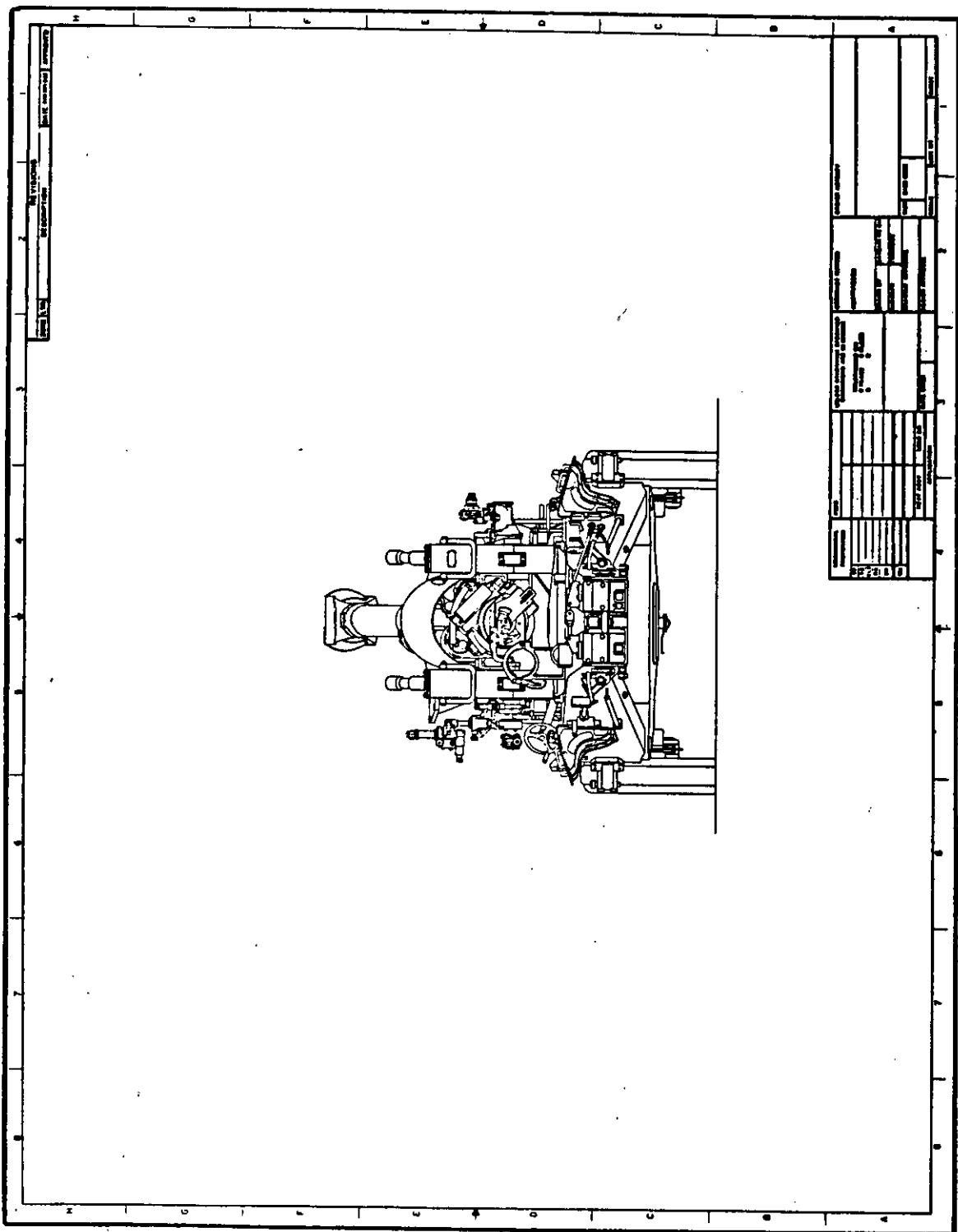

FIGURE 200-42. Camouflage basis drawing (Cont.'d)

142

This sample drawing is informational only and complete to the degree necessary to illustrate a type of drawing. Actual format and drawing shall conform to the textual requirements set forth in this standard.

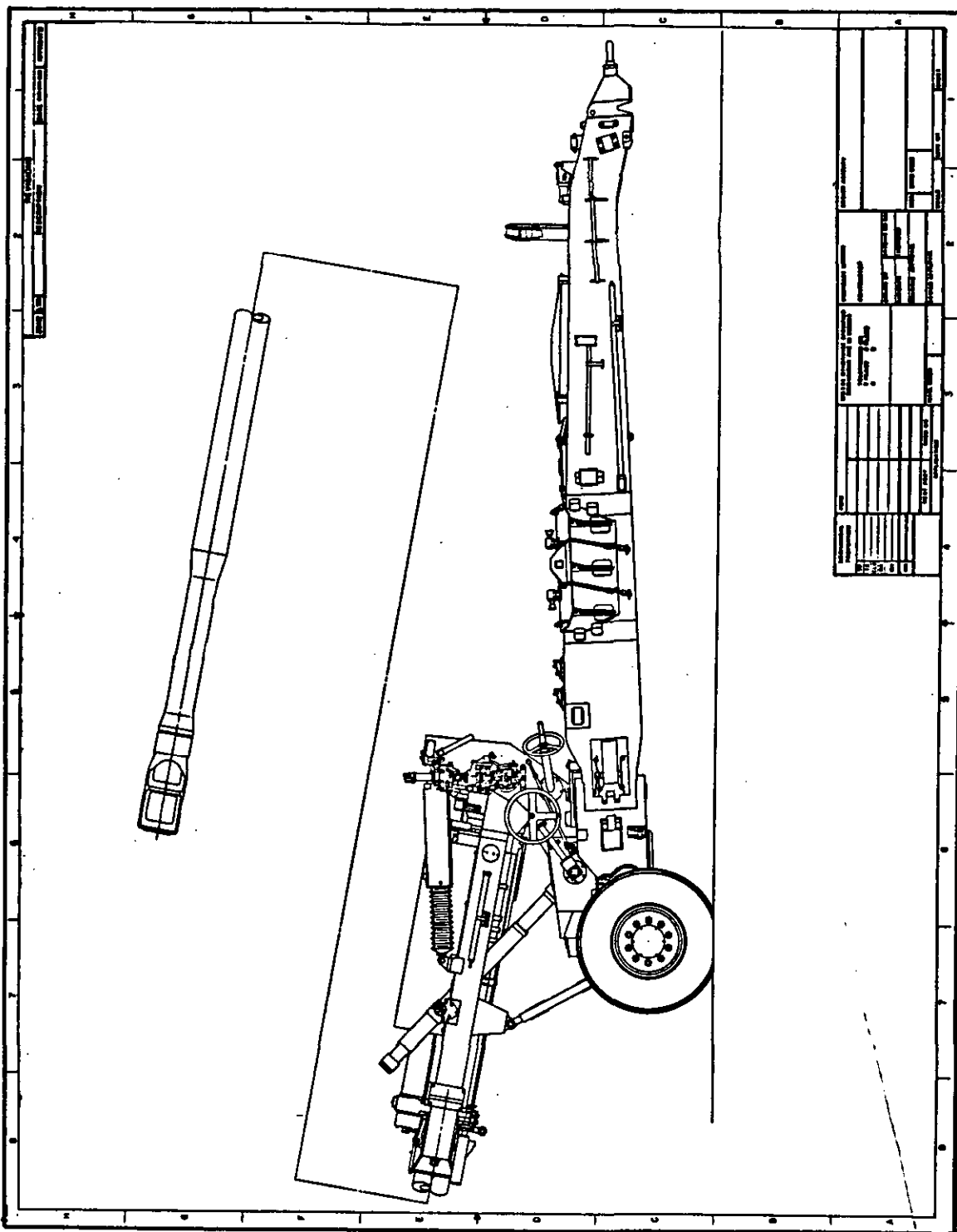

FIGURE 200-42. Camouflage basis drawing (Cont'd)

This sample drawing is informational only and complete to the degree necessary to illustrate a type of drawing. Actual format and drawing shall conform to the textual requirements set forth in this standard.

143

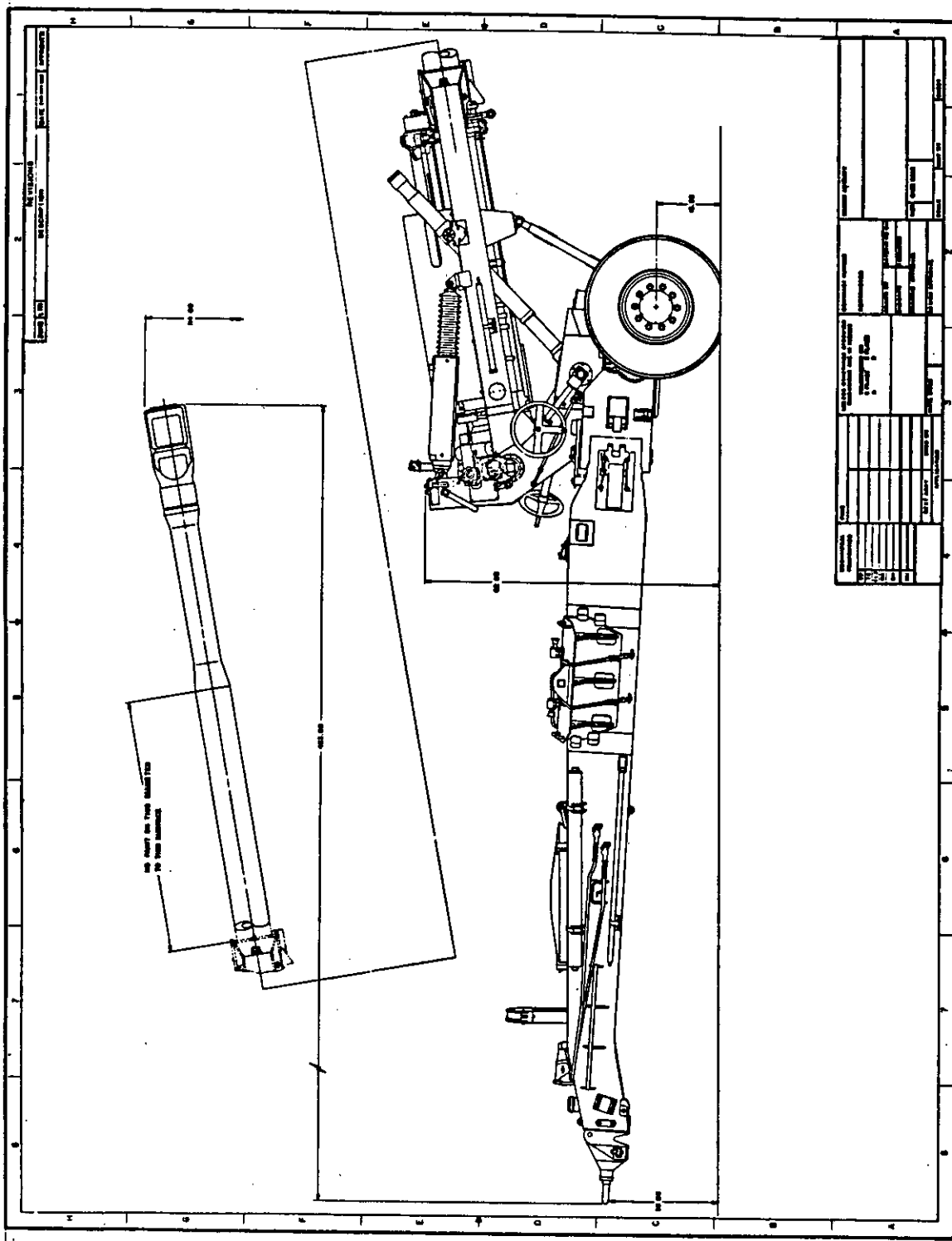

FIGURE 200-42. Camouflage basis drawing (Cont'd)

144

This sample drawing is informational only and complete to the degree necessary to illustrate a type of drawing. Actual format and drawing shall conform to the textual requirements set forth in this standard.

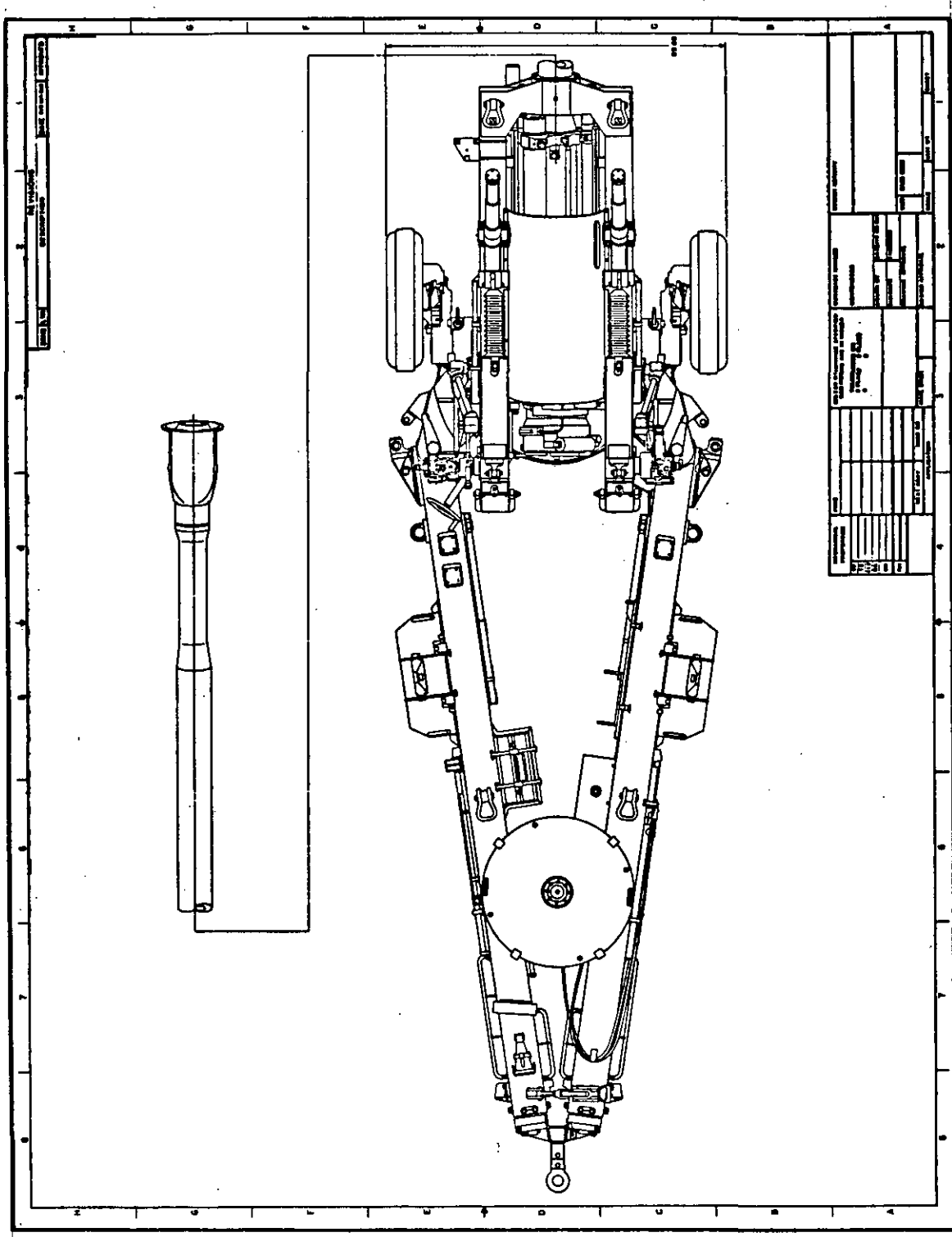

FIGURE 200-42. Camouflage basis drawing (Cont'd)

This sample drawing is informational only and complete to the degree necessary to illustrate a type of drawing. Actual format and drawing shall conform to the textual requirements set forth in this standard.

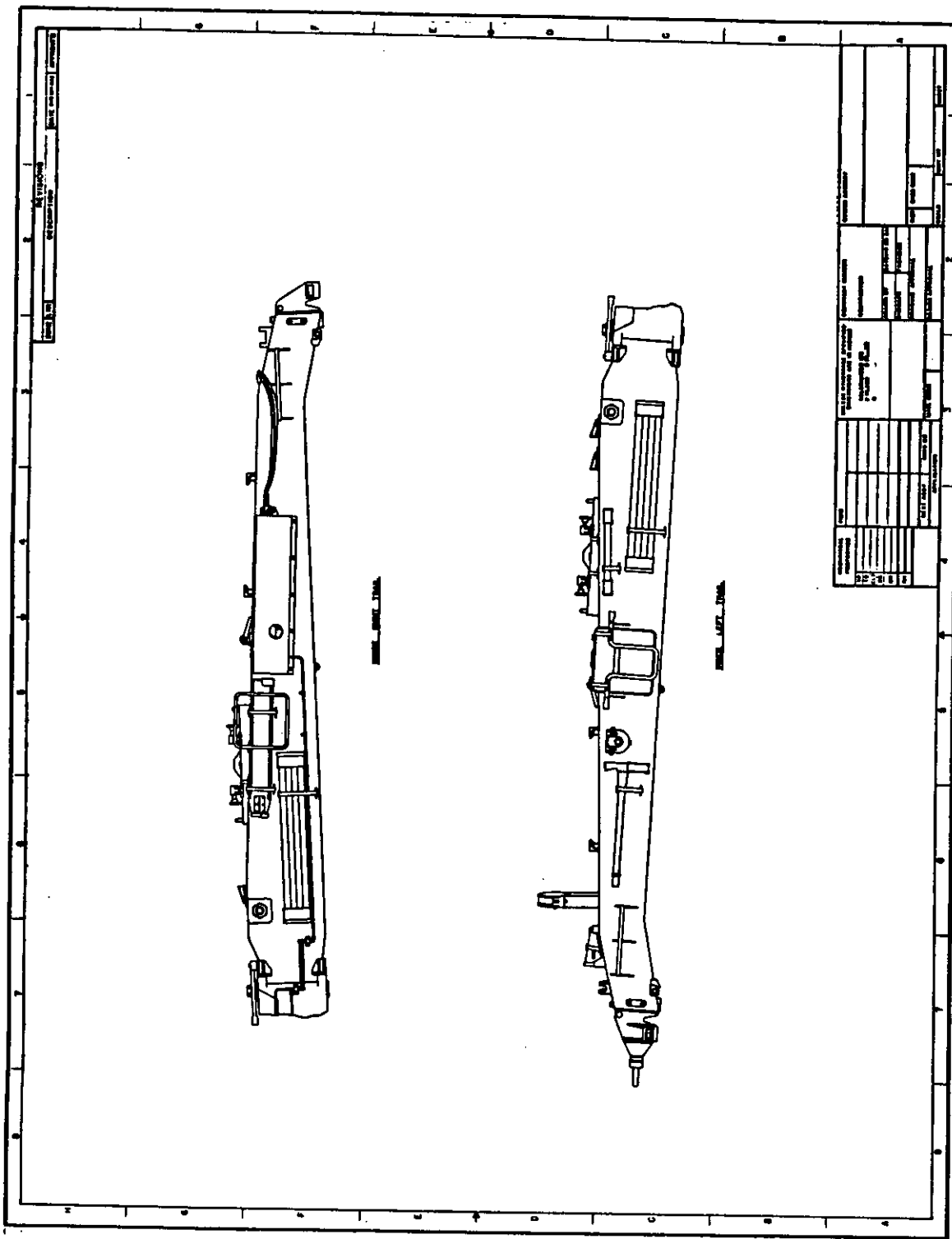

FIGURE 200-42. Camouflage basis drawing (Cont'd)

146

This sample drawing is informational only and complete to the degree necessary to illustrate a type of drawing.. Actual format and drawing shall conform to the textual requirements set forth in this standard.

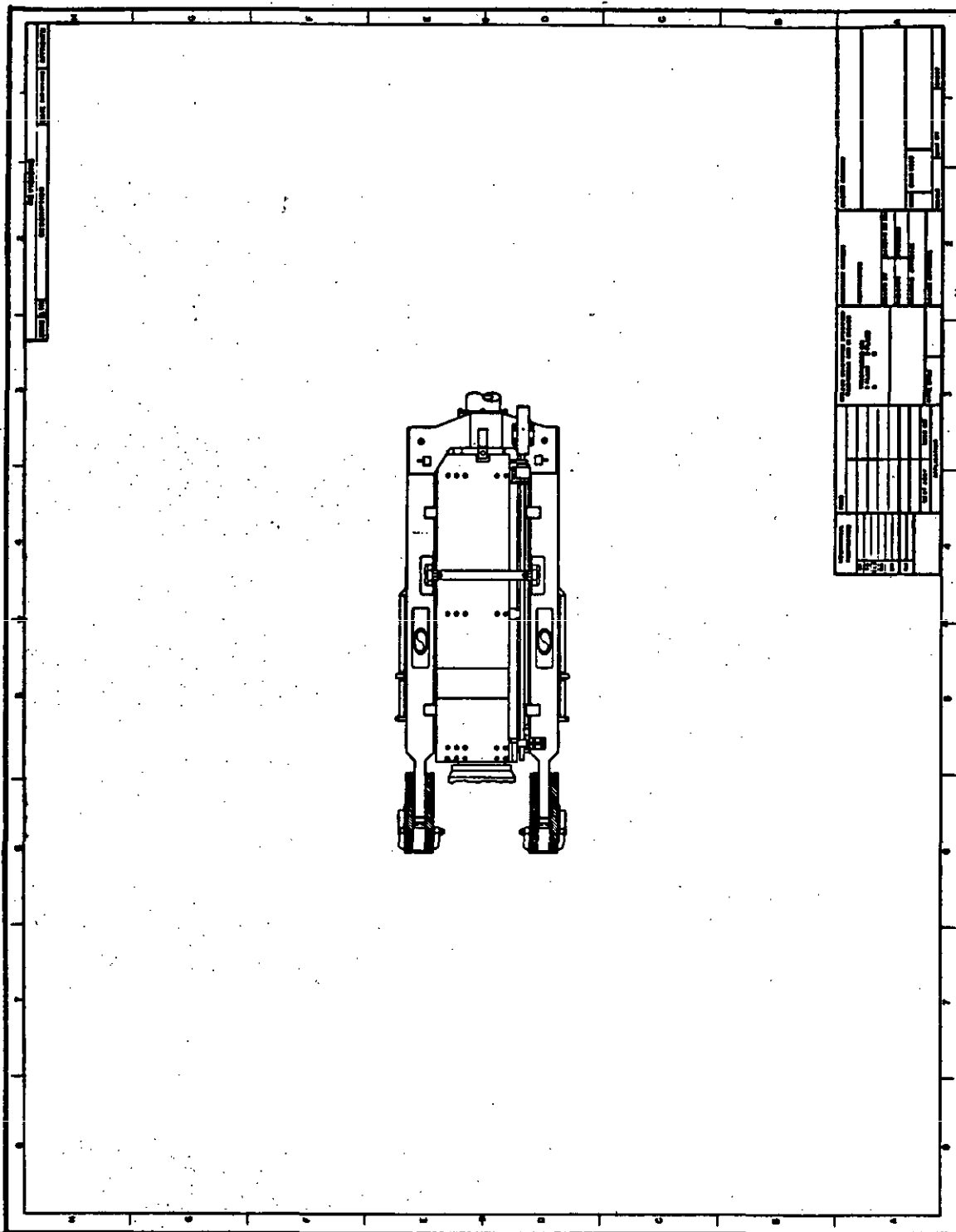

FIGURE 200-42. Camouflage basis drawing (Cont'd)

This sample drawing is informational only and complete to the degree necessary to illustrate a type of drawing. Actual format and drawing shall conform to the textual requirements set forth in this standard.

DOD-STD-00100D(AR)

201.12 Camouflage pattern drawing. The camouflage pattern drawing depicts the system and requirements for the contrasting color bands and patches applied over a base color to disrupt the silhouette of an item as observed from 1000 meters and beyond. Generation of the pattern is the responsibility of Ft. Belvoir RD&E Center. Changes and/or adjustments to the pattern requires approval of Ft. Belvoir. See FIGURE 200-43.

201.12.1 Requirements. The camouflage pattern drawing shall describe the pattern generated by Ft. Belvoir RD&E Center. The following requirements shall be included:

a. The location and size dimensions for bands as required. The black disruptive bands shall be within \pm one (1) inch of the specified width of the band, and the relation of the band shall be within \pm one (1) inch of the specified assigned location on the item as depicted by the drawing.

b. Notes as required.

c. Marking style, size, location, and color of paint to be applied.

d. Identification of all surfaces not to be painted.

e. Type of paint in accordance with MIL-STD-171. Chemical Agent Resistant Coating (CARC) is required.

f. Cross reference to Ft. Belvoir drawing number, date and revision of their drawing describing the camouflage pattern.

DOD-STD-00100D(AR)

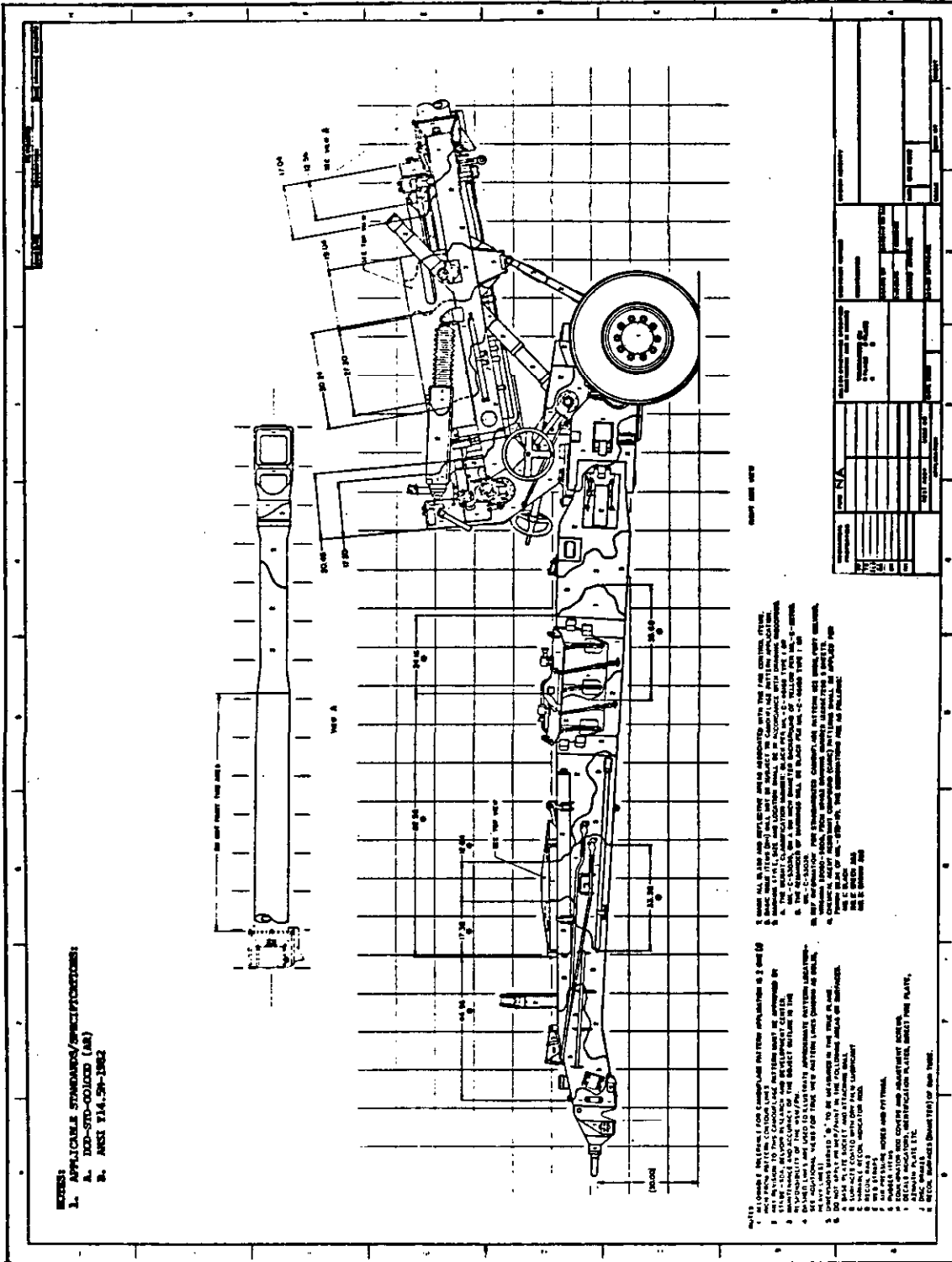

This sample drawing is informational only and complete to the degree necessary to illustrate a type of drawing. Actual format and drawing shall conform to the textual requirements set forth in this standard.

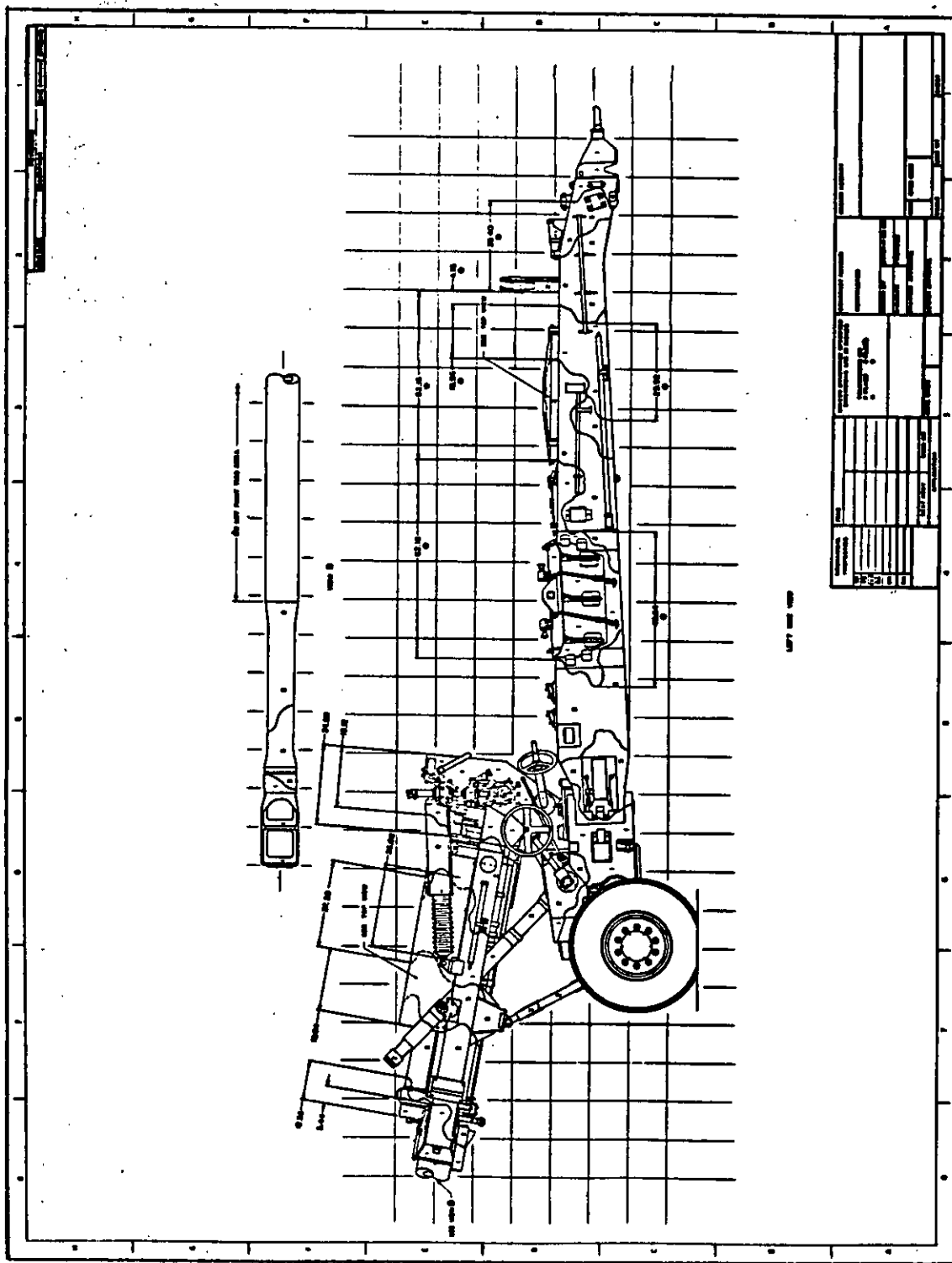

FIGURE 200-43. Camouflage pattern drawing (Cont'd)

150

This sample drawing is informational only and complete to the degree necessary to illustrate a type of drawing. Actual format and drawing shall conform to the textual requirements set forth in this standard.

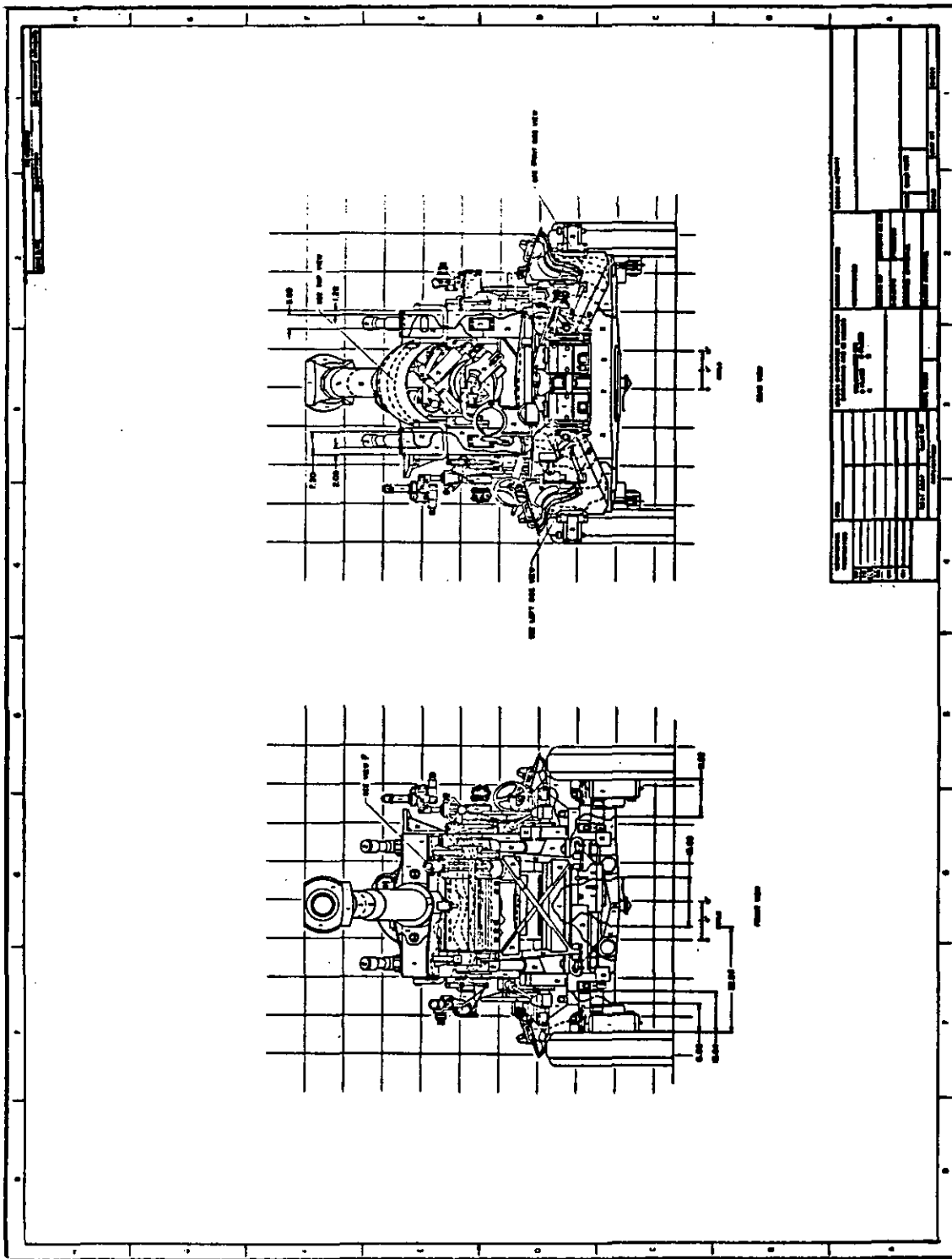

FIGURE 200-43. Camouflage pattern drawing (Cont'd)

This sample drawing is informational only and complete to the degree necessary to illustrate a type of drawing. Actual format and drawing shall conform to the textual requirements set forth in this standard.

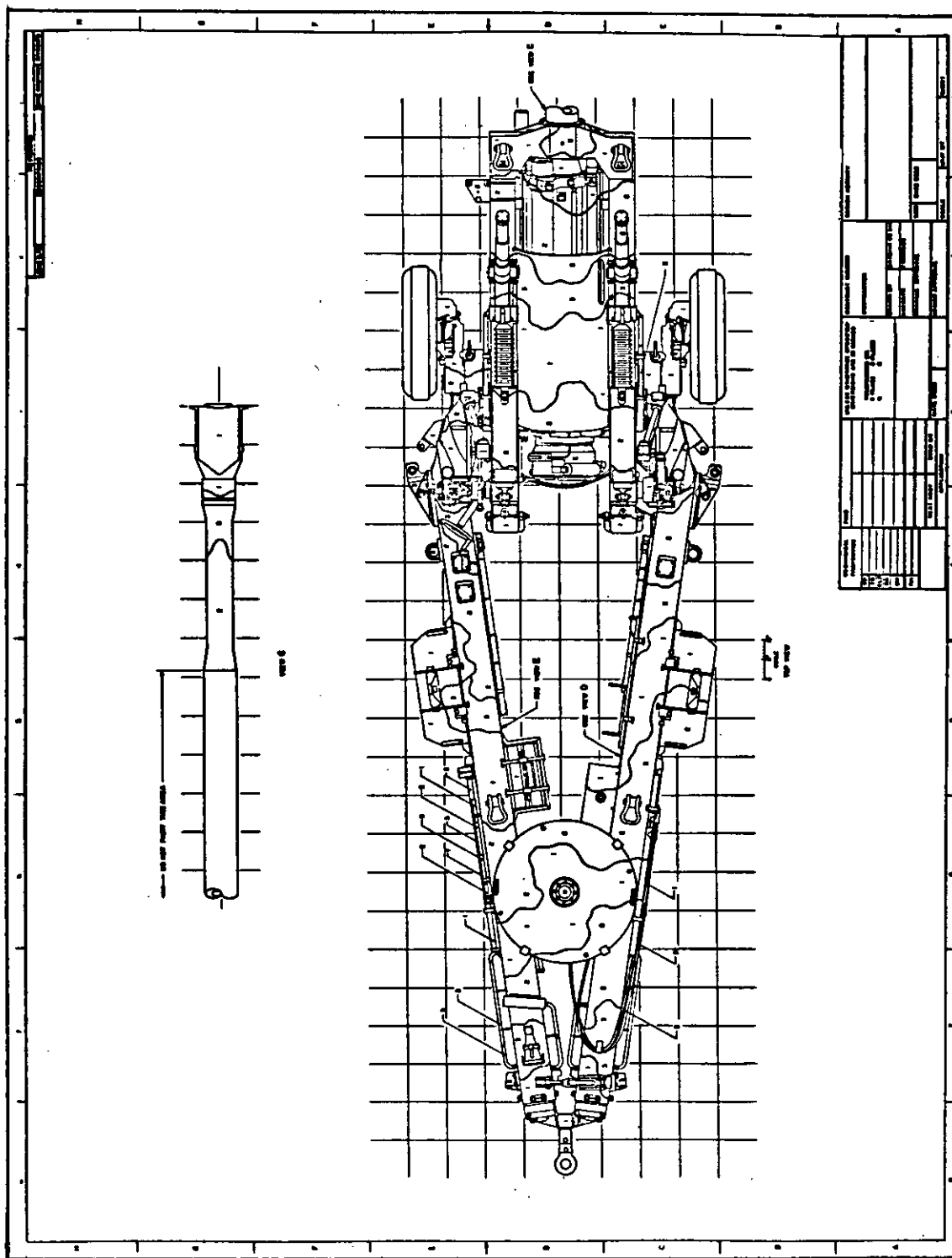

FIGURE 200-43. Camouflage pattern drawing (Cont.'d)

152

This sample drawing is informational only and complete to the degree necessary to illustrate a type of drawing. Actual format and drawing shall conform to the textual requirements set forth in this standard.

DOD-STD-00100D(AR)

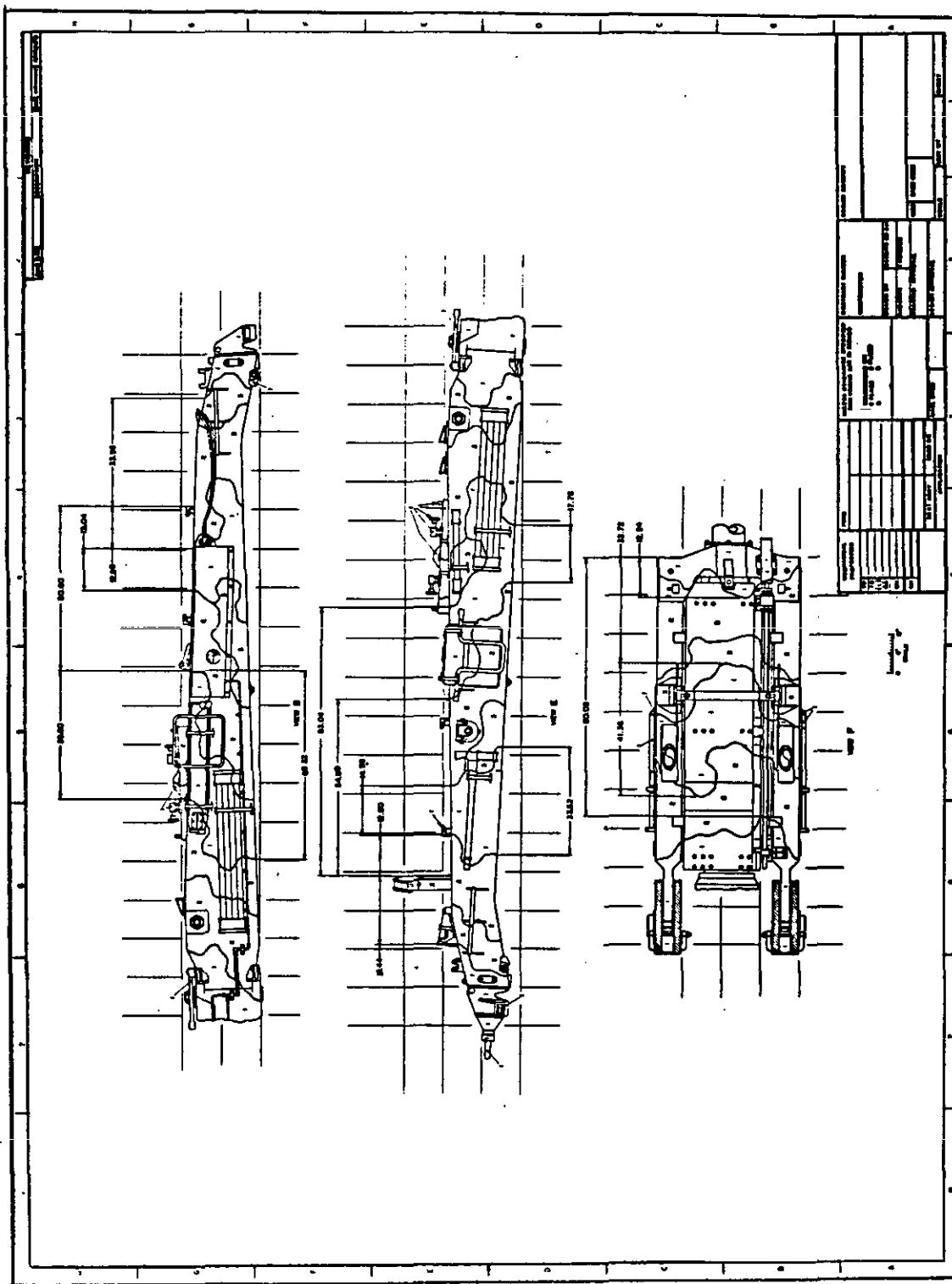

FIGURE 200-43. Camouflage pattern drawing (Cont'd)

This sample drawing is informational only and complete to the degree necessary to illustrate a type of drawing. Actual format and drawing shall conform to the textual requirements set forth in this standard.

DOD-STD-00100D(AR)

201.13 Vehicle drawing. (top assembly) A vehicle top assembly drawing depicts configuration of the vehicle. See FIGURE 200-44.

201.13.1 Requirements. A top assembly vehicle drawing shall include the following requirements and information as a minimum.

- a. Drawings shall depict the following views.
 - (1) Back
 - (2) Front
 - (3) Top
 - (4) Curb Side (Right Side)
 - (5) Road Side (Left Side)
- b. The drawing scale is dependent upon the actual size of the vehicle.
 - (1) Vehicles whose overall length is twenty five (25) feet or less, the drawing scale shall be one eighth (1/8).
 - (2) Vehicles whose overall length is greater than twenty five (25) feet, the drawing scale shall be one tenth (1/10).
- c. Drawing sheet size shall be "E" in accordance with ANSI Y14.1.
- d. Dimensions shall define the length, width, height, and location of the center of gravity (CG), lifting points and tie downs.
- e. Depictional detail shall be sufficiently accurate to indicate reference points from which dimensions emanate.
- f. All pertinent vehicle characteristics shall be listed, such as weight, size, type of engine, performance, armament and personnel capacity.
- g. Vehicle markings, as required, shall be indicated and located.
- h. The information to be added to the data or nameplate shall be specified in the general notes.
- i. The general notes will also include the applicable final inspection record and references to the interface control and electrical interconnection drawings.
- j. All associated lists such as, On Vehicle Equipment (OVE), Special Tool Sets, Special Kits, and vehicle specification shall be listed.

201.14 Vehicle camouflage pattern drawing. See 201.12. See FIGURE 200-45.

201.14.1 Requirements. See 201.12.1.

DOD-STD-00100D(AR)

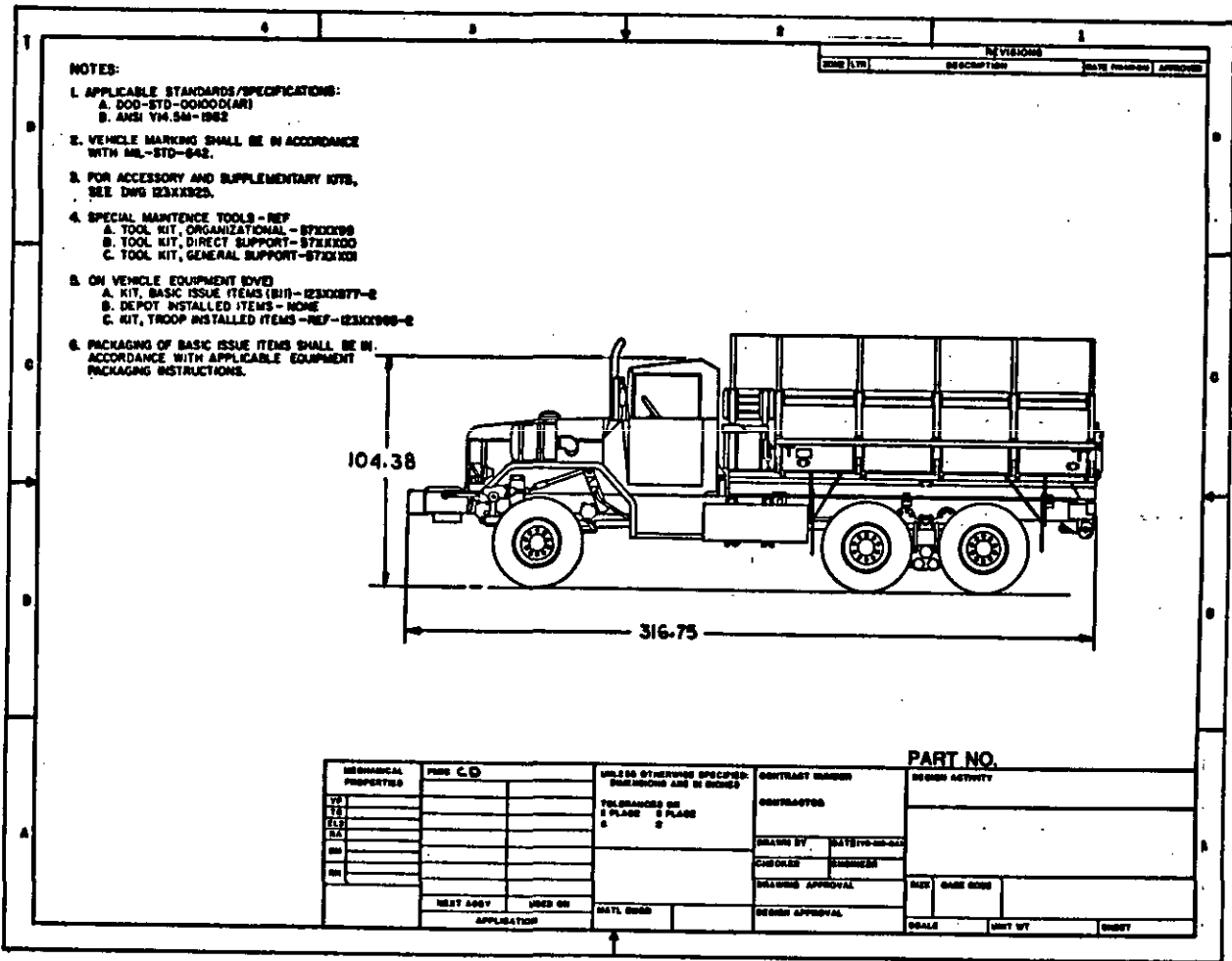

FIGURE 200-44. Vehicle drawing (top assembly)

This sample drawing is informational only and complete to the degree necessary to illustrate a type of drawing. Actual format and drawing shall conform to the textual requirements set forth in this standard.

DOD-STD-00100D(AR)

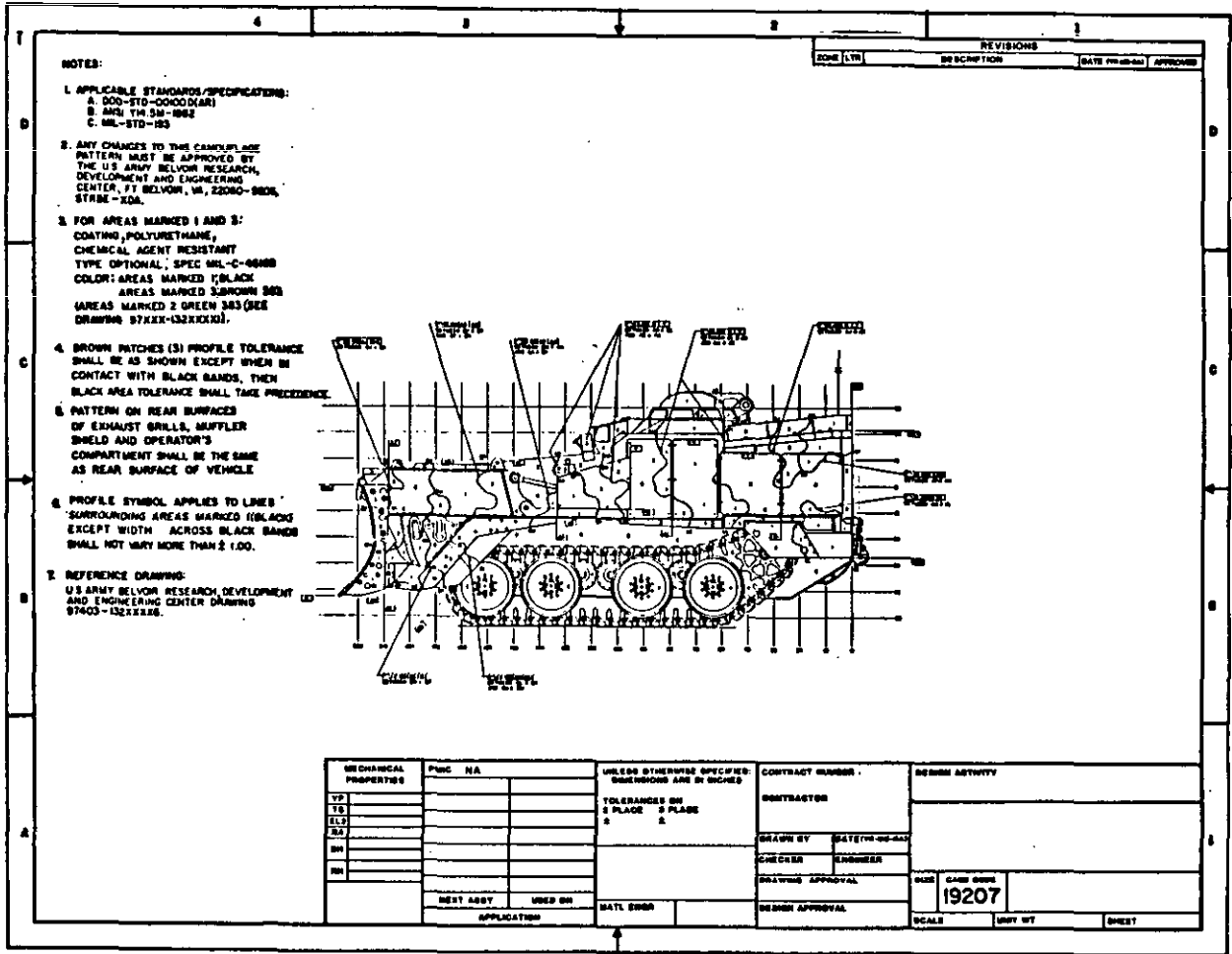

FIGURE 200-45. Vehicle camouflage pattern drawing

This sample drawing is informational only and complete to the degree necessary to illustrate a type of drawing. Actual format and drawing shall conform to the textual requirements set forth in this standard.

DOD-STD-00100D(AR)

201.15 Package content drawing. A package content drawing is a drawing prepared to provide a package identification number and appropriate package nomenclature for stock identification of military materiel packaged for convenience of handling, storage, issue, or functional selectivity in logistic support operations. Package content drawings are prepared for that packaging which constitutes a synthetic grouping or combination of items, which in themselves do not constitute a functioning, engineering, or production assembly. Representative examples of such groupings are sets of repair parts and engine and container units. See FIGURE 200-46.

201.15.1 Requirements. Drawing format shall be in accordance with FIGURE A-9 of APPENDIX A. Entries on the drawing shall be in accordance with lettering requirements of paragraph 101.2, except titles may also be typewritten. Entries shall be as follows:

- a. **PACKAGE STOCK NO.:** The National Stock Number assigned to the package.
- b. **PACKAGE NOMENCLATURE:** The nomenclature of the package.
- c. **THIS PACKAGE PERTAINS TO:** The nomenclature and model number or, if model number does not apply, the part number of the system/subsystem to which the package applies.
- d. **QTY:** The quantity of each item which is necessary to make up one unit of the package.
- e. **NAME OF ITEM:** Nomenclature of each item contained in the package.
- f. **DWG NO.:** The drawing number of each item listed.
- g. **CAGE CODE:** The code number of the Design Activity whose drawing number is assigned to the items listed.
- h. **PART NO.:** The part number of each item listed.
- i. **STOCK NO.:** The National Stock No. of each item listed. If no Stock Number exists, leave blank.
- j. **Title Block:** The nomenclature of the package contents drawing.

DOD-STD-00100D(AR)

PACKAGE STOCK NO. _____
PACKAGE NOMENCLATURE M240 MACHINE GUN INSTALLATION
THIS PACKAGE PERTAINS TO M60 TANK
PACKAGE CONTENTS

QTY	NAME OF ITEM	DWG NO.	CAGE CODE	PART NO.	STOCK NO.
1	MOUNT, MACHINE GUN	1200001	19001	1200001	
1	SPENT BRASS BAG SUPPORT HARDWARE KIT	1220002	19001	1220002	
1	HARDWARE AND ACCESSORIES KIT	1220003	19001	1220003	

PRIC NA	CONTRACT NUMBER	DESIGN ACTIVITY																																																
<table border="1" style="width: 100%; border-collapse: collapse;"> <thead> <tr> <th colspan="4">REVISIONS</th> </tr> <tr> <th style="width: 5%;">LTR</th> <th style="width: 25%;">DESCRIPTION</th> <th style="width: 15%;">DATE (YY-MM-DD)</th> <th style="width: 55%;">APP</th> </tr> </thead> <tbody> <tr><td> </td><td> </td><td> </td><td> </td></tr> <tr><td> </td><td> </td><td> </td><td> </td></tr> <tr><td> </td><td> </td><td> </td><td> </td></tr> <tr><td> </td><td> </td><td> </td><td> </td></tr> <tr><td> </td><td> </td><td> </td><td> </td></tr> <tr><td> </td><td> </td><td> </td><td> </td></tr> <tr><td> </td><td> </td><td> </td><td> </td></tr> <tr><td> </td><td> </td><td> </td><td> </td></tr> <tr><td> </td><td> </td><td> </td><td> </td></tr> <tr><td> </td><td> </td><td> </td><td> </td></tr> </tbody> </table>		REVISIONS				LTR	DESCRIPTION	DATE (YY-MM-DD)	APP																																									CONTRACTOR DRAWN BY DATE (YY-MM-DD) CHECKER ENGINEER DRAWING APPROVAL DESIGN APPROVAL
REVISIONS																																																		
LTR	DESCRIPTION	DATE (YY-MM-DD)	APP																																															
		SIZE CAGE CODE UNIT WT SHEET																																																

FIGURE 200-46. Package content drawing

This sample drawing is informational only and complete to the degree necessary to illustrate a type of drawing. Actual format and drawing shall conform to the textual requirements set forth in this standard.

DOD-STD-00100D(AR)

201.16 Software and Firmware Data. Drawings defining software resident in a firmware device will be prepared as SOFTWARE CONTROL DRAWINGS for the master media and ALTERED ITEM DRAWINGS for the firmware.

201.16.1 Software Control drawing. A software control drawing will describe the characteristics of the executable software and its media which will subsequently be used for programming the firmware. The description will be that of the master, a copy of which will be provided to the manufacturer for use in programming micro-circuits. Bit patterns will not be defined as truth tables but rather supplied as a master in magnetic form.

201.16.1.1 Requirements. The software control drawing shall specify the type of media, i.e., magnetic tape, disc, etc., its identification number and revision level. In addition, its characteristics shall be fully described, such as number of tracks, density, size, etc. Any other information necessary to completely describe the media's characteristics and how it must be used, such as specifications, shall also be included. The repository where the MASTER is stored and maintained shall be shown. The note, "A COPY OF THE MASTER, SUITABLE FOR USE IN LOADING DEVICES Part No., WILL BE FURNISHED UPON REQUEST, TO THE MANUFACTURER BY THE CONTRACTING OFFICER" shall be shown on the drawing. See FIGURE 200-47. Part number shall only be shown as a dash number identifier of the master media in the general notes.

159

NOTES:	
1.	APPLICABLE STANDARDS/SPECIFICATIONS A. DOD-STD-00100D(AR)
2.	THE BIT PATTERNS FOR PROM LOADING ARE CONTAINED ON MAGNETIC TAPE I23XXX6-1, VERSION 02.
3.	THE MAGNETIC TAPE HAS THE FOLLOWING CHARACTERISTICS: A. NUMBER OF TRACKS: 9 B. DENSITY: 1600 BPI C. SIZE: 2400 FEET D. BLOCKING: 1200 E. FORMAT: ASCII
4.	REPOSITORY FOR THE MASTER IS: U.S. ARMY ARMAMENT RESEARCH, DEVELOPMENT AND ENGINEERING CENTER PICATINNY ARSENAL, NJ, 07806-5000
5.	A COPY OF THE MASTER, SUITABLE FOR USE IN LOADING DEVICES I23XXX6, WILL BE FURNISHED UPON REQUEST, TO THE MANUFACTURER BY THE CONTRACTING OFFICER.

SOFTWARE CONTROL DRAWING

NO.	REV.	DATE	BY	CHKD.	APP'D.	DESCRIPTION
1						
2						
3						
4						
5						
6						
7						
8						
9						
10						
11						
12						
13						
14						
15						
16						
17						
18						
19						
20						
21						
22						
23						
24						
25						
26						
27						
28						
29						
30						
31						
32						
33						
34						
35						
36						
37						
38						
39						
40						
41						
42						
43						
44						
45						
46						
47						
48						
49						
50						
51						
52						
53						
54						
55						
56						
57						
58						
59						
60						
61						
62						
63						
64						
65						
66						
67						
68						
69						
70						
71						
72						
73						
74						
75						
76						
77						
78						
79						
80						
81						
82						
83						
84						
85						
86						
87						
88						
89						
90						
91						
92						
93						
94						
95						
96						
97						
98						
99						
100						

FIGURE 200-47. Software control drawing

This sample drawing is informational only and complete to the degree necessary to illustrate a type of drawing. Actual format and drawing shall conform to the textual requirements set forth in this standard.

DOD-STD-00100D(AR)

201.16.2 Firmware drawing. The drawing describing the requirements of a single programmed device will be prepared as an ALTERED ITEM DRAWING in accordance with para 201.4.4. Circuit boards with multiple devices that require programming at that level will be prepared as an assembly drawing. Devices assembled at that level will be supported by appropriate specifications or drawings that specify requirements prior to downloading.

201.16.2.1 Requirements. The firmware drawing shall define the requirements of the device prior to programming either on this drawing or by specification for source control drawing if MILITARY specification item is not available. In addition, the requirements for programming (bit pattern downloading) of the device using Government furnished media and instructions shall be included. The same type of requirements shall be included on drawings for circuit boards with multiple devices programmed at the same time. Notation pertaining to acceptance inspection requirements shall also be included. See FIGURE 200-48.

NOTES:		PART NO. I23XXXX6		
1. APPLICABLE STANDARDS/SPECIFICATIONS: A. DOD-STD-00100D(AR)				
2. MICROCIRCUIT SHALL BE IN ACCORDANCE WITH REQUIREMENTS OF I23XXXX5, EXCEPT FOR PROGRAMMING BY DOWNLOADING BIT PATTERNS CONTAINED ON MAGNETIC MEDIA DESCRIBED ON SOFTWARE CONTROL DWG I23XXXX8.				
3. SPECIFICATION I9200-55XXX APPLIES FOR BIT PATTERN DOWNLOADING AND VERIFICATION.				
4. QUALITY ASSURANCE PROVISIONS (QAP) I23XXXX6 APPLY TO THIS ITEM.				
5. ITEM IDENTIFICATION: APPLY THE FOLLOWING MARKING TO CONTAINER IN ACCORDANCE WITH MIL-STD-130. "I9200-I23XXXX6" MFR- <input type="text"/> <input type="text"/> / MANUFACTURER'S / CAGE CODE				
ALTERED ITEM DRAWING PART NO. I23XXXX6				
REVISIONS	DATE	BY	DESCRIPTION	DATE
DRAWN BY: _____				DATE: _____
CHECKED BY: _____				DATE: _____
APPROVED BY: _____				DATE: _____
MATERIAL SPECIFICATIONS: _____				DATE: _____
MATERIAL QUANTITIES: _____				DATE: _____
MATERIAL WEIGHTS: _____				DATE: _____
MATERIAL DIMENSIONS: _____				DATE: _____
MATERIAL TOLERANCES: _____				DATE: _____
MATERIAL FINISHES: _____				DATE: _____
MATERIAL TREATMENTS: _____				DATE: _____
MATERIAL MARKINGS: _____				DATE: _____
MATERIAL IDENTIFICATION: _____				DATE: _____
MATERIAL STORAGE: _____				DATE: _____
MATERIAL HANDLING: _____				DATE: _____
MATERIAL DISPOSAL: _____				DATE: _____
MATERIAL REWORK: _____				DATE: _____
MATERIAL REUSE: _____				DATE: _____
MATERIAL REPAIR: _____				DATE: _____
MATERIAL RECYCLING: _____				DATE: _____
MATERIAL WASTE: _____				DATE: _____
MATERIAL SAFETY: _____				DATE: _____
MATERIAL HAZARD: _____				DATE: _____
MATERIAL TOXICITY: _____				DATE: _____
MATERIAL CORROSIVITY: _____				DATE: _____
MATERIAL FLAMMABILITY: _____				DATE: _____
MATERIAL EXPLOSION: _____				DATE: _____
MATERIAL REACTIVITY: _____				DATE: _____
MATERIAL COMPATIBILITY: _____				DATE: _____
MATERIAL STABILITY: _____				DATE: _____
MATERIAL DURABILITY: _____				DATE: _____
MATERIAL RELIABILITY: _____				DATE: _____
MATERIAL PERFORMANCE: _____				DATE: _____
MATERIAL EFFICIENCY: _____				DATE: _____
MATERIAL COST: _____				DATE: _____
MATERIAL AVAILABILITY: _____				DATE: _____
MATERIAL SUPPORT: _____				DATE: _____
MATERIAL TRAINING: _____				DATE: _____
MATERIAL DOCUMENTATION: _____				DATE: _____
MATERIAL RECORDS: _____				DATE: _____
MATERIAL AUDIT: _____				DATE: _____
MATERIAL COMPLIANCE: _____				DATE: _____
MATERIAL LEGAL: _____				DATE: _____
MATERIAL ETHICS: _____				DATE: _____
MATERIAL INTEGRITY: _____				DATE: _____
MATERIAL HONESTY: _____				DATE: _____
MATERIAL FAITHFULNESS: _____				DATE: _____
MATERIAL COURTESY: _____				DATE: _____
MATERIAL RESPECT: _____				DATE: _____
MATERIAL TOLERANCE: _____				DATE: _____
MATERIAL PATIENCE: _____				DATE: _____
MATERIAL KINDNESS: _____				DATE: _____
MATERIAL GENTLENESS: _____				DATE: _____
MATERIAL MERCY: _____				DATE: _____
MATERIAL GRACE: _____				DATE: _____
MATERIAL PEACE: _____				DATE: _____
MATERIAL JOY: _____				DATE: _____
MATERIAL LOVE: _____				DATE: _____
MATERIAL HOPE: _____				DATE: _____
MATERIAL FAITH: _____				DATE: _____
MATERIAL CHARITY: _____				DATE: _____
MATERIAL WISDOM: _____				DATE: _____
MATERIAL UNDERSTANDING: _____				DATE: _____
MATERIAL KINDNESS: _____				DATE: _____
MATERIAL GENTLENESS: _____				DATE: _____
MATERIAL MERCY: _____				DATE: _____
MATERIAL GRACE: _____				DATE: _____
MATERIAL PEACE: _____				DATE: _____
MATERIAL JOY: _____				DATE: _____
MATERIAL LOVE: _____				DATE: _____
MATERIAL HOPE: _____				DATE: _____
MATERIAL FAITH: _____				DATE: _____
MATERIAL CHARITY: _____				DATE: _____
MATERIAL WISDOM: _____				DATE: _____
MATERIAL UNDERSTANDING: _____				DATE: _____
MATERIAL KINDNESS: _____				DATE: _____
MATERIAL GENTLENESS: _____				DATE: _____
MATERIAL MERCY: _____				DATE: _____
MATERIAL GRACE: _____				DATE: _____
MATERIAL PEACE: _____				DATE: _____
MATERIAL JOY: _____				DATE: _____
MATERIAL LOVE: _____				DATE: _____
MATERIAL HOPE: _____				DATE: _____
MATERIAL FAITH: _____				DATE: _____
MATERIAL CHARITY: _____				DATE: _____
MATERIAL WISDOM: _____				DATE: _____
MATERIAL UNDERSTANDING: _____				DATE: _____
MATERIAL KINDNESS: _____				DATE: _____
MATERIAL GENTLENESS: _____				DATE: _____
MATERIAL MERCY: _____				DATE: _____
MATERIAL GRACE: _____				DATE: _____
MATERIAL PEACE: _____				DATE: _____
MATERIAL JOY: _____				DATE: _____
MATERIAL LOVE: _____				DATE: _____
MATERIAL HOPE: _____				DATE: _____
MATERIAL FAITH: _____				DATE: _____
MATERIAL CHARITY: _____				DATE: _____

FIGURE 200-48. Altered item drawing (Firmware)

This sample drawing is informational only and complete to the degree necessary to illustrate a type of drawing. Actual format and drawing shall conform to the textual requirements set forth in this standard.

DOD-STD-00100D(AR)

**CHAPTER 300
DRAWING TITLES**

300 General. This chapter establishes procedures for creating titles for engineering drawings and for parts detailed thereon.

301 Definitions. Definitions for words and terms marked with an asterisk (*) are located in Chapter 700.

301.1 Drawing title. The drawing title shall be the name by which the part or item will be known and shall consist of a basic name, government type designator, if applicable, and sufficient modifiers to differentiate like items in the same major assembly. Only drawing titles shall be in the title block. References to next assembly/major item shall not be shown unless part of the drawing title.

301.2 Approved item name. An approved item name is a name approved by the Directorate of Cataloging, Defense Logistics Services Center and published in the Cataloging Handbook H6, Federal Item Name Directory for Supply Cataloging.

301.3 Type designation. Type designators are a combination of letters and/or numbers assigned by the Government to identify an item(s) in accordance with MIL-STD-1464.

301.4 Assembly. The term ASSEMBLY* when used as a part of the drawing title will conform to the definition for the terms contained in Chapter 700 and meet the requirements of Federal Cataloging Handbook H6 series.

302 Procedures for creating drawing titles. Titles for drawings requiring modifiers shall be in two parts. The first part shall be the name. The second part shall consist of those additional modifiers and government type designators necessary to complete the identification of the item. The drawing title shall be shown in upper-case letters.

302.1 General rules. The following rules apply to all drawing titles:

a. No abbreviations of any portion of the name (first part of the title) shall be made, except those necessarily used trademarked names and the words ASSEMBLY (ASSY), SUBASSEMBLY (SUBASSY), or INSTALLATION (INSTL). Abbreviations may be used in the second part of the title; however, they shall conform to those abbreviations listed in MIL-STD-12. In general, the use of abbreviations shall be avoided.

b. Titles of detail parts shall be consistent with the titles of their next assembly drawings, except where interchangeability of such detail parts between assemblies makes consistency impractical or is prohibited by the Government Design Activity, or when such use limits application.

c. When a drawing is prepared to replace an existing drawing with a different number and the title of the drawing being replaced is in accordance with instructions contained herein, the same title shall be used. When the title of the drawing being replaced is not in accordance with these instructions, a new drawing title shall be developed.

DOD-STD-00100D(AR)

d. A drawing title shall be as brief and simple as possible, shall describe the item and shall distinguish between similar items.

e. The names of parts* detailed on a drawing shall consist of a noun or noun phrase. Modifiers may be used to distinguish between parts on the same drawing.

f. For words with dual or multiple definitions, the Military definitions as published in the Federal Item Name Dictionary for Supply Cataloging, Section A, Cataloging Handbook H6-1 shall have precedence.

g. Multi-sheet drawings shall have the exact same titles on all sheets.

302.2 First part of title. The first part of the title shall be one of the following in order of preference.

a. An approved item name selected from the Federal Item Name Directory for Supply Cataloging, Section A, Cataloging Handbook H6, whose definition describes the item (e.g. "PIN, STRAIGHT, HEADED", "SPRING, HELICAL, COMPRESSION", ENGINE, GASOLINE, RIB, WING SECTION, INNER).

b. Where the procedure outlined in paragraph 302.2a does not provide a suitable name, the following procedures shall be followed:

(1) The basic name shall be a noun or noun phrase. Modifiers shall be included as required by paragraph 302.2c.

(2) This noun or noun phrase shall establish a basic concept of an item. A compound noun or noun phrase shall be used only when a single noun is not adequate to establish a basic concept of an item. Cataloging Handbook H6 shall be used as a guide in establishing the noun or noun phrase.

(3) A noun or noun phrase such as "casting", "forging", "weldment", etc., shall not be used in the title of a drawing for a finished part, even if shown on a separate sheet. "Casting" etc., may be used in the title of a drawing for a casting that is subject to further fabrication as described on another separate drawing. In lieu of such a name, a noun or noun phrase shall be assigned which indicates what the item is or what it does, e.g., "BRACKET" in the title, "BRACKET, SUPPORT MIXING VALVE".

(4) The noun or noun phrase shall be used in singular form, except as follows:

(a) Where the only form of the noun is plural, e.g., "TONGS".

(b) Where multiple single items appear out on the same drawing, e.g., "FUSES", "CONNECTORS", "FASTENERS".

(c) Where the nature of the item requires the plural form, e.g., "CLIMBERS", "GLOVES".

DOD-STD-00100D(AR)

(5) The word "ASSEMBLY" shall be used in names selected from Cataloging Handbook H6 exactly as published therein, e.g., "CABLE ASSEMBLY, SPECIAL PURPOSE, ELECTRICAL". When no applicable name appears in Cataloging Handbook H6 the word "ASSEMBLY" shall be used as the last word of the noun phrase, e.g., "INTAKE-MANIFOLD ASSEMBLY, GASOLINE ENGINE".

(6) An ambiguous noun, or one which designates several classes of items, shall not be used alone, but shall be used as part of a noun phrase.

Example:

Acceptable

SLIDE RULE
SOLDERING IRON

Unacceptable

RULE, SLIDE
IRON, SOLDERING

NOTE: One of the most difficult tasks in naming any item is the determination as to when a noun should be qualified as being ambiguous. The general rule quoted above is amplified to some extent in the succeeding paragraph. When a noun does not expressly fit under any of these rules, a guide in determining whether the selected noun is or is not ambiguous, is to refer to Cataloging Handbook H6 to see if it is listed. For example, if there is a question on the noun "plate", a review of the index will reveal many item names with the noun "plate" used, indicating that the noun is not considered as being ambiguous.

(7) A trade-marked or copyrighted name shall not be used as the noun or noun phrase except where the technical name is extremely difficult, e.g., "FREON 12" rather than "DICHLORODIFLUORMETHANE" or where no other name is available.

(8) When an item is not a container or material, but its name involves the use of a noun which ordinarily designates a container or material, a noun phrase shall be used as the basic name.

Examples:

Acceptable

JUNCTION BOX
CABLE DRUM
SOLDERING IRON

Unacceptable

BOX, JUNCTION
DRUM, CABLE
IRON, SOLDERING

DOD-STD-00100D(AR)

(9) The following words shall never be used alone but may be the last word of a noun phrase:

Apparatus	Equipment	Plant
Assembly	Group	Ship
Assortment	Installation	Subassembly
Attachment	Kit	Tackle
Compound	Machine	Tool
Device	Mechanism	Unit
Element	Outfit	Vehicle

EXCEPTION: In certain instances, some of the listed words may be used as the first word in a basic noun phrase, e.g., "MACHINE SHOP" or "TOOL KIT".

c. When the noun or noun phrase represents an item to which types, grades, varieties, etc., are applicable, the remainder of the first part of the title shall consist of one or more modifiers.

(1) A modifier may be a single word or a qualifying phrase. The first modifier shall serve to narrow the area of concept established by the basic name and succeeding modifiers must continue a narrowing of item concept by expressing a different type of characteristic. A word directly qualifying a modifying word shall precede the word it qualifies, thereby forming a modifying phrase, e.g., "BRACKET, UTILITY LIGHT". It is to be noted the word "UTILITY" qualifies the word "LIGHT" and precedes it in the modifying phrase.

(2) A modifier shall be separated from the noun or noun phrase by a comma and from any preceding modifier by a comma. The hyphen in compound words and the dash in type designators are not punctuation marks.

(3) The conjunction "or" and the preposition "for" shall not be used.

(4) The first part of the title shall be separated from the second part of the title by a dash.

302.3 Second part of title. The second part of the title shall consist of such additional modifiers, modifying phrases, or government type designators as are required. Modifiers indicating what an item is (its shape, structure, or form) or what the item does (its function) are preferable to modifiers indicating the application (what it is used for) or location of the item (where it is used) (e.g., "SPRING, HELICAL COMPRESSION - RECOIL ADAPTER").

First Part of Title

Second Part of Title

a. When two or more drawings are similar, and the parts* detailed on them perform the same general function, they shall be distinguished by additional modifiers indicating their location, relative position, forms, dimensions, etc., for example: "RIB, WING SECTION, INNER-STATION 276".

b. Non-part drawings (e.g., schematic, wiring diagrams, etc.) may include the drawing type as the second part of the drawing title (e.g., AMPLIFIER, FIRE CONTROL - SCHEMATIC DIAGRAM).

DOD-STD-00100D(AR)

303 Disclosure of security categories. No word(s), symbol(s), nor any of their possible combinations which would disclose information in any of the established security categories, shall be used in drawing titles. See Appendix B.

304 Titles for kit drawings. Titles shall be determined from Cataloging Handbook H-6. Typical examples are:

- a. Modification kit: "MODIFICATION KIT, RIFLE RACKS MOUNTING."
- b. Accessory kit: "HEATER KIT, PERSONNEL CAB."
- c. Conversion kit: "CONVERSION KIT, SEMITRAILER, VAN, MBOX."

165

DOD-STD-00100D(AR)

THIS PAGE LEFT BLANK INTENTIONALLY

991

DOD-STD-00100D(AR)

**CHAPTER 400
NUMBERING, CODING AND IDENTIFICATION**

400 General. This chapter establishes numbering, coding and identification procedures for engineering drawings, associated lists and documents referenced thereon. It also provides identification direction for parts, materials, processes and treatments specified on these engineering drawings and associated lists.

401 Definitions. Definitions for words and terms marked with an asterisk (*) are located in Chapter 700.

401.1 Referenced documents. Referenced documents as used in this chapter are design activity standards*, drawings, specifications, pamphlets or other documents referenced on drawings or lists.

401.2 Contractor and Government Entity Code (CAGE Code). CAGE (code identification) number is a five-digit alpha-numeric code applicable to all activities which have produced or are producing items used by the Federal Government. It also applies to Government activities which control design, or are responsible for the development of certain specifications, drawings, or standards which control the design of items. These numbers are assigned in conformance with Cataloging Handbook H4/H8, CAGE Code. Activities not assigned a CAGE Code shall request such identification in conformance with Cataloging Handbook H4/H8. Organizations which neither manufacture nor control design such as dealers, agents, or vendors of items produced by others are not included in the H4/H8. CAGE Code shall be entered in the appropriate block of the engineering drawing or associated list format.

401.3 Document identification number. The document identification number consists of numbers of combinations of letters, numbers, and dashes. This number is assigned to a document, in addition to the title and CAGE Code, for identification purposes.

401.4 Drawing number. The drawing number consists of letters, numbers or combination of letters and numbers, which may or may not be separated by dashes. The number is assigned to a particular drawing for identification purposes by the design activity. The drawing number shall be assigned from a block of numbers provided by the Government Design Activity. Package content, all kit drawings and vehicle top assemblies may require selected identification numbers as determined by the Government Design Activity. (See paragraph 402.5).

401.5 Part number. Part numbers consist of letters, numbers or combinations of letters and numbers, which may or may not be separated by dashes that are assigned to uniquely identify a specific item. The part number shall be or shall include the design activity drawing number, and may include a dash number suffix (if applicable). (See paragraph 402.6)

DOD-STD-00100D(AR)

401.6 Find number. A find number may be assigned to an item* (part, assembly, etc.) on the field of a drawing for purposes of cross-referencing to items on a parts list; and as locators in lieu of using the item part number. The parts, assemblies, etc., so marked have other identifying numbers for purposes of procurement and marking which are cross-referenced to the find numbers in the integral parts lists, or in a table on the drawing. Reference designations in accordance with IEEE Stds 200 and 315 may be used as "find numbers". (See paragraphs 603.2.9 and 201.1.2). Find numbers will be considered for use only on drawings of complicated electronic devices and mechanical assemblies, tools, gages, or fixtures. Find numbers shall be cross-referenced to part numbers in a table, located preferably above the title block (See APPENDIX A-9) or as directed by Government Design Activity, on the drawing. Prior authorization by the Government Design Activity is required. Find number system with a separate parts list is not permissible.

402 Identification requirements. All drawings and associated lists shall be assigned identification in conformance with this chapter.

402.1 New drawings and associated lists. New drawings and associated lists shall be assigned a CAGE Code in accordance with paragraphs 401.2, 402.4; drawing number in accordance with paragraphs 401.4, 402.5; and part numbers in accordance with paragraphs 401.5, 402.6, 402.10.

402.2 Existing drawings and associated lists. Existing drawings and associated lists which do not contain a CAGE Code shall have one assigned in accordance with paragraph 401.2 and placed as near as possible to the drawing or associated list number. The CAGE Code shall be preceded by the phrase "CAGE CODE".

402.3 Referenced documents. All documents other than Government or non-government specifications and standards* referenced on drawings shall have a document identification number, and a CAGE Code. These numbers shall be placed in a conspicuous location on the document. The contractor design activity is responsible for assigning or obtaining document numbers and the CAGE Code for documents used with drawings. Technical orders, pamphlets and recordings are not considered referenced documents.

402.4 Contractor and Government Entity Code for Manufacturers. Unless otherwise specified, the CAGE Code shall always be the CAGE Code of the design activity whose drawing number is assigned to the drawing and shall be entered on the drawing in the appropriate block, as shown in Figure 400-1.

402.5 Drawing number. The drawing number shall not exceed 15 characters. These characters may include numbers, letters, and dashes with the following limitations: (See paragraph 402.6).

a. Letters "I", "O", "Q", "S", "X", and "Z" shall not be used; however, letters "S" and "Z" may be used only if they are a part of the existing drawing numbering system. They shall not be used in the development of new drawing numbering systems. Letters shall be upper case (capital letters).

b. Number shall be arabic numerals. Fractional, decimal and Roman numerals shall not be used.

169

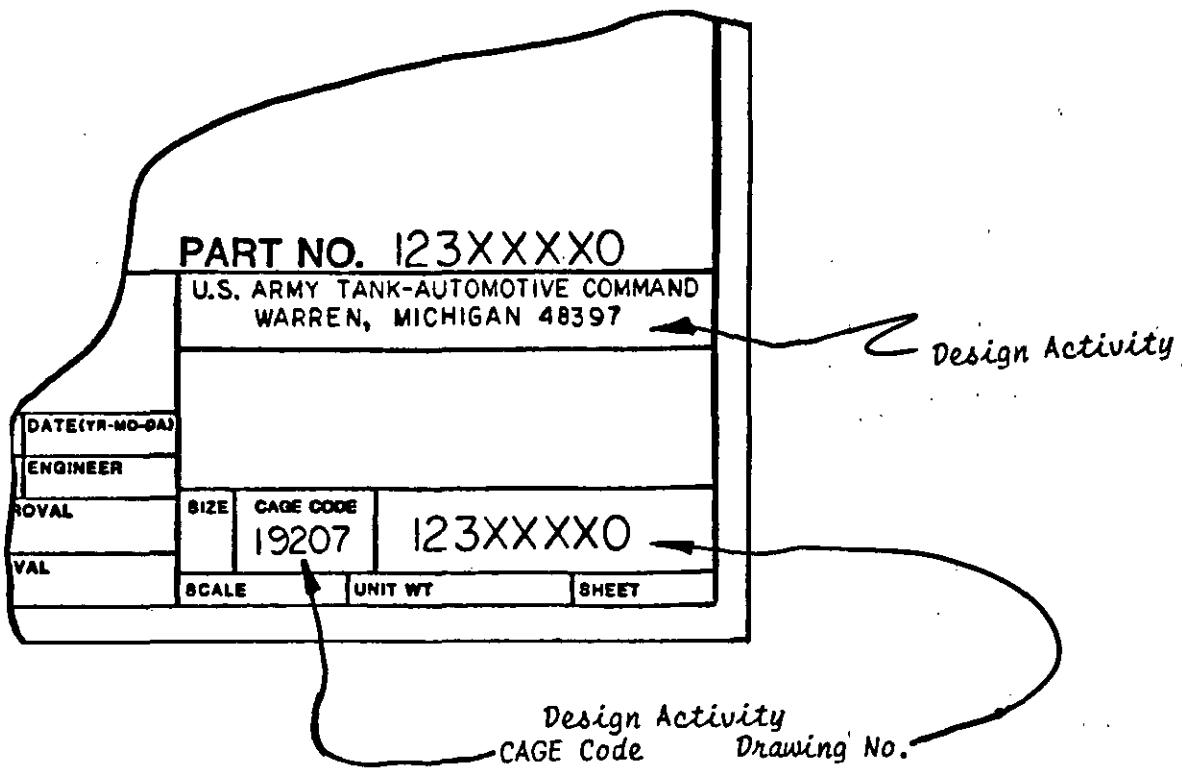

FIGURE 400-1. Example of CAGE Code, Drawing No., Design Activity Relationship as originally specified

DOD-STD-00100D(AR)

- c. Blank spaces are not permitted.
- d. Symbols such as: parenthesis (), asterisks *, virgule /, degree , plus +, minus -, shall not be used, except when referencing the Government or non-government standardization document whose identification contains such a symbol.
- e. The CAGE Code, drawing format size letter, and drawing revision letter (see paragraphs 503.2 and 602.3) are not considered part of the drawing number or part number.
- f. A system based on a significant numbering system or a sequentially assigned non-significant numbering system designed to preclude duplication is acceptable.

402.6 Part numbers. Part numbers shall not exceed 15 characters. This number shall be or shall include the drawing number on which the item is described. Where more than one item is described on a drawing, unique identification shall be provided by the addition of a suffixed dash number, with the following limitations: (For bulk materials see 402.16.4).

- a. The total length of the part number including the suffix shall not exceed 15 characters.
- b. Suffixed dash numbers (-1, -2, -3, etc.) may be used on the following type of drawings:
 - (1) Multi-detail drawings.
 - (2) Tabulated detail drawings.
 - (3) Detail assembly drawings.
 - (4) Tabulated assembly drawings.
 - (5) Inseparable assembly drawings.
- c. Suffixed numbers shall not be used where only one item is described on a drawing.
- d. Suffixed part numbers shall not be used for items previously identified by their own drawing, Military Standard/Specification number, etc.
- e. Suffixed part numbers shall not be used on "Separable Assembly Drawings" where individual parts/subassemblies and Military Standards/Specifications are identified by their respective part number.
- f. Part numbers shall not include the drawing revision. (See paragraph 402.5.e).

DOD-STD-00100D(AR)

g. Items already identified by part number shall not be reidentified with a dash suffix, if drawing is changed to incorporate additional items by tabulation. The additional items shall be identified with a dash suffix.

h. Part number shall not be specified on documents that do not define an item. Examples follow:

- (1) Schematics (electrical/mechanical)
- (2) Wiring diagrams
- (3) Logic diagrams
- (4) Interface drawings
- (5) Camouflage drawings
- (6) Installation drawings
- (7) Elevation drawings
- (8) Connection diagrams
- (9) Printed Wiring Master pattern drawing, etc.

NOTE: Contractor-manufacturer part and drawing numbering systems.

Contractors and manufacturers are encouraged to forward to the Commander Defense Logistics Services Center, ATTN: DLSC-CTC, Federal Center, Battle Creek, Michigan 49016, an explanation of their part and drawing numbering systems to be included in Cataloging Handbook H7, Manufacturers Part and Drawing Numbering Systems for use in the Federal Cataloging System.

171
402.7 Records. A complete and accurate record of drawing numbers shall be maintained by the activity allocating or assigning the numbers.

402.8 Associated lists. Associated lists and documents shall be assigned the same identifying numbers (part numbers) as the assembly drawing to which it pertains. This identifier shall be prefixed by the letters "PL", "QAP", "PS", etc.

402.9 Transferring design responsibility to another activity. When the design responsibility for engineering drawings is transferred from one design activity to another, the drawing number(s) and part number(s) shall be transferred to the new design activity for administration. The new assignee shall add his CAGE Code on the drawing by revision action to identify change in design responsibility. In no case will the original drawing identity be changed or relocated to indicate a new CAGE Code. In addition, the CAGE Code of the original design activity specified in the item identification marking requirement shall not be changed. (See paragraph 108.1.1). The new design activity shall be identified in a manner shown in FIGURE 400-2.

402.9.1 Source control drawing. When the engineering drawing is source control, the name and address of the cognizant design activity in the note "ONLY THE ITEM DESCRIBED" etc., shall also be revised to reflect the transfer of design responsibility.

DOD-STD-00100D(AR)

CURRENT DESIGN ACTIVITY CAGE CODE 19200 U.S. ARMY ARMAMENT RESEARCH, DEVELOPMENT AND ENGINEERING CENTER PICATINNY ARSENAL, NEW JERSEY 07806-8000		
PART NO. 123XXXXX		
DESIGN ACTIVITY U.S. ARMY TANK-AUTOMOTIVE COMMAND WARREN, MICHIGAN 48397-5000		
SIZE	CAGE CODE	123XXXXX
SCALE	UNIT WT	SHEET

Current Design Activity Identity and CAGE Code

Original Design Activity CAGE Code, Part No., and Drawing No.

FIGURE 400-2. Example of Drawing Notation when Design Responsibility is Transferred

402.9.2 Maintaining design activities identities. When drawings are redrawn, the original design activity CAGE Code, Drawing and Part numbers shall be shown in their applicable locations as on the original documentation. The current and original design activity identity shall be as shown in FIGURE 400-3a.

CURRENT DESIGN ACTIVITY CAGE CODE 19200 U.S. ARMY ARMAMENT RESEARCH, DEVELOPMENT AND ENGINEERING CENTER PICATINNY ARSENAL, NEW JERSEY 07806-8000		
PART NO. 123XXXXX		
DESIGN ACTIVITY U.S. ARMY TANK-AUTOMOTIVE COMMAND WARREN, MICHIGAN 48397		
SIZE	FSCM NO.	123XXXXX
SCALE	UNIT WT	SHEET

Current Design Activity Identity and CAGE Code

Original Design Activity FSCM No., Part No., and Drawing No.

FIGURE 400-3a. Example of Drawing Entries when Redrawn after Design Responsibility was Transferred.

DOD-STD-00100D(AR)

402.9.3 Drawings with "00000" CAGE Code (CODE IDENT). Drawings having a CAGE Code (CODE IDENT) of "00000" which is associated with the original design activity drawing number shall be changed to reflect the current CAGE Code of that original design activity. See FIGURES 400-3b and 400-3c.

1.40	1.12	.62	.400	.14	1.125			10921754-5
CODE IDENT. NO. 00000								
PART NO. <i>SEE TAB :</i>								
SPECIFIED INCHES ON ANGLES	ORIGINAL DATE OF DRAWING	JAN. 2, 1962		PIN, QUICK RELEASE				ORDNANCE CORPS DEPT OF THE ARMY DETROIT ARSENAL
	DRAFTSMAN	CHECKER						
TRACER	ENGINEER							
DATE SUBMITTED								
	APPROVED BY ORDER OF THE CHIEF OF ORDNANCE	 ONI CORPS		SCALE	2/1	UNW	WT	DWG SIZE C 10921754 SHEET 1 OF 1

FIGURE 400-3b. Example of "00000" CAGE Code (CODE IDENT) prior to change

DOD-STD-00100D(AR)

1.40	1.12	.62	.400	.14	1.125			10921754-5
(H) (G)								CURRENT DESIGN ACTIVITY CAGE CODE 19200 U.S. ARMY ARMAMENT RESEARCH, DEVELOPMENT AND ENGINEERING CENTER PICATINNY ARSENAL, NEW JERSEY 07806-5000
ORIGINAL CODE IDENT. NO. 00000 19207								(F)
PART NO. SEE TAB:								
SPECIFIED IN INCHES OR ON ANGLES	ORIGINAL DATE OF DRAWING JAN. 2, 1962	PIN, QUICK RELEASE				ORDNANCE CORPS DEPT OF THE ARMY DETROIT ARSENAL		
DRAFTSMAN TRACER CORR. BY SUBMITTED	CHECKER ENGR.	DWG SIZE C				10921754 SHEET 1 OF 1		
APPROVED BY ORDER OF THE CHIEF OF ORDNANCE <i>Ralph E. [Signature]</i>	ORDNANCE CORPS							

FIGURE 400-3c. Example of change to the current CAGE Code of the original design activity

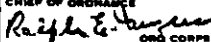
174

DOD-STD-00100D(AR)

402.10 Item identification and part numbering. Each item*, e.g., detail part, assembly, etc., shall be identified as follows:

a. An item* covered by an approved standard and used without alteration or selection shall be identified by the standard part number (such as MS number for Military Sheet form standards).

b. An item* covered by an approved government specification containing a part identification system and used without alteration shall be identified by that specification part identification.

c. All other items* shall be identified by a part number and CAGE Code on a drawing, except for a deviation granted to construction drawings in paragraph 402.11. (See Note 1.)

d. Government Design Activities* using items other than their design without alteration or selection shall identify such items by the other Government Design Activity part number and CAGE Code.

e. Items* referenced above which are altered or selected shall be identified by a part number established (see paragraph 402.14, Condition 4) by the using design activity drawing which depicts requirements for such alteration or selection. The using design activity drawing shall also contain the original item identification part number which was applicable prior to the alteration or selection. (See paragraphs 201.4.4 and 201.4.5).

NOTE 1: Specification control drawing numbers (with any applicable dash numbers, if tabulated) is the part number. The part number shall be used to physically identify the part without obliterating the original vendor(s) part number. (See paragraphs 201.4.2 and 402.10.d).

NOTE 2: Source control drawing numbers are part identification numbers. When more than one vendor is listed on a source control drawing for items that are repairable and the repair parts are identified and not interchangeable between the vendors, each vendor's item shall be assigned a dash number of the source control drawing number.

402.10.1 Re-identification. When items are identified by more than fifteen characters or do not meet the other requirements of paragraphs 402.5 and 402.6 and a design activity has no control over this assignment, it may assign a design activity control number to the item in order to meet the identification requirements of paragraphs 402.5 and 402.6.

DOD-STD-00100D(AR)

402.11 Identification on drawings. Items* shall be identified on the field of the drawing either by showing the identifying part numbers (paragraph 402.10) or find numbers (paragraph 401.6) cross-referenced to the identifying part numbers appearing on an integral parts list except that on a monodetail drawing the item need not be identified on the field of the drawing. When several items* are detailed on a single drawing, such as tabulated, multi-detail, detail assembly or installation drawing, (paragraphs 201.2.2, 201.2.3, 201.3.1 and 201.5) each item shall be assigned a separate identification in accordance with paragraph 402.6. The complete part number shall be shown on drawings and lists. On construction drawings (paragraph 201.8) each item shall be identified to permit construction as designed. The identification need not include an identifying part number or a find number as specified herein unless stock storage and issue is intended.

a. Part/Assembly Identification. The format identification on assembly and installation drawings shall be Quantity, dash, Nomenclature, dash, CAGE Code (if applicable) and Part Number. Parts shall be identified on the field of the drawing as follows:

(1) Quantity. When quantity is one, no entry shall be made. For bulk material "AR" for "AS REQUIRED" is acceptable. (See paragraph 402.16.4).

(2) Nomenclature. The nomenclature shall be abbreviated to the basic noun or basic noun phrase of title exactly as shown on its own drawing. It shall not be shown in plural form unless the item drawing title is such.

i.e. "2-SPRING-7265329" shall not be specified as
"2-SPRINGS-7265329"

and

"BOOTS-MS3109-03" shall not be specified as
"BOOT-MS3109-03"

(3) CAGE Code. If applicable, in accordance with paragraph 402.12.

DOD-STD-00100D(AR)

(4) Part Number. The complete part number shall be entered as it appears on its drawing (including dash suffix). The part number shall not contain the drawing size or revision level.

EXAMPLES:

"SPRING-7267035"

"2-PIN-505509"
(SHOWN ON DRAWING 1234XXXI)

"GEAR ASSY-12206391-I"

"BRACKET-19200-997XXXX"

"PIN-MSI7985-408"

b. Items completely defined in a Specification (other than Bulk Material). When an item has all its physical and functional characteristics completely defined in a specification, identification shall be in accordance with the following:

(1) When a specification has a part identification numbering system, that number, if within 15 characters, shall be used as the part number. The specification (Detail specification, if applicable) shall be specified in the general notes.

EXAMPLES: (2) IN ACCORDANCE WITH MIL-R-10509" (In general notes)

'6 - RESISTOR - RN60C2432F (2)" (In field of drawing)

(3) IN ACCORDANCE WITH MIL-S-19500/260" (In general notes)

'6 - SEMICONDUCTOR - JAN IN1202 (3)" (In field of drawing)

DOD-STD-00100D(AR)

(2) When a specification does not have a part identification numbering system, the specification with all necessary data, i.e., form, grade, class, type etc., shall be specified in the general notes.

EXAMPLES: $\text{\textcircled{4}}$ IN ACCORDANCE WITH WW-C-440, TYPE I, GRADE B, SIZE 1/2."
(In general notes)

"3-CLAMPS $\text{\textcircled{4}}$ " (In field of drawing)

If the descriptive requirements are lengthy and result in a number exceeding 15 characters, a detail drawing shall be prepared to define the specification item and establish an identification number for the item. For example, when SPEC V-F-106 for Interlocking Slide Fasteners applies, data necessary to define the item could consist of as many as 32 different requirements; therefore, preparation of a separate detail drawing would be required.

402.11.1 Specification control and source control drawings. When specification control or source control drawings are used (paragraphs 201.4.2 and 201.4.3), and it is necessary to refer to the articles depicted thereon on the next assembly or other applicable drawing or list, reference shall be made by specification or source control government part number on face of drawing and in the part or identifying number column of the assembly parts lists.

402.11.2 Parenthetical identifier. Parenthetical in-house identifying numbers shall not be used. The individual parts shown on Detail Assembly and Inseparable Assembly drawings shall be identified by the part number followed by a dash number beginning with "-1", unless the part is a tabulated part; then the succeeding dash number will be used. See FIGURE 200-9.

402.12 CAGE Code and part numbering.

a. Part numbers identifying items or assembly drawings shall be preceded by the CAGE Code when the following occur: (This applies to callouts in the field of the drawing as well as callouts in the general notes.)

(1) When the original CAGE Code for the item identified (callout) is not common to the original CAGE Code of the containing assembly drawing.
EXAMPLE: A part number issued by 19200 and called out on original design activity of 19207 would be "BRACKET-19200-997XXXX".

(2) Part number callouts for SAE and GM standard hardware (if authorized by the Government Design Activity) require the respective CAGE Code to precede the part number callout unless a condition cited in paragraph 402.12b(1) applies.

b. Part numbers identifying items on assembly drawings shall not be preceded by the CAGE Code when the following applies:

(1) When the part is a standard or specification item, and the documentation is listed in the Department of Defense Index of Specifications and Standards (DODISS), or in a recognized non-government standardization document.

DOD-STD-00100D(AR)

(2) Also when the original CAGE Code for the item identified (callout) is common to the original CAGE Code of the containing assembly drawing. See FIGURE A-10 in APPENDIX A.

402.13 Numbering of related parts. Numbers to identify special relationships between parts shall be assigned as follows:

402.13.1 Matched part designation. Parts which must be mated and for which replacement as a matched set or pair is essential, shall be assigned a single number to designate each matched set or pair. Component parts detailed on matched set drawings, in lieu of separate detail drawings, shall be identified in accordance with paragraph 402.11. For serialized number application to the item, see paragraph 108.1.2.

402.13.2 Symmetrically opposite parts*. Symmetrically opposite parts, if not described by separate drawings, shall be described by separate individual views and identified by the dash number system. Do not specify "SHOWN" and "OPPOSITE".

402.13.3 Inseparable assembly. When two or more pieces are permanently fastened together by welding, riveting, brazing, cementing, bonding, etc., to form an inseparable assembly, the assembly shall be assigned an identifying number. The individual pieces shall be assigned part numbers as described in paragraph 402.10 or dash number system in paragraph 402.11.

402.14 Change requiring new identification. Items shall be assigned new design activity numbers different from the original identifying numbers under the following conditions:

a. A new drawing number or part number as described in paragraph 402.10 shall be assigned when a part of assembly is changed in such manner that any of the following conditions occur:

179
Condition 1. Performance or durability is affected to such an extent that superseded items must be discarded for reasons of safety or malfunctioning.

Condition 2. Parts, subassemblies, or complete articles are changed to such an extent that the superseded and superseding items are not functionally or physically interchangeable.

Condition 3. When superseded parts are limited to use in specific articles or models of articles and the superseding parts are not so limited to use.

Condition 4. When an item has been altered or selected (see paragraphs 201.4.4 and 201.4.5).

Condition 5. When interchangeable* repairable* assemblies contain a non-interchangeable part, its next assembly, and all the progressively higher assemblies shall be changed up to and including the assembly where interchangeability is reestablished.

b. When an item* is changed in such a way that necessitates a corresponding change to an operational, self-test or maintenance test computer program, the part number identification of the item and its next assembly and all progressively higher assemblies shall be changed up to and including the assembly where computer programs are affected.

DOD-STD-00100D(AR)

402.15 Changes not requiring new identification. When a part* or assembly is changed in such a manner that conditions of paragraph 402.14 do not occur, the part number shall not be changed. Under no condition shall the number be changed only because a new application is found for an existing part. When an item* has been furnished to the Government, the applicable part number shall not be changed unless conditions in paragraph 402.14 apply. However, when a design activity desires to create a tabulated listing or a standard because of a multiple application of an item, the forementioned need not apply. The superseded drawing shall identify the document which superseded it. The superseding document shall identify the part numbers the items replaced.

402.16 Identification of materials, processes and protective treatment. Materials, processes and protective treatment necessary to meet the design requirements of an item shall be identified on the drawing or parts list by reference to applicable specifications or standards. The applicable type, grade, class, condition, etc., shall be indicated. Revision or amendment symbol of the specification or standard shall not be shown. Additional reference to other equivalent specifications is permitted.

402.16.1 Group identification. Where necessary identification involves several different specifications or standards, these specifications and standards may be grouped into a single document which shall be referenced on the applicable drawings or lists of parts by the single document identification. This document shall be part of the set of drawings. Where several processes or protective treatments are involved and sequence is necessary to meet design requirements, they shall be shown in the order of sequence and be so noted. A single document prepared to group together several specifications and standards shall not be used to circumvent the requirement to prepare a specification. (See paragraph 201.9.1.)

402.16.2 Other identification. When parts, materials, processes and protective treatments are used which cannot be identified adequately in accordance with paragraph 402.16, a separate drawing or specification (if applicable) shall be prepared. The document/part number shall be specified on applicable drawings.

402.16.3 *Formulation identification. Formulation (Chemical constituents of explosives, propellants, pyrotechnics, fillers, etc.) shall be considered and treated as a part and identified in accordance with paragraph 402.6 (part numbering) or 402.10a and 403.10b (specification or standards identifications).

402.16.4 Bulk materials* identification. Bulk materials* shall be identified by a discrete identifier in accordance with paragraph 402.10 or 402.16. Where practicable, the quantity or measurement of material shall be included. Separate engineering drawings shall not be prepared for specific quantities of bulk materials, unless the conditions specified in paragraph 402.16.4a(2)(c) or 402.16.4a(3), (4) or (5) apply..

a. Bulk materials shall be identified on assembly/installation drawings in accordance with the following:

DOD-STD-00100D(AR)

(1) Bulk materials which support a process such as paint, solder, weld rod and adhesives shall be identified in the general note area of the drawing, by specifying all information necessary to completely define the required material (form, grade, class, type, etc., and specification number).

EXAMPLE: (In general notes)

"⑥ IN ACCORDANCE WITH MIL-A-47074, TYPE I, CLASS 2."

(In field of drawing)

"AR-ADHESIVE ⑥"

(2) Bulk materials which have a finite shape such as wire, tubing, cable, chain, tape and hose shall be identified as a component of the assembly/installation as follows:

(a) If the specification defining the material contains an identification numbering system, such a number shall be used for identification along with the specification number.

EXAMPLE: (In general notes)

"⑦ IN ACCORDANCE WITH WIRE - MIL-W-16878."

(In field of drawing)

"WIRE-M16878/IBFE94 LENGTH-AR ⑦"

(b) If the specification defining the material does not contain an identification numbering system, the material shall be identified by specifying all information necessary to completely define the required material."

EXAMPLE: (In general notes)

"⑧ IN ACCORDANCE WITH TAPE MIL-T-43435, TYPE 2, FINISH A, SIZE 2."

(In field of drawing)

"TAPE - LENGTH 12.25 ⑧"

(c) When required to support provisioning requirements, a discrete part number consisting of the drawing number and a dash number may be assigned to identify each size, length and/or quantity of bulk material used in an assembly/installation. Preparation of a separate drawing is preferred.

(d) When practicable, the quantity of the material shall be included with the identification. The abbreviation "AR" (for "as required") is acceptable.

DOD-STD-00100D(AR)

(e) The fifteen character limitation for part numbers imposed in paragraph 402.6 does not apply for bulk material.

(3) Separate drawings shall not be prepared for bulk materials covered by specifications or standards except when required to support provisioning/maintenance requirements, e.g., Package Contents/Kit Drawings.

(4) If an item made from bulk material to a specific size has been designated in the provisioning process for separate stockage, then a separate detail drawing is required.

(5) If a bulk material requires a NSN for provision and does not have a discrete part numbering system, a drawing may be required, such as for chain and attached links and hooks.

402.16.5 Identification of precious metals.

a. Precious metals (gold, silver, platinum, palladium, rhodium, ruthenium, osmium and iridium) shall be identified on the engineering drawing according to type of precious metal and amount in grams.

b. Precious metal identification shall be shown on component and part drawings. Repeat or summarization on assembly drawings is not required. However, for assemblies with parts containing precious metal(s), entry in the PMIC block of the assembly drawing shall be in accordance with Note 4, FIGURE 400-4.

c. The type and amount shall be specified by use of the Precious Metal Indicator Code (PMIC), shown on FIGURE 400-4.

d. The identification of the precious metal location on the item is not required.

e. Precious metal identification shall be shown in applicable block (in title block) citing the PMIC and weight in grams (rounded off to the nearest whole number). See FIGURE A-1 in APPENDIX A.

f. The drawing notation for a part containing 6.8g of silver shall be: "E, 7 GRAMS".

g. If the component part or assembly does not have precious metals, enter code "A" in the PMIC block.

h. If PMIC is not applicable, i.e., installation drawings, interface control, schematic diagrams, non-item, etc., then enter "NA" (for not applicable) in the PMIC block.

DOD-STD-00100D(AR)

CODE	TYPE OF PRECIOUS METAL	CONTENT VALUE
CD	Component Drawing(s) specifies type	Component Drawing(s) specifies content
NA	PMIC is not applicable to drawing	Not Applicable
A	No known Precious Metal	None
B	Item is known to contain Precious Metal(s) but the amount(s) are unknown	Unknown
C	The presence or absence of Precious Metals varies between items of production for same item of supply	Unknown
D	Silver	Equals 15 grams or more
E	Silver	Less than 15 grams
F	Gold	Equals 10 grams or more
G	Gold	Less than 10 grams
H	Platinum	Equals 10 grams or more
I	Platinum	Less than 10 grams
J	Palladium	Equals 5 grams or more
K	Palladium	Less than 5 grams
L	Iridium	Equals 20 grams or more
M	Iridium	Less than 20 grams
N	Rhodium	Equals 15 grams or more
O	Rhodium	Less than 15 grams
P	Osmium	Equals 10 grams or more
Q	Osmium	Less than 10 grams
R	Ruthenium	Equals 10 grams or more
S	Ruthenium	Less than 10 grams
T	Silver-Gold	Combination equals 15 grams or more
U	Silver-Gold	Combination contains less than 15 grams
V	Silver-Platinum Family	Combination equals 15 grams or more
W	Silver-Platinum Family	Combination contains less than 15 grams
X	Silver-Gold-Platinum Family	Combination equals 15 grams or more
Y	Silver-Gold-Platinum Family	Combination contains less than 15 grams
Z	Gold-Platinum Family	Combination equals 10 grams or more
2	Gold-Platinum Family	Combination contains less than 10 grams
3	Determination of Precious Metal content is uneconomical	

See Note 1

See Note 1

FIGURE 400-4. Precious Metals Indicator Code

- 183
- NOTES: 1. Platinum Family includes Platinum, Palladium, Iridium, Rhodium, Osmium, and Ruthenium.
2. When the type of precious metal is known but the content value is unknown, use the "Less than 10 grams" code for that metal (i.e., for Gold, use Code "G"; for Silver, use Code "E", etc.)
3. When the type and amount of precious metal is unknown, use Code "B".
4. For Assembly drawings with components containing precious metal, use CD for PMIC.

DOD-STD-00100D(AR)

402.16.6 Nuclear hardness critical items and processes.

402.16.6.1 Items. Where survivability considerations are applied and nuclear Hardness Critical Items (HCI) are identified, all applicable drawings shall identify individual HCIs on the drawing, and on the parts list (see paragraph 603.2.17). Nuclear Hardness Critical Items are any items at any assembly level which are mission critical and could be designed, repaired, manufactured, installed or maintained for normal operation and yet degrade system survivability in a nuclear environment if hardness were not considered. Not only the top assembly for item(s) containing nuclear hardness critical components but subassemblies, detail drawings, schematics and wiring diagrams shall include the nuclear hardness critical note. In addition, the applicable Radiation Hardness Assurance (RHA) level shall be specified by a designator shown in FIGURE 400-5.

RHA Level Designator	Radiation and total dose (Rad <Si>)	Level Neutron fluence (n/cm ²)
M	3000	2×10^{12}
D	10^4	2×10^{12}
R	10^5	10^{12}
H	10^6	10^{12}

FIGURE 400-5. Radiation Hardness Assurance (RHA) Level

402.16.6.2 Processes. Nuclear Hardness Critical Processes (HCPs) shall also be identified on the drawing and drawing notes as applicable. HCPs are processes, specifications, and procedures which are hardness critical, and which, if changed, could degrade nuclear hardness.

402.16.6.3 Marking. HCIs shall be identified on the drawing by the symbol plus the RHA level designator. HCPs shall be identified with its symbol plus the RHA level designator. Identifiers shall be shown on the drawing adjacent to the feature/note in a box as defined below.

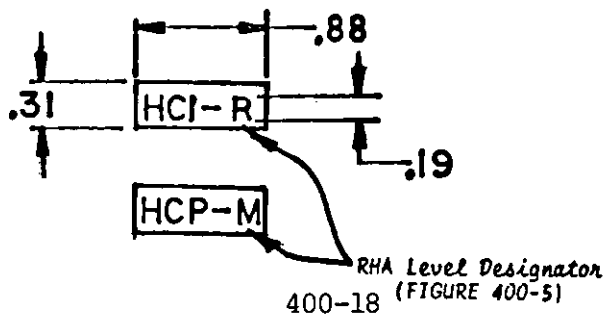

481

DOD-STD-00100D(AR)

NOTE: Drawings that depict HCIs or HCPs shall also have the following note shown on the face of the drawing. The pertinent identifier, Hardness Critical Item (HCI) or Hardness Critical Process (HCP) or both shall be indicated if applicable.

"THIS DRAWING DEPICTS HARDNESS CRITICAL ITEMS (HCI) AND (or) HARDNESS CRITICAL PROCESSES (HCP). ALL CHANGES TO OR PROPOSED SUBSTITUTIONS OF HCIs AND (or) HCPs MUST BE EVALUATED FOR HARDNESS IMPACTS BY THE ENGINEERING ACTIVITY RESPONSIBLE FOR SURVIVABILITY."

402.16.7 Critical Safety Items*. Each critical safety item and critical assembly process shall be clearly identified as such on the engineering part drawing or assembly drawing. The engineering drawing shall also clearly identify all critical characteristics* of that item.

402.16.7.1 Critical Safety Item Drawing. The drawing for a Critical Safety Item (CSI) shall have the following legend above the title block:

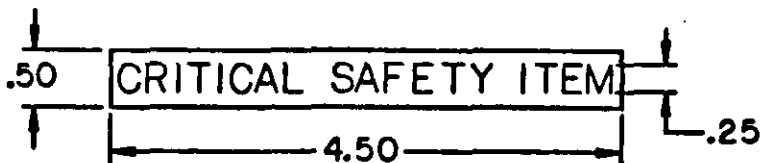

402.16.7.1.1 The following note shall be in the general notes:

* CRITICAL SAFETY CHARACTERISTICS ARE INDICATED WITH THE SYMBOL  "

a. The CSI symbol shall be adjacent to each critical dimension, tolerance, process note or other critical requirements. A leader line may be used to show a specific location. The CSI symbol shall be as shown below:

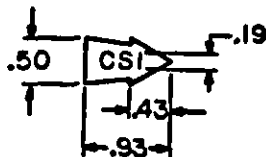

DOD-STD-00100D(AR)

b. Method of Identifying Critical Safety Items on drawings when a leader line is used shall be as shown:



The symbol may read left to right, up or down.

c. If the critical safety characteristic is a note, the symbol shall be placed at the end of the note as shown:



The critical safety item legend and symbol may be a decal, stencil or rubber stamp.

d. For A and B size drawings, the symbol may be typed as shown:

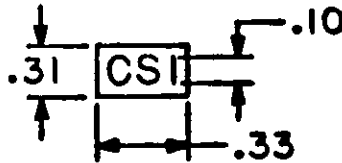

402.16.7.2 Critical Safety Item Assembly. If on an assembly drawing the process or method of assembly is critical, the same rules apply as for a drawing of a critical safety item.

DOD-STD-00100D(AR)

402.16.8 Sensitive electronic devices (SED). Detail, assemblies, equipment/equipment enclosures, kit, installation and package content drawings for electrical and electronic parts classified in accordance with DOD-STD-1686 and DOD-HDBK-263 as sensitive to damage from electrostatic discharge shall be annotated as follows:

- a. The following symbol and note shall be placed adjacent to the title block.

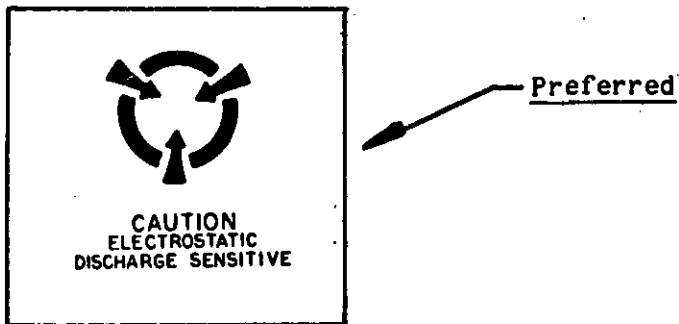

FIGURE 400-6. Sensitive electronic devices (SED) symbol

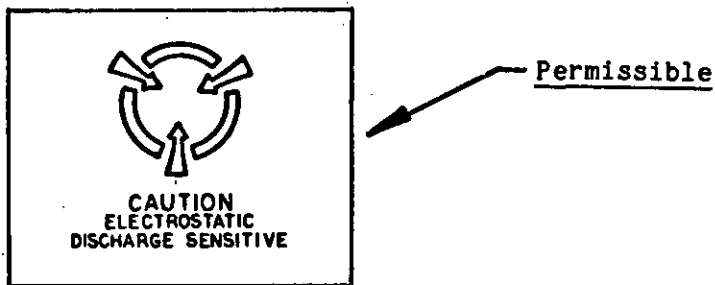

FIGURE 400-6a. Alternative Sensitive electronic devices (SED) symbol

DOD-STD-00100D(AR)

b. Protective handling procedures shall be specified in the general notes using the applicable version of the following note:

(1) When Class 1 or 2 applies:

"ELECTROSTATIC DISCHARGE CONTROL PROGRAM FOR PROTECTION OF ELECTRICAL AND ELECTRONIC PARTS, ASSEMBLIES AND EQUIPMENT SHALL BE IN ACCORDANCE WITH DOD-STD-1686 CLASS _____ AND DOD-HDBK-263."

SPECIFY CLASS 1 OR 2
WHICHEVER IS APPLICABLE



(2) When Class 3 applies:

"ELECTROSTATIC DISCHARGE CONTROL PROGRAM FOR PROTECTION OF ELECTRICAL AND ELECTRONIC PARTS, ASSEMBLIES AND EQUIPMENT SHALL BE IN ACCORDANCE WITH DOD-STD-1686 AND DOD-HDBK-263, CLASS 3."

188/

DOD-STD-00100D(AR)

402.17 Original date. The method for specifying the date on a drawing shall be numerical - year, month, day (e.g., 75-10-15). The method of specifying numerals less than ten shall include zero, e.g., "01".

402.18 Order of precedence of specifications and standards. Where identical items are identified by more than one document, the document to be utilized shall be selected in accordance with the order of precedence specified in MIL-STD-143. Selection shall be limited to the groups listed in APPENDIX I.

402.19 Interface Control Identification Symbol. Features which are identified for interface control shall be flagged with the symbol shown below. Interface flagging shall be only as directed by the Government Design Activity. The approximate size of the symbol shall be as shown:

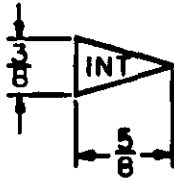

402.19.1 Location of symbol. The symbol shall be placed adjacent to the requirement if in note form and under the dimension for the feature as shown in the following example:

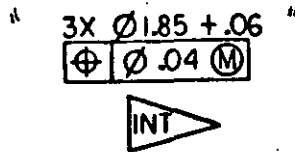

a. When interface dimensions are tabulated, the table shall include a column for entry of interface symbols next to appropriate dimensions.

b. On drawings containing interface dimensions, the following note shall be in the general notes:



DOD-STD-00100D(AR)

402.20 Item replacement notation.

402.20.1 Interchangeable items. When an item is replaced by another existing or new item, which is physically and functionally interchangeable, the note "FOR NEW DESIGN WORK AND PROCUREMENT USE *Part/MS/Specification NUMBER*", shall be applied over the title block of the drawing for the replaced item, as shown in FIGURE 400-7. The new item will replace the old in all present and future applications. The addition of the note constitutes a change; therefore, an applicable entry in the revision block in accordance with Chapter 500 is required.

FOR NEW DESIGN WORK AND
PROCUREMENT USE PART NO. 1234XXX7

CONTRACT NUMBER		DESIGN ACTIVITY		
CONTRACTOR				
DRAWN BY	DATE (YR-MO-DA)			
CHECKER	ENGINEER			
DRAWING APPROVAL		SIZE	CAGE CODE	
DESIGN APPROVAL		SCALE	UNIT WT	SHEET

FIGURE 400-7. Example of Interchangeable Parts Notation

DOD-STD-00100D(AR)

402.20.2 Non-Interchangeable items. When an item is to be replaced by another existing or new item which provides a design improvement but is not interchangeable, the note "FOR NEW DESIGN WORK USE *Part/MS/Specification NUMBER*", shall be applied over the title block of the drawing for the replaced item as shown in FIGURE 400-8. The new item will replace the old item only in new design work. The old item will continue to be used in all its applications. The addition of the note constitutes a change; therefore, an applicable entry in the revision block in accordance with Chapter 500 is required.

The diagram shows a drawing title block with a callout note. The callout note is a cloud-shaped bubble containing the text: "FOR NEW DESIGN WORK USE PART NO. I23XXXX9". Below the callout note is the title "PART NO.". The title block itself is a rectangular box divided into several sections:

CONTRACT NUMBER		DESIGN ACTIVITY	
CONTRACTOR			
DRAWN BY	DATE (YR-MO-DA)		
CHECKER	ENGINEER		
DRAWING APPROVAL		SIZE	CAGE CODE
DESIGN APPROVAL		SCALE	UNIT WT
		SHEET	

Dimensions A and B are indicated on the right side of the title block.

FIGURE 400-8. Example of Non-Interchangeable Parts Notation

DOD-STD-00100D(AR)

402.20.3 Obsoleted items. When an item is no longer used and not replaced by another item, the word "OBSOLETE" shall be added to its drawing over the title block as shown in FIGURE 400-9. When a drawing consists of multi-sheet and/or book-form the "OBSOLETE" cloud shall be added to all sheets. The addition of the word constitutes a change; therefore, an applicable entry in the revision block in accordance with Chapter 500 is required.

The diagram shows a drawing title block with a jagged line on the top and left edges, indicating a revision. A cloud-shaped label with the word "OBSOLETE" is placed over the top portion of the title block. The title block is divided into several sections:

CONTRACT NUMBER		DESIGN ACTIVITY	
CONTRACTOR			
DRAWN BY	DATE (YR-MO-DAY)		
CHECKER	ENGINEER		
DRAWING APPROVAL		SIZE	CAGE CODE
DESIGN APPROVAL		SCALE	UNIT WT
		SHEET	

FIGURE 400-9. Example of Obsolete Notation

192

DOD-STD-00100D(AR)

402.20.4 Superseded items. When an item is replaced by another item (different number) or when a drawing is redrawn (same number), the word "SUPERSEDED" shall be added to the old drawing over the title block as shown in FIGURE 400-10. Revision block entries shall be in accordance with Chapter 500.

The diagram shows a drawing title block with a cloud-shaped stamp reading "SUPERSEDED" placed over the top portion. The title block is divided into several sections:

CONTRACT NUMBER		PART NO.	
CONTRACTOR		DESIGN ACTIVITY	
DRAWN BY	DATE (YY-MM-DD)		
CHECKER	ENGINEER		
DRAWING APPROVAL		SIZE	CAGE CODE
DESIGN APPROVAL		SCALE	UNIT WT
		SHEET	

Dimensions A and B are indicated on the right side of the title block.

FIGURE 400-10. Example of Superseded Notation

DOD-STD-00100D(AR)

402.20.5 Notation size and location. Notations cited in paragraph 402.20.1, 402.20.2, 402.20.3, and 402.20.4 shall be stamped or printed in characters not less than 1/4 inch high, as near to the title block as possible, preferably just above the title block. The notation shall be encircled with a wavy line or cloud.

402.21 Ordnance Engineering Standards (TAXI). Parts described by Ordnance Engineering Standards drawings shall not be used for new design. Equivalent Military Standard or Specification shall be specified. If none exist, an applicable product drawing shall be prepared.

402.22 Identifying optional parts. Optional parts/assemblies shall be identified on assemblies/installation drawings as indicated.

" 2-TERMINAL-127XXXX1]-OPTIONAL "
2-TERMINAL-128XXXX2]

402.23 Distribution Statement. A Distribution Statement shall be specified in the location on the drawing in accordance with APPENDIX H. The distribution statement to be specified shall be as provided by the Government Design Activity.

DOD-STD-00100D(AR)

402.24 Duplicate original. When a drawing is replaced by the duplicate original process (same number), the words "DUPLICATE ORIGINAL" shall be added to the drawing in the lower right hand border as shown in FIGURE 400-11. The addition of the words constitutes a change; therefore, an applicable entry in the revision block in accordance with Chapter 500 is required.

195

2		1			
REVISIONS					
ZONE	LTR	DESCRIPTION	DATE (YR-MO-DA)	APPROVED	
	C	REPLACED WITHOUT CHANGE NOR WBA2300	78-01-23	78-03-23	

PART NO.

CONTRACT NUMBER		DESIGN ACTIVITY			
CONTRACTOR					
DRAWN BY	DATE (YR-MO-DA)				
CHECKER	ENGINEER				
DRAWING APPROVAL		SIZE	CAGE CODE		
DESIGN APPROVAL		SCALE	UNIT WT	SHEET	

DUPLICATE ORIGINAL

FIGURE 400-11. Example of Duplicate Original notation

DOD-STD-00100D(AR)

THIS PAGE LEFT BLANK INTENTIONALLY

981
196

DOD-STD-00100D(AR)

**CHAPTER 500
REVISION OF ENGINEERING DRAWINGS**

500 General. This chapter covers methods for revising engineering drawings and for identifying and recording revisions on original drawings.

501 Definitions. Definitions for words and terms marked with an asterisk (*) are located in Chapter 700.

502 Revision methods. Revisions* shall be made by erasure, addition of information or by redrawing.

502.1 Change in dimensions. In general, any change in a dimension of a part should also be made to scale on the affected portion of the delineation; however, it is permissible to leave the delineation unchanged when the new proportion of the part is not noticeably different from the original one. If change to scale is not made, the practice outlined in ANSI Y14.5M-1982 shall be followed. If the drawing is redrawn, delineation shall be made to scale.

502.2 Crossing out. Crossing out method of revision shall not be used.

502.3 Drawing practices. When revising an existing engineering drawing, the graphic symbols, designations, lettering style and size, material (lead/ink) and method of application and drawing practices (line width etc.) used in creating the original drawing format shall be followed for any changes unless otherwise directed by the Government Design Activity. When a drawing is being revised and does not reference the dimensioning and tolerancing standard, a determination of the applicable standard shall be made using the matrix depicted in FIGURE C-1 and the proper standard, or reference to that drawing (12579607), be specified in the general notes.

503 Identifying revisions on drawings.

503.1 Identifying revision locations. The location of revisions on the drawing shall be identified by one of the following methods as directed by the Government Design Activity in accordance with APPENDIX E.

- a. Description in the revision block.
- b. Zone in the zone column within the revision block.
- c. Revision authorization document referenced in the description block.
- d. Combinations of a, b, and c above when required for clarity.

503.2 Revision letters. Upper case letters shall be used in alphabetical sequence. The letters "I", "O", "Q", "S", and "Z" shall not be used. When revisions are numerous enough to exhaust the alphabet, the revision following "Y" shall be "AA", and the next "AB", then "AC", etc. Should "AA" to "AY" be exhausted, the next sequence shall be "BA", "BB", etc. Revision letters shall not exceed two characters. The letter "X" shall only be used in accordance with methods described in APPENDIX E.

503.3 Multiple Changes. All changes to a drawing incorporated at one time shall be identified by the same revision letter.

DOD-STD-00100D(AR)

503.4 Additions. When a multi-sheet drawing is revised to add a new sheet(s), the following note, "THIS SHEET ADDED", shall be placed in the description block of the new sheet(s), in addition to other notations. See FIGURE 500-1.

REVISIONS					
ZONE	LTR	DESCRIPTION	DATE (YR-MO-DA)	APPROVED	
	C	THIS SHEET ADDED NOR W6A2235	76-01-16	76-03-18	---

FIGURE 500-1. Example of Revision Block Notation for Multi-Sheet Drawing

503.5 Change in rights to technical data. When the rights to a drawing change due to an engineering revision to the drawing, the right shall be so indicated in the description column of the revision block with the contract number under which the change was approved. See FIGURE 500-2.

NOTE: Reference to only a revision authorization document is not be acceptable in this case.

REVISIONS					
ZONE	LTR	DESCRIPTION	DATE (YR-MO-DA)	APPROVED	
	A	NOR W5A2678	76-01-18	76-05-24	---
	B	NOR W6A2317	76-12-21	76-12-30	---
	C	PROPRIETARY RIGHTS EXPIRED CONTRACT NO. DAA ----- NOR W7A2456	77-08-05	77-10-13	---

FIGURE 500-2. Example of Revision Block Notation for Changes in Drawing Rights

DOD-STD-00100D(AR)

503.6 Required revisions. Prior to Government acceptance of configuration management authority, changes to drawings and associated lists shall be recorded as a revision only as directed by the Government Design Activity. All subsequent changes to any aspect of the documents shall be recorded as a revision.

504 Recording revisions on drawings.

504.1 Revision block. The revision block format shall conform to requirements specified in APPENDIX A. To provide for future revisions, all of the space beneath the revision block on B size shall be left clear. On C size and larger, a minimum of 3.5 inches of clear space shall be provided under the revision block.

504.1.1 Letter. The identifying letter pertaining to the particular revision being recorded shall be entered in the LTR column.

504.1.2 Description. Changes shall be described in accordance with APPENDIX E by method(s) as directed by the Government Design Activity.

504.1.3 Approval. Approval of the revision shall be indicated by signature of the authorized Government Design Activity representative entered in the APPROVED column with the associated date entered in the DATE column. See APPENDIX G for signature requirements for manual and CAD generated revisions.

a. CAD prepared drawings shall be signed for each revision. Subsequent generations may show printed signature(s) for those who initially signed the previous revision(s).

b. For microfilms generated directly from the computer without an original drawing (prior Government Design Activity approval is required), the signature and date shall be applied to the back of a master silver microfilm aperture card in a block duplicating that of the drawing format. See FIGURE 100-12. Subsequent generations may show printed signature(s) of those who initially signed the previous revision(s).

504.1.4 Zoning. When changes are recorded by zoning, the zone in which each change is made shall be entered in the ZONE column on the same line as the description of change.

504.1.5 Revision date. The date sequence shown in the revision block shall be the same as specified in 119.2, YR-MO-DA.

504.1.6 Separating revisions. Each revision shall be separated by a horizontal line drawn between each separate action.

DOD-STD-00100D(AR)

505 Revision of Multi-sheet and book-form drawings.505.1 Procedure.

a. Concurrent changes made upon any or all sheets of a multiple-sheet or book-form drawing shall be identified on each sheet so revised by the same revision letter. Each revision affecting any or all sheets shall be identified on the revision record sheet or status of sheets block on sheet 1. See FIGURE 500-3.

b. The revision status of each sheet comprised in the group shall be indicated on Sheet 1 in revision status block. For all sheets that have never been revised, a dash shall be entered in appropriate box.

c. A revision to any sheet requires a rise in the revision level of that sheet.

d. An entry in the revision status summary requires that the revision level of Sheet 1 also be raised. Sheet 1 is revised whenever any sheet is revised; therefore, the revision of Sheet 1 represents the revision level of the entire document.

e. Unchanged sheets retain the revision levels which are carried forward on the revision status summary. Only one line of revision symbols shall be utilized in the revision status block. See FIGURE 500-4.

f. No sheet may contain a revision level higher than that shown for Sheet 1. Concurrent changes to any or all sheets shall be identified by the same revision letter. See FIGURE 500-3.

505.2 Adding sheets to multi-sheet and book-form drawings. Added sheets constitute a change to the drawing and shall be entered at the revision level next in sequence for sheet 1. This revision shall be entered both on the added sheet and on the revision status summary. Additional sheets inserted between existing sheets require renumbering of all subsequent sheets. The action shall be explained on the Notice of Revision, e.g., "ADDED NEW SHEET 5, SHEETS PREVIOUSLY NUMBERED 5 THROUGH 13, RENUMBERED 6 THROUGH 14." When all sheets of an existing multi-sheet drawing contain the same original date, added sheets shall be assigned an original date identical to that shown on the existing sheets. When all sheets of an existing multi-sheet drawing do not contain the same original date, added sheets shall be assigned the date of the revision when they were added as their original date. When one or more sheets are added to an existing (single sheet) drawing, added sheet(s) shall be assigned an original date identical to that shown on the existing sheet.

505.3 Deleting sheets from multi-sheet and book-form drawings. When sheets are deleted, the remaining sheets shall be renumbered to retain the sequential order. The revision of sheet 1 shall be raised, and the revision status summary shall indicate that the deletion(s) occurred at the end of the order. The action shall be explained on the Notice of Revision, e.g., "SHEETS 5 AND 6 DELETED, SHEETS PREVIOUSLY NUMBERED 7 THROUGH 14, RENUMBERED 5 THROUGH 12". When sheets are deleted, the word "OBSOLETE" shall be added to the sheet over the title block as shown in FIGURE 400-13. The addition of the word "OBSOLETE" constitutes a change; therefore, an applicable entry in the revision block is required.

DOD-STD-00100D(AR)

ADDED NEW SHEETS 1 AND 3 NOTE: ALL SHEETS TO BE RENUMBERED.	F	F	F	F	F
SHEET 3 IS DELETED NOTE: REVISION LEVEL OF SHEET 3 IS RAISED. SHEET 4 IS RENUMBERED TO SHEET 3.			B	B	B
CHANGES TO SHEETS 1 AND 2 ADDED SHEET 4 NOTE: SHEET 4 STARTS AT "B" REVISION		B	C	B	B
CHANGES TO SHEETS 1 AND 3			C	B	C
CHANGES TO ALL SHEETS NOTE: SHEET 3 BECOMES REVISION "B" NOT "A"			B	B	B
CHANGES TO SHEETS 1 AND 3. CHANGES MAY BE DESCRIBED IN REVISION BLOCK OR ON MOR			A	-	A
3 SHEET DOCUMENT - INITIAL RELEASE			-	-	-
TYPE OF CHANGES TO DOCUMENTS	SH5	SH4	SH3	SH2	SH1
REVISION OF STATUS ENTRY					

FIGURE 500-3. Typical change and effect on revision status block and revision status of drawing sheets (1 through 5)
Example only, not to appear on the drawing

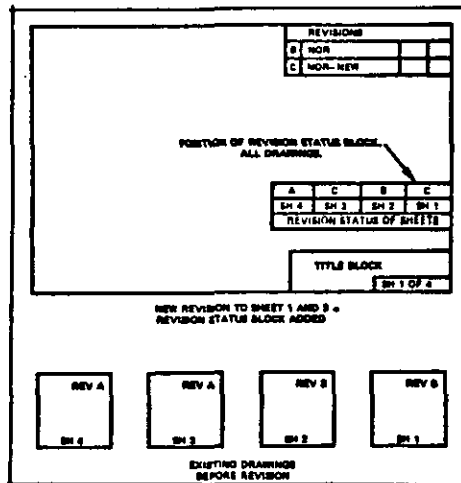

FIGURE 500-4. Revision status to existing drawings

DOD-STD-00100D(AR)

505.4 Computer generated/revised drawings. In the case of computer generated/revised book-form drawings, all sheets shall be identified by the same revision letter without regard to the specific sheet(s) to which the revision applies.

506 Redrawn or replaced drawings.

a. Redrawn with same number.

(1) Superseding (new) drawing. The original date of the old drawing shall apply for the new drawing. The revision block of the new drawing shall contain notation as shown in FIGURE 500-5. Changes shall be described in accordance with APPENDIX E by method(s) as directed by the Government Design Activity. All previous revision symbols, cross-outs and revision notations shall be omitted from the superseding drawing.

Enter description of change or reference to the change authorization document. See Appendix E.

Enter notation

REVISIONS				
ZONE	LTR	DESCRIPTION	DATE (YR-MO-DA)	APPROVED
		REDRAWN WITH CHANGE, -----,		
		or if applicable, enter notation		
		REDRAWN WITHOUT CHANGE, -----,		
		Enter reference to the redraw authorization document		
		Enter next sequential revision symbol and date and approval signature		

202

FIGURE 500-5. Superseding (new) Drawing Notations Redrawn with Same Number

DOD-STD-00100D(AR)

(2) Superseded (old) drawing. Notation as shown in FIGURE 500-6 shall be entered in the revision block of the superseded drawing. The word "SUPERSEDED" shall be added just above the title block as shown in FIGURE 400-10.

REVISIONS				
ZONE	LTR	DESCRIPTION	DATE (YR-MO-DAY)	APPROVED
		REPLACED WITH CHANGE BY REV		
		REPLACED WITHOUT CHANGE BY REV		

Do NOT enter revision symbol or date or signature

Enter notation

Enter next sequential revision symbol

or if applicable, enter notation

Enter next sequential revision symbol

203

FIGURE 500-6. Superseded (old) Drawing Notations Redrawn with Same Number

DOD-STD-00100D(AR)

b. Replacing drawing with different number.

(1) Superseding (new) drawing. Notation as shown in FIGURE 500-7 shall be entered in the revision block of the superseding drawing. The drawing shall contain an original date different than the superseded drawing. Changes shall be described in accordance with APPENDIX E by method(s) as directed by the Government Design Activity.

REVISIONS				
ZONE	LTR	DESCRIPTION	DATE (YR-MO-DA)	APPROVED
		REPLACES WITH CHANGE DRAWING 123XXXX7 REV (OR) DATED _____		

Enter notation

Enter replaced drawing number

Enter replaced drawing revision symbol. If no revisions, enter original date

Enter description of change or reference to the change authorization document.

Do NOT enter revision symbol or date (original drawing date applies)

FIGURE 500-7. Superseding (new) Drawing Notations Replacing Drawing with Different Number

DOD-STD-00100D(AR)

(2) Superseded (old) drawing. Notation as shown in FIGURE 500-8 shall be entered in the revision block of the superseded drawing. The word "SUPERSEDED" shall be added just above the title block, as shown in FIGURE 400-10.

REVISIONS				
ZONE	LTR	DESCRIPTION	DATE (YR-MO-DA)	APPROVED
		REPLACED WITH CHANGE BY DRAWING 123XXX8 REV _____ (OR) DATED _____		

Enter notation

Enter replacing (new) drawing number

Enter replacing drawing revision symbol. If no revisions, enter original date.

Enter description of change or reference to the change authorization document

Enter next sequential revision symbol and date and approval signature

FIGURE 500-8. Superseded (old) Drawing Notations Replaced by Drawing with Different Number

DOD-STD-00100D(AR)

507 Reinstating a replaced/superseded/obsoleted drawing. The applicable notation (See FIGURES 400-8, 400-9, 400-10 and 400-11.) shall be removed from the drawing. This action constitutes a change; therefore, revision block entries are required. The next sequential revision letter shall be entered. The reason for reinstating the drawing shall be described in accordance with APPENDIX E by method(s) as directed by the Government Design Activity.

508 Associated List(s) revisions. Associated lists shall be revised as necessary for compatibility with related drawing changes. Changes shall be identified and described in accordance with APPENDIX E by method(s) as directed by the Government Design Activity.

509 Identification of Configuration Management Baselines.

a. When Level 3 drawings are initiated during the validation phase of the acquisition cycle and if they become part of the Allocated Baseline, they shall be identified as shown in FIGURE 500-9.

XB	DIM .06+.01 WAS .08+.03	78-05-12	~
XC	ALLOCATED BASELINE ERR A7A250I	78-07-19	~

FIGURE 500-9. Example of Notation for Allocated Baseline

b. As Level 3 drawings mature during full scale development and become part of the Product Baseline, they shall be identified as shown in FIGURE 500-10.

—	PRODUCT BASELINE ERR FOM K2650	79-02-10	—
---	-----------------------------------	----------	---

FIGURE 500-10. Example of Notation for Product Baseline

DOD-STD-00100D(AR)

**CHAPTER 600
ASSOCIATED LISTS**

600 General. This chapter establishes minimum requirements for the preparation of Associated Lists.

a. Associated Lists will be prepared only when required by the Government Design Activity.

b. Information regarding procedure, forms, and design activity logo will be provided by the Government Design Activity when appropriate.

601 Definitions. Definitions for words and terms marked with an asterisk (*) are located in Chapter 700.

601.1 Parts list (PL). A parts list is a tabulation of all parts and *bulk materials (except those materials which support a process) used in the item to which the list applies. Reference documents may also be tabulated on a parts list. Items listed on a subordinate assembly parts list or specified in a referenced document need not be repeated in the using assembly parts list unless it is necessary to limit options permitted by the subordinate document.

NOTE: The term "List of Materials" (LM) is no longer used; it was formerly used interchangeably with Parts List (PL).

NOTE: Whenever Parts Lists are used, a note, **SEE SEPARATE PARTS LIST-120XXX5-1** shall be located above the title block of the parent engineering drawing. See FIGURE 200-8.

601.2 When PLs are required, a separate parts list shall be prepared for each assembly regardless of what level the assembly is used within the equipment or system. Drawings and other documents to be listed shall be segregated into groups as specified in the parts list detail requirements of this standard.

602 General Requirements.

602.1 List preparation. Parts lists may be prepared manually or by the application of automatic data processing system (ADPS) techniques. The type(s) of list(s) to be prepared, drawing assembly level at which lists will be prepared, and whether parts lists shall be prepared integral to or separate from the drawing shall be as determined by the Government Design Activity. Lists prepared integral to the drawing shall follow format design and location shown in FIGURE A-3, in accordance with ANSI Y14.1. Entries shall follow rules established for appropriate columns as provided in this chapter.

602.1.1 Manual preparation. Separate Parts Lists prepared manually shall utilize 8-1/2 x 11 inch size format and follow format design and preparation requirements as provided herein. See FIGURE 600-1.

DOD-STD-00100D(AR)

PARTS LIST		1 DESIGN ACTIVITY				2 CAGE CODE CURRENT ORIGINAL		3 ORIG DATE (YR-MO-DA)		4 PL		
5 LIST TITLE						6 AUTHENTICATION			7 SHEET OF SHEETS			
									8 DWG NO.			
9 FIND NO.	10 QTY REQD	11 CAGE CODE	12 PART OR IDENTIFYING NO.	DRAWING/DOCUMENT		13 NOMENCLATURE OR DESCRIPTION				16 SUPPL LIST	17 NOTES	
				13 SIZE	14 NUMBER							

FIGURE 600-1. Manually Prepared Parts List Format

This sample drawing is informational only and complete to the degree necessary to illustrate a type of drawing. Actual format and drawing shall conform to the textual requirements set forth in this standard.

U.S. ARMY
 ARMAMENT RESEARCH, DEVELOPMENT AND ENGINEERING CENTER
 PENTAGON ARSINAL, NEW JERSEY 07060-0000

CURRENT CASE CODE 15200 - ORIGINAL CASE CODE 15207

PL-10013599
 DOCUMENT/PART NUMBER P 10013599
 BODY ASSEMBLY
 CHANGE CONTROL NUMBER 00000001

REV. DATE 31 JAN 73
 REVISION LETTER P
 SHEET 3
 ORIG. DATE 30 JUN 64

AUTHENTICATION: *Signature*

FIG DTY UNIT CODE NO. REQ HEAD CODE	PART OR IDENTIFYING NO	DRAWING/DOCUMENT SIZE NUMBER	NOMENCLATURE OR DOCUMENT TITLE	QWP LIST
2	94906 H51045-20	H51045	SETSORE - HEXAGON, SOCKET, HALF - 000 POINT, UNC-2A	
2	94906 H51045-23	H51045	SETSORE - HEXAGON, SOCKET, HALF - 000 POINT, UNC-2A	
2	94906 H51045-40	H51045	SETSORE - HEXAGON, SOCKET, HALF - 000 POINT, UNC-2A	
2	94906 H51045-10	H51045	SETSORE, SLOTTED, CODE PT-COR RESIST, PVTB, UNF-2A	
1	94906 H51377-2	H51377	VALVE CORE, PNEUMATIC TIME-STANDARD DRUM	
1	94906 H51607-1	H51607	VALVE STEM, PNEUMATIC TIME FILTER	
2	94906 H51030-4	H51030	SEAL, METALLIC, LEAD AND TIN	
2	94906 H51057-12	H51057	SCREW, MACHINE-PAN HD, CROSS-RECESSED, CR6, UNC-2A	
2	94906 H51057-26	H51057	SCREW, MACHINE-PAN HD, CROSS-RECESSED, CR6, UNC-2A	
3	94906 H51057-20	H51057	SCREW, MACHINE-PAN HD, CROSS-RECESSED, CR6, UNC-2A	
6	94906 H51057-30	H51057	SCREW, MACHINE-PAN HD, CROSS-RECESSED, CR6, UNC-2A	
1	94906 H51057-43	H51057	SCREW, MACHINE-PAN HD, CROSS-RECESSED, CR6, UNC-2A	
2	94906 H51057-44	H51057	SCREW, MACHINE-PAN HD, CROSS-RECESSED, CR6, UNC-2A	
2	94906 H51057-46	H51057	SCREW, MACHINE-PAN HD, CROSS-RECESSED, CR6, UNC-2A	

TOTAL NUMBER OF SHEETS 3

U.S. ARMY
 ARMAMENT RESEARCH, DEVELOPMENT AND ENGINEERING CENTER
 PENTAGON ARSINAL, NEW JERSEY 07060-0000

CURRENT CASE CODE 15200 - ORIGINAL CASE CODE 15207

PL-10013599
 DOCUMENT/PART NUMBER P 10013599
 BODY ASSEMBLY
 CHANGE CONTROL NUMBER 00000001

REV. DATE 31 JAN 73
 REVISION LETTER P
 SHEET 1
 ORIG. DATE 30 JUN 64

AUTHENTICATION: *Signature*

FIG DTY UNIT CODE NO. REQ HEAD CODE	PART OR IDENTIFYING NO	DRAWING/DOCUMENT SIZE NUMBER	NOMENCLATURE OR DOCUMENT TITLE	QWP LIST
1	7649170	A 7649170	PLUG	
2	7649181	B 7649181	WASHER	
1	7649182	A 7649182	WASHER	
2	7649710	C 7649710	LENS, OBJECTIVE	
2	7649720	B 7649720	LENS, OBJECTIVE	
2	7649720	B 7649720	FILTER, GLASS	
2	7649725	C 7649725	LENS, OBJECTIVE	
1	0279046	B 0279046	SNELL	
1	0574040	A 0574040	ORACET	
1	0574001	C 0574001	SCREW	
2	0579003	A 0579003	LENS, OPTICAL INSTRUMENT, OBJECTIVE	
2	0579004	A 0579004	LENS, OPTICAL INSTRUMENT, OBJECTIVE	
2	0579005	A 0579005	LENS, OPTICAL INSTRUMENT, OBJECTIVE	
1	0580000	B 0580000	DECAL	
1	0580001	A 0580001	PLUG	
4	0589920-0	C 0589920	CAP ASSEMBLY	
2	10513551	A 10513551	SETSORE HEX SOCKET, CUP POINT	
2	10513556	B 10513556	SPACER	
2	10513557	B 10513557	SPACER	
2	10513558	B 10513558	RETAINER	
2	10513559	B 10513559	RETAINER	
2	10513560	B 10513560	RETAINER	
1	10513561	A 10513561	GASSET	
1	10513562	B 10513562	PLATE	
2	10513563	C 10513563	CELL	
2	10513564	C 10513564	HOUSING, OBJECTIVE	
2	10513564	B 10513564	CELL, CEMENTED	
2	10513566	B 10513566	RING	
1	10513570	B 10513570	SPRING, BONDED	
6	10513572	B 10513572	SPRING, COMPRESSION	
2	10513573	B 10513573	SPRING, COMPRESSION	
2	10513574	B 10513574	CONTACT	
2	10513576	C 10513576	SHIELD	
2	10513580	C 10513580	CELL ASSEMBLY	
2	10513581	C 10513581	ADAPTER, CEMENTED	
2	10513582	B 10513582	COVER	
2	10513583	C 10513583	SNOW DE	
2	10513584	A 10513584	RING, RETAINING	
2	10513587	C 10513587	ECCENTRIC, OUTER	
2	10513588	B 10513588	RING, RETAINING	
2	10513589	B 10513589	RING, RETAINING	
2	10513591	C 10513591	ECCENTRIC, INNER	
2	10513592	B 10513592	CELL	

AR - AS REQUIRED, ALT - ALTERNATE, OPT - OPTIONAL, SO - SELECTION OPTIONAL

FIGURE 600-3. Example of ADPS Prepared Parts List

This sample drawing is informational only and complete to the degree necessary to illustrate a type of drawing. Actual format and drawing shall conform to the textual requirements set forth in this standard.

DOD-STD-00100D(AR)

602.2 Multiple sheets. When more than a single sheet is required to prepare or revise a list, the list title may be shown on each sheet; however, it is required on the first sheet only. ADPS prepared sheets shall utilize the first or last sheet to indicate total number of sheets.

602.2.1 Sheet numbering. All sheets shall be numbered consecutively starting with number one (1) when prepared manually. The first sheet shall indicate the total number of sheets. ADPS prepared sheets shall utilize the first or last sheet to indicate total number of sheets. Sheets 2, 3, etc., shall bear sheet number only in this block.

602.2.2 Legibility requirements. Lists shall meet legibility requirements of MIL-D-5480.

602.2.3 List maintenance. Lists shall be maintained as separate original documents with appropriate revision levels and dates.

602.3 Revisions. Lists may be revised independently of the associated drawings; however, related changes should be incorporated concurrently.

602.3.1 Revision identification. A revision letter and the date of revision shall be applied to each list or each affected sheet of a list when any change is made. The letters "I", "O", "Q", "S", and "Z" shall not be used as revision letters. The letter "X" shall only be used in accordance with APPENDIX E by method(s) as directed by the Government Design Activity.

602.3.2 Deleting items. Items to be deleted shall be erased, or, when using ADPS techniques, omitted on the next list run.

602.3.3 Adding items. New or superseding items may be either added chronologically at the end of a list or inserted in the list in the proper sequence. Additional sheets may be added when the last sheet will not accommodate additions.

602.3.4 Revision description. A description of every change, addition or deletion processed shall be recorded in accordance with APPENDIX E by method(s) as directed by the Government Design Activity.

602.4 Design activity identification. The current design activity's name shall be entered on all associated lists in the block provided by format.

602.5 Block and column size and arrangement. The size and arrangement of all blocks and columns shall be determined by the preparing activity according to the method of preparation used.

602.6 Additional blocks and columns. Additional blocks and columns may be added for use of the preparing activity.

603 Parts list preparation.

603.1 Format. Parts lists shall be prepared in the format illustrated in FIGURE 600-1.

DOD-STD-00100D(AR)

603.2 Entries. Entries shall be made on the form single spaced as follows. The listing shall be in ascending numerical order by document number (See the instructions for entries in column 14).

603.2.1 Block 1, Design Activity Identification. The name of the original design activity whose CAGE Code appears in Block 2 as original shall be entered.

603.2.2 Block 2, CAGE Code. Enter the CAGE Code designating the original (and current if applicable) design activity on each sheet.

603.2.3 Block 3, Original Date. The date when the list is initially prepared is entered in this block. Enter date in six numeric characters, year-month-day, e.g., 72-04-28 (date authentication signature obtained). This method of dating will also be used for revision date in block 18.

603.2.4 Block 4, Parts List Number. Enter the identifying part number of the assembly drawing (see 402.8) with the letters "PL" on each sheet of the list.

603.2.5 Block 5, List Title. Enter the exact title from the title block of the drawing to which the list applies.

603.2.6 Block 6, Authentication Signature. The signature of the approving official is entered on all sheets. New authentication signature will be required on retyped lists.

603.2.7 Block 7, Sheet Number. Enter the appropriate sheet number of each sheet. The total number of sheets in the list shall be as specified in paragraph 602.2.1.

603.2.8 Block 8, Drawing Number. Enter drawing number preceded by the drawing size letter. For multi-sheet documents, enter size of sheet 1.

603.2.9 Column 9, Find Number. Enter find number for alternate/optional entries when used.

a. Alternate/optional parts or bulk items. The find number column on the parts list and the quantity required column will be used to indicate alternate/optional parts or bulk items. An alternate sequence number (e.g., "/1/," "/2/") will be shown for the preferred item in the find number column, and the actual quantity required will be shown in the "Quantity Required" column. The alternate/optional item is indicated by entering the same alternate sequence number as the preferred item in the find number column and the abbreviation "ALT" for alternate part; "OPT" for optional part will be shown in the Quantity Required column.

DOD-STD-00100D(AR)

EXAMPLE:

<u>Find No.</u>	<u>Qty Req</u>	<u>Identifying No.</u>	<u>Document No.</u>	<u>Nomenclature or Description</u>
/1/	AR	MMM-A-131T1C1-2	MMM-A-131	Adhesive, Glass-to Metal for Optical Elements Type 1, Class 1 and 2
/1/	ALT	MMM-A-131T2	MMM-A-131	Adhesive, Glass-to Metal for Optical Elements, Type 2

603.2.10 Column 10, Quantity Required. Enter the quantity for each item required to produce a single assembly to which the list pertains. The symbol AR (As Required) shall be used for bulk material. When AR is used, add "AR - As Required" at the end of the list. If other symbols are used, they will be explained at the end of the list.

603.2.11 Column 11, CAGE Code. Enter the appropriate CAGE Code assigned to the design activity whose document number appears in column 14. When the CAGE Code for an item is identical to that entered for the list (column 2), it is not necessary to repeat the Code in column 11. Whenever Government or Industry standards or specifications are specified as bulk item identifiers, the CAGE Code must be listed.

603.2.12 Column 12, Part or Identifying Number.

a. Enter the part number and dash number (when applicable) for parts and bulk material.

b. The part number will be repeated for each dash numbered item.

c. Enter MS or AN number and dash number in this column for parts so identified.

d. When an item is controlled by a military specification and is individually identified by a designation (such as RC20GF013J, UG-58 D/U), enter this designation.

e. When type, grade, class, condition, etc., are required for identification, such information shall be entered.

f. Part number sequence shall be determined by the listing order of Drawing/Documents Number listed in column 14.

603.2.13 Column 13, Drawing Size. Enter the letter size (sheet 1) of the drawing entered in column 14.

DOD-STD-00100D(AR)

603.2.14 Column 14, Drawing/Document Number. Enter the drawing or standard on which the number entered in column 12 is identified. Where specifications are used as identifying numbers, enter the complete specification identification (e.g., MIL-S-12345) in this column. The following shall apply for order of listing and for special consideration in specifying bulk issue and type designator items.

a. Order of listing. Listing shall be in ascending numerical order within the following order of document groupings: (This listing will coincide with order of listings on computer-generated parts lists).

Product Drawings

BFA (Ordnance Taxi Drawings) not to be used in new designs

Military Standards (MS)

The following shall be listed alpha-numerical in the following sequence:

Federal Specifications

Military Specifications

Miscellaneous

b. Identifying bulk issue, type designator items and reference drawings. These items shall be identified on a parts list in the following manner:

(1) Bulk Material Entries on Parts List. Where bulk material items are covered by a federal/military document with no selections, use the federal/military document number for the document number and the part number.

<u>Column 12</u> <u>PART NUMBER</u>	<u>Column 14</u> <u>DOCUMENT NUMBER</u>	<u>Column 15</u> <u>NOMENCLATURE OR DESCRIPTION</u>
QQ-W-470	QQ-W-470	WIRE, .004 DIA
MMM-A-131	MMM-A-131	ADHESIVE, TYPE 1
MMM-A-187	MMM-A-187	ADHESIVE
MIL-S-11030	MIL-S-11030	SEALING COMPOUND, TYPE 1
MIL-S-11031	MIL-S-11031	SEALING COMPOUND

(2) Specification type designator entries on parts list.

(a) When federal/military documents utilize the type designation system for identification of resistors, capacitors, etc., the following shall apply:

(A) Where the federal/military document has no subordinate slash sheets, use the federal/military document number as the document number and the type designator as the part number.

<u>Column 12</u> <u>PART NUMBER</u>	<u>Column 14</u> <u>DOCUMENT NUMBER</u>	<u>Column 15</u> <u>NOMENCLATURE OR DESCRIPTION</u>
RX29V100	MIL-R-19365	RESISTOR

(B) Where the federal/military document has subordinate slash sheets and the slash sheets have no subordinate designators, use the federal/military document number as the document number and the federal/military document number with slash sheet number as the part number.

DOD-STD-00100D(AR)

<u>Column 12</u> <u>PART NUMBER</u>	<u>Column 14</u> <u>DOCUMENT NUMBER</u>	<u>Column 15</u> <u>NOMENCLATURE OR DESCRIPTION</u>
MIL-C-27072/1	MIL-C-27072	CABLE

EXCEPTION: Where the federal/military document number with slash sheet number specifies only one item and has no identifying military part number, and this item has a recognized industry identifying number (i.e., semi-conductor devices, electron tubes, etc.), use the federal/military document number with slash sheet number as the document number and the industry number as the part number.

<u>Column 12</u> <u>PART NUMBER</u>	<u>Column 14</u> <u>DOCUMENT NUMBER</u>	<u>Column 15</u> <u>NOMENCLATURE OR DESCRIPTION</u>
2N706	MIL-S-19500/120	TRANSISTOR (MIL-S-19500)

(C) Where the federal/military document has subordinate slash sheets and the slash sheet has subordinate designators, use the federal/military document number with slash sheet number as the document number and the designator from the slash sheet as the part number.

<u>Column 12</u> <u>PART NUMBER</u>	<u>Column 14</u> <u>DOCUMENT NUMBER</u>	<u>Column 15</u> <u>NOMENCLATURE OR DESCRIPTION</u>
M5423/11-01 IECBA290EP	MIL-B-5423/11 MIL-C-38102/1	BOOT (MIL-B-5423) CAPACITOR (MIL-C-38102)

(3) Reference drawings entries. Use "REFERENCE DWG" in the Part of Identifying Number Column 12 to designate reference drawings (e.g., schematic diagram, wiring diagram, printed circuit master, etc.). Enter the reference drawing number in Column 14.

603.2.15 Column 15, Nomenclature or Description. Enter the nomenclature of the item whose part or identifying number appears in column 12.

603.2.16 Column 16, Supplemental List. Enter an "X" in line with each item (assembly) that has its own associated list(s).

603.2.17 Column 17, Notes. Enter letter symbols (three letters maximum) for appropriate entries where special notes are required. Symbols shall be approved by the Government Design Activity prior to use. The symbols and related notes will be entered at the end of the list.

603.2.18 Block 18, Revision Letter/Description/Date/Approval.

a. Revision Block. The revision block format shall conform to that shown in FIGURE 600-1. A revision block is not required on ADPS prepared lists; however, it shall contain the latest revision letter and date. See FIGURE 600-3.

b. Revision Letter. The identifying letter pertaining to the particular revision being recorded shall be entered in the LTR column. See APPENDIX E.

DOD-STD-00100D(AR)

c. Description. Changes shall be described in accordance with APPENDIX E by method(s) as directed by the Government Design Activity.

d. Date/Approval. Approval of the revision shall be indicated by signature of the authorized Government Design Activity representative entered in the ADPR column with the associated date entered in the DATE column.

603.2.19 Revision Letter/Date/Approval of ADPS Prepared Lists. Revision date and letter shall be shown for each sheet and be the same for all sheets. Approval shall be indicated by signature for each revision adjacent to AUTHENTICATION.

604 On Vehicle Equipment List (OVE). OVE lists designate equipment and material (such as shovels, first aid kits, machine gun mounts, etc.) which may be added to a system/subsystem. These items may be issued at the troop or depot levels, or may be required to be installed or furnished by the manufacturer. This list is identified or noted on Sheet 1 of the vehicle drawing (top assembly). There are two categories of OVE: BII and AAL. The On Vehicle Equipment (OVE) lists, consisting of the Basic Issue Items (BII) and Additional Authorized List (AAL) are the only lists that will be automatically prepared. The format shall be as directed by the Government Design Activity.

604.1 Basic Issue Items (BII). These are the minimum essential items required to place an end item in operation and to perform emergency repairs. This is equipment that is furnished with the end item, and must stay with the end item when it is issued or transferred between accountable officers.

604.2 Additional Authorized List (AAL). These are items available to the troops at the discretion of the Company Commander. These are usually items which are peculiar to the end item for a particular area or end item application. This list identifies items that do not have to accompany the end item when transferred between accountable officers.

605 Special Tool Set List. Special Tool Sets will be identified and noted on Sheet 1 of the vehicle drawing (top assembly). These are special tools peculiar to the support of the vehicle. They do not accompany the end item; they are for maintenance support units. The format shall be as directed by the Government Design Activity. They should be designated as:

TOOL SET, MAINT, ORG SPRT, A XXXXXXXX
 TOOL SET, MAINT, DIRECT SPRT, A XXXXXXXX
 TOOL SET, GENERAL SPRT, A XXXXXXXX
 TOOL SET, DEPOT SPRT, A XXXXXXXX

605.1 Special Tool Sets. Inasmuch as special tools do not constitute a functional or production assembly of the vehicle system, reference identification must be cited as indicated above to reflect data visibility/availability and maintenance considerations.

DOD-STD-00100D(AR)

**CHAPTER 700
DEFINITIONS**

This chapter establishes definitions for words and terms used in this Standard and Specification DOD-D-1000. Definitions have been developed specifically for support of the standard and specification or have been extracted from either the Federal Acquisition Regulation (FAR), DOD's Supplement (DFARS), Military Standards, or Department of Defense Instructions.

Acceptance. The act of an authorized representative of the Government by which the Government assumes for itself, or as an agent of another, ownership of existing and identified supplies tendered, or approves specific services rendered, as partial or complete performance of the contract on the part of the contractor.

Accessory. A part, subassembly, or assembly designed for use in conjunction with or to supplement another assembly, or a unit or set, contributing to the effectiveness thereof without extending or varying the basic function of the assembly or set. An accessory may be used for testing, adjusting, or calibrating purposes. (Examples: test instrument, recording camera for radar set, headphones, emergency power supply).

Allocated Configuration Identification (ACI). The ACI is the technical documentation governing and specifying the performance, physical, and interface requirements for CIs that are part of a higher level CI, typically a system; this documentation is in the form of specifications, drawings, and associated lists, and documents referenced therein, and is usually prepared during the validation phase. If there is no validation phase, the ACI may be prepared during the initial part of the full-scale development phase. Like the FCI, the ACI includes test provisions to assure all of the specified requirements are achieved by the developed CI.

Altered item. An altered item is one which, prior to the alteration, is taken from existing government stock or procured from a vendor and altered to meet design requirements. The item is then altered to meet specific design requirements.

Assembly. A number of parts or subassemblies or any combination thereof joined together to perform a specific function. (Examples: power shovel-front, fan assembly, audio-frequency amplifier).

NOTE: The distinction between an assembly and a subassembly is determined by individual application. An assembly in one instance may be a subassembly in another where it forms a portion of a higher assembly.

Associated list. A tabulation of pertinent engineering information pertaining to an item depicted on an engineering drawing or on a set of engineering drawings.

Attachment. A part, subassembly or assembly designed for use in conjunction with another assembly or a unit or set, contributing to the effectiveness thereof by extending or varying the basic function of the assembly, unit, or set. (Examples: hoisting attachment on a truck, milling attachment for a lathe).

DOD-STD-00100D(AR)

Base Line. A base line is a definitized status of a configuration identification (CI) document or a set of such documents, which describe a CI and/or the relationship between CIs, at a specified time during a CI's life cycle. (The record of the documentation revision status is maintained by the configuration status accounting system.) There are three initial base lines, the functional base line, the allocated base line, and the product base line, which are configuration identification departure points for further documentation development (documenting materiel development) in the validation phase, the full-scale development phase, and the production/deployment phase of the CI's life cycle. The relationship of these base lines to the various configuration identifications is as follows:

Allocated Base Line. The allocated configuration identification. See Base Line.

Functional Base Line. The functional configuration identification. See Base Line.

Product Base Line. The product configuration identification. See Base Line.

Bulk materials. Bulk materials are those necessary constituents of an assembly or part such as oil, wax, solder, cement, ink, damping fluid, grease, powdered graphite, flux, welding rod, thread, twine, and chain for which the quantity required is not readily predeterminable or if the quantity is known, the physical nature of the material is such that it is not adaptable to depiction on a drawing; or which can be cut to finished size by the use of such hand or bench tools as shears, pliers, knives, etc., without any further machining operations and the configuration is such that it can be fully described in writing without the necessity of pictorial representation.

Combination of items. A combination of items is defined as a single composite unit consisting of one or more items with the related equipment, tools, and spare parts which make the unit complete for issue. A combination may also consist of two or more items without equipment, tools, or spare parts.

Commercial item. A commercial item is a term which includes both supplies and services of a class or kind which (a) regularly is used for other than Government purposes and (b) is sold or traded in the course of conducting normal business operations.

NOTE: Services, per se, normally are not subject to delineation on engineering drawings.

Configuration Identification (CI). A configuration identification is the technical documentation which described design and/or product functional and/or fabricated requirements for CIs.

Contract. Contract means all types of agreements and orders for the procurement of supplies or services. It includes awards and notices of award; contracts providing for the issuance of job orders, task orders, or task letters thereunder; letter contracts, and purchase orders. It also includes supplemental agreements with respect to any of the foregoing.

DOD-STD-00100D(AR)

Contracting officer. Contracting officer means any person who, in accordance with departmental procedures, is currently designated a contracting officer with the authority to enter into and administer contracts and make determinations and findings with respect thereto, or with any part of such authority. The term also includes the authorized representative of the contracting officer acting within the limits of his authority.

Contractor. Contractor means any individual, partnership, public or private corporation, association, institution, or other entity which is a party to a contract.

Corner. An intersection of edges.

Critical safety characteristic. Any feature (i.e., tolerance, finish, material composition, manufacturing, assembly or inspection process) or product, material, or process, which if nonconforming or missing, could cause the failure or malfunction of the critical safety item.

Critical safety item. A part, assembly, installation, or production system with one or more critical characteristics that, if not conforming to the design data or quality requirements would result in an unsafe condition. Unsafe conditions relate to hazard severity categories I and II of MIL-STD-882, System Safety Program Requirements, and include conditions which could cause loss or serious damage to the end item or major components, loss of control, or serious injury to personnel.

Deficiencies. Deficiencies consist of two types:

a. conditions or characteristics in any hardware/software which are not in compliance with specified configuration, or

b. inadequate (or erroneous) configuration identification which has resulted, or may result, in configuration items that do not fulfill approved operational requirements.

Design activity, current. A government activity currently having responsibility for design, drawing and associated documents preparation/maintenance. Current design activity could be the original activity or new activity when that responsibility was transferred from another government (or contractor) organization.

Design activity, original. A Government design activity having had responsibility originally for the design of an item and whose drawing number and CAGE code is shown in the title block of all drawings and associated documents.

Design agent. A design agent is an activity contracted or tasked to develop details of a design for which the design activity retains responsibility.

Distribution Statement. A distribution statement identifies documents that contain information of which the dissemination is controlled by statute or regulation; also it indicates the extent of secondary distribution that is permissible without further authorization or approval of the originator.

DOD-STD-00100D(AR)

Document. Document applies to the specifications, drawings, lists, standards, pamphlets, reports, and printed, typewritten or other information, relating to the design, procurement, manufacture, test, or inspection of items or services under the contract.

Drawing format. A format in accordance with an accepted standard used for the preparation of an engineering drawing.

Duplicate original. A replica of an original engineering drawing made by a photo-duplicating technique, or a combination of a photo-duplicating technique and drafting on a medium (vellum, plastic base material, etc.) suitable for reproducing other reproducible and non-reproducible drawings.

Edge. A line of division bounded by two surfaces.

End-product (end-item). An end-product is an item, either an individual part or assembly, in its final or completed state.

Engineering data. Engineering documents such as drawings, associated lists, accompanying documents, manufacturer specifications, and standards, or other information prepared by a design activity and relating to the design, manufacture, procurement, test, or inspection of items or services.

Exterior corners and edges. Corners and edges having included angles less than 180 degrees (measured through the material).

Exterior Edge/Corner Break. Unless otherwise specifically defined with a radius or chamfer requirement, the phrase "SHALL BE BROKEN" is defined as either a radius or a basic 45 degree chamfer. Therefore, "SHALL BE BROKEN .02 + .02" allows a R .02 to R .04 or a basic 45 degree chamfer with sides from .02 to .04.

First tier. Normally used with specifications. The "top" specification. Other specifications reference the "top" or "first tier" specification.

Formal Engineering Change Control. The method of controlling revisions to engineering drawings by means of configuration management procedures involving release of data to the Technical Data Repository and subsequent preparation of Engineering Release Record(s) (ERRs), Engineering Change Proposal(s) (ECPs), Notice of Revision(s) (NORs) and related documentation.

Formulations. Formulations are mixtures such as explosives, fillers, propellants, pyrotechnics, etc. Each formulation is discretely identified. Formulations are not to be construed as "bulk materials".

Full Scale Development Phase. During this effort, the system, including all items necessary for its support, is designed, fabricated, and tested. The intended output is a hardware configured system and the documentation needed to produce the hardware. The objectives of Full-Scale Development are to ensure that the engineering design is completed, that all major problems have been resolved, and that this has been demonstrated by actual performance testing as systems progress through the development process. These objectives are under continuous review from the definition and refinement of requirements through the evaluation and selection of alternatives to the management and direction of production.

DOD-STD-00100D(AR)

Functional Configuration Identification (FCI). The FCI is the technical documentation for a CI as set forth in specifications, drawings, and associated lists, and documents referenced therein, which is initially prepared during the conceptual phase, to establish performance and physical requirements for a CI to be developed or produced. The FCI addresses the technical and mission requirements of a system (or major equipment) as an entity, and includes test provisions to assure requirements are achieved.

Government Design Activity. Government agency responsible, or scheduled to become responsible, for Configuration Management and design requirements of a Configuration Item.

Government drawing format. A drawing format on which a Department or Agency of the DOD affixes its identity.

Government procurement quality assurance (PQA). The function by which the Government determines whether a contractor has fulfilled his contract obligations pertaining to quality and quantity. This function is related to and generally precedes the act of acceptance.

Group. A collection of units, assemblies, or subassemblies which is a sub-division of a set or system, but which is not capable of performing a complete operational function. (Examples: antenna group, indicator group).

Interchangeable item. When two or more items possess such functional and physical characteristics as to be equivalent in performance and durability and capable of being exchanged one for the other without alteration of the items themselves or of adjoining items except for adjustment, and without selection for fit or performance, the items are interchangeable.

Interior corners and edges. Corners and edges having included angles greater than 180 degrees (measured through the material).

Item. A non-specific term used to denote any unit or product including materials, parts, assemblies, equipment, accessories, and attachments.

Level. Classification of engineering drawings as selected from DOD-D-1000.

Limited production. Production of only a few pieces as opposed to quantity (mass) production.

Manufacturer. Manufacturer is a person or firm

a. who owns, operates, or maintains a factory or establishment that produces on the premises the materials, supplies, articles, or equipment required under the contract or of the general character described by the specifications, standards, and publications; or

b. who, if newly entering into a manufacturing activity of the type described above, has made all necessary prior agreements for manufacture space, equipment, and personnel to perform the manufacturing operations required for contract performance.

DOD-STD-00100D(AR)

Matched parts. Matched parts are those parts, such as special application parts, which are machine matched, or otherwise mated, and for which replacement as a matched set or pair is essential.

Module. Depending upon context, the term "module" can mean any in a series of standard units for use together. A packaged functional assembly of electronic/mechanical components for use with other such assemblies. An independent unit that is a part of the total structure.

Non-part drawing. An engineering drawing that provides requirements, procedures, instructions, etc., applicable to an item, when it is not convenient to include this information on the applicable part drawing. Examples include test requirements drawing, wiring diagram drawing, etc.

Original date. An original date (located in the title block) is to establish a base line and is retained throughout the life of the drawing for historical record purposes.

Original drawing. An original drawing is the drawing or "marked" copy thereof on which is kept the revision record recognized as official by the design activity.

Part. One piece, or two or more pieces joined together, which are not normally subject to disassembly without destruction or impairment of designed use. (Examples: outer front wheel bearing of 3/4 ton truck, electron tube, composition resistor, screw, gear, mica capacitor, audio transformer, milling cutter.)

Part drawing. An engineering drawing that defines an item and assigns a part or control number to identify its configuration.

Product Configuration Identification (PCI). The PCI (also referred to as Technical Data Package) is the technical documentation establishing the technical requirements for production of Army materiel. The technical documentation shall specify form, fit, and function to insure interchangeability of CIs and/or detail design disclosure to permit the delivery of identical items, within specification tolerances, by qualified sources. This documentation is in the form of specifications, drawings, and associated lists, and documents referenced therein, and is initially prepared or acquired during the full-scale development phase. All items for which individual procurement is projected, repair parts as well as prime items, shall be supported by a PCI which includes performance and quality assurance requirements as well as form, fit, and function, and/or detail design disclosure, as applicable.

Production. The process of converting raw materials by fabrication into required material. It includes functions of production-scheduling, inspection, quality control, and related processes.

Proved. Use of an engineering drawing in producing, inspection, and testing of a satisfactory product.

Quality assurance. A planned and systematic pattern of all actions necessary to provide adequate confidence that the item or product conforms to established technical requirements.

DOD-STD-00100D(AR)

Repair part. Any part, assembly, or component that is required for installation in the maintenance of an end item.

Repairable. Having the capability of being repaired.

Replacement drawing. A replacement drawing is defined as a new original drawing substituted for the previous original drawing of the same drawing number.

Revision. The term revision refers to any change to an original drawing after that drawing has been released for use.

Revision authorization. A revision authorization is a document such as a Notice of Revision, Engineering Change Notice, or Revision Directive which describes the revision in detail and is issued by the activity having the authority to revise the drawing.

Revision symbol. A revision symbol is an identifying letter which may be accompanied by a suffix number and enclosed in a circle or, in the case of ADPS, may be the printed letter in a revision column or block.

Set. A unit or units and necessary assemblies, subassemblies, and parts connected or associated together to perform an operational function. (Set is also used to denote a collection of like parts such as a tool-set, or a set of tires). (Examples: radio receiving set; sound measuring set, which includes parts assemblies, and units as cable, microphone, and measuring instruments; radar homing set).

Standard, Government. Government standard is a standard developed by or for a Government Activity.

223
Standard, non-government. A nationally-recognized standardization document, issued with intent to establish common technical requirements by a non-government organization, which conducts professional standardization activities and which is not organized for profit. (Includes "INDUSTRY STANDARDS". Does not include "COMPANY STANDARDS").

Standard, sheet form. Sheet form standard is a standard prepared in format similar to the MS sheet format or MIL-STD unit page format.

Standards. Standards are documents that establish engineering and technical limitations and applications for items, materials, processes, methods, designs, and engineering practices.

Standards, Company. Company standards are those developed to establish engineering and technical applications for items, materials, processes, methods, designs, and engineering practices to facilitate standardization within that company.

Subassembly. Two or more parts which form a portion of an assembly or a unit replaceable as a whole, but having a part or parts which are individually replaceable. (Examples: gun mount stand, window sash, recoil mechanism, floating piston, telephone dial, Intermediate Frequency (IF) strip, terminal board with mounted parts).

DOD-STD-00100D(AR)

Sub-contractor. Supplier, distributor, vendor, or firm which furnishes supplies or services to or for a prime contractor or another sub-contractor.

Symmetrically opposite parts. Symmetrically opposite parts are those parts which are mirror images of each other.

System (electrical - electronics). A combination of two or more sets, generally physically separated when in operation, and such other assemblies and parts necessary to perform an operational function or functions. (Examples: Airborne early warning (AEW) electronic system, anti-aircraft defense system, telephone carrier system, Ground controlled approach (GCA) electronic system, fire control system including the tracking radar, computer, and gun mount).

System (general). A composite of equipment, skills, and techniques capable of performing or supporting an operational role, or both. A complete system includes all equipment, related facilities, material, software, services and personnel required for its operation and support to the degree that it can be considered a self-sufficient unit in its intended operational environment.

Unit. An assembly or any combination of parts, subassemblies, and assemblies mounted together normally capable of independent operation in a variety of situations. (Examples: Hydraulic jack, electric motor, electronic power supply, internal combustion engine, electric generator, radio receiver.)

NOTE: The size of an item is a consideration in some cases. An electric motor for a clock may be considered as a part inasmuch as it is not normally subject to disassembly.

Validation. The process by which the preparing activity for a document determines that the document reflects accurate and current requirements, including reference to current documents that are clearly and specifically applicable to the document being validated.

Validation Phase. The Validation Phase is the second effort of the weapon system life cycle. During this effort, the major characteristics of the program/project are defined and validated for the alternative(s) selected in the previous effort. Validation is the first step in the development phase during which preliminary design and engineering are verified or accomplished and firm contract and management planning are performed.

Vendor. A design non-Governmental activity, manufacturer, seller, wholesaler, or agent from whom are acquired items for use in the performance of the contract.

DOD-STD-00100D(AR)

Key word listing

Assembly
Associated List
Baseline
Bulk Material
Diagram
Document
Drawing
Government Design Activity
Item
Part
Revision
Standard
Subassembly
System
Title
Tolerancing
Vendor

Custodian:

Army - AR

Review Activity:

Army - AT

Preparing Activity:

Army - AR

(Project DRPR-A283)

225

DOD-STD-00100D(AR)

THIS PAGE LEFT BLANK INTENTIONALLY

DOD-STD-00100D(AR)

APPENDIX A

DRAWING FORMAT & SUPPLEMENTARY BLOCKS ENTRIES

Shall be in accordance with ANSI Y14.1-1980 except as described herein.

<div style="border: 1px solid black; width: 100px; height: 100px; margin: 0 auto;"></div>		CASE NO. DRAWING NO.
DRAWN BY	DATE (YR-MO-DA)	
CHECKER	ENGINEER	
DRAWING APPROVAL		
DESIGN APPROVAL		
MATL ENGR		
LTR	REVISION APPROVED	DATE (YR-MO-DA)

FIGURE A-2. Format for Aperture Card Signature/Revision Blocks

This sample drawing is informational only and complete to the degree necessary to illustrate a type of drawing. Actual format and drawing shall conform to the textual requirements set forth in this standard.

REVISIONS																			
SHEET (1/10)		DESCRIPTION				DATE (MM-DD-YY)		APPROVED											
<div style="position: absolute; top: 50%; left: 50%; transform: translate(-50%, -50%); font-size: 2em;">TO SUIT</div>																			
PARTS LIST																			
PART NO.																			
MECHANICAL PROPERTIES		PART I		UNLESS OTHERWISE SPECIFIED: DIMENSIONS ARE IN INCHES				CONTRACT NUMBER		DESIGN ACTIVITY									
TEMP				TOLERANCES ON 3 PLACE 3 PLACE ± ±				CONTRACTOR											
YS								DRAWN BY						DATE (MM-DD-YY)					
ELD								CHECKER						ENGINEER					
RA								DRAWER APPROVAL						SHEET		DATE CODE			
DN								DESIGN APPROVAL						SCALE		SHEET			
DN				MATERIAL		MATERIAL		MATERIAL		MATERIAL									
APPLICATION		USED ON																	

230

FIGURE A-3. Integral parts list (format and location)

This sample drawing is informational only and complete to the degree necessary to illustrate a type of drawing. Actual format and drawing shall conform to the textual requirements set forth in this standard.

DOD-STD-00100D(AR)

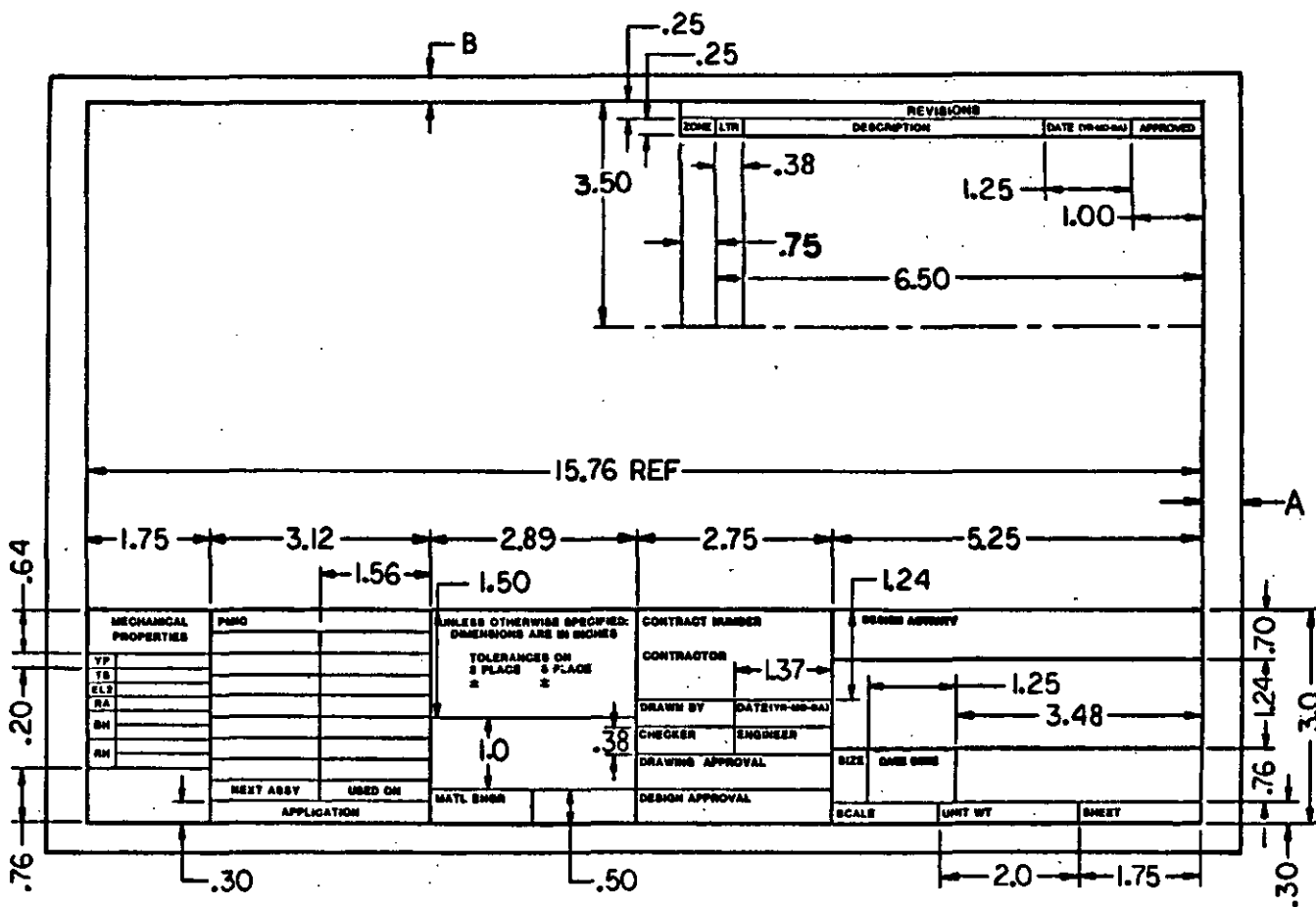

2-31

SIZE DESIGNATION	MARGIN	
	A	B
B	0.62	0.38
C	0.50	0.75
D	1.00	0.50
E	0.50	1.00
F	0.50	0.50
H	0.50	0.50
K	0.50	0.50

FIGURE A-4. Drawing format for B size and larger

This sample drawing is informational only and complete to the degree necessary to illustrate a type of drawing. Actual format and drawing shall conform to the textual requirements set forth in this standard.

DOD-STD00100D(AR)

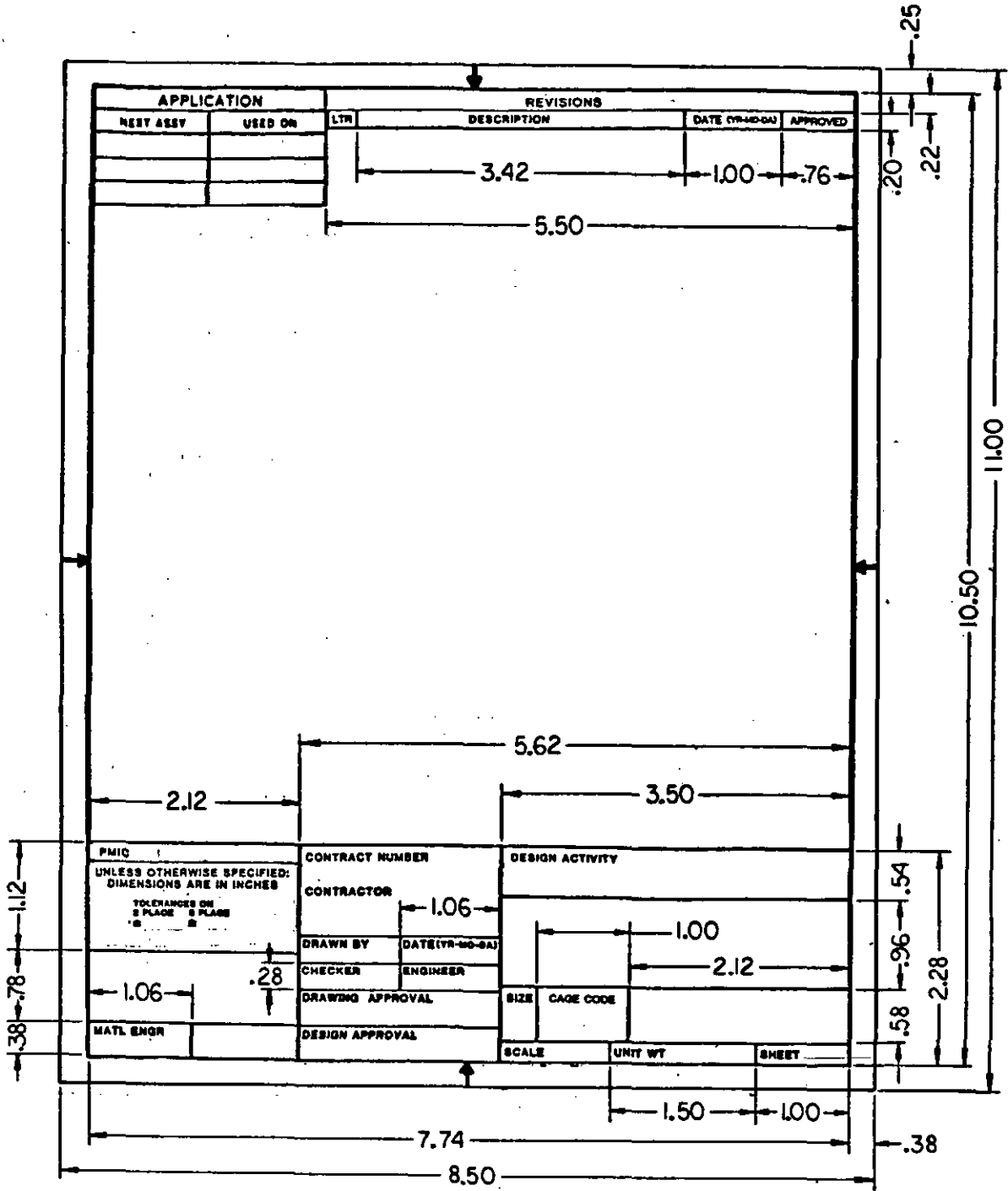

FIGURE A-5. Drawing format for A size

This sample drawing is informational only and complete to the degree necessary to illustrate a type of drawing. Actual format and drawing shall conform to the textual requirements set forth in this standard.

DOD-STD-00100D(AR)

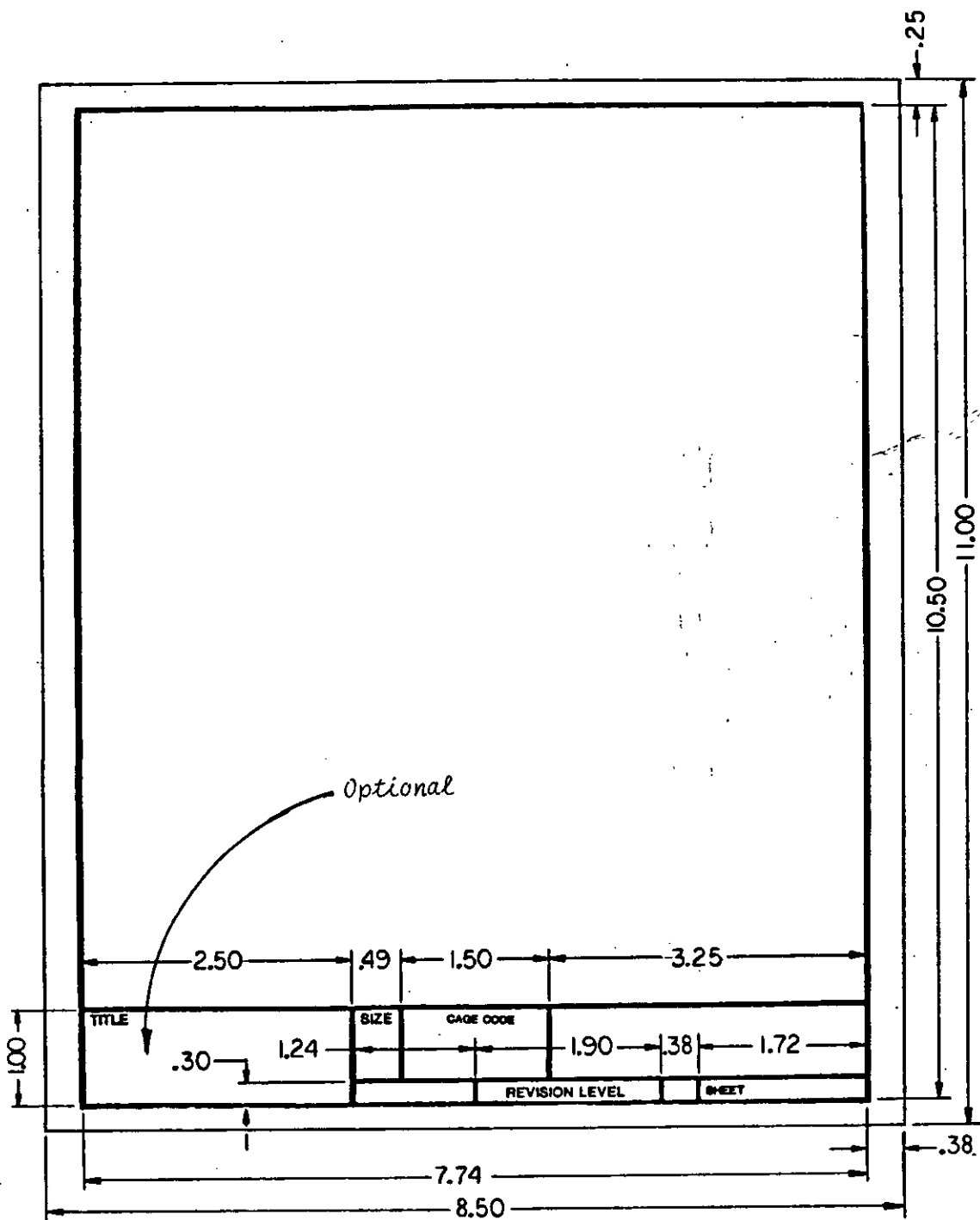

FIGURE A-6. Drawing format for A size continuation sheet

This sample drawing is informational only and complete to the degree necessary to illustrate a type of drawing. Actual format and drawing shall conform to the textual requirements set forth in this standard.

DOD-STD-00100D(AR)

NATIONAL STOCK NUMBER	COMBINATIONS OF ADOPTED ITEMS	DATE CODE	PART NO.

PART				CONTRACT NUMBER		DESIGN ACTIVITY	
REVISIONS				CONTRACTOR			
LTR	DESCRIPTION	DATE	APPD	DRAWN BY	DATE (YY-MM-DD)	COMBINATIONS OF ADOPTED ITEMS	
				CHECKED	ENGINEER		
				DRAWING APPROVAL		SIZE	DATE CODE
				DESIGN APPROVAL		UNIT BY	SHEET

FIGURE A-8. Drawing format for Combinations of Adopted Items drawing

This sample drawing is informational only and complete to the degree necessary to illustrate a type of drawing. Actual format and drawing shall conform to the textual requirements set forth in this standard.

PACKAGE STOCK NO. _____ PACKAGE NOMENCLATURE _____ THIS PACKAGE PERTAINS TO _____ PACKAGE CONTENTS																																																					
QTY	NAME OF ITEM	DWG NO.	CAGE CODE	PART NO.	STOCK NO.																																																
<table border="1" style="width: 100%; border-collapse: collapse;"> <thead> <tr> <th colspan="4">REVISIONS</th> </tr> <tr> <th style="width: 5%;">LTR</th> <th style="width: 25%;">DESCRIPTION</th> <th style="width: 15%;">DATE</th> <th style="width: 55%;">BY</th> </tr> </thead> <tbody> <tr><td> </td><td> </td><td> </td><td> </td></tr> <tr><td> </td><td> </td><td> </td><td> </td></tr> <tr><td> </td><td> </td><td> </td><td> </td></tr> <tr><td> </td><td> </td><td> </td><td> </td></tr> <tr><td> </td><td> </td><td> </td><td> </td></tr> <tr><td> </td><td> </td><td> </td><td> </td></tr> <tr><td> </td><td> </td><td> </td><td> </td></tr> <tr><td> </td><td> </td><td> </td><td> </td></tr> <tr><td> </td><td> </td><td> </td><td> </td></tr> <tr><td> </td><td> </td><td> </td><td> </td></tr> </tbody> </table>		REVISIONS				LTR	DESCRIPTION	DATE	BY																																									CONTRACT NUMBER _____ CONTRACTOR _____ DESIGNER _____ DATE _____ CHECKER _____ ENGINEER _____ DRAWING APPROVAL _____ DESIGN APPROVAL _____		DESIGN ACTIVITY _____ BOX _____ ONE USE _____ UNIT WT _____ SHEET _____	
REVISIONS																																																					
LTR	DESCRIPTION	DATE	BY																																																		

FIGURE A-9. Drawing format for Package Contents drawing

This sample drawing is informational only and complete to the degree necessary to illustrate a type of drawing. Actual format and drawing shall conform to the textual requirements set forth in this standard.

DOD-STD-00100D(AR)

APPENDIX B

SECURITY CLASSIFICATION MARKINGS AND NOTATIONS

237

B1 Security Classification and Notation. Location of espionage, special security and regrading notes shall be in accordance with DOD-5220-22 and the following:

B1.1 Assigning Classification. Security classification of drawings and associated lists shall be consistent with project/program classification. Classification of associated lists shall be based on the content of the list and not on the classification of the drawing.

NATIONAL SECURITY INFORMATION
UNAUTHORIZED DISCLOSURE SUBJECT
TO CRIMINAL SANCTIONS

THIS DOCUMENT CONTAINS HIGHLY SENSITIVE INFORMATION WHICH WOULD BE OF SIGNIFICANT INTELLIGENCE VALUE TO A POTENTIAL ENEMY. ACCESS WILL BE SEVERELY LIMITED TO THOSE INDIVIDUALS WHO MUST KNOW DESIGN DATA AND PRODUCTION TECHNIQUES OF IMPROVED CONVENTIONAL MUNITIONS IN ORDER TO EXECUTE OFFICIAL DUTIES.

SECRET

CONFIDENTIAL

RESTRICTED DATA

DOWNGRADE TO **SECRET**
ON _____
CONFIDENTIAL
ON _____
DECLASSIFY ON _____
CLASSIFIED BY _____

CLASSIFIED BY _____
EXEMPT FROM GDS OF EO 11652
EXEMPTION CATEGORY _____
DECLASSIFY ON _____

CLASSIFIED BY _____
SUBJECT TO GDS OF EO 11652
AUTOMATICALLY DOWNGRADED AT TWO
YEAR INTERVALS
DECLASSIFIED ON DECEMBER 31, _____

278

DOD-STD-00100D(AR)

B1.2 Application of Security Classification. Security classification markings shall be applied by decals, rubber stamps, or by lettering template. Markings shall meet the reproduction requirements of the drawing.

B1.3 Size of Security Markings. Security markings shall be equal to or larger than the largest lettering on the drawing or list.

B1.4 Color of Security Markings. All security classifications and notations shall be black.

RESTRICTED DATA
THIS MATERIAL CONTAINS RESTRICTED DATA
AS DEFINED IN THE ATOMIC ENERGY ACT OF
1954. ITS DISSEMINATION OR DISCLOSURE
TO ANY UNAUTHORIZED PERSON IS PROHIBITED.

CRITICAL NUCLEAR WEAPON
DESIGN INFORMATION
ODD DIRECTIVE 5210.2 APPLIES

UNCLASSIFIED CONTROLLED NUCLEAR INFORMATION
NOT FOR PUBLIC DISSEMINATION
Unauthorized dissemination subject to civil and criminal
sanctions under section 148 of the Atomic Energy Act of 1954,
as amended (42 USC 2168).

NOT FOR PUBLIC DISSEMINATION
May contain unclassified controlled nuclear information
Subject to Section 149 of the Atomic Energy Act of 1954
As amended (42 USC 2159). Approval by the Department
of Energy prior to release is required

NOT FOR PUBLIC DISSEMINATION
Unauthorized disseminations subject to civil and
Criminal sanctions under 42 USC 2168.

239

DOD-STD-00100D(AR)

B1.5 Location of Security Markings on Drawings. Security notations; i.e., espionage special security, and downgrading notes shall be placed above the title block on classified drawings. Security classification shall be located within the body of the drawing above and below the microfilm arrows. See FIGURE B-1. For the location on roll size drawings, see FIGURE B-2.

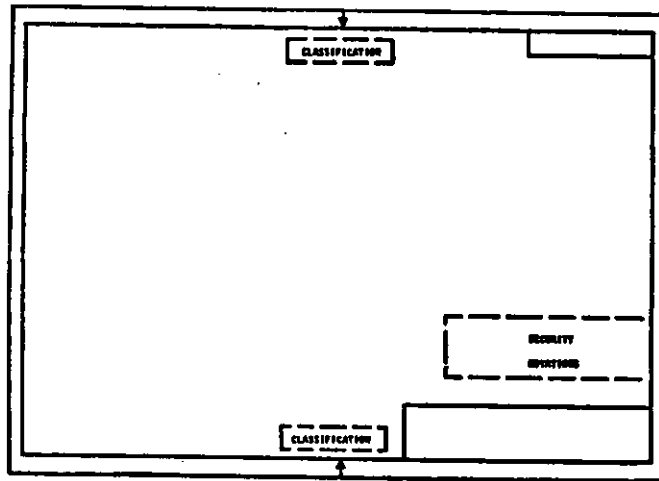

FIGURE B-1. Location of Security Markings on Drawings

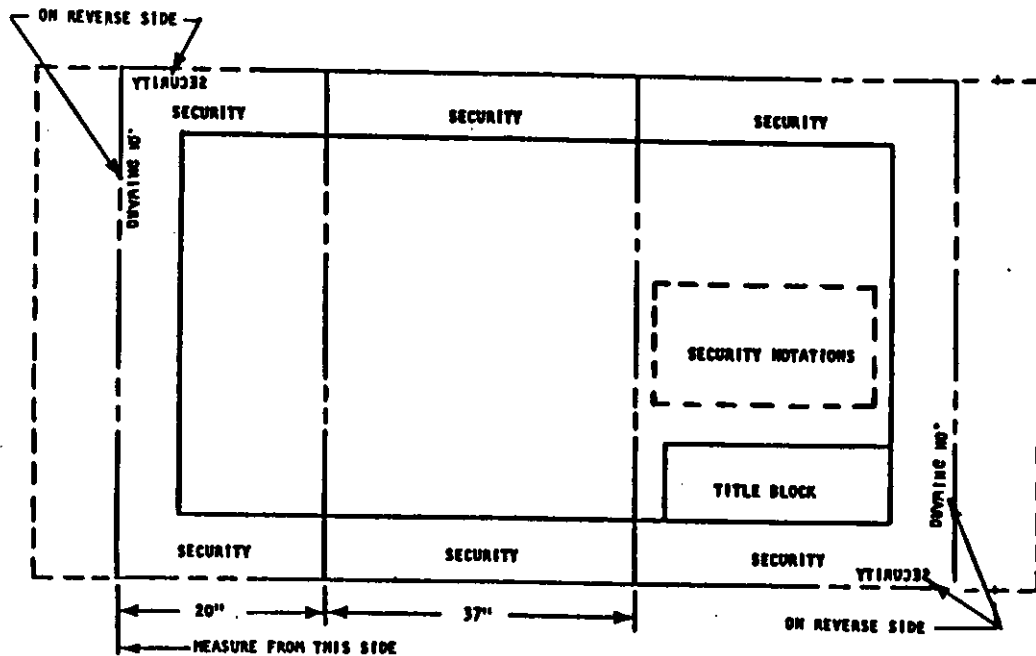

FIGURE B-2. Location of Security Markings on Roll Size Drawings

DOD-STD-00100D(AR)

B1.6 Location of Security Markings on Associated Lists. Security classification shall be centered outside the border at the top and bottom of the lists. Security notes shall be placed as shown on FIGURES B-3 and B-4.

FIGURE B-3. Location of Security Markings on Associated Lists

241

NO.	QTY	UNIT	DESCRIPTION	REMARKS	DATE	APPROVED
1	7669170	C	7669170	PLUG		
1	7669180	D	7669180	WASHER		
1	7669182	A	7669182	WASHER		
1	7669178	C	7669178	LENS, OBJECTIVE		
1	7669222	D	7669222	LENS, OBJECTIVE		
1	7669224	D	7669224	FILTER, 4000		
1	7669225	C	7669225	LENS, OBJECTIVE		
1	8279066	D	8279066	SHIELD		
1	8279062	D	8279062	SHIELD		
1	8279081	C	8279081	SCREW		
1	8279083	A	8279083	LENS, OPTICAL INSTRUMENT, OBJECTIVE		
1	8279086	A	8279086	LENS, OPTICAL INSTRUMENT, OBJECTIVE		
1	8279089	A	8279089	LENS, OPTICAL INSTRUMENT, OBJECTIVE		
1	8279080	D	8279080	SCREW		
1	8279081	A	8279081	PLUG		
1	8279020-0	C	8279020	CAP ASSEMBLY		
1	10513518	A	10513518	SCREW - HEX SOCKET, CAP POINT		1
1	10513556	D	10513556	SPACER		
1	10513557	D	10513557	SPACER		
1	10513558	D	10513558	RETAINER		
1	10513559	D	10513559	RETAINER		
1	10513560	B	10513560	RETAINER		
1	10513561	A	10513561	WASHER		
1	10513562	D	10513562	PLATE		
1	10513563	C	10513563	CELL		
1	10513564	C	10513564	POWDER, OBJECTIVE		
1	10513565	D	10513565	CELL, CEMENTED		1
1	10513566	D	10513566	SPACER		
1	10513567	D	10513567	PRISM, BOMBED		1
1	10513570	D	10513570	SPRING, COMPRESSION		
1	10513571	D	10513571	CONTACT		
1	10513572	C	10513572	SHIELD		
1	10513573	D	10513573	CELL ASSEMBLY		
1	10513582	C	10513582	SCREW, CEMENTED		2
1	10513583	D	10513583	SCREW		
1	10513583	C	10513583	SCREW		

FIGURE B-4. Location of Security Markings on Computer Generated Associated Lists

DOD-STD-00100D(AR)

B1.7 Location of Security Markings of Book-Form Drawings. Security markings shall be placed on pages containing classified information. Security notes shall be placed above the title block. Security classification shall be placed at top of pages. Place the following note on the cover sheet. **"COVER SHEET IS UNCLASSIFIED WHEN SEPARATED FROM SHEETS (List all Classified Sheet No.)."** See FIGURE B-5.

The figure consists of two diagrams illustrating the placement of security markings on drawing sheets.
 The left diagram shows a detailed drawing sheet layout. At the top, there is an 'APPLICATION' section with fields for 'REV. NO.', 'REV. BY', 'REV. DATE', 'REV. REASON', and 'REV. APPROVED'. Below this is a large 'CLASSIFICATION' box containing the text: 'REMOVED UNCLASSIFIED WHEN SEPARATED FROM SHEETS (LIST SHEET NO. OF CLASSIFIED SHEETS)'. Underneath the classification box is a revision table with columns for 'REV. NO.', 'REV. BY', 'REV. DATE', 'REV. REASON', and 'REV. APPROVED'. Below the table is a 'PART NO.' section with fields for 'PART NO.', 'DRAWING NUMBER', 'DRAWING TITLE', 'DESIGNED BY', 'CHECKED BY', 'DATE', 'SCALE', and 'SHEET'.
 The right diagram shows a simplified drawing sheet layout. It features a 'CLASSIFICATION' box at the top, followed by a 'SECURITY MARKINGS' section. At the bottom, there is a 'TITLE' section with fields for 'TITLE', 'REV.', 'CASE CODE', 'REVISION LEVEL', and 'SHEET'.

FIGURE B-5. Location of Security Markings on Book-Form Drawings

242

B1.8 Regrading Classification. Documents shall be regraded by lining out classification and related notes. The current classification shall be placed adjacent to the previous classification. The reclassification action constitutes a change; therefore, an applicable entry in the revision block in accordance with Chapter 500 is required. See FIGURE B-6.

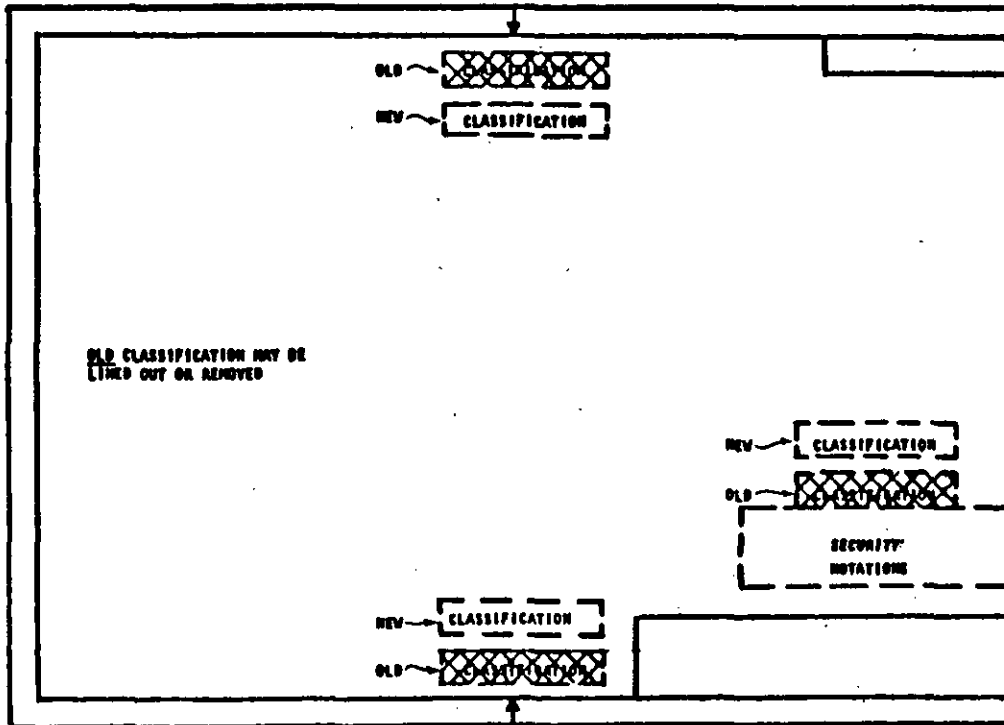

243

FIGURE B-6. Regrading Classification Location

DOD-STD-00100D(AR)

THIS PAGE LEFT BLANK INTENTIONALLY

244

DOD-STD-00100D(AR)

APPENDIX C
INTERPRETATION OF DIMENSIONING AND TOLERANCING

245

DESCRIPTION	ANSI Y14.5M-1982 SYMBOLS		SYMBOLS DESCRIPTION		SYMBOLS DESCRIPTION		SYMBOLS DESCRIPTION		SYMBOLS DESCRIPTION	
	MAX MATERIAL COND	REGARDLESS OF FEATURE SIZE	LEAST MATERIAL COND	DIAMETER	SPHERICAL DIAMETER	SPHERICAL RADIUS	BASIC DIMENSION	DATUM FEATURE	CONCENTRICITY	PERPENDICULARITY
CONCENTRICITY (COAXIALITY)	Ⓜ	Ⓜ	Ⓛ	Ⓛ	Ⓛ	Ⓛ	Ⓛ	Ⓛ	Ⓛ	Ⓛ
PERPENDICULARITY (SQUARENESS)	Ⓜ	Ⓜ	Ⓛ	Ⓛ	Ⓛ	Ⓛ	Ⓛ	Ⓛ	Ⓛ	Ⓛ
PARALLELISM	Ⓜ	Ⓜ	Ⓛ	Ⓛ	Ⓛ	Ⓛ	Ⓛ	Ⓛ	Ⓛ	Ⓛ
SYMMETRY	Ⓜ	Ⓜ	Ⓛ	Ⓛ	Ⓛ	Ⓛ	Ⓛ	Ⓛ	Ⓛ	Ⓛ
ANGULARITY	Ⓜ	Ⓜ	Ⓛ	Ⓛ	Ⓛ	Ⓛ	Ⓛ	Ⓛ	Ⓛ	Ⓛ
INTERRELATED CHARACTERISTICS (POSITION, PERPENDICULARITY, PARALLELISM, SYMMETRY, ANGULARITY AT RIGHT ANGLES TO COMMON AXIS)	Ⓜ	Ⓜ	Ⓛ	Ⓛ	Ⓛ	Ⓛ	Ⓛ	Ⓛ	Ⓛ	Ⓛ
FLATNESS	Ⓜ	Ⓜ	Ⓛ	Ⓛ	Ⓛ	Ⓛ	Ⓛ	Ⓛ	Ⓛ	Ⓛ
STRAIGHTNESS	Ⓜ	Ⓜ	Ⓛ	Ⓛ	Ⓛ	Ⓛ	Ⓛ	Ⓛ	Ⓛ	Ⓛ
POSITION (HOLES)	Ⓜ	Ⓜ	Ⓛ	Ⓛ	Ⓛ	Ⓛ	Ⓛ	Ⓛ	Ⓛ	Ⓛ
POSITION (SLOTS)	Ⓜ	Ⓜ	Ⓛ	Ⓛ	Ⓛ	Ⓛ	Ⓛ	Ⓛ	Ⓛ	Ⓛ
ROUNDNESS (RADIAL)	Ⓜ	Ⓜ	Ⓛ	Ⓛ	Ⓛ	Ⓛ	Ⓛ	Ⓛ	Ⓛ	Ⓛ
ROUNDNESS (DIAMETRAL)	Ⓜ	Ⓜ	Ⓛ	Ⓛ	Ⓛ	Ⓛ	Ⓛ	Ⓛ	Ⓛ	Ⓛ
PROJECTED TOL ZONE	Ⓜ	Ⓜ	Ⓛ	Ⓛ	Ⓛ	Ⓛ	Ⓛ	Ⓛ	Ⓛ	Ⓛ
PROFILE OF A LINE	Ⓜ	Ⓜ	Ⓛ	Ⓛ	Ⓛ	Ⓛ	Ⓛ	Ⓛ	Ⓛ	Ⓛ
PROFILE OF A SURFACE	Ⓜ	Ⓜ	Ⓛ	Ⓛ	Ⓛ	Ⓛ	Ⓛ	Ⓛ	Ⓛ	Ⓛ
RUNOUT (CIRCULAR)	Ⓜ	Ⓜ	Ⓛ	Ⓛ	Ⓛ	Ⓛ	Ⓛ	Ⓛ	Ⓛ	Ⓛ
RUNOUT (TOTAL)	Ⓜ	Ⓜ	Ⓛ	Ⓛ	Ⓛ	Ⓛ	Ⓛ	Ⓛ	Ⓛ	Ⓛ
CYLINDRICITY	Ⓜ	Ⓜ	Ⓛ	Ⓛ	Ⓛ	Ⓛ	Ⓛ	Ⓛ	Ⓛ	Ⓛ
POSITION (COMPOSITE FEATURE CONTROL SYMBOL)	Ⓜ	Ⓜ	Ⓛ	Ⓛ	Ⓛ	Ⓛ	Ⓛ	Ⓛ	Ⓛ	Ⓛ
RUNOUT (TWO DATUMS) (TWO DATUMS WITH COMMON AXIS)	Ⓜ	Ⓜ	Ⓛ	Ⓛ	Ⓛ	Ⓛ	Ⓛ	Ⓛ	Ⓛ	Ⓛ

RELATIONSHIP OF FEATURES (PERFECT FORM) FOR THE COMPLETE PART AT WHICH THE TOLERANCE IS APPLIED. THE ENTIRE SURFACE MUST BE WITHIN THE LIMITS, NOT MERELY A POINT ON THE SURFACE. THE MAX MATERIAL UNITS DEFINE A MAX PERMISSIBLE PROFILE FOR THE FEATURE AND THE MINIMUM UNITS DEFINE A MIN LIMIT OF SIZE. TOLERANCE IS ALLOWED WHEN THE FEATURE(S) DEPART FROM THE PERFECT FORM. A TOLERANCE POSITION AND FORM COMBINED IS ALLOWED EQUAL TO THE AMOUNT OF SUCH DEPARTURE. THE TOTAL PERMISSIBLE POSITION AND FORM IS MAXIMUM WHEN THE FEATURE IS AT THE POSITION AND FORM WITHIN THE TOLERANCE IS ALL BE CONTAINED WITHIN THE BONE.

3- USE OF THIS TABLE:
 BY COMBINING DRAWING REQUIREMENTS WITH THE TABLE AND LOCATING THE COMPARABLE GEOMETRIC TOLERANCE SYMBOL WITHIN THE TOLERANCE SYMBOL, THE APPLICABLE STANDARD FOR INTERPRETATION WOULD BE MIL-STD-88. IF MIL-STD-88 IS NOT AVAILABLE, THE REQUIREMENT CAN BE INTERPRETED USING ANSI Y14.5M-1982 BY USE OF THE GEOMETRIC TOLERANCE SYMBOL FOR MMC CONCENTRICITY.
 4- INTERPRETATION WHEN NO TOLERANCE OF FORM IS SPECIFIED:
 A. THE ENVELOPE OF PERFECT FORM AT MAXIMUM (MMC) AND LEAST (LMC) MATERIAL CONDITIONS APPLIES BOTH TO THE FEATURE AND TO THE BOUNDARY OF PERFECT FORM.

FIGURE C-1. Dimensioning and tolerancing matrix

246

DOD-STD-00100D(AR)

APPENDIX D
SAMPLE DRAWINGS

447

DOD-STD-00100D(AR)

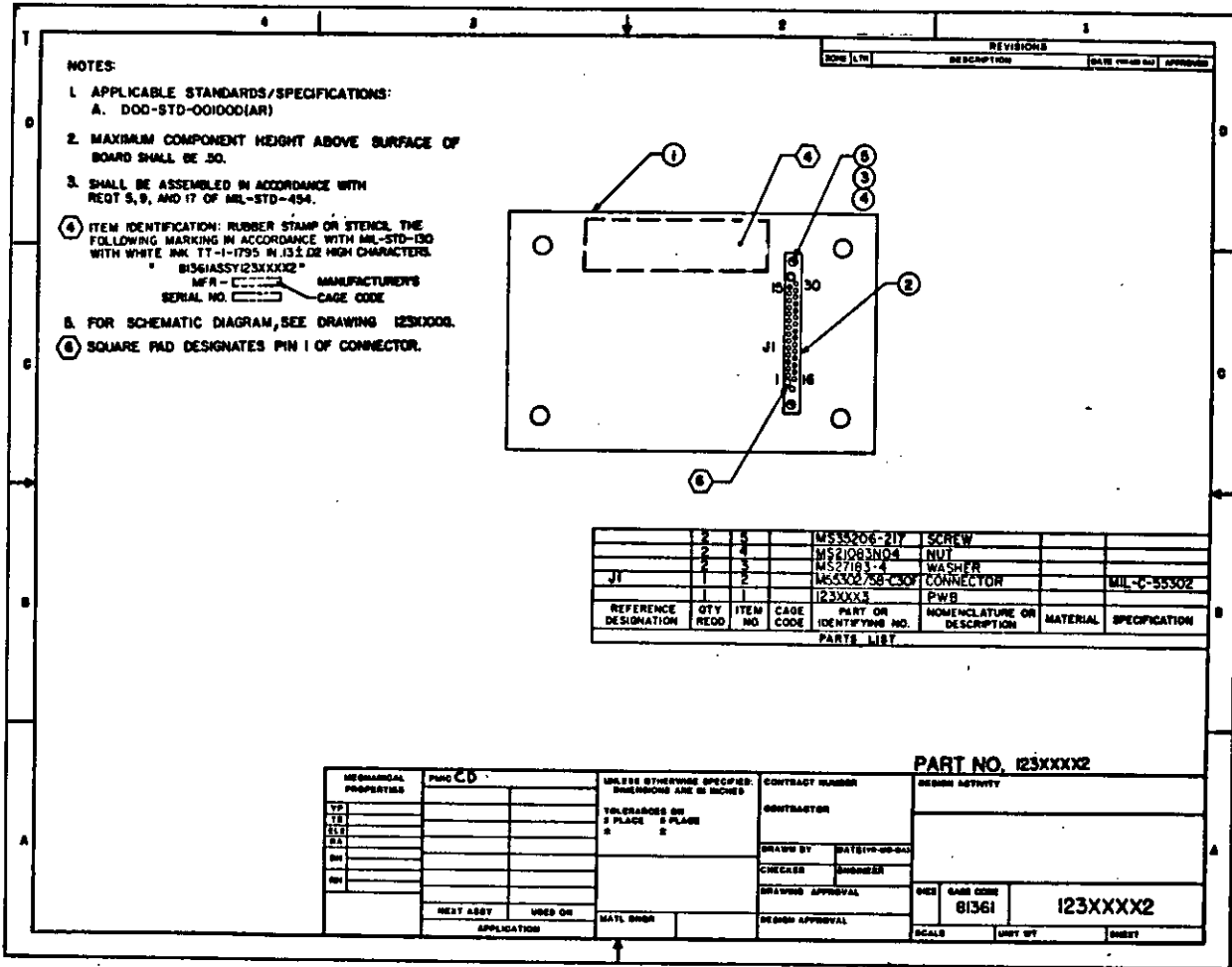

FIGURE D-2. Assembly (with Find Numbers)

This sample drawing is informational only and complete to the degree necessary to illustrate a type of drawing. Actual format and drawing shall conform to the textual requirements set forth in this standard.

DOD-STD-00100D(AR)

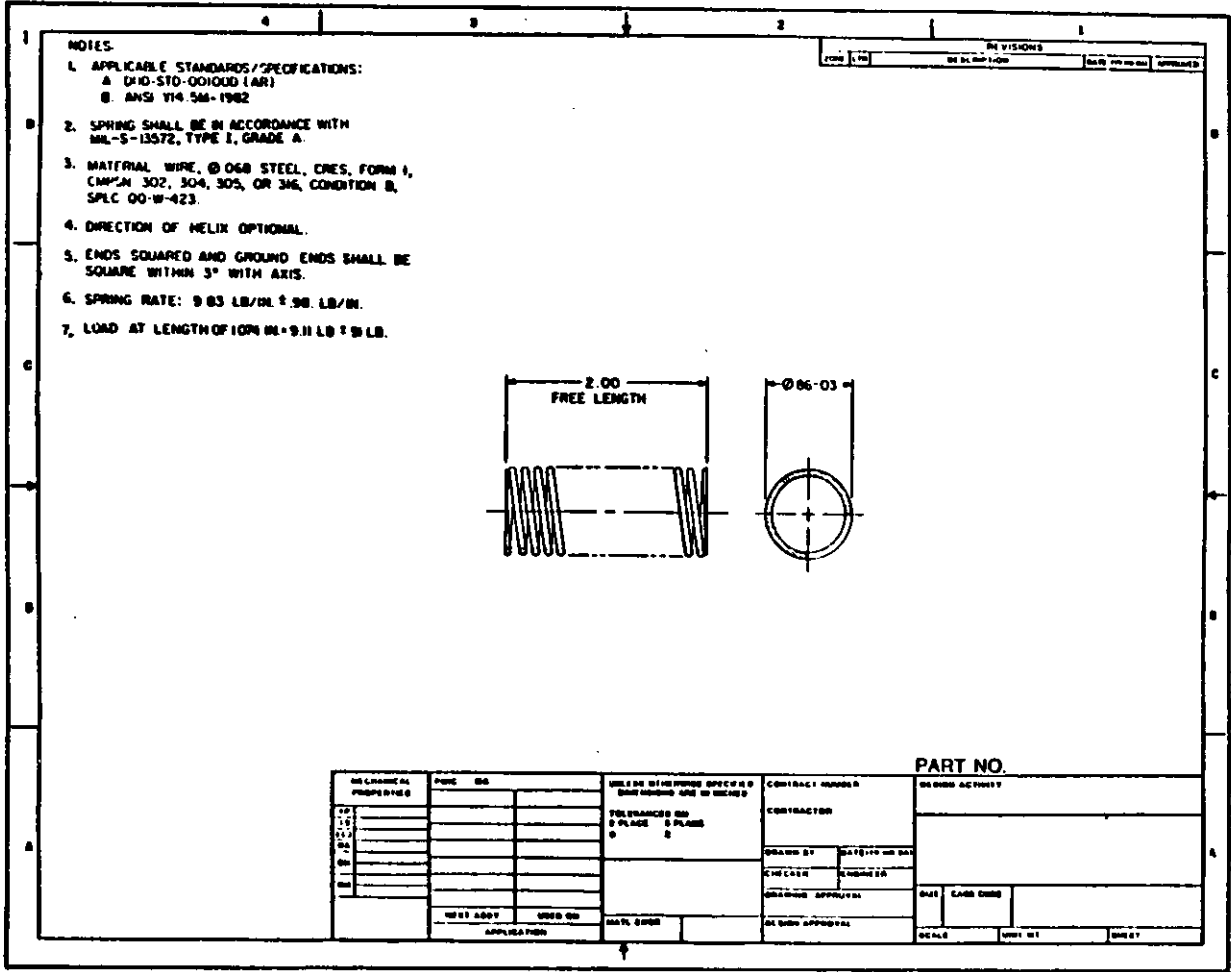

FIGURE D-3. Spring, Compression

This sample drawing is informational only and complete to the degree necessary to illustrate a type of drawing. Actual format and drawing shall conform to the textual requirements set forth in this standard.

DOD-STD-00100D(AR)

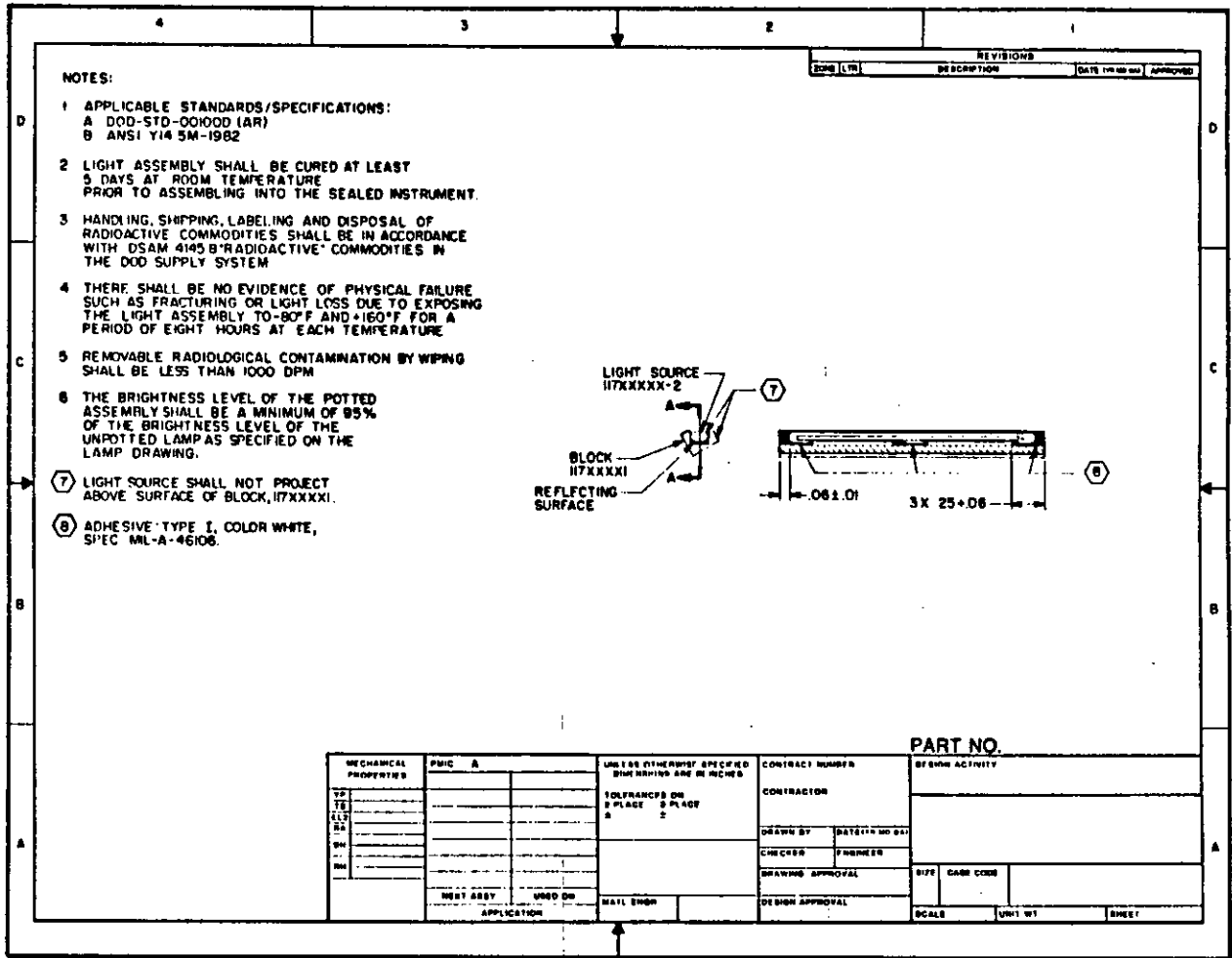

FIGURE D-5. Radioactive material drawing

This sample drawing is informational only and complete to the degree necessary to illustrate a type of drawing. Actual format and drawing shall conform to the textual requirements set forth in this standard.

DOD-STD-00100D(AR)

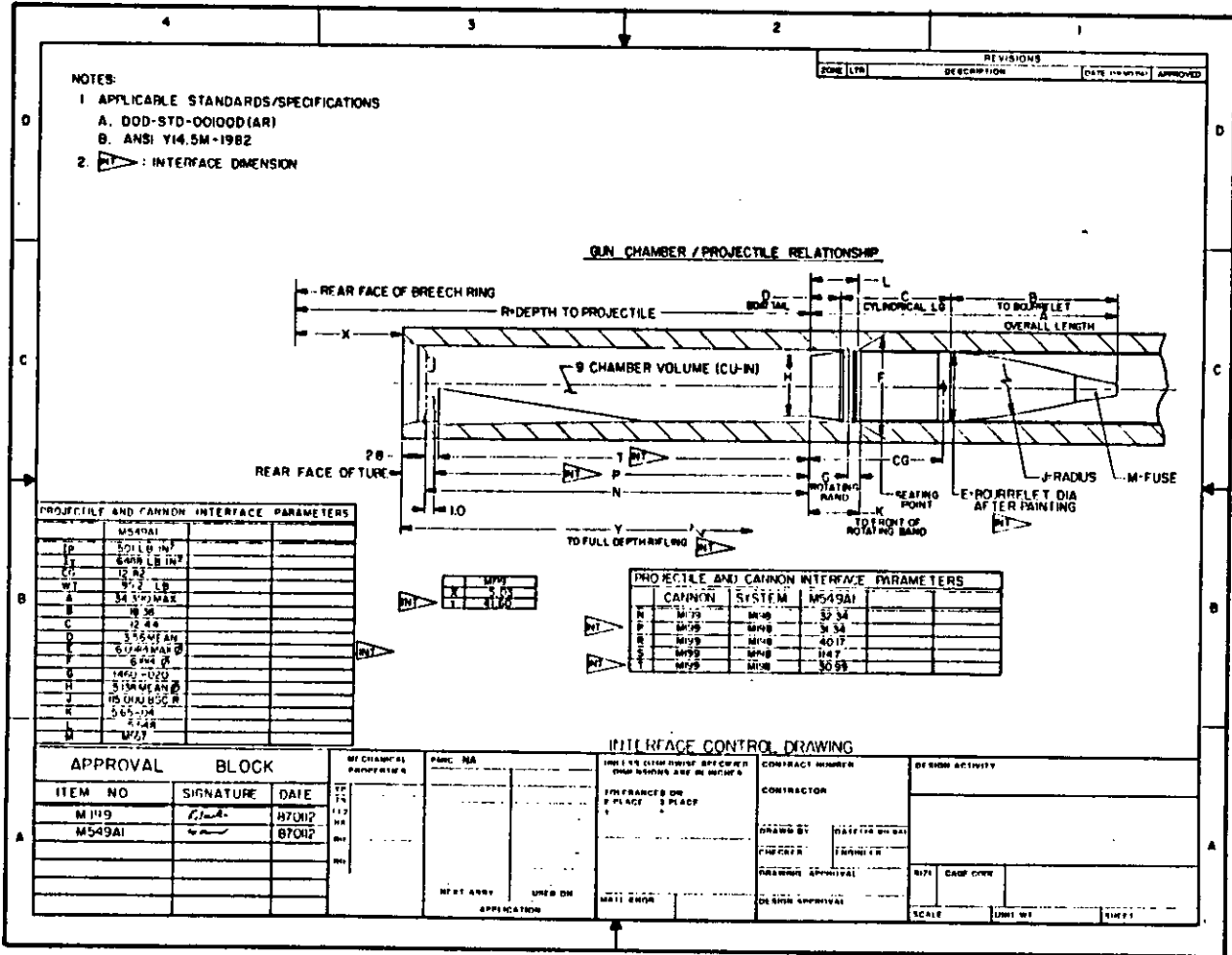

FIGURE D-6. Interface control drawing

This sample drawing is informational only and complete to the degree necessary to illustrate a type of drawing. Actual format and drawing shall conform to the textual requirements set forth in this standard.

DOD-STD-00100D(AR)

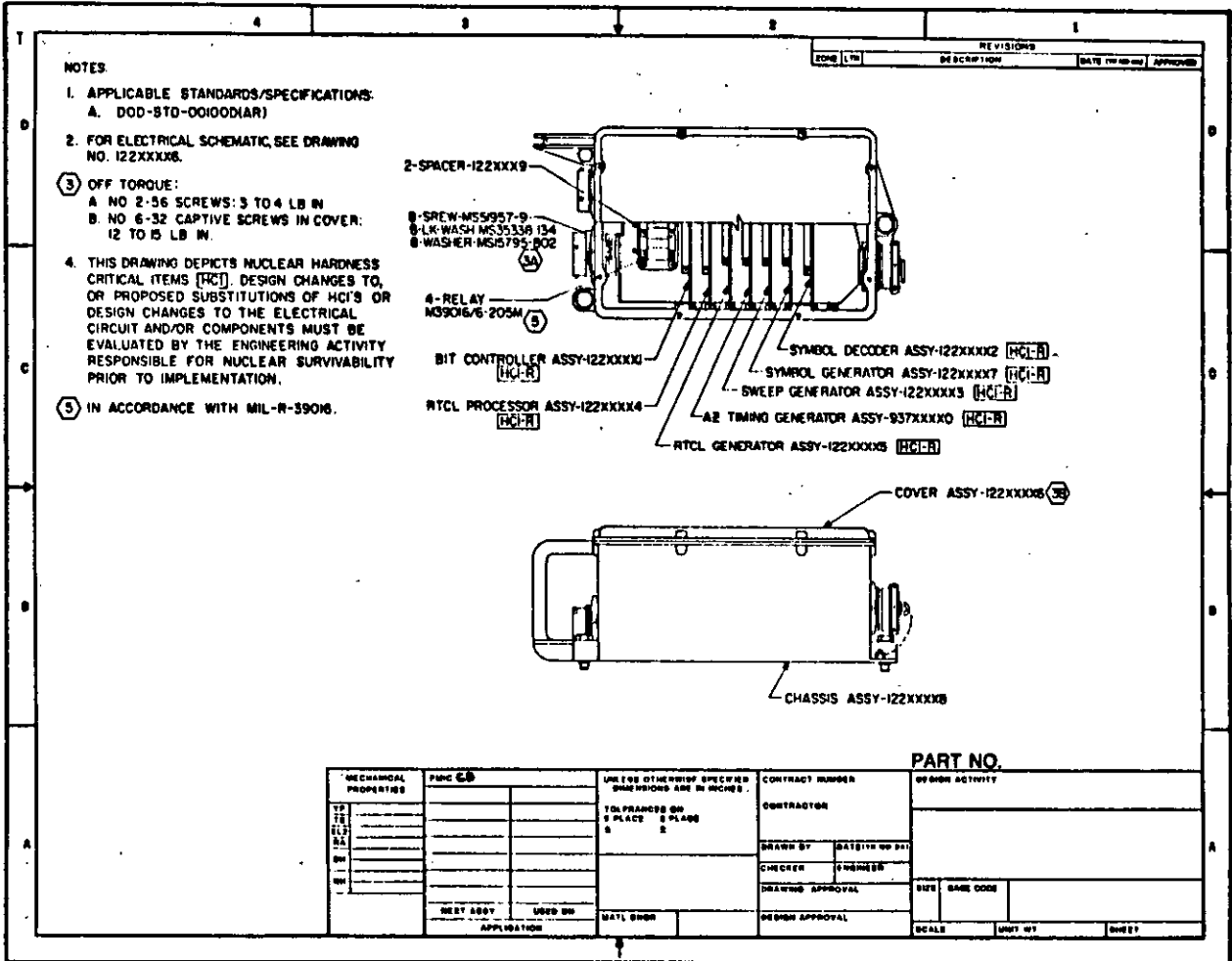

FIGURE D-7. Electronic Assembly (with Hardness Critical Items)

This sample drawing is informational only and complete to the degree necessary to illustrate a type of drawing. Actual format and drawing shall conform to the textual requirements set forth in this standard.

DOD-STD-00100D(AR)

1		4		3		2		1	
REF DES	PART NO. OR TYPE DESIGNATOR	SPEC NO.	REMARKS	NO. REQ'D	REF DES	PART NO. OR TYPE DESIGNATOR	SPEC NO.	REMARKS	NO. REQ'D
R04, R02	RNC504002FM		10K	2	R17, R02	HTXXXXX-8		1.04K	2
R21, R22	1003FM		100K	2	R20	-19		3.01K	1
R06	133FM		1.33K	1	R01	-103		Y3.2K	1
R08	143FM		1.43K	1	R30	-34		10K	1
R40, R40, R02	2002FM		20K	7	R30	-42		15.00K	1
R03, R02, R07									
R41, R42, R60					R3, R12			50K	15
R05, R03, R03	2003FM		200K	8	R10, R10, R00			1/10W 2 00%	
R14	222FM	ML-N-2002/1	22.2K	1/10W	R0, R02, R00				
R33	262FM		26.1K	1/10	R00, R00, R00	-63			
R24	267FM		26.7K	1	R00, R00				
R55	3092FM		30.9K	1	R20, R21, R30			100K	
R31	332FM		33.2K	1	R33, R72, R73	-67			0
					R00, R04				
R50, R10	492FM		49.2K	2	R1, R00, R20				
R04, R10	634FM		6.34K	2	R07, R10, R10	HTXXXXX-70		200K	6
R00, R102	6652FM		66.5K	2					
R120	7502FM		75K	1					
R26	820FM		82K	1					
R74	866FM		86K	1					
R24	978FM		97K	1					
R23	FM		FM	1					
R20	FM		FM	1					
R00	3572FM		35.7K	1					
R20	RNC5040030M		200K	1/10W					
R32	RNC6042403FM		249K	1/10W					
R00	RNC604003FM	ML-N-2002/1	400K	1/10					

MECHANICAL PROPERTIES		P/NQ ID		UNLESS OTHERWISE SPECIFIED, DIMENSIONS ARE IN INCHES		CONTACT NUMBER		SERIES ACTIVITY	
TP				TOLERANCES UNLESS OTHERWISE SPECIFIED		CONTRACTOR			
EL				FRACTIONS 2 PLACES 2 PLACES		DRAWN BY		DATE	
DL				DECIMALS 2 PLACES 2 PLACES		CHECKED BY		NUMBER	
SH						DRAWING APPROVAL		REV	
SN						SERIES APPROVAL		DATE	
BEST COPY		JOB NO		DATE ENGR		SERIES APPROVAL		SCALE	
APPLICATION								UNIT WT	
								INCHES	

FIGURE D-8. Apparatus List

This sample drawing is informational only and complete to the degree necessary to illustrate a type of drawing. Actual format and drawing shall conform to the textual requirements set forth in this standard.

DOD-STD-00100D (AR)

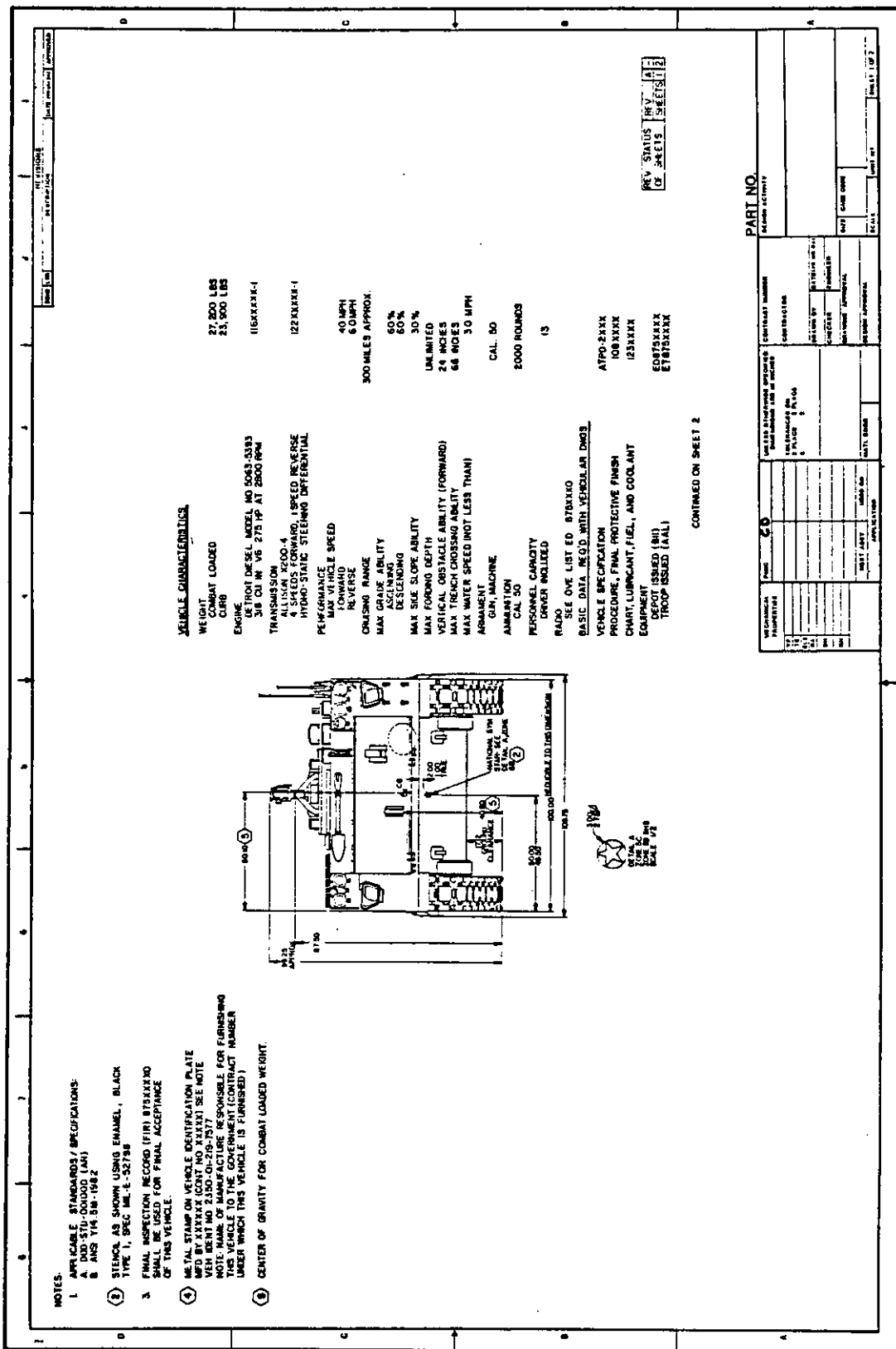
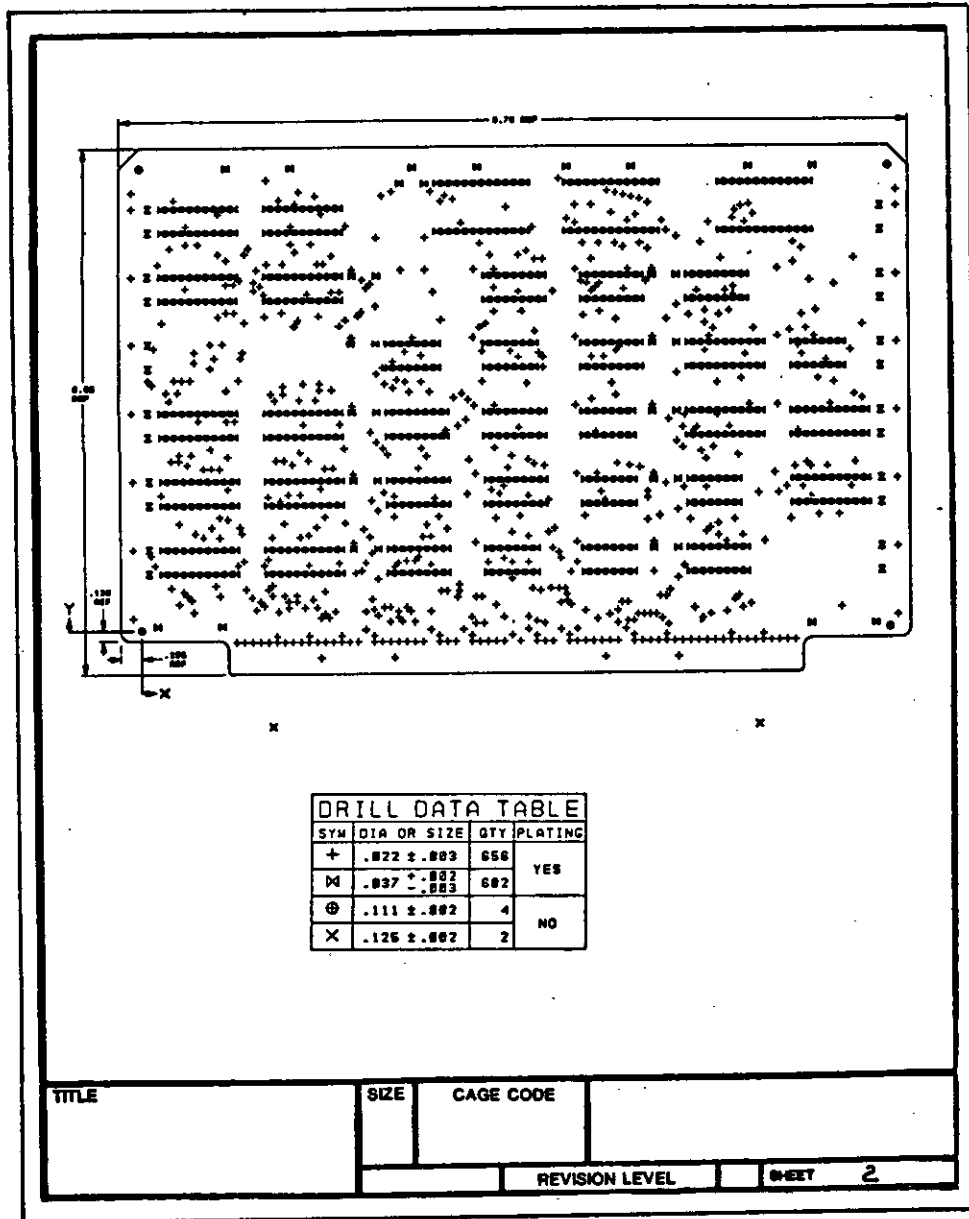

FIGURE D-9. Vehicle drawing (top assembly)

This sample drawing is informational only and complete to the degree necessary to illustrate a type of drawing. Actual format and drawing shall conform to the textual requirements set forth in this standard.

DOD-STD-00100D(AR)



DRILL DATA TABLE				
SYM	DIA OR SIZE	QTY	PLATING	
+	.022 ± .003	656	YES	
M	.037 ± .003	682	YES	
⊕	.111 ± .002	4	NO	
X	.125 ± .002	2	NO	

FIGURE D-11. Printed wiring hole location drawing (Cont'd)

This sample drawing is informational only and complete to the degree necessary to illustrate a type of drawing. Actual format and drawing shall conform to the textual requirements set forth in this standard.

DOD-STD-00100D(AR)

SIZE		SIZE		SIZE		SIZE		SIZE		SIZE	
H	Y	H	Y	H	Y	H	Y	H	Y	H	Y
2000	4000	5425	8000	4125	4475	4475	-75	5425	125	4225	750
2025	1150	5475	-150	4175	-150	4475	140	5475	1625	4275	1075
2050	575	5475	1150	4200	400	4475	5700	5475	2450	4325	1325
2075	950	5475	2200	4250	8750	4475	4800	5475	4250	4350	8775
2090	4300	5475	3075	4250	4000	4475	475	5475	-125	4375	2625
2100	1000	5475	3400	4275	75	4475	5425	5475	1700	4375	4475
2125	8450	5475	3400	4275	9075	4475	-150	5475	3900	4350	175
2150	4300	5475	1200	4275	3075	4475	75	5475	4300	4350	1000
2175	-150	5475	2150	4275	8450	4475	3200	5475	-250	4350	1400
2175	75	5475	2225	4275	8900	4475	3025	5475	4000	4350	600
2175	200	5475	4475	4275	5450	4475	3700	5475	125	4350	1400
2175	175	5475	0	4275	-150	4475	3375	5475	1500	4350	125
2175	825	5475	275	4275	825	4475	4000	5475	3375	4350	9075
2175	925	5475	900	4275	8000	4475	1800	5475	-150	4375	-150
2200	2325	5475	1100	4275	1725	4475	1600	5475	175	4375	-75
2200	3175	5475	8900	4275	4050	4475	5050	5475	3450	4375	600
2200	4425	5475	3450	4275	-150	4475	5075	5475	3000	4375	1500
2225	4375	5475	1625	4275	300	4475	1000	5475	9175	4350	50
2225	5425	5475	4200	4275	1275	4475	1250	5475	-150	4350	2000
2425	8725	5475	-150	4275	2750	4475	4200	5475	75	4300	4900
2475	-150	5475	75	4275	2375	4475	500	5475	225	4325	475
2500	275	5475	1400	4275	2900	4475	1150	5475	2000	4325	2000
2500	1700	5475	475	4275	4250	4475	0	5475	2000	4375	-150
2500	3250	5475	-150	4275	4250	4475	900	5475	2000	4375	600
2500	5450	5475	475	4275	1875	4475	525	5475	3450	4375	2000
2525	2050	5475	475	4275	-150	4475	500	5475	3450	4375	2000
2550	2250	5475	5225	4275	8500	4475	475	5475	3450	4375	2000
2550	3250	5475	8000	4275	1875	4475	8000	5475	4000	4375	1475
2575	-150	5475	2775	4275	150	4475	350	5475	325	4375	5175
2575	100	5475	3400	4275	875	4475	425	5475	3000	4375	400
2575	275	5475	150	4275	1775	4475	-150	5475	0	4375	475
2125	2000	5475	100	4275	2000	4475	-75	5475	4225	4375	-150
2125	1000	5475	3075	4275	825	4475	6100	5475	4700	4375	775
2125	775	5475	2475	4275	-75	4475	300	5475	8400	4375	1750
2125	1400	5475	400	4275	825	4475	700	5475	100	4375	2250
2125	1950	5475	475	4275	625	4475	-150	5475	225	4375	2000
2125	2000	5475	800	4275	1200	4475	525	5475	2025	4375	2525
2125	2325	5475	825	4275	2150	4475	825	5475	4475	4375	-150
2125	3450	5475	5500	4275	2450	4475	1875	5475	9075	4375	1250
2175	-150	5475	6500	4275	-150	4475	1825	5475	-150	4375	3000
2175	150	5475	0	4275	1400	4475	1275	5475	-75	4375	50
2175	825	5475	2925	4275	2500	4475	3625	5475	100	4375	2400
2175	925	5475	5050	4275	3275	4475	4475	5475	925	4375	-150
2175	5100	5475	1675	4275	4200	4475	5050	5475	175	4375	2000
2225	100	5475	2600	4275	4850	4475	5275	5475	8125	4375	4200
2225	4475	5475	2100	4275	3900	4475	4225	5475	1100	4375	125
2275	-150	5475	4450	4275	0	4475	-150	5475	-150	4375	2200
2275	275	5475	150	4275	150	4475	225	5475	4000	4375	4000
2275	850	5475	-75	4275	825	4475	1400	5475	5250	4375	150
2275	3075	5475	100	4275	1150	4475	2900	4200	175	4375	1250
2275	5450	5475	8000	4275	1450	4475	4000	4250	1950	4375	1500
2325	225	5475	9050	4275	2100	4475	4300	5250	1825	4375	2100
2325	2000	5475	75	4275	2050	4475	-150	5475	1700	4375	3450
2375	-150	5475	400	4275	1700	4475	2850	5475	425	4375	6000
2375	100	5475	1075	4275	300	4475	3275	5475	-150	4375	2925
2375	800	5475	1925	4275	4050	4475	4200	5475	175	4375	175
2375	925	5475	2775	4275	4800	4475	4800	5475	475	4375	150
2425	900	5475	2625	4275	-150	4475	8275	4275	5000	4375	2625

TITLE	SIZE	CAGE CODE	
		REVISION LEVEL	SHEET 3

FIGURE D-11. Printed wiring hole location drawing (Cont'd)

This sample drawing is informational only and complete to the degree necessary to illustrate a type of drawing. Actual format and drawing shall conform to the textual requirements set forth in this standard.

260

DOD-STD-00100D(AR)

.002		.002		.002		.002		.002		.002	
X	Y	X	Y	X	Y	X	Y	X	Y	X	Y
7070	100	6070	9000	100	700	070	1000	1170	4400	2070	1350
7070	-100	6070	8900	100	1000	070	2000	1170	4900	2070	1850
7070	2000	6070	4000	100	1500	070	2700	1170	5200	2070	2100
7070	3725	6170	2450	100	1800	070	3100	1070	700	2070	2700
7100	1100	6170	2900	100	2000	070	3400	1070	1000	2070	3100
7100	1200	6170	1700	100	2700	070	4000	1070	1500	2070	4000
7100	2000	6170	3400	100	3200	070	5200	1070	1800	2070	4900
7100	2000	6170	2900	100	3600	070	700	1070	2400	2070	5200
7100	2000	6170	4725	100	4100	070	1000	1070	2700	2170	700
7170	-100	6270	2000	100	4400	070	1500	1070	3100	2170	1000
7170	6000	6270	3725	100	4900	070	1800	1070	4000	2170	1500
7220	200	6270	1825	100	5200	070	2400	1070	4900	2170	1900
7220	1070	6270	2000	090	50	070	2700	1070	5200	2170	2400
7220	4000	6270	4225	070	900	070	4100	1070	700	2170	2700
7270	-100	6270	6025	070	1000	070	4400	1070	1000	2170	4100
7270	-75	6250	8900	070	1500	070	4900	1070	1350	2170	4400
7270	2000	6270	1400	070	1800	070	5200	1070	1900	2170	4900
7270	2000	6370	3100	070	2400	070	700	1070	2400	2170	5200
7270	2000	6470	2000	070	2700	070	1000	1070	2700	2270	700
7270	1300	6470	3325	070	4100	070	1500	1070	4100	2270	1000
7320	4100	6570	2770	070	4400	070	1800	1070	4400	2270	1500
7320	4200	6570	3000	070	4900	070	2400	1070	4900	2270	1900
7320	5100	6570	4270	070	5200	070	2700	1070	5200	2270	2400
7360	8200	6670	1400	070	700	070	4100	1070	700	2270	2700
7370	-100	6650	200	070	1000	070	4400	1070	1000	2270	4100
7370	400	6770	1700	070	1500	070	4900	1070	1500	2270	4400
7370	2100	6770	2400	070	1800	070	5200	1070	1800	2270	4900
7420	900	6870	2900	070	2000	070	2700	1070	2400	2270	5200
7420	1100	6870	2900	070	2700	070	1800	1070	2700	2270	700
7420	3100	6870	4400	070	4100	070	1500	1070	4100	2270	1000
7420	3050	6970	2800	070	4400	070	1800	1070	4400	2270	1500
7470	100	6970	2770	070	4900	070	2400	1070	4900	2270	1900
7470	3000	6950	180	070	5200	070	2700	1070	5200	2270	2400
7470	3000	7050	1000	070	700	070	4100	1070	700	2270	2700
7470	300	7050	1800	070	1000	070	4400	1070	1000	2270	4100
7470	2770	7050	2700	070	1500	070	1800	1070	1500	2270	4400
7470	2870	7050	3900	070	1800	070	2200	1070	1900	2270	4900
7470	-100	7050	4400	070	2400	070	1000	1070	2400	2270	5200
7470	870	7050	8200	070	2700	1070	700	1070	2700	2470	700
7470	8100	7050	4100	070	4100	1070	1800	1070	4100	2470	1000
7470	1070	7050	4400	070	4400	1070	1500	1070	4400	2470	1500
7470	-100	7050	4900	070	4900	1070	1800	1070	4900	2470	1900
7470	1070	7050	5200	070	5200	1070	2400	1070	5200	2470	2400
7470	1070	7050	2800	070	700	1070	2700	1070	5700	2470	2700
7470	-100	7050	1000	070	1000	1070	4100	1070	700	2470	4100
7470	1800	7050	1800	070	1500	1070	4400	1070	1000	2470	4400
7470	1870	7050	2800	070	1800	1070	4900	1070	1500	2470	4900
7470	1870	7050	3700	070	2400	1070	5200	1070	1800	2470	5200
7470	1870	7050	4100	070	2700	1070	700	1070	2700	2620	1900
7470	4470	7050	4400	070	4000	1070	1500	1070	4100	2620	2700
7470	-100	7050	8900	070	4900	1070	1800	1070	4600	2620	3900
7470	1700	7050	1200	070	5200	1070	2200	1070	4900	2620	4400
8020	1200	670	700	1170	2400	1070	2700	1070	3700	2800	1000
8020	2700	670	1800	1170	2700	1070	700	1070	4200	2800	1800
8070	-100	670	1800	1170	4100	1070	1000	1070	4700	2800	2700

TITLE	SIZE	CAGE CODE	
		REVISION LEVEL	SHEET 4

FIGURE D-11. Printed wiring hole location drawing (Cont'd)

This sample drawing is informational only and complete to the degree necessary to illustrate a type of drawing. Actual format and drawing shall conform to the textual requirements set forth in this standard.

DOD-STD-00100D(AR)

SIZE - .007		SIZE - .007		SIZE - .007		SIZE - .007		SIZE - .007		SIZE - .007	
X	Y	X	Y	X	Y	X	Y	X	Y	X	Y
7275	3250	0175	1000	0100	1000						
7275	3000	0175	2000	0100	1500						
7275	4100	0175	2700	0100	2000						
7275	4400	0175	3200	0100	2700						
7275	4800	0175	3600	0100	3200						
7275	5050	0175	4000	0100	3500						
7275	700	0175	4500	0100	4000						
7275	1000	0175	5000	0100	4500						
7275	1500	0275	1000	0100	4800						
7275	1500	0275	1500	0100	5000						
7275	2000	0275	2000								
7275	2700	0275	2700								
7275	2900	0275	3200								
7275	3050	0275	3500								
7275	4100	0275	4000								
7275	4400	0275	4500								
7275	4900	0325	0700								
7275	5000	0375	1000								
7475	700	0275	1500								
7475	1000	0275	2000								
7475	2400	0275	2700								
7475	2700	0275	3200								
7475	2850	0275	3500								
7475	3050	0475	1000								
7475	3100	0475	1500								
7475	4400	0475	2000								
7475	4900	0475	2700								
7475	5100	0475	3200								
7475	5700	0475	3500								
7575	2000	0675	1000								
7575	2700	0675	1500								
7575	3200	0675	2000								
7575	3800	0675	2700								
7575	4300	0675	3200								
7575	5000	0675	3500								
7575	2400	0675	1000								
7575	2700	0675	1500								
7575	3200	0675	2000								
7575	3900	0675	2700								
7575	4500	0675	3200								
7775	4000	0775	1500								
7775	5000	0775	1500								
7875	4900	0775	2000								
7875	5000	0675	1000								
7875	5000	0675	1500								
8075	1000	0575	3000								
8075	2400	0675	2700								
8075	2700	0675	1500								
8075	3200	0675	2000								
8075	3600	0675	2700								
8075	4000	0675	3000								
8075	5000	0100	700								
0175	1000	0100	1000								

TITLE		SIZE	CAGE CODE	
			REVISION LEVEL	SHEET 6

263

FIGURE D-11. Printed wiring hole location drawing (Cont'd)

This sample drawing is informational only and complete to the degree necessary to illustrate a type of drawing. Actual format and drawing shall conform to the textual requirements set forth in this standard.

DOD-STD-00100D(AR)

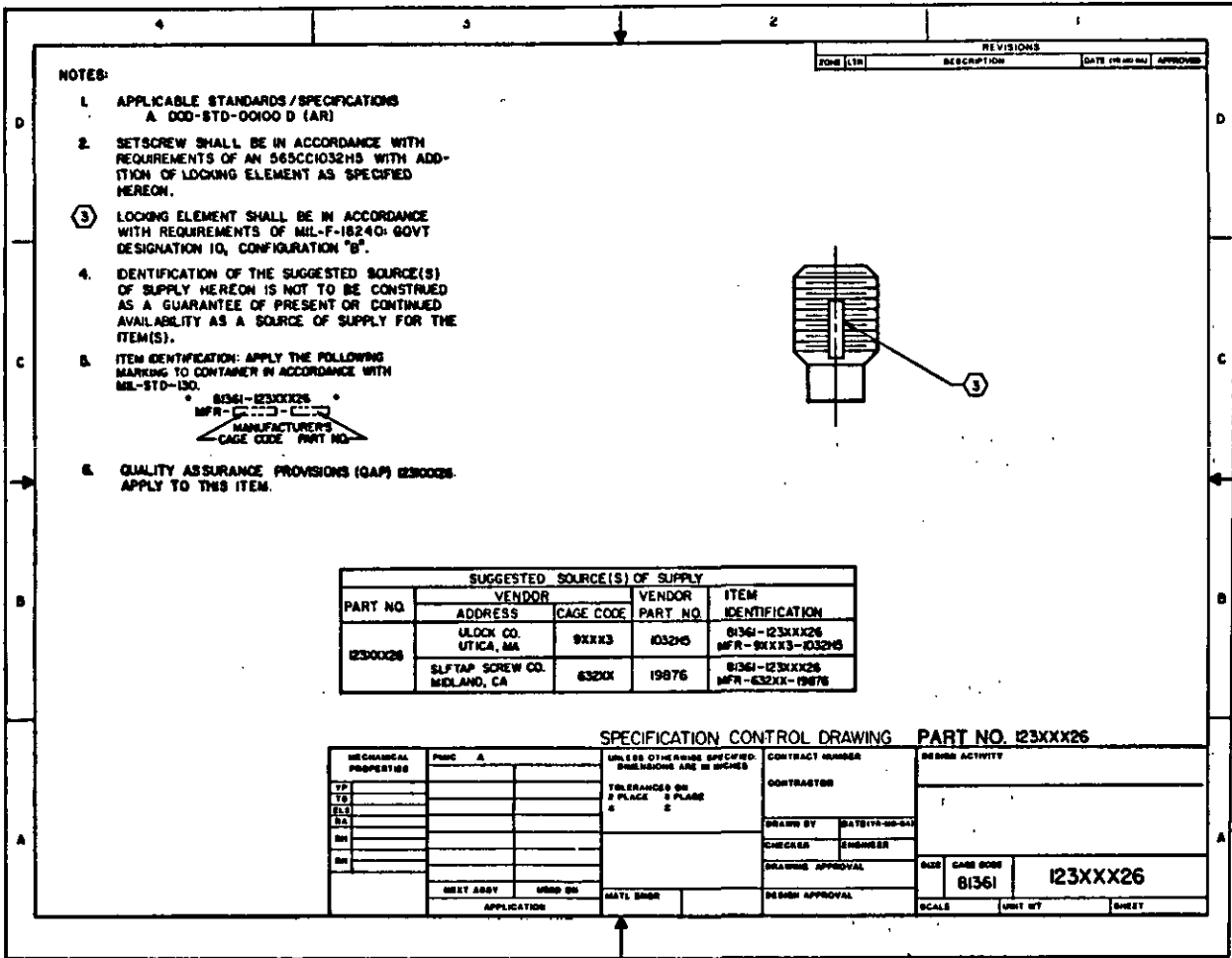

FIGURE D-13. Specification control drawing

This sample drawing is informational only and complete to the degree necessary to illustrate a type of drawing. Actual format and drawing shall conform to the textual requirements set forth in this standard.

DOD-STD-00100D(AR)

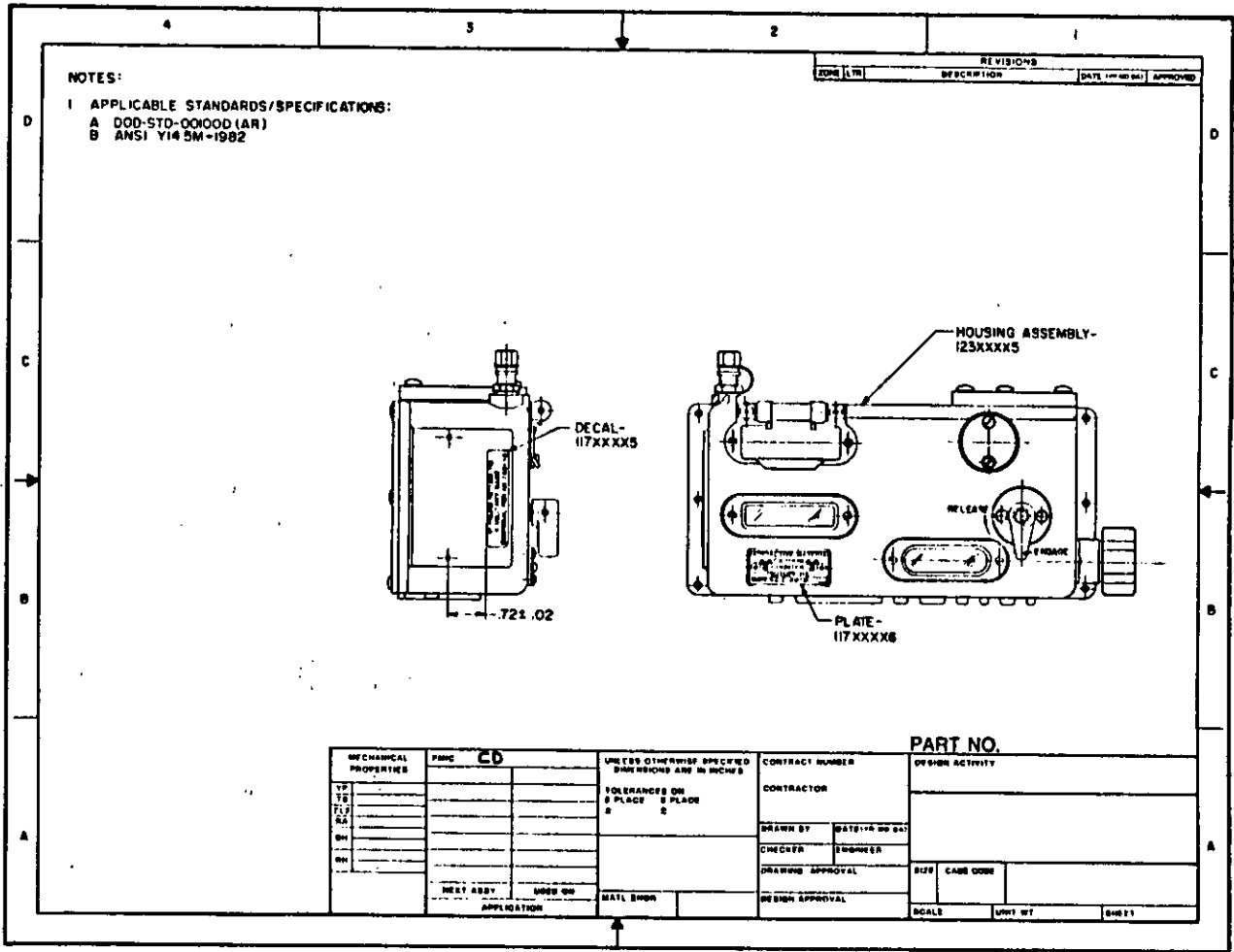

FIGURE D-14. Radioactive assembly drawing

This sample drawing is informational only and complete to the degree necessary to illustrate a type of drawing. Actual format and drawing shall conform to the textual requirements set forth in this standard.

266

DOD-STD-00100D(AR)

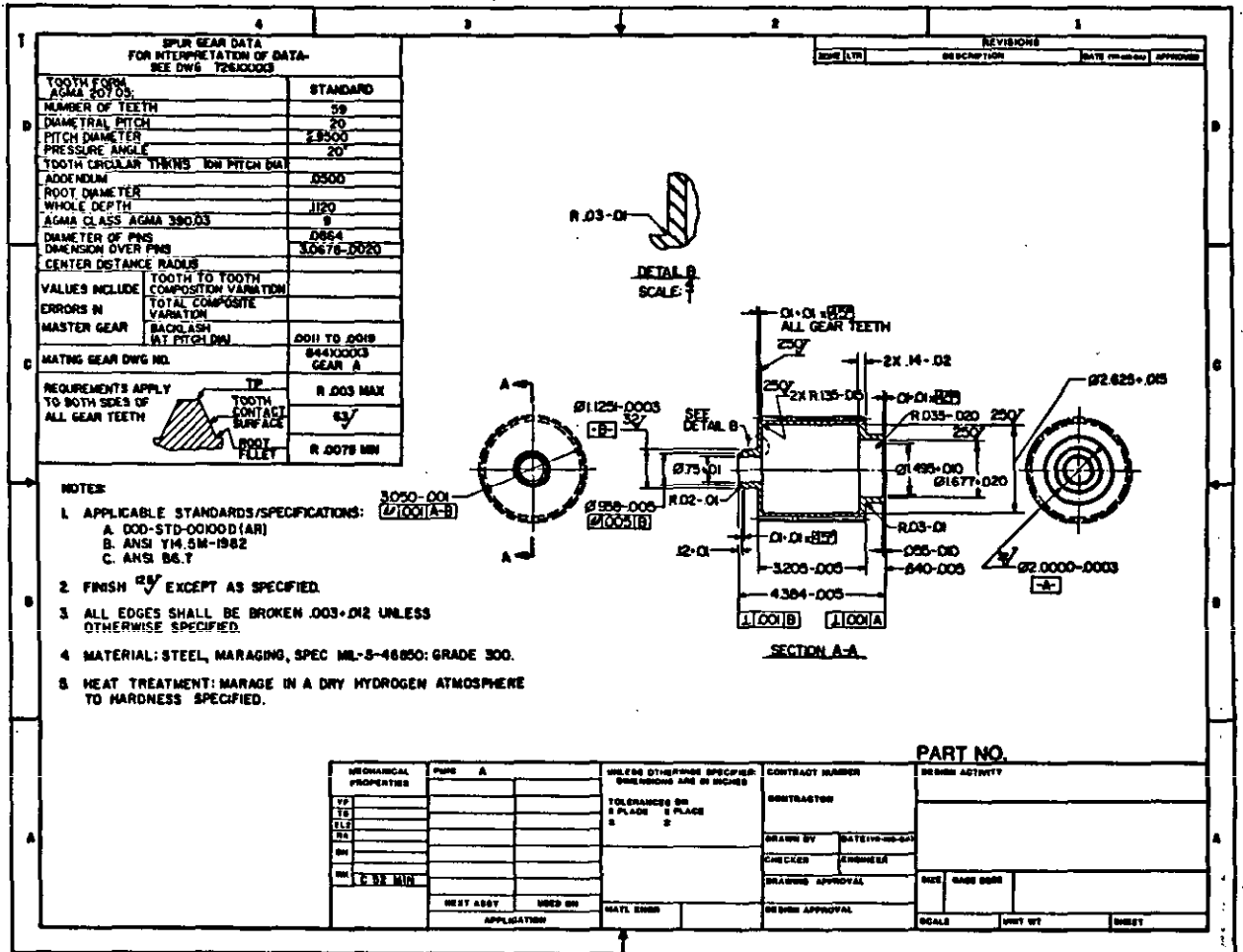

FIGURE D-16. Spur Gear Data Drawing

This sample drawing is informational only and complete to the degree necessary to illustrate a type of drawing. Actual format and drawing shall conform to the textual requirements set forth in this standard.

DOD-STD-00100D(AR)

NOTES		REVISIONS																																												
		CODE	DATE	DESCRIPTION	APPROVED																																									
<p>1. SCOPE: THIS DRAWING DEFINES THE GENERAL REQUIREMENTS FOR SURFACE HARDENING CORROSION RESISTANT STEELS, PRECIPITATION HARDENING STEELS AND HIGH TEMPERATURE ALLOYS BY NITRIDING METHODS.</p> <p>2. CLASSIFICATION: CLASS A NITRIDING OF THE COMPONENTS FOR WHICH A CASE DEPTH OF MORE THAN .001 INCH IS REQUIRED. CLASS B NITRIDING OF THE COMPONENTS FOR WHICH A CASE DEPTH OF .001 INCH OR LESS IS REQUIRED.</p> <p>3. GENERAL: A. UNLESS OTHERWISE SPECIFIED, NITRIDING OF THE COMPONENT SHALL BE ACCOMPLISHED AFTER: (1) ALL MACHINING, FORMING, WELDING OPERATIONS HAVE BEEN COMPLETED. (2) COMPONENT HAS BEEN APPROPRIATELY HEAT TREATED TO PROVIDE REQUIRED CORE PROPERTIES. (3) COMPONENT SURFACES HAVE BEEN CONDITIONED TO REMOVE ALL TENACIOUS OXIDES. B. THE EQUIPMENT USED SHALL BE IN ACCORDANCE WITH EQUIPMENT REQUIREMENTS SPECIFIED IN SPEC MIL-9-6090. C. CARE SHALL BE EXERCISED TO PREVENT THE INTRODUCTION OF CARBON OR OTHER CONTAMINANTS DURING THE NITRIDING PROCESS.</p> <p>4. PROCEDURES: NITRIDING IS THE PROCESS OF HARDENING THE SURFACES OF THE COMPONENTS BY:</p>	<p>A. FOR CLASS A: HEATING THE COMPONENT IN SPECIAL FURNACES IN WHICH CRACKED AMMONIA IS CIRCULATED AND THEN COOLING THE COMPONENT IN THE FURNACE.</p> <p>B. FOR CLASS B: IN ACCORDANCE WITH AMS2755. PREHEATING THE COMPONENT TO REMOVE WATER AND REDUCE THERMAL SHOCK THEN IMMERSING IN AN AERATED CYANIDE- CYANATE MOLTEN SALT BATH AND THE QUENCHING IN WATER OR OIL.</p> <p>B. PRODUCT REQUIREMENTS: A. THE REQUIREMENTS SPECIFIED ON THE COMPONENT DRAWING ARE DEPENDENT ON: (1) NITRIDE CLASS. THE CLASS IS DETERMINED BY THE DESIRED CASE THICKNESS. (2) BASIC CORE HARDENING TEMPERATURE: THE MAXIMUM NITRIDING TEMPERATURE SHOULD BE 25F BELOW THE MINIMUM SPECIFIED CORE HARDENING TEMPERATURE. (3) SURFACE HARDNESS OF THE NITRIDED COMPONENT. B. FOR CLASS A NITRIDE, THE FOLLOWING SHALL BE SPECIFIED AS COMPONENT DRAWING REQUIREMENTS. (1) NITRIDING TEMPERATURE WITH A TOLERANCE OF 50F. (2) TOTAL CASE DEPTH. (3) SURFACE HARDNESS. C. FOR CLASS B NITRIDE, THE APPLICABLE MATERIAL AS LISTED IN AMS2755 SHALL BE SPECIFIED ON THE COMPONENT DRAWING.</p> <p>6. EXAMPLES OF COMPONENT DRAWING HEAT TREATMENT REQUIREMENTS.</p>	<p>A. EXAMPLE FOR CLASS A HEAT TREATMENT (1) SPEC MIL-H-6875, HARDEN AND TEMPER TO HARDNESS RH C40 TO 45 (2) DWG B44XXXZ, CLASS A NITRIDE (3) NITRIDING TEMPERATURE: 875F ± 25F. (4) TOTAL CASE DEPTH: .003 TO .005 (5) SURFACE HARDNESS: RH 15N 90 MIN.</p> <p>B. EXAMPLE FOR CLASS B (1) AGE TO HARDNESS RH C40 TO 45. SPEC MIL-H-6875 APPLIES. (2) DWG B44XXXZ CLASS B NITRIDE FOR CORROSION RESISTANT STEELS.</p> <p>7. NOTES A. CLASS A NITRIDE IS COMMONLY KNOWN AS AMETEK AMETRIDE PROCESS. B. CLASS B NITRIDE IS COMMONLY KNOWN AS TUFTRIDE PROCESS.</p>																																												
<table border="1" style="width: 100%; border-collapse: collapse;"> <thead> <tr> <th>MECHANICAL PROPERTIES</th> <th>PINQ SA</th> <th>UNLESS OTHERWISE SPECIFIED DIMENSIONS AND IN NOTES</th> <th>CONTRACT NUMBER</th> <th>DESIGN ACTIVITY</th> </tr> </thead> <tbody> <tr> <td>TP</td> <td></td> <td>TOLERANCES ON 1 PLACES 2 PLACES A B</td> <td>CONTRACTOR</td> <td></td> </tr> <tr> <td>TS</td> <td></td> <td></td> <td>DRAWN BY (DATE/NO 94)</td> <td></td> </tr> <tr> <td>TE</td> <td></td> <td></td> <td>CHECKER NUMBER</td> <td></td> </tr> <tr> <td>ED</td> <td></td> <td></td> <td>DRAWING APPROVAL</td> <td>DATE DATE CODE</td> </tr> <tr> <td>SH</td> <td></td> <td></td> <td>DESIGN APPROVAL</td> <td>SCALE UNIT WT SHEET</td> </tr> <tr> <td>SP</td> <td></td> <td></td> <td></td> <td></td> </tr> <tr> <td></td> <td>REST AREA</td> <td>USED ON</td> <td></td> <td></td> </tr> <tr> <td></td> <td colspan="2">APPLICATION</td> <td></td> <td></td> </tr> </tbody> </table>	MECHANICAL PROPERTIES	PINQ SA	UNLESS OTHERWISE SPECIFIED DIMENSIONS AND IN NOTES	CONTRACT NUMBER	DESIGN ACTIVITY	TP		TOLERANCES ON 1 PLACES 2 PLACES A B	CONTRACTOR		TS			DRAWN BY (DATE/NO 94)		TE			CHECKER NUMBER		ED			DRAWING APPROVAL	DATE DATE CODE	SH			DESIGN APPROVAL	SCALE UNIT WT SHEET	SP						REST AREA	USED ON				APPLICATION				
MECHANICAL PROPERTIES	PINQ SA	UNLESS OTHERWISE SPECIFIED DIMENSIONS AND IN NOTES	CONTRACT NUMBER	DESIGN ACTIVITY																																										
TP		TOLERANCES ON 1 PLACES 2 PLACES A B	CONTRACTOR																																											
TS			DRAWN BY (DATE/NO 94)																																											
TE			CHECKER NUMBER																																											
ED			DRAWING APPROVAL	DATE DATE CODE																																										
SH			DESIGN APPROVAL	SCALE UNIT WT SHEET																																										
SP																																														
	REST AREA	USED ON																																												
	APPLICATION																																													

FIGURE D-18. General requirements drawing

This sample drawing is informational only and complete to the degree necessary to illustrate a type of drawing. Actual format and drawing shall conform to the textual requirements set forth in this standard.

DOD-STD-00100D(AR)

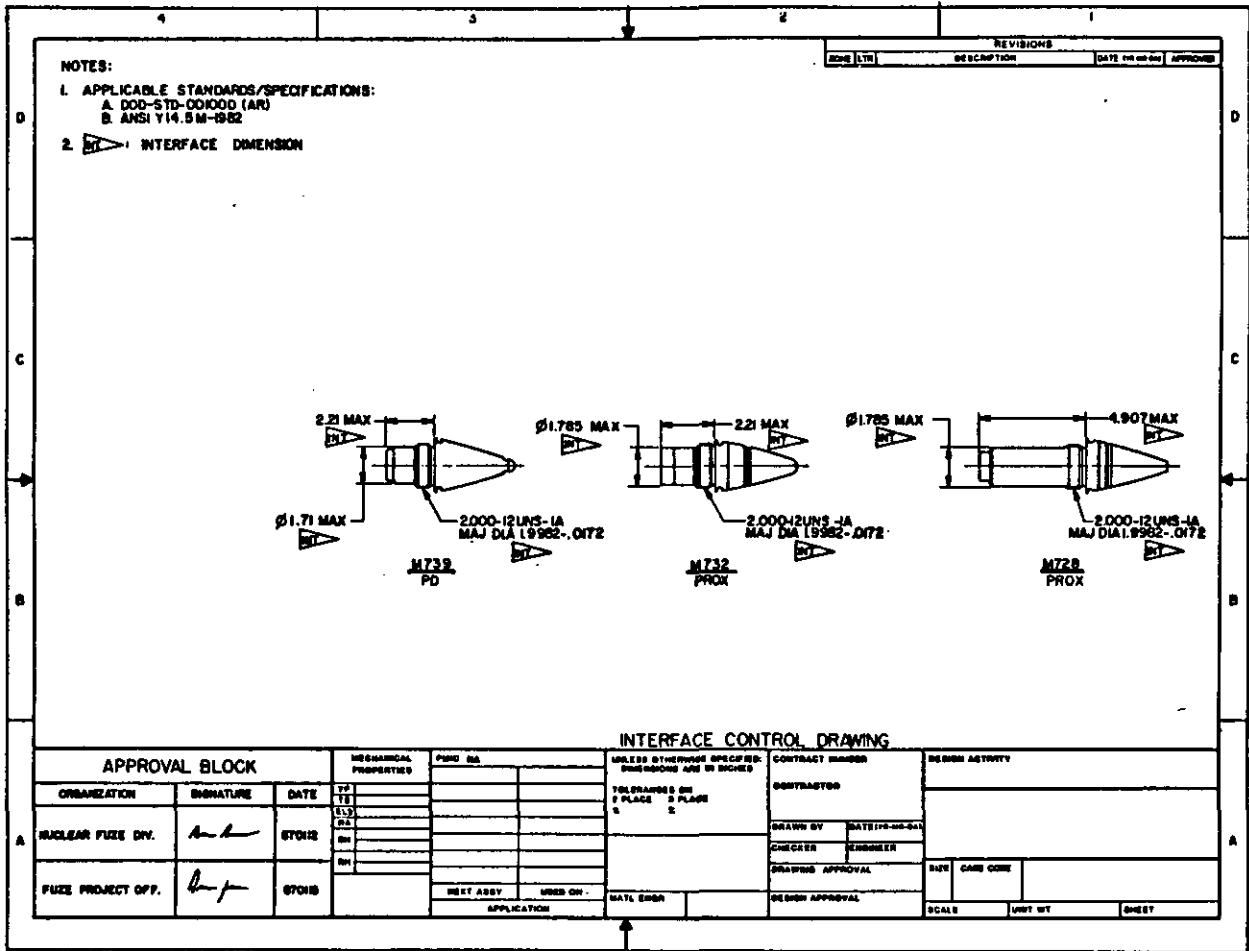

FIGURE D-19. Interface control drawing

This sample drawing is informational only and complete to the degree necessary to illustrate a type of drawing. Actual format and drawing shall conform to the textual requirements set forth in this standard.

DOD-STD-00100D(AR)

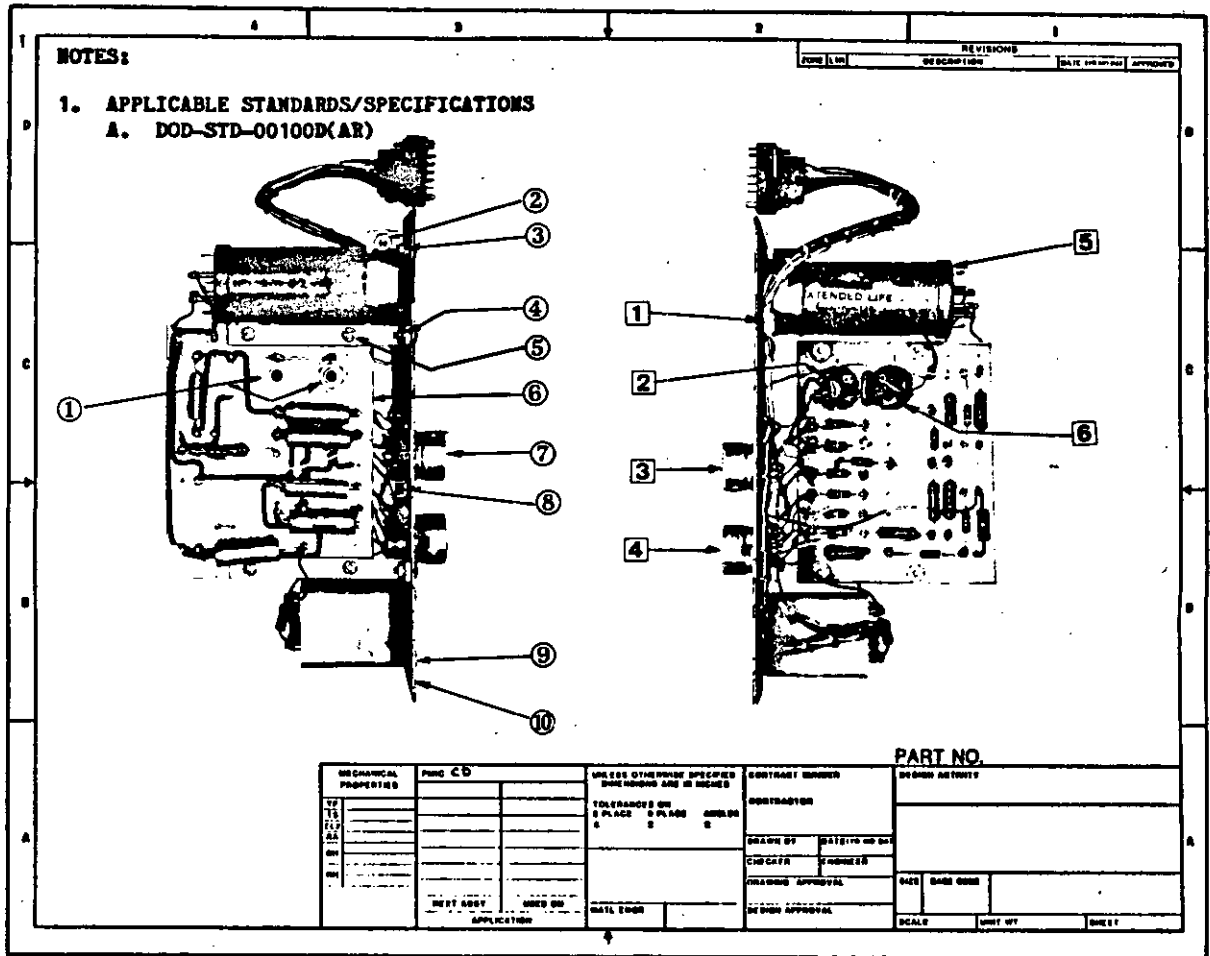

FIGURE D-20. Photo assembly drawing

This sample drawing is informational only and complete to the degree necessary to illustrate a type of drawing. Actual format and drawing shall conform to the textual requirements set forth in this standard.

DOD-STD-00100D(AR)

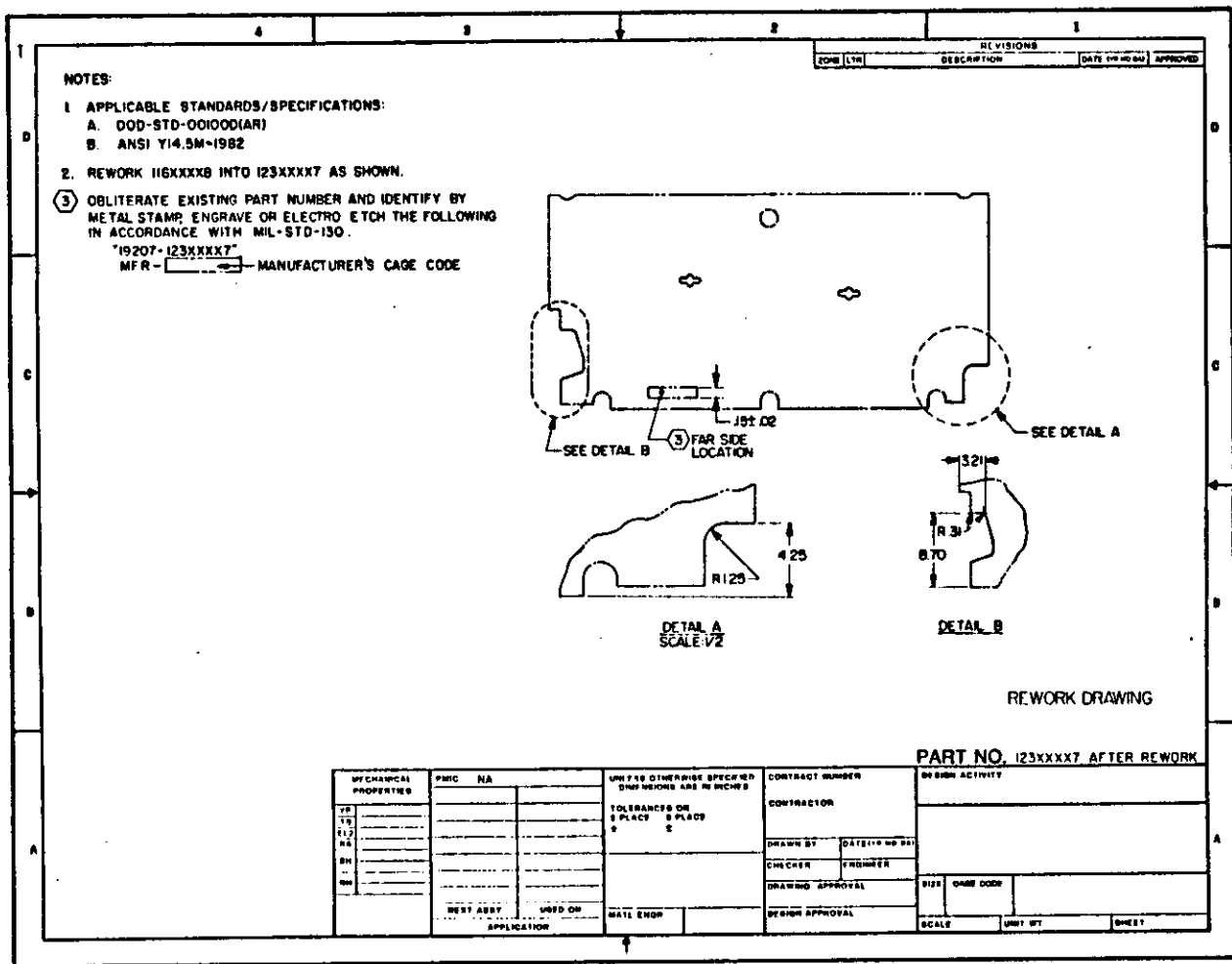

FIGURE D-21. Rework drawing

This sample drawing is informational only and complete to the degree necessary to illustrate a type of drawing. Actual format and drawing shall conform to the textual requirements set forth in this standard.

DOD-STD-00100D(AR)

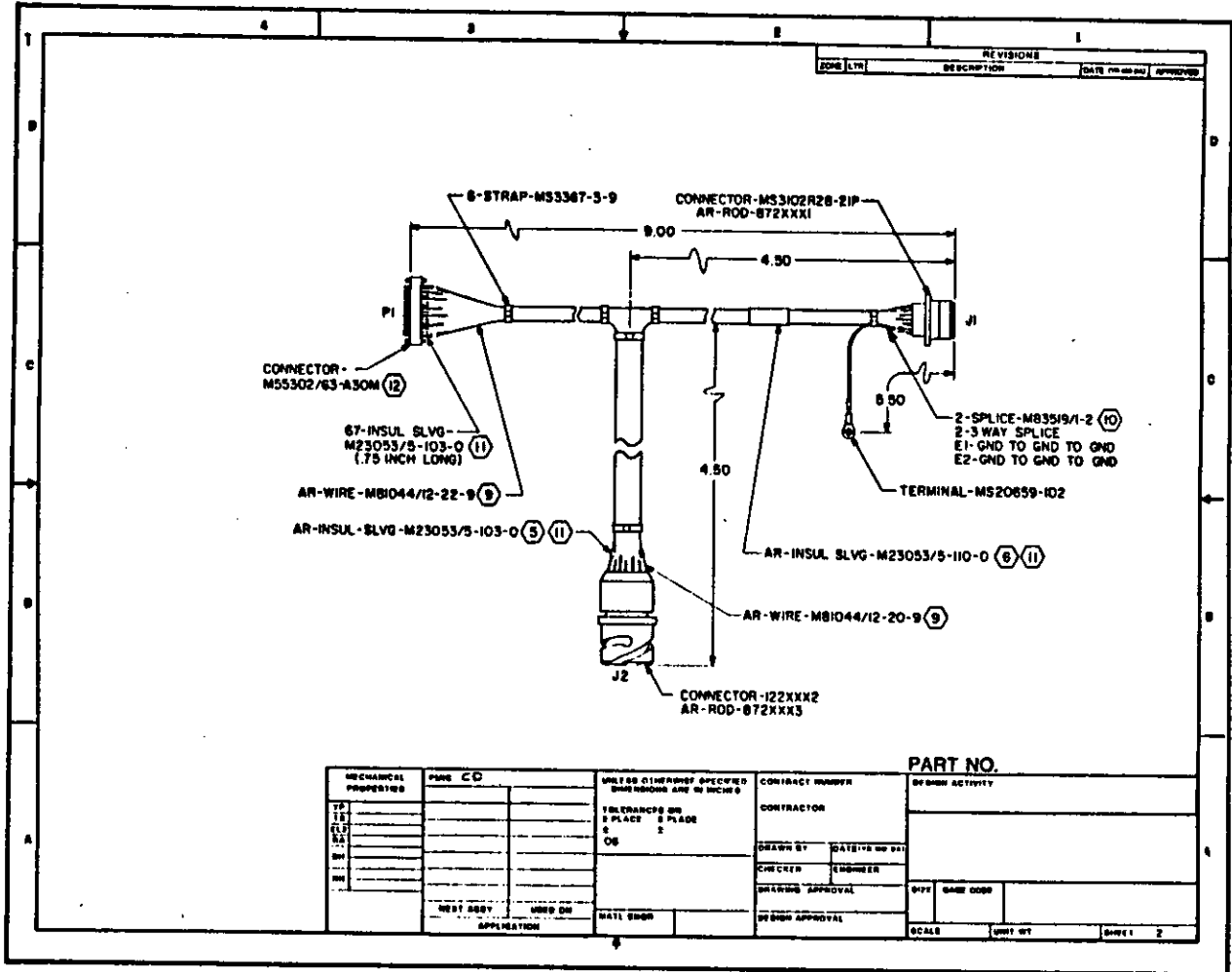

FIGURE D-22. Cable assembly drawing

This sample drawing is informational only and complete to the degree necessary to illustrate a type of drawing. Actual format and drawing shall conform to the textual requirements set forth in this standard.

DOD-STD-00100D(AR)

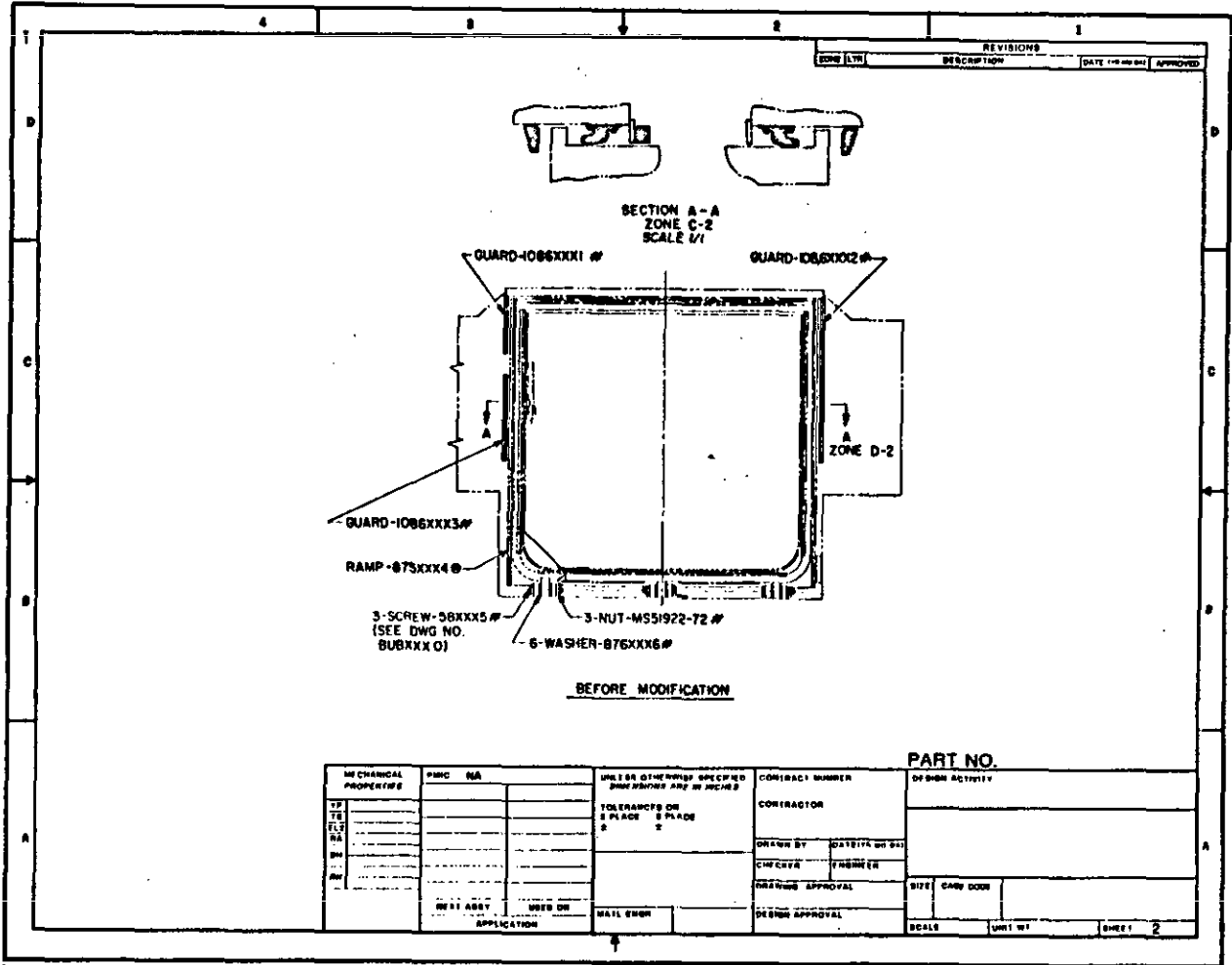

FIGURE D-23. Modification drawing (before)

This sample drawing is informational only and complete to the degree necessary to illustrate a type of drawing. Actual format and drawing shall conform to the textual requirements set forth in this standard.

DOD-STD-00100D(AR)

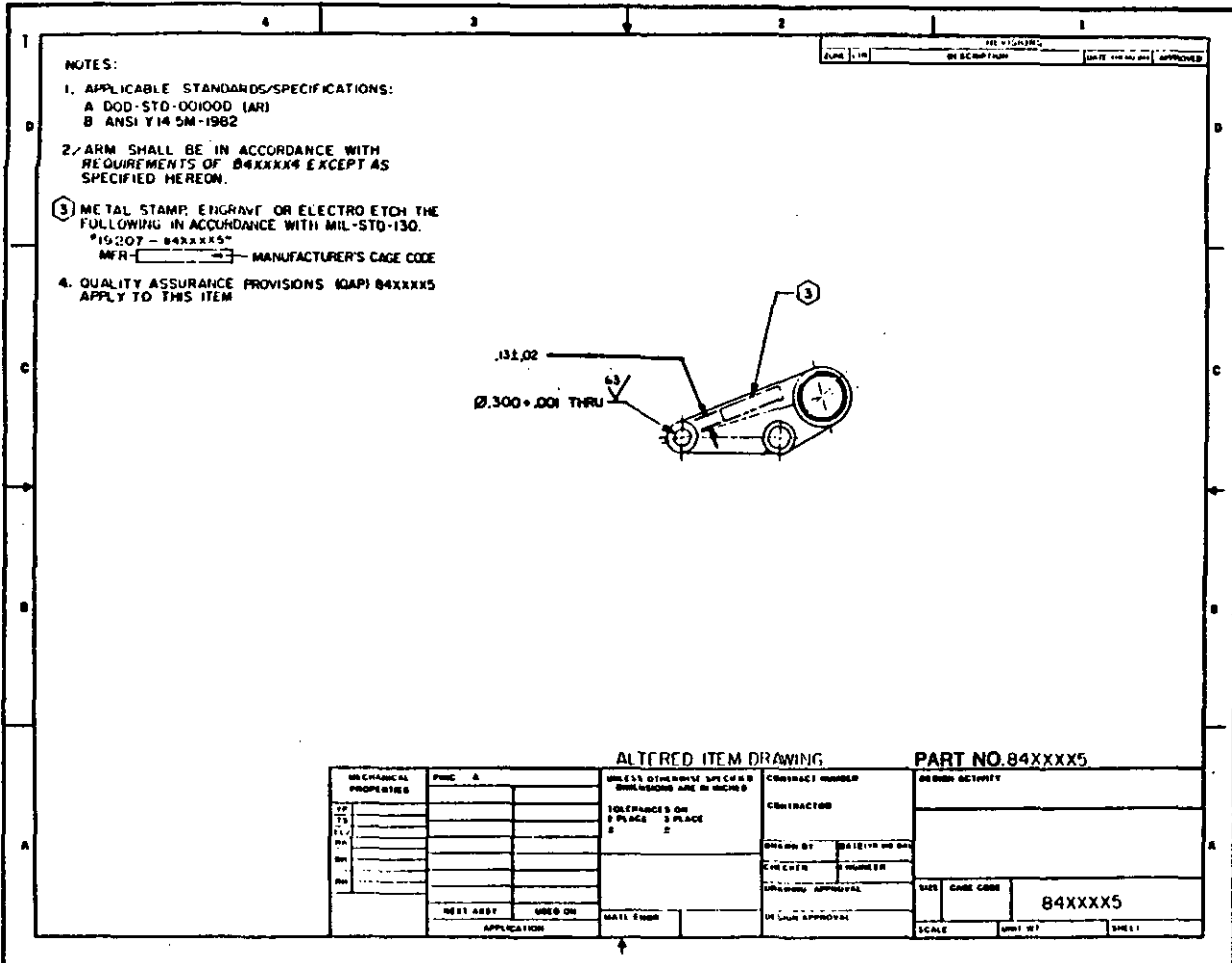

FIGURE D-25. Altered item drawing

This sample drawing is informational only and complete to the degree necessary to illustrate a type of drawing. Actual format and drawing shall conform to the textual requirements set forth in this standard.

DOD-STD-00100D(AR)

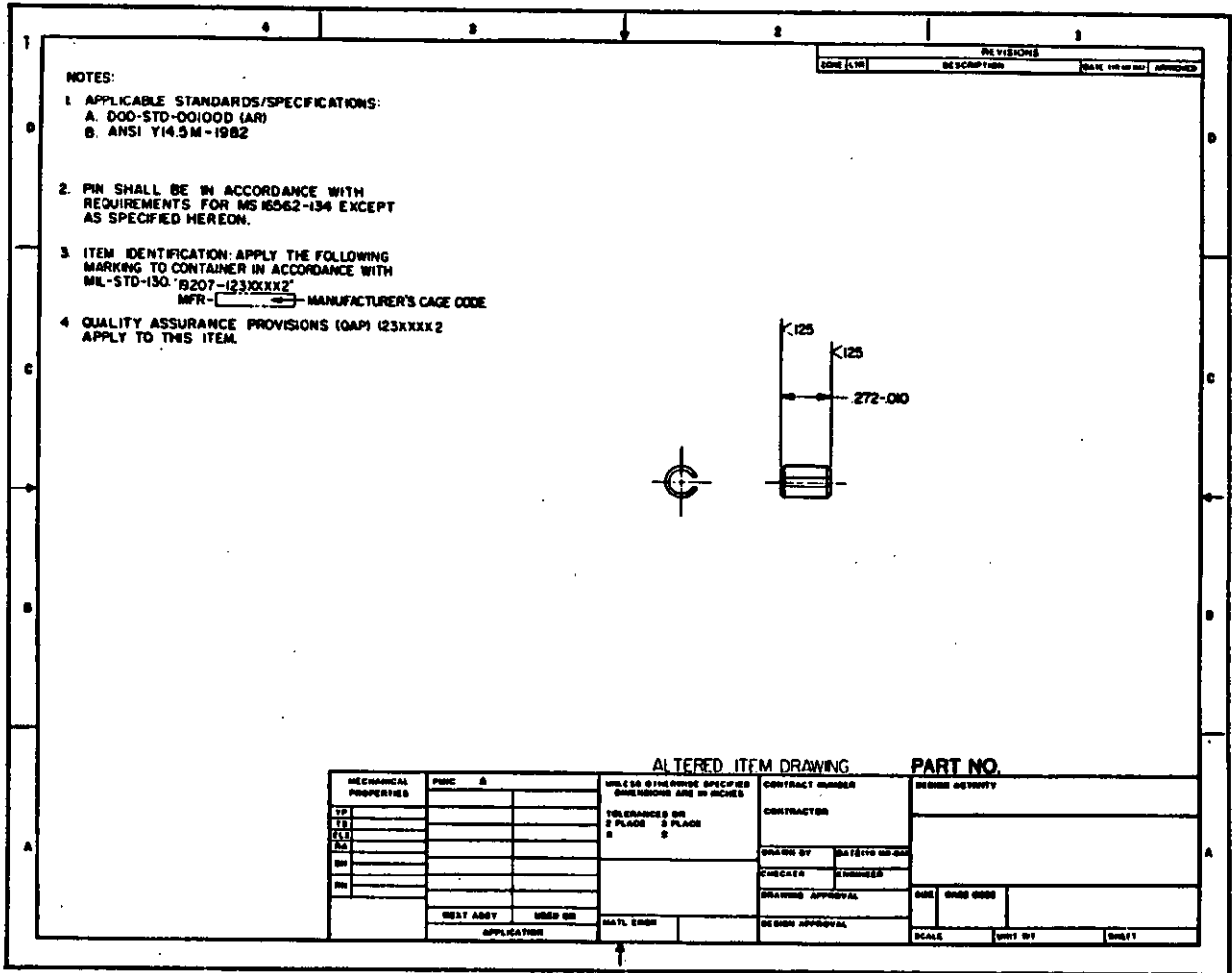

FIGURE D-26. Altered item drawing

This sample drawing is informational only and complete to the degree necessary to illustrate a type of drawing. Actual format and drawing shall conform to the textual requirements set forth in this standard.

DOD-STD-00100D(AR)

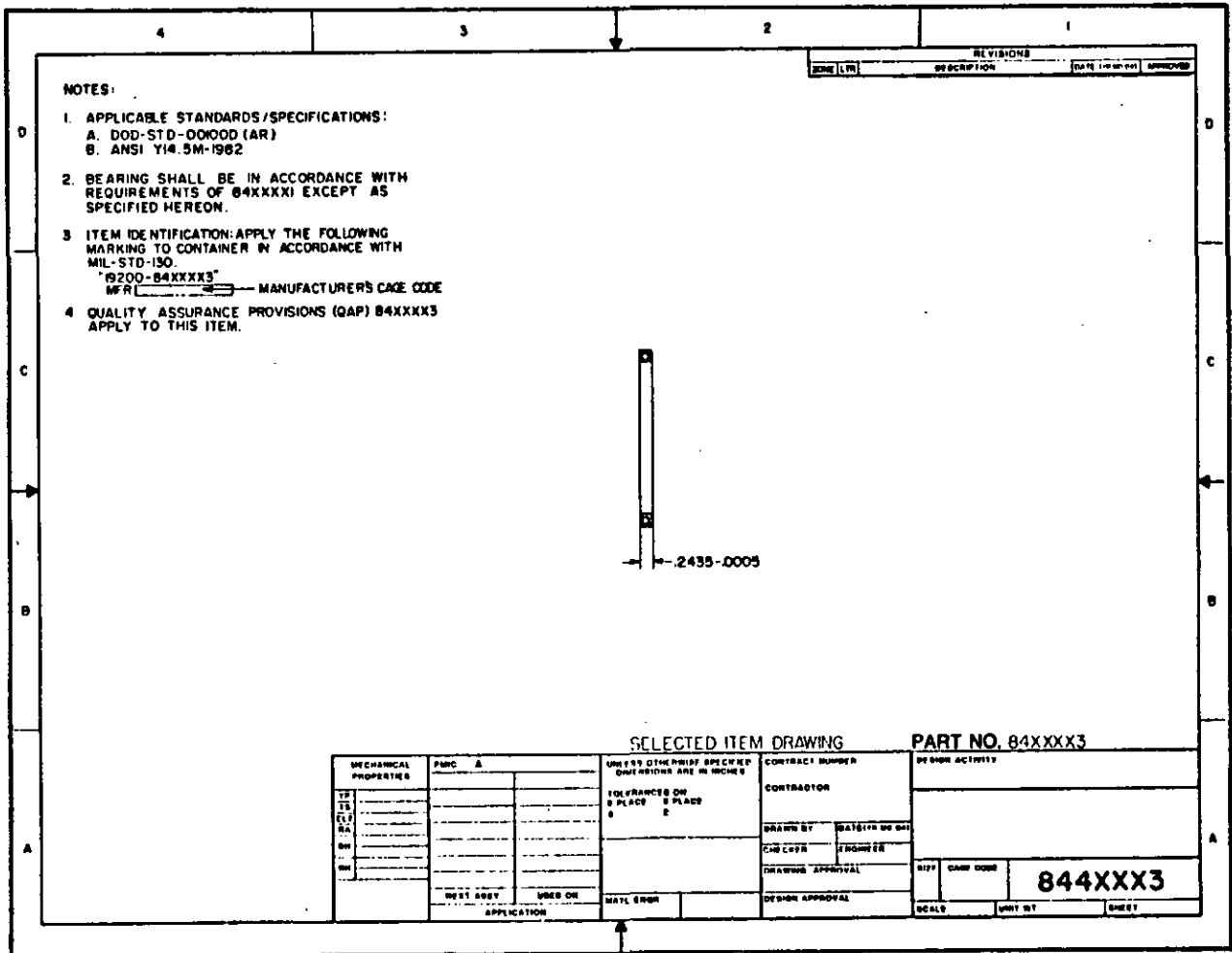

FIGURE D-27. Selected item drawing

This sample drawing is informational only and complete to the degree necessary to illustrate a type of drawing. Actual format and drawing shall conform to the textual requirements set forth in this standard.

DOD-STD-00100D(AR)

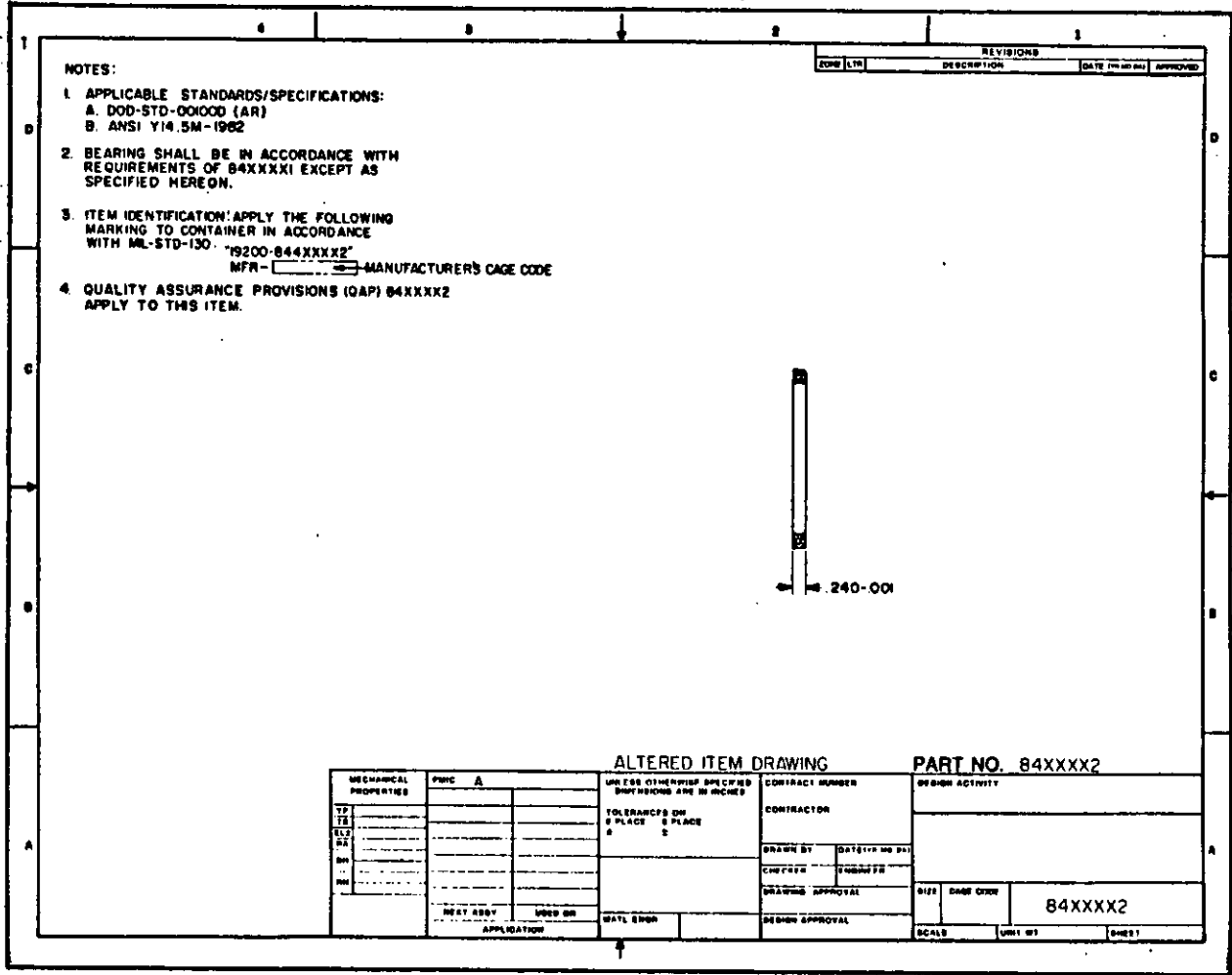

FIGURE D-28. Altered item drawing/part controlled by Source Control Drawing

This sample drawing is informational only and complete to the degree necessary to illustrate a type of drawing. Actual format and drawing shall conform to the textual requirements set forth in this standard.

DOD-STD-00100D (AR)

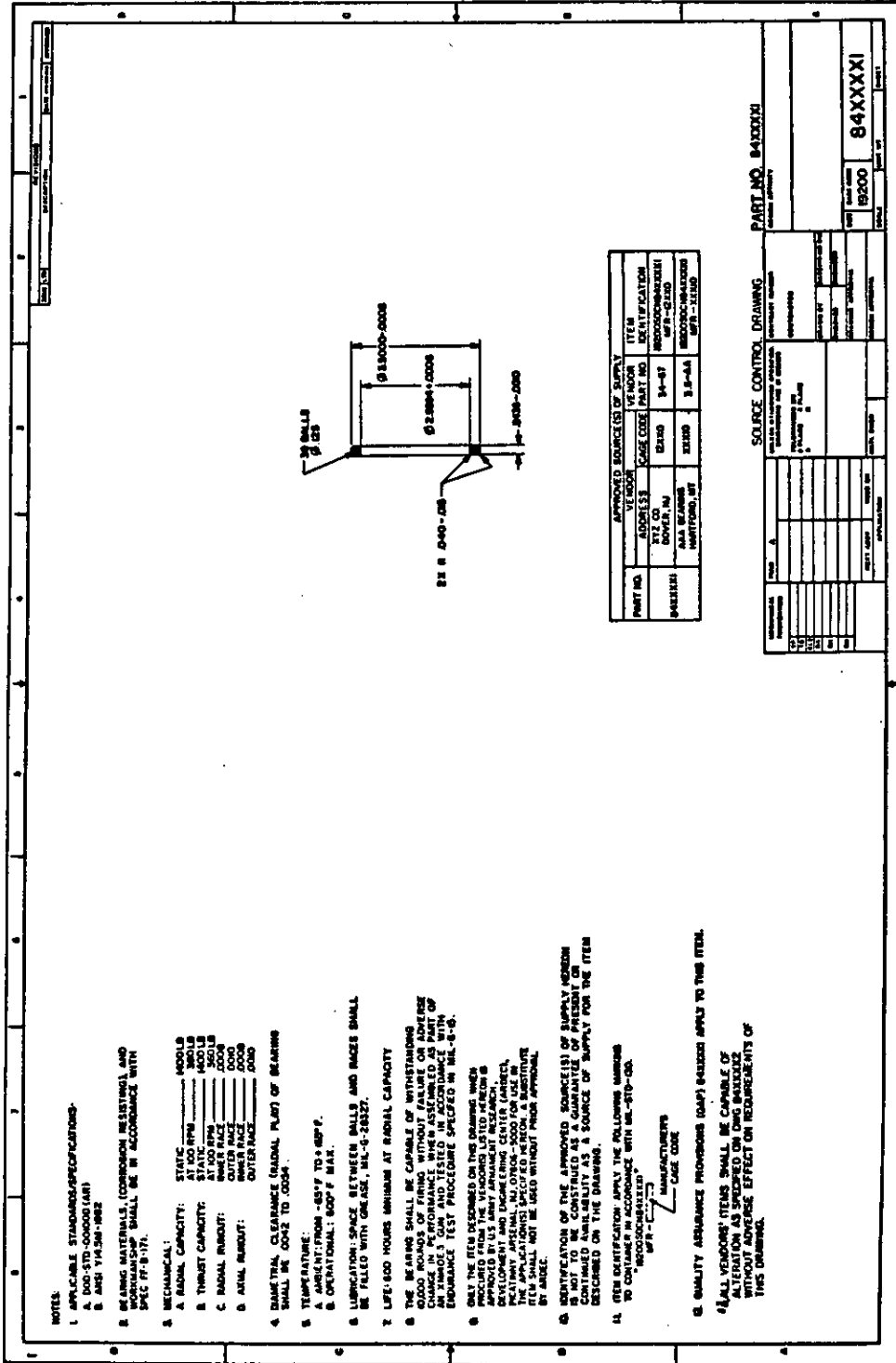

FIGURE D-29. Source control drawing

This sample drawing is informational only and complete to the degree necessary to illustrate a type of drawing. Actual format and drawing shall conform to the textual requirements set forth in this standard.

DOD-STD-00100D(AR)

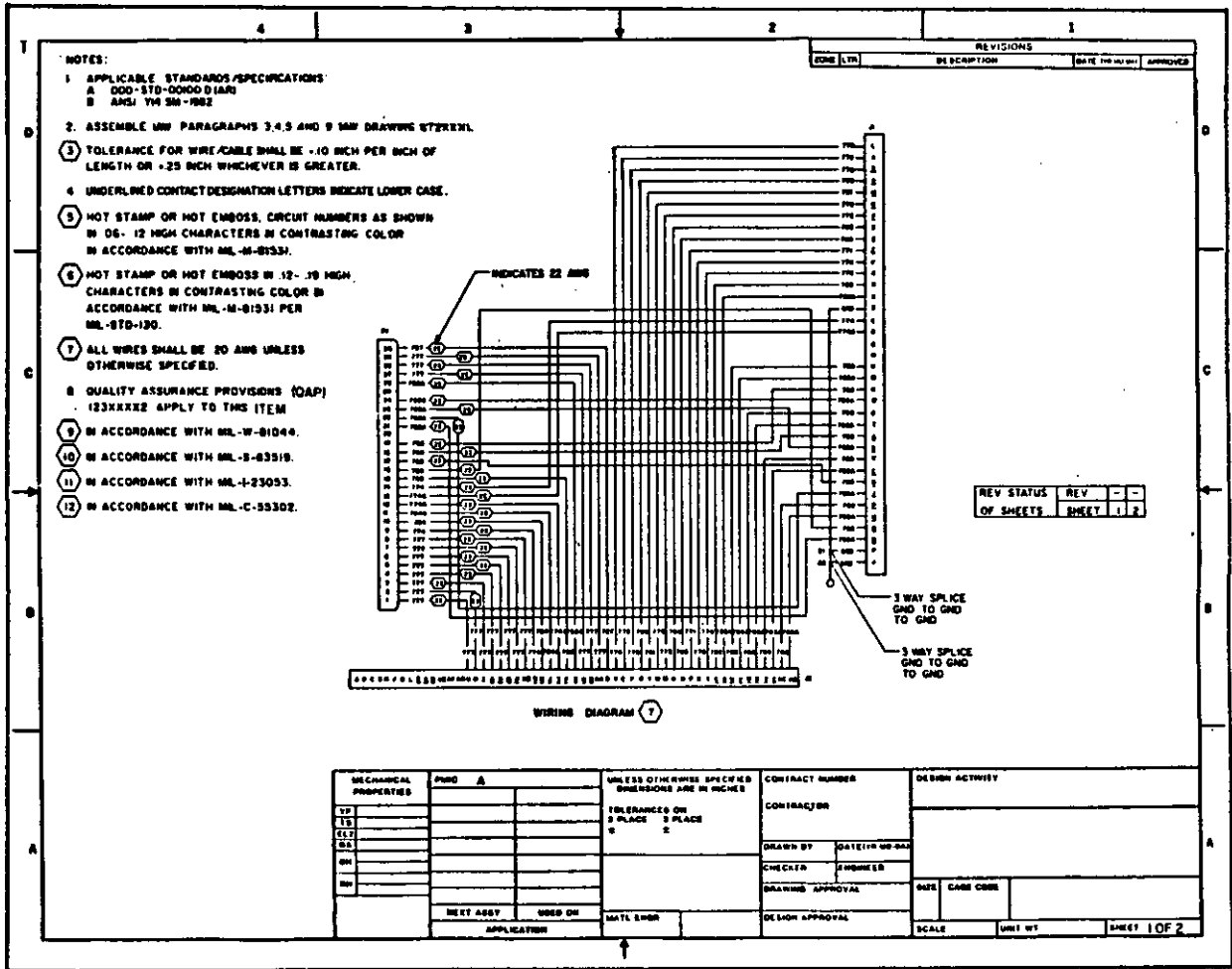

FIGURE D-30. Wiring diagram

This sample drawing is informational only and complete to the degree necessary to illustrate a type of drawing. Actual format and drawing shall conform to the textual requirements set forth in this standard.

DOD-STD-00100D(AR)

APPENDIX E
REVISION OF DRAWINGS

283

DOD-STD-00100D(AR)

APPENDIX E

REVISION OF DRAWINGS

1. This appendix defines the requirements for identifying the location of and recording revisions on drawings. Optional methods are described; however, use of any method shall be only as directed by the Government Design Activity responsible for the data bases of the commodities involved.
2. The methods define the requirements for recording revisions:
 - a. Prior to establishment of the Allocated Baseline
 - b. Prior to implementation of Formal Engineering Change Control, either by Contractor or Government.
 - c. After a or b or both above but prior to establishment of the Product Baseline.
 - d. After establishment of the Product Baseline.
 - e. After acquisition of data in as-is condition from other sources.
3. General Rules.
 - a. Only drawings that are associated with an Allocated Configuration Identification shall be identified and Allocated Baseline released.
 - b. Formal Engineering Change control usually applies for data representing the approved DT/OT II configuration.
 - c. All drawings shall be identified with Product Baseline release. (formally identified as Production or Initial release.)
 - d. The only form authorized for use as a "revision authorization document" is DD 1695, Notice of Revision (NOR).
 - e. Revision letters subsequent to Product Baseline release shall be in accordance with paragraph 503.2.

DOD-STD-00100D(AR)

APPENDIX E (Cont'd)

4. Method A. (FIGURE E-1)

a. This method utilizes the "X" revision letter system for recording revisions. "X₀ (ZERO)" is the first entry applied when the drawing is prepared. "XA", "XB", etc., are used for revisions up to PRODUCT BASELINE release. At Product Baseline, the revision symbol shall be a dash "-". Subsequent to Product Baseline, the first revision shall be "A", the next "B", etc.

b. The method of recording changes shall be:

(1) For changes prior to Formal Engineering Change Control:

A. Enter next sequential Revision letter starting with "XA".

B. Enter a brief description of the change(s) in the description block. Include Zone location, if applicable, in appropriate column.

C. Approval date and signature shall also be entered.

(2) For changes starting with and subsequent to Formal Engineering Change Control and prior to Product Baseline:

A. Enter next sequential "X_" Revision letter.

B. Enter NOR number and NOR approval date.

C. Revision approval date and signature shall also be entered.

NOTE: Zone indication shall not be made.

(3) For Product Baseline release:

A. Enter dash "-" revision symbol.

B. Enter Engineering Release Record (ERR) number.

C. The revision approval date shall be the date on which the drawing is annotated for Product Baseline.

D. Enter approval signature.

DOD-STD-00100D(AR)

APPENDIX E (Cont'd)

REVISIONS					
ZONE	LTR	DESCRIPTION	DATE (YR-MO-DA)	APPROVED	
	XØ	(ZERO)			
C5	XA	DIM. .07 +.06 ADDED	77-06-01	—	
	XB	NOR W7T3026	77-09-16	77-10-25	—
	XC	NOR W7T2037	77-11-22	77-12-03	—
		PRODUCT BASELINE ERR W7T2122		78-02-14	—
	A	NOR A8A2594	78-10-20	78-11-02	—
	B	NOR A9A2404	79-01-03	79-02-12	—

FIGURE E-1. Example of Recording Revisions in Accordance with METHOD A

DOD-STD-00100D(AR)

APPENDIX E (Cont'd)

5. METHOD B. (FIGURE E-2)

a. This method is the same as METHOD A except when the drawing is used for the ALLOCATED BASELINE, it shall be annotated. The next sequential "X_" Revision letter shall be used for this release.

REVISIONS				
ZONE	LTR	DESCRIPTION	DATE (YR-MO-DA)	APPROVED
	XØ (ZERO)			
	XA	FINISH NOTE 10 ADDED	75-07-12	---
C4	XB	DIM ".06+.02" WAS ".06+.01"	77-03-01	---
	XC	ALLOCATED BASELINE ERR A7A2501	77-10-02	---
	XD	NOR A8A2500 78-03-30	78-04-01	---
	XE	NOR A8A2530 78-05-06	78-06-12	---
		PRODUCT BASELINE ERR A8A2567	78-08-06	---
	A	NOR A8A2594 78-10-23	78-11-02	---
	B	NOR A9A2404 79-01-03	79-02-12	---

FIGURE E-2. Example of Recording Revisions in accordance with METHOD B

DOD-STD-00100D(AR)

APPENDIX E (Cont'd)

6. METHOD C. (FIGURE E-3)

a. This method utilizes Revision letter "A" for the first drawing change, then "B", "C", etc., for subsequent actions. For Product Baseline, the Revision symbol shall be a dash "-". Revision letters for subsequent changes shall be the next sequential letter.

b. The method of recording the description of change shall be the same as for METHOD A.

c. When existing drawings are acquired on which revisions were identified by this method, i.e., "A" for first revision, then "B" etc., subsequent changes shall be identified as follows:

(1) Changes prior to Product Baseline shall continue to be identified sequentially.

(2) Product Baseline release shall be identified by the next sequential Revision letter.

(3) Subsequent changes shall be identified by the next sequential Revision letter.

REVISIONS				
ZONE	LTR	DESCRIPTION	DATE (YR-MO-DA)	APPROVED
D8	A	ADDED QAR NOTE	84-02-10	—
B7	B	INC ADCN 103645 1) ADDED 6		
C4		INC ADCN 18865 2) 2A WAS 3		
A6		3) "2A" WAS "3" IN DIAGRAM	84-03-01	—
	C	ADDED PARA 9 IN NOTE 2	84-04-23	—
	D	PRODUCT BASELINE ERR FOM K2650	84-09-02	—
D8	E	1) ADDED NOTE 10		
C6		2) DIM 1.25 WAS 1.30 FOM K3025	84-10-12	—

FIGURE E-3. Example of Recording Revisions in Accordance with METHOD C

DOD-STD-00100D(AR)

APPENDIX E (Cont'd)

7. METHOD D. (FIGURE E-4)

a. This method requires drawings that are released for Product Baseline and show no record of previous revision actions. The Product Baseline release shall be the first entry in the revision block. Subsequent changes shall be identified with Revision letter starting with "A", then "B", etc.

b. Normally, this method is used for in-house actions, and when no formal records are maintained in any database (Government or Contractor) for previous changes.

REVISIONS					
ZONE	LTR	DESCRIPTION		DATE (YR-MO-DA)	APPROVED
	—	PRODUCT BASELINE ERR WOS2345		80-06-12	—
	A	NOR W2S2569	73-07-23	73-12-22	—
	B	NOR W4S2922	84-03-15	84-10-13	—

FIGURE E-4. Example of Recording Revisions in accordance with METHOD D

DOD-STD-00100D(AR)

APPENDIX E (Cont'd)

8. METHOD E. (FIGURES E-5a and E-5b)

a. This method provides for adaptation of existing data where revisions are identified numerically rather than alphabetically.

b. Subsequent revisions shall be identified as follows:

(1) For changes prior to Formal Engineering Change Control:

A. Enter next sequential Revision number.

B. Enter a brief description of the change(s) in the description block. Include Zone location, if applicable, in appropriate column.

C. Approval date and signature shall also be entered.

(2) After delivery of data, prior to recording in database and prior to Formal Change Control, drawings shall be identified with "X~~0~~ (ZERO)" Revision letter and approval date and signature. This procedure shall apply only if not establishing the Product Baseline. If establishing Product Baseline, enter dash "-", Revision symbol, etc., in accordance with Para b(4) below. See FIGURE E-5b.

(3) For changes starting with and subsequent to Formal Engineering Change Control (See FIGURE E-5a):

A. Enter sequential "X_" Revision letter, starting with "XA".

B. Enter NOR number and NOR approval date.

C. Revision approval date and signature shall also be entered.

NOTE: Zone indication shall not be made.

(4) For Product Baseline release:

A. Enter dash "-" revision symbol.

B. Enter Engineering Release Record (ERR) number.

C. The revision approval date shall be the date on which the drawing is annotated for Product Baseline.

D. Enter approval signature.

DOD-STD-00100D(AR)

APPENDIX E (Cont'd)

REVISIONS				
ZONE	LTR	DESCRIPTION	DATE (YR-MO-DA)	APPROVED
B7	1	ADDED ".06 +.02", ".17 +.01"	12 JUN 80	—
	2	NOTE 2 REMOVED	SEP 6, 81	—
	3	HEAT TREATMENT REVISED	01/12 /82	—
	X(ZERO)	—————	82-05-22	—
	XA	NOR W8T2106 82-06-30	82-07-25	—
	XB	NOR W8T3225 82-09-07	82-10-10	—
	—	PRODUCT BASELINE ERR W8T2222	82-11-16	—
	A	NOR W9T2010 83-02-11	83-03-11	—
	B	NOR W9T3007 83-05-09	83-07-09	—

FIGURE E-5a. Example of Recording Revisions for Formal Engineering Change Control in accordance with METHOD E

REVISIONS				
ZONE	LTR	DESCRIPTION	DATE (YR-MO-DA)	APPROVED
B7	1	ADDED ".06 +.02", ".17 +.01"	12 JUN 80	—
	2	NOTE 2 REMOVED	SEP 6, 81	—
	3	HEAT TREATMENT REVISED	01/12 /82	—
	—	PRODUCT BASELINE ERR W8T2222	82-11-16	—
	A	NOR W9T2010 83-02-11	83-03-11	—
	B	NOR W9T3007 83-05-09	83-07-09	—

FIGURE E-5b. Example of Recording Product Baseline and Revisions in accordance with METHOD E

DOD-STD-00100D(AR)

APPENDIX E (Cont'd)**9. METHOD F. (FIGURE E-6)**

a. This method may be used as an alternative to METHODS A, B, and C for Product Baseline release.

b. The last revision symbol and date prior to Product Baseline is carried over and shown in the revision block for continuity.

c. This method is used when formal records are maintained (Government or Contractor) for previous changes.

Last Revision Symbol Prior to Product Baseline

REVISIONS				
ZONE	LTR	DESCRIPTION	DATE (YR-MO-DA)	APPROVED
			78-06-12	—
	—	PRODUCT BASELINE ERR A8A2567	78-09-14	—

FIGURE E-6. Example of Recording Revisions in accordance with METHOD F

DOD-STD-00100D(AR)

10. Manually prepared multi-sheet parts lists are not required to be maintained at the same revision level.

PARTS LIST			DESIGN ACTIVITY				CAGE CODE CEREBIT CALZORAL		ORIG. DATE (YY-MM-DD)		PL		
LIST TITLE						AUTHENTICATION				SHEET OF SHEETS			
										DWG. NO.			
10 PDR NO.	11 QTY REQD	12 CAGE CODE	13 PART OR IDENTIFYING NO.	DRAWING/DOCUMENT		NOMENCLATURE OR DESCRIPTION					16 SUPPL LIST	17 NOTES	
				14 SIZE	15 NUMBER								
18 LTR	DESCRIPTION	DATE (YY-MM-DD)	APPR	18 LTR	DESCRIPTION	DATE (YY-MM-DD)	APPR	18 LTR	DESCRIPTION	DATE (YY-MM-DD)	APPR		
A	NOR W8A2109	78-03-23	<u> </u>										

293

FIGURE E-7. Example of Recording Revision on manually prepared parts list

DOD-STD-00100D(AR)

THIS PAGE LEFT BLANK INTENTIONALLY

294

DOD-STD-00100D(AR)

APPENDIX F
COMMONLY USED CAGE CODES

295-

DOD-STD-00100D(AR)

APPENDIX F

COMMONLY USED CAGE CODES

<u>CAGE Code</u>	<u>PROPONENT AGENCY</u>	<u>TYPICAL DOCUMENT IDENTIFICATION PATTERNS</u>
10060	National Standards Association	NAS xxxx NAS xxxx-xxxx
21450	Army Weapons Command, Rock Island	BAOX2 DTDX1
80204	American National Standards Institute	ANSI-Bxx.xx ANSI-Bxx.xxM
81346	American Society for Testing and Materiels	ASTM-Dxxx
81348	Federal Specifications promulgated by General Services Administration	J-C-xxx HH-I-xxx GGG-P-xxxx
81349	Military Specifications promulgated by Military Departments/Agencies	MIL-A-xxx MIL-B-xxxx MIL-C-xxxxx (DOD-A-xxx)
81350	Joint Army-Navy specifications promulgated by Military Departments	JAN-P-xxx
81352	Air Force-Navy Aeronautical Specifications promulgated by the Aeronautical Standards Group	ANxC-xxx ANxxxxx ANxxx-Sxx
96906	Military Standards	MSxxxx MSxxxxx MIL-STD-xxx (DOD-STD-xxx)

DOD-STD-00100D(AR)

APPENDIX G

INITIAL/SIGNATURE REQUIREMENTS

46e

DOD-STD-00100D(AR)

APPENDIX G

INITIAL/SIGNATURE REQUIREMENTS

All documents that represent original drawings shall be initialed/signed by appropriate personnel.

Redrawn documents with same number are considered a revision; therefore, the original initials/signatures shall be shown as printed reproductions.

Initial original CAD generated drawings shall be initialed/signed in same manner as for manually prepared drawings. For subsequent generations prepared by CAD, printed reproductions of initials/signatures are acceptable.

For CAD generated microfilm, authentication initials/signatures shall be provided on the back of the aperture card. Subsequent revisions generated as microfilms, printed reproductions of initials/signatures are acceptable. See FIGURE G-1 for matrix of initial/signature requirements for various versions of drawings. The same requirements apply for associated lists.

	DESIGNER		CHECKER		ENGINEER		DESIGN APPROVAL		DESIGN APPROVAL		PROC. ENGINEER		OTHER APPROVALS		MULTIPLE APPROVALS		REFERENCE PAGE	NOTES
	INITIALS		INITIALS		SIGNATURE		SIGNATURE		SIGNATURE		INITIALS		INITIALS		SIGNATURE			
	ORIGINAL SCRIPT	PRINTED	ORIGINAL SCRIPT	PRINTED	ORIGINAL	PRINTED	ORIGINAL	PRINTED	ORIGINAL	PRINTED	ORIGINAL SCRIPT	PRINTED	ORIGINAL SCRIPT	PRINTED	ORIGINAL	PRINTED		
ORIGINAL DRAWINGS	X		X		X		X		X		X		X				119	
REVISIONS																X	504	
REDRAWN WITH SAME NO. • SUPERSEDING (NEW) DRAWING		X		X		X		X		X		X		X	X		119, 504	1
REPLACING WITH DIFFERENT NO. • SUPERSEDING (NEW) DRAWING • SUPERSEDING (OLD) DRAWING	X		X		X		X		X		X		X			X	119 504	
CAD PREPARED DRAWINGS • INITIAL ORIGINAL DRAWING • CONVENTIONAL REVISIONS	X		X		X		X		X		X		X			X	119 504	1
• SUBSEQUENT (CAD) REVISIONS		X		X		X		X		X		X		X	X		504	
CAD GENERATED MICROFILM																		
• APERTURE CARD (BACK) INITIAL VERSION • SUBSEQUENT CAD REVISION	X		X		X		X		X		X		X				119	1
• SUBSEQUENT VERSIONS OF MICROFILM IMAGE		X		X		X		X		X		X		X	X		504	

NOTES:
1. If legible, all signatures and initials on the original drawing shall be reproduced on redrawn/retraced drawings by printed letters. If not legible or missing, the drawing shall be treated as a new drawing, and the block shall be initialed/signed by current responsible personnel.

FIGURE G-1. Initial Signature Requirements

DOD-STD-00100D(AR)

APPENDIX H

**MARKING AND DISTRIBUTION STATEMENTS
FOR TECHNICAL DOCUMENTS**

652
299

DOD-STD-00100D(AR)

H1 Distribution Statements and Additional Notices. Statements and Notices shall be in accordance with DoD 5010.12-M, Chapter 5 and the following:

H1.1 Assigning Statements and Notices. Assignment of Distribution Statements and Notices to engineering drawings and associated lists denote the extent to which they are available for distribution, release, and dissemination without additional approvals or authorization. Marking of associated lists shall be based on the content of the list and not the classification of the drawing.

H2 Distribution Statements. The following distribution statements are authorized for use on engineering drawings and associated lists.

a. DISTRIBUTION STATEMENT A. APPROVED FOR PUBLIC RELEASE; DISTRIBUTION IS UNLIMITED.

b. DISTRIBUTION STATEMENT B. DISTRIBUTION AUTHORIZED TO U.S. GOVERNMENT AGENCIES ONLY (*fill in reason*) (*date of determination; YR-MO-DA*). OTHER REQUESTS FOR THIS DOCUMENT SHALL BE REFERRED TO (*insert controlling DoV office*).

c. DISTRIBUTION STATEMENT C. DISTRIBUTION AUTHORIZED TO U.S. GOVERNMENT AGENCIES AND THEIR CONTRACTORS (*fill in reason*) (*date of determination; YR-MO-DA*). OTHER REQUESTS FOR THIS DOCUMENT SHALL BE REFERRED TO *insert controlling DoV office*).

d. DISTRIBUTION STATEMENT D. DISTRIBUTION AUTHORIZED TO THE DEPARTMENT OF DEFENSE AND DoD CONTRACTORS ONLY (*fill in reason*) (*date of determination; YR-MO-DA*). OTHER REQUESTS SHALL BE REFERRED TO (*insert controlling DoV office*).

e. DISTRIBUTION STATEMENT E. DISTRIBUTION AUTHORIZED TO DoD COMPONENTS ONLY (*fill in reason*) (*date of determination; YR-MO-DA*). OTHER REQUESTS SHALL BE REFERRED TO (*insert controlling DoD office*).

f. DISTRIBUTION STATEMENT F. FURTHER DISSEMINATION ONLY AS DIRECTED BY (*insert controlling DoD office*) (*date of determination; YR-MO-DA*) OR HIGHER DoD AUTHORITY.

g. DISTRIBUTION STATEMENT X. DISTRIBUTION AUTHORIZED TO U.S. GOVERNMENT AGENCIES AND PRIVATE INDIVIDUALS OR ENTERPRISES ELIGIBLE TO OBTAIN EXPORT-CONTROLLED TECHNICAL DATA IN ACCORDANCE WITH REGULATIONS IMPLEMENTING 10 U.S.C. 140c (*date of determination; YR-MO-DA*). OTHER REQUESTS MUST BE REFERRED TO (*insert controlling DoD office*).

H3 Additional Notices. In addition to the distribution statement, the following notices shall be used when appropriate.

a. All engineering drawings and associated lists that are determined to contain export-controlled technical data shall be marked:

WARNING - THIS DOCUMENT CONTAINS TECHNICAL DATA
WHOSE EXPORT IS RESTRICTED BY THE ARMS EXPORT
CONTROL ACT (TITLE 22, U.S.C. SEC 2751 ET SEQ.) OR
EXECUTIVE ORDER 12470. VIOLATION OF THESE EXPORT
LAWS ARE SUBJECT TO SEVERE CRIMINAL PENALTIES.

DOD-STD-00100D(AR)

APPENDIX H (Cont'd)

b. All engineering drawings and associated lists marked with distribution statements B, C, D, E, F or X shall be marked:

DESTRUCTION NOTICE - FOR CLASSIFIED DOCUMENTS, FOLLOW THE PROCEDURES IN DoD 5200.22-M, INDUSTRIAL SECURITY MANUAL, SECTION II-19 OR DoD 5200.1-R, INFORMATION SECURITY PROGRAM REGULATION, CHAPTER IX. FOR UNCLASSIFIED, LIMITED DOCUMENTS, DESTROY BY ANY METHOD THAT WILL PREVENT DISCLOSURE OF CONTENTS OR RECONSTRUCTION OF THE DOCUMENT.

H4 Application (marking) of statements and notices. Statements and notices shall be applied by decals, rubber stamp, or by lettering template. Lettering shall meet the reproduction requirements of the engineering drawing/associated lists.

H4.1 Size of lettering. Lettering shall be equal to the size largest note lettering on the drawing or associated list.

H4.2 Color of lettering. All lettering and notations shall be black.

H4.3 Location on drawings and associated lists. See illustrations, H-1 through H-6.

H5 Additional information regarding control of unclassified Technical Data is contained in DoD 5230.25-PH.

301

DOD-STD-00100D(AR)

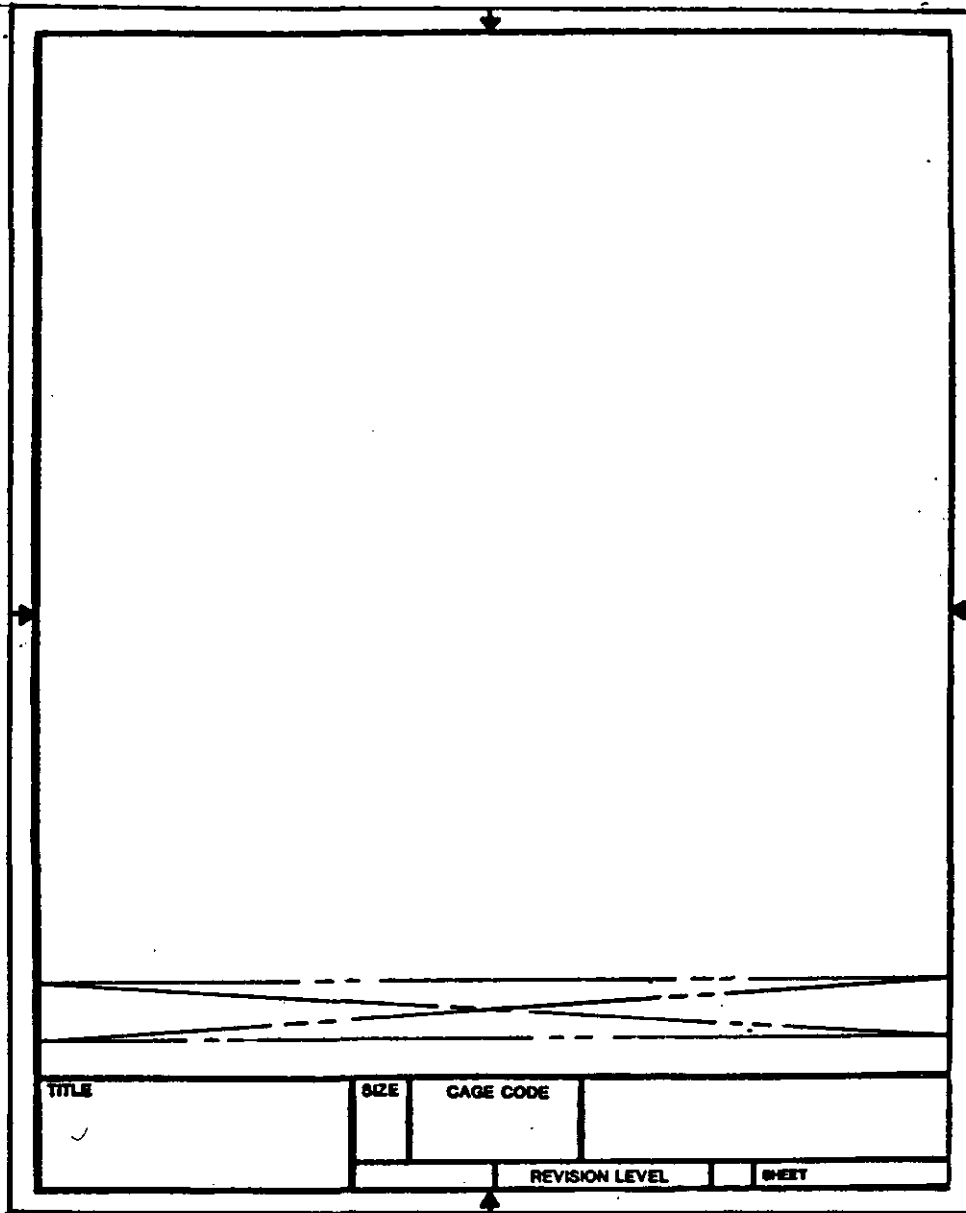

FIGURE H-2. Distribution Statement location for "A" size continuation sheet

This sample drawing is informational only and complete to the degree necessary to illustrate a type of drawing. Actual format and drawing shall conform to the textual requirements set forth in this standard.

DOD-STD-00100D(AR)

MECHANICAL PROPERTIES		PART NO.	REVISIONS	
			NO.	DESCRIPTION
YF		UNLESS OTHERWISE SPECIFIED: DIMENSIONS ARE IN INCHES TOLERANCES ON 2 PLACE 3 PLACE ± ±	CONTRACT NUMBER	
TS			CONTRACTOR	
EL			DRAWN BY	DATE (YY-MM-DD)
RA			CHECKER	ENGINEER
DN			DRAWING APPROVAL	
RM			SIZE	CAGE CODE
APPLICATION		MATL ENGR	DESIGN APPROVAL	SCALE
NEXT ASSY		USED ON	UNIT WT	SHEET

FIGURE H-3. Distribution Statement location for B size format

This sample drawing is informational only and complete to the degree necessary to illustrate a type of drawing. Actual format and drawing shall conform to the textual requirements set forth in this standard.

304

DOD-STD-00100D(AR)

GENERAL PROPERTIES		MATERIAL	TOLERANCES ON 2 PLACE		CONTRACT NUMBER		PART NO.	
SP					DESIGNED BY	DATE		
TS					CHECKED BY	SCALE		
ST					ENGINEER APPROVAL	UNIT BY		
IN					DATE	SCALE		
DN					UNIT BY	DATE		
NEXT ASSY		DATE ON	DATE ON	DATE ON	DATE ON	DATE ON		
APPLICATOR								

FIGURE H-4. Distribution Statement location for C, D, E, F, H and K size format

This sample drawing is informational only and complete to the degree necessary to illustrate a type of drawing. Actual format and drawing shall conform to the textual requirements set forth in this standard.

DOD-STD-00100D(AR)

				U.S. ARMY ARMAMENT RESEARCH, DEVELOPMENT AND ENGINEERING CENTER PICATINNY ARSENAL, NEW JERSEY 07804-5000			
PARTS LIST				CURRENT CASE CODE 19200 - ORIGINAL CASE CODE 19097		REV. DATE 21 JUN 72	
DOCUMENT/PART NUMBER P 10013599						REVISION LETTER P	
BODY ASSEMBLY						SHEET 1	
CHANGE CONTROL NUMBER 0000001				AUTHENTICATION: <i>Signature</i>		DATE 30 JUN 64	
FIG NO.	REV	UNIT CODE	PART OR IDENTIFYING NO	DRAWING/DOCUMENT NO	DESCRIPTION OR DOCUMENT TITLE	CUP	LOT
1			7649178	B 7649178	PLUG		
2			7649181	B 7649181	WASHER		
1			7649182	A 7649182	WASHER		
2			7600718	C 7600718	LENS, OBJECTIVE		
2			7600722	B 7600722	LENS, OBJECTIVE		
2			7600724	B 7600724	FILTER, GLASS		
2			7600725	C 7600725	LENS, OBJECTIVE		
1			8279046	B 8279046	SHELL		
1			8574642	B 8574642	BASKET		
1			8574881	C 8574881	SCREW		
2			8579803	A 8579803	LENS, OPTICAL INSTRUMENT, OBJECTIVE		
2			8579804	A 8579804	LENS, OPTICAL INSTRUMENT, OBJECTIVE		
2			8579805	A 8579805	LENS, OPTICAL INSTRUMENT, OBJECTIVE		
1			8589800	B 8589800	DECAL		
1			8589801	A 8589801	PLUG		
1			8589920-2	C 8589920	CAP ASSEMBLY		
6			10513511	A 10513511	SETSCREW HEX SOCKET, CUP POINT		1
2			10513556	B 10513556	SPACER		
2			10513557	B 10513557	SPACER		
2			10513558	B 10513558	RETAINER		
2			10513559	B 10513559	RETAINER		
2			10513560	B 10513560	RETAINER		
1			10513561	A 10513561	GASKET		
1			10513562	B 10513562	PLATE		
2			10513564	C 10513564	CELL		
1			10513565	C 10513565	HOUSING, OBJECTIVE		
2			10513566	B 10513566	CELL, CEMENTED		2
1			10513568	B 10513568	RING		
1			10513570	D 10513570	PRISM, BONDED		1
6			10513572	B 10513572	SPRING, COMPRESSION		
6			10513573	B 10513573	SPRING, COMPRESSION		
2			10513574	B 10513574	CONTACT		
2			10513576	C 10513576	SHIELD		
2			10513580	C 10513580	CELL ASSEMBLY		2
2			10513581	C 10513581	ADAPTER, CEMENTED		2
2			10513582	B 10513582	COVER		
2			10513583	C 10513583	HOLDER		

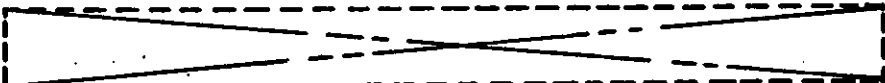

AN - AS REQUIRED, ALT - ALTERNATE, OPT - OPTIONAL, SO - SELECTION OPTIONAL

FIGURE H-5. Distribution Statement location for ADPS prepared parts lists

This sample drawing is informational only and complete to the degree necessary to illustrate a type of drawing. Actual format and drawing shall conform to the textual requirements set forth in this standard.

DOD-STD-00100D(AR)

PARTS LIST		DESIGN ACTIVITY				CAGE CODE		ORIG DATE (YY-MM-DD)		4 PL				
LIST TITLE						AUTHENTICATION			7 SHEET OF SHEETS					
									8 DWG NO.					
9 FIND NO.	10 QTY REQD	11 PRCH	12 PART OR IDENTIFYING NO.		DRAWING/DOCUMENT 13 SIZE 14 NUMBER		15 NOMENCLATURE OR DESCRIPTION				16 SUPPL LIST	17 NOTES		
<div style="border: 1px dashed black; width: 80%; margin: auto; padding: 10px;"> <!-- Content of the distribution statement area --> </div>														
18 LTD	DESCRIPTION		DATE (YY-MM-DD)	APPR	19 LTD	DESCRIPTION		DATE (YY-MM-DD)	APPR	20 LTD	DESCRIPTION		DATE (YY-MM-DD)	APPR

309

FIGURE H-6 Distribution Statement location for manually prepared parts lists

This sample drawing is informational only and complete to the degree necessary to illustrate a type of drawing. Actual format and drawing shall conform to the textual requirements set forth in this standard.

DOD-STD-00100D(AR)

THIS PAGE LEFT BLANK INTENTIONALLY

803

DOD-STD-00100D(AR)

APPENDIX I

ORDER OF PRECEDENCE FOR SELECTION OF STANDARDS AND SPECIFICATIONS

309

DOD-STD-00100D(AR)

APPENDIX I

ORDER OF PRECEDENCE FOR SELECTION OF STANDARDS AND SPECIFICATIONS

Standards and specifications shall be selected in the group and subgroup order of precedence limited to those specified below from MIL-STD-143 (paragraphs are referenced).

Order of precedence:

1. 5.1.1 Special lists. When determined necessary by the Government command or agency concerned, listing of standards and specifications for special applications may be invoked by contractual provisions. The special lists may also contain documentation that is not in standard or specification form. Such listings are to be organized in consonance with the requirements of this standard, and when used shall take precedence over the groups listed below.
2. 5.1.2 Group I. Group I covers standards and specifications individually listed in the Department of Defense Index of Specifications and Standards (DODISS).
 - a. Coordinated Federal standards and specifications
 - b. Coordinated Military standards and specifications (including JANs, ANs, and ANDs)
 - c. Industry standards and specifications (e.g., those promulgated by nationally recognized associations, committees, and technical societies) having coordinated status established under Department of Defense policies and procedures
 - d. Limited coordination military and interim Federal standards and specifications issued by the Government command or agency concerned
 - e. Industry standards and specifications having limited coordination status established by the Government command or agency concerned under Department of Defense policies and procedure
 - f. Limited coordination military and interim Federal standards and specifications issued by other Government commands or agencies
3. 5.1.3 Group II. Group II covers industry standards and specifications promulgated by nationally recognized industry associations, committees, and technical societies, for which status equivalent to military documents has not been established and which are not listed in the DODISS. Copies of industry standards and specifications are not available from the Government, and should be obtained from the association concerned.
4. 5.1.4 Group III. Group III covers Government standards and specifications other than those of the military and Federal series, and not listed in the DODISS (e.g., FAA and NASA specifications, etc.).

NOTE: Any item known to be in the military supply system which may not have been formally designated as a "standard" shall be used in preference to the creation of a new item, subject to approval of the Government Design Activity, prior to selecting from Group III.

DOD-STD-00100D(AR)

THIS PAGE LEFT BLANK INTENTIONALLY

124

DOD-STD-00100D(AR)

INDEX

- Abbreviations, 102, 102.3.3
Acceptance, 700
Accessory, 700
Additional signatures, 119.4
Allocated Configuration Identification, 700
Altered Item, 700
 Drawing, 201.4.4
 Identification of, 402.10e
Analog signal processing circuits, 112
Application block entries, 115
Approval, Revision, 504.1.3
Approved item name, 301.2
Architectural symbols, 102.1.9
Arrangement drawing, 201.3.8
Assembly, 301.4, 700
 Drawing, 201.3
 Inseparable, 201.3.4
Associated list, 700
 Identification of, 402.8
Attachment, 700
- Base Line, 700
 Allocated Base Line, 700
 Functional Base Line, 700
 Product Base Line, 700
Book-form drawing, 201.9.1
 Revision of, 505
Bulk material, 700
 Identification of, 402.16.4
- Cable assembly drawing, 201.9.6
CAD drawing signatures, 119.5
Certification data sheet, 201.9.13
Change, 402.15
 Multiple, 503.3
 Rights to data, 503.5
Classification, security, 105, 303
Code identification, 402.12
 Number, 402.1, 402.4, 402.5e
Combination of adopted items, 201.9.11
Combination of items, 700
Commercial item, 700
Commonly used words and phrases, 117.2
Company standard, 700
- Computer-aided preparation of product definition data, 101.11
Computer prepared drawing, 101.11.1
Configuration Identification, 700
Connection diagram, 201.7.2
Continuation sheets, 101.1.1
Contour definition drawing, 201.9.16
Contract, 700
Contracting officer, 700
Contractor, 700
Control drawing, 201.4
Convention, line, 101.2
Convention, screw thread, 101.7
Corner, 700
Critical safety characteristic, 700
Critical safety item, 700
Correlation drawing, 201.9.14
- Date
 Original, 402.17, 700
 Revision, 504.1.5
Deficiencies, 700
Definitions, 100.1, 201, 301, 401, 501, 601, 700
Description, revision of, 504.1.2
Design
 Activity, 700
 Agent, 700
 Responsibility transfer of, 402.9
Designation, 102
 Matched parts, 402.13.1
 Reference, electrical and electronics parts, 102.2.1
 Type, 301.3
Detail
 Assembly drawing, 201.3.1
 Assembly drawing, identification on, 402.11
 Part, title, 302.1b
Diagram
 Connection, 201.7.2
 Electrical and electronics, 103.1
 Electronic, 102.1.1
 Flowchart, 102.1.3
 Flueric power, 102.1.4
 Interconnection, 201.7.3
 Layout, electrical wiring, 102.1.5
 Logic, 102.1.2, 201.7.5

DOD-STD-00100D(AR)

INDEX (Cont'd)

Mechanical schematic, 201.7.6
 One line, 201.7.4
 Piping, 201.7.7
 Schematic, 201.7.1
 Single line, 201.7.4
 Wiring, 201.7.2
 Digital signal processing circuits, 113
 Dimensioning and Tolerancing, 101.5
 Change to, 502.1
 Distribution Statement, 700
 Distribution statements, 402.23
 Document, 700
 Document identification
 number, 401.3
 Drawing
 Altered item, 201.4.4, 201.16.2
 Application, 201.1.1
 Arrangement, 201.3.8
 Assembly, 201.3
 Book-form, 201.9.1
 Cable assembly, 201.9.6
 Camouflage basis, 201.11
 Combination of adopted
 items, 201.9.11
 Construction, 201.8
 Contour definition, 201.9.16
 Control, 201.4
 Correlation, 201.9.14
 Critical Safety Item, 402.16.7
 Dating, 119.2
 Detail, 201.2, 201.3.1
 Diagrammatic, 201.7
 Digital form, 201.9.8.1.1
 Elevation, 201.6
 Engineering, 201.1
 Envelope, 201.4.1
 Erection, 201.8.1
 Exploded assembly, 201.3.6
 Firmware, 201.16.2
 Format, 700
 Format, government, 101.1, 700
 Formulation, 201.9.15, 700
 Identification, 402
 Inseparable assembly, 201.3.4
 Installation, 201.5
 Installation assembly, 201.3.5
 Installation control, 201.4.7
 Installation instruction,
 201.9.10.3
 Interface control, 201.4.6
 Kit, 201.9.10
 Layout, 201.10
 Marine, 201.9.12
 Matched part, 201.3.7
 Materials, 104
 Modification, 201.9.17
 Monodetail, 201.2.1
 Multi-detail, 201.2.2
 Multi-view, 101.3
 Non-part, 700
 Notes, 117
 Number, 401.4, 402.5
 Numerical control, 201.9.3
 Optical element, 201.9.4
 Optical system, 201.9.4
 Original, 700
 Package content, 201.15
 Part, 700
 Photo-assembly, 201.3.3
 Plan, 201.8.2
 Plat plan, 201.8.3
 Practices, 502.3
 Printed wiring master, 201.9.9
 Printed wiring master pattern,
 201.9.8
 Redrawn, 119.1.2
 Replacement, 700
 Rework, 201.9.10.2
 Selected item, 201.4.5
 Sensitive electronic devices,
 402.16.8
 Ship equipment, 201.9.12
 Site, 201.8.4
 Size, 101.1
 Source control, 201.4.3, 402.9.1
 Software and Firmware Data, 201.16
 Software Control, 201.16.1
 Special purpose, 201.9
 Specification control, 201.4.2
 Tabulated assembly, 201.3.2
 Tabulated detail, 201.2.3
 Title, 301.1
 Title, creation of, 302
 Tube bend, 201.2.4
 Undimensioned, 201.9.7
 Vehicle (top assembly), 201.13
 Vehicle camouflage pattern, 201.14
 Vicinity, 201.8.4
 Wiring harness, 201.9.5
 Duplicate Original, 402.24, 700

DOD-STD-00100D(AR)

INDEX (Cont'd)

Edge, 700
 Electrical
 Diagram, 103
 Reference designation, 102.2.1
 Symbols (graphic), 102.1
 Wiring symbols (architectural), 102.1.5
 Wiring symbols (graphic), 102.1.10
 Elevation drawing, 201.6
 Electronics
 Diagrams, 103.1
 Symbols (graphic), 102.1.1
 End-product, 700
 Engineering
 Data, 700
 Drawing, 201.1
 Drawing format, 101.1
 Envelope drawing, 201.4.1
 Erection drawing, 201.8.1
 Exploded assembly drawing, 201.3.6
 Exterior corners and edges, 700
 Exterior Edge/Corner Break, 700

 First tier, 700
 Formal Engineering Change Control, 700
 Formulation, 700
 Full Scale Development Phase, 700
 Functional Configuration Identification, 700

 Gears, 101.8
 Government drawing format, 700
 Government procurement quality assurance, 700
 Government standard, 700
 Graphic symbols, 102
 Electrical, 102.1.1
 Electrical wiring (architectural), 102.1.5
 Electronic, 102.1.1
 Flowchart, 102.1.3
 Flueric power diagrams, 102.1.4
 Group, 700
 Group Identification, 402.16.1
 Logic, 102.1.2
 Mechanical, 102.1.6, 102.1.7

 Identification
 Associated list, 402.8
 Bulk material, 402.16.4
 Code, 402.12, 402.9.3
 Detail assembly drawing, 402.11
 Find number, 402.11
 Formulation, 402.16.3
 Group, 402.16.1
 Installation drawing, 402.11
 Item, 402.6
 Maintaining design activities identities, 402.9.2
 Material, 402.16
 Multi-detail drawing, 402.11
 New, 402.14
 Nuclear hardness critical items, 402.16.6
 Number, 401.3
 On drawings, 402.11
 Optional parts, 402.22
 Parenthetical, 402.11.2
 Precious metals, 402.16.5
 Processes, 402.16
 Protective treatment, 402.16
 Reference, 114
 Referenced documents, 402.3
 Requirements, 402
 Revision, 503.1
 Source control drawing, 402.10 (Note 2)
 Specification control drawing, 402.10 (Note 1)
 Tabulated drawing, 402.11
 Indefinite terms, 117.4
 Industry Standards, 700
 Initial and Signature Block, 119.3
 Inseparable assembly, 201.3.4, 402.13.3
 Installation assembly drawing, 201.3.5
 Installation control drawing, 201.4.7
 Installation drawing, 201.5
 Identification on, 402.11
 Interchangeable item, 700
 Interconnection diagram, 201.7.3
 Interface control drawing, 201.4.6
 Interior corners and edges, 700
 Isometric and pictorial views, 101.3.1
 Item, 700
 Altered, 700
 Commercial, 700

DOD-STD-00100D(AR)

INDEX (Cont'd)

Identification, 402.10
 Altered, 402.10e
 Approved specification, 402.10b
 Approved standard, 402.10a
 Selected, 402.10e
 Item, interchangeable, 700
 Item name, approved, 301.2
 Item, Non-interchangeable, 402.20.2
 Item replacement notation, 402.20

 Kit drawing, 201.9.10
 Accessory, 201.9.10b
 Hardware conversion, 201.9.10d
 Modification, 201.9.10a
 Software conversion, 201.9.10c

 Lay, 101.6
 Letter
 Revision, 503.2
 Symbols, 102, 102.3.1
 Lettering, 101.2
 Level, 700
 Limited production, 700
 Line conventions, 101.2
 List
 Additional Authorized List, 604.2
 Associated, 700
 Automatic data processing system preparation, 602.1.2
 Basic Issue Items, 604.1
 Integral, 201.1.2
 Manual Preparation, 602.1.1
 On Vehicle Equipment, 604
 Parts, 601.1
 Parts, preparation of, 602.1, 603
 Parts, separate, 601.1
 Revisions, 602.3
 Special Tool Set List, 605
 Wiring, 201.9.2
 Location of notes, 117.5
 Logic diagrams, 201.7.5
 Logic symbols (graphic), 102.1.2

 Manufacturer, 700
 Marking and location, 108
 CARC painted items, 108.1.3.2
 Matched parts, 108.1.2
 Requirements, 108.1
 Rubber products, 108.1.3.1
 SED (Sensitive Electronic Device), 108.1.3.3
 Matched part, 700
 Designation, 402.13.1
 Drawing, 201.3.7
 Material
 Bulk, 700
 Engineering drawing, 104
 Identification of, 402.16
 Notes, 118
 Radioactive, 107
 Mathematical signs, 102.3.2
 Mechanical
 Schematic diagram, 201.7.6
 Springs, 101.9
 Symbols, 102.1.6
 Aerospacecraft, 102.1.7
 Metric values, 101.4
 Microcircuits, 116
 Modification drawing, 201.9.17
 Module, 700, 111
 Monodetail drawing, 201.2.1
 Multi-detail drawing, 201.2.2
 Multi-detail drawing, identification on, 402.11
 Multiple changes, 503.3
 Multi-sheet drawing, revision of, 505
 Multi-view drawing, 101.3

 Name, item, approved, 301.2
 New identification, 402.14
 Nondestructive testing symbols, 101.1.12
 Non-part drawing, 700
 Note contents, 117.6
 Number
 Code identification, 401.2, 402.4, 402.10c

DOD-STD-00100D(AR)

INDEX (Cont'd)

Document identification, 401.3
 Drawing, 401.4, 402.5
 Find, 401.6
 Part, 401.5, 402.6, 402.12, 402.13
 Records, 402.7
 Numerical control drawing, 201.9.3

 Obsolete items, 402.20.3
 Officer, contracting, 700
 One-line diagram, 201.7.4
 Optical
 Element, 101.10
 Element drawing, 201.9.4
 System, 101.10
 System drawing, 201.9.4
 Order of precedence of spec/standards,
 402.18
 Optional/Alternative Designs, 109
 Original date, 402.17
 Original drawing, 700
 Duplicate, 104.1

 Parenthetical identifier,
 402.11.2
 Part, 700
 Depiction, 110
 Designation, matched,
 402.13.1
 Drawing, 700
 List, 601.1
 List format, 603.1
 Matched, 700
 Number, 401.5, 402.6,
 402.10, 402.12
 Symmetrically opposite,
 402.13.2, 700
 Photo-assembly drawing,
 201.3.3
 Piping diagram, 201.7.7
 Plan drawing, 201.8.2
 Plat plan drawing, 201.8.3
 Printed wiring master
 drawing, 201.9.9
 Printed wiring master
 pattern drawing, 201.9.9
 Process, identification of,
 402.16
 Product Configuration
 Identification, 700
 Production, 700

 Production, limited, 700
 Protective treatment, identification
 of, 402.16
 Proved, 700

 Quality assurance, 700

 Recording revisions, 504
 Redrawn or replaced drawings, 506
 Reference designations, electrical,
 electronic parts, 102.2.1
 Referenced documents, identification
 of, 402.3
 Reidentification, 402.10.1
 Repairable, 700
 Replacement drawing, 700
 Revision, 700, 500, 501, 502
 Additions, 503.4
 Approval, 504.1.3
 Authorization, 700
 Block, 504.1
 Book-form drawing, 505
 Crossing out, 502.2
 Computer generated/revised drawings,
 505.4
 Date, 504.1.5
 Description, 504.1.2
 Dimensions, 502.1
 Identification, 503.1
 Letter, 503.2, 504.1.1
 Multi-sheet drawing, 505
 Recording, 504
 Required, 503.6
 Separating, 504.1.6
 Symbol, 700
 Zoning, 504.1.4
 Rights to data, 503.5

 Scale, 106
 Drawings not to, 106.3
 Dimensions not to, 106.4
 Fractional method, 106.2.1
 Indication of, 106.2
 Schematic diagrams, 201.7.1
 Schematic, mechanical, 201.7.6
 Screw thread representation, 101.7
 Security, 105, 303
 Selected item drawing, 201.4.5
 Selected item identification, 402.10e
 Set, 700

DOD-STD-00100D(AR)

INDEX (Cont'd)

Sheet, certification data,
 201.9.13
 Sheet form standard, 700
 Ship equipment drawing, 201.9.12
 Signing and dating drawings, 119
 Signing drawings, 119.1
 Signing for another, 119.1.1
 Site drawing, 201.8.4
 Size and format of engineering
 drawings, 101.1
 Source control drawing, 201.4.3,
 402.10 (Note 2), 402.11.1
 Specification control drawing,
 201.4.2, 402.10 (Note 1), 402.11.1
 Springs, 101.9
 Standard, 700
 Company, 700
 Design Activity, 700
 Government, 700
 Industry, 700
 Non-government, 700
 Sheet Form, 700
 Structural symbols, 102.1.8
 Subassembly, 700
 Subcontractor, 700
 Superseded items, 402.20.4
 Surface roughness, waviness and
 lay, 101.6
 Symbols
 Aerospacecraft, 102.1.7
 Architectural, 102.1.9
 Electrical, 102.1.1
 Electrical wiring, 102.1.5
 Electrical wiring (ships' plane),
 102.1.10
 Electronic, 102.1.1
 Flowchart, 102.1.3
 Flueric power, 102.1.4
 Interface Control Identification,
 402.19
 Letter, 102.3.1
 Logic, 102.1.2
 Mathematical signs, 102.3.2
 Mechanical, 102.1.6
 Nondestructive testing, 102.1.12
 Revision, 700
 Structural, 102.1.8
 Surface texture, 101.6.1
 Welding, 102.1.11

 Symmetrically opposite parts,
 402.13.2, 700
 System, 700

 Tabulated
 Assembly drawing, 201.3.2
 Detail drawing, 201.2.3
 Drawing, identification, 402.11
 Title
 Drawing, 301.1
 Drawing, creation of, 302
 Detail part, 302.1b
 Kit drawing, 304
 Tolerancing, 101.5
 Transfer, design responsibility,
 402.9
 Tube bend drawing, 201.2.4
 Type designator, 301.3

 Unit, 700
 Undimensioned drawing, 201.9.7

 Validation, 700
 Vendor, 700
 Vicinity plan drawing, 201.8.4

 Waviness, 101.6
 Welding symbols, 102.1.11
 Wiring
 Harness drawing, 201.9.5
 Diagram, 201.7.2
 List, 201.9.2

 Zoning, revision, 504.1.4

318

INSTRUCTIONS: In a continuing effort to make our standardization documents better, the DoD provides this form for use in submitting comments and suggestions for improvements. All users of military standardization documents are invited to provide suggestions. This form may be detached, folded along the lines indicated, taped along the loose edge (*DO NOT STAPLE*), and mailed. In block 5, be as specific as possible about particular problem areas such as wording which required interpretation, was too rigid, restrictive, loose, ambiguous, or was incompatible, and give proposed wording changes which would alleviate the problems. Enter in block 6 any remarks not related to a specific paragraph of the document. If block 7 is filled out, an acknowledgement will be mailed to you within 30 days to let you know that your comments were received and are being considered.

NOTE: This form may not be used to request copies of documents, nor to request waivers, deviations, or clarification of specification requirements on current contracts. Comments submitted on this form do not constitute or imply authorization to waive any portion of the referenced document(s) or to amend contractual requirements.

(Fold along this line)

(Fold along this line)

DEPARTMENT OF THE ARMY



NO POSTAGE
NECESSARY
IF MAILED
IN THE
UNITED STATES

OFFICIAL BUSINESS
PENALTY FOR PRIVATE USE \$300

BUSINESS REPLY MAIL
FIRST CLASS PERMIT NO. 12062 WASHINGTON D. C.

POSTAGE WILL BE PAID BY THE DEPARTMENT OF THE ARMY

Commander
U.S. Army Armament Research, Development and
Engineering Center
ATTN: SMCAR-ESC-S
Picatinny Arsenal, NJ 07806-5000

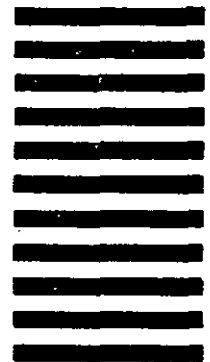

319

STANDARDIZATION DOCUMENT IMPROVEMENT PROPOSAL

(See Instructions - Reverse Side)

1. DOCUMENT NUMBER DOD-STD-00100D (AR)		2. DOCUMENT TITLE ENGINEERING DRAWING PRACTICES	
3a. NAME OF SUBMITTING ORGANIZATION		4. TYPE OF ORGANIZATION (Mark one)	
b. ADDRESS (Street, City, State, ZIP Code)		<input type="checkbox"/> VENDOR	
		<input type="checkbox"/> USER	
		<input type="checkbox"/> MANUFACTURER	
		<input type="checkbox"/> OTHER (Specify): _____	
5. PROBLEM AREAS			
a. Paragraph Number and Wording:			
b. Recommended Wording:			
c. Reason/Rationale for Recommendation:			
6. REMARKS			
7a. NAME OF SUBMITTER (Last, First, MI) - Optional		b. WORK TELEPHONE NUMBER (Include Area Code) - Optional	
c. MAILING ADDRESS (Street, City, State, ZIP Code) - Optional		8. DATE OF SUBMISSION (YYMMDD)	