

DOD-L-81846B  
 3 September 1986  
 SUPERSEDING  
 MIL-L-81846A  
 27 December 1984

## LUBRICATING OIL, INSTRUMENT, BALL BEARING, HIGH FLASH POINT

This specification is approved for use  
 by all Departments and Agencies of the  
 Department of Defense.

### 1. SCOPE

1.1 Scope. This specification covers the requirements for one grade of a specialty lubricating oil for use in precision instrument and miniature ball bearings.

### 2. APPLICABLE DOCUMENTS

#### 2.1 Government documents.

2.1.1 Specifications, standards, and handbooks. The following specifications, standards, and handbooks form a part of this specification to the extent specified herein. Unless otherwise specified, the issues of these documents shall be those listed in the issue of the Department of Defense Index of Specifications and Standards (DODISS) and supplement thereto, cited in the solicitation.

### SPECIFICATIONS

#### FEDERAL

P-D-680	-	Dry Cleaning Solvent.
QQ-B-626	-	Brass, Leaded and Nonleaded: Rod, Shapes, Forgings, and Flat Products with Finished Edges (Bar and Strip).
QQ-S-766	-	Steel Plates, Sheets, and Strip - Corrosion Resisting.

#### MILITARY

MIL-S-13282	-	Silver and Silver Alloy.
MIL-C-81302	-	Cleaning Compound, Solvent, Trichlorotrifluoroethane.

Beneficial comments (recommendations, additions, deletions) and any pertinent data which may be of use in improving this document should be addressed to: System Engineering and Standardization Department (Code 93), Naval Air Engineering Center, Lakehurst, NJ 08733-5100, by using the self-addressed Standardization Document Improvement Proposal (DD Form 1426) appearing at the end of this document or by letter.
---

DOD-L-81846B

## STANDARDS

## FEDERAL

- FED-STD-313 - Material Safety Data Sheets, Preparation and Submission of.
- FED-STD-791 - Lubricants, Liquid Fuels and Related Products, Methods of Testing.

## MILITARY

- MIL-STD-105 - Sampling Procedures and Tables for Inspection by Attributes.
- MIL-STD-290 - Packaging of Petroleum and Related Products.

2.1.2 Other Government publications. The following other Government publication forms a part of this specification to the extent specified herein. Unless otherwise specified, the issues shall be those in effect on the date of the solicitation.

## PUBLICATIONS

## CODE OF FEDERAL REGULATIONS

- 49 CFR - Transportation - Hazardous Materials.

(Applications for copies should be addressed to the Superintendent of Documents, Government Printing Office, Washington, DC 20402.)

(Copies of specifications, standards, handbooks, drawings, and publications required by manufacturers in connection with specific acquisition functions should be obtained from the contracting activity or as directed by the contracting officer.)

2.2 Other publications. The following documents form a part of this specification to the extent specified herein. The issues of the documents which are indicated as DoD adopted shall be the issue listed in the current DoDISS and the supplement thereto, if applicable.

## AMERICAN SOCIETY FOR TESTING AND MATERIALS (ASTM)

- ASTM A 109 - Steel, Carbon, Cold-Rolled Strip
- ASTM A 331 - Steel Bars, Alloy, Cold-Finished
- ASTM A 366 - Steel, Carbon, Cold-Rolled Sheet, Commercial
- ASTM D 92 - Flash and Fire Points by Cleveland Open Cup.
- ASTM D 97 - Pour Point of Petroleum Oils.
- ASTM D 445 - Kinetic Viscosity of Transparent and Opaque Liquids (and the Calculation of Dynamic Viscosity).
- ASTM D 972 - Evaporation Loss of Lubricating Greases and Oils.
- ASTM D 974 - Neutralization Number by Color - Indicator Titration.
- ASTM D 1500 - ASTM Color of Petroleum Products (ASTM Color Scale).
- ASTM D 1748 - Rust Protection by Metal Preservatives in the Humidity Cabinet.

(Application for copies should be addressed to the American Society for Testing and Materials, 1916 Race Street, Philadelphia, PA 19103.)

DOD-L-81846B

## AMERICAN NATIONAL STANDARDS INSTITUTE (ANSI)

ANSI Z129.1 - American National Standard for the Precautionary Labeling of Hazardous Industrial Chemicals.

(Application for copies should be addressed to the American National Standards Institute, 1430 Broadway, New York, NY 10018.)

(Nongovernment standards and other publications are normally available from the organizations which prepare or which distribute the documents. These documents also may be available in or through libraries of other informational services.)

2.3 Order of precedence. In the event of a conflict between the text of this specification and the references cited herein (except for associated detail specifications, specification sheets or MS standards), the text of this specification shall take precedence. Nothing in this specification, however, shall supersede applicable laws and regulations unless a specific exemption has been obtained.

### 3. REQUIREMENTS

\* 3.1 First Article. When specified, a sample shall be subjected to first article inspection (see 4.3 and 6.3).

3.2 Composition. The lubricating oil shall conform to the composition in percent by weight specified in Table I. Extreme care should be exercised to assure that the lubricating oil contains no silicone defoamer compounds.

3.3 Physical properties. The physical properties of the lubricating oil shall be in accordance with physical properties appearing in Table II, when tested as specified in 4.6.2 through 4.6.7.

3.4 Material safety data sheet. Material safety data sheets shall be prepared and submitted in accordance with FED-STD-313. Material safety data sheets shall also be forwarded as specified in 4.3.2. The oil shall have no adverse effect on the health of personnel when used for its intended purpose. Questions pertinent to this effect shall be referred by the contracting activity to the appropriate departmental medical service who will act as an advisor to the contracting agency (see 4.3.2 and 6.2.1e).

3.5 Workmanship. The lubricating oil shall be a homogeneous, clear and bright liquid free from any visible impurities. Immediately before the oil is packaged, it shall be passed through a 0.5 micrometer membrane filter of an ester-compatible filter medium (see 6.5). Filtration through glass fiber filters is not acceptable.

### 4. QUALITY ASSURANCE PROVISIONS

4.1 Responsibility for inspection. Unless otherwise specified in the contract or purchase order, the contractor is responsible for the performance of all inspection requirements as specified herein. Except as otherwise specified in the contract or purchase order, the contractor may use his own or any other facilities suitable for the performance of the inspection requirements specified herein, unless disapproved by the Government. The Government reserves the right to perform any of the inspections set forth in the specification where such inspections are deemed necessary to assure the specified requirements.

DOD-L-81846B

4.1.1 Responsibility for compliance. The oil must meet all requirements of sections 3 and 5. The inspection set forth in this specification shall become a part of the contractor's overall inspection system or quality program. The absence of any inspection requirements in the specifications shall not relieve the contractor of the responsibility of assuring that all products or supplies submitted to the Government for acceptance comply with all requirements of the contract. Sampling in quality conformance does not authorize submission of known defective material, either indicated or actual, nor does it commit the Government to acceptance of defective material.

\* 4.2 Classification of inspections. The inspection requirements specified herein are classified as follows:

- a. First article inspection (see 4.3).
- b. Quality conformance inspection (see 4.4).

\* 4.3 First article inspection. The first article inspection shall consist of performance of any test or examination deemed necessary to determine that the first article sample (see 4.3.1) complies with all the requirements for the physical properties specified in Table II, when tested in accordance with the inspection methods specified in Table IV and 4.6.3 through 4.6.7(see 6.2.2).

\* 4.3.1 First articles samples. The first article samples shall consist of two, 1 liter (one-quart) containers of the lubricating oil. The samples shall be forwarded to the Aircraft and Crew Systems Technology Directorate, Code 60612, Naval Air Development Center, Warminster, PA 18974. The samples shall be plainly identified by securely attached durable tags or labels, marked with the following information:

Sample for first article inspection.  
 LUBRICATING OIL, INSTRUMENT, BALL BEARING, HIGH FLASH POINT  
 Name of manufacturer.  
 Location and identity of the plant.  
 Product code number.  
 Source, type and composition of ingredients used.  
 Batch number.  
 Date of manufacture.  
 Submitted by (name) (date) for first article inspection in  
 accordance with DOD-L-81846B under authorization of (reference  
 authorizing letter) (see 6.3).

4.4 Quality conformance inspection. The quality conformance inspection of the lubricating oil shall consist of tests of samples from 4.4.2.2 in accordance with Table III and an examination of samples from 4.4.2.1 for conformance with 4.6.1. Samples shall be labeled completely with information identifying the purpose of the sample, name of product, specification number, date of manufacture, date of sampling, and contract number. Individual samples shall not be mixed, shall be placed in separate air-tight and water-tight containers, and shall be nearly filled, covered and sealed to prevent atmospheric effects.

4.4.1 Lot formation. A lot shall consist of all the lubricating oil produced by one manufacturer, at one plant, from the same materials and under essentially the same conditions, provided the operation is continuous and does not exceed a 24 hour period. In the event the process is a batch operation, each batch shall constitute a lot (see 6.4).

#### 4.4.2 Sampling.

4.4.2.1 For examination of filled containers. A random sample of filled containers, fully prepared for delivery, shall be selected from each lot of lubricating oil in accordance with MIL-STD-105, inspection level II with an acceptable quality level (AQL) of 2.5 percent defective.

4.4.2.2 For tests. The sample for tests shall be one container of the lubricating oil taken at random from filled containers from each lot of lubricating oil. The lot shall be unacceptable if the sample fails to comply with any of the requirements for the tests specified in 4.6.2 through 4.6.7.

#### 4.5 Inspection conditions.

4.5.1 Test conditions. Test conditions shall be in accordance with 4.6 and the physical values specified in Table II apply to the average of determinations made on the sample.

#### 4.6 Methods of examinations and tests.

4.6.1 Examinations. Each of the filled containers, selected in accordance with 4.4.2.1, shall be examined for defects of the container and closure, for evidence of leakage and for unsatisfactory markings to determine conformance with 5.1 through 5.3.2. Each sample container shall also be weighed to determine the amount of contents. If the number of defective containers exceeds the acceptance number of the sampling plan specified in 4.4.2.1, the lot shall be rejected.

4.6.2 Tests. Tests shall be performed in accordance with Table IV and 4.6.3 through 4.6.6 to determine conformance with the requirements specified in 3.3.

#### 4.6.3 Protection.

4.6.3.1 Preparation of panels. Five panels shall be cut from steel conforming to ASTM A 109 or ASTM A 366. The size of the panels and the location of the holes shall be as specified in Figure A-7 of ASTM D 1748. All burrs, sharp edges and corners, including edges of holes, shall be removed. Immediately prior to use, the panels shall be polished to a high luster with 3/0 emery paper. The panels shall be cleaned by washing in solvent conforming to P-D-680, type I, drained thoroughly, followed by rinsing in boiling 95 percent methanol. After cleaning, the panels shall be cooled in a desiccator. Care must be taken during the cleaning and preparation that the surfaces are not contaminated with fingerprints. The panels shall be handled with tongs during the cleaning operation and with hooks during and after dipping.

4.6.3.2 Procedure. The five panels shall be dipped in a sample of lubricating oil, maintained at  $25 \pm 1^\circ\text{C}$ , removed, and allowed to drain from glass, monel, or stainless steel supports at the same temperature. At the end of this period, the panels shall be suspended in a humidity cabinet conforming to ASTM D 1748 for a period of 200 hours and in such a manner that the drippings from the supports do not fall on the panels. The humidity cabinet shall be maintained at 100 percent humidity and a temperature of  $49 \pm 1^\circ\text{C}$  for the 200 hour exposure period. The

panels shall be removed from the cabinet, cleaned with naphtha and examined (see Table II).

#### 4.6.4 Corrosivity test.

##### 4.6.4.1 Preparation of panels.

4.6.4.1.1 Steel discs. Three discs, 12.7 mm thick, shall be cut from 25.4 mm diameter bar stock conforming to ASTM A 331, composition E52100. The discs shall be heat treated to a Rockwell C-62 hardness. (Rollers that may be obtained from roller bearings, and that have similar chemical, physical, and dimensional properties to the above bar stock after heat treatment, can be substituted for the formation of the discs. In this case, no further treatment is necessary.) The discs shall now be slowly surface ground on one side to a finish of less than 0.51 micrometers rms. If coolant is used in grinding, the discs shall be slushed in absolute methanol. The discs shall then be abraded on the surface-ground side by successive applications of emery polishing paper graded 1/0, 2/0, 3/0 and finally 4/0. There shall be no scratches remaining from papers more coarse than 4/0. Paper incorporating iron oxide as the polishing medium, and wet-dry type papers, shall not be used. The discs shall be wiped clean with sterile absorbent gauze and examined under 10X magnification for any signs of corrosion or other defects. Defective specimens shall not be used. The discs shall be stored in a desiccator containing silica gel until ready for use.

4.6.4.1.2 Brass clips. Three clips shall be fabricated from commercial 0.5715 mm brass sheet conforming to QQ-B-626, spring temper. The size and shape of the clips shall be as illustrated in Figure 1. The clips shall then be immersed for 20 seconds in the following etching solution:

- 450 ml water
- 225 ml concentrated nitric acid
- 300 ml concentrated sulfuric acid
- 8 ml concentrated hydrochloric acid

After etching, the clips shall be washed in cold running tap water until free of acid and finally dried with acetone. The clips shall then be stored in a desiccator containing silica gel desiccant until ready for use.

4.6.4.2 Procedure. The three discs shall be coated with the test oil by dipping a stirring rod in the test oil and allowing the oil from the rod to drop on the polished side of the discs. The drops shall be spread so as to completely cover the discs. The brass clips shall then be clamped over the coated discs and the assemblies placed in a test chamber maintained at 26.7°C and 50 percent relative humidity for a period of 35 days. After exposure, the assemblies shall be removed and the area covered by the brass clips outlined on the discs using the clips as templates. The clips shall then be removed, the test oil wiped from the discs and the discs examined (see Table II).

4.6.5 Corrosion and oxidation stability. The corrosion and oxidation stability shall be performed at 177°C in accordance with method 5308 of FED-STD-791 with the following modifications: An electrolytic grade silver (conforming to MIL-S-13282, grade A) test square shall be substituted for the cadmium plated steel square. The

aluminum test square shall be replaced with a square conforming to ASTM A 331, composition FS E52100. The magnesium square shall be replaced with a type 410 steel square conforming to QQ-S-766. Allow air flow through the sample at a rate of  $3 \pm 0.2$  liters per hour for 72 hours. The viscosity at  $38^{\circ}\text{C}$  shall be performed within six hours of the completion of the oxidation test period. The sludge content after the  $177^{\circ}\text{C}$  test shall be determined as follows: The oil shall be decanted from the test tube through a preweighed 10 micrometer membrane filter fabricated from an ester-compatible filter medium (see 6.5) and the filtrate separately retained for measurement of viscosity and neutralization number tests. The test tube shall be rinsed with petroleum ether until clean and the washings decanted through the membrane filter. Finally, the filter shall be rinsed with at least 2 portions of petroleum ether to remove the remaining oil. The filter shall be dried for 20 minutes at  $50^{\circ}\text{C}$  and reweighed.

4.6.6 Thin film stability. The stainless steel planchets (5 cm diameter and 1 cm deep) used in this test (see 6.8) shall be cleaned before use as follows: they shall be rinsed in solvent conforming to P-D-680 (Type I), drained thoroughly, rinsed in boiling 95% methanol, and dried at  $80^{\circ} - 100^{\circ}\text{C}$  for 5 minutes. A  $350 \pm 50$  milligram sample of the lubricating oil shall be transferred to a planchet and then held for 6 1/2 hours in a gravity convection oven maintained at  $177^{\circ} \pm 2^{\circ}\text{C}$ . The weight loss shall be determined and the final appearance of the oil noted (see Table II).

4.6.7 Particulate matter. Each of the filled containers selected in accordance with 4.4.2.1, shall be examined for particulate matter. The oil shall be passed through a 0.5 micrometer membrane filter fabricated from an ester-compatible filter medium. Presence of particulate matter larger than 0.5 micrometers shall be basis for failure.

## 5. PACKAGING

5.1 Preservation. Unless otherwise specified, preservation shall be level A (see 6.2.1).

5.1.1 Level A. The oil, immediately before packaging, shall be passed through a 0.5 micrometer membrane filter fabricated from an ester-compatible filter medium (see 6.5). Filtration through glass fiber filters shall not be acceptable. The lubricating oil shall be packaged in 118.29 ml (4 ounce) wide-mouthed brown glass bottles. Screwcaps shall be fitted with a polyethylene or polypropylene liner. The caps shall be compatible with diester oil. The bottles shall be rinsed with filtered MIL-C-81302 trichlorotrifluoroethane and dried with clean filtered air.

5.2 Packing. Packing shall be in accordance with MIL-STD-290. The type and size of the containers and the level of packing shall be as specified by the acquiring activity (see 6.2.1).

5.3 Marking. All unit, intermediate and shipping containers shall be marked in accordance with MIL-STD-290 and Title 49 of the Code of Federal Regulations and any other additional special markings specified by the acquiring activity (see 6.2.1c). All unit and intermediate packs of toxic and hazardous chemicals and materials shall also be labeled in accordance with the applicable laws, statutes, regulations or ordinances, including Federal, State, and Municipal requirements. In addition unit and intermediate containers, including unit containers that serve as shipping containers, such as pails and drums, shall be marked with the applicable precautionary information detailed in ANSI Z39.1

## 6. NOTES

6.1 Intended use. This oil is intended for use in precision instrument and miniature ball bearings, for the temperature range of -55°C to 150°C.

### 6.2 Ordering data.

\* 6.2.1 Acquisition requirements. Acquisition documents should specify the following:

- a. Title, number and date of this specification.
- b. Quantity desired, container size.
- c. Special marking, if required (see 5.3).
- d. Applicable levels of preservation and packing (see 5.1 and 5.2).
- e. FAR clause 52.223-3.
- f. Whether first article is required (see 3.1 and 6.3).

\* 6.2.2. Data requirements. When this specification is used in an acquisition which incorporates a DD Form 1423, Contract Data Requirements List (CDRL), the data requirements identified below shall be developed as specified by an approved Data Item Description (DD Form 1664) and delivered in accordance with the approved CDRL incorporated into the contract. When the provisions of DOD FAR Supplement Part 27, Sub-Part 27.410-6 are invoked and the DD Form 1423 is not used, the data specified below shall be delivered by the contractor in accordance with the contract or purchase order requirements. Deliverable data required by this specification is cited in the following paragraphs:

<u>Paragraph no.</u>	<u>Data requirements</u>	<u>Applicable DID no.</u>
4.3	First article inspection reports.	DI-T-4902

(Copies of data item descriptions required by contractors in connection with specific acquisition functions should be obtained from the Naval Publications and Forms Center or as directed by the contracting officer.)

\* 6.3 First article. When a first article inspection is required, the lubricating oil will be tested and should be a sample selected from the first production lot. The first article should consist of two, 1 liter (one-quart) containers of the lubricating oil. The contracting officer should include specific instructions regarding examinations, tests and approval of the first article. When a contractor is in continuous production of the lubricant from contract to contract, consideration should be given to waive the first article inspection. If inspection is required, indicate the following:



- a. If first article inspections are conducted at the contractor's plant or a Government approved laboratory, an inspection report shall be forwarded to the acquiring activity for verification (see 4.3).
- b. That the approval of first article samples or the waiving of the first article inspection shall not relieve the contractor of his obligation to fulfill all other requirements of the specification and contract.

6.4 Batch. A batch is defined as that quantity of material which has been manufactured by some unit chemical process and subjected to some physical mixing operation intended to make the final product substantially uniform.

6.5 Filtration benefits. To obtain maximum benefit from filtration through filters (0.5 micrometers or smaller) and to maintain product cleanliness, the filling operation should take place under clean room conditions, or in a laminar flow clean bench. The filter membrane shall be fabricated from an ester-compatible filter medium. Glass fiber filters are not acceptable.

#### 6.6 Barium dinonylnaphthalene sulfonate formulation.

6.6.1 Method 1. The barium dinonylnaphthalene sulfonate to be used in the formula of Table I should be dissolved in heptane or other distillable light petroleum solvent. The heptane or light petroleum fraction solution of the barium dinonylnaphthalene sulfonate, usually supplied in 50 percent concentration, should be added to a sufficient amount of percolated bis (2-ethylhexyl) azelate to make about a 50 percent concentrate after the solvent is removed by stripping. The solvent is then boiled off in a rotary flask evaporator using a hot water bath or by other appropriate means. An analysis of the barium content of the azelate concentrate must be performed so that the correct proportion of the additive may be incorporated into the final formulation. After the evaporation of the heptane, the final formulation may then be blended in the proportions given in Table I.

6.6.2 Method 2. The barium dinonylnaphthalene sulfonate may be introduced into the formulation as a 50 percent solution in either bis (2-ethylhexyl) azelate, or bis (2-ethylhexyl) sebacate (marketed by the R.T. Vanderbilt Co. as NA-SUL-BSN). When an azelate concentrate is employed, the ester proportions listed in Table I will pertain. When a sebacate concentrate is employed, the additional diester content required by the formulation will be made up with bis (2-ethylhexyl) azelate. The presence of the sebacate will have only a very small effect on the viscosity of the lubricant; however, to ensure that the viscosity limits delineated in Table II are met, a variation of  $\pm 1.4$  percent in the diester and pentaerythritol ester contents is permitted.

6.7 Material characteristics. Materials listed in Table I from other suppliers have occasionally resulted in an unsatisfactory formulation which will not conform to Section 3 requirements. Use of the suggested sources does not guarantee a satisfactory product. It is suggested that materials, footnotes 1/, 2/, and 5/ be separately passed through a column of activated "Florisil" to remove possible polar contaminants prior to formulation.

6.8 Source of plachets. Plachets may be obtained from Laboratory Products, P. O. Box 1802, Ann Arbor, MI 48106.

\* 6.9 Changes from previous issue. The margins of this specification are marked with asterisks to indicate where changes (additions, modifications, corrections, deletions) from the previous issue were made. This was done as a convience only and the Government assumes no liability whatsoever for any inaccuracies in these notations. Bidders and contractors are cautioned to evaluate the requirement of this document based on the entire content irrespective of the marginal notations and relationship to the last previous issue.

6.10 Subject term (key word) listing

Ball bearing lubricant  
Ball bearing oil  
High flash point, lubricating oil  
Lubricating oil  
Oil  
Precision instrument lubricant  
Precision instrument oil

Custodians:

Army - ME  
Navy - AS  
Air Force - 20

Preparing activity:

Navy - AS

(Project No. 9150-0767)

Review activities:

Army - CR  
Navy - SH  
Air Force - 99  
DLA - GS

User activities:

Navy - OS  
Army - AR

TABLE I. Composition of lubricating oil.

Ingredient	Percent by weight
Bis (2-ethylhexyl) azelate <u>1/</u>	63.3 ± 0.4
Pentaerythritol tetracaproate <u>2/</u>	34.5 ± 0.4
Barium dinonylnaphthalene sulfonate <u>3/</u> <u>6/</u>	1.0 ± 0.1
Alkylated phenylalphanaphthyl amine <u>4/</u>	1.0 ± 0.1
Benzotriazole <u>5/</u>	0.20 ± 0.05

1/ Emery Industries or equivalent (see 6.7).

2/ Hercules Powder Company, "Hercolube A", or equivalent (see 6.7).

3/ R. T. Vanderbilt Company, "NA-SUL-BSN", or equivalent.

4/ Geigy Chemical Company "Antioxidant LO-6", or equivalent.

5/ Eastman Kodak, Sherwin Williams, or equivalent (see 6.7).

6/ See 6.6.

TABLE II. Physical properties.

Characteristic	Requirements
Color, maximum	5.0 <u>1/</u>
Appearance	Clear and bright
Neutralization number	For reference only <u>2/</u>
Particulate matter, micrometers, maximum	0.5 <u>3/</u>
Viscosity, meters <sup>2</sup> per second (m <sup>2</sup> /s), at: 98.9°C, minimum 37.8°C, minimum -53.9°C, maximum	3.45 14.0 <u>2/</u> 13,000
Pour point, °C, maximum	-57
Low temperature stability, °C, maximum	-57 <u>4/</u>
Evaporation, percent, weight loss, at 176°C, maximum, in: 6-1/2 hours 22 hours	10 22
Flash point, °C, minimum	210
Rust Protection, maximum	Failure of one panel <u>5/</u>
Corrosivity, maximum	Failure of one disc <u>6/</u>
Corrosion: Change in weight, milligrams per square millimeter of surface, maximum: Each individual metal strip, except copper Copper strip Appearance of: Each metal strip tested Lubricating oil after test	0.002 0.004 No evidence of pitting or corrosion No soft sludge on the metal strip tested
Weight of sludge or other insolubles in oil tested, milligrams, maximum	0.2

TABLE II. Physical properties - Continued

Characteristics	Requirements
Resistance to oxidation (see <u>2/</u> ): Viscosity, m <sup>2</sup> /s, at 37.8°C percent, change, maximum Neutralization number, increase, maximum (see <u>2/</u> )	+ 15, -5  1.5
Thin film stability: Weight loss, percent, maximum Appearance of lubrication oil after test	75 Residue shall be a non-tacky liquid and not contain any visible lacquer or sludge.

- 1/ 5.0 ASTM Color (see Table III).
- 2/ Values are needed for comparison with that obtained after resistance to oxidation test.
- 3/ See 5.1.1.
- 4/ The lubricating oil shall not become cloudy or develop a haze.
- 5/ A panel shall be considered as having failed the protection test if, at the end of the test period, one of the following conditions exists in significant areas, as defined by ASTM D 1748, considering both sides of the panel:
  - a. A corroded area of 2-millimeters maximum dimension or larger.
  - b. Two or more spots between 1 and 2 millimeters maximum dimension.
- 6/ The discs shall be examined under 10X magnification for evidence of corrosion, pitting or other detrimental effects.

TABLE III. Quality conformance tests.

Inspection	Paragraph	
	Requirement	Test Method
Color	3.3	4.6.2
Neutralization number	3.3	4.6.2
Viscosity at 98.9°C, 37.8°C and -53.9°C	3.3	4.6.2
Pour point	3.3	4.6.2
Low temperature stability	3.3	4.6.2
Evaporation at 6-1/2 and 22 hours	3.3	4.6.2
Flash point	3.3	4.6.2
Rust Protection	3.3	4.6.3
Corrosivity	3.3	4.6.4
Corrosion and oxidation stability	3.3	4.6.5
Thin film stability	3.3	4.6.6
Particulate matter	3.3	4.6.7
Examination of filled container	5.1 through 5.3	4.6.1

DOD-L-81846B

TABLE IV. Test methods.

Tests	Method	
	FED-STD-791	ASTM
Color	-	D 1500
Neutralization number	-	D 974
Viscosity	-	D 445
Pour point	-	D 97
Low temperature stability	3458	-
Evaporation	-	D 972
Flash point	-	D 92

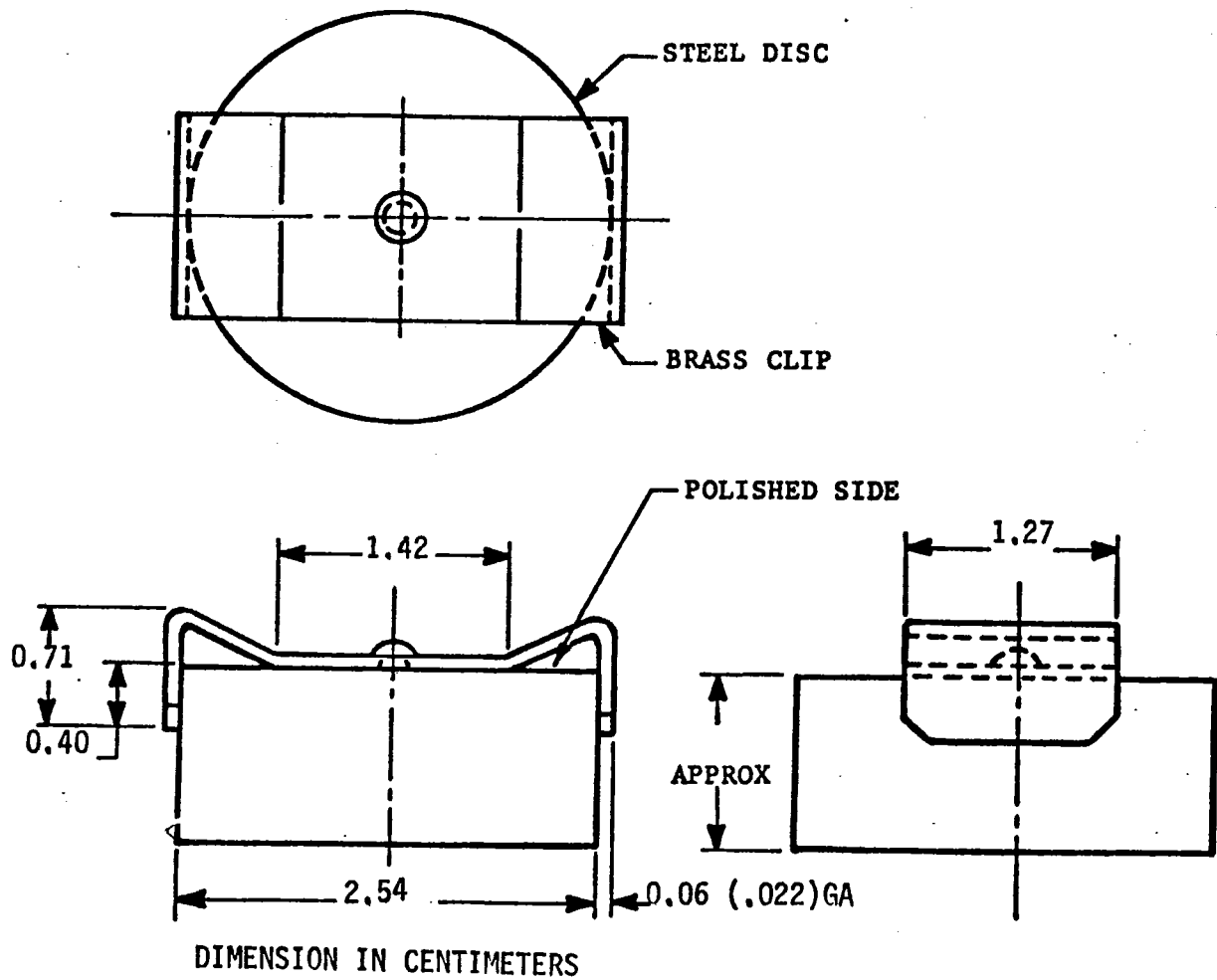

FIGURE 1. Typical test specimens for corrosivity test.



# STANDARDIZATION DOCUMENT IMPROVEMENT PROPOSAL

## INSTRUCTIONS

1. The preparing activity must complete blocks 1, 2, 3, and 8. In block 1, both the document number and revision letter should be given.
2. The submitter of this form must complete blocks 4, 5, 6, and 7, and send to preparing activity.
3. The preparing activity must provide a reply within 30 days from receipt of the form.

NOTE: This form may not be used to request copies of documents, nor to request waivers, or clarification of requirements on current contracts. Comments submitted on this form do not constitute or imply authorization to waive any portion of the referenced document(s) or to amend contractual requirements.

<b>I RECOMMEND A CHANGE:</b>		1. DOCUMENT NUMBER DOD-L-81846B	2. DOCUMENT DATE (YYYYMMDD) 3 September 1986
3. DOCUMENT TITLE LUBRICATING OIL, INSTRUMENT, BALL BEARING, HIGH FLASH POINT			
5. REASON FOR RECOMMENDATION			
6. SUBMITTER			
a. NAME (Last, First, Middle Initial)		b. ORGANIZATION	
c. ADDRESS (Include Zip Code)		d. TELEPHONE (Include Area Code) (1) Commercial (2) AUTOVON (if applicable)	7. DATE SUBMITTED (YYYYMMDD)
8. PREPARING ACTIVITY			
NAME		b. TELEPHONE (Include Area Code) (1) Commercial (2) AUTOVON	
c. ADDRESS (Include Zip Code)		<b>IF YOU DO NOT RECEIVE A REPLY WITHIN 45 DAYS, CONTACT:</b> Defense Standardization Program Office (DLSC-LM) 8725 John J. Kingman road, Suite 2533, Ft. Belvoir, VA 22060-2533 Telephone (703) 767-6888 AUTOVON 427-6888	