

DOE-HDBK-1014/2-92
JUNE 1992

DOE FUNDAMENTALS HANDBOOK

MATHEMATICS

Volume 2 of 2



U.S. Department of Energy
Washington, D.C. 20585

FSC-6910

Distribution Statement A. Approved for public release; distribution is unlimited.

This document has been reproduced directly from the best available copy.

Available to DOE and DOE contractors from the Office of Scientific and Technical Information. P. O. Box 62, Oak Ridge, TN 37831; (615) 576-8401.

Available to the public from the National Technical Information Service, U.S. Department of Commerce, 5285 Port Royal Rd., Springfield, VA 22161.

Order No. DE92019795

MATHEMATICS

ABSTRACT

The *Mathematics Fundamentals Handbook* was developed to assist nuclear facility operating contractors provide operators, maintenance personnel, and the technical staff with the necessary fundamentals training to ensure a basic understanding of mathematics and its application to facility operation. The handbook includes a review of introductory mathematics and the concepts and functional use of algebra, geometry, trigonometry, and calculus. Word problems, equations, calculations, and practical exercises that require the use of each of the mathematical concepts are also presented. This information will provide personnel with a foundation for understanding and performing basic mathematical calculations that are associated with various DOE nuclear facility operations.

Key Words: Training Material, Mathematics, Algebra, Geometry, Trigonometry, Calculus

FOREWORD

The *Department of Energy (DOE) Fundamentals Handbooks* consist of ten academic subjects, which include Mathematics; Classical Physics; Thermodynamics, Heat Transfer, and Fluid Flow; Instrumentation and Control; Electrical Science; Material Science; Mechanical Science; Chemistry; Engineering Symbology, Prints, and Drawings; and Nuclear Physics and Reactor Theory. The handbooks are provided as an aid to DOE nuclear facility contractors.

These handbooks were first published as Reactor Operator Fundamentals Manuals in 1985 for use by DOE category A reactors. The subject areas, subject matter content, and level of detail of the Reactor Operator Fundamentals Manuals were determined from several sources. DOE Category A reactor training managers determined which materials should be included, and served as a primary reference in the initial development phase. Training guidelines from the commercial nuclear power industry, results of job and task analyses, and independent input from contractors and operations-oriented personnel were all considered and included to some degree in developing the text material and learning objectives.

The *DOE Fundamentals Handbooks* represent the needs of various DOE nuclear facilities' fundamental training requirements. To increase their applicability to nonreactor nuclear facilities, the Reactor Operator Fundamentals Manual learning objectives were distributed to the Nuclear Facility Training Coordination Program Steering Committee for review and comment. To update their reactor-specific content, DOE Category A reactor training managers also reviewed and commented on the content. On the basis of feedback from these sources, information that applied to two or more DOE nuclear facilities was considered generic and was included. The final draft of each of the handbooks was then reviewed by these two groups. This approach has resulted in revised modular handbooks that contain sufficient detail such that each facility may adjust the content to fit their specific needs.

Each handbook contains an abstract, a foreword, an overview, learning objectives, and text material, and is divided into modules so that content and order may be modified by individual DOE contractors to suit their specific training needs. Each subject area is supported by a separate examination bank with an answer key.

The *DOE Fundamentals Handbooks* have been prepared for the Assistant Secretary for Nuclear Energy, Office of Nuclear Safety Policy and Standards, by the DOE Training Coordination Program. This program is managed by EG&G Idaho, Inc.

OVERVIEW

The *Department of Energy Fundamentals Handbook* entitled *Mathematics* was prepared as an information resource for personnel who are responsible for the operation of the Department's nuclear facilities. A basic understanding of mathematics is necessary for DOE nuclear facility operators, maintenance personnel, and the technical staff to safely operate and maintain the facility and facility support systems. The information in the handbook is presented to provide a foundation for applying engineering concepts to the job. This knowledge will help personnel more fully understand the impact that their actions may have on the safe and reliable operation of facility components and systems.

The *Mathematics* handbook consists of five modules that are contained in two volumes. The following is a brief description of the information presented in each module of the handbook.

Volume 1 of 2

Module 1 - Review of Introductory Mathematics

This module describes the concepts of addition, subtraction, multiplication, and division involving whole numbers, decimals, fractions, exponents, and radicals. A review of basic calculator operation is included.

Module 2 - Algebra

This module describes the concepts of algebra including quadratic equations and word problems.

Volume 2 of 2

Module 3 - Geometry

This module describes the basic geometric figures of triangles, quadrilaterals, and circles; and the calculation of area and volume.

Module 4 - Trigonometry

This module describes the trigonometric functions of sine, cosine, tangent, cotangent, secant, and cosecant. The use of the pythagorean theorem is also discussed.

MATHEMATICS

Module 5 - Higher Concepts of Mathematics

This module describes logarithmic functions, statistics, complex numbers, imaginary numbers, matrices, and integral and derivative calculus.

The information contained in this handbook is by no means all encompassing. An attempt to present the entire subject of mathematics would be impractical. However, the *Mathematics* handbook does present enough information to provide the reader with a fundamental knowledge level sufficient to understand the advanced theoretical concepts presented in other subject areas, and to better understand basic system and equipment operations.

**Department of Energy
Fundamentals Handbook**

**MATHEMATICS
Module 3
Geometry**

TABLE OF CONTENTS

| | |
|--|-----|
| LIST OF FIGURES | ii |
| LIST OF TABLES | iii |
| REFERENCES | iv |
| OBJECTIVES | v |
| BASIC CONCEPTS OF GEOMETRY | 1 |
| Terms | 1 |
| Lines | 1 |
| Important Facts | 2 |
| Angles | 2 |
| Summary | 5 |
| SHAPES AND FIGURES OF PLANE GEOMETRY | 6 |
| Triangles | 6 |
| Area and Perimeter of Triangles | 7 |
| Quadrilaterals | 8 |
| Circles | 11 |
| Summary | 12 |
| SOLID GEOMETRIC FIGURES | 13 |
| Rectangular Solids | 13 |
| Cube | 14 |
| Sphere | 14 |
| Right Circular Cone | 15 |
| Right Circular Cylinder | 16 |
| Summary | 17 |

LIST OF FIGURES

| | | |
|-----------|-----------------------------------|----|
| Figure 1 | Angle | 2 |
| Figure 2 | 360° Angle | 3 |
| Figure 3 | Right Angle | 3 |
| Figure 4 | Straight Angle | 3 |
| Figure 5 | Acute Angle | 4 |
| Figure 6 | Obtuse Angle | 4 |
| Figure 7 | Reflex Angle | 4 |
| Figure 8 | Types of Triangles | 7 |
| Figure 9 | Area of a Triangle | 7 |
| Figure 10 | Parallelogram | 8 |
| Figure 11 | Rectangle | 9 |
| Figure 12 | Square | 10 |
| Figure 13 | Circle | 11 |
| Figure 14 | Rectangular Solid | 13 |
| Figure 15 | Cube | 14 |
| Figure 16 | Sphere | 15 |
| Figure 17 | Right Circular Cone | 15 |
| Figure 18 | Right Circular Cylinder | 16 |

LIST OF TABLES

NONE

REFERENCES

- Dolciani, Mary P., et al., Algebra Structure and Method Book 1, Atlanta: Houghton-Mifflin, 1979.
- Naval Education and Training Command, Mathematics, Vol:1, NAVEDTRA 10069-D1, Washington, D.C.: Naval Education and Training Program Development Center, 1985.
- Olivio, C. Thomas and Olivio, Thomas P., Basic Mathematics Simplified, Albany, NY: Delmar, 1977.
- Science and Fundamental Engineering, Windsor, CT: Combustion Engineering, Inc., 1985.
- Academic Program For Nuclear Power Plant Personnel, Volume 1, Columbia, MD: General Physics Corporation, Library of Congress Card #A 326517, 1982.

TERMINAL OBJECTIVE

- 1.0 Given a calculator and the correct formula, **APPLY** the laws of geometry to solve mathematical problems.

ENABLING OBJECTIVES

- 1.1 **IDENTIFY** a given angle as either:
- Straight
 - Acute
 - Right
 - Obtuse
- 1.2 **STATE** the definitions of complimentary and supplementary angles.
- 1.3 **STATE** the definition of the following types of triangles:
- Equilateral
 - Isosceles
 - Acute
 - Obtuse
 - Scalene
- 1.4 Given the formula, **CALCULATE** the area and the perimeter of each of the following basic geometric shapes:
- Triangle
 - Parallelogram
 - Circle
- 1.5 Given the formula, **CALCULATE** the volume and surface areas of the following solid figures:
- Rectangular solid
 - Cube
 - Sphere
 - Right circular cone
 - Right circular cylinder

Intentionally Left Blank

BASIC CONCEPTS OF GEOMETRY

This chapter covers the basic language and terminology of plane geometry.

EO 1.1 IDENTIFY a given angle as either:

- a. **Straight**
- b. **Acute**
- c. **Right**
- d. **Obtuse**

EO 1.2 STATE the definitions of complimentary and supplementary angles.

Geometry is one of the oldest branches of mathematics. Applications of geometric constructions were made centuries before the mathematical principles on which the constructions were based were recorded. Geometry is a mathematical study of points, lines, planes, closed flat shapes, and solids. Using any one of these alone, or in combination with others, it is possible to describe, design, and construct every visible object.

The purpose of this section is to provide a foundation of geometric principles and constructions on which many practical problems depend for solution.

Terms

There are a number of terms used in geometry.

1. *A plane* is a flat surface.
2. *Space* is the set of all points.
3. *Surface* is the boundary of a solid.
4. *Solid* is a three-dimensional geometric figure.
5. *Plane geometry* is the geometry of planar figures (two dimensions). Examples are: angles, circles, triangles, and parallelograms.
6. *Solid geometry* is the geometry of three-dimensional figures. Examples are: cubes, cylinders, and spheres.

Lines

A *line* is the path formed by a moving point. A *length of a straight line* is the shortest distance between two nonadjacent points and is made up of collinear points. A *line segment* is a portion of a line. A *ray* is an infinite set of collinear points extending from one end point to infinity. A set of points is noncollinear if the points are not contained in a line.

Two or more straight lines are *parallel* when they are coplanar (contained in the same plane) and do not intersect; that is, when they are an equal distance apart at every point.

Important Facts

The following facts are used frequently in plane geometry. These facts will help you solve problems in this section.

1. The shortest distance between two points is the length of the straight line segment joining them.
2. A straight line segment can be extended indefinitely in both directions.
3. Only one straight line segment can be drawn between two points.
4. A geometric figure can be moved in the plane without any effect on its size or shape.
5. Two straight lines in the same plane are either parallel or they intersect.
6. Two lines parallel to a third line are parallel to each other.

Angles

An *angle* is the union of two nonparallel rays originating from the same point; this point is known as the vertex. The rays are known as sides of the angle, as shown in Figure 1.

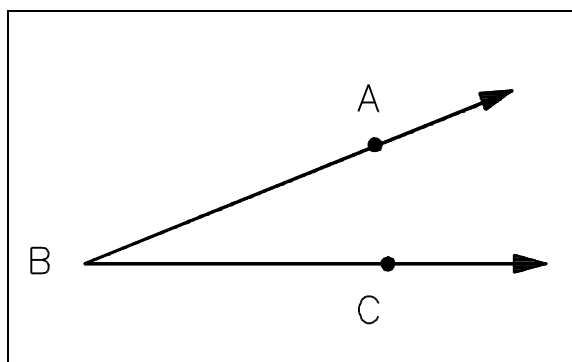

Figure 1 Angle

If ray AB is on top of ray BC , then the angle ABC is a *zero angle*. One complete revolution of a ray gives an angle of 360° .

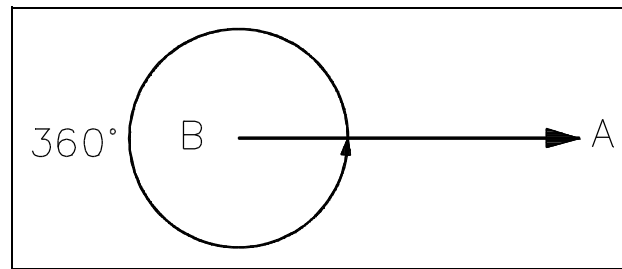

Figure 2 - 360° Angle

Depending on the rotation of a ray, an angle can be classified as right, straight, acute, obtuse, or reflex. These angles are defined as follows:

Right Angle - angle with a ray separated by 90°.

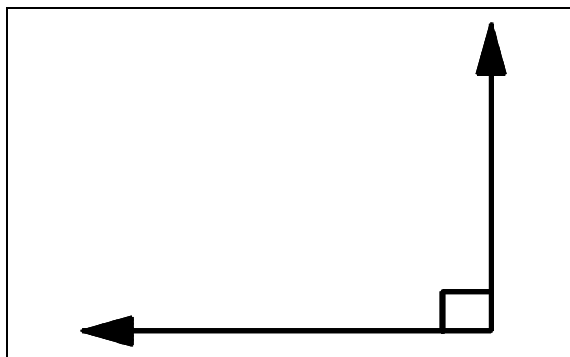

Figure 3 Right Angle

Straight Angle - angle with a ray separated by 180° to form a straight line.

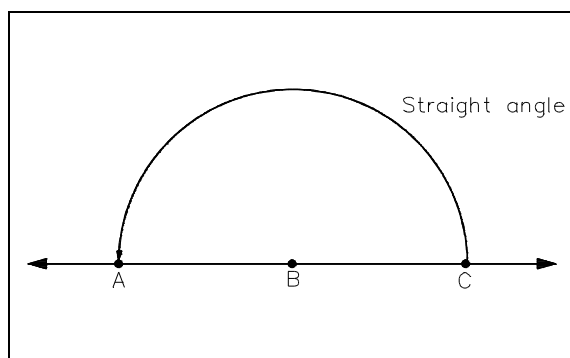

Figure 4 Straight Angle

Acute Angle - angle with a ray separated by less than 90° .

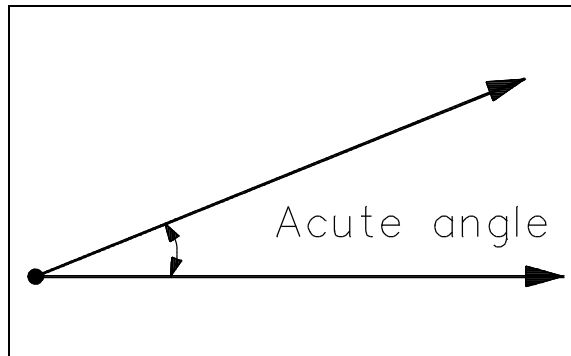

Figure 5 Acute Angle

Obtuse Angle - angle with a ray rotated greater than 90° but less than 180° .

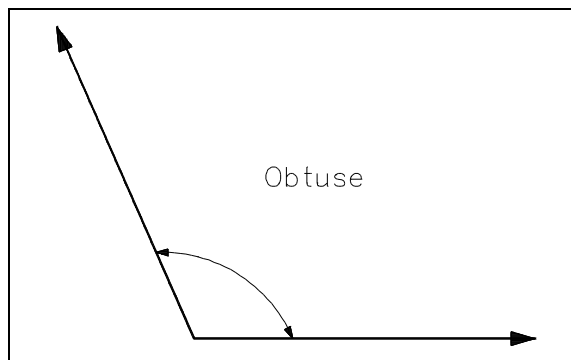

Figure 6 Obtuse Angle

Reflex Angle - angle with a ray rotated greater than 180° .

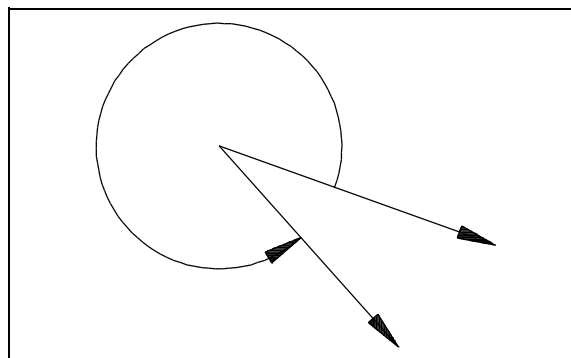

Figure 7 Reflex Angle

If angles are next to each other, they are called *adjacent angles*. If the sum of two angles equals 90° , they are called *complimentary angles*. For example, 27° and 63° are complimentary angles. If the sum of two angles equals 180° , they are called *supplementary angles*. For example, 73° and 107° are supplementary angles.

Summary

The important information in this chapter is summarized below.

Lines and Angles Summary

- Straight lines are parallel when they are in the same plane and do not intersect.
- A straight angle is 180° .
- An acute angle is less than 90° .
- A right angle is 90° .
- An obtuse angle is greater than 90° but less than 180° .
- If the sum of two angles equals 90° , they are complimentary angles.
- If the sum of two angles equals 180° , they are supplementary angles.

SHAPES AND FIGURES OF PLANE GEOMETRY

This chapter covers the calculation of the perimeter and area of selected plane figures.

EO 1.3 STATE the definition of the following types of triangles:

- a. **Equilateral**
- b. **Isosceles**
- c. **Acute**
- d. **Obtuse**
- e. **Scalene**

EO 1.4 Given the formula, CALCULATE the area and the perimeter of each of the following basic geometric shapes:

- a. **Triangle**
 - b. **Parallelogram**
 - c. **Circle**
-

The terms and properties of lines, angles, and circles may be applied in the layout, design, development, and construction of closed flat shapes. A new term, plane, must be understood in order to accurately visualize a closed, flat shape. A plane refers to a flat surface on which lies a straight line connecting any two points.

A plane figure is one which can be drawn on a plane surface. There are many types of plane figures encountered in practical problems. Fundamental to most design and construction are three flat shapes: the triangle, the rectangle, and the circle.

Triangles

A *triangle* is a figure formed by using straight line segments to connect three points that are not in a straight line. The straight line segments are called sides of the triangle.

Examples of a number of types of triangles are shown in Figure 8. An *equilateral triangle* is one in which all three sides and all three angles are equal. Triangle *ABC* in Figure 8 is an example of an equilateral triangle. An *isosceles triangle* has two equal sides and two equal angles (triangle *DEF*). A *right triangle* has one of its angles equal to 90° and is the most important triangle for our studies (triangle *GHI*). An *acute triangle* has each of its angles less than 90° (triangle *JKL*). Triangle *MNP* is called a *scalene triangle* because each side is a different length. Triangle *QRS* is considered an *obtuse triangle* since it has one angle greater than 90° . A triangle may have more than one of these attributes. The sum of the interior angles in a triangle is always 180° .

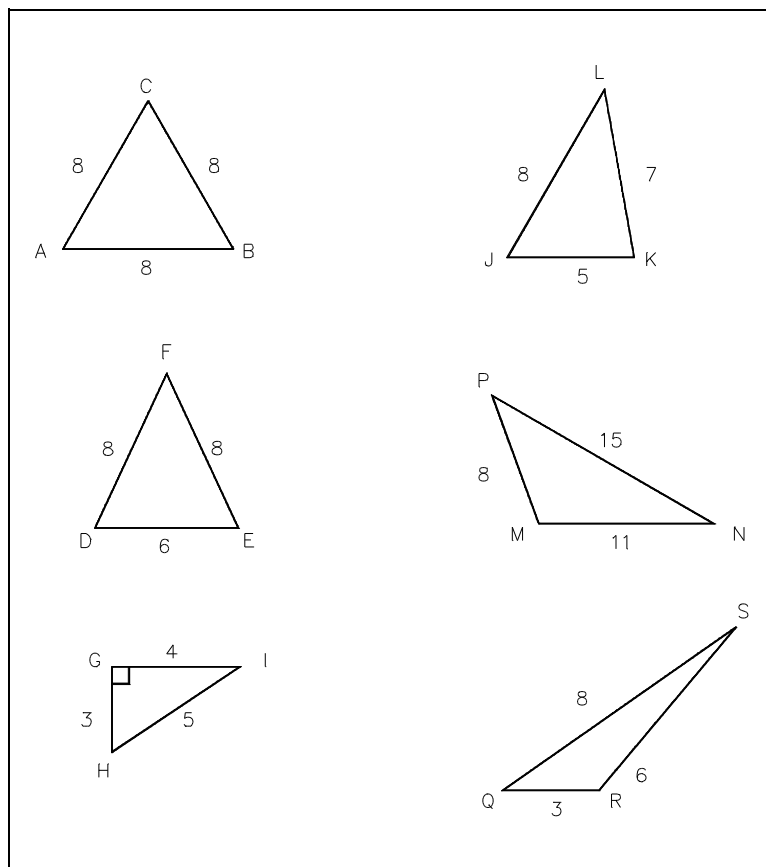

Figure 8 Types of Triangles

Area and Perimeter of Triangles

The area of a triangle is calculated using the formula:

$$A = (1/2)(\text{base}) \cdot (\text{height}) \quad (3-1)$$

or

$$A = (1/2)bh$$

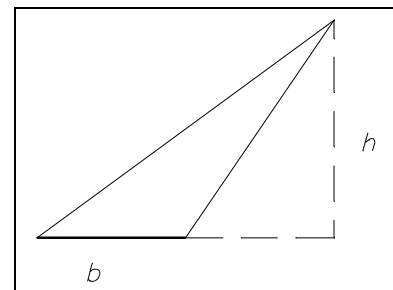

Figure 9 Area of a Triangle

The perimeter of a triangle is calculated using the formula:

$$P = side_1 + side_2 + side_3. \quad (3-2)$$

The area of a triangle is always expressed in square units, and the perimeter of a triangle is always expressed in the original units.

Example:

Calculate the area and perimeter of a right triangle with a 9" base and sides measuring 12" and 15". Be sure to include the units in your answer.

Solution:

$$A = 1/2 bh$$

$$A = .5(9)(12)$$

$$A = .5(108)$$

$$A = 54 \text{ square inches}$$

$$P = s_1 + s_2 + b$$

$$P = 9 + 12 + 15$$

$$P = 36 \text{ inches}$$

Quadrilaterals

A *quadrilateral* is any four-sided geometric figure.

A *parallelogram* is a four-sided quadrilateral with both pairs of opposite sides parallel, as shown in Figure 10.

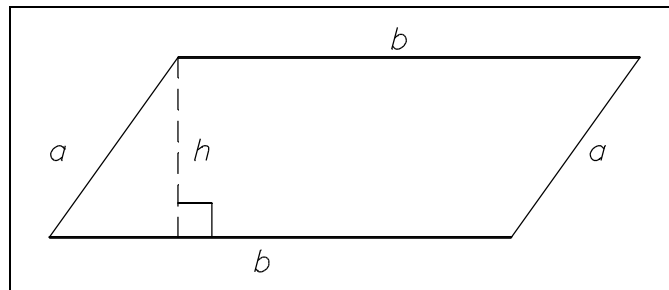

Figure 10 Parallelogram

The area of the parallelogram is calculated using the following formula:

$$A = (\text{base}) \cdot (\text{height}) = bh \quad (3-3)$$

The perimeter of a parallelogram is calculated using the following formula:

$$P = 2a + 2b \quad (3-4)$$

The area of a parallelogram is always expressed in square units, and the perimeter of a parallelogram is always expressed in the original units.

Example:

Calculate the area and perimeter of a parallelogram with base (b) = 4', height (h) = 3', $a = 5'$ and $b = 4'$. Be sure to include units in your answer.

Solution:

$$A = bh$$

$$A = (4)(3)$$

$$A = 12 \text{ square feet}$$

$$P = 2a + 2b$$

$$P = 2(5) + 2(4)$$

$$P = 10 + 8$$

$$P = 18 \text{ feet}$$

A *rectangle* is a parallelogram with four right angles, as shown in Figure 11.

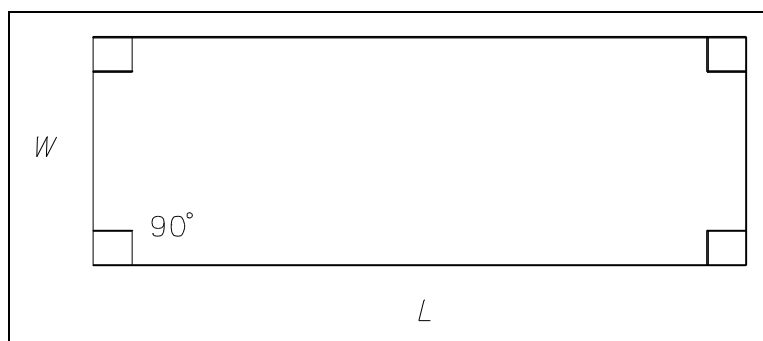

Figure 11 Rectangle

The area of a rectangle is calculated using the following formula:

$$A = (\text{length}) \cdot (\text{width}) = lw \quad (3-5)$$

The perimeter of a rectangle is calculated using the following formula:

$$P = 2(\text{length}) + 2(\text{width}) = 2l + 2w \quad (3-6)$$

The area of a rectangle is always expressed in square units, and the perimeter of a rectangle is always expressed in the original units.

Example:

Calculate the area and perimeter of a rectangle with $w = 5'$ and $l = 6'$. Be sure to include units in your answer.

Solution:

$$\begin{aligned} A &= lw \\ A &= (5)(6) \\ A &= 30 \text{ square feet} \end{aligned}$$

$$\begin{aligned} P &= 2l + 2w \\ P &= 2(5) + 2(6) \\ P &= 10 + 12 \\ P &= 22 \text{ feet} \end{aligned}$$

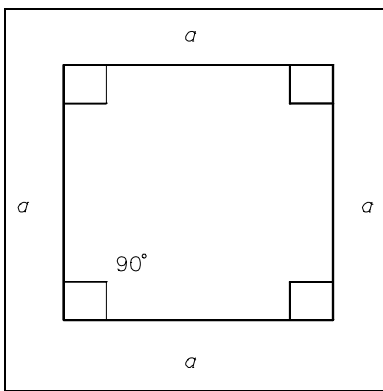

A *square* is a rectangle having four equal sides, as shown in Figure 12.

The area of a square is calculated using the following formula:

$$A = a^2 \quad (3-7)$$

The perimeter of a square is calculated using the following formula:

$$A = 4a \quad (3-8)$$

Figure 12 Square

The area of a square is always expressed in square units, and the perimeter of a square is always expressed in the original units.

Example:

Calculate the area and perimeter of a square with $a = 5'$. Be sure to include units in your answer.

Solution:

$$\begin{aligned} A &= a^2 \\ A &= (5)(5) \\ A &= 25 \text{ square feet} \end{aligned}$$

$$\begin{aligned} P &= 4a \\ P &= 4(5) \\ P &= 20 \text{ feet} \end{aligned}$$

Circles

A *circle* is a plane curve which is equidistant from the center, as shown in Figure 13. The length of the perimeter of a circle is called the *circumference*. The *radius* (r) of a circle is a line segment that joins the center of a circle with any point on its circumference. The *diameter* (D) of a circle is a line segment connecting two points of the circle through the center. The area of a circle is calculated using the following formula:

$$A = \pi r^2 \quad (3-9)$$

The circumference of a circle is calculated using the following formula:

$$C = 2\pi r \quad (3-10)$$

or

$$C = \pi D$$

Pi (π) is a theoretical number, approximately $22/7$ or 3.141592654 , representing the ratio of the circumference to the diameter of a circle. The scientific calculator makes this easy by designating a key for determining π .

The area of a circle is always expressed in square units, and the perimeter of a circle is always expressed in the original units.

Example:

Calculate the area and circumference of a circle with a 3" radius. Be sure to include units in your answer.

Solution:

$$A = \pi r^2$$

$$A = \pi(3)(3)$$

$$A = \pi(9)$$

$$A = 28.3 \text{ square inches}$$

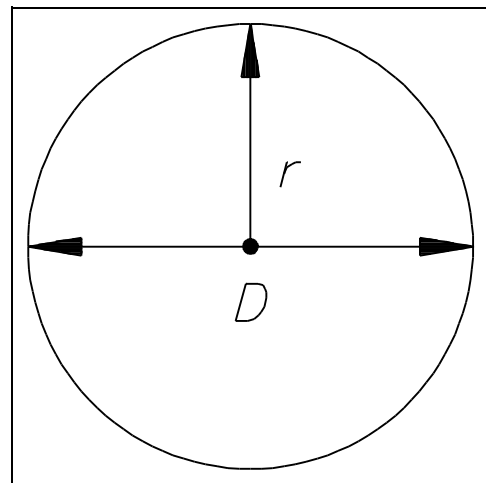

Figure 13 Circle

$$C = 2\pi r$$

$$C = (2)\pi(3)$$

$$C = \pi(6)$$

$$C = 18.9 \text{ inches}$$

Summary

The important information in this chapter is summarized below.

Shapes and Figures of Plane Geometry Summary

- Equilateral Triangle - all sides equal
- Isosceles Triangle - 2 equal sides and 2 equal angles
- Right Triangle - 1 angle equal to 90°
- Acute Triangle - each angle less than 90°
- Obtuse Triangle - 1 angle greater than 90°
- Scalene Triangle - each side a different length
- Area of a triangle - $A = (1/2)(base) \cdot (height)$
- Perimeter of a triangle - $P = side_1 + side_2 + side_3$
- Area of a parallelogram - $A = (base) \cdot (height)$
- Perimeter of a parallelogram - $P = 2a + 2b$ where a and b are length of sides
- Area of a rectangle - $A = (length) \cdot (width)$
- Perimeter of a rectangle - $P = 2(length) + 2(width)$
- Area of a square - $A = edge^2$
- Perimeter of a square - $P = 4 \times edge$
- Area of a circle - $A = \pi r^2$
- Circumference of a circle - $C = 2\pi r$

SOLID GEOMETRIC FIGURES

This chapter covers the calculation of the surface area and volume of selected solid figures.

EO 1.5 Given the formula, **CALCULATE** the volume and surface areas of the following solid figures:

- a. Rectangular solid
- b. Cube
- c. Sphere
- d. Right circular cone
- e. Right circular cylinder

The three flat shapes of the triangle, rectangle, and circle may become solids by adding the third dimension of depth. The triangle becomes a cone; the rectangle, a rectangular solid; and the circle, a cylinder.

Rectangular Solids

A *rectangular solid* is a six-sided solid figure with faces that are rectangles, as shown in Figure 14.

The volume of a rectangular solid is calculated using the following formula:

$$V = abc \quad (3-11)$$

The surface area of a rectangular solid is calculated using the following formula:

$$SA = 2(ab + ac + bc) \quad (3-12)$$

The surface area of a rectangular solid is expressed in square units, and the volume of a rectangular solid is expressed in cubic units.

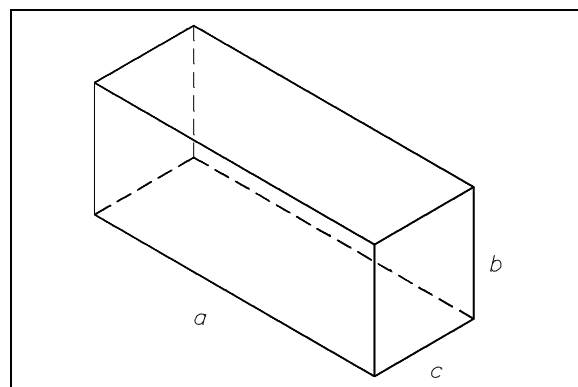

Figure 14 Rectangular Solid

Example:

Calculate the volume and surface area of a rectangular solid with $a = 3$ ", $b = 4$ ", and $c = 5$ ". Be sure to include units in your answer.

Solution:

$$\begin{array}{ll} V = (a)(b)(c) & SA = 2(ab + ac + bc) \\ V = (3)(4)(5) & SA = 2[(3)(4) + (3)(5) + (4)(5)] \\ V = (12)(5) & SA = 2[12 + 15 + 20] \\ V = 60 \text{ cubic inches} & SA = 2[47] \\ & SA = 94 \text{ square inches} \end{array}$$

Cube

A *cube* is a six-sided solid figure whose faces are congruent squares, as shown in Figure 15.

The volume of a cube is calculated using the following formula:

$$V = a^3 \quad (3-13)$$

The surface area of a cube is calculated using the following formula:

$$SA = 6a^2 \quad (3-14)$$

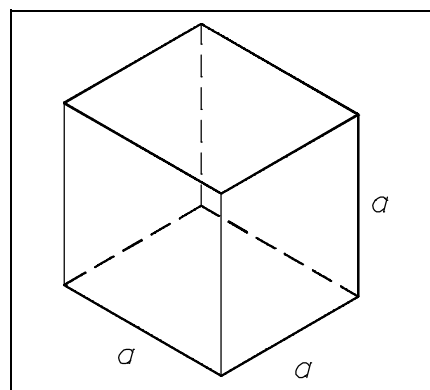

Figure 15 Cube

The surface area of a cube is expressed in square units, and the volume of a cube is expressed in cubic units.

Example:

Calculate the volume and surface area of a cube with $a = 3$ ". Be sure to include units in your answer.

Solution:

$$\begin{array}{ll} V = a^3 & SA = 6a^2 \\ V = (3)(3)(3) & SA = 6(3)(3) \\ V = 27 \text{ cubic inches} & SA = 6(9) \\ & SA = 54 \text{ square inches} \end{array}$$

Sphere

A *sphere* is a solid, all points of which are equidistant from a fixed point, the center, as shown in Figure 16.

The volume of a sphere is calculated using the following formula:

$$V = \frac{4}{3}\pi r^3 \quad (3-15)$$

The surface area of a sphere is calculated using the following formula:

$$SA = 4\pi r^2 \quad (3-16)$$

The surface area of a sphere is expressed in square units, and the volume of a sphere is expressed in cubic units.

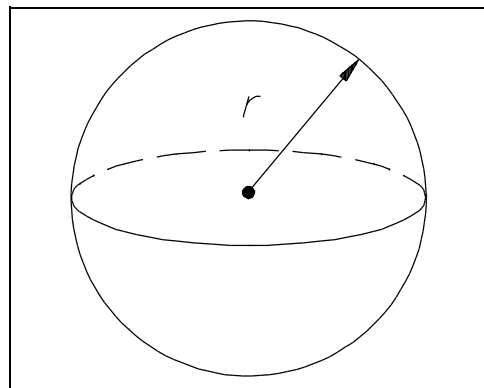

Figure 16 Sphere

Example:

Calculate the volume and surface area of a sphere with $r = 4$ ". Be sure to include units in your answer.

Solution:

$$\begin{aligned} V &= \frac{4}{3}\pi r^3 \\ V &= \frac{4}{3}\pi(4)(4)(4) \\ V &= 4.2(64) \\ V &= 268.8 \text{ cubic inches} \end{aligned}$$

$$\begin{aligned} SA &= 4\pi r^2 \\ SA &= 4\pi(4)(4) \\ SA &= 12.6(16) \\ SA &= 201.6 \text{ square inches} \end{aligned}$$

Right Circular Cone

A *right circular cone* is a cone whose axis is a line segment joining the vertex to the midpoint of the circular base, as shown in Figure 17.

The volume of a right circular cone is calculated using the following formula:

$$V = \frac{1}{3}\pi r^2 h \quad (3-17)$$

The surface area of a right circular cone is calculated using the following formula:

$$SA = \pi r^2 + \pi r l \quad (3-18)$$

The surface area of a right circular cone is expressed in square units, and the volume of a right circular cone is expressed in cubic units.

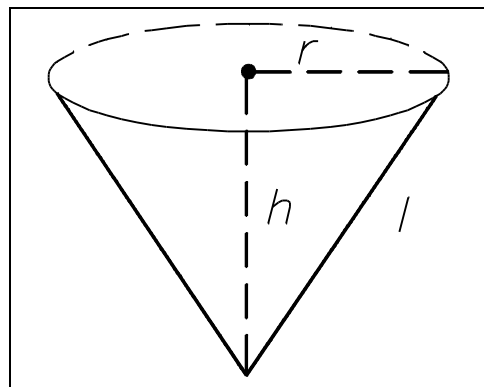

Figure 17 Right Circular Cone

Example:

Calculate the volume and surface area of a right circular cone with $r = 3''$, $h = 4''$, and $l = 5''$. Be sure to include the units in your answer.

Solution:

$$\begin{aligned} V &= 1/3\pi r^2 h \\ V &= 1/3\pi(3)(3)(4) \\ V &= 1.05(36) \\ V &= 37.8 \text{ cubic inches} \end{aligned}$$

$$\begin{aligned} SA &= \pi r^2 + \pi r l \\ SA &= \pi(3)(3) + \pi(3)(5) \\ SA &= \pi(9) + \pi(15) \\ SA &= 28.3 + 47.1 \\ SA &= 528/7 = 75\text{-}3/7 \text{ square inches} \end{aligned}$$

Right Circular Cylinder

A *right circular cylinder* is a cylinder whose base is perpendicular to its sides. Facility equipment, such as the reactor vessel, oil storage tanks, and water storage tanks, is often of this type.

The volume of a right circular cylinder is calculated using the following formula:

$$V = \pi r^2 h \quad (3-19)$$

The surface area of a right circular cylinder is calculated using the following formula:

$$SA = 2\pi r h + 2\pi r^2 \quad (3-20)$$

The surface area of a right circular cylinder is expressed in square units, and the volume of a right circular cylinder is expressed in cubic units.

Example:

Calculate the volume and surface area of a right circular cylinder with $r = 3''$ and $h = 4''$. Be sure to include units in your answer.

Solution:

$$\begin{aligned} V &= \pi r^2 h \\ V &= \pi(3)(3)(4) \\ V &= \pi(36) \\ V &= 113.1 \text{ cubic inches} \end{aligned}$$

$$\begin{aligned} SA &= 2\pi r h + 2\pi r^2 \\ SA &= 2\pi(3)(4) + 2\pi(3)(3) \\ SA &= 2\pi(12) + 2\pi(9) \\ SA &= 132 \text{ square inches} \end{aligned}$$

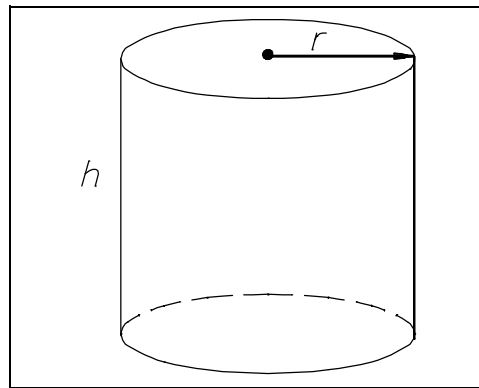

Figure 18 Right Circular Cylinder

Summary

The important information in this chapter is summarized below.

Solid Geometric Shapes Summary

- Volume of a rectangular solid: abc
Surface area of a rectangular solid: $2(ab + ac + bc)$
- Volume of a cube: a^3
- Surface area of a cube: $6a^2$
- Volume of a sphere: $4/3\pi r^3$
- Surface area of a sphere: $4\pi r^2$
- Volume of a right circular cone: $1/3\pi r^2 h$
- Surface area of a right circular cone: $\pi r^2 + \pi r l$
- Volume of a right circular cylinder: $\pi r^2 h$
- Surface area of right circular cylinder: $2\pi r h + 2\pi r^2$

Intentionally Left Blank

**Department of Energy
Fundamentals Handbook**

**MATHEMATICS
Module 4
Trigonometry**

TABLE OF CONTENTS

| | |
|---|-----|
| LIST OF FIGURES | ii |
| LIST OF TABLES | iii |
| REFERENCES | iv |
| OBJECTIVES | v |
| PYTHAGOREAN THEOREM | 1 |
| Pythagorean Theorem | 1 |
| Summary | 3 |
| TRIGONOMETRIC FUNCTIONS | 4 |
| Inverse Trigonometric Functions | 6 |
| Summary | 8 |
| RADIANS | 9 |
| Radian Measure | 9 |
| Summary | 10 |

LIST OF FIGURES

| | | |
|----------|---------------------------|---|
| Figure 1 | Triangle | 1 |
| Figure 2 | Right Triangle | 4 |
| Figure 3 | Example Problem | 5 |
| Figure 4 | Radian Angle | 9 |

LIST OF TABLES

NONE

REFERENCES

- Academic Program For Nuclear Power Plant Personnel, Volume 1, Columbia, MD: General Physics Corporation, Library of Congress Card #A 326517, 1982.
- Drooyan, I. and Wooton, W., Elementary Algebra and College Students, 6th Edition, John Wiley & Sons, 1984.
- Ellis, R. and Gulick, D., College Algebra and Trigonometry, 2nd Edition, Harcourt Brace Jouanovich, Publishers, 1984.
- Rice, B.J. and Strange, J.D., Plane Trigonometry, 2nd Edition, Prinole, Weber & Schmidt, Inc., 1978.

TERMINAL OBJECTIVE

- 1.0** Given a calculator and a list of formulas, **APPLY** the laws of trigonometry to solve for unknown values.

ENABLING OBJECTIVES

- 1.1** Given a problem, **APPLY** the Pythagorean theorem to solve for the unknown values of a right triangle.
- 1.2** Given the following trigonometric terms, **IDENTIFY** the related function:
- a. Sine
 - b. Cosine
 - c. Tangent
 - d. Cotangent
 - e. Secant
 - f. Cosecant
- 1.3** Given a problem, **APPLY** the trigonometric functions to solve for the unknown.
- 1.4** **STATE** the definition of a radian.

Intentionally Left Blank

PYTHAGOREAN THEOREM

This chapter covers right triangles and solving for unknowns using the Pythagorean theorem.

EO 1.1 **Given a problem, APPLY the Pythagorean theorem to solve for the unknown values of a right triangle.**

Trigonometry is the branch of mathematics that is the study of angles and the relationship between angles and the lines that form them. Trigonometry is used in Classical Physics and Electrical Science to analyze many physical phenomena. Engineers and operators use this branch of mathematics to solve problems encountered in the classroom and on the job. The most important application of trigonometry is the solution of problems involving triangles, particularly right triangles.

Trigonometry is one of the most useful branches of mathematics. It is used to indirectly measure distances which are difficult to measure directly. For example, the height of a flagpole or the distance across a river can be measured using trigonometry.

As shown in Figure 1 below, a triangle is a plane figure formed using straight line segments (AB , BC , CA) to connect three points (A , B , C) that are not in a straight line. The sum of the measures of the three interior angles (a' , b' , c') is 180° , and the sum of the lengths of any two sides is always greater than or equal to the third.

Pythagorean Theorem

The Pythagorean theorem is a tool that can be used to solve for unknown values on right triangles. In order to use the Pythagorean theorem, a term must be defined. The term *hypotenuse* is used to describe the side of a right triangle opposite the right angle. Line segment C is the hypotenuse of the triangle in Figure 1.

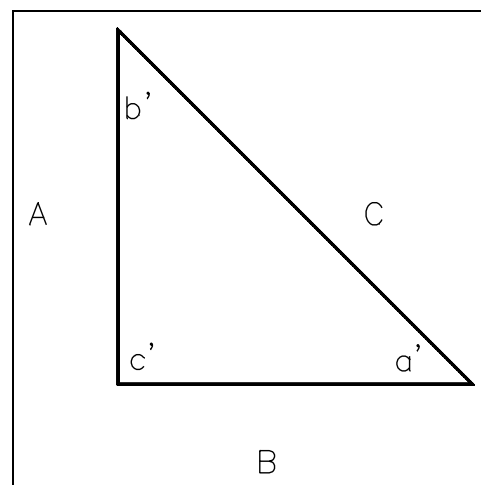

Figure 1 Triangle

The Pythagorean theorem states that in any right triangle, the square of the length of the hypotenuse equals the sum of the squares of the lengths of the other two sides.

This may be written as $c^2 = a^2 + b^2$ or $c = \sqrt{a^2 + b^2}$. (4-1)

Example:

The two legs of a right triangle are 5 ft and 12 ft. How long is the hypotenuse?

Let the hypotenuse be c ft.

$$a^2 + b^2 = c^2$$

$$12^2 + 5^2 = c^2$$

$$144 + 25 = c^2$$

$$169 = c^2$$

$$\sqrt{169} = c$$

$$13 \text{ ft} = c$$

Using the Pythagorean theorem, one can determine the value of the unknown side of a right triangle when given the value of the other two sides.

Example:

Given that the hypotenuse of a right triangle is 18" and the length of one side is 11", what is the length of the other side?

$$a^2 + b^2 = c^2$$

$$11^2 + b^2 = 18^2$$

$$b^2 = 18^2 - 11^2$$

$$b^2 = 324 - 121$$

$$b = \sqrt{203}$$

$$b = 14.2 \text{ in}$$

Summary

The important information in this chapter is summarized below.

Pythagorean Theorem Summary

- The Pythagorean theorem states that in any right triangle, the square of the length of the hypotenuse equals the sum of the squares of the lengths of the other two sides.

This may be written as $c^2 = a^2 + b^2$ or $c = \sqrt{a^2 + b^2}$.

TRIGONOMETRIC FUNCTIONS

This chapter covers the six trigonometric functions and solving right triangles.

EO 1.2 Given the following trigonometric terms, **IDENTIFY** the related function:

- a. Sine
- b. Cosine
- c. Tangent
- d. Cotangent
- e. Secant
- f. Cosecant

EO 1.3 Given a problem, **APPLY** the trigonometric functions to solve for the unknown.

As shown in the previous chapter, the lengths of the sides of right triangles can be solved using the Pythagorean theorem. We learned that if the lengths of two sides are known, the length of the third side can then be determined using the Pythagorean theorem. One fact about triangles is that the sum of the three angles equals 180° . If right triangles have one 90° angle, then the sum of the other two angles must equal 90° . Understanding this, we can solve for the unknown angles if we know the length of two sides of a right triangle. This can be done by using the six trigonometric functions.

In right triangles, the two sides (other than the hypotenuse) are referred to as the opposite and adjacent sides. In Figure 2, side a is the opposite side of the angle θ and side b is the adjacent side of the angle θ . The terms hypotenuse, opposite side, and adjacent side are used to distinguish the relationship between an acute angle of a right triangle and its sides. This relationship is given by the six trigonometric functions listed below:

$$\text{sine } \theta = \frac{a}{c} = \frac{\text{opposite}}{\text{hypotenuse}} \quad (4-2)$$

$$\text{cosine } \theta = \frac{b}{c} = \frac{\text{adjacent}}{\text{hypotenuse}} \quad (4-3)$$

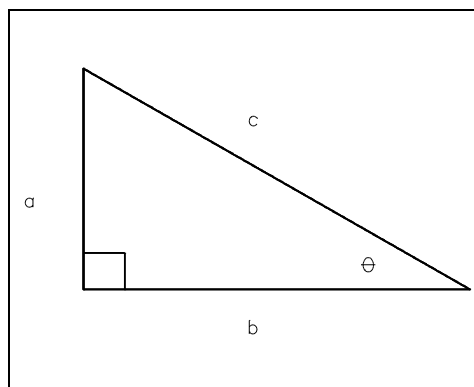

Figure 2 Right Triangle

$$\text{tangent } \theta = \frac{a}{b} = \frac{\text{opposite}}{\text{adjacent}} \quad (4-4)$$

$$\text{cosecant } \theta = \frac{c}{b} = \frac{\text{hypotenuse}}{\text{opposite}} \quad (4-5)$$

$$\text{secant } \theta = \frac{c}{a} = \frac{\text{hypotenuse}}{\text{adjacent}} \quad (4-6)$$

$$\text{cotangent } \theta = \frac{b}{a} = \frac{\text{adjacent}}{\text{opposite}} \quad (4-7)$$

The trigonometric value for any angle can be determined easily with the aid of a calculator. To find the sine, cosine, or tangent of any angle, enter the value of the angle into the calculator and press the desired function. Note that the secant, cosecant, and cotangent are the mathematical inverse of the sine, cosine and tangent, respectively. Therefore, to determine the cotangent, secant, or cosecant, first press the SIN, COS, or TAN key, then press the INV key.

Example:

Determine the values of the six trigonometric functions of an angle formed by the x-axis and a line connecting the origin and the point (3,4).

Solution:

To help to "see" the solution of the problem it helps to plot the points and construct the right triangle.

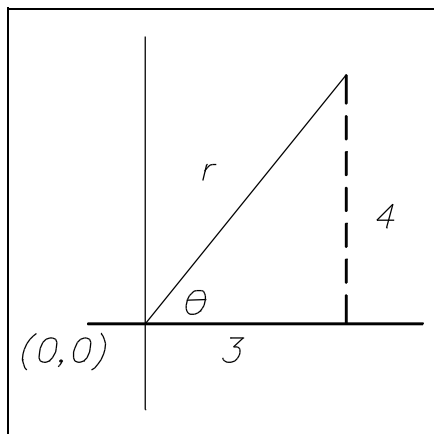

Figure 3 Example Problem

Label all the known angles and sides, as shown in Figure 3.

From the triangle, we can see that two of the sides are known. But to answer the problem, all three sides must be determined. Therefore the Pythagorean theorem must be applied to solve for the unknown side of the triangle.

$$x = 3$$

$$y = 4$$

$$r = \sqrt{x^2 + y^2} = \sqrt{3^2 + 4^2}$$

$$r = \sqrt{9 + 16} = \sqrt{25} = 5$$

Having solved for all three sides of the triangle, the trigonometric functions can now be determined. Substitute the values for x , y , and r into the trigonometric functions and solve.

$$\sin \theta = \frac{y}{r} = \frac{4}{5} = 0.800$$

$$\cos \theta = \frac{x}{r} = \frac{3}{5} = 0.600$$

$$\tan \theta = \frac{y}{x} = \frac{4}{3} = 1.333$$

$$\csc \theta = \frac{r}{y} = \frac{5}{4} = 1.250$$

$$\sec \theta = \frac{r}{x} = \frac{5}{3} = 1.667$$

$$\cot \theta = \frac{x}{y} = \frac{3}{4} = 0.750$$

Although the trigonometric functions of angles are defined in terms of lengths of the sides of right triangles, they are really functions of the angles only. The numerical values of the trigonometric functions of any angle depend on the size of the angle and not on the length of the sides of the angle. Thus, the sine of a 30° angle is always $1/2$ or 0.500 .

Inverse Trigonometric Functions

When the value of a trigonometric function of an angle is known, the size of the angle can be found. The inverse trigonometric function, also known as the arc function, defines the angle based on the value of the trigonometric function. For example, the sine of 21° equals 0.35837 ; thus, the arc sine of 0.35837 is 21° .

There are two notations commonly used to indicate an inverse trigonometric function.

$$\arcsin 0.35837 = 21^\circ$$

$$\sin^{-1} 0.35837 = 21^\circ$$

The notation *arcsin* means *the angle whose sine is*. The notation *arc* can be used as a prefix to any of the trigonometric functions. Similarly, the notation \sin^{-1} means *the angle whose sine is*. It is important to remember that the -1 in this notation is not a negative exponent but merely an indication of the inverse trigonometric function.

To perform this function on a calculator, enter the numerical value, press the INV key, then the SIN, COS, or TAN key. To calculate the inverse function of cot, csc, and sec, the reciprocal key must be pressed first then the SIN, COS, or TAN key.

Examples:

Evaluate the following inverse trigonometric functions.

$$\arcsin 0.3746 = 22^\circ$$

$$\arccos 0.3746 = 69^\circ$$

$$\arctan 0.3839 = 21^\circ$$

$$\operatorname{arccot} 2.1445 = \arctan \frac{1}{2.1445} = \arctan 0.4663 = 25^\circ$$

$$\operatorname{arcsec} 2.6695 = \arccos \frac{1}{2.6695} = \arccos 0.3746 = 68^\circ$$

$$\operatorname{arccsc} 2.7904 = \arcsin \frac{1}{2.7904} = \arcsin 0.3584 = 21^\circ$$

Summary

The important information in this chapter is summarized below.

Trigonometric Functions Summary

- The six trigonometric functions are:

$$\text{sine } \theta = \frac{a}{c} = \frac{\text{opposite}}{\text{hypotenuse}}$$

$$\text{cosine } \theta = \frac{b}{c} = \frac{\text{adjacent}}{\text{hypotenuse}}$$

$$\text{tangent } \theta = \frac{a}{b} = \frac{\text{opposite}}{\text{adjacent}}$$

$$\text{cotangent } \theta = \frac{b}{a} = \frac{\text{adjacent}}{\text{opposite}}$$

$$\text{cosecant } \theta = \frac{c}{b} = \frac{\text{hypotenuse}}{\text{opposite}}$$

$$\text{secant } \theta = \frac{c}{a} = \frac{\text{hypotenuse}}{\text{adjacent}}$$

RADIANS

This chapter will cover the measure of angles in terms of radians and degrees.

EO 1.4 STATE the definition of a radian.

Radian Measure

The size of an angle is usually measured in degrees. However, in some applications the size of an angle is measured in radians. A radian is defined in terms of the length of an arc subtended by an angle at the center of a circle. An angle whose size is one radian subtends an arc whose length equals the radius of the circle. Figure 4 shows $\angle BAC$ whose size is one radian. The length of arc BC equals the radius r of the circle. The size of an angle, in radians, equals the length of the arc it subtends divided by the radius.

$$\text{Radians} = \frac{\text{Length of Arc}}{\text{Radius}} \quad (4-8)$$

One radian equals approximately 57.3 degrees. There are exactly 2π radians in a complete revolution. Thus 2π radians equals 360 degrees: π radians equals 180 degrees.

Although the radian is defined in terms of the length of an arc, it can be used to measure any angle. Radian measure and degree measure can be converted directly. The size of an angle in degrees is changed to radians by multiplying by $\frac{\pi}{180}$. The size of an angle in radians is changed to degrees by multiplying by $\frac{180}{\pi}$.

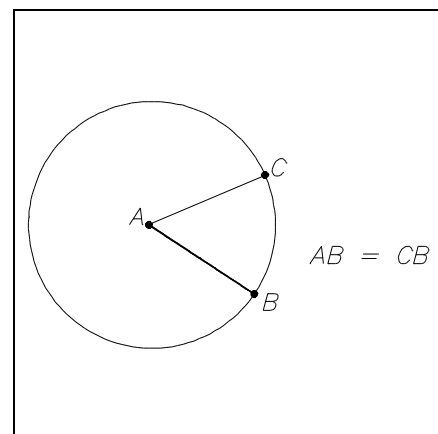

Figure 4 Radian Angle

Example:

Change 68.6° to radians.

$$68.6^\circ \left(\frac{\pi}{180} \right) = \frac{(68.6)\pi}{180} = 1.20 \text{ radians}$$

Example:

Change 1.508 radians to degrees.

$$(1.508 \text{ radians}) \left(\frac{180}{\pi} \right) = \frac{(1.508)(180)}{\pi} = 86.4^\circ$$

Summary

The important information in this chapter is summarized below.

Radian Measure Summary

- A radian equals approximately 57.3° and is defined as the angle subtended by an arc whose length is equal to the radius of the circle.

$$\text{Radian} = \frac{\text{Length of arc}}{\text{Radius of circle}}$$

$$\pi \text{ radians} = 180^\circ$$

**Department of Energy
Fundamentals Handbook**

**MATHEMATICS
Module 5
Higher Concepts of Mathematics**

TABLE OF CONTENTS

| | |
|---|-----|
| LIST OF FIGURES | iii |
| LIST OF TABLES | iv |
| REFERENCES | v |
| OBJECTIVES | vi |
| STATISTICS | 1 |
| Frequency Distribution | 1 |
| The Mean | 2 |
| Variability | 5 |
| Normal Distribution | 7 |
| Probability | 8 |
| Summary | 10 |
| IMAGINARY AND COMPLEX NUMBERS | 11 |
| Imaginary Numbers | 11 |
| Complex Numbers | 14 |
| Summary | 16 |
| MATRICES AND DETERMINANTS | 17 |
| The Matrix | 17 |
| Addition of Matrices | 18 |
| Multiplication of a Scaler and a Matrix | 19 |
| Multiplication of a Matrix by a Matrix | 20 |
| The Determinant | 21 |
| Using Matrices to Solve System of Linear Equation | 25 |
| Summary | 29 |

TABLE OF CONTENTS (Cont)

| | |
|--|----|
| CALCULUS | 30 |
| Dynamic Systems | 30 |
| Differentials and Derivatives | 30 |
| Graphical Understanding of Derivatives | 34 |
| Application of Derivatives to Physical Systems | 38 |
| Integral and Summations in Physical Systems | 41 |
| Graphical Understanding of Integral | 43 |
| Summary | 46 |

LIST OF FIGURES

| | | |
|----------|---|----|
| Figure 1 | Normal Probability Distribution | 7 |
| Figure 2 | Motion Between Two Points | 31 |
| Figure 3 | Graph of Distance vs. Time | 31 |
| Figure 4 | Graph of Distance vs. Time | 35 |
| Figure 5 | Graph of Distance vs. Time | 36 |
| Figure 6 | Slope of a Curve | 36 |
| Figure 7 | Graph of Velocity vs. Time | 41 |
| Figure 8 | Graph of Velocity vs. Time | 44 |

LIST OF TABLES

NONE

REFERENCES

- Dolciani, Mary P., et al., Algebra Structure and Method Book 1, Atlanta: Houghton-Mifflin, 1979.
- Naval Education and Training Command, Mathematics, Vol:3, NAVEDTRA 10073-A, Washington, D.C.: Naval Education and Training Program Development Center, 1969.
- Olivio, C. Thomas and Olivio, Thomas P., Basic Mathematics Simplified, Albany, NY: Delmar, 1977.
- Science and Fundamental Engineering, Windsor, CT: Combustion Engineering, Inc., 1985.
- Academic Program For Nuclear Power Plant Personnel, Volume 1, Columbia, MD: General Physics Corporation, Library of Congress Card #A 326517, 1982.
- Standard Mathematical Tables, 23rd Edition, Cleveland, OH: CRC Press, Inc., Library of Congress Card #30-4052, ISBN 0-87819-622-6, 1975.

TERMINAL OBJECTIVE

- 1.0 **SOLVE** problems involving probability and simple statistics.

ENABLING OBJECTIVES

- 1.1 **STATE** the definition of the following statistical terms:
- a. Mean
 - b. Variance
 - c. Mean variance
- 1.2 **CALCULATE** the mathematical mean of a given set of data.
- 1.3 **CALCULATE** the mathematical mean variance of a given set of data.
- 1.4 Given the data, **CALCULATE** the probability of an event.

TERMINAL OBJECTIVE

2.0 **SOLVE** for problems involving the use of complex numbers.

ENABLING OBJECTIVES

2.1 **STATE** the definition of an imaginary number.

2.2 **STATE** the definition of a complex number.

2.3 **APPLY** the arithmetic operations of addition, subtraction, multiplication, and division to complex numbers.

TERMINAL OBJECTIVE

3.0 **SOLVE** for the unknowns in a problem through the application of matrix mathematics.

ENABLING OBJECTIVES

3.1 **DETERMINE** the dimensions of a given matrix.

3.2 **SOLVE** a given set of equations using Cramer's Rule.

TERMINAL OBJECTIVE

4.0 **DESCRIBE** the use of differentials and integration in mathematical problems.

ENABLING OBJECTIVES

4.1 **STATE** the graphical definition of a derivative.

4.2 **STATE** the graphical definition of an integral.

Intentionally Left Blank

STATISTICS

This chapter will cover the basic concepts of statistics.

- EO 1.1** **STATE the definition of the following statistical terms:**
- a.** **Mean**
 - b.** **Variance**
 - c.** **Mean variance**
- EO 1.2** **CALCULATE the mathematical mean of a given set of data.**
- EO 1.3** **CALCULATE the mathematical mean variance of a given set of data.**
- EO 1.4** **Given the data, CALCULATE the probability of an event.**
-

In almost every aspect of an operator's work, there is a necessity for making decisions resulting in some significant action. Many of these decisions are made through past experience with other similar situations. One might say the operator has developed a method of intuitive inference: unconsciously exercising some principles of probability in conjunction with statistical inference following from observation, and arriving at decisions which have a high chance of resulting in expected outcomes. In other words, statistics is a method or technique which will enable us to approach a problem of determining a course of action in a systematic manner in order to reach the desired results.

Mathematically, statistics is the collection of great masses of numerical information that is summarized and then analyzed for the purpose of making decisions; that is, the use of past information is used to predict future actions. In this chapter, we will look at some of the basic concepts and principles of statistics.

Frequency Distribution

When groups of numbers are organized, or ordered by some method, and put into tabular or graphic form, the result will show the "frequency distribution" of the data.

Example:

A test was given and the following grades were received: the number of students receiving each grade is given in parentheses.

99(1), 98(2), 96(4), 92(7), 90(5), 88(13), 86(11), 83(7), 80(5), 78(4), 75(3), 60(1)

The data, as presented, is arranged in descending order and is referred to as an ordered array. But, as given, it is difficult to determine any trend or other information from the data. However, if the data is tabled and/or plotted some additional information may be obtained. When the data is ordered as shown, a frequency distribution can be seen that was not apparent in the previous list of grades.

| Grades | Number of Occurrences | Frequency Distribution |
|--------|-----------------------|------------------------|
| 99 | 1 | 1 |
| 98 | 11 | 2 |
| 96 | 1111 | 4 |
| 92 | 11111 11 | 7 |
| 90 | 11111 | 5 |
| 88 | 11111 11111 111 | 13 |
| 86 | 11111 11111 1 | 11 |
| 83 | 11111 11 | 7 |
| 80 | 11111 | 5 |
| 78 | 1111 | 4 |
| 75 | 111 | 3 |
| | 1 | 1 |

In summary, one method of obtaining additional information from a set of data is to determine the frequency distribution of the data. The frequency distribution of any one data point is the number of times that value occurs in a set of data. As will be shown later in this chapter, this will help simplify the calculation of other statistically useful numbers from a given set of data.

The Mean

One of the most common uses of statistics is the determination of the mean value of a set of measurements. The term "Mean" is the statistical word used to state the "average" value of a set of data. The mean is mathematically determined in the same way as the "average" of a group of numbers is determined.

The arithmetic mean of a set of N measurements, $X_1, X_2, X_3, \dots, X_N$ is equal to the sum of the measurements divided by the number of data points, N . Mathematically, this is expressed by the following equation:

$$\bar{x} = \frac{1}{n} \sum_{i=1}^n x_i$$

where

| | | |
|-----------|---|---|
| \bar{x} | = | the mean |
| n | = | the number of values (data) |
| x_1 | = | the first data point, x_2 = the second data point, ..., x_i = the i^{th} data point |
| x_i | = | the i^{th} data point, x_1 = the first data point, x_2 = the second data point, etc. |

The symbol Sigma (Σ) is used to indicate summation, and $i = 1$ to n indicates that the values of x_i from $i = 1$ to $i = n$ are added. The sum is then divided by the number of terms added, n .

Example:

Determine the mean of the following numbers:

5, 7, 1, 3, 4

Solution:

$$\bar{x} = \frac{1}{n} \sum_{i=1}^n x_i = \frac{1}{5} \sum_{i=1}^5 x_i$$

where

| | | |
|-----------|---|--|
| \bar{x} | = | the mean |
| n | = | the number of values (data) = 5 |
| x_1 | = | 5, $x_2 = 7$, $x_3 = 1$, $x_4 = 3$, $x_5 = 4$ |

substituting

$$\bar{x} = (5 + 7 + 1 + 3 + 4)/5 = 20/5 = 4$$

4 is the mean.

Example:

Find the mean of 67, 88, 91, 83, 79, 81, 69, and 74.

Solution:

$$\bar{x} = \frac{1}{n} \sum_{i=1}^n x_i$$

The sum of the scores is 632 and $n = 8$, therefore

$$\bar{x} = \frac{632}{8}$$

$$\bar{x} = 79$$

In many cases involving statistical analysis, literally hundreds or thousands of data points are involved. In such large groups of data, the frequency distribution can be plotted and the calculation of the mean can be simplified by multiplying each data point by its frequency distribution, rather than by summing each value. This is especially true when the number of discrete values is small, but the number of data points is large.

Therefore, in cases where there is a recurring number of data points, like taking the mean of a set of temperature readings, it is easier to multiply each reading by its frequency of occurrence (frequency of distribution), then adding each of the multiple terms to find the mean. This is one application using the frequency distribution values of a given set of data.

Example:

Given the following temperature readings,

573, 573, 574, 574, 574, 574, 575, 575, 575, 575, 575, 576, 576, 576, 578

Solution:

Determine the frequency of each reading.

| Frequency Distribution | | |
|------------------------|---------------|----------------------|
| Temperatures | Frequency (f) | (f)(x _i) |
| 573 | 2 | 1146 |
| 574 | 4 | 2296 |
| 575 | 5 | 2875 |
| 576 | 3 | 1728 |
| 578 | <u>1</u> | <u>578</u> |
| | 15 | 8623 |

Then calculate the mean,

$$\bar{x} = \frac{1}{n} \sum_{i=1}^n x_i$$

$$\bar{x} = \frac{2(573) + 4(574) + 5(575) + 3(576) + 1(578)}{15}$$

$$\bar{x} = \frac{8623}{15}$$

$$\bar{x} = 574.9$$

Variability

We have discussed the averages and the means of sets of values. While the mean is a useful tool in describing a characteristic of a set of numbers, sometimes it is valuable to obtain information about the mean. There is a second number that indicates how representative the mean is of the data. For example, in the group of numbers, 100, 5, 20, 2, the mean is 31.75. If these data points represent tank levels for four days, the use of the mean level, 31.75, to make a decision using tank usage could be misleading because none of the data points was close to the mean.

This spread, or distance, of each data point from the mean is called the *variance*. The variance of each data point is calculated by:

$$\text{Variance} = \bar{x} - x_i$$

where

$$x_i = \text{each data point}$$

$$\bar{x} = \text{mean}$$

The variance of each data point does not provide us with any useful information. But if the mean of the variances is calculated, a very useful number is determined. The *mean variance* is the average value of the variances of a set of data. The mean variance is calculated as follows:

$$\text{Mean Variance} = \frac{1}{n} \sum_{i=1}^n |x_i - \bar{x}|$$

The mean variance, or mean deviation, can be calculated and used to make judgments by providing information on the quality of the data. For example, if you were trying to decide whether to buy stock, and all you knew was that this month's average price was \$10, and today's price is \$9, you might be tempted to buy some. But, if you also knew that the mean variance in the stock's price over the month was \$6, you would realize the stock had fluctuated widely during the month. Therefore, the stock represented a more risky purchase than just the average price indicated.

It can be seen that to make sound decisions using statistical data, it is important to analyze the data thoroughly before making any decisions.

Example:

Calculate the variance and mean variance of the following set of hourly tank levels. Assume the tank is a 100 gal. tank. Based on the mean and the mean variance, would you expect the tank to be able to accept a 40% (40 gal.) increase in level at any time?

| | | |
|------------|------------|------------|
| 1:00 - 40% | 6:00 - 38% | 11:00- 34% |
| 2:00 - 38% | 7:00 - 34% | 12:00- 30% |
| 3:00 - 28% | 8:00 - 28% | 1:00 - 40% |
| 4:00 - 28% | 9:00 - 40% | 2:00 - 36% |
| 5:00 - 40% | 10:00- 38% | |

Solution:

The mean is

$$[40(4)+38(3)+36+34(2)+30+28(3)]/14= 492/14 = 35.1$$

The mean variance is:

$$\frac{1}{14} (|40 - 35.1| + |38 - 35.1| + |28 - 35.1| + \dots |36 - 35.1|) =$$

$$\frac{1}{14} (57.8) = 4.12$$

From the tank mean of 35.1%, it can be seen that a 40% increase in level will statistically fit into the tank; $35.1 + 40 < 100\%$. But, the mean doesn't tell us if the level varies significantly over time. Knowing the mean variance is 4.12% provides the additional information. Knowing the mean variance also allows us to infer that the level at any given time (most likely) will not be greater than $35.1 + 4.12 = 39.1\%$; and $39.1 + 40$ is still less than 100%. Therefore, it is a good assumption that, in the near future, a 40% level increase will be accepted by the tank without any spillage.

Normal Distribution

The concept of a normal distribution curve is used frequently in statistics. In essence, a normal distribution curve results when a large number of random variables are observed in nature, and their values are plotted. While this "distribution" of values may take a variety of shapes, it is interesting to note that a very large number of occurrences observed in nature possess a frequency distribution which is approximately bell-shaped, or in the form of a normal distribution, as indicated in Figure 1.

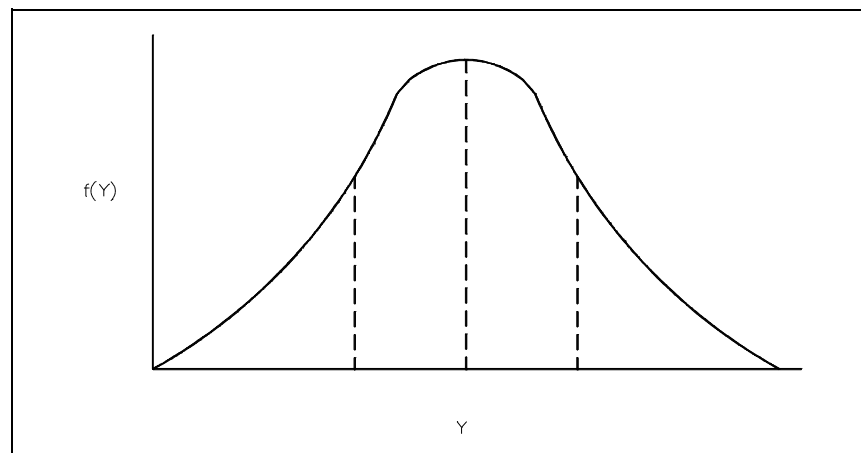

Figure 1 Graph of a Normal Probability Distribution

The significance of a normal distribution existing in a series of measurements is two fold. First, it explains why such measurements tend to possess a normal distribution; and second, it provides a valid basis for statistical inference. Many estimators and decision makers that are used to make inferences about large numbers of data, are really sums or averages of those measurements. When these measurements are taken, especially if a large number of them exist, confidence can be gained in the values, if these values form a bell-shaped curve when plotted on a distribution basis.

Probability

If E_1 is the number of heads, and E_2 is the number of tails, $E_1/(E_1 + E_2)$ is an experimental determination of the probability of heads resulting when a coin is flipped.

$$P(E_1) = n/N$$

By definition, the probability of an event must be greater than or equal to 0, and less than or equal to 1. In addition, the sum of the probabilities of all outcomes over the entire "event" must add to equal 1. For example, the probability of heads in a flip of a coin is 50%, the probability of tails is 50%. If we assume these are the only two possible outcomes, 50% + 50%, the two outcomes, equals 100%, or 1.

The concept of probability is used in statistics when considering the reliability of the data or the measuring device, or in the correctness of a decision. To have confidence in the values measured or decisions made, one must have an assurance that the probability is high of the measurement being true, or the decision being correct.

To calculate the probability of an event, the number of successes (s), and failures (f), must be determined. Once this is determined, the probability of the success can be calculated by:

$$P = \frac{s}{s + f}$$

where

$$s + f = n = \text{number of tries.}$$

Example:

Using a die, what is the probability of rolling a three on the first try?

Solution:

First, determine the number of possible outcomes. In this case, there are 6 possible outcomes. From the stated problem, the roll is a success only if a 3 is rolled. There is only 1 success outcome and 5 failures. Therefore,

$$\begin{aligned}\text{Probability} &= 1/(1+5) \\ &= 1/6\end{aligned}$$

In calculating probability, the probability of a series of independent events equals the product of probability of the individual events.

Example:

Using a die, what is the probability of rolling two 3s in a row?

Solution:

From the previous example, there is a 1/6 chance of rolling a three on a single throw. Therefore, the chance of rolling two threes is:

$$1/6 \times 1/6 = 1/36$$

one in 36 tries.

Example:

An elementary game is played by rolling a die and drawing a ball from a bag containing 3 white and 7 black balls. The player wins whenever he rolls a number less than 4 and draws a black ball. What is the probability of winning in the first attempt?

Solution:

There are 3 successful outcomes for rolling less than a 4, (i.e. 1,2,3). The probability of rolling a 3 or less is:

$$3/(3+3) = 3/6 = 1/2 \text{ or } 50\%.$$

The probability of drawing a black ball is:

$$7/(7+3) = 7/10.$$

Therefore, the probability of both events happening at the same time is:

$$7/10 \times 1/2 = 7/20.$$

Summary

The important information in this chapter is summarized below.

Statistics Summary

- | | | |
|------------------------|---|---|
| Mean | - | The sum of a group of values divided by the number of values. |
| Frequency Distribution | - | An arrangement of statistical data that exhibits the frequency of the occurrence of the values of a variable. |
| Variance | - | The difference of a data point from the mean. |
| Mean Variance | - | The mean or average of the absolute values of each data point's variance. |
| Probability of Success | - | The chances of being successful out of a number of tries. |

$$P = \frac{s}{s+f}$$

IMAGINARY AND COMPLEX NUMBERS

This chapter will cover the definitions and rules for the application of imaginary and complex numbers.

- EO 2.1** **STATE** the definition of an imaginary number.
- EO 2.2** **STATE** the definition of a complex number.
- EO 2.3** **APPLY** the arithmetic operations of addition, subtraction, and multiplication, and division to complex numbers.
-

Imaginary and complex numbers are entirely different from any kind of number used up to this point. These numbers are generated when solving some quadratic and higher degree equations. Imaginary and complex numbers become important in the study of electricity; especially in the study of alternating current circuits.

Imaginary Numbers

Imaginary numbers result when a mathematical operation yields the square root of a negative number. For example, in solving the quadratic equation $x^2 + 25 = 0$, the solution yields $x^2 = -25$. Thus, the roots of the equation are $x = \pm\sqrt{-25}$. The square root of (-25) is called an imaginary number. Actually, any even root (i.e. square root, 4th root, 6th root, etc.) of a negative number is called an imaginary number. All other numbers are called real numbers. The name "imaginary" may be somewhat misleading since imaginary numbers actually exist and can be used in mathematical operations. They can be added, subtracted, multiplied, and divided.

Imaginary numbers are written in a form different from real numbers. Since they are radicals, they can be simplified by factoring. Thus, the imaginary number $\sqrt{-25}$ equals $\sqrt{(25)(-1)}$, which equals $5\sqrt{-1}$. Similarly, $\sqrt{-9}$ equals $\sqrt{(9)(-1)}$, which equals $3\sqrt{-1}$. All imaginary numbers can be simplified in this way. They can be written as the product of a real number and $\sqrt{-1}$. In order to further simplify writing imaginary numbers, the imaginary unit i is defined as $\sqrt{-1}$. Thus, the imaginary number, $\sqrt{-25}$, which equals $5\sqrt{-1}$, is written as $5i$, and the imaginary number, $\sqrt{-9}$, which equals $3\sqrt{-1}$, is written $3i$. In using imaginary numbers in electricity, the imaginary unit is often represented by j , instead of i , since i is the common notation for electrical current.

Imaginary numbers are added or subtracted by writing them using the imaginary unit i and then adding or subtracting the real number coefficients of i . They are added or subtracted like algebraic terms in which the imaginary unit i is treated like a literal number. Thus, $\sqrt{-25}$ and $\sqrt{-9}$ are added by writing them as $5i$ and $3i$ and adding them like algebraic terms. The result is $8i$ which equals $8\sqrt{-1}$ or $\sqrt{-64}$. Similarly, $\sqrt{-9}$ subtracted from $\sqrt{-25}$ equals $3i$ subtracted from $5i$ which equals $2i$ or $2\sqrt{-1}$ or $\sqrt{-4}$.

Example:

Combine the following imaginary numbers:

Solution:

$$\begin{aligned}\sqrt{-16} + \sqrt{-36} - \sqrt{-49} - \sqrt{-1} &= \\ \sqrt{-16} + \sqrt{-36} - \sqrt{-49} - \sqrt{-1} &= 4i + 6i - 7i - i \\ &= 10i - 8i \\ &= 2i\end{aligned}$$

Thus, the result is $2i = 2\sqrt{-1} = \sqrt{-4}$

Imaginary numbers are multiplied or divided by writing them using the imaginary unit i , and then multiplying or dividing them like algebraic terms. However, there are several basic relationships which must also be used to multiply or divide imaginary numbers.

$$\begin{aligned}i^2 &= (i)(i) = (\sqrt{-1})(\sqrt{-1}) = -1 \\ i^3 &= (i^2)(i) = (-1)(i) = -i \\ i^4 &= (i^2)(i^2) = (-1)(-1) = +1\end{aligned}$$

Using these basic relationships, for example, $(\sqrt{-25})(\sqrt{-4})$ equals $(5i)(2i)$ which equals $10i^2$. But, i^2 equals -1 . Thus, $10i^2$ equals $(10)(-1)$ which equals -10 .

Any square root has two roots, i.e., a statement $x^2 = 25$ is a quadratic and has roots

$$x = \pm 5 \text{ since } +5^2 = 25 \text{ and } (-5) \times (-5) = 25.$$

Similarly,

$$\begin{aligned}\sqrt{-25} &= \pm 5i \\ \sqrt{-4} &= \pm 2i \\ \text{and} \\ \sqrt{-25} \sqrt{-4} &= \pm 10.\end{aligned}$$

Example 1:

Multiply $\sqrt{-2}$ and $\sqrt{-32}$.

Solution:

$$\begin{aligned}(\sqrt{-2})(\sqrt{-32}) &= (\sqrt{2}i)(\sqrt{32}i) \\ &= \sqrt{(2)(32)}i^2 \\ &= \sqrt{64}(-1) \\ &= 8(-1) \\ &= -8\end{aligned}$$

Example 2:

Divide $\sqrt{-48}$ by $\sqrt{-3}$.

Solution:

$$\begin{aligned}\frac{\sqrt{-48}}{\sqrt{-3}} &= \frac{\sqrt{48}i}{\sqrt{3}i} \\ &= \sqrt{\frac{48}{3}} \\ &= \sqrt{16} \\ &= 4\end{aligned}$$

Complex Numbers

Complex numbers are numbers which consist of a real part and an imaginary part. The solution of some quadratic and higher degree equations results in complex numbers. For example, the roots of the quadratic equation, $x^2 - 4x + 13 = 0$, are complex numbers. Using the quadratic formula yields two complex numbers as roots.

$$x = \frac{-b \pm \sqrt{b^2 - 4ac}}{2a}$$

$$x = \frac{4 \pm \sqrt{16 - 52}}{2}$$

$$x = \frac{4 \pm \sqrt{-36}}{2}$$

$$x = \frac{4 \pm 6i}{2}$$

$$x = 2 \pm 3i$$

The two roots are $2 + 3i$ and $2 - 3i$; they are both complex numbers. 2 is the real part; $+3i$ and $-3i$ are the imaginary parts. The general form of a complex number is $a + bi$, in which "a" represents the real part and "bi" represents the imaginary part.

Complex numbers are added, subtracted, multiplied, and divided like algebraic binomials. Thus, the sum of the two complex numbers, $7 + 5i$ and $2 + 3i$ is $9 + 8i$, and $7 + 5i$ minus $2 + 3i$, is $5 + 2i$. Similarly, the product of $7 + 5i$ and $2 + 3i$ is $14 + 31i + 15i^2$. But i^2 equals -1 . Thus, the product is $14 + 31i + 15(-1)$ which equals $-1 + 31i$.

Example 1:

Combine the following complex numbers:

$$(4 + 3i) + (8 - 2i) - (7 + 3i) =$$

Solution:

$$\begin{aligned} (4 + 3i) + (8 - 2i) - (7 + 3i) &= (4 + 8 - 7) + (3 - 2 - 3)i \\ &= 5 - 2i \end{aligned}$$

Example 2:

Multiply the following complex numbers:

$$(3 + 5i)(6 - 2i) =$$

Solution:

$$\begin{aligned} (3 + 5i)(6 - 2i) &= 18 + 30i - 6i - 10i^2 \\ &= 18 + 24i - 10(-1) \\ &= 28 + 24i \end{aligned}$$

Example 3:

Divide $(6+8i)$ by 2.

Solution:

$$\begin{aligned} \frac{6 + 8i}{2} &= \frac{6}{2} + \frac{8i}{2} \\ &= 3 + 4i \end{aligned}$$

A difficulty occurs when dividing one complex number by another complex number. To get around this difficulty, one must eliminate the imaginary portion of the complex number from the denominator, when the division is written as a fraction. This is accomplished by multiplying the numerator and denominator by the *conjugate* form of the denominator. The *conjugate* of a complex number is that complex number written with the opposite sign for the imaginary part. For example, the conjugate of $4+5i$ is $4-5i$.

This method is best demonstrated by example.

Example: $(4 + 8i) \div (2 - 4i)$

Solution:

$$\begin{aligned} \frac{4 + 8i}{2 - 4i} \cdot \frac{2 + 4i}{2 + 4i} &= \frac{8 + 32i + 32i^2}{4 - 16i^2} \\ &= \frac{8 + 32i + 32(-1)}{4 - 16(-1)} \\ &= \frac{-24 + 32i}{20} \\ &= -\frac{6}{5} + \frac{8i}{5} \end{aligned}$$

Summary

The important information from this chapter is summarized below.

Imaginary and Complex Numbers Summary

Imaginary Number

- An Imaginary number is the square root of a negative number.

Complex Number

- A complex number is any number that contains both a real and imaginary term.

Addition and Subtraction of Complex Numbers

- Add/subtract the real terms together, and add/subtract the imaginary terms of each complex number together. The result will be a complex number.

Multiplication of Complex Numbers

- Treat each complex number as an algebraic term and multiply/divide using rules of algebra. The result will be a complex number.

Division of Complex Numbers

- Put division in fraction form and multiply numerator and denominator by the conjugate of the denominator.

Rules of the Imaginary Number i

- $i^2 = (i)(i) = -1$
 $i^3 = (i^2)(i) = (-1)(i) = -i$
 $i^4 = (i^2)(i^2) = (-1)(-1) = +1$

MATRICES AND DETERMINANTS

This chapter will explain the idea of matrices and determinate and the rules needed to apply matrices in the solution of simultaneous equations.

EO 3.1 DETERMINE the dimensions of a given matrix.

EO 3.2 SOLVE a given set of equations using Cramer's Rule.

In the real world, many times the solution to a problem containing a large number of variables is required. In both physics and electrical circuit theory, many problems will be encountered which contain multiple simultaneous equations with multiple unknowns. These equations can be solved using the standard approach of eliminating the variables or by one of the other methods. This can be difficult and time-consuming. To avoid this problem, and easily solve families of equations containing multiple unknowns, a type of math was developed called Matrix theory.

Once the terminology and basic manipulations of matrices are understood, matrices can be used to readily solve large complex systems of equations.

The Matrix

We define a matrix as any rectangular array of numbers. Examples of matrices may be formed from the coefficients and constants of a system of linear equations: that is,

$$\begin{aligned} 2x - 4y &= 7 \\ 3x + y &= 16 \end{aligned}$$

can be written as follows.

$$\begin{bmatrix} 2 & -4 & 7 \\ 3 & 1 & 16 \end{bmatrix}$$

The numbers used in the matrix are called elements. In the example given, we have three columns and two rows of elements. The number of rows and columns are used to determine the dimensions of the matrix. In our example, the dimensions of the matrix are 2 x 3, having 2 rows and 3 columns of elements. In general, the dimensions of a matrix which have m rows and n columns is called an $m \times n$ matrix.

A matrix with only a single row or a single column is called either a row or a column matrix. A matrix which has the same number of rows as columns is called a square matrix. Examples of matrices and their dimensions are as follows:

$$\begin{bmatrix} 1 & 7 & 6 \\ 2 & 4 & 8 \end{bmatrix} = 2 \times 3$$

$$\begin{bmatrix} 1 & 7 \\ 6 & 2 \\ 3 & 5 \end{bmatrix} = 3 \times 2$$

$$\begin{bmatrix} 3 \\ 2 \\ 1 \end{bmatrix} = 3 \times 1$$

We will use capital letters to describe matrices. We will also include subscripts to give the dimensions.

$$A_{2 \times 3} = \begin{bmatrix} 1 & 3 & 3 \\ 5 & 6 & 7 \end{bmatrix}$$

Two matrices are said to be equal if, and only if, they have the same dimensions, and their corresponding elements are equal. The following are all equal matrices:

$$\begin{bmatrix} 0 & 1 \\ 2 & 4 \end{bmatrix} = \begin{bmatrix} 0 & 1 \\ 2 & 4 \end{bmatrix} = \begin{bmatrix} 0 & \frac{1}{1} \\ \frac{6}{3} & 4 \end{bmatrix}$$

Addition of Matrices

Matrices may only be added if they both have the same dimensions. To add two matrices, each element is added to its corresponding element. The sum matrix has the same dimensions as the two being added.

Example:

Add matrix A to matrix B.

$$A = \begin{bmatrix} 6 & 2 & 6 \\ -1 & 3 & 0 \end{bmatrix} \quad B = \begin{bmatrix} 2 & 1 & 3 \\ 0 & -3 & 6 \end{bmatrix}$$

Solution:

$$\begin{aligned} A + B &= \begin{bmatrix} 6+2 & 2+1 & 6+3 \\ -1+0 & 3-3 & 0+6 \end{bmatrix} \\ &= \begin{bmatrix} 8 & 3 & 9 \\ -1 & 0 & 6 \end{bmatrix} \end{aligned}$$

Multiplication of a Scalar and a Matrix

When multiplying a matrix by a scalar (or number), we write "scalar K times matrix A ." Each element of the matrix is multiplied by the scalar. By example:

$$K = 3 \quad \text{and} \quad A = \begin{bmatrix} 2 & 3 \\ 1 & 7 \end{bmatrix}$$

then

$$\begin{aligned} 3 \times A &= 3 \begin{bmatrix} 2 & 3 \\ 1 & 7 \end{bmatrix} \\ &= \begin{bmatrix} 2 \cdot 3 & 3 \cdot 3 \\ 1 \cdot 3 & 7 \cdot 3 \end{bmatrix} \\ &= \begin{bmatrix} 6 & 9 \\ 3 & 21 \end{bmatrix} \end{aligned}$$

Multiplication of a Matrix by a Matrix

To multiply two matrices, the first matrix must have the same number of rows (m) as the second matrix has columns (n). In other words, m of the first matrix must equal n of the second matrix. For example, a 2×1 matrix can be multiplied by a 1×2 matrix,

$$\begin{bmatrix} x \\ y \end{bmatrix} \begin{bmatrix} a & b \end{bmatrix} = \begin{bmatrix} ax & bx \\ ay & by \end{bmatrix}$$

or a 2×2 matrix can be multiplied by a 2×2 . If an $m \times n$ matrix is multiplied by an $n \times p$ matrix, then the resulting matrix is an $m \times p$ matrix. For example, if a 2×1 and a 1×2 are multiplied, the result will be a 2×2 . If a 2×2 and a 2×2 are multiplied, the result will be a 2×2 .

To multiply two matrices, the following pattern is used:

$$A = \begin{bmatrix} a & b \\ c & d \end{bmatrix} \quad B = \begin{bmatrix} w & x \\ y & z \end{bmatrix}$$

$$C = A \cdot B = \begin{bmatrix} aw+by & ax+bz \\ cw+dy & cx+dz \end{bmatrix}$$

In general terms, a matrix C which is a product of two matrices, A and B , will have elements given by the following.

$$c_{ij} = a_{i1}b_{1j} + a_{i2}b_{2j} + \dots + a_{in}b_{nj}$$

where

i = i th row

j = j th column

Example:

Multiply the matrices $A \times B$.

$$A = \begin{bmatrix} 1 & 2 \\ 3 & 4 \end{bmatrix} \quad B = \begin{bmatrix} 3 & 5 \\ 0 & 6 \end{bmatrix}$$

Solution:

$$\begin{aligned}
 A \cdot B &= \begin{bmatrix} (1 \times 3) + (2 \times 0) & (1 \times 5) + (2 \times 6) \\ (3 \times 3) + (4 \times 0) & (3 \times 5) + (4 \times 6) \end{bmatrix} \\
 &= \begin{bmatrix} 3 + 0 & 5 + 12 \\ 9 + 0 & 15 + 24 \end{bmatrix} \\
 &= \begin{bmatrix} 3 & 17 \\ 9 & 39 \end{bmatrix}
 \end{aligned}$$

It should be noted that the multiplication of matrices is not usually commutative.

The Determinant

Square matrixes have a property called a determinant. When a determinant of a matrix is written, it is symbolized by vertical bars rather than brackets around the numbers. This differentiates the determinant from a matrix. The determinant of a matrix is the reduction of the matrix to a single scalar number. The determinant of a matrix is found by "expanding" the matrix. There are several methods of "expanding" a matrix and calculating it's determinant. In this lesson, we will only look at a method called "expansion by minors."

Before a large matrix determinant can be calculated, we must learn how to calculate the determinant of a 2 x 2 matrix. By definition, the determinant of a 2 x 2 matrix is calculated as follows:

$$A = \begin{vmatrix} a & b \\ c & d \end{vmatrix} = ad - bc$$

Example: Find the determinant of A.

$$A = \begin{vmatrix} 6 & 2 \\ -1 & 3 \end{vmatrix}$$

Solution:

$$\begin{aligned} A &= (6 \cdot 3) - (-1 \cdot 2) \\ &= 18 - (-2) \\ &= 18 + 2 \\ &= 20 \end{aligned}$$

To expand a matrix larger than a 2 x 2 requires that it be simplified down to several 2 x 2 matrices, which can then be solved for their determinant. It is easiest to explain the process by example.

Given the 3 x 3 matrix:

$$\begin{array}{ccc} 1 & 3 & 1 \\ 4 & 1 & 2 \\ 5 & 6 & 3 \end{array}$$

Any single row or column is picked. In this example, column one is selected. The matrix will be expanded using the elements from the first column. Each of the elements in the selected column will be multiplied by its minor starting with the first element in the column (1). A line is then drawn through all the elements in the same row and column as 1. Since this is a 3 x 3 matrix, that leaves a minor or 2 x 2 determinant. This resulting 2 x 2 determinant is called the minor of the element in the first row first column.

$$\begin{bmatrix} \begin{array}{|c|c|c|} \hline 1 & 3 & 1 \\ \hline 4 & 1 & 2 \\ \hline 5 & 6 & 3 \\ \hline \end{array} \end{bmatrix}$$

$$1 \begin{vmatrix} 1 & 2 \\ 6 & 3 \end{vmatrix}$$

The minor of element 4 is:

$$\begin{bmatrix} \textcircled{1} & 3 & 1 \\ \textcircled{4} & 1 & 2 \\ \textcircled{5} & 6 & 3 \end{bmatrix}$$

$$4 \begin{vmatrix} 3 & 1 \\ 6 & 3 \end{vmatrix}$$

The minor of element 5 is:

$$\begin{bmatrix} \textcircled{1} & 3 & 1 \\ 4 & 1 & 2 \\ \textcircled{5} & 6 & 3 \end{bmatrix}$$

$$5 \begin{vmatrix} 3 & 1 \\ 1 & 2 \end{vmatrix}$$

Each element is given a sign based on its position in the original determinant.

$$\begin{vmatrix} + & - & + \\ - & + & - \\ + & - & + \end{vmatrix}$$

The sign is positive (negative) if the sum of the row plus the column for the element is even (odd). This pattern can be expanded or reduced to any size determinant. The positive and negative signs are just alternated.

Each minor is now multiplied by its signed element and the determinant of the resulting 2 x 2 calculated.

$$1 \begin{bmatrix} 1 & 2 \\ 6 & 3 \end{bmatrix} = 1 [(1 \cdot 3) - (2 \cdot 6)] = 3 - (12) = -9$$

$$-4 \begin{bmatrix} 3 & 1 \\ 6 & 3 \end{bmatrix} = -4 [(3 \cdot 3) - (1 \cdot 6)] = -4 [9 - 6] = -12$$

$$5 \begin{bmatrix} 3 & 1 \\ 1 & 2 \end{bmatrix} = 5 [(3 \cdot 2) - (1 \cdot 1)] = 5 [6 - 1] = 25$$

$$\text{Determinant} = (-9) + (-12) + 25 = 4$$

Example:

Find the determinant of the following 3 x 3 matrix, expanding about row 1.

$$\begin{vmatrix} 3 & 1 & 2 \\ 4 & 5 & 6 \\ 0 & 1 & 4 \end{vmatrix}$$

Solution:

$$\begin{array}{l} \text{First} \\ \text{Minor} \end{array} \begin{bmatrix} \boxed{3} & 1 & \boxed{3} \\ 4 & 5 & 6 \\ \boxed{0} & 1 & 4 \end{bmatrix} = 3 \begin{vmatrix} 5 & 6 \\ 1 & 4 \end{vmatrix} = 3 (20 - 6) = 3 (14) = 42$$

$$\begin{array}{l} \text{Second} \\ \text{Minor} \end{array} \begin{bmatrix} \boxed{3} & \boxed{1} & \boxed{3} \\ 4 & 5 & 6 \\ 0 & \boxed{1} & 4 \end{bmatrix} = -1 \begin{vmatrix} 4 & 6 \\ 0 & 4 \end{vmatrix} = -1 (16 - 0) = -1 (16) = -16$$

$$\begin{array}{l} \text{Third} \\ \text{Minor} \end{array} \begin{bmatrix} \boxed{3} & 1 & \boxed{3} \\ 4 & 5 & \boxed{6} \\ 0 & 1 & \boxed{4} \end{bmatrix} = 3 \begin{vmatrix} 4 & 5 \\ 0 & 1 \end{vmatrix} = 3 (4 - 0) = 3 (4) = 12$$

$$\text{Determinant} = 42 + (-16) + (12) = 38$$

Using Matrices to Solve System of Linear Equation (Cramer's Rule)

Matrices and their determinant can be used to solve a system of equations. This method becomes especially attractive when large numbers of unknowns are involved. But the method is still useful in solving algebraic equations containing two and three unknowns.

In part one of this chapter, it was shown that equations could be organized such that their coefficients could be written as a matrix.

$$\begin{array}{l} ax + by = c \\ ex + fy = g \end{array}$$

where:

x and y are variables
 a , b , e , and f are the coefficients
 c and g are constants

The equations can be rewritten in matrix form as follows:

$$\begin{bmatrix} a & b \\ e & f \end{bmatrix} \begin{bmatrix} x \\ y \end{bmatrix} = \begin{bmatrix} c \\ g \end{bmatrix}$$

To solve for each variable, the matrix containing the constants (c, g) is substituted in place of the column containing the coefficients of the variable that we want to solve for (a, e or b, f). This new matrix is divided by the original coefficient matrix. This process is called "Cramer's Rule."

Example:

In the above problem to solve for x ,

$$x = \frac{\begin{vmatrix} c & b \\ g & f \end{vmatrix}}{\begin{vmatrix} a & b \\ e & f \end{vmatrix}}$$

and to solve for y ,

$$y = \frac{\begin{vmatrix} a & c \\ e & g \end{vmatrix}}{\begin{vmatrix} a & b \\ e & f \end{vmatrix}}$$

Example:

Solve the following two equations:

$$\begin{aligned} x + 2y &= 4 \\ -x + 3y &= 1 \end{aligned}$$

Solution:

$$x = \frac{\begin{vmatrix} 4 & 2 \\ 1 & 3 \end{vmatrix}}{\begin{vmatrix} 1 & 2 \\ -1 & 3 \end{vmatrix}}$$

$$y = \frac{\begin{vmatrix} 1 & 4 \\ -1 & 1 \end{vmatrix}}{\begin{vmatrix} 1 & 2 \\ -1 & 3 \end{vmatrix}}$$

solving each 2 x 2 for its determinant,

$$x = \frac{[(4 \cdot 3) - (1 \cdot 2)]}{[(1 \cdot 3) - (-1 \cdot 2)]} = \frac{12 - 2}{3 + 2} = \frac{10}{5} = 2$$

$$y = \frac{[(1 \cdot 1) - (-1 \cdot 4)]}{[(1 \cdot 3) - (-1 \cdot 2)]} = \frac{1 + 4}{3 + 2} = \frac{5}{5} = 1$$

$$x = 2 \quad \text{and} \quad y = 1$$

A 3 x 3 is solved by using the same logic, except each 3 x 3 must be expanded by minors to solve for the determinant.

Example:

Given the following three equations, solve for the three unknowns.

$$\begin{aligned} 2x + 3y - z &= 2 \\ x - 2y + 2z &= -10 \\ 3x + y - 2z &= 1 \end{aligned}$$

Solution:

$$x = \frac{\begin{vmatrix} 2 & 3 & -1 \\ -10 & -2 & 2 \\ 1 & 1 & -2 \end{vmatrix}}{\begin{vmatrix} 2 & 3 & -1 \\ 1 & -2 & 2 \\ 3 & 1 & -2 \end{vmatrix}}$$

$$y = \frac{\begin{vmatrix} 2 & 2 & -1 \\ 1 & -10 & 2 \\ 3 & 1 & -2 \end{vmatrix}}{\begin{vmatrix} 2 & 3 & -1 \\ 1 & -2 & 2 \\ 3 & 1 & -2 \end{vmatrix}}$$

$$z = \frac{\begin{vmatrix} 2 & 3 & 2 \\ 1 & -2 & -10 \\ 3 & 1 & 1 \end{vmatrix}}{\begin{vmatrix} 2 & 3 & -1 \\ 1 & -2 & 2 \\ 3 & 1 & -2 \end{vmatrix}}$$

Expanding the top matrix for x using the elements in the bottom row gives:

$$1 \begin{bmatrix} 3 & -1 \\ -2 & 2 \end{bmatrix} + (-1) \begin{bmatrix} 2 & -1 \\ -10 & 2 \end{bmatrix} + (-2) \begin{bmatrix} 2 & 3 \\ -10 & -2 \end{bmatrix} =$$

$$1(6 - 2) + (-1)(4 - 10) + (-2)(-4 + 30) =$$

$$4 + 6 - 52 = -42$$

Expanding the bottom matrix for x using the elements in the first column gives:

$$2 \begin{bmatrix} -2 & 2 \\ 1 & -2 \end{bmatrix} + (-1) \begin{bmatrix} 3 & -1 \\ 1 & -2 \end{bmatrix} + 3 \begin{bmatrix} 3 & -1 \\ -2 & 2 \end{bmatrix} =$$

$$2(4 - 2) + (-1)(-6 + 1) + 3(6 - 2) =$$

$$4 + 5 + 12 = 21$$

This gives:

$$x = \frac{-42}{21} = -2$$

y and z can be expanded using the same method.

$$y = 1$$

$$z = -3$$

Summary

The use of matrices and determinants is summarized below.

Matrices and Determinant Summary

The dimensions of a matrix are given as $m \times n$, where m = number of rows and n = number of columns.

The use of determinants and matrices to solve linear equations is done by:

- placing the coefficients and constants into a determinant format.
- substituting the constants in place of the coefficients of the variable to be solved for.
- dividing the new-formed substituted determinant by the original determinant of coefficients.
- expanding the determinant.

CALCULUS

Many practical problems can be solved using arithmetic and algebra; however, many other practical problems involve quantities that cannot be adequately described using numbers which have fixed values.

EO 4.1 STATE the graphical definition of a derivative.

EO 4.2 STATE the graphical definition of an integral.

Dynamic Systems

Arithmetic involves numbers that have fixed values. Algebra involves both literal and arithmetic numbers. Although the literal numbers in algebraic problems can change value from one calculation to the next, they also have fixed values in a given calculation. When a weight is dropped and allowed to fall freely, its velocity changes continually. The electric current in an alternating current circuit changes continually. Both of these quantities have a different value at successive instants of time. Physical systems that involve quantities that change continually are called dynamic systems. The solution of problems involving dynamic systems often involves mathematical techniques different from those described in arithmetic and algebra. Calculus involves all the same mathematical techniques involved in arithmetic and algebra, such as addition, subtraction, multiplication, division, equations, and functions, but it also involves several other techniques. These techniques are not difficult to understand because they can be developed using familiar physical systems, but they do involve new ideas and terminology.

There are many dynamic systems encountered in nuclear facility work. The decay of radioactive materials, the startup of a reactor, and a power change on a turbine generator all involve quantities which change continually. An analysis of these dynamic systems involves calculus. Although the operation of a nuclear facility does not require a detailed understanding of calculus, it is most helpful to understand certain of the basic ideas and terminology involved. These ideas and terminology are encountered frequently, and a brief introduction to the basic ideas and terminology of the mathematics of dynamic systems is discussed in this chapter.

Differentials and Derivatives

One of the most commonly encountered applications of the mathematics of dynamic systems involves the relationship between position and time for a moving object. Figure 2 represents an object moving in a straight line from position P_1 to position P_2 . The distance to P_1 from a fixed reference point, point 0, along the line of travel is represented by S_1 ; the distance to P_2 from point 0 by S_2 .

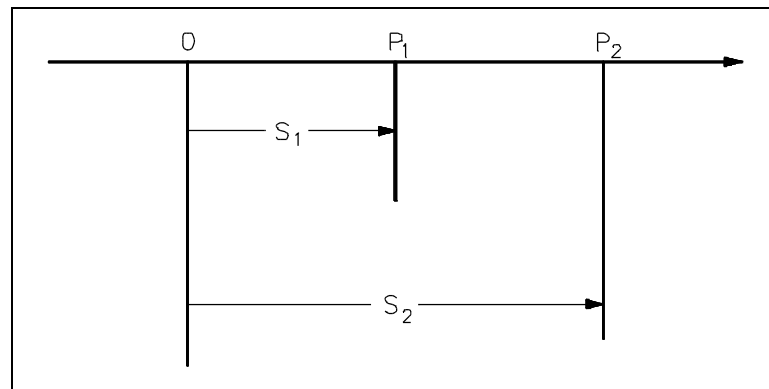

Figure 2 Motion Between Two Points

If the time recorded by a clock, when the object is at position P_1 is t_1 , and if the time when the object is at position P_2 is t_2 , then the average velocity of the object between points P_1 and P_2 equals the distance traveled, divided by the elapsed time.

$$V_{av} = \frac{S_2 - S_1}{t_2 - t_1} \quad (5-1)$$

If positions P_1 and P_2 are close together, the distance traveled and the elapsed time are small. The symbol Δ , the Greek letter delta, is used to denote changes in quantities. Thus, the average velocity when positions P_1 and P_2 are close together is often written using deltas.

$$V_{av} = \frac{\Delta S}{\Delta t} = \frac{S_2 - S_1}{t_2 - t_1} \quad (5-2)$$

Although the average velocity is often an important quantity, in many cases it is necessary to know the velocity at a given instant of time. This velocity, called the instantaneous velocity, is not the same as the average velocity, unless the velocity is not changing with time.

Using the graph of displacement, S , versus time, t , in Figure 3, we will try to describe the concept of the derivative.

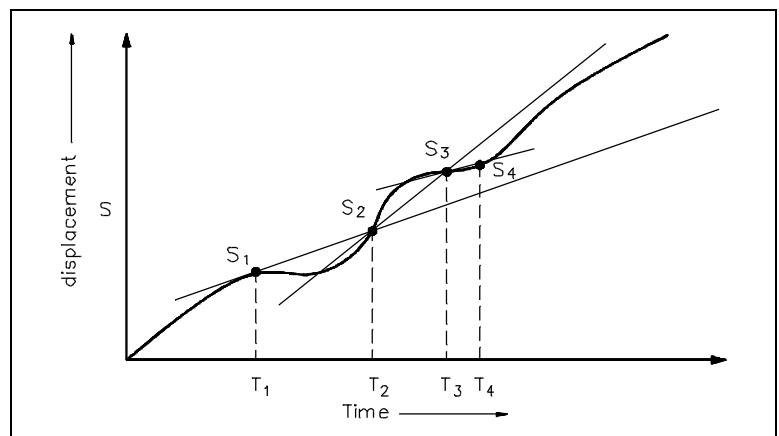

Figure 3 Displacement Versus Time

Using equation 5-1 we find the average velocity from S_1 to S_2 is $\frac{S_2 - S_1}{t_2 - t_1}$. If we connect the points S_1 and S_2 by a straight line we see it does not accurately reflect the slope of the curved line through all the points between S_1 and S_2 . Similarly, if we look at the average velocity between time t_2 and t_3 (a smaller period of time), we see the straight line connecting S_2 and S_3 more closely follows the curved line. Assuming the time between t_3 and t_4 is less than between t_2 and t_3 , the straight line connecting S_3 and S_4 very closely approximates the curved line between S_3 and S_4 .

As we further decrease the time interval between successive points, the expression $\frac{\Delta S}{\Delta t}$ more closely approximates the slope of the displacement curve. As $\Delta t \rightarrow 0$, $\frac{\Delta S}{\Delta t}$ approaches the instantaneous velocity. The expression for the derivative (in this case the slope of the displacement curve) can be written $\frac{dS}{dt} = \lim_{\Delta t \rightarrow 0} \frac{\Delta S}{\Delta t}$. In words, this expression would be

"the derivative of S with respect to time (t) is the limit of $\frac{\Delta S}{\Delta t}$ as Δt approaches 0."

$$V = \frac{ds}{dt} = \lim_{\Delta t \rightarrow 0} \frac{\Delta s}{\Delta t} \quad (5-3)$$

The symbols ds and dt are not products of d and s , or of d and t , as in algebra. Each represents a single quantity. They are pronounced "dee-ess" and "dee-tee," respectively. These expressions and the quantities they represent are called differentials. Thus, ds is the differential of s and dt is the differential of t . These expressions represent incremental changes, where ds represents an incremental change in distance s , and dt represents an incremental change in time t .

The combined expression ds/dt is called a derivative; it is the derivative of s with respect to t . It is read as "dee-ess dee-tee." dz/dx is the derivative of z with respect to x ; it is read as "dee-zee dee-ex." In simplest terms, a derivative expresses the rate of change of one quantity with respect to another. Thus, ds/dt is the rate of change of distance with respect to time. Referring to figure 3, the derivative ds/dt is the instantaneous velocity at any chosen point along the curve. This value of instantaneous velocity is numerically equal to the slope of the curve at that chosen point.

While the equation for instantaneous velocity, $V = ds/dt$, may seem like a complicated expression, it is a familiar relationship. Instantaneous velocity is precisely the value given by the speedometer of a moving car. Thus, the speedometer gives the value of the rate of change of distance with respect to time; it gives the derivative of s with respect to t ; i.e. it gives the value of ds/dt .

The ideas of differentials and derivatives are fundamental to the application of mathematics to dynamic systems. They are used not only to express relationships among distance traveled, elapsed time and velocity, but also to express relationships among many different physical quantities. One of the most important parts of understanding these ideas is having a physical interpretation of their meaning. For example, when a relationship is written using a differential or a derivative, the physical meaning in terms of incremental changes or rates of change should be readily understood.

When expressions are written using deltas, they can be understood in terms of changes. Thus, the expression ΔT , where T is the symbol for temperature, represents a change in temperature. As previously discussed, a lower case delta, d , is used to represent very small changes. Thus, dT represents a very small change in temperature. The fractional change in a physical quantity is the change divided by the value of the quantity. Thus, dT is an incremental change in temperature, and dT/T is a fractional change in temperature. When expressions are written as derivatives, they can be understood in terms of rates of change. Thus, dT/dt is the rate of change of temperature with respect to time.

Examples:

1. Interpret the expression $\Delta V/V$, and write it in terms of a differential. $\Delta V/V$ expresses the fractional change of velocity. It is the change in velocity divided by the velocity. It can be written as a differential when ΔV is taken as an incremental change.

$$\frac{\Delta V}{V} \text{ may be written as } \frac{dV}{V}$$

2. Give the physical interpretation of the following equation relating the work W done when a force F moves a body through a distance x .

$$dW = Fdx$$

This equation includes the differentials dW and dx which can be interpreted in terms of incremental changes. The incremental amount of work done equals the force applied multiplied by the incremental distance moved.

3. Give the physical interpretation of the following equation relating the force, F , applied to an object, its mass m , its instantaneous velocity v and time t .

$$F = m \frac{dv}{dt}$$

This equation includes the derivative dv/dt ; the derivative of the velocity with respect to time. It is the rate of change of velocity with respect to time. The force applied to an object equals the mass of the object multiplied by the rate of change of velocity with respect to time.

4. Give the physical interpretation of the following equation relating the acceleration a , the velocity v , and the time t .

$$a = \frac{dv}{dt}$$

This equation includes the derivative dv/dt ; the derivative of the velocity with respect to time. It is a rate of change. The acceleration equals the rate of change of velocity with respect to time.

Graphical Understanding of Derivatives

A function expresses a relationship between two or more variables. For example, the distance traveled by a moving body is a function of the body's velocity and the elapsed time. When a functional relationship is presented in graphical form, an important understanding of the meaning of derivatives can be developed.

Figure 4 is a graph of the distance traveled by an object as a function of the elapsed time. The functional relationship shown is given by the following equation:

$$s = 40t \tag{5-4}$$

The instantaneous velocity v , which is the velocity at a given instant of time, equals the derivative of the distance traveled with respect to time, ds/dt . It is the rate of change of s with respect to t .

The value of the derivative ds/dt for the case plotted in Figure 4 can be understood by considering small changes in the two variables s and t .

$$\frac{\Delta s}{\Delta t} = \frac{(s + \Delta s) - s}{(t + \Delta t) - t}$$

The values of $(s + \Delta s)$ and s in terms of $(t + \Delta t)$ and t , using Equation 5-4 can now be substituted into this expression. At time t , $s = 40t$; at time $t + \Delta t$, $s + \Delta s = 40(t + \Delta t)$.

$$\frac{\Delta s}{\Delta t} = \frac{40(t + \Delta t) - 40t}{(t + \Delta t) - t}$$

$$\frac{\Delta s}{\Delta t} = \frac{40t + 40(\Delta t) - 40t}{t + \Delta t - t}$$

$$\frac{\Delta s}{\Delta t} = \frac{40(\Delta t)}{\Delta t}$$

$$\frac{\Delta s}{\Delta t} = 40$$

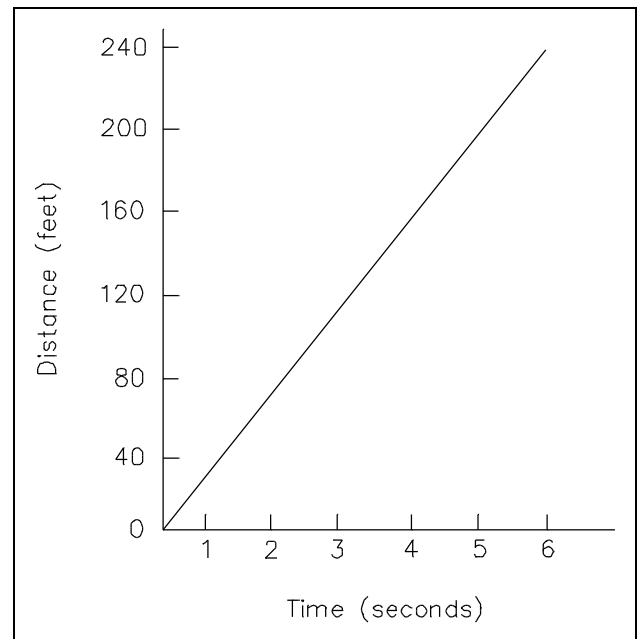

Figure 4 Graph of Distance vs. Time

The value of the derivative ds/dt in the case plotted in Figure 4 is a constant. It equals 40 ft/s. In the discussion of graphing, the slope of a straight line on a graph was defined as the change in y , Δy , divided by the change in x , Δx . The slope of the line in Figure 4 is $\Delta s/\Delta t$ which, in this case, is the value of the derivative ds/dt . Thus, derivatives of functions can be interpreted in terms of the slope of the graphical plot of the function. Since the velocity equals the derivative of the distance s with respect to time t , ds/dt , and since this derivative equals the slope of the plot of distance versus time, the velocity can be visualized as the slope of the graphical plot of distance versus time.

For the case shown in Figure 4, the velocity is constant. Figure 5 is another graph of the distance traveled by an object as a function of the elapsed time. In this case the velocity is not constant. The functional relationship shown is given by the following equation:

$$s = 10t^2 \tag{5-5}$$

The instantaneous velocity again equals the value of the derivative ds/dt . This value is changing with time. However, the instantaneous velocity at any specified time can be determined. First, small changes in s and t are considered.

$$\frac{\Delta s}{\Delta t} = \frac{(s + \Delta s) - s}{(t + \Delta t) - t}$$

The values of $(s + \Delta s)$ and s in terms of $(t + \Delta t)$ and t using Equation 5-5, can then be substituted into this expression. At time t , $s = 10t^2$; at time $t + \Delta t$, $s + \Delta s = 10(t + \Delta t)^2$. The value of $(t + \Delta t)^2$ equals $t^2 + 2t(\Delta t) + (\Delta t)^2$; however, for incremental values of Δt , the term $(\Delta t)^2$ is so small, it can be neglected. Thus, $(t + \Delta t)^2 = t^2 + 2t(\Delta t)$.

$$\frac{\Delta s}{\Delta t} = \frac{10[t^2 + 2t(\Delta t)] - 10t^2}{(t + \Delta t) - t}$$

$$\frac{\Delta s}{\Delta t} = \frac{10t^2 + 20t(\Delta t) - 10t^2}{t + \Delta t - t}$$

$$\frac{\Delta s}{\Delta t} = 20t$$

The value of the derivative ds/dt in the case plotted in Figure 5 equals $20t$. Thus, at time $t = 1$ s, the instantaneous velocity equals 20 ft/s; at time $t = 2$ s, the velocity equals 40 ft/s, and so on.

When the graph of a function is not a straight line, the slope of the plot is different at different points. The slope of a curve at any point is defined as the slope of a line drawn tangent to the curve at that point. Figure 6 shows a line drawn tangent to a curve. A tangent line is a line that touches the curve at only one point. The line AB is tangent to the

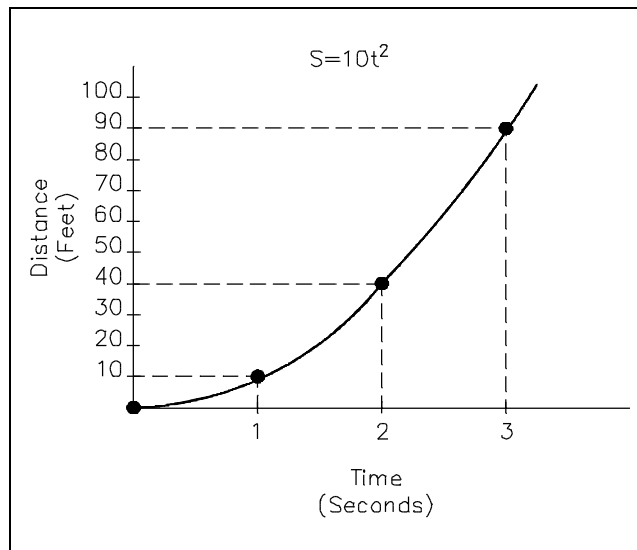

Figure 5 Graph of Distance vs. Time

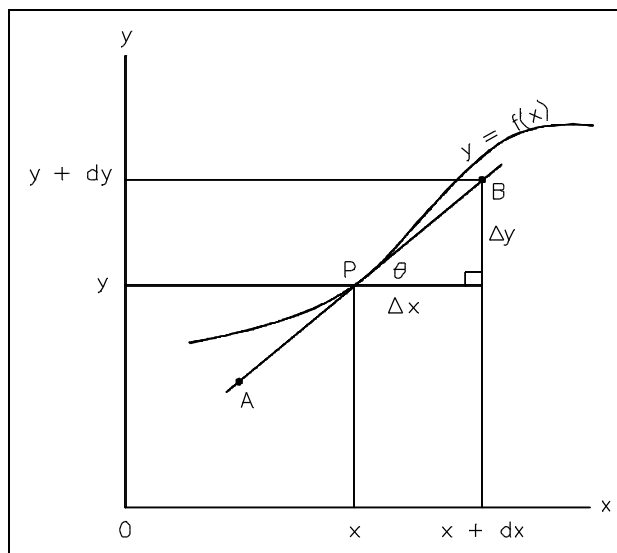

Figure 6 Slope of a Curve

curve $y = f(x)$ at point P .

The tangent line has the slope of the curve dy/dx , where, θ is the angle between the tangent line AB and a line parallel to the x -axis. But, $\tan \theta$ also equals $\Delta y/\Delta x$ for the tangent line AB , and $\Delta y/\Delta x$ is the slope of the line. Thus, the slope of a curve at any point equals the slope of the line drawn tangent to the curve at that point. This slope, in turn, equals the derivative of y with respect to x , dy/dx , evaluated at the same point.

These applications suggest that a derivative can be visualized as the slope of a graphical plot. A derivative represents the rate of change of one quantity with respect to another. When the relationship between these two quantities is presented in graphical form, this rate of change equals the slope of the resulting plot.

The mathematics of dynamic systems involves many different operations with the derivatives of functions. In practice, derivatives of functions are not determined by plotting the functions and finding the slopes of tangent lines. Although this approach could be used, techniques have been developed that permit derivatives of functions to be determined directly based on the form of the functions. For example, the derivative of the function $f(x) = c$, where c is a constant, is zero. The graph of a constant function is a horizontal line, and the slope of a horizontal line is zero.

$$f(x) = c$$

$$\frac{d[f(x)]}{dx} = 0 \quad (5-6)$$

The derivative of the function $f(x) = ax + c$ (compare to slope m from general form of linear equation, $y = mx + b$), where a and c are constants, is a . The graph of such a function is a straight line having a slope equal to a .

$$f(x) = ax + c$$

$$\frac{d[f(x)]}{dx} = a \quad (5-7)$$

The derivative of the function $f(x) = ax^n$, where a and n are constants, is nax^{n-1} .

$$f(x) = ax^n$$

$$\frac{d[f(x)]}{dx} = nax^{n-1} \quad (5-8)$$

The derivative of the function $f(x) = ae^{bx}$, where a and b are constants and e is the base of natural logarithms, is abe^{bx} .

$$f(x) = ae^{bx}$$

$$\frac{d[f(x)]}{dx} = abe^{bx} \quad (5-9)$$

These general techniques for finding the derivatives of functions are important for those who perform detailed mathematical calculations for dynamic systems. For example, the designers of nuclear facility systems need an understanding of these techniques, because these techniques are not encountered in the day-to-day operation of a nuclear facility. As a result, the operators of these facilities should understand what derivatives are in terms of a rate of change and a slope of a graph, but they will not normally be required to find the derivatives of functions.

The notation $d[f(x)]/dx$ is the common way to indicate the derivative of a function. In some applications, the notation $f'(x)$ is used. In other applications, the so-called dot notation is used to indicate the derivative of a function with respect to time. For example, the derivative of the amount of heat transferred, Q , with respect to time, dQ/dt , is often written as \dot{Q} .

It is also of interest to note that many detailed calculations for dynamic systems involve not only one derivative of a function, but several successive derivatives. The second derivative of a function is the derivative of its derivative; the third derivative is the derivative of the second derivative, and so on. For example, velocity is the first derivative of distance traveled with respect to time, $v = ds/dt$; acceleration is the derivative of velocity with respect to time, $a = dv/dt$. Thus, acceleration is the second derivative of distance traveled with respect to time. This is written as d^2s/dt^2 . The notation $d^2[f(x)]/dx^2$ is the common way to indicate the second derivative of a function. In some applications, the notation $f''(x)$ is used. The notation for third, fourth, and higher order derivatives follows this same format. Dot notation can also be used for higher order derivatives with respect to time. Two dots indicates the second derivative, three dots the third derivative, and so on.

Application of Derivatives to Physical Systems

There are many different problems involving dynamic physical systems that are most readily solved using derivatives. One of the best illustrations of the application of derivatives are problems involving related rates of change. When two quantities are related by some known physical relationship, their rates of change with respect to a third quantity are also related. For example, the area of a circle is related to its radius by the formula $A = \pi r^2$. If for some reason the size of a circle is changing in time, the rate of change of its area, with respect to time for example, is also related to the rate of change of its radius with respect to time. Although these applications involve finding the derivative of function, they illustrate why derivatives are needed to solve certain problems involving dynamic systems.

Example 1:

A stone is dropped into a quiet lake, and waves move in circles outward from the location of the splash at a constant velocity of 0.5 feet per second. Determine the rate at which the area of the circle is increasing when the radius is 4 feet.

Solution:

Using the formula for the area of a circle,

$$A = \pi r^2$$

take the derivative of both sides of this equation with respect to time t .

$$\frac{dA}{dt} = 2\pi r \frac{dr}{dt}$$

But, dr/dt is the velocity of the circle moving outward which equals 0.5 ft/s and dA/dt is the rate at which the area is increasing, which is the quantity to be determined. Set r equal to 4 feet, substitute the known values into the equation, and solve for dA/dt .

$$\frac{dA}{dt} = 2\pi r \frac{dr}{dt}$$

$$\frac{dA}{dt} = (2)(3.1416)(4 \text{ ft})(0.5 \text{ ft/s})$$

$$\frac{dA}{dt} = 12.6 \text{ ft}^2/\text{s}$$

Thus, at a radius of 4 feet, the area is increasing at a rate of 12.6 square feet per second.

Example 2:

A ladder 26 feet long is leaning against a wall. The ladder starts to move such that the bottom end moves away from the wall at a constant velocity of 2 feet per second. What is the downward velocity of the top end of the ladder when the bottom end is 10 feet from the wall?

Solution:

Start with the Pythagorean Theorem for a right triangle: $a^2 = c^2 - b^2$

Take the derivative of both sides of this equation with respect to time t . The c , representing the length of the ladder, is a constant.

$$2a \frac{da}{dt} = -2b \frac{db}{dt}$$

$$a \frac{da}{dt} = -b \frac{db}{dt}$$

But, db/dt is the velocity at which the bottom end of the ladder is moving away from the wall, equal to 2 ft/s, and da/dt is the downward velocity of the top end of the ladder along the wall, which is the quantity to be determined. Set b equal to 10 feet, substitute the known values into the equation, and solve for a .

$$a^2 = c^2 - b^2$$

$$a = \sqrt{c^2 - b^2}$$

$$a = \sqrt{(26 \text{ ft})^2 - (10 \text{ ft})^2}$$

$$a = \sqrt{676 \text{ ft}^2 - 100 \text{ ft}^2}$$

$$a = \sqrt{576 \text{ ft}^2}$$

$$a = 24 \text{ ft}$$

$$a \frac{da}{dt} = -b \frac{db}{dt}$$

$$\frac{da}{dt} = -\frac{b}{a} \frac{db}{dt}$$

$$\frac{da}{dt} = -\frac{10 \text{ ft}}{24 \text{ ft}} (2 \text{ ft/s})$$

$$\frac{da}{dt} = -0.833 \text{ ft/s}$$

Thus, when the bottom of the ladder is 10 feet from the wall and moving at 2ft/sec., the top of the ladder is moving downward at 0.833 ft/s. (The negative sign indicates the downward direction.)

Integrals and Summations in Physical Systems

Differentials and derivatives arose in physical systems when small changes in one quantity were considered. For example, the relationship between position and time for a moving object led to the definition of the instantaneous velocity, as the derivative of the distance traveled with respect to time, ds/dt . In many physical systems, rates of change are measured directly. Solving problems, when this is the case, involves another aspect of the mathematics of dynamic systems; namely integral and summations.

Figure 7 is a graph of the instantaneous velocity of an object as a function of elapsed time. This is the type of graph which could be generated if the reading of the speedometer of a car were recorded as a function of time.

At any given instant of time, the velocity of the object can be determined by referring to Figure 7. However, if the distance traveled in a certain interval of time is to be determined, some new techniques must be used. Consider the velocity versus time curve of Figure 7. Let's consider the velocity changes between times t_A and t_B . The first approach is to divide the time interval into three short intervals ($\Delta t_1, \Delta t_2, \Delta t_3$), and to assume that the velocity is constant during each of these intervals. During time interval Δt_1 , the velocity is assumed constant at an average velocity v_1 ; during the interval Δt_2 , the velocity is assumed constant at an average velocity v_2 ; during time interval Δt_3 , the velocity is assumed constant at an average velocity v_3 . Then the total distance traveled is approximately the sum of the products of the velocity and the elapsed time over each of the three intervals. Equation 5-10 approximates the distance traveled during the time interval from t_a to t_b and represents the approximate area under the velocity curve during this same time interval.

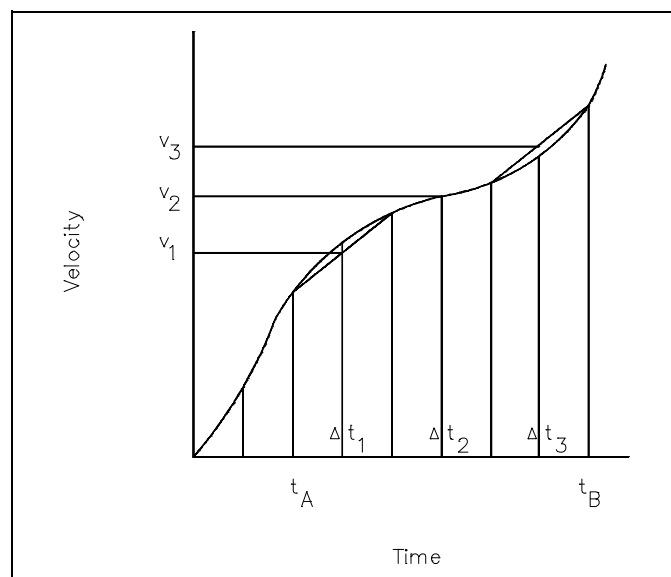

Figure 7 Graph of Velocity vs. Time

$$s = v_1\Delta t_1 + v_2\Delta t_2 + v_3\Delta t_3 \quad (5-10)$$

This type of expression is called a summation. A summation indicates the sum of a series of similar quantities. The upper case Greek letter Sigma, Σ , is used to indicate a summation. Generalized subscripts are used to simplify writing summations. For example, the summation given in Equation 5-10 would be written in the following manner:

$$S = \sum_{i=1}^3 v_i \Delta t_i \quad (5-11)$$

The number below the summation sign indicates the value of i in the first term of the summation; the number above the summation sign indicates the value of i in the last term of the summation.

The summation that results from dividing the time interval into three smaller intervals, as shown in Figure 7, only approximates the distance traveled. However, if the time interval is divided into incremental intervals, an exact answer can be obtained. When this is done, the distance traveled would be written as a summation with an indefinite number of terms.

$$S = \sum_{i=1}^{\infty} v_i \Delta t_i \quad (5-12)$$

This expression defines an integral. The symbol for an integral is an elongated "s" \int . Using an integral, Equation 5-12 would be written in the following manner:

$$S = \int_{t_A}^{t_B} v \, dt \quad (5-13)$$

This expression is read as S equals the integral of $v \, dt$ from $t = t_A$ to $t = t_B$. The numbers below and above the integral sign are the limits of the integral. The limits of an integral indicate the values at which the summation process, indicated by the integral, begins and ends.

As with differentials and derivatives, one of the most important parts of understanding integrals is having a physical interpretation of their meaning. For example, when a relationship is written as an integral, the physical meaning, in terms of a summation, should be readily understood. In the previous example, the distance traveled between t_A and t_B was approximated by equation 5-10. Equation 5-13 represents the exact distance traveled and also represents the exact area under the curve on figure 7 between t_A and t_B .

Examples:

1. Give the physical interpretation of the following equation relating the work, W , done when a force, F , moves a body from position x_1 to x_2 .

$$W = \int_{x_1}^{x_2} F \, dx$$

The physical meaning of this equation can be stated in terms of a summation. The total amount of work done equals the integral of $F \, dx$ from $x = x_1$ to $x = x_2$. This can be visualized as taking the product of the instantaneous force, F , and the incremental change in position dx at each point between x_1 and x_2 , and summing all of these products.

2. Give the physical interpretation of the following equation relating the amount of radioactive material present as a function of the elapsed time, t , and the decay constant, λ .

$$\int_{N_0}^{N_1} \frac{dN}{N} = -\lambda t$$

The physical meaning of this equation can be stated in terms of a summation. The negative of the product of the decay constant, λ , and the elapsed time, t , equals the integral of dN/N from $N = N_0$ to $n = n_1$. This integral can be visualized as taking the quotient of the incremental change in N , divided by the value of N at each point between N_0 and N_1 , and summing all of these quotients.

Graphical Understanding of Integral

As with derivatives, when a functional relationship is presented in graphical form, an important understanding of the meaning of integral can be developed.

Figure 8 is a plot of the instantaneous velocity, v , of an object as a function of elapsed time, t . The functional relationship shown is given by the following equation:

$$v = 6t \tag{5-14}$$

The distance traveled, s , between times t_A and t_B equals the integral of the velocity, v , with respect to time between the limits t_A and t_B .

$$s = \int_{t_A}^{t_B} v \, dt \tag{5-15}$$

The value of this integral can be determined for the case plotted in Figure 8 by noting that the velocity is increasing linearly. Thus, the average velocity for the time interval between t_A and t_B is the arithmetic average of the velocity at t_A and the velocity at t_B . At time t_A , $v = 6t_A$; at time t_B , $v = 6t_B$. Thus, the average velocity for the time interval between t_A and t_B is $\frac{6t_A + 6t_B}{2}$ which equals $3(t_A + t_B)$. Using this average velocity, the total distance traveled in the time interval between t_A and t_B is the product of the elapsed time $t_B - t_A$ and the average velocity $3(t_A + t_B)$.

$$s = v_{av}\Delta t$$

$$s = 3(t_A + t_B)(t_B - t_A) \quad (5-16)$$

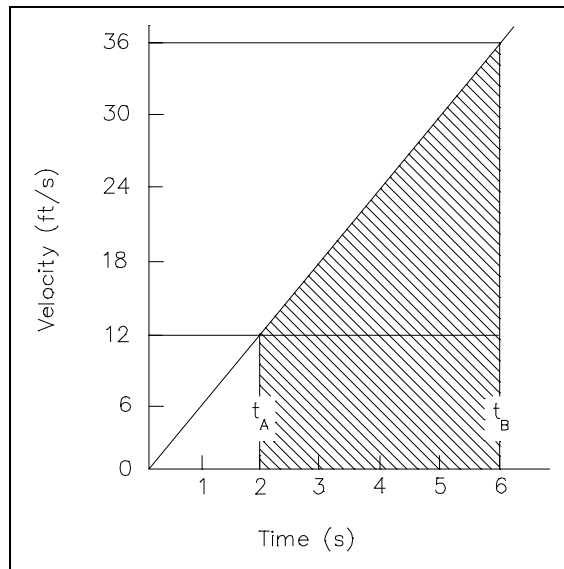

Figure 8 Graph of Velocity vs. Time

Equation 5-16 is also the value of the integral of the velocity, v , with respect to time, t , between the limits $t_A - t_B$ for the case plotted in Figure 8.

$$\int_{t_A}^{t_B} v dt = 3(t_A + t_B)(t_B - t_A)$$

The cross-hatched area in Figure 8 is the area under the velocity curve between $t = t_A$ and $t = t_B$. The value of this area can be computed by adding the area of the rectangle whose sides are $t_B - t_A$ and the velocity at t_A , which equals $6t_A - t_B$, and the area of the triangle whose base is $t_B - t_A$ and whose height is the difference between the velocity at t_B and the velocity at t_A , which equals $6t_B - t_A$.

$$\text{Area} = [(t_B - t_A)(6t_A)] + \left[\frac{1}{2}(t_B - t_A)(6t_B - 6t_A) \right]$$

$$\text{Area} = 6t_A t_B - 6t_A^2 + 3t_B^2 - 6t_A t_B + 3t_A^2$$

$$\text{Area} = 3t_B^2 - 3t_A^2$$

$$\text{Area} = 3(t_B + t_A)(t_B - t_A)$$

This is exactly equal to the value of the integral of the velocity with respect to time between the limits t_A and t_B . Since the distance traveled equals the integral of the velocity with respect to time, $\int v dt$, and since this integral equals the area under the curve of velocity versus time, the distance traveled can be visualized as the area under the curve of velocity versus time.

For the case shown in Figure 8, the velocity is increasing at a constant rate. When the plot of a function is not a straight line, the area under the curve is more difficult to determine. However, it can be shown that the integral of a function equals the area between the x-axis and the graphical plot of the function.

$$\int_{X_1}^{X_2} f(x) dx = \text{Area between } f(x) \text{ and x-axis from } x_1 \text{ to } x_2$$

The mathematics of dynamic systems involves many different operations with the integral of functions. As with derivatives, in practice, the integral of functions are not determined by plotting the functions and measuring the area under the curves. Although this approach could be used, techniques have been developed which permit integral of functions to be determined directly based on the form of the functions. Actually, the technique for taking an integral is the reverse of taking a derivative. For example, the derivative of the function $f(x) = ax + c$, where a and c are constants, is a . The integral of the function $f(x) = a$, where a is a constant, is $ax + c$, where a and c are constants.

$$f(x) = a$$

$$\int f(x) dx = ax + c \quad (5-17)$$

The integral of the function $f(x) = ax^n$, where a and n are constants, is $\frac{a}{n+1} x^{n+1} + c$, where c is another constant.

$$f(x) = ax^n$$

$$\int f(x) dx = \frac{a}{n+1} x^{n+1} + c \quad (5-18)$$

The integral of the function $f(x) = ae^{bx}$, where a and b are constants and e is the base of natural logarithms, is $\frac{ae^{bx}}{b} + c$, where c is another constant.

$$f(x) = ae^{bx}$$

$$\int f(x)dx = \frac{a}{b}e^{bx} + c \quad (5-19)$$

As with the techniques for finding the derivatives of functions, these general techniques for finding the integral of functions are primarily important only to those who perform detailed mathematical calculations for dynamic systems. These techniques are not encountered in the day-to-day operation of a nuclear facility. However, it is worthwhile to understand that taking an integral is the reverse of taking a derivative. It is important to understand what integral and derivatives are in terms of summations and areas under graphical plot, rates of change, and slopes of graphical plots.

Summary

The important information covered in this chapter is summarized below.

Derivatives and Differentials Summary

- The derivative of a function is defined as the rate of change of one quantity with respect to another, which is the slope of the function.
- The integral of a function is defined as the area under the curve.

end of text.

CONCLUDING MATERIAL

Review activities:

DOE - ANL-W, BNL, EG&G Idaho,
EG&G Mound, EG&G Rocky Flats,
LLNL, LANL, MMES, ORAU, REEC_o,
WHC, WINCO, WEMCO, and WSRC.

Preparing activity:

DOE - NE-73
Project Number 6910-0020/2