



DOE-HDBK-1012/2-92
JUNE 1992

DOE FUNDAMENTALS HANDBOOK

THERMODYNAMICS, HEAT TRANSFER, AND FLUID FLOW

Volume 2 of 3



U.S. Department of Energy
Washington, D.C. 20585

FSC-6910

Distribution Statement A. Approved for public release; distribution is unlimited.

This document has been reproduced directly from the best available copy.

Available to DOE and DOE contractors from the Office of Scientific and Technical Information. P. O. Box 62, Oak Ridge, TN 37831; prices available from (615) 576-8401. FTS 626-8401.

Available to the public from the National Technical Information Service, U.S. Department of Commerce, 5285 Port Royal Rd., Springfield, VA 22161.

Order No. DE92019790

ABSTRACT

The *Thermodynamics, Heat Transfer, and Fluid Flow Fundamentals Handbook* was developed to assist nuclear facility operating contractors provide operators, maintenance personnel, and the technical staff with the necessary fundamentals training to ensure a basic understanding of the thermal sciences. The handbook includes information on thermodynamics and the properties of fluids; the three modes of heat transfer - conduction, convection, and radiation; and fluid flow, and the energy relationships in fluid systems. This information will provide personnel with a foundation for understanding the basic operation of various types of DOE nuclear facility fluid systems.

Key Words: Training Material, Thermodynamics, Heat Transfer, Fluid Flow, Bernoulli's Equation

FOREWORD

The *Department of Energy (DOE) Fundamentals Handbooks* consist of ten academic subjects, which include Mathematics; Classical Physics; Thermodynamics, Heat Transfer, and Fluid Flow; Instrumentation and Control; Electrical Science; Material Science; Mechanical Science; Chemistry; Engineering Symbology, Prints, and Drawings; and Nuclear Physics and Reactor Theory. The handbooks are provided as an aid to DOE nuclear facility contractors.

These handbooks were first published as Reactor Operator Fundamentals Manuals in 1985 for use by DOE Category A reactors. The subject areas, subject matter content, and level of detail of the Reactor Operator Fundamentals Manuals was determined from several sources. DOE Category A reactor training managers determined which materials should be included, and served as a primary reference in the initial development phase. Training guidelines from the commercial nuclear power industry, results of job and task analyses, and independent input from contractors and operations-oriented personnel were all considered and included to some degree in developing the text material and learning objectives.

The *DOE Fundamentals Handbooks* represent the needs of various DOE nuclear facilities' fundamentals training requirements. To increase their applicability to nonreactor nuclear facilities, the Reactor Operator Fundamentals Manual learning objectives were distributed to the Nuclear Facility Training Coordination Program Steering Committee for review and comment. To update their reactor-specific content, DOE Category A reactor training managers also reviewed and commented on the content. On the basis of feedback from these sources, information that applied to two or more DOE nuclear facilities was considered generic and was included. The final draft of each of these handbooks was then reviewed by these two groups. This approach has resulted in revised modular handbooks that contain sufficient detail such that each facility may adjust the content to fit their specific needs.

Each handbook contains an abstract, a foreword, an overview, learning objectives, and text material, and is divided into modules so that content and order may be modified by individual DOE contractors to suit their specific training needs. Each subject area is supported by a separate examination bank with an answer key.

The *DOE Fundamentals Handbooks* have been prepared for the Assistant Secretary for Nuclear Energy, Office of Nuclear Safety Policy and Standards, by the DOE Training Coordination Program. This program is managed by EG&G Idaho, Inc.

OVERVIEW

The *Department of Energy Fundamentals Handbook* entitled *Thermodynamics, Heat Transfer, and Fluid Flow* was prepared as an information resource for personnel who are responsible for the operation of the Department's nuclear facilities. A basic understanding of the thermal sciences is necessary for DOE nuclear facility operators, maintenance personnel, and the technical staff to safely operate and maintain the facility and facility support systems. The information in the handbook is presented to provide a foundation for applying engineering concepts to the job. This knowledge will help personnel more fully understand the impact that their actions may have on the safe and reliable operation of facility components and systems.

The *Thermodynamics, Heat Transfer, and Fluid Flow* handbook consists of three modules that are contained in three volumes. The following is a brief description of the information presented in each module of the handbook.

Volume 1 of 3

Module 1 - Thermodynamics

This module explains the properties of fluids and how those properties are affected by various processes. The module also explains how energy balances can be performed on facility systems or components and how efficiency can be calculated.

Volume 2 of 3

Module 2 - Heat Transfer

This module describes conduction, convection, and radiation heat transfer. The module also explains how specific parameters can affect the rate of heat transfer.

Volume 3 of 3

Module 3 - Fluid Flow

This module describes the relationship between the different types of energy in a fluid stream through the use of Bernoulli's equation. The module also discusses the causes of head loss in fluid systems and what factors affect head loss.

THERMODYNAMICS, HEAT TRANSFER, AND FLUID FLOW

The information contained in this handbook is by no means all encompassing. An attempt to present the entire subject of thermodynamics, heat transfer, and fluid flow would be impractical. However, the *Thermodynamics, Heat Transfer, and Fluid Flow* handbook does present enough information to provide the reader with a fundamental knowledge level sufficient to understand the advanced theoretical concepts presented in other subject areas, and to better understand basic system and equipment operations.

**Department of Energy
Fundamentals Handbook**

**THERMODYNAMICS, HEAT TRANSFER,
AND FLUID FLOW,
Module 2
Heat Transfer**

TABLE OF CONTENTS

| | |
|--|-----|
| LIST OF FIGURES | iii |
| LIST OF TABLES | iv |
| REFERENCES | v |
| OBJECTIVES | vii |
| HEAT TRANSFER TERMINOLOGY | 1 |
| Heat and Temperature | 1 |
| Heat and Work | 2 |
| Modes of Transferring Heat | 2 |
| Heat Flux | 3 |
| Thermal Conductivity | 3 |
| Log Mean Temperature Difference | 3 |
| Convective Heat Transfer Coefficient | 4 |
| Overall Heat Transfer Coefficient | 4 |
| Bulk Temperature | 4 |
| Summary | 5 |
| CONDUCTION HEAT TRANSFER | 6 |
| Conduction | 6 |
| Conduction-Rectangular Coordinates | 7 |
| Equivalent Resistance Method | 9 |
| Electrical Analogy | 10 |
| Conduction-Cylindrical Coordinates | 11 |
| Summary | 17 |
| CONVECTION HEAT TRANSFER | 18 |
| Convection | 18 |
| Overall Heat Transfer Coefficient | 20 |
| Convection Heat Transfer | 23 |
| Summary | 25 |
| RADIANT HEAT TRANSFER | 26 |
| Thermal Radiation | 26 |
| Black Body Radiation | 26 |
| Emissivity | 27 |

TABLE OF CONTENTS (Cont.)

| | |
|--|-----------|
| Radiation Configuration Factor | 27 |
| Summary | 29 |
| HEAT EXCHANGERS | 30 |
| Heat Exchangers | 30 |
| Parallel and Counter-Flow Designs | 31 |
| Non-Regenerative Heat Exchanger | 34 |
| Regenerative Heat Exchanger | 34 |
| Cooling Towers | 35 |
| Log Mean Temperature Difference Application to Heat Exchangers | 36 |
| Overall Heat Transfer Coefficient | 37 |
| Summary | 39 |
| BOILING HEAT TRANSFER | 40 |
| Boiling | 40 |
| Nucleate Boiling | 40 |
| Bulk Boiling | 41 |
| Film Boiling | 41 |
| Departure from Nucleate Boiling and Critical Heat Flux | 42 |
| Summary | 43 |
| HEAT GENERATION | 44 |
| Heat Generation | 44 |
| Flux Profiles | 46 |
| Thermal Limits | 47 |
| Average Linear Power Density | 47 |
| Maximum Local Linear Power Density | 48 |
| Temperature Profiles | 48 |
| Volumetric Thermal Source Strength | 50 |
| Fuel Changes During Reactor Operation | 50 |
| Summary | 51 |
| DECAY HEAT | 52 |
| Reactor Decay Heat Production | 52 |
| Calculation of Decay heat | 53 |
| Decay Heat Limits | 55 |
| Decay Heat Removal | 56 |
| Summary | 57 |

LIST OF FIGURES

| | | |
|-----------|---|----|
| Figure 1 | Conduction Through a Slab | 7 |
| Figure 2 | Equivalent Resistance | 10 |
| Figure 3 | Cross-sectional Surface Area of a Cylindrical Pipe | 11 |
| Figure 4 | Composite Cylindrical Layers | 15 |
| Figure 5 | Pipe Insulation Problem | 16 |
| Figure 6 | Overall Heat Transfer Coefficient | 20 |
| Figure 7 | Combined Heat Transfer | 21 |
| Figure 8 | Typical Tube and Shell Heat Exchanger | 31 |
| Figure 9 | Fluid Flow Direction | 32 |
| Figure 10 | Heat Exchanger Temperature Profiles | 33 |
| Figure 11 | Non-Regenerative Heat Exchanger | 34 |
| Figure 12 | Regenerative Heat Exchanger | 35 |
| Figure 13 | Boiling Heat Transfer Curve | 42 |
| Figure 14 | Axial Flux Profile | 46 |
| Figure 15 | Radial Flux Profile | 46 |
| Figure 16 | Axial Temperature Profile | 48 |
| Figure 17 | Radial Temperature Profile Across a Fuel Rod and Coolant Channel | 49 |

LIST OF TABLES

NONE

REFERENCES

- VanWylen, G. J. and Sonntag, R. E., Fundamentals of Classical Thermodynamics SI Version, 2nd Edition, John Wiley and Sons, New York, ISBN 0-471-04188-2.
- Kreith, Frank, Principles of Heat Transfer, 3rd Edition, Intext Press, Inc., New York, ISBN 0-7002-2422-X.
- Holman, J. P., Thermodynamics, McGraw-Hill, New York.
- Streeter, Victor, L., Fluid Mechanics, 5th Edition, McGraw-Hill, New York, ISBN 07-062191-9.
- Rynolds, W. C. and Perkins, H. C., Engineering Thermodynamics, 2nd Edition, McGraw-Hill, New York, ISBN 0-07-052046-1.
- Meriam, J. L., Engineering Mechanics Statics and Dynamics, John Wiley and Sons, New York, ISBN 0-471-01979-8.
- Schneider, P. J. Conduction Heat Transfer, Addison-Wesley Pub. Co., California.
- Holman, J. P., Heat Transfer, 3rd Edition, McGraw-Hill, New York.
- Knudsen, J. G. and Katz, D. L., Fluid Dynamics and Heat Transfer, McGraw-Hill, New York.
- Kays, W. and London, A. L., Compact Heat Exchangers, 2nd Edition, McGraw-Hill, New York.
- Weibelt, J. A., Engineering Radiation Heat Transfer, Holt, Rinehart and Winston Publish., New York.
- Sparrow, E. M. and Cess, R. E., Radiation Heat Transfer, Brooks/Cole Publish. Co., Belmont, California.
- Hamilton, D. C. and Morgan, N. R., Radiant-Interchange Configuration Factors, Tech. Note 2836, National Advisory Committee for Aeronautics.
- McDonald, A. T. and Fox, R. W., Introduction to Fluid mechanics, 2nd Edition, John Wiley and Sons, New York, ISBN 0-471-01909-7.

REFERENCES (Cont.)

- Zucrow, M. J. and Hoffman, J. D., Gas Dynamics Vol.b1, John Wiley and Sons, New York, ISBN 0-471-98440-X.
- Crane Company, Flow of Fluids Through Valves, Fittings, and Pipe, Crane Co. Technical Paper No. 410, Chicago, Illinois, 1957.
- Esposito, Anthony, Fluid Power with Applications, Prentice-Hall, Inc., New Jersey, ISBN 0-13-322701-4.
- Beckwith, T. G. and Buck, N. L., Mechanical Measurements, Addison-Wesley Publish Co., California.
- Wallis, Graham, One-Dimensional Two-Phase Flow, McGraw-Hill, New York, 1969.
- Kays, W. and Crawford, M. E., Convective Heat and Mass Transfer, McGraw-Hill, New York, ISBN 0-07-03345-9.
- Collier, J. G., Convective Boiling and Condensation, McGraw-Hill, New York, ISBN 07-084402-X.
- Academic Program for Nuclear Power Plant Personnel, Volumes III and IV, Columbia, MD: General Physics Corporation, Library of Congress Card #A 326517, 1982.
- Faires, Virgel Moring and Simmang, Clifford Max, Thermodynamics, MacMillan Publishing Co. Inc., New York.

TERMINAL OBJECTIVE

- 1.0 Given the operating conditions of a thermodynamic system and the necessary formulas, **EVALUATE** the heat transfer processes which are occurring.

ENABLING OBJECTIVES

- 1.1 **DESCRIBE** the difference between heat and temperature.
- 1.2 **DESCRIBE** the difference between heat and work.
- 1.3 **DESCRIBE** the Second Law of Thermodynamics and how it relates to heat transfer.
- 1.4 **DESCRIBE** the three modes of heat transfer.
- 1.5 **DEFINE** the following terms as they relate to heat transfer:
- Heat flux
 - Thermal conductivity
 - Log mean temperature difference
 - Convective heat transfer coefficient
 - Overall heat transfer coefficient
 - Bulk temperature
- 1.6 Given Fourier's Law of Conduction, **CALCULATE** the conduction heat flux in a rectangular coordinate system.
- 1.7 Given the formula and the necessary values, **CALCULATE** the equivalent thermal resistance.
- 1.8 Given Fourier's Law of Conduction, **CALCULATE** the conduction heat flux in a cylindrical coordinate system.
- 1.9 Given the formula for heat transfer and the operating conditions of the system, **CALCULATE** the rate of heat transfer by convection.
- 1.10 **DESCRIBE** how the following terms relate to radiant heat transfer:
- Black body radiation
 - Emissivity
 - Radiation configuration factor

ENABLING OBJECTIVES (Cont.)

- 1.11 **DESCRIBE** the difference in the temperature profiles for counter-flow and parallel flow heat exchangers.
- 1.12 **DESCRIBE** the differences between regenerative and non-regenerative heat exchangers.
- 1.13 Given the temperature changes across a heat exchanger, **CALCULATE** the log mean temperature difference for the heat exchanger.
- 1.14 Given the formulas for calculating the conduction and convection heat transfer coefficients, **CALCULATE** the overall heat transfer coefficient of a system.
- 1.15 **DESCRIBE** the process that occurs in the following regions of the boiling heat transfer curve:
- a. Nucleate boiling
 - b. Partial film boiling
 - c. Film boiling
 - d. Departure from nucleate boiling (DNB)
 - e. Critical heat flux

TERMINAL OBJECTIVE

- 2.0 Given the operating conditions of a typical nuclear reactor, **DESCRIBE** the heat transfer processes which are occurring.

ENABLING OBJECTIVES

- 2.1 **DESCRIBE** the power generation process in a nuclear reactor core and the factors that affect the power generation.
- 2.2 **DESCRIBE** the relationship between temperature, flow, and power during operation of a nuclear reactor.
- 2.3 **DEFINE** the following terms:
- a. Nuclear enthalpy rise hot channel factor
 - b. Average linear power density
 - c. Nuclear heat flux hot channel factor
 - d. Heat generation rate of a core
 - e. Volumetric thermal source strength
- 2.4 **CALCULATE** the average linear power density for an average reactor core fuel rod.
- 2.5 **DESCRIBE** a typical reactor core axial and radial flux profile.
- 2.6 **DESCRIBE** a typical reactor core fuel rod axial and radial temperature profile.
- 2.7 **DEFINE** the term decay heat.
- 2.8 Given the operating conditions of a reactor core and the necessary formulas, **CALCULATE** the core decay heat generation.
- 2.9 **DESCRIBE** two categories of methods for removing decay heat from a reactor core.

Intentionally Left Blank

HEAT TRANSFER TERMINOLOGY

To understand and communicate in the thermal science field, certain terms and expressions must be learned in heat transfer.

- EO 1.1** **DESCRIBE the difference between heat and temperature.**
- EO 1.2** **DESCRIBE the difference between heat and work.**
- EO 1.3** **DESCRIBE the Second Law of Thermodynamics and how it relates to heat transfer.**
- EO 1.4** **DESCRIBE the three modes of heat transfer.**
- EO 1.5** **DEFINE the following terms as they relate to heat transfer:**
- a.** **Heat flux**
 - b.** **Thermal conductivity**
 - c.** **Log mean temperature difference**
 - d.** **Convective heat transfer coefficient**
 - e.** **Overall heat transfer coefficient**
 - f.** **Bulk temperature**

Heat and Temperature

In describing heat transfer problems, students often make the mistake of interchangeably using the terms heat and temperature. Actually, there is a distinct difference between the two. *Temperature* is a measure of the amount of energy possessed by the molecules of a substance. It is a relative measure of how hot or cold a substance is and can be used to predict the direction of heat transfer. The symbol for temperature is T. The common scales for measuring temperature are the Fahrenheit, Rankine, Celsius, and Kelvin temperature scales.

Heat is energy in transit. The transfer of energy as heat occurs at the molecular level as a result of a temperature difference. Heat is capable of being transmitted through solids and fluids by conduction, through fluids by convection, and through empty space by radiation. The symbol for heat is Q. Common units for measuring heat are the British Thermal Unit (Btu) in the English system of units and the calorie in the SI system (International System of Units).

Heat and Work

Distinction should also be made between the energy terms *heat* and *work*. Both represent energy in transition. Work is the transfer of energy resulting from a force acting through a distance. Heat is energy transferred as the result of a temperature difference. Neither heat nor work are thermodynamic properties of a system. Heat can be transferred into or out of a system and work can be done on or by a system, but a system cannot contain or store either heat or work. Heat into a system and work out of a system are considered positive quantities.

When a temperature difference exists across a boundary, the Second Law of Thermodynamics indicates the natural flow of energy is from the hotter body to the colder body. The Second Law of Thermodynamics denies the possibility of ever completely converting into work all the heat supplied to a system operating in a cycle. The Second Law of Thermodynamics, described by Max Planck in 1903, states that:

It is impossible to construct an engine that will work in a complete cycle and produce no other effect except the raising of a weight and the cooling of a reservoir.

The second law says that if you draw heat from a reservoir to raise a weight, lowering the weight will not generate enough heat to return the reservoir to its original temperature, and eventually the cycle will stop. If two blocks of metal at different temperatures are thermally insulated from their surroundings and are brought into contact with each other the heat will flow from the hotter to the colder. Eventually the two blocks will reach the same temperature, and heat transfer will cease. Energy has not been lost, but instead some energy has been transferred from one block to another.

Modes of Transferring Heat

Heat is always transferred when a temperature difference exists between two bodies. There are three basic modes of heat transfer:

Conduction involves the transfer of heat by the interactions of atoms or molecules of a material through which the heat is being transferred.

Convection involves the transfer of heat by the mixing and motion of macroscopic portions of a fluid.

Radiation, or radiant heat transfer, involves the transfer of heat by electromagnetic radiation that arises due to the temperature of a body.

The three modes of heat transfer will be discussed in greater detail in the subsequent chapters of this module.

Heat Flux

The rate at which heat is transferred is represented by the symbol \dot{Q} . Common units for heat transfer rate is Btu/hr. Sometimes it is important to determine the heat transfer rate per unit area, or *heat flux*, which has the symbol \dot{Q}'' . Units for heat flux are Btu/hr-ft². The heat flux can be determined by dividing the heat transfer rate by the area through which the heat is being transferred.

$$\dot{Q}'' = \frac{\dot{Q}}{A} \quad (2-1)$$

where:

$$\dot{Q}'' = \text{heat flux (Btu/hr-ft}^2\text{)}$$

$$\dot{Q} = \text{heat transfer rate (Btu/hr)}$$

$$A = \text{area (ft}^2\text{)}$$

Thermal Conductivity

The heat transfer characteristics of a solid material are measured by a property called the *thermal conductivity* (k) measured in Btu/hr-ft-°F. It is a measure of a substance's ability to transfer heat through a solid by conduction. The thermal conductivity of most liquids and solids varies with temperature. For vapors, it depends upon pressure.

Log Mean Temperature Difference

In heat exchanger applications, the inlet and outlet temperatures are commonly specified based on the fluid in the tubes. The temperature change that takes place across the heat exchanger from the entrance to the exit is not linear. A precise temperature change between two fluids across the heat exchanger is best represented by the *log mean temperature difference* (LMTD or ΔT_{lm}), defined in Equation 2-2.

$$\Delta T_{lm} = \frac{(\Delta T_2 - \Delta T_1)}{\ln(\Delta T_2/\Delta T_1)} \quad (2-2)$$

where:

$$\Delta T_2 = \text{the larger temperature difference between the two fluid streams at either the entrance or the exit to the heat exchanger}$$

$$\Delta T_1 = \text{the smaller temperature difference between the two fluid streams at either the entrance or the exit to the heat exchanger}$$

Convective Heat Transfer Coefficient

The convective heat transfer coefficient (h), defines, in part, the heat transfer due to convection. The *convective heat transfer coefficient* is sometimes referred to as a film coefficient and represents the thermal resistance of a relatively stagnant layer of fluid between a heat transfer surface and the fluid medium. Common units used to measure the convective heat transfer coefficient are Btu/hr - ft² - °F.

Overall Heat Transfer Coefficient

In the case of combined heat transfer, it is common practice to relate the total rate of heat transfer (\dot{Q}), the overall cross-sectional area for heat transfer (A_o), and the overall temperature difference (ΔT_o) using the overall heat transfer coefficient (U_o). The *overall heat transfer coefficient* combines the heat transfer coefficient of the two heat exchanger fluids and the thermal conductivity of the heat exchanger tubes. U_o is specific to the heat exchanger and the fluids that are used in the heat exchanger.

$$\dot{Q} = U_o A_o \Delta T_o \quad (2-3)$$

where:

\dot{Q} = the rate heat of transfer (Btu/hr)

U_o = the overall heat transfer coefficient (Btu/hr - ft² - °F)

A_o = the overall cross-sectional area for heat transfer (ft²)

ΔT_o = the overall temperature difference (°F)

Bulk Temperature

The fluid temperature (T_b), referred to as the *bulk temperature*, varies according to the details of the situation. For flow adjacent to a hot or cold surface, T_b is the temperature of the fluid that is "far" from the surface, for instance, the center of the flow channel. For boiling or condensation, T_b is equal to the saturation temperature.

Summary

The important information in this chapter is summarized below.

Heat Transfer Terminology Summary

- Heat is energy transferred as a result of a temperature difference.
- Temperature is a measure of the amount of molecular energy contained in a substance.
- Work is a transfer of energy resulting from a force acting through a distance.
- The Second Law of Thermodynamics implies that heat will not transfer from a colder to a hotter body without some external source of energy.
- Conduction involves the transfer of heat by the interactions of atoms or molecules of a material through which the heat is being transferred.
- Convection involves the transfer of heat by the mixing and motion of macroscopic portions of a fluid.
- Radiation, or radiant heat transfer, involves the transfer of heat by electromagnetic radiation that arises due to the temperature of a body.
- Heat flux is the rate of heat transfer per unit area.
- Thermal conductivity is a measure of a substance's ability to transfer heat through itself.
- Log mean temperature difference is the ΔT that most accurately represents the ΔT for a heat exchanger.
- The local heat transfer coefficient represents a measure of the ability to transfer heat through a stagnant film layer.
- The overall heat transfer coefficient is the measure of the ability of a heat exchanger to transfer heat from one fluid to another.
- The bulk temperature is the temperature of the fluid that best represents the majority of the fluid which is not physically connected to the heat transfer site.

CONDUCTION HEAT TRANSFER

Conduction heat transfer is the transfer of thermal energy by interactions between adjacent atoms and molecules of a solid.

EO 1.6 **Given Fourier's Law of Conduction, CALCULATE the conduction heat flux in a rectangular coordinate system.**

EO 1.7 **Given the formula and the necessary values, CALCULATE the equivalent thermal resistance.**

EO 1.8 **Given Fourier's Law of Conduction, CALCULATE the conduction heat flux in a cylindrical coordinate system.**

Conduction

Conduction involves the transfer of heat by the interaction between adjacent molecules of a material. Heat transfer by conduction is dependent upon the driving "force" of temperature difference and the resistance to heat transfer. The resistance to heat transfer is dependent upon the nature and dimensions of the heat transfer medium. All heat transfer problems involve the temperature difference, the geometry, and the physical properties of the object being studied.

In conduction heat transfer problems, the object being studied is usually a solid. Convection problems involve a fluid medium. Radiation heat transfer problems involve either solid or fluid surfaces, separated by a gas, vapor, or vacuum. There are several ways to correlate the geometry, physical properties, and temperature difference of an object with the rate of heat transfer through the object. In conduction heat transfer, the most common means of correlation is through Fourier's Law of Conduction. The law, in its equation form, is used most often in its rectangular or cylindrical form (pipes and cylinders), both of which are presented below.

$$\text{Rectangular} \quad \dot{Q} = k A \left(\frac{\Delta T}{\Delta x} \right) \quad (2-4)$$

$$\text{Cylindrical} \quad \dot{Q} = k A \left(\frac{\Delta T}{\Delta r} \right) \quad (2-5)$$

where:

- \dot{Q} = rate of heat transfer (Btu/hr)
- A = cross-sectional area of heat transfer (ft²)
- Δx = thickness of slab (ft)
- Δr = thickness of cylindrical wall (ft)
- ΔT = temperature difference (°F)
- k = thermal conductivity of slab (Btu/ft-hr-°F)

The use of Equations 2-4 and 2-5 in determining the amount of heat transferred by conduction is demonstrated in the following examples.

Conduction-Rectangular Coordinates

Example:

1000 Btu/hr is conducted through a section of insulating material shown in Figure 1 that measures 1 ft² in cross-sectional area. The thickness is 1 in. and the thermal conductivity is 0.12 Btu/hr-ft-°F. Compute the temperature difference across the material.

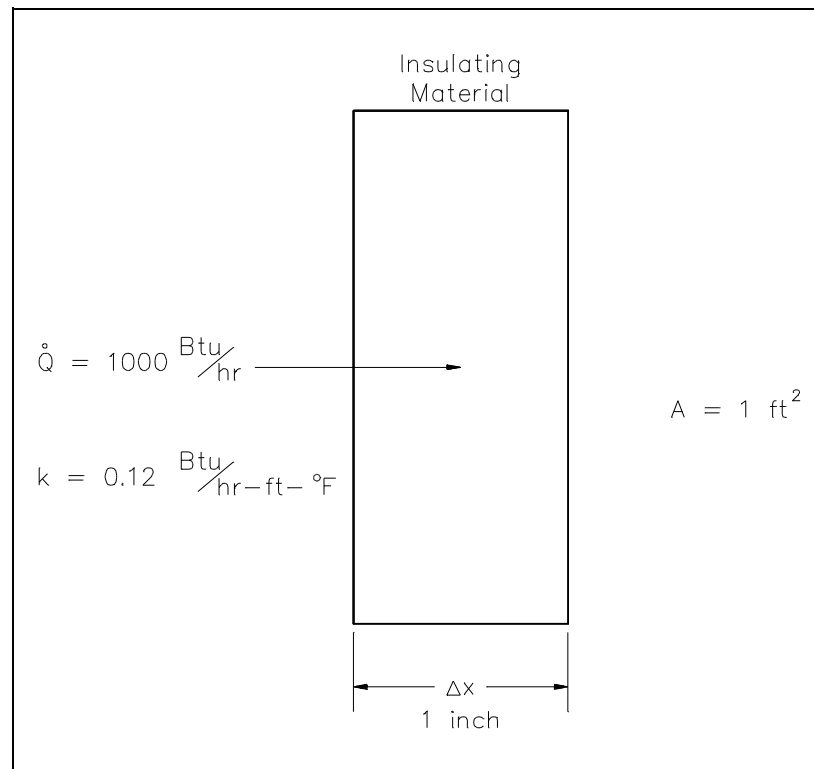

Figure 1 Conduction Through a Slab

Solution:

Using Equation 2-4:

$$\dot{Q} = k A \left(\frac{\Delta T}{\Delta x} \right)$$

Solving for ΔT :

$$\begin{aligned} \Delta T &= \dot{Q} \left(\frac{\Delta x}{k A} \right) \\ &= \frac{\left(1000 \frac{\text{Btu}}{\text{hr}} \right) \left(\frac{1}{12} \text{ ft} \right)}{\left(0.12 \frac{\text{Btu}}{\text{hr-ft-}^\circ\text{F}} \right) (1 \text{ ft}^2)} \end{aligned}$$

$$\Delta T = 694^\circ\text{F}$$

Example:

A concrete floor with a conductivity of 0.8 Btu/hr-ft-°F measures 30 ft by 40 ft with a thickness of 4 inches. The floor has a surface temperature of 70°F and the temperature beneath it is 60°F. What is the heat flux and the heat transfer rate through the floor?

Solution:

Using Equations 2-1 and 2-4:

$$\begin{aligned} \dot{Q}'' &= \frac{\dot{Q}}{A} = k \left(\frac{\Delta T}{\Delta x} \right) \\ &= \left(0.8 \frac{\text{Btu}}{\text{hr-ft-}^\circ\text{F}} \right) \left(\frac{10^\circ\text{F}}{0.333 \text{ ft}} \right) \\ &= 24 \frac{\text{Btu}}{\text{hr-ft}^2} \end{aligned}$$

Using Equation 2-3:

$$\begin{aligned}\dot{Q} &= k A \left(\frac{\Delta T}{\Delta x} \right) = \dot{Q}'' A \\ &= \left(24 \frac{\text{Btu}}{\text{hr-ft}^2} \right) (1200 \text{ ft}^2) \\ &= 28,800 \frac{\text{Btu}}{\text{hr}}\end{aligned}$$

Equivalent Resistance Method

It is possible to compare heat transfer to current flow in electrical circuits. The heat transfer rate may be considered as a current flow and the combination of thermal conductivity, thickness of material, and area as a resistance to this flow. The temperature difference is the potential or driving function for the heat flow, resulting in the Fourier equation being written in a form similar to Ohm's Law of Electrical Circuit Theory. If the thermal resistance term $\Delta x/k$ is written as a resistance term where the resistance is the reciprocal of the thermal conductivity divided by the thickness of the material, the result is the conduction equation being analogous to electrical systems or networks. The electrical analogy may be used to solve complex problems involving both series and parallel thermal resistances. The student is referred to Figure 2, showing the equivalent resistance circuit. A typical conduction problem in its analogous electrical form is given in the following example, where the "electrical" Fourier equation may be written as follows.

$$\dot{Q}'' = \frac{\Delta T}{R_{th}} \quad (2-6)$$

where:

$$\dot{Q}'' = \text{Heat Flux } (\dot{Q}/A) \text{ (Btu/hr-ft}^2\text{)}$$

$$\Delta T = \text{Temperature Difference } (^{\circ}\text{F})$$

$$R_{th} = \text{Thermal Resistance } (\Delta x/k) \text{ (hr-ft}^2\text{-}^{\circ}\text{F/Btu)}$$

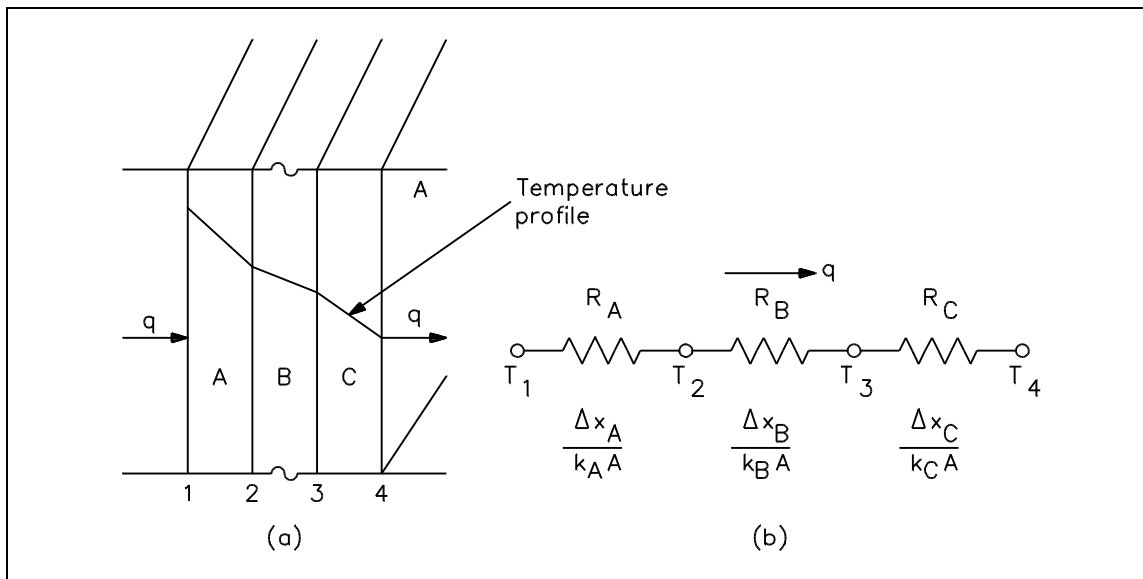

Figure 2 Equivalent Resistance

Electrical Analogy

Example:

A composite protective wall is formed of a 1 in. copper plate, a 1/8 in. layer of asbestos, and a 2 in. layer of fiberglass. The thermal conductivities of the materials in units of Btu/hr-ft-°F are as follows: $k_{\text{Cu}} = 240$, $k_{\text{asb}} = 0.048$, and $k_{\text{fib}} = 0.022$. The overall temperature difference across the wall is 500°F. Calculate the thermal resistance of each layer of the wall and the heat transfer rate per unit area (heat flux) through the composite structure.

Solution:

$$\begin{aligned}
 R_{\text{Cu}} &= \frac{\Delta x_{\text{Cu}}}{k_{\text{Cu}}} & R_{\text{asb}} &= \frac{\Delta x_{\text{asb}}}{k_{\text{asb}}} & R_{\text{fib}} &= \frac{\Delta x_{\text{fib}}}{k_{\text{fib}}} \\
 &= \frac{1 \text{ in} \left(\frac{1 \text{ ft}}{12 \text{ in}} \right)}{240 \frac{\text{Btu}}{\text{hr-ft-}^\circ\text{F}}} & &= \frac{0.125 \text{ in} \left(\frac{1 \text{ ft}}{12 \text{ in}} \right)}{0.048 \frac{\text{Btu}}{\text{hr-ft-}^\circ\text{F}}} & &= \frac{2 \text{ in} \left(\frac{1 \text{ ft}}{12 \text{ in}} \right)}{0.022 \frac{\text{Btu}}{\text{hr-ft-}^\circ\text{F}}} \\
 &= 0.000347 \frac{\text{hr-ft}^2\text{-}^\circ\text{F}}{\text{Btu}} & &= 0.2170 \frac{\text{hr-ft}^2\text{-}^\circ\text{F}}{\text{Btu}} & &= 7.5758 \frac{\text{hr-ft}^2\text{-}^\circ\text{F}}{\text{Btu}}
 \end{aligned}$$

$$\begin{aligned} \frac{\dot{Q}}{A} &= \frac{(T_i - T_o)}{(R_{Cu} + R_{asb} + R_{fib})} \\ &= \frac{500^\circ\text{F}}{(0.000347 + 0.2170 + 7.5758) \frac{\text{hr}\cdot\text{ft}^2\cdot^\circ\text{F}}{\text{Btu}}} \\ &= 64.2 \frac{\text{Btu}}{\text{hr}\cdot\text{ft}^2} \end{aligned}$$

Conduction-Cylindrical Coordinates

Heat transfer across a rectangular solid is the most direct application of Fourier's law. Heat transfer across a pipe or heat exchanger tube wall is more complicated to evaluate. Across a cylindrical wall, the heat transfer surface area is continually increasing or decreasing. Figure 3 is a cross-sectional view of a pipe constructed of a homogeneous material.

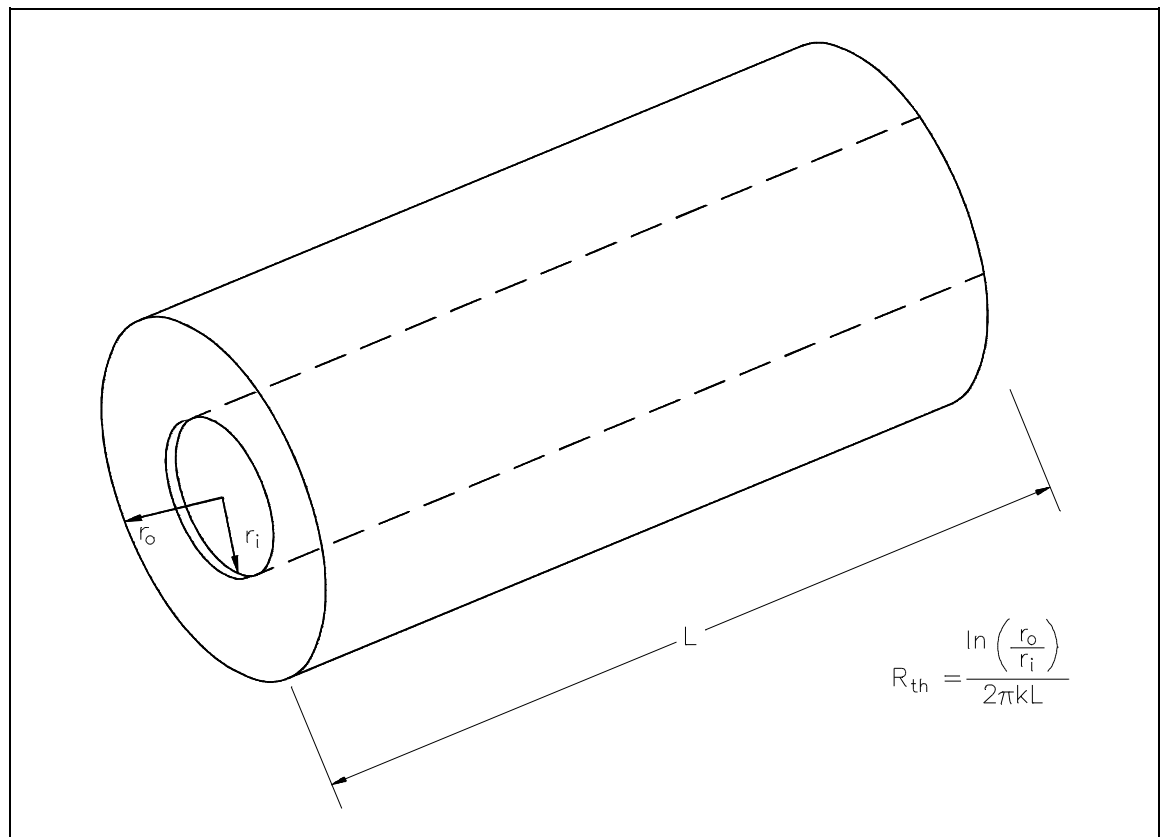

Figure 3 Cross-sectional Surface Area of a Cylindrical Pipe

The surface area (A) for transferring heat through the pipe (neglecting the pipe ends) is directly proportional to the radius (r) of the pipe and the length (L) of the pipe.

$$A = 2\pi rL$$

As the radius increases from the inner wall to the outer wall, the heat transfer area increases.

The development of an equation evaluating heat transfer through an object with cylindrical geometry begins with Fourier's law Equation 2-5.

$$\dot{Q} = k A \left(\frac{\Delta T}{\Delta r} \right)$$

From the discussion above, it is seen that no simple expression for area is accurate. Neither the area of the inner surface nor the area of the outer surface alone can be used in the equation. For a problem involving cylindrical geometry, it is necessary to define a log mean cross-sectional area (A_{lm}).

$$A_{lm} = \frac{A_{outer} - A_{inner}}{\ln \left(\frac{A_{outer}}{A_{inner}} \right)} \quad (2-7)$$

Substituting the expression $2\pi rL$ for area in Equation 2-7 allows the log mean area to be calculated from the inner and outer radius without first calculating the inner and outer area.

$$\begin{aligned} A_{lm} &= \frac{2\pi r_{outer} L - 2\pi r_{inner} L}{\ln \left(\frac{2\pi r_{outer} L}{2\pi r_{inner} L} \right)} \\ &= 2\pi L \left(\frac{r_{outer} - r_{inner}}{\ln \frac{r_{outer}}{r_{inner}}} \right) \end{aligned}$$

This expression for log mean area can be inserted into Equation 2-5, allowing us to calculate the heat transfer rate for cylindrical geometries.

$$\begin{aligned}\dot{Q} &= k A_{lm} \left(\frac{\Delta T}{\Delta r} \right) \\ &= k \left[2 \pi L \left(\frac{r_o - r_i}{\ln \frac{r_o}{r_i}} \right) \right] \left(\frac{T_o - T_i}{r_o - r_i} \right) \\ \dot{Q} &= \frac{2 \pi k L (\Delta T)}{\ln(r_o/r_i)}\end{aligned}\quad (2-8)$$

where:

L = length of pipe (ft)

r_i = inside pipe radius (ft)

r_o = outside pipe radius (ft)

Example:

A stainless steel pipe with a length of 35 ft has an inner diameter of 0.92 ft and an outer diameter of 1.08 ft. The temperature of the inner surface of the pipe is 122°F and the temperature of the outer surface is 118°F. The thermal conductivity of the stainless steel is 108 Btu/hr-ft-°F.

Calculate the heat transfer rate through the pipe.

Calculate the heat flux at the outer surface of the pipe.

Solution:

$$\begin{aligned}\dot{Q} &= \frac{2 \pi k L (T_h - T_c)}{\ln(r_o/r_i)} \\ &= \frac{6.28 \left(108 \frac{\text{Btu}}{\text{hr-ft-}^\circ\text{F}} \right) (35 \text{ ft}) (122^\circ\text{F} - 118^\circ\text{F})}{\ln \frac{0.54 \text{ ft}}{0.46 \text{ ft}}} \\ &= 5.92 \times 10^5 \frac{\text{Btu}}{\text{hr}}\end{aligned}$$

$$\begin{aligned}
 \dot{Q}'' &= \frac{\dot{Q}}{A} \\
 &= \frac{\dot{Q}}{2 \pi r_o L} \\
 &= \frac{5.92 \times 10^5 \frac{\text{Btu}}{\text{hr}}}{2 (3.14) (0.54 \text{ ft}) (35 \text{ ft})} \\
 &= 4985 \frac{\text{Btu}}{\text{hr-ft}^2}
 \end{aligned}$$

Example:

A 10 ft length of pipe with an inner radius of 1 in and an outer radius of 1.25 in has an outer surface temperature of 250°F. The heat transfer rate is 30,000 Btu/hr. Find the interior surface temperature. Assume $k = 25 \text{ Btu/hr-ft-}^\circ\text{F}$.

Solution:

$$\dot{Q} = \frac{2 \pi k L (T_h - T_c)}{\ln(r_o/r_i)}$$

Solving for T_h :

$$\begin{aligned}
 T_h &= \frac{\dot{Q} \ln(r_o/r_i)}{2 \pi k L} + T_c \\
 &= \frac{\left(30,000 \frac{\text{Btu}}{\text{hr}}\right) \left(\ln \frac{1.25 \text{ in}}{1 \text{ in}}\right)}{2 (3.14) \left(25 \frac{\text{Btu}}{\text{hr-ft-}^\circ\text{F}}\right) (10 \text{ ft})} + 250^\circ\text{F} \\
 &= 254^\circ\text{F}
 \end{aligned}$$

The evaluation of heat transfer through a cylindrical wall can be extended to include a composite body composed of several concentric, cylindrical layers, as shown in Figure 4.

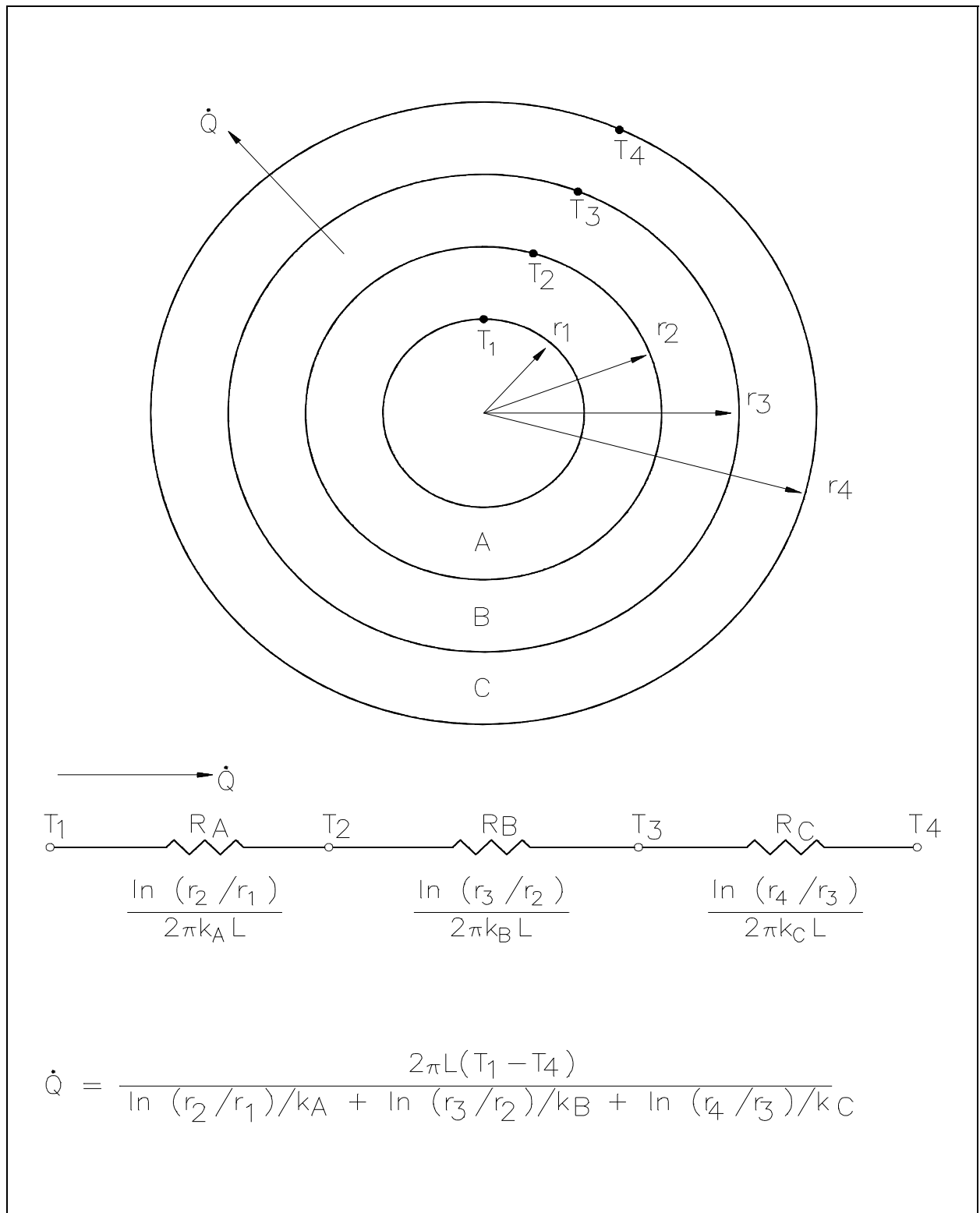

Figure 4 Composite Cylindrical Layers

Example:

A thick-walled nuclear coolant pipe ($k_s = 12.5$ Btu/hr-ft-°F) with 10 in. inside diameter (ID) and 12 in. outside diameter (OD) is covered with a 3 in. layer of asbestos insulation ($k_a = 0.14$ Btu/hr-ft-°F) as shown in Figure 5. If the inside wall temperature of the pipe is maintained at 550°F, calculate the heat loss per foot of length. The outside temperature is 100°F.

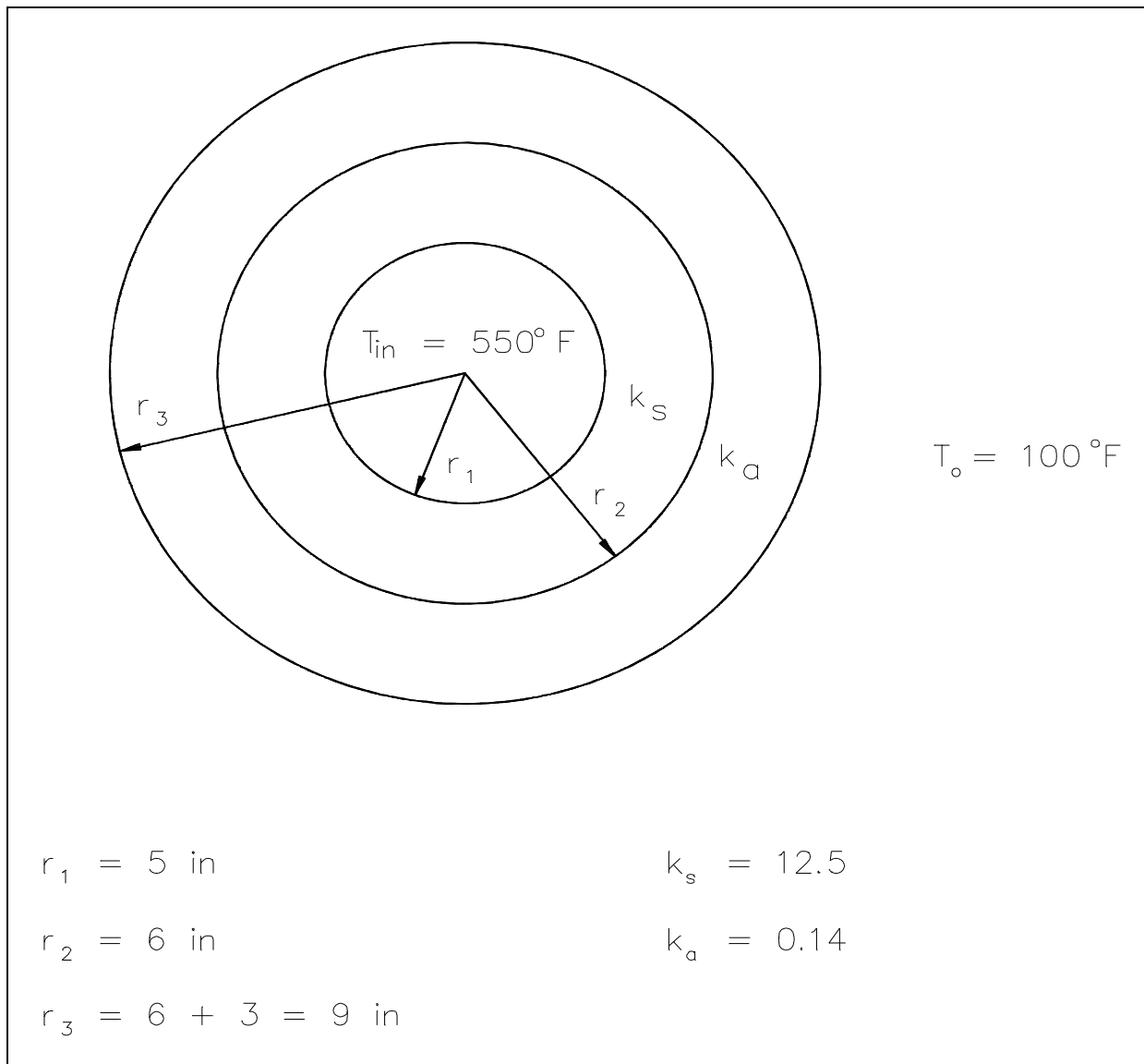

Figure 5 Pipe Insulation Problem

Solution:

$$\begin{aligned} \frac{\dot{Q}}{L} &= \frac{2\pi (T_{in} - T_o)}{\left[\frac{\ln\left(\frac{r_2}{r_1}\right)}{k_s} + \frac{\ln\left(\frac{r_3}{r_2}\right)}{k_a} \right]} \\ &= \frac{2\pi (550^\circ\text{F} - 100^\circ\text{F})}{\left[\frac{\ln\left(\frac{6 \text{ in}}{5 \text{ in}}\right)}{12.5 \frac{\text{Btu}}{\text{hr-ft-}^\circ\text{F}}} + \frac{\ln\left(\frac{9 \text{ in}}{6 \text{ in}}\right)}{0.14 \frac{\text{Btu}}{\text{hr-ft-}^\circ\text{F}}} \right]} \\ &= 971 \frac{\text{Btu}}{\text{hr-ft}} \end{aligned}$$

Summary

The important information in this chapter is summarized below.

Conduction Heat Transfer Summary

- Conduction heat transfer is the transfer of thermal energy by interactions between adjacent molecules of a material.
- Fourier's Law of Conduction can be used to solve for rectangular and cylindrical coordinate problems.
- Heat flux (\dot{Q}'') is the heat transfer rate (\dot{Q}) divided by the area (A).
- Heat conductance problems can be solved using equivalent resistance formulas analogous to electrical circuit problems.

CONVECTION HEAT TRANSFER

Heat transfer by the motion and mixing of the molecules of a liquid or gas is called convection.

EO 1.9 **Given the formula for heat transfer and the operating conditions of the system, CALCULATE the rate of heat transfer by convection.**

Convection

Convection involves the transfer of heat by the motion and mixing of "macroscopic" portions of a fluid (that is, the flow of a fluid past a solid boundary). The term natural convection is used if this motion and mixing is caused by density variations resulting from temperature differences within the fluid. The term forced convection is used if this motion and mixing is caused by an outside force, such as a pump. The transfer of heat from a hot water radiator to a room is an example of heat transfer by natural convection. The transfer of heat from the surface of a heat exchanger to the bulk of a fluid being pumped through the heat exchanger is an example of forced convection.

Heat transfer by convection is more difficult to analyze than heat transfer by conduction because no single property of the heat transfer medium, such as thermal conductivity, can be defined to describe the mechanism. Heat transfer by convection varies from situation to situation (upon the fluid flow conditions), and it is frequently coupled with the mode of fluid flow. In practice, analysis of heat transfer by convection is treated empirically (by direct observation).

Convection heat transfer is treated empirically because of the factors that affect the stagnant film thickness:

- Fluid velocity
- Fluid viscosity
- Heat flux
- Surface roughness
- Type of flow (single-phase/two-phase)

Convection involves the transfer of heat between a surface at a given temperature (T_s) and fluid at a bulk temperature (T_b). The exact definition of the bulk temperature (T_b) varies depending on the details of the situation. For flow adjacent to a hot or cold surface, T_b is the temperature of the fluid "far" from the surface. For boiling or condensation, T_b is the saturation temperature of the fluid. For flow in a pipe, T_b is the average temperature measured at a particular cross-section of the pipe.

The basic relationship for heat transfer by convection has the same form as that for heat transfer by conduction:

$$\dot{Q} = h A \Delta T \quad (2-9)$$

where:

$$\dot{Q} = \text{rate of heat transfer (Btu/hr)}$$

$$h = \text{convective heat transfer coefficient (Btu/hr-ft}^2\text{-}^\circ\text{F)}$$

$$A = \text{surface area for heat transfer (ft}^2\text{)}$$

$$\Delta T = \text{temperature difference (}^\circ\text{F)}$$

The convective heat transfer coefficient (h) is dependent upon the physical properties of the fluid and the physical situation. Typically, the convective heat transfer coefficient for laminar flow is relatively low compared to the convective heat transfer coefficient for turbulent flow. This is due to turbulent flow having a thinner stagnant fluid film layer on the heat transfer surface. Values of h have been measured and tabulated for the commonly encountered fluids and flow situations occurring during heat transfer by convection.

Example:

A 22 foot uninsulated steam line crosses a room. The outer diameter of the steam line is 18 in. and the outer surface temperature is 280°F. The convective heat transfer coefficient for the air is 18 Btu/hr-ft²-°F. Calculate the heat transfer rate from the pipe into the room if the room temperature is 72°F.

Solution:

$$\begin{aligned} \dot{Q} &= h A \Delta T \\ &= h (2 \pi r L) \Delta T \\ &= \left(18 \frac{\text{Btu}}{\text{hr-ft}^2\text{-}^\circ\text{F}} \right) (2 (3.14) (0.75 \text{ ft}) (22 \text{ ft})) (280^\circ\text{F} - 72^\circ\text{F}) \\ &= 3.88 \times 10^5 \frac{\text{Btu}}{\text{hr}} \end{aligned}$$

Many applications involving convective heat transfer take place within pipes, tubes, or some similar cylindrical device. In such circumstances, the surface area of heat transfer normally given in the convection equation ($\dot{Q} = h A \Delta T$) varies as heat passes through the cylinder. In addition, the temperature difference existing between the inside and the outside of the pipe, as well as the temperature differences along the pipe, necessitates the use of some average temperature value in order to analyze the problem. This average temperature difference is called the log mean temperature difference (LMTD), described earlier.

It is the temperature difference at one end of the heat exchanger minus the temperature difference at the other end of the heat exchanger, divided by the natural logarithm of the ratio of these two temperature differences. The above definition for LMTD involves two important assumptions: (1) the fluid specific heats do not vary significantly with temperature, and (2) the convection heat transfer coefficients are relatively constant throughout the heat exchanger.

Overall Heat Transfer Coefficient

Many of the heat transfer processes encountered in nuclear facilities involve a combination of both conduction and convection. For example, heat transfer in a steam generator involves convection from the bulk of the reactor coolant to the steam generator inner tube surface, conduction through the tube wall, and convection from the outer tube surface to the secondary side fluid.

In cases of combined heat transfer for a heat exchanger, there are two values for h . There is the convective heat transfer coefficient (h) for the fluid film inside the tubes and a convective heat transfer coefficient for the fluid film outside the tubes. The thermal conductivity (k) and thickness (Δx) of the tube wall must also be accounted for. An additional term (U_o), called the overall heat transfer coefficient, must be used instead. It is common practice to relate the total rate of heat transfer (\dot{Q}) to the cross-sectional area for heat transfer (A_o) and the overall heat transfer coefficient (U_o). The relationship of the overall heat transfer coefficient to the individual conduction and convection terms is shown in Figure 6.

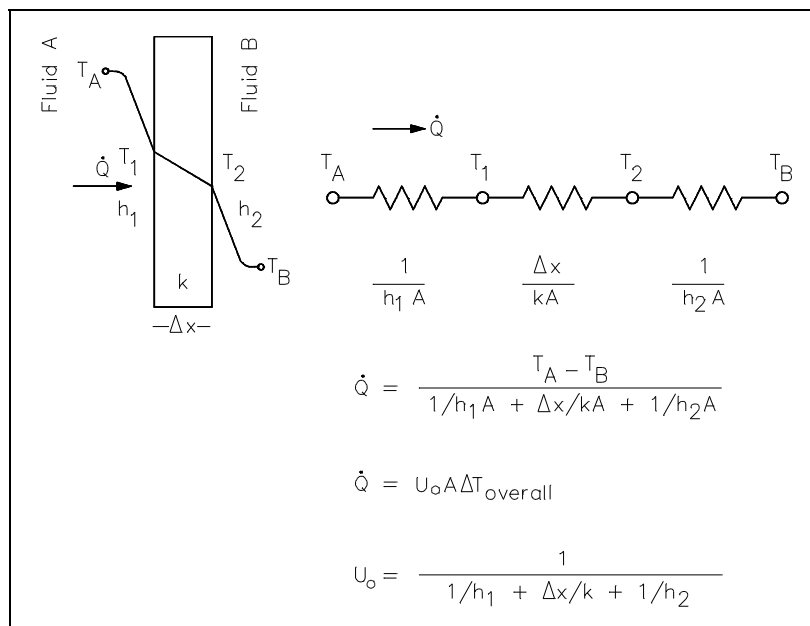

Figure 6 Overall Heat Transfer Coefficient

Recalling Equation 2-3:

$$\dot{Q} = U_o A_o \Delta T_o$$

where U_o is defined in Figure 6.

An example of this concept applied to cylindrical geometry is illustrated by Figure 7, which shows a typical combined heat transfer situation.

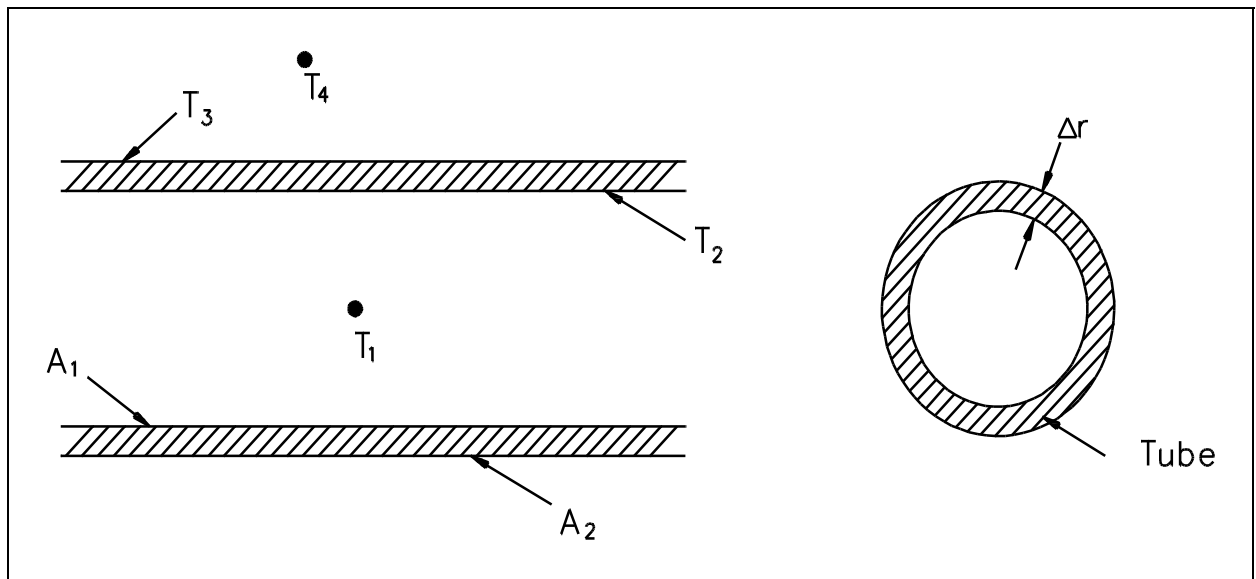

Figure 7 Combined Heat Transfer

Using the figure representing flow in a pipe, heat transfer by convection occurs between temperatures T_1 and T_2 ; heat transfer by conduction occurs between temperatures T_2 and T_3 ; and heat transfer occurs by convection between temperatures T_3 and T_4 . Thus, there are three processes involved. Each has an associated heat transfer coefficient, cross-sectional area for heat transfer, and temperature difference. The basic relationships for these three processes can be expressed using Equations 2-5 and 2-9.

$$\dot{Q} = h_1 A_1 (T_1 - T_2)$$

$$\dot{Q} = \frac{k}{\Delta r} A_{lm} (T_2 - T_3)$$

$$\dot{Q} = h_2 A_2 (T_3 - T_4)$$

ΔT_o can be expressed as the sum of the ΔT of the three individual processes.

$$\Delta T_o = (T_1 - T_2) + (T_2 - T_3) + (T_3 - T_4)$$

If the basic relationship for each process is solved for its associated temperature difference and substituted into the expression for ΔT_o above, the following relationship results.

$$\Delta T_o = \dot{Q} \left(\frac{1}{h_1 A_1} + \frac{\Delta r}{k A_{lm}} + \frac{1}{h_2 A_2} \right)$$

This relationship can be modified by selecting a reference cross-sectional area A_o .

$$\Delta T_o = \frac{\dot{Q}}{A_o} \left(\frac{A_o}{h_1 A_1} + \frac{\Delta r A_o}{k A_{lm}} + \frac{A_o}{h_2 A_2} \right)$$

Solving for \dot{Q} results in an equation in the form $\dot{Q} = U_o A_o \Delta T_o$.

$$\dot{Q} = \frac{1}{\left(\frac{A_o}{h_1 A_1} + \frac{\Delta r A_o}{k A_{lm}} + \frac{A_o}{h_2 A_2} \right)} A_o \Delta T_o$$

where:

$$U_o = \frac{1}{\left(\frac{A_o}{h_1 A_1} + \frac{\Delta r A_o}{k A_{lm}} + \frac{A_o}{h_2 A_2} \right)} \quad (2-10)$$

Equation 2-10 for the overall heat transfer coefficient in cylindrical geometry is relatively difficult to work with. The equation can be simplified without losing much accuracy if the tube that is being analyzed is thin-walled, that is the tube wall thickness is small compared to the tube diameter. For a thin-walled tube, the inner surface area (A_1), outer surface area (A_2), and log mean surface area (A_{lm}), are all very close to being equal. Assuming that A_1 , A_2 , and A_{lm} are equal to each other and also equal to A_o allows us to cancel out all the area terms in the denominator of Equation 2-11.

This results in a much simpler expression that is similar to the one developed for a flat plate heat exchanger in Figure 6.

$$U_o = \frac{1}{\frac{1}{h_1} + \frac{\Delta r}{k} + \frac{1}{h_2}} \quad (2-11)$$

The convection heat transfer process is strongly dependent upon the properties of the fluid being considered. Correspondingly, the convective heat transfer coefficient (h), the overall coefficient (U_o), and the other fluid properties may vary substantially for the fluid if it experiences a large temperature change during its path through the convective heat transfer device. This is especially true if the fluid's properties are strongly temperature dependent. Under such circumstances, the temperature at which the properties are "looked-up" must be some type of average value, rather than using either the inlet or outlet temperature value.

For internal flow, the bulk or average value of temperature is obtained analytically through the use of conservation of energy. For external flow, an average film temperature is normally calculated, which is an average of the free stream temperature and the solid surface temperature. In any case, an average value of temperature is used to obtain the fluid properties to be used in the heat transfer problem. The following example shows the use of such principles by solving a convective heat transfer problem in which the bulk temperature is calculated.

Convection Heat Transfer

Example:

A flat wall is exposed to the environment. The wall is covered with a layer of insulation 1 in. thick whose thermal conductivity is 0.8 Btu/hr-ft-°F. The temperature of the wall on the inside of the insulation is 600°F. The wall loses heat to the environment by convection on the surface of the insulation. The average value of the convection heat transfer coefficient on the insulation surface is 950 Btu/hr-ft²-°F. Compute the bulk temperature of the environment (T_b) if the outer surface of the insulation does not exceed 105°F.

Solution:

- a. Find heat flux (\dot{Q}'') through the insulation.

$$\dot{Q} = k A \left(\frac{\Delta T}{\Delta x} \right)$$

$$\frac{\dot{Q}}{A} = 0.8 \frac{\text{Btu}}{\text{hr-ft-}^\circ\text{F}} \left(\frac{600^\circ\text{F} - 105^\circ\text{F}}{1 \text{ in } \frac{1 \text{ ft}}{12 \text{ in}}} \right)$$

$$= 4752 \frac{\text{Btu}}{\text{hr-ft}^2}$$

- b. Find the bulk temperature of the environment.

$$\dot{Q} = h A (T_{\text{ins}} - T_{\text{b}})$$

$$(T_{\text{ins}} - T_{\text{b}}) = \frac{\dot{Q}}{h A}$$

$$T_{\text{b}} = T_{\text{ins}} - \frac{\dot{Q}''}{h}$$

$$T_{\text{b}} = 105^\circ\text{F} - \frac{4752 \frac{\text{Btu}}{\text{hr-ft}^2}}{950 \frac{\text{Btu}}{\text{hr-ft}^2-^\circ\text{F}}}$$

$$T_{\text{b}} = 100^\circ\text{F}$$

Summary

The important information in this chapter is summarized below.

Convection Heat Transfer Summary

- Convection heat transfer is the transfer of thermal energy by the mixing and motion of a fluid or gas.
- Whether convection is natural or forced is determined by how the medium is placed into motion.
- When both convection and conduction heat transfer occurs, the overall heat transfer coefficient must be used to solve problems.
- The heat transfer equation for convection heat transfer is $\dot{Q} = hA\Delta T$.

RADIANT HEAT TRANSFER

Radiant heat transfer is thermal energy transferred by means of electromagnetic waves or particles.

- EO 1.10** **DESCRIBE** how the following terms relate to radiant heat transfer:
- a.** **Black body radiation**
 - b.** **Emissivity**
 - c.** **Radiation configuration factor**
-

Thermal Radiation

Radiant heat transfer involves the transfer of heat by electromagnetic radiation that arises due to the temperature of a body. Most energy of this type is in the infra-red region of the electromagnetic spectrum although some of it is in the visible region. The term thermal radiation is frequently used to distinguish this form of electromagnetic radiation from other forms, such as radio waves, x-rays, or gamma rays. The transfer of heat from a fireplace across a room in the line of sight is an example of radiant heat transfer.

Radiant heat transfer does not need a medium, such as air or metal, to take place. Any material that has a temperature above absolute zero gives off some radiant energy. When a cloud covers the sun, both its heat and light diminish. This is one of the most familiar examples of heat transfer by thermal radiation.

Black Body Radiation

A body that emits the maximum amount of heat for its absolute temperature is called a black body. Radiant heat transfer rate from a black body to its surroundings can be expressed by the following equation.

$$\dot{Q} = \sigma AT^4 \quad (2-12)$$

where:

\dot{Q} = heat transfer rate (Btu/hr)

σ = Stefan-Boltzman constant (0.174 Btu/hr-ft²-°R⁴)

A = surface area (ft²)

T = temperature (°R)

Two black bodies that radiate toward each other have a net heat flux between them. The net flow rate of heat between them is given by an adaptation of Equation 2-12.

$$\dot{Q} = \sigma A (T_1^4 - T_2^4)$$

where:

A = surface area of the first body (ft²)

T₁ = temperature of the first body (°R)

T₂ = temperature of the second body (°R)

All bodies above absolute zero temperature radiate some heat. The sun and earth both radiate heat toward each other. This seems to violate the Second Law of Thermodynamics, which states that heat cannot flow from a cold body to a hot body. The paradox is resolved by the fact that each body must be in direct line of sight of the other to receive radiation from it. Therefore, whenever the cool body is radiating heat to the hot body, the hot body must also be radiating heat to the cool body. Since the hot body radiates more heat (due to its higher temperature) than the cold body, the net flow of heat is from hot to cold, and the second law is still satisfied.

Emissivity

Real objects do not radiate as much heat as a perfect black body. They radiate less heat than a black body and are called gray bodies. To take into account the fact that real objects are gray bodies, Equation 2-12 is modified to be of the following form.

$$\dot{Q} = \varepsilon \sigma A T^4$$

where:

ε = emissivity of the gray body (dimensionless)

Emissivity is simply a factor by which we multiply the black body heat transfer to take into account that the black body is the ideal case. Emissivity is a dimensionless number and has a maximum value of 1.0.

Radiation Configuration Factor

Radiative heat transfer rate between two gray bodies can be calculated by the equation stated below.

$$\dot{Q} = f_a f_e \sigma A (T_1^4 - T_2^4)$$

where:

$f_a =$ is the shape factor, which depends on the spatial arrangement of the two objects (dimensionless)

$f_e =$ is the emissivity factor, which depends on the emissivities of both objects (dimensionless)

The two separate terms f_a and f_e can be combined and given the symbol f . The heat flow between two gray bodies can now be determined by the following equation:

$$\dot{Q} = f\sigma A(T_1^4 - T_2^4) \quad (2-13)$$

The symbol (f) is a dimensionless factor sometimes called the *radiation configuration factor*, which takes into account the emissivity of both bodies and their relative geometry. The radiation configuration factor is usually found in a text book for the given situation. Once the configuration factor is obtained, the overall net heat flux can be determined. Radiant heat flux should only be included in a problem when it is greater than 20% of the problem.

Example:

Calculate the radiant heat between the floor (15 ft x 15 ft) of a furnace and the roof, if the two are located 10 ft apart. The floor and roof temperatures are 2000°F and 600°F, respectively. Assume that the floor and the roof have black surfaces.

Solution:

$$A_1 = A_2 = (15 \text{ ft}) (15 \text{ ft}) = 225 \text{ ft}^2$$

$$T_1 = 2000^\circ\text{F} + 460 = 2460^\circ\text{R}$$

$$T_2 = 600^\circ\text{F} + 460 = 1060^\circ\text{R}$$

Tables from a reference book, or supplied by the instructor, give:

$$f_{1-2} = f_{2-1} = 0.31$$

$$Q_{1-2} = \sigma A f (T_1^4 - T_2^4)$$

$$= (0.174 \frac{\text{Btu}}{\text{hr-ft}^2-\text{R}^4}) (225 \text{ ft}^2) (0.31) [(2460^\circ\text{R})^4 - (1060^\circ\text{R})^4]$$

$$= 4.29 \times 10^{14} \text{ Btu/hr}$$

Summary

The important information in this chapter is summarized below.

Radiant Heat Transfer Summary

- Black body radiation is the maximum amount of heat that can be transferred from an ideal object.
- Emissivity is a measure of the departure of a body from the ideal black body.
- Radiation configuration factor takes into account the emittance and relative geometry of two objects.

HEAT EXCHANGERS

Heat exchangers are devices that are used to transfer thermal energy from one fluid to another without mixing the two fluids.

- EO 1.11** **DESCRIBE** the difference in the temperature profiles for counter-flow and parallel flow heat exchangers.
- EO 1.12** **DESCRIBE** the differences between regenerative and non-regenerative heat exchangers.
- EO 1.13** **Given** the temperature changes across a heat exchanger, **CALCULATE** the log mean temperature difference for the heat exchanger.
- EO 1.14** **Given** the formulas for calculating the conduction and convection heat transfer coefficients, **CALCULATE** the overall heat transfer coefficient of a system.

Heat Exchangers

The transfer of thermal energy between fluids is one of the most important and frequently used processes in engineering. The transfer of heat is usually accomplished by means of a device known as a heat exchanger. Common applications of heat exchangers in the nuclear field include boilers, fan coolers, cooling water heat exchangers, and condensers.

The basic design of a heat exchanger normally has two fluids of different temperatures separated by some conducting medium. The most common design has one fluid flowing through metal tubes and the other fluid flowing around the tubes. On either side of the tube, heat is transferred by convection. Heat is transferred through the tube wall by conduction.

Heat exchangers may be divided into several categories or classifications. In the most commonly used type of heat exchanger, two fluids of different temperature flow in spaces separated by a tube wall. They transfer heat by convection and by conduction through the wall. This type is referred to as an "ordinary heat exchanger," as compared to the other two types classified as "regenerators" and "cooling towers."

An ordinary heat exchanger is single-phase or two-phase. In a single-phase heat exchanger, both of the fluids (cooled and heated) remain in their initial gaseous or liquid states. In two-phase exchangers, either of the fluids may change its phase during the heat exchange process. The steam generator and main condenser of nuclear facilities are of the two-phase, ordinary heat exchanger classification.

Single-phase heat exchangers are usually of the tube-and-shell type; that is, the exchanger consists of a set of tubes in a container called a shell (Figure 8). At the ends of the heat exchanger, the tube-side fluid is separated from the shell-side fluid by a tube sheet. The design of two-phase exchangers is essentially the same as that of single-phase exchangers.

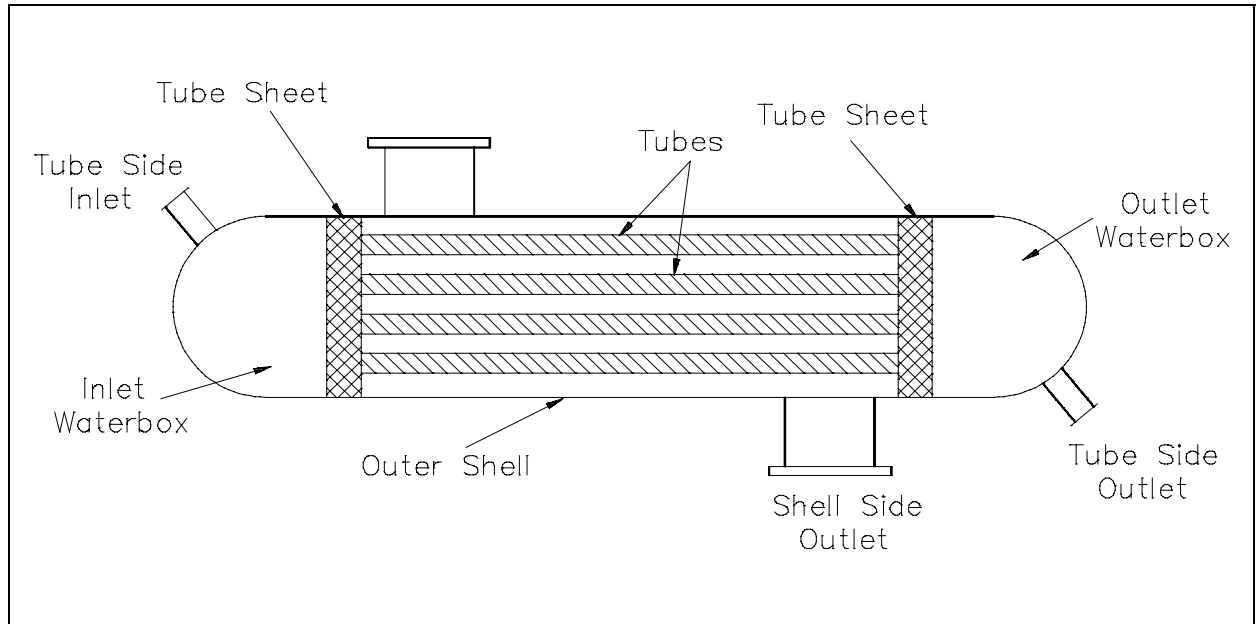

Figure 8 Typical Tube and Shell Heat Exchanger

Parallel and Counter-Flow Designs

Although ordinary heat exchangers may be extremely different in design and construction and may be of the single- or two-phase type, their modes of operation and effectiveness are largely determined by the direction of the fluid flow within the exchanger.

The most common arrangements for flow paths within a heat exchanger are counter-flow and parallel flow. A counter-flow heat exchanger is one in which the direction of the flow of one of the working fluids is opposite to the direction of the flow of the other fluid. In a parallel flow exchanger, both fluids in the heat exchanger flow in the same direction.

Figure 9 represents the directions of fluid flow in the parallel and counter-flow exchangers. Under comparable conditions, more heat is transferred in a counter-flow arrangement than in a parallel flow heat exchanger.

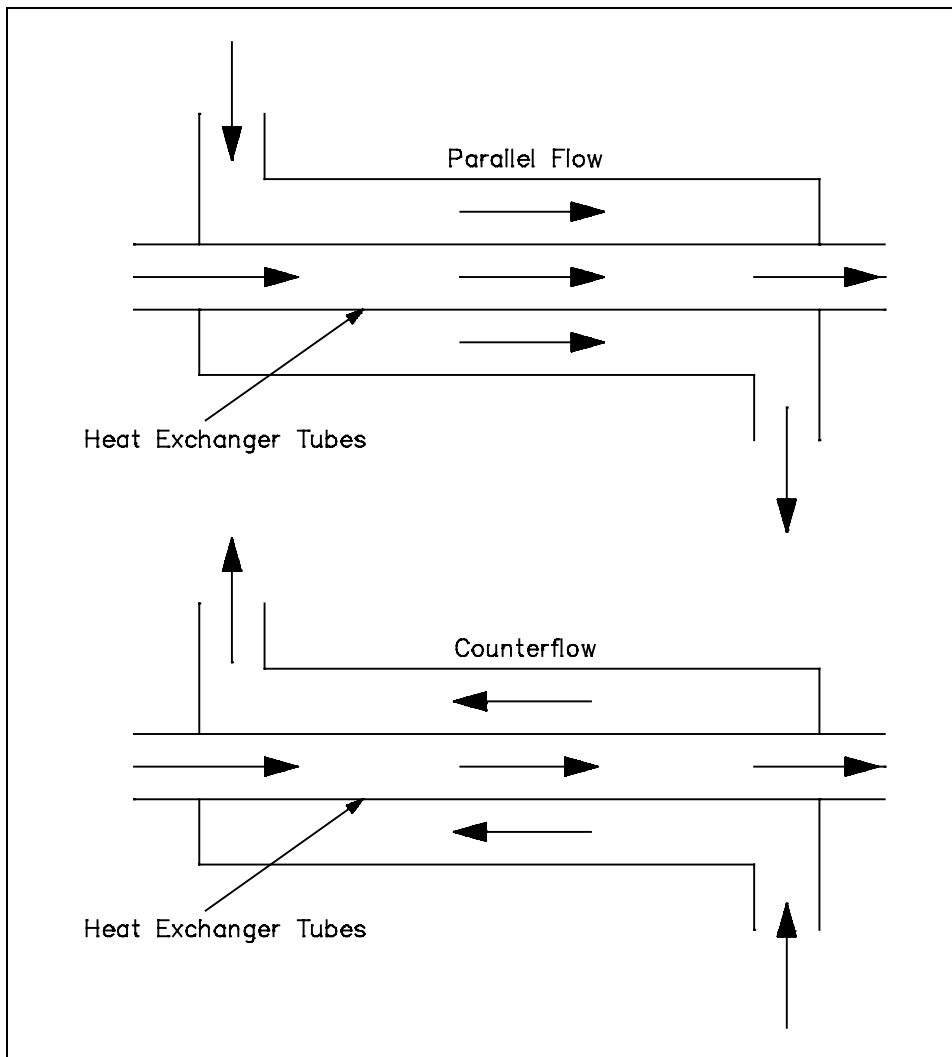

Figure 9 Fluid Flow Direction

The temperature profiles of the two heat exchangers indicate two major disadvantages in the parallel-flow design. First, the large temperature difference at the ends (Figure 10) causes large thermal stresses. The opposing expansion and contraction of the construction materials due to diverse fluid temperatures can lead to eventual material failure. Second, the temperature of the cold fluid exiting the heat exchanger never exceeds the lowest temperature of the hot fluid. This relationship is a distinct disadvantage if the design purpose is to raise the temperature of the cold fluid.

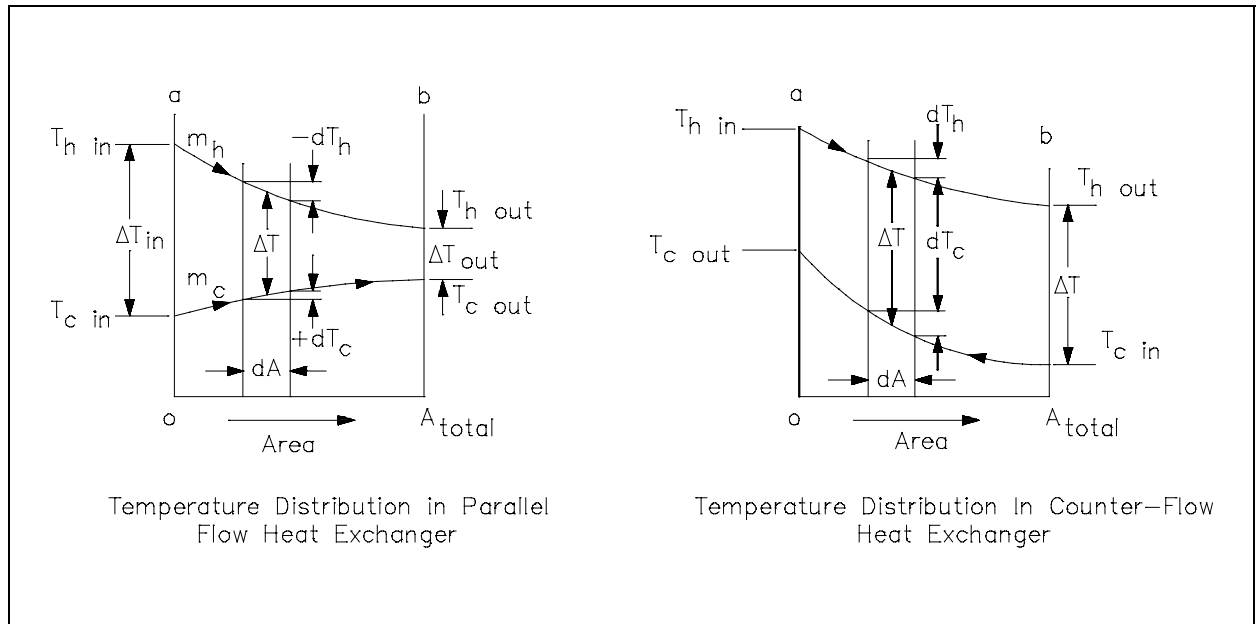

Figure 10 Heat Exchanger Temperature Profiles

The design of a parallel flow heat exchanger is advantageous when two fluids are required to be brought to nearly the same temperature.

The counter-flow heat exchanger has three significant advantages over the parallel flow design. First, the more uniform temperature difference between the two fluids minimizes the thermal stresses throughout the exchanger. Second, the outlet temperature of the cold fluid can approach the highest temperature of the hot fluid (the inlet temperature). Third, the more uniform temperature difference produces a more uniform rate of heat transfer throughout the heat exchanger.

Whether parallel or counter-flow, heat transfer within the heat exchanger involves both conduction and convection. One fluid (hot) convectively transfers heat to the tube wall where conduction takes place across the tube to the opposite wall. The heat is then convectively transferred to the second fluid. Because this process takes place over the entire length of the exchanger, the temperature of the fluids as they flow through the exchanger is not generally constant, but varies over the entire length, as indicated in Figure 10. The rate of heat transfer varies along the length of the exchanger tubes because its value depends upon the temperature difference between the hot and the cold fluid at the point being viewed.

Non-Regenerative Heat Exchanger

Applications of heat exchangers may be classified as either regenerative or non-regenerative. The non-regenerative application is the most frequent and involves two separate fluids. One fluid cools or heats the other with no interconnection between the two fluids. Heat that is removed from the hotter fluid is usually rejected to the environment or some other heat sink (Figure 11).

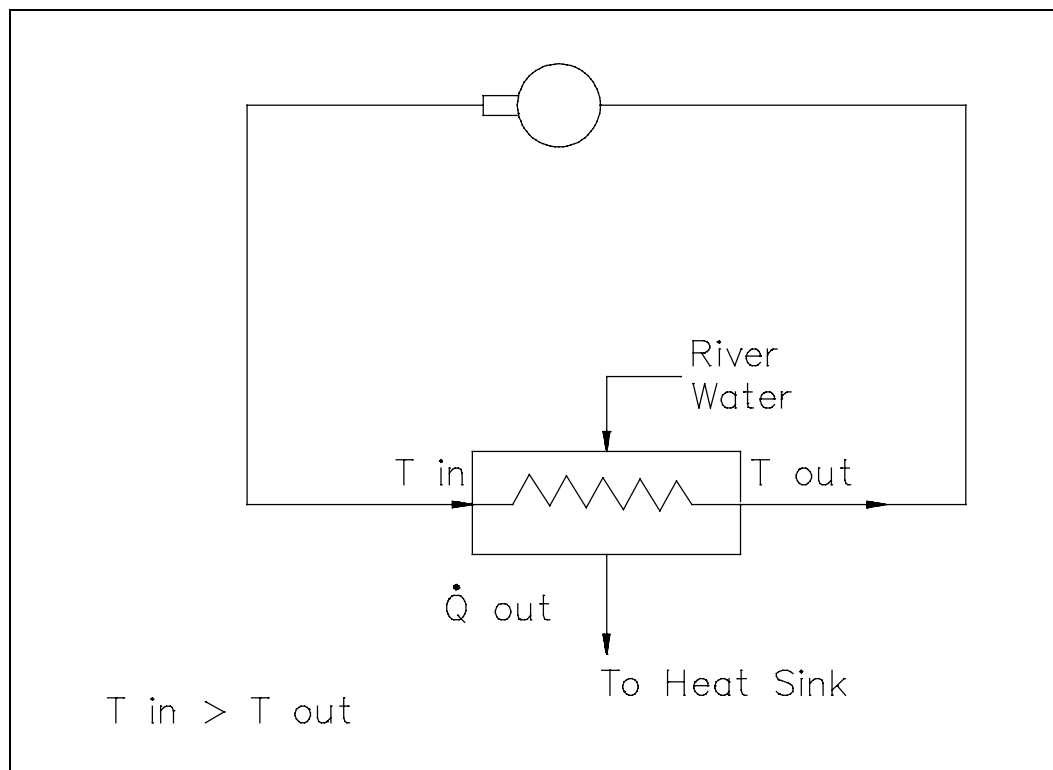

Figure 11 Non-Regenerative Heat Exchanger

Regenerative Heat Exchanger

A regenerative heat exchanger typically uses the fluid from a different area of the same system for both the hot and cold fluids. An example of both regenerative and non-regenerative heat exchangers working in conjunction is commonly found in the purification system of a reactor facility. The primary coolant to be purified is drawn out of the primary system, passed through a regenerative heat exchanger, non-regenerative heat exchanger, demineralizer, back through the regenerative heat exchanger, and returned to the primary system (Figure 12).

In the regenerative heat exchanger, the water returning to the primary system is pre-heated by the water entering the purification system. This accomplishes two objectives. The first is to minimize the thermal stress in the primary system piping due to the cold temperature of the purified coolant being returned to the primary system.

The second is to reduce the temperature of the water entering the purification system prior to reaching the non-regenerative heat exchanger, allowing use of a smaller heat exchanger to achieve the desired temperature for purification. The primary advantage of a regenerative heat exchanger application is conservation of system energy (that is, less loss of system energy due to the cooling of the fluid).

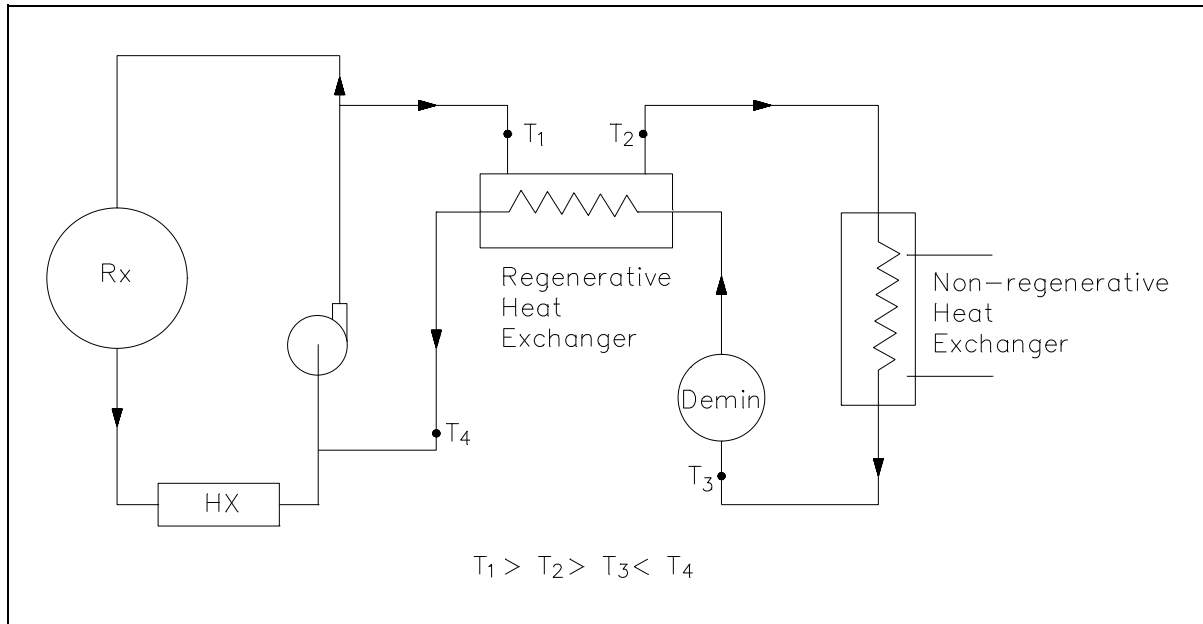

Figure 12 Regenerative Heat Exchanger

Cooling Towers

The typical function of a cooling tower is to cool the water of a steam power plant by air that is brought into direct contact with the water. The water is mixed with vapor that diffuses from the condensate into the air. The formation of the vapor requires a considerable removal of internal energy from the water; the internal energy becomes "latent heat" of the vapor. Heat and mass exchange are coupled in this process, which is a steady-state process like the heat exchange in the ordinary heat exchanger.

Wooden cooling towers are sometimes employed in nuclear facilities and in factories of various industries. They generally consist of large chambers loosely filled with trays or similar wooden elements of construction. The water to be cooled is pumped to the top of the tower where it is distributed by spray or wooden troughs. It then falls through the tower, splashing down from deck to deck. A part of it evaporates into the air that passes through the tower. The enthalpy needed for the evaporation is taken from the water and transferred to the air, which is heated while the water cools. The air flow is either horizontal due to wind currents (cross flow) or vertically upward in counter-flow to the falling water. The counter-flow is caused by the

chimney effect of the warm humid air in the tower or by fans at the bottom (forced draft) or at the top (induced flow) of the tower. Mechanical draft towers are more economical to construct and smaller in size than natural-convection towers of the same cooling capacity.

Log Mean Temperature Difference Application To Heat Exchangers

In order to solve certain heat exchanger problems, a log mean temperature difference (LMTD or ΔT_{lm}) must be evaluated before the heat removal from the heat exchanger is determined. The following example demonstrates such a calculation.

Example:

A liquid-to-liquid counterflow heat exchanger is used as part of an auxiliary system at a nuclear facility. The heat exchanger is used to heat a cold fluid from 120°F to 310°F. Assuming that the hot fluid enters at 500°F and leaves at 400°F, calculate the LMTD for the exchanger.

Solution:

$$\Delta T_2 = 400^\circ\text{F} - 120^\circ\text{F} = 280^\circ\text{F}$$

$$\Delta T_1 = 500^\circ\text{F} - 310^\circ\text{F} = 190^\circ\text{F}$$

$$\begin{aligned} \Delta T_{lm} &= \frac{(\Delta T_2 - \Delta T_1)}{\ln \left(\frac{\Delta T_2}{\Delta T_1} \right)} \\ &= \frac{(280^\circ\text{F} - 190^\circ\text{F})}{\ln \left(\frac{280^\circ\text{F}}{190^\circ\text{F}} \right)} \\ &= 232^\circ\text{F} \end{aligned}$$

The solution to the heat exchanger problem may be simple enough to be represented by a straight-forward overall balance or may be so detailed as to require integral calculus. A steam generator, for example, can be analyzed by an overall energy balance from the feedwater inlet to the steam outlet in which the amount of heat transferred can be expressed simply as $\dot{Q} = \dot{m} \Delta h$, where \dot{m} is the mass flow rate of the secondary coolant and Δh is the change in enthalpy of the fluid. The same steam generator can also be analyzed by an energy balance on the primary flow stream with the equation $\dot{Q} = \dot{m} c_p \Delta T$, where \dot{m} , c_p , and ΔT are the mass flow rate, specific heat capacity, and temperature change of the primary coolant. The heat

transfer rate of the steam generator can also be determined by comparing the temperatures on the primary and secondary sides with the heat transfer characteristics of the steam generator using the equation $\dot{Q} = U_o A_o \Delta T_{lm}$.

Condensers are also examples of components found in nuclear facilities where the concept of LMTD is needed to address certain problems. When the steam enters the condenser, it gives up its latent heat of vaporization to the circulating water and changes phase to a liquid. Because condensation is taking place, it is appropriate to term this the latent heat of condensation. After the steam condenses, the saturated liquid will continue to transfer some heat to the circulating water system as it continues to fall to the bottom (hotwell) of the condenser. This continued cooling is called subcooling and is necessary to prevent cavitation in the condensate pumps.

The solution to condenser problems is approached in the same manner as those for steam generators, as shown in the following example.

Overall Heat Transfer Coefficient

When dealing with heat transfer across heat exchanger tubes, an overall heat transfer coefficient, U_o , must be calculated. Earlier in this module we looked at a method for calculating U_o for both rectangular and cylindrical coordinates. Since the thickness of a condenser tube wall is so small and the cross-sectional area for heat transfer is relatively constant, we can use Equation 2-11 to calculate U_o .

$$U_o = \frac{1}{\frac{1}{h_1} + \frac{\Delta r}{k} + \frac{1}{h_2}}$$

Example:

Referring to the convection section of this manual, calculate the heat rate per foot of tube from a condenser under the following conditions. $\Delta T_{lm} = 232^\circ\text{F}$. The outer diameter of the copper condenser tube is 0.75 in. with a wall thickness of 0.1 in. Assume the inner convective heat transfer coefficient is 2000 Btu/hr-ft²-°F, and the thermal conductivity of copper is 200 Btu/hr-ft-°F. The outer convective heat transfer coefficient is 1500 Btu/hr-ft²-°F.

Solution:

$$\begin{aligned}
 U_o &= \frac{1}{\frac{1}{h_1} + \frac{\Delta r}{k} + \frac{1}{h_2}} \\
 &= \frac{1}{\frac{1}{2000} + \frac{0.1 \text{ in}}{200} \frac{1 \text{ ft}}{12 \text{ in}} + \frac{1}{1500}} \\
 &= 827.6 \frac{\text{Btu}}{\text{hr-ft}^2-\text{°F}}
 \end{aligned}$$

$$\dot{Q} = U_o A_o \Delta T_{lm}$$

$$\frac{\dot{Q}}{L} = \frac{U_o A_o \Delta T_{lm}}{L}$$

$$= U_o 2\pi r \Delta T_{lm}$$

$$= \left(827.6 \frac{\text{Btu}}{\text{hr-ft}^2-\text{°F}} \right) (2\pi) (0.375 \text{ in}) \left(\frac{1 \text{ ft}}{12 \text{ in}} \right) (232\text{°F})$$

$$= 37,700 \frac{\text{Btu}}{\text{hr-ft}}$$

Summary

The important information in this chapter is summarized below.

Heat Exchangers Summary

- Heat exchangers remove heat from a high-temperature fluid by convection and conduction.
- Counter-flow heat exchangers typically remove more heat than parallel flow heat exchangers.
- Parallel flow heat exchangers have a large temperature difference at the inlet and a small temperature difference at the outlet.
- Counter-flow heat exchangers have an even temperature difference across the heat transfer length.
- Regenerative heat exchangers improve system efficiency by returning energy to the system. A non-regenerative heat exchanger rejects heat to the surroundings.
- The heat transfer rate for a heat exchanger can be calculated using the equation below.

$$\dot{Q} = U_o A_o \Delta T_{lm}$$

BOILING HEAT TRANSFER

The formation of steam bubbles along a heat transfer surface has a significant effect on the overall heat transfer rate.

- EO 1.15** **DESCRIBE** the process that occurs in the following regions of the boiling heat transfer curve:
- a. **Nucleate boiling**
 - b. **Partial film boiling**
 - c. **Film boiling**
 - d. **Departure from nucleate boiling (DNB)**
 - e. **Critical heat flux**
-

Boiling

In a nuclear facility, convective heat transfer is used to remove heat from a heat transfer surface. The liquid used for cooling is usually in a compressed state, (that is, a subcooled fluid) at pressures higher than the normal saturation pressure for the given temperature. Under certain conditions, some type of boiling (usually nucleate boiling) can take place. It is advisable, therefore, to study the process of boiling as it applies to the nuclear field when discussing convection heat transfer.

More than one type of boiling can take place within a nuclear facility, especially if there is a rapid loss of coolant pressure. A discussion of the boiling processes, specifically local and bulk boiling, will help the student understand these processes and provide a clearer picture of why bulk boiling (specifically film boiling) is to be avoided in nuclear facility operations.

Nucleate Boiling

The most common type of local boiling encountered in nuclear facilities is nucleate boiling. In nucleate boiling, steam bubbles form at the heat transfer surface and then break away and are carried into the main stream of the fluid. Such movement enhances heat transfer because the heat generated at the surface is carried directly into the fluid stream. Once in the main fluid stream, the bubbles collapse because the bulk temperature of the fluid is not as high as the heat transfer surface temperature where the bubbles were created. This heat transfer process is sometimes desirable because the energy created at the heat transfer surface is quickly and efficiently "carried" away.

Bulk Boiling

As system temperature increases or system pressure drops, the bulk fluid can reach saturation conditions. At this point, the bubbles entering the coolant channel will not collapse. The bubbles will tend to join together and form bigger steam bubbles. This phenomenon is referred to as bulk boiling. Bulk boiling can provide adequate heat transfer provided that the steam bubbles are carried away from the heat transfer surface and the surface is continually wetted with liquid water. When this cannot occur film boiling results.

Film Boiling

When the pressure of a system drops or the flow decreases, the bubbles cannot escape as quickly from the heat transfer surface. Likewise, if the temperature of the heat transfer surface is increased, more bubbles are created. As the temperature continues to increase, more bubbles are formed than can be efficiently carried away. The bubbles grow and group together, covering small areas of the heat transfer surface with a film of steam. This is known as *partial film boiling*. Since steam has a lower convective heat transfer coefficient than water, the steam patches on the heat transfer surface act to insulate the surface making heat transfer more difficult. As the area of the heat transfer surface covered with steam increases, the temperature of the surface increases dramatically, while the heat flux from the surface decreases. This unstable situation continues until the affected surface is covered by a stable blanket of steam, preventing contact between the heat transfer surface and the liquid in the center of the flow channel. The condition after the stable steam blanket has formed is referred to as *film boiling*.

The process of going from nucleate boiling to film boiling is graphically represented in Figure 13. The figure illustrates the effect of boiling on the relationship between the heat flux and the temperature difference between the heat transfer surface and the fluid passing it.

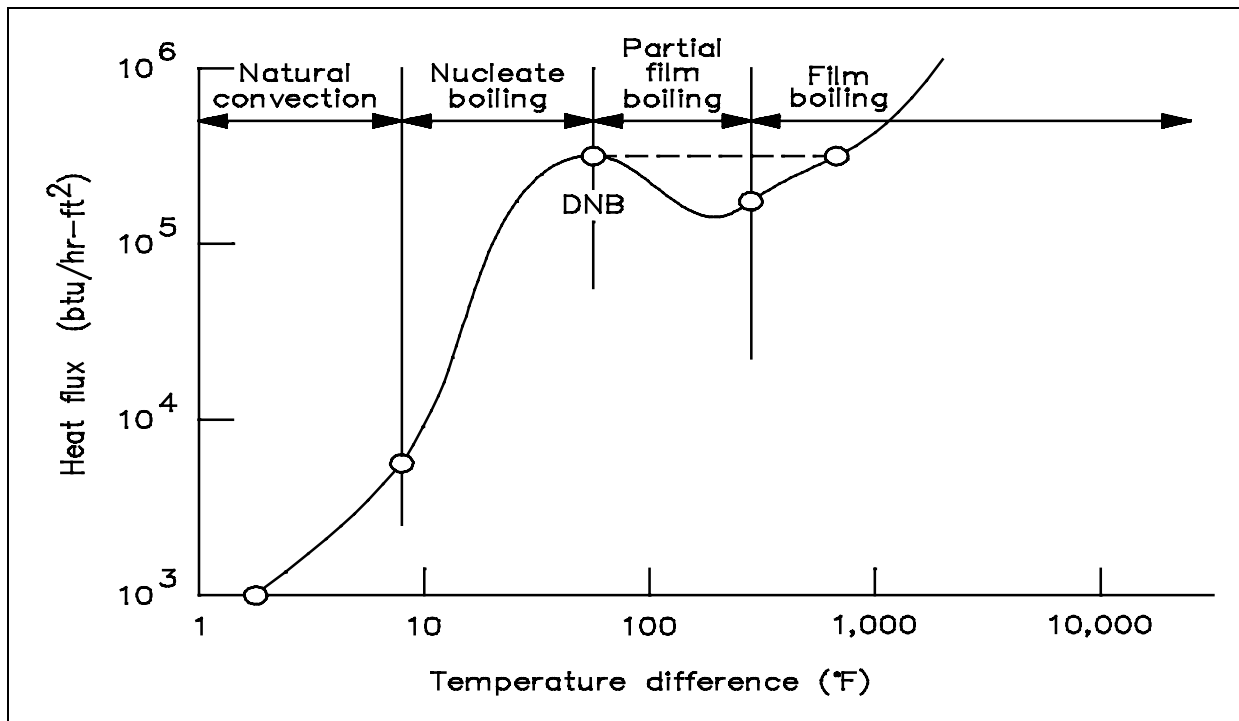

Figure 13 Boiling Heat Transfer Curve

Four regions are represented in Figure 13. The first and second regions show that as heat flux increases, the temperature difference (surface to fluid) does not change very much. Better heat transfer occurs during nucleate boiling than during natural convection. As the heat flux increases, the bubbles become numerous enough that partial film boiling (part of the surface being blanketed with bubbles) occurs. This region is characterized by an increase in temperature difference and a decrease in heat flux. The increase in temperature difference thus causes total film boiling, in which steam completely blankets the heat transfer surface.

Departure from Nucleate Boiling and Critical Heat Flux

In practice, if the heat flux is increased, the transition from nucleate boiling to film boiling occurs suddenly, and the temperature difference increases rapidly, as shown by the dashed line in the figure. The point of transition from nucleate boiling to film boiling is called the point of departure from nucleate boiling, commonly written as DNB. The heat flux associated with DNB is commonly called the critical heat flux (CHF). In many applications, CHF is an important parameter.

For example, in a reactor, if the critical heat flux is exceeded and DNB occurs at any location in the core, the temperature difference required to transfer the heat being produced from the surface of the fuel rod to the reactor coolant increases greatly. If, as could be the case, the temperature increase causes the fuel rod to exceed its design limits, a failure will occur.

The amount of heat transfer by convection can only be determined after the local heat transfer coefficient is determined. Such determination must be based on available experimental data. After experimental data has been correlated by dimensional analysis, it is a general practice to write an equation for the curve that has been drawn through the data and to compare experimental results with those obtained by analytical means. In the application of any empirical equation for forced convection to practical problems, it is important for the student to bear in mind that the predicted values of heat transfer coefficient are not exact. The values of heat transfer coefficients used by students may differ considerably from one student to another, depending on what source "book" the student has used to obtain the information. In turbulent and laminar flow, the accuracy of a heat transfer coefficient predicted from any available equation or graph may be no better than 30%.

Summary

The important information in this chapter is summarized below.

Boiling Heat Transfer Summary

- Nucleate boiling is the formation of small bubbles at a heat transfer surface. The bubbles are swept into the coolant and collapse due to the coolant being a subcooled liquid. Heat transfer is more efficient than for convection.
- Bulk boiling occurs when the bubbles do not collapse due to the coolant being at saturation conditions.
- Film boiling occurs when the heat transfer surface is blanketed with steam bubbles and the heat transfer coefficient rapidly decreases.
- Departure from nucleate boiling (DNB) occurs at the transition from nucleate to film boiling.
- Critical heat flux (CHF) is the heat flux that causes DNB to occur.

HEAT GENERATION

Heat generation and power output in a reactor are related. Reactor power is related to the mass flow rate of the coolant and the temperature difference across the reactor core.

- EO 2.1** **DESCRIBE** the power generation process in a nuclear reactor core and the factors that affect the power generation.
- EO 2.2** **DESCRIBE** the relationship between temperature, flow, and power during operation of a nuclear reactor.
- EO 2.3** **DEFINE** the following terms:
- a. Nuclear enthalpy rise hot channel factor
 - b. Average linear power density
 - c. Nuclear heat flux hot channel factor
 - d. Heat generation rate of a core
 - e. Volumetric thermal source strength
- EO 2.4** **CALCULATE** the average linear power density for an average reactor core fuel rod.
- EO 2.5** **DESCRIBE** a typical reactor core axial and radial flux profile.
- EO 2.6** **DESCRIBE** a typical reactor core fuel rod axial and radial temperature profile.
-

Heat Generation

The heat generation rate in a nuclear core is directly proportional to the fission rate of the fuel and the thermal neutron flux present. On a straight thermodynamic basis, this same heat generation is also related to the fluid temperature difference across the core and the mass flow rate of the fluid passing through the core. Thus, the size of the reactor core is dependent upon and limited by how much liquid can be passed through the core to remove the generated thermal energy. Many other factors affect the amount of heat generated within a reactor core, but its limiting generation rate is based upon how much energy can safely be carried away by the coolant.

The fission rate within a nuclear reactor is controlled by several factors. The density of the fuel, the neutron flux, and the type of fuel all affect the fission rate and, therefore, the heat generation rate. The following equation is presented here to show how the heat generation rate (\dot{Q}) is related to these factors. The terms will be discussed in more detail in the Nuclear Science modules.

$$\dot{Q} = G N \sigma_f \phi V_f \quad (2-14)$$

where:

\dot{Q} = heat generation rate (Btu/sec)

G = energy produced per fission (Btu/fission)

N = number of fissionable fuel nuclei/unit volume (atoms/cm³)

σ_f = microscopic fission cross-section of the fuel (cm²)

ϕ = neutron flux (n/cm²-sec)

V_f = volume of the fuel (cm³)

The thermal power produced by a reactor is directly related to the mass flow rate of the reactor coolant and the temperature difference across the core. The relationship between power, mass flow rate, and temperature is given in Equation 2-14.

$$\dot{Q} = \dot{m} c_p \Delta T \quad (2-15)$$

where:

\dot{Q} = heat generation rate (Btu/hr)

\dot{m} = mass flow rate (lbm/hr)

c_p = specific heat capacity of reactor coolant system (Btu/lbm-°F)

ΔT = temperature difference across core (°F)

For most types of reactors (boiling water reactor excluded), the temperature of the coolant is dependent upon reactor power and coolant flow rate. If flow rate is constant, temperature will vary directly with power. If power is constant, temperature will vary inversely with flow rate.

Flux Profiles

Once the type and amount of fuel is determined, the shape of the neutron flux distribution along the core is established. Both radial and axial flux distributions must be determined. A radial distribution looks at flux from the center of the core out to the edges. An axial distribution looks at flux from the bottom to the top of the core. As seen in Equation 2-14, the fission rate directly affects the heat generation rate within a reactor core. In the core regions of highest flux, the highest heat generation rate will be present.

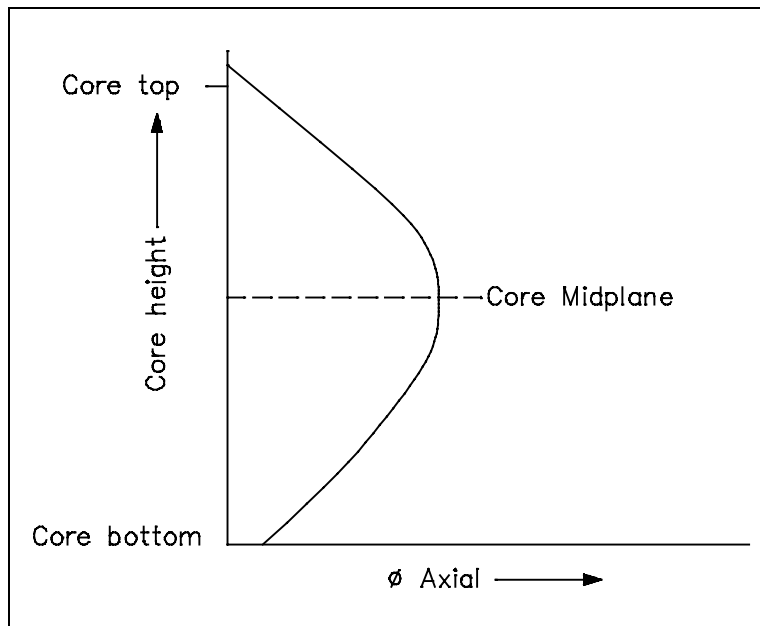

Figure 14 Axial Flux Profile

Many factors affect the axial and radial flux distributions, including the number and type of control rods, the geometry and size of core, the concentration of fission product poisons, and reflector properties. The peak power production regions within each distribution normally occurs near the center of the core, as indicated in Figures 14 and 15, but can vary during transients or as the core ages.

The above figures represent the neutron flux profiles without considering the effects of control rods. Once control rods and reflectors are taken into account, the flux profiles become much flatter although the peak still occurs near the center.

The shape of the profiles can be determined by measuring the ratio of the peak flux to the average flux in the distribution. This peaking factor is referred to as the hot channel factor. A hot channel factor of 1.0 would imply a flat flux profile.

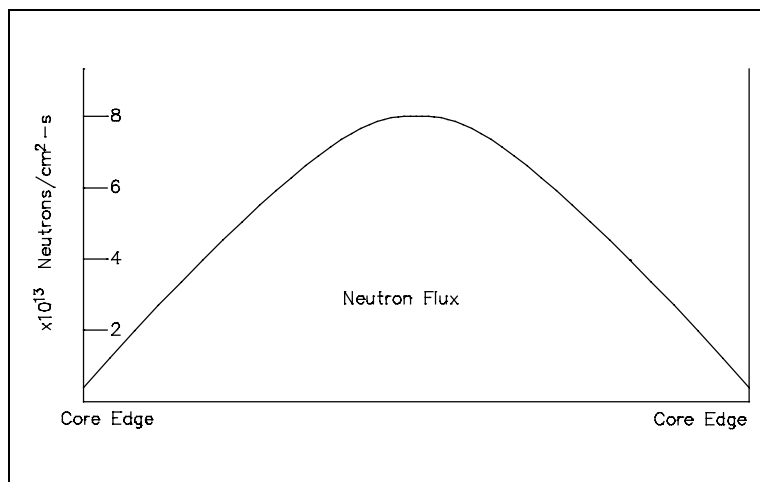

Figure 15 Radial Flux Profile

Thermal Limits

Hot channel factors are calculated values used to take into account various uncertainties in tolerances used in core manufacturing. For example, consider a coolant channel of the minimum acceptable width and length, that happens to be adjacent to a fuel plate with the maximum acceptable fuel loading. In this channel, we would now have less water than in the average channel, receiving more heat than the normal coolant channel. For any given values of core power and flow, this hypothetical channel would be closest to a thermal limit. Therefore, all design considerations are based upon the hot channel factor for each core. The *nuclear heat flux hot channel factor* (HFHCF) is the ratio of the maximum heat flux expected at any area to the average heat flux for the core. The *nuclear enthalpy rise hot channel factor* is the ratio of the total kW heat generation along the fuel rod with the highest total kW to the total kW of the average fuel rod.

Thus the limitation of the peak flux value in a core is directly related to the hot channel factor. However, in discussing flux profiles, "average" values of flux in the core are usually referred to rather than peaks.

Average Linear Power Density

In nuclear reactors, the fuel is usually distributed in individual components which sometimes resemble rods, tubes, or plates. It is possible to determine the average power produced per unit length of fuel component by dividing the total thermal output of the core by the total length of all the fuel components in the core. This quantity is called the *average linear power density*. Common units for measuring average linear power density are kW/ft.

Example:

Calculate the average linear power density for an entire core if a 3400 MW reactor is operating at full power.

Core data is: each fuel rod is 12 ft long
 264 rods/fuel assembly
 193 fuel assemblies in the core

Solution:

$$\begin{aligned} \text{Average linear power density} &= \frac{\text{total thermal power}}{\text{total fuel rod length}} \\ \text{Average linear power density} &= \frac{3.4 \times 10^6 \text{ kW}}{12 (264) (193)} \\ &= 5.56 \text{ kW/ft} \end{aligned}$$

Maximum Local Linear Power Density

The maximum local linear power density when compared to the average linear power density results in the definition of the nuclear heat flux hot channel factor. The nuclear heat flux hot channel factor can be looked at as having axial and radial components that are dependent upon the power densities and, thus, the flux in the radial and axial planes of the core. Once the hot channel factor is known, the maximum local linear power density anywhere in the core can be determined, as demonstrated in the following example.

Example:

If the nuclear heat flux hot channel factor is 1.83, calculate the maximum local linear power density in the core for the previous example (the average linear power density problem).

Solution:

$$\begin{aligned} \text{Maximum linear power density} &= \text{HFHCF} (\text{Av linear power density}) \\ &= 1.83 (5.56) \text{ kW/ft} \\ &= 10.18 \text{ kW/ft} \end{aligned}$$

Normally, nuclear facility operators are provided with the above core power and heat generation distributions, rather than having to calculate them. In addition, various monitoring systems are always employed to provide the operator with a means of monitoring core performance and the proximity of the existing operating conditions to core operational limitations.

Temperature Profiles

Additional areas of interest are the temperature profiles found within the core. A typical axial temperature profile along a coolant channel for a pressurized water reactor (PWR) is shown in Figure 16. As would be expected, the temperature of the coolant will increase throughout the entire length of the channel.

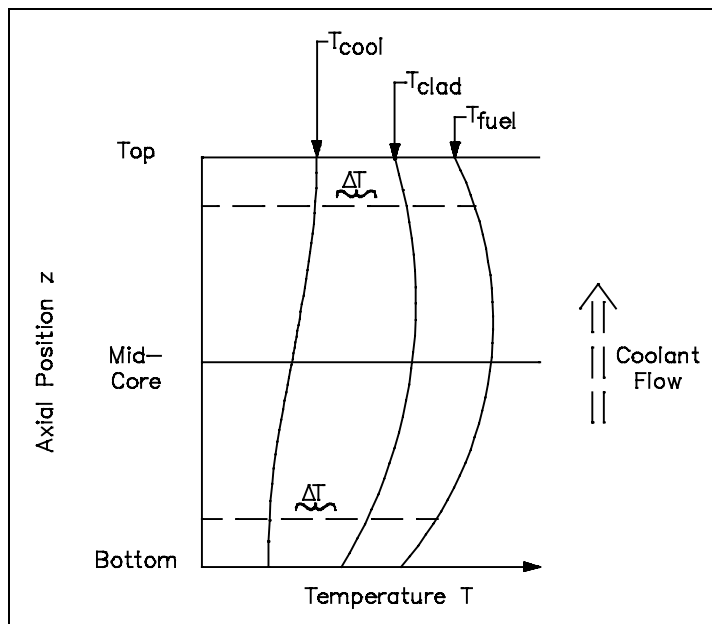

Figure 16 Axial Temperature Profile

However, the rate of increase will vary along with the linear heat flux of the channel. The power density and linear heat rate will follow the neutron flux shape. However, the temperature distributions are skewed by the changing capacity of the coolant to remove the heat energy. Since the coolant increases in temperature as it flows up the channel, the fuel cladding and, thus, the fuel temperatures are higher in the upper axial region of the core.

A radial temperature profile across a reactor core (assuming all channel coolant flows are equal) will basically follow the radial power distribution. The areas with the highest heat generation rate (power) will produce the most heat and have the highest temperatures. A radial temperature profile for an individual fuel rod and coolant channel is shown in Figure 17. The basic shape of the profile will be dependent upon the heat transfer coefficient of the various materials involved. The temperature differential across each material will have to be sufficient to transfer the heat produced. Therefore, if we know the heat transfer coefficient for each material and the heat flux, we can calculate peak fuel temperatures for a given coolant temperature.

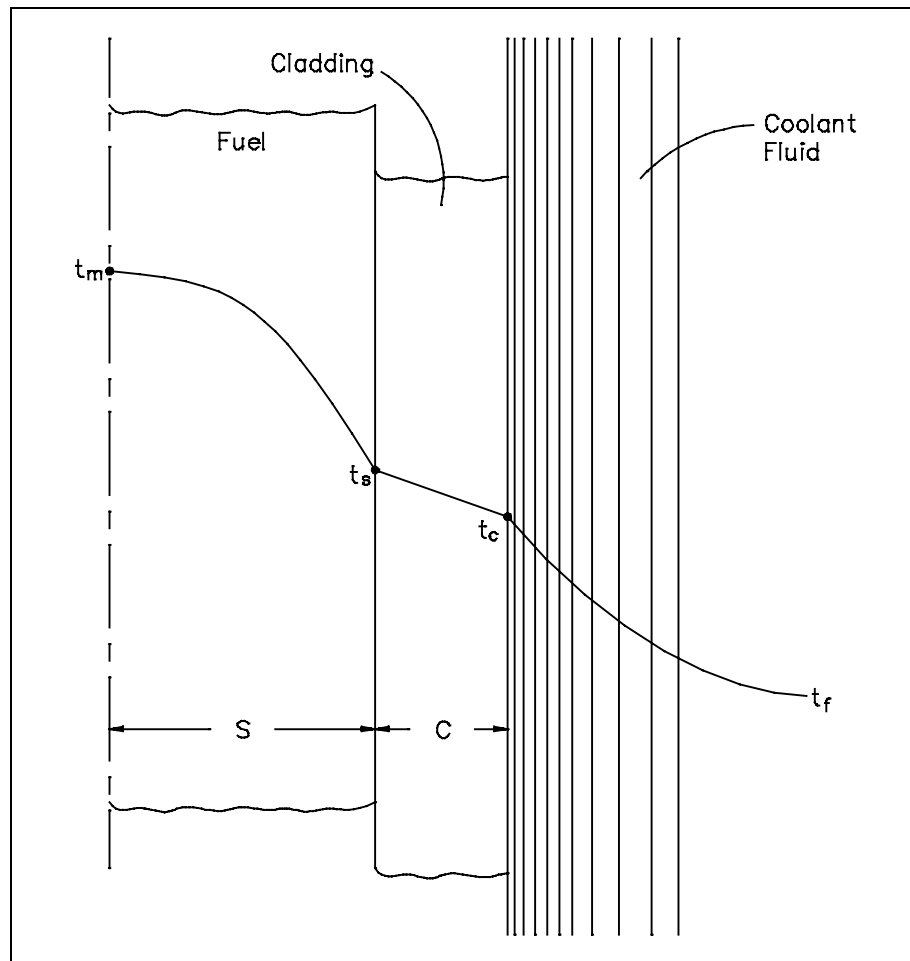

Figure 17 Radial Temperature Profile Across a Fuel Rod and Coolant Channel

Volumetric Thermal Source Strength

The total heat output of a reactor core is called the *heat generation rate*. The heat generation rate divided by the volume of fuel will give the average *volumetric thermal source strength*. The volumetric thermal source strength may be used to calculate the heat output of any section of fuel rod, provided the volume of the section is known.

$$\text{Volumetric Thermal Source Strength} = \frac{\dot{Q}_{\text{core}}}{V_{\text{fuel}}}$$

Fuel Changes During Reactor Operation

During the operation of a nuclear reactor, physical changes occur to the fuel that affect its ability to transfer heat to the coolant. The exact changes that occur are dependant on the type and form of fuel. Some reactors use fuel assemblies that consist of zircalloy tubes containing cylindrical ceramic pellets of uranium dioxide. During manufacture, a small space or gap is left between the fuel pellets and the zircalloy tube (clad). This gap is filled with pressurized helium. As the reactor is operated at power, several physical changes occur in the fuel that affect the gap between the pellets and clad. One change occurs due to high pressure in the coolant outside the clad and the relatively high temperature of the clad during reactor operation. The high temperature and high pressure causes the clad to be pushed in on the pellets by a process referred to as *creep*. Another physical change is caused by the fission process. Each fission event creates two fission product atoms from a fuel atom. Even though each fission product atom is roughly half the mass of the fuel atom, the fission products take up more volume than the original fuel atom. Fission products that are gases can collect together and form small gas bubbles within the fuel pellet. These factors cause the fuel pellets to swell, expanding them out against the clad. So the two processes of pellet swell and clad creep both work to reduce the gap between the fuel and clad.

This change in the gap between the pellet and clad has significant impact on heat transfer from the fuel and operating fuel temperatures. Initially a significant temperature difference exists across the gap to cause heat transfer to take place by convection through the helium gas. As the size of the gap is reduced, a smaller temperature difference can maintain the same heat flux. When the fuel pellets and clad come in contact, heat transfer by conduction replaces convection and the temperature difference between the fuel surface and clad decreases even more. Due to the processes of pellet swell and clad creep, the fuel temperatures of some reactors decrease slightly over time while the heat flux from the fuel and therefore the power of the reactor remain constant.

Not all changes that occur to the fuel during reactor operation work to enhance heat transfer. If the chemistry of the coolant is not carefully controlled within appropriate limits, chemical reactions can take place on the surface of the clad, resulting in the formation of a layer of corrosion products or crud between the metal of the clad and the coolant. Typically, this layer will have a lower thermal conductivity than that of the clad material, so it will act as an insulating blanket, reducing heat transfer.

If this corrosion layer is allowed to form, a larger temperature difference will be required between the coolant and fuel to maintain the same heat flux. Therefore, operation at the same power level will cause higher fuel temperatures after the buildup of corrosion products and crud.

Summary

The important information in this chapter is summarized below:

Heat Generation Summary

- The power generation process in a nuclear core is directly proportional to the fission rate of the fuel and the thermal neutron flux present.
- The thermal power produced by a reactor is directly related to the mass flow rate of the reactor coolant and the temperature difference across the core.
- The nuclear enthalpy rise hot channel factor is the ratio of the total kW heat generation along a fuel rod with the highest total kW, to the total kW of the average fuel rod.
- The average linear power density in the core is the total thermal power divided by the active length of the fuel rods.
- The nuclear heat flux hot channel factor is the ratio of the maximum heat flux expected at any area to the average heat flux for the core.
- The total heat output of a reactor core is called the heat generation rate.
- The heat generation rate divided by the volume of fuel will give the average volumetric thermal source strength.

DECAY HEAT

Decay heat production is a particular problem associated with nuclear reactors. Even though the reactor is shut down, heat is produced from the decay of fission fragments. Limits for each particular reactor are established to prevent damage to fuel assemblies due to decay heat.

- EO 2.7** **DEFINE** the term decay heat.
- EO 2.8** **Given the operating conditions of a reactor core and the necessary formulas, CALCULATE** the core decay heat generation.
- EO 2.9** **DESCRIBE** two categories of methods for removing decay heat from a reactor core.

Reactor Decay Heat Production

A problem peculiar to power generation by nuclear reactors is that of decay heat. In fossil fuel facilities, once the combustion process is halted, there is no further heat generation, and only a relatively small amount of thermal energy is stored in the high temperature of plant components. In a nuclear facility, the fission of heavy atoms such as isotopes of uranium and plutonium results in the formation of highly radioactive fission products. These fission products radioactively decay at a rate determined by the amount and type of radioactive nuclides present. Some radioactive atoms will decay while the reactor is operating and the energy released by their decay will be removed from the core along with the heat produced by the fission process. All radioactive materials that remain in the reactor at the time it is shut down and the fission process halted will continue to decay and release energy. This release of energy by the decay of fission products is called *decay heat*.

The amount of radioactive materials present in the reactor at the time of shutdown is dependent on the power levels at which the reactor operated and the amount of time spent at those power levels. The amount of decay heat is very significant. Typically, the amount of decay heat that will be present in the reactor immediately following shutdown will be roughly 7% of the power level that the reactor operated at prior to shutdown. A reactor operating at 1000 MW will produce 70 MW of decay heat immediately after a shutdown. The amount of decay heat produced in the reactor will decrease as more and more of the radioactive material decays to some stable form. Decay heat may decrease to about 2% of the pre-shutdown power level within the first hour after shutdown and to 1% within the first day. Decay heat will continue to decrease after the first day, but it will decrease at a much slower rate. Decay heat will be significant weeks and even months after the reactor is shutdown.

The design of the reactor must allow for the removal of this decay heat from the core by some means. If adequate heat removal is not available, decay heat will increase the temperatures in the core to the point that fuel melting and core damage will occur. Fuel that has been removed from the reactor will also require some method of removing decay heat if the fuel has been exposed to a significant neutron flux. Each reactor facility will have its own method of removing decay heat from both the reactor core and also any irradiated fuel removed from the core.

Calculation of Decay Heat

The amount of decay heat being generated in a fuel assembly at any time after shutdown can be calculated in two ways. The first way is to calculate the amount of fission products present at the time of shutdown. This is a fairly detailed process and is dependent upon power history. For a given type of fuel, the concentrations, decay energies, and half lives of fission products are known. By starting from a known value, based on power history at shutdown, the decay heat generation rate can be calculated for any time after shutdown.

An exact solution must take into account the fact that there are hundreds of different radionuclides present in the core, each with its own concentration and decay half-life. It is possible to make a rough approximation by using a single half-life that represents the overall decay of the core over a certain period of time. An equation that uses this approximation is Equation 2-16.

$$\dot{Q} = \dot{Q}_o \left(\frac{1}{2} \right)^{\frac{\text{time}}{\text{half-life}}} \quad (2-16)$$

where:

\dot{Q} = decay heat generation rate at some time after shutdown

\dot{Q}_o = initial decay heat immediately after shutdown

time = amount of time since shutdown

half-life = overall decay half-life of the core

Example:

A 250 MW reactor has an unexpected shutdown. From data supplied by the vendor, we know that decay heat at time of shutdown will be 7% of the effective power at time of shutdown and will decrease with a 1 hr half life. Effective power at time of shutdown was calculated to be 120 MW. How much heat removal capability (in units of Btu/hr) will be required 12 hours after shutdown?

Solution:

- (a) First determine the decay heat immediately following shutdown.

$$(120 \text{ MW})(.07) = 8.4 \text{ MW decay heat at shutdown}$$

- (b) Then use Equation 2-15 to determine the decay heat 12 hours later.

$$\begin{aligned} \dot{Q} &= \dot{Q}_o \left(\frac{1}{2} \right)^{\frac{\text{time}}{\text{half-life}}} \\ &= 8.4 \text{ MW} \left(\frac{1}{2} \right)^{\frac{12 \text{ hr}}{1 \text{ hr}}} \\ &= 2.05 \times 10^{-3} \text{ MW} \left(\frac{3.413 \times 10^6 \text{ Btu/hr}}{1 \text{ MW}} \right) \\ &= 7000 \frac{\text{Btu}}{\text{hr}} \end{aligned}$$

The second method is much simpler to use, but is not useful for forecasting heat loads in the future. To calculate the decay heat load at a given point after shutdown, secure any heat removal components from the primary system or spent fuel pool and plot the heatup rate. If the mass of the coolant and the specific heat of the coolant are known, the heat generation rate can be accurately calculated.

$$\dot{Q} = m c_p \frac{\Delta T}{\Delta t} \quad (2-17)$$

where:

\dot{Q} = decay heat (Btu/hr)

m = mass of coolant (lbm)

c_p = specific heat capacity of coolant (Btu/lbm-°F)

ΔT = temperature change of coolant (°F)

Δt = time over which heatup takes place (hr)

Example:

Three days after a planned reactor shutdown, it is desired to perform maintenance on one of two primary heat exchangers. Each heat exchanger is rated at 12,000 Btu/hr. To check the current heat load on the primary system due to decay heat, cooling is secured to both heat exchangers. The primary system heats up at a rate of 0.8°F/hr. The primary system contains 24,000 lbm of coolant with a specific heat capacity of 0.8 Btu/lbm-°F. Will one heat exchanger be sufficient to remove the decay heat?

Solution:

$$\begin{aligned}\dot{Q} &= m c_p \frac{\Delta T}{\Delta t} \\ &= (24,000 \text{ lbm}) \left(0.8 \frac{\text{Btu}}{\text{lbm-}^\circ\text{F}} \right) \left(\frac{0.8^\circ\text{F}}{1 \text{ hr}} \right) \\ &= 15,360 \frac{\text{Btu}}{\text{hr}}\end{aligned}$$

One heat exchanger removes 12,000 Btu/hr.

One heat exchanger will not be sufficient.

Decay Heat Limits

Reactor decay heat can be a major concern. In the worst case scenarios, it can cause melting of and/or damage to the reactor core, as in the case of Three Mile Island. The degree of concern with decay heat will vary according to reactor type and design. There is little concern about core temperature due to decay heat for low power, pool-type reactors.

Each reactor will have some limits during shutdown that are based upon decay heat considerations. These limits may vary because of steam generator pressure, core temperature, or any other parameter that may be related to decay heat generation. Even during refueling processes, heat removal from expended fuel rods is a controlling factor. For each limit developed, there is usually some safety device or protective feature established.

Decay Heat Removal

Methods for removing decay heat from a reactor core can be grouped into two general categories. One category includes methods which circulate fluid through the reactor core in a closed loop, using some type of heat exchanger to transfer heat out of the system. The other category includes methods which operate in an open system, drawing in cool fluid from some source and discharging warmer fluid to some storage area or the environment.

In most reactors, decay heat is normally removed by the same methods used to remove heat generated by fission during reactor operation. Additionally, many reactors are designed such that natural circulation between the core and either its normal heat exchanger or an emergency heat exchanger can remove decay heat. These are examples of the first category of methods for decay heat removal.

If a reactor design is such that decay heat removal is required for core safety, but accidents are possible that will make the closed loop heat transfer methods described above unavailable, then an emergency cooling system of some sort will be included in the reactor design. Generally, emergency cooling systems consist of some reliable source of water that is injected into the core at a relatively low temperature. This water will be heated by the decay heat of the core and exit the reactor via some path where it will either be stored in some structure or released to the environment. Use of this type of system is almost always less desirable than the use of the closed loop systems described above.

Students should research systems, limits, and protective features applicable to their own specific facilities.

Summary

The important information in this chapter is summarized below.

Decay Heat Summary

- Decay heat is the amount of heat generated by decay of fission products after shutdown of the facility.
- The amount of decay heat is dependent on the reactor's power history.
- Methods for removing decay heat usually fall into one of the following categories.
 - Closed loop systems, where coolant is circulated between the reactor and a heat exchanger in a closed loop. The heat exchanger transfers the decay heat to the fluid in the secondary side of the heat exchanger.
 - Once through systems, where coolant from a source is injected into the reactor core. The decay heat is transferred from the fuel assemblies into the coolant, then the coolant leaves the reactor and is either collected in a storage structure or released to the environment.
- The limits for decay heat are calculated to prevent damage to the reactor core.

end of text.

CONCLUDING MATERIAL

Review activities:

DOE - ANL-W, BNL, EG&G Idaho,
EG&G Mound, EG&G Rocky Flats,
LLNL, LANL, MMES, ORAU, REEC_o,
WHC, WINCO, WEMCO, and WSRC.

Preparing activity:

DOE - NE-73
Project Number 6910-0018/2

Intentionally Left Blank