

METRIC

A-A-59940/1

19 November 2013

COMMERCIAL ITEM DESCRIPTION  
SPECIFICATION SHEET

CONNECTORS, FIBER OPTIC, SINGLE FIBER, SMALL FORM FACTOR, LC TYPE

The General Services Administration has authorized the use of this commercial item description (CID), for all federal agencies.

The requirements for acquiring the product described herein shall consist of this specification sheet and A-A-59940.

CLASSIFICATION: This CID uses a classification system that is included in the Part or Identification Number (PIN).

TABLE I. Termination process.

Termination process	Designation
Epoxy polish	1
Quick-connect – fusion splice	2
Quick-connect – mechanical splice	3

TABLE II. Connector type.

Fiber cable class	Designation
MM – UPC (graded-index, glass core and glass cladding, multimode)	1 (or MM)
SM – UPC (dispersion-unshifted, glass core and glass cladding, single-mode)	2 (or SM)
SM – APC (dispersion-unshifted, glass core and glass cladding, single-mode)	3 (or APC)

TABLE III. Temperature range: 1.

Temperature range designation	Operating temperature	Non-operating temperature	Storage temperature
	°C (°F)	°C (°F)	°C (°F)
1	-28 to +65 (-18.4 to +149)	-40 to +70 (-40 to +158)	-40 to +70 (-40 to +158)

Beneficial comments, recommendations, additions, deletions, clarifications, etc. and any data that may improve this document should be sent to: Commander, Naval Sea Systems Command, ATTN: SEA 05S, 1333 Isaac Hull Avenue, SE, Stop 5160, Washington Navy Yard DC 20376-5160 or emailed to [CommandStandards@navy.mil](mailto:CommandStandards@navy.mil), with the subject line "Document Comment". Since contact information can change, you may want to verify the currency of this address information using the ASSIST Online database at <https://assist.dla.mil>.

A-A-59940/1

TABLE IV. Housing type configurations.

Fiber cable class	Designation
Simplex – one optical fiber/ferrule/single ferrule	S
Duplex – one optical fiber/ferrule/two ferrules	D

TABLE V. Strain relief.

Strain relief design	Designation
Pull-proof <sup>1/</sup>	P
Non-pull-proof <sup>2/</sup>	N
NOTES:	
<sup>1/</sup> A connector with pull-proof type strain relief is designed to be used with cable considered to be of non-tight construction. This includes furcation units in accordance with A-A-59729 (2 to 2.4 mm in diameter).	
<sup>2/</sup> A connector with non-pull-proof type strain relief is designed to be used with cable considered to be of tight construction. This includes cable in accordance with MIL-PRF-85045/16 (2 mm in diameter).	

Part or Identification Number (PIN).

**AA59940**      **/01**      :      **X**      **X**      **X**      **X**      **X**  
 CID number    Specification sheet    Termination process (1, 2, or 3) (see [table I](#))    Connector type (1, 2, or 3) (see [table II](#))    Temperature range (1) (see [table III](#))    Housing (S or D) (see [table IV](#))    Strain relief (N or P) (see [table V](#))

PIN example: AA59940/01-111SN is an LC connector for buffered fiber and tight structured OFCC, multimode fiber, simplex housing, operating temperature range of -28 to +65 °C (-18.4 to +149 °F), ultra physical contact polish, and epoxy polish termination method.

TABLE VI. Connector code configuration number: termination process: epoxy polish.

Connector configuration number	Termination process (see <a href="#">table I</a> )	Connector type (see <a href="#">table II</a> )	Temperature range (see <a href="#">table III</a> )	Housing (see <a href="#">table IV</a> )	Strain relief (see <a href="#">table V</a> )
111 SN	1	MM – UPC (1)	1	Simplex (S)	N
111 SP					P
121 SN					N
121 SP					P
111 DN		MM – UPC (1)		Duplex (D)	N
111 DP					P
121 DN					N
121 DP					P
		SM – UPC (2)			

A-A-59940/1

TABLE VII. Connector code configuration number: termination process: fusion splice.

Connector configuration number	Termination process (see <a href="#">table I</a> )	Connector type (see <a href="#">table II</a> )	Temperature range (see <a href="#">table III</a> )	Housing (see <a href="#">table IV</a> )	Strain relief (see <a href="#">table V</a> )
211SN	2	MM – UPC (1)	1	Simplex (S)	N
211 SP					P
221 SN		SM – UPC (2)			N
221 SP					P
231 SN		SM – APC (3)			N
231 SP					P
211 DN		Duplex (D)		MM – UPC (1)	N
211 DP					P
221 DN				SM – UPC (2)	N
221 DP					P
231 DN				SM – APC (3)	N
231 DP					P

TABLE VIII. Connector code configuration number: termination process: mechanical splice.

Connector configuration number	Termination process (see <a href="#">table I</a> )	Connector type (see <a href="#">table II</a> )	Temperature range (see <a href="#">table III</a> )	Housing (see <a href="#">table IV</a> )	Strain relief (see <a href="#">table V</a> )
311 SN	3	MM – UPC (1)	1	Simplex (S)	N
311 SP					P
321 SN		SM – UPC (2)			N
321 SP					P
331 SN		SM – APC (3)			N
331 SP					P
311 DN		Duplex (D)		MM – UPC (1)	N
311 DP					P
321 DN				SM – UPC (2)	N
321 DP					P
331 DN				SM – APC (3)	N
331 DP					P

A-A-59940/1

## DESIGN AND CONSTRUCTION

Interface dimensions. The interface dimensions of the LC connector shall be in accordance with TIA-604-10 [Fiber Optic Connector Intermateability Standards (FOCIS 10)].

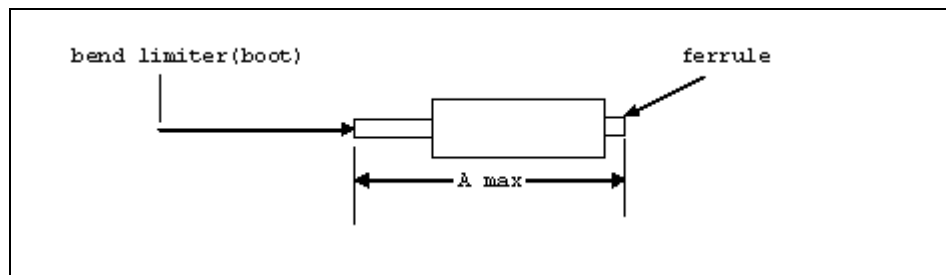
FIGURE 1. Size.TABLE IX. Fiber/cable type compatibility.<sup>1/</sup>

Dimension	Buffered fiber (250/900 $\mu\text{m}$ ) <sup>2/</sup>	OFCC – tight structure (2 mm) <sup>2/</sup>	OFCC – non-tight structure (2 mm) <sup>2/</sup>
A (max)	32 mm	55 mm	55 mm

NOTES:  
<sup>1/</sup> See [table VI](#).  
<sup>2/</sup> See A-A-59940 for additional information.

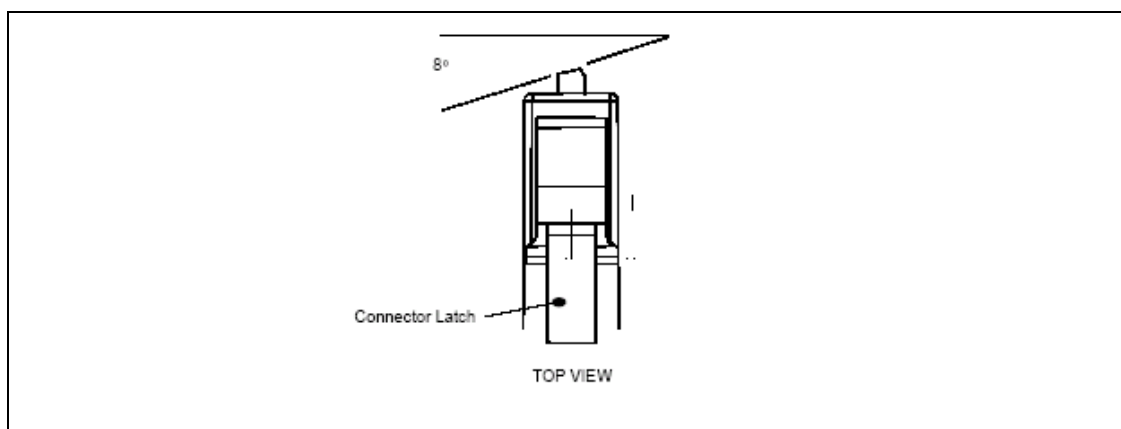
FIGURE 2. LC APC ferrule/angle orientation.

A-A-59940/1

TABLE X. Performance requirements.

<b>Requirement</b>	<b>MM – UPC</b>	<b>SM – UPC</b>	<b>SM – APC</b>
Initial insertion loss (dB)	0.50	0.50	0.50
Insertion loss verification (dB)	0.75	0.75	0.75
Return loss (dB)	<sup>2/</sup>	30/40/45 <sup>1/</sup>	≥58
Color (part of housing or boot)	Beige	Blue or yellow	Green
Endface geometry	<sup>2/</sup>	<sup>2/</sup>	Telcordia GR-326-CORE
NOTES:			
<sup>1/</sup> 30 dB applies to epoxy polish and standard polish connectors, 40 dB applies to epoxy polish enhanced polish connectors, and 45 dB applies to quick-connect connectors.			
<sup>2/</sup> Applicable.			
<sup>3/</sup> Not applicable.			

Crimp tool compatibility. The LC 2-millimeter cordage connector configuration meets all requirements when the crimp sleeve is assembled to the jumper connector using a circular indent ring crimp die with a 2.67±0.08-millimeter (0.105±0.003-inch) minor diameter and a 3.43±0.08-millimeter (0.135±0.003-inch) major diameter or using a hex crimp die with flats measuring 2.947+0.025 millimeters (0.116+0.001 inch) across and 1.25 millimeter (0.049 inch) maximum length.

Fusion splicer compatibility. The LC connector configuration capable of being fusion spliced (see [table VII](#)) shall be capable of assembly using fusion splicers approved to A-A-59799, Configuration 2.

Mechanical splice tool compatibility. The LC connector configuration capable of being mechanically spliced (see [table VII](#)) shall permit fiber preparation and assembly of the splice utilizing tools and supplies available in the standard Navy shipboard fiber optic toolkit, as described in 6872811, 6872813, or 7085185, supplemented with parts and tools provided with the mechanical splice kit.

Conformance inspection. Test performed, test procedure, connector performance, and test sample (specimen) quantity shall be in accordance with [table XI](#) with any exception (such as a modification or addition) listed in this specification sheet. A duplex version of a particular connector PIN shall be recognized as conforming so long as the simplex version has shown to be conforming and the only change from the conforming simplex connector to the duplex connector is that the housing is duplex.

A-A-59940/1

TABLE XI. Conformance inspection.

Group	Inspection	A-A-59940 requirement and test paragraph	Specimen <sup>2/</sup>			
			Connector	Connector on cable Type A	Connector on cable Type B or C	
I	<b>Visual and mechanical inspection</b>					
	Interchangeability and intermateability	3.1.1	1-4	1-8	1-16	
	Interface dimensions	3.1.2				
	Cable strain relief, bend limiter	3.1.3, 3.1.4				
	Optical fiber compatibility	3.1.5				
	Optical fiber attachment (ferrule, quick-connect)	3.1.6				
	Color	3.1.7				
	Endface geometry (quick-connect)	3.1.8				
	Endface condition (quick-connect)	3.1.9				
	Cleaved fiber stub endface condition (quick-connect)	3.1.10				
	Ferrule extension and contact force	3.1.11				
	Maintainability (cleaning, field termination, dust cover)	3.6.1, 3.6.2, 3.6.3				
	Size, mass, workmanship, marking	3.7, 3.8, 3.9, 3.10				
II	<b>Performance</b>					
	Insertion loss, initial	3.5.1	N/A	1-8	1-16	
	Ambient light susceptibility	3.5.2				
	Return loss	3.5.3				
III	<b>Mechanical properties</b>					
	Cable pull-out	3.3.1	N/A	N/A	1-8	
	Fiber pull-out	3.3.2		N/A		
	Fiber-to-ferrule pull-out	3.3.2.1		1-4	N/A	
	Fiber-to-splice pull-out	3.3.2.1		6-8	N/A	
	Flex	3.3.3		N/A	N/A	1-8
	Twist	3.3.4				
	Force to engage/disengage	3.3.5				
	Impact	3.3.6				
	90-degree cable pull-out	3.3.7				
	Strength of coupling mechanism	3.3.8				
	Mating durability	3.3.9				
	Shock-COTS	3.3.10				
Vibration	3.3.11					

A-A-59940/1

Group	Inspection	A-A-59940 requirement and test paragraph	Specimen <sup>2/</sup>		
			Connector	Connector on cable Type A	Connector on cable Type B or C
IV	<b>Environmental properties</b>				
	Temperature	3.4.1	N/A	N/A	9-16
	Temperature humidity cycling	3.4.2			
	Temperature cycling	3.4.3			
	Life aging (temperature life)	3.4.4			
	Thermal shock	3.4.5			
V	<b>Materials</b>				
	Non-metallic materials (adhesives, index matching gel, sealing compounds)	3.2.1	1/	N/A	N/A
	Metallic materials (dissimilar metals)	3.2.2			
	Toxic and hazardous products and formulations	3.2.3			
	Fungus	3.2.4			
	Oxygen index	3.2.5			
	Salt spray	3.2.6			
	Flammability	3.2.7			
	Radioactive materials	3.2.8			
	Lubricants	3.2.9			
	Sealing compounds	3.2.10			
	Liquid materials	3.2.11			
	Ferrule	3.2.12			
NOTE:					
<sup>1/</sup> Applicable connector material samples may be provided in lieu of connector samples as test requirement and method require. Material certification may be provided as proof of conformance.					
<sup>2/</sup> Specimen shall be simplex connectors.					

**Intended use.** LC connectors in accordance with this specification sheet are intended to be used in a sheltered environment with commercial fiber optic cable, fiber optic cable in accordance with MIL-PRF-85045, and blown optical fiber tube furcation units in accordance with A-A-59729.

A-A-59940/1

## MILITARY INTERESTS

### Custodians:

Army – CR  
Navy – SH  
Air Force – 11

### Preparing Activity:

Navy – SH  
(Project 6060-2013-007)

### Review Activities:

Air Force – 13, 19, 93, 99  
Misc – DI

NOTE: The activities listed above were interested in this document as of the date of this document. Since organizations and responsibilities can change, you should verify the currency of the information above using the ASSIST Online database at <https://assist.dla.mil>.