

[INCH-POUND]
 A-A-59733
5 December 2002
 SUPERSEDING
 CS4730-0005
 12 July 1977

COMMERCIAL ITEM DESCRIPTION

CAP LUBRICATION FITTING

The General Services Administration has authorized the use of this commercial item description for all federal agencies.

1. **SCOPE.** This CID covers the general requirements for Lubrication Fitting Caps. Caps covered by this CID are intended for commercial/industrial applications.
2. **CLASSIFICATION.** This CID uses a classification system which is included in the Part Identification Number (PIN) as shown (see 7.1).

<u>PIN</u>	<u>Color</u>
AA59733-001	Black
AA59733-002	Blue
AA59733-003	Brown
AA59733-004	Green
AA59733-005	Red
AA59733-006	White
AA59733-007	Yellow

3. SALIENT CHARACTERISTICS.

3.1 Dimensions. Cap(s) supplied to this CID shall be as specified herein and figure 1.

3.2 Material. The material shall conform to ASTM D4976, Group 2, Class 3 or 4.

3.3 Marking. Cap(s) supplied to this CID shall have the manufacturer's (MFR's) standard commercial part number and this CID PIN marked as specified in the contract or order (see 7.4).

4. **REGULATORY REQUIREMENTS.** The offeror/contractor is encouraged to use recovered materials to the maximum extent practicable, in accordance with paragraph 23.403 of the Federal Acquisition Regulation (FAR).

Beneficial comments, recommendations, additions, deletions, clarifications, etc., and any data which may improve this document should be sent to: Defense Supply Center, Columbus, ATTN: DSCC-VAI, Post Office Box 3990, Columbus OH 43216-5000, or telephone (614) 692-0538, or facsimile (FAX) (614) 692-6939.

AMSC N/A
DISTRIBUTION STATEMENT A. Approved for public release; distribution is unlimited.

FSC 4730

A-A-59733

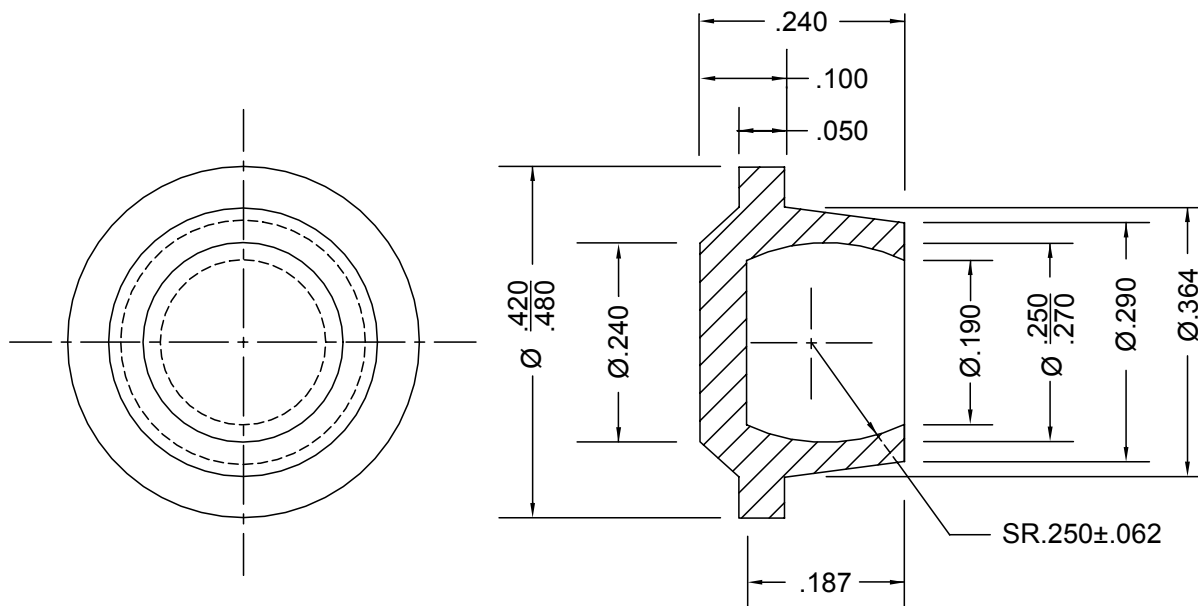

NOTES:

1. DIMENSIONS ARE IN INCHES.
2. TOLERANCE: DECIMALS $\pm .010$ UNLESS OTHERWISE SPECIFIED.

Figure 1. Cap lubrication fitting.

5. PRODUCT CONFORMANCE PROVISIONS.

5.1 Product conformance. The products provided shall meet the salient characteristics of this CID, conform to the producer's own drawings, specifications, standards, and quality assurance practices, and be the same product offered for sale in the commercial market. The Government reserves the right to require proof of such conformance.

6. PACKAGING. Preservation, packing, and marking shall be as specified in the contract or order.

7. NOTES.

7.1 PIN. The PIN should be used for Government purposes to buy commercial products to this CID. See section 2 for PIN format example.

7.2 Commercial and Government Entity (CAGE) code. For ordering purposes, inventory control, and submission of these caps to DSCC under the Military Parts Control Advisory Group (MPCAG) evaluation program, CAGE code 58536 should be used.

A-A-59733

7.3 Source of documents.

INDUSTRY STANDARDS

AMERICAN SOCIETY FOR TESTING AND MATERIALS

ASTM D4976 - Standard Specification for Polyethylene Plastics Molding and Extrusion Materials.

(Application for copies should be addressed to the Society for Testing and Materials, 100 Barr Harbor Drive, West Conshohocken, PA 19248-2959.)

(Industry association specifications and standards are generally available for reference from libraries. They are also distributed among technical groups and using Federal agencies.)

7.4 Ordering data. The contract or order should specify the following:

- a. CID document number, revision, and PIN.
- b. Marking requirements (see 3.3).
- c. Product conformance provisions (see 5.1).
- d. Packaging requirements.

7.5 Commercial products. As part of the market analysis and research effort, this CID was coordinated with the following manufacturers of commercial products. At the time of CID preparation and coordination, these manufacturers were known to have commercial products that would meet the requirements of this CID. (NOTE: This information should not be considered as a list of approved manufacturers or used to restrict procurement to only the manufacturers shown.)

A-A-59733

<u>MFRs CAGE</u>	<u>MFR's Name & Address</u>
23540	Niagara Plastics 7090 Edinboro Road Erie, PA 16509-4497 Phone 1-800-457-5236, 1-800-485-0465 1-814-868-3671 FAX 1-800-358-4391 E-MAIL - plastics@niagaraplastics.com URL http://niagaraplastics.com
1L397	GKS Inc. 25670 1st Street Westlake, OH 4145
03296	Nylon Molding Corp NMC Group Inc. 2755 Thompson Creek Road Pomona, CA 91767-1861 E-Mail - nmcinfo@nmcgroup.com
050R4	Patriot Logistics 86 Broadway Freeport, NY 11520-0000 Phone 1-516-377-3300 Fax 1-516-377-4373 E-Mail - patriotvalve@msn.com
62727	Mid-State Sales Inc. 1101 Gahanna Parkway Columbus, OH 43230-6600 Phone 1-614-864-1811 E-Mail - jodi.maynard@midstate-sales.com
8N281	Edwards Aircraft Co. 6050 Grissom Parkway Titusville, FL 32780-7903
60117	Rosco Intl Corp 95 N. Remington Road Columbus, OH 43209-1442 Phone 1-614-497-8119 Fax 1-614-497-1905
28375	Spectron Inc. 14 Bates Street Dayton, OH 45402-1326 Phone 1-937-461-5590 Fax 1-937-461-5594 E-Mail - lparr@spectroninc.com

7.6 Part number (P/N) supersession data. These CID part numbers, Table I, supersede the part numbers identified on Defense Construction Supply Center drawing CS-4730-0005 which is cancelled. This information is being provided to assist in reducing proliferation in the Government inventory system.

A-A-59733

TABLE I. P/N data.

Part number	Drawing P/N	(NAVORD)	MFR's CAGE	MFR's P/N <u>1/</u>	NSN
AA59733-001	CS4730-0005PC6	12-Z-12163-6	23540 1L397	522	4730-00-270-3916
AA59733-002	CS4730-0005PC4	12-Z-12163-4	03296		4730-00-270-3917
AA59733-003	CS4730-0005PC5	12-Z-12163-5			4730-00-270-3918
AA59733-004	CS4730-0005PC3	12-Z-12163-3	050R4		4730-00-270-3919
AA59733-005	CS4730-0005PC1	12-Z-12163-1	62727		4730-00-270-3920
AA59733-006	CS4730-0005PC7	12-Z-12163-7	8N281 28375 60117		4730-00-270-3921
AA59733-007	CS4730-0005PC2	12-Z-12163-2			4730-00-27-3922

1/ The manufacturer's P/N shall not be used for procurement to the requirements of this CID.

At the time of preparation of this CID, the aforementioned commercial products were reviewed and could be replaced by the CID PIN shown. For actual part marking requirements see 3.3.

7.7 Government users. To acquire information on obtaining these Caps from the Government inventory system, contact the DSCC call center: Defense Supply Center Columbus Office Code: DSCC-AB, Post Office Box 3990, Columbus, OH 43216-5000, or telephone (614) 692-2771, or (614) 692-3191.

7.7.1 National stock number (NSN). Table I includes a list of NSN's assigned which correspond to this CID. The list is for information only and may not be indicative of all possible NSN's associated with this CID. For up to date information on assigned NSN's, please contact the aforementioned DSCC office (See 7.7).

MILITARY INTEREST:

CIVIL AGENCY COORDINATING ACTIVITY:

GSA/FSS

Custodians:
Army - AV
Navy - AS

Preparing activity:
DLA - CC

(Project 4730-2174)

Review activities:
Navy - SA, OS