

INCH-POUND

A-A-59614/3

13 January 2014

COMMERCIAL ITEM DESCRIPTION  
SPECIFICATION SHEET

COUPLING ASSEMBLY, HOSE (GARDEN, WATER, AND WATER SUCTION),  
LONG SHANK WITH OCTAGON OR HEX SWIVEL

The General Services Administration has authorized the use  
of this commercial item description for all federal agencies.

The complete requirements for procuring the hose coupling assemblies described herein shall consist of this document and the latest issue in effect of A-A-59614.

CLASSIFICATION/PART OR IDENTIFICATION NUMBER (PIN). This commercial item description (CID) specification sheet uses a classification system which is included in the PIN as shown in the following example (see NOTES).

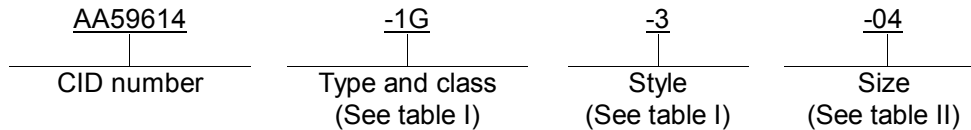

SALIENT CHARACTERISTICS.

Interface and physical dimensions. Coupling assemblies supplied to this CID specification sheet shall meet the general requirements specified in A-A-59614 and be as specified herein (see figure 1).

Clamps. Unless otherwise specified, clamps shall be types A through F, conforming to A-A-52506.

Tightening provisions. The male section shall have either lugs or wrench flats, and the swivel nut on the female section shall have rocker lugs, pin lugs, or wrench flats.

Construction. Unless otherwise specified, type I coupling parts shall be cast or machined from copper alloy (brass), zinc-base alloy, stainless steel, or steel and coupling components shall consist of the following (see figure 1):

- a. Female section.
- b. Swivel nut for female section.
- c. Male section.
- d. Gasket recess in swivel (recess may be omitted provided the standard commercial gasket does not fall out when the two sections are disconnected).
- e. Clamps (one for each male and female section, or ferrules (outside crimp)).

## A-A-59614/3

**Class A couplings.** When attached to hose, class A couplings (garden hose) shall be able to withstand an internal hydrostatic pressure of 100 psi for at least one minute without showing any signs of leakage.

**Class AA couplings.** When attached to hose, class AA couplings shall be able to withstand an internal hydrostatic pressure of 300 psi for sizes .50 through 1 inch, 250 psi for sizes 1.25 and 1.50 inch, 200 psi for sizes 2.00 through 4.00 inch, and 100 psi for sizes 4.50 through 5 inch, for at least one minute without showing any signs of leakage.

TABLE I. PIN codes for type, class, and style.

Type	Class	Style	PIN type and class code	PIN style code
I	A	3	1G	3
	AA	3	1W	3

TABLE II. Size codes for all types. 1/

Class A size	Class AA size	PIN size code
.50	—	-04
.625	—	-05
.75	.75	-06
—	1.00	-08
—	1.25	-10
—	1.50	-12
—	2.00	-16
—	2.50	-20
—	3.00	-24
—	3.50	-28
—	4.00	-32
—	4.50	-34
—	5.00	-40
—	6.00	-48

1/ The size indicates the nominal size of the coupling to fit the hose with that inside diameter (ID). For example, size .50 is for a coupling to fit the .50 inch ID hose.

**Dimensions.** Dimension A shall be sized so as not to restrict the free flow of the hose attached; B shall be as required to accommodate the hose specified; and C shall be as required to meet the pull-off and leakage requirements and to accommodate the required clamp(s) or ferrule(s) (see figure 1). Clamps or ferrules shall not extend closer than .062 inch to the end of the shank.

A-A-59614/3

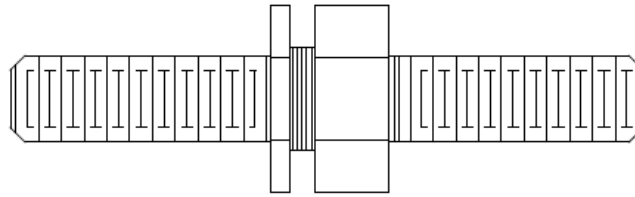

CLASS A, AA, STYLE 3

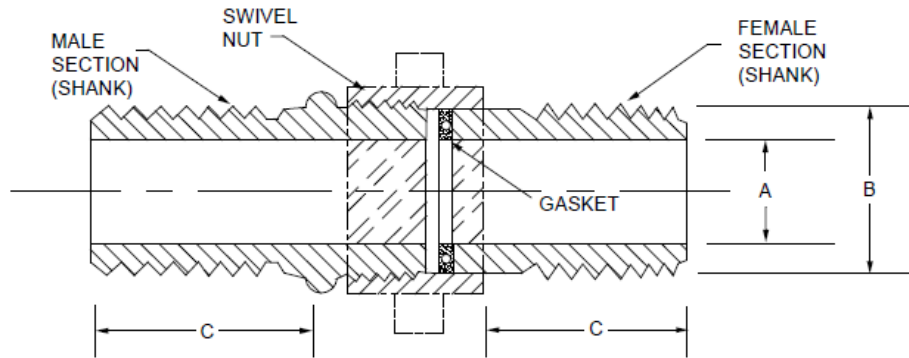

Dimension C (minimum) (inches).

For hose size	Styles 3 and 4
.50	1.125
.625	1.125
.75	1.125
1.00	1.125
1.25	2.00
1.50	2.50
2.00	3.50
2.50	4.00
3.00	5.00
3.50	5.50
4.00	5.75
4.50	5.875
5.00	5.875
6.00	6.50

FIGURE 1. Style 3 couplings.

A-A-59614/3

## NOTES.

PIN. The PIN should be used for Government purposes to buy commercial products to this CID specification sheet. See classification information for PIN format example.

Source of documents.

## Federal Specifications

A-A-52506 - Clamp, Hose

## COMMERCIAL ITEM DESCRIPTIONS

A-A-59614 -Coupling Assembly, Hose (Garden, Water, And Water Suction)

(Copies of these documents are available online at <https://assist.dla.mil/quicksearch/> or from the Standardization Document Order Desk, 700 Robbins Avenue, Building 4D, Philadelphia, PA 19111-5094.)

Commercial products. As part of the market analysis and research effort, this CID specification sheet was coordinated with the following manufacturers of commercial products. At the time of CID specification sheet preparation and coordination, these manufacturers were known to have commercial products that would meet the requirements of this CID specification sheet. (NOTE: This information should not be considered as a list of approved manufacturers or be used to restrict procurement to only the manufacturers shown.)

<u>MFR's CAGE</u>	<u>MFR's name and address</u>
1U339	Labarge Products, Inc. 2900 Brannon Avenue St. Louis, MO 63139 Phone number: 1-314-776-2900 Fax number: 1-314-776-6444 <a href="mailto:sales@whsmithco.com">sales@whsmithco.com</a> <a href="http://www.labargepro.com">www.labargepro.com</a>
30659	Moon American Inc. 167-B SW Cutoff Worcester, MA 01604 Phone number: 1-507-798-8887 Fax number: 1-508-798-7839 <a href="mailto:sales@moon-american.com">sales@moon-american.com</a> <a href="http://www.moon-american.com">www.moon-american.com</a>

## A-A-59614/3

Part number (P/N) supersession data. These CID PINs supersede the following Federal specification part numbers as shown. This information is being provided to assist in reducing proliferation in the Government inventory system.

TABLE III. P/N data.

PIN	Superseded P/N	MFR's CAGE	MFR's P/N <u>1/</u>	NSN
AA59614-1W-3-12	WWC624-1W-3-12			4730-00-289-4623

1/ The manufacturer's P/N shall not be used for procurement to the requirements of this CID. At the time of preparation of this CID, the aforementioned commercial products were reviewed and could be replaced by the CID PIN shown. For actual part marking requirements see A-A-59614.

## MILITARY INTERESTS:

## Custodians:

Army - AT  
Navy - SH  
Air Force - 99  
DLA - CC

## Review activities:

Navy - SA  
Air Force - 71

## CIVIL AGENCY COORDINATING ACTIVITY:

GSA-FSS

Preparing activity:  
DLA - CC

(Project 4730-2013-085)

NOTE: The activities listed above were interested in this document as the date of this document. Since organizations and responsibilities can change, you should verify the currency of the information above using the ASSIST Online database at <https://assist.dla.mil/>.