

INCH-POUND

A-A-59178B
 02 February 2016
 SUPERSEDING
 A-A-59178A
 12 October 2004

COMMERCIAL ITEM DESCRIPTION

NIPPLE, ELECTRICAL TERMINAL

The General Services Administration has authorized the use of this commercial item description for all federal agencies.

1. **SCOPE.** This commercial item description (CID) establishes the government acquisition requirements for silicone rubber electrical terminal nipples used to protect electrical terminals from the elements.
2. **CLASSIFICATION.** The nipples shall be classified by the sizes shown in [table I](#). The size to be furnished shall be as specified ([see 7.3\(b\)](#)).

Table I. Electrical terminal sizes and dimensions.

Size code	A Length	B Height	C Thickness	D Diameter	E Diameter	F Diameter	G Diameter	H Diameter
1	1.38	0.56	0.06	0.40	0.63	0.16	0.41	0.76
2	2.50	1.00	0.06	0.56	0.82	0.31	0.56	0.95
3	2.50	1.00	0.06	0.56	0.82	0.43	0.68	0.95
4	2.50	1.00	0.06	0.56	0.82	0.56	0.82	0.95

Note: All dimensions are in inches. Tolerances are ± 0.02 .

- 2.1 **Color.** The electrical terminal nipple color shall be as specified in the solicitation or contract order ([see 7.3\(c\)](#)). If color is not specified, color shall be at the manufacturer's discretion.

Color A - Black
 Color B - Blue
 Color C - Brick Red
 Color D - Orange

Beneficial comments, recommendations, additions, deletions, clarifications, etc. and any data that may improve this document should be sent to: DLA Aviation, VEB, 8000 Jefferson Davis Highway, Richmond, VA 23297-5616 or e-mailed to STDZNMGT@dla.mil. Since contact information can change, you may want to verify the currency of this address information using the ASSIST Online database at <https://assist.dla.mil>.

A-A-59178B

Color E - White
 Color F - Yellow
 Color G - Other

3. SALIENT CHARACTERISTICS

3.1 General requirements. The electrical terminal nipple shall be manufactured from silicone rubber to the dimensions shown in [figure 1](#). The silicone rubber shall conform to the requirements of Society of Automotive Engineers (SAE) AMS 3302, "Silicone Rubber, General Purpose, 50 Durometer" (DoD adopted). The manufacturer's identification and part number shall be legibly molded on each nipple.

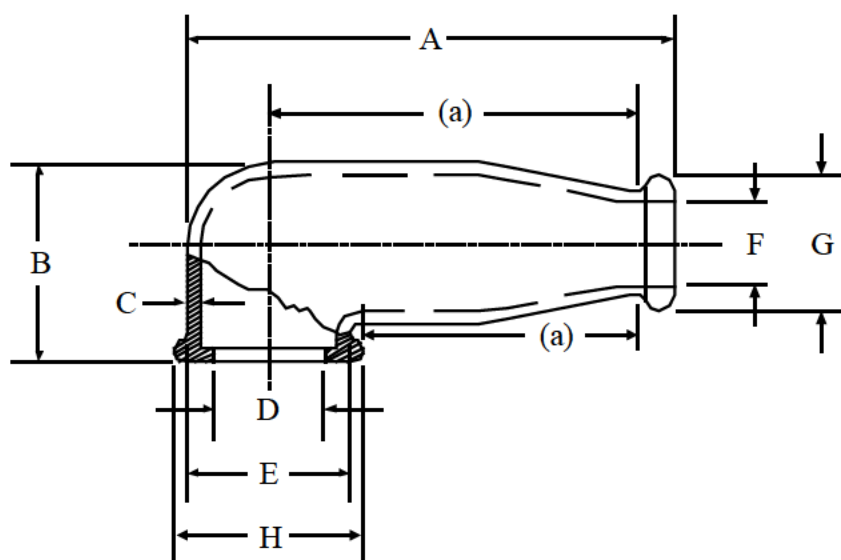

Note: (a) Contour within these limits may vary to suit individual manufacturer's design.

FIGURE 1. Dimensional requirements.

4. REGULATORY REQUIREMENTS

4.1 Recovered materials. The offeror/contractor is encouraged to use recovered materials to the maximum extent practicable, in accordance with paragraph 23.403 of the Federal Acquisition Regulation (FAR).

5. PRODUCT CONFORMANCE PROVISIONS

5.1 Product conformance. The products provided shall meet the salient characteristics of this CID, conform to the producer's own drawings, specifications, standards, and quality assurance practices, and be the same product offered for sale in the commercial marketplace. The government reserves the right to require proof of such conformance.

A-A-59178B

5.2 Market acceptability. The product offered must have been previously sold either to the government or on the commercial market.

6. PACKAGING

6.1 Preservation, packing, and marking. Preservation, packing, and marking shall be specified in the acquisition order (see 7.3(d)).

7. NOTES

7.1 Part or identification number (PIN). The following PIN procedure is for government purposes and does not constitute a requirement for the contractor or manufacturer.

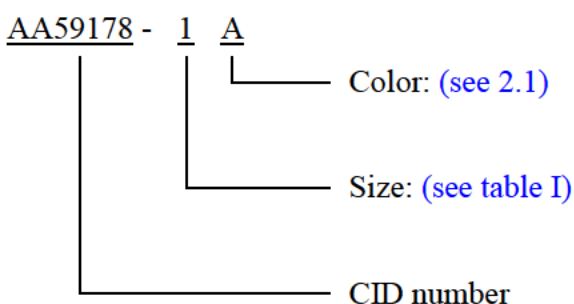

Example of reference part number when no color is specified: AA59178 - 1

Example of reference part number when Black color is specified: AA59178 - 1A

7.2 Sources of documents.

7.2.1 FAR. Copies of the FAR are available online at <http://www.gpo.gov/>.

7.2.2 SAE standards. Copies of SAE documents are available online at <http://www.sae.org/>.

7.3 Ordering data. The acquisition order should specify the following:

- a. CID document number, revision, and CID PIN.
- b. Size of nipple required (see 2).
- c. Color (see 2.1).
- d. Preservation, packing, and marking (see 6.1).

7.4 Subject term (key word) listing.

rubber
silicone

A-A-59178B

MILITARY INTERESTS:

Custodians:

Navy - AS
Air Force - 85
DLA - GS

Review Activities:

Navy - MC
Air Force - 99

CIVIL AGENCY
COORDINATING ACTIVITY:

GSA - FAS

Preparing Activity:

DLA - GS8

(Project 5975-2016-004)

NOTE: The activities listed above were interested in this document as of the date of this document. Since organizations and responsibilities can change, you should verify the currency of the information above using the ASSIST Online database at <https://assist.dla.mil>.