

INCH-POUND

A-A-59102C  
December 7, 2015  
SUPERSEDING  
A-A-59102B  
September 1, 2009

## COMMERCIAL ITEM DESCRIPTION

## TABLES, ALUMINUM, GENERAL PURPOSE

The General Services Administration has authorized the use of this commercial item description for all federal agencies.

## 1. SCOPE

1.1 Scope. This commercial item description (CID) covers general purpose aluminum tables with folding legs.

1.2 Intended use. The aluminum tables will be used as work tables and dining tables in a field environment. Food will be prepared directly on the table top.

## 2. CLASSIFICATION

2.1 Classification. The tables shall conform to the following types, sizes, and colors as specified (see 7.1).

## Type I - Nonadjustable legs

Size 1 - 36 inches wide x 72 inches long x 29 inches high, with a maximum weight of 48 pounds.

Size 2 - 36 inches wide x 96 inches long x 29 inches high, with a maximum weight of 60 pounds.

Size 3 - 30 inches wide x 48 inches long x 29 inches high, with a maximum weight of 30 pounds.

Size 4 - 30 inches wide x 48 inches long x 36 inches high, with a maximum weight of 35 pounds.

Comments, suggestions or questions on this document should be addressed to US Army Research, Development and Engineering Command, Natick Soldier Center, AMSRD-NSC-CF-S, 10 General Greene Ave, Natick, MA 01760-5018, or emailed to [Janice.A.Knowlton.Civ@mail.mil](mailto:Janice.A.Knowlton.Civ@mail.mil). Since contact information can change, you may want to verify the currency of this address information using the ASSIST Online database at <https://assist.dla.mil/online/start/>

## Type II - Adjustable legs

Size 5 - 30 inches wide x 48 inches long with adjustable legs from 24 1/2 to 34 1/2 inches high with a maximum weight of 42 pounds.

Color 1 - Green

Color 2 - Tan

Color 3 - Commercial color selection

## 3. SALIENT CHARACTERISTICS

3.1 Design and construction. The tables shall be of the types, sizes, and colors as specified (see 2.1 and 7.1). The tables shall have legs which can be folded flat against the table bottom. The maximum folded depth of the legs shall not exceed 4 1/2 inches maximum projection out from the underside of the table in order to permit nesting of the tables for storage and transportation. The size 5 table shall have legs that are adjustable in 1-inch increments to permit the height of the table to range from 24 1/2 to 34 1/2 inches. All exposed surfaces on corners, edges, and table top shall be smooth with no visible protrusions or burrs. The table top shall not be ribbed or have gaps on the surface where water and/or food can collect. The table top shall be constructed with integral stiffener ribs underneath and all table top corners should have a radius no less than 3/8" and no more than 3/4". A stainless steel table top or table top wrap made of 304 SS or 316 SS conforming to ASTM A240/A240M is also acceptable as long as all other weight/design requirements are met.

3.2 Load capacity. The table in its fully opened position, shall support a uniformly distributed static load of 1600 pounds without collapsing or exhibiting permanent deformation of the tabletop, frame or leg assemblies.

3.3 Finish. The table shall have a fade, chip and scratch resistant, epoxy powder-coated finish that meets NSF-51 standards for food contact or a similarly durable anodized coating which meets NSF-51 standards for food contact. If constructed with a stainless steel table top or wrap, the material finish should be 2B and no coating or paint shall be applied. Legs shall be epoxy powder-coated to color match the table top or shall be black in color. It is not required that the legs' powder coated finish meet NSF-51 standards, but it shall be fade, chip and scratch resistant.

3.4 Color. The color of the table shall be either green (color 1), tan (color 2) or commercial color (color 3) as specified (see 7.1 and 7.4). Tables of a specific lot shall not exhibit any variation in shade from the specific color selected and specified in the contract for the production lot. Color 3 tables shall not reflect a "government unique" requirement, but shall be selected from the manufacturer's standard commercial colors or lack thereof. The selected color or lack thereof shall be cited in the contract or purchase order.

3.5 Legs. The legs shall have positive acting locking devices when the table is fully opened. Leg bottoms shall be equipped with tips or caps for floor protection. Adjustable and non-adjustable folding leg assemblies shall have H style construction and shall be aluminum.

3.6 Drop test. A folded table shall be capable of being dropped on each corner from a height of 2 feet onto a smooth hard surface without structural damage such as cracking, crushing, or damage that affects performance.

3.7 Finish temperature resistance. The tabletop finish shall not exhibit evidence of blistering, discoloring or cracking after direct contact with a standard full sized sheet pan having a temperature of no more than 350°F for one minute and no more than 160°F for 10 minutes.

3.8 Operating conditions. The tables shall be capable of withstanding any one extreme weather condition, i.e., rain/snow/high humidity (>90%) and temperatures of -40°F to 120°F with sunlight for seven consecutive days without exhibiting any evidence of corrosion, delamination/cracking of material coatings or mechanical degradation.

3.9 Metric products. Products manufactured to metric dimensions will be considered on an equal basis with those manufactured using inch-pound units, provided they fall within the tolerances specified using conversion tables contained in the latest revision of IEEE/ASTM SI10, and all other requirements of this document are met. If a product is manufactured to metric dimensions and those dimensions exceed the tolerances specified in the inch-pound units, a request should be made to the contracting officer to determine if the product is acceptable. The contracting officer has the option of accepting or rejecting the product.

#### 4. REGULATORY REQUIREMENTS

4.1 Contractor-recovered materials. The offeror/contractor is encouraged to use recovered materials to the maximum extent practicable, in accordance with paragraph 23.403 of the Federal Acquisition Regulation (FAR).

#### 5. PRODUCT CONFORMANCE PROVISIONS

5.1 Product conformance provisions. The tables provided shall meet the salient characteristics of this commercial item description, shall conform to the producer's own drawings, specifications, standards and quality assurance practices, and be the same product that has been sold in the commercial marketplace, or is the same product that has successfully been delivered to the Government on a previous contract or purchase order. The Government reserves the right to require proof of such conformance prior to first delivery and thereafter as may be otherwise provided for under the provisions of the contract.

## 6. PACKAGING

6.1 Packaging. Preservation, packing and marking shall be as specified in the contract or purchase order (see 7.1).

## 7. NOTES

7.1 Ordering data. Acquisition documents must specify the following:

- a. Title, number and date of this document
- b. Type, size, and color required (see 2.1)
- c. Packaging requirements (see 6.1)

7.2 Sources for non-government association documents:

AMERICAN SOCIETY FOR TESTING AND MATERIALS (ASTM)

INSTITUTE OF ELECTRICAL AND ELECTRONICS ENGINEERS

SI10 - Standard for Use of the International Systems of Units (SI): The Modern Metric System may be obtained from: Institute of Electrical and Electronics Engineers, Inc., 305 East 47<sup>th</sup> Street, New York, NY 10017, [www.ieee.org](http://www.ieee.org); or the American Society for Testing and Materials, 100 Barr Harbor Drive, West Conshohocken, PA 19428-2959, or online at [www.astm.org](http://www.astm.org)

7.3 Sources of supply. Manufacturers whose products are known to meet the requirements of, this document in whole or in part are listed below; however, competition is not limited to these companies.

Southern Aluminum Manufacturing, Inc  
5 HWY 82 West  
P.O. Box 884 Magnolia, AR  
71754 Tel: 800-221-0408

7.4 Table color. Past experience has shown that a table with a green color conforming to No.34095/34082, or a tan color conforming to No.33446/30257 of FED-STD-595 were found to be acceptable.

7.5 Part identification number (PIN). The PINs to be used for items required by this CID are as follows:

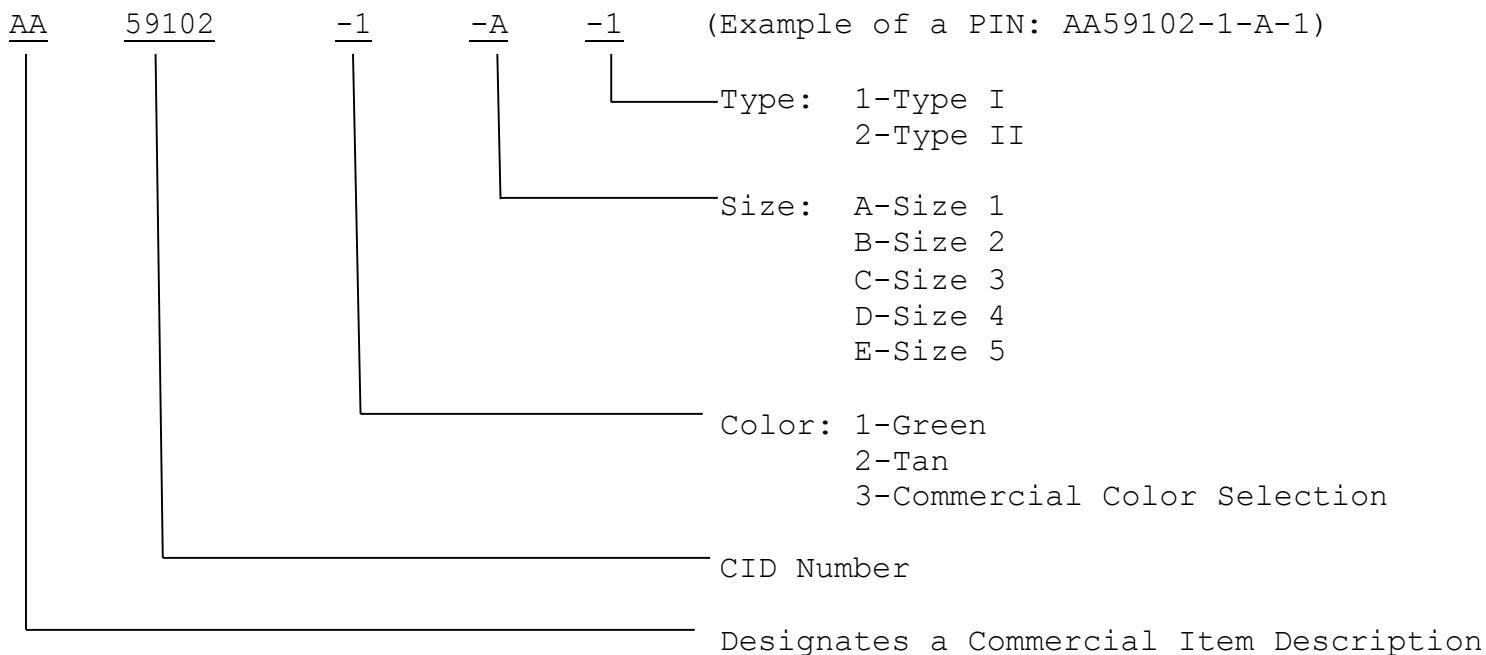

MILITARY INTERESTS:

CIVIL AGENCY COORDINATING ACTIVITY:

Custodians

GSA-FAS

Army - GL

Preparing Activity

Navy - YD

Army - GL

Review Activities

Project No. 7195-2016-001

Army - QM1

NOTE: The activities listed above were interested in this document as of the date of this document. Since organizations and responsibilities can change, you should verify the currency of the information above using the ASSIST Online database at <https://assist.dla.mil/online/start/>.