

INCH-POUND

A-A-55629

31 JULY 1997

SUPRESEDING

MS24679E

15 MARCH 1990

COMMERCIAL ITEM DESCRIPTION

NUT, PLAIN, CAP, LOW CROWN
UNC-2B AND UNF-2B

The General Services Administration has authorized the use of this commercial item description for all federal agencies.

1. Scope. This Commercial Item Description (CID) depicts the requirements for a UNC-2B and UNF-2B Low, Crown Cap, Plain Nut.
2. Salient characteristics.
 - 2.1 Materials:
 - 2.1.1 Steel, carbon, Types UNS (G10050) thru (G10400), (G11160) thru (G11370) or (G12110) thru (G12144).
 - 2.1.2 Steel, corrosion resistant, Types UNS (3XXXX) series.
 - 2.1.3 Copper alloys UNS (C23000) thru (C64600).
 - 2.1.4 Aluminum alloys UNS (A92017), (A96061), or (A96262).
 - 2.1.5 Nylon in accordance with ASTM D4066, Group 1, Class 1 or 2 color natural white.
 - 2.2 Protective finish:
 - 2.2.1 Carbon steel cap nuts shall be cadmium plate in accordance with QQ-P-416, Type II, Class 2.
Cadmium plate cap nuts should be used only on aerospace applications. No additional codes required for part number.
Zinc plate in accordance with ASTM B633 FE/ZN 5 Type II. Add letter "Z" to end of part number for zinc plate carbon steel cap nut.
Nickel plate in accordance with QQ-N-290 Class 2. Add letter "N" to end of part number for nickel plate carbon steel cap nut.
 - 2.2.2 Steel, corrosion resistant cap nuts shall be cleaned, descaled and passivated in accordance with ASTM A967. No additional codes required for part number.
 - 2.2.3 Copper alloy cap nuts shall be black oxide coated in accordance with MIL-F-495. No additional codes required for part number.
Nickel plate in accordance with QQ-N-290 Class 2. Add letter "N" to end of part number for nickel plate copper alloy cap nut.
Plain cap nut with brite with no surface finish. Add letter "P" to end of part number.
 - 2.2.4 Aluminum alloy cap nut shall be anodize in accordance with MIL-A-8625 Class 1. No additional codes required for part number.

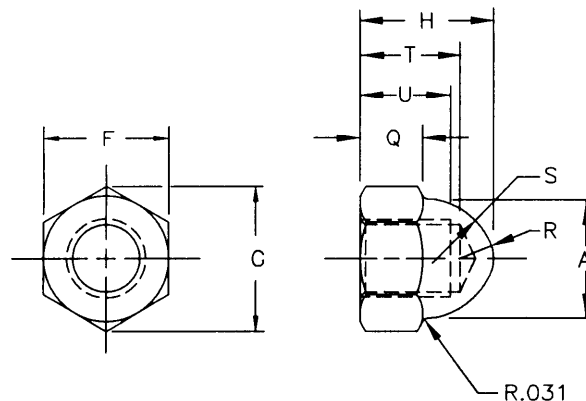

BENEFICIAL COMMENTS, (RECOMMENDATIONS, ADDITION, DELETIONS, CLARIFICATIONS, ETC., AND DATA WHICH MAY IMPROVE THIS DOCUMENT SHOULD BE SENT TO: DEFENSE INDUSTRIAL SUPPLY CENTER, ATTN: DISC-ECC, 700 ROBINS AVENUE, PHILADELPHIA, PA. 19111-5096.

A-A-55629

Table I. Dash numbers

Dash numbers					Size	Thread -2B
Carbon Steel	Cres	Brass	Nylon	Aluminum		
1	21	411	511	611	.138	32UNC
61	81	201	301	811		40UNF
2	22	412	512	612	.164	32UNC
62	82	202	302	812		36UNF
3	23	413	513	613	.190	24UNC
63	83	203	303	813		32UNF
5	25	415	515	615	.250	20UNC
65	85	205	305	815		28UNF
6	26	416	516	616	.3125	18UNC
66	86	206	306	816		24UNF
7	27	417	517	617	.375	16UNC
67	87	207	307	817		24UNF
8	28	418	518	618	.4375	14UNC
68	88	208	318	818		20UNF
9	29	419	519	619	.500	13UNC
69	89	209	309	819		20UNF
10	30	420	520	620	.5625	12UNC
70	90	210	320	820		10UNF
11	31	421	521	621	.625	11UNC
71	91	211	311	821		18UNF
12	32	422	522	622	.750	10UNC
72	92	212	312	822		16UNF
13	33	423	523	623	.875	9UNC
73	93	213	323	823		14UNF
14	34	424	524	624	1.000	8UNC
74	94	214	314	824		12UNF
15	35	425	525	625	1.125	7UNC
75	95	215	325	825		12UNF
16	36	426	526	626	1.250	7UNC
76	96	216	316	826		12UNF

A-A-55629

3. Quality Conformance Provisions.

- 3.1 The suppliers shall be responsible for those in process controls and inspections necessary to supply a product consistently conforming to the requirements of this document.
- 3.2 Upon request, the suppliers will certify with documented test/inspection evidence, that the part supplied meets the requirements of this document.

4. Notes:

- 4.1 All dimensions are in inches, unless otherwise specified. All dimensions and tolerances shall be in accordance with SAE J483.
- 4.2 Interpret drawing in accordance with ASME Y14.5M.
- 4.3 Preservation, packing, and marking shall be as specified in the contract or order.
- 4.4 Cap nuts manufactured prior to Commercial Item Description (CID) A-A-55629 are acceptable up to two years from the date on A-A-55629.
- 4.5 The part identification number (PIN) shall consist of the basic CID number followed by a dash number from Table I, and a surface finish code when applicable.

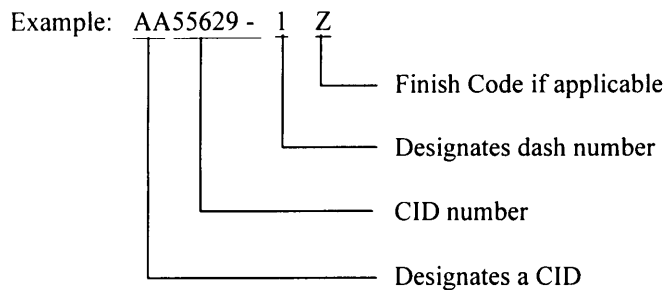

A-A-55629-1Z indicates Nut, plain, cap, low crown, .138-32 UNC-2B thread, carbon steel, Zinc plated.

Custodians:

Air Force-99
 Army - AR
 Navy - SH

Preparing activity:

DLA-IS
 (Project 5310-2306-01)

Review activities:

Army - AV, AT
 Navy-AS, MC, OS,