

INCH-POUND

A-A-55590A
 31 October 1997
 SUPERSEDING
 A-A-55590
 31 October 1994

COMMERCIAL ITEM DESCRIPTION

HINGE, BUTT, CONTINUOUS (PIANO)
 .040 THICKNESS, .091 PIN DIA

The General Services Administration has authorized the use of this
 Commercial Item Description for all Federal Agencies.

1. SCOPE. This Commercial Item Description (CID) covers commercial and industrial quality, continuous butt piano hinges suitable for use on cases, chests, and any other adaptable surface.
2. SALIENT CHARACTERISTICS.
 - 2.1 Butt hinges and pin hinge furnished under this CID shall conform to the dimensions as specified in Table I and figure below.

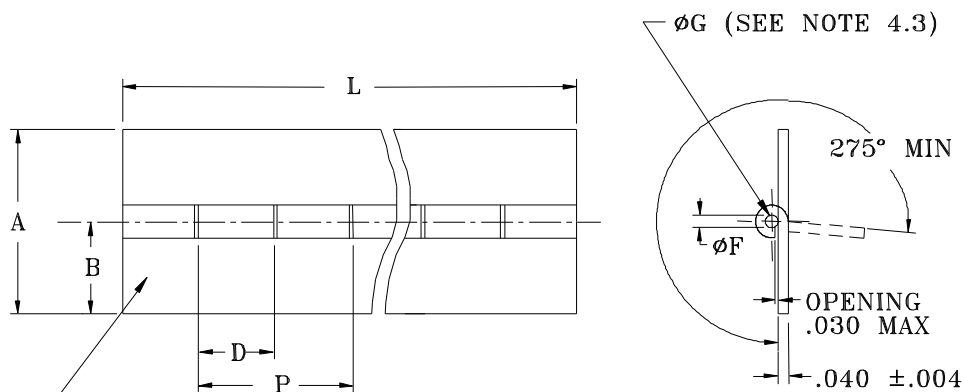

IMPRESS PART IDENTIFICATION NUMBER AT A MAXIMUM OF 5 INCH INTERVALS

TABLE I. DASH NUMBERS AND DIMENSIONS

DASH No.	WIDTH		KNUCKLE LENGTH D ^{1/}	PITCH P ^{2/}	KNUCKLE ØF +.007 -.001	PIN ØG	STOCK LENGTH L ±.03
	A REF	B ±.031					
8	-	-	-	-	-	.091 ±.001	72.00 SEE SAL. CHAR. 2.6
9	1.062	.531	.490 +.002 -.008	1.000 ±.015	.096		
10	1.250	.625					
11	1.500	.750					
12	2.000	1.000					
13	1.062	.531	.623 +.000 -.010	1.250 +.015 -.003	.096		
14	1.250	.625					
15	1.500	.750					
16	2.000	1.000					

^{1/} SEE SAL. CHAR. 2.4

^{2/} SEE SAL. CHAR. 2.5

BENEFICIAL COMMENTS, RECOMMENDATIONS, ADDITIONS, CLARIFICATIONS, ETC., AND DATA WHICH MAY IMPROVE THIS DOCUMENT SHOULD BE SENT TO: DEFENSE INDUSTRIAL SUPPLY CENTER, ATTN: DISC-EED, 700 ROBBINS AVENUE, PHILADELPHIA, PA. 19111-5096.

A-A-55590A

2.2 MATERIAL:

- A. Aluminum-leaf-Temper, H24 or H34 half-hard, (UNS A95052) in accordance with QQ-A-250/8.
Aluminum-pin-Temper, half-hard, (UNS A95052) in accordance with QQ-A-225/7.
- B. Brass-leaf-Alloy 268 (UNS C26800) temper HO2, in accordance with ASTM B36.
Copper-pin-Alloy 260 (UNS C26000) temper HO2, in accordance with ASTM B134.
- C. Corrosion resistant steel-leaf-Class 301 (UNS S30100), 302 (UNS S30200)
or 304 (UNS S30400), condition A, temper annealed, in accordance with QQ-S-766.
Corrosion resistant steel-pin-Form 1, condition B, composition 302 (UNS S30200), 304 (UNS S30400),
305 (UNS S30500) and 316 (UNS S31600) in accordance with ASTM A313.
- D. Carbon-steel-leaf-Cold-rolled, temper no. 4 in accordance with QQ-S-698.
Carbon-steel-pin-Composition 1010 (UNS G10100), 1020 (UNS G10200),. in accordance with ASTM A641.
- E. Carbon steel leaf-cold-rolled, temper no. 4 in accordance with QQ-S-698.
Copper-pin-Alloy 260 (UNS C26000), temper HO2 in accordance with ASTM B134.

2.3 FINISH: Material A, B and D shall be plain (uncoated). When specified, material A shall be chemical conversion coated in accordance with MIL-C-5541, class 1A, material B shall be clear coated (one mil minimum) in accordance with A-A-344, and material D shall be zinc plated in accordance with ASTM B633, TYPE II, FE/ZN 13. Material C shall be passivated in accordance with QQ- P-35. Material E shall be cadmium plated in accordance with QQ-P-416, Type II, Class 1.

2.4. Knuckles: End knuckles shall be a minimum of 1/2 of knuckle.

2.5 Pitch: Cumulative tolerance on pitch is $\pm .015$ inches in any 36 inch segment.

2.6 Hinges shall be stocked and issued in lengths of 72.00 inches or 72.50 inches as specified. Application may be of any length within the above length.

2.7 Workmanship. The hinges furnished shall be free from imperfections which may impair durability or serviceability.

3. QUALITY ASSURANCE PROVISIONS.

3.1 Product conformance. The products provided shall meet the salient characteristics of this commercial item description, conform to the producer's own drawings, specifications, standards, and the quality assurance practices, and be the same product offered for sale in the commercial market. The government reserves the right to require proof of such performance.

4. NOTES:

4.1 Unless otherwise specified, all dimensions are in inches.

4.2 Unless otherwise specified in the contract or purchase order, packaging shall be in accordance with ASTM D3951.

4.3 Pin without butt leaves will be supplied when the part identification number specifies dash 8.

4.4 The part number identification number (PIN) shall consist of the basic commercial item description number followed by a dash number from Table I, and material code. When protective finish is required for material A or D, add "F" to the PIN.

Example: AA55590-10 B

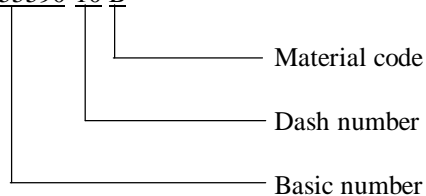

A-A-55590A

Military Interests:

Custodian:

Army-AR
Navy-AS
Air Force-99

Review activities:

Army-AT, AV, MI
Navy-MC
Air Force-82

Civil Agency Coordination Activity:

GSA-FSS

Preparing Activity:

DLA-IS

(Project No. 5340-2397)