

INCH-POUND

A-A-55589A
 31 October 1997
 SUPERSEDING
 A-A-55589
 31 October 1994

COMMERCIAL ITEM DESCRIPTION

HINGE, BUTT, CONTINUOUS (PIANO)
 .032 THICKNESS, .063 PIN DIA

The General Services Administration has authorized the use of this Commercial Item Description for all Federal Agencies.

1. SCOPE. This Commercial Item Description (CID) covers commercial and industrial quality, continuous butt piano hinges suitable for use on cases, chests, and any other adaptable surface.

2. SALIENT CHARACTERISTICS.

2.1 Butt hinges and pin hinge furnished under this CID shall conform to the dimensions as specified in Table I and figure below.

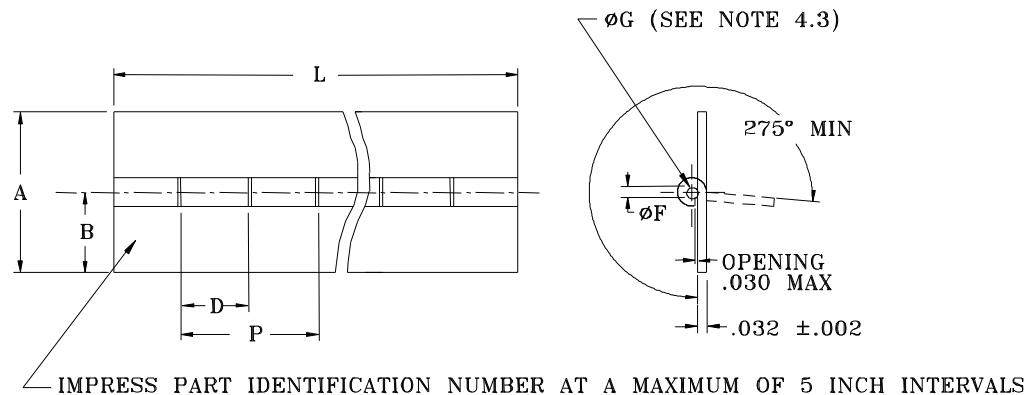

TABLE I. DASH NUMBERS AND DIMENSIONS

DASH No.	WIDTH		KNUCKLE LENGTH D ^{1/} +.002 -.008	PITCH P ^{2/}	KNUCKLE ØF +.007 -.001	PIN ØG	STOCK LENGTH L ±.03
	A REF	B ±.031					
6	.750	.375					
7	1.000	.500					72.00
8	1.062	.531	.490	1.000	.067	062 ±.001	SEE SAL. CHAR.
9	1.250	.625		±.015			2.6
10	1.500	.750					
11	-	-	-	-	-		

^{1/} SEE SAL. CHAR. 2.4

^{2/} SEE SAL. CHAR. 2.5

BENEFICIAL COMMENTS, RECOMMENDATIONS, ADDITIONS, DELETIONS, CLARIFICATIONS, ETC., AND DATA WHICH MAY IMPROVE THIS DOCUMENT SHOULD BE SENT TO: DEFENSE INDUSTRIAL SUPPLY CENTER, ATTN: DISC-EED, 700 ROBBINS AVENUE, PHILADELPHIA, PA. 19111-5096.

A-A-55589A

2.2 MATERIAL:

- A. Aluminum leaf - Temper, H24 or H34 half-hard, (UNS A95052) in accordance with QQ-A-250/8.
Aluminum pin - Temper, half-hard, (UNS A95052) in accordance with QQ-A-225/7.
- B. Brass leaf - Alloy 268 (UNS C26800) temper HO2, in accordance with ASTM B36.
Copper pin - Alloy 260 (UNS C26000) temper HO2, in accordance with ASTM B134.
- C. Corrosion resistant steel leaf - Class 301 (UNS S30100), 302 (UNS S30200) or 304 (UNS S30400), condition A, temper annealed, in accordance with QQ-S-766.
Corrosion resistant steel pin - Form 1, condition B, composition 302 (UNS S30200), 304 (UNS S30400), 305 (UNS S30500) and 316 (UNS S31600) in accordance with ASTM A313.
- D. Carbon steel leaf - Cold-rolled, temper no. 4 in accordance with QQ-S-698.
Carbon steel pin - Composition 1010 (UNS G10100), 1020 (UNS G10200),. in accordance with ASTM A641.
- E. Carbon steel leaf - Cold rolled, temper no. 4 in accordance with QQ-S-698.
Copper pin - Alloy 260 (UNS C26000), temper HO2 in accordance with ASTM B134.

2.3 FINISH: Material A, B and D shall be plain (uncoated). When specified, material A shall be chemical conversion coated in accordance with MIL-C-5541, class 1A, material B shall be clear coated (one mil minimum) in accordance with A-A-344, and material D shall be zinc plated in accordance with ASTM B633, TYPE II, FE/ZN 13. Material C shall be passivated in accordance with QQ- P-35. Material E shall be cadmium plated in accordance with QQ-P-416, Type II, Class 1.

2.4. Knuckles: End knuckles shall be a minimum of 1/2 of knuckle.

2.5 Pitch: Cumulative tolerance on pitch is \pm .015 inches in any 36 inch segment.

2.6 Hinges shall be stocked and issued in lengths of 72.00 inches. Application may be of any length within the above length.

2.7 Workmanship. The hinges furnished shall be free from imperfections which may impair durability or serviceability.

3. QUALITY ASSURANCE PROVISIONS.

3.1 Product conformance. The products provided shall meet the salient characteristics of this commercial item description, conform to the producer's own drawings, specifications, standards, and the quality assurance practices, and be the same product offered for sale in the commercial market. The government reserves the right to require proof of such performance.

4. NOTES:

4.1 Unless otherwise specified, all dimensions are in inches.

4.2 Unless otherwise specified in the contract or purchase order, packaging shall be in accordance with ASTM D3951.

4.3 Pin without butt leaves will be supplied when the part identification number specifies dash 11.

4.4 The part number identification number (PIN) shall consist of the basic commercial item description number followed by a dash number from Table I, and material code. When protective finish is required for material A or D, add "F" to the PIN.

Example: AA55589-6B

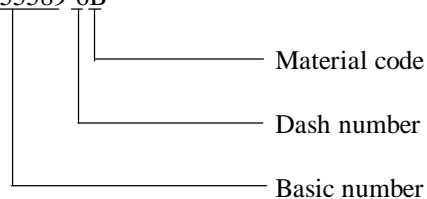

A-A-55589A

Military Interests:

Custodian:

Army-AR

Navy-AS

Air Force-99

Review activities:

Army-MI

Navy-MC

Air Force-82

Civil Agency Coordination Activity:

GSA-FSS

Preparing Activity:

DLA-IS

(Project No. 5340-2396)