

[INCH-POUND]  
 A-A-55532  
 30 January 1996

### COMMERCIAL ITEM DESCRIPTION

#### CONNECTORS, TELECOMMUNICATION, POLARIZED SHELL, PLUG, MALE PRINTED CIRCUIT BOARD, SOLDER CONTACT, SCREWLOCK

The General Services Administration has authorized  
 the use of this commercial item description (CID).

1. SCOPE. This CID covers the general requirements for a polarized shell, plug, electrical digital interface bus connector. These connectors are designed for use in telecommunication equipment, particularly as an interface between computerized equipment and telephone lines. These connectors may also be used in such systems as satellite ground stations, aircraft ground test equipment, and simulators. Connectors covered by this CID are intended for commercial/industrial applications and shall not be used in military systems needing stringent environmental and electrical requirements.

2. CLASSIFICATION. This CID uses a classification system which is included in the Part or Identification Number (PIN) as shown in the following example (see 7.1).

#### 2.1 Part or identifying number (PIN)

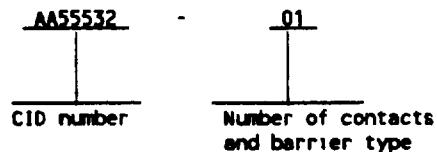

#### 3. Salient characteristics.

3.1 Design, construction, and dimensions. Design, construction, and dimensions shall be as specified on figure 1.

3.2 Connector shells. Shell material shall be corrosion resistant steel in accordance with ASTM-A-109.

3.3 Connector shell finish. Connector shell shall be zinc plated in accordance with ASTM-B-633, type RS, followed by a clear chromate conversion in accordance with ASTM-B-633 class 3, type II.

3.4 Contacts. The contacts shall be formed of a high conductive, high strength copper alloy with gold over nickel plating in the contact area.

3.5 Connector insulator. Connector housings shall be molded from self-extinguishing thermoplastic material for high impact and dielectric strength.

3.6 Contact rating. Contacts shall be rated at 5 amperes maximum per contact.

3.7 Insulation resistance. 5,000 megohms minimum.

3.8 Contact retention. Contact retention force shall be 8.90 newtons (2 pounds) minimum.

3.9 Durability. Durability shall consist of 200 cycles of mating and unmating and upon completion the termination resistance shall not exceed 6 milliohms maximum. There shall be no indication of physical damage.

3.10 Operating temperature. The operating temperature range shall be from -40°C to 105°C

3.11 Termination resistance. The contact resistance shall be 6 milliohms maximum initial

3.12 Dielectric withstanding voltage. There shall be no breakdown of the insulating material when subjected to a minimum of 500 V root mean square (rms) for 5 seconds minimum between adjacent contacts of the mated connector assemblies.

A-A-55532

3.13 Mating and unmating force Connector mating and unmating force shall be as specified in table 1.

TABLE 1. Mating and unmating force.

Size	Mating (maximum)	Unmating (minimum)
14	31.14 newtons (7 pounds)	8.90 newtons (2 pounds)
24	53.38 newtons (12 pounds)	17.79 newtons (4 pounds)
36	80.07 newtons (18 pounds)	26.69 newtons (6 pounds)
50	111.21 newtons (25 pounds)	31.14 newtons (7 pounds)

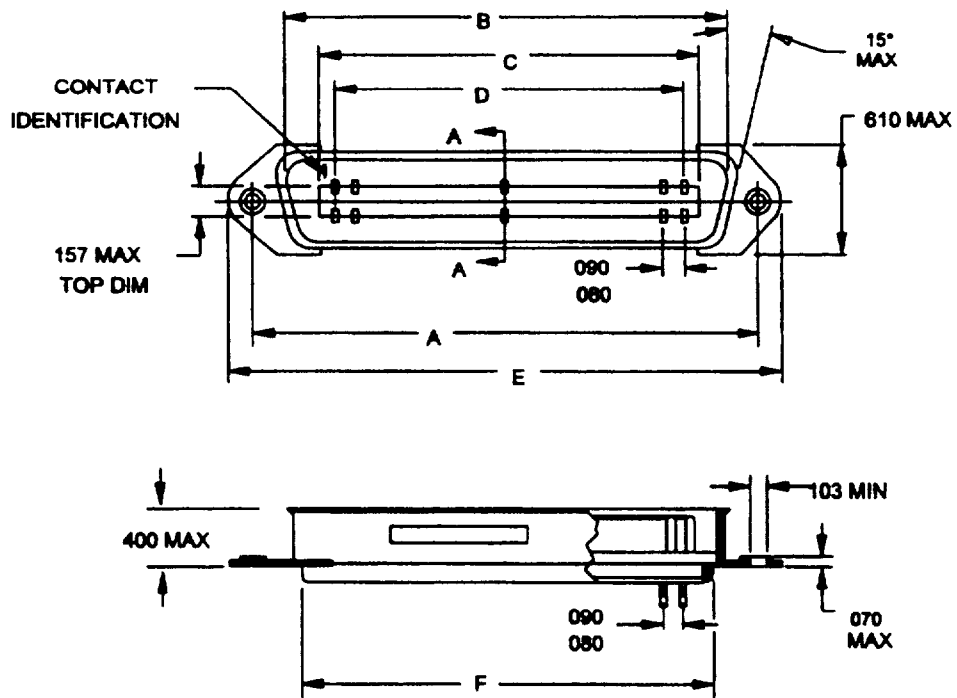
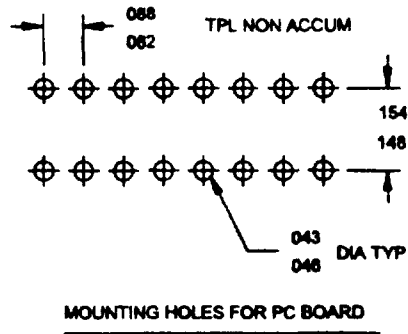
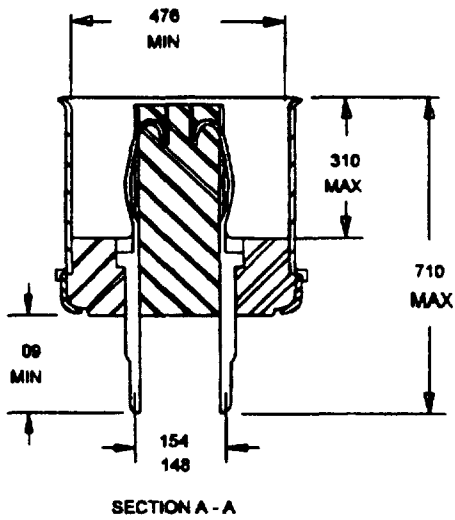

Figure 1. Dimensions and configurations

A-A-55532



MM	INCH	MM	INCH	MM	INCH
1.09	.043	2.29	.090	7.62	.300
1.17	.046	2.62	.103	10.16	.400
1.52	.060	3.73	.147	12.09	.476
2.03	.080	3.89	.153	15.49	.610
2.08	.082	3.99	.157	17.78	.700
2.24	.088				

Size	A		B	C	D		E Max	F Max
	Min	Max	Min	Max	Min	Max		
14	35.86 (1.412)	36.12 (1.422)	25.43 (1.001)	17.53 (.683)	12.83 (.506)	13.08 (.515)	44.45 (1.750)	23.11 (.910)
24	46.66 (1.837)	46.91 (1.847)	36.32 (1.430)	28.14 (1.108)	23.62 (.930)	23.88 (.940)	52.24 (2.175)	33.91 (1.335)
36	59.61 (2.347)	59.87 (2.357)	49.05 (1.931)	41.10 (1.618)	36.58 (1.440)	36.83 (1.450)	68.20 (2.865)	46.86 (1.845)
50	74.73 (2.942)	74.98 (2.952)	64.29 (2.531)	56.21 (2.213)	51.69 (2.035)	51.94 (2.045)	83.21 (3.280)	61.98 (2.440)

NOTES-

1. Dimensions are in millimeters.
2. Inches are in parentheses.
3. This item was designed using inch-pound units of measurement. In case of problems involving conflicts between the metric and inch-pound units, the inch-pound units shall rule.
4. All dimensions are after plating.

Figure 1 Dimensions and configurations - Continued

A-A-55532

TABLE II. Mating connector.

Plug dash number	Mating connector	Mating connector	Mating connector
01	AA55529-01	AA55531-01	AA55533-01
02	AA55529-02	AA55531-02	AA55533-02
03	AA55529-03	AA55531-03	AA55533-03
04	AA55529-04	AA55531-04	AA55533-04

TABLE III. Dash number.

Dash number	Number of contacts
01	14
02	24
03	36
04	50

4. Regulatory requirements. This section is not applicable to this CID.

5. Quality assurance provisions.

5.1 Responsibility for inspection. Unless otherwise specified in the contract or purchase order, the contractor is responsible for the performance of all inspection, examination, and test requirements specified herein. Except as otherwise specified in the contract or purchase order, the contractor may use his own or any other facilities suitable for the inspection requirements specified herein, unless disapproved by the Government. The Government reserves the right to perform any of the inspections, examinations, or tests set forth in this description where such inspections, examinations, and tests are deemed necessary to assure supplies and services conform to prescribed requirements.

5.2 Contractor certification statement. The contractor shall certify and maintain objective quality evidence that the product offered meets the requirements of this CID, and that the product conforms to the producer's own drawings, specifications, standards, quality assurances practices, and is the same as the product provided as a bid sample. The Government reserves the right to require proof of such conformance prior to the first delivery and thereafter as may be otherwise provided for under the provisions of the contract.

5.3 Certificate of compliance. A certificate of compliance shall accompany all connectors supplied to this CID.

6. Packaging.

6.1 Preservation, packaging, packing, labeling, and marking. Preservation, packaging, labeling, and marking shall be as specified in the contract or purchase order

7. Notes

7.1 PIN The PIN should be used for government purposes to buy commercial products to this CID. See 2.1 for PIN format

7.2 Government users. To acquire information on obtaining these connectors from the Government inventory system, contact Defense Electronics Supply Center, ATTN DESC-EON, 1507 Wilmington Pike, Dayton, OH 45444 5522, or telephone (513) 296-5009

A-A-55532

7.3 Ordering data. Acquisition documents should specify the following:

- a. CID document number and revision and CID PIN
- b. Quality assurance provisions.
- c. Packaging requirements.

7.4 Suggested sources of supply. A suggested source of supply is listed in table I. Additional sources will be added as they become available.

TABLE IV. Suggested source of supply.

CID PIN AA55532-	Vendor commercial PIN CAGE 71785
01	57-10140-4
02	57-10240-3
03	57-10360-13
04	57-10500-27

Supersession data: See table V.

TABLE V. Supersession data.

New part number	Superseded part number
AA55532-**	M83515/5-**

Vendor CAGE  
number

71785

Vendor name  
and addressCINCH CONNECTORS  
1500 Morse avenue  
Elk Grove village, IL 60007CIVIL AGENCY COORDINATING ACTIVITY:  
GSA - 7FXEPREPARING ACTIVITY:  
DLA-ES

(Project 5935-D549)