

**INCH-POUND**  
**A-A-55305**  
**January 27, 1997**

## COMMERCIAL ITEM DESCRIPTION

### TAG, IDENTIFICATION, PERSONNEL

The General Services Administration has authorized the use of this commercial item description as a replacement for MIL-T-842 for all Federal agencies.

1. **SCOPE.** This document covers one type of metal identification tag used by personnel of the Armed Forces for identification purposes.
2. **SALIENT CHARACTERISTICS.** The identification tag shall be constructed from corrosion-resisting steel with a natural finish conforming to class 304, condition A, HR, or CR, finish No. 1 of ASTM A 666. At any point on the flat more than 1/8 inch from the beaded edge, the finished tag shall have a maximum hardness of 179 on the Diamond Pyramid hardness scale when tested in accordance with ASTM E 92 or 88 on the Rockwell 15 T scale when tested in accordance with ASTM E 18. The tag shall be 2.000 (+.005, -.020) inches long by 1.125 (+.003, -.025) inches wide with rounded edges (.75 RAD). The tag shall have a  $.141 \pm .005$  inch diameter hole with the center of the hole located  $.156 \pm .005$  inch from one edge. The thickness of the tag shall be  $.016 \pm .001$  inch, and the thickness of the bead around the edge and hole shall be  $.0315 (+.0225, -.0025)$  inch. (See Figure 1.)
3. **REGULATORY REQUIREMENTS.** The offeror/contractor is encouraged to use recovered materials to the maximum extent practicable, in accordance with paragraph 23.403 of the Federal Acquisition Regulation (FAR).
4. **QUALITY ASSURANCE PROVISIONS**
  - 4.1 **Product conformance.** The products provided shall meet the salient characteristics of this commercial item description, conform to the producer's own standards and quality assurance practices, and be the same product offered for sale in the commercial market. The Government reserves the right to require proof of such conformance.
  - 4.2 **Visual examination.** Each tag shall be examined for the defects listed below.

**Beneficial comments, recommendations, additions, deletions, clarifications, etc. and any data which may improve this document should be sent to: Defense Personnel Support Center, Clothing and Textiles Directorate, Attn: DPSC-FNS, 2800 South 20th Street, Philadelphia, PA 19145-5099.**

AMSC N/A

FSC 8465

**DISTRIBUTION STATEMENT A.** *Approved for public release; distribution is unlimited.*

**A-A-55305**

4.2.1 **Defects.** Tag design not in accordance with specified requirements; finish not natural; finish oily or dirty, pitted, porous, crystalline, or open grained; crack, seam, lap, or other imperfections in finish; hole (other than specified) in finish; any rough surface or irregularity which may cause injury or discomfort to wearer; surface not smooth, malformed, bent, or otherwise damaged, preventing or effecting embossing or printing; any defect which renders tags unsuitable for immediate personal wear; not made of specified material; beaded edges and the rolled edge of the hole not on same side of tag; any dimension not within the specified tolerance; any items not packaged in accordance with the contract or purchase order.

4.3 **Acceptance criteria.** Acceptance criteria shall be as specified in the contract or purchase order.

**5. PACKAGING**

5.1 **Preservation, packing, and marking.** The preservation, packing, and marking shall be as specified in the contract or order.

**6. NOTES**

6.1 **Source of Government documents.** Copies of military and Federal documents are available from:

Standardization Documents Order Desk  
Bldg. 4D  
700 Robbins Avenue  
Philadelphia, PA 19111-5094

6.2 **Source of non-Government documents**

ASTM Test Methods

(Applications for copies should be addressed to American Society For Testing and Materials, 100 Barr Harbor Drive, West Conshohocken, PA 19428.)

**MILITARY INTERESTS:**

**Custodians**

Army - GL  
Navy - NU  
Air Force - 99

**CIVIL AGENCY COORDINATING ACTIVITY:**

GSA - FSS

**Review Activities**

Army - MD  
Air Force - 45, 82  
Navy - MC

**PREPARING ACTIVITY:**

DLA - CT

**Project 8465-0233**

### A-A-55305

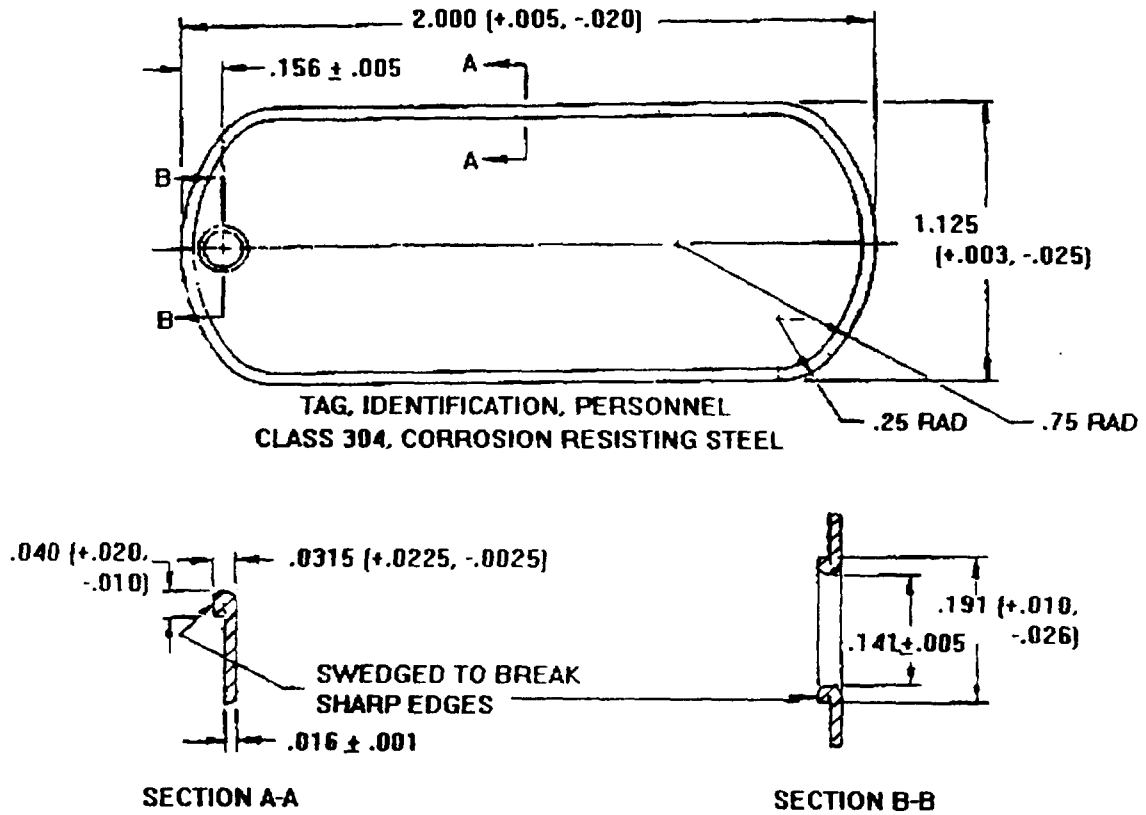

UNLESS OTHERWISE SPECIFIED  
DIMENSIONS ARE IN INCHES

FIGURE 1. TAG, IDENTIFICATION PERSONNEL