

[INCH-POUND]  
A-A-52558  
February 20, 1996  
SUPERSEDING  
MIL-B-385G  
25 November 1985

## COMMERCIAL ITEM DESCRIPTION

BREAKERS, PAVING, PNEUMATIC-POWERED;  
(0.875 INCH HEXAGON BY 3.25 INCH CHUCK)

The General Services Administration has authorized the use of this commercial item description (CID) for all federal agencies.

1. SCOPE. This CID covers a 35 pound (lb) [16 kilograms (kg)] pneumatic-powered, paving breakers intended for use in breaking up concrete, brick, macadam pavement, loosening compacted gravel and stiff clay.

2. CLASSIFICATION. The pneumatic-powered paving breakers shall be of two types.

2.1 Types. Type I utilizes a D-grip handle, and Type II utilizes a T-handle.

### 3. SALIENT CHARACTERISTICS

3.1 Description. The length of the pneumatic paving breaker (herein referred to as "breaker"), for Type I and Type II breakers, less attachment, shall not be more than 21 inches (in.) and 31 inches [573 millimeters (mm) and 787 mm] respectively. Each type of breaker shall consist essentially of a backhead equipped with a handle and trigger throttle, and a cylinder with chuck and fronthead. At 90 pounds per square gage (psig) [621 kilopascals (kPa)], the total air consumption of the breaker shall not exceed 46 cubic feet per minute (cfm). The breaker design and construction shall be representative of a standard commercial paving breaker with a history of durability and performance, which also meets the requirements of this CID.

Beneficial comments, recommendations, additions, deletions clarifications, etc. and any other data which may improve this document should be sent to: U.S. Army Tank-automotive and Armaments Command, ATTN: AMSTA-TR-E/BLUE, Warren, MI 48397-5000.

FSC 3820

DISTRIBUTION STATEMENT A. Approved for public release: distribution is unlimited.

A-A-52558

3.2. Materials. The materials used for the breaker shall be produced to comply with the requirements and provisions of this CID. The breaker shall be fabricated from compatible materials that are inherently corrosion resistant or treated in order to provide protection against the various forms of corrosion and deterioration. Dissimilar metals shall not be used in intimate contact with each other unless protected against galvanic corrosion. Recovered materials shall be used to the maximum extent practicable. Materials not specified shall be selected by the contractor and shall be subject to all provisions of this CID. Asbestos, cadmium, and radioactive material will not be used in this item. Radioactive material is defined by 1) Title 10, Code of Federal Regulations, Part 40, and 2) Other radioactive material in which the radioactivity is greater than 0.002 microcuries per gram or 0.01 microcuries total activity for the item.

3.3. Performance. The force of blow of the breaker shall be not less than 9 foot-pounds (ft-lb) (12.20 Newton-meters (N-m)) per blow under vertical operating conditions with no extra force applied on top of the breaker. The piston speed at no load shall be not less than 1800 blows per minute. The breaker shall break a 2 in. (51 mm) or thicker slab of Portland cement concrete. The breaker using the spade in cohesive soil shall operate in all positions from the vertical to the horizontal. The breaker shall accomplish the tasks without evidence of mechanical failure, malfunction, permanent deformation, breakage of any part or component, evidence of wearing of the piston diameter or cylinder diameter of more than 0.001 in. (0.0254 mm), absence of oil vapor in the exhaust air and failure to break the slab of Portland cement concrete. Performance shall be unimpaired at any ambient temperature from -25 degrees Fahrenheit (°F) to 120°F [-32 degrees Celsius (°C) to 49°C].

#### 3.4 Maintainability and reliability.

3.4.1 Maintenance support. Technical manuals, illustrating repair parts and recommended operation and scheduled maintenance, shall be furnished with each breaker. All repair parts having the same part number shall be functionally and dimensionally interchangeable.

3.5 Surfaces. All edges shall be rounded or chamfered, and all parts, components, and assemblies of the breaker including surfaces shall be clean, and free from sand, dirt, firs, pits, sprues, scale and other harmful or extraneous materials.

3.6 Noise limits. Noise levels shall not exceed 85 decibels [dB(A)] at operating positions during typical load operations. If it can be shown that 85 dB(A) is beyond the state of the art for this equipment, then a hearing protection warning decal shall be placed on the equipment stating that hearing protection is required within (specify) feet. The distance specified shall be the greatest distance at which 85 dB(A) is met. The decal shall be readable to all personnel exposed to the hazard. Warnings shall also be added to applicable manuals requiring hearing protection to be worn within the specified distance.

3.7 Backhead assembly. The backhead assembly shall include a housing, handle, throttle, and throttle valve. The handle for type I shall be D-grip and for type II shall be extension T-handle. The throttle for type I shall be positioned inside the D-grip. The throttle shall be located for operating from either side of the breaker by the operator. A self-closing lever type throttle shall be furnished.

3.8 Cylinder assembly. The cylinder assembly shall include a cylinder, valve mechanism, piston, and chuck. The valve mechanism shall control the direction of the air to the piston. The piston shall be a combination piston-hammer. The chuck shall be dimensioned to receive standard accessories having collared hexagon shanks 0.875 in. (22 mm) across the flats by 3.25 in. (83.0 mm) (see Figure 1). The chuck bushing shall be replaceable. An air cushion of not less than 0.003 in. (0.08 mm) at both ends of the piston stroke shall be furnished.

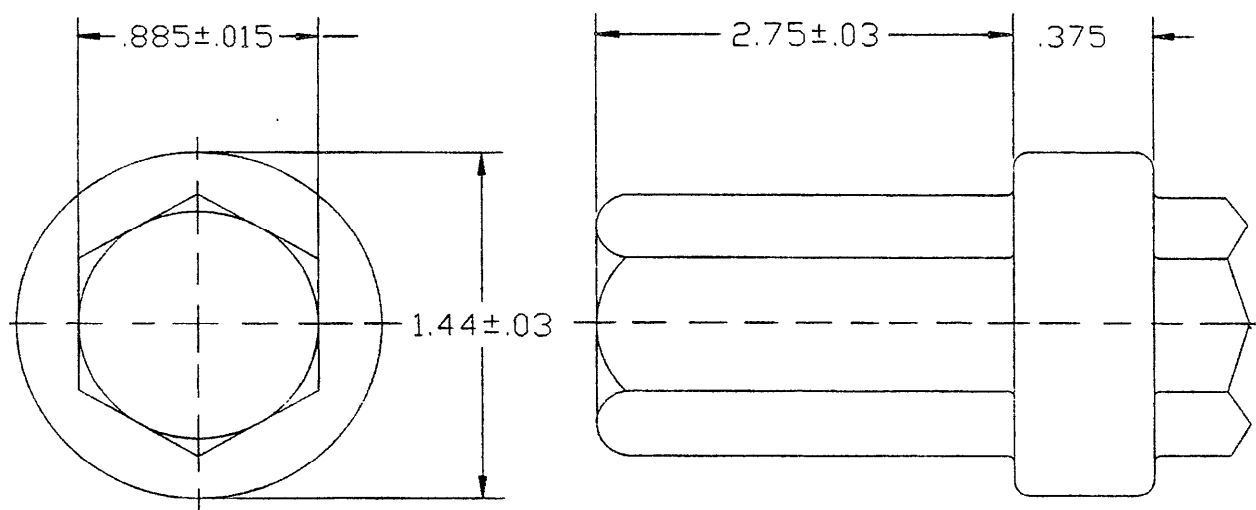

FIGURE 1. Shank dimensions.

3.9 Leader hose. Unless otherwise specified (see 7.3), a 10 foot-long, 0.5 in. inside diameter hose (3 meters long, 13 mm inside diameter) shall be furnished with an external 1/2 -14 NPT connector with a double bolt clamp on one end and a 0.5 in. (13 mm) coupling half quick disconnect with male hose fitting with a size 1, pneumatic hose clamp conforming to SAE J536B on the other end.

3.10 Air inlet connection. The air inlet connection thread shall be 1/2 in. internal American National pipe thread. The air inlet connection shall be a swivel type connection to allow the operator to position the hose without any tangling or pinching.

A-A-52558

3.11 Exhaust port.The exhaust port shall be located to direct exhaust air away from the operator.

3.12 Accessories. When specified (see 7.3), the accessories listed below shall be furnished with the breaker. A latch type retainer shall be provided to prevent any accessory from becoming accidentally disengaged.

TABLE I. Accessory dimensions

Accessory	Length under collar (in.)	Tool end (in.)
Chisel	13.5 to 14.5	2.75 to 3.25 wide
Moil point	13.5 to 14.5	Point
Pitch	16 to 19	3 to 3.25 wide
Spade	16 to 19	5 to 6 wide

3.13 Lubrication. AH surfaces requiring lubrication shall be provided with a means for lubricating by an airline oiler. The oiler shall have the contractors standard commercial finish, which shall be smooth even surface, free from runs, sags or foreign material The type of pneumatic system grease used for lubrication is identified by NATO Code Number G392.

3.14 Identification and marking. Identification and markings shall be permanent, legible and shall include as a minimum the Manufacturer's identification code (CAGE), the Part or Identifying Number (PIN), and the National Stock Number (NSN).

3.15 Treatment and painting. The portion of the breaker and its components and parts normally painted shall be cleaned, treated, and painted for a one coat finish. The color shall conform to FED-STD-595, camouflage green 383 chip color 34094.

3.16 Chest. Unless otherwise specified (see 7.3), a chest made of steel or a material of equivalent strength not less than 0.07 in. (4 mm) in thickness shall be provided to hold the breaker, repair parts, and any accessories provided with the breaker. The chest shall have a continuous hinge extending the full length of the chest edge. The chest lids shall be held closed by not less than two hook type tension latches. A hose and lock shall be provided with the chest. Two lifting handles shall be provided, one located at each end of the chest.

3.17 Retainer. Each breaker shall be provided with a retainer that will prevent the accessory tool from becoming accidentally disengaged from the breaker. All surfaces that are subject to high temperatures shall be covered or guarded.

4. REGULATORY REQUIREMENTS. The offeror/contractor is encouraged to use recovered materials to the maximum extent practicable, in accordance with paragraph 23.403 of the Federal Acquisition Regulation (FAR).

#### 5. QUALITY ASSURANCE PROVISIONS

5.1 Contractor certification. The contractor shall certify and maintain substantiating evidence that the product offered meets the salient characteristics of this CID and that the product conforms to the producer's own drawings, specifications, workmanship standards, and quality assurance practices. Items with known defects shall not be submitted for Government acceptance. The Government reserves the right to require proof of such conformance prior to the first delivery and thereafter as maybe otherwise provided for under the provisions of the contract.

6. PACKAGING. Preservation, packing, and marking shall be as specified in the contractor order (see 7.3).

7. NOTES (This section contains information of a general or explanatory nature that may be helpful, but is not mandatory.)

7.1 Government documents. Copies of the FED-STD-595 "Colors Used in Government Procurement" are available from the Standardization Document Order Desk, 700 Robbins Avenue, Building 4D, Philadelphia, PA 19111-5094.

7.2 Non-Government documents. Copies of SAE J536B "Hose Clamp Standards" are available from the Society of Automotive Engineers, 400 Commonwealth Dr., Warrendale, PA 15096.

7.3 Ordering data. Acquisition documents must specify the following:

- a. Title, number, and date of this CID.
- b. Type required.
- c. Issue of Department of Defense Index of Specifications and Standards (DoDISS) to be cited in the solicitation.
- d. PIN number and quantity required.
- e. Applicable level of preservation, packing, and marking.
- f. When a leader hose is not to be furnished.
- g. Accessories required.
- h. When a chest is required.

A-A-52558

7.4 Part or identification number (PIN) The PIN's to be used for breakers acquired to this CID are created as follows:

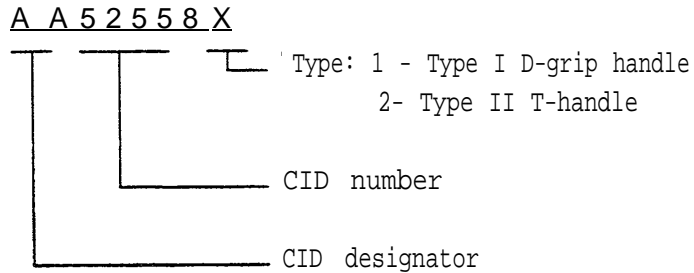

7.5 Cross-reference data. Pneumatic powered paving breakers conforming to this CID are interchangeable/substitutable with breakers of the same part number conforming to MIL-B-385G.

7.6 Federal regulations. The Code of Federal Regulations (CFR) maybe obtained from Superintendent of Documents, U.S. Government Printing office, Washington, DC 29492.

MILITARY INTERESTS:

Custodians:

Army - AT  
Air Force -99

Review activities:

Air Force -84  
DLA - CS

CIVIL AGENCY COORDINATING ACTIVITY:

GSA - FSS

PREPARING ACTIVITY:

Army - AT

(Project 3820-0006)