

[INCH-POUND]
A-A-52506B
August 16, 1996
SUPERSEDING
A-A-52506A
April 28, 1995

COMMERCIAL ITEM DESCRIPTION

CLAMPS, HOSE

The General Services Administration has authorized the use of this commercial item description (CID) for all Federal Agencies.

1. SCOPE

1.1 Scope. This CID covers metal hose clamps that are used for holding flexible ducts, or hose on to a male fitting. These hose clamps are generally used on coolant, fuel, oil, vacuum, and emission systems. The selection of type and size of hose clamps for a specific application involves factors, such as torque, vibration, and pressure requirements (see 5.4).

1.2 Classification. Hose clamps are classified by types as specified in SAE J1508 and illustrated in figure 2 for ease of reference. The type and size of hose clamps are predicated on application requirements. Refer to SAE J1508 for availability of size for each type of hose clamps (see 5.2).

2. SALIENT CHARACTERISTICS

2.1 Material. Unless otherwise specified herein, hose clamp materials and finishes, including screws and other hardware, shall be as specified in SAE J1508. The use of recovered material made in compliance with regulatory requirements is acceptable providing that all requirements of this CID are met (see 5.5).

2.1.1 Finish. Components of hose clamps which are not made of inherently corrosion resistant materials shall be zinc plated and subjected to an embrittlement relief treatment.

Beneficial comments, recommendations, additions, deletions, clarifications, etc. and any other data which may improve this document should be sent by letter to: U.S. Army Tank-automotive and Armaments Command, ATTN: AMSTA-TR-E/BLUE, Warren, MI 48397-5000.

ASMC N/A

FSC 4730

DISTRIBUTION STATEMENT A. Approved for public release; distribution is unlimited.

A-A-52506B

2.2 Design, construction, and performance. Unless otherwise specified herein, the clamp design, construction, and performance of hose clamps shall be in accordance with SAE J1508. Clamp component parts shall remain as an assembly during installation and removal of the clamp.

2.2.1 Band length. The maximum overlap band length at the maximum of the hose diameter for type F, I, and M clamps shall be as specified in figure 1 and shall be verified when subjected to salient characteristic 2.2.2. Metric measurements are noted in parenthesis (millimeter).



FIGURE 1. Band length.

2.2.2 Clamping diameter verification. To verify the clamping diameter the hose clamps shall be assembled over and close tight upon round mandrels of diameters equal to the corresponding open and closed diameters specified in the dimensional tables in SAE J1508. Diameters smaller than closed diameters shown are allowable. Hose clamps shall meet the open diameter required with all threads engaged.

2.2.3 Torque. The hose clamp torque requirements shall conform to SAE J1508 for the appropriate type and size required.

2.2.4 Sealing capability. SAE J1610 shall be used to evaluate the pressure, vibration, and temperature (PVT) sealing capabilities of type F hose clamps.

2.3 Identification and marking. Unless otherwise specified (see 5.2), the hose clamps shall be identified or marked in a legible and permanent manner with the type, size, and manufacturer's name or trademark. When required (see 5.2), the marking on small clamp sizes shall be placed on the outside of the box.

3. QUALITY ASSURANCE PROVISIONS

3.1 Responsibility for inspection. The contractor is responsible for the performance of all inspections (examinations and tests).

A-A-52506B

3.2 Product conformance. The products provided shall meet the salient characteristics of this commercial item description, conform to the producer's own drawings, specifications, standards, and quality assurance practices, and be the same product offered for sale in the commercial market. The Government reserves the right to require proof of such conformance.

4. PRESERVATION, PACKAGING, PACKING, LABELING, AND MARKING

Preservation, packaging, packing, labeling, and marking for the desired level shall be as specified in the contract or order (see 5.2).

5. NOTES

(This section contains information of a general or explanatory nature that may be helpful, but is not mandatory.)

5.1 Addresses for obtaining copies of referenced documents. Copies of SAE J1508 "Hose Clamp Specifications (DoD Adopted)", and SAE J1610 "Test Method for Evaluating the Sealing Capability of Hose Connections with a PVT Test Facility" are available from the Society of Automotive Engineers, Inc. (SAE), 400 Commonwealth Drive, Warrendale, PA 15096-0001.

5.2 Ordering data. Acquisition documents must specify the following:

- a. Title, number, and date of this CID.
- b. Issue of the Department of Defense Issue of Specifications and Standards (DODISS) to be cited in the solicitation, and if required, the specific issue of individual documents referenced.
- c. Hose clamp type and size in accordance with SAE J1508.
- d. Selection of applicable level and packaging requirements.
- e. If hose clamp marking is required.
- f. Small clamps, marking is acceptable on the box only.

5.3 Cross reference data. Hose clamp types and sizes conforming to this CID are interchangeable/substitutable with hose clamp types and sizes conforming to WW-C-440B and MS35842E, as shown in table II. MS35842E part numbers are already cross referenced to the SAE sizes for type F hose clamps. WW-C-440B hose clamps are designated in accordance with SAE J1508 hose clamp types.

A-A-52506B

TABLE II. Cross reference data.

SAE J1508/CID A-A-52506 Hose Clamp Type(s)	Superseded WW-C-440B Hose Clamp Type(s)
A, AHH & SLA	A
B	B
C	C
D	D
E, CTB, CTW	E
F, FE, FEO, HD, I, M, MX, SLF, SLHD & T	F, MS35842E
NOT APPLICABLE (N/A)	G
N/A	H
TB, SLTB	N/A

5.4 Clamp types. The clamp types shown in figure 2 are for illustration purposes only. Refer to SAE J1508 for a more accurate depiction of the hose clamp types.

5.5 Regulatory requirements. The offeror/contractor is encouraged to use recovered materials in accordance with Public Law 94-580, as amended, to the maximum extent practicable.

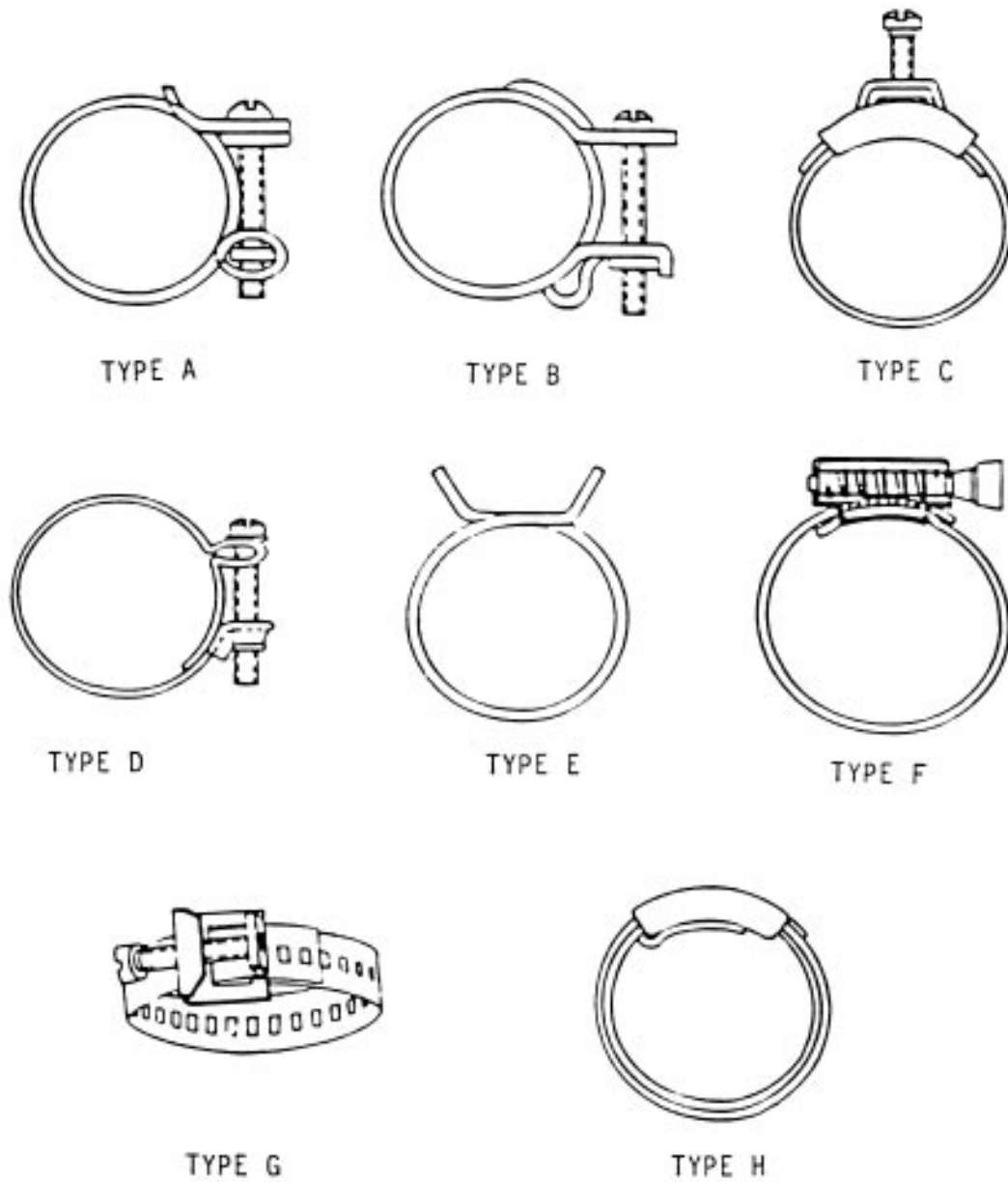

FIGURE 2. Referenced clamp types.

A-A-52506B

MILITARY INTERESTS

Custodians:

Army - AT
Navy - YD1
Air Force - 99

Review Activities:

Army - AR, AV, GL, ME, MI
Navy - CG, CM, MC, OS, SH
Air Force - 11, 82, 84, 85
DLA - CS

CIVIL AGENCY COORDINATING ACTIVITIES:

DC Govt - DCG
GSA - FSS
HSS - FEC
NASA - NA

Preparing Activity:

Army - AT

(Project 4730-0586)