

INCH-POUND

A-A-52431A

10 February, 2011

SUPERSEDING

A-A-52431(AT)

February 18, 1993

## COMMERCIAL ITEM DESCRIPTION

## EVAPORATOR, ALCOHOL - AIR BRAKE SYSTEM

The General Services Administration has authorized the use of this commercial item description (CID) as a replacement for MS53067B(AT), which is canceled.

1. **SCOPE.** This CID covers an alcohol evaporator used in air brake systems. The evaporator provides a means of inducing filtered air through the alcohol to form vapor for induction into the air compressor and brake system. The alcohol evaporator is also referred to herein as evaporator.

## 2. SALIENT CHARACTERISTICS

2.1 **Material.** The material used to make the evaporator shall be compatible with commercial grade methyl alcohol (methanol) and shall be corrosion resistant or treated to resist corrosion. Cadmium plating is not acceptable. The container shall be made of shatter resistant material. The use of recovered material made in compliance with regulatory requirements is acceptable providing that all requirements of this CID are met (see 3).

2.2 **Design and construction.** The assembly shall be constructed so that no part will work loose in service and shall be built to withstand the strains, jars, vibrations and other conditions in shipping, storage, installation service, and environment. The configuration and dimensions of the evaporator are not limited to the construction features other than as shown in figure 1.

2.2.1 **Container capacity.** The fluid capacity of the container shall be approximately one pint and shall be detachable by means of a glass jar type screw thread.

2.3 **Performance.**

2.3.1 **Working temperature.** The evaporator shall be operable in ambient temperatures of -35 to +120 degrees Fahrenheit (°F).

Beneficial comments, recommendations, additions, deletions, clarifications, etc. and any data that may improve this document should be sent to [DAMI\\_STANDARDIZATION@conus.army.mil](mailto:DAMI_STANDARDIZATION@conus.army.mil) or U.S Army RDECOM, Tank Automotive Research, Development and Engineering Center, ATTN: RDTA-EN/STND/TRANS MS #268, 6501 E. 11 Mile Road, Warren, MI 48397-5000. Since contact information can change, you may want to verify the currency of this address information using the ASSIST Online database at <https://assist.daps.dla.mil>.

A-A-52431A

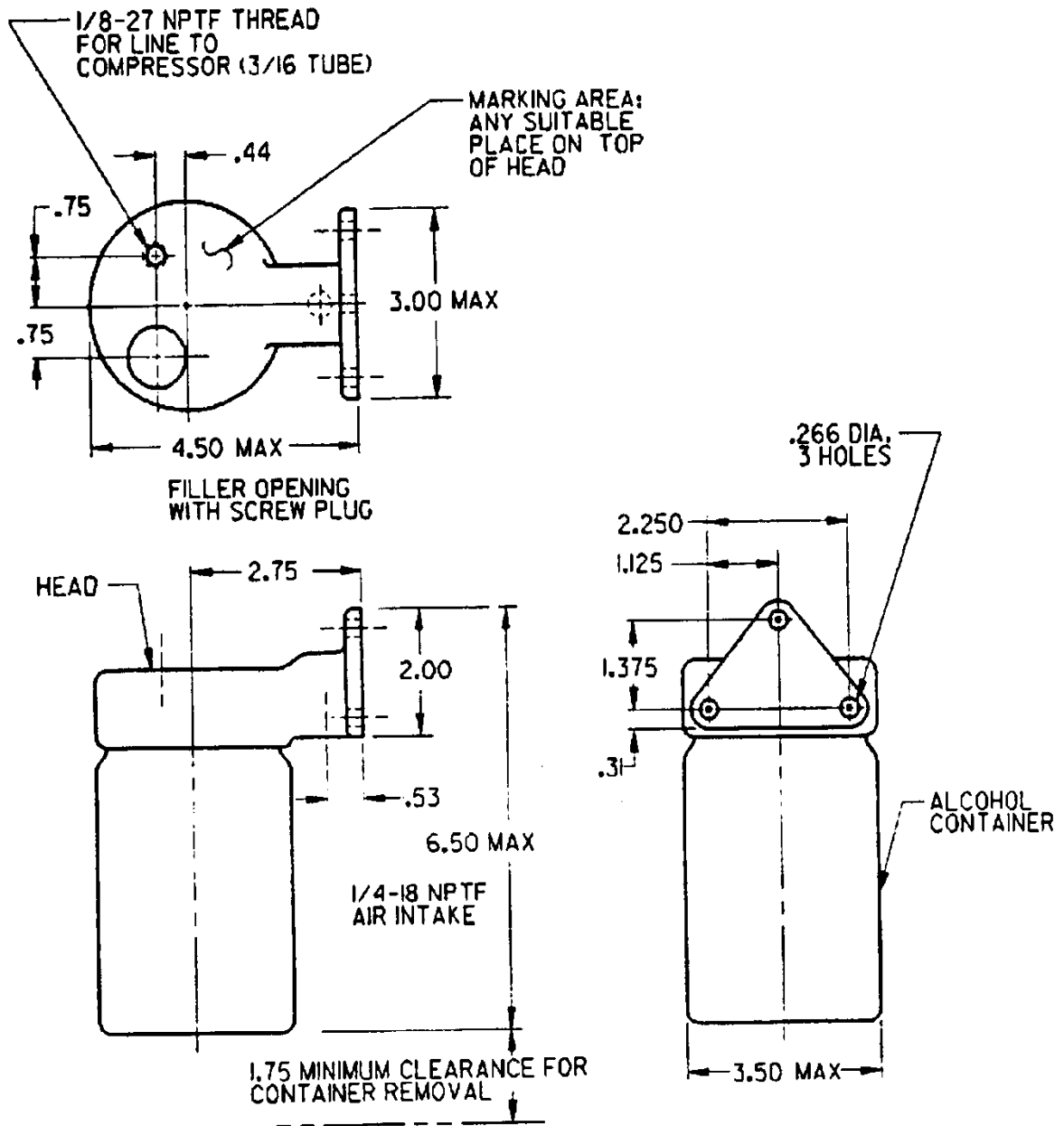

Part identification number (PIN)	Former MS part number	Former part number
A52431-1	MS53067-1	8399169

NOTE: Dimensions are in inches. Unless otherwise specified, tolerances on decimals are: Two places  $\pm .06$ , three places  $\pm .005$ .

FIGURE 1. Evaporator assembly.

## A-A-52431A

2.3.2 Rate of evaporation. The evaporator shall meter the methanol vapor into the compressor intake at a rate of .1 to .5 cubic centimeters (cm<sup>3</sup>) of alcohol per cubic feet per minute (CFM) of free air delivered by the compressor.

2.4 Air intake. The evaporator shall have a threaded air intake for attachment of a deep water fording kit (see figure 1).

2.5 Identification and marking. Identification and marking shall be permanent and legible and, as a minimum, shall include the part identification number (PIN) A52431-1 (see 6.1), the manufacturer's CAGE code (or equivalent identification) and part number (see figure 1).

2.6 Workmanship. The workmanship shall be such as to ensure a product free of sharp edges, burrs, or any other defects which may affect the items serviceability or appearance.

3. REGULATORY REQUIREMENTS. The offeror/contractor is encouraged to use recovered materials to the maximum extent practicable, in accordance with paragraph 23.403 of the Federal Acquisition Regulation (FAR).

#### 4. PRODUCT CONFORMANCE PROVISIONS

4.1 Responsibility for inspection. The contractor is responsible for the performance of all inspections (examinations and tests).

4.2 Contractor certification. The contractor shall certify and maintain substantiating evidence that the product offered meets the salient characteristics of this commercial item description and that the product conforms to the producer's own drawings, specifications, standards, and quality assurance practices. Items with known defects shall not be submitted for Government acceptance. The Government reserves the right to require proof of such conformance prior to the first delivery and thereafter as may be otherwise provided for under the provisions of the contract.

5. PACKAGING. Preservation, packaging, packing, labeling, and marking for the desired level shall be as specified in the contract or order (see 6.1).

#### 6. NOTES

(This section contains information of a general or explanatory nature that may be helpful, but is not mandatory.)

6.1 Ordering data. Acquisition documents must specify the following:

- a. Title, number, and date of this commercial item description.
- b. Issue of Department of Defense Index of Specifications and Standards (DODISS) to be cited in the solicitation.
- c. PIN number and quantity required (see 2.5).
- d. Selection of applicable level and packaging requirements (see 5).

A-A-52431A

6.2 Cross-reference data. Evaporators conforming to this CID are interchangeable/substitutable with evaporators conforming to MS53067B, dated 6 March 1970 (see figure 1).

6.3 Metric product. Evaporators manufactured to metric dimensions will be considered on the following basis:

- a. Products manufactured to metric dimensions will be considered on an equal basis with those manufactured using inch-pound units, provided they fall within specified tolerances using conversion tables contained in the latest revision of IEEE/ASTM SI10, and all other requirements of this CID are met.
- b. If a product is manufactured to metric dimensions and those dimensions exceed the tolerances specified in the inch/pound units, a request should be made to the contracting officer to determine if the product is acceptable.
- c. The contracting officer has the option of accepting or rejecting the product.

6.4 Key words.

methyl alcohol  
methanol

Custodian:  
Army - AT

Review activities:  
Army - CR4  
DLA - CC

Preparing activity:  
Army - AT

(Project 2530-2010-001)

NOTE: The activities listed above were interested in this document as of the date of this document. Since organizations and responsibilities can change, you should verify the currency of the information above using the ASSIST Online database at <https://assist.daps.dla.mil>.