

INCH-POUND

A-A-52426A (AT)

21 May 2012

SUPERSEDING

A-A-52426 (AT)

10 February 1993

COMMERCIAL ITEM DESCRIPTION

HOSE AND HOSE ASSEMBLIES, NON-METALLIC, SILICONE, POLYESTER AND WIRE REINFORCED (FOR COOLANT AND HEATING SYSTEMS OF DIESEL AND GASOLINE POWERED ENGINES)

The General Services Administration has authorized the use of this commercial item description (CID) as a replacement for MIL-H-62217A(AT), MIL-H-62217/1A(AT), MIL-H-62217/2(AT), MIL-H-62217/3(AT) and MIL-H-62217/4(AT) which are canceled.

1.0 SCOPE. This CID covers polyester and wire reinforced, silicone compounded, elastomeric hose and hose assemblies, for coolant and heating systems of diesel and gasoline powered engines, with a temperature range from -40 degrees Fahrenheit (°F) to +425 °F. All hose types are intended for severe service such as on cars, buses, heavy duty military and commercial trucks, military combat vehicles, and off-road earth moving equipment. Type I (1/2 inch inside diameter (ID) thru 1 1/8 inch ID) hose is intended for connecting hot water heaters to coolant circulating systems of ground vehicles. The hose and hose assemblies described in this CID are hereinafter referred to as "hose".

2.0 CLASSIFICATION. Hose covered by this specification are classified as follows (see 6.3):

- Type I - Full tube ID for formed and beaded male tube ends on cooling and heater systems.
- Type II - Preformed full tube ID for formed and beaded male tube ends in cooling systems.
- Type III - A flexible type with cuff ID and outside diameter (OD) ends for clamping to formed and beaded male tube ends on cooling systems.
- Type IV - Full tube ID to accommodate reattachable fittings for sealed heater systems.

Beneficial comments, recommendations, additions, deletions, clarifications, etc. and any data that may improve this document should be sent to usarmy.detroit.rdecom.mbx.tardec-standardization@mail.mil or U.S. Army RDECOM, Tank Automotive Research, Development and Engineering Center, ATTN: RDTA-EN/STND/TRANS MS #268, 6501 E. 11 Mile Road, Warren, MI 48397-5000. Since contact information can change, you may want to verify the currency of this address information using the ASSIST Online database at <https://assist.dla.mil>.

AMSC N/A

FSC 4720

DISTRIBUTION STATEMENT A. Approved for public release; distribution is unlimited.

A-A-52426A

3.0 SALIENT CHARACTERISTICS.

3.1 Materials. The use of recovered materials made in compliance with regulatory requirements is acceptable providing that all requirements of this CID are met (see 6.6).

3.1.1 Inner tube. The inner tube shall be a high temperature resistant, silicone rubber conforming to the physical properties in table I.

3.1.2 Cover. Cover shall consist of a continuous layer of minimum thickness or a thin skin, wrapped layer of polysiloxane compounded elastomeric material conforming to the physical properties in table I.

3.1.3 Reinforcement.

3.1.3.1 Fabric (types I, II and IV). Reinforcement shall consist of multiple plies of woven or knitted fabric of such strength as to meet the requirements of this CID.

3.1.3.2 Wire (type III). Reinforcement shall consist of high carbon steel wire in accordance with SAE J20/2.

3.1.4 End fittings.

3.1.4.1 Preformed cuff (type III). The preformed cuff (soft end) end fitting shall be of silicone elastomeric plies, or fabric plies impregnated with silicone elastomeric material, with the physical properties in table I.

3.1.4.2 Steel (type IV). Steel end fittings, except stainless, shall be coated with alkaline zinc electroplate per ASTM B633 Class Fe/Zn 25 Type VI, or alkaline zinc nickel electroplate per ASTM B841 Class I Grade 8 with a minimum of 12 mass% nickel. The zinc or zinc nickel plating shall subsequently be coated with MIL-DTL-5541 Type II Class 1A.

3.2 Design and construction.

3.2.1 Type I. Hose type I as shown in figure 1 shall consist of an inner tube, an intermediate fabric reinforcement, and an outer cover or protective skin.

3.2.2 Type II. Hose type II as shown in figure 2 shall consist of an inner tube, an intermediate fabric reinforcement, and an outer cover or protective skin.

3.2.3 Type III. Hose type III as shown in figure 3 shall consist of an inner tube, a helical wire reinforcement (see 3.1.3.2), and an outer cover, and shall have a preformed cuff (see 3.1.4.1) on each end. Each cuff shall be of uniform thickness. Wire reinforcement shall not be exposed on either the inner or outer diameter of the hose. In addition, a fabric reinforcement may be used over the entire length of the hose.

A-A-52426A

3.2.4 Type IV. Hose type IV as shown in figure 4 shall consist of an inner tube, an intermediate fabric reinforcement and an outer cover or protective skin, with two steel end fittings attached, one male type and one female type.

TABLE I. Physical properties requirements.

| Physical properties | Types I, II, IV | | Type III | |
|--|-----------------|----------|------------|----------|
| | Inner Tube | Cover | Inner Tube | Cover |
| Original properties | | | | |
| Hardness, durometer, Shore A | 50/70 | N/A | 55/65 | N/A |
| Tensile strength, min, psi | 800 | 800 | 1000 | 1000 |
| Elongation, min, percent | 200 | 200 | 250 | 250 |
| Oven aging at temperatures noted, °F (72 hours) | 350±5 | 350±5 | 350±5 | 350±5 |
| Changes after 72 hours | | | | |
| Hardness, durometer, Shore A | -5 to +10 | 0 to +10 | 0 to +20 | N/A |
| Tensile strength retained, min, percent | 90 | 90 | 90 | 90 |
| Elongation retained, min, percent | 65 | 65 | 65 | 65 |
| Oil immersion (change) | | | | |
| Volume, max, percent (70 hours at 212 °F) | 0 to +40 | 0 to +40 | 0 to +40 | 0 to +40 |
| Tensile strength retained, min, percent | 60 | 60 | 60 | 60 |
| Hardness, durometer, Shore A, max | 0 to -20 | 0 to -20 | 0 to -20 | 0 to -20 |
| Coolant immersion (change) | | | | |
| Volume, max, percent (166 hours at 235±5 °F) | 0 to +10 | N/A | 0 to +10 | N/A |
| Hardness, durometer, Shore A | ±10 | N/A | ±10 | N/A |
| Tensile strength retained, min, percent | 70 | N/A | 70 | N/A |
| Elongation retained, min, percent | 75 | N/A | 75 | N/A |
| Compression set, maximum, percent | 35 | N/A | 35 | N/A |

NOTES: 1. "N/A" means "Note Applicable".
 2. "min" means "minimum".
 3. "psi" means "pounds per square inch".

3.2.4.1 Steel end fittings (type IV). Steel end fittings shall be in accordance with SAE J516 with the flares in table II. The female type shall incorporate a swivel. Fittings may be of the reusable type.

3.2.5 Woven or knitted fabric. Layers of fabric shall be well bonded with elastomeric silicone material which shall firmly join plies to inner tube and cover, and each other.

A-A-52426A

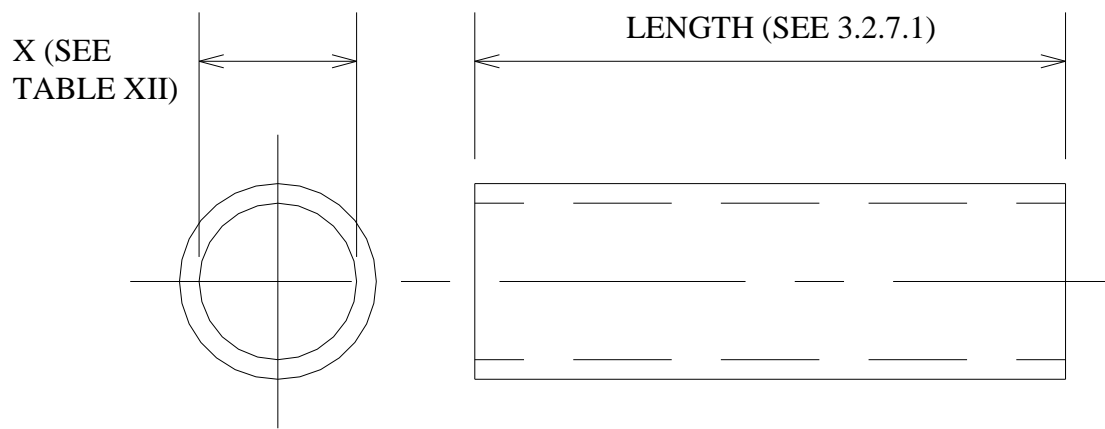

FIGURE 1. Type I hose.

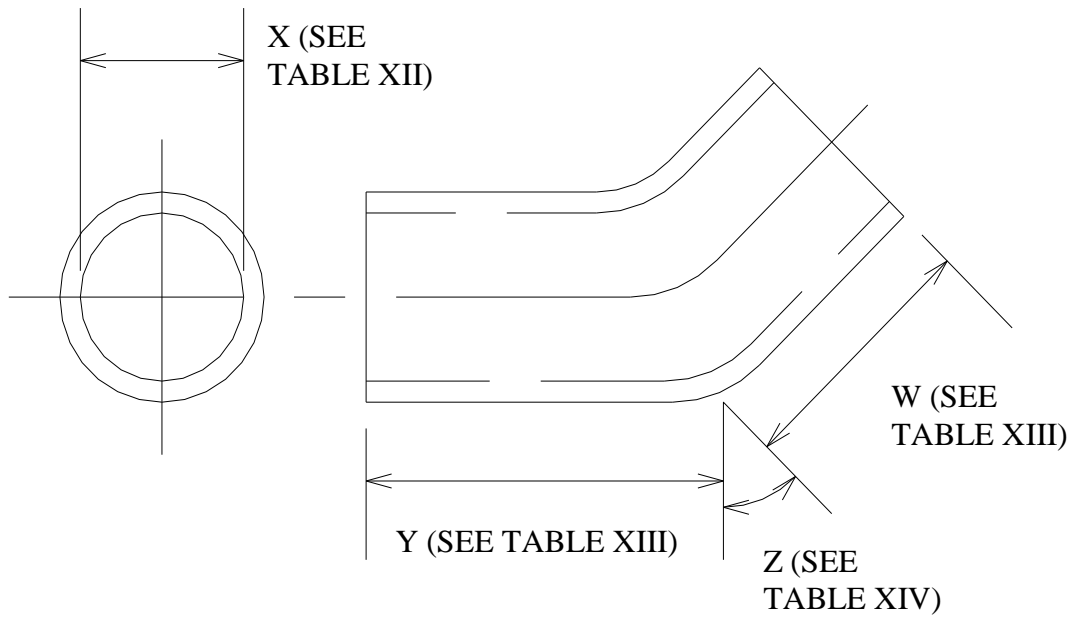
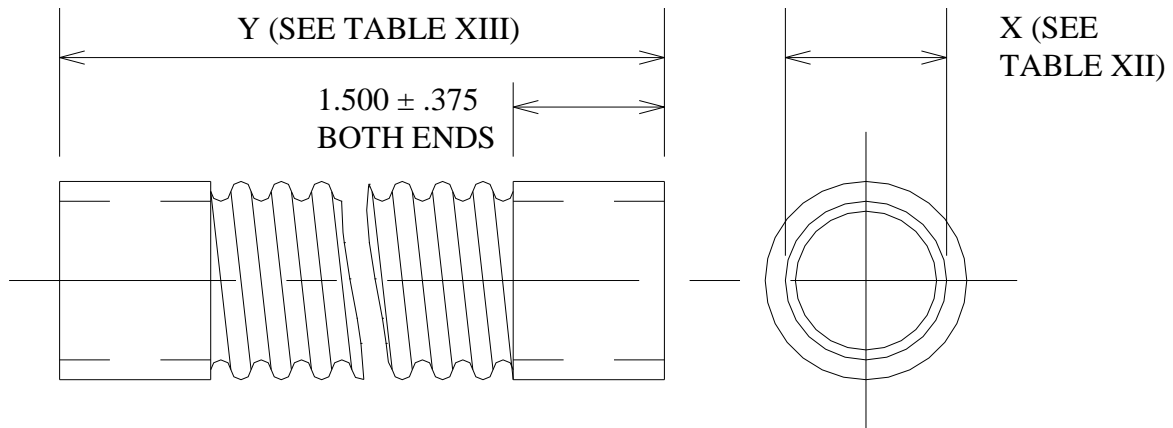

FIGURE 2. Type II hose.

A-A-52426A



NOTE: ALL DIMENSIONS IN INCHES

FIGURE 3. Type III hose.

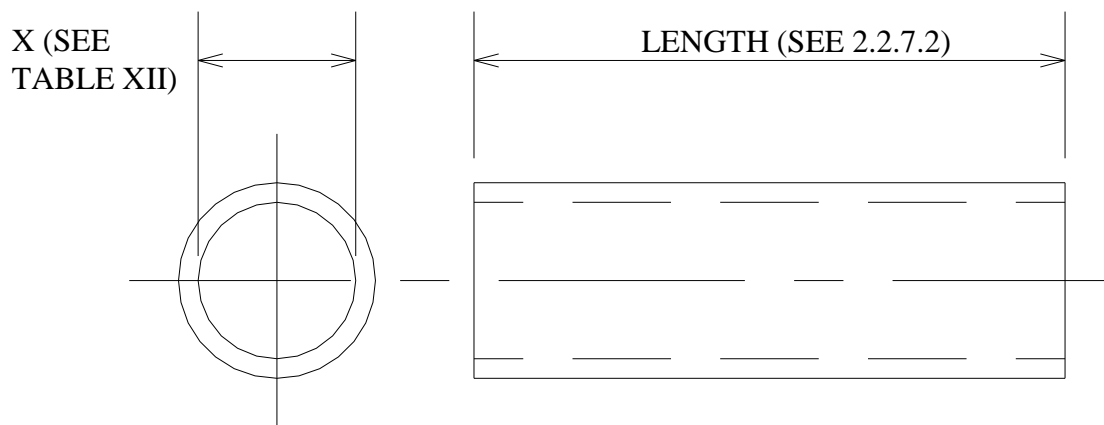

FIGURE 4. Type IV hose.

A-A-52426A

TABLE II. End fitting flares.

| End fitting flare | Type IV hose ID |
|-------------------|-----------------|
| 45° | .5 |
| 45° | .625 |
| 37° | .875 |
| 37° | 1.125 |

3.2.6 Dimensions.

3.2.6.1 Diameter tolerances. Tolerances for hose diameters shall be as shown in tables III, IV and V.

TABLE III. Hose diameter tolerances (types I and II).

| Inside diameter | | Tolerances | |
|-----------------|------------------|---------------|-------------|
| From | To and including | Straight hose | Curved hose |
| (inch) | (inch) | (inch) | (inch) |
| 3/8 | 1/2 | ±1/64 | ±1/32 |
| 5/8 | 4 | ±1/32 | ±1/32 |

TABLE IV. Hose diameter tolerances (type III).

| Inside diameter | | Outside diameter | |
|-----------------|-------------|------------------|-----------|
| (Hose & Cuff) | Tolerance | (Cuff only) | Tolerance |
| (inch) | (inch) | (inch) | (inch) |
| 1 1/4 | +1/64 -1/32 | 1 5/8 | +1/16 -0 |
| 1 1/2 | +1/64 -1/32 | 2 | +1/16 -0 |
| 1 3/4 | +1/64 -1/32 | 2 1/4 | +1/16 -0 |
| 2 | +1/64 -1/32 | 2 1/2 | +1/16 -0 |
| 2 1/4 | ±1/32 | 2 7/8 | +1/16 -0 |
| 2 1/2 | ±1/32 | 3 1/8 | +1/16 -0 |
| 3 | ±1/32 | 3 3/4 | +1/16 -0 |
| 4 | ±1/32 | 4 3/4 | +1/16 -0 |

3.2.6.2 Wall thickness. Types I, II, and IV hose wall thickness shall be within limits shown in tables VI and VII. Type III hose wall thickness shall be uniform and wire shall not be exposed.

3.2.6.3 Tolerance on lengths. Tolerances on types I, III, and IV for specified (cut) lengths shall be as specified in table VIII, and on type II hose (preformed) shall be as shown in table IX.

A-A-52426A

TABLE V. Hose diameter tolerances (types IV).

| Nominal Size I.D. (inch) | Inside diameter Tolerance (inch) |
|-----------------------------|-------------------------------------|
| 1/2 | +0.039 -0.000 |
| 5/8 | +0.042 -0.000 |
| 7/8 | +0.042 -0.000 |
| 1 1/8 | +0.047 -0.000 |

TABLE VI. Wall thickness limits (types I and II).

| Inside diameter | Minimum (inch) | Maximum (inch) |
|-----------------|----------------|----------------|
| All sizes | .170 | .220 |

TABLE VII. Wall thickness limits (type IV).

| Size (inch) | Minimum (inch) | Maximum (inch) |
|-------------|----------------|----------------|
| 1/2 | .144 | .166 |
| 5/8 | .144 | .166 |
| 7/8 | .142 | .168 |
| 1 1/8 | .155 | .177 |

TABLE VIII. Tolerance on hose lengths (types I, III, & IV).

| Over (inch) | To and including (inch) | Tolerance (inch) |
|----------------|-------------------------------|---------------------|
| -- | 12 | +3/16 -1/16 |
| 12 | 24 | +1/4 -1/8 |
| 24 | -- | +1/2 -1/4 |

TABLE IX. Tolerances on preformed (type II) hose length.

| Each end (measured from end to intersect of nearest centerline) | (inch) |
|---|-------------|
| | +3/16 - 1/8 |

3.2.7 Hose length.

3.2.7.1 Type I. Unless otherwise specified (see 6.2), type I bulk hose shall be furnished in lengths of 3, 25 or 40 feet, or multiples thereof.

3.2.7.2 Type IV. Specify the length of type IV hose required in feet (see 6.2). The hose length includes the length of the steel end fittings.

A-A-52426A

3.3 Physical requirements.

3.3.1 Burst pressure. Hose shall not burst at any pressure below that specified in table X when tested in accordance with ASTM D380.

TABLE X. Hose burst pressure.

| Type | Nominal ID (inch) | Min burst pressure (psi) |
|--------------|-------------------|--------------------------|
| I | 3/8 | 425 |
| | 1/2 | 425 |
| | 5/8 | 425 |
| | 3/4 | 425 |
| | 7/8 | 425 |
| | 1 | 375 |
| | 1 1/8 | 375 |
| I, II, & III | 1 1/4 | 350 |
| | 1 3/8 | 350 |
| | 1 1/2 | 350 |
| | 2 | 325 |
| | 2 1/4 | 300 |
| | 2 3/8 | 300 |
| | 2 1/2 | 250 |
| | 2 3/4 | 200 |
| | 3 | 200 |
| | 3 1/2 | 175 |
| 4 | 150 | |
| IV | 1/2 | 350 |
| | 5/8 | 275 |
| | 7/8 | 200 |
| | 1 1/8 | 175 |

3.3.2 Durometer hardness. Hose durometer shall be as specified in table I when tested in accordance with ASTM D2240.

3.3.3 Tensile strength and elongation. Hose tensile strength and elongation shall be as specified in table I when tested in accordance with ASTM D412.

3.3.4 Resistance to heat. Hose resistance to heat shall be as specified in table I when tested in accordance with ASTM D573. Hose shall be aged for 72 hours at 350°F.

3.3.5 Resistance to oil. Hose resistance to oil shall be as specified in table I when tested in accordance with ASTM D471. Hose shall be immersed in test liquid IRM 903 for 72 hours at 112 °F.

A-A-52426A

3.3.6 Resistance to coolant. Hose resistance to coolant shall be as specified in table I when tested in accordance with ASTM D471. Hose shall be immersed in solution of 60 percent inhibited ethylene glycol antifreeze conforming to type I of A-A-52624, and 40 percent water for 166 hours at 235 °F.

3.3.7 Adhesion. Hose construction adhesion shall be as specified in table XI when tested in accordance with ASTM D413.

TABLE XI. Hose adhesion.

| | Types I, II, and IV | | Type III | |
|-----------------------|---------------------|-------|------------|-------|
| | Inner tube | Cover | Inner tube | Cover |
| Adhesion, min, pounds | | | | |
| Tube to ply | 10 | 10 | N/A | N/A |
| Tube to cover | 10 | N/A | 10 | N/A |
| Ply to ply | N/A | 10 | N/A | N/A |
| Cover to ply | N/A | 10 | N/A | N/A |

3.3.8 Low temperature flexibility. Hose shall evidence no cracks or breaks when tested in accordance with ASTM D380 at a test temperature of -40 °F.

3.3.9 Ozone resistance. Hose shall evidence no cracking or degradation after ozone exposure in accordance with ASTM D1149.

3.3.10 Proof pressure. Hose shall exhibit no leakage during or after proof pressure test in accordance with ASTM D380. Proof pressures shall be one-half the minimum burst pressure values specified in table X.

3.3.11 Pulsating proof pressure. Hose shall not bulge, separate, or leak during or after pulsating proof pressure test in accordance with ASTM D380. The 40 psi internal pressure shall be applied in pulsating cycles of five seconds for 15 minutes total. The five second cycle shall be 2 seconds pressurized and 3 seconds unpressurized.

3.3.12 Resistance to vibration (type III). Hose shall not leak or evidence other damage during or after 50 hours of vibration at 30 ± 5 Hertz and 0.25 inch double amplitude. Water shall be circulated through the hose during vibration at 1/4 of its respective table X burst pressure. Hose up to and including one inch inside diameter shall be installed on the vibration fixture in a manner incorporating a 90 degree bend and a 45 degree circumferential twist. Larger inside diameter hose shall be mounted horizontally with a 45 degree circumferential twist. Each test specimen shall consist of a 24 inch long hose which has been conditioned for 24 hours at 80 ± 9 °F.

3.3.13 Resistance to compression set test. Hose shall meet the compression set requirements of table I after being subjected to compression set test in accordance with ASTM D395, after aging

A-A-52426A

for 70 hours at 302°F. Molded test slabs, representative of batch from which hose is made, may be used.

3.4 Installation. Type I, II, and IV hose shall be installed with clamps conforming to SAE J1508, type F, style 1, 2, or 4, or A-A-52506; type F.

3.5 Identification and marking. Types I, II and IV shall be marked on the outer surface. Type III shall be marked on one or both cuffs. All marking shall include the following information in contrasting color by stencil or printed type:

National stock number
Nominal size (ID)
A-A-52426(AT)
Type
Manufacturers identification code (CAGE)
Month and year of manufacture 1/

1/ Month and year of manufacture shall be recorded, but shall apply for reference purposes only.

3.6 Workmanship. Workmanship shall be such as to produce hose free of looseness of cover, exposed reinforcements (wire, fabric), cuts or bruises, blisters, breaks, pitting, wrinkles in cover, loose foreign matter, excess mandrel lubricants, or any other defects which adversely affect hose performance or appearance.

4.0 PRODUCT CONFORMANCE PROVISIONS.

4.1 Responsibility for inspection. The contractor is responsible for the performance of all inspections (examination and tests).

4.2 Contractor certification. The contractor shall certify and maintain substantiating evidence that the product offered meets the salient characteristics of this CID and that the product conforms to the producer's own drawings, specifications, standards, and quality assurance practices. Items with known defects shall not be submitted for Government acceptance. The Government reserves the right to require proof of such conformance prior to the first delivery and thereafter as may be otherwise provided for under the provisions of the contract.

5.0 PACKAGING. Preservation, packing, and marking shall be as specified in the contract or order (see 6.2).

6.0 NOTES.

6.1 Addresses for obtaining copies of referenced documents (see 6.2).

A-A-52426A

6.1.1 Government specifications and standards.

Documents are available from the Document Automation and Production Service, Building 4/D, 700 Robbins Avenue, Philadelphia, PA 19111-5094 or website: <https://assist.dla.mil/quicksearch/>.

A-A-52506 - Clamps, Hose

A-A-52624 - Antifreeze, Multi Engine Type

6.1.2 Non-Government publications.

ASTM International

Documents are available from American Society for Testing and Materials, 100 Barr Harbor Drive, West Conshohocken, PA 19428-2959 or <http://www.astm.org/>.

- ASTM B633 - Electrodeposited Coatings of Zinc on Iron and Steel
- ASTM B841 - Standard Specification for Electrodeposited Coatings for Zinc Nickel Alloy Deposits
- ASTM D380 - Rubber Hose
- ASTM D395 - Compression Set of Rubber
- ASTM D412 - Rubber, Determination of Tension Characteristics
- ASTM D413 - Rubber Property-Adhesion to Flexible Substrate
- ASTM D471 - Rubber Property-Effect of Liquids
- ASTM D573 - Rubber-Deterioration in an Air Oven
- ASTM D1149 - Rubber Deterioration-Surface Ozone Cracking in a Chamber (Flat Specimen)
- ASTM D2240 - Indentation Hardness of Rubber and Plastics by Means of a Durometer

SAE International

Documents are available from the Society of Automotive Engineers, Inc., 400 Commonwealth Drive, Warrendale, PA 15096-0001 or website: <http://www.sae.org/>.)

- SAE J516 - Hydraulic Hose Fittings
- SAE J1508 - Hose Clamps
- SAE J20/2 - Coolant Hose - Normal Service Type Convuluted, Wire Support Hose

A-A-52426A

6.2 Ordering data. Acquisition documents must specify the following:

- a. Title, number, and date of this CID.
- b. If required, the specific issue of individual documents referenced (see 6.1).
- c. Length of type I hose (see 3.2.7.1).
- d. Length of type IV hose (see 3.2.7.2).
- e. Selection of applicable level and packaging requirements (see 5.0).
- f. Part Identification Number (PIN) required (see 6.3)

6.3 Part or identification number (PIN). The PIN to be used for hose acquired to this CID is as follows (see 6.2):

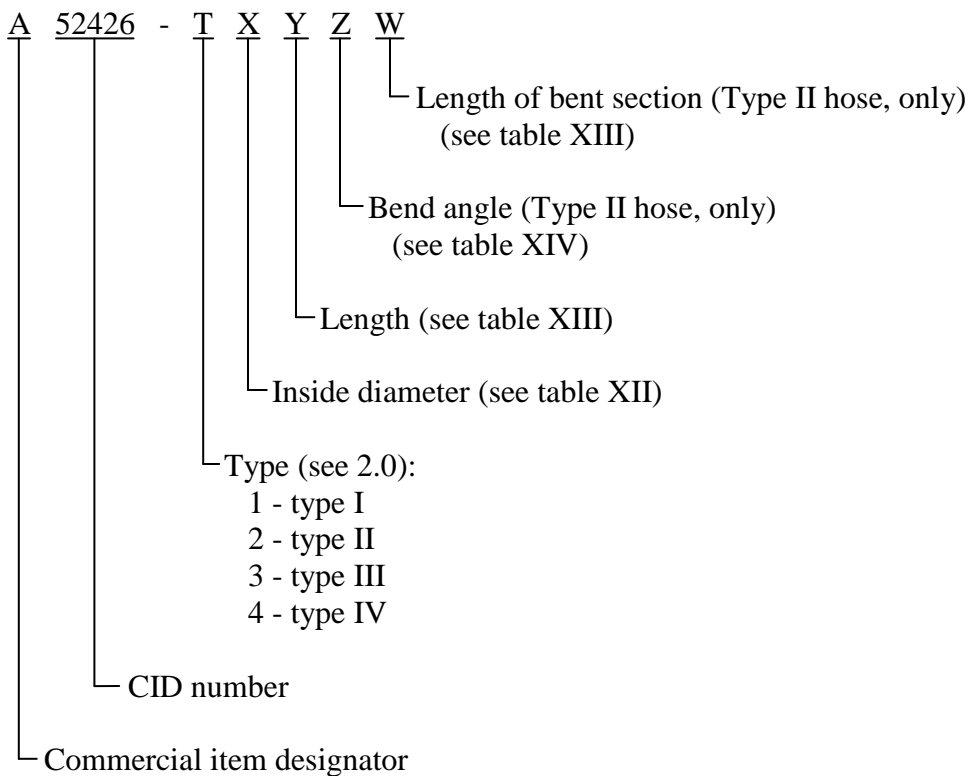

A-A-52426A

TABLE XII. Hose inside diameter.

| A 52426 Dash size 'X' | Nominal ID (inch) | Superseded Dash Size | | | |
|-----------------------------|----------------------|----------------------|-----------------------|------------------------|-----------------------|
| | | M62217/1 (type I) | M62217/2 (type II) | M62217/3 (type III) | M62217/4 (type IV) |
| A | 3/8 | 6 | | | |
| B | 1/2 | 8 | | | 10 |
| C | 5/8 | 10 | | | 12 |
| D | 3/4 | 12 | | | |
| E | 7/8 | 14 | | | 16 |
| F | 1 | 16 | | | |
| G | 1-1/8 | 18 | | | 20 |
| H | 1-1/4 | 20 | A | A | |
| J | 1-3/8 | 22 | | | |
| K | 1-1/2 | 24 | B | B | |
| L | 1-3/4 | 28 | C | C | |
| M | 2 | 32 | D | D | |
| N | 2-1/4 | 36 | E | E | |
| P | 2-3/8 | 38 | | | |
| R | 2-1/2 | 40 | F | F | |
| S | 2-3/4 | 44 | | | |
| T | 3 | 48 | G | G | |
| V | 3-1/2 | 56 | | | |
| W | 4 | 64 | H | H | |

TABLE XIII. Hose length.

| A 52426 Dash size 'Y' and 'W' | Length (inch) | Superseded Dash Size | |
|-------------------------------------|------------------|-----------------------|------------------------|
| | | M62217/2 (type II) | M62217/3 (type III) |
| A | 5 | A | R5 |
| B | 6 | B | R6 |
| C | 7 | C | R7 |
| D | 8 | D | R8 |
| E | 9 | E | R9 |
| F | 10 | F | R10 |
| G | 11 | G | R11 |
| H | 12 | H | R12 |
| J | 14 | J | R14 |
| K | 16 | K | R16 |
| L | 18 | L | R18 |
| M | 20 | M | R20 |
| N | 22 | N | R22 |

A-A-52426A

TABLE XIII. Hose length – Contunued.

| A 52426 Dash size (‘Y’ and ‘W’) | Length (inch) | Superseded Dash Size | |
|---------------------------------------|------------------|-----------------------|------------------------|
| | | M62217/2 (type II) | M62217/3 (type III) |
| P | 24 | P | R24 |
| R | 26 | R | R26 |
| S | 28 | S | R28 |

NOTE See 3.2.7 for length of type I and type IV bulk hose.

TABLE XIV. Hose bend angle.

| A 52426 Dash no. (‘Z’) | Bend Angle | Superseded M62217/2 (type II) Dash no. |
|------------------------------|---------------|--|
| A | 15° | A |
| B | 30° | B |
| C | 45° | C |
| D | 60° | D |
| E | 75° | E |
| F | 90° | F |

6.4 Supersession data. This CID supersedes MIL-H-62217A(AT), dated 16 January 1981, MIL-H-62217/1A(AT), dated 6 August 1984, MIL-H-62217/2(AT), dated 12 September 1974, and MIL-H-62217/4(AT), dated 12 September 1974.

6.5 Cross-reference. Hose conforming to this CID is substitutable/interchangeable with hose conforming to MIL-H-62217A(AT) as shown in table XV with tables XII, XIII and XIV dash numbers/sizes.

TABLE XV. Sample PIN cross reference.

| A 52426 PIN | Superseded PIN |
|-----------------------|-------------------|
| A 52426-1D <u>1</u> / | M62217/1-12 - 36 |
| A 52426-2LABG | M62217/2 C A B G |
| A 52426-3LA | M62217/3 C R5 |
| A 52426-4C <u>2</u> / | M62217/4 12 25 |

NOTE: 1/ See 3.2.7.1 and 6.2 to specify type I bulk hose length.

2/ See 3.2.7.2 and 6.2 to specify type IV hose length.

6.6 Regulatory requirements. The offeror/contractor is encouraged to use recovered materials to the maximum extent practicable, in accordance with paragraph 23.403 of the Federal Acquisition Regulation (FAR). The Federal Acquisition Regulation (FAR) may be obtained at the following website: <http://www.acquisition.gov/far/>.

A-A-52426A

6.7 Metric products. Products manufactured to metric dimensions will be considered on an equal basis with those manufactured using inch-pound units, provided they fall within specified tolerances using conversion tables contained in the latest revision of IEEE/ASTM-SI10, and all other requirements of this CID are met. If a product is manufactured to metric dimensions and those dimensions exceed the tolerances specified in the inch-pound units, a request should be made to the contracting officer to determine if the product is acceptable. The contracting officer has the option of accepting or rejecting the product.

Custodian:

Army - AT

Preparing activity:

Army - AT

Review activity:

DLA - CC

Army - CR4

(Project 4720 - 2011 - 001)

NOTE: The activities listed above were interested in this document as of the date of this document. Since organizations and responsibilities can change, you should verify the currency of the information above using the ASSIST Online database at <https://assist.dla.mil>.