

INCH-POUND

A-A-52414B

28 August 2012

SUPERSEDING

A-A-52414A

2 August 2005

## COMMERCIAL ITEM DESCRIPTION

## BEARING, ROLLER, THRUST

The General Services Administration has authorized the use of this commercial item description (CID) as a replacement for MIL-B-17380A and MS17103A which are canceled.

1. **SCOPE.** This CID covers thrust roller bearings consisting of two flat thrust plates, cylindrical rollers, and a retainer (see figure 1). They are used where the shaft axis is parallel to the load.

## 2. SALIENT CHARACTERISTICS

2.1 **Materials.** Thrust plates and rollers shall be made of vacuum degassed bearing quality steel and have a hardness of RC 58-60 for the thrust plates and RC 60-64 for the rollers. The retainer shall be made of cast bronze or brass and provided with a hardened steel band to resist the outward thrust of the rollers. The use of recovered materials made in compliance with regulatory requirements is acceptable providing that all requirements of this CID are met (see 3).

2.2 **Design and construction.** The general design and construction features of roller thrust bearings are shown in figure 1. The rollers shall be crowned and their lengths shall alternate from short to long in successive slots around the body of the retainer. The flat faces of each thrust plate shall be parallel within 1 mil. The roller diameters shall be uniform to within 0.25 mils. The difference in diameter between the rollers in any one bearing assembly shall not exceed 0.25 mils. The rollers shall remain in the retainer when the bearings are disassembled. Detailed and specific features and dimensions shall be specified in an engineering drawing (see 6.1).

Beneficial comments, recommendations, additions, deletions, clarifications, etc. and any data that may improve this document should be sent to [usarmy.detroit.rdecom.mbx.tardec-standardization@mail.mil](mailto:usarmy.detroit.rdecom.mbx.tardec-standardization@mail.mil) or U.S. Army RDECOM, Tank Automotive Research, Development and Engineering Center, ATTN: RDTA-EN/STND/TRANS MS #268, 6501 E. 11 Mile Road, Warren, MI 48397-5000. Since contact information can change, you may want to verify the currency of this address information using the ASSIST Online database at <https://assist.dla.mil>.

AMSC N/A

FSC 3110

DISTRIBUTION STATEMENT A. Approved for public release; distribution is unlimited.

A-A-52414B

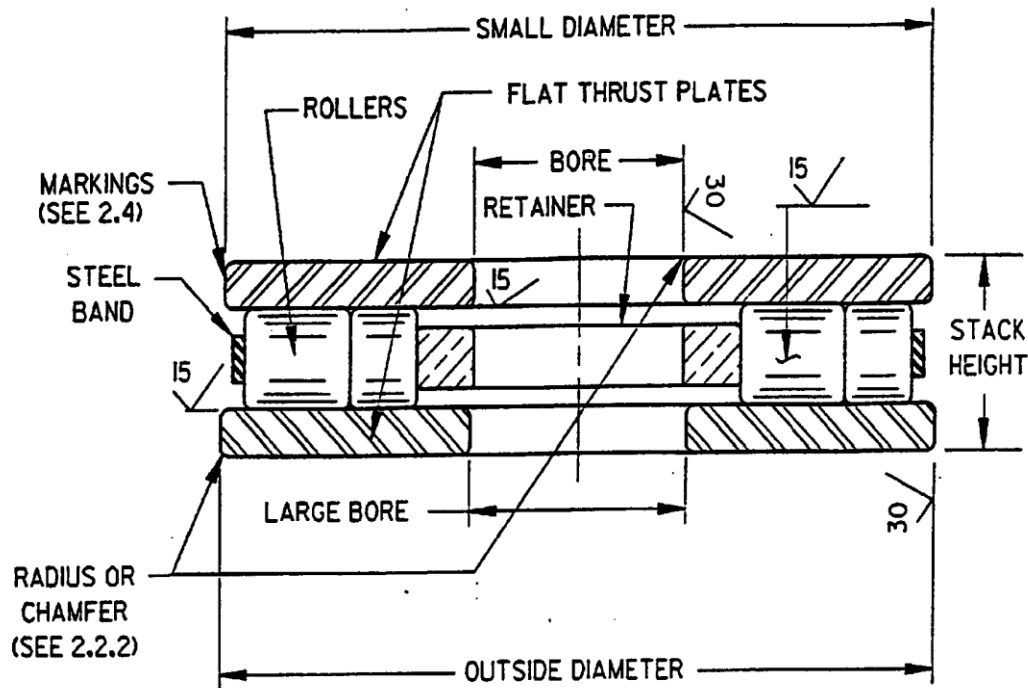
FIGURE 1. Bearing configuration.

2.2.1 Size. The size of the roller thrust bearings and tolerances shall be determined based on specific bearing application requirements and shall be given in the engineering drawing. Factors such as load, rpm, environmental conditions (e.g., temperature, humidity) are taken into consideration. The basic empirical formula used for the dynamic load capacity is explained in 6.2.

2.2.2 Radius or chamfer. Bearings must clear the maximum fillet radius of the mating shaft or housing. A radius or chamfer (see figure 1), of 0.031 inch minimum, shall be used on the bore and outer diameter.

2.3 Surfaces. The surfaces labeled 15 and 30 in figure 1 shall have a maximum surface roughness of 15 and 30 micrometers, respectively. Ground surfaces shall be free from tool marks, chatter waves, pits, rust or other injurious defects. All other surfaces shall have a smooth machine finish, free from scale. The bearings shall be supplied without lubrication, but with a coating of rust preventive film.

2.4 Identification and markings. The product shall be identified and marked in accordance with the engineering drawing to include, as a minimum, the military part number and the manufacturer's CAGE code and part number (see 6.1).

## A-A-52414B

2.5 Workmanship. The product shall be free from dirt, oil, or other foreign material, except as required for preservation (see 5.0). Workmanship shall be of a quality which assures a product free from burrs, slivers, surface scratches, or sharp corners or edges. There shall be no paint runs, smears, corrosion or other defects which could adversely affect appearance, operation, or installation.

3. REGULATORY REQUIREMENTS. The offeror/contractor is encouraged to use recovered materials to the maximum extent practicable, in accordance with paragraph 23.403 of the Federal Acquisition Regulation (FAR).

### 4. PRODUCT CONFORMANCE PROVISIONS.

4.1 Contractor certification. The contractor shall certify and maintain substantiating evidence that the product offered meets the salient characteristics of this CID and that the product conforms to the producer's own drawings, specifications, workmanship standards, and quality assurance practices. Items with known defects shall not be submitted for Government acceptance. The Government reserves the right to require proof of such conformance prior to the first delivery and thereafter as may be otherwise provided for under the provisions of the contract or order.

5. PACKAGING. Preservation, packing, and marking shall be as specified in the contract or order (see 6.1).

### 6. NOTES

(This section contains information of a general or explanatory nature that may be helpful but is not mandatory.)

6.1 Ordering data. Acquisition documents should specify the following:

- a. Title, number, and date of this CID.
- b. If required, the specific issue of individual documents referenced.
- c. Number and date of the engineering drawing (see 2.2).
- d. Military part number and quantity required (see 2.4).
- e. Selection of applicable level and packaging requirements (see 5.0).

6.2 Basic design formula. The following formula may be used for design and selection. The determination of the operating conditions factor ( $f_{oc}$ ) is beyond the scope of this document but can be found according to Anti-Friction Bearing Manufacturers Association (AFBMA) standards. This factor makes an adjustment to the load capacity by considering parameters such as: Reliability, materials, lubrication, dimensions, and external environment.

## A-A-52414B

$$C = P (0.00006Ln)^{0.3}/f_{oc}$$

where, C = dynamic load capacity rating in pounds  
 P = equivalent dynamic bearing load in pounds  
 L = required or resultant rating life in hours  
 n = operating speed in revolutions per minute  
 $f_{oc}$  = overall operating conditions factor (see 6.2)

6.3 Cross-reference. Bearings conforming to this CID are substitutable or interchangeable with bearings conforming to MIL-B-17380A dated 7 April 1954 and MS17103A dated 18 October 1966.

6.4 Metric product.

- a. Products manufactured to metric dimensions will be considered on an equal basis with those manufactured using inch-pound units, provided they fall within specified tolerances using conversion tables contained in the latest revision of ASTM SI10, and all other requirements of this CID are met.
- b. If a product is manufactured to metric dimensions and those dimensions exceed the tolerances specified in the inch-pound units, a request should be made to the contracting officer to determine if the product is acceptable.
- c. The contracting officer has the option of accepting or rejecting the product.

## MILITARY INTERESTS:

## Custodians:

Army - AT  
 Navy - OS  
 Air Force - 99

## Review activities:

Army - AR  
 Navy - MC, SH  
 Air Force - 84  
 DLA - GS, IS

## CIVIL AGENCY COORDINATING ACTIVITY:

GSA - FAS

## PREPARING ACTIVITY:

Army - AT

(Project 3110-2012-001)

NOTE: The activities listed above were interested in this document as of the date of this document. Since organizations and responsibilities can change, you should verify the currency of the information above using the ASSIST Online database at <https://assist.dla.mil>.