

INCH-POUND

A-A-52409B
03 MARCH 2016
SUPERSEDING
A-A-52409A
21 APRIL 2010

COMMERCIAL ITEM DESCRIPTION

LAMPS, INCANDESCENT, SEALED BEAM

The General Services Administration has authorized the use of this commercial item description for all federal agencies.

1. **SCOPE.** This commercial item description (CID) covers requirements for incandescent sealed beam lamps which provide illumination of the road and its environment.

2. SALIENT CHARACTERISTICS

2.1 **Incandescent sealed beam lamps.** Unless otherwise specified herein, the salient characteristics and markings for incandescent sealed beam lamps shall conform to SAE J1383.

2.2 **Characteristics.** The physical and electrical characteristics of the incandescent sealed beam lamps are as specified in figures 1 through 4.

2.3 **Workmanship.** Workmanship shall be in accordance with the manufacture of high quality incandescent sealed beam lamps. This shall be evidenced by the absence of defects which are detrimental to the appearance, serviceability, or durability of the headlamps such as: surface deterioration, fractures, color bleeding, deterioration of bonding material, exterior or internal corrosion.

2.4 **Materials.** The use of recovered material made in compliance with regulatory requirements is acceptable providing that all requirements of this CID are met (see [3.1](#)).

Beneficial comments, recommendations, additions, deletions, clarifications, etc. and any data that may improve this document should be sent to: STDZNMGT@dla.mil or DLA Aviation VEB, 8000 Jefferson Davis Highway, Richmond, VA 23297-5616. Since contact information can change, you may want to verify the currency of this address information using the ASSIST database at <https://assist.dla.mil/>

A-A-52409B

3. REGULATORY REQUIREMENTS

3.1 Recovered materials. The offeror/contractor is encouraged to use recovered materials to the maximum extent practicable, in accordance with paragraph 23.403 of the Federal Acquisition Regulation (FAR).

4. PRODUCT CONFORMANCE PROVISIONS

4.1 Product conformance. The products provided shall meet the salient characteristics of this CID, conform to the producer's own drawings, specifications, standards, and quality assurance practices, and be the same product offered for sale in the commercial marketplace. The government reserves the right to require proof of such conformance.

4.2 Market acceptability. The products offered must have been previously sold either to the government or on the commercial market.

5. PACKAGING

5.1 Preservation, packing, and marking. Preservation, packing, and marking shall be as specified in the acquisition order (see [6.3\(b\)](#)).

6. NOTES

6.1 Part or identification number (PIN). The following PIN procedure is for government purposes and does not constitute a requirement for the contractor.

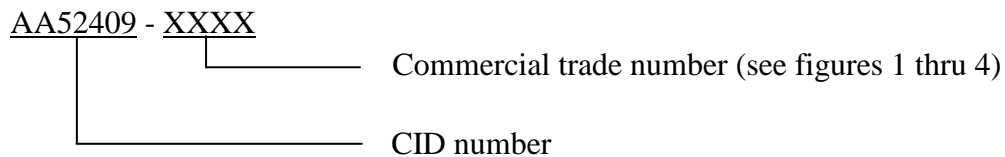

Example of reference part number: AA52409-4435 indicates an incandescent sealed beam spot lamp rated 12 volts, 30 watts, filament type CC-6, with an average lab life of 100 hours.

6.2 Sources of documents.

6.2.1 FAR. Electronic copies of FAR documents may be obtained from <https://www.acquisition.gov/far/>.

6.2.2 Federal CIDs. Electronic copies may be obtained from <https://assist.dla.mil/>.

6.2.3 ASTM standards. Electronic copies may be obtained from <http://www.astm.org/>.

6.2.4 IEEE standards. Electronic copies may be obtained from <http://www.ieee.org/>.

A-A-52409B

6.2.5 SAE standards. Electronic copies may be obtained from <http://www.sae.org/>.

6.3 Ordering data. The acquisition order should specify the following information:

- a. CID document number, revision, and CID PIN.
- b. Preservation, packing, and marking (see [5.1](#)).

6.4 Metric products. Incandescent sealed beam lamps that are manufactured to metric dimensions will be considered on the following basis:

a. Products manufactured to metric dimensions will be considered on an equal basis with those manufactured using inch-pound units provided they fall within specified tolerances of IEEE/ASTM SI 10, "American National Standard for Use of the International System of Units (SI): The Modern Metric System", and all other requirements of this CID are met.

b. If a product is manufactured to metric dimensions and those dimensions exceed the tolerances specified in the inch/pound units, a request should be made to the contracting officer to determine if the product is acceptable.

c. The contracting officer has the option of accepting or rejecting the product.

6.5 Cross-reference data. Incandescent sealed beam lamps conforming to this CID are interchangeable/substitutable with incandescent sealed beam lamps conforming to MS18005, MS18006, MS18007, MS18008B, and MS18010A.

6.6 Subject term (key word) listing.

Bulb
Floodlight
Headlamp
Headlight
Searchlight
Spotlight

A-A-52409B

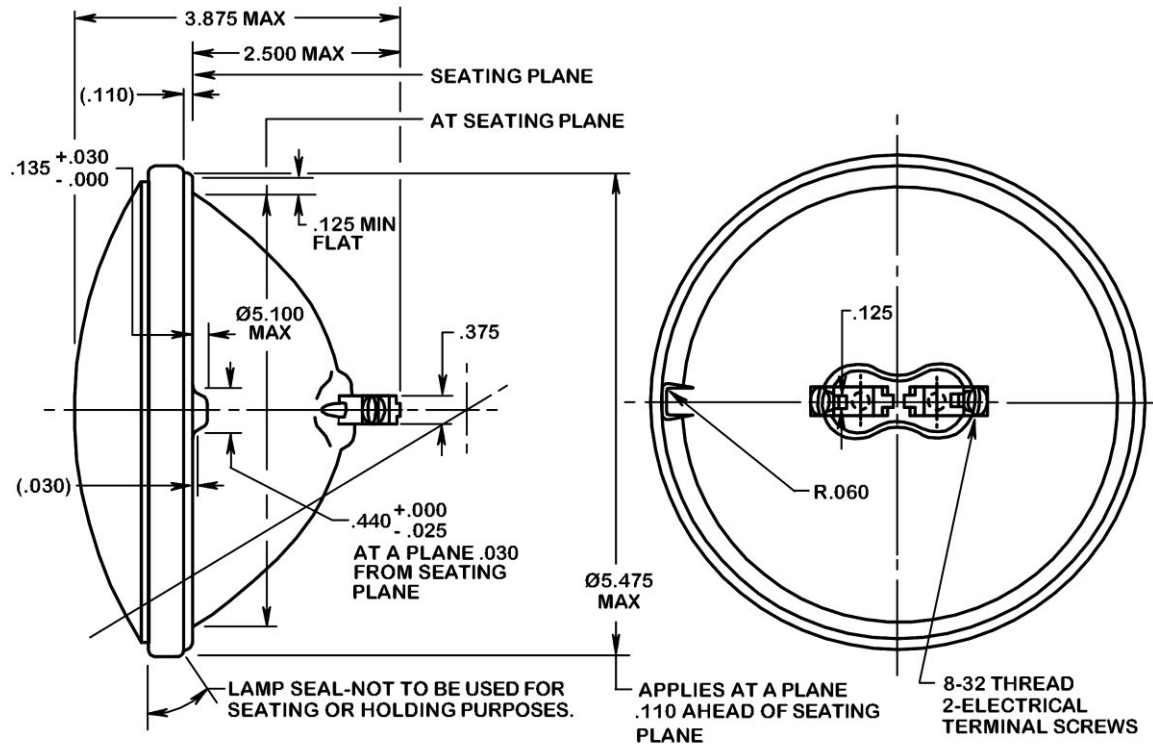

PIN no.	Former MS part no.	Former part no.	Rated		Design		Filament type	Rated avg. lab life
			Volts	Watts	Volts	Amps		
AA52409-4435	MS18005-4435	ORD 446660	12.0	30.0	12.8	2.34	CC-6	100 hrs.
AA52409-4525	MS18005-4525	-	3.7	2.2	3.7	0.60	C-6	200 hrs.
AA52409-4530	MS18005-4530	ORD 193141	24.0	135.0	26.0	5.20	4CC-8	50 hrs.
AA52409-4533	MS18005-4533	ORD 193138	6.0	40.0	6.5	6.20	5C-8	50 hrs.
AA52409-4535	MS18005-4535	ORD 444279	6.0	30.0	6.4	4.69	C-6	100 hrs.
AA52409-4572	MS18006-4572	ORD 573141	24.0	150.0	28.0	5.36	CC-6	300 hrs.

Description: Clear glass lens, PAR46, filament shield for all except AA52409-4525 and AA52409-4572
AA52409-4525 - Clear glass lens, PAR46
AA52409-4572 - Clear glass prismatic lens, PAR46

NOTES:

1. Dimensions are in inches.
2. Untoleranced dimensions are nominal and to be used for reference only.

FIGURE 1. Incandescent sealed beam spot/flood lamps, 2-screw terminal type.

A-A-52409B

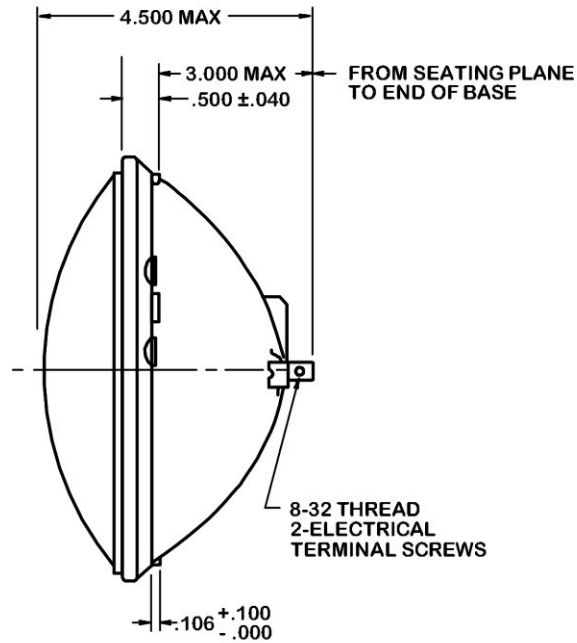

PIN no.	Former MS part no.	Rated		Design		Filament type	Rated avg. lab life
		Volts	Watts	Volts	Amps		
AA52409-4541	MS18007-4541	28	450	28	16.1	C-13	25 hrs.
Description: Clear glass lens, PAR56, filament shield							

NOTES:

1. Dimensions are in inches.
2. Untoleranced dimensions are nominal and to be used for reference only.

FIGURE 2. Incandescent sealed beam spot lamp, 2-screw terminal type.

A-A-52409B

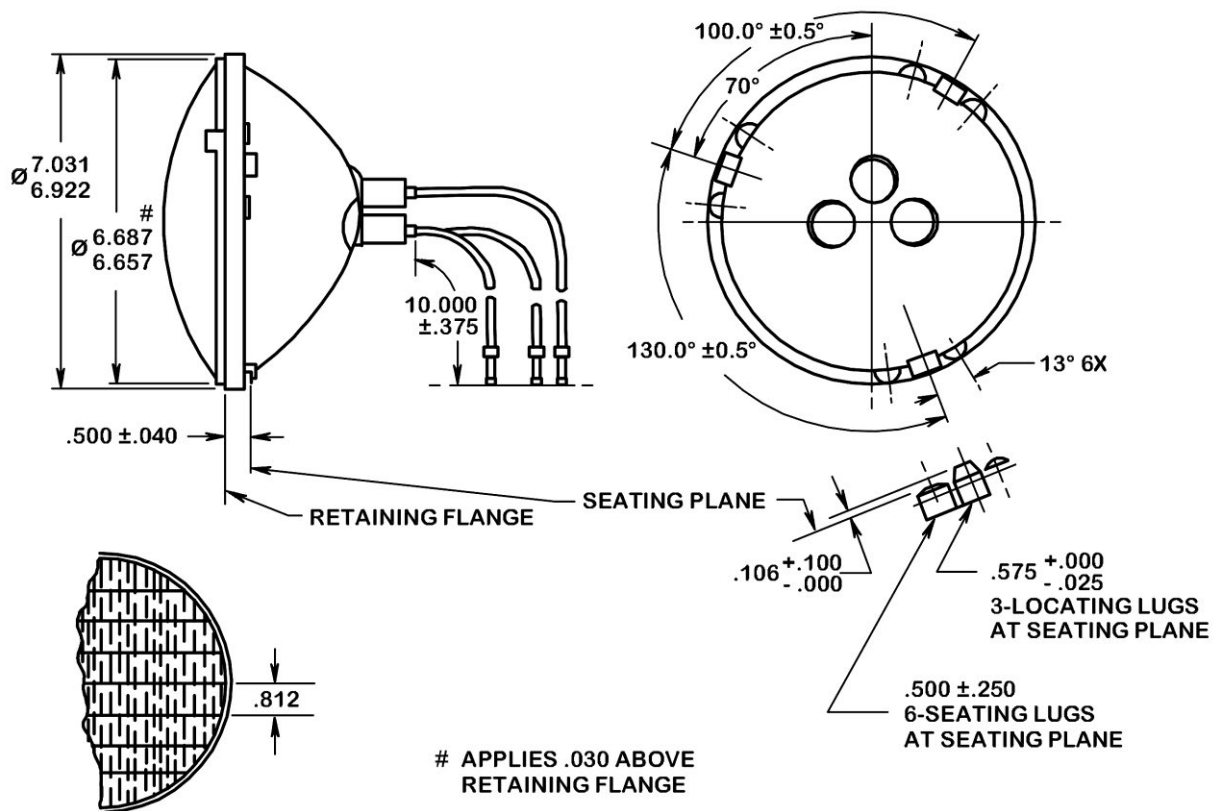

PIN no.	Former MS part no.	Army former part no.	Rated		Design		Filament type	Rated avg. lab life
			Volts	Watts	Volts	Amps		
AA52409-4863	MS18008-4863	7998618	24	80/60	28/28	2.86/2.14	CC6/CC6	400 hrs.
Description: Clear glass prismatic lens, PAR56, filament shield								

NOTES:

1. Dimensions are in inches.
2. Tolerances are $\pm .010$ unless otherwise specified.
3. Boot material shall be made of rubber.
4. The 3 cables shall be made of 14 gauge wire.
5. Contact pins to be used shall be in accordance with A-A-52536, "Contact, Electrical No. 12, 14, and 16 A.W.G.".

FIGURE 3. Incandescent sealed beam headlamp, 3-cable type.

A-A-52409B

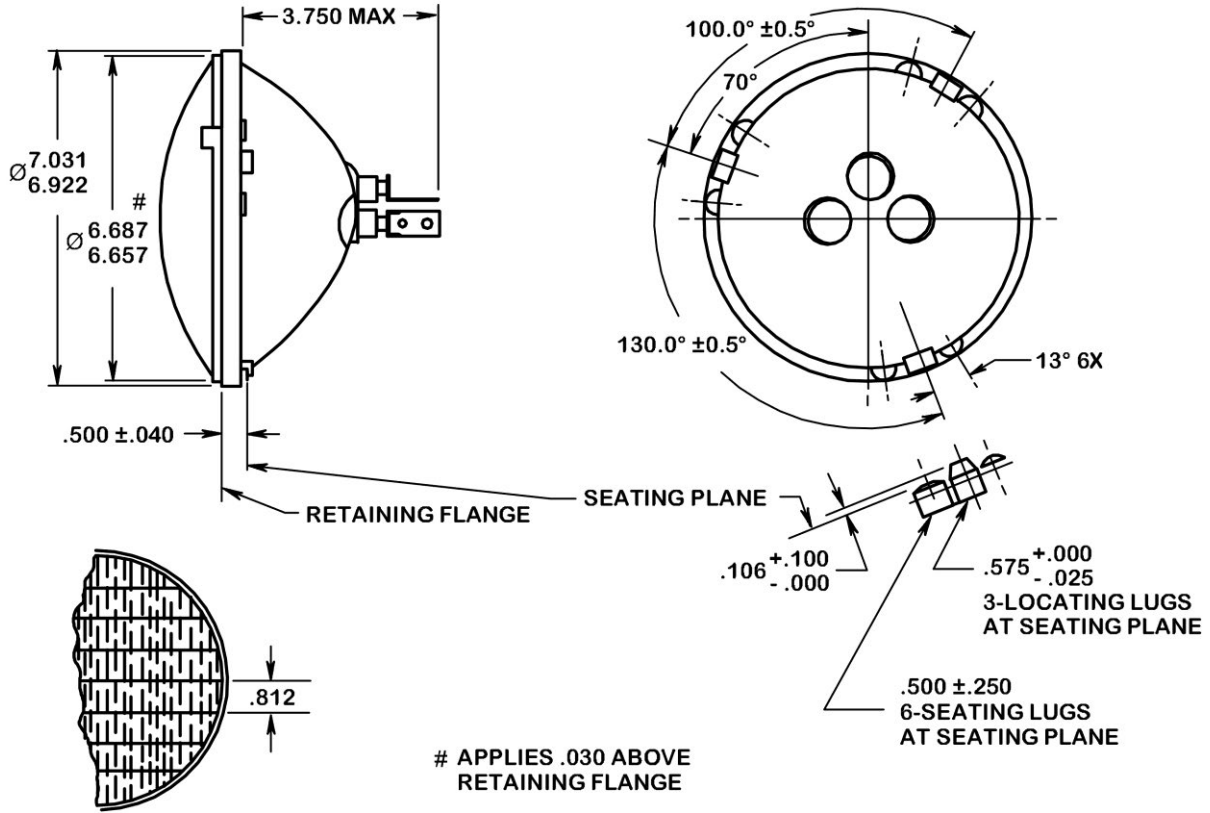

PIN no.	Former MS part no.	Rated		Design		Filament type	Rated avg. lab life
		Volts	Watts	Volts	Amps		
AA52409-4801	MS18010-4801	24	80/60	28/28	2.86/2.14	CC6/CC6	400 hrs.
Description: Clear glass prismatic lens, PAR56, filament shield							

NOTES:

1. Dimensions are in inches.
2. Tolerances are $\pm .010$ unless otherwise specified.

FIGURE 4. Incandescent sealed beam headlamp, 3-contact lug type.

A-A-52409B

MILITARY INTERESTS:

Custodians:

Army - AT
Navy - YD
Air Force - 99
DLA - GS

Review Activities:

Navy - SH
Air Force - 11, 71

**CIVIL AGENCY
COORDINATING ACTIVITY:**

GSA - FAS

Preparing Activity:

DLA - GS2

(Project 6240-2016-001)

NOTE: The activities listed above were interested in this document as of the date of this document. Since organizations and responsibilities can change, you should verify the currency of the information above using the ASSIST database at <https://assist.dla.mil/>.