

INCH-POUND

A-A-50696A

23 May 2014

Superseding

A-A-50696

11 July 1991

COMMERCIAL ITEM DESCRIPTION

REELS, STATIC DISCHARGE , GROUNDING, 50 AND 75 FOOT CABLE LENGTHS

The General Services Administration has authorized the use of this commercial item description for all federal agencies as a replacement for Military Specification Mil-R-83232 which is cancelled.

1. SCOPE. This Commercial Item Description describes industrial type static discharge reels with either 50 or 75 foot cable lengths (fully extracted) used to dispel static charges from ground support equipment. This Commercial Item Description (CID) Test Set Synchro provides a crystal controlled phase angle calibration standard. It produces two digitally synthesized, low distortion sine waves. Relative phase angles between two sine wave outputs may be varied by at least 0.002° over the range from $\pm 999.999^\circ$. This instrument will provide and measure phase angle signals for development, repair and maintenance of general electronics, navigational aids, satellite and other communications equipment.

2. CLASSIFICATION. The static discharge reels are classified as follows:

1	Type I	- Large (75 foot cable)
2	Type II	- Small (50 foot cable)

3.0 SALIENT CHARACTERISTICS.

3.1 Materials. The use of toxic or hazardous materials , as defined by the US Environmental Protection Agency, shall be the minimum consistent with performance requirements as stated herein.

Beneficial comments, recommendations, additions, deletions, clarifications, etc. and any data that may improve this document should be sent to: WR-ALC - AFLCMC/WNZ, 235 Byron Street Suite 19A, Robins AFB, GA 31098-1670. Since contact information can change, you may want to verify the currency of this address information using the ASSIST Online database at <https://assist.dla.mil/> .

AMSC N/A

FSC 4930

Distribution Statement A. Approved for public release; distribution is unlimited.

A-A-50696A

3.2 Metals. Those metals used shall possess low resistivity. Metals other than those specified shall be corrosion resistant or treated to resist corrosion throughout the life of the unit due to contact with fuels, salt spray, or the following atmospheric conditions:

- a. Storage temperatures of -80 degrees F to +160 degrees F
- b. Operational Temperatures between -65 degrees F and +125degrees F
- c. A relative humidity of 95 plus or minus 5 percent
- d. Airborne dust and sand particles encountered in desert operation.

3.3 Fungus-Proof materials. Materials which are not nutrients for fungi shall be used to the greatest practical extent. Where materials that are nutrients for fungi must be used, such materials shall be treated with a fungicidal agent commercially acceptable and compatible with those materials on which it is to be applied.

3.4 Dissimilar metals. Unless protected against electrolytic corrosion, dissimilar metals shall not be used in intimate contact with each other.

3.5 Construction. The reel trough shall be of such size to contain the entire cable lengths as specified herein when in the fully retracted position. When bolted to an appropriate fixture, the reel and base shall be so constructed as to be capable of withstanding a static load of 150-pounds applied at the cable free end grounding device or cable free end when grounding device is not installed.

3.6 Dimensions. The envelope dimensions of the reel in an upright position shall not exceed 12 inches in height, 11 inches in depth, and 5 inches in width. For mounting, two ½ inch diameter bolt holes shall be symmetrically located in the base 7 -7/8inches apart on center (see figure 1).

3.7 Mounting position. The unit shall be capable of operating when mounted in any position about a 360 degree axis.

3.8 Cable outlet guide. A cable outlet guide shall be provided that will allow the cable to return to the reel from any position within a 90 degree arc to the plane of rotation of the reel without kinking or tangling.

3.9 Automatic rewind. The reel shall be spring loaded with a spring manufactured from a corrosion resistant steel or one of steel that has been treated to prevent corrosion which will automatically retract the entire length of the cable extension when extended in any direction within 90 degrees from the axis of the cable outlet guide.

3.10 Cable latching mechanism. The reel shall be equipped with a latching mechanism to release and restore cable tension. After latching has occurred the cable shall remain in an extended position. Further extension of cable shall cause the latching mechanism to release and permit the cable to retract.

A-A-50696A

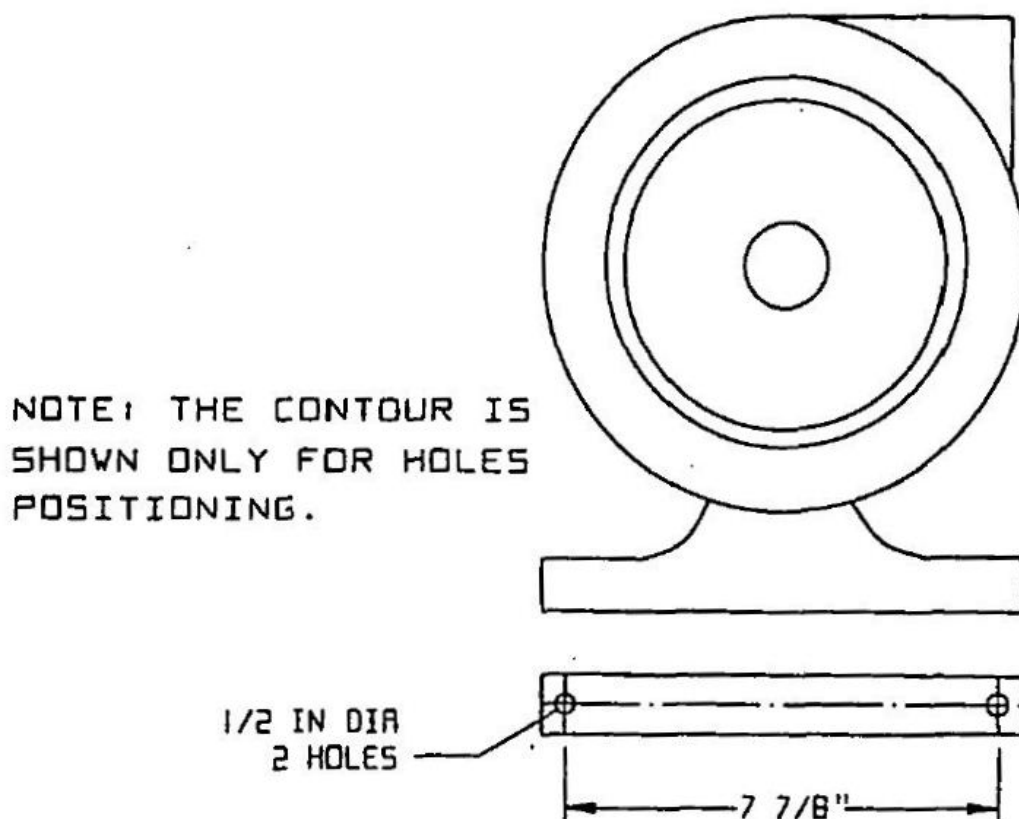
Figure 1. Mounting bolt hole locations.

3.11 Cable. The Type I reel shall contain a minimum of 75 feet of cable. The Type II reel shall contain a minimum of 50 feet of cable. The cable for the Type I and Type II reels shall be made of 7x7 strand commercial corrosion resistant steel with a nominal outside diameter of 3/32 inch. The cable shall have a 920 pound minimum breaking strength and no more than 6.67 ohms electrical resistance per 75 feet. This cable is not for flight control use. The cable shall be sheathed with a yellow Dupont Hytrel jacket having a 5/32 inch nominal diameter.

3.12 Cable stop. A cable stop will be furnished with each unit which is capable of preventing the cable from being inadvertently withdrawn into the reel housing.

3.13 Cable end ground devices. A welder style grip clamp (per MIL-C-83413/7) and a grounding plug (Per MIL-C-83413/4) shall be furnished with each reel assembly. The cable end grounding devices shall not be attached to the cable.

A-A-50696A

3.14 Color. The reel shall be color no. 24052 in accordance with FED-STD-595. Cleaning, painting, plating, anodic films, and chemical treatments shall be in accordance with MIL-HDBK-808.

3.15 Electrical resistance. The electrical resistance between the cable free end grounding device or end of cable if no grounding device is furnished (in either extended or retracted condition) and the contact surfaces on the mounting base or the reel frame shall not exceed 10 ohms. Metal components shall be electrically bonded together to prevent sparking during operation.

3.16 Repairability. The unit shall contain provisions for cable replacement under field conditions. Replacement of the cable and end attachments shall be accomplished using common hand tools.

3.17 Lubrication. The drum shaft bearings shall be permanently lubricated and sealed for the life of the unit. The use of grease fittings shall be limited only to the latching mechanism. Where lubricants are required, the reel shall so be designed that excess grease or oil cannot contaminate electrical contacts causing disruptions in continuity of the unit.

3.18 Reliability requirements. The unit provided by the contractor shall be capable of a minimum of 5000 cycles (full extensions and retractions) before failure.

3.19 Cable stop. A caution label with Black lettering on a Yellow background shall be packaged with the reel and will read as follows:

“Grounding clamps/plugs shall not be allowed to drag across the ramp.
Clamps/plugs shall be carried to reels on equipment.”

4.0 PRODUCT CONFORMANCE PROVISIONS

4.1 Responsibility for inspection. Unless otherwise specified in the contract, the contractor is responsible for the performance of all inspection requirements as specified herein. Except as otherwise specified in the contract, the contractor may use his own or any other facilities suitable for the performance of the inspection requirements specified herein, unless disapproved by the Government.

4.2 Classification of inspection. The inspection requirements specified herein are classified as first article inspection and quality conformance inspection.

4.3 First Article inspection. First article inspection shall be performed on one static discharge reel when a first article test is specified in the contract or order. This Inspection shall determine whether the contractor’s design meets all the salient characteristics specified herein and shall include examination and functional testing as specified herein.

4.4 Quality conformance inspection. Quality conformance inspection shall be performed on the sample static discharge reels selected in accordance with the inspection lot and sampling requirements. This inspection shall include examination and functional tests as specified herein.

A-A-50696A

4.5 Inspection lot. All units of the same class and style offered to the Government at one time shall be considered a lot for purpose of inspection. No inspection lot shall exceed 500 units. The sample unit shall be one complete reel and the sample size shall be determined by the Government Quality Assurance Representative, except that the sample size chosen for reliability testing shall not exceed one reel from each inspection lot.

4.6 Examination. Each sample selected in accordance with the inspection lot and sampling requirements, as well as the first article, shall be examined for compliance with salient characteristic requirements specified herein. This element of inspection shall encompass all visual and dimensional measurements.

4.7 Functional Tests.

4.7.1 Electrical resistance. The sample reels shall be tested for compliance with the electrical resistance requirements specified herein.

4.7.2 Reliability. The sample reels shall be tested for compliance with the reliability requirements specified herein. Reels used for reliability testing shall not be included in any Government shipment or order, but shall be retained for two years beyond the completion of the contract along with all records of inspection and testing.

4.8 Certification.

4.8.1 Contractor certification. The contractor shall certify and maintain substantiating evidence that the product offered meets the salient characteristics of this Commercial Item Description, and that the product conforms to the producer's own drawings, specifications, standards, and quality assurance practices. The government reserves the right to require proof of such conformance prior to first delivery and thereafter as may be otherwise provided for under the provisions of the contract.

4.9 Warranty.

4.9.1 Manufacturer/Contractor/Vendor warranty. The manufacturers' and suppliers' standard warranties shall be furnished at no additional cost to the Government.

4.10 Metric.

4.10.1 Metric products. Reels manufactured to metric dimensions will be considered on an equal basis with those manufactured using inch-pound units, provided they fall within specified tolerances using conversion tables contained in the latest revision of FED-STD-376, and all other requirements of this Commercial Item Description are met.

If a product is manufactured to metric dimensions; and those dimensions exceed the tolerances specified in the inch-pound units, a request should be made to the contracting officer to determine if the product is acceptable.

The contracting officer has the option of accepting or rejecting the product.

A-A-50696A

4.11 Recycled recovered materials. Recycled, recovered, or environmentally preferable materials should be used to the maximum extent possible provided that the material meets or exceeds the operational and maintenance requirements, and promotes economically advantageous life cycle costs. The offeror/contractor is encouraged to use recovered materials to the maximum extent practicable, in accordance with 23.403 of the Federal Acquisition Regulation (FAR). However, used, rebuilt, or refurbished items shall not be provided.

5.0 PACKAGING.

5.1 Preservation, packing and marking shall be as specified in the contract or order.

6.0 NOTES.

6.1 Acquisition requirements. Acquisition documents must specify the following:

- a. Title, number and date of the CID.
- b. Part Identifying number as designated by (PIN).
- c. First Article Inspection, when required.
- d. Whether a commercial off-the-shelf operating manual is to be furnished.
- e. Whether a commercial parts list is to be furnished.
- f. Whether applicable manufacturers drawings are to be furnished.
- g. Preservation, Packaging and markings to be as specified by the contract.

6.2 Part Identifying Number (PIN). The following PIN is developed for Government purposes and use with this CID. It does not constitute a requirement for the contractor:

SAMPLE: AA-50696-1

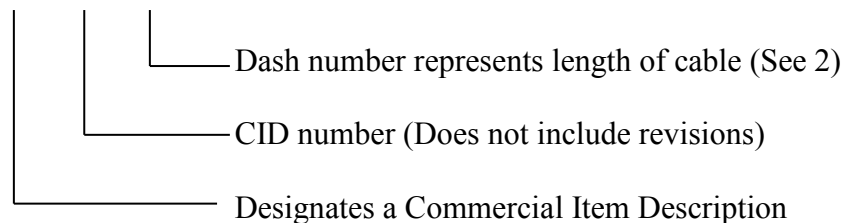
6.2 Source of documents.

6.2.1 Department of Defense and Federal documents may be obtained at <https://assist.dla.mil> or from the Document Automation and Production Service, Bldg 4D (DPM-DODSSP), 700 Robbins Avenue, Philadelphia PA 19111-5094.

6.2.2 FAR may be obtained from the Superintendent of Documents, P.O. Box 371954, Pittsburgh, PA 15250-7954. Electronic copies of the FAR may be obtained from www.acquisition.gov/far/.

A-A-50696A

6.3 Key Words.

Aircraft
Helicopter
Load Cells

Custodian:
Air Force - 84

Preparing activity:
Air Force - 84

Reviewer:
Air Force – 68, 99
DLA - CC

Agent:
Air Force – 99

Project 4930-2014-001

NOTE: The activities listed above were interested in this document as of the date of this document. Since organizations and responsibilities can change, you should verify the currency of the information above using the ASSIST Online database at <https://assist.dla.mil/> .