

[INCH-POUND]
A-A-3113
January 6, 1997
SUPERSEDING
AA-C-295
August 5, 1955

COMMERCIAL ITEM DESCRIPTION

CHAIRS, ROTARY, STEEL, TUBULAR, SPECIAL PURPOSE

The General Services Administration has authorized the use of this commercial item description, for all federal agencies.

Scope. This commercial item description covers tubular steel, rotary, armless chairs that are intended for groups of typists, telephone, or machine operators, draftsmen, and for similar personnel or areas where some degree of posture is required, but where it is not necessary to match other items of standard equipment. The class 1, size 1 chair is a fully adjustable posture chair.

Classification.

Class and size. The chairs shall be of the following classes and sizes.

Class 1 - Non-tilting seat, tilting adjustable back.

Size 1 - Standard base.

Class 2 - Non-tilting, seat, non-tilting adjustable backs.

Size 1 - Standard base.

Size 2 - Intermediate base.

Size 3 - High base.

Color of finish. The color of the chairs shall be gray, Color No. 26134 of Federal Standard Number 595. In addition, the manufacturers may offer their commercial colors.

Material. Materials shall be the best commercial grade provided by the manufacturer. Materials shall be suitable in every respect for the purpose intended. All materials shall be new and unused and free from defects that may affect serviceability or appearance of the finished product.

Design. The figures 1 through 4 illustrate the general appearance and typical construction of the chairs required. Adjustments for seat height and for both vertical and horizontal positioning of the back shall be provided. Low seat height position for size 1 chairs and range of vertical and horizontal back adjustments for all sizes of chairs shall be the manufacturer's standard

Beneficial comments, recommendations, additions, deletions, clarifications, etc. and any other data that may improve this document should be set to: General Services Administration, Federal Supply Service, National Furniture Center (3FNE-CO), Washington, DC 20406.

A-A-3113

commercial practice.

Workmanship. The details of construction including designs, joining, assembly, filling shall be in accordance with the manufacturer's best quality and commercial practice. Any of the above details which are not specified or shown in the figures shall be in accordance with first class, commercial, metal chair practice. Finished chairs shall be neat and free from any defects that affect the appearance or which might affect the serviceability of the chairs or the safety of the user.

Test Requirements. The chairs shall be tested as follows.

The chairs shall be tested in accordance with applicable requirement of ANSI/BIFMA X5.1-1993.

California Technical Bulletin 117 tests shall be performed on all chairs or on a representative chair provided that the components are identical to the tested chair

Unless otherwise specified in the contract or purchase order, the manufacturer/contractor is responsible for the performance of all inspection requirements specified herein. Sampling for inspection shall be performed in accordance with ANSI/ASQC Z1.4, unless the contracting officer or his/her representative approves an equal or better plan. A lot shall consist of chairs of one size and color. A sample shall be one each. Inspection levels and AQLs shall be as follows:

For fit, finish and all other workmanship - Level II, AQL 4.0 defects per hundred

Any failure to meet the Federal Standard color number 26134 in accordance with Federal Standard 595, identification label or performance requirements shall cause rejection of the lot.

Pretreatment and finishing. Chairs shall be coated with enamel, powder base or the manufacturer's best commercial coating.

The finish shall level out to produce smooth uniform surfaces without runs, wrinkles, grit, or areas of thin film.

Marking. The marking shall be in accordance with the manufacturers standard commercial practice. In addition, a label shall be affixed to the underside of the chairs and include the manufacturers name or trademark, contract number, National Stock Number (if specified), and month and year manufactured.

Preparation for delivery. Preservation and packing shall be in accordance with the manufacturer's best commercial practice. Swivel-rotary chairs shall be packed one per shipping container, with casters removed and packaged in the same container.

Marking. Marking of the shipping containers shall be as specified in the purchase order or if not specified, in accordance with the manufacturers standard markings.

Regulatory Requirement. The offeror/contractor is encouraged to use recovered materials in accordance with Public Law 94-580 to the maximum extent practicable.

Notes.

Ordering Options. Purchasers should specify the following:

- a. Color of finish
- b. Color of upholstery
- c. Class and size
- d. Packing instructions
- e. Shipping instructions

ANSI/BIFMA Standard.

The ANSI/BIFMA Standard is obtainable from American National Standards Institute, Inc., 1430 Broadway, New York, NY 10018.

ANSI/ASQC Z1.4 Standard. The ANSI/ASQC Standard is obtainable from The American Society for Quality Control, 611 East Wisconsin Avenue, Milwaukee, Wisconsin 53202.

Federal Standard Number 595. Color chip No.26134, gray, of Federal Standard Number 595 is obtainable from Business Service Center, General Services Administration, Federal Supply Service, Washington, DC or from Business Service Center of the nearest GSA Regional Offices.

A-A-3113

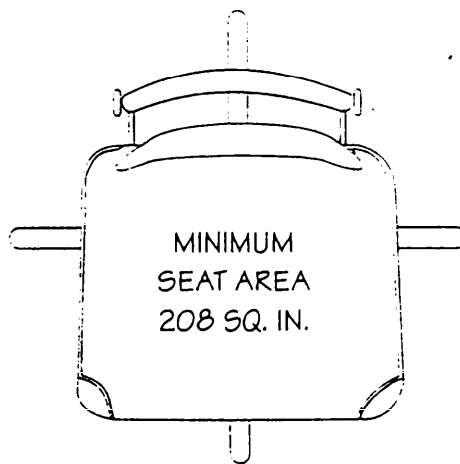
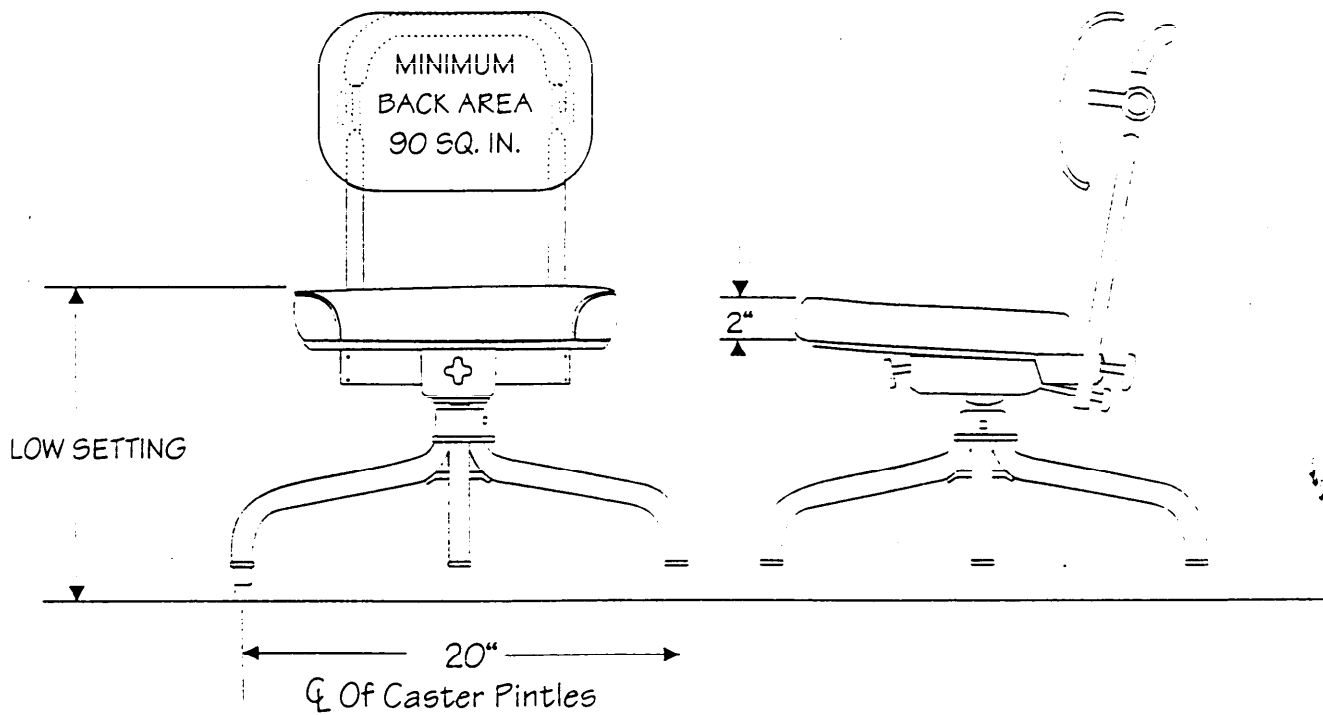

All dimensions are minimum

Class I
Size 1

A-A-3113

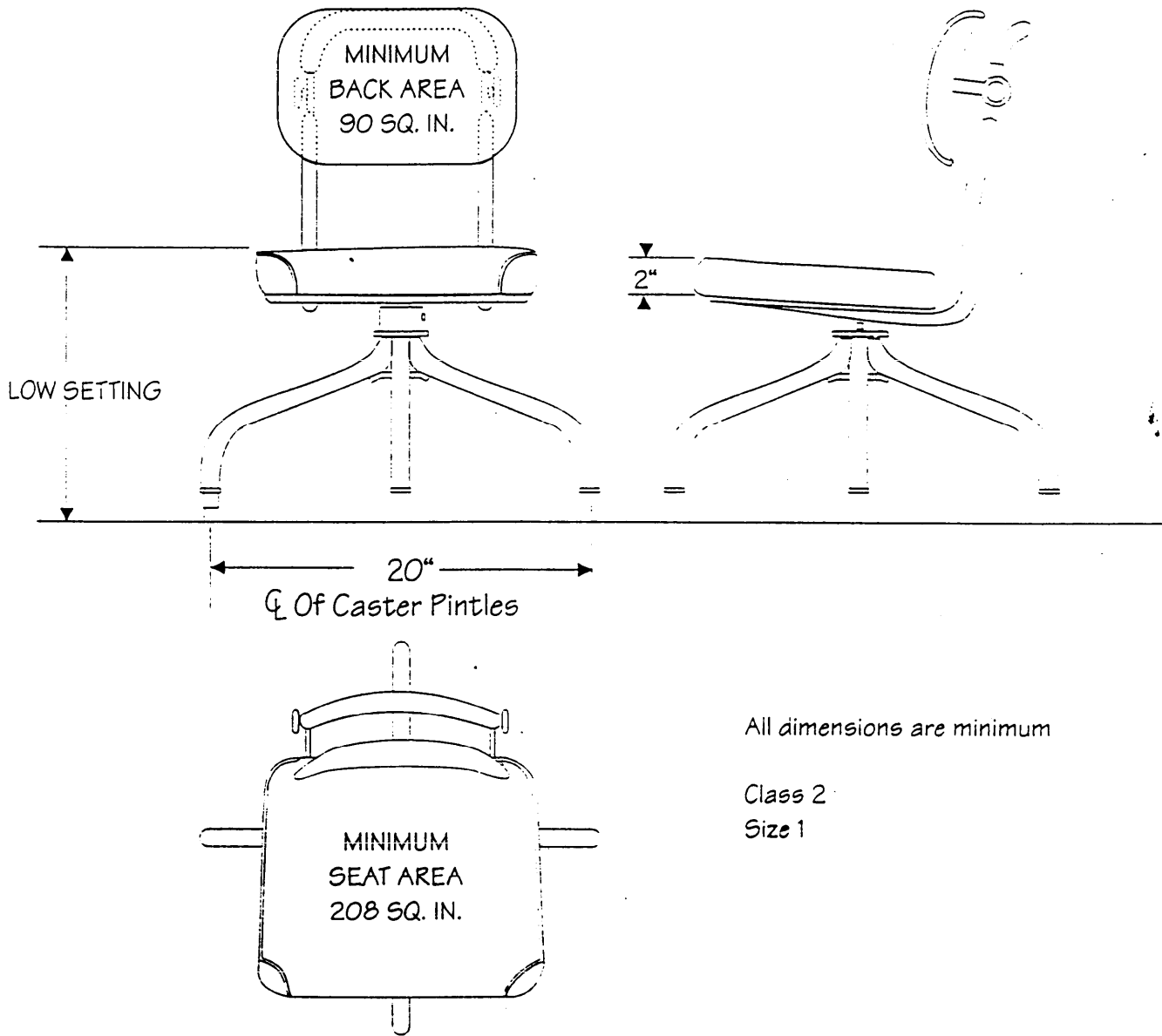

A-A-3113

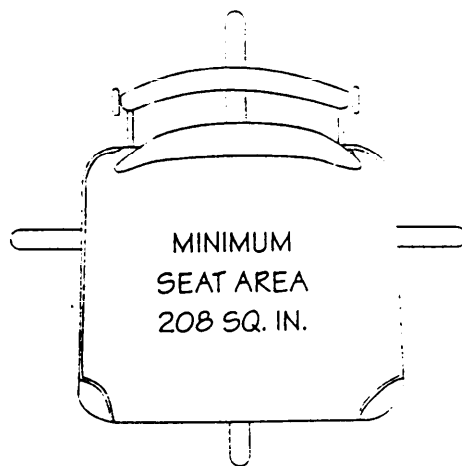
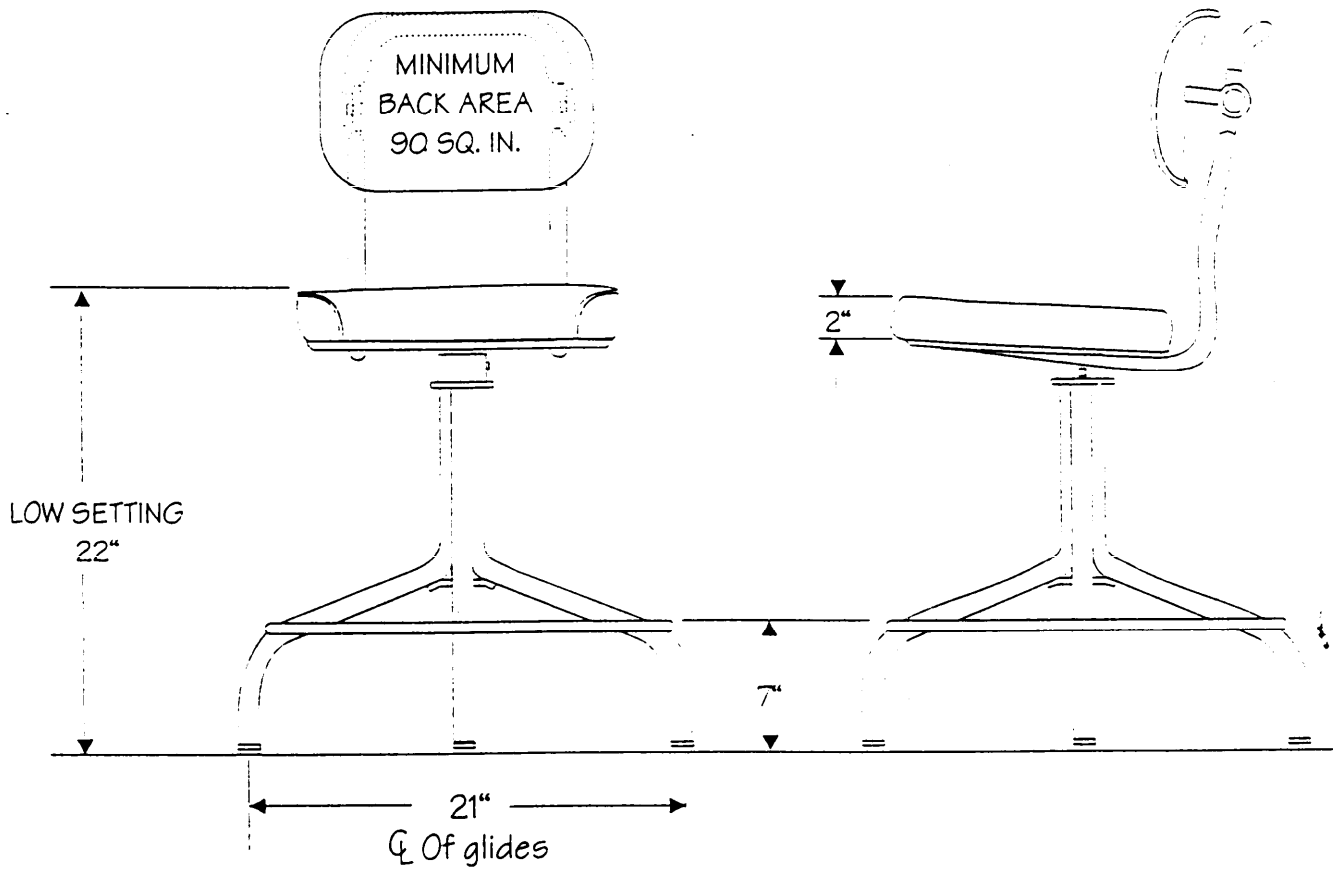

All dimensions are minimum

Class 2

Size 2

A-A-3113

