

[INCH-POUND]  
A-A-3091  
October 30, 1996

## COMMERCIAL ITEM DESCRIPTION

### CHISELS, COLD, POWER HAMMER

The General Services Administration has authorized the use of this Commercial Item Description for the procurement of type VII, class A and B chisels specified in GGG-C-330 for all federal agencies.

#### 1. SCOPE.

1.1 Scope. This Commercial Item Description covers cold chisels used in pneumatic chipping hammers for cutting metal.

#### 2. CLASSIFICATION.

2.1 Classification. This Commercial Item Description shall be of the following classes:

- Class A - Carbon steel
- Class B - High-speed steel

#### 3. SALIENT CHARACTERISTICS.

3.1 Design. The cold chisels shall be designed for use with pneumatic chipping hammers for cutting metal. The tool shall consist of a body and shank. The cold chisel shall be forged of either class A carbon steel, or class B high-speed steel (see 7.2), and shall be similar to Figure 1.

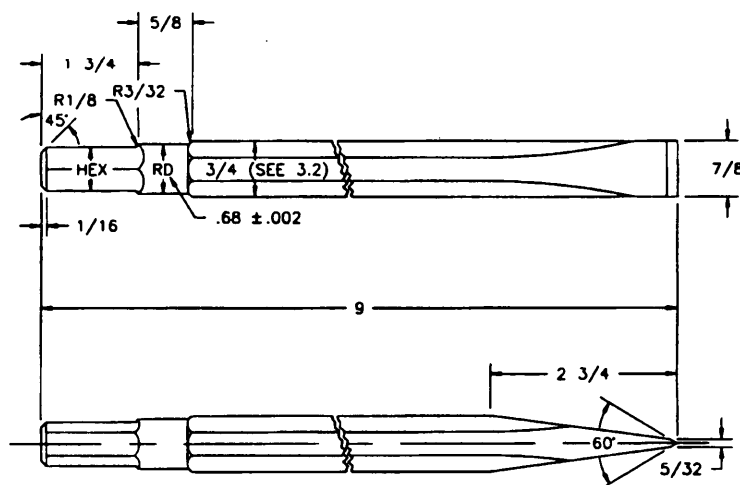

Figure 1. Chisel, cold, power hammer.

Beneficial comments, recommendations, additions, deletions, clarifications, etc., and any other data which may improve this document should be sent to: General Services Administration, Federal Supply Service, Tools and Appliances Commodity Center, Kansas City, MO 64131.

A-A-3091

3.2 **Body.** The body of the chisel shall have either a hexagonal, octagonal, round, or a modification of round shape.

3.3 **Shank.** The shank of the chisel shall be concentric and in proper alignment with the body of the chisel. The striking end of the shank shall be at a right angle to the longitudinal axis of the shank and shall be chamfered (see Figure 1). The shank shall be hexagonal. The distance across flats shall be  $0.580 \pm 0.002$  inch.

3.4 **Identification marking.** The tool shall be marked with the manufacturer's name or identifying symbol and the state or country of manufacture, unless otherwise specified. All identification markings shall be engraved, etched, molded, or indented directly on the item's surface in such a manner that it remains clearly legible throughout the life of the item.

3.5 **Workmanship.** Details of workmanship shall be in accordance with the best commercial practice. Paints, coatings, platings, and finishes shall be smooth, adherent, continuous, and not stained or discolored. External surfaces shall be free of tool and gouge marks, nicks, or other surface imperfections. The item shall be free from manufacturing workmanship defects (e.g., sharp or rough external edges, corners, or surfaces) and material workmanship defects (e.g., pits, rips, fins, burrs, tears, nodules, cracks, blisters) which may adversely impact the item's serviceability, durability, safety, or appearance.

#### 4. REGULATORY REQUIREMENTS.

4.1 **Recovered materials.** The offeror/contractor is encouraged to use recovered materials to the maximum extent practicable, in accordance with paragraph 23.403 of the Federal Acquisition Regulation (FAR).

4.2 **Metric products.** Products manufactured to metric dimensions will be considered on an equal basis with those manufactured using inch-pound units, provided they fall within the tolerances specified (using conversion tables contained in the latest revision of Federal Standard 376) and all other requirements of this document are met. If a product is manufactured to metric dimensions and those dimensions exceed the tolerances specified in the inch-pound units, a request should be made to the contracting officer to determine if the product is acceptable.

4.3 **Material certification.** The supplier shall furnish certified test data for the chemical composition of each batch or lot used in the fabrication of the chisel.

4.4 **Hardness.** The chisel shall have a hardness on the Rockwell C scale as specified in Table I in accordance with ASTM E18.

TABLE I. Rockwell Hardness

Class	Tool point	Striking end
A	58 to 61	45 to 55
B	59 to 62	45 to 55

#### 5. QUALITY ASSURANCE PROVISIONS.

5.1 **Product conformance.** The product provided to the Government shall conform to the contractually specified requirements. For product characteristics and requirements which are not contractually specified, the provided product shall conform to the producer's own drawings, standards, specifications, and quality assurance practices for the highest quality product commercially offered by the producer. If the product is not commercially offered by the producer, the best commercial practices shall apply. The Government reserves the right to require proof of such conformance prior to first delivery and thereafter as provided for under the provisions of the contract.

5.2 Responsibility for inspection. Unless otherwise specified, the contractor is responsible for the performance of all inspection requirements and may use any commercial facilities (including the contractor's own facilities) suitable for performance of the inspection requirements, unless disapproved by the Government. The Government reserves the right to perform any inspections deemed necessary to assure the item conforms to the specified requirements.

5.3 Bid sample(s). When a bid sample requirement is specified in the solicitation, the bid sample(s) shall be inspected for all salient characteristics by the Government. A failure of any bid sample to meet the salient characteristics shall be cause for rejection.

5.4 First article sample(s). When a first article requirement is specified in the contract, the first article sample(s) shall be inspected for all salient characteristics. A failure of any first article sample to meet the salient characteristics shall be cause for rejection.

## 6. PACKAGING.

6.1 Packaging. Requirements of preservation, packing, packaging, and marking of packages shall be as specified in the contract or order.

## 7. NOTES.

(This section contains information of a general or explanatory nature that is not mandatory.)

### 7.1 Addresses for obtaining copies of referenced documents:

Federal Specifications and Standards: Federal Supply Service Bureau, Specification Section, Suite 8100, 470 L'Enfant Plaza, SW, Washington, DC 20407.

Federal Acquisition Regulations (FAR): Government Printing Office, Superintendent of Documents, Washington, DC 20402-9371.

ANSI/ASQC Z1.4: American Society for Quality Control, P.O. Box 3005, 611 East Wisconsin Avenue, Milwaukee, WI 43201-4606.

ASTM E18: American Society for Testing and Materials, 100 Barr Harbor Drive, West Conshohocken, PA 19428-2959.

7.2 Ordering data. Purchasers should select the preferred options permitted herein and should include the following information in procurement documents:

- (a) Title, number, and date of this Commercial Item Description.
- (b) When applicable, the appropriate NSN(s).
- (c) When applicable, the specific class, as specified in the Commercial Item Description (see 2.1).
- (d) If bid samples are required, the number of samples required, and the subjective inspection requirements.
- (e) If first article samples are required and the number of samples required.
- (f) If lot sampling inspection is required and the applicable lot sampling requirements. For example:

Sampling for inspection. Sampling for inspection (both examinations and testing) shall be in accordance with ANSI/ASQC Z1.4.

Inspection. Each sample tool shall be examined and tested for all salient characteristics. The Inspection Level shall be S-2 with an Acceptable Quality Level of 4.0, expressed in terms of defects per hundred units.

- (g) What preservation, packing, packaging, and marking of packages are required.

A-A-3091

7.3 National Stock Numbers (NSNs). The following list of NSNs corresponds to the classes specified in this CID. This list may not be indicative of all possible NSNs associated with this CID.

NSN

5130-00-203-6428

MILITARY INTERESTS:

NONE: DoD has no registered interest in revisions or notices to this Commercial Item Description until further notice.

PREPARING ACTIVITY:

GSA - FSS