

REPORT DOCUMENTATION PAGE				Form Approved OMB No. 0704-0188	
The public reporting burden for this collection of information is estimated to average 1 hour per response, including the time for reviewing instructions, searching existing data sources, gathering and maintaining the data needed, and completing and reviewing the collection of information. Send comments regarding this burden estimate or any other aspect of this collection of information, including suggestions for reducing this burden, to Department of Defense, Washington Headquarters Services, Directorate for Information on Operations and Reports (0704-0188), 1215 Jefferson Davis Highway, Suite 1204, Arlington, VA 22202-4302. Respondents should be aware that notwithstanding any other provision of law, no person shall be subject to any penalty for failing to comply with a collection of information if it does not display a currently valid OMB control number. PLEASE DO NOT RETURN YOUR FORM TO THE ABOVE ADDRESS.					
1. REPORT DATE (DD-MM-YYYY) 12-02-2009		2. REPORT TYPE Final		3. DATES COVERED (From - To)	
4. TITLE AND SUBTITLE Test Operations Procedure (TOP) 7-3-537 Aircraft Natural/Artificial Icing				5a. CONTRACT NUMBER	
				5b. GRANT NUMBER	
				5c. PROGRAM ELEMENT NUMBER	
6. AUTHORS				5d. PROJECT NUMBER	
				5e. TASK NUMBER	
				5f. WORK UNIT NUMBER	
7. PERFORMING ORGANIZATION NAME(S) AND ADDRESS(ES) US Army Aviation Technical Test Center Flight Test Directorate (TEDT-AC-FT) Building 30601, Peters Street, Cairns Army Airfield Fort Rucker, AL 36362-5276				8. PERFORMING ORGANIZATION REPORT NUMBER TOP 7-3-537	
9. SPONSORING/MONITORING AGENCY NAME(S) AND ADDRESS(ES) Test Business Management Division (TEDT-TMB) US Army Developmental Test Command 314 Longs Corner Road Aberdeen Proving Ground, MD 21005-5055				10. SPONSOR/MONITOR'S ACRONYM(S)	
				11. SPONSOR/MONITOR'S REPORT NUMBER(S) Same as item 8	
12. DISTRIBUTION/AVAILABILITY STATEMENT Approved for public release; distribution unlimited.					
13. SUPPLEMENTARY NOTES Defense Technical Information Center (DTIC), AD No.: ADA503060					
14. ABSTRACT This TOP outlines the procedures and safety measures required to determine the ability of an aircraft to operate in icing conditions and the methodology involved in quantifying the effects of icing on aircraft handling qualities and performance.					
15. SUBJECT TERMS Rotary-Wing Aircraft Fixed-Wing Aircraft Icing Anti-ice Anti-icing Deice Deicing Helicopter Icing Spray System HISS					
16. SECURITY CLASSIFICATION OF:			17. LIMITATION OF ABSTRACT	18. NUMBER OF PAGES 76	19a. NAME OF RESPONSIBLE PERSON
a. REPORT Unclassified	b. ABSTRACT Unclassified	c. THIS PAGE Unclassified			19b. TELEPHONE NUMBER (include area code)

Standard Form 298 (Rev. 8-98)

Prescribed by ANSI Std. Z39-18

US ARMY DEVELOPMENTAL TEST COMMAND
TEST OPERATIONS PROCEDURE

*Test Operations Procedure 7-3-537
DTIC AD No.: ADA503060

12 February 2009

AIRCRAFT NATURAL/ARTIFICIAL ICING

	<u>Page</u>
Paragraph 1. SCOPE.....	2
2. FACILITIES AND INSTRUMENTATION.....	2
2.1 Facilities	2
2.2 Instrumentation.....	10
3. REQUIRED TEST CONDITIONS.....	11
3.1 General	11
3.2 Artificial Icing.....	14
3.3 Natural Icing.....	14
4. TEST PROCEDURES	15
4.1 General	15
4.2 Artificial Icing Testing	19
4.3 Natural Icing.....	27
5. DATA REQUIRED.....	32
5.1 Baseline Data Required.....	32
5.2 Minimum Flight Test Data.....	33
5.3 New Deice/Anti-ice System Performance Data	33
5.4 Further Data.....	34
6. PRESENTATION OF DATA.....	34
APPENDIX A. ICING INSTRUMENTATION.....	A-1
B. ICING RISK ASSESSMENT	B-1
C. ICING TEST SITE SELECTION	C-1
D. ABBREVIATIONS.....	D-1
E. GLOSSARY	E-1
F. REFERENCES.....	F-1

TOP 7-3-537
12 February 2009

1. SCOPE.

This Test Operations Procedure (TOP) covers the procedures and methods for testing and evaluating aircraft handling qualities and performance in icing conditions. Ice buildup on aircraft can have detrimental effects: degraded engine performance, reduced aerodynamic efficiency by changing airfoil shapes, significant physical damage from ice shedding off rotating and/or non-rotating components, etc. Some aircraft are unsafe to operate in any icing conditions, while others are equipped to fly in significant icing conditions with little handling qualities or performance degradation. This document outlines the procedures and safety measures required to determine the ability of an aircraft to operate in icing conditions and the methodology involved in quantifying the effects of icing on aircraft handling qualities and performance. This document presumes that a new aircraft or new ice protection systems are being evaluated. If modifications to existing ice protection systems and/or the aircraft are being evaluated, then the scope of testing and/or data required may be reduced.

2. FACILITIES AND INSTRUMENTATION.

2.1 Facilities.

2.1.1 Test Site Selection.

The test team's test site selection is critical to successful test execution. The team must carefully analyze the test objectives to determine the required meteorological conditions and then identify geographical locations that have historical weather patterns and statistics that meet these requirements. The test site selection is then based on availability of suitable airfields and airspace for test operations. Additionally, test objectives may require more than one set of test conditions be met (i.e., artificial and natural icing tests may be flown in conjunction with hovering in recirculating snow and flight in low-visibility, falling-snow conditions), which may result in additional compromises in the site selection process.

The team must identify a suitable host airfield early in the planning phase. Arrangements for hangar space, snow removal, logistic/maintenance support, office space, phone/computer hookups, etc., need to be in place well in advance of the testing date(s). A site pre-visit is essential to confirm that airfield management and air traffic control (ATC) authorities understand the implications of hosting an icing test and are prepared to enter into an agreement for nonstandard maneuvering, nonstandard recoveries, and military assumes responsibility for separation of aircraft (MARSAs) procedures. If the test scope includes testing in low visibilities due to falling/recirculating snow, ATC must agree to visual flight and recovery operations below visual flight rules/special visual flight rules (VFR/SVFR) minima.

To reduce the risk of damaging property or injuring personnel from possible system under test (SUT) (i.e., test aircraft), ice shedding during recovery to the airfield, a safe flight corridor/route and ramp recovery/parking locations must be coordinated. The team should conduct a site safety survey to establish key points of contacts and emergency procedures relevant to the test location. A more detailed discussion of icing test site selection is presented in appendix A.

2.1.2 Test Support Equipment and Personnel.

Recommended minimum test support personnel and equipment is presented in table 1.

Table 1. Minimum Recommended Test Support List

Item	Comments
Test Aircraft	Instrumented as required
JRC-12G Airborne Cloud Measuring Equipment (ACME) System	Document natural icing conditions and perform chase and photographic documentation
JCH-47D Helicopter Icing Spray System (HISS)	As required for artificial icing
JUH-60M HISS Cloud Characterization System (CCS)	Document artificial icing conditions
Chase/Crash Recue Aircraft	As required
Aircraft Maintenance Support	As required
Aircraft Operational Support	Standard unit support equipment
Aircraft Weighing Equipment	To determine aircraft weight and center of gravity (cg)
Secured Ballast (if required)	To vary the aircraft weight/cg
Stopwatch	Manual recording of immersion times
Still/Video Equipment	Photo/video documentation of icing effects on SUT
Equipment to measure aircraft environmental conditions	To document actual test conditions (may be on the test or on an independent, instrumented aircraft)
Equipment to monitor critical parameters in real-time	To provide early warning of exceedance (may be on the SUT or may be telemetered to a monitoring station)
Test Personnel	Aircraft crew(s), data collection and processing personnel, engineering/analysis personnel, maintenance and logistics personnel
Test Personnel Equipment	Applicable cold weather/survival gear

TOP 7-3-537
12 February 2009

2.1.3 Helicopter Icing Spray System.

The helicopter icing spray system (HISS) as shown in Figure 1 is part of a modified CH-47D helicopter operated as an airborne spray tanker to create an artificial cloud used in icing qualification tests. The HISS can produce simulated rain or icing conditions at indicated airspeeds between 80 and 130 knots at altitudes from 1,500 ft above ground level (AGL) to 10,000 ft pressure altitude (PA). The icing simulation equipment is capable of spraying water at a maximum rate to produce an average liquid water content (LWC) cloud in excess of 3.0 grams per cubic meter (g/m^3) down to a minimum of $0.25 \text{ g}/\text{m}^3$. Flow rates can be controlled with 10% accuracy from the maximum to minimum flow. Typical artificial icing test conditions range from 0°C to -25°C temperatures and 0.25 to $1.0 \text{ g}/\text{m}^3$ LWC clouds.

The installed HISS equipment consists of a trunnion assembly and spray booms installed on a pallet-mounted support assembly and an 1,800-gallon capacity water tank installed in a pallet-mounted cradle. Water from the tank is pumped through a separate tube, located within the spray booms, to the atomizers. Bleed air from the two HISS auxiliary power units (APUs) is ducted internally through the spray booms around the water tubes to the atomizers. Proximity of the hot bleed air to the water tube minimizes the possibility of the water freezing in the tube. When in operation, the spray boom assembly extends below the aircraft fuselage approximately 19 ft.

Hydraulic actuators rotate the torque tube to raise or lower the boom assembly while mechanical latches hold the boom assembly in either the fully deployed or retracted positions. Both the external boom assembly and the internal water can be jettisoned in an emergency. To provide visual cues to the SUT for maintaining a known standoff distance, the HISS has aft-facing radar altimeter antennas mounted at the rear which activate red, yellow, and green lights on the bottom of the fuselage providing visual cues of distance and of aircraft closure rate.

The HISS has a minimal amount of installed instrumentation. A calibrated Rosemount air temperature probe and an EG&G model 137-C3 dew point hygrometer with cockpit displays provide accurate ambient temperature and humidity measurements. The HISS instrumentation displays; upper/lower boom water pressure, water pump pressure, hydraulic pressure to the operator. Since the HISS does not have any recording equipment installed, all measurements are read and recorded manually. Technical Note, ATTC TN 90-01, Operation and Maintenance Procedures for CH-47 Helicopter Icing Spray System^{1*}, contains more information on the HISS.

* Superscript numbers correspond to those in Appendix F, References.

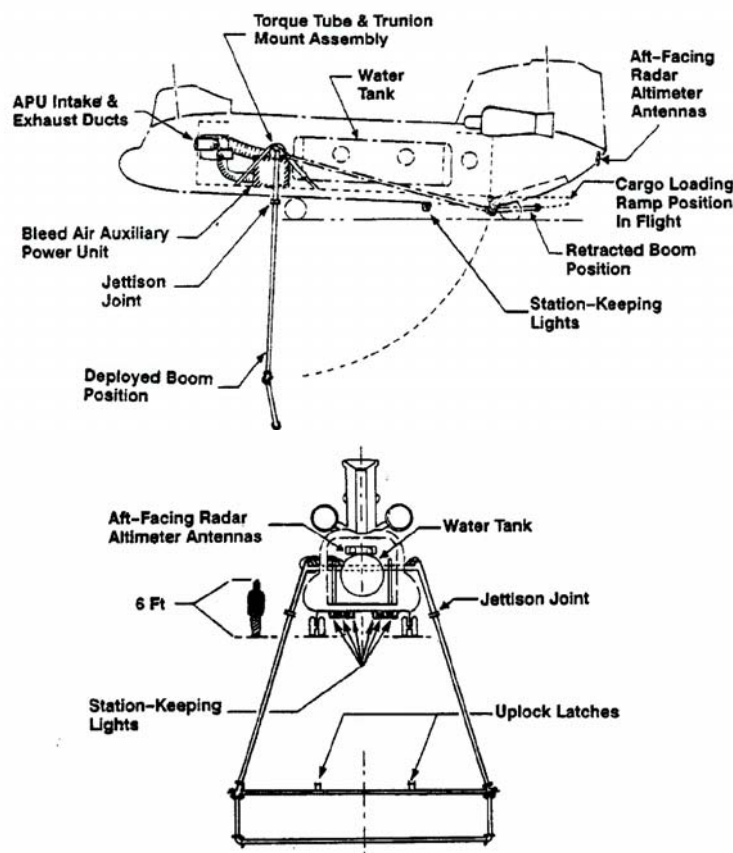

Figure 1. Helicopter Icing Spray System

2.1.4 JRC-12G ACME Cloud Sampling and Chase Aircraft.

A JRC-12G Guardrail twin turboprop aircraft (U.S. Army serial number (ASN) 80-23380) as shown in Figure 2 has been specially modified to measure cloud conditions in both natural and artificial (HISS) environments. The aircraft is equipped with a cloud physics data collection system and instruments for cloud characterization. The airframe is modified by installation of hardened aluminum panels on the forward fuselage for preventing damage from propeller ice shedding. Modifications to configure the JRC-12G for icing test support missions include installation of the following items:

a. On the nose of the aircraft:

- (1) Rosemount total temperature probe, Model 102AU2CK.
- (2) Any two of the following: Science Engineering Associates, Inc., (SEA) liquid water content (LWC) probe, Model MLWC-1000; SEA LWC probe, Model MLWC-2000; Particle Metrics, Inc. (PMI), CSIRO-KING LWC probe, Model KLWC-5, Cloud Technology, Inc. (CT) LWC probe.

b. On the right wingtip mount:

- (1) Cambridge (EG&G International) dew point sensor, Model 137-A20.

TOP 7-3-537
12 February 2009

(2) Particle Measuring Systems, Inc. (PMS) forward-scattering spectrometer probe (FSSP), Model FSSP-100.

(3) PMS optical array probe (OAP), Model OAP-200X.

c. On the left wingtip mount:

(1) PMS FSSP, Model FSSP-100-ER.

(2) Either of the following: PMS OAP, Model OAP-2DGA2; Droplet Measurement Technology (DMT) cloud aerosol spectrometer (CAPS) probe.

d. Interior cockpit/cabin:

(1) SEA portable 6-in. pilot display mounted on the center console.

(2) SEA computer hardware/software package, Model M300, with associated wiring and power distribution unit, installed in the forward cabin (left side).

(3) A locally manufactured equipment rack, located aft of the mission equipment power distribution panel in the forward cabin (right side), housing the Cloud Technology, Inc., LWC meter, SEA LWC meter, PMI LWC meter, Cambridge dew point meter, sensor heater controls, and instrumentation circuit breakers and power switches.

(4) Four cabin radio/interphone communication system boxes.

e. Exterior cockpit:

(1) Aeroplane & Armament Experimental Establishment (now Defense Evaluation and Research Agency) vernier accretion meter (“Harvey Smith”)

(2) Small airfoil section probe (an OH-6 tail rotor section attached to a metal framework)

f. The computer system is the third generation and is termed ACME-3. The ACME-3 was developed by SEA of Mansfield Center, CT. The ACME-3 consists of the SEA Model 300 data acquisition system, keyboard and track-ball mouse, flat panel display at the engineer station, and a 6-in. flat panel display on the center console between the pilot and copilot seats. Data can be transferred to ground station computers for storage through USB flash drives. A complete description of the SEA Model 300 is contained in the user’s manual (available at www.scieng.com). The following parameters are provided by the ACME-3 instrumentation data package for icing qualification tests:

(1) Year, month, day, hour, minutes, seconds.

(2) Pressure altitude (ft).

(3) Density altitude (ft).

- (4) Indicated airspeed (kt).
- (5) True airspeed (kt).
- (6) Total air temperature (°C and °F).
- (7) Static air temperature (°C and °F).
- (8) Dew point temperature (°C and °F).
- (9) Frost point temperature (°C and °F).
- (10) Relative humidity (%).
- (11) SEA ice detector LWC (g/m³).
- (12) PMI King ice detector LWC (g/m³).
- (13) Individual FSSP-100, FSSP-100-ER, OAP-200X, and OAP 2DGA2 computations of total LWC (g/m³).
- (14) Individual FSSP-100, FSSP-100-ER, OAP-200X, and OAP 2DGA2 computations of median volumetric diameter (microns).
- (15) Individual and combined Cloud and Aerosol Spectrometer (CAS) and Cloud Imaging Probe (CIP) computations of total LWC (g/m³).
- (16) Individual and combined CAS and CIP-2D computations of MVD (microns).
- (17) Amount of LWC observed for each channel (total 15) of the FSSP-100 probe (3-micron resolution).
- (18) Amount of LWC observed for each channel (total 15) of the OAP-200X probe (20-micron resolution).
- (19) Amount of LWC observed for each channel (total 15) of the FSSP-100-ER probe (6-micron resolution).
- (20) Amount of LWC observed for each channel (total 30) of the OAP-2DGA2 probe (20-micron resolution).
- (21) Amount of LWC observed for each channel (total 30) of the CAS probe (variable 0.07- to 5-micron resolution).
- (22) Amount of LWC observed for each channel (total 62) of the CIP probe (25-micron resolution).
- (23) Real-time, two-dimensional image display of water droplets, ice crystals, etc. from either the OAP 2DGA2 or CAPS probe.

TOP 7-3-537
12 February 2009

(24) Global positioning system information for real-time display of aircraft position (total 30) of both spectrometer probes.

All the cloud parameters are computed from particle number count and size classification from the PMS probes and size of air volume sampled. A measured water particle (drop) is assumed to lie at the top of its size class, although actual diameter may fall anywhere within the channel width (leading to errors in LWC computation). The computation does not include the two smallest channels of the OAP-200X (20 and 40 micron channels) since they overlap the size range covered by the FSSP-100. Median volumetric diameter (MVD) is the drop size which divides the volume of the spray in halves, such that half the total water volume is contained in drops larger than the median diameter and half in drops smaller than this median diameter. The standard ACME-3 data averaging intervals (sample accumulation rate) used are 10 seconds for natural icing and 1 second for HISS cloud calibrations.

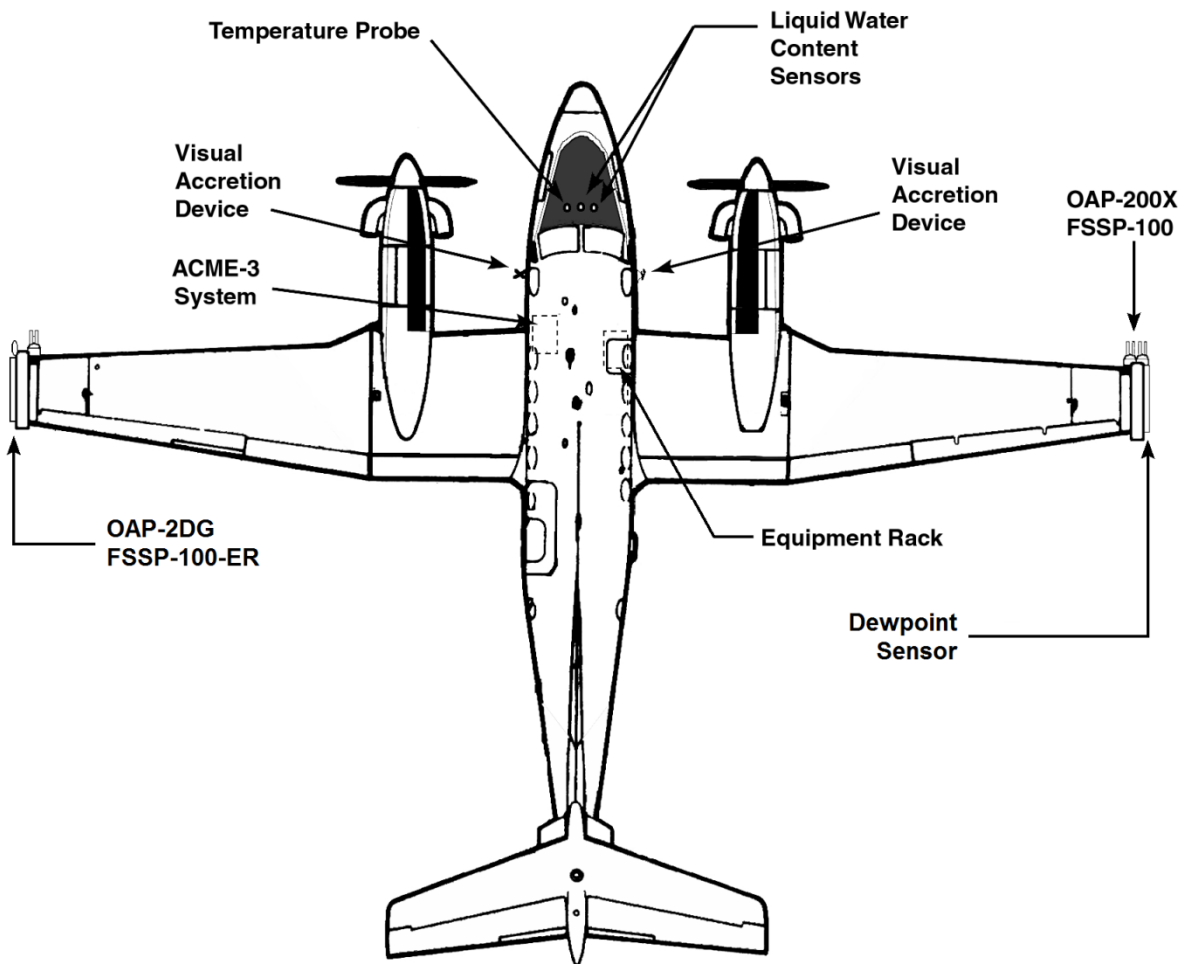

Figure 2. General Arrangement of JRC-12G Modified for Icing Tests.

2.1.5 JUH-60M Cloud Characterization System (CCS) and Chase Aircraft.

A UH-60M Black Hawk helicopter (ASN 02-26978), as shown in Figure 3, has been configured with an external tank system (ETS) wing mounted on the right side of the aircraft to support instrumentation for cloud characterization. For the CCS mission, the UH-60M has the following equipment installed:

- a. On the ETS wing mounted in the right side of the aircraft:
 - (1) Cambridge (EG&G International) dew point sensor, Model 137-A20.
 - (2) Particle Measuring Systems (PMS), Inc., forward-scattering spectrometer probe (FSSP), Model FSSP-100.
 - (3) PMS optical array probe (OAP), Model OAP-200X.
 - (4) Either of the following: PMS OAP, Model OAP-2DGA2; DMT CAPS probe; DMT CCP probe.
- b. Interior cockpit/cabin:
 - (1) SEA computer hardware/software package, Model M300, with associated wiring and power distribution unit.
 - (2) A locally manufactured equipment rack, located in the center of the aft cabin, housing the M300, SEA MLWC-2000 controller, Cambridge dew point meter, sensor heater controls, and instrumentation circuit breakers and power switches, and large monitor for display of parameters.

The installed instrumentation and M300 function are a duplicate of those installed in the JRC-12G ACME aircraft. The UH-60M CCS was developed to overcome two JRC-12G operational limitation: the JRC-12G was restricted from operating directly behind the JCH-47D HISS during cloud sampling and the JRC-12G was limited to ~105 knots or higher to reduce risk of stall.

TOP 7-3-537
12 February 2009



Figure 3. UH-60M Configured for Icing Tests

2.2 Instrumentation.

Test objectives, test directive/request, and time available will dictate the level of instrumentation installed on the SUT. Instrumentation may vary from using aircraft instruments, a stopwatch, and handheld video/photographic equipment to adding such items as LWC and MVD sensors, vernier accretion meter, cameras, and sensitive flight instrumentation, and onboard data recorder to the aircraft. Regardless of the instrumentation configuration, a means to collect the data listed in table 2 (Minimum Data Requirements) must be available. Table 3 lists additional instrumentation/data that should be considered in addition to those listed in table 2. The JRC-12G ACME system provides a test instrumentation capability specifically designed to collect cloud measurements (items in table 2) during both natural and artificial icing testing. A description of basic icing measuring devices is presented in appendix A (Icing Instrumentation).

Table 2. Minimum Data Requirements

Devices for Measuring	Measurement Accuracy
Free air temperature	$\pm 1^{\circ}\text{C}$
Liquid water content	$\pm 0.01 \text{ g/m}^3$
Droplet size	$\pm 3 \text{ micron}$
True airspeed	$\pm 1 \text{ kt}$
Observed airspeed	$\pm 1 \text{ kt}$
Aircraft pressure altitude	$\pm 20 \text{ ft}$
Ice accumulation	$\pm 0.01 \text{ in.}$
Time	$\pm 1 \text{ sec}$
Gross weight	$\pm 10 \text{ lb}$
Longitudinal cg	$\pm 0.1 \text{ in.}$

Table 3. Additional Data Requirements

Devices for Measuring	Measurement Accuracy
Barometric pressure	± 0.01 in. Hg
Vibrations (airframe or component)	relevant frequencies
Engine air inlet pressure delta	± 0.1 psig
Turbine gas temperature or equivalent	$\pm 5^{\circ}\text{C}$
Torque	$\pm 1\%$
N_g or equivalent	$\pm 0.1\%$
Angle of attack	$\pm 0.5^{\circ}$
Angle of sideslip	$\pm 0.5^{\circ}$
Fuel used	± 10 lb
Fuel flow	$\pm 1\%$ of total flow rate
Flight control positions	$\pm 1\%$ of full travel
Stability augmentation equipment positions and status	$\pm 1\%$ of full travel
Aircraft attitudes	± 1 deg
Aircraft rates	± 5 deg/sec
Anti-ice/deice status	ON/OFF
Anti-ice/deice electrical parameters	As appropriate
Anti-ice/deice component temperatures	$\pm 2^{\circ}\text{C}$
Generator voltages and currents	As appropriate
Bleed air pressures	As appropriate

3. REQUIRED TEST CONDITIONS.

3.1 General.

Qualification of an aircraft for operation in moderate icing conditions is a subjective action due to the varying definitions of icing used throughout industry and the military. The challenge in developing an icing test plan is the artificial icing test portion can be well-defined as test conditions in a detailed test matrix (specific temperature, artificial cloud LWC, airspeed, etc.) while the natural icing test conditions are usually defined by a desired range/envelope for testing. Additionally, since meteorological conditions vary daily, as well as annually, test day conditions may not be precisely those defined in the planned test matrix. Therefore, natural icing tests require more judgment on the part of the test team to ensure that testing is adequate to recommend an aircraft operational envelope for icing conditions.

TOP 7-3-537
12 February 2009

As with any test, the test matrix should include a buildup methodology with artificial icing testing, using the HISS, before testing in natural icing conditions. The artificial icing testing objective is to evaluate a range of test conditions broad enough to gain confidence in the aircraft systems' abilities to cope with the icing environment before conducting flight tests in natural icing conditions. In general, buildup should be from low to high LWCs and from warmer to colder temperatures.

3.1.1 Icing Intensity Definition.

Aircraft ice accretion results from the tendency of cloud droplets to remain in a liquid state at temperatures below freezing, a condition called supercooling. Typical temperature ranges for supercooled liquid cloud droplets are from 0°C to -30°C, with liquid water being rare at temperatures below -25°C. LWC is the term used to describe the amount of supercooled water droplets in clouds. The actual definition of LWC is the total mass of water contained in all the liquid cloud droplets within a unit volume of cloud, excluding water in vapor form and is usually stated in grams of water per cubic meter of air. Typical ranges of LWC are 0.1 to 0.8 g/m³ for stratiform clouds and 0.2 to 2.5 g/m³ for cumuliform clouds. The drop size distribution in the cloud is usually expressed in terms of median volumetric diameter. Median volumetric diameter (MVD) is the droplet diameter which divides the total water volume present in the droplet distribution half; i.e., half the water volume will be in larger drops and half the volume in smaller drops. The value comes from actual drop size measurements with units of microns (10⁻⁶ m). Typical natural cloud MVD is between 9 and 50 microns.

Icing intensities are usually categorized as trace, light, moderate, or severe (sometimes called heavy). Unfortunately, there is no general consensus on the definitions of these intensities. For this document, icing intensity is solely defined in terms of LWC without regard to temperature, droplet size, or subjective observations of ice accumulation. These definitions are:

- Trace – LWC below 0.15 g/m³
- Light – LWC between 0.15 and 0.49 g/m³
- Moderate – L C from 0.50 to 1.0 g/m³
- Severe – LWC in excess of 1.0 g/m³

3.1.2 Ice Types and General Effects.

Rime and glaze icing (Figure 4) are the two main types of icing encountered during testing. A third type, called intermediate, is really a combination of the other two. Rime ice is opaque and milky white in color with a generally rough texture. Glaze ice (sometimes called clear) is transparent with a smooth texture. Intermediate type ice (sometimes called mixed) is neither entirely rime nor glaze but has rime patches intermixed with glaze portions. Rime ice tends to form at colder temperatures, usually in clouds that have lower LWC and generally smaller droplets. Glaze ice forms when the temperature is closer to freezing, generally in clouds with higher LWC and slightly larger droplet sizes. Characteristically, rime ice forms in streamlined shapes that grow forward into the airstream, while glaze ice tends to form in broad shapes that create high aerodynamic drag as they expand laterally. The different types of ice are a result of how the drops freeze on a surface. Rime ice forms when the supercooled droplets in the cloud

freeze immediately on impact with the aircraft surface; trapped air gives the ice its milky white appearance. In the glaze ice case, the droplets do not freeze immediately on impact; instead, they either coalesce with other droplets to form much larger drops or they merge with a liquid film on the surface. Either way, the droplets tend to run back from the stagnation point before freezing causing a horned shape which is frequently referred to as a ram's horn. Since there is no trapped air, glaze ice is transparent.

The effect of ice on the aircraft tends to become more severe as the ambient air temperature increases above -26°C . Below -26°C the ice is more conformal and may not significantly degrade aircraft performance. At warmer temperatures, particularly in the -15°C to $+2^{\circ}\text{C}$ range, ram's head (glaze) icing accumulates which tends to have a cyclic process of ice building up then shedding. During shedding there is a risk of aircraft damage from impact, engine ice ingestion, and/or high vibrations induced from asymmetrical ice shedding from rotating components. Full rotor blade span ice accretion typically starts at -14°C to -16°C with possible significant accretions on the blade tips and associated risk of damage from tip shedding. Of less concern are even colder temperatures where the amount of LWC available in natural clouds to produce ice is limited.

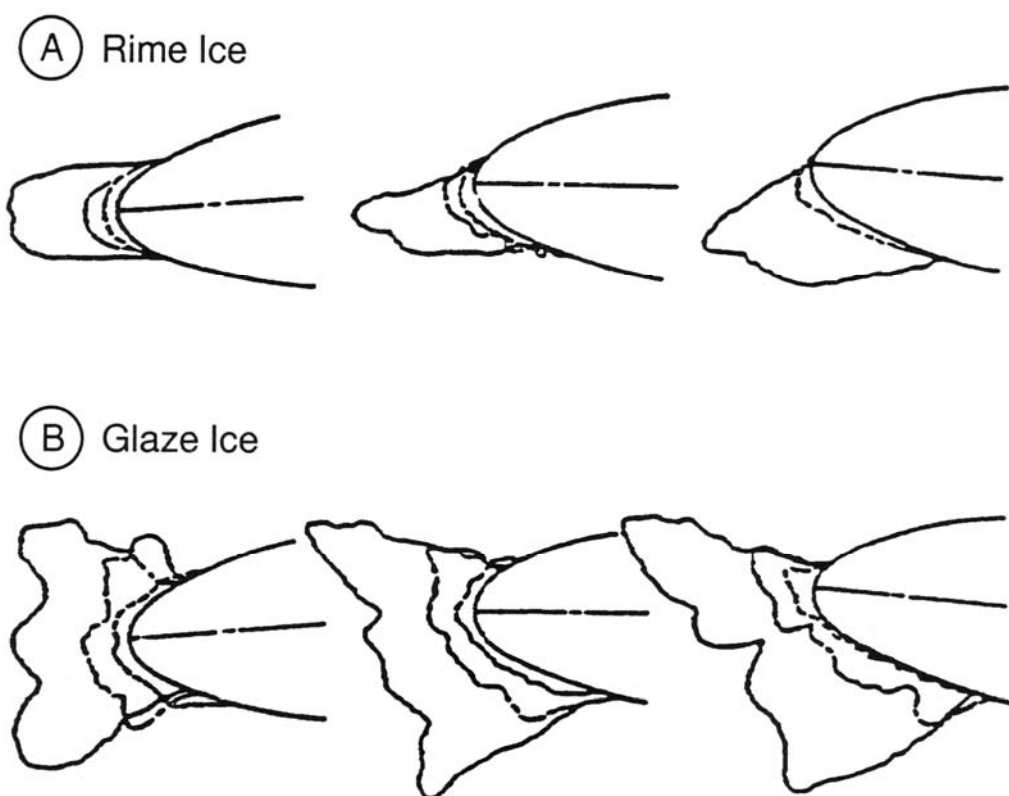

Figure 4. Representative Ice Formations on a Typical Airfoil Leading Edge

TOP 7-3-537
12 February 2009

3.2 Artificial Icing.

Artificial icing testing develops confidence in the ability of the aircraft and its anti-ice/deice systems to safely handle planned natural icing encounters. Currently, this testing is limited to a localized area on the aircraft due to the physical dimensions of the HISS spray rig cloud, whereas natural icing will result in the entire aircraft being immersed. In spite of this drawback, artificial icing tests are a prudent buildup to natural icing conditions since testing occurs in a controlled environment in visual meteorological conditions (VMC) and results may indicate potential unsafe natural icing conditions to be avoided. Using the HISS, the test team can evaluate an extensive range of temperatures (0° to -20°C) and LWC (0.25 to 1.0 g/m³) combinations. A typical artificial icing test matrix is presented in table 4.

Historically, initial aircraft icing qualification has included testing the full range of this matrix. Past experience has shown that the highlighted points in table 4 constitute the upper boundary of moderate intensity icing conditions that are likely to occur in either stratiform or cumuliform clouds below 10,000 ft. Unless directed otherwise, the darkened points in table 4 should be investigated along with any data points to the left that are deemed necessary for buildup. However, the actual test scope will be bounded by the direction/guidance from the airworthiness authority or the exact wording contained in the aircraft's prime item development specification.

Table 4. Recommended Artificial Icing Test Matrix

		Liquid Water Content (g/m ³)			
		.25	.50	.75	1.0
Temperature (°C)	-5				
	-10				
	-15				
	-20				

3.3 Natural Icing.

Natural icing is the primary source of data for qualifying an aircraft for operations in icing conditions. Gaps in natural icing data may be supplemented by artificial icing data if test results are comparable. Therefore, the primary test objective is to safely gather as much natural icing data as possible in the time available (weeks/months). An additional challenge in the planning process is to determine the flight time necessary to fully explore the natural icing regime necessary for certification. As a general guideline, at least 20 hours of productive flight testing in natural icing should be planned.

Additionally, the natural icing portion of the test matrix is more difficult to quantify and typically includes a range of “desired test conditions” with the understanding that actual test conditions could be significantly different. During testing, the team will have to evaluate weather conditions daily and determine if each day’s icing conditions are safe and exploitable based on test results to date and past experience. If natural icing tests are conducted concurrently with artificial icing, then typically the natural icing condition should not exceed the artificial icing envelope successfully explored.

Two visual phenomena may help in determining if natural icing conditions are present: the glory and the subsun (also called an undersun or sun dog). The glory is a colored disk similar to a rainbow which surrounds the shadow of an aircraft. It is caused by the refraction of light from small liquid water drops close to the spot opposite the sun. If a glory is present in clouds with temperatures below freezing, there will be supercooled liquid water drops in the cloud and hence icing conditions. When a glory is not seen in the anti-solar position (where the aircraft’s shadow appears), it is likely that a subsun will be visible in the direction of the sun. A subsun results from the reflection of light from large numbers of ice crystals. A subsun is seen in the direction of the sun at the same distance below the horizon as the sun is above the horizon. If a subsun is visible, then the water drops in the cloud have glaciated (frozen) and icing conditions are not present.

4. TEST PROCEDURES.

4.1 General.

4.1.1 Safety.

Icing tests are among the most complex and potentially dangerous of any flight test programs and require a careful, measured buildup approach. Artificial icing tests require coordination of up to four aircraft in various stages of formation flight; natural icing flights may require more than one aircraft but can involve autonomous aircraft operations in actual icing conditions. Training and experience, along with careful, thorough daily briefings, mitigate some of the risks; but a thorough hazard analysis and risk assessment is required (see icing hazard analysis in Appendix B).

4.1.2 Escape from Icing Conditions.

The team must always ensure the SUT has a means to expeditiously exit icing conditions. Typically, natural icing tests are flown at the top of a layer of stratus clouds, which allows the SUT to climb above the cloud layer to avoid further icing. However, if the cloud layer is thick, the pilot must account for the additional ice accumulation resulting from descending through the cloud layer during recovery to prevent exceeding any test limitations. Alternatively, a minimum cloud base or 2°C isotherm of 500 ft over water and 1,000 ft over land should provide a safe alternative to climbing on top of the cloud layer to exit icing conditions. (Note: Over the sea, even in cloud, ice formation rarely occurs below 500 ft due to the high salt content).

TOP 7-3-537
12 February 2009

4.1.3 Structural Considerations.

The team must evaluate the aircraft structure to determine whether any strengthening or reinforcement is required (e.g., on the fuselage, adjacent to propellers, to prevent ice penetrating the cockpit/passenger compartment due to shedding). Also, any component that penetrates the airflow is likely to collect ice (e.g., antennas). When ice forms on such components, their natural frequency changes, which may make them more vulnerable to structural damage.

4.1.4 Ice Shedding.

Ice is shed from aircraft in various ways, and a thorough examination and an analysis of the SUT are required to identify potential ice-shedding problems:

- a. Rotating components shed ice tangentially to the direction of rotation (e.g., ice can be shed forward from a tail rotor).
- b. Vibration tends to cause ice to be shed rearwards or outwards from the main rotor.
- c. Deicing of components can cause large pieces of ice to be shed, especially if deicing is delayed.
- d. Ice shedding from a heavily iced aircraft can be hazardous beyond 100 yards to aircraft in formation and people and property on the ground. After landing, personnel must not approach the SUT until rotors or propellers have stopped.
- e. Engines are vulnerable to damage from ingestion of shed ice. Intakes should be examined to determine vulnerability and protection fitted, if required. Caution must be used when fitting any screens as such devices must not restrict airflow and may prove susceptible to icing themselves.

4.1.5 Training.

A thorough training program is required before any icing test. The training required must be determined by analysis. The following topics should be considered:

- a. Survival Techniques. Everyone involved in a winter icing test is vulnerable to the weather. A thorough understanding of the dangers of wind-chill, frostbite, slipping/falling from snow or ice on the ground, etc., is required by all personnel.
- b. Instrument Flying. A high standard of instrument flying proficiency is required since the workload during an icing test is high.
- c. Formation Flying. The techniques required for effective icing testing, specifically when an artificial icing tanker aircraft is used, are complex and difficult. Training and rehearsals for the formation flying and formation changes with the JCH-47D HISS should be thorough to include emergency break-up and inadvertent IMC procedures as presented:

Emergency Formation Breakup Procedure

Any aircraft observing an in-flight emergency or dangerous condition during HISS spray operations will transmit the “BREAKAWAY....BREAKAWAY” command. Upon hearing or transmitting the command, the following action will be executed:

- JCH-47D pilots attempt to continue straight and level flight at constant airspeed and altitude for a minimum of 5 seconds.
- The JUH-60M or other chase aircraft turns 45-deg away from the formation and maintains altitude.
- The SUT descends and turns 45-deg away from the side the chase aircraft was located (i.e., if the chase aircraft is on the right side of the formation, the SUT descends and turns to the left, and vice versa).
- If the JCH-47D or SUT are experiencing an emergency, the JUH-60M or designated crash/rescue aircraft assists the aircraft with the emergency as necessary.
- If the UH-1H crash/rescue has an emergency, the HISS acts as chase for it.
- The UH-60M crew, if not experiencing the emergency, calls the test ground crew to alert them to the emergency and requests any necessary assistance from them.
- All aircraft will RTB, handling their own communications.

Emergency Inadvertent IMC Formation Breakup Procedure

In the event of entering IMC conditions during formation flight, any aircraft will call “Execute Inadvertent IMC Break-up – Execute Inadvertent IMC Break-up” Upon hearing this call the pilots will take the following actions:

- JCH-47D pilots accelerates 10 KIAS and begins a 500 fpm climb of 1,000 ft while maintaining a constant heading.
- The JUH-60M or other chase aircraft turns 45-deg away from the formation and maintaining a constant airspeed and altitude.
- The SUT descends and turns 45-deg away from the side the chase aircraft was located (i.e., if the chase aircraft is on the right side of the formation, the SUT descends and turns to the left, and vice versa) decelerates 10 KIAS and begins a 500 fpm descent for 1000 ft.
- All aircraft will contact local air traffic control and request IFR clearance back to the airfield or known VMC conditions.

d. Egress Drills. Egress drills should be conducted by all crewmembers in each type of aircraft they anticipate flying in. Egress drills should include the clothing and equipment expected to be used, e.g., parachutes. Heating may not be available for a particular test, resulting in the need for bulkier than normal clothing.

TOP 7-3-537
12 February 2009

e. Briefings. A briefing program should be developed to try to cover those subjects for which personnel have not been formally trained (e.g., winter driving techniques, etc.).

4.1.6 Pre-Test Actions.

a. Instrumentation. The test and supporting aircraft and ground station instrumentation systems (if installed) must be calibrated and functionally checked. Data reduction systems should be checked with data gathered from instrumentation functional check flights. Functional checks of icing sensors should be conducted in natural icing conditions.

b. Flight Controlling Agencies. Before conducting icing survey or test flights, the flight crews need to pre-coordinate the following with the local tower, approach/departure control, and center:

(1) Anticipated block airspace requirements for testing (typically between minimum vectoring altitude (MVA) and 12,000 ft).

(2) Test airspace areas that minimize interference with other IFR traffic and have navigational aid coverage to facilitate positioning SUT in desired weather conditions and support flight path selection (i.e., VORTAC radials with DME).

(3) Use of MARSA procedures, (Aeronautical Information Manual²) while flying an IFR flight plan in VMC when the test and chase aircraft are within 4 nm of each other.

(4) Use of available radar facilities for vectoring to and remaining within the icing environment and flight following.

(5) Normal and emergency recovery sites and procedures.

4.1.7 The following general procedures apply to all test flights:

a. All aircraft will remain in the hangar until all are ready to launch, except where cold-soaking is required as an alternate test objective.

b. Aircraft should be airborne as soon as possible after leaving the hangar. If precipitation is present and takeoff is delayed, deicing may be required; consideration should be given to returning all aircraft to the hangar for drying.

c. The SUT should record data before engine start (e.g., control throws, ambient atmospheric conditions, fuel states, etc.).

d. As required, record instrumentation during engine/rotor start.

4.2 Artificial Icing Testing.

Artificial icing testing must be conducted clear of clouds and precipitation, and the free-air temperature must equate to the desired test matrix point. The test matrix and test point progression will vary depending on the type of equipment or aircraft being tested. In practice, artificial icing test conditions should be approached incrementally from warmer to colder temperatures and from lower to higher LWCs. This approach is most applicable for testing new or modified anti-ice/deice systems. As the LWC in the HISS clouds increases, so does the ice accretion rate requiring shorter deice system-cycle times to keep protected components clear. As ambient temperature decrease, the heater-based deice system will require longer and longer heater-on time to break the bond between the ice and the protected components (i.e., rotor and propeller blades). Therefore, on a given day, the warmest previously untested temperature from the test plan matrix that is available between 1,500 ft above ground level or minimum vectoring altitude and 10,000 ft pressure altitude should be selected. At that temperature, the lowest LWC not previously tested should be tested. As a rule of thumb, the SUT should be flown in the cloud at selected test conditions for a minimum of 30 min for a main rotor immersion (helicopter) and 60 min for a fuselage immersion (fixed-wing and rotary-wing) or until reaching some other limiting condition.

A typical mission sequence follows.

4.2.1 Weather Check/Temperature/Relative Humidity Survey.

The team's first task is to obtain test day temperature and relative humidity data from surface to at least 10,000 ft PA at 500-ft intervals using the JRC-12G (Primary (pri)) or JUH-60M CCS (alternate (alt)). In addition to the M300 data acquisition system data collection, the test engineer should manually record temperature, frost point, and relative humidity values (see sample data card presented in Figure 5). The M300 data acquisition software incorporates correction factors and equations to calculate static temperature, dew-point, and relative humidity. If necessary, the data can be manually calculated from plots.

Immediately after completing the survey, the test engineer will transmit the atmospheric data to local test operations. The test director or designee will use the data to determine which, if any, artificial icing data points can be completed that day and their sequence. The test team will be briefed on the planned data point during the mission briefing.

- b. The SUT and JUH-60M aircraft will be preflighted in the hangar and towed out for engine start at designated time.
- c. After engine start, the JUH-60M crew will conduct a communications “commo” check on the prebriefed test operations frequencies with all SUT and ATTC local ground test operations.
- d. Once the commo check is completed and all aircraft are ready, the JCH-47D HISS crew will call the taxi instructions for a flight of three (SUT, JUH-60M, and themselves) to precoordinated departure point(s). If used, the JRC-12G will request their own taxi and takeoff instructions from ground control and the local tower.
- e. When all three aircraft are in position and ready for takeoff, the JCH-47D crew will contact tower and request a transponder code, departure control frequency (if available), and departure for a formation flight of three to the designated test area. The JCH-47D as flight lead will squawk “normal” and the remainder of the flight “standby.”
- f. After takeoff, the JCH-47D pilot establishes an 80 knots indicated airspeed (KIAS) climb at 80% torque to expedite the climb to desired test altitude.
- g. As soon as safely possible after takeoff, the JCH-47D pilot will announce to the formation that the HISS boom will be in transit. At this time, the HISS operator will lower the HISS spray boom. This action alleviates lateral aircraft oscillations and structural fatigue associated with the boom in the stored position.
- h. The flight assumes a “V” formation with the JCH-47D as flight lead. The test and JUH-60M aircraft will position themselves outside of the diagonal created by a line passing through the near side rear wheel and far side forward wheel (Figure 6). These positions keep the aircraft properly separated and aids in avoiding the CH-47 wake turbulence. Once in proper formation, the JUH-60M crew will announce on the test frequency that all aircraft in the flight are airborne and the flight is formed.

TOP 7-3-537
12 February 2009

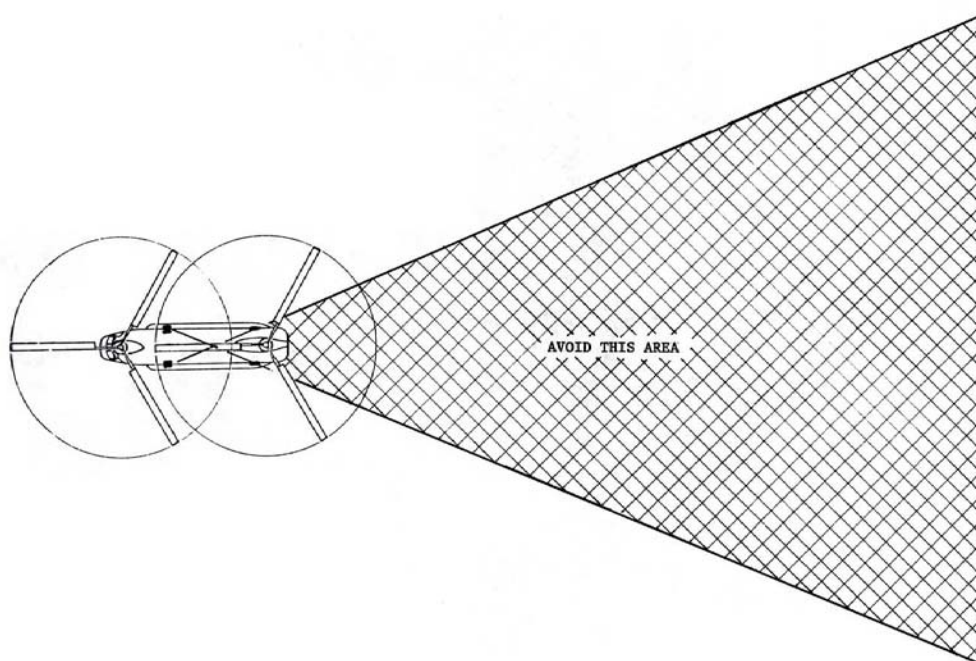

Figure 6. JCH-47D Avoid Area during Formation Flight

- i. The JCH-47D contacts departure control when directed.
- j. When the flight reaches the target test altitude and airspeed, the JRC-12G photo chase aircraft will join and maintain a pre-briefed distance position away and keep the flight in sight for the duration of the mission.

4.2.3 JCH-47D HISS Spray Cloud Calibration.

Once at the altitude for the desired outside temperature, HISS calibration is conducted as follows:

- a. The CH-47D crew verifies desired atmospheric conditions (temperature, pressure altitude, and relative humidity) and establishes desired airspeed.
- b. The HISS operator initially surges the boom with a high water flow rate to reduce the probability of spray nozzles freezing closed, then establishes a water flow rate corresponding to the desired LWC based on a theoretical mass flow prediction and historical data adjusted for relative humidity (e.g., the flow rate will be higher than from mass flow calculation in air with low relative humidity). (Note: The test LWC and immersion time will determine how much water is to be carried for each mission).
- c. Concurrently, the JCH-47D crew set/verify the station-keeping radar altimeter indicators at the HISS operator's station are set at 150 ft. A repeater indicator is in the cockpit.

- d. Once the HISS flow stabilizes at the desired rate, the JUH-60M crew will visually verify the HISS spray cloud is uniform.
- e. The JCH-47D crew clears the JUH-60M to calibrate the HISS cloud after requesting and receiving confirmation that the required aircraft anti-ice and deice systems are on and operable.
- f. The JUH-60M pilot notifies the flight that he is repositioning for calibration run before repositioning below the HISS spray cloud and 150 to ft behind the JCH-47D in preparation to enter the spray cloud.
- g. The pilot enters into the HISS spray cloud from below and establishes a distance of approximately 150 ft behind the JCH-47D.
- h. Once positioned in the HISS spray cloud, the M300 operator starts cloud sampling.
- i. The M300 operator using the LWC data directs HISS operator to adjust the flow rate until achieving the desired cloud LWC state.
- j. Before departing the cloud, the team verifies the flow rate closely correlates with historical data for flow rate versus cloud LWC. (Note: The HISS spray MVDs are normally equal to or larger than natural icing MVDs for clouds with the same LWC that the HISS generates. Therefore, the icing severity in the HISS spray cloud will be greater than that experienced in natural icing).
- k. After calibrating the HISS cloud and verifying the cloud LWC meets the test matrix requirements, the JUH-60M pilot notifies the JCH-47D crew he is departing the cloud. The pilot then descends below the cloud and increases the clearance between the two aircraft before repositioning to the side opposite of the SUT and outside the effects of the JCH-47D rotor wash but close enough to observe the SUT once in position behind the HISS.

4.2.4 SUT Helicopter Icing Spray System Spray Cloud Operations.

- a. During HISS spray testing, the JCH-47D pilots will:
 - (1) Maintain the target airspeed ± 1 knots calibrated airspeed at all times.
 - (2) Vary altitude by slowly climbing/descending up to 100 ft/min to maintain static air temperature within $\pm 0.5^{\circ}\text{C}$ and/or to avoid clouds.
 - (3) Vary heading to maintain desired test track and/or to avoid clouds. Announce any heading changes in advance, the direction of the turn, and when executing the turn. Turns will be restricted to a shallow bank-angle of less than 10 deg.
 - (4) Attempt to select flight headings that keep the sun at approximate 45 to 90 deg off of the nose of the aircraft to optimize lighting for in-flight photo documentation of the ice accumulation on the SUT by the JUH-60M and/or JRC-12G photo chase (if used) and JCH-47D crews.

TOP 7-3-537
12 February 2009

(5) Manage the flight route in the test area to return the flight to within 5 nm of the departure airport at the anticipated completion of the test point immersion time.

b. Before entering the HISS spray cloud, SUT crew will fly a baseline maneuver group and record the data.

c. The JCH-47D crew will clear the SUT into the HISS spray cloud after verbally confirming (call and response) all anti-ice and deice systems are on and operable.

d. The SUT pilot notifies the flight that he is repositioning and repositions below the HISS spray cloud and 200 to 150 ft behind the JCH-47D in preparation to enter the spray cloud.

e. The pilot climbs into the HISS spray cloud from below and establishes a distance of approximately 150 ft behind the JCH-47D using the visual cues from the HISS station-keeping lights.

f. The SUT pilot will announce over the test frequency when the aircraft is established in the HISS spray cloud.

g. The test engineer will:

(1) Start recording immersion time with a stopwatch/clock, start time, TAT (°C), frost point (°C), pressure altitude (ft – altimeter set to 29.92), and airspeed (KIAS) (see sample data card in Figure 7).

(2) Repeat data recording at 5-min intervals and when the SUT exits the HISS spray cloud.

h. HISS crew will record HISS parameters and atmospheric data at 5-min intervals.

i. The JUH-60M crew and JCH-47D crewmember on the ramp will:

(1) Provide vertical and lateral position of the SUT in the cloud, respectively, to ensure proper immersion positioning for the fuselage or rotor system.

(2) Conduct photographic documentation of ice accretion as necessary.

Flight Number:
Date:
Flight Time:

Test Aircraft:
Flow Rate:

	Time of Day	Total Air Temp (°C)	Frost Point (°C)	Pressure Altitude (ft) set 29.92	Indicated Airspeed
Record Data at start of immersion, then every 10 –min and at clout exit					

Figure 7. Sample Data Card

j. The SUT crew will:

(1) If in a helicopter, establish initial target airspeed and fix the collective while maintaining altitude by varying airspeed to capture torque changes resulting from systems deice cycles. If in a fixed-wing aircraft, fly a constant airspeed by varying power to maintain airspeed and altitude.

(2) Record data manually at least every 5 min while installed data collection system records instrumentation continuously. Note all changes to power required, vibrations, and handling qualities.

(3) Provide periodic comments on the HISS spray cloud uniformity/quality, spray nozzle malfunctions/failures, turbulence, sun angle, and any other item worth noting during the flight.

k. The SUT immersion in the artificial cloud will be terminated at the end of the planned time or if one of the following conditions is met:

TOP 7-3-537
12 February 2009

- (1) Failure of SUT anti-ice or deice system(s) under evaluation.
- (2) Torque/power limit reached.
- (3) Unexpected change in aircraft performance or handling qualities.
- (4) Unexpected ice shedding that may or does result in damage to the aircraft.
- (5) Exceeding any other control limit established for the test flight.

l. At completion of the test time, the SUT pilot will announce intention to depart the HISS spray cloud. The pilots will then descend below the cloud and increase the distance behind the JCH-47, as required, before repositioning to the side of the JCH-47D opposite to the side the JUH-60M is on.

m. Once clear, the SUT pilot will repeat the profile/maneuver group for the test point.

n. Post-immersion in-flight photographic documentation of ice accretion by the JUH-60M/JRC-12G will be accomplished as necessary.

o. Determine the next test point or end of test and proceed accordingly (the SUT may need to completely deice before proceeding).

4.2.5 Post-test Actions.

a. If necessary, the JUH-60M will conduct a post-test cloud calibration using the same procedure less HISS spray adjustments described in paragraph 4.2.3.

b. After breaking formation, the SUT will depart directly back to airport for post-test ice measurements and documentation on the ground.

c. The HISS crew will terminate spray operations IAW the procedures in Technical Note, ATTC TN 90-01, Operation and Maintenance Procedures for CH-47 Helicopter Icing Spray System.

d. Once the SUT has landed and shutdown, the test team will measure and conduct photographic documentation of the ice accumulation on the aircraft (see sample data card in Figure 8).

ESSS ICING TEST FLIGHT SUMMARY

Flight No.	Date	Average Static Outside Air Temperature (°C)	Programmed Liquid Water Content (g/m ³)	Average Pressure Altitude (ft)	Average True Airspeed (kt)	Average Gross Weight (lb)	Average Center of Gravity (in)
Time in Cloud: (min)		Total this Flight _____ Cumulative Total _____		Type Ice Observed:			
Post-Flight Ice Measurements (inches)							
Component		Maximum Ice		Component		Maximum Ice	
Chin bubbles				Horizontal stores support			
Center windshield				Support struts			
Windshield wipers				Vertical stores pylons			
Aircraft nose				450-gal fuel tanks (inboard)			
Eyebrow windows				230-gal fuel tanks (outboard)			
Cockpit doors				Pitot-static tubes			
Sponsons				Engine compartment cooling intakes			
Cockpit door windows				Fixed provision attachment points			
Main landing gear				Horizontal stabilator			
Tail gear				Vertical fin			
Rotating beacons				Tail rotor hub			
Deice system OAT probe				Tail rotor blades			
Ship's system OAT probe				Deice system LWC probe			
Handholds				Hydraulic area fairing			
VHF-FM homing antenna							
Ice accretion probe							
Chaff dispenser							
Flare dispenser							
General Comments:							

Figure 8. Sample Flight Summary Data Sheet

4.3 Natural Icing.

Keep in mind that artificial icing (HISS) buildup procedures may be inappropriate for the natural icing testing. Typically, critical icing conditions in natural clouds (highest rates of ice accretions and subsequent performance penalties) will occur at warmer temperatures (-6 to -12°C) than those in the HISS spray cloud. At this temperature range, natural clouds tend to have their highest LWC values and produce ram's horn glaze icing accretions. Therefore, test day conditions must be thoroughly analyzed to ensure that appropriate buildup/test data exist for the particular test circumstances.

TOP 7-3-537
12 February 2009

4.3.1 Icing Conditions Survey.

a. When atmospheric conditions are conducive for natural icing, the JRC-12G crew will conduct an initial atmospheric icing survey. The JUH-60M may be used if the JRC-12G is unavailable but not recommended due to range and endurance limitations. The survey is conducted as follows:

(1) The JRC-12G takes off on an IFR clearance shortly after sunrise.

(2) Initially climb until reaching 10,000 ft or VMC to determine icing conditions, cloud layering, and top of cloud layer(s).

(3) Return to promising IMC conditions and conduct an icing survey and select a suitable test operations area based on coverage and intensity of icing conditions.

b. Icing data will be collected by ACME operator as follows:

(1) Power on and configure the ACME systems for natural icing per the checklist.

(2) Verify proper operation of the ACME-3 during climb out and note icing conditions in cloud layer(s) to assist in the icing survey.

(3) Once on top of the cloud layer(s) (VMC), calibrate or zero the CT LWC probe, as required.

(4) Before reentry into the cloud layer(s) (IMC), the pilots will clear any residual ice off the vernier accretion meter and OH-6 airfoil section probe.

(5) Upon cloud entry, start ACME-3 data recording and stopwatch.

(6) At 1- to 2-minute intervals, manually record time and the pilots' readings of their probes ice accumulation until ice buildup on the probes make accurate readings impossible (period based on ice accretion rate).

(7) Use the probe ice thickness data divided by the elapsed time in minutes to calculate a rate. Use this rate to enter Figure 9 (A&AEE Vernier Accretion Meter Liquid Water Content Calibration Chart) or Figure 10 (Small Airfoil Section Probe Liquid Water Content Calibration Chart), respectively, to determine the LWC. The data will be used to crosscheck and validate the other ACME icing probe readings.

(8) To help quantify the test conditions in the area where the SUT will loiter, periodically hand record GPS position and cross check with VOR radial and DME reading if available.

TOP 7-3-537
12 February 2009

(9) Manually record data using a data card such as that presented in Figure 4 to keep track of the recorded test blocks and other appropriate information to aid post flight data analysis.

A&AEE VERNIER ACCRETION METER
"HARVEY-SMITH"
LIQUID WATER CONTENT CALIBRATION CHART

- NOTES: 1. CALIBRATION BASED ON 100% CATCH
EFFICIENCY
2. FREEZING FRACTION OF UNITY

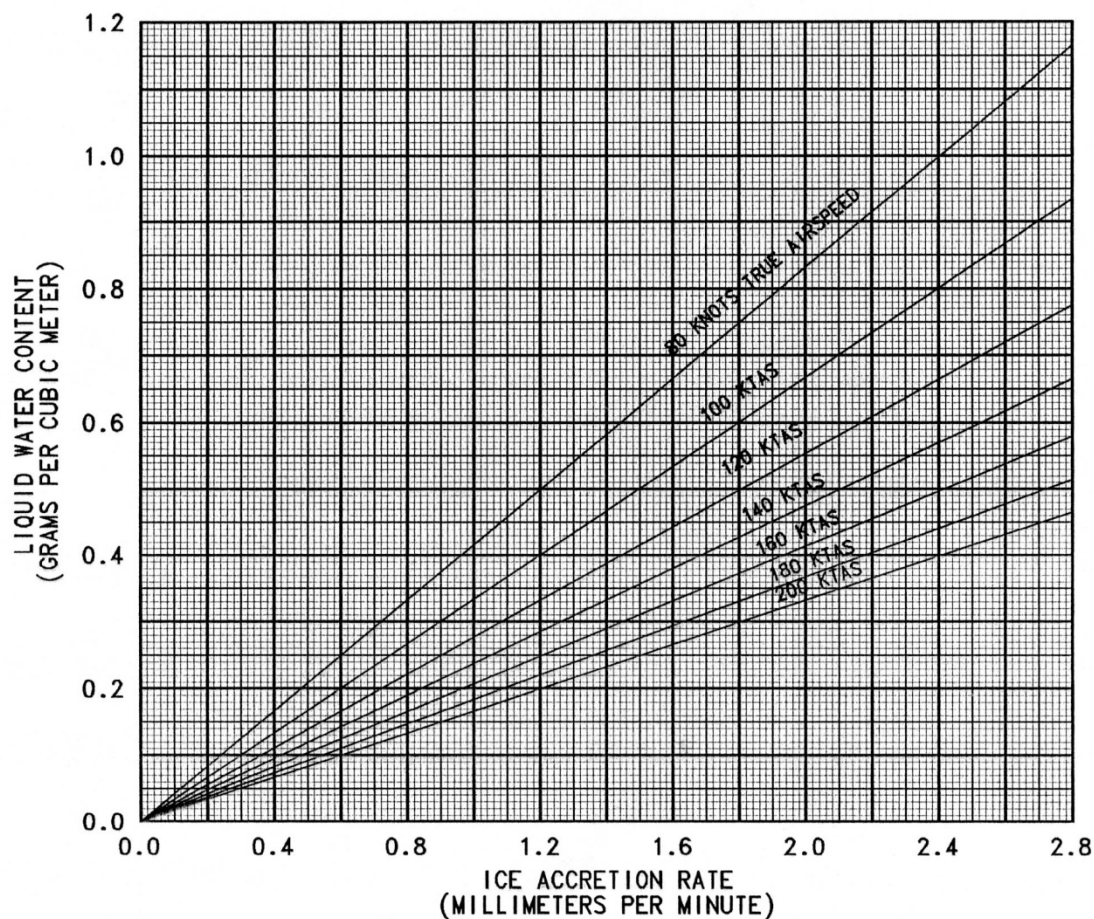

Figure 9. A&AEE Vernier Accretion Meter Liquid Water Content Calibration Chart

TOP 7-3-537
12 February 2009

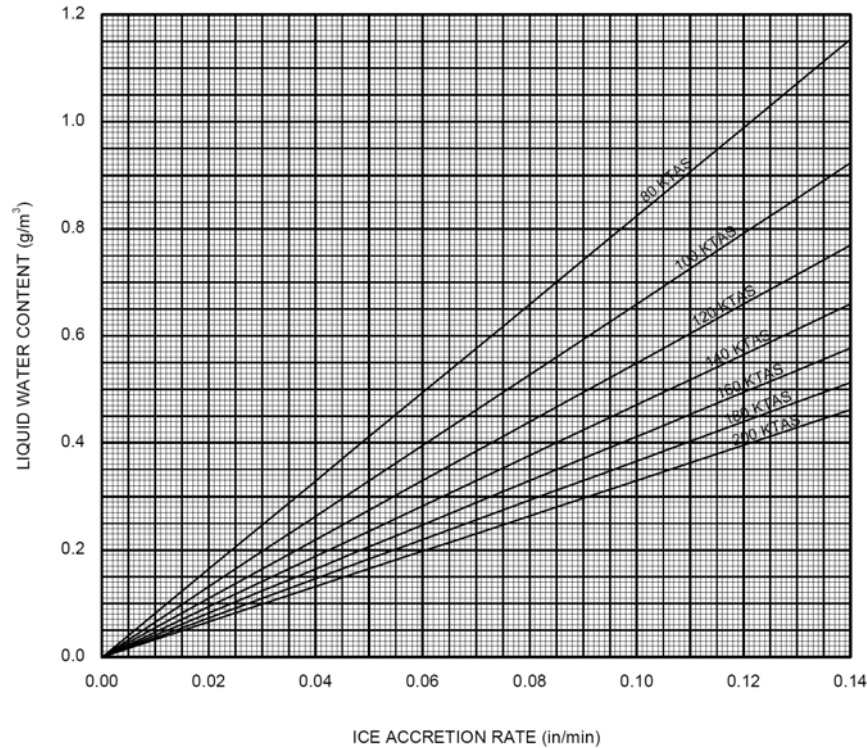

Figure 10. Small Airfoil Section Probe Liquid Water Content Calibration Chart

4.3.2 Natural Icing Testing.

- a. If suitable test day icing conditions exist, the SUT crew will depart on an IFR clearance to the block airspace identified by the JRC-12G crew.
- b. The JRC-12G will depart the test area block airspace and continue searching for better icing conditions.
- c. The pilots will establish the aircraft at the desired test conditions/configuration, clear of cloud if possible, and fly a maneuver group to establish a baseline for the flight.
- d. If feasible, the SUT will climb above the cloud layer(s) to VMC and descend into the selected icing conditions from above and remain within the upper 100 to 200 ft of the stratiform cloud layer to operate in the cloud's highest LWC regime. The pilot should fly at an altitude at which the sun appears to be an indistinct bright blob.
- e. Once the SUT enters the cloud/icing conditions, the crew will:
 - (1) If in a helicopter, establish initial target airspeed and fix the collective while maintaining altitude by varying airspeed to capture torque changes resulting from systems deice cycles.

(2) If in a fixed-wing aircraft, fly a constant airspeed by varying power to maintain desired airspeed and altitude.

(3) Record data manually at least every 5 minutes while onboard data acquisition systems record instrumentation continuously.

(4) Maintain the aircraft in the desired conditions and repeat the maneuver group regularly IAW the test plan. Note all changes to power required, vibrations, and handling qualities. If accompanied by a photo-chase aircraft, consider exiting the cloud periodically for photographs.

(5) The cloud characteristics must be recorded either by onboard instrumentation on the SUT or by a calibrated chase aircraft. Normally a calibrated aircraft will enter and sample the cloud every 15 minutes after ensuring positive separation from the SUT.

f. The SUT natural icing will be terminated at the end of the planned immersion time or if one of the following conditions is met:

(1) Failure of SUT anti-ice or deice system(s) under evaluation.

(2) Torque/power limit reached.

(3) Unexpected change in aircraft performance or handling qualities.

(4) Unexpected ice shedding that may or does result in damage to the aircraft.

(5) Exceeding any other control limit established for the test flight. (Note: This may require a climb or descent to VMC or temperatures above +2°C.)

g. Determine whether the results/data need to be examined before continuing to the next data point.

h. The SUT contacts the JRC-12G to arrange a join-up for the purposes of photo documentation.

i. The SUT initiates a climb to VMC while still remaining in the assigned block altitude.

j. The JRC-12G will maneuver as required in VMC to join the SUT.

k. After visually acquiring the SUT (use center or approach/departure control radar vectoring to approach the SUT) and before closing within 4-nm separation, the JRC-12G pilot advises the controlling agency that “Army (tail number of JRC-12G) is MARSAs with tail/N number/of the SUT.”

l. Once MARSAs, the aircraft joins a flight of two for photo documentation of ice accretions.

TOP 7-3-537
12 February 2009

m. At completion of photo documentation, the two aircraft separate and the JRC-12G pilot contacts the controlling agency and terminates MARSA.

n. If no other test point is planned, each aircraft will individually request IFR or VFR clearance back to the airfield for flight termination.

o. Once the SUT has landed and shutdown, the test team will measure and conduct photographic documentation of the ice accumulation on the aircraft.

5. DATA REQUIRED.

The test scope determines the data required. The data will vary between recorded instrumentation data, qualitative pilot comments, and visual/photo observation data. All data may be recorded by the SUT or a calibrated chase aircraft may record the cloud/atmospheric data and provide photographic documentation of the SUT. The test plan should contain a matrix of test points to cover sufficient areas of the SUT flight envelope to meet the test objectives.

5.1 Baseline Data Required.

The following data/information are(is) required before the start of testing:

- a. Aircraft basic weight.
- b. Aircraft basic cg position.
- c. Aircraft maneuver baseline data.

A maneuver group should be defined to provide baseline engine power required, vibration, and handling qualities data to enable comparisons to be drawn once the aircraft has accreted ice. The maneuver group could involve a level acceleration, a deceleration, specific angle-of-bank turns for a defined time, a climb at a specific rate, and a descent at a specific rate. The maneuver group is repeated every 10 to 15 minutes during ice accretion to determine the effects on aircraft power required, vibration, and handling. Regularly executing the maneuver group also ensures that flight controls are exercised frequently to prevent freezing. The use of a maneuver group for fixed-wing icing tests must be carefully considered due to the stall susceptibility and inaccurate stall warning when the aircraft is carrying ice.

- d. Engine(s) condition.

The engine(s) performance baseline must be known before test initiation for calibration/repeatability purposes and to enable foreign object damage (FOD) damage to be identified.

- e. Fuel system calibration.
- f. All previous icing test results for the aircraft to be tested.

- g. Results of any computer predictions of ice formations.
- h. Results of any dry air tests flown with artificial ice shapes fitted.
- i. Design and operating characteristics of any anti-ice/deice systems to be evaluated to include failure modes.
- j. Predicted stall speeds for various levels of ice accretion.
- k. Installed instrumentation calibrations.
- l. Aircraft pitot-static system calibrations and errors, TOP 7-3-057³.
- m. Physical characteristics.

5.2 Minimum Flight Test Data Required.

The following data/information are (is) required before the start of testing:

- a. Ambient air temperature, pressure altitude, cloud type (artificial/natural, stratus, stratocumulus, cumulus, cumulonimbus), LWC, and median volumetric diameter.
- b. True airspeed, observed airspeed, immersion time, fuel remaining, power required (torque rise), engine parameters, vibrFation assessment rating (VAR), vibration frequency (high, medium, low, 4R, 1R, etc.).
- c. Ice accretion characteristics: total ice accretion, rate of accretion, type of ice (rime, glaze, or mixed), appearance (feathery, ram's horn), and location.
- d. Ice shedding characteristics: amount shed and location.
- e. Qualitative handling comments.
- f. Photography as required/available.
- g. Anti-ice/deice system(s) effectiveness, screen heating, unusual noises, particular ice accretion locations, changes in vibration.

5.3 New Deice/Anti-ice System Performance Data.

The following data/information are(is) required before the start of testing:

- a. Time history of the following parameters:
 - (1) Temperature.

TOP 7-3-537
12 February 2009

- (2) Barometric pressure.
 - (3) Precipitation, rate, state, consistency, droplet size, liquid water content.
 - (4) Humidity.
 - (5) Altitude.
 - (6) Airspeed.
 - (7) Wind velocity relative to appropriate aircraft surface areas under consideration.
 - (8) Ice buildup rate and amount.
- b. Control settings, flight profile flown, and time required to clear ice buildup from each test run.
 - c. Ice shedding and trajectory characteristics and any damage; photograph and video as practical.
 - d. Relevant engine parameters (Ng, TGT, etc.) where the engine is a source of anti-ice/deicing energy.
 - e. Power timelines (volts, amps) to operate the anti-icing/deicing equipment for each run.
 - f. Incidence of unusual vibrations.
 - g. Amount of anti-ice/deicing fluid used.
 - h. Pulse rate and pressure of pneumatically operated deicing boots.

5.4 Further Data.

As indicated in Paragraph 2, further data recording is dependent on instrumentation based on the test objectives.

6. PRESENTATION OF DATA.

The results of an icing test are usually in the form of limitations, clearances, or compliance with specifications. Data presentation will depend on the results. Examples of likely data required are graphs of ice accretion amounts against time, ice accretion amounts against torque rise or vibration rise, ice accretion rate against airspeed, and structural dynamic data of ice accretion amount against vibration frequency change on critical components. A table of ice accretion amount on various components for each test condition as shown in Figure 11 is particularly useful. Photographic evidence as shown in Figure 12 to reinforce written comments are useful, as is video. Pilot comments on handling qualities can be plotted against ice accretion amounts.

Table XX. Post-Flight Residual Ice Accretion Measurements (Flight X)Average Liquid Water Content: xxg/m³
Average Static Air Temperature: -xx.x°C

Aircraft Component	Residual Ice Accretion
Sponsons	1" Pilot
Ship's System OAT Probe	1-1/2" Pilot
VHF-FM Homing Antenna	1-1/2" Pilot
Cockpit Step	1-1/2" Pilot
HF Com Antenna – Tail Boom	1-1/2"

Figure 11. Sample Ice Accretion Table

**Figure XX. Ice Accretion on Tail Rotor Hub**Flight xx: Configuration – Utility Environment – Natural Time in Cloud: xx min
Avg Static Air Temperature: -xx.x°C Avg Liquid Water Content: XXX g/m³

Figure 12. Sample Icing Photo documentation

APPENDIX A. ICING INSTRUMENTATION

1.1 Ice Detectors.

The Cloud Technology (CT) ice detector (formerly known as Johnson-Williams) has a calibrated resistance wire mounted in the airstream and is connected as one branch of a balanced bridge circuit. Electric current heats this wire. As the water droplets in the cloud strike the wire, they evaporate, thereby cooling the wire and decreasing its resistance. The change in resistance causes the bridge to become unbalanced. The degree of unbalance is a function of the LWC of the cloud. A second resistance wire, mounted with its axis parallel to the airstream direction and hence not subject to water droplet impingement, is connected as an adjacent branch of the bridge. This wire serves to compensate for variations in airspeed, altitude, and air temperature, so that the bridge becomes unbalanced only in the presence of water droplets. The output of the bridge is proportional to the rate of impingement of water on the sensing wire. This signal is converted to concentration of water per unit volume of air by means of an adjustment for true airspeed. The Rosemount ice detector has a sensing element (probe) which is a sealed tube protruding from the ice detector strut and exposed to the airstream environment. The probe vibrates ultrasonically in the axial direction at its natural mechanical resonant frequency of about 40 kHz. This axial vibration is caused by an oscillator driving a coil in the probe to create a magnetostrictive force. A sensing coil within the probe senses the motion and in turn supplies the oscillator input. The change in probe length is on the order of a few millionths of an inch and is not discernible visually. When ice accumulates on the probe, the mass of the vibrating material is thereby increased which decreases the resonant frequency of the probe in accordance with classical mechanics. The frequency decrease is proportional to mass (correlated to thickness) of ice adhering to the probe. This change in frequency is sensed and processed by the electronics in the meter subassembly to provide a warning signal and trigger the probe deicing cycle. The frequency of the warning/deice cycle is dependent on the rate of icing and thus provides an indication of icing severity. Both types of ice detectors (aspirated and nonaspirated) operate in the same manner but the sensitivity with airspeed variation is different.

Particle Measurement Probes

Particle Metrics, Inc., (PMI) manufactures typical particle measurement probes. Two well-known probe types are the forward-scattering spectrometer probe (FSSP) (Figure A-1) and the optical array (cloud droplet (or precipitation) spectrometer) probe (OAP). Each PMS probe projects a collimated helium-neon laser beam normal to the airflow across a small sample area. In forward flight, particles passing through the beam (sample area) are counted and measured into 15 size channels per probe, each probe operating over a different size range. While these probes are primarily intended as particle sizing devices, a LWC can be calculated from the droplet size measurement and number count within the sample volume relative to airspeed.

Droplet Measurement Technologies (DMT) has taken over PMI and is developing the next generation of aircraft rated instruments for collecting droplet size and density.

TOP 7-3-537

12 February 2009

1.2.1 The PMI FSSP-100 determines particle size by measuring the amount of light scattered into the collecting beam optics aperture as the particles pass through the laser beam. A pulse height analyzer compares the maximum amplitude of the scattering signal pulses with a reference voltage derived from a separate measurement of the illuminating light signal. The pulse height analyzer output is encoded to give the particle size in binary code and resolves particle sizes from 3 to 45 microns (10^{-6} m) into 15 equally spaced increments 3 microns wide. It is capable of sizing particles having velocities of 20 to 125 m/sec (39 to 243 kt). A gate output signal provides a measure of particle transit time, and a velocity averaging counter and control system determines an average transit time. The system automatically rejects particles with transit times less than average since these are susceptible to edge effect errors and result from particles passing through regions of less than maximum intensity.

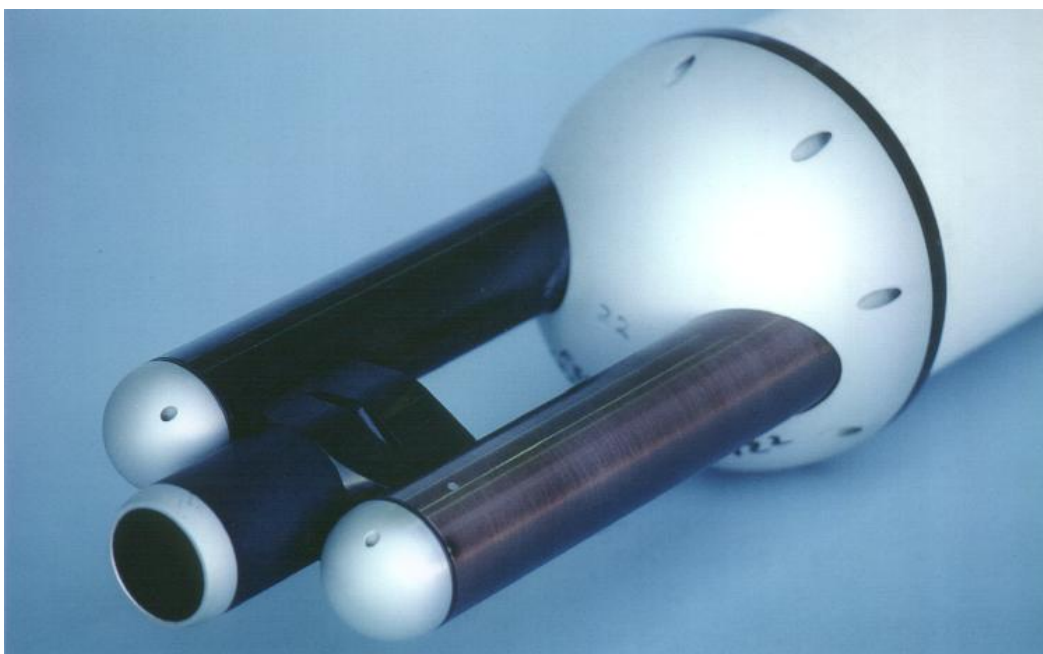
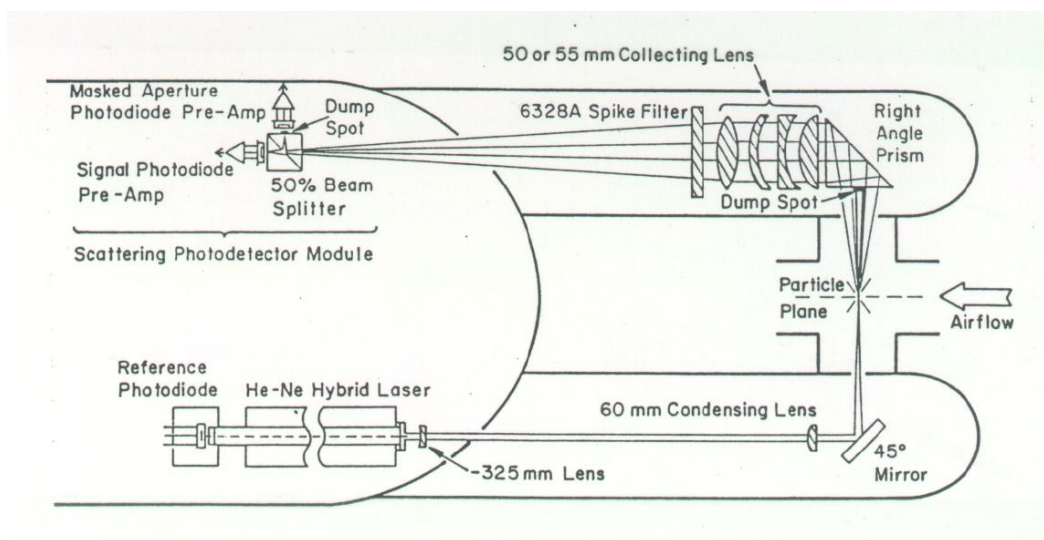

Figure A-1. FSSP-100 Probe

The FSSP-100-ER operates in the same manner as the FSSP-100 but has an extended particle sizing range. The size range is set at the ACME station from 3 to 45 microns (range 1) or 6 to 95 microns (range 0) depending upon usage. The extended range allows the engineer to better determine if super-cooled large droplets are present.

1.2.2 The PMI OAP-200X (Figure A-2) determines particle size using a linear array of photo-diodes to sense the shadowing of array elements. Particles passing through the field-of-view illuminated by its laser are imaged as shadowgraphs on the array and a flip-flop memory element is set if the photo-diode elements are darkened. Size is given by the number of elements set by a particle's passage, the size of each array element, and the optical magnification. Magnification is set for a size range of 20 to 300 microns and 24 active photo-diode elements divide particles into 15 size channels (bins), each 20 microns wide. It is capable of sizing particles with velocities between 5 and 100 m/sec (10 to 194 kt). When used in combination with the FSSP-100 (artificial icing only), the first two bins of the OAP-200X overlap the size range of the FSSP-100. Therefore, these two bins are ignored in the combined calculation of MVD.

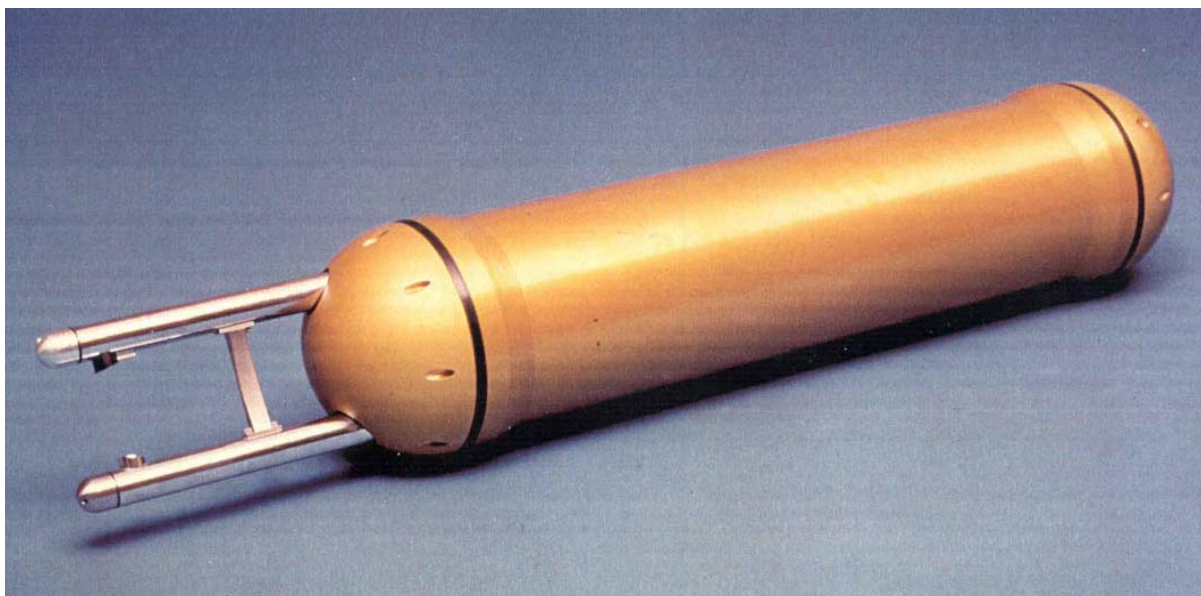

Figure A-2. OAP-200X

The OAP-200Y is the same design as the OAP-200X but with detection magnification set for 300 to 4500 microns for large water (rain) and ice crystals. The OAP-200Y is used for measuring water content in rain.

The OAP-2DGA2 determines particle size using a linear array of photo-diodes to sense the shadowing of array elements. Particles passing through the field-of-view illuminated by its laser are imaged as shadowgraphs onto the photo-diode array. Three levels of darkness are sensed, providing three levels of grey information on the particle from each of the 64 elements of the array. Size is given by the number of elements set by a particle's passage, the size of each array element, and the optical magnification. Magnification is set for a size range of 10 to 620 microns and 64 active photo-diode elements divide particles into 62 size channels (bins), each 10 microns wide. The OAP-2DGA2 is capable of sizing particles with velocities between 10 and

TOP 7-3-537
12 February 2009

100 m/sec (19 to 194 kt). When used in combination with the FSSP-100-ER, the first nine bins of the OAP-2DGA2 overlap the size range of the FSSP-100-ER. Therefore, these nine bins are ignored in the combined calculation of MVD.

1.2.3 The DMT cloud, aerosol, and precipitation spectrometer (CAPS) probe (Figure 3 A-3) is a single integrated measurement system that provides aerosol particle and cloud hydrometeor size distributions from 0.5 to 50 μm , particle shape (discrimination between water and ice), particle optical properties (refractive index), precipitation size distributions from 25 μm to 1550 μm , liquid water content from 0.01 to 3 gm^{-3} and aircraft velocity and atmospheric temperature and pressure. CAPS replaces PMS Inc., FSSP-100, FSSP-300, 2D-C, 2D-P, and KLWC. The CAPS has two optical sensors to derive the size of individual particles: (1) the cloud imaging probe (CIP) is an optical spectrometer that measures the size and shape of particles passing through its collimated laser beam, from 25 μm to 1550 μm , liquid water content from 0.01 to 3 gm^{-3} and airspeed to 200 ms. The CIP uses a fast 64-element photodiode array to generate 2-dimensional images of the particles, as well as sizing in 1-dimensional histogram form; (2) the cloud aerosol spectrometer (CAS) collects the light scattered in the forward direction (4-12 $^\circ$) by particles passing through a focused laser beam and converts the light intensity to a particle diameter between 0.5 and 50 μm using Mie light scattering theory. The CAS also measures backscattered light (168-176 $^\circ$) to derive particle refractive index and shape factors. Three pieces of information are recorded by the CAS about each particle: the forward scattered light intensity, backward scattered light intensity, and the time between each particle. The particle by particle information is used to derive size distributions, particle refractive index and shapes, and concentration fluctuations at scales of a meter or less.

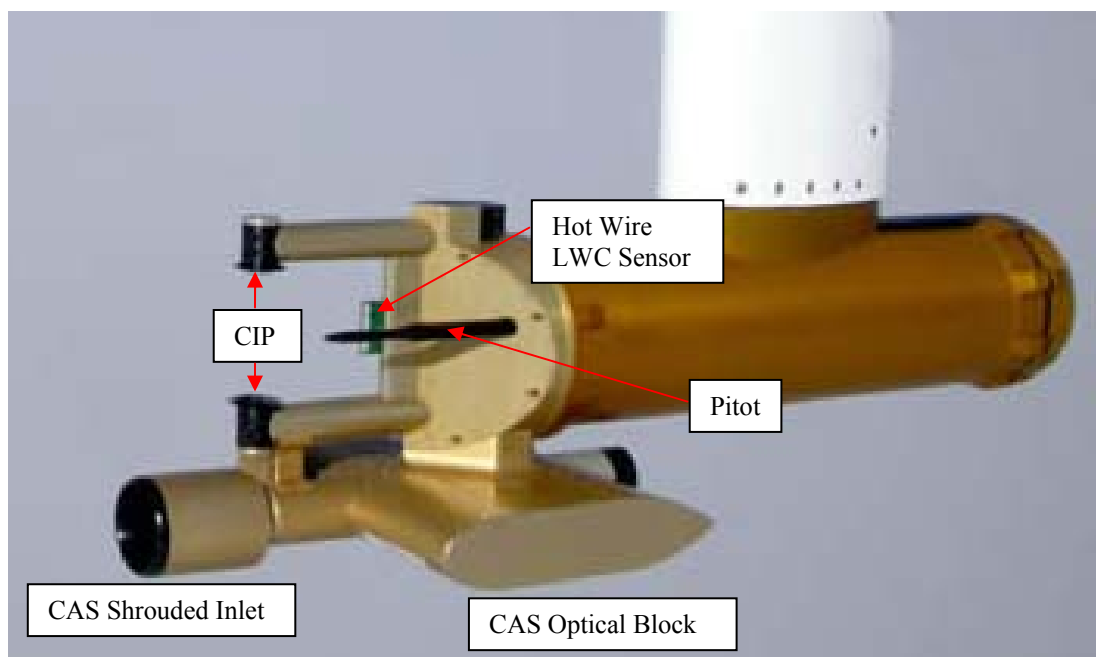

Figure A-3. Cloud, Aerosol, and Precipitation Spectrometer Probe

1.2.4 The DMT cloud combination probe (CCP) (Figure A-4) is five instruments packaged into a single, integrated measurement system that provides aerosol particle and cloud hydrometeor size distributions from 0.5 to 50 μm , precipitation size distributions from 25 μm to 1550 μm , liquid water content from 0.05 to 3 gm^{-3} , and aircraft velocity, atmospheric temperature and pressure. This instrument replaces PMS Inc.'s FSSP-100, FSSP-300, 2D-C, 2D-P and KLWC. The CIP is the same as in the CAPS probe. In place of the CAS probe the CCP uses DMT's cloud droplet probe (CDP) a miniature, light weight, low-power cloud particle spectrometer that measures droplets in the range of 3-50 μm in concentrations as high as 2000 cm^{-3}

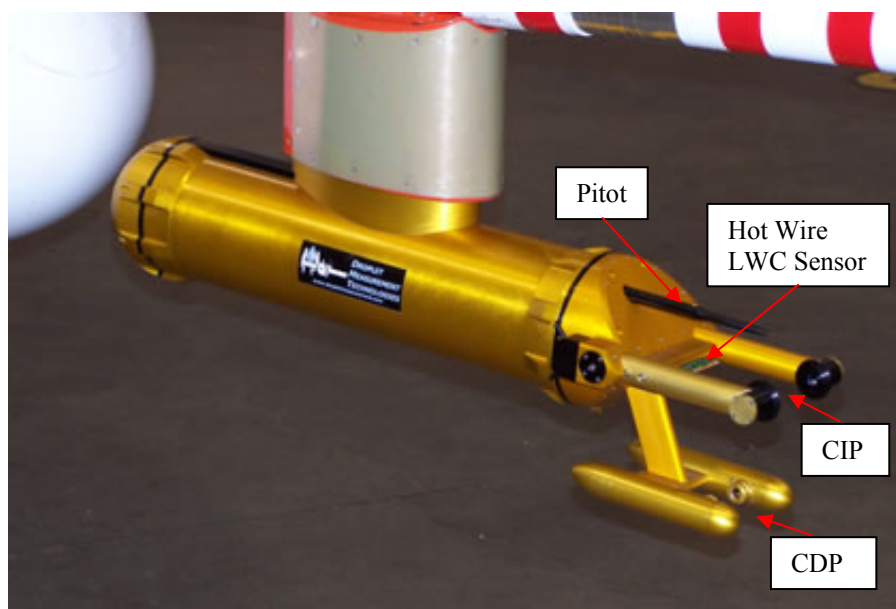

Figure A-4. Cloud Combination Probe

1.2.5 The cloud technology ice detector (formerly known as and still sometimes called a Johnson-Williams) (Figure A-5) has a calibrated resistance wire mounted in the airstream and connected as one branch of a balanced bridge circuit. Electric current heats this wire. As the water droplets in the cloud strike the wire, they evaporate, cooling the wire and decreasing its resistance. The change in resistance causes the bridge to become unbalanced. The degree of unbalance is a function of the LWC of the cloud. A second resistance wire, mounted with its axis parallel to the airstream direction and hence not subject to water drop impingement, is connected as an adjacent branch of the bridge. This wire serves to compensate for variations in airspeed, altitude, and air temperature, so that the bridge becomes unbalanced only in the presence of water droplets. The output of the bridge is proportional to the rate of impingement of water on the sensing wire. This signal is converted to concentration of water per unit volume of air by means of an adjustment for true airspeed.

TOP 7-3-537
12 February 2009

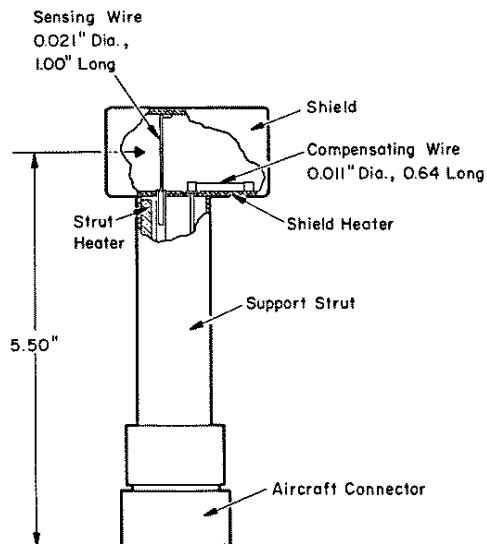

Figure A-5. Cloud Technology Ice Detector

1.3 Visual Accretion Devices

Two visual accretion devices The Aeroplane & Armament Experimental Establishment (A&AEE) (now Defence Evaluation and Research Agency) vernier accretion meter (sometimes referred to as a “Harvey Smith” (Figure A-6)) and a small airfoil section (SAS) probe (an OH-6 tail rotor section attached to a metal framework) are used to substantiate the LWC measurements obtained from other devices. The A&AEE and SAS devices are externally mounted near the pilot and copilot windows, respectively. Readings of ice accretion on both probes are taken at timed intervals to determine accretion rate.

Readings of ice accretion on both probes are taken at timed intervals at constant true airspeed to determine accretion rate. By visually aligning the datum lines on the A&AEE probe, the apex of the “V” is at zero on the calibrated scale (Figure A-6). The pilot reads the ice depth on the scale at the point where the accreted ice on one leg of the “V” crosses the vernier scale on the other leg. A calibration chart (Figure A-8) is used to determine the LWC from indicated icing rate (millimeters per minute) and airspeed. The small airfoil section probe has a protruding 3/16-in. diameter steel rod painted with multi-colored 1/4-in. stripes to provide a reference for ice thickness estimation. Figure A-7 is used to determine LWC for this probe's indicated icing rate (in/min).

Figure A-8 is derived from the following equation:

$$I = \frac{0.1882V_T(LWC)}{0.6}$$

where:

I = potential ice accretion (cm)

V_T = true airspeed (kt)

t = elapsed time in the cloud (hr)

0.1852 = conversion factor $\left(\frac{\text{m}^3}{\text{mm} \cdot \text{cm}^3}\right)$

LWC = liquid water content (g/m³)

0.8 = assumed density of ice (g/cm³)

Figure A-9 comes from the same equation by applying a conversion factor of 2.54 cm/in. The above equation assumes a collection efficiency of 100%. Collection efficiency, a combination of catch efficiency and freezing fraction, is the ratio of the mass of liquid water that strikes the surface and freezes to the total mass of liquid water contained in the free stream. From tunnel tests conducted by A&AEE, collection efficiencies approaching 90% are possible for LWC of:

up to 1.0 g/m³ at -20°C

up to 0.8 g/m³ at -10°C

up to 0.5 g/m³ at -6°C

up to 0.2 g/m³ at -3.5°C

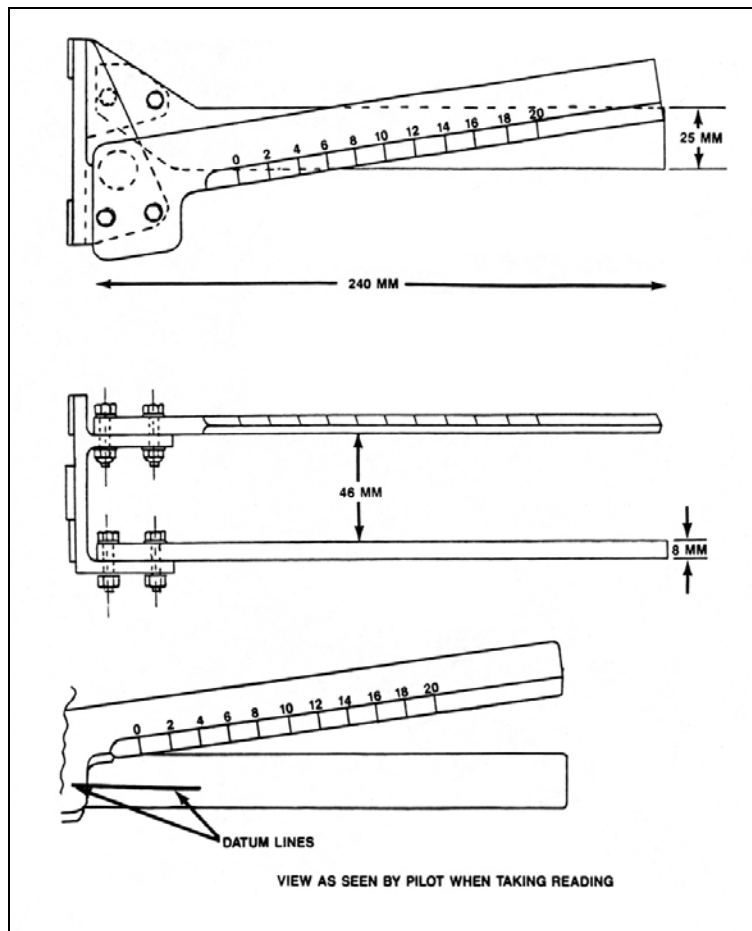

Figure A-6. Vernier Accretion Meter (“Harvey Smith”)

TOP 7-3-537
12 February 2009

LWC DETERMINATION

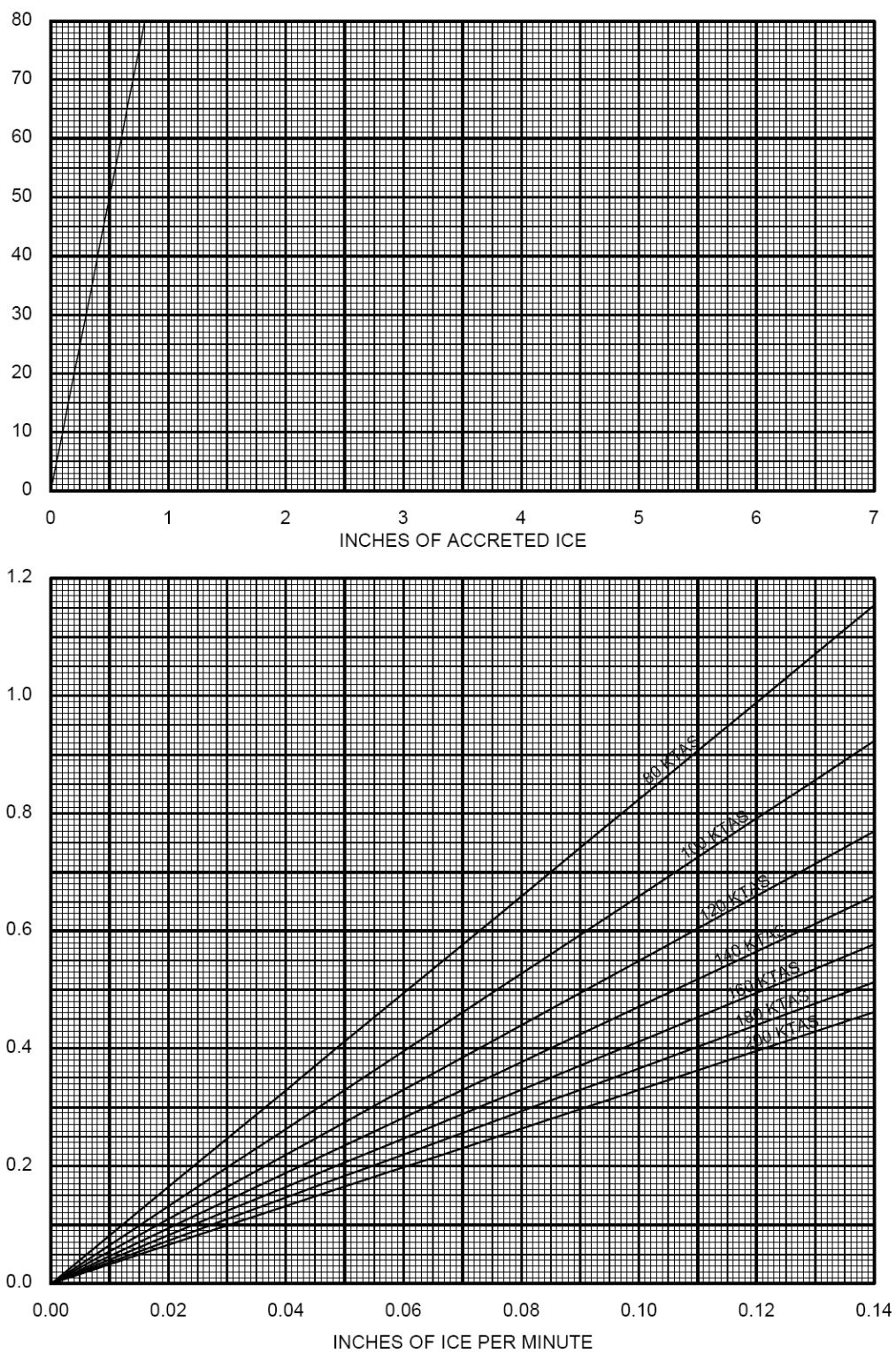

Figure A-7 LWC Determination

A&AEE VERNIER ACCRETION METER
"HARVEY-SMITH"
LIQUID WATER CONTENT CALIBRATION CHART

- NOTES: 1. CALIBRATION BASED ON 100% CATCH
EFFICIENCY
2. FREEZING FRACTION OF UNITY

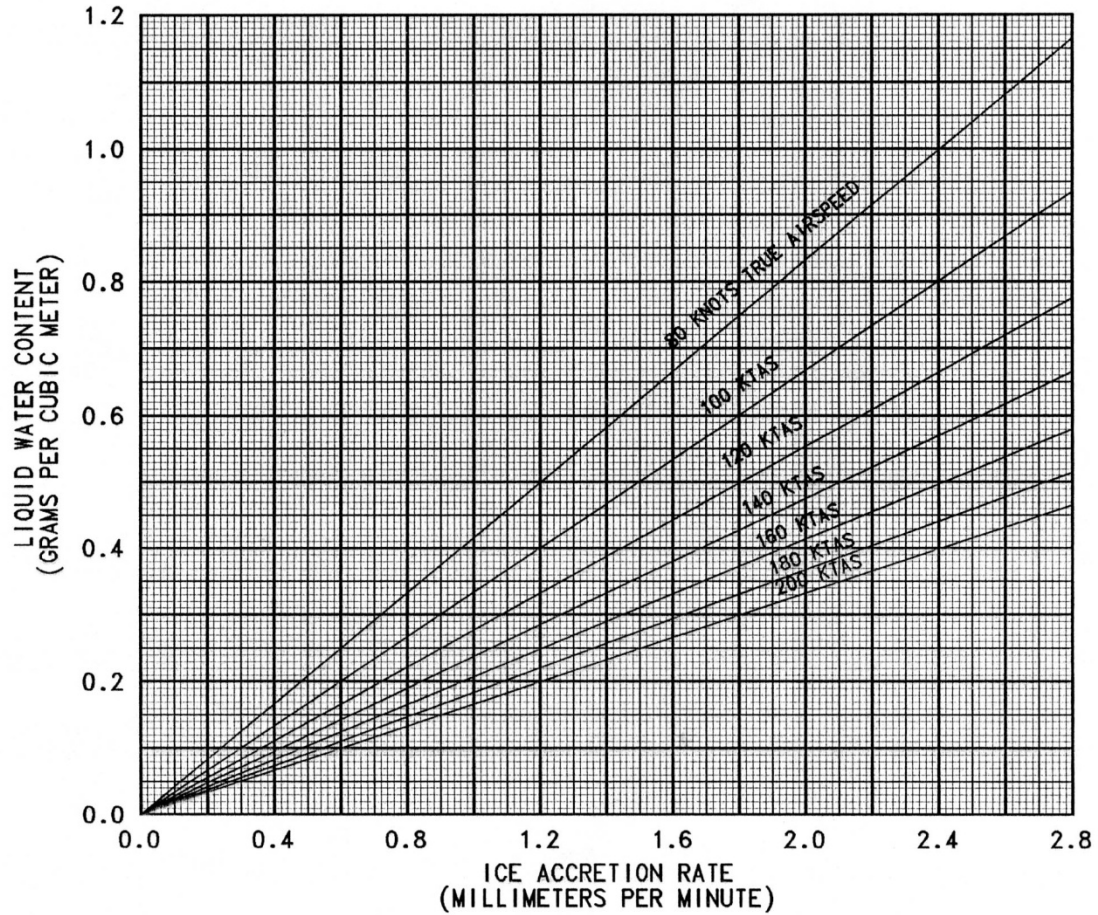

Figure A-8. A&AEE Vernier Accretion Meter Liquid Water Content Calibration Chart

TOP 7-3-537
12 February 2009

SMALL AIRFOIL SECTION PROBE ("OH-6" AIRFOIL)
LIQUID WATER CONTENT CALIBRATION CHART

- NOTES: 1. CALIBRATION BASED ON 100% CATCH EFFICIENCY
2. FREEZING FRACTION OF UNITY

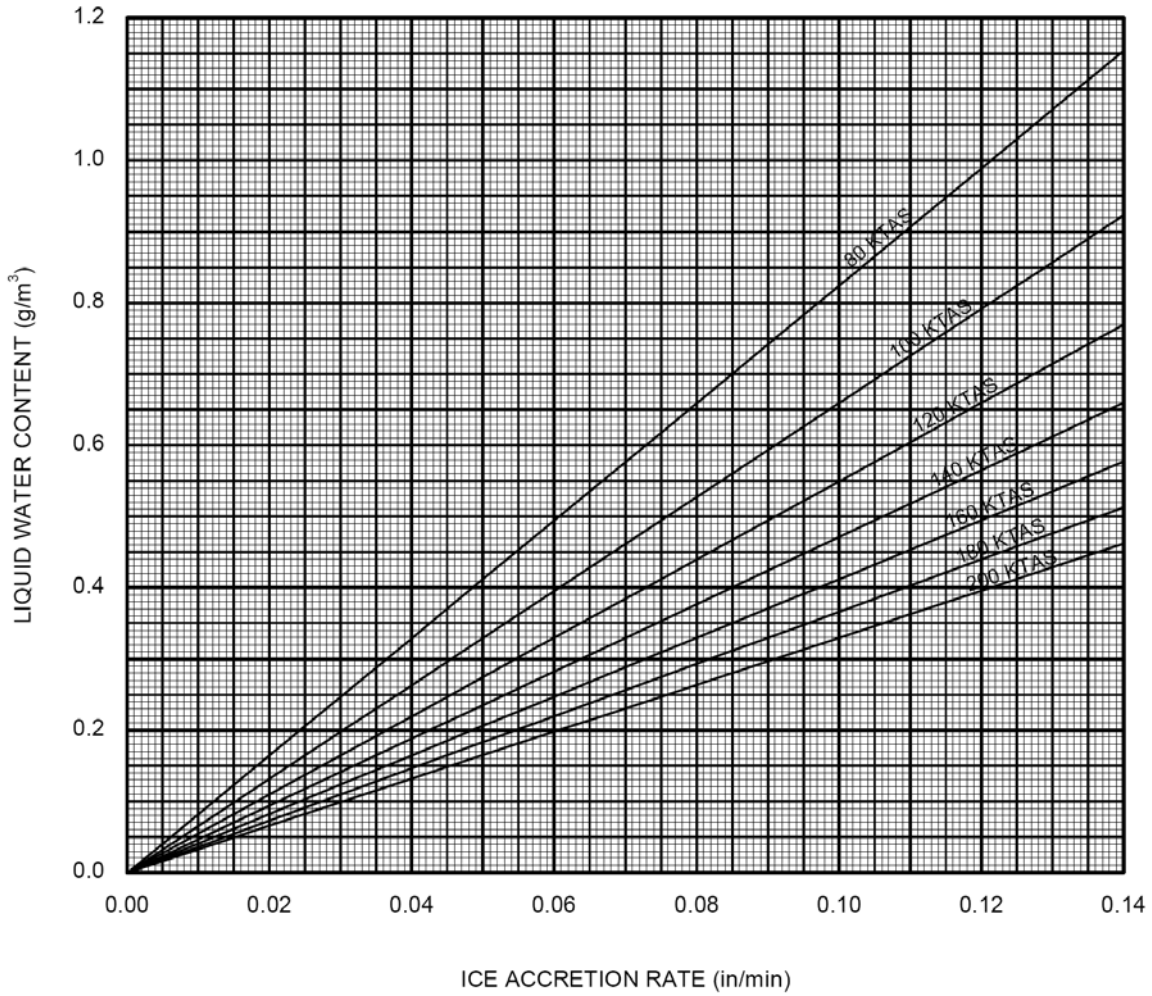

Figure A-9. Small Airfoil Section Probe Liquid Water Content Calibration Chart

APPENDIX B. ICING TEST HAZARD ANALYSIS¹

Hazard	Causes	Mitigations	Mitigation Type	Mitigation Category	Corrective Actions
1. Ice contamination on main and/or tail rotor blades leading to a critical loss of power margin or control margin, and severe vibration.	1. Unplanned full or partial failure of anti/de-ice system(s) while in icing conditions	1. Ensure crew familiar with anti/de-ice system(s) failure indications. 2. Ensure crew familiar with alternative modes of anti/de-ice system(s) operation. 3. Ensure crew familiar with possible areas of ice accretion on rotorcraft. 4. Ensure crew familiar with vibration characteristics of rotorcraft with and without ice accretion and familiar with change in vibration when anti/de-ice system(s) is functioning during heat-on cycle. 5. Monitor independently torque and anti/de-ice system(s) parameters during flight test.	1. T 2. T 3. T 4. T 5. P	1. P 2. P 3. P 4. P 5. P	1. Exit icing conditions as soon as possible (maneuver out of spray to end icing exposure) 2. Adjust airspeed to best rate of climb airspeed (VBROC) to reduce retreating blade stall effects and increase power margin. 3. Ensure ice protection systems are ON. 4. Consider descent to lower altitude to increase power margin, reduce aircraft loads, and go to higher temperatures.
	2. Encountering icing conditions outside design conditions for the ice protection system(s). (Note that the tanker flight plan may include data points beyond the design points of the test aircraft to determine system limitations.)	1. Ensure crew familiar with possible areas of ice accretion on rotorcraft and unusual artificial icing conditions (e.g., supercooled large drops). 2. Monitor size of ice accretion of items in pilot's view. 3. Ensure crew familiar with vibration characteristics of rotorcraft with and without ice accretion and familiar with change in vibration when anti/de-ice system(s) is functioning during heat-on cycle. 4. Monitor independently torque and anti/de-ice system(s) parameters during flight test.	1. T 2. P 3. T 4. P	1. P 2. P 3. P 4. P	1. Exit icing conditions as soon as possible (maneuver out of spray to end icing exposure) 2. Adjust airspeed to best rate of climb airspeed (VBROC) to reduce retreating blade stall effects and increase power margin. 3. Ensure ice protection systems are ON. 4. Consider descent to lower altitude to increase power margin, reduce aircraft loads, and go to higher temperatures.

Note: Mitigation Type: D - Design; S - Safety Device/Feature; T - Training; P - Procedure; A - Analysis, G - Ground Tests; W - Warning/Placard; R - Pre-requisite Flight Test
 Mitigation Category: P - Reduces Probability of Occurrence; S - Reduces Severity of Consequence

¹ Test Hazard Analysis created by the Icing Data Development Committee for NASA's Flight Test Safety Database

TOP 7-3-537
12 February 2009

Hazard	Causes	Mitigations	Mitigation Type	Mitigation Category	Corrective Actions
2. Excessive stress on flight critical components due to increased vibratory loads.	1. Asymmetrical ice condition.	<ol style="list-style-type: none"> 1. Use safety chase and/or video (as applicable) to inspect helicopter during test. 2. Monitor helicopter vibration. 3. Pre-select emergency fields near test location. 4. Conduct ground icing tests prior to icing flight tests. 	<ol style="list-style-type: none"> 1. S 2. P 	<ol style="list-style-type: none"> 1. P 2. P 	<ol style="list-style-type: none"> 1. Exit icing conditions as soon as possible (maneuver out of spray to end icing exposure) 2. Adjust airspeed to best rate of climb airspeed (VBROC) to reduce retreating blade stall effects and increase power margin. 3. Ensure ice protection systems are ON. 4. Consider descent to lower altitude to increase power margin, reduce aircraft loads, and go to higher temperatures. 5. Perform frequency sweep to shed ice (pilot must be experienced in conducting test and familiar with the limitations). 6. Land as soon as practicable, depending on the severity of the vibrations.
	2. Shed ice impacting with rotating or fixed components.	<ol style="list-style-type: none"> 1. Ensure crew familiar with vibration of aircraft with and without ice accretion and familiar with change in vibration when anti/de-ice system(s) is functioning during heat-on cycle. 2. Monitor torque and anti/de-ice system(s) parameters during flight test. 3. Conduct ground icing tests prior to icing flight tests. 	<ol style="list-style-type: none"> 1. T 2. P 	<ol style="list-style-type: none"> 1. P 2. P 	<ol style="list-style-type: none"> 1. Exit icing conditions as soon as possible (maneuver out of spray to end icing exposure) 2. Adjust airspeed to best rate of climb airspeed (VBROC) to reduce retreating blade stall effects and increase power margin. 3. Ensure ice protection systems are ON. 4. Consider descent to lower altitude to increase power margin, reduce aircraft loads, and go to higher temperatures. 5. Land as soon as possible. 6. Investigate and understand cause. 7. Obtain flight clearance before continuing test.

Note: Mitigation Type: D - Design; S - Safety Device/Feature; T - Training; P - Procedure; A - Analysis, G - Ground Tests; W - Warning/Placard; R - Pre-requisite Flight Test
Mitigation Category: P - Reduces Probability of Occurrence; S - Reduces Severity of Consequence

Hazard	Causes	Mitigations	Mitigation Type	Mitigation Category	Corrective Actions
3. Damage to Engine.	1. Shed Ice into Engine Inlets from Rotating or Nonrotating Components.	1. Engine ignition on prior to artificial cloud entry. 2. Monitor size of ice accretion of items in pilot's view. 3. Use safety chase and/or video (as applicable) to inspect helicopter during test. 4. Monitor critical engine and anti/de-ice system(s) parameters. 5. Conduct engine wind tunnel/chamber tests prior to flight tests.	1. P 2. P 3. P 4. P	1. S 2. P 3. P 4. P	1. Exit icing conditions as soon as possible (maneuver out of spray to end icing exposure and to allow sublimation of ice, with possible descent to lower altitude to reduce aircraft loads). After leaving cloud, can also adjust airspeed to best rate of climb airspeed (VBROC) to reduce retreating blade stall effects and to reduce aircraft loads. 2. Land as soon as possible. 3. Investigate and understand cause. 4. Correct cause before continuing test.
	2. Inoperative Engine Anti-ice System.	1. Engine anti-ice ground preflight check. 2. Engine anti-ice enabled as test setup. 3. Monitor critical engine parameters. 4. Conduct engine wind tunnel / chamber tests prior to flight tests.	1. G 2. P 3. P	1. P 2. P 3. P	1. Exit icing conditions as soon as possible (maneuver out of spray to end icing exposure) 2. Adjust airspeed to best rate of climb airspeed (VBROC) to reduce retreating blade stall effects and increase power margin. 3. Ensure ice protection systems are ON. 4. Consider descent to lower altitude to increase power margin, reduce aircraft loads, and go to higher temperatures. 5. Land as soon as possible. 6. Investigate and understand cause. 7. Correct cause before continuing test.

Note: Mitigation Type: D - Design; S - Safety Device/Feature; T - Training; P - Procedure; A - Analysis, G - Ground Tests; W - Warning/Placard; R - Pre-requisite Flight Test
Mitigation Category: P - Reduces Probability of Occurrence; S - Reduces Severity of Consequence

TOP 7-3-537
12 February 2009

Hazard	Causes	Mitigations	Mitigation Type	Mitigation Category	Corrective Actions
3. Damage to Engine.	3. Compressor surge/stall due to high distortion of airflow into engine inlet from ice accretion.	1. Ensure engine/inlet anti-ice system(s) ON prior to cloud entry. 2. Engine ignition on prior to cloud entry. 3. Instrument flow in front of intake. 4. Monitor critical engine parameters. 5. Conduct engine wind tunnel/chamber tests prior to flight tests.	1. P 2. P 3. P 4. P	1. S 2. S 3. P 4. P	1. Exit icing conditions as soon as possible (maneuver out of spray to end icing exposure and to allow sublimation of ice, with possible descent to lower altitude to reduce aircraft loads). After leaving cloud, can also adjust airspeed to best rate of climb airspeed (VBROC) to reduce retreating blade stall effects and to reduce aircraft loads. 2. Land as soon as possible. 3. Investigate and understand cause. 4. Correct cause before continuing test.
4. Ice Impact Damage to Rotating Components.	1. Shed ice from rotating or nonrotating components.	1. Ensure proper operation of ice protection systems. 2. Ensure engine/inlet anti-ice system(s) ON prior to cloud entry. 3. Ensure crew familiar with vibration of aircraft with and without ice accretion and familiar with change in vibration when anti/de-ice system(s) is functioning during heat-on cycle. 4. Monitor torque and anti/de-ice system(s) parameters during flight test. 5. Monitor size of ice accretion of items in pilot's view. 6. Use safety chase and/or video (as applicable) to inspect helicopter during test. 7. Employ gradual buildup with ice shape, size, and location. 8. Conduct engine wind tunnel/chamber tests prior to flight tests.	1. G 2. P 3. T 4. P 5. P 6. S 7. P	1. P 2. P 3. P 4. P 5. P 6. P 7. P	1. Exit icing conditions as soon as possible (maneuver out of spray to end icing exposure) 2. Adjust airspeed to best rate of climb airspeed (VBROC) to reduce retreating blade stall effects and increase power margin. 3. Ensure ice protection systems are ON . 4. Consider descent to lower altitude to increase power margin, reduce aircraft loads, and go to higher temperatures. 5. Land as soon as possible. 6. Investigate and understand cause. 7. Correct cause before continuing test or obtain flight clearance before continuing test.

Note: Mitigation Type: D - Design; S - Safety Device/Feature; T - Training; P - Procedure; A - Analysis, G - Ground Tests; W - Warning/Placard; R - Pre-requisite Flight Test
Mitigation Category: P - Reduces Probability of Occurrence; S - Reduces Severity of Consequence

TOP 7-3-537
12 February 2009

Hazard	Causes	Mitigations	Mitigation Type	Mitigation Category	Corrective Actions
5. Ice Impact Damage to Nonrotating Components.	1. Shed ice from rotating or nonrotating components.	1. Ensure proper operation of ice protection systems. 2. Ensure crew familiar with vibration of aircraft with and without ice accretion and familiar with change in vibration when anti/de-ice system(s) is functioning during heat-on cycle. 3. Monitor torque and anti/de-ice system(s) parameters during flight test. 4. Monitor size of ice accretion of items in pilot's view. 5. Use safety chase and/or video (as applicable) to inspect helicopter during test.	1. G 2. T 3. P 4. P 5. S	1. P 2. P 3. P 4. P 5. P	1. Exit icing conditions as soon as possible (maneuver out of spray to end icing exposure) 2. Adjust airspeed to best rate of climb airspeed (VBROC) to reduce retreating blade stall effects and increase power margin. 3. Ensure ice protection systems are ON. 4. Consider descent to lower altitude to increase power margin, reduce aircraft loads, and go to higher temperatures. 5. Analyze situation and determine best course of action.
6. Main rotor blade impact with ground and/or helicopter during engine shutdown.	1. Inoperative droop stop heaters	1. Conduct grey-beard review and analysis of droop stop design ice protection system. 2. Evaluation of droop stop ice protection system in climatic hangar artificial icing tests. 3. Evaluation of droop stop ice protection system in tanker artificial icing tests.	1. A/D 2. G 3. R	1. P 2. P 3. P	1. Monitor droop stops while rotors turning at reduced rpm before engine shutdown. 2. Use rotor brake to control final stopping of the rotor.
7. Inability to maintain flight condition.	1. Loss of engine power during flight in icing conditions.	1. Establish minimum en route altitudes. 2. Consider implications of loss of engine and associated subsystems on aircraft recovery. 3. Monitor and maintain power margins. 4. Monitor critical engine parameters.	1. P 2. A 3. P 4. P	1. S 2. P 3. P 4. P	1. Exit icing conditions as soon as possible (maneuver out of spray to end icing exposure) 2. Adjust airspeed to best rate of climb airspeed (VBROC) to reduce retreating blade stall effects and increase power margin. 3. Ensure ice protection systems are ON. 4. Consider descent to lower altitude to increase power margin, reduce aircraft loads, and go to higher temperatures. 5. Maintain altitude at or above minimum en route altitude. 6. Test within glide range emergency airfields.

Note: Mitigation Type: D - Design; S - Safety Device/Feature; T - Training; P - Procedure; A - Analysis, G - Ground Tests; W - Warning/Placard; R - Pre-requisite Flight Test
Mitigation Category: P - Reduces Probability of Occurrence; S - Reduces Severity of Consequence

TOP 7-3-537
12 February 2009

Hazard	Causes	Mitigations	Mitigation Type	Mitigation Category	Corrective Actions
7. Inability to maintain flight condition.	2. Vibration levels due to ice accretion too high for continued safe flight testing.	1. Ensure proper operation of ice protection systems. 2. Monitor vibration levels during icing encounters. 3. Conduct vehicle wind tunnel/chamber tests prior to flight tests.	1. G 2. P	1. P 2. P	1. Exit icing conditions as soon as possible (maneuver out of spray to end icing exposure and to allow sublimation of ice, with possible descent to lower altitude to reduce aircraft loads). After leaving cloud, can also adjust airspeed to best rate of climb airspeed (VBROC) to reduce retreating blade stall effects and to reduce aircraft loads. 2. Adjust airspeed to minimize vibration levels. 3. Maintain altitude at or above minimum en route altitude. 4. Analyze situation and determine best course of action.
	3. Loss of lift due to ice accretion.	1. Ensure proper operation of ice protection systems. 2. Monitor critical parameters for indications of severe icing conditions.	1. A 2. G 3. P	1. P 2. P 3. P	1. Exit icing conditions as soon as possible (maneuver out of spray to end icing exposure) 2. Adjust airspeed to best rate of climb airspeed (VBROC) to reduce retreating blade stall effects and increase power margin. 3. Ensure ice protection systems are ON. 4. Consider descent to lower altitude to increase power margin, reduce aircraft loads, and go to higher temperatures. 5. Attempt to maintain altitude at or above minimum en route altitude. 6. Attempt to maintain controlled flight. 7. Seek assistance from chase aircraft, if available. 8. Analyze situation and determine best course of action (e.g., wait for conditions to improve (due to temperature), bailout, autorotation

Note: Mitigation Type: D - Design; S - Safety Device/Feature; T - Training; P - Procedure; A - Analysis, G - Ground Tests; W - Warning/Placard; R - Pre-requisite Flight Test
Mitigation Category: P - Reduces Probability of Occurrence; S - Reduces Severity of Consequence

APPENDIX C. ICING TEST SITE SELECTION

1. INTRODUCTION

Unlike large fixed-wing aircraft, helicopters have limited range, endurance, climb capabilities, and service ceilings. This is true for most of today's helicopters and those speculated for development in the next few years. These limitations pose/demand a different set of ground rules for the conduct of natural icing flight tests, either for research or certification purposes.

Large fixed-wing aircraft typically can be subjected to a large variety of natural icing test conditions during one winter test season. This is possible because the test aircraft can be based, in some instances, at the manufacturer's own plant where all necessary support is available, and fly to prevailing weather conditions, conduct necessary testing, and return. This is customarily done in one day's operation, and sometimes may entail flights of several thousand miles in one day. Aircraft of this type also have the ability to take advantage of icing conditions that may exist in the upper extremities of cumulus-type clouds that often contain high liquid water contents (LWC) and the lower extremes of ambient temperatures.

The helicopter, as well as small fixed-wing aircraft, has a very different problem. Test helicopters, because of limited range, endurance, airspeed, and service ceiling, must be prepositioned at test sites in geographical regions where icing conditions are prevalent. Most commonly, the test site selected is many miles away from the manufacturer or test agency's facility. This dislocation is costly in many respects, so the site selection must thoroughly consider many variables to assure that maximum benefit is obtained from the investment.

The Rotorcraft Icing Working Group of the Advisory Group for Aerospace Research and Development (AGARD) flight mechanics panel (FMP) has taken advantage of past experience of the North Atlantic Treaty Organization (NATO) member nations to develop a list of site selection parameters that are important to consider during the planning phase of a natural icing test program. This list, along with characteristics of test sites used by various member nations, is contained in Table C-1. The following paragraphs discuss the various site selection parameters. ATTC's Technical Note, Icing Testing contains additional details for Duluth Minnesota Operations.

2. SITE SELECTION PARAMETERS.2.1 Atmosphere.

The atmospheric conditions that prevail at or near the site selected must be determined to be prevalent during the planned test period. The classical icing test for certification purposes dictates that a large percentage of the weather conditions will consist of cloud types and ambient temperatures that produce supercooled cloud icing conditions. The frequent existence of these conditions is paramount for natural icing tests.

TOP 7-3-537
12 February 2009

In addition, however, specific testing in snow conditions is sometimes required to verify tolerance of certain components to the snow environment. It is also speculated that, in the future, freezing rain and drizzle conditions will be required to allow testing to be performed to at least determine remedial actions, if not to establish operational/flight limitations of the helicopter in these conditions. Only limited flight testing has been conducted to date in freezing rain or drizzle conditions.

Use of long-term statistical data is considered the only accurate method of determining the probable frequency of occurrence of various weather conditions. However, caution is advised. Statistical (long-term) data will not assure that average conditions will prevail during any one test season. Conditions may be atypical of the monthly averages. If at all possible, alternate natural icing test sites should be selected and decision points made to move the test operation from the primary site to allow flexibility needed to assure a successful test season. On-site test managers must have the authority and the resources to make this decision to allow maximum utilization of prevailing weather conditions.

In the United States, the National Weather Service (NWS) and the U.S. Air Force (USAF) Environmental Technical Applications Center are repositories for long-term statistical data on which to base natural icing test site selections.

Requests for specific information must be submitted far enough in advance to allow these agencies time to compile the necessary information. Data requests are usually required to be submitted in writing; however, face-to-face, or at least telephone, discussions with the agencies' personnel is highly encouraged to assure a thorough dialogue and understanding of the specific questions being asked and the data being provided in response to those questions.

Key parameters to be considered are listed in column 1 of table 1. These parameters are self-descriptive for the most part. Cloud ceiling, however, is a parameter that has been overlooked in the past (Table C-2). Specific attention to early establishment of cloud ceiling and visibility requirements that are stipulated for flight safety, cloud egress, and rescue purposes is encouraged. These limits must be established before submitting a request for data.

2.2 Airspace.

The natural icing test site selected must have several features that are compatible with the communications and navigation capabilities of the test aircraft.

Weather systems in many instances are scattered or very localized. The test team cannot rely upon one established small boundary in a local test area, but must seek authority to conduct natural icing testing anywhere within the safe operational range of the aircraft to enhance the probability of a successful test season. Prior authority must be negotiated and obtained from the local air traffic control (ATC) authorities. Again, face-to-face discussions with the affected ATC officials, airport managers, tower operators, other organized local operators, and in some localities, civic leaders are required.

2.3 Navigation Aids.

The following navigational aids must be compatible with the test aircraft.

Ground Radar. Two considerations are important: availability of ground radar for traffic avoidance and vector information to supplement other navigation aids, and use in emergencies to vector a rescue aircraft to the site of a downed aircraft. Radar deflection and usable altitude limitations in proposed test areas become important considerations.

Communications. It is essential that radio communications exist, not only with ATC but with the aviation weather service in addition to normal communications between the test aircraft, chase or crash/rescue aircraft, and the base of test operations. It is also highly desirable to have telephone communications with each of the service (ATC, weather, tower) agencies.

Traffic Density. Icing tests must be conducted under adverse weather conditions. If a busy airport is selected as the base of operations, test capability can be extremely limited by ATC because of other traffic either in departure, approach, or in achieving clearances for flight at various test altitudes within the control zone. The ability of the test crew to climb or descend in the event of a problem is also encumbered. It becomes highly desirable to select a test area where the traffic density is as small as possible.

Population Density. Remote areas are always desirable for any test purpose; however, not always possible. Several key problems must be considered during the site selection process. The possibility of an in-flight accident is paramount during icing tests. However, during icing tests, particles of ice can be shed from the test aircraft and could be hazardous in populated areas, either to personnel or structures. Special attention must be given to these considerations in final approach and test recovery areas.

Emergency Landing Sites. Availability of emergency landing sites should exist in flight test areas. In addition, topography must not inhibit search and rescue operations.

2.4 Aircraft Support and Test Support

Support of the test aircraft becomes essential during the conduct of helicopter natural icing tests. The test helicopter should normally be equipped with instrumentation for flight test data acquisition. Hangar, laboratory, and office facilities must be available not only for aircraft shelter, but also to support normal aircraft maintenance and inspection; instrumentation maintenance, checkout, and calibration; and data processing, data reduction, and analysis. Data processing may require availability of local, commercial computer facilities that must be compatible with test aircraft instrumentation tapes and recordings. To assure this compatibility, extensive coordination may be required during the test planning phase.

Most test helicopters will be equipped with ice detection and ice protection systems that are in the experimental, developmental, prototype stages of development. Aircraft support facilities should accommodate the needs for inspection, maintenance, checkout, calibration, troubleshooting, and repair of these systems. Engineering and maintenance capability/expertise must also be available to perform these functions. Of particular importance is the availability of

TOP 7-3-537
12 February 2009

ground power units of the proper size and compatibility with the test aircraft that are approved for hangar operation for use in ground checkout and troubleshooting of electrothermal-type ice protection systems.

In some tests, requirements exist for dedicated crash/rescue or chase aircraft. Aircraft shelter, logistical support, and maintenance support of these aircraft become essential considerations. In most regions that natural icing test sites would be considered, surface temperatures are usually very cold. If the hangar is heated, as it should be for adequate test support, many hangar custodians have rigid hangar door-opening schedules for energy conservation or may impose door opening fees to offset the heating costs. This becomes an important consideration during the site selection process. Heated hangar space is essential when an artificial icing tanker is required for test purposes.

2.5 Domestic Considerations

The test crews assigned the responsibility for conduct of helicopter natural icing tests are usually dedicated for an entire test season that may last 2 to 5 months and, most commonly, are far away from home. The natural icing test site selection process must consider the human element and ensure that adequate accommodations for lodging, dining, and transportation are available, commensurate with test duration

The results of the test are dependent upon the attitude of the test team, and that attitude most certainly is dependent upon the morale of the individuals. One basic assumption must be made in the site selection process: if the test is worth doing, the human needs of the test team must be considered.

3. SUMMARY

Table C-3 summarizes the considerations for icing test sites and the impact each may have on program schedule, cost, and safety.

TOP 7-3-537
12 February 2009

Table C-1

DULUTH INT'L., MINNESOTA

STA NO. 72745 (IN AREA NUMBER 12)	LATITUDE 4650N												LONGITUDE 0921W												ELEVATION
PARAMETER DESCRIPTION	JAN	FEB	MAR	APR	MAY	JUN	JUL	AUG	SEP	OCT	NOV	DEC	ANN												
ABS MAX TMP (F)	52	53	78	88	87	93	97	97	90	85	68	50	41												
MEAN MAX TMP (F)	19	23	32	48	60	69	76	74	64	54	35	23	48												
MEAN MIN TMP (F)	1	4	14	30	39	48	55	55	45	36	21	7	30												
ABS MIN TMP (F)	-35	-28	-26	-5	20	30	37	37	22	9	-17	-33	-35												
MEAN NO DYS TMP = DR GTR 90(F)	0.0	0.0	0.0	0.0	0.0	0.5	0.4	0.8	0.1	0.0	0.0	0.0	1.8												
MEAN NO DYS TMP = DR LES 32(F)	31.0	27.7	30.5	21.6	7.2	0.1	0.0	0.0	2.7	12.1	27.0	30.9	190.8												
MEAN NO DYS TMP = DR LES 0(F)	17.3	11.3	5.6	0.2	0.0	0.0	0.0	0.0	0.0	0.0	2.3	10.7	47.4												
MEAN DEW PT TMP (F)	1	7	14	26	30	49	56	55	46	36	21	7	20												
MEAN REL HUM (PCT)	73	74	73	67	66	71	74	77	78	75	77	77	74												
MEAN PRESS ALT (FT)	1262	1260	1327	1396	1395	1414	1392	1375	1342	1321	1317	1284	1337												
MEAN PRECIP (IN)	1.01	0.83	1.63	2.35	3.40	4.53	5.91	4.08	3.05	2.08	1.77	1.14	29.8												
MEAN SNOW FALL (IN)	13.6	10.6	13.4	6.1	0.8	0.0	0.0	0.0	0.0	1.1	4.3	12.3	66.2												
MEAN NO DYS PRCP = DR GTR 0.1 IN	2.4	2.4	4.2	5.5	6.4	7.3	6.7	6.9	5.1	3.8	3.3	3.0	57.2												
MEAN NO DYS SNFL = DR GTR 1.5 IN	3.6	3.1	3.3	2.0	0.6	0.0	0.0	0.0	0.0	0.2	1.7	2.9	17.4												
MEAN NO DYS W/DCUR VSBY LES 1/2 MI	4.1	2.9	3.7	3.6	5.0	6.1	5.5	6.0	4.7	4.7	3.2	3.9	53.4												
MEAN NO DYS TSTMS	0.0	0.0	0.0	1.0	4.0	6.0	7.0	6.0	4.0	1.0	0.0	0.0	29.0												
P FREQ WND SPD = DR GTR 17 KTS	14.9	16.1	18.4	25.6	19.6	10.5	6.6	5.4	11.5	14.4	20.2	13.1	14.7												
P FREQ WND SPD = DR GTR 28 KTS	1.2	1.8	1.7	3.1	3.4	0.4	0.1	0.2	0.2	0.4	1.5	0.8	1.1												
P FREQ LES 3000 FT A/D LES 3 MI	38.0	37.4	34.4	35.3	30.3	24.9	21.8	26.0	35.2	36.9	49.1	45.3	34.6												
P FREQ LES 1500 FT A/D LES 3 MI																									
FOR 00-02 LST	26.4	24.5	21.6	17.9	19.2	15.6	14.1	16.8	20.3	20.6	30.2	33.0	21.7												
03-05 LST	26.2	28.0	26.5	22.1	23.9	19.7	16.6	22.2	24.3	22.8	30.4	33.3	24.7												
06-08 LST	29.9	31.0	30.1	24.9	24.7	20.4	17.3	23.7	30.6	27.2	31.9	34.4	27.2												
09-11 LST	28.0	28.5	22.8	19.8	19.8	15.8	14.3	19.5	23.6	25.2	30.1	34.3	23.5												
12-14 LST	23.7	21.0	15.0	15.0	14.3	10.1	8.4	12.5	16.5	19.9	27.7	29.5	17.8												
15-17 LST	22.8	17.9	14.2	14.0	13.7	6.9	6.2	10.5	12.5	16.3	25.4	26.0	19.5												
18-20 LST	19.6	18.1	16.6	15.6	15.3	7.7	7.3	13.0	14.3	17.7	25.0	26.7	16.4												
21-23 LST	22.1	20.7	18.2	17.0	17.6	10.8	9.9	14.1	17.0	20.2	29.4	29.1	18.8												
P FREQ LES 300 FT A/D LES 1 MI																									
FOR 00-02 LST	4.8	6.5	6.3	4.4	9.4	8.9	7.5	8.8	7.6	8.2	7.0	6.2	7.3												
03-05 LST	6.8	5.9	8.3	7.8	10.7	10.3	9.6	12.9	8.7	8.3	7.7	8.6	8.8												
06-08 LST	9.5	7.6	8.3	9.0	9.1	8.8	8.2	10.9	9.5	9.3	8.7	7.8	6.9												
09-11 LST	6.9	6.0	5.6	6.2	6.5	5.0	3.9	5.3	4.4	6.5	7.0	6.8	5.8												
12-14 LST	4.7	3.8	4.5	4.6	4.2	3.1	1.1	3.8	2.6	3.9	5.6	5.7	4.0												
15-17 LST	4.1	4.0	3.9	3.9	3.4	2.3	0.7	3.4	3.1	3.6	5.1	6.5	3.7												
18-20 LST	3.9	4.8	5.0	4.7	4.9	3.2	3.0	4.9	3.7	7.3	6.3	6.2	4.8												
21-23 LST	3.9	5.0	4.9	4.7	8.2	5.9	4.8	6.2	6.9	7.0	5.4	6.9	5.8												

TOP 7-3-537
12 February 2009

Table C-2

DULUTH INT'L., MINNESOTA

MEAN NUMBER OF DAYS

PARAMETER DESCRIPTION	JAN	FEB	MAR	APR	MAY	JUN	JUL	AUG	SEP	OCT	NOV	DEC	ANN	POB	NO.
CIG = GTR 1000 FT AND VSBY = GTR 3 MI	1R LST 26.5	24.1	26.9	26.6	27.3	26.1	24.9	27.7	26.8	26.6	24.8	25.3	219.6	12	4383
	00 LST 25.1	23.4	25.7	23.6	26.1	26.0	27.7	27.0	24.8	23.7	23.9	23.5	204.7	12	4383
	06 LST 24.0	21.8	23.3	23.7	24.4	24.6	26.1	23.9	22.2	24.8	23.8	23.3	205.9	12	4383
	12 LST 24.2	23.0	27.5	26.2	27.2	27.4	29.0	27.7	26.1	26.2	22.7	24.1	212.3	12	4383
CIG = GTR 2000 FT AND VSBY = GTR 3 MI	1R LST 12.3	10.9	11.1	7.2	8.6	12.2	14.9	17.1	15.8	13.5	10.7	9.2	243.5	12	4383
	00 LST 10.1	9.7	12.6	12.4	14.2	17.1	18.8	19.0	13.9	12.4	9.4	9.7	158.3	12	4383
	06 LST 10.1	9.2	11.9	10.7	10.5	12.6	16.7	17.1	12.2	11.7	8.3	8.9	139.9	12	4383
	12 LST 7.8	6.4	8.9	5.4	5.5	6.8	8.6	8.4	6.2	6.4	5.3	7.2	80.9	12	4383
SFC WND = GTR 17 KTS AND NO PRECIP.	1R LST 3.8	2.8	4.1	6.4	6.1	3.0	1.9	1.0	2.0	3.3	4.6	3.7	42.7	12	4012
	00 LST 3.7	3.1	4.6	4.2	2.7	1.3	0.7	0.6	2.0	2.2	3.0	3.5	32.2	12	3916
	06 LST 4.8	3.4	3.7	3.4	4.1	2.0	0.7	1.0	2.1	2.1	4.3	3.2	36.8	12	3910
	12 LST 5.3	3.1	6.6	3.3	6.3	6.5	4.7	3.0	7.2	7.7	7.6	5.1	79.2	12	3984
SFC WND 4-10 KTS AND TMP 33-89 DEG F AND NO PRECIP.	1R LST 0.1	1.2	4.6	9.4	11.7	13.2	17.0	20.1	17.8	15.1	6.7	0.8	117.7	12	4012
	00 LST 0.2	0.3	1.2	9.0	16.4	19.9	21.1	20.8	17.7	14.3	3.4	0.3	123.0	12	3914
	06 LST 0.0	0.3	0.7	5.5	12.9	16.3	19.3	19.7	14.7	10.8	2.5	0.6	103.3	12	3910
	12 LST 0.3	0.8	2.7	7.2	8.1	10.3	13.1	13.4	10.9	9.1	4.6	1.2	82.7	12	3984
SKY COVER LFS 3/10 AND VSBY = GTR 3 MI	1R LST 10.1	10.1	8.7	6.2	7.2	7.1	11.3	9.6	8.0	10.7	7.5	6.5	106.0	12	4383
	00 LST 10.2	11.1	12.5	11.1	13.7	12.1	15.0	15.7	12.0	12.6	8.4	9.0	144.2	12	4383
	06 LST 11.1	10.9	10.0	6.2	6.8	9.0	11.4	10.1	7.9	10.7	7.1	9.6	114.8	12	4383
	12 LST 8.8	9.3	9.1	6.8	8.1	6.7	5.1	6.3	6.4	8.7	5.6	6.5	84.6	12	4383
CIG = GTR 2500 FT AND VSBY = GTR 3 MI	1R LST 22.6	20.7	24.6	24.2	23.6	27.0	28.2	26.6	25.0	24.0	20.3	19.9	288.7	12	4383
	00 LST 21.0	19.6	23.7	23.5	23.9	24.6	26.4	25.8	23.2	23.8	18.1	18.1	272.5	12	4383
	06 LST 21.1	18.3	20.1	20.6	21.6	22.7	25.2	22.7	20.0	20.9	17.6	18.5	149.3	12	4383
	12 LST 21.8	18.9	23.1	22.3	24.3	24.9	26.7	24.4	21.8	22.7	17.9	18.9	207.7	12	4383
CIG = GTR 4000 FT AND VSBY = GTR 3 MI	1R LST 20.2	18.6	21.4	19.1	22.3	24.0	25.8	25.0	19.7	19.9	16.4	17.8	249.9	12	4383
	00 LST 18.7	17.5	20.5	19.6	21.8	22.7	24.2	24.3	19.9	20.5	14.8	16.2	240.7	12	4383
	06 LST 18.7	16.4	17.4	17.2	19.9	20.8	22.7	21.5	14.3	18.2	14.3	15.7	221.3	12	4383
	12 LST 19.7	17.2	19.9	17.8	19.9	19.7	20.8	20.2	16.8	12.5	14.6	16.7	221.8	12	4383
CIG = GTR 10000 FT AND VSBY = GTR 3 MI	1R LST 16.2	17.3	19.4	17.3	18.3	20.6	23.8	23.0	17.9	18.7	14.0	16.2	227.7	12	4383
	00 LST 17.9	16.1	19.4	17.1	18.8	20.3	22.1	22.8	17.7	18.7	13.9	14.6	218.6	12	4383
	06 LST 16.6	15.1	16.1	15.2	17.8	18.9	20.8	19.7	15.9	16.6	12.4	14.4	179.7	12	4383
	12 LST 17.8	16.1	18.2	16.4	17.8	18.2	19.4	18.9	15.2	17.6	12.9	15.0	203.3	12	4383

Table C-3
LIST OF CONSIDERATIONS FOR SELECTING ICING TEST SITES

Key

- A Required to conduct icing flight test
- B Lack of will result in significant program delays
- C Lack of may result in program delays or increased cost

WEATHER

- A Mix of VMC and IMC conditions (natural and artificial at one location)
- B More VMC in Jan and Feb
- B Increasing IMC in Feb and Mar (natural ice not snow)
- B Reasonable ceilings and visibilities (not extremely low)
- A Upper air temperatures of 0 to -20C between 1500 ft AGL and 10,000 ft MSL
- B High relative humidity

FACILITIES

- B Low airfield elevation (provides maximum flexibility for altitude and temperature selection; HISS limited to 10,000 ft MSL)
- B+ Flat terrain (no mountains, not over oceans or large lakes)
- B Sparse population
- B Low air traffic
- B Convenient and flexible ATC capability (IFR for natural icing tests)
- B Satisfactory approach facilities
- A Heated hangar (100 x 70 ft with 20-ft door for HISS)
- A Heated hangar (test aircraft)
- B Heated hangar (support aircraft)
- B Office space for 35-50 people
- A Telephone
- C Telephone (DSN)
- A Telephone (commercial)
- B Snow removal (runways, ramps, hanger door threshold)
- B Satisfactory ramp and runway for ease of aircraft ground handling on snow/ice
- A Water source
- C In hangar
- B 1-3/4 in. line or larger
- B Electrical power supply (110, 220, 440 VAC, data van)
- C Shop air
- B FSS close by
- C Weather forecasting close by
- C Crash rescue on field
- C Hospital close by

TOP 7-3-537
12 February 2009

FACILITIES (CONTINUED)

- C Covered parking for data van
- C TM reception (high terrain or buildings that mask signal)
- B Antenna location (remote)

AREA SUPPORT

- B Sheet metal facilities
- B Welding shop
- C Hydraulic shop
- A Fuel
 - C JP-4
 - Jet-A
 - Mogas
- C Aviator oxygen
- C Nitrogen
- B Motor vehicle support
 - Tugs capable of pulling a loaded CH-47 on ice
 - Forklifts high enough to work on aircraft
 - Heaters, generators, tankers
- C Electronic lab
- B Rapid response shipping facilities (air freight)
- B Transportation hub (travel to and from test location)
- B Quarters for 35-50 people
- B Messing for 35-50 people
- C Recreation close by
- B Photographic supplies and processing capabilities
- C Mil address (for shipping parts)
- C Electronic supply (Radio Shack)
- C Industrial area
 - Local vehicle transportation for 35-50 people
- C GSA
- B GSA contract
- C Rental cars

ICING SITE SURVEY - 1984

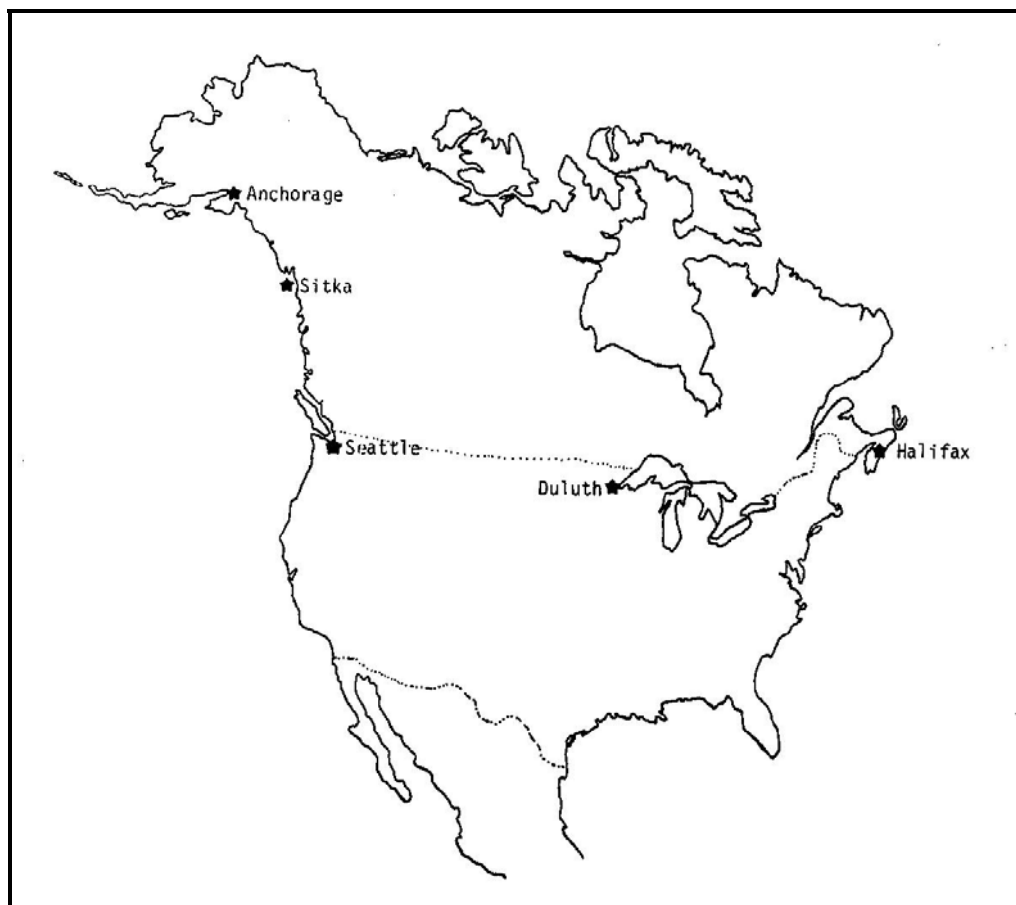
**Location****Comments**

Spokane, WA	Scarce natural ice
Moses Lake, WA	Scarce natural ice
Fort Lewis/McChord AFB, WA	Poor artificial icing conditions
Camp Ripley, MN	No hangar
St. Paul, MN	No hangar space available
Fort McCoy, WI	Inadequate hangar space
Volk Field, WI	Inadequate hangar space
KI Sawyer, MI	Limited hangar space available
Camp Drum, NY	Limited artificial and natural icing conditions
International Falls, MN	Inadequate hangar space
Duluth, MN	

TOP 7-3-537
12 February 2009

DULUTH, MN – TEST SITE ANALYSIS

- ◆ Good climate for both artificial and natural icing (also good for high Mach number testing)
- ◆ Excellent hangar and office space
 - Heated
 - Floor space accommodates HISS, C-12, test article, and SAR aircraft
 - Newly renovated office spaces and utilities
 - Flight operations/briefing area
 - Sheltered storage space for ground support equipment
 - Vast workshop areas
 - Separate office space for customers to accommodate privacy, meetings, etc.
- ◆ Air Guard support available on field
 - Fuel
 - Sheet metal, welding, and hydraulic shops
 - Precision measurement equipment lab
 - Source for loan of equipment
 - Packing, crating, and shipping
 - Snow removal and security
- ◆ Low air traffic and excellent air traffic control (50 mile radius)
 - More productive testing
 - Flights can be accomplished near airfield to minimize chance of offsite landings in case of emergency
- ◆ Adequate transportation hub/near major hub
- ◆ Sparse population near airport
- ◆ Assuming license for hangar facilities:
 - Deployment flexibility
 - Early identification/fix for problems and retesting in same icing season
 - More programs in one season
 - Better planning resulting in time and money savings (no searching/reinventing)
 - Amortizing capital improvements (phone, power, telemetry, hover pads, etc.)
- ◆ Political considerations
 - Duluth is an economically depressed area
 - Excellent support from and rapport with local government/business
 - Air Guard welcomes us

Duluth Climatology in Winter Months

Month	Precipitation (in)	Relative Humidity (%)	Temperature (°F)	Cloud Coverage ¹ (days)
Nov	1.7	75	28	20 C / 6 PC / 5 CLR
Dec	1.3	75	14	19 C / 6 PC / 6 CLR
Jan	1.2	72	6	17 C / 6 PC / 7 CLR
Feb	0.9	70	12	15 C / 6 PC / 7 CLR
Mar	1.8	70	23	17 C / 7 PC / 7 CLR

NOTES:

¹C – Cloudy (8/10)

PC – Partly cloudy (4/10 – 7/10)

CLR – Clear (3/10)

²Winds: West northwest all months**Huntsville Climatology in Winter Months**

Month	Precipitation (in)	Relative Humidity (%)	Temperature (°F)	Cloud Coverage ¹ (days)
Nov	4.9	70.0	51.5	14 C / 7 PC / 9 CLR
Dec	5.9	70.5	42.9	18 C / 6 PC / 8 CLR
Jan	5.2	56.5	38.8	18 C / 6 PC / 7 CLR
Feb	4.9	73.5	43.1	16 C / 6 PC / 7 CLR
Mar	6.6	71.0	51.9.	17 C / 8 PC / 7 CLR

NOTES:

¹C – Cloudy (8/10)

PC – Partly cloudy (4/10 – 7/10)

CLR – Clear (3/10)

²Winds: ??

TOP 7-3-537
12 February 2009

Duluth Climatology Compared with Other Icing Site Locations

Location	Mean High Temperature (°F)		Mean Low Temperature (°F)		No. Days Below 32°F		No. Days Below 0°F		Supercooled Stratus and Low Cumulus Cloud (%)		Average Freezing Level (ft)		Probability of Encountering Icing Below 10,000 ft (%)		Mean Precipitation (in)	
	Nov	Dec	Nov	Dec	Nov	Dec	Nov	Dec	Nov	Dec	Nov	Dec	Nov	Dec	Nov	Dec
Duluth	35	23	21	7	27	30.9	2.3	10.7	>5	<5	6500-9800	Surf	5-10	5-10	1.8	1.1
Seattle	52	48	39	37	5.6	6.1	0	0	<5	>5	6500-9800	Surf-3300	2.5-5	5	1.2	1.0
Halifax	47	36	30	18	16	27	-	-	>5	>25	6500-9800	Surf	5	5	5.3	5.4
Anchorage	35	24	20	8	-	-	-	-	>5	25	Surf-3300	Surf	5-10	5-10	1.0	0.9
Sitka	45	34	30	18	-	-	-	-	<5	>25	3300-6500	Surf-3300	5-10	5-10	15	12
Bangor	45	32	30	16	19.2	28.8	0	3.0	>5	>5	6500-9800	Surf	5	5-10	4.7	4.1
Huntsville	62	53	41	33	-	-	-	-	-	-	-	-	-	-	4.9	5.9

APPENDIX D. ABBREVIATIONS

SYMBOLS

°C	- °C
°F	- °F
N_g	- gas generator speed
N_r	- main rotor speed

ABBREVIATIONS

AEFA	- U.S. Army Aviation Engineering Flight Activity
AFCS	- automatic flight control system
AMRDL	- U.S. Army Aviation Mobility Research and Development Laboratory
APU	- auxiliary power unit
AR	- Army Regulation
ASN	- U.S. Army serial number
ATTC	- U.S. Army Aviation Technical Test Center
AWR	- airworthiness release
CAPS	- Cloud, Aerosol, and Precipitation Spectrometer
CAS	- Cloud Aerosol Spectrometer
CCP	- Cloud Combination Probe
CDP	- Cloud Droplet Probe
CIP	- Cloud Imaging Probe
CT	- Cloud Technology, Inc.
DC	- direct current
DMT	- Droplet Measurement Technology
DOD	- Department of Defense
DTC	- US Army Developmental Test Command
EOT	- element on time
ESSS	- external stores support system
FAT	- free air temperature
FM	- frequency modulation
FMS	- flight management system
FOD	- foreign object damage
FSSP	- forward-scattering spectrometer probe
IAW	- in accordance with
IFR	- instrument flight rules
LWC	- liquid water content

TOP 7-3-537
12 February 2009

MARSA - military accepts responsibility for separation of aircraft
MRI - Meteorological Research Incorporated

OAP - optical array probe
OAT - outside air temperature

PMI - Particle Metrics Incorporated

RDECOM - U.S. Army Research, Development, and Engineering Command

SEA - Science Engineering Associates, Inc.

VHF - very high frequency
VOR - VHF omnidirectional ranging

APPENDIX E. GLOSSARY*

Anti-icing: Preventing ice formation or buildup on a protection surface. This occurs by either evaporating the impinging water or by allowing it to run back and off the surface or to run back and freeze on non-critical areas.

Artificial ice: A structure formed from material other than frozen water, but intended to represent an ice accretion. See “simulated ice shapes.”

Clear ice: See “glaze ice.”

Collection efficiency: See “water catch efficiency.”

Critical ice shape: The aircraft surface ice shape formed within required icing conditions. It results in the most adverse effects for specific flight safety requirements. For an aircraft surface, the critical ice shape may differ for different requirements (for example, stall speed, climb, aircraft controllability, control surface movement, control forces, air data system performance, dynamic pressure probes for control force “feel” adjustment, ingestion and structural damage from shed-ice, engine thrust, engine control, and aeroelastic stability).

Critical aircraft ice shape configuration: The ice-contaminated aircraft configuration that results in the most adverse effects for specific flight safety requirements.

Critical surface: A surface whose integrity affects safe aircraft takeoff, flight, and landing. A surface that accretes ice and affects safe aircraft takeoff, flight, and landing is a critical surface for in-flight icing.

Deice or deicing: The periodic shedding or removal of ice buildups from a surface. This occurs by destroying the bond between the ice and the protection surface.

Empirical validation/evaluation: Validation or evaluation of analytical results by experimental data.

Failure ice: Aircraft ice accretion following failure of the ice protection system (IPS), or its components.

Forecast icing conditions: Meteorological conditions that an FAA-approved weather provider expects to be conducive to forming ice on aircraft in flight.

Freezing drizzle (FZDZ): Precipitation at ground level or aloft in the form of liquid water drops. The drizzle drop diameters are less than 0.5 mm and greater than 0.05 mm. Freezing drizzle exists at air temperatures less than 0°C and colder (supercooled), remains in liquid form, and freezes on contact with objects on the surface or airborne.

Freezing fraction (n): The amount of impinging water that freezes at the point of impingement.

TOP 7-3-537
12 February 2009

Freezing precipitation: Freezing rain or drizzle falling through or outside a visible cloud.

Freezing rain (FZRA): Precipitation at the ground level or aloft in the form of liquid water drops. The raindrop diameters are greater than 0.5 mm. Freezing rain exists at air temperatures less than 0°C (supercooled), remains in liquid form, and freezes on contact with objects on the surface or airborne.

Frost Point: The temperature at which water vapor saturates from an air mass into solid usually forming snow or frost. Frost point normally occurs when a mass of air has a relative humidity of 100%.

Glaze ice: Sometimes glaze ice is clear and smooth. Glaze ice usually contains some air pockets that result in a lumpy translucent appearance. Glaze ice results from supercooled drops striking a surface but not freezing rapidly on contact. Glaze ice is denser, harder, and sometimes more transparent than rime ice. Factors, which favor glaze formation, are those that favor slow dissipation of the heat of fusion (i.e., slight supercooling and rapid accretion). With larger accretions, the ice shape typically includes “horns” protruding from unprotected leading edge surfaces. Flight crews are more likely to assess the ice shape, rather than the clarity or color of the ice, accurately from the cockpit. The terms “clear” and “glaze” have been used for essentially the same type of ice accretion.

Heavy icing: A descriptor used operationally by flight crews when they report encountered icing intensity to air traffic control. The rate of ice buildup requires maximum use of the ice protection systems to minimize ice accretions on the airframe. A representative accretion rate for reference purposes is more than 3 inches (7.5 cm) per hour on the outer wing. A pilot encountering such conditions should consider immediate exit from the conditions.

Ice accretion limit: The location farthest aft on a body at which ice accretes. You may measure this distance either as the streamwise distance from the leading edge, or as the surface distance from the stagnation point. This document defines the icing limit as the streamwise distance from the leading edge.

Ice bridging: Classic pneumatic deicing boot ice bridging occurs when a thin layer of ice is sufficiently plastic to deform to the shape of the inflated deicing boot. This occurs without the thin ice breaking or shedding during ensuing cycling of the deicing boot. As the deformed ice hardens and accretes more ice, the deicing boot becomes ineffective. Ice bridging may occur when enough supercooled water freezes during the inflated deicing boot dwell period. It will keep that shape after the deicing boot deflates and will form a deformed surface that continues to accrete ice and is unaffected by ensuing cycling of the deicing boot. A deicing boot ice bridge may also form when flying into increasingly colder ambient temperature conditions following a mixed-phase icing encounter at near-freezing temperatures. Ice bridging also refers to the ice “caps” or “bridges” between adjacent component surfaces. For example, unprotected leading edge surfaces of an elevator horn and the horizontal stabilizer.

Ice evidence probe: Device that accretes ice before ice accretes on the airframe or its components. You may use ice evidence probes as a visual icing cue.

Ice ridge: Formation of a ridge of ice typically aft of the ice protection surface. Runback ice or large drops impinging aft of the protection surface can cause ice ridges to form.

Icing encounter: An exposure to continuous or broken icing conditions until a gap or interruption longer than some preselected distance (for example, 1 nautical mile (nm)) or duration (for example, 1 minute) occurs.

Icing in cloud: Icing occurring within visible cloud. Cloud drops (diameter < 50 μm) will be present; freezing drizzle or freezing rain, or both, may be present.

Icing in precipitation: Icing occurring from an encounter with freezing precipitation (supercooled drops with diameters exceeding 0.05 mm, within or outside a visible cloud).

Impingement limit: The location farthest aft on a body where water drops impinge. This distance is usually measured as the surface length from the surface's leading edge.

Intercycle ice: Ice that builds up on a deiced surface and exists immediately before the deice system is activated.

Known or observed or detected ice accretion: Ice observed visually on the aircraft by the flight crew or identified by onboard sensors.

Lagrangian drop trajectory computation: A method for calculating the trajectory of water drops in the surrounding airflow. These trajectories are typically calculated by determining the forces exerted on individual drops. The calculation proceeds by sequentially calculating forces and resulting motion as the drop moves through the flowfield surrounding the body of interest (for example, the wing, fuselage, engine inlet, etc.). The drop trajectory calculation finishes when the drop either impacts on the body or passes it.

Langmuir distribution: A family of theoretical drop size distributions. The distributions are based on the percentages of liquid water content of each drop size (Appendix I of this AC).

Light icing: A descriptor used operationally by flight crews when they report encountered icing intensity to traffic control. The rate of ice buildup requires occasional cycling of manual deicing systems to minimize ice accretions on the airframe. A representative accretion rate for reference purposes is 1/4 inch to one inch (0.6 to 2.5 cm) per hour on the outer wing. The pilot should consider exiting the condition.

Liquid water content (LWC): The mass of water in liquid cloud drops within a unit volume of cloud. It is usually given in units of grams of water per cubic meter of air (g/m^3).

Local water catch efficiency (β): The ratio of dY to ds . dY is the freestream distance between two drop trajectories that intersect a surface near a point P a distance ds apart. Letting ds approach 0, the value of β at P is the derivative dY/ds (Figure E-1).

TOP 7-3-537
12 February 2009

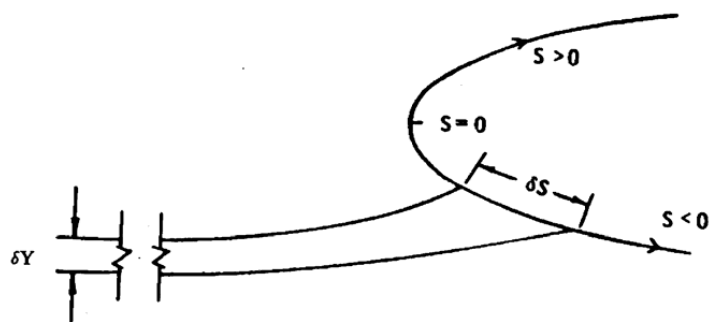

$$\beta = \lim_{\delta S \rightarrow 0} \frac{\delta Y}{\delta S} = \frac{dY}{dS}$$

Figure E-1. Definition of Local Impingement Efficiency Parameter, β

Lower horn angle: The angle of the lower horn of a glaze ice shape, lower, calculated with the polar direction from the wing chord plane (Figure E-2).

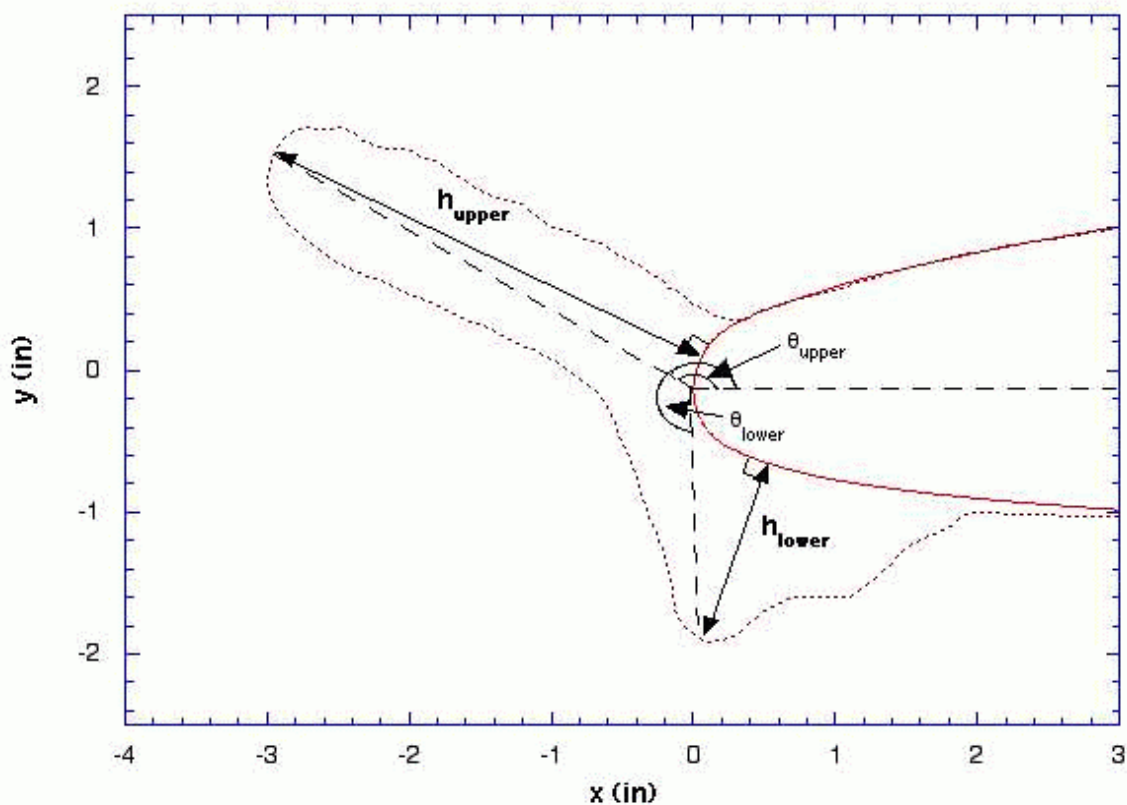

Figure E-2. Definition of Horn Maximum Thickness Angle

Ludlam limit: The value of LWC when the maximum rate of freezing can occur on a surface for a given combination of surface temperature, airspeed, altitude, and drop collection efficiency.

Mean effective diameter (MED): The drop diameter which divides the total water volume present in the drop distribution in half; so, half the water volume will be in larger drops and half the volume in smaller drops. The value is based on an assumed drop size distribution

Median volume diameter (MVD): The drop diameter that divides the total water volume present in the drop distribution in half; so, half the water volume will be in larger drops and half the volume in smaller drops. The value is based on an assumed drop size distribution present in the drop distribution in half; so, half the water volume will be in larger drops and half the volume in smaller drops. The value is obtained by actual drop size measurements.

Mixed ice: A simultaneous appearance or a combination of rime and glaze ice characteristics. Accurate identification of mixed ice from the cockpit may be difficult since the clarity, color, and shape of the ice will be a mixture of rime and glaze characteristics.

Mixed-phase icing conditions (mixed conditions): Partially glaciated clouds at an ambient temperature below 0°C. The clouds contain ice crystals and supercooled liquid water drops.

Moderate icing: A descriptor used operationally by flight crews to report encountered icing intensity to traffic control. The rate of ice buildup requires frequent cycling of manual deicing systems to minimize ice accretions on the airframe. A representative accretion rate for reference purposes is 1 to 3 inches (2.5 to 7.5 cm) per hour on the outer wing. The pilot should consider exiting the condition as soon as possible.

Monitored surface: The surface of concern regarding ice hazard (for example, the leading edge of a wing).

Natural icing flight tests: Flight tests performed in icing conditions that occur in a naturally formed cloud.

Potential icing conditions: Atmospheric icing conditions that airframe manufacturers typically define in terms of temperature and visible moisture that may result in aircraft ice accretion on the ground or in flight. The potential icing conditions are typically defined in the airplane flight manual or in the airplane operation manual.

Preactivation ice: Protected surface ice accretion that occurs before the ice protection system becomes fully effective.

Protected surface: A surface containing ice protection. The protected surface is typically located at the surface's leading edge.

Protection surface: The active surface of an ice protection system (for example, the surface of a deicing boot or thermal ice protection system).

TOP 7-3-537

12 February 2009

Reference surface: The observed (directly or indirectly) surface used as a reference for ice presence on the monitored surface. Ice presence on the reference surface must occur before, or coincidentally with, ice presence on the monitored surface. Examples of reference surfaces include windshield wiper posts, ice evidence probes, propeller spinners, and the metric sensor surface of ice detectors. The reference surface may also be the monitored surface.

Residual ice: Ice that remains on a protected surface immediately after deicing system actuation.

Rime ice: A rough, milky, opaque ice formed by the rapid freezing of supercooled drops after they strike the aircraft. The rapid freezing results in trapped air. The trapped air gives the ice its opaque appearance and makes it porous and brittle. Rime ice typically accretes along the stagnation line of an airfoil and is more regular in shape and conforms more to the airfoil than glaze ice. Crew are more likely to assess the ice shape, rather than the clarity or color of the ice accurately from the cockpit.

Runback ice: Ice that forms from the freezing or refreezing of water leaving protected surfaces and running back to unprotected surfaces.

Running wet: Defines heat requirements for running wet anti-icing that are based on maintaining an above-freezing surface temperature. This allows some of the impinging water to run back and freeze aft of the heated area or off the surface.

Running wet system: Any anti-icing system that supplies enough heat to prevent impinging water drops from freezing on the heated surface. A running wet system does not supply enough heat for complete evaporation.

Separated flow: A flow condition in which the flow is no longer attached to the surface. This phenomenon is associated with vortex formation and large energy losses in the flow. Separated flow typically results in losses in lift, increased drag, and reduced control effectiveness of lifting surfaces.

Severe icing: A descriptor used operationally by flight crews reporting encountered icing intensity to traffic control. The rate of ice buildup results in the inability of the ice protection systems to remove the buildup of ice satisfactorily. Also, ice builds up in locations not normally prone to icing, such as areas aft of protected surfaces and any other areas identified by the manufacturer. Immediate exit from the condition is necessary.

Shedding: Ice shedding is the act of separating or breaking away accreted ice from an aircraft part. Ice may shed by passive means for any aircraft surface (for example, by the natural aerodynamic or centrifugal forces) or by active means for protected surfaces of the aircraft (for example, by a deicing system).

Simulated ice shapes: Ice shapes made of wood, epoxy, or other materials by any construction technique. Simulated or artificial ice shapes can be designed and manufactured to reproduce ice shapes accumulated during simulated icing conditions. Simulated critical ice shapes may be tested during certification of ice protection systems. (See critical ice shapes and validation.)

Simulated icing: The process of creating simulated ice, for example, accumulating ice on an aircraft or aircraft surface by using a spray array, in an icing tunnel or behind an icing tanker.

Supercooled drops: Water drops that remain unfrozen at temperatures below 0°C. Supercooled drops exist in clouds, freezing drizzle, and freezing rain in the atmosphere. These drops may impinge and freeze after contact on aircraft surfaces.

Supercooled large drops (SLD): Liquid drop with diameters greater than 0.05 mm at temperatures less than 0°C, i.e., freezing rain or freezing drizzle.

Total water catch efficiency (E): The total amount of water or ice that impinges on the aircraft surface. It is the integrated value of the local catch. For a two-dimensional (2D) body (for example, on an airfoil) the total catch is more conveniently expressed as a unit span. An alternative (and equivalent) measurement (for a 2D case) is the weighted average of the water catch efficiencies shown in equation B-3.

Upper horn angle: The angle of the upper horn of a glaze ice shape, α_{upper} , calculated with the polar direction from the wing chord plane :

$$E = \frac{\int \beta c ds}{\int c ds}$$

Validation: The process that confirms that a computer code is functioning correctly; documentation and code version control meet the standards of the validating organization; and that predicted ice shapes match accepted experimental data, according to accepted validation standards (within established tolerances).

Verification: The process of determining that implementation of algorithms (for example, a computer code) accurately represents the developer's conceptual description of a problem solution. The code should accurately implement the mathematical rules or procedures used to solve the problem.

Water catch: The mass of water captured between the upper and lower impingement limits during a specified interval of time.

Water catch efficiency (β): The ratio of actual water drops mass flux at the surface to the water drops mass flux in the freestream when water drop paths are straight lines. It is also known as the collection efficiency, impingement efficiency, or local impingement efficiency.

* Glossary Terms Extract from FAA Advisory Circular 20-73A, Aircraft Icing Protection and other sources.

APPENDIX F. REFERENCES

1. Technical Note, ATTC TN 90-01, *Operation and Maintenance Procedures for CH-47 Helicopter Icing Spray System*, ATTC, Draft, with changes.
2. *Aeronautical Information Manual*, Department of Transportation, Current Edition.
3. US Army Developmental Test Command Test Operations Procedure (TOP) 7-3-057, Pitot-Static System Calibration, 10 April 2007.

For information only:

- a. Department of the Army Pamphlet, DA Pam 73-1, *Test and Evaluation in Support of System Acquisition*, 30 May 2003.
- b. Army Regulation, AR 200-2, *Environmental Analysis of Army Actions*, 29 March 2002.
- c. Technical Manual, TM 1-1510-240-10, *Operator's Manual for Army Model CH-47D Helicopters (EIC:RCD)*, 30 June 2006, with Change 2, 15 February 2007.
- d. TM 1-1510-222-10, *Operator's Manual for Army RC-12G Aircraft*, 10 December 1985, with Change 7, 20 April 1998.
- e. Memorandum, U.S. Army Research, Development and Engineering Command (RDECOM), AMSAM-AMR-AE-C, 16 July 2008, subject: Airworthiness Release for Flight Operations of US Army CH-47D Helicopter, Bearcat 2, with Helicopter Icing Spray System (HISS) and Other Modifications Installed (TN 591 8 1).
- f. Memorandum, RDECOM, AMSRD-AMR-AE-I-BF, 8 February 2007, subject: Airworthiness Release for Operations of JRC-12G Aircraft Number 80-23380 with Avionics Upgrade (TN 40679).
- g. Technical Note, *Icing Tests*, ATTC, Draft, with latest changes.
- h. Military Standard, MIL-STD-882D, *Standard Practice for System Safety*, 10 February 2000.
- i. Periodical, *Flight Information Handbook*, DOD Flight Information Publication (En route), Defense Mapping Agency Aerospace Center, current issue.
- j. Handbook, DOT/FAA/CT-88-8-1, *Aircraft Icing Handbook*, Volume 1, Department of Transportation, Federal Aviation Administration, March 1991, revised September 1993.
- k. Report, USAAMRDL-TR-75-34A (Lockheed-California Company Report LR 27180), *The Development of an Advanced Anti-icing/Deicing Capability for U.S. Army Helicopters, Volume 1 Design Criteria and Technology Considerations*, AMRDL, November 1975.

TOP 7-3-537
12 February 2009

- l. TM, AWSM 105-39, *Forecaster's Guide on Aircraft Icing*, U.S. Air Force Air Weather Service, January 1969; superseded by AWS/TR-80/001, March 1980.
- m. AR 310-25, *Military Publications, Dictionary of United States Army Terms (Short Title: AD)*, 21 May 1986.
- n. DTC Regulation 70-25, *Research, Development, and Acquisition, Protection of Human Test Subjects*, 11 July 2005, Draft.
- o. TOP 1-2-610, *Human Factors Engineering, Part 1, Test Procedures*, 15 May 1990.
- p. Federal Aviation Administration Advisory Circular Number 20-73A, *Aircraft Ice Protection*, 16 August 2006.

TOP 7-3-537
12 February 2009

Comments, recommended changes or any pertinent data which may be of use in improving this publication should be forwarded to the following address: Test Business Management Division (TEDT-TMB), US Army Developmental Test Command, 314 Longs Corner Road, Aberdeen Proving Ground, MD 21005-5055.. Technical information may be obtained from the preparing activity: Flight Test Directorate (TEDT-AC-FT) US Army Aviation Technical Test Center, Building 30137, Cairns Army Airfield, Fort Rucker, AL 36362-5276. Additional copies can be requested through the following website: <http://itops.dtc.army.mil/RequestForDocuments.aspx>, or through the Defense Technical Information Center, 8725 John J. Kingman Rd., STE 0944, Fort Belvoir, VA 22060-6218. This document is identified by the accession number (AD No.) printed on the first page.