

**TECHNICAL MANUAL**

**MAINTENANCE OF MECHANICAL  
AND ELECTRICAL EQUIPMENT  
AT COMMAND, CONTROL,  
COMMUNICATIONS,  
COMPUTERS, INTELLIGENCE,  
SURVEILLANCE, AND  
RECONNAISSANCE (C4ISR)  
FACILITIES**

**SYSTEM DESIGN FEATURES**

APPROVED FOR PUBLIC RELEASE: DISTRIBUTION IS UNLIMITED

## **REPRODUCTION AUTHORIZATION/RESTRICTIONS**

This manual has been prepared by or for the Government and, except to the extent indicated below, is public property and not subject to copyright.

Reprint or republication of this manual should include a credit substantially as follows: “Department of the Army TM 5-692-2 Maintenance of Mechanical and Electrical Equipment at Command, Control, Communications, Computers, Intelligence, Surveillance, and Reconnaissance (C4ISR) Facilities – System Design Features, *15 April 2001.*”

APPROVED FOR PUBLIC RELEASE; DISTRIBUTION IS UNLIMITED

## Maintenance of Mechanical and Electrical Equipment at C4ISR Facilities

### System Design Features

		<i>Paragraph</i>	<i>Page</i>
CHAPTER 1.	INTRODUCTION		
	Purpose	1-1	1-1
	Scope	1-2	1-1
	References	1-3	1-1
	Standard of performance	1-4	1-1
CHAPTER 2.	SYSTEMS ENGINEERING CONSIDERATIONS		
	General systems considerations	2-1	2-1
	Program elements	2-2	2-1
CHAPTER 3.	DIESEL ENGINES		
	Diesel engine ratings	3-1	3-1
	Types of diesel engines	3-2	3-1
	Diesel engine major system components	3-3	3-1
	Diesel engine system interfaces	3-4	3-2
	Operation of diesel engines	3-5	3-4
CHAPTER 4.	GAS TURBINES		
	Applications of gas turbines	4-1	4-1
	Gas turbine operating characteristics	4-2	4-1
	Gas turbine system major components	4-3	4-1
	Gas turbine system interfaces	4-4	4-4
CHAPTER 5.	FUEL OIL SYSTEMS		
	Simple fuel oil system	5-1	5-1
	Complex fuel oil system	5-2	5-1
	Fuel oil system major components	5-3	5-3
CHAPTER 6.	LUBE OIL SYSTEMS		
	Lube oil system design features	6-1	6-1
	Lube oil system major components	6-2	6-9
CHAPTER 7.	ENGINE INTAKE AND EXHAUST SYSTEMS		
	Engine intake and exhaust system design features	7-1	7-1
	Engine intake and exhaust system major components	7-2	7-4

		<i>Paragraph</i>	<i>Page</i>
CHAPTER 8.	<b>COOLING SYSTEMS</b>		
	Cooling system design features	8-1	8-1
	Cooling system major components	8-2	8-9
CHAPTER 9.	<b>BOILERS</b>		
	Types of boilers	9-1	9-1
	Types of systems	9-2	9-1
	Boiler system major components	9-3	9-2
	Boiler system controls	9-4	9-3
CHAPTER 10.	<b>INCINERATORS</b>		
	Incineration system description	10-1	10-1
	Incineration system major components	10-2	10-1
CHAPTER 11.	<b>CHILLED WATER SYSTEMS</b>		
	Chilled water systems description	11-1	11-1
	Chilled water systems major components	11-2	11-1
CHAPTER 12.	<b>DOMESTIC WATER SYSTEMS</b>		
	Domestic water system description	12-1	12-1
	Domestic water system major components	12-2	12-1
CHAPTER 13.	<b>CHEMICAL TREATMENT</b>		
	Chemical treatment system design features	13-1	13-1
	Chemical treatment system major components	13-2	13-6
CHAPTER 14.	<b>AIR HANDLING SYSTEMS</b>		
	Air handling system design features	14-1	14-1
	Air handling system major components	14-2	14-6
CHAPTER 15.	<b>INDUSTRIAL WATER SUPPLY SYSTEMS</b>		
	Industrial water supply system design features	15-1	15-1
	Industrial water supply system major components	15-2	15-2
	Testing	15-3	15-3
CHAPTER 16.	<b>COMPRESSED AIR SYSTEMS</b>		
	Compressed air system	16-1	16-1
	Compressed air system major components	16-2	16-1
	Compressed air system interfaces	16-3	16-8
CHAPTER 17.	<b>PNEUMATIC CONTROLS</b>		
	Pneumatic control design features	17-1	17-1
	Pneumatic control systems major components	17-2	17-1
	System operation	17-3	17-3
CHAPTER 18.	<b>SANITARY WASTE SYSTEMS</b>		
	General sanitary waste systems	18-1	18-1
	Sanitary waste system design features	18-2	18-1
	Sanitary waste system applications	18-3	18-1
	Treatment methods	18-4	18-2

	<i>Paragraph</i>	<i>Page</i>
Typical sanitary waste systems	18-5	18-3
Sludge handling, treatment, and disposal	18-6	18-7
Disinfection	18-7	18-7
Flow measurement, sampling, and process control	18-8	18-8
CHAPTER 19. GENERATORS		
Generator usage	19-1	19-1
Generator operation	19-2	19-1
Generator types	19-3	19-2
AC generators	19-4	19-2
DC generators	19-5	19-5
Major design components	19-6	19-6
CHAPTER 20. PRIMARY ELECTRICAL DISTRIBUTION		
General primary electrical distribution	20-1	20-1
Substations	20-2	20-1
Overhead distribution	20-3	20-4
Switchgear	20-4	20-5
Circuit breakers	20-5	20-6
CHAPTER 21. SECONDARY ELECTRICAL DISTRIBUTION		
General secondary electrical distribution	21-1	21-1
Switchgear, switchboards, and panelboards	21-2	21-1
Transformers	21-3	21-1
Power line conditioners	21-4	21-1
Motor control centers	21-5	21-3
Protective devices, fuses, and circuit breakers	21-6	21-3
Switches	21-7	21-4
Feeder cables	21-8	21-5
Controls	21-9	21-5
CHAPTER 22. STATIC UNINTERRUPTIBLE POWER SUPPLY		
General	22-1	22-1
Battery and battery charger	22-2	22-1
Inverter	22-3	22-3
Transfer switches	22-4	22-4
Instrumentation	22-5	22-5
Operational considerations	22-6	22-5
CHAPTER 23. ROTARY UNINTERRUPTIBLE POWER SUPPLY		
General rotary uninterruptible power supply	23-1	23-1
Rotary UPS design features	23-2	23-1
CHAPTER 24. MOTOR GENERATORS		
General motor generators	24-1	24-1
Motor generator design features	24-2	24-1

		<i>Paragraph</i>	<i>Page</i>
CHAPTER 25.	<b>ELECTRICAL CONTROLS</b>		
	Generalelectrical controls	25-1	25-1
	Major components of an electrical control system	25-2	25-1
CHAPTER 26.	<b>ELECTRONIC SECURITY</b>		
	Electronic security methodology	26-1	26-1
	Types of electronic security	26-2	26-1
CHAPTER 27.	<b>HEMP PROTECTION SYSTEMS</b>		
	General HEMP protection systems	27-1	27-1
	HEMP procedures	27-2	27-1
	Modes of HEMP entry	27-3	27-2
	Equipment susceptibility	27-4	27-2
	HEMP protection systems	27-5	27-3
CHAPTER 28.	<b>TEMPEST PROTECTION SYSTEMS</b>		
	GeneralTEMPEST protection systems	28-1	28-1
	Sources	28-2	28-1
	Acquisition	28-3	28-1
	Protection	28-4	28-1
CHAPTER 29.	<b>GROUNDING</b>		
	Generalgrounding systems	29-1	29-1
	Types of grounding	29-2	29-1
	Grounding systems	29-3	29-3
	Ground system materials and testing requirements	29-4	29-4
CHAPTER 30.	<b>LIGHTNING PROTECTION</b>		
	General lightning protection systems	30-1	30-1
	Lightning effects on power systems	30-2	30-1
	Principles of protection	30-3	30-2
	Lightning protection systems equipment requirements	30-4	30-3
CHAPTER 31.	<b>CATHODIC PROTECTION</b>		
	Generalcathodic protection systems	31-1	31-1
	Types of cathodic protection systems	31-2	31-1
	Application of cathodic protection	31-3	31-2
	Cathodic protection system design	31-4	31-3
CHAPTER 32.	<b>BLAST PROTECTION AND DETECTION SYSTEM</b>		
	Generalblast protection and detection systems	32-1	32-1
	Sensors	32-2	32-1
	Relay panels	32-3	32-1
	Blast valve systems	32-4	32-1
	Blast door systems	32-5	32-1
CHAPTER 33.	<b>FIRE PROTECTION</b>		
	General fire protection systems	33-1	33-1
	Fire detection systems	33-2	33-1
	Fire suppression systems	33-3	33-2

	<i>Paragraph</i>	<i>Page</i>
APPENDIX A. REFERENCES		A-1
GLOSSARY		G-1

### LIST OF FIGURES

<i>Figure</i>	<i>Title</i>	<i>Page</i>
Figure 5-1	Complex fuel oil system - supply	5-2
Figure 6-1	General lube oil system – diesel engine	6-2
Figure 6-2	General lube oil storage and dispensing system	6-3
Figure 6-3	Lube oil purification system	6-4
Figure 6-4	Emergency service diesel engine lube oil system	6-6
Figure 6-5	Primary service diesel engine lube oil system	6-7
Figure 6-6	Diesel engine standby operation lube oil heating system	6-8
Figure 7-1	Blast-protected air intake system	7-3
Figure 7-2	Blast-protected engine exhaust system	7-5
Figure 7-3	Blast-protected exhaust system	7-6
Figure 8-1	Examples of engine cooling systems (1)	8-2
Figure 8-2	Examples of engine cooling systems (2)	8-3
Figure 8-3	Examples of engine cooling systems (3)	8-4
Figure 8-4	Typical primary service diesel engine cooling system	8-6
Figure 8-5	Typical radiator diesel engine cooling system	8-8
Figure 8-6	Typical evaporative cooling tower	8-10
Figure 10-1	Vertical dual chamber incinerator	10-2
Figure 11-1	Variations of centrifugal pumps	11-5
Figure 11-2	Typical valves used in water service (1)	11-8
Figure 11-3	Typical valves used in water service (2)	11-9
Figure 12-1	Domestic water system with reservoir storage	12-2
Figure 12-2	Bladder tank installation	12-4
Figure 12-3	Electric water heater	12-5
Figure 12-4	Instantaneous steam water heater	12-6
Figure 12-5	Semi-instantaneous steam water heater	12-7
Figure 12-6	Backflow preventors	12-8
Figure 13-1	Typical fill system pot feeder installation	13-3
Figure 13-2	Typical pot feeder bypass installation	13-4
Figure 13-3	Open-loop chemical treatment system	13-5
Figure 13-4	Typical steam boiler installation	13-6
Figure 13-5	Basic water softener system	13-7
Figure 13-6	Basic ion exchange unit	13-8
Figure 14-1	Typical single zone air handling system	14-2

<i>Figure</i>	<i>Title</i>	<i>Page</i>
Figure 14-2	Multizone air handling system	14-3
Figure 14-3	Basic dual duct act handling system	14-4
Figure 14-4	Air handling system with reheat	14-5
Figure 14-5	Variable air volume air handling system	14-7
Figure 14-6	Typical air handling system controls	14-15
Figure 16-1	Typical air compressor systems	16-2
Figure 16-2	Typical air dryers	16-3
Figure 16-3	Typical air compressor installation	16-4
Figure 16-4	Typical engine compressed air starting system	16-5
Figure 17-1	Basic compressed air supply to pneumatic control system	17-2
Figure 18-1	Typical trickling filter process treatment train	18-4
Figure 18-2	Conventional plug flow activated sludge flow diagram	18-5
Figure 18-3	Septic tank	18-8
Figure 18-4	Lift station with wet pit vertical centrifugal pump	18-9
Figure 18-5	Pneumatic sewage ejector	18-10
Figure 18-6	Gate valve and swing check valve	18-11

**LIST OF TABLES**

<i>Table</i>	<i>Title</i>	<i>Page</i>
Table 3-1	Typical alarm and shutdown requirements for diesel engines	3-3
Table 4-1	Typical alarm and shutdown requirements for gas turbines	4-3
Table 7-1	Typical bellows material failures	7-8



**APPROVED FOR PUBLIC RELEASE; DISTRIBUTION IS UNLIMITED**

## Maintenance of Mechanical and Electrical Equipment at C4ISR Facilities

### System Design Features

		<i>Paragraph</i>	<i>Page</i>
CHAPTER 1.	<b>INTRODUCTION</b>		
	Purpose	1-1	1-1
	Scope	1-2	1-1
	References	1-3	1-1
	Standard of performance	1-4	1-1
CHAPTER 2.	<b>SYSTEMS ENGINEERING CONSIDERATIONS</b>		
	General systems considerations	2-1	2-1
	Program elements	2-2	2-1
CHAPTER 3.	<b>DIESEL ENGINES</b>		
	Diesel engine ratings	3-1	3-1
	Types of diesel engines	3-2	3-1
	Diesel engine major system components	3-3	3-1
	Diesel engine system interfaces	3-4	3-2
	Operation of diesel engines	3-5	3-4
CHAPTER 4.	<b>GAS TURBINES</b>		
	Applications of gas turbines	4-1	4-1
	Gas turbine operating characteristics	4-2	4-1
	Gas turbine system major components	4-3	4-1
	Gas turbine system interfaces	4-4	4-4
CHAPTER 5.	<b>FUEL OIL SYSTEMS</b>		
	Simple fuel oil system	5-1	5-1
	Complex fuel oil system	5-2	5-1
	Fuel oil system major components	5-3	5-3
CHAPTER 6.	<b>LUBE OIL SYSTEMS</b>		
	Lube oil system design features	6-1	6-1
	Lube oil system major components	6-2	6-9
CHAPTER 7.	<b>ENGINE INTAKE AND EXHAUST SYSTEMS</b>		
	Engine intake and exhaust system design features	7-1	7-1
	Engine intake and exhaust system major components	7-2	7-4

		<i>Paragraph</i>	<i>Page</i>
CHAPTER 8.	<b>COOLING SYSTEMS</b>		
	Cooling system design features	8-1	8-1
	Cooling system major components	8-2	8-9
CHAPTER 9.	<b>BOILERS</b>		
	Types of boilers	9-1	9-1
	Types of systems	9-2	9-1
	Boiler system major components	9-3	9-2
	Boiler system controls	9-4	9-3
CHAPTER 10.	<b>INCINERATORS</b>		
	Incineration system description	10-1	10-1
	Incineration system major components	10-2	10-1
CHAPTER 11.	<b>CHILLED WATER SYSTEMS</b>		
	Chilled water systems description	11-1	11-1
	Chilled water systems major components	11-2	11-1
CHAPTER 12.	<b>DOMESTIC WATER SYSTEMS</b>		
	Domestic water system description	12-1	12-1
	Domestic water system major components	12-2	12-1
CHAPTER 13.	<b>CHEMICAL TREATMENT</b>		
	Chemical treatment system design features	13-1	13-1
	Chemical treatment system major components	13-2	13-6
CHAPTER 14.	<b>AIR HANDLING SYSTEMS</b>		
	Air handling system design features	14-1	14-1
	Air handling system major components	14-2	14-6
CHAPTER 15.	<b>INDUSTRIAL WATER SUPPLY SYSTEMS</b>		
	Industrial water supply system design features	15-1	15-1
	Industrial water supply system major components	15-2	15-2
	Testing	15-3	15-3
CHAPTER 16.	<b>COMPRESSED AIR SYSTEMS</b>		
	Compressed air system	16-1	16-1
	Compressed air system major components	16-2	16-1
	Compressed air system interfaces	16-3	16-8
CHAPTER 17.	<b>PNEUMATIC CONTROLS</b>		
	Pneumatic control design features	17-1	17-1
	Pneumatic control systems major components	17-2	17-1
	System operation	17-3	17-3
CHAPTER 18.	<b>SANITARY WASTE SYSTEMS</b>		
	General sanitary waste systems	18-1	18-1
	Sanitary waste system design features	18-2	18-1
	Sanitary waste system applications	18-3	18-1
	Treatment methods	18-4	18-2

	<i>Paragraph</i>	<i>Page</i>
Typical sanitary waste systems	18-5	18-3
Sludge handling, treatment, and disposal	18-6	18-7
Disinfection	18-7	18-7
Flow measurement, sampling, and process control	18-8	18-8
CHAPTER 19. GENERATORS		
Generator usage	19-1	19-1
Generator operation	19-2	19-1
Generator types	19-3	19-2
AC generators	19-4	19-2
DC generators	19-5	19-5
Major design components	19-6	19-6
CHAPTER 20. PRIMARY ELECTRICAL DISTRIBUTION		
General primary electrical distribution	20-1	20-1
Substations	20-2	20-1
Overhead distribution	20-3	20-4
Switchgear	20-4	20-5
Circuit breakers	20-5	20-6
CHAPTER 21. SECONDARY ELECTRICAL DISTRIBUTION		
General secondary electrical distribution	21-1	21-1
Switchgear, switchboards, and panelboards	21-2	21-1
Transformers	21-3	21-1
Power line conditioners	21-4	21-1
Motor control centers	21-5	21-3
Protective devices, fuses, and circuit breakers	21-6	21-3
Switches	21-7	21-4
Feeder cables	21-8	21-5
Controls	21-9	21-5
CHAPTER 22. STATIC UNINTERRUPTIBLE POWER SUPPLY		
General	22-1	22-1
Battery and battery charger	22-2	22-1
Inverter	22-3	22-3
Transfer switches	22-4	22-4
Instrumentation	22-5	22-5
Operational considerations	22-6	22-5
CHAPTER 23. ROTARY UNINTERRUPTIBLE POWER SUPPLY		
General rotary uninterruptible power supply	23-1	23-1
Rotary UPS design features	23-2	23-1
CHAPTER 24. MOTOR GENERATORS		
General motor generators	24-1	24-1
Motor generator design features	24-2	24-1

		<i>Paragraph</i>	<i>Page</i>
CHAPTER 25.	<b>ELECTRICAL CONTROLS</b>		
	Generalelectrical controls	25-1	25-1
	Major components of an electrical control system	25-2	25-1
CHAPTER 26.	<b>ELECTRONIC SECURITY</b>		
	Electronic security methodology	26-1	26-1
	Types of electronic security	26-2	26-1
CHAPTER 27.	<b>HEMP PROTECTION SYSTEMS</b>		
	General HEMP protection systems	27-1	27-1
	HEMP procedures	27-2	27-1
	Modes of HEMP entry	27-3	27-2
	Equipment susceptibility	27-4	27-2
	HEMP protection systems	27-5	27-3
CHAPTER 28.	<b>TEMPEST PROTECTION SYSTEMS</b>		
	GeneralTEMPEST protection systems	28-1	28-1
	Sources	28-2	28-1
	Acquisition	28-3	28-1
	Protection	28-4	28-1
CHAPTER 29.	<b>GROUNDING</b>		
	Generalgrounding systems	29-1	29-1
	Types of grounding	29-2	29-1
	Grounding systems	29-3	29-3
	Ground system materials and testing requirements	29-4	29-4
CHAPTER 30.	<b>LIGHTNING PROTECTION</b>		
	General lightning protection systems	30-1	30-1
	Lightning effects on power systems	30-2	30-1
	Principles of protection	30-3	30-2
	Lightning protection systems equipment requirements	30-4	30-3
CHAPTER 31.	<b>CATHODIC PROTECTION</b>		
	Generalcathodic protection systems	31-1	31-1
	Types of cathodic protection systems	31-2	31-1
	Application of cathodic protection	31-3	31-2
	Cathodic protection system design	31-4	31-3
CHAPTER 32.	<b>BLAST PROTECTION AND DETECTION SYSTEM</b>		
	Generalblast protection and detection systems	32-1	32-1
	Sensors	32-2	32-1
	Relay panels	32-3	32-1
	Blast valve systems	32-4	32-1
	Blast door systems	32-5	32-1
CHAPTER 33.	<b>FIRE PROTECTION</b>		
	General fire protection systems	33-1	33-1
	Fire detection systems	33-2	33-1
	Fire suppression systems	33-3	33-2

	<i>Paragraph</i>	<i>Page</i>
APPENDIX A. REFERENCES		A-1
GLOSSARY		G-1

### LIST OF FIGURES

<i>Figure</i>	<i>Title</i>	<i>Page</i>
Figure 5-1	Complex fuel oil system - supply	5-2
Figure 6-1	General lube oil system – diesel engine	6-2
Figure 6-2	General lube oil storage and dispensing system	6-3
Figure 6-3	Lube oil purification system	6-4
Figure 6-4	Emergency service diesel engine lube oil system	6-6
Figure 6-5	Primary service diesel engine lube oil system	6-7
Figure 6-6	Diesel engine standby operation lube oil heating system	6-8
Figure 7-1	Blast-protected air intake system	7-3
Figure 7-2	Blast-protected engine exhaust system	7-5
Figure 7-3	Blast-protected exhaust system	7-6
Figure 8-1	Examples of engine cooling systems (1)	8-2
Figure 8-2	Examples of engine cooling systems (2)	8-3
Figure 8-3	Examples of engine cooling systems (3)	8-4
Figure 8-4	Typical primary service diesel engine cooling system	8-6
Figure 8-5	Typical radiator diesel engine cooling system	8-8
Figure 8-6	Typical evaporative cooling tower	8-10
Figure 10-1	Vertical dual chamber incinerator	10-2
Figure 11-1	Variations of centrifugal pumps	11-5
Figure 11-2	Typical valves used in water service (1)	11-8
Figure 11-3	Typical valves used in water service (2)	11-9
Figure 12-1	Domestic water system with reservoir storage	12-2
Figure 12-2	Bladder tank installation	12-4
Figure 12-3	Electric water heater	12-5
Figure 12-4	Instantaneous steam water heater	12-6
Figure 12-5	Semi-instantaneous steam water heater	12-7
Figure 12-6	Backflow preventors	12-8
Figure 13-1	Typical fill system pot feeder installation	13-3
Figure 13-2	Typical pot feeder bypass installation	13-4
Figure 13-3	Open-loop chemical treatment system	13-5
Figure 13-4	Typical steam boiler installation	13-6
Figure 13-5	Basic water softener system	13-7
Figure 13-6	Basic ion exchange unit	13-8
Figure 14-1	Typical single zone air handling system	14-2

<i>Figure</i>	<i>Title</i>	<i>Page</i>
Figure 14-2	Multizone air handling system	14-3
Figure 14-3	Basic dual duct act handling system	14-4
Figure 14-4	Air handling system with reheat	14-5
Figure 14-5	Variable air volume air handling system	14-7
Figure 14-6	Typical air handling system controls	14-15
Figure 16-1	Typical air compressor systems	16-2
Figure 16-2	Typical air dryers	16-3
Figure 16-3	Typical air compressor installation	16-4
Figure 16-4	Typical engine compressed air starting system	16-5
Figure 17-1	Basic compressed air supply to pneumatic control system	17-2
Figure 18-1	Typical trickling filter process treatment train	18-4
Figure 18-2	Conventional plug flow activated sludge flow diagram	18-5
Figure 18-3	Septic tank	18-8
Figure 18-4	Lift station with wet pit vertical centrifugal pump	18-9
Figure 18-5	Pneumatic sewage ejector	18-10
Figure 18-6	Gate valve and swing check valve	18-11

**LIST OF TABLES**

<i>Table</i>	<i>Title</i>	<i>Page</i>
Table 3-1	Typical alarm and shutdown requirements for diesel engines	3-3
Table 4-1	Typical alarm and shutdown requirements for gas turbines	4-3
Table 7-1	Typical bellows material failures	7-8

# CHAPTER 1

## INTRODUCTION

---

### 1-1. Purpose

This document has been prepared to provide generic guidance to agencies responsible for the development and implementation of maintenance programs for site utility systems at Command, Control, Communications, Computers, Intelligence, Surveillance, and Reconnaissance (C4ISR) sites. This technical manual (TM), TM 5-692-2, describes commonly implemented design features of various mechanical and electrical systems. TM 5-692-1, the companion manual to TM 5-692-2, describes the activities which must be performed to maintain mechanical and electrical equipment at a minimum level of operational readiness.

### 1-2. Scope

The program guidance and system specific maintenance requirements advanced in this manual are applicable in part or total to all C4ISR sites.

### 1-3. References

Appendix A contains a list of references used in this manual.

### 1-4. Standard of performance

The program guidance and system specific features described in this manual are considered to meet the minimum required standards of performance for such systems and must be augmented by equipment manufacturer's detailed operation and maintenance instructions and other site-specific design requirements as local mission reliability requirements dictate.

## CHAPTER 2

# SYSTEMS ENGINEERING CONSIDERATIONS

---

### 2-1. General systems considerations

Requirements are presented in this manual for the design of optimally reliable mechanical and electrical systems at Command, Control, Communications, Computer, Intelligence, Surveillance, and Reconnaissance (C4ISR) facilities. These systems shall be capable of supplying services continually to the C4ISR installation site during any natural or man-made disruption in commercial services. Off-site power facilities are assumed to be adequate to supply peak power demands, but are not assumed to be uninterrupted. Potential threats include physical attacks; biological, chemical, and radiological warfare; and close-in and high-altitude nuclear blasts.

### 2-2. Program elements

The essential elements of a systems engineering program are described below.

*a. Reliability, availability, and maintainability (RAM).* During design, the design agency shall implement RAM requirements to maximum the availability of the C4ISR systems.

*b. Human factors engineering (HFE).* HFE activities will ensure that reliability, availability, and safety of the C4ISR systems are not degraded through human activities during operation or maintenance. The design agency shall accomplish the HFE program requirements through the use of established standard HFE design criteria and practices based on MIL-STD-1472, Human Engineering Design Criteria for Military Systems, Equipment, and Facilities.

*c. System safety.* The C4ISR power system safety program shall ensure that the design incorporates, within program restraints, the highest attainable level of inherent safety. It shall eliminate or reduce the probability of events that can cause injury or death to personnel, or damage to or loss of equipment or property. For example, pipes, lines, and tanks shall be placed away from high-traffic areas. Safety documentation shall be provided for safety items that require designation or may cause action during subsequent program phases. The design agency system safety program shall be based on a philosophy that the most effective actions to control potential hazards are those taken early in the design process.

(1) When hazards cannot be controlled by design measures, including safety and warning devices, special operating procedures shall be developed and documented. The safety program shall provide support to the systems engineering (SE) program and shall ensure that the applicable requirements of MIL-STD-882, System Safety Program Requirements, are met.

(2) The systems safety program shall define and address the safety analyses that shall be performed during development of design. During the early design phase, an analysis that identifies conditions that may cause injury or death to personnel and damage or loss to equipment and property shall be performed. Prior to the final safety design review, the design agency shall perform a second systems safety analysis to determine adherence of the design to all required safety standards and criteria, and to ensure avoidance or reduction of identified hazards. Operating and maintenance procedures shall also be reviewed for compliance with all required safety standards and criteria.



(3) The systems safety program shall include follow-up/corrective procedures to ensure that safety hazards identified by the systems safety analyses are eliminated or reduced to acceptable levels of risk, and that actions taken are fully documented.

(4) The design agency shall prepare specific safety program documentation. This documentation shall include, but not be limited to, safety analysis reports and the final systems safety report.

*d. Consolidated system testing.* The design agency shall develop a consolidated systems test program that covers all phases of testing, develops confidence in the system, and provides means for interim and final acceptance of equipment and systems. The design agency shall minimize cost through elimination of testing duplication and by maximizing the collection of data for each test. Final acceptance of the system shall follow 100 percent successful completion of these tests.

*e. Standardization.* The design agency shall develop and implement a standardization program to minimize equipment and component stockage. Redundant systems shall be of the same design.

*f. Configuration management (CM).* The CM program shall maintain effective control over design from criteria development through design, construction, and installation of the equipment. A government configuration control procedure shall be developed by the design agency for use in the C4ISR configuration control program.

*g. Operations and maintenance (O&M) planning.* The design agency shall identify and recommend essential items of the program during the design phase. Basic elements of the program are as follows.

(1) Data requirements shall be identified for preparation of O&M manuals. Systems functional descriptions shall be developed. Requirements shall be developed for data collection, including repair parts list, calibration requirements, special tools and test equipment, repair parts stockage level, and shelf life data. Repair parts list, repair parts stockage level, test equipment, and test frequency shall be provided the using government agency.

(2) Systems and equipment of high complexity or peculiarity shall be identified, and special training for personnel who operate and maintain such systems and equipment shall be identified.

(3) The design agency shall identify those items critical to accuracy and repeatability, and shall recommend calibration requirements. Unique calibration requirements and procedures shall be provided whenever necessary.

(4) Systems test and checkout requirements to be performed following major maintenance activities shall be developed during design to ensure safe and normal operation of the system.

## CHAPTER 3

### DIESEL ENGINES

---

#### 3-1. Diesel engine ratings

Diesel engines are the most common prime movers used for remote or emergency electric power generation. Those engines used for this purpose commonly range from 133 hp to 6,700 hp (100 kW to 5,000 kW), with rotational speeds ranging from 360 rpm for large prime power applications to as high as 1,800 rpm for small standby units. Thermal efficiency ranges from 30 to over 40 percent. This chapter will primarily address the requirements of diesel engines in the middle range of capacity and speed which are the most common. The engine manufacturer's directions regarding maintenance practices take precedence over any guidance provided in this chapter.

#### 3-2. Types of diesel engines

Diesel engines are used as prime movers for many applications, but they are addressed here based on their use in electric power generation to drive generators.

*a. Configuration.* Diesel engines are available in two- or four-cycle configurations. Four-cycle engines are available in naturally aspirated or turbocharged models, but most engines are now purchased with turbocharging. Similarly, two-cycle engines are available with either a blower or turbocharger (some manufacturers use both in series), but turbochargers are supplied on most engines. Each type has its advantages in certain applications and has specific requirements for operation and maintenance due to the inherent differences. Two-cycle engines are frequently lighter weight for the same horsepower due to the fabrication of the engine block from steel plate instead of a casting and elimination of the valving common to four-cycle engines. In addition, they usually respond more quickly to rapidly changing loads, since they have less rotating mass than four-cycle engines.

*b. Applications.* Two major considerations in the level and amount of maintenance required for diesel engines are the application of the engine (emergency standby power or prime power) and the rotational speed of the engines. Emergency equipment which is expected to operate very few hours per year can be expected to last for years with minimal maintenance and utilize higher speed engines (i.e., 1,200 to 1,800 rpm). Prime power applications require significantly more maintenance and generally utilize lower speed engines (360 to 450 rpm) to maximize the useful life of components.

#### 3-3. Diesel engine major system components

Diesel engines have many components and subsystems. Only those components which are typically mounted on the engine or engine skid will be addressed here. Descriptions of engine support systems, such as the fuel oil system, starting system, and lubrication system, are presented later in this manual.

*a. Drivetrain.* The drivetrain of the engine consists of the pistons, connecting rods, crankshaft, flywheel, coupling if any, and associated bearings.

*b. Valve train and timing.* This subsystem includes the gearing from the crankshaft to the camshaft, camshaft, tappets, push rods, rocker arms, valves, valve springs, and guides. In addition, the camshaft

controls the fuel injection timing and actuates the injector in most contemporary engines with unit injectors. The description above applies to four-cycle engines; two-cycle engines move air into the cylinder and exhaust out through ports in the cylinder wall which are exposed by the movement of the piston. Some two-cycle engines have both ports and valves. Injection timing and actuation on two-cycle engines are still controlled by a camshaft.

*c. Governor/control.* The governor controls the speed of the engine. It is a sophisticated device which measures crankshaft speed and reacts to small deviations due to changes in load to maintain proper engine speed by adjusting the amount of fuel injected. Typically, two types of governors are used on diesel engines driving electric generators: self-contained mechanical-hydraulic type or remote electronic governor with separate engine-mounted actuator. Electronic governor systems with load sharing capability are the usual choice for multiple engine plants. Pulsating loads of some facilities have dictated the use of mechanical governors. Plants with multiple engines must have compatible governors to ensure proper operation of engines in parallel. Other control/safety alarm and shutdown indicators are summarized in table 3-1.

*d. Turbocharger/blower.* The turbocharger is a centrifugal compressor which is driven by the exhaust gases and in turn compresses the intake air to provide an increased mass of air to the combustion chamber. In-line engines typically have one turbocharger, and V type engines may have one or two turbochargers. Turbochargers are used on both two- and four-cycle engines, but many two-cycle engines utilize blowers to assist in scavenging air from the combustion chamber without significant increase in the density of the air.

*e. Aftercooler.* Turbocharged engines typically have an aftercooler downstream of the turbocharger to reduce the air temperature and increase the density of the air entering the combustion chamber. Cooling water is circulated through the aftercooler which is composed of finned tubes to cool the air to approximately 100°F.

### **3-4. Diesel engine system interfaces**

Diesel engines interface with the following supporting systems.

*a. Generators.* Generators are the primary driven equipment for diesel engines. The diesel engine and the generator must be properly aligned and coupled, either directly or by a flexible coupling. It is critical that the engine and generator are properly matched and a torsional analysis of the engine/generator system has been performed by the engine manufacturer.

*b. Fuel oil systems.* The diesel engine is dependent on the fuel oil system to provide fuel to the injectors. The fuel oil must have the proper characteristics required for the specific engine installation. In general, larger slow-speed engines require a less volatile fuel than smaller high-speed engines. Special engine modifications are required where special fuels, such as Diesel Fuel Arctic (DFA) or heavy oil (No. 6) are used. Fuel oil systems are addressed in chapter 5.

*c. Lube oil systems.* The proper lubrication of the moving parts inside a diesel engine is critical to obtain satisfactory operation of the engine and maximum life of its components. The lube oil must be approved by the engine manufacturer and analyzed on a regular basis to determine the optimum interval for changing the lube oil and to monitor other indicators which indicate problems or a need for maintenance. In addition, the analysis of the lube oil should include trace metal analysis for early indication of abnormal wear and scheduling maintenance or repairs. Lube oil systems cool and filter the lube oil to provide both proper lubrication and cooling of critical components within the engine. Refer to chapter 6

for further discussion of lube oil systems.

Table 3-1. Typical alarm and shutdown requirements for diesel engines

<i>Indication</i>	<i>Alarm Only</i>	<i>Alarm and Shutdown</i>
<b>Engine System</b>		
Overspeed		X
High Exhaust Temperature	X	
High Crankcase Pressure	X	
Low Injector Coolant Pressure	X	
High Inlet Manifold Temperature	X	
<b>Lube System</b>		
High Lube Oil Temperature	X	X
Low Lube Oil Pressure	X	X
Low Lube Oil Level	X	X
<b>Fuel System</b>		
High Fuel Oil Temperature	X	
Low Fuel Oil Pressure	X	X
High Fuel Filter Differential Pressure	X	
<b>Generator System</b>		
High Generator Bearing Temperature	X	X
High Generator Winding Temperature	X	X
<b>Ancillary Systems</b>		
High Coolant Temperature	X	
Low Coolant Level	X	
Low Jacket Water Pressure	X	
Low Starting Air Pressure	X	

*d. Engine air system.* The engine intake and exhaust systems provide filtered air to the engine and remove products of combustion from the engine room. These systems may incorporate such features as preheating or precooling of the intake air, or hardened design. Restrictions or blockage of either the intake or exhaust systems will severely impact engine performance.

*e. Engine cooling system.* Heat is transferred away from the engine by the cooling system and usually rejected to the air. The engine cooling system may consist of a single circuit which removes heat from the aftercooler and lube oil cooler, as well as the engine, or it may have separate circuits which allow lower temperatures to be maintained at the various components. The cooling system temperature is thermostatically maintained to ensure proper cooling and avoid thermal shock of high-temperature components. The heat is usually rejected directly through a radiator or indirectly via a heat exchanger to a cooling tower. The heat removed from the engine may be used to preheat combustion air in severe cold climates and also for heating the power plant building in prime power applications.

*f. Engine starting air system.* The vast majority of diesel engines installed in power plants are started with compressed air. Compressed air is directed by a distributor directly into the combustion chamber or is provided to an air motor which rotates the engine. Dedicated compressors typically provide starting air at 250 psig. The system must provide adequate storage to allow multiple attempts to start the engines.

*g. Engine control systems.* The basic control of the engine is maintained by the governor during operation, and the control is independent for each engine. The overall control of a multiple engine power plant can be relatively simple or very sophisticated. Possible control options range from local or manual starting and synchronization of each engine to automatic starting, synchronization, and load sharing of the engine generators.

*h. Instrumentation.* Collection of operating data is critical to planning maintenance and evaluating problems which may occur. In the past (and still the case at most facilities), all data were recorded by operating personnel from instrument panels at each engine. Many newer plants now have automated data logging systems which can also provide warnings for out-of-tolerance conditions and histories of unusual events which can improve the operation of the facility. Regardless of the type of system, data collection provides the basis for trend analysis which can indicate potential problems before they become severe.

*i. Ventilation systems.* Diesel engines operate at high temperatures and, therefore, reject large amounts of heat to the surrounding space. Diesel power plants are typically ventilated to remove this heat and to maintain temperatures within acceptable limits for both personnel and equipment. Proper operation of ventilation systems is required to avoid excessive temperatures, reduced equipment capacity, and potential equipment failures.

### **3-5. Operation of diesel engines**

Consult the diesel engine manufacturer's manual provided with the engine for proper operating procedures and normal operating conditions. The operating procedures described below provide a general overview of diesel engine operation.

*a. Prior to starting.* Prior to starting, the engine prelube pump should be operated to ensure proper lubrication of the bearing surfaces. The prelube pump for a standby unit should be operated on a regular basis to maintain engine in "ready to start" condition. All engine auxiliary systems should be checked to verify proper status for engine operation. Failure to properly prelube the engine prior to starting can result in damage to engine components and significantly decrease engine life.

*b. Starting.* Normal starting of the engine should include the following items. The engine should be started without load and brought up to operating temperature before load is applied, verify lube oil pressure is normal immediately after starting, and be prepared to shut engine down if problems occur.

*c. Normal operation.* Under normal circumstances, do not operate the engine below 50 percent load or above 100 percent load for extended periods of time. Operation at low loads can cause carbon formation and rapid deterioration of the lube oil. Operation at high loads results in higher temperatures and pressures in the combustion chamber and can lead to more frequent maintenance or replacement of components. Operators should verify proper operating conditions exist on an hourly basis, and data should be recorded at least once per shift. Priority should be given to maintaining correct lube oil and coolant levels and checking the pressure difference across the inlet air filters, fuel filters, and lube oil filters.

*d. Shutdown.* Diesel engine should be unloaded and allowed to cool down prior to shutdown of the unit. The engine should be operated without load at rated speed until exhaust temperature decreases to recommended level and then at low idle speed, if applicable, for a minimum of five minutes without load or as directed by manufacturer.

## CHAPTER 4

# GAS TURBINES

---

### 4-1. Applications of gas turbines

Gas turbines, also known as combustion turbines, are common prime movers for many applications. Their historically high fuel consumption, especially for small units (less than 10,000 kW), as well as at part load, and at high inlet air temperatures has made them less desirable than diesel engines for prime power plant applications. They have been utilized extensively in standby and peaking applications where their relatively low installed cost outweighs other factors. Open or simple cycle gas turbines are used in virtually all power plant applications and only this type will be addressed in this chapter. Combined cycle systems, where heat is recovered from the gas turbine exhaust and used to make steam which then drives a steam turbine, have become much more common in recent years, but they will not be discussed here.

### 4-2. Gas turbine operating characteristics

Gas turbines are based on the Brayton or Joule cycle which consists of four processes: compression with no heat transfer, heating at constant pressure, expansion with no heat transfer, and in a closed cycle system, cooling at constant pressure. In open cycle gas turbines, the fourth step does not exist since inlet air is taken from the atmosphere and the exhaust is dumped to atmosphere. Due to its higher temperature, there is more energy available from the expansion process than is expended in the compression. The net work delivered to drive a generator is the difference between the two. The thermal efficiency of the gas turbine is a function of the pressure ratio of the compressor, the inlet temperature of the power turbine, and any parasitic losses (especially the efficiency of the compressor and power turbine). Practical limitations on thermal efficiency due to losses and materials technology yield a maximum of about 40 percent at pressure ratios of 30 to 40 and temperatures of approximately 2,500°F. These temperatures and pressure ratios are found only in recently developed, large gas turbines. Typically pressure ratios of 5 to 20 and turbine inlet temperatures from 1,400 to 2,000°F are common in gas turbines for this application, resulting in efficiencies from 20 to 33 percent. As improved materials and cooling technologies are introduced to smaller units, the efficiencies can be expected to improve if the cost is not prohibitive.

### 4-3. Gas turbine system major components

Gas turbines can be divided into three major components or sections; these are the compressor, the combustor, and the power turbine. Air enters the compressor and is pressurized to a level from 10 to 50 times that of the entering air. The compressed air then passes into the combustor where fuel is introduced and ignited, producing temperatures in the range of 1,400 to 2,000°F. The hot gases are then directed to the power turbine where they are expanded to atmospheric pressure and in turn provide power to drive both the compressor and the driven equipment such as a generator. Gas turbine auxiliary systems/components include starting, fuel supply, lubrication, governor/controls, speed reduction gear, inlet air, and engine exhaust.

*a. Configuration.* Gas turbines are lightweight in comparison to diesel engines, are very compact, and due to their small, well-balanced rotating mass are able to operate at very high speeds (from 10,000 to 25,000 rpm in sizes from 900 to 10,000 kW). Smaller gas turbines are usually single-shaft design, that is the compressor and power turbine are mounted on the same shaft. Larger gas turbines are frequently

two-shaft machines in which the power turbine is divided into two sections, one of which drives the compressor and the other which drives the generator. The two-shaft design allows the compressor section to be operated at a variable speed (within limits) thus varying the flow to the power turbine section as a function of load.

*b. Starting system components.* Gas turbines utilize a variety of starting systems based on size of the unit and other considerations. Common starting methods include compressed air, direct current (DC) electric motors with dedicated batteries, or a hydraulic pump driven by an alternating current (AC) motor, small gas turbine, or diesel engine, which in turn drives the hydraulic motor on the gas turbine. Where used, an auxiliary gas turbine or diesel engine also requires a starting system, usually a DC motor and batteries. Regardless of the equipment used, the starting system brings the unit up to a minimum speed at which the burners may be ignited and the turbine is then brought up to operating speed.

*c. Fuel system components.* Although gas turbines are capable of burning either gas or liquid fuels, only liquid fuels are addressed in this chapter since they are preferred for standby power generation. The following fuel system components are commonly provided as part of the gas turbine package: motor driven booster pump, low-pressure duplex fuel filter, main turbine driven fuel pump, high pressure filter, main fuel control valve (regulated by the governor), fuel manifold and injectors at the combustor, and igniter.

*d. Lubrication system components.* Most gas turbines are provided with complete lubrication systems which include a cooler (air cooled), filter, pre/post lube pumps, engine driven main lube oil pump, alarms, oil storage tank (located in engine skid), and heater. The system is usually packaged with the gas turbine and only the lube oil cooler is remotely located. The lube oil system may supply the speed reduction gear and generator in addition to the gas turbine.

*e. Governor/control.* The gas turbine speed and fuel flow are controlled by the governor in response to load changes. Typically two types of governors are used on gas turbines driving electric generators: self-contained mechanical-hydraulic type or remote electronic governor with separate engine mounted actuator. Electronic governor systems with load sharing capability are the usual choice for multiple engine plants. Plants with multiple engines must have compatible governors to ensure proper operation of engines in parallel. Other control/safety alarm and shutdown indications are summarized in table 4-1.

*f. Speed reduction gear.* The high operating speeds of most gas turbines require that a speed reduction gear be installed to drive the generator at the appropriate synchronous speed, usually 1,200 to 1,800 rpm. The reduction gear is typically an epicyclic design that permits a straight-through shaft arrangement, thus simplifying alignment. A variety of epicyclic designs are used and depending on the speed of the gas turbine, a two-stage reduction may be required. Two common designs are the standard planetary system and the star compound system. The reduction gear is typically lubricated by the main lube oil system.

*g. Inlet and exhaust components.* Gas turbines require significantly more combustion air than diesel engines. Flows are typically four to five times as much as that required by a diesel engine of the same capacity. This leads to much larger air filters, intake ducts, and exhaust ducts. Proper air filtration is critical to gas turbine performance. Deposits on compressor and turbine blades can significantly reduce efficiency.



Table 4-1. Typical alarm and shutdown requirements for gas turbines

<i>Indication</i>	<i>Alarm Only</i>	<i>Alarm and Shutdown</i>
<b>Engine System</b>		
Impending High Blade Temperature	X	
High Blade Temperature		X
Impending High Engine Temperature	X	
High Engine Temperature		X
High Gas Producer Thrust Bearing Temperature	X	X
High Power Turbine Thrust Bearing Temperature	X	X
Fail to Crank		X
Fail to Start		X
Ignition Failure		X
Starter Dropout Failure		X
Backup Overspeed Power Turbine		X
Overspeed Power Turbine		X
High Vibration – Engine	X	X
High Vibration – Accessory Gearbox	X	X
<b>Lube System</b>		
High Oil Temperature	X	X
Low Oil Pressure	X	X
Low Pre-lube Oil Pressure		X
Low Oil Level	X	X
High Oil Level	X	
Lube Filter High Differential Pressure	X	
<b>Fuel System</b>		
Liquid Fuel Filter High Differential Pressure	X	
Low Liquid Fuel Pressure	X	X
<b>Gearbox Systems</b>		
High Gearbox Output Bearing Temperature	X	X
High Vibration – Gearbox	X	X
<b>Generator Systems</b>		
High Generator Bearing Temperature	X	X
High Generator Winding Temperature	X	X
High Vibration – Generator	X	X
<b>Ancillary Systems</b>		
Low Battery Voltage	X	
Battery Charger Failure	X	
Inlet Air Filter – High Differential Pressure	X	X

#### 4-4. Gas turbine system interfaces

Gas turbines interface with the following supporting systems.

*a. Generators.* Generators are the primary driven equipment for gas turbines. The gas turbine and the generator must be properly aligned and coupled, either directly or by a flexible coupling. It is critical that the engine and generator are properly matched.

*b. Fuel oil systems.* The gas turbine is dependent on the fuel oil system to provide fuel to the engine skid. The fuel oil must have the proper characteristics required for the specific engine installation. In general, gas turbines can utilize a wider range of liquid fuels than diesel engines. Most facilities use kerosene, No. 1 fuel oil, or No. 1 diesel, but some use No. 2 fuel (if acceptable to the manufacturer) since it is less expensive than the lighter grades of fuel.

*c. Lube oil systems.* The proper lubrication of the moving parts inside a gas turbine is critical to obtain satisfactory operation of the engine and maximum life of its components. The lube oil must be approved by the engine manufacturer and analyzed on a regular basis to determine the optimum interval for changing the lube oil. Lube oil change intervals are much longer than those for diesel engines, since the oil does not become contaminated by products of combustion. Lube oil systems cool and filter the lube oil to provide both proper lubrication and cooling of critical components within the engine.

*d. Engine air system.* The engine intake and exhaust systems provide filtered air to the engine and remove products of combustion from the engine room. These systems may be very simple or relatively complex, incorporating such features as preheating or precooling of the intake air, or hardened design. Restrictions or blockage of either the intake or exhaust systems will severely impact engine performance.

*e. Engines starting system.* Gas turbines installed in power plants may be started with compressed air, DC motors, or an engine driven hydraulic system. Dedicated compressors typically provide starting air at pressures from 150 to 500 psig, depending on the specific requirements of the gas turbine. The system must provide adequate storage of compressed air to allow multiple attempts to start the engines. DC motors are driven from batteries located at the engine skid, which are charged by a dedicated battery charger. Hydraulic systems are composed of a prime mover, usually a diesel engine or small gas turbine, hydraulic pump, drive motor, and accessories, including hydraulic reservoir, air cooled heat exchanger, and filter.

*f. Engine control systems.* The basic control of the engine is maintained by the governor during operation and the control is independent for each engine. The overall control of a multiple engine power plant can be relatively simple or very sophisticated. Possible control options range from local or manual starting and synchronization of each engine to automatic starting, synchronization, and load sharing of the engine generators.

*g. Instrumentation.* Collection of operating data is critical to planning maintenance and evaluating problems which may occur. In the past (and still the case at most facilities), all data was recorded by operating personnel from instrument panels at each engine. Many newer plants now have automated data logging systems that can also provide warnings for out-of-tolerance conditions and histories of unusual events which can improve the operation of the facility. Regardless of the type of system, data collection provides the basis for trend analysis that can indicate potential problems before they become severe.

*h. Ventilation systems.* Gas turbines operate at high temperatures and therefore reject large amounts of heat to the surrounding space. Power plants are typically ventilated to remove this heat and to maintain temperatures within acceptable limits for both personnel and equipment. Proper operation of ventilation systems is required to avoid excessive temperatures, reduced equipment capacity, and potential equipment failures.

## CHAPTER 5

# FUEL OIL SYSTEMS

---

### 5-1. Simple fuel oil system

In a simple fuel oil system there is only one device using fuel oil and the fuel oil tank is located close to the equipment being served which allows the tank to supply fuel oil to the equipment and receive returned oil without an intermediate service tank.

*a. Storage.* The fuel oil tank is a double wall, horizontal, cylindrical tank and could be located either above or below ground. Fuel oil is drawn out from the top of the tank by the fuel oil pump suction line. A top discharge is best for horizontal tanks. The suction line can be installed some distance from the bottom of the tank to prevent water separating from the fuel oil in the tank from entering the supply system. Tanks typically have a high suction and a low suction line. Normal operation is through the low suction line. If an accumulation of water enters the low suction line, facility operation can be switched to the high suction line until the accumulated water is removed. Once the water is removed, it is important to switch back to the low suction line. Fuel oil storage tank fill and return lines typically terminate in trap sections. In the event the tank is drawn down past these lines, the trap section minimizes the likelihood that combustible vapors can exit the tank and create a hazard within the facility. Also, the fuel oil supply piping has an expansion chamber which prevents expanding oil from leaking through joints and shaft seals or causing physical damage to the system.

*b. Fuel delivery.* The fuel oil used in the facility may require heating in cold weather to reduce the fuel oil viscosity into the pumpable range. The heating is provided by a steam or hot water coil surrounded by a box-like structure to form a suction heater. Fuel oil is drawn from the tank through a suction strainer by a fuel oil pump. The fuel oil is pumped through a coalescing filter to remove water and through an oil heater to reduce the fuel oil viscosity into the atomizing range. Fuel oil not used by the equipment is returned to the fuel oil storage tank. If the amount of hot oil returned is likely to cause the storage tank to fill with oil vapor, the return oil would be cooled to below the flash point by a fuel oil cooler before being discharged into the tank.

*c. Fuel selection.* Lighter weight fuel oils such as FS2, DF2, DFA, and JP fuels have a much lower viscosity, which allows them to flow more easily during cold weather. Unless the outside air temperature is extremely cold, pre-heaters are not normally required when using these fuels. Heavier oils such as FS4 (and especially FS6), due to their high paraffin content, do require the heaters in cold weather. The need for preheating should be considered by the facility in specifying the fuel requirements for new or replacement equipment such as boilers. The heavier fuels have a higher BTU content and are usually less expensive. However, the cost of preheating the fuel can easily make the lower viscosity fuels cheaper in the long run. Also, the higher viscosity fuels often have a higher sulfur content, which may present an air quality problem in certain areas

### 5-2. Complex fuel oil system

A more complex fuel oil system is shown on figure 5-1. The complex fuel oil supply system is serving a diesel engine unit that can run on less costly heavy fuel oil (No. 5 or No. 6), but requires a more expensive light fuel oil (No. 1-D, No. 2-D, No. 1, or No. 2) for starting the engine. In this instance, the

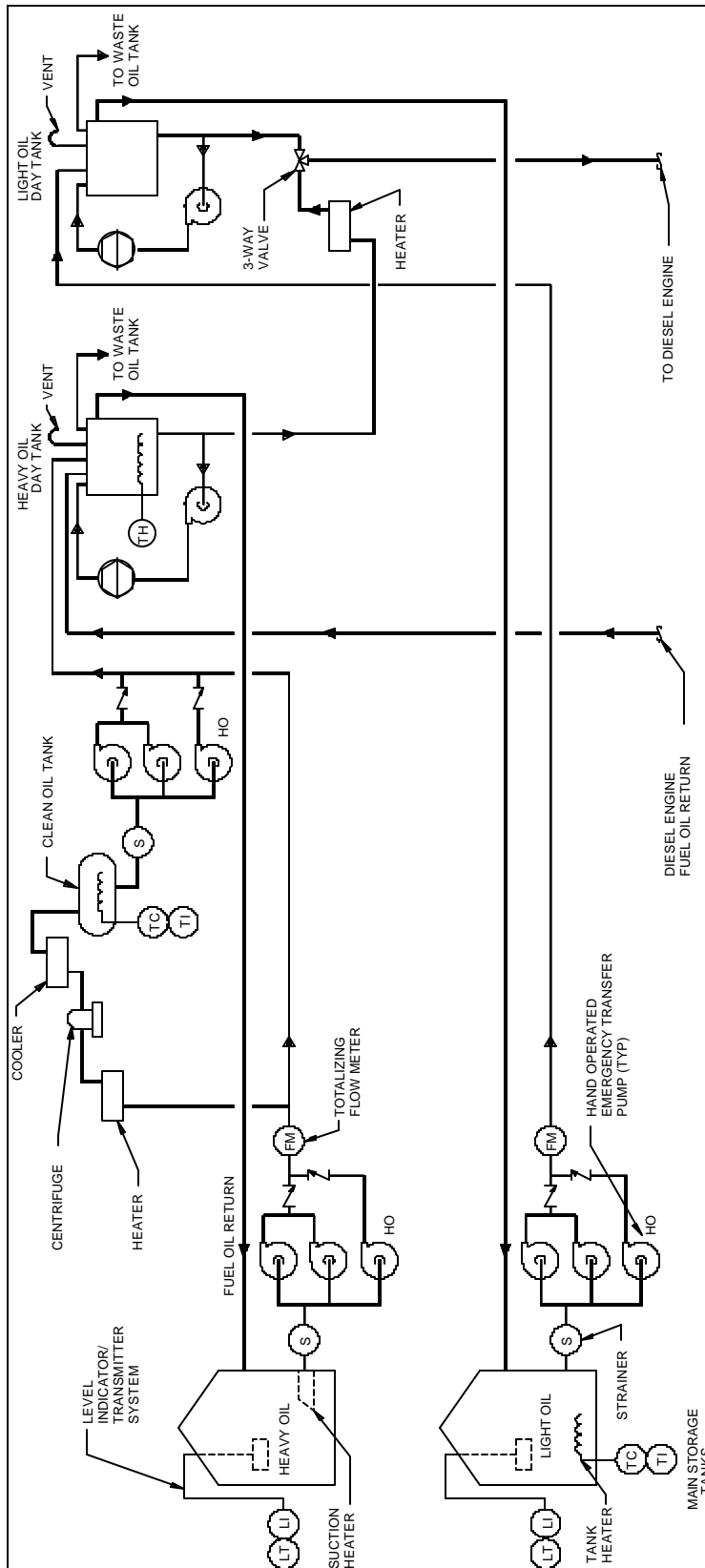

Figure 5-1. Complex fuel oil system - supply

quantity of fuel oil used by the facility requires a tank farm some distance from the point of use and the quality of the heavy oil requires on-site conditioning before use. Note that critical fuel oil transfer pumps have installed spares, and critical transfer points have hand-operated pumps in parallel with the motor-operated pumps to allow a minimum level of fuel transfer in the event of unplanned electric service supply outages.

*a. Storage.* The fuel oil storage tanks are equipped with level indicators and level transmitters. The heavy oil tank uses a suction heater to adjust oil viscosity while the light oil tank uses a whole tank heating system to maintain the oil above the pour point temperature. All aboveground piping and oil transfer equipment are heat-traced.

*b. Conditioning.* Because of the water and sediment in the as-delivered heavy fuel oil, the heavy fuel oil requires conditioning before final use. In the example system on figure 5-1, fuel oil conditioning is accomplished using a centrifuge. The heavy fuel oil feed to the centrifuge must be further heated to reduce the viscosity into the atomizing range. The fuel oil discharged from the centrifuge is passed through a fuel oil cooler to eliminate flash point problems before being discharged into a clean oil storage tank that is heated to keep the fuel oil viscosity at a pumpable level.

*c. Fuel delivery.* Heavy fuel oil is transferred from the clean oil tank to a heavy oil day tank at each diesel engine. Light fuel oil is transferred from the light oil main storage tank to the light oil day tank at each diesel engine. Both day tanks are equipped with systems to circulate the fuel oil through coalescing filters to remove any water in the fuel oil. The heavy fuel oil day tank is equipped with a heater to maintain the oil viscosity at a point that will flow to the engine. Additional heating of the heavy fuel oil is required to reduce the oil viscosity into the atomizing range as the oil is supplied to the engine.

(1) The heavy fuel oil and light fuel oil are supplied to the engine through a three-way valve. On initial starting, the three-way valve is positioned to use light fuel oil. Light fuel oil is used until the engine reaches operating speed and temperatures. Once the engine operation is stabilized, the three-way valve is positioned to supply heavy fuel oil to the engine. During a normal shutdown, the three-way valve is positioned to supply light fuel oil to the engine to purge the heavy oil from the engine fuel system before engine operation is terminated.

(2) The fuel oil day tanks are positioned above the engine so fuel oil is supplied by gravity to the inlet of the engine-driven fuel oil pump. Some installations may require self-priming, engine-driven fuel oil pumps to draw fuel into the pump, or there may be an additional set of pumps between the day tanks and the engine-driven pump to get the fuel oil to the engine-driven pump inlet. Whenever the engine fuel oil system has been drained, many engine designs require that the system be filled with fuel oil before a normal start is attempted and a hand-operated pump is provided for this purpose. Fuel oil supplied to the engine-driven fuel oil pump passes through a shutoff valve and a duplex strainer. The engine-driven fuel oil pump discharges through a duplex fuel oil filter to the engine fuel injection system. Excess fuel oil passes through an air-cooled fuel oil cooler, a check valve, and an engine fuel oil system isolation valve, and is returned to the heavy fuel oil day tank.

### **5-3. Fuel oil system major components**

The fuel oil system is comprised of the following major components.

*a. Fuel oil pipeline flowmeter.* The fuel oil pipeline flowmeter is a rotary displacement type flowmeter used to measure fuel oil quantities for accounting purposes.

*b. Fuel oil storage tank heaters.* Fuel oil storage tank heaters for outdoor aboveground tanks will vary in type as follows.

(1) Low watt density electric heating elements are arranged on the bottom of the fuel oil storage tank. Sometimes they are also designed to be flange-mounted through the side of the tank.

(2) Hot water is circulated through heat exchanger tubes that are immersed in the fuel oil. In most cases, the tube assembly is mounted through the side of the tank on a flanged nozzle.

(3) The heating of the fuel oil storage tank is similar to that used for a hot water system; only the heating medium is steam.

(4) A suction heater is designed to be mounted on or in the fuel oil storage tank suction nozzle that heats the fuel as it is drawn from the tank.

*c. Fuel oil supply heat tracing.* Heat tracing is installed on lines to maintain the temperature of the fuel oil in the lines to prevent viscosity or pour point problems. Heat-traced lines and equipment are generally insulated. Mechanical heat tracing is generally a tube clamped and thermally bonded to the outside of the fuel oil pipe. Steam or hot water is passed through the tubing. Electric heat tracing is by means of flexible resistance heaters that can be wrapped around the pipe.

*d. Strainers.* Strainers are used to remove coarse particulate matter that may damage rotating equipment. Typical strainers use a screen-like mesh or perforated metal element (Y type and basket type strainers) or closely spaced parallel rows of sharp-edged metal bar elements (metal-edge type strainer). They may include magnetic elements for removal of iron and steel particles. Duplex strainers have two strainer elements of equal capacity connected in parallel by a valve assembly that allows the process stream to be diverted from one strainer element to the other without interrupting flow. Duplex units are used in systems that cannot be conveniently shut down for maintenance.

*e. Fuel oil filters.* Fuel oil is filtered to remove particulate matter and to remove water. Filters designed to remove water from fuel oil are known as coalescing filters.

(1) Particulate filters are used to remove fine particulate from fuel oils. Filters in fuel oil systems are generally made up in cylindrically shaped "cartridges" or elements of a size convenient for handling. Unless the filter element is of the metallic, permanent type that can be cleaned, filter elements are typically used once and then discarded. In locations where the fuel oil system can be shut down for maintenance, single-element filter units are generally installed. In critical services, duplex filter units designed to allow switching from one bank of filter elements to another without interrupting the flow of fuel oil are generally used.

(2) Fuel oil systems typically use coalescing filters to remove water from the fuel oil. Coalescing filters are also extremely efficient particulate filters.

*f. Centrifuges.* The fuel oil conditioning system centrifuge is utilized for purification (separation of liquids) and clarification (removal of solids). This unit is generally a high-speed centrifuge with a self-cleaning bowl.

*g. Control valves.* Control valves are installed in the fuel oil supply lines inlet to day tanks. The valves automatically open when the fuel oil in their respective day tank falls to a preset level. When the

valve opens, fuel oil flows into the day tank. When the level in the tank reaches another preset (higher) level, the valves automatically close, stopping the flow of fuel. The operation of the control valves is controlled by level switches.

*h. Fuel oil day tanks.* Fuel oil day tanks are usually located at an elevation above the engines. The day tanks are generally a cylindrical type tank with a capacity for storing a four- to eight-hour supply of fuel oil. The tank has a manhole, a supply inlet connection, a vent connection, an overflow connection, a fuel return connection, a fuel supply outlet connection, and two connections for the level controller and indicator.

*i. Waste oil storage tank.* The waste oil storage tank is generally a cylindrical type and will be double-walled if located underground. The tank will have nozzles for vent, tank pump-out, fill, and level monitoring. Underground tanks may have a leak detection system, level indication, and overflow alarms.

*j. Pumps.* Various types of pumps are utilized in fuel oil systems.

(1) The pumps used to transfer fuel oil throughout the facility may vary from installation to installation. The types of pumps likely to be found in fuel oil service are as follows.

(a) Centrifugal pumps, horizontal, are preferred for pumping from aboveground tanks with continuously flooded pump suction when viscosity considerations or the pressure drop of filter devices following the pump are not a concern.

(b) Vertical centrifugal pumps may be used, but are not preferred, for pumping from underground tanks (or from horizontal, cylindrical tanks). These pumps may have multiple stages.

(c) Turbine pumps, vertical, are preferred for pumping from underground tanks.

(d) Positive displacement pumps are used where a relatively constant flow over a range of system pressures may be encountered, or when the viscosity of the fluid or the oil filtering system components require relatively high pump discharge pressures. In installations or service where a flooded pump suction line cannot be ensured, the pump should be of the self-priming type. Positive displacement pumps are common in fuel oil service. The three most common are rotary lobe, sliding vane, and gear type pumps.

(2) Fuel oil transfer pumps are generally rotary positive displacement type pumps equipped with integral pressure relief valves. The pumps are typically controlled by a locally mounted pump control panel.

(3) Hand-operated pumps are recommended for limited fuel oil transfer during unexpected outages of the electric motor-driven transfer pumps when the arrangement of the facility does not allow filling service tanks by gravity.

(4) The engine fuel oil pump supplies fuel oil to the engine fuel injector system at the required pressure for proper atomization of the fuel oil when the engine is operating. The fuel oil pump is usually mounted on the engine and is gear-driven from the engine. The engine-driven fuel oil pump is generally a positive displacement pump that is usually of the rotary lobe or gear type. Depending on the equipment manufacturer, the pump may be equipped with an internal pressure relief device that will return oil to the inlet side of the pump in the event the discharge of the pump is blocked.



(5) The engine priming pump is used to fill the fuel oil system any time the fuel system has been drained or opened for maintenance, or the engine has been out of service for an extended period of time. The priming pump is generally a hand-operated pump of the positive displacement type.

*k. Fuel oil.* The manufacturer's recommended fuels should only be used as specified in the equipment literature. In general, most fuel oils will be supplied in accordance with Federal Specification A-A-52557, Fuel Oil, Diesel; For Posts, Camps, and Stations; or Military Specification MIL-F-16884J, Fuel, Naval Distillate. Dirty fuels or fuels not meeting manufacturer's minimum specifications will adversely affect combustion, filter life, injection system performance, service life, and ability to start. They will also affect service life of valves, turbine blades, pistons, rings, liners, and bearings.

(1) A supplier should provide certified documentation prior to or with the fuel oil delivery, verifying that the oil has been tested by a certified laboratory and meets the specifications for the fuel oil used by the facility. If documentation is not provided for the fuel oil, the facility should sample and analyze the fuel oil prior to use. The facility should take samples of all fuel oil delivered to the facility and retain the samples until that lot of fuel oil is used. Even if certified test reports are provided by the supplier, the facility should periodically have independent analyses performed to ensure compliance with purchase order or contract requirements. A simple delivery test is to visually check the quality of fuel oil delivered by collecting a sample of every fuel oil delivery in a clear, clean, dry, glass bottle. As each sample is taken, tightly cap the bottle and identify the bottle with information, such as date, supplier identification, purchase order, specification, etc. Allow the sample to settle for at least 8 hours, and compare it with a similar bottle containing a fuel oil known to be of acceptable quality. A cloudy appearance suggests that fine droplets of water are entrained in the fuel which, in time, will settle to the bottom of the sample. Any contamination in gasoline or kerosene (lighter fractions) will float and collect at the top of the bottle. Contaminants, such as pipe scale or other foreign solids, will settle and collect at the bottom of the sample. If doubt exists as to the quality or identity of the fuel oil after the visual examination, the sample should be laboratory-analyzed for compliance with the specification.

(2) A periodic inspection of stored fuel and fuel systems is important to ensure reliable engine performance. Many engine failures are caused by fuel contamination. The following in-service testing suggestions are given for preventing and/or detecting post delivery fuel contamination.

(a) Monitor storage tanks (main tanks, intermediate tanks, day tanks, etc.) for accumulations of water, and remove water frequently.

(b) Keep storage tanks as full as possible (especially in cold weather).

(c) Do not mix different grades of fuel oil.

(d) Use oldest fuel oil inventory first. Long-term storage may result in the formation of sludge or the growth of soluble and insoluble bacteria that can clog fuel filters and injectors. If sludge in filters is noticed, switch to a different fuel oil supply and have suspect supply tested. If suspect supply is found to be unacceptable, discard unacceptable fuel oil.

(e) When strainers are cleaned or filters are changed, carefully inspect elements for unusual amounts of rust, scale, or sediment. If unusual amounts are observed, inspect fuel oil storage and delivery system upstream of the strainer or filter to determine and correct the cause of the contamination.

## CHAPTER 6

# LUBE OIL SYSTEMS

---

### 6-1. Lube oil system design features

A general facility lube oil system serving a diesel engine is shown on figure 6-1. As shown, a system may consist of storage tanks, interconnecting piping and piping components, instrumentation and controls, filtration equipment (strainers and filters), pumps, conditioning equipment (centrifuge), heaters, and heat exchangers.

*a. Central lube oil storage and dispensing system.* A central lube oil storage and dispensing system may consist of a clean lube oil receiving, storage, and supply system, and a dirty lube oil return and storage system. Where the facility is large, the system may also include intermediate storage tanks located at the points of lube oil use. A central lube oil storage and dispensing system with intermediate storage tanks is shown on figure 6-2. It is sometimes possible to remove the contaminants from dirty lube oil and recycle the cleaned lube oil to the clean oil system for reuse. A typical lube oil purification system is shown on figure 6-3.

(1) Clean lube oil may be received in bulk shipment. The bulk delivery unit may be equipped with a self-contained pumping unit, or an external pump which is part of the facility lube oil system (figure 6-2) may be required. In either case, facilities should have a strainer unit installed in the main lube oil tank fill line to minimize particulates entering the lube oil distribution system. The clean lube oil tank may also receive clean lube oil from intermediate storage tank overflows.

(a) The main clean lube oil tank may be equipped with some type of level gauge. The gauge may only have local readout capabilities, or a transmitter element may be part of the gauge so that the level in the tank can be monitored from a remote location. The tank may also be equipped with a level switch that activates an alarm when the lube oil level in the tank exceeds a preset level and is in danger of overflowing. This level switch may also be interlocked with the tank fill pump to turn the pump off, or may close a valve in the fill line. Depending on local climate, lube oil tanks installed outdoors or in unheated spaces may be equipped with a tank heater.

(b) A clean oil supply pump distributes the clean lube oil to end use points (figure 6-1) or, in large facilities, distributes the clean lube oil to intermediate storage facilities (figure 6-2). Typically, the clean oil supply pump operates only as needed. In many facilities, this allows clean lube oil supply and dirty lube oil disposal or centrifuge feed piping to be interconnected so that one pump system serves as the clean oil supply pump, the dirty oil disposal pump, and the lube oil purification system feed pump.

(c) Intermediate storage tanks (figure 6-2) may be used in large facilities to place a supply of lube oil close to an operation within the larger facility and allow that operation to supply individual user points within the operation from the intermediate tank. The intermediate tanks may be equipped with the same types of gauges, level switches, and control devices as the main storage tanks. Clean lube oil may be delivered by gravity or, as shown on figure 6-1, by a pump to a manual dispensing point or to the makeup lube oil connection on a piece of equipment.

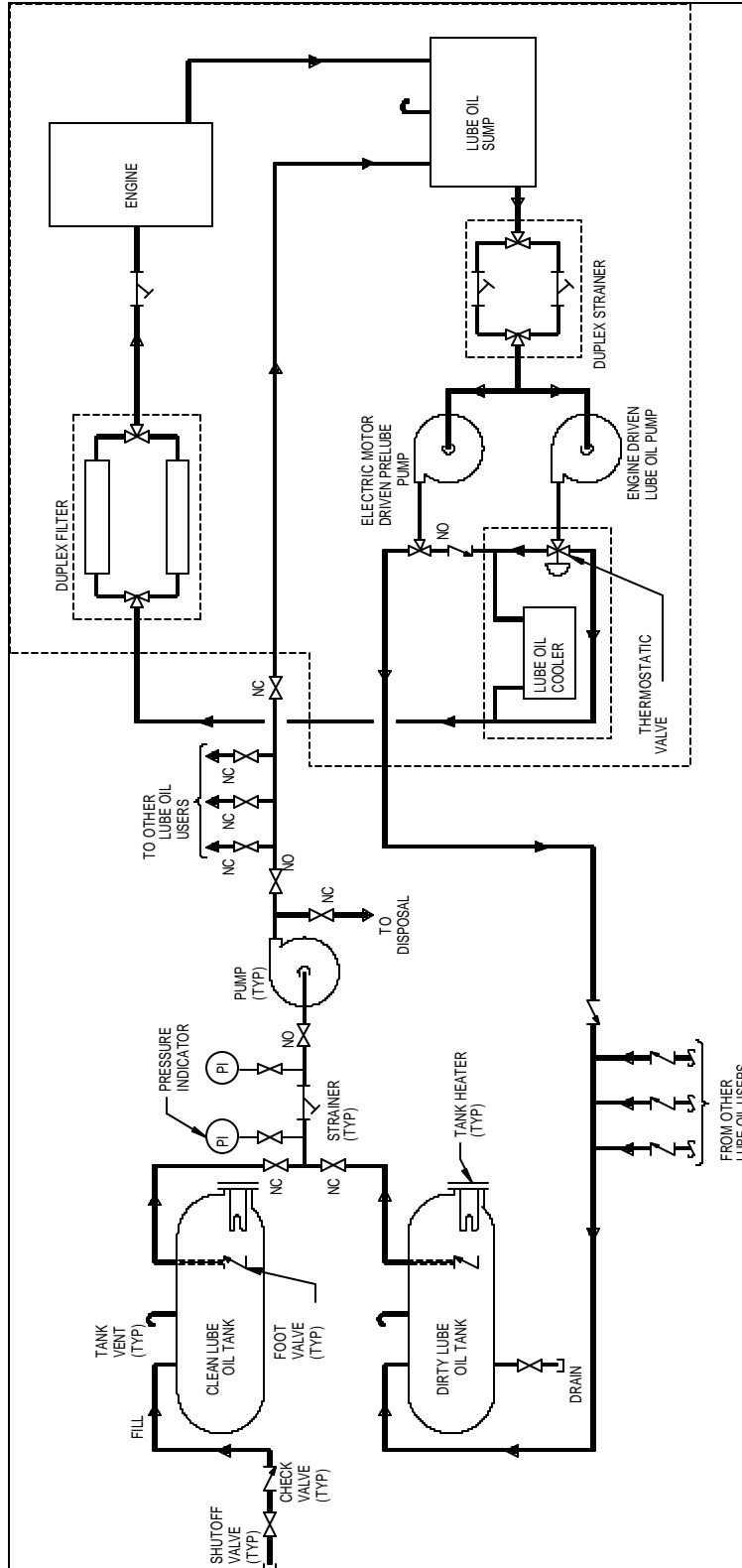

Figure 6-1. General lube oil system – diesel engine

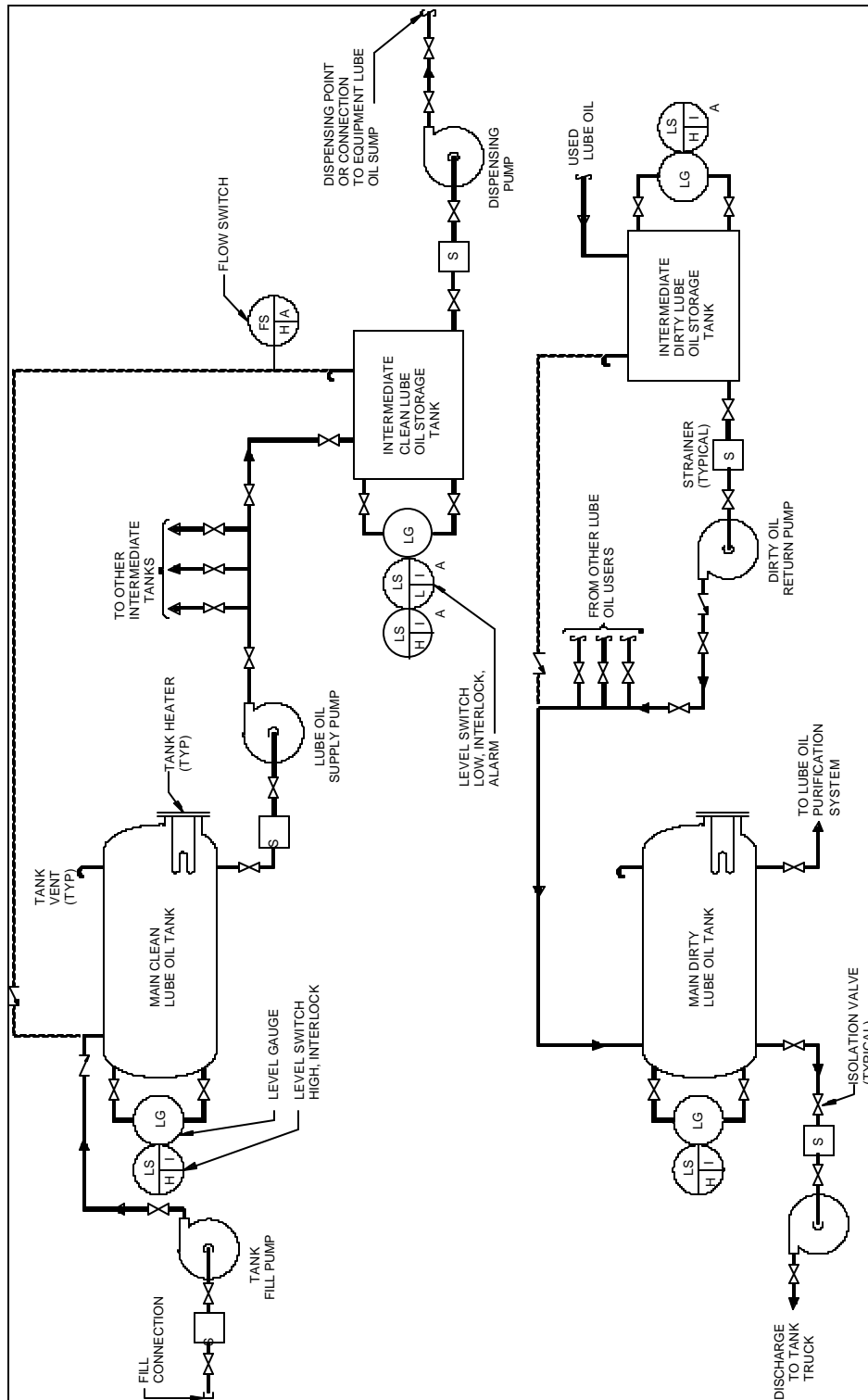

Figure 6-2. General lube oil storage and dispensing system

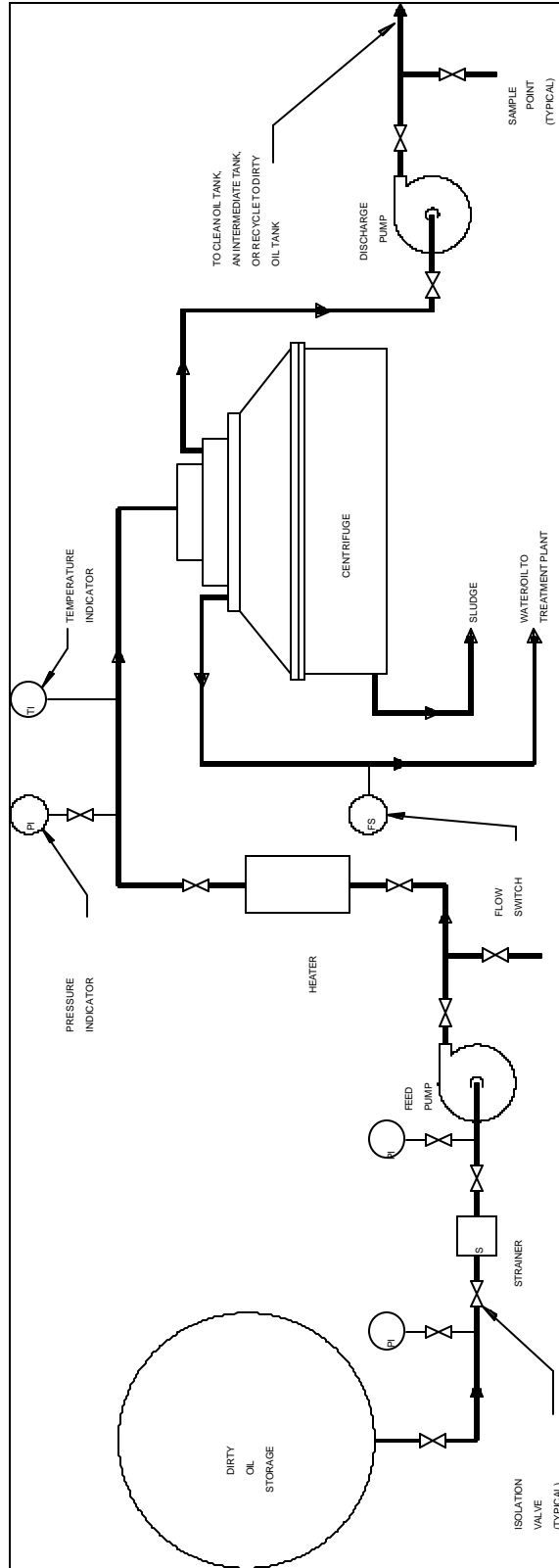

Figure 6-3. Lube oil purification system

(2) When the lube oil in a piece of equipment must be changed, the dirty lube oil may be returned to a main dirty lube oil tank. Depending on the size of the facility, there may be an intermediate dirty oil storage tank and a dirty oil return pump, as shown on figure 6-2. The dirty lube oil system may have many of the same type of devices and controls that were discussed as part of the clean lube oil system. For final disposal of dirty lube oil, the dirty lube oil tank will be equipped with a discharge. Depending on the tank location, oil may be discharged by gravity or by pumping. Final disposal may be delivery to a facility waste oil tank or to a waste disposal company, or oil recycling company tank truck or railroad tank car. Another discharge connection from the main dirty lube oil tank may be to a lube oil purification unit.

(3) Some dirty lube oil may be cleaned (purified) and reused as clean lube oil. Some lube oil users dirty the lube oil with contaminants that can be easily removed with commercially available centrifugal separation equipment. A typical centrifuge operation is shown on figure 6-3. Chemical analysis of the dirty lube oil determines whether the dirty lube oil can be cleaned and reused or is ready for final disposal.

*b. Diesel engine lube oil system.* Each diesel engine is equipped with a lubrication system that lubricates and cools various engine components when an engine operates. Depending on the service and size of the diesel engine, the lube oil system components may be part of the engine package and engine-mounted or mounted on the engine skid (typical of emergency service diesel engines), or may be stand-alone components (typical of large primary service diesel engines). The lube oil system components for diesel engines in either primary or emergency service generally have the same components and operate in a similar manner. A typical emergency service diesel engine lube oil system is shown on figure 6-4. A typical primary service diesel engine lube oil system is shown on figure 6-5.

(1) Monitoring and control of an engine lube oil system is by means of various pressure, temperature, and level monitoring gauges, instruments, and control valves. Typical diesel engine lube oil controls are shown on figures 6-4 and 6-5. Many of the instruments include switches that may prevent the engine from starting if the lube oil pressure, temperature, or flow does not meet some minimum requirement. They also may sound an alarm or shut the engine down if the oil pressure is too low, the oil temperature is too high, or the pressure drop across a filter is too high.

(2) Many diesel engines will have a lube oil heating system to maintain the lube oil near the normal lube oil temperature when the primary service diesel engine is in standby operation. The lube oil heating system may consist of a strainer, a circulating pump, and a heater. A typical primary service diesel engine standby operation lube oil heating system is shown on figure 6-6.

(3) The electric motor-driven prelube pump in an emergency service diesel engine lube oil system generally operates all the time when the diesel engine is not operating, but is in ready-to-operate standby service.

(4) The electric motor-driven prelube pump on a primary service diesel engine generally only operates for a short period of time before the diesel engine is started. Some older primary service diesel engines have hand-operated prelube pumps. Before starting an engine, the operator must use the hand-operated pump to pressurize the lube oil system. The prelube pump on primary service diesel engines may also be operated for a period of time when the engine is shut down to provide for controlled cooling of engine components.

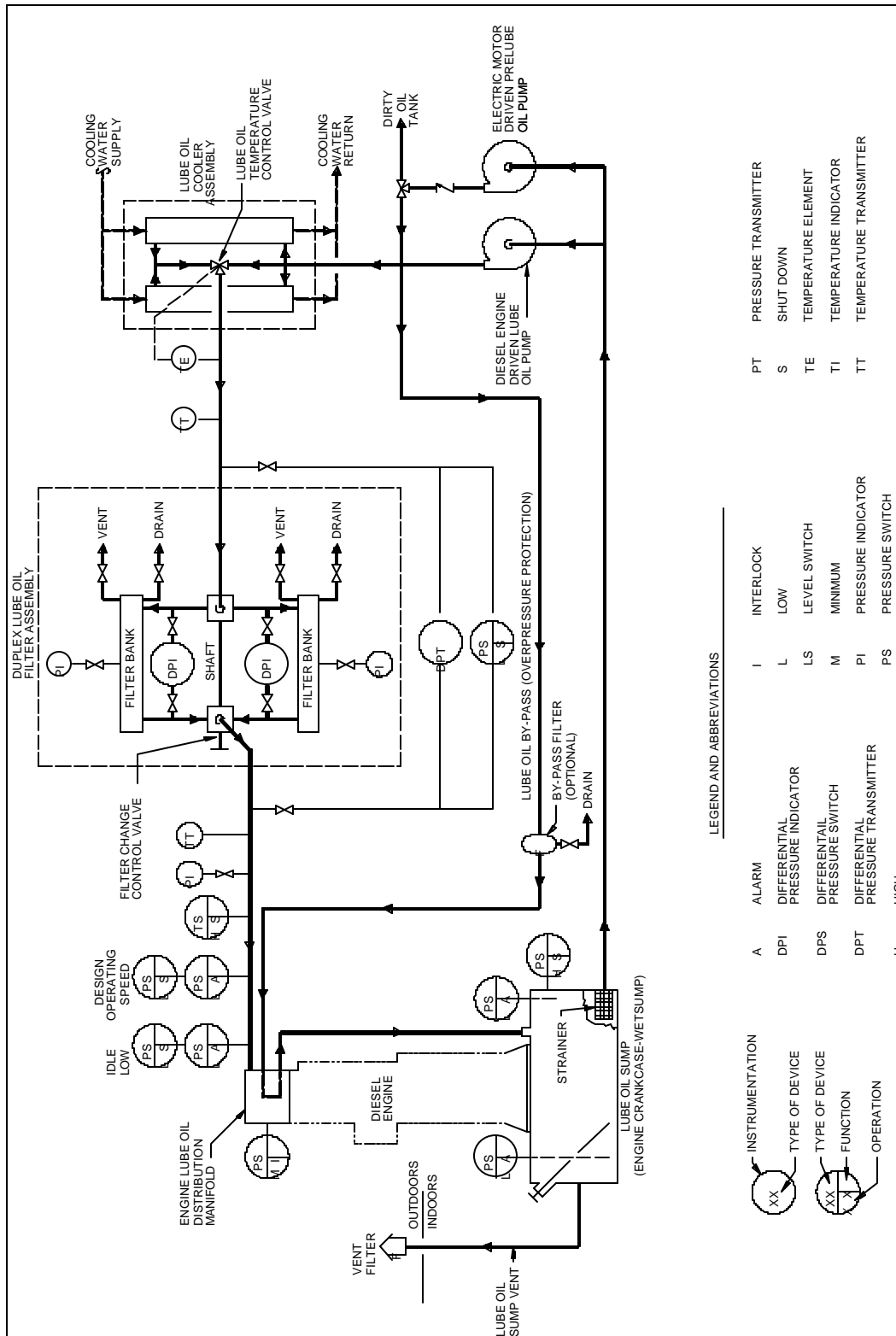

LEGEND AND ABBREVIATIONS

	INSTRUMENTATION	A	ALARM	I	INTERLOCK	PT	PRESSURE TRANSMITTER
	TYPE OF DEVICE	DPI	DIFFERENTIAL PRESSURE INDICATOR	L	LOW	S	SHUT DOWN
	TYPE OF DEVICE	DPS	DIFFERENTIAL PRESSURE SWITCH	LS	LEVEL SWITCH	TE	TEMPERATURE ELEMENT
	FUNCTION	DPT	DIFFERENTIAL PRESSURE TRANSMITTER	M	MINIMUM	TI	TEMPERATURE INDICATOR
	OPERATION	H	HIGH	PI	PRESSURE INDICATOR	TT	TEMPERATURE TRANSMITTER
				PS	PRESSURE SWITCH		

Figure 6-4. Emergency service diesel engine lube oil system

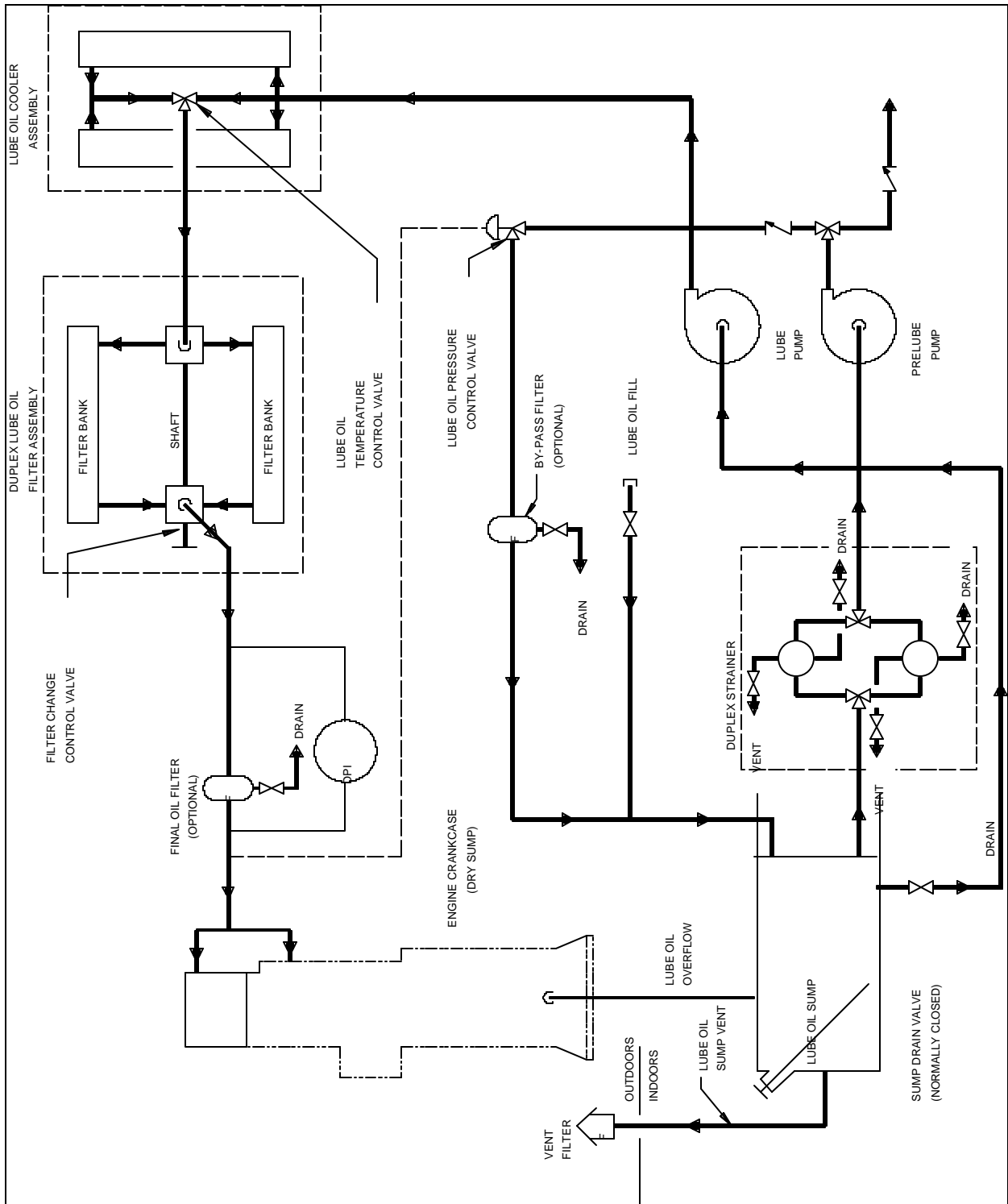

Figure 6-5. Primary service diesel engine lube oil system



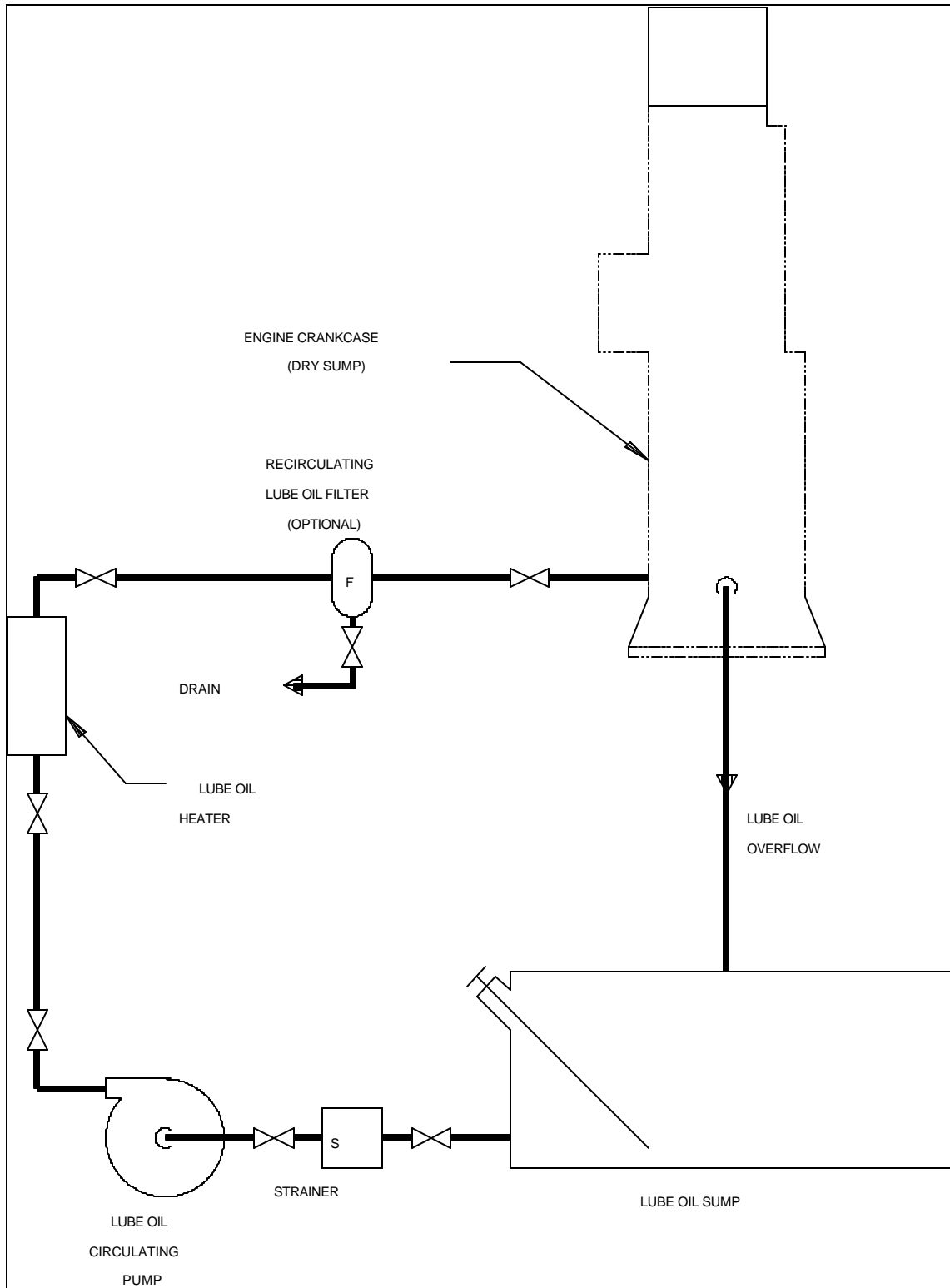

Figure 6-6. Diesel engine standby operation lube oil heating system

## 6-2. Lube oil system major components

The lube oil system is comprised of the following major components.

*a. Pumps.* Various types of pumps are utilized in lube oil systems.

(1) For a discussion of the types of pumps which may be used in lube oil systems for transferring lube oil throughout the facility, see chapter 5.

(2) The engine oil pump pulls oil from the lube oil sump and is the pressure pump supplying lubricant to the engine when the engine is operating. The main lube oil pump is usually mounted on the engine and is a positive displacement pump, gear-driven by the engine.

(3) The prelube pump is generally a close-coupled, self-priming, positive displacement pump of the rotary lobe or gear type. The prelube pump is driven by an electric motor. The prelube pump pulls oil from the lube oil sump and supplies lubricant to the engine when the engine is in standby operation.

*b. Storage tanks.* Storage tanks are generally fabricated from carbon steel plate with welded joints. All lube oil tanks should be fabricated and operated in accordance with the general requirements of National Fire Protection Association (NFPA) 30, Flammable and Combustible Liquids Code (1996), for flammable liquid storage. Most lube oil is stored in atmospheric storage tanks. Most storage atmospheric tanks are either the vertical or horizontal cylindrical type.

*c. Heat exchangers.* Heat exchangers are commonly used in both the lube oil cooler and lube oil heating subsystems.

(1) The lube oil cooler assembly generally uses shell-and-tube heat exchangers. Depending on the lube oil flow rate, a single heat exchanger may be used or two or more units may be used. When more than one heat exchanger unit is required, it is common to connect the heat exchangers in parallel. Lube oil is generally piped through the shell (outside the tubes), and the cooling fluid is piped through the tubes (inside the tubes). Some newer facilities may use, or may have replaced old shell-and-tube units with, plate type heat exchangers.

(2) The heat source may be steam (preferred for high capacity heating), hot oil, hot water, or low density electric (low flow applications) depending on the needs of other operations at the facility.

(a) Lube oil storage tank heaters are generally of the convection type. The tank heater should be designed for insertion into the storage tank through a manhole that does not exceed 24 inches diameter. Convection type heaters should have the capacity to raise the temperature of a full tank of lube oil by about 60°F in 24 hours.

(b) Lube oil in-line heaters are generally of the shell-and-tube type for liquid-to-liquid heat transfer or the electric bayonet type. For electric heaters, the heater should be designed so that the heating element can be removed without draining the heater shell.

*d. Strainers.* Strainers are used to remove coarse particulate matter that may damage rotating equipment.

*e. Filters.* Particulate filters are used to remove fine particulate from lube oils.

*f. Centrifuge.* The lube oil purification system centrifuge is utilized for purification (separation of liquids) and clarification (removal of solids). This unit is generally a high-speed centrifuge with a self-cleaning bowl. Centrifuge units are generally supplied as complete units. They include: differential pressure gauges; sight glass elements on the water discharge; a diaphragm-operated control valve in the main discharge with a flow-limiting pilot and a float-operated pilot to close the main valve if the water level in the sump rises above a set point; an automatic, float-controlled, diaphragm-operated water drain valve; a manual water drain valve; a head lifting device; and automatic air release devices.

*g. Engine lube oil temperature control valves.* Temperature control valves are used in engine cooling systems which use a lube oil bypass to maintain either a constant lube oil temperature at the engine lube oil outlet or a constant lube oil supply temperature. The most common engine lube oil temperature control valve is a self-contained, factory-set, thermostatic element-operated, sealed three-way valve unit. When installed to maintain a constant lube oil outlet temperature, the unit is referred to as a diverting valve. When installed to maintain a constant lube oil inlet temperature, the unit is referred to as a mixing valve. The valve is designed to maintain full lube oil flow through the engine cooling system. A thermostatic element in one of the valve ports controls a sliding valve assembly that controls the flow through that port. In the closed position, all of the flow is from the inlet port and out the other port. As the thermostatic element moves the sliding valve off the valve seat, a portion of the flow is from the inlet and through the thermostatically controlled port. At full lift, all of the flow is through the thermostatic port.

*h. Valves and piping.* This subsection presents an overview of the types of piping components and design and testing considerations related to facility lube oil distribution and dispensing piping systems. Information contained in this section applies to field-installed piping. Piping design, materials, fabrication, assembly, erection, inspection, and pressure tests for facility piping systems should be in accordance with American Society of Mechanical Engineers (ASME) 31.3, Process Piping. Inspection of modified piping installations should include radiographic or magnetic particle inspection of welds where applicable. New piping should also be hydrostatic tested. During testing, system components such as storage tanks, filters, centrifuges, or similar equipment that was not designed for the piping test pressure must be disconnected and protected against damage by overpressure.

(1) Valve bodies and bonnets should, as a minimum, be cast or forged carbon steel in accordance with American Society for Testing and Materials (ASTM) A 105, Standard Specification for Carbon Steel Forgings for Piping Applications (1998), for forged body valves and ASTM A 216, Standard Specification for Steel Castings, Carbon, Suitable for Fusion Welding, for High-Temperature Service (1998), Grade WBC, for cast body valves. Cast iron or bronze body valves are not suitable for lube oil service. The typical types of valves and valve trims used in lube oil service are as follows.

(a) Gate valves may be used for lube oil shutoff service where a slow closure is acceptable and where absolute bubbletight closure is not a critical consideration. Gate valves may be rising stem, outside stem and yoke (OS&Y), or double-disk type.

(b) Ball, butterfly, or non-lubricated plug valves are generally used where quick or frequent opening or closing is required. Synthetic seals or seating material in ball and butterfly valves should be teflon or viton. Butterfly valves shall be high-performance type with eccentric disk shaft and camming action for bubbletight shutoff.

(c) Double-seated plug or ball valves with an automatic body bleed between the seats should be used for separation of product services on tank shell connections and other locations critical to pressure testing of piping.

(d) Check valves are used in the lube oil system to prevent backflow through pumps, branch lines, meters, or other locations where runback or reverse flow must be avoided. Check valves may be of the swing disk, spring-loaded poppet, ball, or diaphragm-actuated types. Swing checks should be a soft-seated, non-slamming type with renewable seats and disks.

(e) Globe valves are used in lube oil systems at locations where manually controlling the flow rate is required. General use of globe valves should be avoided because of their high resistance to flow.

(f) Diaphragm type valves typically operate on the basis of pressure differential and are used for automatic or remote control of functions, such as flow control, pressure control, or level control. All diaphragm type valves should have teflon or viton packing, seals, and trim.

(2) Pipe used in lube oil systems is generally, as a minimum, carbon steel conforming to the requirements of ASTM A 106, Standard Specification for Seamless Carbon Steel Pipe for High-Temperature Service (1999), Grade B, seamless for pipe 1-1/2 inches in diameter and smaller and ASTM A 53, Standard Specification for Pipe, Steel, Black and Hot-Dipped, Zinc-Coated, Welded and Seamless (1999), Grade B, ERW for pipe 2 inches in diameter and larger. Pipe 1-1/2 inches in diameter and smaller should be Schedule 80 in accordance with ASME B36.10M, Welded and Seamless Wrought Steel Pipe (1996), and pipe 2 inches in diameter and larger should be Schedule 40.

## CHAPTER 7

### ENGINE INTAKE AND EXHAUST SYSTEMS

---

#### 7-1. Engine intake and exhaust system design features

The function of an engine intake and exhaust system is to deliver combustion air to the engine and dispose of the engine exhaust with as little impact as possible on engine performance. The air intake system may consist of ducts, air filter elements, silencers, etc., as required to lead the combustion air to the engine manifold or blower (turbocharger) air inlet connection. In addition to supplying combustion air to the engine, another important function of the air intake system is to condition the air (usually just particulate removal) to protect engine parts from airborne impurities (dirt and other particulate matter). Air intake systems may also have devices to reduce noise transmitted from the engines. Ducted air intake systems permit the engine to be installed at a location remote from the supply of combustion air. A basic exhaust system consists of an exhaust gas discharge duct, with components to accommodate expansion of the duct, and an exhaust gas silencer (muffler). Some exhaust systems may include components to use the hot exhaust gas to provide the heat for some other process or operation (waste heat recovery), such as fuel oil heating, hot water production, steam generation, etc. When an engine operates within a facility that is protected against attack (blast-protected), the intake and exhaust system must include blast protection features. Maintaining the filter elements, keeping the air intake and exhaust gas discharge points free from obstructions, (such as severely dented or crushed duct sections) that restrict the free flow of combustion air to the engine and exhaust gas from the engine is very important.

*a. Basic air intake and exhaust gas systems.* A typical basic air intake and exhaust system has air entering the system through an intake air filter. Depending on the size of the engine, the design use of the engine, and the location where the engine is to be used, the air intake filter may range in size from a small replaceable paper filter element to a large filter bank with numerous filter elements. From the intake filter, the air may pass through a separate air intake silencer before reaching the engine combustion air inlet connection. On many engines, the air intake filter may also provide the necessary air intake silencing eliminating the need for a separate air intake silencer. The basic air intake system described might be used on many different kinds of engines (diesel, gaseous fuel, and gasoline) and compressors.

(1) On the normally aspirated diesel engine, the combustion air passes through an air shutoff valve to the engine combustion air distribution manifold and then to individual engine cylinders. On the turbocharged (or air-scavenged) engine, a fan, blower, or compressor device provides compressed air (more pounds of air in the same space) through an air shutoff valve and aftercooler to the engine combustion air distribution manifold. Depending on the engine size and design, the turbocharger device may be standalone (not driven by the engine) or driven by the engine (engine-driven). An engine-driven turbocharger may be directly driven by the engine through a gear or belt drive by the flow of exhaust gases through a turbine section. At the same time the turbocharger (or air scavenger) increases the pressure of the combustion air supplied to the engine, the temperature of the air is also increased. Since the diesel engine is a compression-ignition cycle, an aftercooler may be used on diesel engines to reduce the air temperature low enough to prevent early ignition of the air-fuel mixture.

(2) The operation of a basic air intake system is usually monitored by pressure gauges at the inlet of the engine air intake manifold (on the inlet side of any turbocharger or air scavenger device). As the air intake filter elements become dirty, the vacuum slowly increases. When the vacuum increases beyond an engine manufacturer-specified value, the intake air filter elements may need to be cleaned or replaced. Most systems will have temperature gauges to monitor the exhaust gas temperatures. Systems with

turbocharger or air scavenger devices may also have pressure gauges to monitor the combustion air pressure at the discharge of the device. Systems with aftercoolers may also have pressure gauges to monitor the combustion air pressure at the discharge of the aftercooler and temperature indicators to monitor the combustion air temperature at the inlet and outlet of the aftercooler.

*b. Dusty environment air intake system.* Engines used in dusty environments may need air intake filters with more face area or, depending on the dust size and frequency of dusty conditions, a series of filters may be required to protect the engine. In areas where the amount of dust in the air varies with weather, the filter system may need to be capable of responding to varying dust concentrations. A common dusty environment air intake and exhaust system is where the engine is installed in a building. Combustion air for the engine is pulled from inside the building through an intake air filter assembly, and the exhaust gas is ducted to outside the building and discharged through an engine exhaust silencer installed outside. The roll filter bank, by advancing either on a timed cycle or when the pressure drop across the filter reaches a preset value, responds to variable dust conditions. The extended filter surface bank (deep cell filter) provides a lot of total filter area compared to the face area of the filter frame to minimize how often filters have to be changed.

*c. Blast-protected air intake and exhaust systems.* Blast protection can mean different things depending on the type of facility. For this discussion, a blast-protected facility refers to a facility that is designed to withstand a specific blast effect and continue in operation throughout the design level attack.

(1) Figure 7-1 shows a blast-protected air intake system. The engine (not shown on the figure) is located deep within the facility and pulls combustion air from inside the facility through an engine intake air filter. In this example, the air intake is not only providing combustion air to the engines, but is also providing air to occupied spaces within the facility. The example blast-protected intake system utilizes an intake air fan to draw air into the facility. In facilities using intake air fans, there is usually a standby fan installed so that fans can be removed from service for maintenance and so a spare fan is available in the event an in-use fan fails. The example blast-protected air intake system is installed inside a blast-resistant structure. Air enters the structure through an array of blast valve assemblies that are built into the blast-resistant structure. See chapter 32 for a detailed description of blast valves and blast valve operation and maintenance.

(a) In addition to the roll filter assembly and the deep cell filter bank, the example blast-protected air intake system includes a prefilter element and a CBR (chemical-biological-radiological) filter bank. The prefilter is provided to handle short-term, very high dust and debris concentrations that may occur during an attack. Many systems allow intake air to bypass the prefilter during periods when the blast protection system is not in the blast mode of operation. If the blast protection system is in operation, the prefilter may also be bypassed when the filter elements become plugged.

(b) The CBR filter bank removes chemical and biological agents and radioactive particles from the intake air. As with the prefilter, many blast-protected air intake systems allow intake air to bypass the CBR filter elements when the blast protection system is not in the blast mode of operation. While this prevents the performance of the CBR filters from being impaired by a buildup of dirt, the reactive filter media deteriorates from exposure to air and requires replacement on a regular basis even if the filter bank has not been in service.

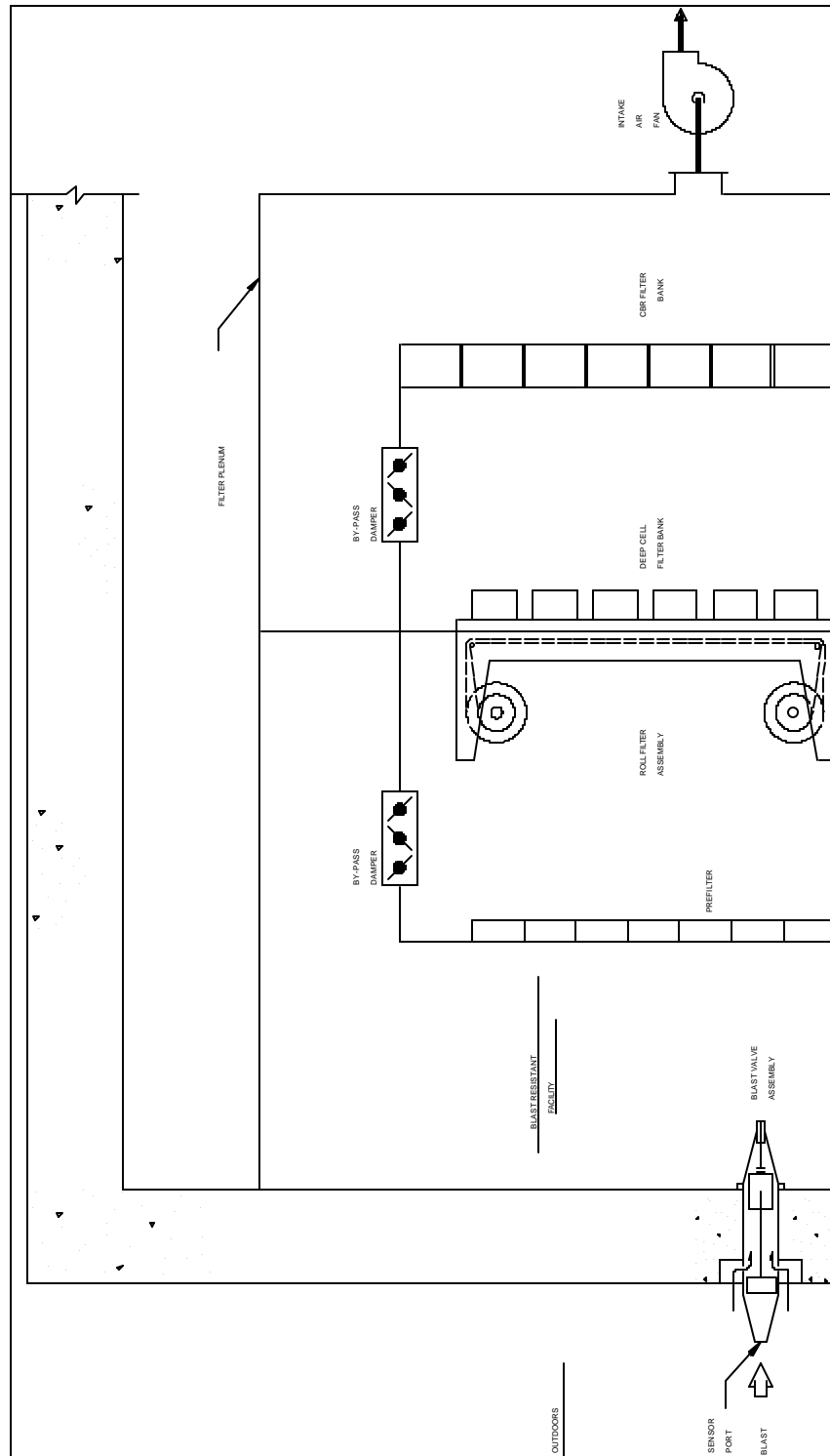

Figure 7-1. Blast-protected air intake system

(2) Figures 7-2 and 7-3 show blast-protected engine exhaust systems. On figure 7-2, the engine exhaust gas is discharged into a mixing chamber and the mixing chamber discharges to the outdoors through an array of blast valve assemblies (only one valve is shown on each figure). There are two features in this blast-protected engine exhaust system not usually found on engine exhaust systems in ordinary facilities, an exhaust cooling system and an exhaust isolation system.

(a) During normal operation, the engine exhaust is cooled to prevent damage to the blast valve assembly. During periods when the blast-protected facility is not in the blast mode of operation, other systems (such as cooling towers) can provide exhaust cooling by mixing with the engine exhaust. When the facility is in the blast mode of operation and many normal operations are curtailed, a water spray system similar to the system shown on figure 7-2 may be used.

(b) Another blast-protected exhaust system option is shown on figure 7-3. In this example, each engine exhaust duct has a high-temperature blast valve in the exhaust duct. When blast sensors trip the valve, an exhaust system relief valve (poppet valve) diverts the exhaust to an unoccupied space within the blast-protected facility. The exhaust systems on units not in operation are potential points of contaminant (exhaust gases from operating units, chemical or biological agents, radioactive particles, etc.) entry into protected spaces. Therefore, exhaust systems in blast-protected facilities may include valves (or dampers) in the exhaust duct system that automatically close when a unit is not in operation and the facility is in the blast mode of operation. The example blast-protected exhaust system shown on figure 7-2 has two isolation valves in series with an air purge in between to prevent backflow through the exhaust system of an out-of-service unit.

## 7-2. Engine intake and exhaust system major components

Descriptions of major system components for engine air intake and exhaust systems will be limited to components directly related to the operation of the engine. These components include combustion air particulate removal filters, intake air silencers, exhaust silencers, and air intake and exhaust duct materials of construction and duct system components. Items which impact the operation of the air intake and exhaust systems that are part of other systems (such as blast protection, compressed air, and industrial water) are described in other chapters of this manual.

*a. Combustion air particulate removal filters.* Common combustion air particulate removal filters are either wet type or dry type. Within the filter types, the filter elements may be either permanent (clean and reuse) or disposable.

(1) Three common wet type filters used to remove particulate matter from combustion air include the following.

(a) Viscous impingement filters are packed with fine strands of wire coated with oil. Air passing through the filter element impinges on the wires, and the oil coating traps the dust particles.

(b) Oil bath filters have a reservoir of oil. The filter housing is arranged to sweep the surface of the oil bath with the combustion air passing through the filter that agitates the bath. The oil coats and traps the particles, and the oil-coated particles collect in the oil reservoir.



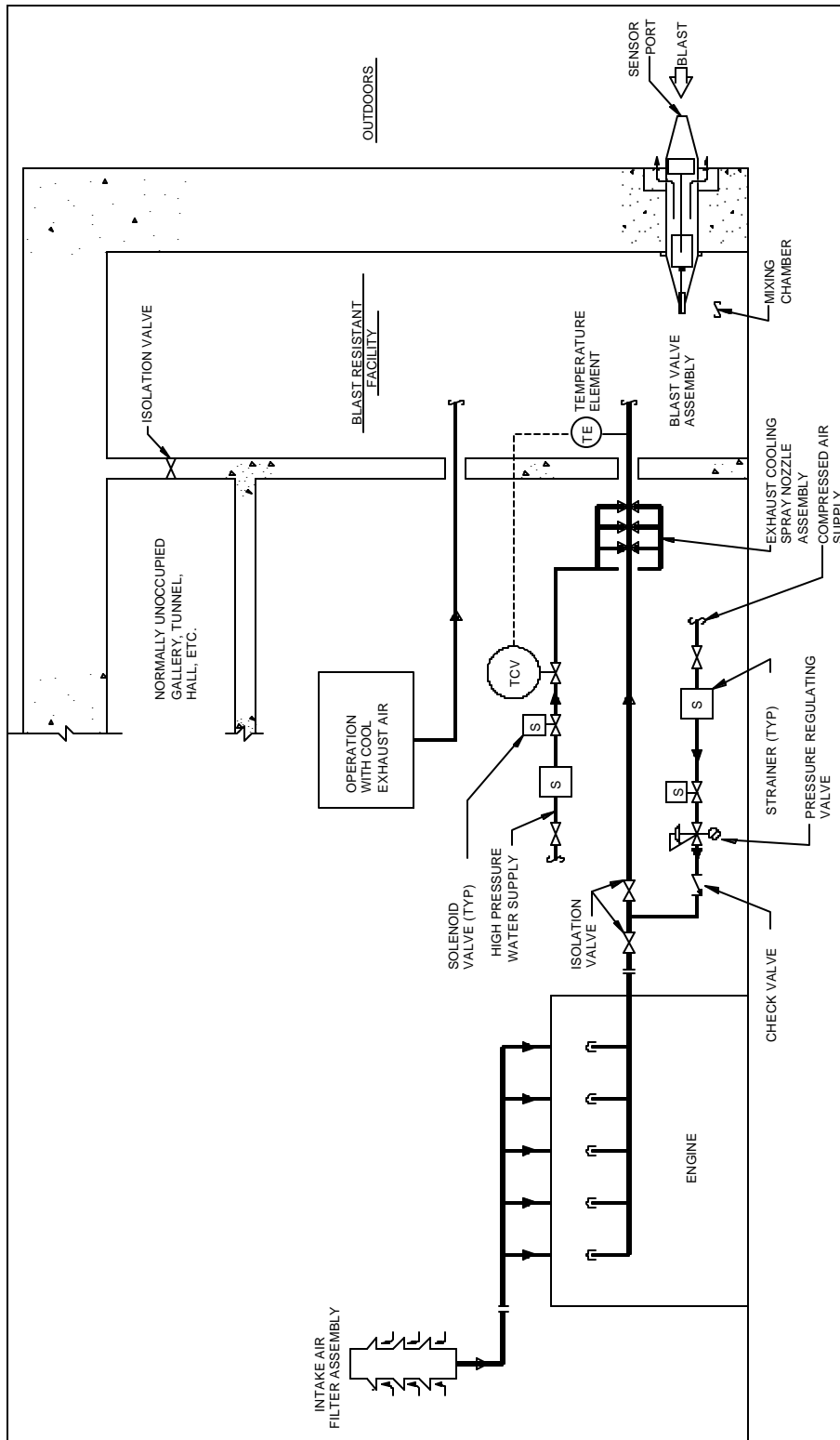

Figure 7-2. Blast-protected engine exhaust system

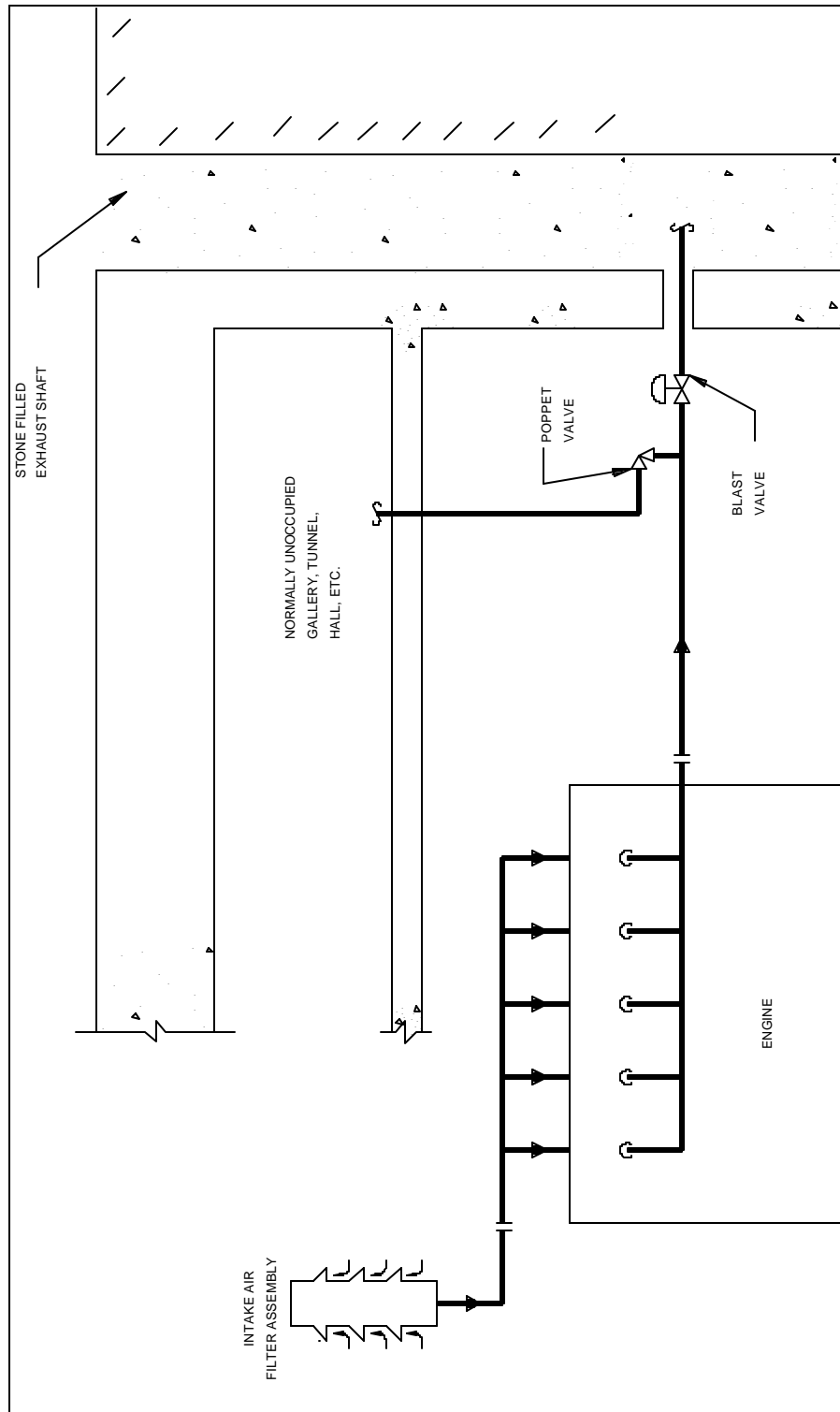

Figure 7-3. Blast-protected exhaust system

(c) Traveling screen filters are a combination of the viscous impingement and oil bath filters. A moving wire screen is continuously passed through an oil bath to be coated with oil. Air passing through impinges on the wire screen, and the oil coating traps the dust particles. As the wire screen passes through the oil bath, the dust particles are washed off the screen and collect in the oil reservoir. Most wet type filter elements are considered to be permanent elements.

(2) Many materials can be used to make filter media for dry type combustion air filters. Typical materials are fiberglass, polyester, cotton (a form of cellulose), and paper (also a form of cellulose). Common combustion air filter media types using these materials are woven, felted, pad, and mesh (or blanket). Most common combustion air dry type filter elements are replaceable elements. However, some units with a prefilter section designed to remove small volumes of relatively large diameter particles may use permanent filter elements.

*b. Intake air and exhaust silencers.* Common silencer units reduce (attenuate) the noise transmitted through the system by decreasing the velocity of the gas stream and absorbing the sound or by canceling sound waves with other sound waves from the same source. Most engine silencer units (intake and exhaust) are installed in-line with the duct system. Silencer units are usually several times larger in diameter than the duct. Silencer units may be a perforated flow-through tube which allows noise to escape into side chambers where the noise is absorbed. Silencer units may also be a baffled unit where changes in direction first separate and then recombine the gas stream causing sound waves to cancel each other. Common silencer units used with internal combustion engines have an internal volume equal to six to eight times the displacement of the engine. Noise transmitted through most combustion air intake systems has much less energy than noise transmitted through the exhaust gas system. The reduced noise energy in the intake system can be abated by the intake air filter media acting as a baffle and a noise absorbing mass. Therefore, most combustion air intake systems do not have a separate silencer unit. Some engines with turbocharger units that are driven by a turbine section turned by the exhaust gases may not require an exhaust silencer.

*c. Intake and exhaust duct and duct components.* Many materials may be used to fabricate the duct system and duct system components. One common material is carbon steel and another is stainless steel. The material selection is usually an economic decision during the initial design that considers the cost of the initial installation and future maintenance costs. Without careful study, repairs to existing systems should use the same materials and material thickness used in the original installation.

(1) The most common method for moving gases under moderate pressures is by means of some type of fan. There are two broad categories of fans: axial flow and centrifugal. Axial fans use propellers to move the air and are generally classed into three subtypes: propeller, tube axial, and vane axial. Centrifugal fans use fan wheels to move the air and are also classed into three subtypes according to the basic characteristics of the wheel used: forward curved, backward curved, and radial.

(2) A common expansion joint used to isolate rotating equipment from connected loads and to control thermal movements is a bellows type joint. These joints can accommodate axial, lateral, and angular motion, or limited combinations of each motion. For a specific set of operating conditions and a specific material of construction, the wall thickness of the expansion joint section, the outside diameter of the bellows, and the number of convolutions determine the amount of movement the expansion joint can accommodate.

(a) Bellows type joints can be fabricated from a wide variety of materials. Metal expansion joints are typically used in diesel engine air intake and exhaust gas systems. A common material of construction for these expansion joints is stainless steel. Expansion joints should be sized and

constructed in accordance with the Standards of the Expansion Joint Manufacturers Association, the appropriate sections of the American National Standards Institute (ANSI) Power Piping Codes, and the appropriate sections of the American Society of Mechanical Engineers (ASME) Boiler and Pressure Vessel Codes.

(b) Expansion joint failures are common maintenance problems. Common failure modes and the cause of the failures are shown in table 7-1. When faced with an expansion joint failure, maintenance personnel may make repairs to keep critical systems in operation. However, most field repairs change the response characteristics of the system that may cause problems in other parts of the system (e.g., engine manifold cracking, duct hanger deformation or failures, facility structural member deformation or failures, etc.). Repairs to expansion joints should be considered temporary, and arrangements should be made to replace the expansion joint as soon as possible. Except for the failure associated with chlorides leaching from insulating materials, all of the listed failure modes are the result of the expansion joint design not conforming to existing conditions. When the expansion joint is replaced, the design of the new expansion joint should reflect the current operating conditions. However, if there is a significant change in response characteristics of the replacement expansion joint relative to the original expansion joint, other modifications in the duct system may be required. This makes evaluating expansion joint problems and maintaining expansion joints a maintenance and facility engineering responsibility. If expansion joints fail because the actual movements to be accommodated by the joints exceed the capacity of the joints, the system needs to be reanalyzed and appropriate modifications need to be designed.

Table 7-1. Typical bellows material failures

<i>Failure Mode</i>	<i>Most Frequent Cause(s)</i>
Stress Corrosion	Chlorides, caustic, high temperature sulfurous gas acting on nickel alloys, leaching of chlorides from insulation.
Fatigue	Unanticipated vibration, unanticipated temperature changes.
Carbide Precipitation	Use of unstabilized materials at high temperatures.
Squirm and Burst	Over pressurization.

(3) Butterfly or slide gate type valves (or dampers) are commonly used to provide isolation in blast-protected exhaust gas systems. Butterfly valves should have an offset operating shaft design so that the disk contacts a continuous disk-sealing surface. While a variety of materials may be used in the valve body, valve trim components are typically stainless steel or materials with similar heat- and corrosion-resisting properties.

## CHAPTER 8

# COOLING SYSTEMS

---

### 8-1. Cooling system design features

This chapter presents an overview of diesel engine cooling systems. Diesel engines are heat-generating sources cooled by circulating a water-based coolant through a water jacket which is part of the equipment.

The coolant is circulated through piping to a device to remove the heat added to the coolant by the engine and then back to the engine. Typical components associated with the cooling loop serving an engine are pumps, air separators, coolant expansion (or surge) tanks, temperature control valves, temperature switches, temperature and pressure indicators, and the coolant heat removal device.

*a. General.* Cooling systems are either closed or open. In closed systems, the system is designed to prevent significant losses from the system so the same coolant is used over and over. The quality of the coolant is easier and less costly to maintain in a closed system. Open systems either waste a coolant (use once and discharge to a drain) or re-circulate the coolant through systems that cool the coolant by evaporation, resulting in a buildup of impurities in the coolant stream. See figures 8-1, -2, and -3.

(1) Because of the need to carefully control coolant chemistry to prevent fouling of heat transfer surfaces and the need to closely control engine temperatures, closed cooling systems are generally used to cool diesel engines. The closed engine cooling system may also provide cooling for other components supporting the operation of the diesel engine, such as the lube oil cooler and the combustion air after-cooler on turbo-charged engines. Depending on the cooling needs of each device associated with the engine, all the devices may be cooled by a single-loop system, or multiple loops may be required.

(2) In an open system, water is re-circulated through an air contact cooling system, such as a cooling tower, cooling pond, or spray pond. Because of maintenance concerns relating to water quality, open cooling systems are generally not used on land-based diesel engines (or similar equipment), except as short-term emergency backup to a closed system.

(a) Although open cooling systems are usually not used to provide direct cooling to devices like diesel engines, re-circulating cooling water systems using cooling towers, cooling ponds, and spray ponds may be an important part of the overall cooling system for a facility. A large facility may have a lot of equipment that is water-cooled. The quantity of water required by each water-cooled device may not be significant, but the total quantity of cooling water required adds up to a large water bill or cannot be provided by the resources available to the site. And even if resources are available, some blast-protected facilities must disconnect from outside resources when in the blast mode of operation.

(b) Common devices used to remove heat from cooling water and supply re-circulating systems are cooling ponds (or open reservoirs), spray ponds, and cooling towers. The primary heat transfer mechanism for these devices is evaporation. When water evaporates, most of the impurities in the water are left behind that increases the impurities in the re-circulating water. These impurities can form scale on heat exchanger heat transfer surfaces, the walls of water distribution and return piping, and cooling tower surfaces, and will require maintenance to be performed to remove (or at least significantly

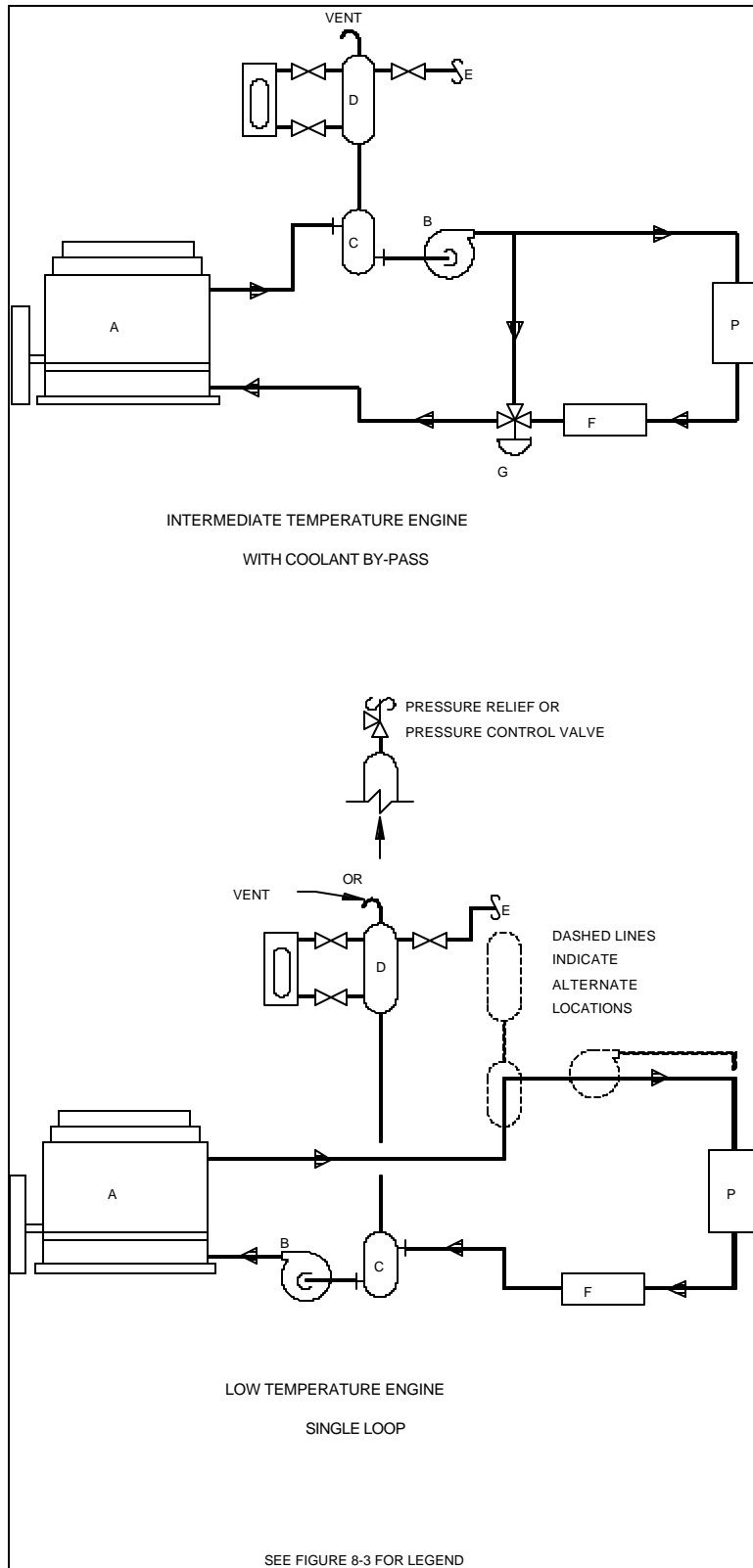

Figure 8-1. Examples of engine cooling systems(1)

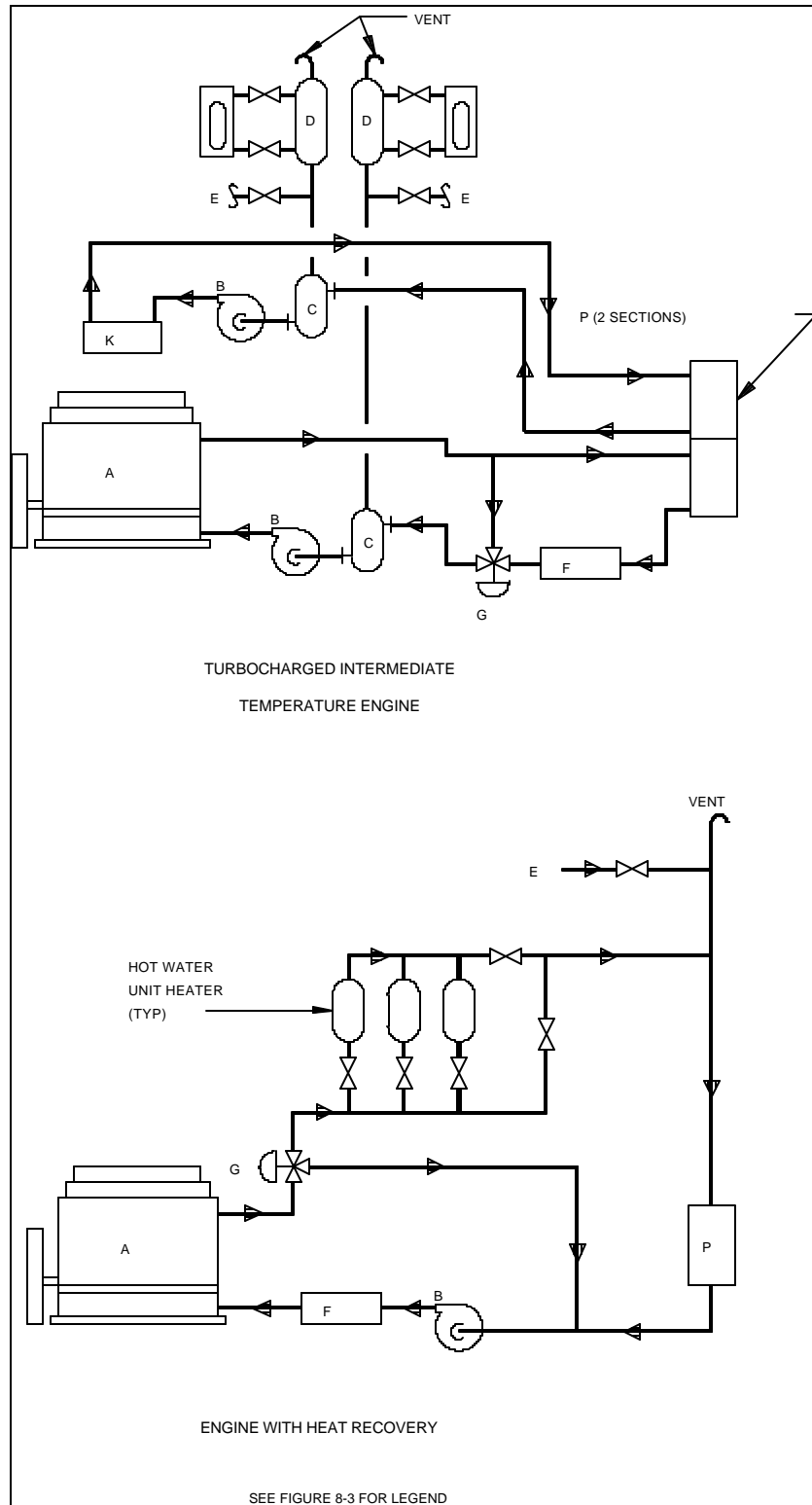

Figure 8-2. Examples of engine cooling systems(2)

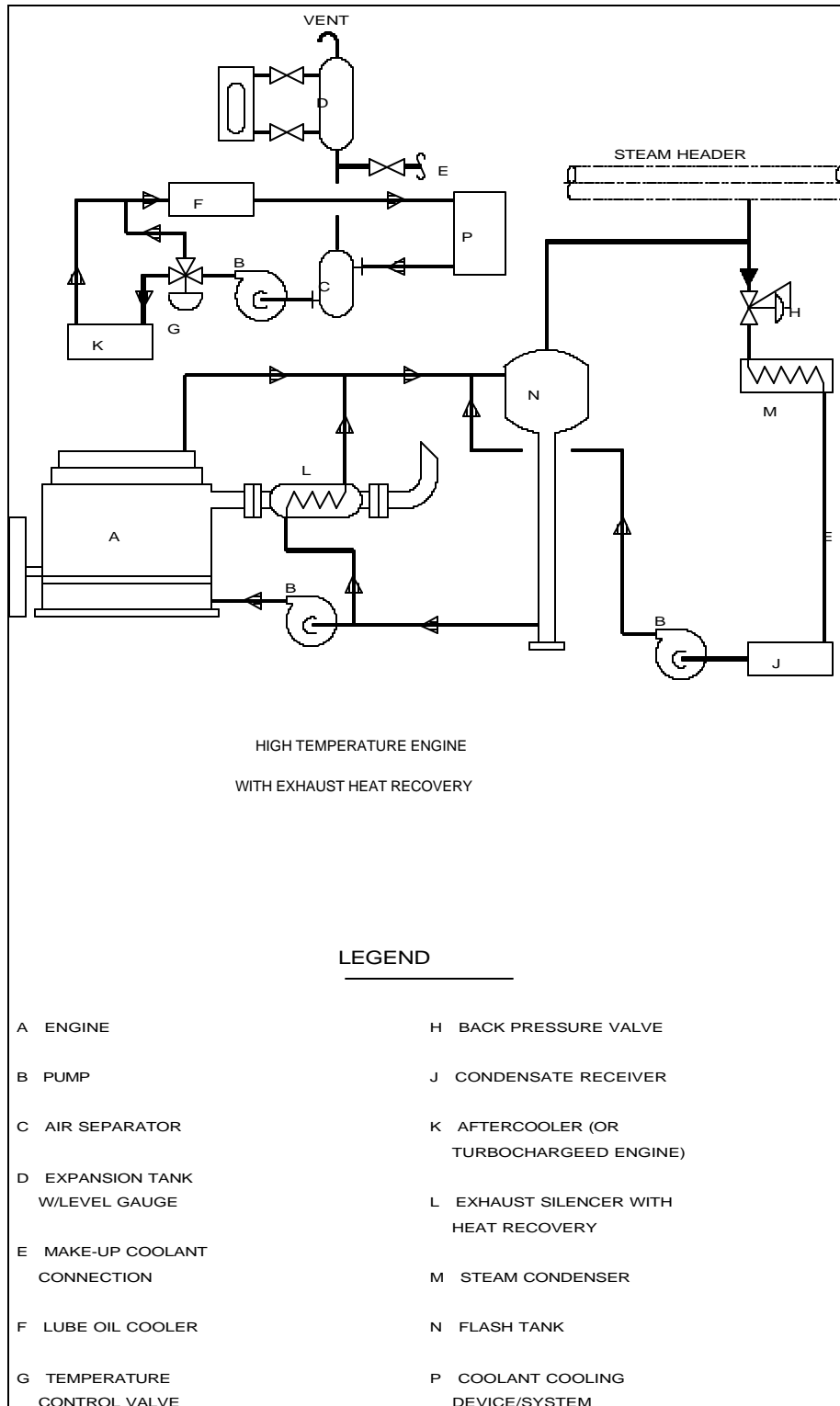

Figure 8-3. Examples of engine cooling systems(3)



reduce) the built-up scale. Chemical treatment of and blowdown from open re-circulating water systems are tools for reducing the build up of contaminants.

*b. Typical primary service diesel engine cooling system.* A typical engine cooling system for a large stationary, primary service, turbo-charged diesel engine is shown on figure 8-4. The cooling system consists of three cooling loops: a loop for the engine, a loop for the lube oil cooler, and a loop for the combustion air after-cooler. Heat is removed from the closed engine cooling system in the jacket water heat exchanger that is a liquid-to-liquid heat exchanger. The cooling water supply for the jacket water heat exchanger is a closed re-circulating cooling water system using a cooling tower. The cooling water supply for the after-cooler is also from the cooling tower system, while the cooling water supply for the lube oil cooler is from an industrial water re-circulating system that uses an open cooling reservoir.

(1) Hot coolant from the engine is piped to a temperature control valve (thermostat). The temperature control valve modulates the coolant flow between a branch that flows through the jacket water heat exchanger and a branch that bypasses the heat exchanger. After cooling, the total coolant stream enters an air separator unit. (Many cooling systems do not use an air separator unit.) The air separator is designed to separate gas bubbles from the coolant stream so the bubbles can be vented from the system. The coolant is then piped to the inlet of an engine-driven coolant pump that circulates water through the engine cooling water jacket. The expansion tank which, in the example system, is connected into the system through the air separator unit serves three equally important functions. The expansion tank provides space for coolant expansion, provides space for entrained gases to be removed from the system, and provides a static head which controls coolant flashing to steam in the system operating near the boiling point and prevents cavitation in the coolant circulating pump.

(2) The typical engine cooling system is equipped with a "keep warm" system. The keep warm system operates when the engine is not operating, but is in the standby ready to start mode. The keep warm system uses an electric motor-driven circulating pump to circulate jacket cooling water through a heater unit (usually an electric immersion heater) and then into the engine water jacket. The immersion heater heats the coolant to a temperature near the design coolant temperature for the engine. This minimizes startup wear on the engine and prolongs engine life. Maintaining the coolant, and hence the engine, near operating temperature also helps ensure that the engine will start.

(3) In the typical primary service diesel engine cooling system, the cooling water supply to the jacket water heat exchanger and lube oil cooler is either on or off. Temperature regulation of the engine coolant and lube oil temperatures is by bypass temperature control valves within the engine and lube oil cooling systems. The after-cooler cooling water supply also contains an on-off valve, but the temperature of the combustion air is regulated by a bypass valve in the cooling water piping at the after-cooler. When the engine receives a start signal, the engine controls open the on-off valves in the cooling waterlines. When the flow switches in the discharge lines indicate that cooling water flow has been established, the engine is allowed to start.

(4) In the typical primary service diesel engine cooling system, a number of pressure and temperature indicators are shown throughout the system. Readouts from these devices are important measures of how the system is operating. The readout units of these devices are usually mounted on the local control panel mounted at the diesel engine. The two main control devices for the engine cooling system are the two temperature indicators with output switches that either alarm on high engine coolant temperature or shut down the engine because of high engine coolant temperature. The alarm set point is usually set lower than the shutdown set point to permit the operator to investigate and correct the problem or start a standby engine before a high-temperature shutdown occurs.

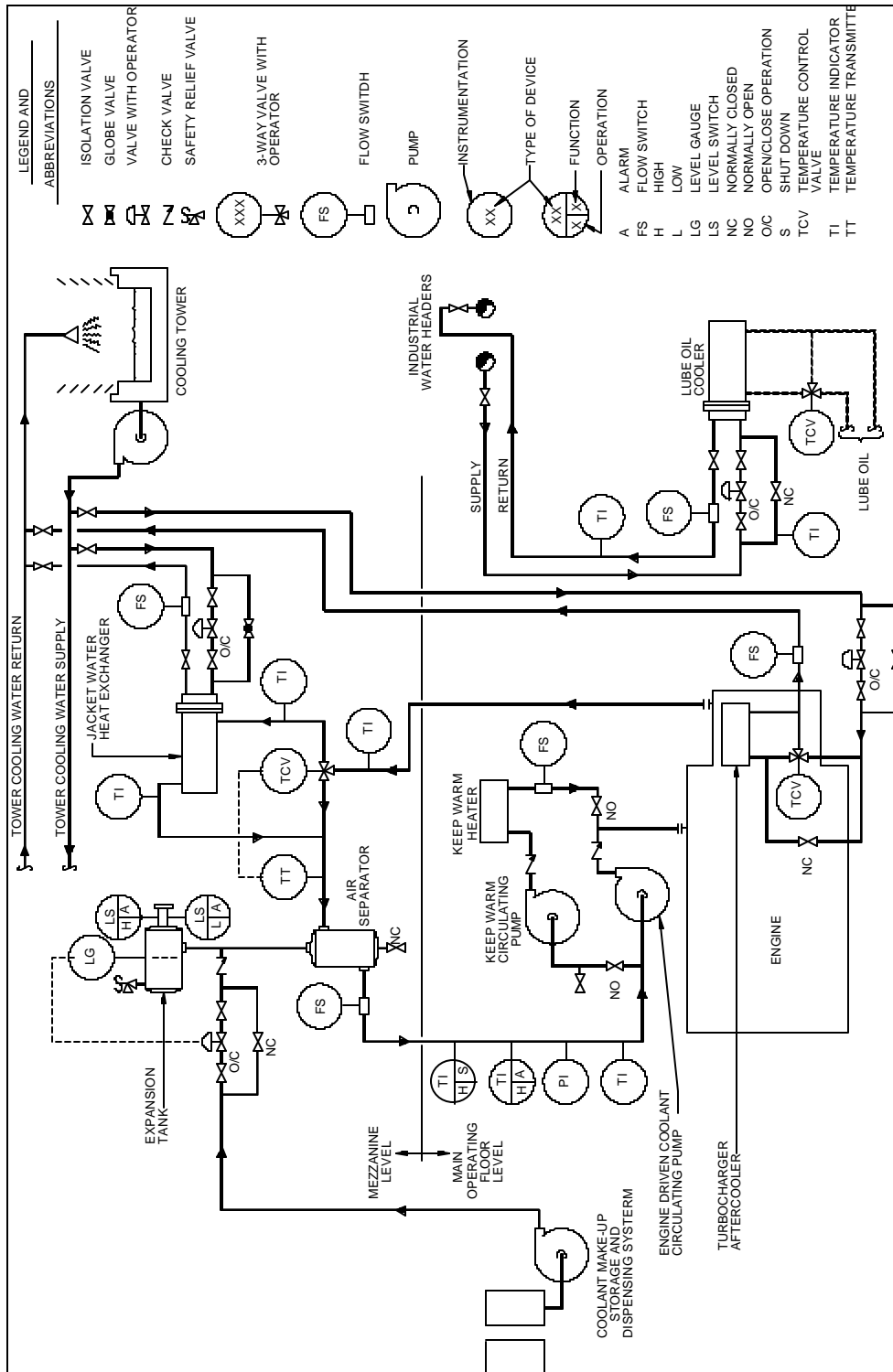

Figure 8-4. Typical primary service diesel engine cooling system

*c. Typical radiator diesel engine cooling system.* A typical stand-alone engine cooling system for a turbo-charged diesel engine is shown on figure 8-5. The cooling system consists of two cooling loops: a loop for the engine, and a loop for the lube oil cooler and combustion air after-cooler. Heat is removed from the closed engine cooling system in the jacket water radiator and the lube oil/after-cooler radiator which are liquid-to-air heat exchangers. The use of radiators with fan motors powered from the engine electrical system makes the engine cooling system independent of other facility systems and is typical of cooling systems for emergency service diesel engines. However, radiator cooling systems are also used in many primary service diesel engine installations where the radiator fan motors may be powered by the engine electrical systems or driven by an electric motor powered from the facility electrical distribution system.

*d. Coolant makeup storage and dispensing systems.* Most facilities with diesel engines have a coolant makeup storage and dispensing system. In large facilities, one system can usually serve all of the engines. At a minimum, the system will consist of a tank for preparing and storing large quantities of engine coolant with a pump and distribution piping to dispensing points near the makeup coolant fill points on equipment. Most systems are directly connected to the makeup coolant fill points. Most systems also include storage so that coolant drained from an engine during maintenance can be reused. In some systems with used coolant storage, there is either a separate coolant drain pump or the coolant distribution and drain piping is connected into a manifold that allows the makeup coolant dispensing pump to serve as both a dispensing and drain pump.

*e. Coolant quality.* Water treatment is critical to the operation of the engine cooling systems. It is important that a coolant quality monitoring and treatment program for a facility be developed and followed. Because of the wide variation in water supplies available and the likelihood of seasonal variations within a single source, no single coolant treatment program will work at every facility. Each facility requires a program tailored to the equipment used in the facility and the quality of the available water supply. A minimum water treatment program must provide for control of coolant quality parameters as follows.

(1) In outdoor installations, engine operations that may be shut down in cold weather must be protected against freezing.

(2) Only water with a hardness value of 0 (zero) should be used to make engine coolant.

(3) The pH value of the coolant solution should be between 8.0 and 9.5.

(4) The total solids concentration of the coolant should not exceed 3,500 parts per million.

(5) The oxygen content of the coolant should be maintained at a value of 0 (zero) by the addition of oxygen scavenging compounds, or the metal surfaces of the engine need to be protected against corrosion by the addition of corrosion inhibiting compounds.

*f. Typical cooling tower system.* A typical cooling tower (evaporative cooler, spray cooler, etc.) is shown on figure 8-6. Tower re-circulating cooling water flows from the pan section through a strainer built into the pan section into the spray (tower circulating) pump. The spray pump provides water to the spray header (or as a circulating pump discharges water into an open channel water distribution header). The downward flow of water in the cooling tower flows over the outside surface of the cooling coil. The evaporation of tower cooling water absorbs heat transferred through the cooling coil tube wall from the facility re-circulating cooling water stream.

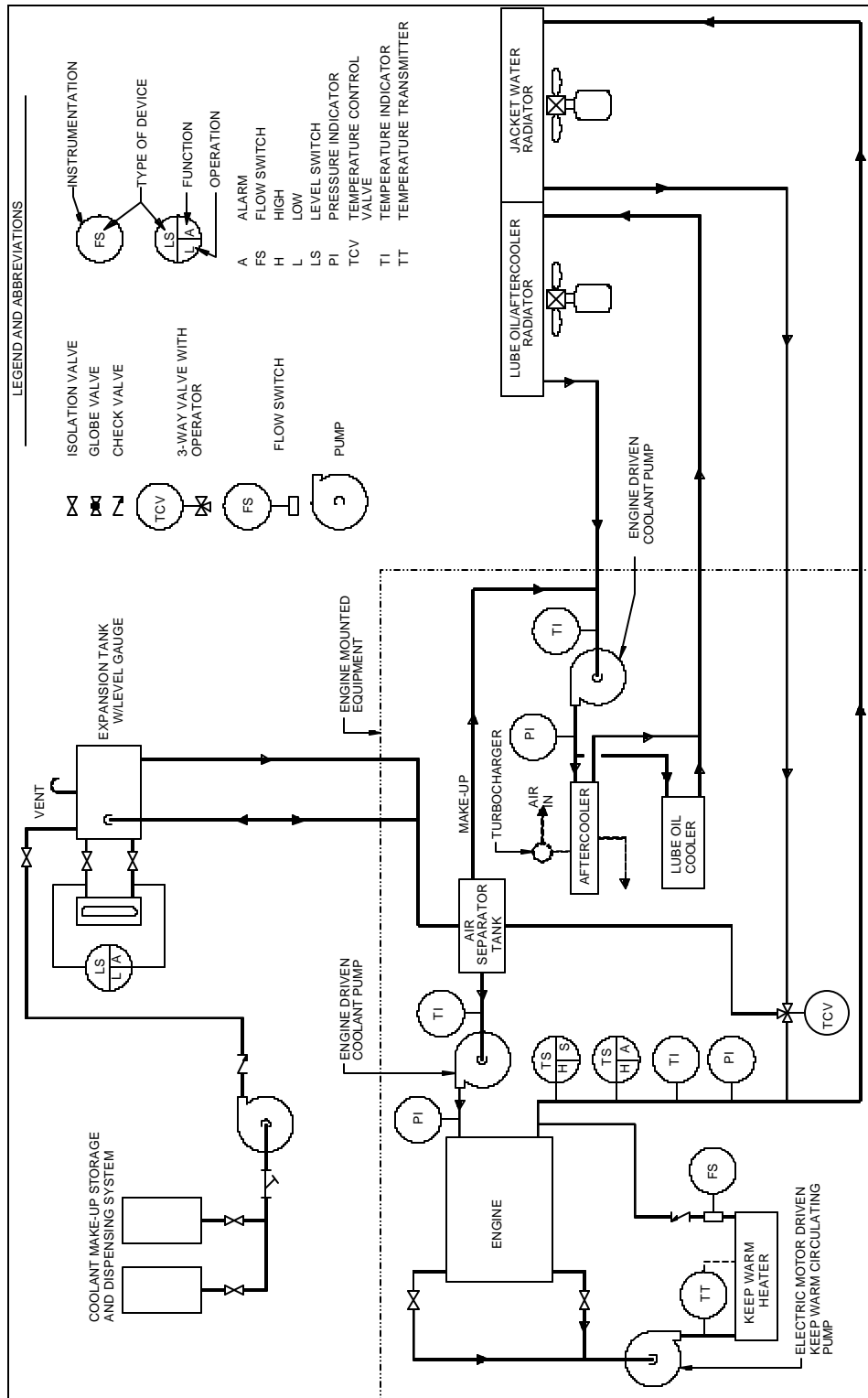

Figure 8-5. Typical radiator diesel engine cooling system

(1) As water evaporates, impurities are left behind. The quality of the tower cooling water may be controlled by discharging (blowing down) a portion of the tower water and adding fresh water and chemical treatment. Most towers have a blowdown valve located in the discharge piping of the spray pump. While some large towers may have water quality sensing equipment that controls the operation of the blowdown valve, most towers have a manual valve. A manual blowdown valve is usually adjusted to discharge water at a rate equal to the evaporation rate when the tower is operating at design conditions. Water is added to the pan section to maintain a constant level through a makeup water control valve. Most towers utilize float-operated makeup water control valves.

(2) Most cooling tower designs use fans to circulate air through the cooling tower. On many cooling tower units, the fans are integral with the unit. However, it is not uncommon for the fan to be a separate installation connected to the cooling tower by a duct system. Several cooling tower fan arrangements are shown on the left side of figure 8-6. The temperature of the facility re-circulating cooling water discharged from the cooling tower can be controlled by controlling the flow of air through the cooling tower. Reducing airflow increases temperature. The flow control damper may be part of the tower as shown on figure 8-6 or may be installed at the inlet or discharge of the fan. Most towers are equipped with mist eliminators. Mist eliminators reduce the amount of water droplets carried out of the cooling tower.

(3) In facilities with variable facility re-circulating cooling water demands, several cooling tower units may be manifolded in parallel. As the cooling load decreases, cooling tower units may be taken out of service so that the facility re-circulating cooling water temperature can be maintained at the proper value. In multiple cooling tower installations, valves are usually installed so that the tower is completely isolated from the facility re-circulating system. These valves may be remote-operated as shown on figure 8-6. Multiple cooling tower installations with all of the towers discharging into a common air discharge duct may also isolate the air side of the tower with an isolation damper. The isolation damper may be in addition to the airflow control damper. The isolation damper prevents moist air from other units from backflowing into the facility through an out of service unit. The isolation damper also allows personnel entry into out of service units to perform maintenance activities.

## **8-2. Cooling system major components**

Cooling systems are generally comprised of the following major components.

*a. Heat exchangers.* Diesel engine installations utilize heat exchangers to control the temperature of engine coolant, lube oil, fuel oil, and combustion air. Temperature is controlled by heat transfer through a tube wall or plate surface to another fluid (gas or liquid). Control of the above temperatures maintains the engine temperature. The most common type of heat exchanger used in the diesel engine cooling system is a tubular heat exchanger. Engine coolant heat exchangers are usually air-cooled or water-cooled. Air-cooled units are referred to as radiators. A radiator consists of an inlet box and a discharge box connected by many small diameter tubes arranged so that air flows through the tube bundle around the outside of the tubes. The tubes usually have fins on the outside surfaces to enhance the heat transfer between the tube surface and the cooling air. Radiator units are usually equipped with a thermostatically controlled fan that moves air through the tube bundle.

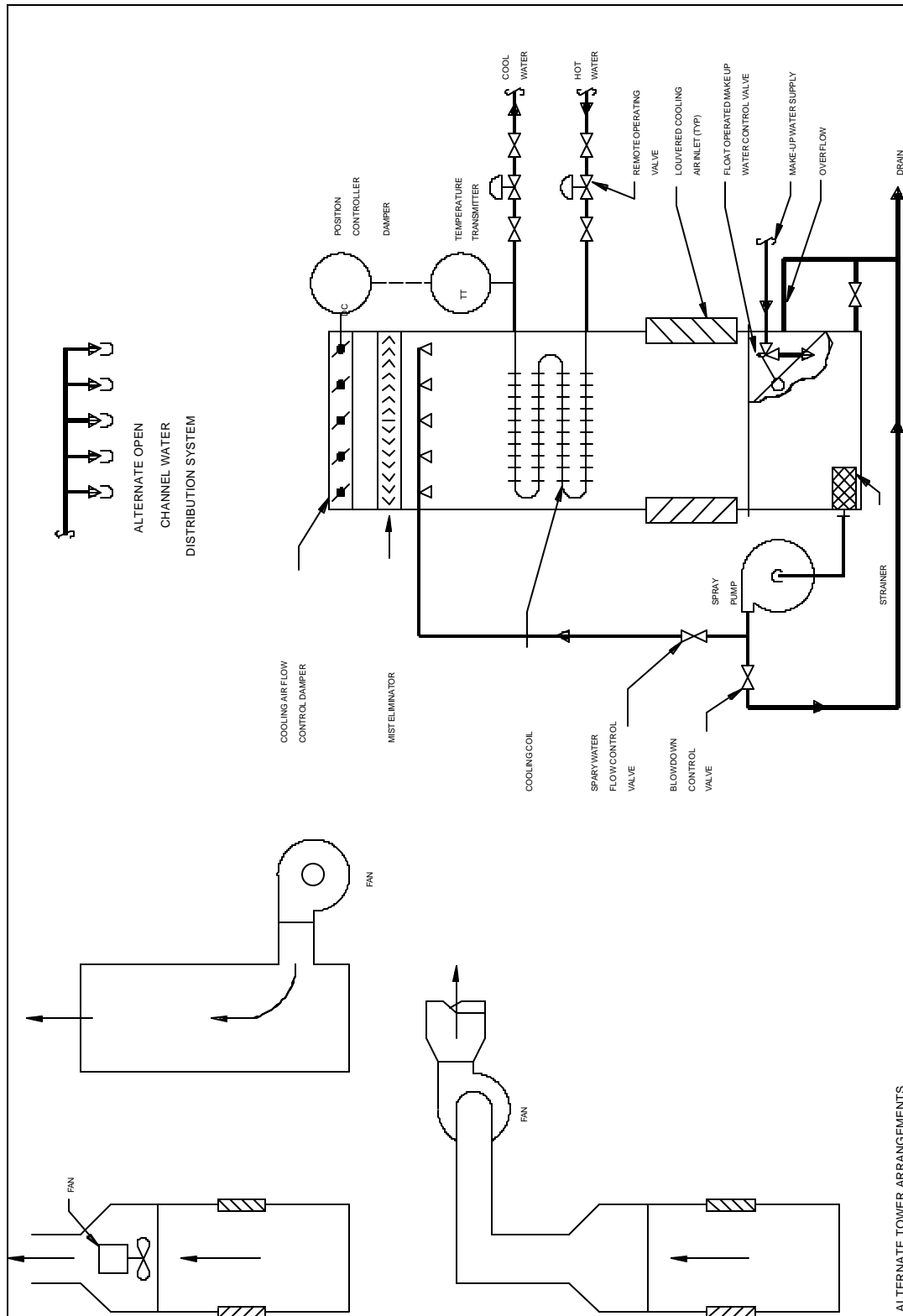

Figure 8-6. Typical evaporative cooling tower

*b. Air separators.* Some diesel engine cooling systems use air separators to remove air (gas) bubbles that have become entrained in the cooling fluid. Some air separators are just a tank constructed so the coolant inlet is not in a direct line with the coolant outlet. The surface area of the tank is large compared to the coolant piping. The slowing of the coolant stream and change in direction allows gas bubbles to rise to the surface of the tank or into the coolant expansion tank to be vented. A very common air separator is a mechanical separator with a tangential entry that causes the coolant stream to spin from an upper entry to a lower discharge. The resulting turbulence enhances gas separation. Tangential entry mechanical separators generally require less space than tank type separators, but require that the circulating pump is capable of producing higher differential pressures.

*c. Expansion tanks.* When coolant is heated, it expands. If the cooling system was completely closed, the forces generated by expansion of the coolant could damage the engine. The expansion tank provides space for coolant expansion. The expansion tank also provides added coolant capacity to make up for small losses. The expansion tank is generally installed some distance above the engine to provide a static head to prevent coolant flashing to steam which might result in cavitation in coolant circulating pumps.

*d. Pumps.* Various types of pumps are utilized in cooling systems.

(1) The pumps that circulate coolant when the engine is operating are generally mounted on the engine and are gear-driven by the engine. The pumps are generally furnished by the engine manufacturer with the engine so the design of the pump may vary from manufacturer to manufacturer. The most common pump design is a single-stage, end suction, centrifugal pump. The pump housings are generally cast iron, and the pump impeller and shaft bearings are generally bronze.

(2) The keep warm circulating pump circulates engine coolant through a keep warm heater when the engine is not operating. The keep warm pump is typically a single-stage, end suction, centrifugal type driven by an electric motor. Pump housings are generally cast iron or carbon steel, and the pump impeller and shaft bearings are generally bronze. The pump is generally direct-connected to the electric motor.

(3) The type of pump used to circulate cooling water in facility recirculating cooling water systems varies with the design of the system. The pumps are generally driven by direct-connected electric motors. Common types of pumps that may be used are as follows.

(a) Centrifugal pumps, horizontal, are preferred for pumping from aboveground water supplies which continuously flood the pump suction. These pumps may also be used to pump from reservoirs below the pump if the net positive suction head capability of the pump is not exceeded. When drawing from reservoirs below the pump, it is common practice to install foot valves at the inlet to the suction piping, so the suction piping remains full when the pump is not in operation.

(b) Centrifugal pumps, vertical, may be used, but are not preferred, for pumping from pits, ponds, or reservoirs, or from horizontal tanks where the pump extends down into the fluid to be pumped from a platform above the fluid. These pumps may have multiple stages.

(c) Turbine pumps, vertical, are preferred for pumping from pits, ponds, reservoirs, or horizontal tanks where the pump extends down into the fluid to be pumped from a platform above the fluid.

(d) Positive displacement pumps are not generally used in facility re-circulating cooling water systems.

*e. Keep warm heaters.* Keep warm heaters are generally low density electric immersion units supplied as a package with thermostatic control units. The heaters are sized to keep engine coolant circulated by the keep warm pump at the design operating temperature of the keep warm system. The operating temperature of the keep warm system depends on the needs of the engine. Keep warm systems may provide temperatures as low as 70°F to temperatures just below the coolant temperature in an operating engine.

*f. Engine coolant temperature control valves.* Temperature control valves are used in engine cooling systems which use a coolant bypass to maintain either a constant coolant temperature at the engine coolant outlet or a constant coolant supply temperature. The most common engine coolant temperature control valve is a self-contained, factory-set, thermostatic element-operated, sealed, three-way valve unit. When installed to maintain a constant coolant outlet temperature, the unit is referred to as a diverting valve. When installed to maintain a constant coolant inlet temperature, the unit is referred to as a mixing valve. The valve is designed to maintain full coolant flow through the engine cooling system. A thermostatic element in one of the valve ports controls a sliding valve assembly that controls the flow through that port. In the closed position, all of the flow is from the inlet port and out the other port. As the thermostatic element moves the sliding valve off the valve seat, a portion of the flow is from the inlet and through the thermostatically controlled port. At full lift, all of the flow is through the thermostatic port. (Some valves operate the opposite of the preceding description.)

*g. Engine instrumentation and controls.* Typical instrumentation and controls used in engine cooling systems include the following.

(1) Pressure indicators are located throughout the engine cooling system with pressure ranges varying according to function.

(2) Level indicators are installed on all coolant expansion tanks for local indication.

(3) Level transmitters are installed where needed to provide a signal to a remote location or control room for engine coolant level indication.

(4) Level controllers usually provide control signals for high level alarm, transfer pump start and stop, and low level alarm.

(5) Temperature switches may be used to activate a high coolant temperature alarm. Temperature switches may also be used to shut the engine down when coolant temperatures reach the point where further operation may result in damage to the engine.

(6) A flow switch can be located in an overflow line out of the top of each day tank. When flow is detected by a flow switch, the fuel oil transfer pumps will deactivate.



## CHAPTER 9

### BOILERS

---

#### 9-1. Types of Boilers

The two most general classifications of heating boilers pertain to the method of manufacture, i.e., by casting (cast iron boilers) or fabrication (steel boilers). Those that are cast usually use iron, bronze, or brass in their construction. Those which are fabricated use steel, copper, or brass, with steel being the most common material.

*a. Steel boilers.* Steel boilers can be generally divided into two types: fire tube and water tube.

(1) In fire-tube boilers, gases of combustion pass through the inside of the tubes with water surrounding the outside of the tubes. The advantages of a fire-tube boiler are its simple construction and less rigid water treatment requirements. The disadvantages are the excessive weight per pound of steam generated, excessive time required to raise steam pressure because of the relatively large volume of water, and inability to respond quickly to load changes, again due to the large water volume. The most common fire-tube boilers used in facility heating applications are often referred to as scotch or scotch marine boilers, as this boiler type was commonly used for marine service because of its compact size (firebox integral with boiler section).

(2) In the water-tube boiler, the water is inside the tubes and gases of combustion pass around the outside of the tubes. The advantages of a water-tube boiler are a lower unit weight per pound of steam generated, less time required to raise steam pressure, a greater flexibility for responding to load changes, and a greater ability to operate at high rates of steam generation.

*b. Cast iron boilers.* Cast iron boilers are made in three general types: horizontal sectional, vertical sectional, and one-piece. Most of the sectional boilers are assembled with push nipples or grommet type seals, but some are assembled with external headers and screw nipples. Horizontal, sectional, cast iron boilers are made up of sections stacked one above the other, like pancakes, and assembled with push nipples. Vertical, sectional, cast iron boilers are made up of sections standing vertically, like slices in a loaf of bread. One-piece cast iron boilers are those in which the pressure vessel is made as a single casting.

#### 9-2. Types of systems

Boilers are generally used to provide a source of steam or hot water for facility heating and process needs.

*a. Steam and condensate.* In steam and condensate systems, heat is added to water in a boiler causing the water to boil and form steam. The steam is piped to points requiring heat, and as the heat is transferred from the steam to the building area or process requiring heat, the steam condenses to form condensate. In some very low-pressure saturated steam heating applications, the steam distribution piping may be sized to slope back to the boiler so that the steam distribution piping also acts as the condensate return piping (single-pipe system). In other low-pressure applications there may be steam supply piping and condensate return piping (two-pipe system) although the condensate system is open to the steam system. In typical packaged steam boiler operations, the boiler system may generate steam at about 150 psig for distribution throughout the facility and be lowered to the operating pressure of equipment supplied

through point-of-use pressure reducing stations. As heat is transferred from the steam, condensate is formed which collects in discharge legs until enough condensate is present to operate a trap that isolates the steam distribution system from the condensate system. In common facility heating applications, the condensate system is at atmospheric pressure and the system is arranged to drain the condensate to a central condensate receiver, or into local smaller receivers which pump the condensate back to the central condensate receiver.

*b. Hot water.* A boiler is used to heat water that is circulated through a closed loop piping system for general facility and service water heating. Low-temperature systems generally operate below 200°F. Medium-temperature systems generally operate at temperatures between 200 and 250°F. A feature of hot water systems is an expansion tank to accommodate the expansion of the water in the system as the water is heated. The expansion tank, when piped into the system on the suction side of the circulating pumps, also pressurizes the system to prevent flashing in the circulating pump, piping, and piping components. In many low- and medium-pressure systems, pressurization is maintained by flash steam in the expansion tank. In a few hot water systems, pressurization is maintained by maintaining a compressed gas blanket above the water level in the expansion tank.

*c. High-Temperature Hot Water.* High-temperature hot water systems, which operate above 250°F, are basically the same as hot water systems. High-temperature systems are generally installed when a process requires the higher temperature, a number of locations require small quantities of low-pressure steam that the high-temperature hot water can generate in a local converter, or high-temperature drop equipment can be used at end use points to minimize the size of water circulation piping required.

*d. Fuels.* Most facility boiler systems are fired using a combustible gas (typically natural gas or propane) or fuel oil. In many facilities, the boilers are designed to fire both a combustible gas fuel and a fuel oil. In these facilities, the combustible gas fuel is generally natural gas that is considered the primary fuel and fuel oil is considered to be the backup fuel. For an expanded discussion of fuel oil properties and fuel oil delivery systems, see chapter 5.

### 9-3. Boiler system major components

Boiler systems are comprised of the following major components.

*a. Feedwater heaters.* Feedwater heaters are energy recovery devices generally found only in large steam generating plants where all of the steam generated is not reduced to condensate by the steam user. This "waste steam" is reduced to condensate for return to the boiler in the feedwater heater. The boiler feedwater is used as a cooling medium to reduce the steam to condensate that increases the temperature of the feedwater and thereby increases the thermal efficiency of the boiler.

*b. Fuel heaters.* Many boilers firing heavy fuel oil require fuel heaters to reduce the fuel viscosity, so the fuel can be atomized by the burner system for complete combustion. For an expanded discussion of fuel oil properties and the function of fuel oil heaters, see chapter 5.

*c. Deaerators.* A deaerator is a special case of feedwater heater that is designed to promote the removal of non-condensable gases from the boiler feedwater. The principal gases of concern are oxygen, carbon dioxide, and ammonia, which are major contributors to boiler, and steam and condensate piping corrosion problems. In small steam plants, a portion of the steam generated by the boiler is used to operate the deaerator if "waste steam" is not available. Failure to maintain and properly operate the deaerator can lead to early failure of the boiler, steam using equipment, and the steam and condensate piping.

*d. Pumps.* In most hot water systems, the system circulating pumps are electric motor-driven, end suction centrifugal pumps. In steam systems, the condensate return pumps are typically electric motor-driven, end suction, centrifugal or turbine type pumps. Feedwater pumps are generally electric motor-driven, multiple-stage, end suction centrifugal pumps. The shutoff head of the pump must be greater than the steam or hot water system operating pressure.

*e. Combustion air blowers.* In many packaged boiler installations, the combustion air fan is designed and provided by the boiler manufacturer and is integral with the boiler housing. In installations where a stand-alone fan is provided, low-pressure centrifugal blowers are commonly used. An important characteristic of the blower is the ability to maintain a relatively constant air pressure over a wide range of airflows.

*f. Flues.* Flues (boiler firebox exhaust duct or boiler discharge stack) must be large enough to conduct the products of combustion away from the boiler with a minimum of duct friction loss. Flues may be fabricated from any material suitable for the operating temperature and pressure. Common materials of construction associated with packaged boiler installations are carbon steel and stainless steel.

#### **9-4. Boiler system controls**

The control configuration for a boiler installation depends on the size of the boiler, the requirements of the insurance company providing coverage for the facility, and the building codes of the locality in which the facility is located. The overall boiler control system is typically integrated through a control panel known as the burner management system which controls the boiler operation to maintain the system set point conditions and shuts down the boiler if an equipment damaging and life threatening condition is sensed. For most packaged boiler installations, the basic boiler control is a single-element, proportional control device. In the case of a steam boiler, the control device is a pressure sensing element that sends a signal to the burner management system to adjust the burner firing rate to maintain a set pressure in the steam distribution system. In a hot water boiler, the control device is a temperature sensing element. In large steam boiler installations, the control system may be a three-element, proportional-integral-derivative controller that not only responds to the system set pressure, but may also respond to the rate of change in parameters, such as pressure, steam flow, water level, etc. In multiple boiler installations, the burner management systems of each boiler may be controlled by a master plant controller (sometimes referred to as a lead-lag controller) to stage boiler operation to minimize on/off operation. They may also minimize frequent burner cycling which can cause thermal stresses leading to tube and tube sheet leaks. While a brief description of the common types of control components associated with packaged boilers follows, the best guide to facility boiler operation and boiler controls is the manufacturer's operating and maintenance instructions provided with the boilers.

*a. Common controls.* The following control devices are common to all boilers.

- (1) The forced draft fan motor drives forced draft fan directly to provide combustion air.
- (2) The forced draft fan motor starter energizes forced draft fan motor.
- (3) The forced draft fan furnishes all air, under pressure, for combustion of pilot fuel and main fuel, and for purging prior to burner ignition and after burner operation termination.
- (4) The ignition transformer provides high-voltage spark for ignition of gas pilot or light oil pilot.

(5) The modulating motor operates the rotary air damper and fuel valves through a cam and linkage system to provide proper air-fuel ratios under all boiler load conditions.

(6) The low fire switch is an internal auxiliary switch, cam-actuated by the modulating motor shaft, which must be closed to indicate that the air damper and fuel metering valve are in the low fire position before an ignition cycle can occur.

(7) The burner switch is a manually operated start-stop switch for directly starting and stopping operation of burner.

(8) The manual-automatic switch, when set at "automatic," subsequently operates at the command of the modulating control which governs the position of the modulating motor in accordance with load demand. When set at "manual," the modulating motor, through the manual flame control, can be positioned at a desired burner firing rate. The primary purpose of the manual position is for testing and setting the air-fuel ratio through the entire firing range.

(9) The manual flame control is a manually operated potentiometer that permits the positioning of the modulating motor to a desired burner firing rate when the manual-automatic switch is set on manual. It is used primarily for initial or subsequent setting of fuel input throughout the firing range. It has no control over the firing rate when the manual-automatic switch is set on "automatic."

(10) The modulating motor transformer reduces control circuit voltage to required voltage for operation of modulating motor (typically reduces 115 volt alternating current to 24 volt alternating current).

(11) Indicating lights provide visual information of flame failure, load demand, fuel valve (valve open), and low water.

(12) The program relay and flame safeguard control (flame safety system) automatically programs each starting, operating, and shutdown period in conjunction with operating limit and interlock devices. This includes, in a timed and proper sequence, the operation of the blower motor, ignition system, fuel valve(s), and damper motor. The sequence includes air purge periods prior to ignition and upon burner shutdown. The flame detector portion of this control monitors both oil and gas flames and provides protection in the event of loss of a flame signal. The control recycles automatically during normal operation, or following a power interruption. It must be manually reset following a safety shutdown caused by a loss of flame. Incorporated is an internal checking circuit, effective on every start, that will prevent burner operation in the event anything causes the flame relay to hold in during this period.

(13) The combustion air proving switch is a pressure sensitive switch actuated by air pressure from the forced draft fan. Its contacts close to prove presence of combustion air. The fuel valves cannot be energized, unless this switch is satisfied.

(14) The combustion air damper controls combustion air in proportion to fuel input for various load demands. May be of the butterfly, opposed blade, or rotary type.

*b. Steam controls (all fuels).* The following control devices are used with steam systems.

(1) The steam pressure gauge indicates boiler internal pressure.

(2) The operating limit pressure control breaks a circuit to stop burner operation on a rise of boiler pressure above a selected setting. It is adjusted to stop or start the burner at a preselected pressure setting.

(3) The high limit pressure control breaks a circuit to stop burner operation on a rise of pressure above a selected setting. It is adjusted to stop the burner at a preselected pressure above the operating limit control setting. This control is normally equipped with a manual reset.

(4) The modulating pressure control senses changing boiler pressures and transmits this information to the modulating motor to change the burner firing rate when the manual-automatic switch is set on automatic.

(5) The low water cutoff and feedwater pump control (typically float-operated) responds to the water level in the boiler. The control starts and stops the feedwater pump or operates the feedwater control valve to maintain the proper water level in the boiler. If the water level drops below the lowest safe water level for the boiler, the control shuts down the boiler.

(6) Most jurisdictions required two independent low water cutoff devices. The auxiliary low water cutoff also provides a signal to shut down the boiler if the water level drops below the lowest safe water level for the boiler.

(7) The water column provides visual indication of boiler water level. The water column and low water cutoff devices for a boiler are typically incorporated in the same piping assembly.

(8) The test valve allows the boiler to be vented during filling and facilitates routine boiler inspection. The test valve is typically incorporated in the same piping assembly as the water column and the low water cutoff.

(9) Safety valves relieve the boiler of pressure higher than the design pressure. Safety valves and discharge piping must conform to the American Society of Mechanical Engineers (ASME) Boiler and Pressure Vessel Code requirements.

c. *Hot water controls (all fuels).* The following control devices are used with hot water systems.

(1) The water temperature gauge indicates the internal water temperature.

(2) The water pressure gauge indicates the pressure in the boiler.

(3) The operating limit temperature control breaks a circuit to stop burner operation on a rise of boiler temperature above a selected setting. It is adjusted to stop or start the burner at a preselected operating temperature.

(4) The high limit temperature control breaks a circuit to stop burner operation on a rise of temperature above a selected setting. It is adjusted to stop the burner at a preselected temperature above the operating control setting. The high limit temperature control normally is equipped with a manual reset.

(5) The modulating temperature control senses changing boiler temperature and transmits this information to the modulating motor to change the burner firing rate when the manual-automatic switch is set on automatic.

(6) The low water cutoff breaks the circuit to stop burner operation if the water level in the boiler drops below a safe operating level.

(7) Most jurisdictions require two independent devices to terminate boiler operation in the event of low water. The auxiliary low water cutoff also provides a signal to stop burner operation if the water level in the boiler drops below a safe operating level.

(8) Relief valves relieve the boiler of pressure higher than the design pressure. Relief valves and discharge piping must conform to the ASME Boiler and Pressure Vessel Code requirements.

*d. Gas controls.* The following control devices are used with gas-fired boilers.

(1) The gas pilot valve is a solenoid valve that opens during the ignition period to admit fuel to the pilot. It closes after main flame is established. The sequence of energizing and de-energizing is controlled by the program relay and flame safeguard control. Some jurisdictions may require two independent gas pilot valves installed in series.

(2) When two independent gas pilot valves are required, a normally open vent valve is usually required to vent the section of gas piping between the valves whenever both gas pilot valves are de-energized. The vent valve closes when the gas pilot valves are energized.

(3) The gas pilot shutoff cock is a manually operated, non-lubricated plug valve for isolating the gas supply from the gas pilot valve.

(4) The gas pilot adjusting cock is a manually operated valve used to regulate the size of the gas pilot flame.

(5) The gas pilot aspirator is a venturi device using combustion air to improve the flow of gas to the pilot burner.

(6) The gas pilot pressure gauge indicates gas pressure in the supply line to the gas pilot.

(7) The gas pilot pressure regulating valve reduces incoming gas pressure to suit the requirements of the pilot burner. Most pilot burners require a gas pressure in the range of 5 to 10 inches of water column.

(8) The main burner gas flow control valve is modulated through a mechanical linkage to the modulating motor to regulate the flow of gas to the burner in proportion to the boiler load.

(9) The gas modulating cam is an assembly consisting of a quadrant, a series of adjustable allen head screws, and a contour spring to adjust gas input at any boiler load condition to attain the required air-fuel ratio. The position of the quadrant is controlled by the modulating motor.

(10) The main gas cock is a manually operated, non-lubricated plug valve for isolating the gas supply from the main gas valves.

(11) Most jurisdictions require two independent main gas valves in series. Main valves will open only after the program relay and flame safeguard control signals that a pilot flame has been established.

(12) The main gas vent valve is a normally open solenoid valve installed between the two main gas valves to vent gas to atmosphere should any be present in the main gas line when the gas valves are de-energized.

(13) The low gas pressure switch is a pressure-actuated switch that is closed whenever the pressure in the gas supply line is above a preselected pressure. If the gas pressure in the gas main drops below the set pressure, the low gas pressure switch opens breaking the circuit to the main gas valves which causes the main gas valves to close, terminating burner operation.

(14) The high gas pressure switch is a pressure-actuated switch that is closed whenever the gas supply line pressure is below a preselected pressure. If the gas pressure in the gas main rises above the set pressure, the high gas pressure switch opens breaking the circuit to the main gas valves which causes the main gas valves to close, terminating burner operation.

*e. Oil controls.* The following control devices are used with oil-fired (or dual fuel) boilers.

(1) The oil drawer switch is a limit switch which remains open preventing the burner from operating until the oil drawer burner gun is latched in the forward position.

(2) The atomizing air proving switch is a pressure switch that closes allowing the burner to operate when there is sufficient atomizing air pressure for proper burner operation. Oil valve(s) will not operate or will not remain open, unless the atomizing air proving switch remains closed.

(3) The air pump module provides the compressed air required to atomize the fuel oil for proper burner operation. It is started automatically by the program in the program relay and flame safeguard control system.

(4) The air pump motor drives the air pump and an air-cooling fan. The control for the motor operates in parallel with the forced draft fan motor.

(5) The air pump provides air for atomizing the fuel oil.

(6) The air filter, typically, an oil bath or viscous film filter element (see chapter 7 for an expanded discussion of air filter assemblies) is used to clean the air supply prior to entering the air pump.

(7) The check valve prevents lubricating oil and compressed air from surging back through the pump and air filter when the air pump stops.

(8) The air-oil receiver tank holds a supply of oil for lubricating the air pump. It separates lube oil from atomizing air before delivery to the burner nozzle.

(9) The atomizing air pressure gauge indicates the pressure in the atomizing air supply system near the connection to the burner.

(10) The lube oil level sight glass indicates the level of lubricating oil in the air-oil receiver tank.

(11) The lube oil cooling coil cools the lubricating oil before the oil enters the air pump. A fan driven by the air pump motor circulates cooling air over the coil.

(12) The lube oil strainer filters lubricating oil before the oil enters the air pump.

(13) The lube oil fill pipe and strainer are used when adding oil to the air-oil receiver tank.

(14) Some jurisdictions require a low oil pressure switch. When required, this pressure-actuated switch opens when the pressure in the fuel oil supply system drops below a set value.

(15) The oil solenoid valve opens when energized by the program relay and flame safeguard control system allowing fuel oil flow from the oil metering valve to the burner nozzle. Many jurisdictions require two independent oil solenoid valves in series for boiler fired-on light oils.

(16) The fuel oil controller is an assembly combining into a single unit the gauges, regulators, and valves required for regulating the flow of fuel oil. Most controllers have the following integral parts. In addition to the parts listed below, controllers on systems burning No. 6 or heavier fuel oil required additional parts that are described in paragraph 9-4.f.

(a) The oil metering valve is operated through a mechanical linkage to the modulating motor. The valve regulates the fuel oil supply to the burner nozzle in proportion to the boiler load.

(b) The oil modulating cam is an assembly consisting of a quadrant, a series of adjustable allen head screws, and a contour spring to adjust gas input at any boiler load condition to attain the required air-fuel ratio. The position of the quadrant is controlled by the modulating motor.

(c) The oil burner pressure gauge indicates the pressure in the fuel oil supply line at the inlet connection to the oil metering valve.

(d) The oil pressure regulator may be required to reduce the pressure in the facility fuel oil delivery system to a pressure compatible with the oil burner fuel oil supply regulating components.

(17) The oil relief valve bypasses excess fuel oil and maintains the fuel oil system pressure indicated on the oil supply pressure gauge.

(18) When a light oil pilot system is used, a solenoid valve is provided to control the flow of fuel to the pilot nozzle. The pilot valve is energized at the appropriate time by the program in the program relay and flame safeguard control system. It shuts off the flow of fuel to the pilot when the control system receives a signal that the main burner flame has been established. (Note: Many oil burners use a gas pilot system consisting of the components described in paragraph 9-4d.)

(19) The back pressure orifice is a restriction located in the oil return line immediately downstream of the fuel oil controller to maintain a set pressure in the fuel supply system. A back pressure orifice is generally only used on systems that do not use an oil relief valve.

f. *Heavy oil controls.* The following additional control devices are used when firing heavy oil.

(1) The oil heater switch is a manual disconnect for electric power to fuel oil heater system.

(2) The oil heater – electric – is used for heating sufficient fuel oil for operating burner at low fire during cold starts before steam or hot water is available for fuel oil heating. On steam boiler units, the electric heater is typically integral with the steam fuel oil heater. On hot water boiler units,



the electric heater is typically a stand-alone unit. The electric heater must be turned off during extended boiler lay-up or at any time fuel oil transfer is terminated.

(3) The oil heater – steam or hot water – heats the fuel oil to attain the proper fuel oil viscosity for full atomization of the fuel oil. On steam boilers operating at 15 psig or less, the steam heater typically operates at the same pressure as the boiler. On higher pressure steam boiler units, a pressure reducing station is typically installed in the supply line to the fuel oil heater to limit the steam pressure in the oil heater to 15 psig or less.

(4) The oil heater thermostat – electric and steam – senses fuel oil temperature. On electric heaters, energizes or de-energizes the electric heater to maintain the proper fuel oil temperature. On steam heaters, controls the operation of the steam flow control valve in the supply line to the heater to maintain temperature.

(5) The oil heater thermostat – hot water – senses fuel oil temperature and starts and stops a booster water pump which circulates hot water from the boiler through the oil heater to control the temperature of the fuel oil.

(6) The booster water pump circulates water from the hot water boiler through a hot water fuel oil heater. Operation of the pump is controlled by the hot water oil heater thermostat.

(7) The oil heater valve is a normally open solenoid valve opened by the steam boiler heater thermostat to allow flow of steam to the steam heater to maintain the temperature of the fuel oil.

(8) The steam heater supply check valve is installed in the steam supply line ahead of a steam oil heater, the check valve prevents oil contamination of the waterside of the pressure vessel should any leakage occur in the oil heater.

(9) The steam heater pressure regulator is used on steam boiler units that operate at pressures higher than 15 psig to reduce the steam pressure supplied to the steam oil heater to pressures compatible with the equipment.

(10) The steam trap drains condensate and prevents loss of steam from the steam oil heater. The discharge of the steam trap on the steam oil heater unit is typically discharged rather than recovered to eliminate the possibility of contaminating the waterside of the boiler in the event of a leak in the oil heater unit.

(11) The steam heater discharge check valve prevents air entry during shutdown periods when cooling action may create a vacuum within the steam heater.

(12) The oil supply pressure gauge is installed in the fuel oil supply line between the discharge of the fuel oil heater and inlet to the fuel oil controller unit oil pressure regulator.

(13) The low oil temperature switch is a temperature-actuated switch that prevents the burner from firing or terminates burner operation if the fuel oil temperature is lower than required for proper oil burner operation.

(14) High oil temperature switch. Some jurisdictions require a temperature-actuated switch that prevents the burner from firing or terminates burner operation if the fuel oil temperature is above a set temperature. This is the high oil temperature switch.

(15) The fuel oil controller units for boilers firing heavy oil require the following.

(a) The fuel oil thermometer indicates temperature of fuel oil being supplied to the fuel oil controller.

(b) The back pressure valve ensures that a minimum fuel oil supply system pressure is maintained for proper fuel oil controller operation.

(c) The oil return pressure gauge indicates the oil pressure on the return side of the fuel coil controller.

(d) The manual bypass valve is used when making a cold start. When open, bypasses control elements and allow oil circulation through the supply and return system to allow oil heaters to adjust the temperature of the fuel oil before firing the burner is attempted. The valve must be closed prior to firing the boiler.

(e) The orifice oil control valve may be opened prior to startup to aid in establishing fuel oil flow through the controller. Prior to firing the boiler, the valve must be closed.

(16) The air purge valve is a solenoid valve that opens simultaneously with closing of oil solenoid valve at burner shutdown allowing compressed air to purge oil from the burner nozzle and adjacent piping. This oil is burned by the diminishing flame which continues burning for approximately four seconds after the oil solenoid valve closes.

(17) The air purge orifice nozzle limits purging air to proper quantity for expelling unburned oil at the normal delivery rate.

(18) The air purge orifice nozzle filter filters the purging air of any particles that might plug the air purge orifice nozzle.

(19) The air purge check valve prevents fuel oil from entering the atomizing air line.

(20) The air purge relay, when energized, controls the operation of the air purge valve.

g. *Additional controls for dual-fuel burners.* Boilers with dual-fuel burner systems require a selector switch to tell the control system which set of fuel controls to operate.

h. *Economizer.* An economizer is an energy recovery device that uses the hot exhaust gases from the boiler (waste heat) to heat combustion air or feedwater.

i. *Steam traps.* Steam traps are installed throughout steam systems to remove condensate (spent steam), air, and non-condensable gases from the steam system. There are five types of steam traps in general use today. While other types have been designed and built, the requirements of industry have centered around the five basic types described below.

(1) The heart of a balanced pressure thermostatic trap is the flexible bellows that moves the valve head from its seat to discharge the condensate. The bellows is filled with a volatile fluid and hermetically sealed. The fluid has a pressure-temperature relationship that closely parallels, but is approximately 10°F below that of steam.

(2) The liquid expansion steam trap has for its operating element a liquid-filled cartridge. Within this cartridge is a hermetically sealed bellows which is attached to the valve head and plunger.

(3) Float and thermostatic steam traps provide immediate and continuous discharge of condensate, air, and non-condensables from a steam system as soon as they reach the trap. The trap consists of a ball float connected by a lever assembly to the main valve head. As condensate reaches the trap, the ball float rises, positioning the valve to discharge the condensate at the same rate as it reaches the trap.

(4) The inverted bucket steam trap is a type of trap with an inverted bucket attached to the valve head by a lever mechanism and operates to open and close the trap. When condensate enters the trap, a water seal is formed around the bottom of the inverted bucket which, since it is filled with air, becomes buoyant and rises and closes the trap. A small hole in the top of the inverted bucket allows air to escape with condensate taking its place inside the bucket. The inverted bucket loses its buoyancy and sinks to the trap bottom, opening the valve to discharge the condensate.

(5) Thermodynamic steam traps are a type of steam trap which responds to differences in kinetic energy between steam and condensate to open and close the valve for discharging condensate.

*j. Piping.* Piping 2 inches and smaller used in steam and hot water systems is typically schedule 80, American Society for Testing and Materials (ASTM) A 106, Standard Specification for Seamless Carbon Steel Pipe for High-Temperature Service (1999), Grade B, steel pipe with threaded joints and carbon steel fittings. Piping larger than 2 inches is typically standard weight, ASTM A 106, Grade B, steel pipe with flanged joints and carbon steel fittings.

## CHAPTER 10

### INCINERATORS

---

#### 10-1. Incineration system description

Incineration of waste is an operation that includes feeding the furnace, burning the waste, exhausting the gases to the atmosphere, and removing the residue from the furnace. This chapter presents an overview of incinerators and associated fans, burners, and control equipment required for a complete refuse disposal system. Typical incineration system equipment is described, as well as guidelines for maintenance of such systems.

*a. Waste classification.* Incinerators and associated equipment are available in a wide variety of designs based on the type of refuse, unit capacity, and degree of process automation. For the purpose of this manual, discussion will be limited to manually fed, low capacity units (less than 250 pounds per hour) with dry paper as the primary waste. Dry paper matter is classified as a Type O waste with the following characteristics.

Moisture content	Less than 10 percent
Incombustible solids	5 percent
BTU value per pound	8,500
Weight per cubic foot	8 - 10 pounds

*b. System design features.* The feed system for incinerators may be automatic or manual (batch); however, for small scale systems associated with paper waste, the waste is typically batch-fed into a charging hopper or directly into the furnace. Auxiliary gas or oil burners assist in the combustion of the waste and help in maintaining the desired combustion temperature. The required furnace draft is provided by the stack or by an induced draft fan, and is monitored closely to ensure that the proper negative air pressure is maintained in the furnace. Residue generated from burning dry paper consists of a relatively fine, light ash. Removal of this residue from the furnace may be by automatic equipment or by manual means. For manually fed, low capacity incinerators as described in this chapter, ash removal is generally manual through cleanout doors located below the furnace grate.

#### 10-2. Incineration system major components

Incineration systems are comprised of the following major system components.

*a. Combustion chambers.* The combustion chamber(s) of an incinerator enclose the combustion area and are typically constructed of an outer shell and an inner refractory material lining. Shell materials vary with size and age of the incinerator, and are usually brick for older built-up units and steel or cast iron for newer packaged units. The refractory lining serves to protect the shell from the high temperatures generated in the chamber. Incinerators may have one or two combustion chambers. Newer packaged incinerators generally will have two chambers (figure 10-1), primary (lower) and secondary (upper), whereas older built-up incinerators may have only a single combustion chamber.

(1) The primary combustion chamber houses the fixed grate or hearth, waste charging door, ash removal doors, and primary burner. Initial burning of the waste occurs in this chamber, with combustion air

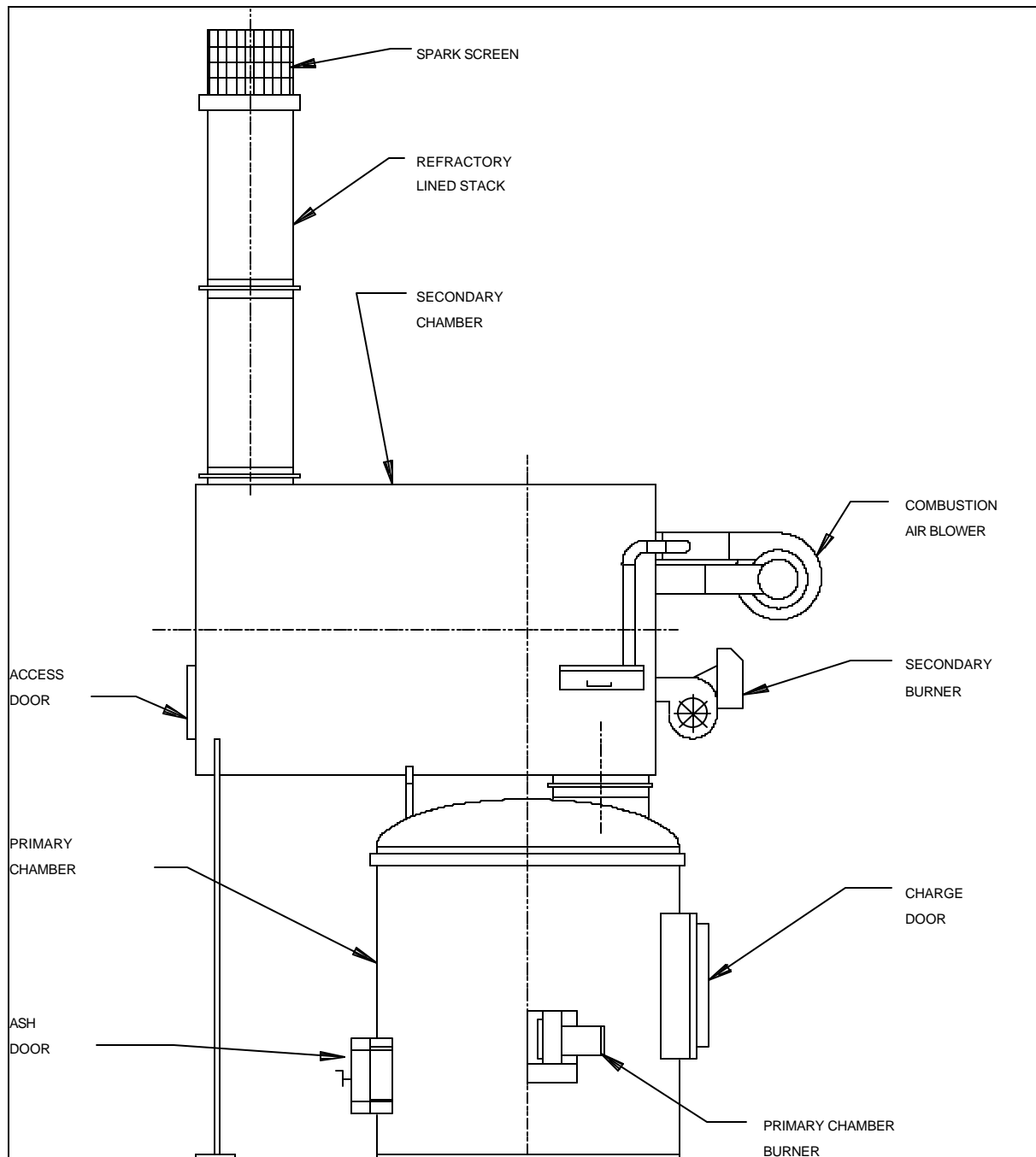

*Figure 10-1. Vertical dual chamber incinerator*

supplied in the grate area by air vents or by a combustion air blower. Partial combustion occurs in the primary chamber, with the hot gases generated flowing up into the secondary combustion chamber. The temperature within the primary chamber is maintained around 1,300°F by controlling the combustion air and the firing rate of the burner.

(2) Further combustion of the gases occurs in the secondary combustion chamber that is usually located above the primary chamber. Secondary combustion is augmented by an auxiliary burner, with air supplied by additional vents or blowers. To minimize pollution, the temperature within the secondary

chamber should be maintained at 1,800°F, and the residence time should be a minimum of two seconds. The combustion gases exit the secondary chamber and are discharged to the stack.

*b. Burners.* Incinerators will have auxiliary burners to assist in the combustion of the waste. Burners serving the primary combustion chamber heat and ignite the waste. Burners serving the secondary combustion chamber aid in maintaining the temperature required to minimize emissions. Incinerator burners may be natural gas or oil fired, with controls ranging from manual on/off operation to fully automatic modulating operation. Safety controls are typically provided to ensure proper burner ignition and operation, and to prevent flow of fuel into the chamber if ignition has not occurred.

*c. Fans.* Fans serving incinerator systems may be provided to supply combustion air (forced draft fans) or to aid in exhausting the flue gases from the incinerator to the stack (induced draft fans). The combustion air fans are generally the centrifugal type and are mounted on or near the combustion chambers. The induced draft fan is located in the flue gas stream between the incinerator and the stack. Induced draft fans are usually of centrifugal or axial design, and are constructed to handle the high temperatures and particulate of the combustion gases. Controlling the forced draft and induced draft fan output enables the proper temperature and draft (pressure) to be maintained within the incinerator. Fan output may be controlled by dampers or by variation of motor speed. Damper control generally consists of adjustable fan discharge dampers or adjustable fan intake dampers (inlet vanes). Motor speed control can be accomplished by several methods including use of variable speed direct current (DC) motors, use of multiple speed alternating current (AC) motors, or electronically adjustable motor drives. The pressure within the incinerator is usually monitored by a draft gauge calibrated in inches of water.

*d. Air pollution control equipment.* For the purpose of this manual, it is assumed that the low capacity incinerators located on existing sites are not equipped with air pollution (emission) control devices. A brief discussion of this equipment is provided since it is likely that systems may be required to be retrofitted in the future due to increasingly stringent regulations. Emission regulations vary from state to state, but generally speaking, low capacity (250 to 500 pounds per hour) incinerators are exempt from emission equipment requirements. Most states do, however, require that a temperature of 1,800°F be maintained within the incinerator to ensure more complete combustion, thereby reducing emissions. Pollution control equipment serving incinerators includes wet and dry scrubbers, electrostatic precipitators, and baghouses. Any one or a combination of these devices may be used depending on the incinerator size, waste to be incinerated, system configuration, and emission regulations. Wet and dry scrubbers are generally used to neutralize the acid gases that are generated in the combustion process. The flue gases also contain a fine particulate matter that may be collected by an electrostatic precipitator or baghouse for complete emission control. Addition of pollution control equipment to an incinerator system will generally mandate the use of an induced draft fan to overcome the significant air resistance caused by this equipment.

# CHAPTER 11

## CHILLED WATER SYSTEMS

---

### 11-1. Chilled water systems description

A chilled water system is a means by which heat, generated in a space or by a process, is conveyed from that space and ultimately released to the outside. This chapter is intended to acquaint the facility operator with chilled water systems and identify a minimum level of maintenance activities that must be performed to maintain a chilled water system for continuous day-to-day operation. Each chilled water system is designed to transfer heat by the most efficient and cost-effective method. While there is no right way to design a chilled water system, chilled water systems have common characteristics and use common types of components. Due to these differences in chilled water systems, the individual chilled water system equipment manufacturer's directions regarding maintenance practices take precedence over any guidance provided in this chapter.

*a. System functions.* Basically, a chilled water system circulates the chilled water through a loop piping system. Pumps force the water from the water chiller through the heat transfer components and back to the chiller via the piping system. Heat is transferred to the chilled water as it circulates through the heat transfer device that causes the temperature of the chilled water to increase. The portion of the system that supplies the water from the chiller to the heat transfer equipment is typically designated the chilled water supply system. Once the water is through this heat transfer equipment, the piping system delivering it back to the chiller is termed the chilled water return system.

*b. Piping systems.* There are two common types of chilled water piping systems: two-pipe and dual-temperature, with numerous variations of each. Two-pipe systems for comfort air conditioning typically operate with a design supply temperature of 40 to 55°F and a system pressure of approximately 125 psi. Antifreeze or brine solutions may be used for chilled water systems (usually process applications) that require supply temperatures below 40°F. In addition, well water type chilled water systems can use supply temperatures of 60°F or higher. Dual-temperature systems are a combined water heating and cooling system that circulate hot and/or chilled water to heat or cool with common piping and terminal heat transfer apparatus. This chapter will consider two-pipe chilled water systems that supply 40 to 55°F supply water only; however, much of the information presented in this chapter will apply to dual-temperature systems as well.

### 11-2. Chilled water systems major components

Chilled water systems are generally comprised of the following major system components.

*a. Chillers.* The most common chilled water air-conditioning system is a single compressor and refrigerant circuit using a water-cooled condenser. It is relatively simple and compact. Compression type refrigeration liquid chilling equipment ranges in size from quite small to those with capacities in the thousands of tons (1 ton equals 12,000 BTU per hour of cooling). The three categories of chillers that will be discussed in this chapter are those which use reciprocating compressors, centrifugal compressors, and rotary screw type compressors. Control of water chillers is typically based on the return water temperature. The return water temperature indicates the cooling load in the facility at any given time. The warmer the chilled water return temperature, the larger the facility cooling loads. Occasionally, the chiller is controlled by the leaving water (supply) temperature. This is typical for process chilled water applications. In this case, the rotary screw compressor or the centrifugal compressor will usually respond

best and will provide modulating control to meet the load.

(1) Reciprocating type chiller compressors are available in capacities from about 2 to 200 tons. Reciprocating water chillers may have one, two, or more compressors, each of which is matched to a separate tube circuit in a common shell, and each with its own expansion valve, service valves, dryer, piping, and controls. The compressors may be piped to use a common water-cooled condenser or may each have their own water-cooled condensers. Chillers are also built with air-cooled condensers as part of a package for outdoor use, or can be built for use with a remote air-cooled condenser or an evaporative condenser. The principles of operation of all reciprocating compressors are much the same. Suction gas (from the evaporator) is drawn into the compressor through the suction shutoff valve to the suction chamber and on through a suction filter. The filter separates the lubricating oil from any liquid refrigerant that is mixed with the refrigerant gas. Since reciprocating compressors are made to pump refrigerant gas only, any liquid refrigerant must be separated from the gas to keep from doing any damage to the compressor valves. The gas then flows through the crankcase and then to the cylinders. The piston in the cylinder compresses the refrigerant that is discharged through the discharge opening. Water chillers which use reciprocating type compressors are of three main groups: hermetic, semihermetic, and open direct drive type.

(a) A hermetic unit uses a hermetic compressor with the electric motor totally enclosed in the refrigerant atmosphere. The possibility of refrigerant leakage to the outside through a shaft seal is totally eliminated, and motor operating noise is subdued by the housing. Because this type of forced refrigerant cooling of the motor is very effective, smaller, less expensive motors can be used. The need for a heavy external base to preserve motor-compressor shaft alignment is eliminated. Hermetic machines are less expensive than external drive machines, have slightly greater power consumption, and are quieter. However, should the motor fail, the repair cost is higher, and the unit must be replaced with a like unit or sent back to the manufacturer for service. These compressors are used in most cases for a small refrigeration or air-conditioning system.

(b) The semihermetic compressor, like the hermetic type, has both the compressor and its drive motor in the same casing. The term "semihermetic" means that the case in which both the compressor and motor are sealed may be opened for service or repair.

(c) Open direct drive type compressors are those in which the crankshaft, which is fitted with a shaft seal, extends from the housing. They do not have a drive motor as an integral part, but the drive motor in most cases is placed on the same base with the compressor. The motor may be joined to the compressor with a direct drive coupling or belt drive.

(2) Centrifugal compressors which are used as part of many large refrigeration and air-conditioning systems move a large volume of refrigerant at low pressures. They are made in sizes as great as 10,000 tons. The only wearing parts in a centrifugal compressor are the main bearings and the main seals. However, hermetic type centrifugal chillers do not have main seals. All centrifugal compressors do not have pistons. In this type of compressor, the refrigerant gas from the evaporator is pulled through the suction line into the center of the impeller. The impeller which is rotating at a high speed forces the gas flow to the outside edge of the impeller and out the impeller housing. The hot, high-pressure refrigerant gas then flows to the condenser. A centrifugal compressor may have one or more stages. These stages may be in the same or in separate impeller housings.

(3) The rotary screw type compressor uses a mated pair of special helical rotors. They trap and compress the refrigerant gas as they revolve in an accurately machined compressor cylinder. The helical rotors are made with the male rotor having four lobes and the female rotor having six interlobe spaces.



The male rotor often drives the female rotor, but in some cases they are both gear-driven. These compressors are built in either external drive or semihermetic construction. They are used in larger systems that range in size from 20 to 800 tons. These compressors are commonly used with R-134a, R-22, and R-717 (ammonia) refrigerants. An oil injection system is used that gives high-efficiency and smooth operation. As the lobe of the male rotor starts to unmesh from an interlobe space of the female rotor, a void is made and gas is drawn in through the inlet port. As the rotors continue to turn, the interlobe space increases in size and more gas flows into the compressor. Just prior to the point at which the interlobe space leaves the inlet port, the entire length of the interlobe is filled with refrigerant gas. As rotation continues, the trapped gas in the interlobe space is moved circumferentially around the compressor housing at a constant pressure. Further rotation starts the meshing of another male lobe with the female space on the suction end and progressively compresses the gas in the direction of the discharge port. Thus, the occupied volume of the trapped gas within the interlobe space is decreased, and the gas pressure as a result increases. As this gas is discharged, a fresh charge of refrigerant is drawn through the inlet on the opposite side.

*b. Water chiller auxiliary systems.* Auxiliary systems used to enhance chiller performance and to aid maintenance activities include the following.

(1) Purge units are required for centrifugal liquid machines using low pressure refrigerants (such as R-123), because evaporator pressure is below atmospheric pressure. If a purge unit was not used, air and moisture would accumulate in the refrigerant over time. These noncondensables drastically reduce the capacity and efficiency of the chiller operation. A purge unit is designed to prevent the accumulation of noncondensables and ensure internal cleanliness of the liquid chiller. Purge units may be manual or automatic, compressor-operated, or compressorless.

(2) A refrigeration transfer unit may be provided for centrifugal liquid chillers using refrigerants with a boiling point below ambient temperature at atmospheric pressure (R-134a, R-22). This system is used for adding and removing refrigerant to and from the chiller. The unit consists of a small reciprocating compressor with electric motor drive, a condenser (air-cooled or water-cooled), an oil reservoir, an oil separator, valves, and interconnecting piping.

(3) Air-conditioning equipment is generally selected on the basis of maximum design condition and is then expected to cope with a variety of conditions, some of which may force the equipment outside of its stable operating range. At light cooling loads, operating the chiller at its maximum capacity will cause frosting of the coil, excessive compressor cycling, and possible liquid carry-over. Hot gas bypass is a system that, at some predetermined partial loading, allows flow of hot refrigerant gas from the high-pressure side to the low-pressure portion of the refrigerant system. This reduces the condenser capacity to produce refrigeration, because the gas returned to the low-pressure side produces no useful cooling; instead it becomes an evaporator load. This enables the chiller to operate over a broader range of conditions and avoid freeze-ups and cycling problems.

*c. Pumps.* The type of pump used to distribute chilled water through the chilled water system varies with the system design. There are two basic types of pumps: positive displacement and centrifugal.

(1) Positive displacement pumps trap the liquid in internal cavities and move it from the inlet of the pump to the discharge. This action increases the velocity and pressure of the liquid which flows in the discharge pipe. Positive displacement pumps are rarely used in chilled water systems.

(2) Centrifugal pumps are the most commonly used pumps in refrigeration and air-conditioning systems and are classified by their mechanical features, installation arrangement, mounting position, and

method of connection to the electrical motor. figure 11-1 shows several types of centrifugal pumps. Centrifugal pumps have three main parts: a prime mover (typically electric motor), an impeller, and a body. The motor is often connected to the pump shaft by a flexible type coupling. Some centrifugal pumps are built with the motor and pump impeller on the same shaft. In all cases, the pump impeller is connected to the shaft and turns the same speed as the motor. The impeller is the part of the pump that causes the water to move through the pump body. Impellers vary widely in their construction. The centrifugal force that comes from the rotating impeller moves the water or other liquids through the channels that run between the vanes. The outward-moving water streams are directed by the volute in a single stream that flows out of the pump discharge. This action of the impeller builds up the pressure of the water at the pump outlet.

*d. Expansion tanks.* Expansion tanks are used in chilled water systems for two purposes. First, expansion tanks allow for thermal expansion of the chilled water that, if not for the expansion tank, could damage the piping system. Secondly, the expansion tank provides a location for makeup water to be admitted to the system. The expansion tank is connected to the chilled water system on the inlet (suction) side of the distribution pump(s) by a branch line. The makeup water line is typically connected to this branch line between the expansion tank and the main pump inlet pipe.

*e. Control valves.* Control valves are used in chilled water systems to control the flow of chilled water through the piping system. The control system positions the valve through a valve operator or actuator that is directly attached to the valve stem. The valve operator or actuator uses electricity, compressed air, or hydraulic fluid to move the valve stem through its operating range.

*f. Thermal storage.* Thermal storage is the temporary storage of high- or low-temperature energy for later use. The purpose of thermal storage is to lower overall energy costs by generating and storing cooling medium during periods when electrical rates are at their lowest (off-peak). This occurs typically during the night or during periods of light air-conditioning loads.

(1) There are two types of storage strategies: full storage and partial storage. In full storage systems, the entire cooling load for a design period of time is generated during the off-peak time and stored for use during the following design period. In partial storage systems, only a portion of the design period cooling load is generated and stored during the previous off-peak period. During the peak period, the cooling load is satisfied by simultaneous operation of the cooling equipment (chillers) and withdrawal from storage.

(2) There are two thermal storage system options available for large commercial and industrial cooling applications: chilled water storage and ice storage.

(a) Chilled water storage systems use conventional chillers, pumps, and piping systems. They also require large storage tanks for chilled water. In this system, chilled water is generated during off-peak periods and stored in a storage tank. During peak cooling periods, the stored chilled water is pumped from the tank to the cooling equipment (air handler coils, etc.) and then returned to the storage tank.

(b) There are several types of ice storage systems that are used to store thermal energy. Ice storage typically has the advantage over chilled water storage in that it requires less space.

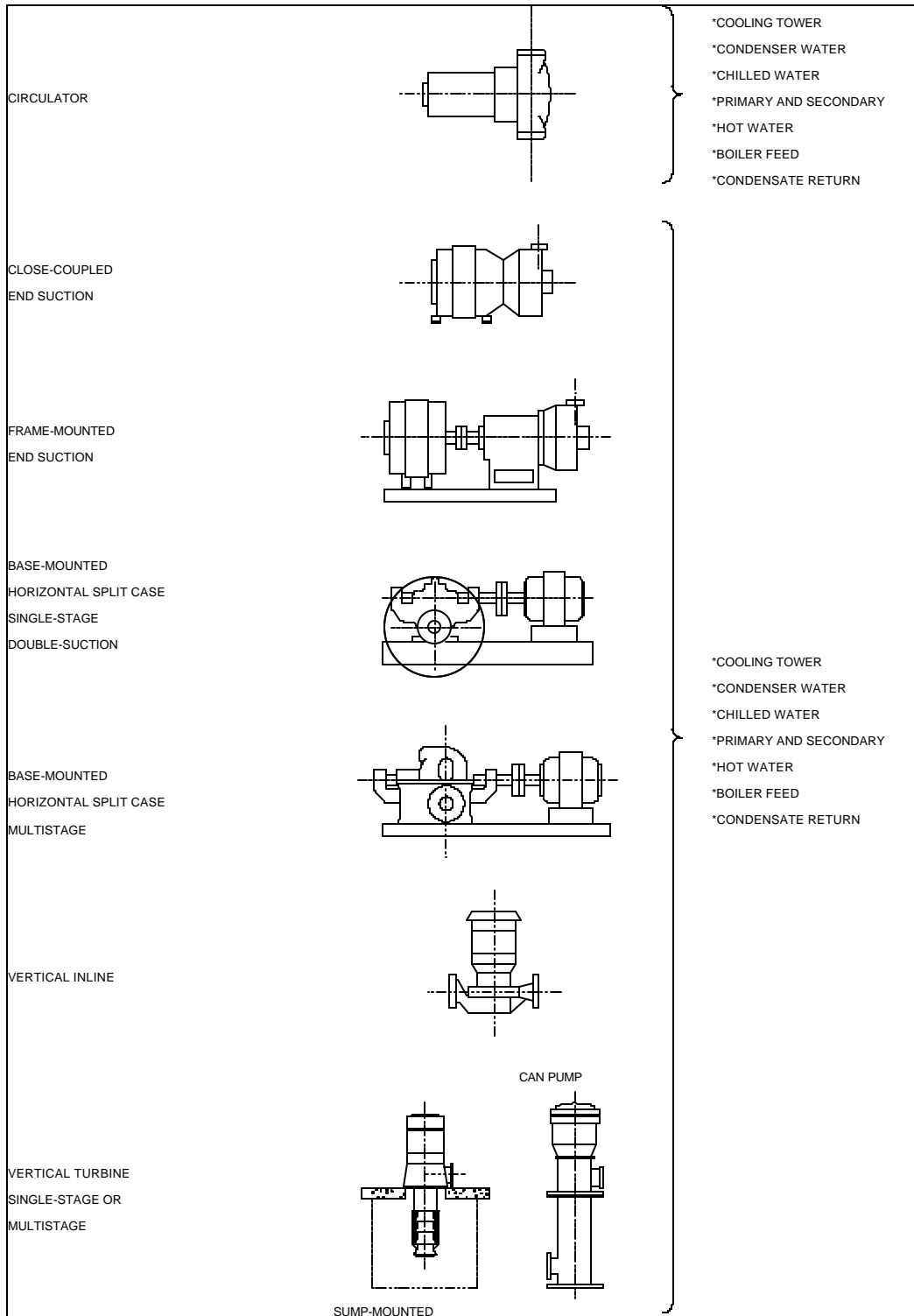

Figure 11-1. Variations of centrifugal pumps

*g. Heat exchangers.* A heat exchanger is any device that affects the transfer of thermal energy from one fluid to another. In the simplest exchangers, the hot and cold fluids mix directly; more common are those in which the fluids are separated by a wall. Common heat exchangers include the flat-plate, shell-and-tube, and cross-flow types. A double-pipe heat exchanger, the simplest form of the shell-and-tube, can have the fluids both flow in the same direction. It is referred to as a parallel-flow type. If they flow in opposite directions, it is referred to as a counter-flow type. A shell-and-tube exchanger may also have several tubes, two-passes, and baffles. In cross-flow heat exchangers, the fluids flow at right angles to each other. The evaporator and condenser sections of water chillers are examples of shell-and-tube type heat exchangers that are an integral part of the water chiller package. Heat exchangers are also designed and used as stand-alone thermal heat transfer devices in chilled water systems, heating water systems, and steam systems.

*h. Strainers.* Strainers are defined as closed vessels with cleanable screen elements designed to remove and retain foreign particles down to 0.001 inch diameter from various flow fluids. A strainer differs from a filter in that strainers trap particles that are typically visible to the naked eye. Strainers are typically installed in chilled water systems on the inlet (suction) side of the distribution pumps.

*i. Air separators.* All chilled water systems use air separators to remove air (gas) bubbles that have become entrained in the water. One type of air separator is simply a tank constructed so that the chilled water inlet is not in a direct line with the outlet from the tank. The diameter of the tank is large compared to the chilled water piping. As the chilled water enters the expansion tank, the flow is slowed down considerably. This slowing of the flow, together with the change in direction of the chilled water flow, allows the air to rise to the surface of the tank or into the expansion tank to be vented. A more common type of air separator is a mechanical type air separator with a tangential entry that causes the chilled water to spin down from an upper entry to a lower discharge. The resulting turbulence enhances the air separation. Tangential entry mechanical separators generally require less space than tank type separators, but require that the circulating pump be capable of producing higher differential pressures. The air separator is typically installed in the chilled water supply piping between the chiller and the distribution pump. Air separators should be fabricated, tested, and certified in accordance with the appropriate sections of the American Society of Mechanical Engineers (ASME) Boiler and Pressure Vessel Code for unfired pressure vessels.

*j. Valves.* Valves installed in the chilled water system are used to control water flow and to isolate equipment for ease of maintenance. Most valves in a chilled water system are manually operated with a handwheel or lever operator.

(1) Valves are rated in terms of saturated steam pressure; nonshock cold water, oil, or gas pressure (WOG); or both. Valve ratings are usually stamped or cast into the valve body. A valve with the markings "125" or "200 WOG" will operate safely at 125 psig of saturated steam or 200 psig of cold water, oil, or gas.

(2) Valves generally should be installed with the stem in the vertical up or horizontal position. Gate valves should be installed with the stem in the horizontal position and the bottom half of the valve disk opening in the direction of flow. Check valves are best-suited for horizontal installation, unless specifically designed for vertical installation. Special care must be taken when welding, soldering, or brazing valve end connections. All valve components not capable of withstanding the temperatures generated should be removed or cooled during installation. Valves are typically installed at the following locations.

(a) On the inlet and outlet connection of each piece of equipment, including chillers, pumps, reducing valves, control valves, tanks, coils, and other equipment that requires periodic maintenance.

(b) On the supply and return branch lines at the point of connection to the main supply and return piping headers.

(c) Drain valves are installed at low points in the water distribution system to facilitate draining of the system.

(d) Vent valves should be installed at all high points in the chilled water piping system for manual venting of air from the system and to help in the draining of the piping.

(3) The most common types of valves utilized in chilled water systems include gate, ball, butterfly, globe, check, and pressure regulating valves. The general characteristics of these valves are described below. Illustrations of these valves are located on figures 11-2 and 11-3.

(a) Gate valves are identified by a wedge-shaped disk that is raised to open or lowered to close the valve. Gate valves are intended to operate fully open or fully closed, and have very low resistance to flow in the open position, since the disk rises out of the flow path. The gate valve should not be operated in the partially open position, as this may cause vibration and premature wear on the disk. The gate valve may be used for shutoff service where a slow closure is acceptable and where an absolute bubbletight closure is not a critical consideration. Gate valves may be rising stem with outside screw and yoke (OS&Y), rising stem with inside screw, or non-rising stem. The rising stem type makes viewing of the valve position possible, while the non-rising stem type requires less clearance above the operator, since the stem does not rise from the body.

(b) Ball valves use a ball as the opening/closing mechanism to control fluid flow. The ball is rotated 90 degrees from full open to full closed; therefore, it is well-suited for applications which require quick or frequent opening and closing. The ball seals by fitting tightly against resilient seats located on each side of the ball. Ball valves are generally selected for on/off service and are most common in sizes 3 inches or less. Ball valves are available in three port sizes, including standard, full, and reduced port. Full port has the same opening size as the connecting pipe, standard port is usually one pipe size smaller than the valve size, and reduced port may be up to two pipe sizes smaller than the valve body size.

(c) Butterfly valves in the chilled water system are most common in the larger sizes due to the ease of operation, low cost, and superior shutoff characteristics. The butterfly valve usually consists of a wafer-shaped body with a rotating disk that closes against a resilient seat located within the valve body. Like the ball valve, a 90-degree rotation of the operating mechanism results in valve travel from closed to full open. The butterfly valve is well-suited for both on/off service or throttling service.

(d) Globe valves are primarily used for throttling service and are not well-suited for full flow applications due to the high resistance to flow designed into the valve. The standard valve consists of a round disk or tapered plug that seats against a round opening. Angle valves and needle valves are variations of the standard globe valve and use a similar method of closure. Unlike the gate and ball valves, globe valves must be installed in the proper direction of flow. Flow should enter through the disk seat and push up against the valve disk. Reverse installation will result in valve chatter, vibration, and premature valve failure.

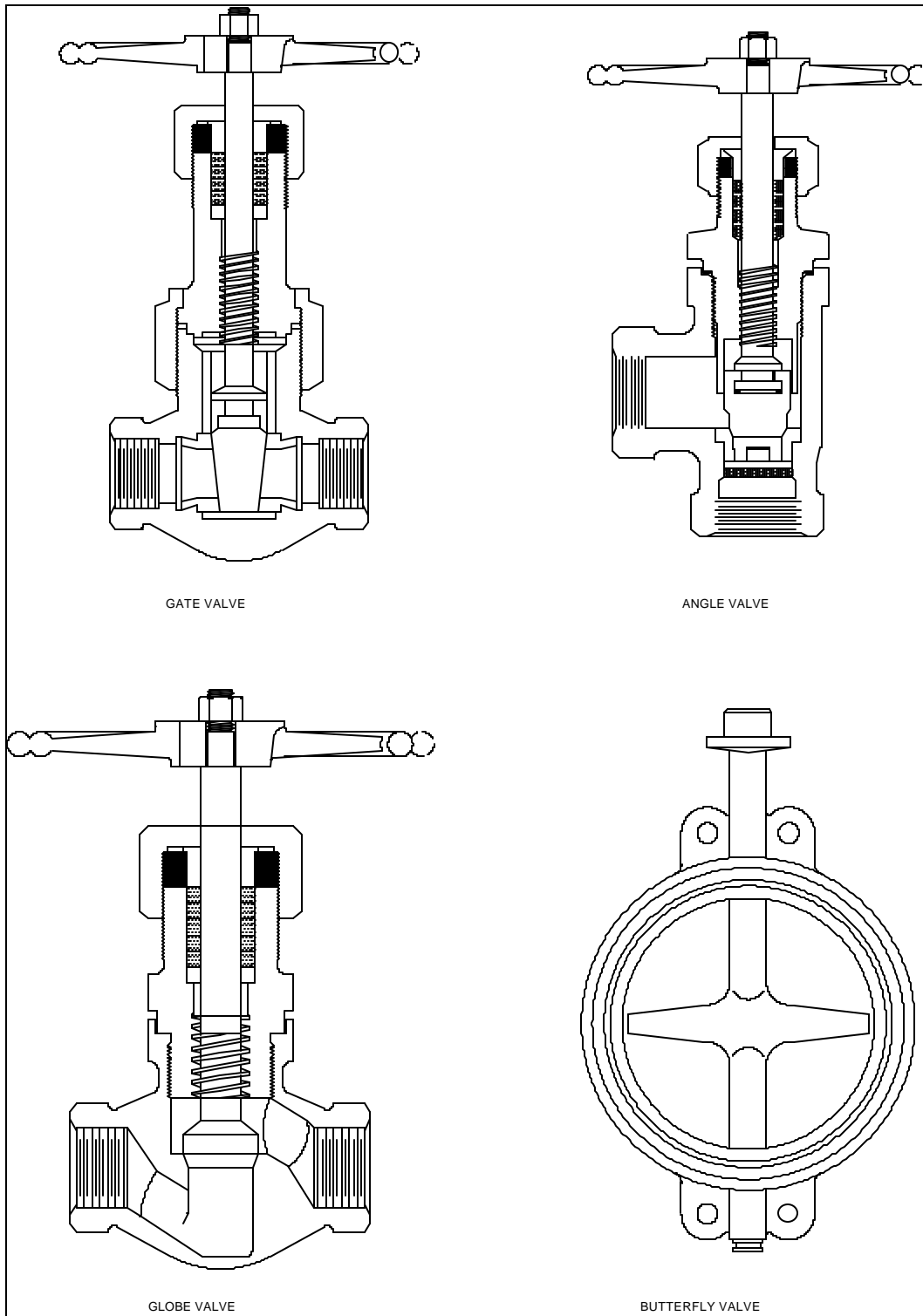

Figure 11-2. Typical valves used in water service(1)

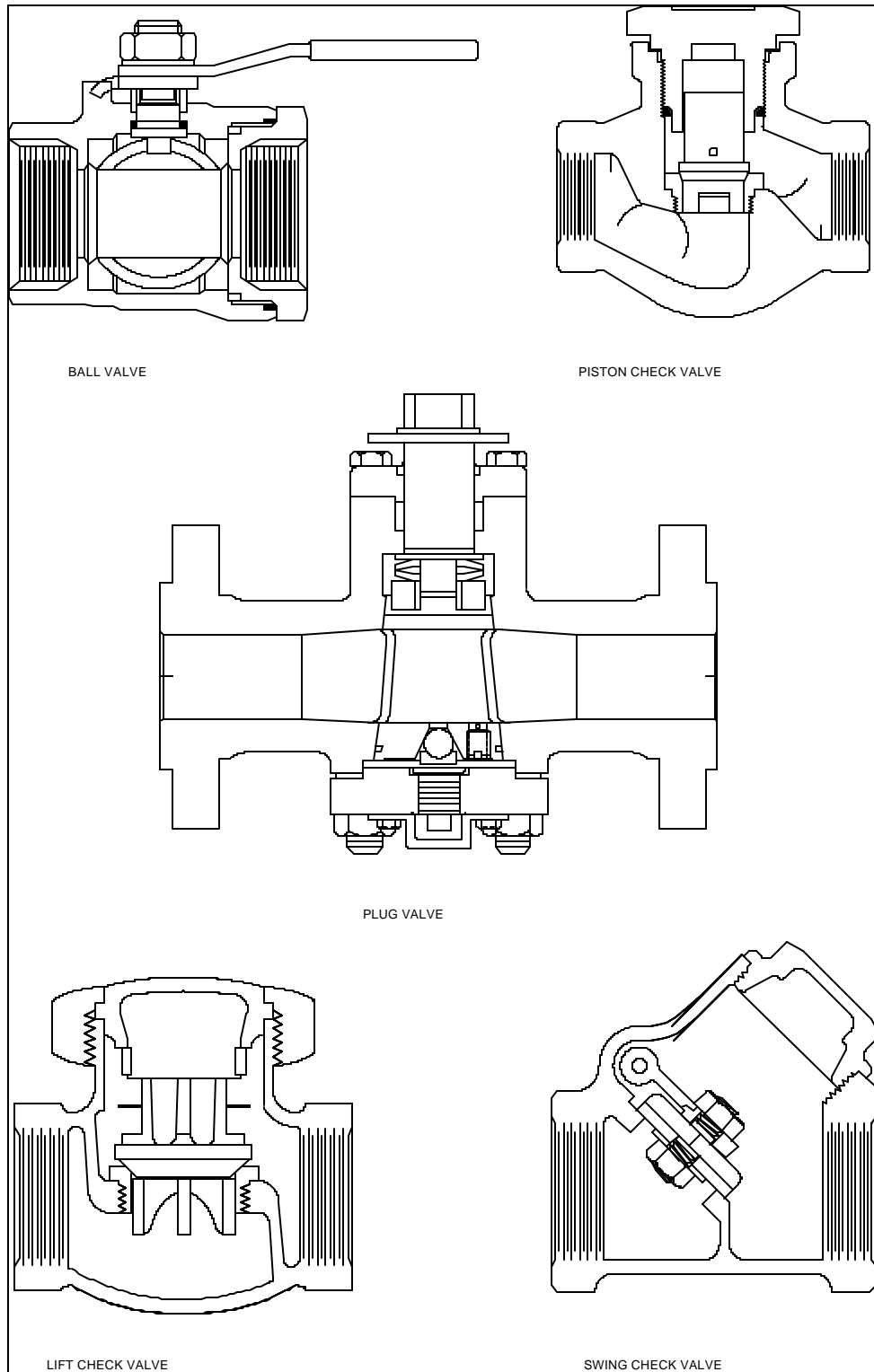

Figure 11-3. Typical valves used in water service(2)

(e) Check valves are used in the chilled water system to prevent reversal of flow at pumps and equipment, with swing checks and lift checks as the most common types. The swing check has a swinging disk that is held open by the fluid flow. Closure results from reverse flow and gravity acting on the disk. Lift check valves consist of a disk that is lifted by upward fluid flow. Reversal of flow pushes down on the disk, stopping flow. The swing check valve has less resistance to flow due to its straight-through flow design, but is more prone to water hammer than the lift check. Swing and lift check valves generally are only suited for horizontal installations, unless specifically configured for vertical installation.

(f) Water pressure regulating valves are used in the chilled water system to limit the water supply pressure to equipment within acceptable levels. The two common types of water pressure regulating valves include the direct-acting type and the pilot-operated type. The direct-acting regulator consists of an inner valve connected to a diaphragm. The diaphragm is held in position by a spring that is externally adjustable to give the desired downstream reduced pressure. The direct-acting regulating valve is simple and relatively inexpensive, but is not capable of maintaining constant downstream pressures if the upstream pressure varies or if the flow rate varies significantly. The pilot-operated regulator is more accurate than the direct-acting type, as it employs a small direct-acting valve (pilot valve) that maintains a constant pressure on the main valve diaphragm. Variations in upstream pressure have little effect on the resulting downstream pressure.

*k. Piping.* Piping 2 inches and smaller used in chilled water systems is typically standard weight, continuous weld steel pipe with threaded joints and cast iron fittings. In addition, Type L hard copper pipe can be used in this size range. Copper piping uses soldered joints with wrought copper fittings. For chilled water piping larger than 2 inches, steel pipe conforming to American Society for Testing and Materials (ASTM) A 53, Standard Specification for Pipe, Steel, Black and Hot-Dipped, Zinc-Coated, Welded and Seamless (1999), is used. Joint types for this size of pipe are welded, flanged, or grooved. Fittings for ASTM A 53 pipe are wrought steel, cast iron, and malleable or ductile iron.



## CHAPTER 12

### DOMESTIC WATER SYSTEMS

---

#### 12-1. Domestic water system description

Domestic water (potable water) is water that is free from any significant impurities that would cause disease or harmful physiological effects to humans, and is in compliance with the water quality requirements of the Health Service having jurisdiction.

*a. System functions.* The purpose of the domestic water system is to provide the occupants of a facility an adequate quantity of domestic water for drinking and for the proper operation of plumbing fixtures utilized for personal health and hygiene. The domestic water system must also protect the water it conveys from harmful substances that would damage the water quality and make it unfit for human consumption. The domestic water system is comprised of a water supply; a water distribution system; auxiliary components such as water heaters, pumps, storage equipment, and backflow prevention devices; and the termination point of use that are the plumbing fixtures.

*b. Water supply.* The water supply may be from a public or private onsite system. Public systems are generally very reliable, however, for critical facilities, the use of a private system in conjunction with a storage system or a private onsite water supply will ensure the availability of water at all times.

(1) An example of a typical domestic water system with reservoir storage (under normal operation) is shown on figure 12-1. In this arrangement, under normal conditions, the plumbing fixtures are supplied with water directly from the public water supply. The public water supply is metered and then distributed throughout the facility. The supply of water to equipment and uses that may contaminate the domestic system is provided through a backflow preventer. The water downstream of the backflow preventer is referred to as nonpotable, and is not for human consumption.

(2) During periods when the public water system is out of service, water is drawn from the reservoir and supplied to the facility through the use of the reservoir pump (emergency operation). The pump is controlled by a pressure switch, and system pressure is maintained by the hydropneumatic tank as the pump cycles. Check valves in the system prevent water flow back into the public system when the reservoir pump is operating and prevent backflow through the pump when it is not operating. The reservoir is kept filled with water when operating from the public system; however, the reservoir water must be pumped out and refilled on a regular basis to prevent stagnation and contamination of the stored water.

#### 12-2. Domestic water system major components

Domestic water systems are generally comprised of the following major components.

*a. Water storage.* Water storage systems may be associated with a private water system in which case the storage would act as a buffer to maintain a relatively constant supply pressure. Water storage systems also may function as an emergency backup supply in the event that the public water supply is taken out of service. The principle types of water storage are tanks, reservoirs, and bladder tanks. All storage structures utilized for domestic water must be constructed of nontoxic materials that resist corrosion, and must be disinfected prior to use.

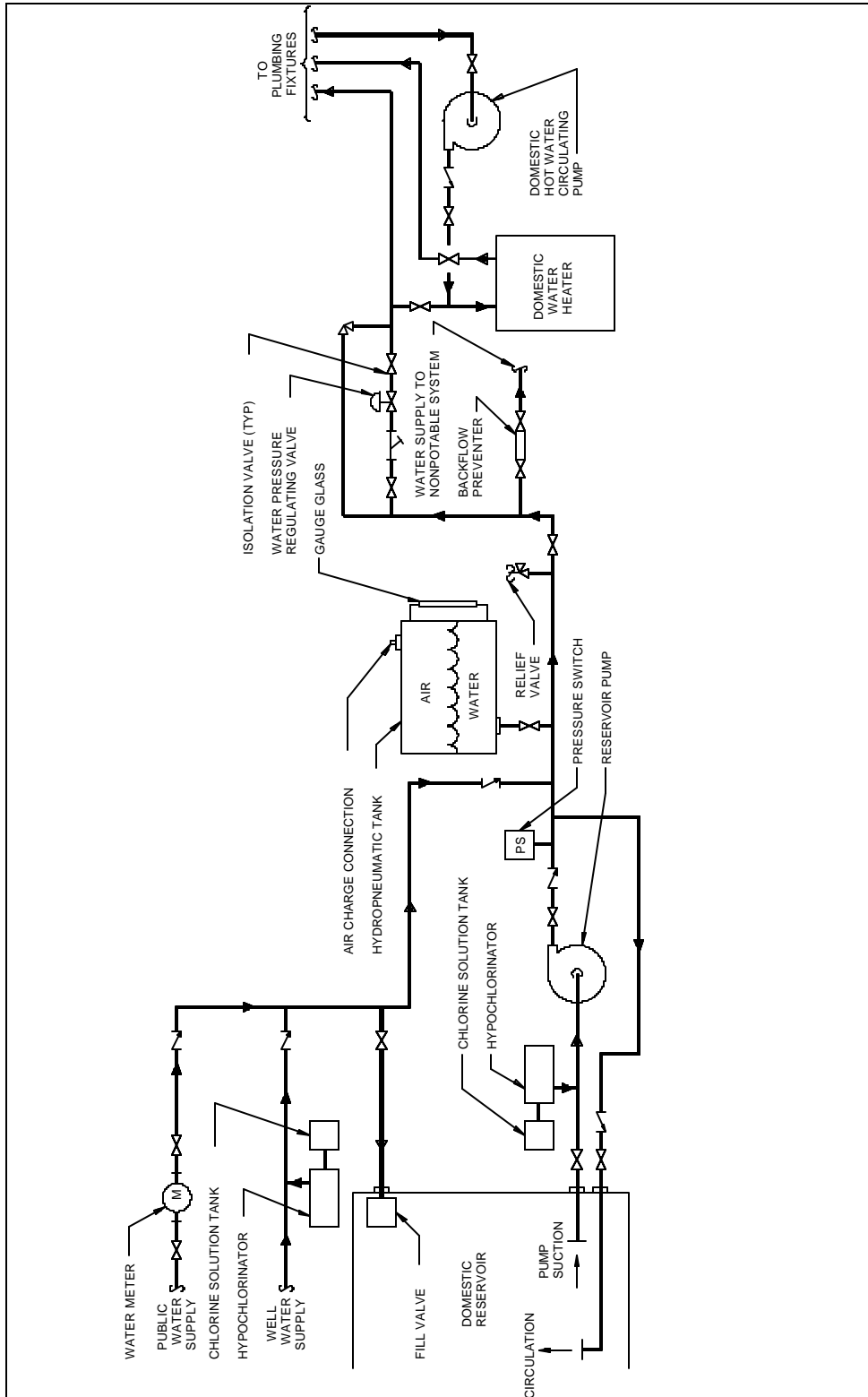

Figure 12-1. Domestic water system with reservoir storage

(1) The discussion will focus on two types of aboveground tanks: ground-mounted and elevated. The elevated storage tank is used in flat-land areas where the terrain does not offer the advantage of a high point near the water use point in which a ground-mounted tank could be located. The elevated storage tank consists of a tank (usually steel), structural support legs, and water standpipe. The ground-mounted tanks are also usually constructed of steel, and are typically mounted on a concrete foundation. The pump and piping arrangement serving the storage tanks is dependent on the tank elevation. If the tank is well above the water use point (60 to 100 feet), the water supply is pumped into the tank to maintain a certain water level, and the tank is not pressurized. The water pressure at the use point is equivalent to the water elevation in the tank (100 feet = 43 psig). If the water storage tank is at or near the same elevation of the use point, the tank is usually pressurized if it is used as a constant water supply system. If the tank is used for emergency purposes only, it may have pumps on the discharge and then would not be pressurized.

(2) Reservoirs are typically underground concrete water storage structures. Typically the reservoir is not pressurized and is fed from a private or public water system, or in some cases may be spring fed. It is common for pumps to draw from the reservoir and pump into the pressurized water system at a facility. Reservoirs typically have an access for maintenance personnel and a vent to prevent pressure buildup.

(3) Bladder tanks, also referred to as hydropneumatic tanks, consist of a steel tank that is divided into an air section and a water section by a rubber bladder. The air section is charged with air to a pressure equivalent to the minimum desired pressure in the water supply system. A bladder tank is commonly installed on a private water supply system to provide some storage capacity and to act as a buffer for the supply pumps (figure 12-2). Typically, one third of the total tank capacity is available for storage (a 200 gallon tank would result in 70 gallons of useful storage).

*b. Water heaters.* The purpose of the domestic water heater is to provide hot water at the desired temperature to the plumbing fixtures and to any other point of use. System water temperatures range from 120 to 140°F for typical plumbing fixtures, up to 165°F for laundry, and 180 to 190°F for dishwashing and sanitizing applications (see figures 12-3, 12-4, and 12-5).

(1) Heat energy sources include oil, propane and natural gas, electricity, and steam. Oil and gas units are generally referred to as fuel type direct-fired water heaters. Electric water heaters employ a direct conversion of electrical energy into heat. Indirect water heating is accomplished through the use of remote heat sources (usually boilers) which supply steam to the water heater. The water heater then uses steam as an energy source to heat the domestic water.

(2) Water heaters are also classified as to their storage capacity and recovery rate. The recovery rate is the amount of water in gallons per hour (gph) that can be raised +100° F at a given heat input. The storage capacity allows large volumes of hot water to be drawn from the system at flow rates that exceed the recovery capacity of the heater. Instantaneous heaters have a high recovery rate and very little storage, while storage type heaters have a lower recovery rate and significant storage capacity. A semi-instantaneous heater is a variation of the above two types, with limited storage and moderate recovery rates.

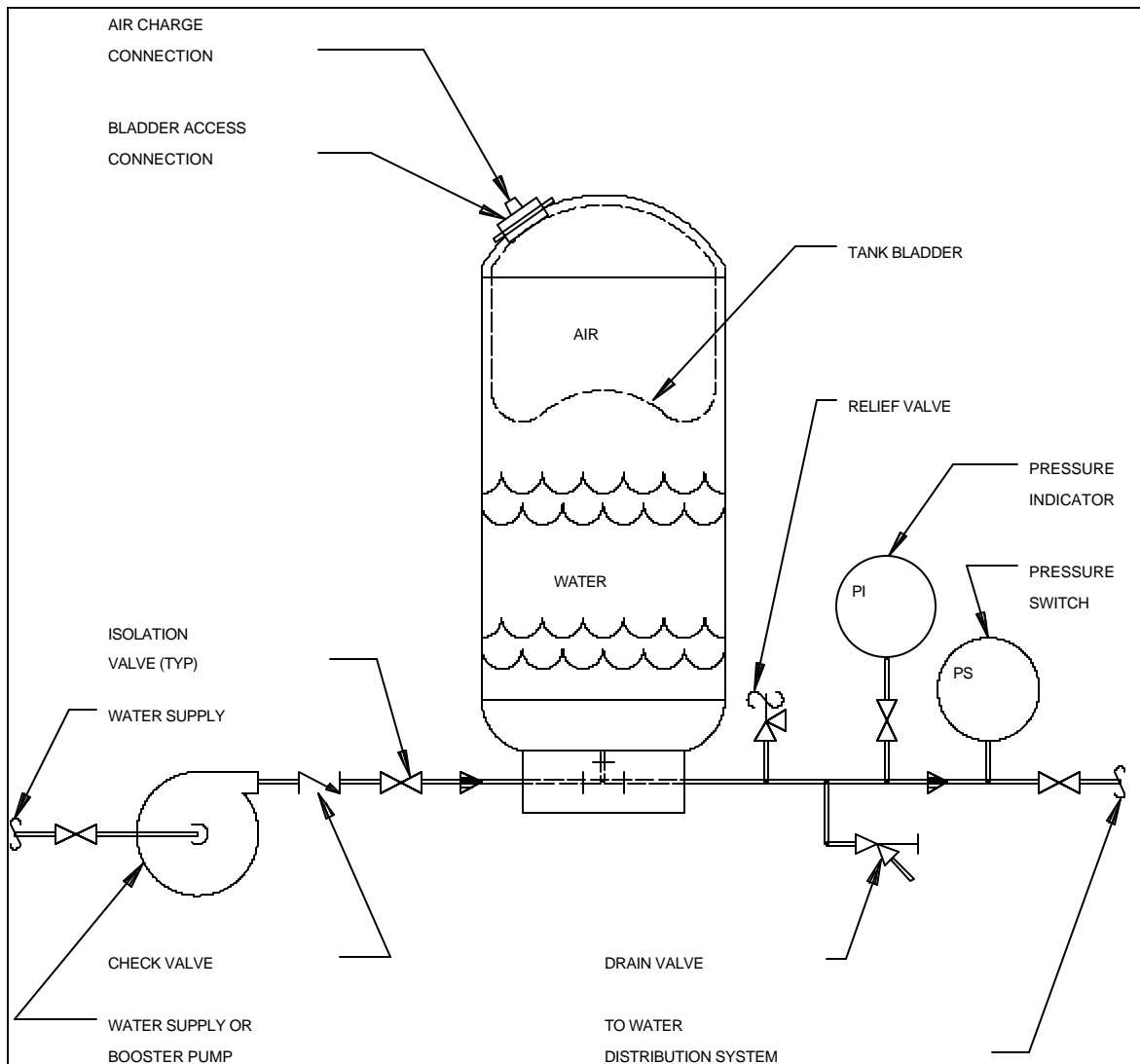

Figure 12-2. Bladder tank installation

c. *Plumbing fixtures.* The plumbing fixture is the termination point of the domestic water system and is the beginning of the sewer system. Since the quantity of water consumed by the plumbing fixture presents a load on both the domestic water supply system and the sewage disposal/treatment system, all plumbing fixtures should be maintained to minimize water usage. All plumbing fixtures should be provided with shutoff valves on the water supply to allow for servicing. The most common plumbing fixtures are water closets, urinals, lavatories, service sinks, general purpose sinks, and drinking fountains.

d. *Backflow preventers.* Backflow preventers are devices used to prevent the contamination of the domestic (potable) water system. Backflow preventers can be classified into four basic types, with the proper application of each type dependent upon the piping arrangement and the degree of hazard involved. The basic types of backflow preventers are illustrated on figure 12-6.

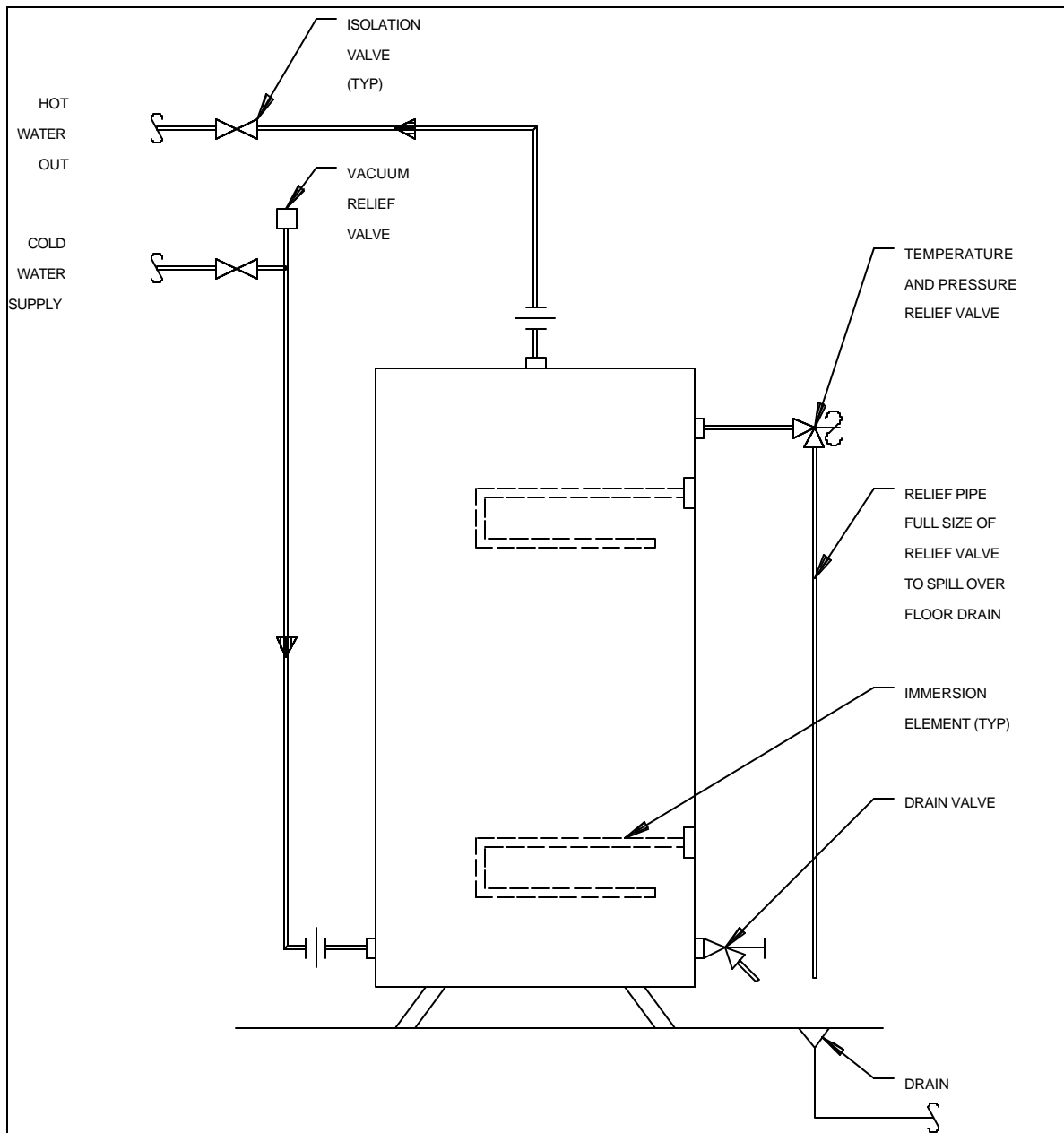

Figure 12-3. Electric water heater

e. *Valves and piping.* A variety of valves and piping materials are commonly used in domestic water systems.

(1) Valves installed in the domestic water system are to control water flow and to isolate equipment for ease of operation and maintenance. Most valves in a domestic water system are manually operated with a handwheel or lever operator.

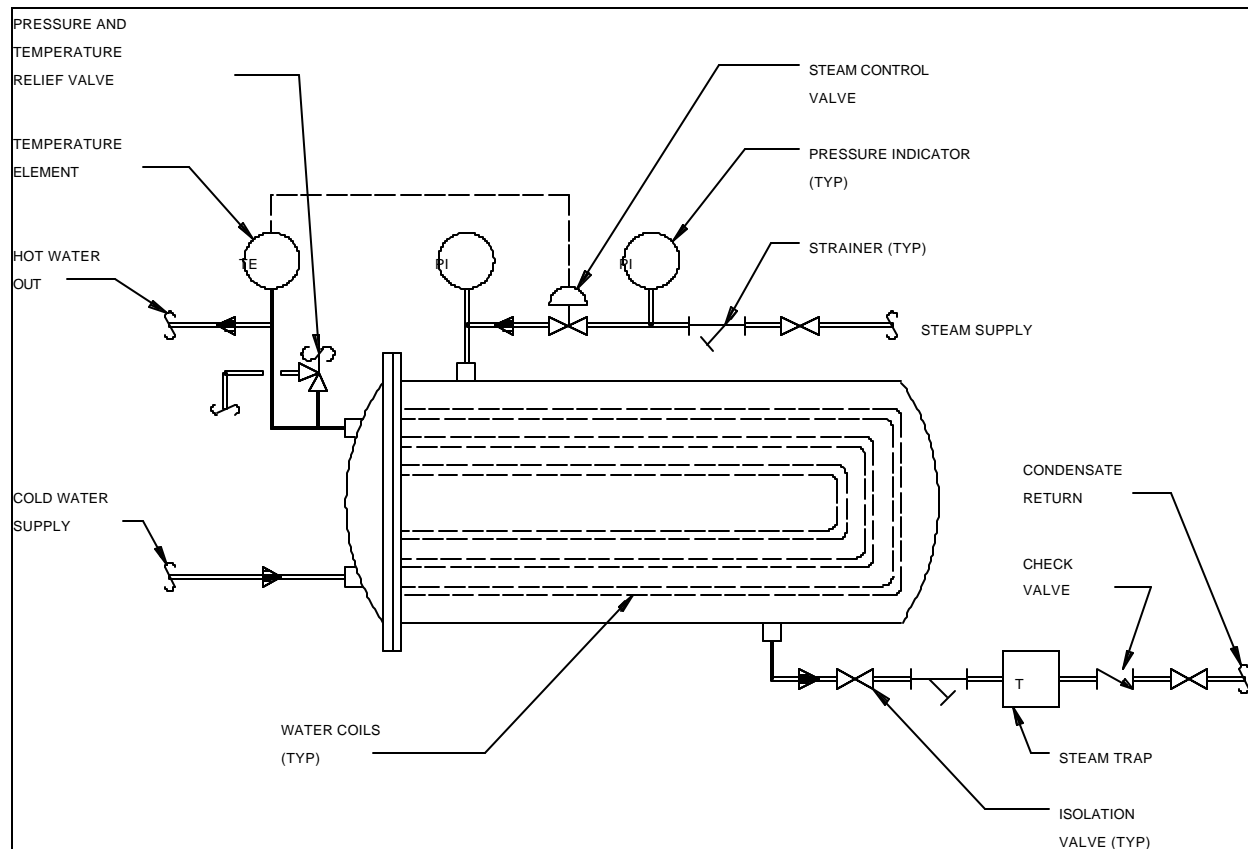

Figure 12-4. Instantaneous steam water heater

(2) Piping materials that convey domestic water must be specifically approved for this use. Typical code-approved piping materials for water distribution include brass pipe, copper tube or copper pipe, galvanized steel pipe, ductile iron pipe, and approved plastic pipe. Pipe and fittings for use in domestic water systems shall not contain more than 8 percent lead. Solder used for joining copper tubing shall not contain more than 0.2 percent lead.

(a) Piping systems should be inspected and tested prior to being concealed and put in service. Minimum test pressure should be 80 psig or the working pressure, whichever is greater. A visual inspection should be made to identify proper installation, including joints and connections, supports, access to valves, and cross connections. Pipelines should be identified as to the fluid contained by color coding or identification tags. An adequate quantity of unions or flanges should be provided at all pieces of equipment to allow for servicing of the equipment. Drain valves should be installed at low points of the piping system to facilitate draining of the system for maintenance. Installation of pipe over electrical equipment should be avoided or should be provided with drip pans.

(b) Brass pipe is an alloy of copper and zinc and is found on a limited basis in domestic water systems. The most common use is for gauge piping and for piping of equipment accessories. Available sizes range from 1/8 inch up to 12 inch. Smaller diameter fittings are usually screwed whereas larger diameter fittings are flanged type.

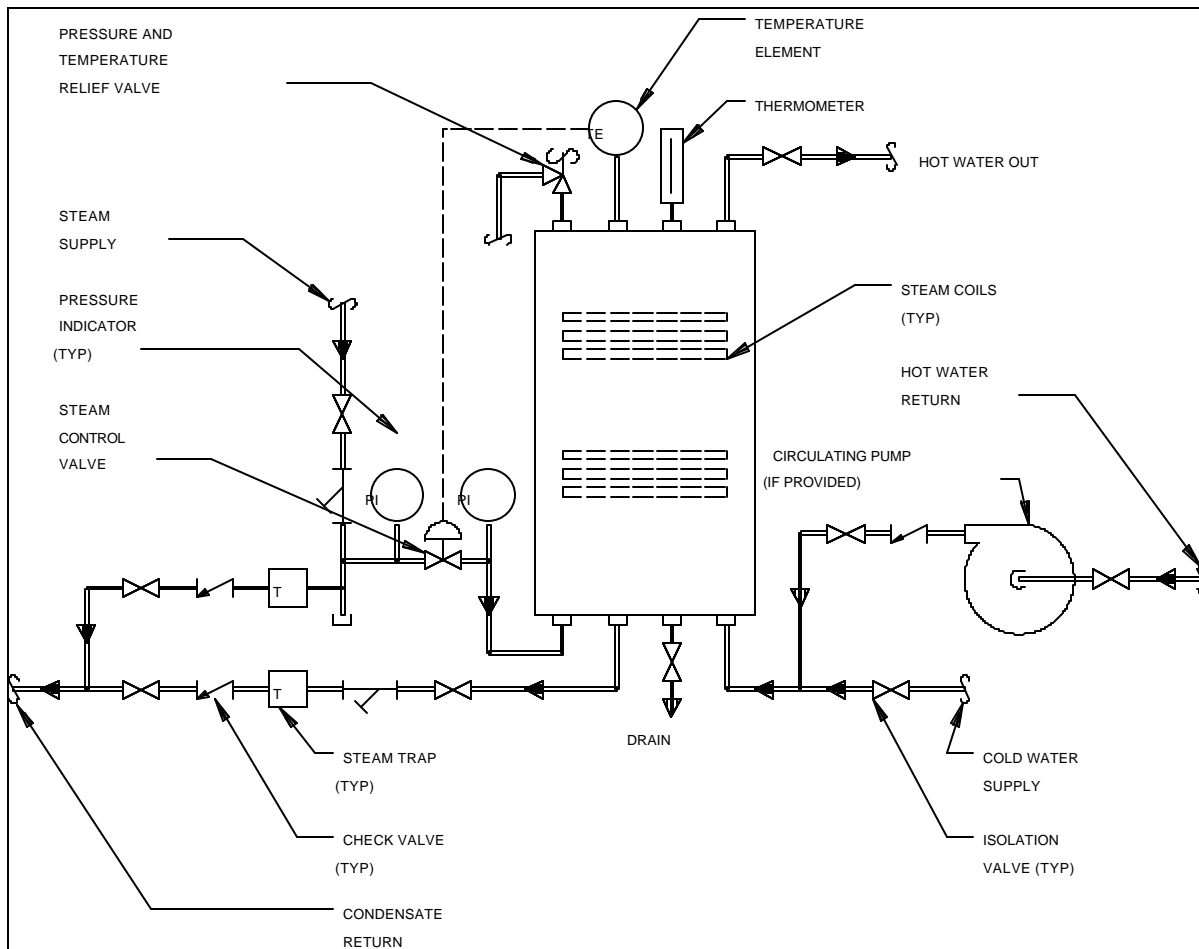

Figure 12-5. Semi-instantaneous steam water heater

(c) Copper pipe and tubing is common in domestic water service and distribution systems. Copper pipe is used on a limited basis for applications similar to that of brass pipe. Copper tubing, however, is used extensively for water service and distribution, especially in pipe sizes 3 inch and smaller. Copper water tube is designated as Type K, L, or M, and is available in drawn (hard) or annealed (soft) tempers in sizes from 1/8 to 12 inch. Copper tubing is also color-coded with a stripe to designate Type K (green), Type L (blue), or Type M (red). Type K tube is the heaviest of the three types and is used primarily for underground water services. Type L tube is used widely for underground water services and for interior water distribution piping. Type M tube is the lightest weight of the three tube types. Type M tube is approved for interior water distribution, however, it is preferable to use the heavier Type L tube for this application.

(d) Galvanized steel pipe is available in three basic weight categories including standard weight, extra-strong, and double extra-strong. American Society for Testing and Materials (ASTM) A 53, Standard Specification for Pipe, Steel, Black and Hot-Dipped, Zinc-Coated, Welded and Seamless, Grade B, standard weight (Schedule 40) galvanized steel pipe is the most common type of steel pipe used for domestic water application. Fittings are generally malleable-iron and threaded. Galvanized steel domestic water systems require more maintenance than non-ferrous systems due to the deterioration of the zinc-coating (galvanizing) and the natural oxidation of the steel over the lifetime of the system.

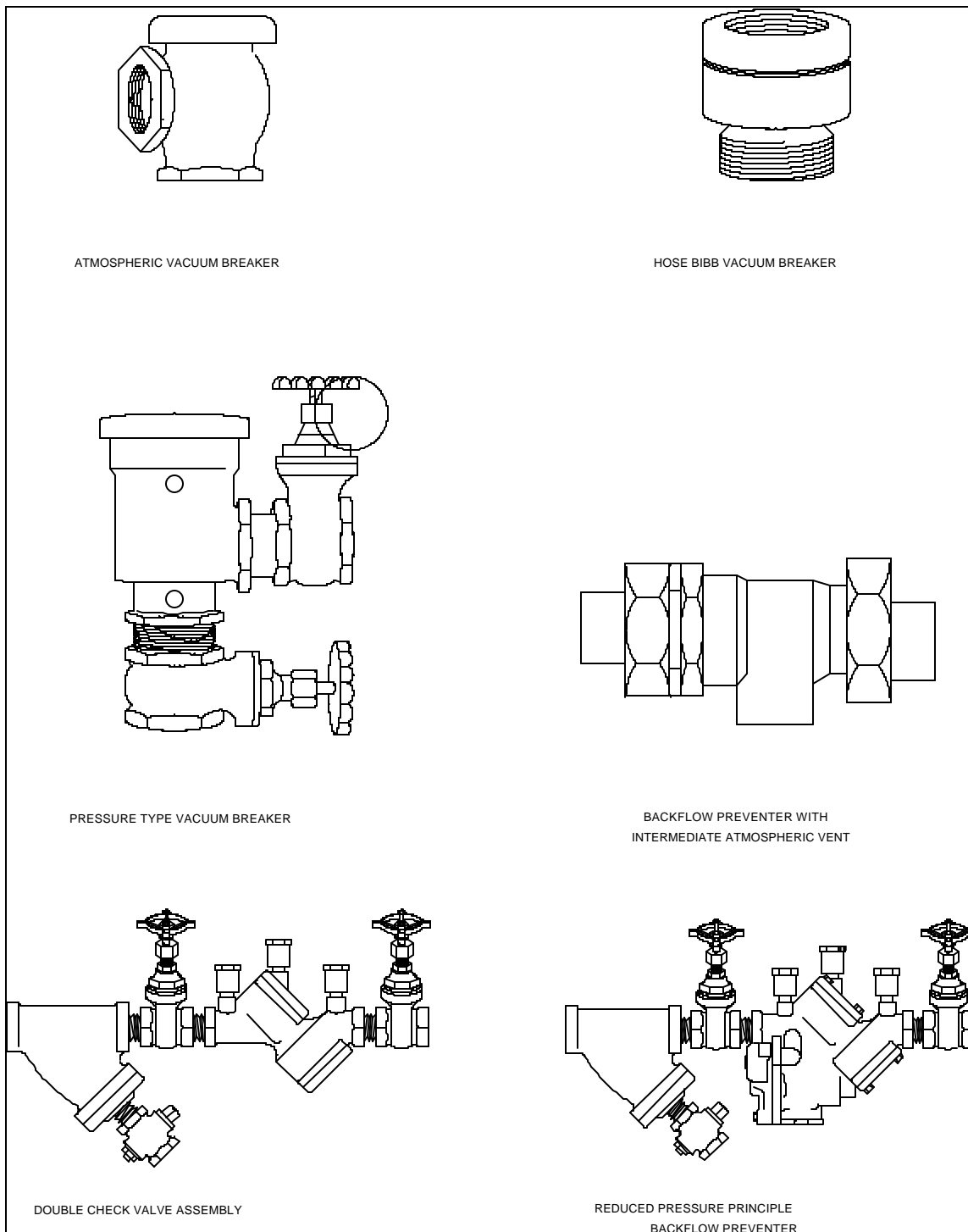

Figure 12-6. Backflow preventers

(e) Ductile iron pipe is typically used for underground water services and for water distribution in pipe sizes of 4 inch and larger. Fittings are generally push-joint for underground applications and flanged or mechanical joint for aboveground applications. Ductile iron pipe and fittings for domestic water systems must be cement mortar lined per the requirements of the American Water Works Association (AWWA) C104, Cement-Mortar Lining for Ductile-Iron Pipe and Fittings for Water (1995).



(f) Plastic pipe is available in various types, some of which are approved for domestic water services and others which are approved for domestic water distribution. Generally polybutylene (PB), polyvinyl chloride (PVC), and polyethylene (PE) are approved for underground water services, whereas interior water distribution systems are limited to chlorinated polyvinyl chloride (CPVC) and PB pipe and tubing. PVC and CPVC fittings are available in solvent weld, threaded, and flanged types. PB and PE fittings are available in thermal fusion and compression types. Metal insert fittings are also available for PB pipe. Plastic pipe has excellent characteristics for resistance to corrosion, therefore, it is well-suited for corrosive atmospheres or for use in soils where corrosion protection would be required for metallic piping systems. An interior plastic water distribution system will require considerably more pipe supports than a metallic system due to the poorer strength characteristics of plastic. Also, the combustion qualities of plastic pipe prevent its use in some building areas, including spaces used as air plenums.

f. *Pumps.* Pumps are most commonly used in domestic water systems for boosting water pressure and for hot water circulation. There are two basic types of pumps: positive displacement and centrifugal.

g. *Water treatment equipment.* Water treatment equipment generally associated with domestic water systems includes hypochlorinators and water softeners. Hypochlorinators are used to disinfect well water and water reservoirs, whereas water softeners are used to remove dissolved solids from the water supply.

## CHAPTER 13

### CHEMICAL TREATMENT

---

#### 13-1. Chemical treatment system design features

This chapter presents an overview of common chemical treatment processes that may be required to maintain water, steam, and condensate utility systems in good operating condition. The descriptions in this chapter are provided as a reference for the reader in applying the terminology, uses of equipment, and recommended maintenance practices. The need for chemical treatment depends on the quality of the water supplied to the facility and the types of equipment in service at the facility. There is no one treatment program or system that is right for all facilities or systems within the facilities. The chemical treatment examples are based on the facility being supplied with water either from a municipal supply system or from a well system dedicated to the facility. The water supplied to the facility generally meets drinking water standards and is used to supply potable water and process water systems within the facility.

*a. Applications.* The systems for which treatment practices are discussed as follows.

- (1) Well water delivered to facility domestic and industrial water reservoirs
- (2) Closed-loop recirculating water systems (chilled water, recirculating cooling water, and hot water heating)
- (3) Open recirculating water systems (cooling tower spray water or recirculating cooling water in an open cooling tower loop)
- (4) Steam boiler system (makeup water, feedwater, and steam and condensate)

*b. Water supply disinfection.* Although the water supplied to the facility is already drinking water quality, additional disinfection may be required to control the growth of biological contaminants, such as algae, in the potable and industrial water reservoirs where long-term storage may provide conditions for growth. This additional disinfection may be direct treatment of the water supplied to the facility, treatment of a recirculating stream at the reservoirs, or a combination of both. Operator involvement is limited to testing the water to determine the amount of treatment required, adjusting the pump stroke and/or the hypochlorite solution strength to obtain the desired dosage, and keeping an adequate supply of hypochlorite solution in the local storage tank.

*c. Process water systems.* Process water refers to systems, such as chilled water systems, hot water heating systems, and recirculating water equipment cooling systems. The three primary reasons that process water chemical treatment may be required are to control corrosion, scale formation, and the growth of biological agents. Because corrosion and scale control chemicals can change the pH of the circulating water stream, the pH of a system may also require monitoring and adjustment. Process water streams may be closed-loop systems or open systems.

(1) In closed loop systems, there are negligible losses from or additions into a known volume system. Once the initial volume is chemically treated, the quality of the circulating fluid needs to be monitored on a regular basis and additional chemicals added as required to maintain recommended residual

concentrations of treatment chemicals. When chemical treatment of a closed-loop water circulating system is required, the chemicals are usually introduced into the system by means of a pot feeder. The chemical treatment can be accomplished as the system is filled or during normal operation of the system using a pot feeder in a bypass loop. A typical pot feeder fill system installation is shown on figure 13-1, and a typical pot feeder bypass installation is shown on figure 13-2.

(a) In cold service closed-loop systems, the system may only need to have chemical treatment when the system is filled initially and any time the system has been open for maintenance. Cold service recirculating systems are usually treated to prevent corrosion from dissolved oxygen. Scale formation is usually not a problem in cold systems.

(b) In warm or hot service closed-loop water circulating systems, regular monitoring and chemical additions may be required to prevent corrosion from dissolved oxygen and scale formation from precipitation of minerals in the water.

(2) In open recirculating cooling water systems there is constant loss from the system due to evaporation and a constant addition of makeup water into the system which constantly changes the quality of the recirculating stream. Also, as water evaporates from the system, impurities in the water are left behind which causes an increase in the concentration of these impurities. These impurities are generally referred to as total dissolved solids. Open systems typically control total dissolved solids by blowdown from the system. Additionally, the methods used to reduce the temperature of open recirculating water streams allow oxygen, which is a primary cause of corrosion, to be entrained in the recirculating stream.

(a) This constant change in the system quality may require frequent water quality monitoring along with the frequent addition of chemicals to control corrosion, scale formation, and growth of biological agents. Some combinations of chemicals used may also change the pH of the system significantly which will require pH monitoring and adjustment. If an open system requires chemical treatment, treatment program options range from the operator periodically sampling the water and making slug additions of chemicals into the basin to a continuous water quality analyzer controlling the operation of metering pumps which inject controlled doses of chemicals into the circulating stream to maintain a uniform water quality.

(b) A typical automated open-loop water quality monitoring and control system is shown on figure 13-3. In the example automated system, a sample stream passes through a water quality analyzer which has probes that monitor pH and conductivity (a measure of total dissolved solids). The pH meter controls a metering pump that injects a pH adjustment solution (usually an acid) into the circulating stream. The conductivity meter controls the operation of the blowdown valve. A signal from a water meter in the makeup waterline controls the corrosion inhibitor metering pump. A timer in the water quality analyzer activates the biological growth control metering pump. Some automated systems may have a corrosion sensing probe, rather than a water meter, to control the corrosion inhibitor metering pump. A likely alternate to the fully automated system is metering pumps controlled by timers. Based on a periodic water sample, the operator sets the timers and adjusts the metering pumps to provide the desired level of chemical treatment for the system.

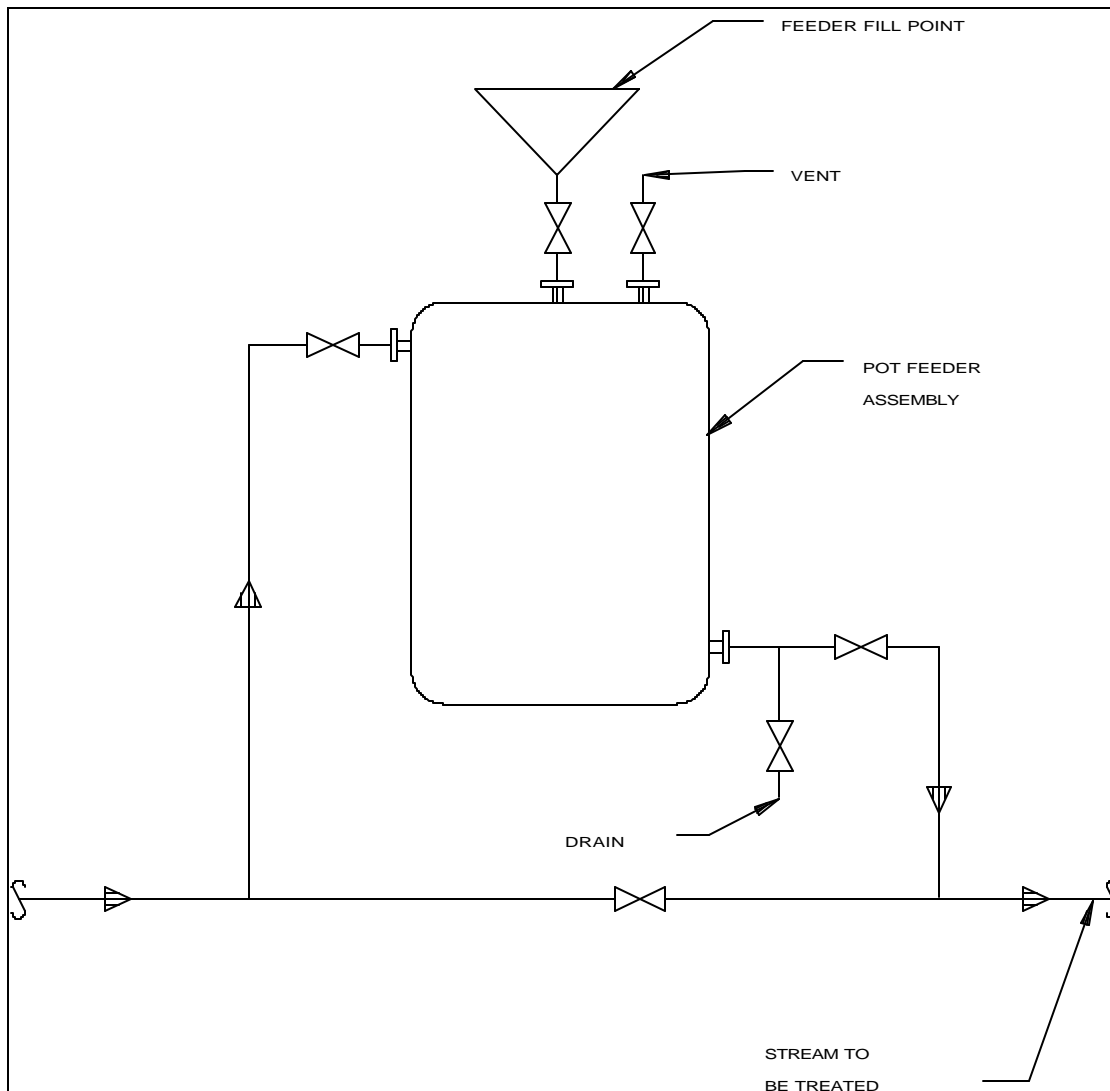

Figure 13-1. Typical fill system pot feeder installation

(3) The elevated temperatures at which even low-pressure boilers operate increase the likelihood of corrosion and scale formation problems from contaminants in the water. Other common boiler problems caused by poor water quality control are foaming and caustic embrittlement of metal components (usually not a concern for boilers operated below 600 psig). Steam boiler water quality control is typically accomplished by a combination of chemical treatment, deaeration, and blowdown. A typical steam boiler installation is shown on figure 13-4.

(a) In the example installation, the quality of the makeup water is adjusted by a water softener, a dealkalizer, or an ion exchange unit. In areas where only treatment to reduce hardness is required, a water softener is used to reduce the total dissolved solids in the makeup water that helps control scale formation and foaming. In areas where only treatment to reduce alkalinity is required, a dealkalizer is used. In areas where combined treatment is required, an ion exchange unit is

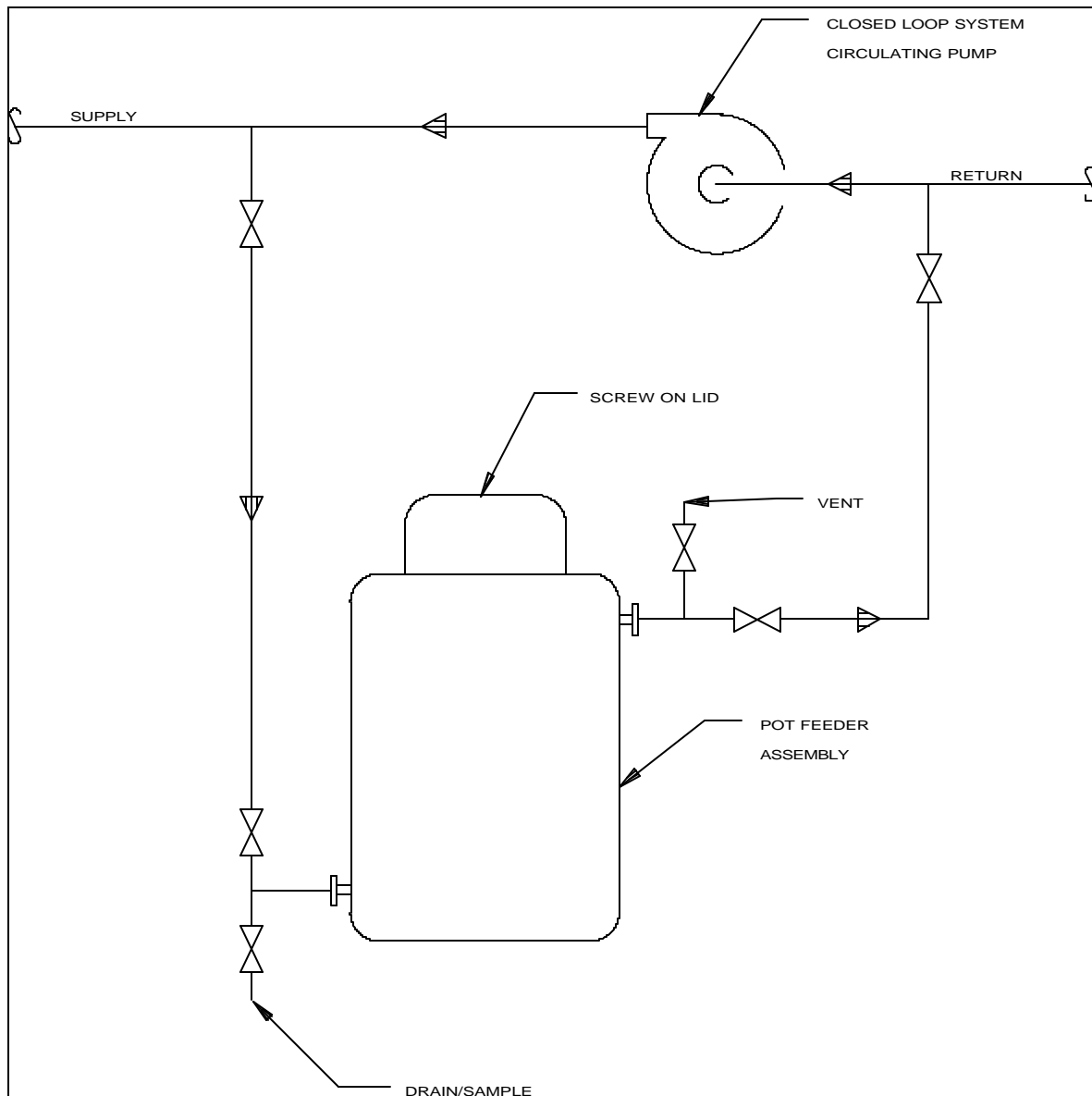

Figure 13-2. Typical pot feeder bypass installation

used. In an ion exchange unit, a section known as the cation exchanger removes metals, such as calcium and magnesium (hardness), and a section known as the anion exchanger (alkalinity control) may remove bicarbonates (corrosion and embrittlement), sulfates (hard scale), chlorides (foaming), and soluble silica (hard scale). A typical water softener unit is shown on figure 13-5, and a typical ion exchange unit is shown on figure 13-6. Dealkalizer units operate the same as water softeners, but use different resin bed materials and require strong caustic or acid regeneration. The makeup water is passed through a treated resin bed where the contaminants in the water are collected through a chemical exchange process. When the bed becomes saturated with contaminants, the bed is backwashed, treated with a concentrated electrolyte, rinsed, and placed back in service. For critical or continuous operations, treatment units may be dual-column units that allow switching from a saturated column to a regenerated standby column so

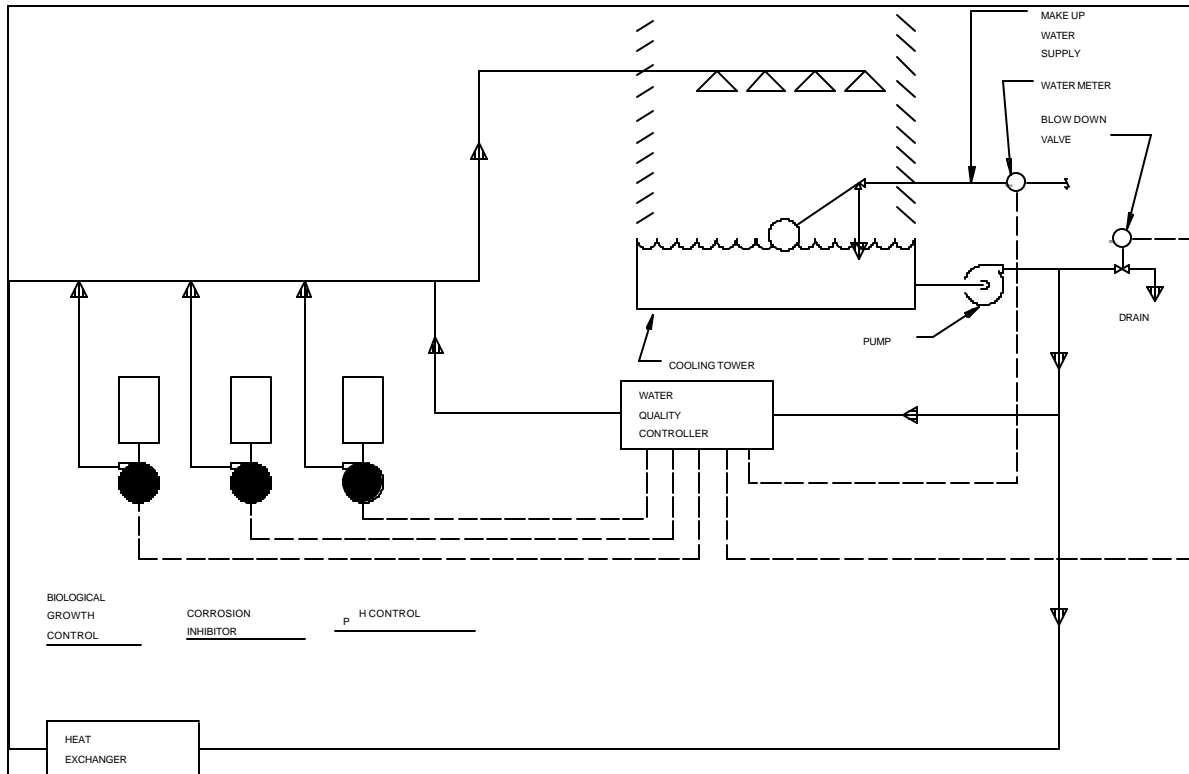

Figure 13-3. Open-loop chemical treatment system

that service is not interrupted for routine column regeneration. Ion exchange units may also be used to provide water for engine cooling systems and closed-loop process water systems. The use of water softener-treated water for engine cooling loops is discouraged by many engine manufacturers.

(b) The next step in boiler water quality control is deaeration of the combined makeup water and condensate return stream. A deaerator unit heats the water to the boiler point at the operating pressure of the unit which encourages release of non-condensable dissolved gases, such as oxygen and carbon dioxide, which are significant contributors to corrosion in the boiler and condensate system. As the feedwater flows from the deaerator to the boiler, various chemicals may be injected into the feedwater to further control corrosion, scale formation, foaming, and caustic embrittlement. (Some systems, as shown in the example, may also inject treatment chemicals into the steam header.) A typical feedwater treatment system consists of a chemical feed tank, an agitator, a strainer, a chemical feed pump, a check valve, and appropriate isolation valves. The operation and control of the metering pumps is dependent on the type of boiler and the boiler operation cycle, and the control options are similar to those discussed for open systems in paragraph 13-1c(2). Treatment chemicals such as hydrazine and sodium sulfite, are used to control corrosion by reacting with dissolved oxygen and are generally referred to as oxygen scavengers. Chemicals known as neutralizing amines (injected into the feedwater) and filming amines (injected into the steam lines) provide protection against carbonic acid formed by the reaction of carbon dioxide and carbonates. Scale control chemicals generally act to keep precipitated solids soft and fluid.

(c) As water evaporates to form steam, contaminants are left behind which increase the concentration of total dissolved solids in the boiler. Even if fluid, a coating of solids on heat transfer

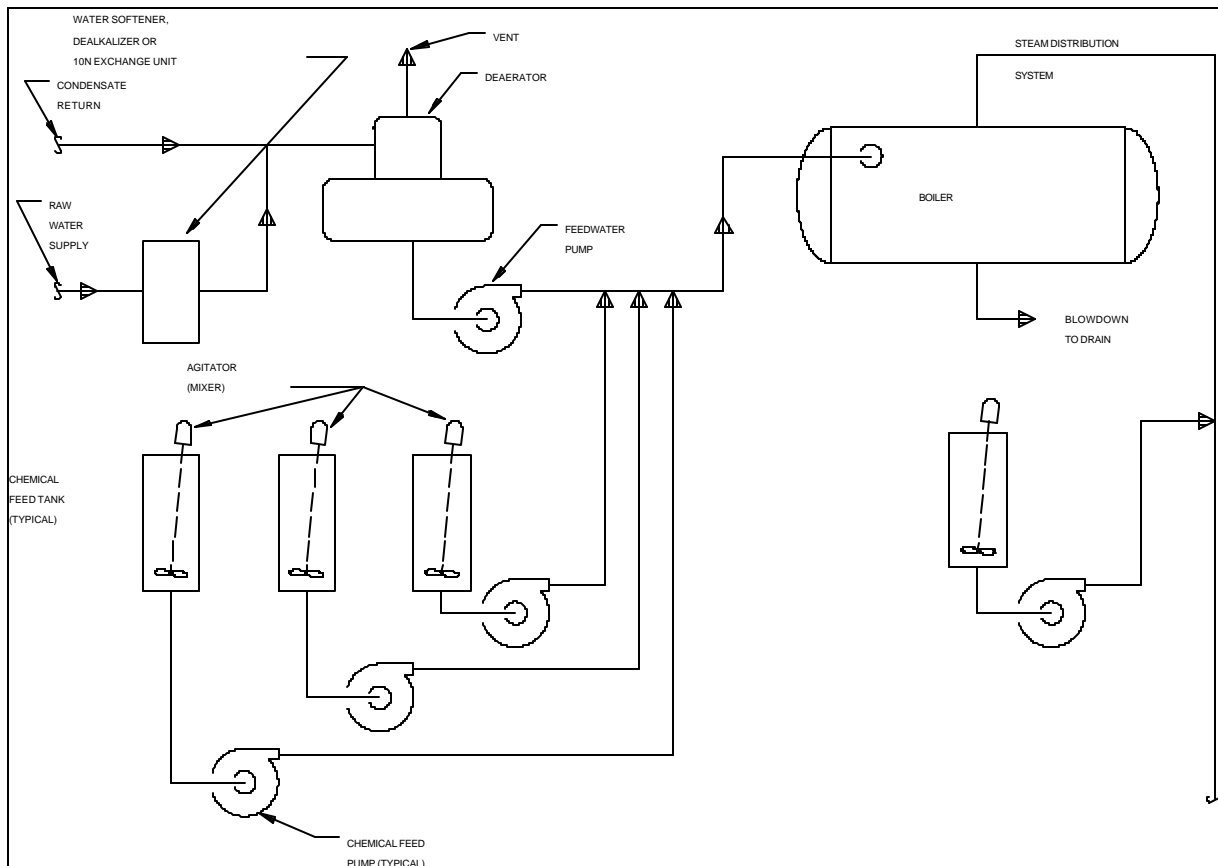

Figure 13-4. Typical steam boiler installation

surfaces, can reduce the capacity of equipment or create conditions which may lead to equipment failure. The concentration of total dissolved solids is controlled by blowing down the boiler. Boiler blowdown may be a combination of bottom blowdown and surface blowdown. Many boilers utilize a continuous or automated surface blowdown. Hot water boilers, which are used to provide hot water consumed in facility operations and, therefore, require substantial quantities of makeup water, may have makeup and feedwater treatment needs and blowdown operations similar to similarly sized steam boilers.

### 13-2. Chemical treatment system major components

Chemical treatment systems are comprised of the following major components.

*a. Chemicals.* The list that follows includes generic or families of chemicals which may be used to condition water and the typical condition that the chemical is used to treat. The specific name of the treatment product containing the listed chemical and the form of the chemical used will depend on the manufacturer. Most chemical treatment manufacturers have developed proprietary "brand names" which combine a number of the chemicals discussed below and include other agents to enhance the performance of the product. Facilities should use the technical service departments of water treatment chemical suppliers to tailor the facilities' chemical treatment needs to local conditions, and to establish procedures for safe chemical storage and handling.

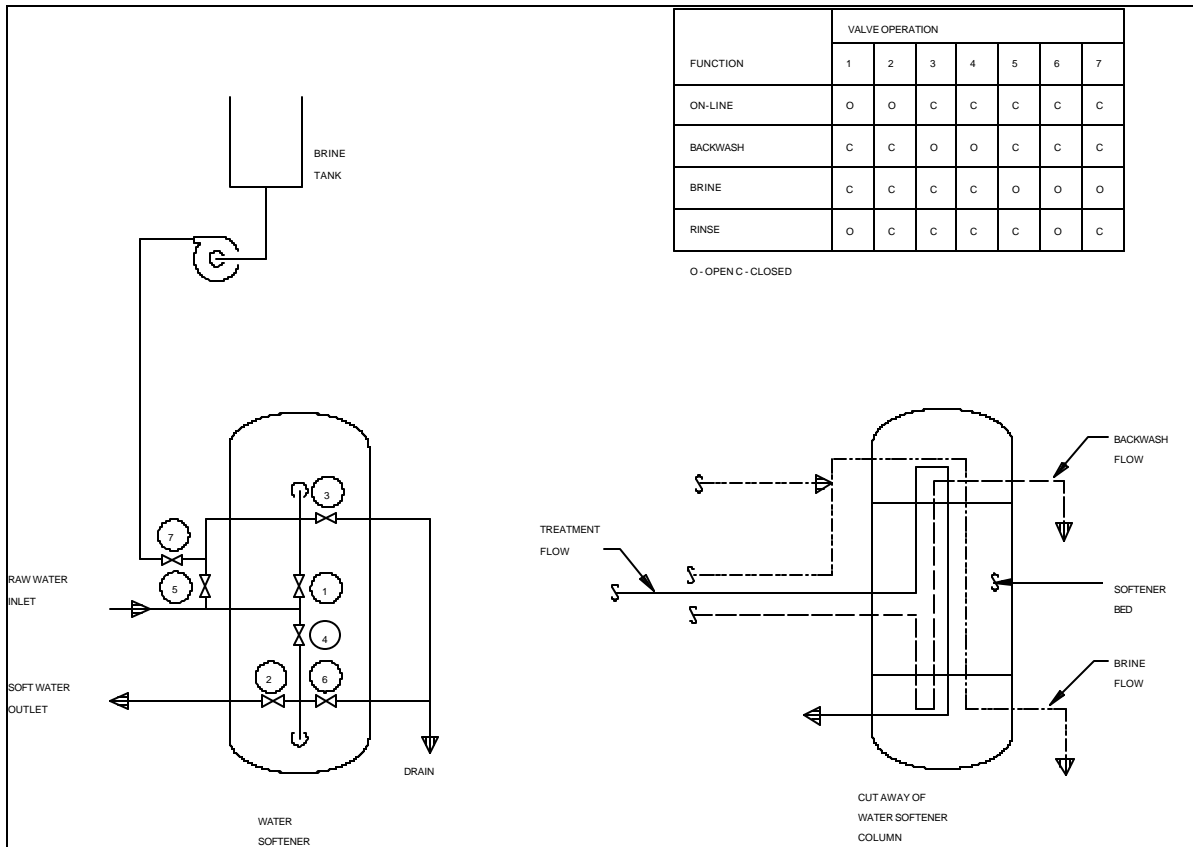

Figure 13-5. Basic water softener system

- (1) Copper sulfate - Controls algae in reservoirs and open systems.
- (2) Sodium hydroxide (NaOH - caustic soda) - Increases alkalinity, raises pH, precipitates magnesium.
- (3) Sodium carbonate (Na<sub>2</sub>CO<sub>3</sub> - soda ash) - Increases alkalinity and pH, precipitates calcium in the form of carbonate.
- (4) Sodium phosphates (NaH<sub>2</sub>PO<sub>4</sub>, Na<sub>2</sub>HPO<sub>4</sub>, Na<sub>3</sub>PO<sub>4</sub>, NaPO<sub>3</sub>) - Precipitates calcium as hydroxyapatite (Ca<sub>10</sub>(OH)<sub>2</sub>(PO<sub>4</sub>)<sub>6</sub>). Stream pH must be kept high for this reaction to occur.
- (5) Sodium aluminate (NaAl<sub>2</sub>O<sub>4</sub>) - Precipitates calcium and magnesium.
- (6) Chelants (EDTA, NTA) - Control scaling by forming heat-stable soluble complexes with calcium and magnesium.
- (7) Polymers (polyacrylates, etc.) - Disperse sludge and distort crystal structure of calcium deposits. Prevent fouling due to corrosion products.
- (8) Tannins, starches, glucose, and lignin derivatives - Prevent feed line deposits by coating scale crystals to produce a sludge that will not readily adhere to boiler surfaces.



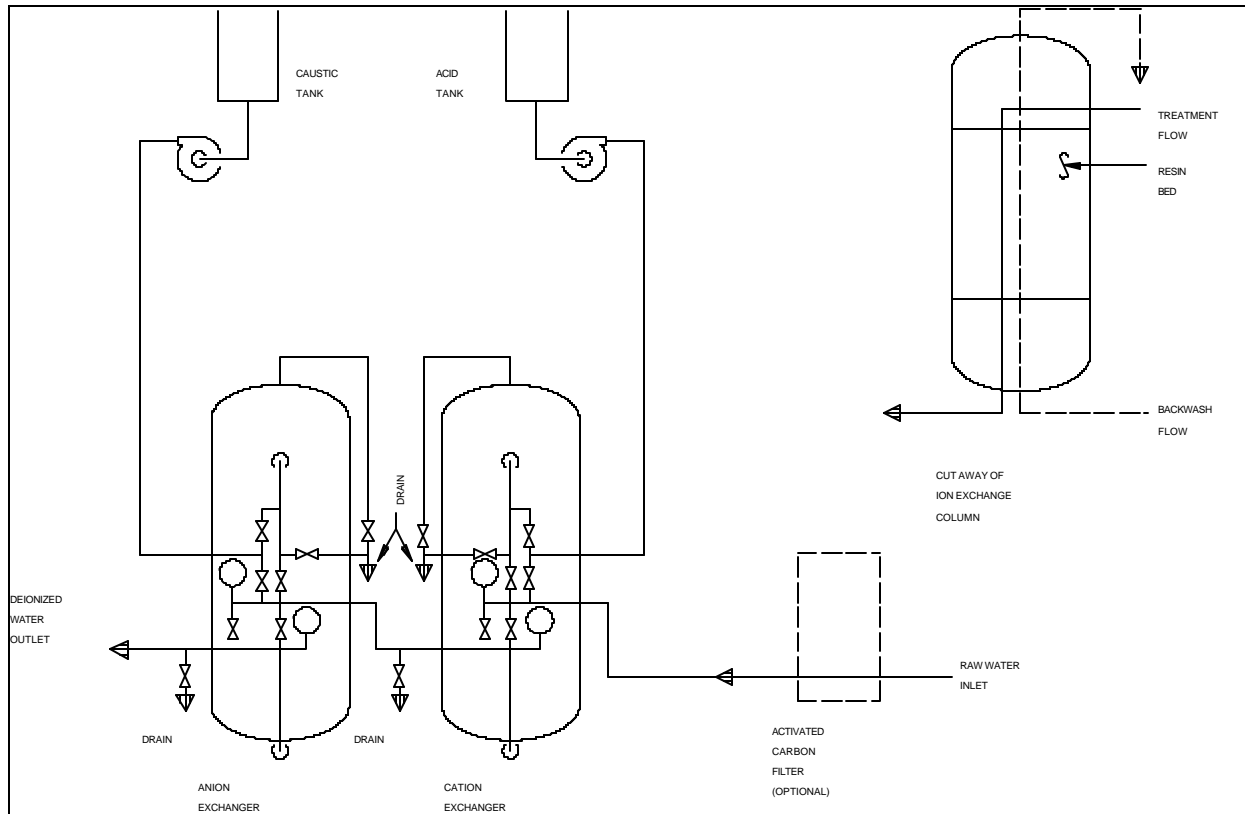

Figure 13-6. Basic ion exchange unit

(9) Seaweed derivatives (sodium alginate, sodium mannuronate) - Minimize carry-over from boiler by keeping scale forming sludge fluid.

(10) Sodium sulfite ( $\text{Na}_2\text{SO}_3$ ) - Prevents oxygen corrosion.

(11) Hydrazine ( $\text{N}_2\text{H}_4$  - normally supplied as a liquid) - Prevents oxygen corrosion.

(12) Filming amines (octadecylamine, etc.) - Control condensate line corrosion by forming protective film on metal surfaces.

(13) Neutralizing amines (cyclohexylamine, morpholine, etc.) - Control condensate line corrosion by adjusting condensate pH.

(14) Sodium nitrate ( $\text{NaNO}_3$ ) - Inhibits caustic corrosion.

(15) Antifoams (polyglycols, polyamides, silicones) - Reduce foaming tendency of highly concentrated boiler water.

(16) Nitrite-borax (three parts sodium nitrite and one part borax) - Inhibits corrosion and controls cylinder line cavitation in diesel engine cooling systems.

(17) Soluble oils - Inhibit corrosion in diesel engine cooling systems.

(18) Chromates - Inhibit corrosion in diesel engine cooling systems. Not compatible with ethylene

glycol base, antifreeze solutions. Extremely toxic. Do not use without major command permission.

*b. Chemical feed pumps.* Most chemical feed pumps are referred to as metering pumps. Because the pump has to inject a treatment chemical into what is frequently a high pressure stream, common chemical feed pumps are positive displacement units which use a reciprocating (piston) action to alternately fill a pumping chamber and discharge a fixed volume of solution. In many units, the piston acts through a flexible, noncorrosive diaphragm that isolates the mechanical elements of the pump from the chemical stream. Chemical metering pump discharge quantities can usually be varied by adjusting the stroke length of the pump by means of an external stroke length adjustment knob. The stroke adjustment of many electric motor-driven metering pumps alters a mechanical linkage that can be damaged if the pump is not operating when adjustments to stroke length are made.

*c. Pot feeders.* Pot feeders are used to add chemicals to systems that do not require frequent chemical treatment. The flow of the stream or part of the stream to be treated through a pot feeder charged with chemical solutions adds the chemical to the stream. Typical pot feeder installations are shown on figures 13-2 and 13-3.

*d. Valves and piping.* This paragraph presents an overview of the types of piping components and design and testing considerations related to chemical treatment piping. Information contained in this section applies to field-installed piping. Piping design, materials, fabrication, assembly, erection, inspection, and pressure tests for facility piping systems should be in accordance with American Society of Mechanical Engineers (ASME) B31.1, Power Piping. Major modifications of existing piping systems should include hydrostatic testing, and radiographic or magnetic particle inspection of welds where applicable. During testing, system components that have not been designed for the piping test pressure must be disconnected and protected against damage by overpressure.

(1) Common valve materials compatible with typical facility chemical treatment systems are carbon or stainless steel. Valve bodies from these materials should be cast or forged. In low-pressure systems, plastic valves from materials similar to polyvinyl chloride (PVC) may be used. In general, unless the valve has failed after only a short period of use, replace valves (and other piping components) with new valves constructed from the same materials. Typical types of valves that may be found in chemical treatment systems are as follows.

(a) Gate valves may be used for lube oil shutoff service where a slow closure is acceptable and where absolute bubbletight closure is not a critical consideration. Gate valves may be rising stem, outside stem and yoke (OS&Y), or double-disk type.

(b) Ball or non-lubricated plug valves are generally used where quick or frequent opening or closing is required.

(c) Check valves are used in chemical treatment systems to prevent backflow through pumps, branch lines, meters, or other locations where runback or reverse flow must be avoided.

(d) Globe valves are used in systems at locations where manual control of the flow rate is required. General use of globe valves should be avoided, because of their high resistance to flow.

(2) Common piping materials used in chemical treatment systems are carbon steel pipe, and stainless steel pipe and tubing. Some low-pressure systems may use plastic pipe components. In general, when modifying or repairing a system, replace existing piping components or add to the system using

pipng components of the same materials of construction of the existing system, provided the service life has been good.

(3) Many piping systems will have one or more pipe test sections installed in the system. A test section is a short section of pipe that can be easily isolated and removed from the system to make a thorough visual inspection of the interior of the pipe system possible. Visual inspection confirms the need for or the effectiveness of a chemical treatment program.

## CHAPTER 14

### AIR HANDLING SYSTEMS

---

#### 14-1. Air handling system design features

An air handling system is a means of providing conditioned air to the space in order to maintain the environmental requirements. Not all air handling systems will contain the components presented in this chapter, nor is there a standard arrangement for the devices and equipment for various facilities. While there is no "one correct way" to design an air handling system, all air handling systems have basic components that are used. To meet the whole sensible and latent cooling needs of a space with the cool air they supply, these systems use air handling units and, in most cases, chilled water coils to give cooled and dehumidified air to the space. These systems may use low-, medium-, or high-pressure air distribution systems. All air systems are subdivided into single-zone, multizone, dual-duct, reheat, and variable air volume systems.

*a. Single-zone systems.* Single-zone systems serve just one temperature control zone and are the simplest type of all air systems. For this type of system to work properly, the load must be uniform all through the space, or else there may be a large temperature variation. Single-zone systems are, in most cases, controlled by varying the quantity of chilled water or refrigerant, adding reheat, adjusting face or bypass dampers, or a combination of these. If a close control of the humidity is required while in the cooling mode, a reheat system must be used. Figure 14-1 is the schematic for a typical single-zone central air handling system.

*b. Multizone systems.* Multizone systems are used to serve a small number of zones with just one central air handling unit. The air handling unit for multizone systems is made up of heating and cooling coils in parallel to get a hot deck and a cold deck. For the lowest energy use, hot and cold deck temperatures are, as a rule, automatically changed to meet the maximum zone heating (hot deck) and cooling (cold deck) needs. Zone thermostats control mixing dampers to give each zone the right supply temperature. A typical multizone air handling system is shown on figure 14-2.

*c. Dual-duct systems.* Dual-duct systems are much like multizone systems, but instead of mixing the hot and cold air at the air handling unit, the hot and cold air are both brought by ducts to each zone where they are then mixed to meet the needs of the zone. It is common for dual-duct systems to use high-pressure air distribution systems with the pressure reduced in the mixing box at each zone. A simple dual-duct system is shown on figure 14-3.

*d. Reheat systems.* Reheat systems supply cool air from a central air handler as required to meet the maximum cooling load in each zone. Each zone has a heater in its duct that reheats the supply air as needed to maintain space temperatures. Reheat systems are quite energy-inefficient and have become rare in new buildings as the cost of energy has gone up. Most reheat systems are constant volume, thus the reduction of air volume to each zone as the cooling load gets less will keep down the use of the reheat units and reduce energy consumption significantly. Energy may also be saved by automatically resetting the temperature of the cold air, allowing it to rise as the temperature of the outside air falls. More energy savings may be found through the recovery of the refrigeration system's rejected heat and the use of this heat to reheat the air. An example of a reheat system that uses terminal reheat units is shown on figure 14-4.

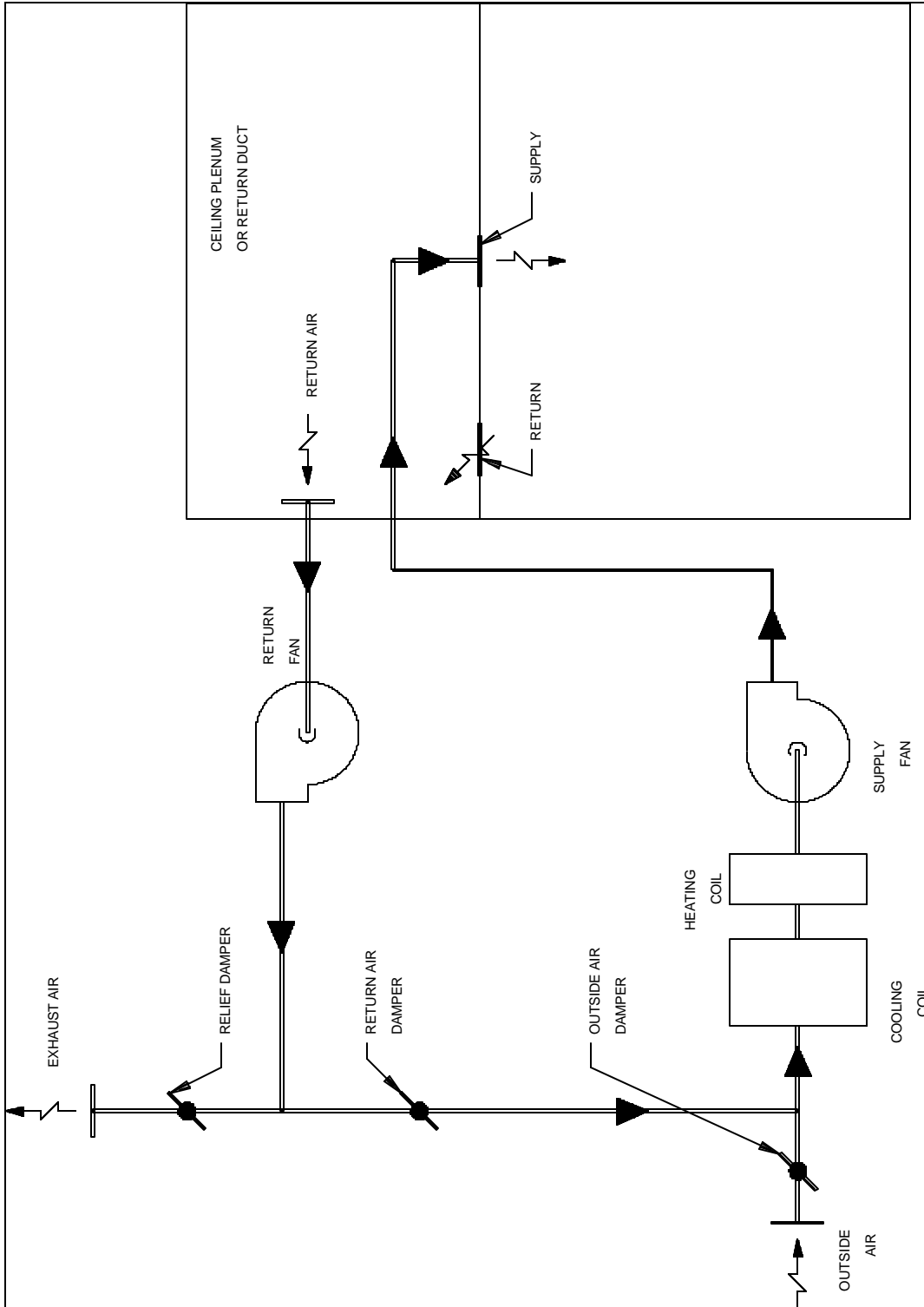

Figure 14-1. Typical single zone air handling system

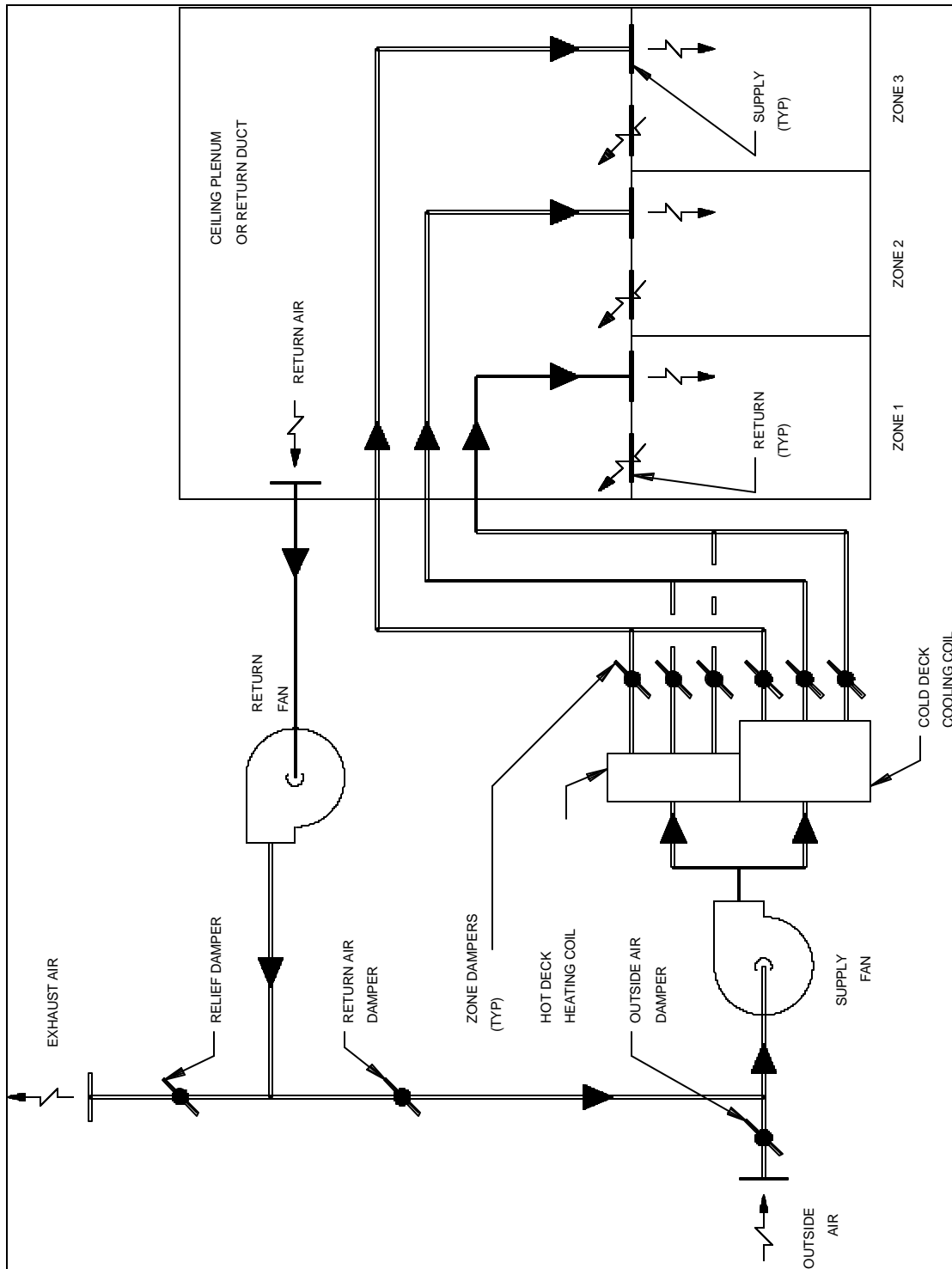

Figure 14-2. Multizone air handling system

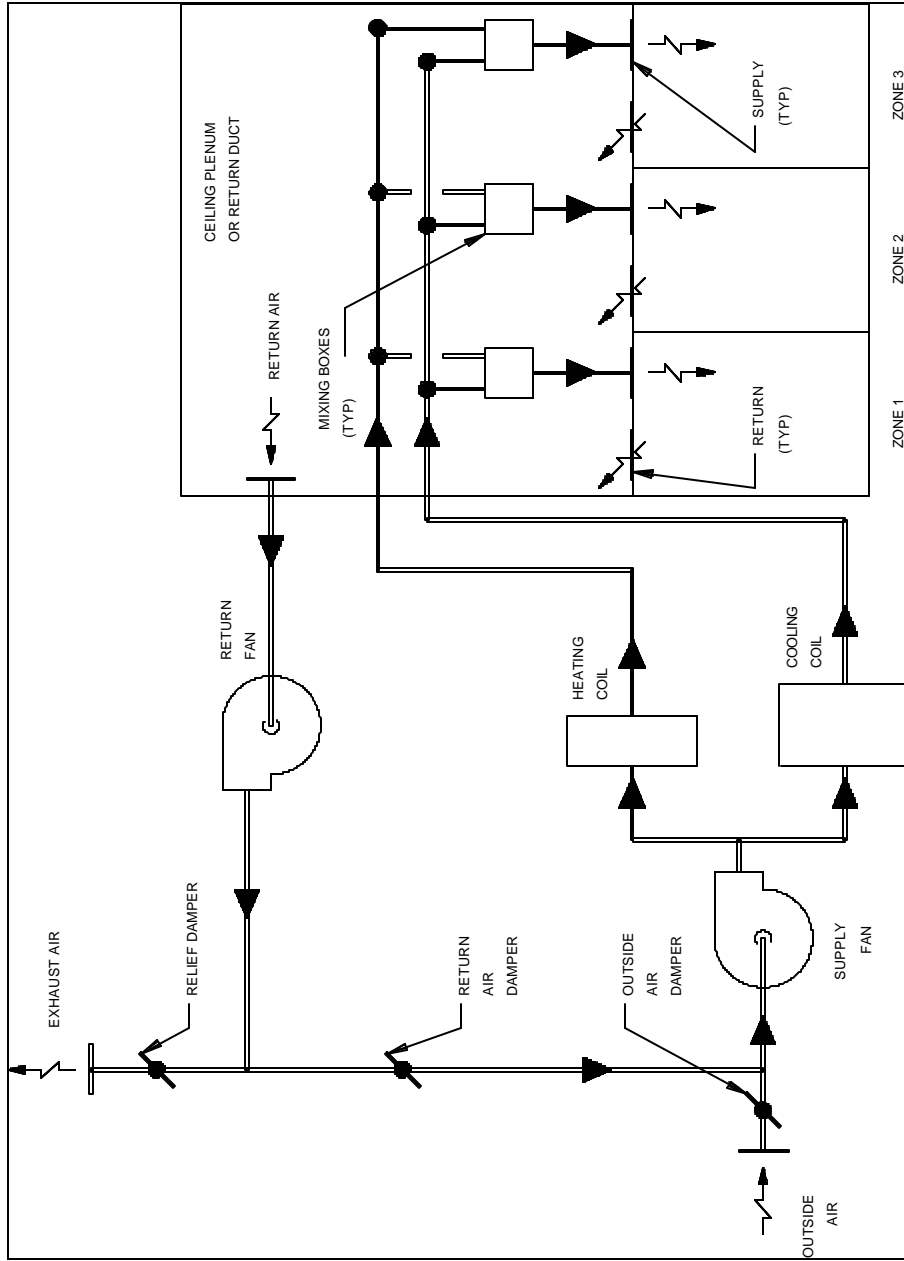

Figure 14-3. Basic dual duct air handling system

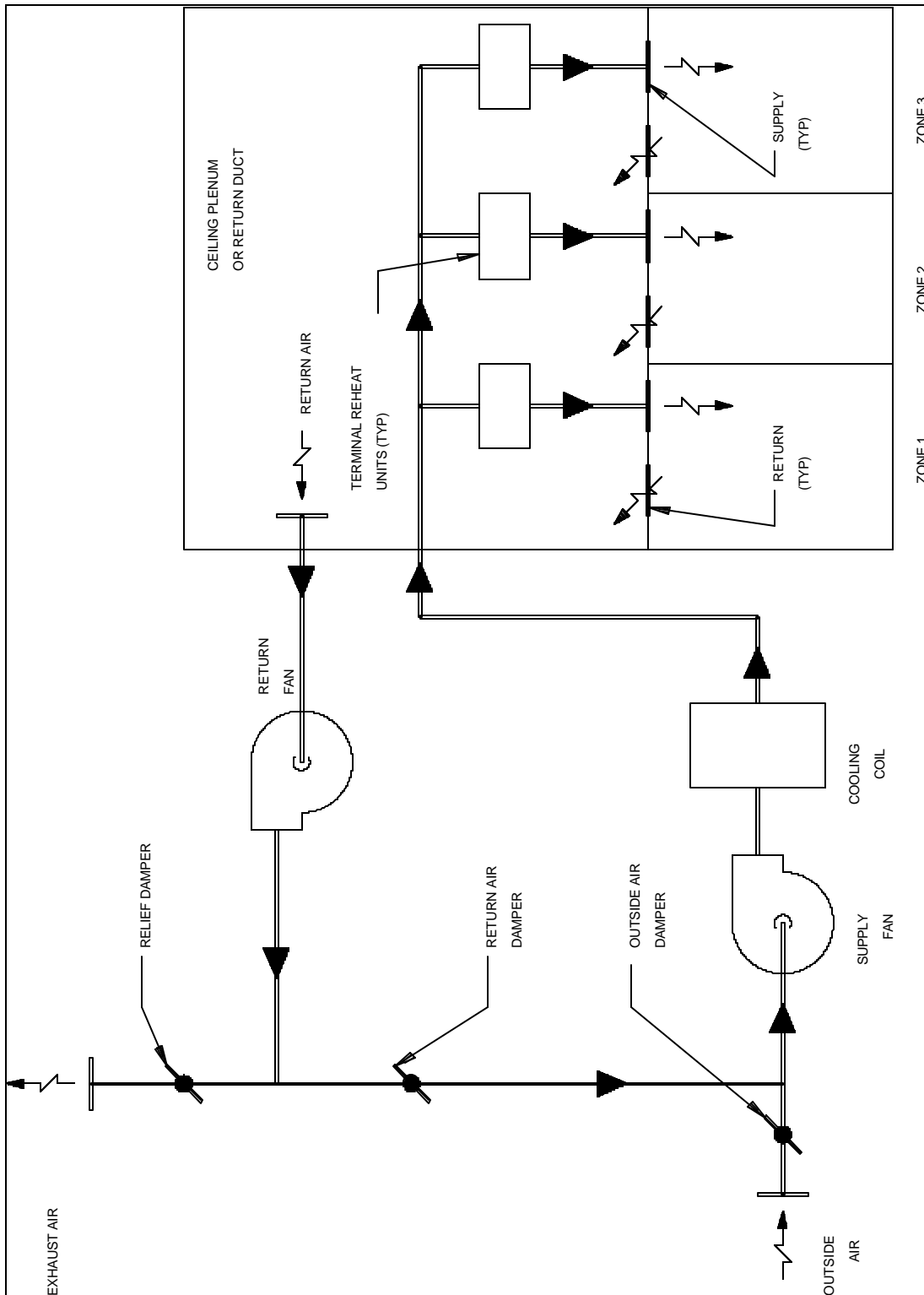

Figure 14-4. Air handling system with reheat



*e. Variable air volume systems.* The one feature that is common to all variable air volume systems is they change the volume of air in response to a change in load, rather than a change in the supply air temperature. Figure 14-5 shows a variable air volume, single-duct, multizone system. Variable air volume systems may change the volume of the whole airflow and/or the volume of each individual zone. Total system airflow may be varied by the use of inlet vanes, discharge dampers, speed control, and variable pitch blades. Zone airflow may be modulated in coordination with total system flow modulation or it may be varied by passing the excess flow right to the return air system with no variation in total system flow. Note that fan horsepower savings, which in most cases are found with variable air volume systems, are obtained from systems which modulate total system volume in response to zone volume modulation.

## 14-2. Air handling system major components

Air handling systems are comprised of the following major components.

*a. Air handling units.* Air handling units may consist of a supply fan and coil section with a chilled water or direct expansion coil, preheat or reheat coil, heating coil section, filter section, mixing box, or combination mixing box filter section. In some larger units, a return fan may be added to the unit. Air handling units are configured to be either blow-through or draw-through units. Blow-through unit is when one of the coil sections is located downstream of the supply fan. Draw-through unit is when one of the coil sections is located upstream of the supply fan. Draw-through units can be further configured to be either horizontal units or vertical units.

*b. Computer room air conditioners.* Computer room air conditioners are typically factory-assembled units. Indoor units typically consist of fan(s); chilled water or direct expansion coil; steam, electric, or hot water reheat coil; steam or electric humidifiers; and filter section. Hermetic compressor(s) are added to the units when direct expansion coil is used. The outdoor units typically are air-cooled condensing units. Units typically consist of copper tube and aluminum fin coil, direct-drive propeller type fan, and integral electric control panel. On split systems, the condensing unit is the same as described above, except the hermetic compressor is located at the unit instead of being located in the indoor unit.

*c. Chilled water coils.* Fin coils generally consist of rows of round tubes or pipes that may be staggered or placed in-line with respect to the airflow. Flattened tubes or those with other non-round internal passageways are sometimes used. The inside surface of the tubes is usually smooth and plain, but some designs have various forms of internal fins or turbulence devices (turbulators) to improve performance. The individual tubes in a coil are usually interconnected by return bends (U-bends) to form the serpentine arrangement of multipass tube circuits. Chilled water coils usually have aluminum fins and copper tubes, although copper fins on copper tubes are also used.

*d. Hot water coils.* Hot water coils are basically the same as described for chilled water coils. However, the most common circuiting arrangement is often called single-row serpentine or standard circuiting. With this arrangement, all tubes in each coil row are supplied with an equal amount of water through a manifold, commonly called the coil header.

*e. Direct expansion coils.* Coils for refrigerants present more complex cooling fluid distribution problems than water coils. The fin coil that is used for evaporators in most air handling units is typically constructed from copper tubes with aluminum fins. Fin spacings are generally from 6 to 14 fins per inch (2 to 4 mm). Most manufacturers offer a wide choice of fin space and a number of tube rows, usually two to eight in a single casing. The whole tube and fin assembly is enclosed in a galvanized steel casing.

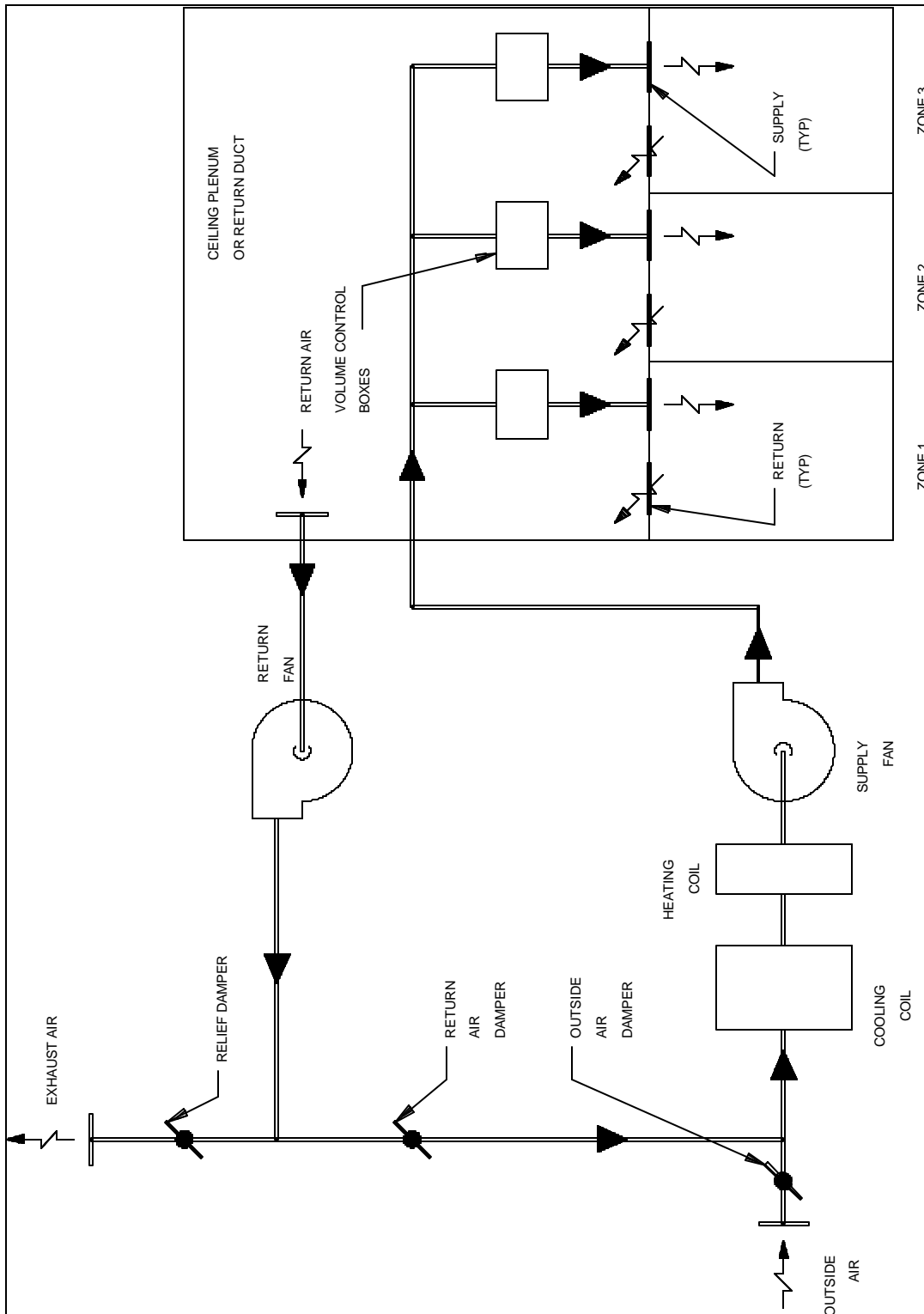

Figure 14-5. Variable air volume air handling system

*f. Steam coils.* Coils generally consist of a steam header and a condensate header joined by finned tubes. The headers may be both at a side of the unit, with U-bends between them, or sometimes an internal steam tube is used to carry the steam to the remote end of an outer finned tube. Vertical headers may be used with horizontal finned tubes, or sometimes horizontal headers at the bottom of the unit supply vertical finned tubes. Copper and aluminum are the materials most commonly used in the fabrication of low-pressure steam coils. Low-pressure steam coils are usually designed to operate up to 150 to 200 psig (1.0 to 1.4 MPa). For pressures higher than 200 psig, tube materials, such as red brass, Admiralty, or Cupro-Nickel, are used. Tubing made of steel or various copper alloys, such as Cupro-Nickel, are used in applications where corrosive materials or chemicals might attack the coils from either inside or outside.

*g. Dehumidifiers.* A dehumidification system is one that takes the water vapor from the air. It may do this by cooling the air below its dew point or by chemical means. The more generally used types will be discussed herein. The three most common types of dehumidification equipment are those which use refrigerant liquid type absorbents and solid-state absorbents. The term "absorb" means to drink in or soak up, like a sponge, by chemical or molecular action. The word "adsorb" means to collect in condensed form on a surface and may be done with a gas, liquid, or dissolved substance.

(1) The refrigeration type of dehumidifier is the most commonly used system. Most cooling systems depend on the dehumidification process to take the moisture out of the air, to achieve the desired comfort level in the room. The refrigerated system has its limitations. The coil temperature can only be cooled to the point where the moisture on the coil does not freeze. If the refrigerated system cannot remove enough moisture from the air, other dehumidifiers, such as solid-state absorbents, are typically used.

(2) Solid adsorbents are those which have the ability to make moisture cling to their surface. The products that are used the most are silica gel, activated alumina, and molecular sieve. These desiccant materials will take the water vapor from air or gas with physical or chemical change. The water vapor that they pick up can be released by passing hot dry air across the surface of the product. These products have submicroscopic cavities that hold the particles of adsorbed water vapor.

(3) The systems that use a liquid absorbent to take the moisture from the air are designed to achieve close moisture control in the room that it is serving. These systems can be used as the only means of temperature/humidity control or can be used with a total air-conditioning system to give complete environmental control.

*h. Humidifiers.* Steam humidifiers are generally used for central air handling systems. But, in order to ensure the advantages of steam humidifiers over other humidifiers, steam humidifiers must provide three performance characteristics: conditioning, control, and distribution. The humidifier must condition the steam to be completely dry and free of significant matter. It must respond immediately to control, provide precise output, and distribute steam as uniformly as possible into the air. Failure of the humidifier to provide these characteristics will result in improper humidification.

*i. Three-way control valves.* Three-way control valves are usually used in air handling systems to control the flow of chilled water or hot water to their respective coils. The valve has one inlet and two outlet connections, and two separate disks and seats. It is used to direct the flow to either of the outlets or to proportion the flow to both outlets. Generally, this valve is used because the pumping system used must maintain a constant flow, i.e., as the valve closes, the flow to the coil decreases, therefore, the water must be diverted to the return side of the system to maintain constant flow.

*j. Control valves.* Control valves are designed to control the flow of steam, water, gas, and other fluids within an air-conditioning system. Valves must be properly sized and selected for the particular application. The valves are made of materials best-suited to the fluid handled, depending upon operating temperature and pressure. Internal parts of valves, such as the seat ring, throttling plug or V-port skirt, disk holder, and stem, are sometimes made of stainless steel or other corrosion-resistant metals, depending upon the fluid handled.

*k. Fans.* Fans are used to move air or other gases or vapors with a fan wheel that makes use of centrifugal or propeller action. Fans can be put into two general classifications: centrifugal fans and axial fans. Centrifugal fans have the flow directed radially outward from the fan wheel. Centrifugal fans are able to move more air at higher pressures and with less noise than axial fans. Axial fan flow is moved parallel to the shaft on which the fan wheel is mounted. All fans have three basic parts: an impeller, motor, and housing. The impeller is the part of the fan that moves the air. In order for an impeller to move air, it must rotate. This is done by power from the motor. Housings are made to fit the individual fan types. Materials used in fan construction are generally steel. They are also built of aluminum and can be made of special materials, such as stainless steel or epoxy-bound fiberglass. Fans can be coated with compounds that are especially suited to the many kinds of corrosive atmospheres in which they must work. In some cases, spark-proof construction is required.

(1) Small fans, especially those whose blades or wheel turn at higher speeds, are equipped with direct-connected motors. For larger size fans, and those that operate at lower speeds, V-belt drives are used. Belt drives have the advantage of giving a lower fan speed than the motor speed and have a built-in shock-absorbing ability.

(2) In some air handling systems, there is a need to change the volume of air that is produced by the fan. Where such a change is made infrequently, the pulley or sheave on the drive motor, or on the fan, may be changed to vary the speed of the fan and thus change the air volume. Dampers may be placed in the duct system to vary the air volume. Variable-speed pulleys and drives, such as electric or fluid drives, may be used to change the fan speed. Two-speed motors and variable fan inlet vanes may also be used to control the airflow rate. Tubeaxial and vaneaxial fans have adjustable blades that vary the airflow rate as required.

(3) A centrifugal fan is built with a wheel that is mounted on a horizontal shaft and turns in a housing. Air enters near the axis of the wheel and is discharged through the housing outlet. Air may enter the fan wheel at one or at both ends of the wheel's axis. The fans that are in use for air-conditioning, heating, and ventilating systems normally do not exceed 10 inches of water (2,488 Pa) static pressure. The main feature that distinguishes one type of centrifugal fan from another is the curvature and the inclination (slope) of the fan wheel blades. The slope largely determines the operating characteristics of the fan. The three principal types of blades are the forward-curved blade, the radial blade, and the backward inclined blade.

(a) The forward-curved blade fans are used primarily for the low-pressure heating, ventilating, and air-conditioning application. Domestic furnaces, low-pressure central station air handling units, and packaged air-conditioning units, such as window and rooftop air-conditioning units, use this type of fan.

(b) In the radial blade fan wheel, the tip of the blade projects straight out from the fan shaft. The radial blade fan can work at a higher pressure than either the forward-curved or the backward-inclined blade fans. However, to move the same amount of air as the other two types, the radial fan wheel requires more horsepower. Due to its low efficiency, the radial blade fan generally is not found in heating, ventilating, and air-conditioning (HVAC) applications. It is used more for material

handling applications, since the wheels are of simple construction and they can be fixed in the field.

(c) In the backward-inclined blade fan wheel, the tip of the blade is inclined backwards away from the direction of the rotation of the fan wheel. This lets the backward- inclined fan move air at higher pressures than the forward-curved fan. It is more efficient (uses less horsepower) for many air volume and pressure ranges than the forward-curved blade fan. The backward-inclined blade wheel is also built with blades that are made in an airfoil shape. This wheel is the most efficient of all types and is the quietest at high static pressure. The backward-inclined fans are generally used in medium to large air handling systems. They are normally used for medium- and high-pressure systems, although they are, at times, used in low-pressure systems.

(4) An axial fan may consist of a fan wheel mounted on a motor shaft or it may have one, or in some cases two, fan wheel(s) mounted on a shaft and confined inside a housing or tube. Axial fans use either a direct drive or a belt drive. The three main types of axial fans are propeller fans, tubeaxial fans, and vaneaxial fans. Axial fans do not develop their static pressure by centrifugal force. The static pressure is gained from the change in velocity of the air when it passes through the fan wheel.

(a) A propeller fan consists of a multiblade impeller within an inlet ring or plate. Propeller fans are low-pressure, high-capacity units built either with the blades mounted on the shaft of an electric motor or a shaft for V-belt drive.

(b) A tubeaxial fan consists of an axial flow wheel within a cylinder or tube. Tubeaxial fans may be used on low- and medium-pressure systems.

(c) Vaneaxial fans are tubeaxial fans with guide vanes that straighten out the axial spiral airflow. Vaneaxial fans can be used in low-, medium-, and high-pressure systems.

*l. Variable air volume terminal units.* A variable air volume system controls the temperature in a space by varying the volume of supply air rather than varying the supply air temperature. Variable air volume terminal units or boxes are used to vary this airflow in each zone or space. There are generally five different types of units that are used: pressure-independent volume units; pressure-dependent, airflow-limiting, maximum volume units; pressure-dependent units; bypass (dumping) units; and supply outlet throttling units. One other type of unit that is used is the fan-powered variable air volume terminal unit.

(1) Pressure-independent volume units regulate the flow rate in response to its respective thermostat's call for heating or cooling. The thermostat controls airflow to the space by varying the position of a simple damper or volume regulating device located in the unit. The required flow rate is maintained, regardless of the fluctuation of the system pressure being supplied by the air handling unit supply fan. These units can be field- or factory-adjusted for maximum and minimum airflow settings.

(2) A pressure-dependent, airflow-limiting, maximum volume unit regulates maximum volume, but the flow rate below maximum varies depending upon inlet pressure at the unit. Generally, airflow will oscillate when system pressure varies. These units are less expensive than pressure-independent units. These units can be used where pressure independence is required only at maximum airflow, where system pressure variations are relatively small, and where some degree of fluctuation or "hunting" is tolerable.

(3) Pressure-dependent units do not regulate the flow rate, but position the volume regulating device in response to the thermostat. These units are the least expensive and should only be used where

there is no need for maximum or minimum airflow control and the air handling unit system pressure is stable.

(4) Generally, in small air handling systems, the cost of a variable air volume system is too high. However, by using bypass (dumping) units in certain zones or spaces, the constant volume system can have variable airflow control. The thermostat controls airflow to the space by varying the position of the volume regulating device. If less air is required to the space, the regulating device closes down and bypasses or diverts some of the air to the return ceiling plenum or return air duct.

(5) Supply outlet throttling units are usually linear diffusers. The area of the throat or the discharge opening varies in approximate proportion to the air volume to maintain throw patterns. The thermostats are usually located at the outlet of the diffuser for easy temperature adjustment. Since these units are pressure-dependent, constant pressure regulators are usually required in the duct system. Noise is a concern when using these units in occupied spaces.

(6) Fan-powered variable air volume units are available in two types: parallel and series flow units. The units have the same components as pressure-dependent or pressure-independent volume units, and in addition, a fan and usually an electric or hot water heating coil. Fan-powered variable air volume units, both series and parallel, are often used for building perimeter heating, because they move more air through a room at low cooling loads and during the heating cycles compared to variable air volume reheat or perimeter radiation systems.

*m. Dampers.* Dampers are devices used to control or restrict the airflow. They fall primarily into three types: volume, backdraft, and fire dampers.

(1) Volume dampers are devices used to vary the volume of air that passes through an air outlet, inlet, duct, fan, air handling unit, cooling tower, or condenser unit. They may vary the volume from 0 to 100 percent of capacity. Some volume dampers can be opened and closed by hand, while others are opened and closed by a pneumatic or an electric operator. The largest use of manual controlled volume dampers in cooling systems is for air balancing.

(2) Backdraft dampers are devices used to limit the airflow within a duct to one direction and to stop airflow through a duct or opening when the fan is shut off. Backdraft dampers are opened automatically by the force of the airflow on the damper blades. They are closed automatically by a spring or weight counterbalance and by gravity. The counterbalances can be adjusted to allow the damper to pass the needed airflow. Backdraft dampers, because they are free to open and close easily, may rattle and make noise. To eliminate this, felt or vinyl strips can be placed on the damper edges, which will also help minimize the air leakage.

(3) Fire dampers are devices used to close off individual sections of a building during a fire. Fire dampers are normally installed where a duct passes through a wall, partition, floor, or ceiling which is specifically designed to provide fire resistance. If ducts pass through barriers having a fire rating of up to and not more than one hour of fire resistance and can be assumed to present no further fire hazard, there is no need for fire dampers. If the wall, partition, ceiling, or floor is required to have a fire resistance rating for more than one hour, a fire damper is then required to properly protect the opening where the ductwork penetrates the wall. Fire damper blades are held open by a fusible link (replaceable) during normal operation of the building. If a fire occurs, the fusible link melts and the damper blades close automatically. For a cooling system to operate properly, all fire dampers must be open all the way. Broken or damaged fusible links should always be changed, and fire dampers should never be wired open. Break-away type connections should be used to connect the ductwork to the fire dampers; solid

connections should never be used.

(4) Smoke dampers are used for either smoke containment or for smoke control. The damper is basically the same as a volume damper, except the damper is classified and listed in accordance with Underwriters Laboratories, Inc. (UL) 555S, UL Standard for Safety Smoke Dampers Fourth Edition (1999). The damper is a two-position damper, i.e., the damper is either open or closed depending upon the control requirements. The dampers are opened and closed by a pneumatic or electric operator. The damper usually has low leakage characteristics.

*n. Unit heaters.* A unit heater is an assembly of a fan and motor, a heating element, and an enclosure whose function is to heat a space. Generally, unit heaters use five different types of heating media: steam, hot water, gas indirect-fired, oil indirect-fired, and electric. Propeller fan units are the most popular units used; however, sometimes centrifugal fan units are used. Unit heaters are used for spot or intermittent heating, such as large outside doors. Unit heaters are used to heat garages, factories, warehouses, stores, etc.

*o. Ductwork.* Ductwork is the system of ducts and ductwork accessories that are used to connect air handling units and fans with the rooms, spaces, or exhaust hoods with which they are associated. The material used for a duct system must be based on the availability of the material, expertise of the duct installer, the type of duct already installed, the location of the installed duct, and the environment it is planned to be used in. For example, a fume hood that handles corrosive fumes should be connected with a non-metallic polyvinyl chloride (PVC) or stainless steel duct. Metallic ducts are usually built from sheets of aluminum or galvanized steel. The ducts may either be built with round or rectangular cross sections. Non-metallic ducts are usually built from fiberglass duct board, except for ducts handling corrosive fumes that are constructed from a PVC material. Fiberglass duct board sheets are generally in locations where the duct will not be damaged by objects or personnel. All joints should be sealed with a special pressure-sensitive tape made for this purpose; standard duct tape should not be used. Round PVC duct systems are built from standard PVC duct and standard fittings. Fittings and ducts are connected with glue. Rectangular PVC ducts are of a special construction and should be made by people who are skilled in this work. Flexible ducts can be bought and used directly without further fabrication. They are available either insulated or noninsulated.

*p. CBR filters.* CBR (chemical-biological-radiological) filters remove chemical and biological agents and radioactive particles from the intake air. Many blast-protected air intake systems allow intake air to bypass the CBR filter elements when the blast protection system is not in the blast mode of operation. While this prevents the performance of the CBR filters from being impaired by a buildup of dirt, the activated carbon filter element deteriorates from exposure to air over time and requires replacement on a regular basis, even if the filter bank has not been in service.

*q. Air filters.* All of the air that is drawn into an air handling system is "contaminated" to some degree. Such contamination may be as solid particles, liquids, fumes, smoke, or bacteria. The process used to remove these contaminants from the air mechanically, electrically, or by absorbing them, is called air filtration.

(1) Viscous impingement filters are of the panel or roll type with a viscous (tacky) coating on the media to hold the particles to the media. The coating is called an adhesive. Viscous impingement filters are made to trap large dust particles from the airstream. Most air-conditioning systems have this type of filter. There are four types of these filters: throwaway, cleanable, automatic renewable media, and automatic self-cleaning media.

(2) Dry media filters, as their name suggests, do not have the tacky coating that is on viscous impingement filters. The dry media filters take out particles from the air by interception and straining. Interception means to filter out particles using the natural forces of attraction between molecules. Straining means to take out particles that are too large to pass through the openings between the fibers.

(3) A filter made of activated carbon will get rid of solid particles, as well as odor-causing gases and bacteria from the airstream. It is possible to clean and reuse the carbon filters. However, this is best done by the manufacturers, who will take out the carbon and process it to be used again.

(4) The inability of standard dry or viscous type filters to take out fine dust particles from airstreams has led to the development of the electrical precipitator. The precipitation method consists of giving an electrical charge to each dust particle in the airstream by passing the air between electrodes and then collecting the dust on parallel plates as the air flows between the plates.

*r. Condensers and condensing units.* Condensers can be put in the following groups: water-cooled, air-cooled, and evaporative. The term "evaporative," when used in reference to the condensing process, refers to the cooling effect brought on by the natural evaporation of water exposed to air currents. The heat rejected by a condenser comes from the heat absorbed by the evaporator and the heat of compression that is added by the compressor. Since the compressor and condenser work as one to compress and condense refrigerant vapor, these two parts, when combined into one package, are called a condensing unit.

(1) Shell-and-tube condensers are used for most of the water-cooled refrigeration systems. The shell-and-tube type of water-cooled condenser is like the direct expansion water chiller. But most shell type water-cooled condensers have the cooling water flowing inside the tubes, and the refrigerant that it condenses is inside the shell, but outside the tubes.

(2) Air-cooled condensers are most popular in areas where water is in short supply, where there is a costly water supply, or where the use of water for air conditioning is restricted at times. They also find wide use in those jobs where low maintenance is a prime need. In addition, air-cooled condensers are used in a lot of installations, because they keep down the cost and do away with the installation of water pipe. They also do not require drainage to keep them from freezing in areas where the climate changes a lot and the cooling system must be turned on and off several times in a year. Propeller fan air-cooled condensers use a fin-and-tube coil like the coil described in the Direct-Expansion Coils section. The refrigerant vapor is condensed inside its tubes by giving up heat to air which flows across the coils. These condensers are, in most cases, placed outdoors, or at least the air is taken to the outdoors.

*s. Diffusers, registers, and grilles.* These are devices used in air handling systems for the supply, return, and exhaust air at intakes and outlets.

*t. Pumps.* The type of pump used to distribute chilled or hot water through the coils in air handling units varies with the system design. There are two basic types of pumps: positive displacement and centrifugal.

*u. Airflow control devices.* Devices that sense the condition of air in a space or in an airflow system act upon other devices to make the air behave in the manner desired.

(1) A thermostat or other temperature control device may move a damper that directs the path of an airstream. It may also change the temperature of an airstream by directing its flow through a coil, or it



can control the volume of air flowing in a duct system. Through the action of a valve, it also may change the temperature of an airstream.

(2) Pressure controls operate to control the pressure of air in a room, or the duct system through the action of dampers. Figure 14-6 shows how a static pressure controller, along with thermostats and dampers, can be used to control static pressure in a variable volume system. The damper being controlled is in the inlet duct to the supply fan, but it could equally well be an inlet vane damper or an outlet damper. The pressure controller could also operate a blower drive speed control. In this control, the pitch of motor and fan pulleys is varied by a device in response to a signal from the pneumatic static pressure controller.

(3) Control of fan speed to control pressure and airflow volume results in less noise than when inlet vanes or outlet dampers are used. In certain installations, the use of speed control also cuts down the horsepower that is needed by the fan or blower drive motor.

(4) Airflow switches are mounted on the side of a duct with the blade inserted into the duct. The blade of the switch will move according to airflow in the duct, and it will make electrical contacts when air flows and break the contacts when airflow stops. The sensitivity of the switch to the airflow may be adjusted. Another control for the same purpose as the ones described above is the differential pressure switch that senses velocity pressure in the duct. This controller also has an adjustable pressure range.

v. *Valves and piping.* Valves installed in the air handling system are to control water flow and to isolate equipment for ease of operation and maintenance.

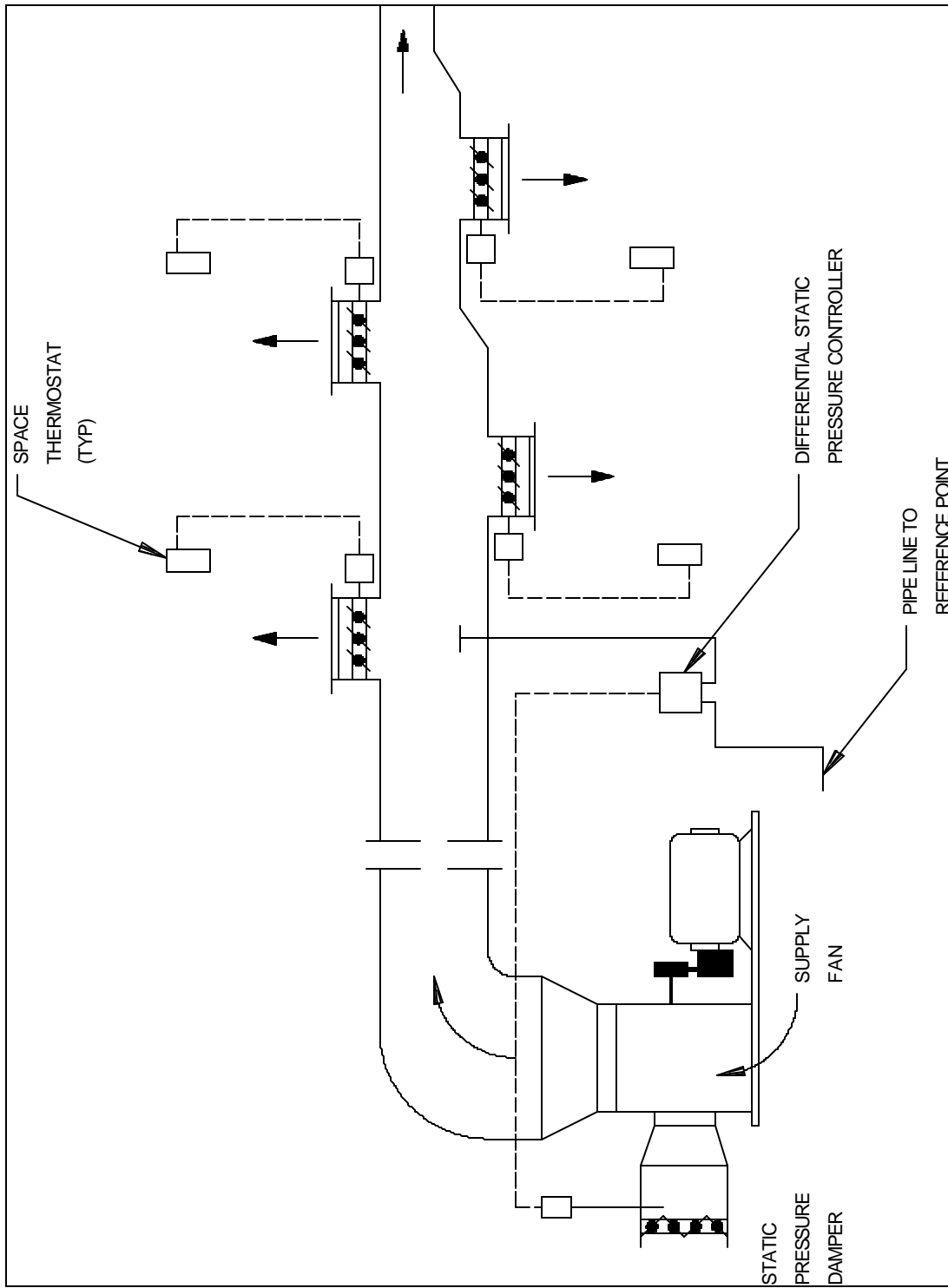

Figure 14-6. Typical air handling systems controls

## CHAPTER 15

### INDUSTRIAL WATER SUPPLY SYSTEMS

---

#### 15-1. Industrial water supply system design features

This chapter presents an overview of industrial cooling systems and their various components. The industrial cooling system is the means by which heat generated by facility equipment (diesel engines, thermal storage refrigeration, and chillers, typically) is removed from the facility. Under normal operating conditions, this heat will be rejected to the outside by cooling towers and the condenser water piping system. When the cooling towers are not operating, this condenser water is circulated through the industrial cooling system and reservoir(s). Each industrial cooling water system is designed to transfer heat by the most efficient and reliable method. While there is no right way to design an industrial cooling system, all industrial cooling water systems have common characteristics and use common types of components.

*a. Terminology.* For the purposes of this manual, the term "industrial cooling system" refers to any heat removal system that uses a body of water as a heat sink. A condenser water system refers to a system that removes heat with cooling towers. There may be some confusion in the use of this terminology because some facilities refer to an industrial cooling water system as that which removes heat with both cooling towers and a heat sink (industrial reservoir). A condenser water system and an industrial cooling system both serve the same function, heat removal. In addition, these two systems share much of the same piping, valves, and additional system components.

*b. System functions.* Industrial cooling is used in the event of failure of the normal condenser water system, or if cooling towers are to handle the facility head load. The system may also be used during a variety of operating scenarios including testing, blowdown of the condenser water system, maintenance, crew training, load shedding, or blast conditioning. The primary function of the industrial cooling system is to serve as a backup for the condenser water system. The condenser water gains heat as it is circulated through the facility equipment (chiller condensers, diesel engine jacket water heat exchangers, diesel engine lubricating oil heat exchangers, thermal storage refrigeration units, etc.). This warm condenser water then travels through the cooling towers, giving up the heat it gained, and is pumped through the circuit again by the condenser water pumps.

*c. Reservoir water supply.* The reservoir water supply system has the function of providing industrial water to each facility for storage in the industrial reservoirs. Water is supplied to the reservoirs by one of two ways. One method is by water wells located on or outside of the facility. The second method is by pumping stations that deliver the water into the facility from an external water treatment or monitoring facility. With either method, the pumps can be controlled locally or from a remote control station, and they can be manually started or operated automatically by a level controller located at the reservoir. Another source of water to the industrial reservoir may be underground spring water.

*d. Reservoir cooling system.* During industrial reservoir cooling, the cooling towers and condenser water pumps are turned off, reservoir pumps are activated, and control valves are positioned to divert water around the towers and pumps. The warm condenser water (now referred to as industrial water) is delivered to the industrial reservoir. As the returned industrial water makes its way through the reservoir to the reservoir pump suction, the reservoir acts as a heat sink by dissipating the heat gained by the industrial cooling water. The heat capacity of the industrial reservoir is dependent on facility cooling and

electrical loads, and volume of water in the reservoir. When industrial reservoir cooling has been operating for an extended period of time, the industrial reservoir will lose its ability to dissipate heat from the returned industrial water. This occurs when the reservoir reaches a certain temperature. At that temperature, reservoir dump is begun. Reservoir dump is simply the removal of the hot reservoir water from the facility.

*e. Makeup water system.* The industrial cooling system requires makeup water at all expansion tanks. The makeup water system replaces water lost in the condenser water or industrial water systems. As pressure in the expansion tank decreases, the makeup water valve will open allowing makeup water to enter the system until the pressure increases to a point above the setting of the makeup water valve. Makeup water does not apply to the industrial reservoirs, since water is continuously supplied to the reservoir based on the water level in the reservoir. As the water level in the reservoir falls, the water level controller will automatically activate the supply pumps to replenish any water lost from the reservoir.

*f. Water treatment.* Water treatment consists of maintaining approximately 1 ppm (part per million) residual chlorine in the industrial reservoir of the industrial cooling system. A hypochlorinator unit is used to inject chlorine into the reservoir piping system. The industrial reservoir water should be checked (tested) daily to determine whether chlorine is needed. If the reservoir residual chlorine is in excess, reservoir water should be drained while adding fresh water from the supply system until the residual chlorine is approximately 1 ppm. This should only be done during normal operating conditions. Additional water treatment may be required at the cooling towers and for the condenser water system.

## **15-2. Industrial water supply system major components**

Industrial water supply systems are generally comprised of the following major components.

*a. Reservoirs.* Water storage reservoirs are used for both domestic water and industrial cooling. The reservoirs are unlined rock chambers that extend, mostly horizontal and slightly down, from a common audit area. The reservoirs may include a steel bulkhead or concrete dam in front to retain the water within the reservoir. In addition, the reservoir may include a pump platform, located above the water level, from which the reservoir water is drawn by the distribution pumps.

*b. Tanks.* Surge tanks are used in the reservoir water supply system to absorb water surging or water hammer shock in the industrial water supply line between the reservoir and the supply pumps. The tank is a closed tank pressurized with compressed air which absorbs the water surges caused by starting and stopping of pumps. A liquid level control maintains a constant air pressure in the tank by modulating an air supply valve. Expansion tanks are used in industrial cooling (condenser) water systems to allow for thermal expansion and to provide a location for makeup water to be admitted to the system.

*c. Wells.* Wells extract water from permeable water bearing layers called aquifers. The wells used for industrial water supply systems typically have an 8- or 6-inch casing which fills with water. A pump forces the water up to the surface.

*d. Pumps.* For an expanded discussion of pumps which can be used in industrial water systems, see chapter 11.

*e. Control valves.* Control valves are used in condenser/industrial water systems to control the flow of water through the piping system. The control system positions the valve through a valve operator or actuator that is directly attached to the valve stem. Control valves must be carefully sized and selected for the particular design conditions. Control valves used in condenser/industrial water are typically equipped with a throttling plug or V-port that is specially designed to provide the desired flow characteristics.

*f. Valves.* For a discussion of the types of valves which may be used in industrial water systems, see chapter 11.

*g. Strainers.* Strainers are defined as a closed vessel with cleanable screen element designed to remove and retain foreign particles down to 0.001 inch diameter from various flow fluids. A strainer differs from a filter in that strainers trap particles that are typically visible to the naked eye. Strainers are typically installed in condenser water systems on the inlet (suction) side of the distribution pumps.

*h. Piping.* Pipe used in industrial/condenser water systems for sizes 2 inch and smaller is typically standard weight, continuous weld steel pipe with threaded joints and cast iron fittings. For industrial/condenser water piping larger than 2 inches, steel pipe conforming to American Society for Testing and Materials (ASTM) A 53, Standard Specification for Pipe, Steel, Black and Hot-Dipped, Zinc-Coated, Welded and Seamless (1999), is used. Joint types for this size of pipe are either welded, flanged, or grooved. Fittings for A 53 type pipe are wrought steel, cast iron, and malleable or ductile iron.

### 15-3. Testing

The industrial reservoir(s) plays a critical role in the success of a given facility's mission. Because the industrial water system is required to be operational before the systems it supports can operate, it is probably the most important system in the facility. Due to this fact, the reservoir should be placed through a series of tests periodically to provide reassurance that the industrial reservoir maintains a high level of reliability and will perform adequately when needed. The following items should be considered when developing a testing procedure for the industrial reservoir.

*a. Record information.* Prior to beginning any test on the industrial reservoir, always record the following information: the reservoir water temperature, the water level or the amount of water in the reservoir, individual condenser water flow rates through all equipment, entering and leaving temperatures of condenser water through all equipment, total condenser water flow to the cooling towers, and condenser water supply temperature to and return temperature from the cooling towers. Always record the date and exact time the test was begun. In addition, record the time any significant changes occur in flow rates and temperatures in the system, along with this new data. Always record the ending time of the test.

*b. Manual switchover.* The ability of the condenser water system to switch to industrial reservoir cooling should be tested manually by opening/closing valves locally, and starting and stopping the appropriate condenser water and industrial reservoir pumps, also from local control stations. Personnel should be assigned specific tasks and timed as to how long is required for manually switching the entire condenser water system over to industrial reservoir cooling.

*c. Remote switchover.* The ability of the condenser water system to switch to industrial reservoir cooling by initiating reservoir cooling from a central control room should be tested.

*d. Automatic switchover.* The ability of the condenser water system to switch to industrial reservoir cooling automatically by simulating a blast as detected from the blast sensors should be tested.

*e. Temperature.* Once industrial reservoir cooling is initiated, the temperature of the reservoir should be monitored and recorded at regular time intervals until the completion of the test. In addition, the flow rate into and out of the reservoir should be continuously monitored and recorded, again until the test is completed.

*f. Reservoir dump.* If reservoir dump is initiated, the starting time, flow rate, temperature of reservoir water, and stopping time should be recorded.

*g. Fresh water.* If fresh water is added to the reservoir during testing, the following should be recorded: the supply water temperature to the reservoir, the exact starting time that water is supplied, the flow rate of water to the reservoir, the temperature of the reservoir when the water was added, the temperature of the reservoir when the supply to the reservoir stopped, and the exact time when the supply to the reservoir stopped.

## CHAPTER 16

# COMPRESSED AIR SYSTEMS

---

### 16-1. Compressed air system

There is no specific way to compress air, however, each system consists of certain typical components. Figures 16-1 through 16-4 provide a depiction for these components and their arrangements.

*a. Components.* Compressed air systems consist of compressor units with drives, controls, intercoolers, and inlet air filtration; compressed air-conditioning equipment consisting of aftercoolers, receivers, filters, separators, traps and drains, and air dryers; and air distribution systems, including piping, valves, control valves, filters, pressure regulators, drains, lubricators, etc.

*b. Applications.* Compressed air is probably one of the most universal operations within a plant environment. It transcends industries, operations, and applications. Compressed air is used to power tools, move conveyers, transport products, and make process applications possible. Considered a power source, compressed air systems are increasingly more reliable and predictable. It is often considered the fourth utility.

### 16-2. Compressed air system major components

Compressed air systems are comprised of the following major components.

*a. Compressor.* The compressor is the main component of the system. The key issues involved in ensuring the compressor performs as necessary are reliability, cost-effectiveness, ease of operation, and maintainability. Compressor reliability is based on the type of control system, ambient temperature, motor design, and the cooling system.

(1) Modern day use of electronic controls has eliminated many problems associated with mechanical switches and relays. Older pneumatic compressor controls using compressed air taken before the air dryer can prove troublesome because moisture in the air leads to sluggish performance and damage to the compressor. The rubber diaphragms used with these pneumatic control systems are a common weak link in control systems. The control system should be easy to use and provide required data.

(2) The compressor must be capable of operating in ambient temperatures approaching 110-115° F because compressor rooms are 5-10 degrees warmer than the outdoor temperature. Higher temperature ratings mean longer, more reliable periods between maintenance.

(3) As a minimum, motor insulation must be class F. Temperatures inside the sound attenuating enclosures for motor and compressors are warmer than the ambient air. Summertime operation gives internal temperatures from 110 to 115° F. Standard Class B insulation motors are designed for a maximum installed temperature of only 104° F.

(4) During operation, the compressor produces a tremendous amount of heat that must be removed. The compressor oil removes some of heat. Lubricated compressors remove even a higher portion of the heat since the oil is in the compression chamber. The oil is then cooled in a forced draft

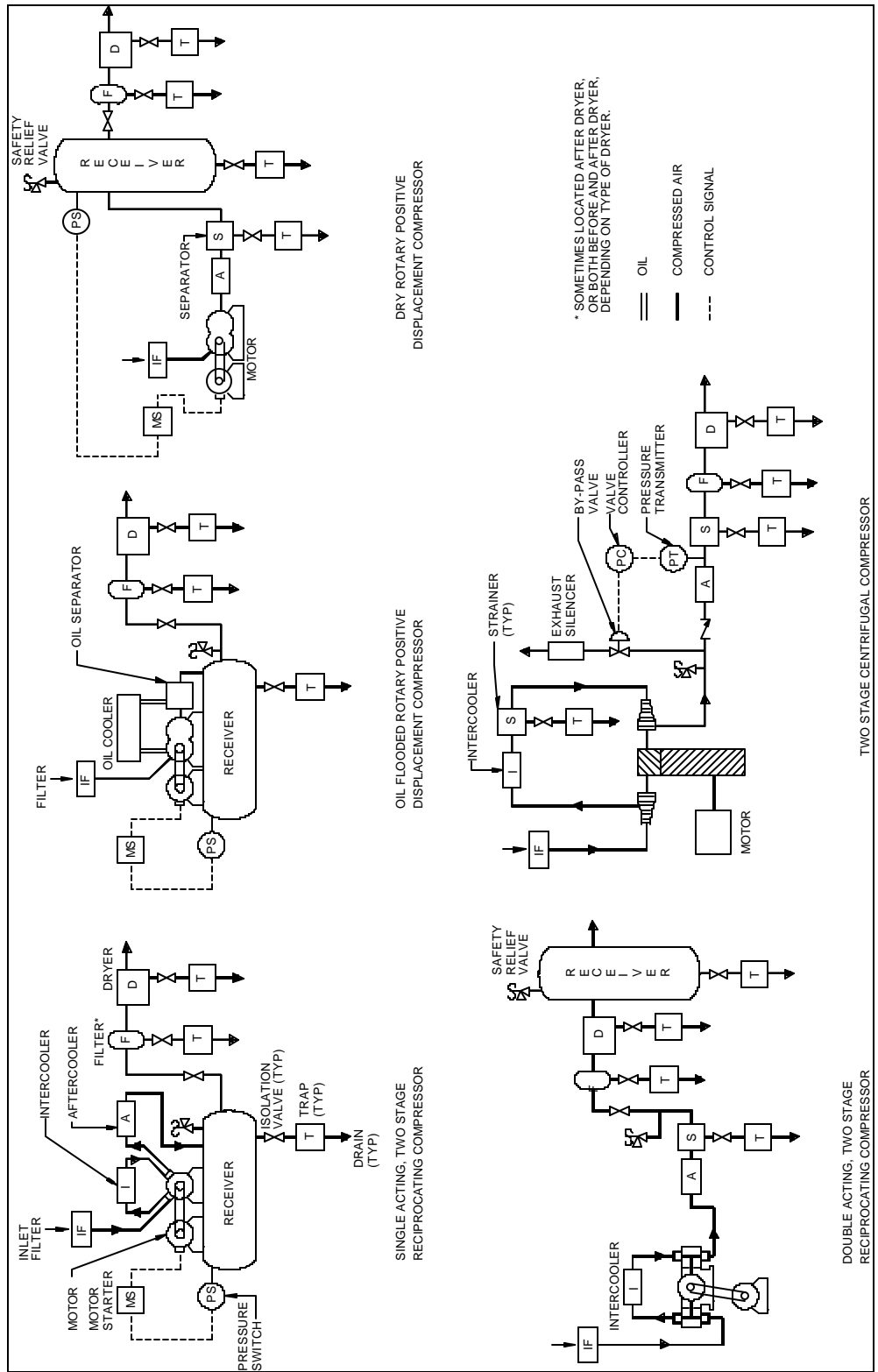

Figure 16-1. Typical air compressor systems



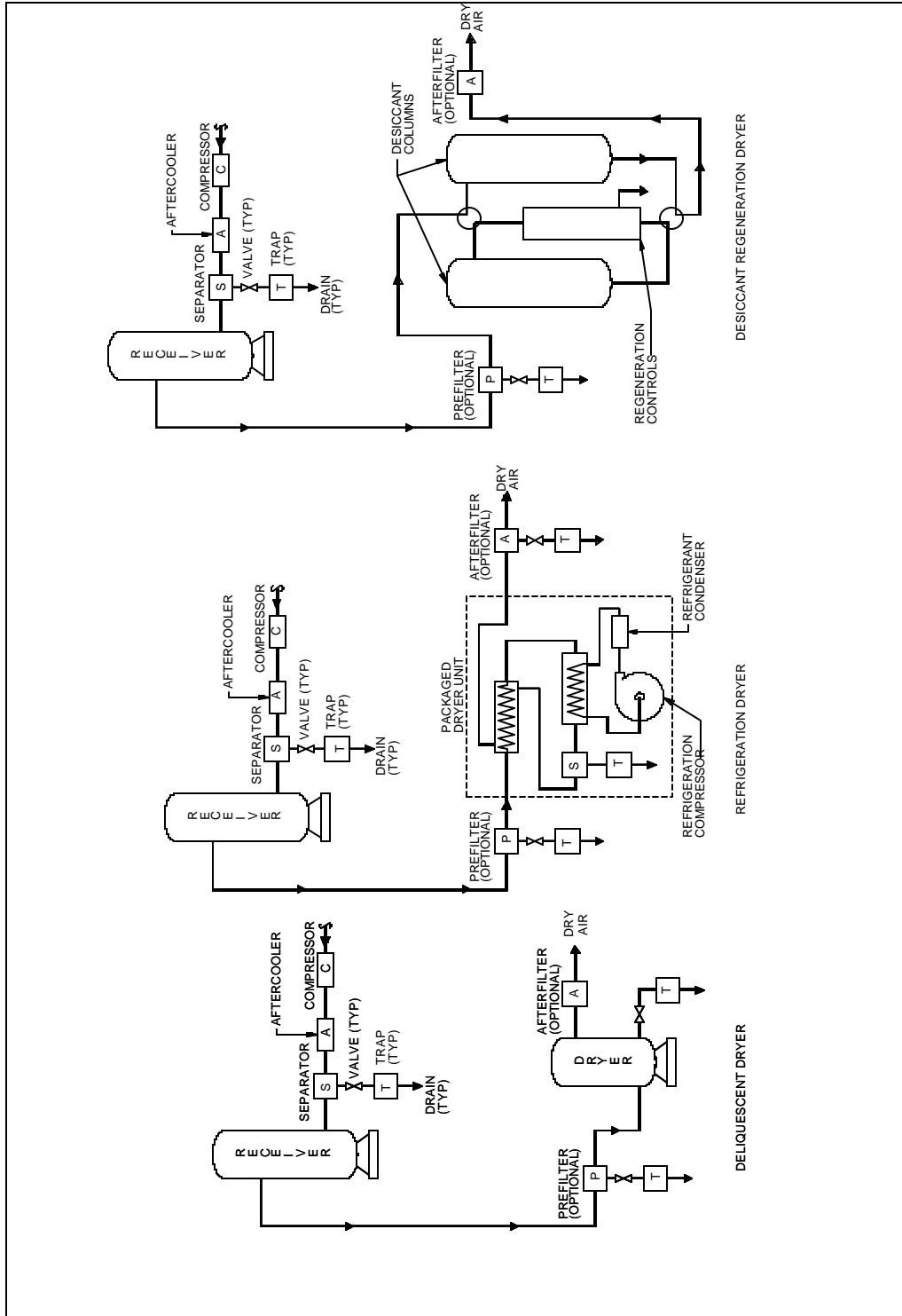

Figure 16-2. Typical air dryers

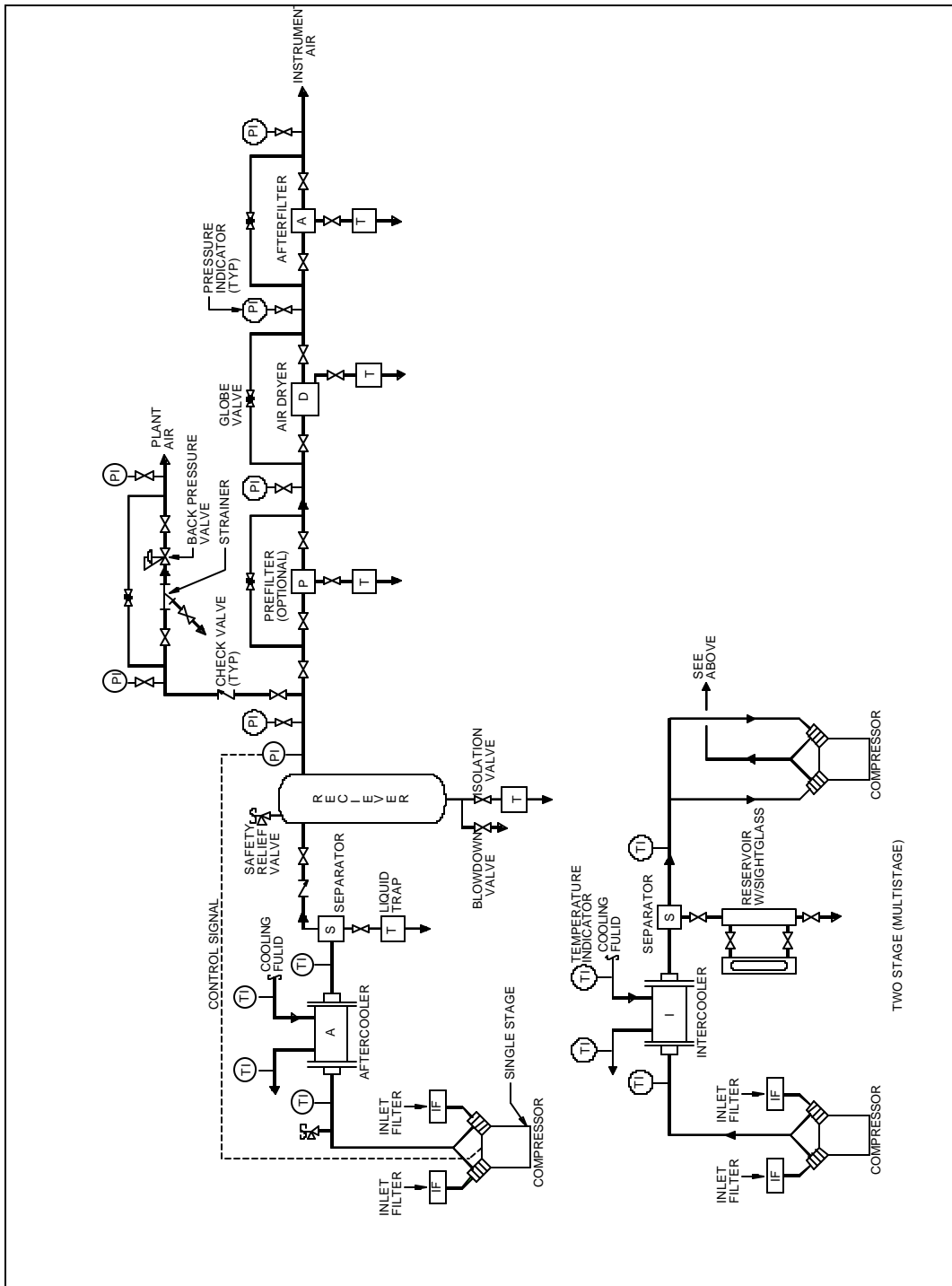

Figure 16-3. Typical air compressor installation

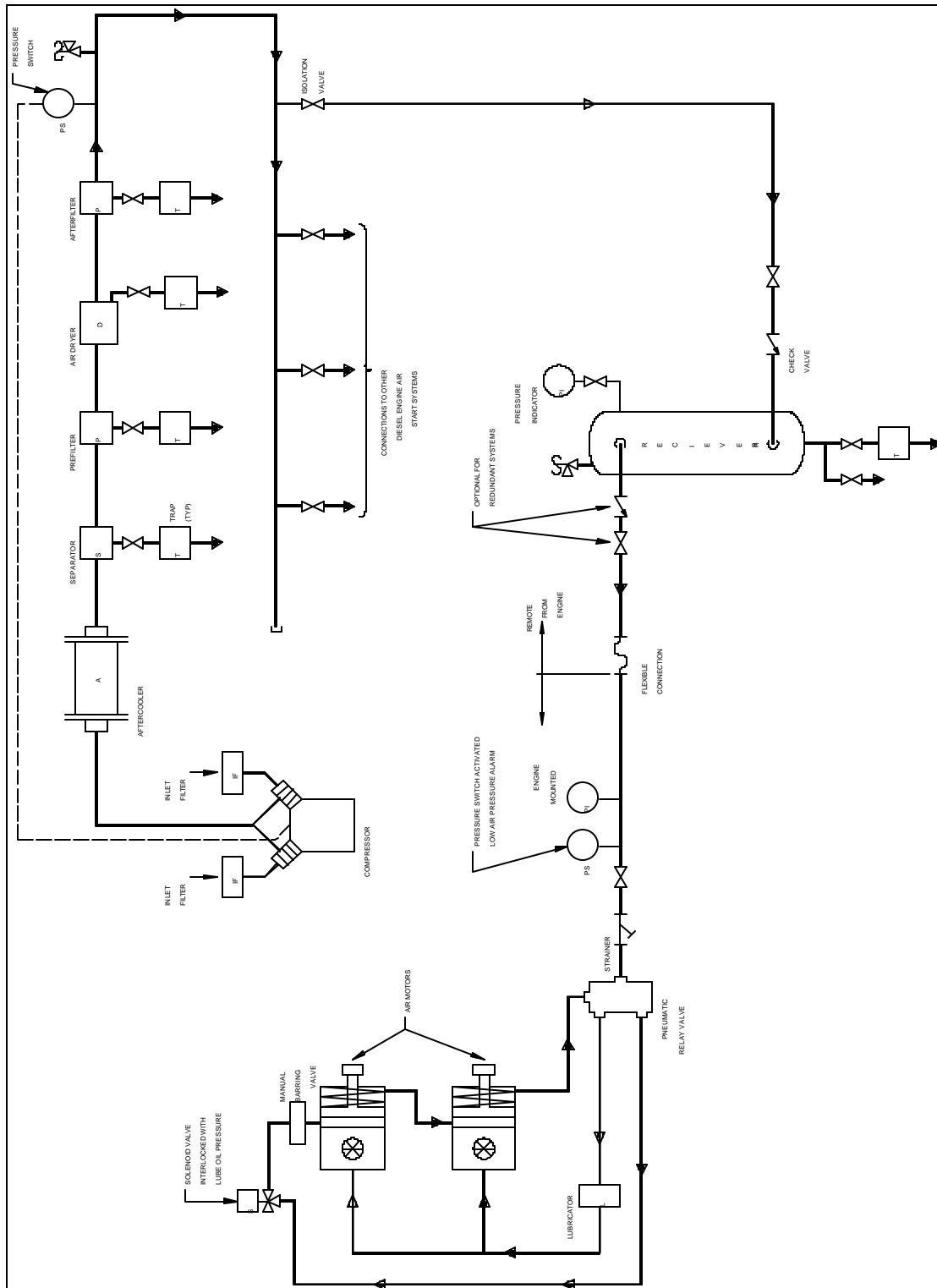

Figure 16-4. Typical engine compressed air starting system

air-cooled heat exchanger. That portion of the heat remaining is removed in intercooler and aftercoolers of sufficient capacity to permit continuous, fully loaded compressor operation in high ambient temperatures. The aftercooler approach temperature, that is, the temperature difference between the compressed air outlet and ambient air temperature, should be in the 15 to 20° F range.

(5) The compressor should be easily accessible for maintenance. If enclosed, the panels should be easily removed. Leave at least three feet of clearance around the compressor. The primary maintenance items on a compressor are the inlet filter, oil drain, oil fill, motor greasing, condensate traps, and control calibration. Each should be easily accessible. Service indicators help guarantee timely maintenance. In lubricated compressors, the oil travels downstream and must be replenished regularly. Synthetic lubricants provide superior lubricating characteristics, longer service life, and lower vaporization rates. Polyglycols extend changeout intervals to 8,000 hours, have the lowest vaporization rate, and are biodegradable. Oil-free compressors require limited amounts of lubricant for bearings and gears.

*b. Air purification.* The air purification system is an integral part of the process because it ensures that the air produced is of a high quality to preclude deterioration of the piping system and associated valving. The primary functions of the air purification system are to deliver the required air quality, maintain air quality during upsets, and minimize operating costs. Generally, air purification falls into one of three categories: filters, dryers, and receivers.

(1) Filters remove condensed liquids, particulates, and oil vapors. Coalescing filters to remove water and oils have efficiencies from 99.98% at 0.01 micron particle size to 99.9999% at 0.1 micron. The filters should have a maximum wetted pressure drop of 3 to 3.5 psi. The maximum pressure drop, normally 10 psi, determines the service life of these filters. Expect to replace the filter elements every six to twelve months. High-performance coalescing filters require changeout every five years. Although these filters have a higher first cost, the lower pressure drop and reduced energy and maintenance costs provide a simple payback of less than one year. Particulate filters installed downstream of a desiccant dryer should have a differential pressure gauge to indicate the condition of filter elements rated for a nominal efficiency of 99.95% at 1 micron particle size and initial pressure drop of 1 psi. Coalescing filters must have high-quality automatic condensate drains. Vapor removal and filters absorb oil vapors with activated charcoal. Location and the oil concentration determine filter element life. Normal pressure drop for a vapor removal filter is 1 psi.

(2) Air dryers are a very important part of the overall system because an aftercooler discharging compressed air at 100°F passes 67 gallons of water per 1,000 standard cubic feet/minute (scfm) per 24 hours. Instrumentation fails when water and lubricant condense as the air is further cooled in the piping system or as the air expands through the orifices. The air exiting the aftercooler is saturated and any further temperature drop results in more condensation. A useful rule of thumb states that "a 20 degree reduction in temperature condenses one half the water vapor in saturated air."

(a) Air dryers reduce the moisture content as measured in terms of a pressure dew point (pDp) that is based on a specific set of inlet conditions to the dryer. Dew point is the temperature at which water vapor condenses -- saturated, 100% relative humidity. Pressure dew point is the dew point of the air at operating pressure. Atmospheric dew point refers to air expanded to atmospheric conditions. To avoid confusion, specify dryer performance in terms of pressure dew point.

(b) The instruments and the lowest expected ambient temperature determine the drying method. The most common dryer is a refrigerated unit that cools the compressed air, condenses water and oil vapors, separates them, and drains them from the system. The "dried" compressed air is then fed to the instrument air system.

(c) Dryer performance is specified as a pressure dew point class that is based on specific inlet and ambient conditions. The lowest pressure dew point class with a refrigerated dryer is Class H. This class delivers a pressure dew point of 33 to 39° F. Refrigerated dryers should not operate below the Class H range because the water vapor will freeze in the dryer. The highest practical pressure dew point for a refrigerated dryer is 60° F because higher pressure dew points give condensation in downstream piping. In the United States, most dryer manufacturers base the pressure dew point performance on standard conditions: inlet air flow, 100° F inlet air temperature, 100 psig operating pressure, 100° F maximum ambient temperature (air-cooled units), 85° F cooling water temperature (water-cooled units), and 5 psi maximum pressure drop.

(d) Adjust air dryer sizing to account for deviation from standard conditions. For example, elevating the inlet air temperature 10 degrees increases the load on the dryer by more than 25 percent and raises the outlet pressure dew point above 50° F. Maintaining the original 33 to 39° F dew point now requires a dryer 35 percent larger.

(e) Non-cycling and cycling are the two types of refrigerated dryers. On a non-cycling dryer, the refrigeration compressor runs continuously regardless of dryer load. A thermostatic expansion valve and hot gas bypass valve regulate the flow of refrigerant into the heat exchanger to maintain dew point and minimize "freeze-up." Since the unit uses full input power at all times, a non-cycling dryer should be selected for systems with a constant air flow. In cycling dryers, the refrigerant cools an intermediate fluid that cools and "dries" the air. During low-load operation, the refrigeration circuit stops its compressor and restarts it when the fluid temperature rises. The cycling type dryer conserves energy and minimizes dryer freeze-up making cycling dryers the choice with fluctuating air flow and inlet temperatures. Over-sized cycling dryers provide additional drying capacity for future air system upgrades.

c. *Air receivers.* The final major components needed are the air receivers. Air receivers provide storage capacity to prevent rapid compressor cycling; reduce wear and tear on compression module, inlet control system, and motor; eliminate pulsing air flow; avoid overloading purification system with surges in air demand; and damp out the dew point and temperature spikes that follow regeneration. A rule of thumb is to provide a minimum of one gallon of receiver capacity for each cubic foot of compressor flow.

d. *Piping.* Consideration must be given to critical pipe lengths of the air discharge pipe, and certain lengths must be avoided to prevent resonance. The critical lengths vary with the type and size of air compressor, and can be determined from air compressor manufacturers. Consideration will also be given to surge volume between reciprocating compressors and aftercoolers to minimize vibration and wear in the tubes and tube supports or baffles in the aftercoolers. Pulsation dampers or surge bottles at the compressor discharge will increase the installation cost, however, they may reduce maintenance costs because attenuation of discharge pulsations reduces wear and the potential of tube failures.

e. *Safety valves.* A safety valve must be provided between a positive displacement compressor discharge and any block valve or other flow restricting device, as well as between the compressor and an internally finned tube aftercooler. This is particularly true with lubricated compressors. If deposits should clog the aftercooler, proper protection would be afforded. Safety valves should be connected directly into the piping at the pressure point it is sensing, without unnecessary additional piping or tubing. Safety valve discharge should be directed away from personnel areas and traffic lanes.

f. *Other components.* Other components that are part of the system are various control valves, control switches, pressure switches, drains, electrical controls, and wiring.

### **16-3. Compressed air system interfaces**

The compressed air system interfaces with many other systems within the plant or site. Primary interfaces are with the electrical system and the various process systems that the compressed system serves.

## CHAPTER 17

# PNEUMATIC CONTROLS

---

### 17-1. Pneumatic control design features

Pneumatic controllers for the most part rely on compressed air as described in the previous chapter. Additional air dryers and filters may be added locally in the area of interest in addition to those back at the compressor station.

*a. Components.* The next stage in control is the pressure regulator or regulators. At this point one or more operating pressures are set for the equipment in the area with each operating pressure having its own dedicated line. From this line(s) various pieces of equipment can operate. The simplest would be pressure gauges that measure the process relative to atmosphere or another set pressure. Next would be control switches that would activate either electrical circuits or pneumatic circuits based on pressure set point or set points. For example, the reset state could be set at a different set point from the initiation set point. Then there are thermostats, a control switch that operates based on the process temperature or in another case the outside temperatures to which the process is exposed. See figure 17-1 for an example of this case. At the next level are pressure transmitters and controllers. This class of service acts as a pneumatic amplifier to send pressure changes over greater distances and/or to generate enough energy to operate a valve or piston. There are many variations to these devices to allow for feedback proportional and derivative control. For maintenance review, site process drawings, data sheets, and manufacturers' information should be used.

*b. Applications.* Tools and appliances driven by compressed air are known as pneumatic devices. Examples of these devices are rock drills, jackhammers, spray painters, and air brakes. In some cases, air suction instead of compression is used to operate the tool or appliance, as in the familiar vacuum cleaner. Pneumatic devices are flexible, efficient, and safe. An air device creates no sparks. This is an important consideration for work in dangerous areas. Air compressors used in pneumatic tools and appliances may be either reciprocating--that is, driven by the up-and-down motion of a piston in a cylinder--or rotary, in which the air is compressed by a device similar to a centrifugal or axial pump.

### 17-2. Pneumatic control systems major components

Pneumatic control systems are comprised of the following major components.

*a. Air motors.* Pneumatic devices are operated by two types of air motors: rotary and reciprocating. These air motors are the opposite of reciprocating or rotary air compressors. In a rotary device, also known as an air turbine, compressed air enters the motor housing, pushes on the rotary blades, and rotates a central shaft or spindle. Small devices can be run at speeds up to 30,000 revolutions per minute. Reciprocating pistons are driven as compressed air enters the cylinder, expands, and forces the piston to move. The return stroke is triggered either by compressed air pushing on the other side of the piston or by spring action. Pneumatic tools are commonly supplied with compressed air at or above 100 pounds per square inch (690 kilopascals). Air motors do not become hot when overloaded and can stand repeated stalling and rapid reversals without damage. Pneumatic tools of different sorts are used for a variety of purposes. Portable pneumatic tools are normally powered by rotary air motors and include grinders, buffers, drills, screwdrivers, chipping hammers, and various specialty tools such as paint mixers, concrete

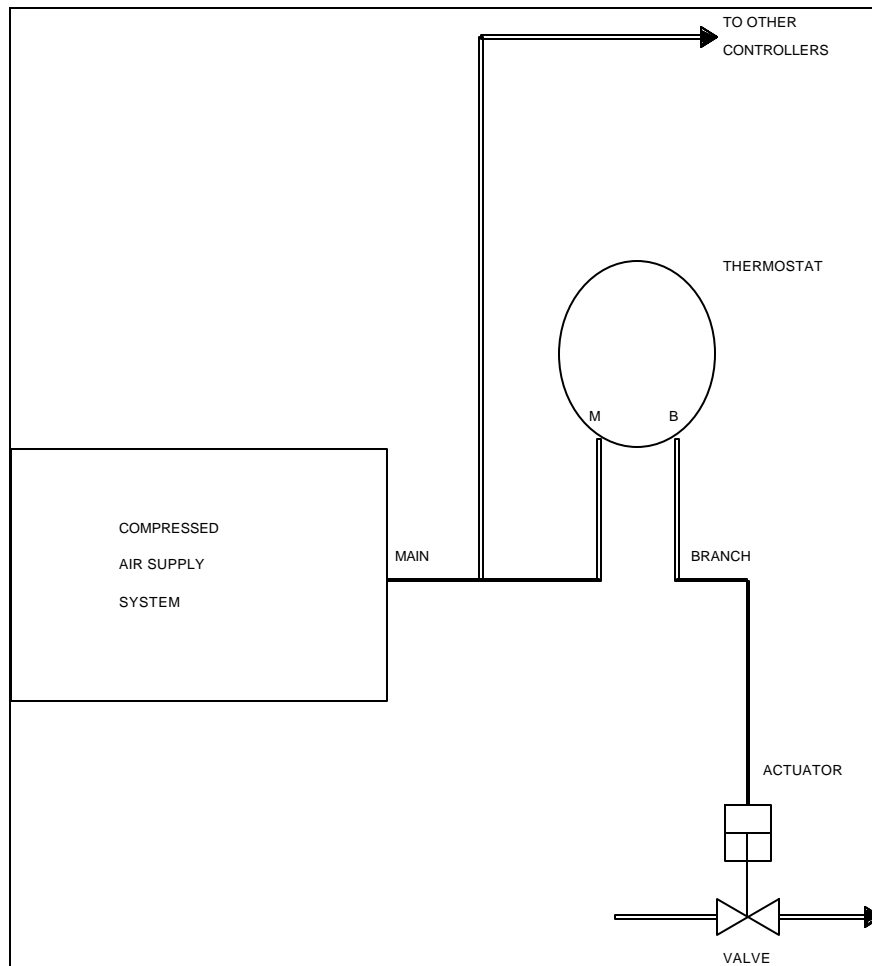

Figure 17-1. Basic compressed air supply to pneumatic control system

vibrators, and spikedrivers. Rock drills are heavy-duty machinery used for mining and rock excavation and are powered by reciprocating piston motors. Here, a high-carbon steel drill is held loosely in a chuck at the end of a cylinder and is struck by rapid blows from the freely moving piston. Major pneumatic devices include jackhammers, pneumatic drills and wrenches, spray guns, pneumatic conveyor systems, and brake systems. They have wide application in home and industrial use. Jackhammers, or paving breakers, are powered by a reciprocating piston that strikes a solid street drill that usually has a wedge-shaped end. Heavy jackhammers are used to break up road surfaces, concrete, and boulders; lighter versions are used on light concrete floors, frozen earth, and ice.

*b. Instrumentation.* Instruments are the means for monitoring or measuring physical variables. The basic element of instrumentation is the transformation of one form of energy into another form. Producing meaningful information from physical variables requires conversion and processing. Electronic instruments require that physical variables be converted to electrical signals through a process of *transduction*, followed by signal *conditioning* and signal *processing* to obtain useful results.

(1) The measured parameter can be one of many physical variables; the type depends on the application. For example, in process control, typical measured parameters can include pressure, temperature, and flow.



(2) Transducers convert one form of energy to another. To be useful for an electronic instrument, a transducer must produce an electrical output such as voltage or current to allow required signal conditioning and signal processing steps to be completed. A variety of transducers are available to meet measurement requirements and can be compared based on their operating principles, measurement range, interface design, and reliability.

*c. Process control.* Process control typically involves some mechanical system that needs to be operated in such a fashion that the output of the system remains within its design operating range. The objective of a process control loop is to maintain the process at the set point under the following dynamic conditions.

- (1) The set point is changed.
- (2) The load on the process is changed.
- (3) The transfer function of the process is changed or a disturbance is introduced.

*d. Closed-loop operation.* The classical control system representation is a feedback-loop system. A feedback (or closed-loop) system contains a process, a sensor, and a controller. A process is a system that produces a motion, a temperature change, a flow, a pressure, or many other actions as a function of the actuator position and external inputs. The output of the process is called the process value. If a positive action in the actuator causes an increase in the process value, then the process is called direct acting. If positive action in the actuator decreases the process value, it is called reverse acting.

(1) A sensor is a pneumatic, fluidic, electronic or other device that produces some kind of signal indicative of the process value.

(2) The set point is the desired value for a process output. The difference between the set point and the process value is called the process error.

(3) A controller sends signals to an actuator to effect changes in a process. The controller compares the set point and the process value to determine the process error. It then uses this error to adjust the output and bring the process back to the set point. The controller *gain* dictates the amount that the controller adjusts its output for a given error.

(4) An actuator is a pneumatic, fluidic, electric, or other device that performs any physical action that will control a process.

### 17-3. System operation

As discussed in the previous sections, the major operation of the pneumatic control system is controlled by the compressed air system. Various variables can affect the proper operation and require strict control and maintenance processes.

*a. Disturbances.* An external disturbance is any effect that is unmeasured or unaccounted for by the controller.

*b. Time constant.* The time constant of a sensor or process is a quantity that describes the dynamic response of the device or system. Often the time constant is related to the mass of an object or other dynamic effect in the process. For example, a temperature sensor may have a protective sheath around it that must first be warmed before the sensor registers a change of temperature. Time constant can range from seconds to hours.

*c. Dead time.* The dead time or lag time of a process is the time between the change of a process and the time this change arrives at the sensor. The delay time is not related to the time constant of the sensor, although the effects of the two are similar. Large dead times must be properly treated by the control system to prevent unstable control.

*d. Hysteresis.* Hysteresis is a characteristic response of positioning actuators that result in different positions depending on whether the control signal is increasing or decreasing.

*e. Dead band.* The dead band of a process is that range of the process value in which no control action is taken. A dead band is usually used in two-position control to prevent “chattering” or in split-range systems to prevent sequential control loops from fighting each other.

*f. Control point.* The control point is the actual, measured value of a process (i.e., the set point + steady-state offset + compensation). A direct-acting process will increase in value as the signal from the controller increases. A reverse-acting process will decrease in value as the signal from the controller increases.

*g. Stability.* The stability of a feedback control loop is an indication of how well the process is controlled or, alternatively, how controllable the process is. The stability is determined by any number of criteria, including overshoot, settling time, correction of deviations due to external disturbances, etc.

## CHAPTER 18

### SANITARY WASTE SYSTEMS

---

#### 18-1. General sanitary waste systems

A sanitary waste system is a system that conveys and handles sewage and excludes storm, surface, and ground water. Sewage is any liquid waste containing animal or vegetable matter in suspension or solution, including liquids containing chemicals in solution. The purpose of the sanitary waste system is to collect the waste generated at the plumbing fixtures, floor drains, and equipment drains, and to convey and dispose of this waste in an environmentally safe manner.

#### 18-2. Sanitary waste system design features

Treatment requirements will be determined on the basis of meeting stream and effluent requirements set by either U.S. or State governments or foreign governmental agencies. Methods of treatment are grouped below.

*a. Preliminary treatment.* Preliminary treatment is defined as any physical or chemical process at the wastewater treatment plant that precedes primary treatment. Its function is mainly to protect subsequent treatment units and to minimize operational problems. Pretreatment at the source to render a wastewater acceptable at the domestic wastewater treatment facility is not included.

*b. Primary treatment.* Primary treatment is defined as physical or, at times, chemical treatment for the removal of settleable and floatable materials.

*c. Secondary treatment.* Secondary wastewater treatment is defined as processes that use biological and, at times, chemical treatment to accomplish substantial removal of dissolved organics and colloidal materials. Land treatment can be classified as secondary treatment only for isolated locations with restricted access and when limited to crops that are not for direct human consumption.

*d. Advanced wastewater treatment.* Advanced wastewater treatment is defined as that required to achieve pollutant reductions by methods other than those used in conventional treatment (sedimentation, activated sludge, trickling filter, etc.). Advanced treatment employs a number of different unit operations, including ponds, post-aeration, microstraining, filtration, carbon adsorption, membrane solids separation, and specific treatment processes such as phosphorus and nitrogen removal. This treatment is very effective in removing over 90 percent of organics and suspended solids. Low phosphorus and nitrogen can also be reached through advanced treatment.

#### 18-3. Sanitary waste system applications

Listed below are some of the fundamental processes with their applications.

*a. Preliminary.* Covers neutralization, equalization, screening, grit removal, temperature adjustment, and nutrient addition.

*b. Primary treatment.* Covers sedimentation and dissolved-air floatation.

*c. Secondary treatment.* Covers activated sludge (aeration and secondary sedimentation), aerated pond w/secondary sedimentation, aerobic-anaerobic ponds, trickling filter, chemical oxidation, chemical mixing flocculation and clarification, gravity filtration, pressure filtration, dissolved-air floatation w/chemicals, and anaerobic contact.

*d. Advanced wastewater treatment.* Covers activated carbon adsorption, micro straining filtration, land treatment, subsurface disposal, and ground water recharge.

*e. Sludge.* Covers anaerobic digestion, aerobic digestion, autoclaving, elutriation, vacuum filtration, centrifugation, sand beds, presses, incineration, wet oxidation, land disposal, and sanitary landfill.

#### **18-4. Treatment methods**

Listed below are some of the methods used in waste water treatment.

*a. Preliminary treatment.* This includes screening, grinding, grit removal, flotation, equalization, and flocculation. Screens, grinders and grit removal are provided for the protection of other equipment in the treatment plant. Air flotation and flocculation aid in the removal of suspended solids and oil in the primary clarifier and reduce the biological loading on secondary treatment processes. Pre-chlorination or pre-aeration may be required to prevent odor problems and to eliminate septic conditions where wastewater has abnormally long runs to the plant. Equalization structures are used to dampen diurnal flow variations and to equalize flows to treatment facilities.

(1) The primary function of bar screens is protection of downstream facilities rather than effective removal of solids from the plant influent.

(2) Comminuting devices are shredders that incorporate mechanisms that cut the retained material without removing it from the sewage flow. Comminutors are generally located between grit chambers and the primary settling tanks. Each comminuting device must have a bypass for maintenance and repair purposes. The bypass will include a bar screen, described as coarse screens.

(3) The primary purpose of grit chambers is to protect pumps and other mechanical equipment. Grit chambers will be located ahead of pumps and comminuting devices.

(4) Dissolved air flotation is a unit process whereby particulate matter is separated from a wastewater, causing the matter to float to the liquid surface.

(5) Flocculation units will be used and will immediately precede clarification units when a chemical precipitation process is employed as part of primary, secondary, or advanced wastewater treatment schemes.

(6) Dissolved air flotation is a unit process whereby particulate matter is separated from a wastewater, causing the matter to float to the liquid surface.

*b. Primary treatment.* The purpose of primary treatment is to remove solids that are not removed during preliminary treatment. Processes that provide primary treatment are primary sedimentation

(clarification) and Imhoff tanks. In most facilities, primary treatment is used as a preliminary step ahead of biological treatment.

(1) Sedimentation tanks allow solids to drop out of the wastewater. They usually take two forms. One is the rectangular tank with a minimum length of flow from inlet to outlet of 10 feet in order to prevent short circuiting of flow in the tank. In existing installations, tank length-to-width ratio varies between 3:1 and 5:1. Tanks will be designed with a minimum depth of 7 feet except final tanks in activated sludge plants, which will be designed with a 9-foot minimum depth. The other tank type is the circular tank. Circular tank diameters range from 25 to 150 feet. Side-water depths are 7 feet as a minimum, and tank floors are deeper at the center. A circular sludge-removal mechanism with peripheral speeds of 5 to 8 feet per minute will be provided for sludge collection at the center of the tank. Chemical precipitation may be introduced at this point to alleviate problems such as phosphorous, odor, industrial waste, or plant overload.

(2) Imhoff tanks provide removal of settleable solids and the anaerobic digestion of these solids in the same unit. They are two-level structures that allow the solids to settle out in the upper level. The settled solids then fall through slots into the lower level where they undergo digestion. The gas produced during digestion escapes through the vent areas along the sides of the upper level.

*c. Secondary treatment.* Secondary treatment is the use of secondary sedimentation tanks to allow the biological solids in the wastewater leaving the trickling filter to settle out. This produces an effluent for discharge, and the settled solids can be recirculated to the trickling filter to enhance its performance.

## 18-5. Typical sanitary waste systems

The following systems are used at the sites for waste treatment.

*a. Trickling filter process.* These have been justified by their low initial cost, low operating and maintenance costs, and relative simplicity of operation. Although the effluent from trickling filter plants of earlier design was of poorer quality than that from activated sludge plants, the performance of trickling filters designed more recently is comparable to that of activated sludge plants. Both processes offer certain advantages, with trickling filters providing good performance with minimal operator care and few, if any, energy requirements. An example of a typical trickling filter treatment process appears in figure 18-1. Although not shown, dual or parallel trains are appropriate for all treatment systems having a design capacity rating equal to or greater than 0.5 million gallons per day.

*b. Activated sludge process.* The activated sludge process is capable of meeting secondary treatment effluent limits. All designed processes will include preliminary treatment consisting of bar screen as a minimum and, as needed, comminutor, grit chamber, and oil and grease removal units. In a conventional (plug-flow) activated sludge plant (figure 18-2), the primary-treated wastewater and acclimated micro-organisms (activated sludge or biomass) are aerated in a basin or tank. After a sufficient aeration period, the flocculent activated sludge solids are separated from the wastewater in a secondary clarifier. The clarified wastewater flows forward for further treatment or discharge. A portion of the clarifier underflow sludge is returned to the aeration basin for mixing with the primary-treated influent to the basin and the remaining sludge is wasted to the sludge handling portion of the treatment plant.

c. *Stabilization pond process.* A wastewater stabilization pond is a relatively shallow body of wastewater contained in an earthen basin that is designed to treat wastewater. ("Oxidation pond" is a synonymous term.) They are used to treat a variety of wastewater's, from domestic wastewater to complex industrial waters, and they function under a wide range of weather conditions, i.e., tropical to arctic. Ponds can be used alone or in combination with other treatment processes. If sufficient land is available, ponds are a cost-effective means to provide wastewater treatment. In addition, their operation is easy and their maintenance requirements are minimal. Below are listed the different types of ponds.

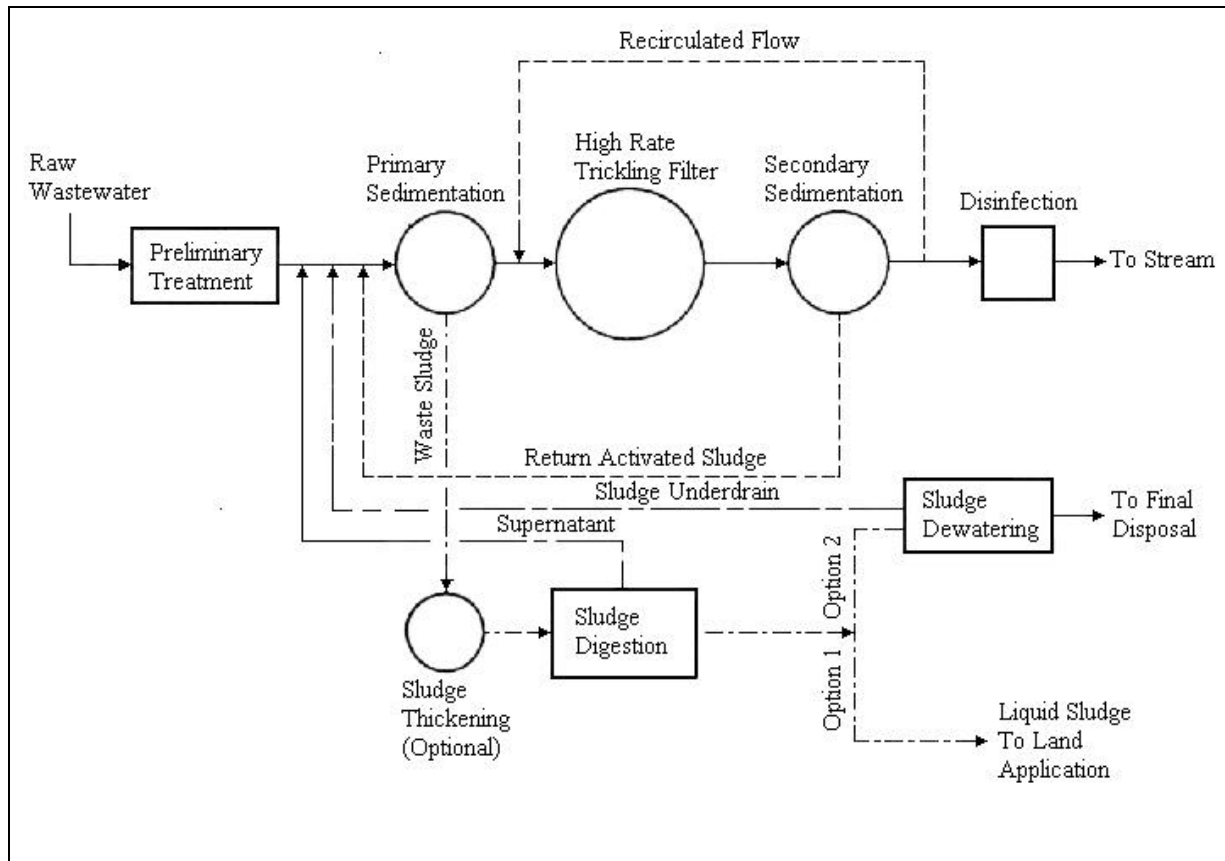

Figure 18-1. Typical trickling filter process treatment train

(1) An aerobic stabilization pond contains bacteria and algae in suspension; aerobic conditions (the presence of dissolved oxygen) prevail throughout its depth. There are two types of aerobic ponds:

(a) Shallow oxidation ponds obtain their dissolved oxygen via two phenomena: oxygen transfer between air and water surface, and oxygen produced by photosynthetic algae.

(b) An aerated pond is similar to an oxidation pond except that it is deeper and mechanical aeration devices are used to transfer oxygen into the wastewater.

(2) Three zones exist in an aerobic-anaerobic pond. They are the following.

(a) A surface zone where aerobic bacteria and algae exist in a symbiotic relationship;

(b) An anaerobic bottom zone in which accumulated solids are actively decomposed by anaerobic bacteria; and

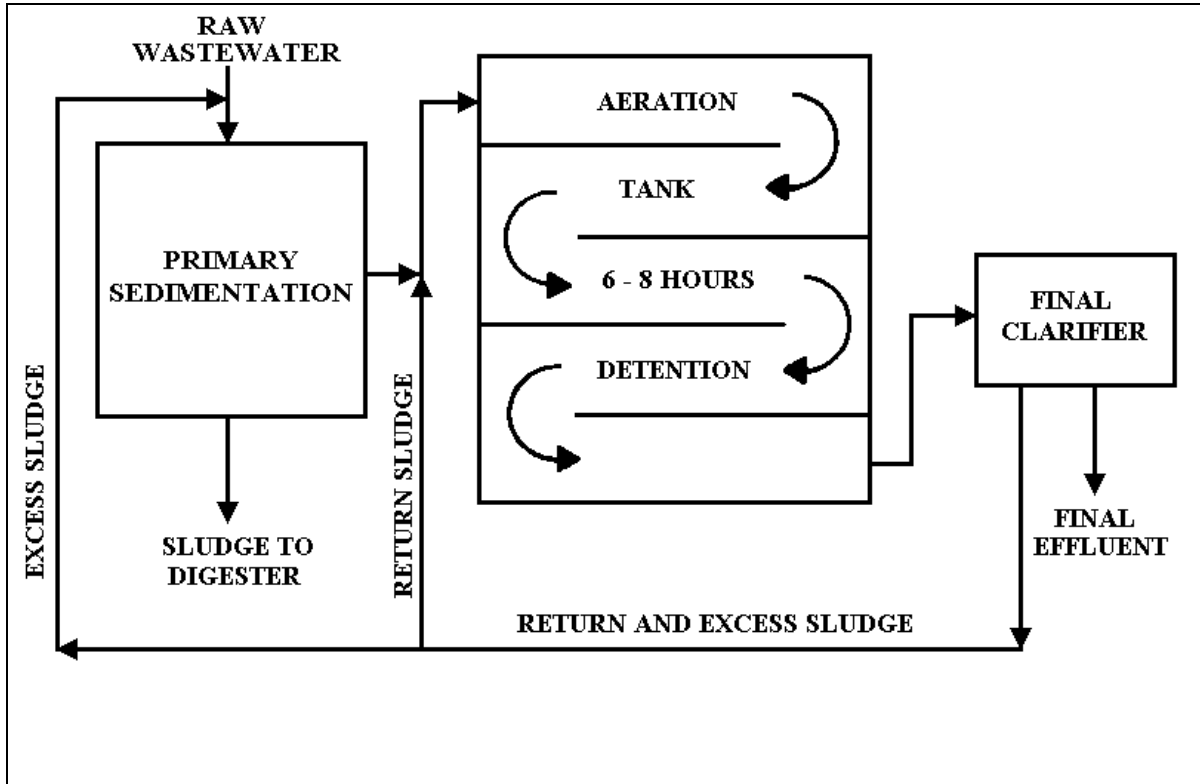

Figure 18-2. Conventional plug flow activated sludge flow diagram

(c) An intermediate zone that is partly aerobic and partly anaerobic in which the decomposition of organic wastes is carried out by facultative bacteria. In these ponds, the suspended solids in the wastewater are allowed to settle to the bottom. As a result, the presence of algae is not required. The maintenance of the aerobic zone serves to minimize odor problems because many of the liquid and gaseous anaerobic decomposition products, carried to the surface by mixing currents, are utilized by the aerobic organisms.

(3) Controlled discharge ponds have long hydraulic detention times and effluent is discharged when receiving water quality will not be adversely affected by the discharge. Controlled discharge ponds are designed to hold the wastewater until the effluent and receiving water quality are compatible.

(4) Complete retention ponds rely on evaporation and/or percolation to reduce the liquid volume at a rate equal to or greater than the influent accumulation.

d. *Advanced wastewater treatment processes.* A number of different unit operations are used in various configurations to make up an advanced wastewater treatment system. There are no advanced wastewater treatment process trains that can be considered typical or most applicable to a C4ISR installation. Effluent quality standards exceeding established secondary treatment level standards will

dictate the advanced treatment unit processes and their combinations that will provide the necessary degree of treatment. Unit operations typically used in advanced treatment are presented below.

(1) Wastewater treatment ponds may be used as a practical and economical method for upgrading existing secondary treatment facilities to obtain improved organic and suspended solids removal. Both aerobic and aerobic-anaerobic ponds can be used for this purpose. Ponds used for polishing purposes are subject to the same operating characteristics as those used for primary or secondary treatment, and the same precautionary design considerations must be applied.

(2) Post-aeration can be accomplished by diffused, cascade, U-tube, or mechanical aeration. Diffused aeration is carried out in tanks 9 to 15 feet deep and 10 to 50 feet wide (depth-to-width ratio is maintained at less than 2), with detention time of about 20 minutes. The maximum air requirement is approximately 0.15 cubic feet per gallon of wastewater treated. Mechanically aerated basins are 8 feet deep and require 15 to 50 square feet per aerator. The drop required for cascade aeration in a stepped-weir structure or in a rapidly sloping channel filled with large rocks or concrete blocks will depend on the desired oxygen uptake: 2 feet of drop will be provided for each milligram per liter of dissolved oxygen increase required.

(3) A microstrainer consists of a rotating drum supporting a very fine, stainless steel or plastic screen. Wastewater is fed into the inside of the drum and filters radially outward through the screen, with the mat of solids accumulating on the screen inside the drum. The solids are flushed into a removal trough at the top of the drum by a pressurized backwash system. From this trough, the solids are returned to the head of the system. Process effluent wastewater can be used for the backwash.

(4) The function of filtration is to remove as much of the suspended solids in the waste stream as possible through the use of filters. A filter consists of various sizes of media bounded by a container. Media in this case consists typically of different grades of sand, gravel, anthracite coal, etc. The effectiveness is derived from the type and size of filter media, depth of filter, amount of backwash, chemical pretreatment dosage, and filter rate and duration.

(5) Activated carbon adsorption beds can provide filtration but their primary function is to remove non-biodegradable organics, taste and odor compounds, and reduce color in the waste stream.

(6) Mineral addition and lime addition are the principal methods for in-plant removal of phosphorus from wastewater. The most commonly used of these metal salts are: alum, a hydrated aluminum sulfate, sodium aluminate, ferric sulfate, ferrous sulfate, ferric chloride, and ferrous chloride. Mineral addition is usually followed by anionic polymer addition, which aids flocculation; the pH may require adjustment depending on the particular process. In lime addition, phosphorus removal is attained through the chemical precipitation of hydroxyapatite. Addition can take place at the primary or secondary treatment stage.

(7) Land application systems are the use of land and biomass growth as a wastewater treatment area. Because land treatment of wastewater entails a higher risk than other treatment processes of introducing pathogenic micro-organisms and toxic chemicals into groundwater and surface water, land treatment system design must carefully consider all possible means to prevent water supply contamination.

(8) Soil biota are capable of stabilizing most organic wastes, including oily sludges. Today, only about 25 percent of sludges are spread on land; even less is composted. However, the organic materials in sludges are beneficial in restoring fertility to soils disturbed by mining, gravel operations, or poor



agricultural practices. There are, however, some major limitations. Concentrated sludges (if not composted or otherwise stabilized) placed on land should be immediately covered to prevent odor production and insect breeding. Sludges can be sliced or injected into soil or into stubble, using special equipment. Deep snow and deep frost will stop land spreading operations.

(9) Nitrification occurs in two steps: first NH is converted by Nitrosomonas bacteria; then converted by Nitrobacter bacteria. This process is limited by the relatively slow growth rate of Nitrosomonas.

(10) Denitrification is performed by heterotrophic anaerobic organisms and, therefore, requires an organic carbon source and anaerobic conditions. Suspended growth denitrification will provide gentle mixing (no aeration) with the mixed liquor being clarified. The effluent is aerated to provide dissolved oxygen and to drive off entrained nitrogen, and the sludge is recycled to the contact tank.

(11) Three-stage biological systems. Three-stage biological systems are essentially a combination of separate stage nitrification and denitrification. The advantage of this system is its flexibility of operation and the main disadvantage is the capital cost involved. This configuration also works to prevent short circuiting, which can be a problem in nitrification-denitrification when plug flow is not achieved.

(12) In anaerobic contact process, a further development of the high-rate digestion process allows separation and recycling of digested sludge solids. Like the activated sludge process, detention and mean cell residence times are controlled. Denitrification within these contact vessels approached 95 percent.

*e. Small installations.* Septic tanks, biological package treatment plants, and stabilization ponds are cost effective and require less operational and maintenance attention than other treatment options. Therefore, these treatment methods are especially applicable to C4ISR installations having design capacities of less than 100,000 gallons per day. See figures 18-3 through 18-6 for depictions of a septic tank, lift station, sewage ejector, and valves associated with these installations.

## **18-6. Sludge handling, treatment, and disposal**

Sludge, or residual solids, is the end product of wastewater treatment, whether biological or physical/chemical treatment. Primary sludge is from 3 to 6 percent solids. Treatment objectives are reduction of the sludge and volume, rendering it suitable for ultimate disposal. Secondary objectives are to utilize the generated gas if anaerobic digestion is selected as part of the sludge management strategy. In addition, an attempt should be made to sell/utilize the sludge as a soil conditioner rather than paying to dispose of it.

## **18-7. Disinfection**

Disinfection is a process in which pathogenic organisms are destroyed or inactivated. This process may be accomplished by physiochemical treatment or addition of chemical reagents. Improved coliform and virus removal can be obtained by utilizing flash mixing and acid feed for pH reduction. Chlorine, as liquid chlorine or in the form of chlorine compounds, is the most common chemical used to disinfect wastewater treatment plant effluents. Calcium hypochlorite or sodium hypochlorite will only be used as chlorinating agents for very small installations (less than 20,000 gallons per day). Ozone has been an effective disinfectant when used in the water treatment field, and its use as a disinfectant for wastewater is being

seriously considered. This interest has developed mainly because zoned effluents have normally shown no toxic effects on the receiving water biota as have residual chlorine compounds; however, for certain industrial wastes, epoxides have been found. The major disadvantage of ozonation is the high capital and operational cost associated with its generation.

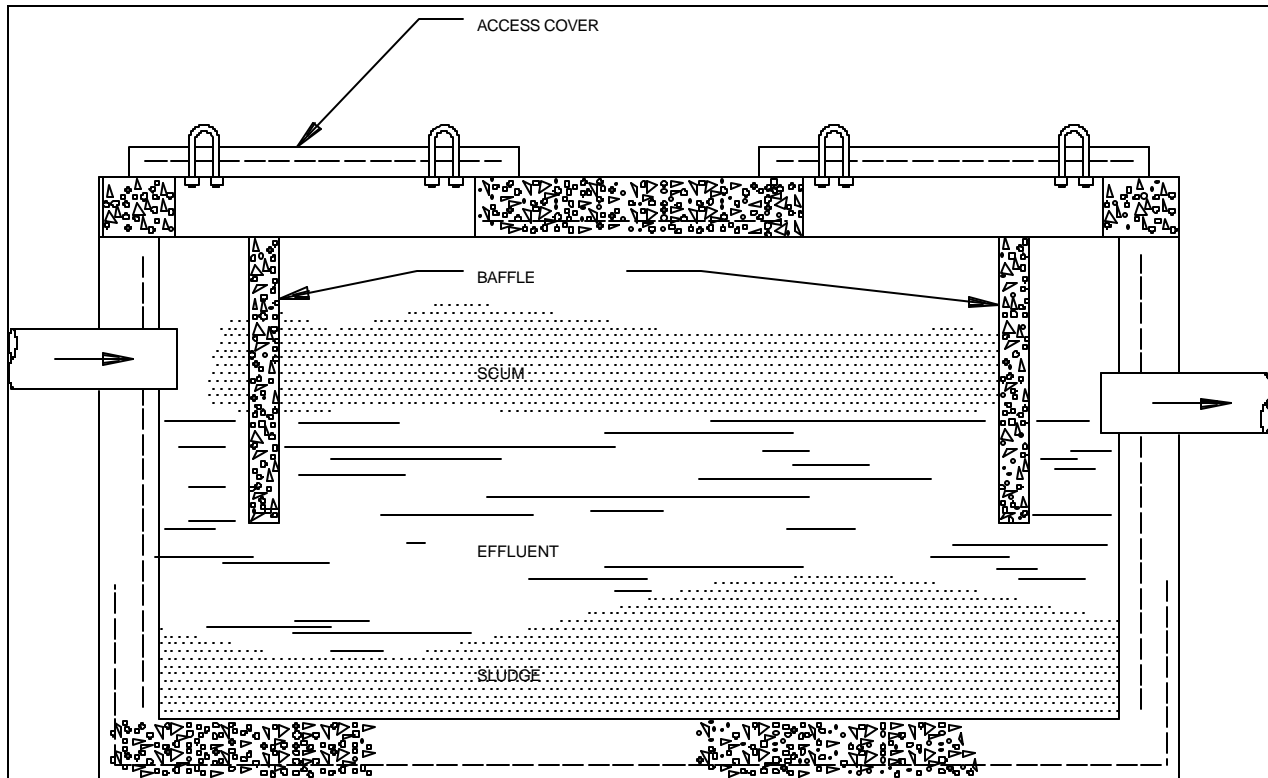

Figure 18-3. Septic tank

### 18-8. Flow measurement, sampling, and process control

Monitoring is required by Environmental Protection Agency (EPA) when National Pollutant Discharge Elimination System (NPDES) permits are issued to assure compliance with the permit. Additionally, certain operational monitoring is required to ensure that proper treatment plant performance is maintained. Below is a listing of the instrumentation used.

*a. Continuous recording of flow.* Wastewater flow rates will be monitored and recorded for purposes of evaluating treatment plant performance and will also be used when treatment changes are involved. Continuous flow measurement is necessary in order to monitor diurnal variations in flow which may affect treatment plant efficiency. Flow rates must also be taken into account when sampling wastewater quality.

*b. Types of flow measuring devices.* The following paragraphs describe the types that are suitable for use in wastewater treatment plants.

(1) Venturi meters are not to be used for measuring wastewater or sludge flow unless sufficient hydraulic head is available, or unless the Venturi tube is so constructed as to prevent solids accumulation at the upstream side of the throat. Clogging of the pressure tubes is avoided by providing cleanout taps and discharging a stream of fresh water through them into the sewer. Positive separation of potable water supply from this connection must be assured.

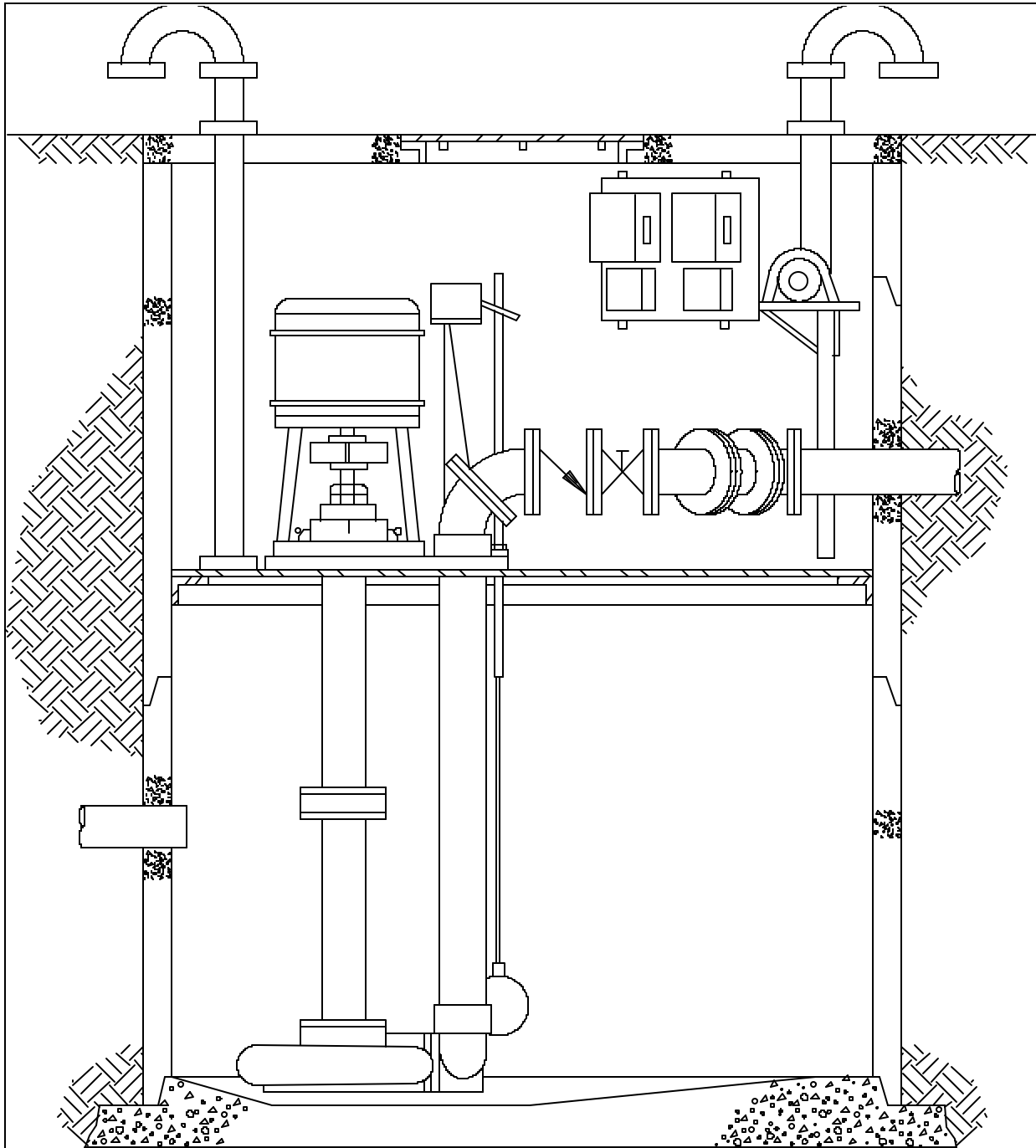

Figure 18-4. Lift station with wet pit vertical centrifugal pump

(2) Weirs will be located in a channel so that the flow will not be disturbed by turbulence and in such a manner that the depth of flow over the weir can be observed and recorded. When continuous recording is required, the float will be installed in a chamber separated from the main channel of flow but connected thereto by piping.

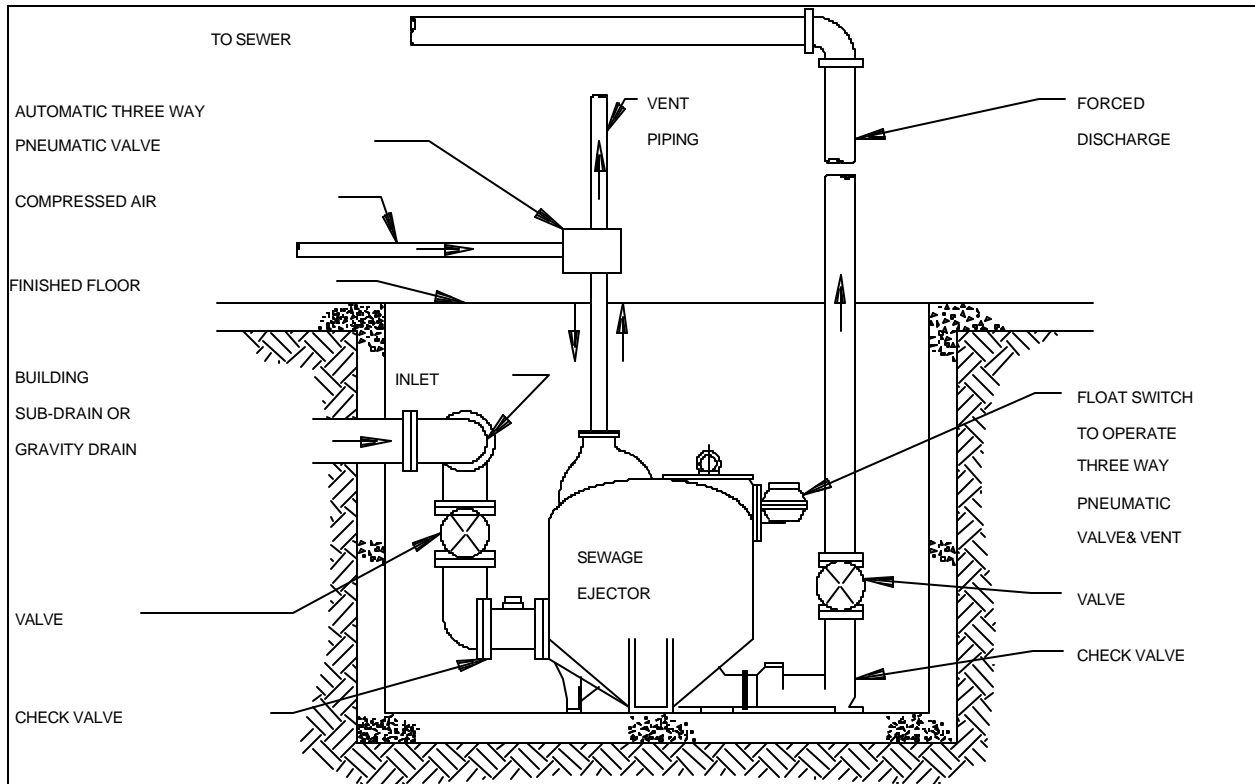

Figure 18-5. Pneumatic sewage ejector

(3) Parshall flumes have many advantages: the loss of head is minimal; it is self-cleaning; flow measurement can be made in open-channel flow; and it has no moving parts to malfunction. The downstream water-surface elevation above the flume approach floor must not exceed 65 percent of water elevation upstream of the flume. The flume will be designed with the narrowest throat practicable for the conditions under consideration. This is particularly important where a Parshall flume is utilized to control the velocity through a grit chamber.

(4) Magnetic flow meters can be used for flow measurement in wastewater treatment plants. There are many types of magnetic flow meters, however, and direct contact with the manufacturers is the quickest and generally most practical way to determine their application to specific wastewater measurements.

(5) Ultrasonic devices are being used to measure levels in Parshall flumes. A pulsing signal is bounced to the receiver where the level is related to the time elapsed. Since no components are in contact with the liquid, this device is applicable to many types of wastes and situations.

c. *Sampling.* Wastewater sampling at various points in the sewage treatment process is useful in evaluating operation efficiency. This can be used internally to optimize the process and is also used by

regulatory agencies to judge whether treatment plant regulations are satisfied. Sampling is also used to establish changes when treating industrial wastes. Provisions for sampling sites must be made in the plant design. The type of sampling provisions (flow proportional, composite, or grab-sample collection) will be dictated by the type of sampling required in any discharge permit. Forward flow, recycled flow, sludge flow, chlorine residual, pH and dissolved oxygen are some of the process control parameters that can be monitored on a continuous basis.

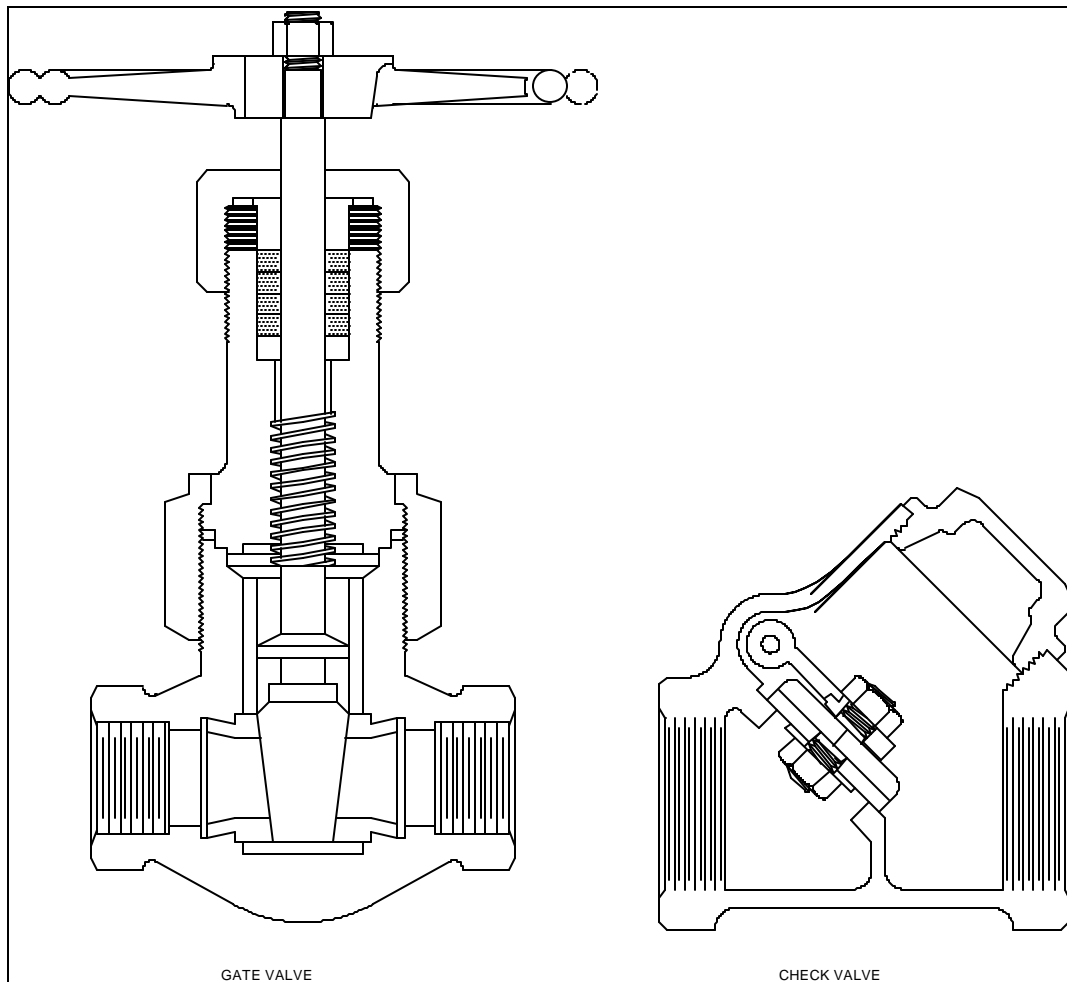

Figure 18-6. Gate valve and swing check valve

*d. Monitoring equipment for process control.* Monitoring equipment will be used to indicate and/or record flow quantities and, if justified, pressure, temperature, liquid levels, velocities, and various quality parameters such as dissolved oxygen, biochemical oxygen demand, total suspended solids, ammonia, nitrate, and pH.

(1) In sewage pumping stations, flow measurement is necessary to control periodic pump operation. Watt-hour meters and pump-time meters will be used to ensure uniform pump wear in multiple-pump installations.

(2) Monitoring primary treatment processes will require only flow measurement and recording and perhaps grit level monitoring. When digestion of the primary sludge follows, raw sludge flow rates must be monitored and controlled. In digestion, gas flow rates, tank pressures, and sludge temperatures will be monitored, and digester operation adjusted accordingly.

(3) Trickling filter monitoring will include flow measurement of influent, effluent and recirculation lines, and also volume of sludge pumped to or from the digesters. These parameters are used in determining and controlling hydraulic and organic loading as well as in controlling settling tank efficiencies. Activated sludge treatment will require the same monitoring with the addition of mixed-liquor, volatile suspended solids, and air supply monitoring.

(4) In sludge elutriation, sludge and elutriant flows will be measured in order to determine required sludge conditioner quantities. Sludge filtration will require measurements and control of sludge and sludge-cake flows and chemical feed rates. All chemical feed lines will be monitored and controlled, whatever their function. Sludge incineration and drying processes will require temperature monitoring at various points, pressure gauges, and sludge weighing equipment. Fuel flow rates, whether waste gas or auxiliary fuel, must be measured and controlled.

## CHAPTER 19

# GENERATORS

---

### 19-1. Generator usage

Electric generators are devices that convert energy from a mechanical form to an electrical form. This process, known as electromechanical energy conversion, involves magnetic fields that act as an intermediate medium.

*a. Generator types.* There are two types of generators: alternating current (AC) and direct current (DC). A generator may provide electrical power as the primary power source, standby power source, or emergency power source. It may be part of the primary electrical distribution system (above 600 volts) or part of the secondary distribution system (600 volts and below).

*b. Energy conversion.* The generator provides electrical power through the introduction of mechanical energy to a prime mover that takes this mechanical energy and converts it to electrical energy. Power companies accomplish this by using fossil and/or nuclear power to drive the prime mover. Large industrial sites can use their waste exhaust for such purposes. In addition, geothermal and wind turbines can also accomplish the same goal. However, for most Command, Control, Communications, Computers, Intelligence, Surveillance, and Reconnaissance (C4ISR) sites, diesel powered generators will provide the electrical energy on an as needed basis when local power is not available. The less volatile diesel fuel feeds the diesel engine that drives the prime mover. As the prime mover rotates, it drives the generator rotor causing magnetic lines of force to be cut by electrical conductors. Electrical energy is thereby produced by electromagnetic (EM) induction.

*c. Power generation.* The generator's operation is based on Faraday's law of EM induction. In brief, if a coil (or winding) is linked to a varying magnetic field, then an electromotive force (EMF), or voltage is induced across the coil. Thus, generators have two essential parts: one creates a magnetic field, and the other where the EMFs are induced. The magnetic field is typically generated by electromagnets (thus, the field intensity can be adjusted for control purposes), whose windings are referred to as field windings or field circuits. The coils where the EMFs are induced are called armature windings or armature circuits. One of these two components is stationary (stator), and the other is a rotational part (rotor) driven by an external torque. Conceptually, it is immaterial which of the two components is to rotate because, in either case, the armature circuits always "see" a varying magnetic field. However, practical considerations lead to the common design that for AC generators, the field windings are mounted on the rotor and the armature windings on the stator. In contrast, for DC generators, the field windings are on the stator and armature on the rotor.

### 19-2. Generator operation

A generator consists of a number of conducting coils and a magnetic field. The coils are called the armature. Relative motion between the coils and magnetic field induces voltage in the coils. This action is called EMF. An AC generator needs a separate DC source to feed the magnetic field. The required DC is provided by an external source called an exciter. Usually, the exciter is a small DC generator that is driven by the generator rotor. The exciter may be mounted on the rotor shaft or rotated by belt-drive. Some generating systems use a static, solid-state exciter to provide DC. A voltage regulator controls the

induced voltage by regulating the strength of the EM field established by the exciter. Frequency is controlled by the speed at which the prime mover rotates the rotor.

### 19-3. Generator types

Depending on the type of generating equipment employed, the electrical energy produced is either DC or AC.

*a. AC generators.* AC generators are considered either brush or brushless, based on the method used to transfer DC exciting current to the generator field. In addition, AC generators are classified as salient-pole or nonsalient-pole depending on the configuration of the field poles. Projecting field poles are salient-pole units and turbo-type (slotted) field poles are nonsalient-pole units.

*b. DC generators.* DC generators are classified as shunt, series, or compound wound. Most DC generators are the compound wound type. Shunt generators are usually used as battery chargers and as exciters for AC generators. Series generators are sometimes used for street lights. The EMF induced in a DC generator coil is alternating. Rectification is needed to direct the flow of current in one direction. The generator rotating commutator provides the rectifying action.

### 19-4. AC generators

AC generators are classified as single-phase or polyphase. Variations include three-phase generators used as single-phase units by insulating and not using one phase lead. Since the lead is unused, it is not brought out to a terminal. The kilowatt rating is reduced from that of the three-phase unit as limited by the amount of current carried by a coil. A generator designed only for single-phase operation usually does not have coils in all of the armature slots because end coils contribute little to the output voltage and increase the coil impedance in the same proportion as any other coil.

*a. Single-phase generators.* A single-phase generator is usually limited to 25 kW or less and generates AC power at a specific utilization voltage. Single-phase alternators are usually used in smaller systems. Terminal voltage is usually 120 volts. A variation is the three wire, single-phase alternator has three power terminals; one from each end of the armature coil and one from the neutral. Terminal voltage is usually 120 volts from the midpoint to either end of the armature coil and 240 volts between the two ends. The load is connected between the two outside wires or between either outside wire and neutral, depending upon the voltage required by the load.

*b. Polyphase generators.* Polyphase generators produce two or more alternating voltages (usually two, three, or six phases). Two-phase power is used in only a few localities. Six phase is primarily used for operation of rotary converters or large rectifiers. Three-phase alternators are the most widely used for power production. Polyphase alternators have capacities from 3 kW to 250,000 kW and voltage from 110 V to 13,800 V. Two general types of three-phase alternator windings are the delta winding used in three wire, three-phase alternators, and the star or wye winding used in four wire, three-phase types.

*c. Damper windings.* Damper windings on the rotor stabilize the speed of the AC generator to reduce hunting under changing loads. If the speed tends to increase, induction generator action occurs in the damper windings. This action places a load on the rotor, tending to slow the machine down. If the speed tends to decrease, induction motor action occurs in the damper winding, tending to speed the machine up. The windings are copper bars located in the faces of the rotor pole pieces. Mounted parallel to the rotor axis, the bars are connected at each end by a copper ring.



*d. Synchronous generators.* AC generators that operate at a speed that is exactly proportional to the frequency of the output voltage are synchronous generators. Synchronous generators are usually called alternators. Today, most electric power is produced by synchronous generators. Synchronous generators rotate at a constant speed, called synchronous speed. This speed is dictated by the operating frequency of the system and the machine structure. There are also AC generators that do not necessarily rotate at a fixed speed such as those found in windmills (induction generators); these generators, however, account for only a very small percentage of today's generated power.

(1) The rotor consists of a winding wrapped around a steel body. A DC current is made to flow in the rotor winding (or field winding), and this results in a magnetic field (rotor field). When the rotor is made to rotate at a constant speed, the three stationary windings experience a periodically varying magnetic field. Thus, EMF is induced across these windings. This EMF is AC and periodic; each period corresponds to one revolution of the rotor. Thus, for 60-Hz electricity, the rotor has to rotate at 3600 revolutions per minute (rpm); this is the synchronous speed of the given machine. Because the windings are displaced equally in space from each other (by 120 degrees), the EMF waveform is displaced in time by 1/3 of a period. The machine is therefore capable of generating three-phase electricity. The machine has two poles since its rotor field resembles that of a bar magnet with a north pole and a south pole.

(2) When the stator windings are connected to an external (electrical) system to form a closed circuit, the steady-state currents in these windings are also periodic. These currents create magnetic fields of their own. Each of these fields is pulsating with time because the associated current is AC; however, the combination of the three fields is a revolving field. This revolving field arises from the space displacements of the windings and the phase differences of their currents. This combined magnetic field has two poles and rotates at the same speed and direction as the rotor. In summary, for a loaded synchronous (AC) generator operating in a steady state, there are two fields rotating at the same speed: one is due to the rotor winding and the other due to the stator windings.

(3) It is important to observe that the armature circuits are in fact exposed to two rotating fields, one of which, the armature field, is caused by and in fact tends to counter the effect of the other, the rotor field. The result is that the induced EMF in the armature can be reduced when compared with an unloaded machine (i.e., open-circuited stator windings). This phenomenon is referred to as armature reaction. The EMF induced in a stator winding completes one period for every pair of north and south poles sweeping by; thus, each revolution of the rotor corresponds to two periods of the stator EMFs. If the machine is to operate at 60 Hz, then the rotor needs to rotate at 1800 rpm. In general, a  $p$ -pole machine operating at 60 Hz has a rotor speed of  $3600/(p/2)$  rpm. That is, the lower the number of poles is, the higher the rotor speed has to be. In practice, the number of poles is dictated by the mechanical system (prime mover) that drives the rotor.

(4) Steam turbines operate best at a high speed; thus, two- or four-pole machines are suitable. Machines driven by hydro turbines usually have more poles. Usually, the stator windings are arranged so that the resulting armature field has the same number of poles as the rotor field. In practice, there are many possible ways to arrange these windings. Geometry suggests that, at any time instant, equal EMFs are induced across the windings of the same phase. If the individual windings are connected in series, their EMFs add up to form the phase voltage.

*e. Auxiliary devices.* In addition to the basic components of a synchronous generator (rotor, stator, and their windings), there are auxiliary devices which help maintain the machine's operation within

acceptable limits. Three such devices are mentioned here: governor, damper windings, and excitation control system.

(1) A governor is to control the mechanical power input  $P_{in}$ . The control is via a feedback loop where the speed of the rotor is constantly monitored. For instance, if this speed falls behind the synchronous speed, the input is insufficient and has to be increased. This is done by opening up the valve to increase the steam for turbogenerators or the flow of water through the penstock for hydrogenerators. Governors are mechanical systems and therefore have some significant time lags (many seconds) compared to other EM phenomena associated with the machine. If the time duration of interest is short, the effect of governor can be ignored in the study; that is,  $P_{in}$  is treated as a constant.

(2) Damper windings (armortisseur windings) are special conducting bars buried in notches on the rotor surface, and the rotor resembles that of a squirrel-cage-rotor induction machine. The damper windings provide an additional stabilizing force for the machine when it is perturbed from an equilibrium. As long as the machine is in a steady state, the stator field rotates at the same speed as the rotor, and no currents are induced in the damper windings. That is, these windings exhibit no effect on a steady-state machine. However, when the speeds of the stator field and the rotor become different (because of a disturbance), currents are induced in the damper windings in such a way as to keep the two speeds from separating.

(3) Modern excitation systems are very fast and quite efficient. An excitation control system is a feedback loop that aims at keeping the voltage at machine terminals at a set level. From a system viewpoint, the two controllers of excitation and governor action rely on local information (machine's terminal voltage and rotor speed). In other words, they are decentralized controls. For large-scale systems, such designs do not always guarantee a desired stable behavior since the effect of interconnection is not taken into account in detail.

*f. Induction generators.* A three-phase induction machine is similar to a synchronous machine, but the former has a much simpler rotor circuit. A typical design of the rotor is the squirrel-cage structure, where conducting bars are embedded in the rotor body and shorted out at the ends. When a set of three-phase currents (waveforms of equal amplitude, displaced in time by one-third of a period) is applied to the stator winding, a rotating magnetic field is produced. Currents are therefore induced in the bars, and their resulting magnetic field interacts with the stator field to make the rotor rotate in the same direction. In this case, the machine acts as a motor since, in order for the rotor to rotate, energy is drawn from the electric power source.

(1) When the machine acts as a motor, its rotor can never achieve the same speed as the rotating field (this is the synchronous speed) for that would imply no induced currents in the rotor bars. If an external mechanical torque is applied to the rotor to drive it beyond the synchronous speed, however, then electric energy is pumped to the power grid, and the machine will act as a generator.

(2) An advantage of induction generators is their simplicity (no separate field circuit) and flexibility in speed. These features make induction machines attractive for applications such as windmills.

(3) A disadvantage of induction generators is that they are highly inductive. Because the current and voltage have very large phase shifts, delivering a moderate amount of power requires an unnecessarily high current on the power line. This current can be reduced by connecting capacitors at the terminals of the machine. Capacitors have negative reactance; thus, the machine's inductive reactance can be

compensated. Such a scheme is known as capacitive compensation. It is ideal to have a compensation in which the capacitor and equivalent inductor completely cancel the effect of each other. In windmill applications, for example, this faces a great challenge because the varying speed of the rotor (as a result of wind speed) implies a varying equivalent inductor.

### 19-5. DC generators

To obtain DC electricity, one may prefer an available AC source with an electronic rectifier circuit. Another possibility is to generate DC electricity directly. Although the latter method is becoming obsolete, it is still important to understand how a DC generator works. As in the case of AC generators, a basic design will be used to explain the essential ideas behind the operation of DC generators.

*a. Basic theory.* The stator of the simple machine is a permanent magnet with two poles labeled N and S. The rotor is a cylindrical body and has two (insulated) conductors embedded in its surface. At one end of the rotor the two conductors are connected to a pair of copper segments; these semicircular segments are mounted on the shaft of the rotor. Hence, they rotate together with the rotor. At the other end of the rotor, the two conductors are joined to form a coil. Assume that an external torque is applied to the shaft so that the rotor rotates at a certain speed. The rotor winding formed by the two conductors experiences a periodically varying magnetic field, and hence an EMF is induced across the winding.

*b. Commutation.* This voltage periodically alternates in sign, and thus, the situation is conceptually the same as the one encountered in AC generators. To make the machine act as a DC source, viewed from the terminals, some form of rectification needs be introduced. This function is made possible with the use of copper segments and brushes. Each copper segment comes into contact with one brush half of the time during each rotor revolution. The placement of the (stationary) brushes guarantees that one brush always has positive potential relative to the other. For the chosen direction of rotation, the brush with higher potential is the one directly beneath the N-pole. (Should the rotor rotate in the reverse direction, the opposite is true.) Thus, the brushes can serve as the terminals of the DC source. In electric machinery, the rectifying action of the copper segments and brushes is referred to as commutation, and the machine is called a commutating machine.

*c. DC voltage.* The voltage across the unloaded terminals is not a constant. A unidirectional current can flow when a resistor is connected across the terminals of the machine. The pulsating voltage waveform generated by the simple DC machine usually cannot meet the requirement of practical applications. An improvement can be made with more pairs of conductors. These conductors are placed in slots that are made equidistant on the rotor surface. Each pair of conductors can generate a voltage waveform but there are time shifts among these waveforms due to the spatial displacement among the conductor pairs. For instance, when an individual voltage is minimum (zero), other voltages are not. If these voltage waveforms are added, the result is a near constant voltage waveform. This improvement of the DC waveform requires many pairs of the copper segments and a pair of brushes.

*d. Armature reaction.* When the generator is connected to an electrical load, load currents flow through the rotor conductors. Therefore, a magnetic field is set up in addition to that of the permanent magnet. This additional field generally weakens the magnetic flux seen by the rotor conductors. A direct consequence is that the induced EMF is less than those in an unloaded machine. Similar to the case of AC generators, this phenomenon is referred to as armature reaction, or flux-weakening effect.

*e. Brushes.* The use of brushes in the design of DC generators can cause a serious problem in practice. Each time a brush comes into contact with two adjacent copper segments, the corresponding conductors are short-circuited. For a loaded generator, such an event occurs when the currents in these conductors are not zero, resulting in flashover at the brushes. This means that the life span of the brushes can be drastically reduced and that frequent maintenance is needed. A number of design techniques have been developed to mitigate this problem.

*f. Excitation.* The stator winding is called the field winding, which produces excitation for the machine. The current in the field winding is adjusted by means of a variable resistor connected in series with this winding. It is also possible to use two field windings in order to have more flexibility in control. The use of field winding(s) on the stator of the dc machine leads to a number of methods to produce the magnetic field. Depending on how the field winding(s) and the rotor winding are connected, one may have shunt excitation, series excitation, etc. Each connection yields a different terminal characteristic.

### 19-6. Major design components

A typical AC generator consists of a stationary stator and a rotor mounted within the stator. The stator contains a specific number of coils, each with a specific number of windings. Similarly, the rotor consists of a specific number of field poles, each with a specific number of windings. In addition to the rotor and stator, a generator has a collector assembly (usually consisting of collector slip rings, brushes, and brush holders). DC flows from the exciter, through the negative brush and slip ring, to the rotor field poles. The return path to the exciter is through the positive brush and slip ring.

*a. Rotor.* The rotor contains magnetic fields that are established and fed by the exciter. When the rotor is rotated, AC is induced in the stator. The changing polarity of the rotor produces the alternating characteristics of the current. The generated voltage is proportional to the strength of the magnetic field, the number of coils (and number of windings of each coil), and the speed at which the rotor turns.

*b. Stator.* The frame assembly is the main component of the stator. Insulated windings (or coils) are placed in slots near an air gap in the stator core. There is a fixed relationship between the unit's number of phases and the way the coils are connected. The stator in a four wire, three-phase unit has three sets of armature coils which are spaced 120 electrical degrees apart. One end of each coil is connected to a common neutral terminal. The other end of each coil is connected to separate terminals. Conductors attached to the four terminals carry the current to the system's switchgear and on to the load.

*c. Collector slip rings.* Slip rings are usually made of non-ferrous metal (brass, bronze or copper); iron or steel is sometimes used. Slip rings usually do not require much servicing. The wearing of grooves or ridges in the slip rings is retarded by designing the machine with limited endplay and by staggering the brushes. Surfaces of the slip rings should be bright and smooth; polishing can be performed with fine sandpaper and honing stone. Electrolytic action can occur at slip ring surfaces producing formation of verdigris. Verdigris is a greenish coating that forms on non-ferrous metals. Electrolytic deterioration can be prevented by reversing the polarity of the slip rings once or twice a year. The stator of the three wire, three-phase unit also has three sets of armature coils spaced 120 electrical degrees apart. The ends of the coils are connected together in a delta configuration. Conductors are attached to the three connecting points.

*d. Exciters.* An AC or DC generator requires direct current to energize its magnetic field. The DC field current is obtained from a separate source called an exciter. Either rotating or static -type exciters

are used for AC power generation systems. There are two types of rotating exciters: brush and brushless. The primary difference between brush and brushless exciters is the method used to transfer DC exciting current to the generator field. Static DC excitation for the generator fields is provided in several forms including field flash voltage from storage batteries and voltage from a system of solid-state components. DC generators are either separately excited or self excited

*e. Field flashing.* Field flashing is required when generator voltage does not build up and the generating system (including the voltage regulator) does not have field flash capability. This condition is usually caused by insufficient residual magnetism in the exciter and generator fields. In some cases, a generator that has been out of service for an extended period may lose its residual magnetism and require flashing. Residual magnetism can be restored by flashing the field, thereby, causing a current surge in the generator. Refer to the voltage regulator manufacturer's literature for procedural instructions. Solid-state components may be included in the voltage regulator. Perform field flashing according to the manufacturer's instructions to avoid equipment damage.

## CHAPTER 20

### PRIMARY ELECTRICAL DISTRIBUTION

---

#### 20-1. General primary electrical distribution

Primary electrical distribution system is defined in this manual to be the electrical system operating above 600 Vac. Secondary distribution system is defined as 600 Vac and below. Without electrical power to operate equipment, provide illumination, etc., site operations would be very difficult or impossible; therefore, correct operation and maintenance of the primary electrical distributions system is essential.

#### 20-2. Substations

Substations control the flow of power into a facility. They are comprised of transformers for stepping down the voltage, high-voltage insulators, and large air/oil circuit breakers capable of interrupting tremendous amounts of current during fault conditions.

*a. Transformers.* A transformer utilizes electromagnetic (EM) induction between circuits of the same frequency, usually with changed values of voltage and current. Transformers can be classified in various ways, but their basic construction consists of windings, magnetic cores on which windings are coiled, insulation, and any special connections applying to the type of load. Substation transformers can range in size from a garbage can to a small house. Their main purpose is to transform alternating voltage and current from one level to another. At the power plant the voltage is brought up to a higher voltage for efficiency in transmitting the power to the end user. At the end user's locale the voltage is brought down to a level that is suitable for operations.

(1) The basic design of a transformer consists of electrical coils wrapped around an iron or steel core. By controlling the number of windings, or tapping into the windings, various levels of voltage change can occur. Nameplate information for each transformer will help in identifying the primary coil and the secondary coil ratings, in addition to how the transformer is configured.

(2) Transformers rated above 500 kVA are classed as power transformers. Transformers rated at 500 kVA or less are classed as distribution transformers, as they usually have low tension windings of less than 600 volts.

(3) American National Standards Institute/Institute of Electrical and Electronic Engineers (ANSI/IEEE) C57.12.80, Standard Terminology for Power and Distribution Transformers 91992), identifies several classes of insulation systems for power and distribution transformers. Insulation classifications are based upon the insulation's temperature rating and the method of cooling needed to remove the heat from the transformer. The core and the coils of dry type transformers are in a gaseous or dry-compound insulating material. The core and the coils of liquid-immersed transformers are contained in an insulating liquid. A flammable mineral oil insulation is the most frequently used liquid. Various less flammable liquids are used to meet National Electrical Code (NEC) code requirements. Only flammable and less flammable liquids are acceptable on military installations. Non-flammable insulated liquids, though available, are not considered environmentally acceptable. Polychlorinated biphenyl (PCB) insulated transformers should be removed to meet Environmental Protection Agency (EPA) requirements. Replacement of liquid-filled transformers in or near buildings must take into account the latest applicable NEC code restrictions, which might require an existing installation to be modified or a different type of insulating medium to be provided.

(4) An outdoor transformer is constructed of weather-resistant construction, suitable for service without additional protection from the weather. Industry standards also classify transformers as indoor units, which must be protected from the weather. A pole type transformer is an outdoor transformer that is suitable for mounting on a pole or a similar structure. A pad-mounted transformer is a unitized or compartmental type transformer, with enclosed compartments for medium-voltage and low-voltage cables entering from below, and is mounted on a pad.

(5) Transformers can maintain an acceptable voltage ratio of about a 2 percent voltage drop from zero to rated output in most cases. Most distribution transformers and smaller power transformers have tapped windings, which permit adjusting the output voltage to broaden the range of primary voltage inputs. The transformer will have a manual tap changer, which can be operated if the transformer is de-energized. However, on substations which serve varying loads, such as pumping facilities, or on large installations with long primary feeder lines, taps may not provide sufficient voltage regulation and other means are necessary.

(6) An automatic load tap changing (LTC) feature installed on a transformer provides automatic tap changing under load, and normally varies the voltage to plus or minus 10 percent of the system's rated voltage by changing tap connections using a motor-driven, tap-changing switch.

(7) Sometimes voltage regulation is needed and the system transformers do not include the LTC feature. Voltage regulators are used to supply the control for the variations in load. A voltage regulator needs similar servicing to that required for a power transformer. A step-voltage regulator operates on the same principal as the LTC mechanism. An induction voltage regulator has a series winding and a shunt winding, and uses a motor to rotate the shunt winding to either add to (boost) or subtract from (buck) the series winding voltage. The action provided is dependent upon the voltage induced in the series winding and the respective polarities of each winding (that is, the respective instantaneous directions of currents entering the primary and leaving the secondary terminals during most of each half cycle). The switching mechanism in most new voltage regulators is practically maintenance free, but many of the older units require considerable servicing. The manufacturer's recommendations should be followed for all maintenance and servicing requirements.

*b. Insulators.* The function of an insulator is to support a conductor or conducting device safely. An insulator, being of a non-conductive material, physically and electrically separates the supported item from any grounded or energized conductors or devices. Insulators are composed of porcelain, glass, fiberglass, or a composite compound. Maintenance is necessary to preserve their insulating ability that can be degraded by contamination or other damaging actions. Most insulator damage will result from gun shots; lightning, surge, or contamination flashovers; and wind damage. Defective insulators can also cause visible corona or interference voltage propagation.

*c. Bushings.* A bushing is an insulating structure that provides a conducting path through its center while its body isolates contact to the support structure. A bushing has a provision for mounting on a barrier (conducting or otherwise). The bushing insulates the conductor from the barrier and conducts current from one side of the barrier to the other side. The primary function of a bushing is to provide an insulated entrance for an energized conductor into an apparatus tank.

*d. Instrument transformers.* Current and potential (voltage) transformers are used to enable ammeters and wattmeters to monitor power conditions. An instrument transformer is designed to reproduce in its secondary circuit (in a definite and known proportion) the current or voltage of its primary circuit with the phase relations and waveform substantially preserved.

(1) A current transformer is a constant-current transformer that reduces line currents into values

suitable for standard measuring devices such as ammeters and wattmeters and standard protective and control devices. It also isolates these devices from line voltages. The primary winding is connected in series with the circuit carrying the line current, or as a window type arrangement linked magnetically with the line conductor which eliminates the need for an integral primary winding.

(2) A potential transformer is basically a conventional constant-voltage transformer with primary and secondary windings on a common core connected in shunt or parallel to the power supply circuit to be measured or controlled. The secondary winding insulates devices from the power circuit.

*e. Switches.* Substation switches can be operated manually or power operated. Insulation for the voltage and current interrupting level may be provided by operating the contacts in air, oil, vacuum, or in a sulfur hexafluoride (SF<sub>6</sub>) gas medium. Switches are classified by their ability to interrupt load.

(1) A disconnecting switch is a device used to open, close, or change the connections in a circuit or system. It has no interrupting rating and is used for isolating equipment only after the circuit has been opened by some other means. Two special types are as follows.

(2) A grounding switch is a switch used to connect a circuit or piece of equipment to ground.

(3) A horn-gap switch is a switch provided with arcing horns to aid in dispersing any arc that may occur when the switch is operated. This combination is sometimes referred to as an air-break switch. It should not be operated except to interrupt the charging current of a short length of line, or the magnetizing current of a de-energized transformer. Oil switches should always be considered as disconnect switches, unless the switch nameplate indicates a fault closing rating suitable for the system's maximum available fault.

(4) Interrupter switches have specific capabilities for switching one or more of the following type of loads: 0.8 minimum lagging power factor load, parallel or loop load, transformer magnetizing load, line charging load, cable charging load, and capacitor bank load. Follow the manufacturer's instructions when operating interrupter switches.

(5) Non-fault closing type switches are equipped with means of interrupting current, at rated voltage, not in excess of the switch's continuous rated current. Interrupter switches, which do not have a fault-closing rating, may be damaged if inadvertently closed on a short circuit. Appropriate precautions should be taken to avoid danger to the operator.

(6) Fault closing type switches are equipped with means for interrupting current, at rated voltage, in excess of the switch's continuous rated current. Interrupter switches with fault-closing ratings are intended to provide adequate personnel protection, when closing into a short circuit, up to the asymmetrical fault-closing rating of the switch and when applied in accordance with the manufacturer's recommendation.

*f. Bus structures.* A bus structure is an assembly of bus conductors with associated connection joints and insulating supports. It can have bare or insulated conductors. A busway is a grounded metal enclosure, containing factory-mounted bare or insulated conductors, that are usually copper or aluminum bars, rods, or tubes. Each serves as a common connection between two or more circuits.

### 20-3. Overhead distribution

Overhead electrical distribution at all voltages most often uses open wire construction, although aerial



cables of various types are employed to some extent. Poles, towers, and other supporting structures define overhead distribution. When several different voltages are found on these structures the hierarchy is the highest voltage is at the top. Voltages drop as the circuits descend downward.

*a. Open wire construction.* The basic features of open wire construction are single conductors, insulated supports, and wide separation, with little or no conductor covering on the conductors. The air space around the conductors must be large enough to allow relative conductor movement without a flashover. Open wire construction is mounted on insulators, either as armless or crossarm construction.

*b. Armless construction.* Armless construction consists of insulators on supporting brackets mounted directly on the pole. When possible, this construction is preferred for use on pole replacements because of its more attractive appearance and lower maintenance cost. Triangular tangent construction is preferred over vertical tangent construction, as it requires the least conductor space and is more economical. Triangular construction is not suitable for configurations that require an overhead ground wire. It is not recommended except for the tangent and minor angle construction.

*c. Poles.* Poles are constructed of wood, metal, or concrete. Extending out from these structures are crossarms that support the overhead cable. The poles can be self-supporting or may require guys (stranded galvanized wire) or braces to hold the pole in position.

*d. Crossarm construction.* Unless it conflicts with facility practice, crossarm construction should be phased out whenever possible, but may be necessary where equipment or line installations, utilizing armless construction, would result in excessive pole heights. Facility practice usually matches the local utility company's open wire construction.

*e. Overhead cable.* Aerial cable has its individual conductors insulated and supported by a messenger (support wire) along its length. The cable is then lashed and clamped to the insulators mounted on the poles or towers.

*f. Overvoltage protection.* Overhead lines are extremely vulnerable to direct strokes or to induced voltage influences. Underground systems derived from aerial lines may also be affected. Lightning results from the potential difference between clouds or between a cloud and earth. A lightning stroke may be in direct contact with an electric line and equipment. The charged clouds of a passing lightning storm may also cause an electrostatically induced voltage.

(1) The high voltage of a lightning surge, imposed on lines and devices without surge protection, will flash over the insulation in the majority of cases. Where flashover occurs, through air or on insulators, it rarely causes permanent damage, but flashover occurring through the solid insulation on equipment or cable can result in permanent damage.

(2) A surge limiting protective device must limit transient over-voltages or surge voltages that could damage apparatus. The device must bypass the surge to ground and discharge severe surge currents of high magnitude and long duration without injury. The device must continuously withstand the rated power voltage for which it is designed. The device's protective ratio is the maximum surge voltage it will discharge, compared to the maximum crest power voltage it will withstand following discharge. Surge arresters provide the most accepted method of surge limiting protection, since they provide the highest degree of surge elimination. Other methods include shielding lines and equipment from direct lightning strokes; and providing devices designed to divert or change the waveform of the surge, such as protective gaps, surge capacitors, and bypass resistors. A surge arrester is a protective device for limiting surge

voltages on equipment by discharging or bypassing surge current. Surge arresters allow only minimal flow of the 60 hertz power current to ground. After the high-frequency lightning surge current has been discharged, a surge arrester, correctly applied, will be capable of repeating its protective function until another surge voltage must be discharged.

(3) Surge arresters used for protection of exterior electrical distribution lines will be either of the metal-oxide or gapped silicon-carbide type. Expulsion type units are no longer used.

## 20-4. Switchgear

Switchgear is a general term covering switching and interrupting devices that control, meter, and protect the flow of electric power. The component parts include circuit breakers, instrument transformers, transfer switches, voltage regulators, instruments, and protective relays and devices. Switchgear includes associated interconnections and supporting or enclosing structures. The various configurations range in size from a single panel to an assembly of panels and enclosures. The latter is normally constructed into cubicles with a circuit interrupter in one and auxiliary equipment in the others. It is then normally connected to a transformer. Equipment rated up to 1000 volts alternating current (AC) is classed as low voltage. Equipment equal to or greater than 1000 volts but less than 100,000 volts AC is classed as medium voltage.

*a. Medium voltage switchgear.* Major elements of medium voltage switchgear are circuit breakers, potential transformers, current transformers, and control circuits. Construction of circuit breakers employed in the two types of switchgear and the methods to accomplish breaker tripping are the primary differences. The service entrance conductors and main bus are typical heavy-duty conductors rated for use between 601 volts AC and 38,000 volts AC, as required.

*b. Circuit interrupters.* These interrupters can be air circuit breakers, arc interrupters, vacuum circuit breakers, or oil circuit breakers. Some can be removed from their cubicle while others must be checked in place.

*c. Fuses.* High voltage fuses can provide current or non-current limiting features. Their use can be dictated by the manufacturer or end user requirements. Available types are sand filled, liquid filled, or vented expulsion type.

*d. Lightning (surge) arrestors.* Arrestors are provided to pass high energy surges directly to ground thereby protecting the other electrical equipment downstream.

*e. Protective relays.* Protective relays provide quick isolation of power systems under fault conditions. They can detect overcurrent, overvoltage, under-voltage, current balance, current flow, frequency, and impedance.

*f. Alarms.* Various alarms available are transformer over temperature, high or low pressure, circuit breaker trip, ground fault, or switchgear over temperature.

*g. Interlocks.* Interlocks are provided for personnel safety to prevent operation of equipment in an unsafe manner.

## 20-5. Circuit breakers

Circuit breakers are a special form of switching mechanism, which can open and close circuits under both normal and abnormal conditions. When they are electrically controlled, they can be operated locally or remotely, or by both modes. Oil, SF<sub>6</sub>, vacuum, and air are the insulating mediums used on most installations. The selection of the insulation generally relates to the voltage level being interrupted. Usually the air circuit breakers have draw-out construction. This feature permits removal of an individual breaker from the switchgear enclosure for inspection or maintenance without de-energizing the main bus.

*a. High-voltage breakers.* Until recently most installed high-voltage circuit breakers were of the oil-insulated type. However, the use of SF<sub>6</sub> gas insulated units is increasing as these take less space for a given voltage and are environmentally preferable.

*b. Medium-voltage breakers.* Newly installed medium-voltage switchgear utilizes vacuum construction which provides a considerable space saving over air-magnetic units.

## CHAPTER 21

### SECONDARY ELECTRICAL DISTRIBUTION

---

#### 21-1. General secondary electrical distribution

A secondary electrical distribution system is defined as an electrical distribution system having a voltage of 600 Vac and below. This is the electrical system that normally supplies power to process systems, habitability systems, and other loads within a facility. Typical equipment and components that comprise this system are switchgear, switchboards, and panelboards; transformers; power line conditioners; motor control centers; protective devices, fuses and circuit breakers; switches; feeder cables; and controls.

#### 21-2. Switchgear, switchboards, and panelboards

Switchgear, switchboards, and panelboards are general terms covering switching and interrupting devices that control, meter and protect the flow of electric power. The component parts include circuit breakers, fuses, instrument transformers, transfer switches, voltage regulators, instruments, and protective relays and devices. The various configurations range in size from a single panel to an assembly of panels and enclosures. The components comprising the makeup of the main devices are usually in a grounded, metal enclosure. Equipment rated up to 1000 volts alternating current (AC) is classed as low voltage. Equipment equal to or greater than 1000 volts but less than 100,000 volts AC is classed as medium voltage.

#### 21-3. Transformers

A transformer utilizes electromagnetic (EM) induction between circuits of the same frequency, usually with changed values of voltage and current. Transformers can be classified in various ways, but their basic construction consists of windings, magnetic cores on which windings are coiled, insulation, and any special connections applying to the type of load. Transformers used for secondary distribution are usually smaller than those for primary distribution, but depending on the voltage and demand can be large. Their main purpose is to transform alternating voltage and current from one level to another. At the secondary distribution point the voltage is brought down to a level that is suitable for operations. Small power transformers sometimes supply power to loads where continuity of service is critical and therefore a greater degree of attention is justified. While the percentage of transformer failures is low, failures that do occur are serious and result in extensive downtime and expense. The best assurance of continued high reliability is regular maintenance procedures. Transformers require very little attention when compared to most electrical apparatus. For a complete description of transformers see chapter 20.

#### 21-4. Power line conditioners

Power line conditioning is often used to improve the quality of power for special applications such as computers. Although it is difficult to make any generalizations concerning the benefits that accrue from the use of line protective equipment, it has been estimated that clean power versus that taken directly from the “average” power line reduces load equipment outages by 40 percent and maintenance costs by 25 percent. The choice to use protective equipment is both an economic and technical consideration.

*a. Isolation transformers.* Isolation transformers are primarily intended to attenuate common-mode impulses. Some types also provide limited attenuation of normal mode impulses. Isolation transformers

perform no voltage regulating function. Sags, surges, under voltages, or over voltages will be reproduced faithfully on the transformer secondary. If the power line voltage is consistently stable and high-frequency impulses or noise is the only problem, then a suitable isolation transformer may eliminate power line disturbance difficulties.

*b. Line voltage regulators.* Line voltage regulators do exactly what the name implies – their purpose is to maintain reasonably constant output voltage to the load in the face of variations in power line voltage. There are many different ways of accomplishing this and among the basic types there are innumerable variations, all with their own advantages and limitations.

*c. Line conditioners.* Line conditioners combine the functions of isolation transformers and line voltage regulators and thus both attenuate impulses and regulate output voltage. For this reason, a line conditioner can protect against the principal types of power line disturbances except for voltage dropouts and line interruptions. It is possible to create a line conditioner by placing separate voltage regulators and isolation transformers in series. Properly matching the two can be tricky, and the package is bulkier and generally more expensive than using a single unit designed to perform the total line conditioning function.

*d. Motor-generator sets.* Motor-generator sets consist of a motor driving an AC generator or alternator so that the load is completely electrically isolated from the power line. In the past, direct current (DC) or induction drive motors were used requiring close speed control to maintain stable frequency to the load. The tendency nowadays is to use synduction or synchronous motors. The synduction motor resembles an induction motor but runs at synchronous speed. With either of these unit types, alternator speed and thus frequency to the load is as stable as power line frequency. Motor-generator sets have been widely used to supply 415 hertz power to the mainframe computers which require this frequency, but recently there has been a substantial shift to the use of solid-state inverters.

*e. Uninterruptible power supplies.* If continuous operation is necessary during a line voltage interruption lasting more than a half second or so, then an uninterruptible power supply (UPS) is required. The basic UPS consists of a rectifier/battery charger that takes AC line power of the proper voltage and frequency, a battery bank that takes the place of the rectified DC power source if line power fails, and an inverter that, with suitable filtering, converts the DC power back into a sinusoidal waveform. UPS systems are complex, expensive, somewhat inefficient, have a high output impedance, and frequently require special installation facilities and increased air-conditioning capacity to dissipate the heat. The proper UPS will protect the load equipment from all types of power line disturbances. UPS systems are further described in chapter 22.

*f. Magnetic synthesizer.* The magnetic synthesizer is a static EM three-phase AC power regenerator. The device, powered from the AC utility line, uses no mechanically moving parts in the generation process, and utilizes no semi-conductor elements in the power path. The output waveform of the device is EM generated, and is completely isolated and independent of the input in all parameters except two: the phase rotation and the frequency. The output phase rotation of the device is governed by the direction of the input phase rotation, while the output frequency is precisely keyed to the input line frequency. There is no electrical connection between the input and the output of the device. The improved quality of power results from the synthesis of three-phase 60 hertz voltage waveforms which remain essentially constant in magnitude and shape over a large range of input voltage excursions in both the positive direction (surges) and the negative directions (sags). The device consists solely of saturable iron core reactors and transformers, together with capacitors, and employs the principles of ferro-resonance for its operation.

## 21-5. Motor control centers

Motor control center (MCC) is the term given to a grouping of motor starters within a large enclosure. MCCs are used where several motors are to be operated from a single location. The starters themselves may be magnetic across-the-line starters or other types. A typical use would be in a boiler control room where the various fan, pump, conveyer, and other motors serving the boiler are all controlled from a central location

*a. Construction.* MCCs utilize plug-in type circuit breakers and combination starters in either a front only or a back-to-back freestanding construction, depending on space limitations. Main bus, starters, and breakers are braced to withstand a short circuit current of at least 22 kA, symmetrical. A power panel transformer and feeder breaker, complete with a 120/208 volt power panel and its own main breaker, may be built into the MCC.

*b. Location.* MCCs are strategically located to serve most of the motor loads, lighting transformers, motor operated devices, welding receptacles, and the like. Loads are grouped in such a manner as to result in relatively short feeder runs from the centers, and also to facilitate alternate power sources to vital services.

*c. Connections.* Connections to the MCCs are usually via overhead cable tray, and thus the top horizontal section of the MCC incorporates ample cable training space. Control and power leads terminate in each compartment. MCCs can be designed with all external connections brought by the manufacturer to terminal blocks in the top or bottom horizontal compartments.

## 21-6. Protective devices, fuses, and circuit breakers

Design of power system protection requires the proper application of overload relays, fuses, circuit breakers, protective relays, and other special purpose overcurrent protective devices.

*a. Thermal overload relays.* The most common overcurrent protective device is the thermal overload relay associated with motor starting contactors. Thermal overload relays detect motor overcurrents by converting the current to heat via a resistive element. Thermal overload relays are simple, rugged, inexpensive, and provide very effective motor running overcurrent protection. Also, if the motor and overload elements are located in the same ambient, the thermal overload relay is responsive to changes in ambient temperature. The relay trip current is reduced in a high ambient and increased in a low ambient. The thermal overload relay combines with the short-circuit device to provide total over-current protection (overload and short-circuit) for the motor circuit.

*b. Magnetic current overload relays.* Basically, magnetic current relays are solenoids. These relays operate magnetically in response to an over-current. When the relay operates, a plunger is pulled upward into the coil until it is stopped by an insulated trip pin that operates a set of contacts. Magnetic relays are unaffected by changes in ambient temperature. Magnetic current relays may be used to protect motors with long starting times or unusual duty cycles, but are not an alternative for thermal relays.

*c. Fuses.* A fuse is a non-adjustable, direct acting, single-phase device that responds to both the magnitude and duration of current flowing through it. Fuses may be time delay or non-time delay, current-limiting or non-current-limiting, low-voltage or high-voltage.

*d. Circuit breakers.* A circuit breaker is a device that allows automatic opening of a circuit in response to overcurrent, and also manual opening and closing of a circuit. Low-voltage circuit breakers

are classified as molded-case circuit breakers or power circuit breakers. A molded-case circuit breaker is an integral unit enclosed in an insulated housing. A power circuit breaker is designed for use on circuits rated 1000 Vac and 3000 Vdc and below, excluding molded-case circuit breakers. Molded-case circuit breakers have traditionally been used in panelboards or loadcenters where they are fixed-mounted and accessible. Low-voltage power circuit breakers, on the other hand, are traditionally used in industrial plants and installed in metal-enclosed assemblies. All power circuit breakers are now of the drawout-type construction, mounted in metal clad switch-gear. Low-voltage circuit breaker trip units may be of the electromechanical (thermal-magnetic or mechanical dashpot) or solid-state electronic type. Low-voltage circuit breakers may include a number of trip unit characteristics. These characteristics include long-time pick-up, long-time delay, short-time pick-up, short-time delay, instantaneous pick-up, ground-fault pick-up, and ground-fault delay. The continuous current rating may be fixed or adjustable. Molded-case breakers with solid-state trips and power breakers normally have adjustable long-time and short-time functions. Most molded-case circuit breakers, especially in the smaller sizes, are not provided with long-time adjustments, short-time functions, or ground-fault functions.

(1) The inverse-time (or thermal-magnetic) circuit breaker contains a thermal and a magnetic element in series and is similar in operation to time delay fuses. This circuit breaker will trip thermally in response to overload currents and magnetically in response to short-circuit currents. Magnetic tripping is instantaneous while thermal tripping exhibits an inverse-time characteristic (i.e., the circuit breaker operating characteristics of time and current are inversely proportional). Inverse-time circuit breakers have three basic current ratings: trip rating, frame rating, and interrupting rating. Trip rating is the minimum continuous current magnitude required to trip the circuit breaker thermally. The frame rating identifies a particular group of circuit breakers and corresponds to the largest trip rating within the group. Each group consists of physically interchangeable circuit breakers with different trip ratings. The interrupting rating describes the short-circuit withstand capability of a circuit breaker.

(2) The instantaneous-trip circuit breaker is nothing more than an inverse-time circuit breaker with the thermal element removed and is similar in operation to the non-time delay fuse. This circuit breaker is often referred to by other names, such as, magnetic circuit breaker, magnetic-only circuit breaker, or motor circuit breaker. Instantaneous-trip circuit breakers may be used in motor circuits, but only if adjustable, and if part of a circuit breaker type, combination motor controller with overload relays. Such an arrangement is called a Motor Circuit Protector (MCP) and provides short-circuit protection (circuit breaker magnetic element), overload protection (overload relays), motor control, and disconnecting means all in one assembly. Instantaneous-trip circuit breakers have frame and interrupting ratings but do not have trip ratings. They do have an instantaneous current rating which, for motor circuits, must be adjustable.

*e. Protective relays.* Protective relays are classified according to their function, and there are a wide variety of protective relays available. The overcurrent relay, for example, monitors current and operates when the current magnitude exceeds a preset value. Other types of protective relays provide protection for other abnormal conditions such as overvoltage or ground faults.

## 21-7. Switches

Switches are devices that typically isolate equipment from its main source of power. Large sectionalizing switches are used in substations as described in chapter 20. Control switches are used in lower voltage applications to stop and start motors, turn on lights, and to switch from one source of power to another source of power. Several switches may be required within the control circuit of a major component depending on the complexity. These may be a local switch at the device or area, a main control switch

used for remote operation located at a main facility console, and an auxiliary switch located in another remote location used for emergency or abnormal operation.

### **21-8. Feeder cables**

Feeder cables are generally defined as those cables providing the main source of power to a motor control center, panelboard, or motor. Power cables are generally made up of three components: conductor, insulation and protective covering. The single most important component of a cable is its insulation. The best way to ensure continued reliability of a power cable is through visual inspection and electrical testing of its insulation. They are sized based on the current requirements of the load, the distance from the source of power, and the short circuit withstand capability of the load. The cable sizing may also consider such factors as environmental conditions, location, and raceway fill. Power cables will generally be run in galvanized rigid steel conduit to the termination points.

### **21-9. Controls**

Electric control is a method of using low voltages (typically, 24 Vac) or line voltages (110 Vac) to measure values and effect changes in controlled variables. Electronic controls use solid-state, electronic components used for measurement and amplification of measured signals and the generation of proportional control signals. Common duties of electrical control systems include performing automatic functions, monitoring equipment status, indicating trouble conditions, recording events, generating reports, and indicating maintenance functions.



## CHAPTER 22

# STATIC UNINTERRUPTIBLE POWER SUPPLY

---

### 22-1. General

An uninterruptible power supply (UPS) is designed to provide conditioned power which offsets the effects of adverse normal power. Static UPS systems are more commonly used than rotational type systems and are described in this chapter. Rotary UPS systems are described in chapter 23. A UPS usually consists of a battery to provide continuous source of electrical power; a rectifier/charger to maintain battery charge and to provide input to inverter when utility power is available; an inverter to provide power to load during normal operation; a static switch to transfer load automatically and without disturbance between inverter and utility power; a manual switch to bypass the static switch for maintenance; input and output isolation transformers and filters to provide appropriate isolation and disturbance attenuation; and monitors, sensors, and control circuits.

### 22-2. Battery and battery charger

Battery power is a group of electro-chemical cells interconnected to supply a nominal voltage of direct current (DC) power to a suitable connected electrical load. The number of cells connected in series determines the nominal voltage rating of the battery is the basic factor that determines the discharge capacity rating of the entire battery.

*a. Storage battery.* The storage battery is constructed of a group of identically sized cells connected in series. The number of cells connected in series determines the voltage rating of the battery. The discharge capacity of the battery is basically its ability to supply a given current for a given period of time at a given initial cell temperature while maintaining voltage above a given minimum value. This capacity is stated in amperes normally abbreviated as A, at a given discharge rate. Most stationary battery cells are rated for 8-hour, 3-hour, 1-hour, 15-minute discharge rates to 1.75 volts per cell.

(1) Lead-acid cells are by far the most popular type of secondary cell. Properly sized, installed, and maintained, a stationary battery using lead-acid cells can have a life expectancy of 15 to 20 years in stationary applications, depending upon plate design, relationship between cell capacity and load demand, cycling, care during installation, maintenance, control of discharges and recharges, and site environmental conditions.

(2) Nickel-cadmium batteries are increasingly applied to emergency lighting and other standby service. The active materials are nickel hydroxide in the positive plate and cadmium oxide in the negative. No gases are generated during discharge, and the gases given off during charging are not corrosive. Initial cost of nickel-cadmium batteries is higher than lead-acid on an ampere-hour (Ah) basis. However, at short rates of discharge, from 90 minutes down to 30 minutes the nickel-cadmium battery discharges a greater percentage of its capacity than does the lead-acid. This high discharge feature is even more important at extreme rates of discharge. In some applications the Ah capacity of a lead-acid battery must be twice the Ah capacity of a nickel-cadmium battery to do the same job.

*b. Charger.* The combination of the charger and the battery becomes a system when it is connected to an electrical load. The load is the equipment that draws DC power from the charger and/or battery. The charger-battery load combination is most efficient only when all of the components are properly matched to each other. The charger converts alternating current (AC) power into DC power that is compatible with the battery's voltage and current characteristics. The charger is the converter section of

the UPS which charges the batteries and supplies DC to the inverter.

*c. Floating systems.* When the charger and battery are connected permanently to each other and to the load, and the charger regulates the voltage supplied to the load and the battery, the system is known as a floating battery system. The battery in such systems is mounted normally on a rack or racks housed inside a building or enclosure. The load in this case is the inverter.

*d. Rectifier systems.* The rectifier configuration differs from the float configuration with a rectifier, usually a regulated rectifier, replacing the rectifier/charger. The rectifier is used only to provide power to the inverter and is not used to charge the battery. A blocking diode or thyristor is used to isolate the rectifier from the battery. A separate battery charger is used to maintain the batteries in a fully charged state.

*e. Electrolyte.* The battery electrolyte is a liquid solution of dilute sulfuric acid in which the battery element is immersed for the lifetime of the cell. The ratio of acid weight to water is measured as specific gravity. Pure water has a specific gravity of 1.000. The quantity of electrolyte in a cell is specified in pounds, kilograms, gallons, or liters. Acid electrolyte recommended for most stationary batteries has a nominal specific gravity of 1.215 at 77°F (25°C), when the cell is fully charged. The specific gravity of acid electrolyte gradually drops as the cell is discharged. When the charger resumes operation after a discharge period, the charging process gradually raises the restores the specific gravity of the electrolyte.

*f. Loads.* Specification of the charger and the lead-acid battery depends on the DC load. Each single item of electrical equipment that will be powered by the stationary battery system must be analyzed. Pertinent data required for each item of the load includes: voltage range (window); current or kW draw; duration of operation (time); number of cycles; frequency of use; depth of discharge; and operating temperature range. After this data has been compiled, the battery and charger can be sized and specified.

*g. Environmental conditions.* Environmental conditions and location must also be considered when specifying the battery. Normally storage batteries are sized to perform at 77°F (25°C), but allowance must be made in the calculations for lower temperatures that require more capacity to meet the load criteria. Freezing of the electrolyte results in water crystals forming, but a solid mass is seldom formed. Such crystals damage the plates resulting in reduced life. The charger and UPS performance are adversely affected by altitudes higher than 3,300 feet (approximately 1,000 meters) above sea level or ambient temperatures above 105°F (40°C). Compensations for these factors can be designed into the lead-acid battery system.

*h. Effects of temperature.* Battery capacity is reduced when battery room temperature is normally lower than 77°F (25°C). Battery life expectancy is shortened when the battery room temperature is consistently higher than 85°F (29°C).

*i. Hydrogen gas evolution.* During the charging and discharging process of battery operation, hydrogen gas is formed. Hydrogen gas is very explosive when exposed to open flames, sparks, and cigarettes. The room in which the battery is located should be provided with ventilation, so as to prevent liberated hydrogen gas. Significant amounts of hydrogen are evolved only as the battery approaches full charge. When the cell is fully charged each charging ampere produces 0.016 cubic feet (.0000453 cu m) of hydrogen per hour from each cell. This volume applies at seal level, when the ambient temperature is 77°F (25°C).

*j. Monitoring systems.* Continuous battery monitoring equipment is available which is used in

conjunction with a battery charging system. These systems can monitor float charge rate, voltage levels of individual cells or the complete bank, monitor liquid level and adjust charge cycle and rate of charge.

### 22-3. Inverter

The inverter provides three primary functions in the UPS. Inversion is the changing of the DC power to AC power composed of a sine wave free from harmful harmonic distortion [typically 5% total harmonic distortion (THD) or less]. The inverter also provides regulation of the AC voltage to a tolerance level acceptable to the load, typically +2 percent of the nominal voltage. Finally, current-limiting capability is provided by the inverter as a means of self-protection.

*a. Inversion technologies.* In the world of industrial inverters, two inversion technologies dominate: these are ferroresonant and Pulse Width Modulation (PWM).

(1) PWM inverters synthesize a sinusoidal output waveform from a constant height, variable width high frequency pulse stream. The pulse stream is stripped of its high frequency carrier (20-50 kHz) by a low-pass filter and reduced to a 120 Vac level through a linear power transformer.

(a) The PWM inverter configuration is referred to as an active regulator. Voltage and current feedback loops gather downstream information and deliver it to a microprocessor based control circuit through a series of amplifiers. The bridge circuit in modern PWM technology normally uses insulated gate bipolar transistors (IGBT) for power switching, although, silicon controlled rectifiers (SCR) could be used in high capacity, lower frequency applications. The IGBT bridge generates a positive and negative pulse train at approximately 3 to 6 kHz. The width of the pulses vary from narrow to wide and back to narrow in each half cycle; this pulse width being proportional to the transistor on-time and to the equivalent root mean square (RMS) AC voltage at that moment in time. The control circuit adjusts the transistor conduction time based on the information received from the voltage and current feedback loops to maintain output regulation. The driver network is a parallel power or darlington transistor array. The positive and negative pulse train is then coupled from primary to secondary of a linear output transformer. A small (line-commutated) LC filter with harmonic traps removes the odd order harmonics from the pulse train to create a sine wave.

(b) PWM inverters offer many advantages when used in computer room applications, including high efficiency due to the use of IGBTs and a linear output transformer, small physical size, low cost, and rapid response to transient load changes.

(c) Disadvantages include limited fault and short circuit current availability (due to the output transformer being linear, a downstream short will be felt on the primary and subsequently the IGBTs; the inverter will shut down to protect the transistors), complex circuitry, high parts count, and intolerance to environmental extremes. These items can contribute to lower long-term system reliability, which is a major concern in an industrial facility, based on user philosophy and load architecture. When used in a computer room application, the advantages outweigh the disadvantages because size, cost, and heat dissipation are more critical issues than long term reliability, primarily due to the relatively short useful life of the computer equipment itself.

(2) Ferroresonant inverters do not use linear magnetics. A line frequency square wave developed by the switch bridge is filtered into a sinusoidal wave shape by means of the non-linear actions of a saturated, resonant secondary winding. The peak current demanded by a non-linear load is supplied by the storage energy in the saturated secondary. The load current is not coupled to the switching bridge. The secondary winding also contains harmonic traps tuned to the 3rd and 5th harmonic. Ferroresonant inverters are uniquely compatible with switch-mode power supplies and do not have to be oversized to

provide proper operation.

(a) Ferroresonant inverters are often referred to as a passive regulators. Instead of using active feedback and control, regulation and current limiting are an inherent characteristic of the transformer design. The ferroresonant transformer (sometimes referred to as a regulating or constant voltage transformer) is the heart of the ferro inverter. The integrity of the transformer design and quality control associated with its manufacturer have a direct impact on inverter performance and reliability.

(b) The control and bridge circuits in the ferroresonant inverter consist of a simple square wave generator, traditionally using SCRs, however, some designs now incorporate IGBTs. This square wave is then driven into the primary of the ferroresonant transformer. The ferroresonant transformer is nonlinear, designed to operate in the saturation range of its operating curve. The square wave produced by the bridge saturates the transformer core, therefore, the resultant leakage reactance rounds off the comers during coupling from primary to secondary, creating a “pseudo sine wave.” A tuned LC circuit is then employed to maintain the transformer in a resonant state. Harmonic traps are designed to limit the 3rd, 5th, 7th, etc. odd order harmonics resulting in a distortion free sine wave. A compensation winding is used to tighten the regulation of the transformer.

(c) The primary disadvantage of ferroresonant technology is size and weight, and to some extent cost in the higher power ranges. This is due to the mass of the ferroresonant transformer itself. Historically, criticism has also involved audible noise and efficiency, although the new generation IGBT inverters have bridged that gap tremendously.

(d) Low parts count, hence, inherent high reliability and ease of maintenance make ferroresonant inverters a good choice for industrial applications. In addition, the tuned circuit in the transformer secondary stores energy that can be tapped into for downstream fault clearing (most industrial ferroresonant inverters can deliver 500 percent of their rating for 1 cycle prior to current limit). This energy can also be used to meet the demand for non-linear current, resulting in lower distortion in the output waveform when the loads are predominately non-linear. Since the transformer is a current limiting device, it can continue to run when connected to a bolted short circuit. In summary, the transformer can tolerate a great deal of abuse, both operationally and environmentally without degradation in performance.

*b. Harmonic considerations.* Reflected harmonic current from non-linear loads can cause problems for three-phase inverters. Theoretically, in a balanced three-phase system the neutral current should be zero, however, non-linear loads can induce current in the neutral due to reflected harmonic current (primarily 3<sup>rd</sup>, 5<sup>th</sup>, 7<sup>th</sup>, and 11<sup>th</sup> harmonic) even if the phase current appears balanced. This coupled with the high impedance of the inverter can cause voltage distortion in the output waveform. This effect can be significantly reduced through the use of a Scott-Tee output connection rather than a wye because the triplen harmonics are in phase with one another and effectively cancelled, eliminating the 3<sup>rd</sup> harmonic as a problem.

#### **22-4. Transfer switches**

UPS transfer switches are often the static interrupter type unless the manufacturer’s standard product incorporates the use of circuit breakers necessary for protection and isolation purposes. These breakers or switches are controlled by logic circuits in the UPS inverters or by other circuits included in a common control cabinet or panel. Signals so derived cause closing of the static transfer switch when the monitoring circuits sense the failure of the inverter output or when the UPS module is driven into the “current limit” mode of operation for a preset period of time. Switching speeds as fast as 2 milliseconds are obtainable in standard products of major manufacturers of UPS equipment. UPS systems also usually incorporate a

maintenance bypass switch (or breaker) with a make-before-break feature to allow preventative maintenance to be performed on the UPS.

## **22-5. Instrumentation**

Instrumentation provided with the UPS usually includes a local status panel mounted on the UPS enclosure and a remote status panel which duplicates the LED status indicators and switches on the local status panel.

## **22-6. Operational considerations**

Operational considerations are another key factor in UPS selection. Efficiency and reliability often depend on the type of unit, the load, and the environment. The higher a unit's efficiency, the lower the operating cost.

*a. Noise.* Noise emitted by an UPS can be a factor, depending on the surrounding environment. In most cases, UPSs placed in computer centers, control rooms, or office-type environments need to operate as quietly as possible. Noise levels vary according to the type of system. UPS manufacturers' specifications generally include noise-level data.

*b. Load types.* The type of load being protected is an important consideration, too. Microprocessor-based equipment may require a different type of UPS unit than other loads. For example, switching power supplies, found in most computers, react differently to certain types of UPS systems. Today's UPS units should be capable of supplying non-linear type loads without derating or degradation in total harmonic distortion. Load size determines what size UPS is needed. Systems usually are sized in kilovolt-ampere ratings. Before selecting UPS capacity, a profile of critical electrical loads should be computed, listing the power requirements of each piece of equipment to be protected. Most UPS manufacturers also recommend allowing for a 25 to 30 percent future expansion factor. Systems generally are available in both single-phase and three-phase models to suit the application.

*c. Application.* Consideration should be placed on the application of the UPS. Computer-room UPS components are more densely packaged to create a smaller footprint. Many times, isolation transformers are removed from the front end of a computer type UPS rectifier/battery charger. Although this usually is acceptable in most office/computer-room environments, it can be a problem in an industrial facility due to the presence of large equipment that may cause disturbances during starting.

## CHAPTER 23

### ROTARY UNINTERRUPTIBLE POWER SUPPLY

---

#### 23-1. General rotary uninterruptible power supply

An uninterruptible power supply (UPS) is designed to provide conditioned power which offsets the effects of adverse normal power. Rotational type UPS systems are different from static systems in that they rely on some form of rotational mechanical power to provide the conversion process to electrical power. Typically these systems are generator or flywheel driven. Static UPS are described in chapter 22.

#### 23-2. Rotary UPS design features

A flywheel driven rotary UPS is used for applications requiring ride-through of short duration power system outages, voltage dips, etc. The flywheel driven rotary UPS typically does not include batteries, and support times are usually on the order of a few seconds to a few minutes. The use of a generator driven rotary UPS can provide extended power for an indefinite power outage and also supply air-conditioning and lighting loads. Data processing equipment rooms will typically overheat within a 15- to 30-minute period if the ventilation system is not working, making the generator set a near necessity for outages in excess of this time. Analysis of battery cost will often justify a generator set at lower cost than choosing a long battery support time with an accompanying restriction of eventually implementing an orderly critical load shutdown. A battery support time of as little as a few minutes may be specified with generator set backup; however, longer support times in the range of 15 minutes are more typical.

## CHAPTER 24

# MOTOR GENERATORS

---

### 24-1. General motor generators

Motor generator (MG) sets are utilized to provide electrical power to special electrical loads. Their application is typically as a frequency converter or to isolate electrical systems. The inertia of the motor and generator provide some ride-through capability for momentary voltage interruptions. They also provide excellent long-term ride-through for voltage sags of limited duration or for long-term low voltage conditions.

### 24-2. Motor generator design features

Standard motor generator sets usually provide a ride through of a transient condition for no more than 15 to 30 cycles depending on the load and the mechanical limitations of the motor generator. Usually the limitation is the ability to maintain an output frequency within the tolerance on the load. The Roesel Motor Generator (RMG) is a continuous duty device that provides essential electrical loads with a continuous source of clean, regulated, and isolated 60 cycle power. When a loss or variation of input utility power occurs, the motor-generator continues to supply constant frequency 60 cycle power for a minimum of 15 seconds with full rated load on the unit. At reduced loads it will supply power for up to 45 seconds. When the duration of the power failure is more than 15 seconds or up to 45 seconds at reduced load, the system automatically restarts itself and resumes normal operation when power is restored.

*a. Construction.* The RMG is built as an inverted structure, i.e., the stator is the stationary inner portion with the rotor rotating around it. This provides the best method of obtaining the maximum amount of stored mechanical energy with the least weight in the rotor itself. Exciter coils located on the stator "print" poles on the ferrite lining of the rotor. This is achieved when the exciter heads receive a signal from the generator control and magnetize or re-magnetize the layer of permanent magnet material on the inside rotor surface. The resulting pole pattern is constant in poles per second and thus produces a constant output frequency regardless of rotor speed. The rotor's flywheel effect, extends ride-through time from 15 to 45 seconds depending on load. This allows the RMG to provide rated output voltage and frequency independent of the rotor speed during a loss or variation of utility input power. The RMG provides 15 to 45 seconds of ride-through protection for sensitive loads during voltage disturbances. This is ideal where outages are infrequent and protection against voltage sags is a main concern. The duration of most voltage sags is typically between 10 and 20 cycles (60 cycles = 1 second).

*b. Advantages.* The RMG eliminates the need for costly battery plants [required by conventional uninterruptible power supply (UPS) devices] and associated maintenance, space, ventilation, and environmental concerns, etc. The RMG also eliminates the need for costly power conditioning equipment and establishes a separately derived electrical source for protection of sensitive electronic end-user loads such as computer workstations, file servers, data centers, telecommunication systems, and other critical loads. Finally, the RMG provides total isolation from voltage transients and electrical noise produced by disturbing loads within the facility. It also provides total isolation from interference caused by harmonics (those produced by the protected load and those produced from other loads in the facility).

*c. Disadvantages.* The problems with motor generators are mostly on the output or load side. Very high alternator output impedance can cause substantial voltage dips in response to sudden load changes

such as result from large inrush motor starting current, and response to load changes is sluggish in the range of 0.25 to 0.5 seconds. Also, the drive motor may overheat under long term brownout or low line voltage conditions. Motor generator efficiency is relatively low at about 80 percent, so that electrical energy costs over its lifetime may be substantial. Heat dissipation, weight and bulk, and the potential for annoying audible noise are factors that must be considered in motor generator installation. The use of rotating field exciters has eliminated the need for slip rings, with the consequent brush inspection and replacement, but as with any rotating equipment, bearings must be inspected and periodically replaced.



## CHAPTER 25

# ELECTRICAL CONTROLS

---

### 25-1. General electrical controls

Automation of facilities, along with technically advanced control equipment capabilities, have driven extensive use of sophisticated electrical control systems. Control systems, such as those associated with building automation, process control, and electrical system controls, are being relied on to maintain the integrity of site operations and missions. Common duties of electrical control systems include performing automatic functions; monitoring equipment status; indicating trouble conditions; recording events; generating reports; and indicating maintenance functions.

### 25-2. Major components of an electrical control system

Controls are broadly defined as the methods and means of governing the performance of any electric apparatus, machine, or system by sensing any need for a change and facilitating that change. In performing these duties, control circuits or systems may act to regulate, protect, indicate, open, close, or time an operation. Control devices execute control functions. Some of the more common control devices are switches, push buttons, circuit breakers, contactors, lights, rheostats, timers, alarms, batteries, coils, fuses, relays, solenoids, surge capacitors, lightning arresters, and transformers. Other special electrical equipment may be used also.

*a. Generator controls.* Switchgear and related control panels contain complete controls for all functions of the auxiliary generator equipment. Control for voltage regulation; phase adjustment; current compensation; engine operating parameters as well as engine start, stop, and running speed; battery charging; and brightness or dimming of indicator lights are usually provided.

*b. Indicating devices.* White indicating lamps with colored caps are used to show breaker positions. Green lights indicate open breakers; red lights indicate closed breakers. White lights, when used, are energized from potential transformers to indicate live circuits. Some stations include amber or orange lights to indicate that the circuit has been tripped automatically. Low voltage lamps, connected in series with appropriate resistors, are usually used to reduce lamp size and glare. Red and green lights are usually wired so that they are energized through the trip coil of the breaker. An opening in the trip coil circuit is indicated by a dark unlit lamp. Similar indicating lamps and colored caps are used to indicate normal and abnormal conditions for other control functions of the system.

*c. Device characteristics.* Electromechanical controls are operated by magnets, thermal action, motors, or other mechanical or static actions. Solid-state controls perform similar functions to electromechanical controls, but their characteristics are affected to a much greater degree by ambient temperature changes and excessive electrical circuit parameters.

*d. Power sources.* Control equipment may be powered from storage batteries or from an alternating current (AC) source. Controls will only be as dependable as their operating input. The power supply must be as reliable as possible, so that control and protection of the equipment is not jeopardized.

*e. Electronic loop controls.* Pneumatic and electromagnetic (EM) controls are gradually being

replaced by electronic loop controls, as systems are increasingly being incorporated into energy management control systems (EMCS) or supervisory control and data acquisition systems (SCADA). Sensors are used to provide units of information via conventional (hard) wiring to the field interface devices (FID). A sensor is installed as a component part of the electrical apparatus being controlled and must be maintained by electrical maintenance personnel. Control line components such as FIDs, data transmission links, the central processing unit (CPU), and its subcomponents are not electrical maintenance responsibilities. Communications lines are used, such as telephone pairs; coaxial cable; radio, micro-wave or power line carrier signals; and fiber optics, sometimes as a part of a local area network (LAN).

*f. Relays.* A relay is an electrical device designed to interpret input data in a prescribed manner. When specific input conditions occur, the relay responds to cause contact operation or a similar sudden change in associated electric control circuits. Input data analyzed is usually electrical, but may be mechanical or thermal, or evaluate other conditions or a combination of conditions. Electrical conditions can be overcurrent, overvoltage or undervoltage, a combination of current and voltage, current balance, direction of current flow, frequency, impedance, or other electrical data.

(1) Electric power apparatus relays and relay systems are designed to operate circuit breakers and contactors, usually medium-voltage units. Electric power apparatus relays operate to quickly sense problems and speedily isolate power systems under fault conditions. Such an action limits the extent of electrical equipment damage and provides a means to limit outage periods.

(2) Industrial control relays are designed primarily for industrial control, for switching of communication or other low-level signals, or for any other equipment not controlling electric power apparatus.

(3) Relays can be classified by functions, input operating principals, and performance characteristics. American National Standards Institute/Institute of Electrical and Electronic Engineers (ANSI/IEEE) C37.90, Standard for Relays and Relay Systems Associated with Electric Power Apparatus (1994), covers classifications of relays and also standard service conditions, ratings, tests, and temperature rise.

(4) Relays are classified according to their primary purposes, which are protective, regulating, monitoring, programming, and auxiliary control. Some relays may qualify for more than one classification, depending on their application. Input relays are classified as such because the relay responds to a signal input of either voltage or current. Relays are also classified in accordance to their operating principles or structural features, such as electromechanical or solid-state types.

*g. Relay functions.* Relays are selected to perform certain functions. To standardize on reference use, they are given device function numbers by ANSI/IEEE C37.2, Standard Electrical Power System Device Function Numbers and Contact Designations (1996). (Device function numbers also describe other electrical power apparatus equipment in addition to relays.) Device function numbers readily identify devices in drawings, diagrams, instruction books, publications, and specifications. The use of “52” for circuit breakers, “51” for an AC time overcurrent relay, “65” for a governor, and “86” for a lockout relay provide a simple brief AC method of designation of the device’s operational performance. The standard also covers suffix letters used for main devices (such as “N” for neutral), actuating qualities (such as “A” for amperes), auxiliary devices (such as “CS” for control service), operating device components (such as “TC” for trip coil), and auxiliary contact positions (such as “a” and “b”, “aa” and “bb”).

(1) Instantaneous relays act on an EM attraction operating principle wherein a plunger, solenoid,

hinged armature, or balance beam is pulled into a coil or pole face of an electromagnet. They can be used in both AC and direct current (DC) power systems.

(2) Time-delay relays act on an EM induction operating principle, whereby torque is developed in a movable rotor (disc or cup) which rotates between two faces of an electromagnet. These units can only be used in AC circuits. Time overcurrent and time under/overvoltage relays are generally of the disc design type, while high-speed overcurrent, directional, differential, and distance relays are more often of the cup (cylinder) design type.

(3) Solid-state relays are extremely fast in their operation, as they have no moving parts. Other advantages are lower burden, high seismic-withstand, and reduced panel space. Many are programmable, allowing increased choices of time-current characteristics. There are no formal statistics available, but estimates are that 40 to 50 percent of relays sold in 1992 were solid-state units. Today it is estimated that 85 to 95 percent are the solid-state type. Solid-state relays require no preventive maintenance, but they do require a periodic maintenance check.

(4) Protective relays detect, isolate, and/or indicate abnormal electrical conditions. The operation of circuit breakers or other protective devices is initiated by relays as required. Some of the electrical hazards protected against are short circuit, overcurrent, overvoltage, undervoltage, and phase or frequency irregularities. Relays installed to protect generator stator windings from internal shorts and overheating are sensitive to faults in the generator and do not respond to faults outside the generator. These relays act rapidly to prevent damage to the generator and isolate the generator from the system. Relay action includes de-energizing the generator field winding. Protective relays are provided in systems when reverse power flow occurs. Those relays operate on a succession of power reversals and current impulses to detect loss of synchronism.

## CHAPTER 26

# ELECTRONIC SECURITY

---

### 26-1. Electronic security methodology

Electronic security is an intrusion detection system (IDS) installed to adequately protect valuable assets against adversaries who pose a threat to these assets. Electronic security systems (ESS) are used to alert responsible personnel, such as security guards, to intrusions at protected facilities. In some cases, the system may cause actuation of physical barriers to prohibit intruders access.

*a. Physical barriers.* At most facilities, three barriers are utilized to form lines of defense to physically protect valuable assets. Perimeter barriers are normally found at the edge of the protected property and are considered to be the first line of defense. This may be a fence, wall, or a natural barrier, such as a river, lake, cliff, ravine, or other terrain that is difficult to traverse. The second line of defense is building exterior walls and roof. Interior building rooms, safes, and vaults make up the third line of defense. These physical barriers are mentioned because they establish areas where intrusion detection may be warranted. Depending on the type, configuration, location, and other conditions of the protected area, applicable ESSs are selected from several different types. At property lines and large building walls, intrusion detectors covering large areas are required as opposed to a room within a building or a vault. Also, exterior applications require weatherproof enclosures and are sometimes subjected to a wide temperature range.

*b. Detection systems.* There are many types of electronic security systems in use at military installations. All require frequent tests and checks, in some instances as often as once a day. The emphasis is on operational tests to ensure the continued functionality of the designed system, rather than on routine maintenance of component parts. Before the advent of low-cost computer multiplexed hardware, security systems were simple hardwired alarm systems, providing a minimum level of intrusion detection. Today, the system may be a fully redundant computer-based system interfaced with a redundant looped time-division-multiplexed communication network for gathering alarm data from sensors and for sending commands to release locked doors under the card-access control subsystem. The remote multiplexer may be microprocessor-based units, capable of data collection, communication with the host computer, and performing limited-access control functions. The security system provides location information as well as delay time for the guards. By successive detections, the security force can track the intruder and relay location information via portable radio communications equipment to the responding guards. In turn, the guards can constantly inform the security force on the progress of their work or the need for additional assistance. The cameras, using various means of target intensification, can “see” better than the human eye. Guard patrols are also used to detect unusual activity. Perimeter detection is accomplished by the application of electronic detection systems.

### 26-2. Types of electronic security

Electronic security systems can be placed into two categories – perimeter detection and interior detection.

*a. Perimeter detection.* Perimeter detection is that used to prevent entry into a restricted area and the devices are usually located to protect the exterior premises.

(1) Microwave detection links are devices mounted on posts inside the fence. Transmitters radiate amplitude modulated X-band energy, and receivers detect and process the received energy. Thus, an invisible energy envelope is produced that will detect an intruder.

(2) Infrared detection links are devices that are post-like and mounted inside the fence. Transmitters radiate multiple beams of modulated infrared energy, and the receivers detect and process the energy. Penetration of the invisible infrared shield will alarm the system.

(3) E-field links are transmitter wires and receiver wires are strung horizontally from mounting posts located inside the fence or mounted on the fence. A radio-frequency energy field is generated around the wires. The intrusion of a person into the invisible field will “short” energy, creating an alarm.

(4) Buried sensor links are devices sensing seismic pressure, [or electromagnetic (EM)disturbances for a combination of these] are buried inside the fence, and alarm upon the intrusion of someone into the field of detection.

(5) Other systems are available that can be used in combination with the previously mentioned systems. The probability of detection by these outdoor devices depends on their application. Perimeter detection equipment must be applied with consideration of the environmental limitations of the device’s technology.

*b. Interior detection.* If the intruder penetrates the perimeter detection, the protected area has been breached. The interior detection then must be in place to prevent further entry into controlled or protected buildings.

(1) Visual or closed-circuit television surveillance may detect the intruder.

(2) Entry into a building is provided by the application of a balanced magnetic switch on doors and openings. This device uses an internal bias magnet to balance a delicate reed switch in the field of the external magnet attached to the door. Should the door be opened, even a fraction of an inch, or should another magnet be introduced in an attempt to defeat it, the switch will change state and alarm.

(3) Other devices for detection of an intruder may be applied inside the building, including microwave and infrared motion detection, photoelectric or laser beams, seismic, sound detection, passive infrared, and other devices.

## CHAPTER 27

# HIGH-ALTITUDE ELECTROMAGNETIC PULSE (HEMP) PROTECTION SYSTEMS

---

### 27-1. General HEMP protection systems

Command, Control, Communications, Computer, Intelligence, Surveillance, and Reconnaissance (C4ISR) facilities contain miniature solid-state electronics. These devices will fail when subjected to voltages that exceed the dielectric strength of the component or when the device melts as a result of heating from currents induced by a radio frequency (RF) pulse. Most people are familiar with the effects of lightning upon solid-state equipment. Other sources are High Power Microwave (HPM), Ultra Wide Band (UWB) waveforms, and High-Altitude Electromagnetic (EM) Pulse (HEMP). This chapter concerns itself with HEMP that is produced by a nuclear weapon detonated at a high altitude.

*a. Reliance on electronic technology.* Military facilities are becoming increasingly reliant on automated systems that take advantage of modern electrical and electronic technology. Facilities are equipped with state-of-the-art computerized systems for expeditious, reliable, and cost-effective operations. However, the EM properties of many electronic components can make entire systems susceptible to upset or permanent damage due to the environmental effects of HEMP. Systems are also susceptible to the compromise of security information by the unintentional intelligence-bearing emanations of EM signals. Thus, with the benefits of automation has come an increased vulnerability.

*b. Early planning.* Techniques to protect a facility are usually selected during the early design phase. If it is anticipated that a facility may someday acquire equipment that must be protected, early planning can avoid costly retrofitting later. The decision to harden will be based on the interaction of mission criticality, EM environment, security requirements, and costs.

*c. Far-reaching effects.* HEMP is dangerous because this event has far-reaching effects at distances where other nuclear environments are either nonexistent or inconsequential and because of its high level of broad spectral energy. However, the spectrum included under HEMP does not cover all EM environments. For example, the characteristic pulse rise time and possible conducted current waveforms for lightning differ from those for HEMP; thus, hardening against HEMP does not necessarily protect against lightning.

### 27-2. HEMP procedures

HEMP is defined as EM pulses produced by nuclear explosions at high altitudes. HEMP hardened facilities are intended to provide vital communications at a time when unhardened facilities are likely to fail. If initial HEMP hardness for a facility degrades during day-to-day operations, then unexpected system failures could seriously compromise communication assets as a result of a nuclear event. Because degradation in HEMP hardness has little effect on the normal facility operations, specific surveillance, maintenance, and operational procedures must be employed to detect and repair degradation in facility hardness.

### 27-3. Modes of HEMP entry

Modes of HEMP entry include diffusion, leakage through apertures, antennas, and conductive penetrations.

*a. Diffusion through the shield.* HEMP fields diffuse through imperfectly conducting walls of shielded enclosures. The diffusion is greatest for magnetic fields and is a low-pass filtering event, as shown by the magnetic shielding effectiveness curve. Thus, the field that reaches the inner region of a shielded enclosure is basically a low-frequency magnetic field. This effect is greatest in an enclosure with solid metal walls. It is also seen somewhat in enclosures with metal rebar or wire mesh reinforcement. The reduced shielding effectiveness at high frequencies for rebar and wire mesh structures allows a significant fraction of the incident HEMP environment to penetrate to electronics inside the enclosure.

*b. Leakage through apertures.* Openings and other shielding compromises include doors, windows, holes for adjustments and display units, seams, improperly terminated cable shields, and poorly grounded cables. Unless properly treated, each opening is a leak through which the HEMP field can couple directly into the shielded enclosure. Leakage through an aperture depends on its size, the type of structure housing it, and its location. The aperture responds to both total magnetic and electric fields at the site of the leak.

*c. Intentional and inadvertent antennas.* Intentional antennas are designed to collect EM energy over specified frequency bands. However, there will also be an out-of-band response to HEMP. Because the incident HEMP field has a broad frequency spectrum and high field strength, the antenna response must be considered both in and out of band. Analytical models are available for determining the different antennas' responses to HEMP. These models, along with the incident field, yield the HEMP energy that appears at the connecting cable. This energy later reaches the electronic systems inside the enclosure at the other end of the connecting cable. Inadvertent antennas are electrically conducting, penetrating external structures, cables, and pipes that collect HEMP energy and allow its entry into the enclosure. As a rule, the larger the inadvertent antenna, the more efficient energy collector it is in producing large, transient levels in the enclosure. The coupling for inadvertent antennas can be analyzed using transmission line and simple antenna models.

*d. Conductive penetrations.* Many factors affect the coupling of EM energy to penetrating conductors. The HEMP waveform characteristics, such as magnitude, rate of rise, duration, and frequency, are each important. Further, the observer's position with respect to the burst is a factor. Because the interaction between fields and conductors is a vector process, the direction of arrival and polarization is also important. Conductor characteristics also affect HEMP coupling. These include conductor geometry (length, path, terminations, distance above or below the earth's surface), physical and electrical properties that determine series impedance per unit length (including diameter, resistivity, and configuration), and the presence and effectiveness of shielding. For overhead or buried conductors, the electrical properties of soil affect coupling. Many elements of a facility can act as efficient collectors and provide propagation paths for HEMP energy. HEMP can couple to structures such as power and telephone lines, antenna towers, buried conduits, and the facility grounding system. Actual antennas, nonelectrical penetrators such as waterpipes, and any other conductive penetration can couple HEMP energy into a structure. In addition, if the structure is not shielded or is not shielded well enough, HEMP can couple to the cables between equipment inside.

### 27-4. Equipment susceptibility

System damage or upset from HEMP is caused by currents and voltages induced in conductors exposed to a free-field or partly attenuated EM pulse coupled to circuits. The narrow resonance results from

circuits of high Q (quality factor) which have low resistive dissipation of energy. External conductors, structures, and internal conductors act as unintentional receiving antennas and “coupling” paths. They can deliver the resulting HEMP-induced currents and voltages to sensitive components of electronic equipment. The HEMP-induced currents on exterior long-line penetrators, such as power and telephone lines, can have amplitudes as high as thousands of amperes. Currents induced on internal cable runs can be as high as hundreds of amperes for most structures and even higher in facilities with lower systems engineering (SE). It is important to note that exterior voltage transients can be in the megavolt range, and it would be normal to expect an order of thousands of volts from internal coupling.

*a. Effects of transients.* Transients of these magnitudes can be delivered to electronic circuits, such as integrated semiconductor circuits, which can be damaged by only a few tens of volts, a few amperes, or less. These circuits also operate at relatively low levels (e.g., 5 volts and tens of milliamperes) and can be upset by HEMP currents of similar values. If the large exterior coupled transients were allowed to enter a structure that had no HEMP protection treatment, even relatively “hard” devices, such as relay coils, could suffer damage.

*b. Equipment responses.* HEMP produces two distinct responses by equipment and system components: upset and damage. Upset is a non-permanent change in system operation that is self-correcting or reversible by automatic or manual means. Damage is an unacceptable permanent change in one or more system parts.

*c. Damage thresholds.* The passive elements most susceptible to damage from HEMP-induced currents are those with very low voltage or power ratings and precision components for which a small change is significant. Resistor failures due to high-level pulsed currents are caused by energy-induced thermal overstress and voltage breakdown. Resistor failure threshold can be calculated from the resistor’s parameters and the empirical relation. Exposure of capacitors to transient currents sets up a voltage across the capacitor that increases with time. For non-electrolytic capacitors, this voltage keeps rising until the capacitor’s dielectric breakdown level is reached. That point is typically 10 times the direct current (DC) voltage rating. For electrolytic capacitors, the voltage relationship holds until the zener level of the dielectric is reached. After that, damage can occur. The damage threshold for electrolytic capacitors in the positive direction is 3 to 10 times their DC voltage rating. For the negative direction it is one-half their positive failure voltage. Transformer and coil damage due to HEMP-induced currents results from electric breakdown of the insulation. The pulse breakdown voltage is typically 5500 volts for power supply transformers and 2750 volts for small signal transformers.

## **27-5. HEMP protection systems**

Traditional methods of electromagnetic interference (EMI) isolation often use metal enclosures to prevent unwanted radiation from entering the circuit. These shields provide effective protection along with good grounding techniques, therefore, HEMP protection systems are static as they do not have any moving parts. An exception to this is finger stock material that springs into place when doors or windows are closed. Only during an electromagnetic pulse (EMP) environment does the system function to shield the hardened facility. HEMP protection system components should not be disturbed or disconnected.

*a. Electronic surge arresters.* An area in which care must be taken to ensure compatibility in EM integration is surge protection. Some surge arresters used for lightning do not clamp fast enough to protect against HEMP. Some used for HEMP may not have great enough current carrying capacity for lightning protection in all situations.



*b. Shielding.* For HEMP-hardened facilities, some kind of EM shielding is essential. Shielding involves the use of a barrier or series of barriers to reduce the magnitude of the EM energy incident upon the electronic or electrical system to be protected. Shielding philosophy can be developed around different approaches.

(1) Global shielding (or hardening) is a protection concept that uses an overall shield to encompass the entire facility. In this approach, all conducting penetrations and all apertures are protected at the shield. The intent is to keep all HEMP fields and HEMP-induced transients outside the protected volume. The global shield could be placed on the entire outer walls, ceiling, and floor (surface) of the facility, or it could be reduced to a smaller volume that contains all sensitive equipment to be protected. The most common shield material for global shielding of ground-based facilities is sheet steel with welded seams, although other designs can provide adequate global HEMP shielding.

(2) Tailored shielding is a protection concept in which shielding is designed and constructed according to specific protection requirements for the equipment involved. After defining the system to be protected, its possible operating configurations, the expected HEMP environment, coupling paths, equipment sensitivities, and subsystem/system criticalities, the required protection levels for various subsystems or groups of subsystems can be defined. Tradeoff studies may be performed for comparing various shielding arrangements to verify that they meet safety margins in protection, cost-effectiveness, maintainability, survivability, flexibility, and other requirements. The objective is to optimize protection for the specific mission-critical system. Tailored shielding options may include global shielding, zonal shielding, shielding of cabinets or components, or combinations thereof. In a typical tailored protection design, discrete protection will be provided to eliminate specific, localized deficiencies.

(3) Zonal or topological shielding is a concept in which a facility is divided into zones, with shielding barriers located topologically in a shield within a shield configuration. The outer zone is designated zone 0; zone 1 is inside shield 1 but outside shield 2. Zones and shields are assigned increasingly larger numbers as they progress toward the more deeply nested areas.

(4) The term "system configuration" identifies which way the cables, wires, equipment, and subsystems are laid out in relationship to each other, as well as the relationship of these items to the topological boundaries. In some instances, the cables, connectors, and equipment casings are actually part of the topological protection. System configuration as defined does not directly attenuate the environment, but it is an important element in the topological protection concept. The system configuration influences protection design requirements since some configurations are easier to protect than others (e.g., co-location of all mission-critical equipment). Thus, the system configuration should be coordinated with the protection design and the protection topology will be optimal for a specific configuration. During the facility life cycle, the protection design may be required to accommodate some changes in configuration. To ensure that the configuration's design modifications do not compromise or defeat the protection, careful configuration management is necessary. The topology should be designed to tolerate configuration changes that are totally within a boundary. The boundary can never be violated (for example, opened)--only extended. All modifications must be subjected to review by HEMP experts to ensure continual compliance with the HEMP hardening requirements.

(5) Conductive or metallic cable shielding or conduit is used in the zonal/topological protection concept to extend the boundary formed by equipment enclosures and thus provide a way to interconnect elements while maintaining boundary continuity. Cable shielding is also used to protect a wire or wires as they travel from one boundary to another. This would be the case with a shielded RF signal traveling from its entrance into a building to the RF receiver. From a HEMP standpoint, the shielding attenuates coupling of radiated energy within the first boundary as the signal travels to the receiver. Of course the shield is

somewhat reciprocal in that it also prevents signals from radiating out of the cable. The main feature of cable shielding is continuity of the boundary provided by the cable shield/connector combination that may require special joints.

(a) Another way to maintain this continuity and provide cable shielding is by using steel conduit to house all wires and cables. The steel conduit will provide substantially higher shielding levels than the cable shields.

(b) Both cable shields and conduit connected to a shielded zone must have equal or greater shielding effectiveness than the shield.

c. *Grounding.* Some form of grounding is required in any electrical or electronic system for protecting personnel from electrical shock, controlling interference, proper shunting of transient currents around sensitive electronics, and other reasons. (Grounding does not directly provide protection against HEMP, but must be done properly to prevent creation of more serious HEMP vulnerabilities.) Ideally, grounding would keep all system components at a common potential. In practice, because of possible inductive loops, capacitive coupling, line and bonding impedances, antenna ringing effects, and other phenomena, large potentials may exist on grounding circuits. The choice of grounding concept is therefore important in the HEMP protection philosophy.

d. *Shield penetration protection.* All shielded zones will require penetrations to allow entry of equipment, personnel, electric power, communications, control signals, ventilation, water, fuel, and various fluids. Without protection, these penetrations compromise the shield.

(1) Large access doors are often necessary to provide an entry for equipment, supplies, or vehicles into HEMP hardened facilities. In facilities that require blast overpressure protection, large blast doors are used. These doors generally use one or more thick steel plates to provide protection. The door's inherent shielding ability is thus high, but its large size presents a difficult gasketing problem. If blast protection is not required, it is still necessary to design the door with a high degree of structural strength. This step is to ensure that the door can provide the necessary gasket compression force and that proper mechanical alignment of closure contact surfaces is maintained.

(2) Two concepts are commonly used for personnel entrances: conventional HEMP/radio frequency interference (RFI) shielded doors and personnel tunnels that act as waveguides below cutoff. The shielded doors generally use metal fingerstock or EMI/RFI gaskets to provide an EM seal around the door jamb periphery. Currently available gasket and fingerstock doors require regularly scheduled maintenance and/or replacement to maintain required shielding levels. The gaskets are relatively easily damaged and also require replacement. Air-expandable doors may also be used, although they typically have more maintenance problems. These doors generally use a movable subassembly of two shielding plates on a framework that is moved on rollers in and out of a steel-framed opening. When closed, air expansion tubes cause the two shielding plates to make uniform surface contact with the frame inner surfaces.

e. *Electrical penetrations.* A common feature for electrical penetrations in a global protection approach is a cable entry vault to prevent large currents on external conductors from being conducted into the facility. Ideally, all penetrations should enter a single vault. In some cases, however, it may be necessary to separate the vault into two compartments or to use two vaults for penetrations by different types of lines: power, signal and control, and antenna. The vault must be connected directly to the external facility ground system. Conductive penetrations, such as a conduit, waveguide, or shielded cable,

must have a circumferential weld or other means of providing good electrical connection at the intersection with the entry vault. The cable entry vault serves three purposes:

(1) To insure that penetrating conductors do not cause conducted HEMP energy to enter the protected topology.

(2) To contain and divert penetrator-conducted HEMP energy to the boundary exterior.

(3) To contain or divert radiant EM energy resulting from the activation of transient suppression devices subjected to a conducted pulse.

*f. Transient suppression devices and filters.* Transient suppression devices fill a critical gap in the concept of topological protection. The necessity of supplying power to a facility and of communicating over cables or antennas are two major factors contributing to their use. Power lines entering a facility are typically connected to an unshielded power grid so that large, conducted currents must be bled off to prevent their entry into a facility. These currents are diverted to the exterior boundary of the topology. This boundary can be an overall external shield or an enclosed entrance vault. Antennas, such as for high-frequency (HF) communications, are designed to gather EM signals (at wavelengths in the HEMP frequency spectrum) and to apply these signals to the center conductor of a shielded cable. The HEMP transients associated with an HF antenna can be, by far, the largest single signal entering a facility. Transient suppressors often are used in conjunction with filters. Filters are frequency-selective whereas surge suppressors are amplitude-selective. Filters often are used to attenuate transients associated with the non-linear operation of surge arresters. They also are used for selectively passing (or stopping) frequency bands as in the case of antenna cable penetrations. Transient suppressors are an integral part of the EM topology, demanding specific installation techniques as will be seen later. A spark gap is a surge suppressor that provides a conducting path to ground when the voltage across the device exceeds the gap breakdown level. Spark gaps with a high current capacity do not operate quickly enough to block all HEMP energy transients entering the vault. For this reason, it may be necessary to use other protection devices in conjunction with the spark gap.

*g. Electromagnetic isolation.* The EM isolation concept involves the use of elements either immune to interaction with EM radiation or which provide a current path interruption. Optical fibers are examples of elements immune to EM radiation that can be used to reduce the number of conductive penetrations. For practical purposes, optical fibers can be used for long communications links without signal interference from HEMP. Further, they can be used to enter shielded zones through waveguide below cutoff penetrations without compromising the EM shielding effectiveness.

*h. Dielectric isolation.* Other isolation techniques include using dielectric isolators for shield penetration when external metallic EM energy collectors are involved. Examples are control rods or cables (normally metallic), piping systems for fluids, and metallic duct systems for air. Dielectric sections are installed at or near the shield to prevent the energy induced on the external metallic part from being conducted through the shield. Dielectric control rods can enter through a shield in the same way as optical fibers, that is, through a waveguide-below-cutoff section.

*i. Isolation switching.* Although not recommended now, isolation switching has been provided at facilities so they can use commercial electric power during routine operation, but can switch to internal generators or power systems in the event of an emergency such as nuclear attack. Since the commercial power wiring is a source of significant HEMP energy injection through a shield, switching to internally generated power is an obvious advantage when advance warning of impending nuclear attack is received and throughout the entire nuclear attack cycle. This concept applies to communications lines and control

lines as well as power lines. Switching used in past facility designs has been called “alert attack” switching. Such switching must provide adequate switch contact separation to prevent arcing, and must be designed to reduce coupling interactions between wiring and switch contacts to acceptable levels.

## CHAPTER 28

### TEMPEST PROTECTION SYSTEMS

---

#### 28-1. General TEMPEST protection systems

This chapter addresses systems constructed to prevent adversaries acquiring compromising information from facilities containing classified information. Facilities house equipment that are sources of electromagnetic (EM) waves and stray currents/voltages with characteristics which are related to the information content of the signals being processed. If these unintentional emissions are intercepted and studied, the analyst can reconstruct the original data and can obtain access to classified national security information. TEMPEST (military code-name) protection systems will, preclude the presence of analyzable signals in uncontrolled areas by controlling EM energy and, thus, provide communication security.

*a. Scope.* TEMPEST is a U. S. Department of Defense program to develop methods of preventing the compromise of government and military information. This is accomplished by reducing or eliminating unintended electric or EM radiation emanations from electronic equipment. The present approach focuses on "threat-based systems approach" in an effort to reduce the high cost of TEMPEST efforts. Emission Security (EMSEC) is another term that has found favor and covers all emanations with potential to compromise national security information and the measures employed to prevent unauthorized disclosure.

*b. Objectives.* The TEMPEST problem is nearly the inverse of the High-Altitude Electromagnetic Pulse (HEMP) event. TEMPEST is the unclassified name for the studies and investigation of compromising emanations. Equipment within the facility can be the source of EM waves and stray currents/voltages with characteristics that are related to the information content of signals being processed. Thus, HEMP and TEMPEST protective measures must each control EM energy, the former protecting system equipment from externally generated signals and the latter containing emissions from internal sources. The functional similarities imply that a common treatment can be employed for the two purposes.

#### 28-2. Sources

Compromising emanations may be generated by any electrical information processing equipment. Some of them are microchips, computers, monitors, printers, and electronic typewriters. These emanations can be propagated through space, over telephone lines, power lines, water pipes, grounding wires, ducts, drains, and conduit.

#### 28-3. Acquisition

Using specialized antennae, low noise pre-amps, filters, and top end receivers with computer interfaces it is possible to access sensitive information for immediate interpretation or analysis later. Unclassified estimates place interception ranges at 1 km.

#### 28-4. Protection

To mitigate or eliminate compromises in security, several techniques are used.

*a. Evaluation.* TEMPEST measures shall be weighted based on the sensitivity of information, the amount of classified information, and the probability of facility becoming an intercept target.

*b. Personnel control.* Equipment must be kept physically secure by providing physical controls to prevent, delay, and detect unauthorized access to the central computer facility, internal controlled areas, peripheral devices, remote terminals, and storage media. In many cases, the physical controls consist of determining what personnel may enter or leave a given site, and what equipment must be kept under controlled circumstances. The current emphasis in military systems is on dedicated computer systems.

*c. Compartmentalism.* TEMPEST protection requires that information under one classification and compartment be isolated from other classifications and compartments. The separation requirements are based on "Equipment Radiation Transmission Zone (ERTZ)." Emanations are allowed within the ERTZ as determined by engineering estimates, ambient noise levels (masking), facility construction, and distance from source.

*d. Physical controls.* It is a requirement that electronic equipment used for classified processing be shielded or designed to reduce or eliminate transient emanations.

(1) One method is to shield the area in which the information is processed so as to contain EM emanations or to specify control of certain distances or zones beyond which the emanations cannot be detected. In many cases, facilities are required to be kept within complete metal enclosures to prevent EM leakages, and vacuum seals to prevent sonic leakages. High noise environments are sometimes artificially generated to make the detection of signals very difficult. Shielding can also be applied to equipment cabinets and chassis via radio frequency interference (RFI) seals and honeycomb filter doors.

(2) Unless the wiring (telephone lines, electrical wiring, network cables, etc.), is shielded the other shielding methods discussed will not stop emanations from leaking to the outside world. All conductors must be isolated at the point of egression, including drains, pipes, ducts, cable trays, and conduits.

(3) Separating classified and unclassified equipment transmission paths can eliminate this form of cross cable leakage. Power lines for classified equipment must be isolated.

(4) EM signal strength can be minimized by filtering signals on the electrical leads. This is accomplished by using ferrites and optically coupled filters. Power lines for classified equipment must be filtered.

(5) Station earth ground point must not be shared by any other facility. Classified equipment must be properly grounded.

## CHAPTER 29

# GROUNDING

---

### 29-1. General grounding systems

Reasons for grounding include electrical safety, effective lightning protection, diminishing electromagnetic coupling (EMC), and protection against electromagnetic pulses (EMP). Grounding practices and stipulations are well defined in documents published by the Institute of Electrical and Electronics Engineers, Inc. (IEEE), American National Standards Institute (ANSI), National Fire Protection Association (NFPA), and U.S. Department of Defense (DoD). Grounding is provided to limit potential (voltage) differences to values that will not cause undue hazards to personnel and equipment. A ground system that provides adequate current-carrying capacity and a low resistance path to an earthing connection will dissipate, isolate, or disconnect overpotential areas resulting from fault overcurrents or surge overvoltages. A ground path can consist of single or multiple conductors whose connection provides adequate thermal and conductance capacities. The earthing connection is generally a metallic electrode such as a rod, a water pipe, a counterpoise, or a ground grid system installed below grade.

### 29-2. Types of grounding

Electrical power distribution systems can be either ungrounded, solidly grounded, or resistance grounded.

*a. Ungrounded system.* An ungrounded system is one in which there is no intentional connection between the neutral or any phase and ground. Ungrounded system implies that the system is capacitively coupled to ground. The neutral potential of an ungrounded system under reasonably balanced load conditions will be close to ground potential because of the capacitance between each phase conductor and ground. When a line-to-ground fault occurs on an ungrounded system, the total ground fault current is relatively small, but the voltages to ground potential on the unfaulted phases will be high. If the fault is sustained, the normal line-to-neutral voltage on the unfaulted phases is increased to the system line-to-line voltage (i.e. square root of three times the normal line-to-neutral value). This, over a period of time, breaks down the line-to-neutral insulation and hence results in insulation failure. Ungrounded system operation is not recommended because of the high probability of failures due to transient overvoltages caused by restriking ground faults. The remaining various grounding methods can be applied on system grounding protection depending on technical and economic factors. The one advantage of an ungrounded system that needs to be mentioned is that it generally can continue to operate under a single line-to-ground fault without an interruption of power to the loads.

*b. Solidly grounded system.* A solidly grounded system is one in which the neutral (or occasionally one phase) is connected to ground without an intentional intervening impedance. On a solidly grounded system, in contrast to an ungrounded system, a ground fault on one phase will result in a large magnitude of ground current to flow, but there will be no increase in voltage on the unfaulted phase. Solid grounding is commonly used in low voltage distribution systems. Solid grounding has the lowest initial cost of all grounding methods. It is usually recommended for overhead distribution systems supplying transformers protected by primary fuses. However, it is not the preferred scheme for most industrial and commercial systems, again because of the severe damage potential of high magnitude ground fault currents.

*c. Resistance grounded system.* Limiting the available ground fault current by resistance grounding is an excellent way to reduce damage to equipment during ground fault conditions, and to eliminate personal

hazards and electrical fire dangers. It also limits transient overvoltages during ground fault conditions. The resistor can limit the ground fault current to a desired level based on relaying needs. At the occurrence of a line-to-ground fault on a resistance grounded system, a voltage appears across the resistor that nearly equals the normal line-to-neutral voltage of the system. The resistor current is essentially equal to the current in the fault. Therefore, the current is practically equal to the line-to-neutral voltage divided by the number of ohms of resistance used. The grounding resistances are rated in terms of current and its duration for different voltage classes.

(1) Low resistance grounding refers to a system in which the neutral is grounded through a small resistance that limits ground fault current magnitudes. The size of the grounding resistor is selected to detect and clear the faulted circuit. Low resistance grounding is not recommended on low voltage systems. This is primarily because the limited available ground fault current is insufficient to positively operate series trip units and fuses. These trip units and fuses would be dependent upon both phase-to-phase and phase-to-ground fault protection on some or all of the distribution circuits. Low resistance grounding normally limits the ground fault currents to approximately 100-600A. The amount of current necessary for selective relaying determines the value of resistance to be used.

(2) High resistance grounding refers to a system in which the neutral is grounded through a predominantly resistive impedance whose resistance is selected to allow a ground fault current through the resistor equal to or slightly more than the capacitive charging current of the system. Because grounding through a high resistance entails having a physically large resistance that is both bulky and costly, high resistance grounding is not practical and is not recommended. However, high resistance grounding through a grounding transformer is cost effective and accomplishes the same objective. High resistance grounding accomplishes the advantage of ungrounded and solidly grounded systems and eliminates the disadvantages. It limits transient overvoltages resulting from a single phase-to-ground fault by limiting ground fault current to approximately 8A. This amount of ground fault current is not enough to activate series overcurrent protective devices, hence no loss of power to downstream loads will occur during ground fault conditions. Special relaying must be used on high resistance grounded systems in order to sense that a ground fault has occurred. The fault should then be located and removed as soon as possible so that if another ground fault occurs on either of the two unfaulted phases, high magnitude ground fault currents and resulting equipment damage will not occur. High resistance grounding is normally applied in situations where it is essential to prevent unplanned system power outages, or previously the system has been operated ungrounded and no ground relaying has been installed. Once the ground point has been established through the resistor, it is easier to apply protective relays. The user may decide to add a ground overcurrent relay. The relay may be either current actuated using a current transformer or voltage actuated using a potential transformer. Depending on the priority of need, high resistance grounding can be designed to alarm only or provide direct tripping of generators off line in order to prevent fault escalation prior to fault locating and removal. High resistance grounding (arranged to alarm only) has proven to be a viable grounding mode for 600V systems with an inherent total system charging current to ground of about 5.5A or less, resulting in a ground fault current of about 8A or less. This, however, should not be construed to mean that ground faults of a magnitude below this level will always allow the successful location and isolation before escalation occurs. Here, the quality and the responsiveness of the plant operators to locate and isolate a ground fault is of vital importance. To avoid high transient overvoltages, suppress harmonics and allow adequate relaying, the grounding transformer and resistor combination is selected to allow current to flow that equals or is greater than the capacitive charging current.



### 29-3. Grounding systems

Basically six types of grounding systems are used. They are static grounds, equipment grounds, system grounds, lightning grounds, electronic (including computer) grounds, and maintenance safety grounds. All of these systems are installed similarly. However, their purposes are quite different. Some of the systems carry little or no current. Others carry small to moderate currents at 50 or 60 Hz. Still others must be able to carry currents over a very broad range of frequencies in order to be considered effective.

*a. Static grounds.* A static ground is a connection made between a piece of equipment and the earth for the purpose of draining off static electricity charges before a spark-over potential is reached. The ground is applied for more than just the comfort of the equipment operator. The possibility of an explosion ignited by an electrical spark must be considered. Dry materials handling equipment, flammable liquids pumps and delivery equipment, plastic piping systems, and explosive storage areas all need static ground protection systems installed and functioning properly. Static ground systems are generally not called upon to conduct much current at any given frequency. Smaller gauge, bare conductors, or brushes with metallic or conductive bristles make up most parts of the static ground system.

*b. Equipment grounds.* An equipment ground pertains to the interconnection and connection to earth of all normally non-current carrying metal parts. This is done so the metal parts with which a person might come into contact are always at or near zero volts with respect to ground thereby protecting personnel from electric shock hazards. Equipment grounding consists of grounding all non-current carrying metal frames, supports, and enclosures of equipment. All these metallic parts must be interconnected and grounded by a conductor in such a way as to ensure a path of lowest impedance for the flow of ground fault current from any line to ground fault point to the terminal at the system's source. An equipment grounding conductor normally carries no current unless there is an insulation failure. In this case the fault current will flow back to the system source through the equipment grounding conductors to protect personnel from electrical shock. The equipment grounding conductor must never be connected to any other hot lines. Equipment grounding systems must be capable of carrying the maximum ground fault current expected without overheating or posing an explosion hazard. Equipment grounds may be called upon to conduct hundreds to thousands of amperes at the line frequency during abnormal conditions. The system must be sized and designed to keep the equipment surface voltages, developed during such abnormal conditions, very low. An example of this system is the bare copper wire (green conductor) connected to the frames of electric motors, breaker panels, outlet boxes, etc. Electrical supporting structures such as metal conduit, metal cable trays, or metal enclosures should be electrically continuous and bonded to the protective grounding scheme. Continuous grounding conductors such as a metallic raceway or conduit or designated ground wires should always be installed from the ground grid system to downstream distribution switchboards to ensure adequate grounding throughout the electrical distribution system. Part of the equipment ground is also formed by the switchgear ground bus.

*c. System grounds.* A system ground refers to the condition of having one wire or point of an electrical circuit connected to earth. This connection point is usually made at the electrical neutral although not always. The purpose of a system ground is to protect the equipment. This ensures longer insulation life of motors, transformers, and other system components. A system ground also provides a low impedance path for fault currents improving ground fault relaying selectivity. In a properly grounded system the secondary neutral of a power transformer supplying a building or facility is connected to a transformer grounding electrode. The transformer neutral is a part of the service entrance point that bonds to the grounding electrode system of the building. According to the National Electrical Code (NEC), NFPA 70, articles 250-81 and 250-83, metal underground water pipes, metal building frames, encased electrodes, rods, and plates are among the items that can make up the grounding electrode system of a building. The NEC article 250-83 requires that the size of the grounding electrode iron or steel rod

must be at least 5/8 inches in diameter and driven eight feet deep. The resistance of the electrode to ground cannot exceed 25 ohms (NEC 250-84). Otherwise a second electrode should be added, and the distance between the two electrodes must be at least six feet. However, in some systems the 25 ohms resistance value cannot achieve the goals of grounding. They require ground resistance values below ten ohms. If the main building load is composed of computers or sensitive electronic equipment, the earth ground resistance should not exceed five ohms. There are many methods of system grounding used in industrial and commercial power systems, the major ones being ungrounded, solid grounding, and low and high resistance grounding. Factors which influence the choice of selection include voltage level of the power system, transient overvoltage possibilities, types of equipment on the system, cost of equipment, required continuity of service, quality of system operating personnel, and safety consideration including fire hazards.

*d. Lightning protection.* Main lightning protection grounding requirements are dependent upon the structure, component, or system to be protected. See chapter 30 for detailed discussion of lightning protection systems.

*e. Electronic and computer grounds.* Grounding for all electronic systems, including computers and computer networks, is a special case of the equipment ground and the system ground carefully applied. In fact, grounding systems for electronic equipment are generally the same as for system ground with an additional requirement: the degree of performance required. Electronic equipment grounding systems must not only provide a means of stabilizing input power system voltage levels, but also act as the zero voltage reference point. However, the need to do so is not restricted to a low frequency of a few hundred hertz. Grounding systems for modern electronic installations must be able to provide effective grounding and bonding functions well into the high frequency megahertz range. Effective grounding at 50-60 Hz may not be effective at all for frequencies above 100 kilohertz. There are several aspects to the requirement for good grounding performance for electronic equipment, all of which are due to electrical circuit behavior. Good electronic system grounding performance is achieved with a properly laid out distribution of multipoint, well bonded grounding connections. This system can use bare, braided, sheet, or stranded copper conductors for grounding or bonding functions. This system requires conduit and equipment enclosure bonding at all junction points. In other words, simple metallic contact between the enclosures, wiring conduits, and power panels is not enough. The multipoint bonding provides low impedance grounding for the electronic equipment. The low impedance between the separate items of electronic equipment keeps the noise voltages at or near zero between them and, therefore, provides an "equipotential plane." This system is much easier to inspect and test. No special requirements must be met during modifications or expansion of the electrical system. All power panels and all supply transformers feeding an installation with this type of grounding system must be grouped and bonded together using short lengths of bare, braided, sheet, or stranded copper conductors in order to achieve the effective high frequency grounding performance described above. A single area of power entry with a large equipotential ground plane and short equipment grounding conductors forms the preferred grounding system for large automated data processing (ADP) and computer applications.

*f. Maintenance safety grounds.* Grounds used for maintenance work are usually intentional, but temporary, connections between equipment power conductors and ground. These connections are always applied after the power source has been turned off and the circuit(s) have been tested and are known to be de-energized. The ground is intended to protect maintenance personnel from an inadvertent re-energization of the circuit. The ground is removed after maintenance operations have been completed.

#### **29-4. Ground system materials and testing requirements**

Several factors can degrade initial good grounds. These factors indicate the importance of continuous periodic testing of grounding systems. For example, water tables are gradually falling in many areas. Also, there are more underground installations of non-metallic pipes and conduits which do not provide low resistance ground connections. There are electric systems that are continually expanding with an associated fault current increase which may require a decrease in grounding resistance. And there are corroded connections that may increase the resistance of the ground system.

*a. Testing.* Periodic testing should be done to assure grounding system effectiveness. The following are points that should be addressed during inspection and maintenance:

(1) Inspect and test single point, isolated ground systems after every electrical system modification. Visually inspect outlets and panels for conductors forming loops between the equipment ground and the isolated ground.

(2) Test the ground to neutral voltage at each power distribution panel included in the particular system. The voltage should be taken using a high impedance AC voltmeter and an accurate record should be kept. The voltage should be very low; on the order of 10-150 millivolts (0.01-0.150V). Any sudden changes or increasing trends should be investigated and the cause corrected.

(3) The made electrode, rod, plate, or selected ground body contact point should be tested every 12-24 months. A record should be kept. Any increasing impedance indicates a need for remedial action.

*b. Piping systems.* The ground grid of the plant should be the primary system. In some cases a metallic underground water piping system may be used in lieu of a plant ground grid, provided adequate galvanic and stray current corrosion protection for the piping is installed, used, and tested periodically. This practice is not acceptable in hazardous areas and is not recommended if the piping system becomes sacrificial.

*c. Resistance goals.* The plant ground grid should have a system resistance of 10 ohms or less. Ground grid system resistance may be decreased by driving multiple ground electrode rods. A few rods, deeply driven and widely spaced, are more effective than a large number of short, closely spaced rods. Solid hard copper rods should be used, not copper plated steel. When low resistance soils are deep, the surface extension rods may be used to reach the low resistance stratum. Bonding of ground conductors to rods should be by permanent exothermic weld (preferred) or compression sleeve, and not by bolted clamp (corrosion results in high resistance connection). Resistance at each rod in a multiple system should not exceed 15 ohms.

*d. Ground rods.* Grounding electrodes (driven into the earth) maintain ground potential on all connected conductors. This is used to dissipate (into the earth) currents conducted to the electrodes. The resistance of a ground electrode is primarily determined by the earth surrounding the electrode. Test data given in IEEE 142, IEEE Recommended Practice for Grounding of Industrial and Commercial Power Systems (1991), indicate that about 90 percent of the total resistance of a ground lies within 6 to 10 feet (1.8 to 3 meters) from the electrode. The diameter of the rod has only a negligible effect on the resistance of a ground. The resistance of the soil is dependent upon the type of soil and its moisture content. Electrodes should be long enough to penetrate a relatively permanent moisture level and should extend well below the frost line.

## CHAPTER 30

# LIGHTNING PROTECTION

---

### 30-1. General lightning protection systems

Lightning protection is essential for the protection of humans, structures, contents within structures, transmission lines, and electrical equipment from thermal, mechanical, and electrical effects caused by lightning discharges. Lightning cannot be prevented, but it can with some success be intercepted, and its current can be conducted to a grounding system without side flashes where it is harmlessly dissipated.

### 30-2. Lightning effects on power systems

Lightning surges entering a power system through direct strokes are the primary concern in planning surge protection. These strokes may hit phase conductors directly, or they may strike the overhead ground wires or masts that shield the conductors. In either case, it is necessary to understand the associated surge currents and voltages produced before a protection system can be designed.

*a. Flashover.* A lightning stroke terminating directly on phase conductors or equipment terminals develops a very high voltage, which, with no surge protection, will flash over the insulation in the majority of cases. If the flashover occurs through air or across porcelain insulation, it rarely causes permanent damage. If, on the other hand, the flashover occurs through solid insulation such as in a transformer or cable, permanent damage results.

*b. Shielding.* The magnitude of surge voltages applied to equipment and line insulation systems can be limited by providing grounding masts or ground wires to intercept direct strokes. Even with a shielding network, though, there is some chance of flashover, depending on stroke current magnitude, impedance of the shielding system, and the amount of insulation between the network and the energized circuits.

*c. Induced surges.* A lightning stroke terminating near a transmission line can induce a voltage in the circuit that seldom exceeds 500 kV. Lines, shielded with overhead ground wires and operating at 69 kV and above, generally have sufficient insulation to prevent flashover by voltages in this range. The same applies to some well insulated 34.5 kV lines. Lower voltage lines, however, with insulation levels appreciably below 500 kV, may be flashed over by induced surges. In most cases, these circuits do not have ground wires, and are, therefore, subject to flashover each time they are contacted by a direct stroke. In general, flashovers by induced surges do not create a significant problem since the number of flashovers from direct strokes far exceeds those from induced strokes.

*d. Traveling waves.* A lightning stroke terminating on a power system initiates traveling waves that propagate within the system. To determine the resulting surge voltages and currents in various parts of the system, a traveling wave analysis is required. Simple networks with linear impedances can be analyzed manually; more complicated networks, characteristic of practical power systems, require analog or digital computer analysis.

*e. Surge voltages.* In protecting power systems against lightning, surge voltages and currents must be considered. In general, lightning protection is primarily concerned with surge voltages; surge currents cause less concern. A lightning stroke to a power system develops very high surge voltages across equipment and line insulation systems. If these voltages exceed the insulation strength, a flashover occurs.

Once lightning enters a power system, the surge current is unlikely to cause any damage. Although the current may be extremely high, it is very short lived and can easily be handled by a small conductor. The largest recorded conductor to be fused or vaporized by a direct stroke was an American Wire Gage (AWG) No. 10. The size of conductors, installed expressly for conducting lightning currents, is usually determined by mechanical strength considerations, rather than by current-carrying capacity. On some rare occasions, overhead ground wires have been severed by lightning at the point of contact. This is probably due to the stroke channel heating the conductor at the point of impingement, rather than from simply conducting the lightning current.

### 30-3. Principles of protection

Main lightning protection requirements are dependent upon the structure, component, or system to be protected. According to National Fire Protection Association (NFPA) 780, Standard for Installation of Lightning Protection Systems (1997), there are two classifications for a building. Class I is a building with less than 75 feet height. The Class II building is higher than 75 feet or has a steel frame with any height.

*a. Shielding.* Shielding masts are commonly used in substations, and overhead ground wires are used in both substations and on transmission lines. Both use the lightning rod principle. The voltage at the top of the mast is significantly less than the 2,000 kV that would be developed for the same stroke on a conductor. Grounded masts and grounded wires, then, offer an important reduction in the magnitude of surge voltages.

*b. Arresters.* Even with an effective shielding system, the surge voltages must be limited to magnitudes consistent with practical and economical equipment insulation levels to allow for voltages developed by strokes to the shielding network. On rare occasions, strokes may also bypass the shielding system and terminate directly on the energized circuits. For these situations, an arrester is used to control and limit surge voltages to a safe level. The arrester, applied on or near the terminals of the protected equipment, is connected from phase to ground. Under normal operating conditions, the arrester has no effect on the power system. Under surge conditions, the arrester will spark over and conduct the surge current to ground, limiting the voltage applied to the equipment insulation to a safe level. After conducting the surge current to ground, the arrester will interrupt the power-follow current and restore itself to its normal operating conditions. There are two general types of arrester designs: valve type and expulsion type. The valve type has one or more sets of spark gaps (series connected) which establish spark-over voltage, interrupt the flow of current, and prevent high current flow. The expulsion type has an arc-extinguishing chamber in series with the gaps to interrupt the power frequency current that flows after the gaps have been sparked over. Design refinements include using oxide film coated components and sealing the inner components in a chamber filled with an inert gas. Aluminum cells are used in some units.

*c. Air terminals.* Air terminals are used to intercept lightning discharges above facilities. Air terminals will be in accordance with Underwriters Laboratories, Inc. (UL) 96, UL Standard for Safety Lightning Protection Components, Fourth Edition (2000), and 96A, UL Standard for Safety Installation Requirements for Lightning Protection Systems, Tenth Edition (1998), NFPA 780, or MIL-HDBK-419A, Grounding, Bonding, and Shielding. Where building roof is not metal and building construction includes steel framing, air terminal connection assemblies are required.

*d. Grounding.* Grounding generally will conform to NFPA 780, unless otherwise specified. Guidance for grounding for purposes such as electromagnetic pulse (EMP), electromagnetic interference (EMI) shielding, and electronic facility grounding, are subjects of other engineering manuals that govern grounding requirements. Those grounding systems will also serve as grounding of the lightning protection system. Where separate systems are installed, such systems will be bonded below grade to any other

independently installed exterior grounding system such as for EM shielding not suitable for complete lightning protection system. However, exterior protection grounding system will be bonded to static electricity exterior grounding system.

*e. Ground rods.* Ground rods are generally not less than 10 feet in length, nor less than 3/4-inch diameter pipe or equivalent solid rod. Rods are driven so that tops are at least six inches below finished grade, and three to eight feet beyond perimeter of building foundation. Where ground rods are used with a counterpoise, tops are driven to same elevation as counterpoise below finished grade. Contact with chemically injurious wastewater or other corrosive soils is avoided. Where avoidance of chemically injurious or corrosive soils is impracticable, stainless steel rod and magnesium anode protection is used. Where buried metal pipes enter a building, the nearest ground rod will be connected thereto.

*f. Counterpoise.* Each earth electrode subsystem or counterpoise consists of one or more closed loops or a grid arrangement of No. 1/0 AWG bare copper conductors installed around facility perimeter not less than 2 feet below earth surface. Larger conductors should be used when installed in highly corrosive soils. A second loop, if used, should not be less than 10 feet beyond the first and inner loop. At least two ground rods are provided at each corner of each counterpoise loop where earth-seeking current tend to concentrate. Counterpoise will extend not less than 3 feet nor more than 8 feet beyond the perimeter of building walls or footings.

*g. Radial systems.* A radial system of grounding consists of one or more No. 1/0 AWG copper conductors not less than 12 feet long, extending away from each ground rod or grounding connection. The use of multiple radials is an effective form of grounding, offering substantially lower reactance to the high frequency of lightning current wave fronts than do single straight conductors. Installation of grounding radials takes advantage of crags and cracks in surface rock formations in obtaining maximum available earth cover.

*h. Structural components.* Lightning protection is provided on the outside of exterior surfaces without reliance upon components of the building for conductors. Reinforcement steel may be used for down conductors in conformance with NFPA 780 and if approved by the using agency. Joints are made in no fewer than every fifth reinforcement rod and at corners of buildings. Joints are made electrically conductive and are connected top and bottom for connections to roof conductors and to grounding electrodes, respectively. Grounding pigtailed from bottoms of reinforcement fabric are connected to exterior grounding system at same or lower elevation as that where pigtailed leave walls and footings.

#### **30-4. Lightning protection systems equipment requirements**

All system components are made of copper, anodized aluminum, or stainless steel. Standard down conductors are usually large bare copper or aluminum stranded conductors that are constructed particularly for the lightning protection industry. A recent advancement is a coaxial cable that reduces the surge impedance as well as flashover. However, this cable is more costly than the conventional conductors. Interconnecting conductors are as important as other components. Tests in high-voltage laboratories demonstrate that a steep voltage wave front, such as created by lightning, causes the surge impedance in conventional conductors to increase to the point that side flashes occur. Installation of multiple grounding conductors for buildings and a roof grid system creating a faraday cage reduces the magnitude of current flow in any one conductor. However, side flashes can still occur.

## CHAPTER 31

### CATHODIC PROTECTION

---

#### 31-1. General cathodic protection systems

Cathodic protection is a system utilized to inhibit corrosion of structures, such as underground pipes, tanks, etc. Corrosion is an electrochemical process in which a current leaves a structure at the anode site, passes through an electrolyte, and reenters the structure at the cathode site. For example, because it is in a soil with low resistivity compared to the rest of the line, current would leave the pipeline at that anode site, pass through the soil, and reenter the pipeline at a cathode site. Current flows because of a potential difference between the anode and cathode. The anode potential is more negative than the cathode potential, and this difference is the driving force for the corrosion current. The total system – anode, cathode, electrolyte, and metallic connection between anode and cathode is termed a corrosion cell. For corrosion to occur, the following conditions are required.

- a. *Electrodes.* An anode and cathode must be present.
- b. *Electrical potential.* An electrical potential between the anode and cathode must be present. Several conditions may cause this potential.
- c. *Conductive path.* A metallic conductive path electrically connecting the anode and cathode must exist. In the case of a metallic pipeline, the pipe itself is this conductive path.
- d. *Electrolyte.* The anode and cathode are immersed in an electrically conductive electrolyte that is ionized. Usual soil moisture or water fulfills this condition.
- e. *Current.* When these conditions exist, an electric current will flow, and where the current leaves a metallic object, metals will be consumed. Cathodic protection reverses the current flow by installing ground beds of sacrificial anodes. No longer does the current leave the structure. Now the structure receives current flow, inhibiting corrosion. The structure is the cathode, and thus, the term cathodic protection.

#### 31-2. Types of cathodic protection systems

Cathodic protection is a method to reduce corrosion by minimizing the difference in potential between anode and cathode. This is achieved by applying a current to the structure to be protected (such as a pipeline) from some outside source. When enough current is applied, the whole structure will be at one potential; thus, anode and cathode sites will not exist. Cathodic protection is commonly used on many types of structures, such as pipelines, underground storage tanks, locks, and ship hulls. There are two main types of cathodic protection systems: galvanic and impressed current.

- a. *Galvanic systems.* A galvanic cathodic protection system makes use of the corrosive potentials for different metals. Without cathodic protection, one area of the structure exists at a more negative potential than another, and corrosion results. If, however, a much less inert object (that is, with much more negative potential, such as magnesium anode) is placed adjacent to the structure to be protected, such as a pipeline; and a metallic connection (insulated wire) is installed between the object and the structure, the object will become the anode and the entire structure will become the cathode. That is, the new object

corrodes sacrificially to protect the structure. Thus, the galvanic cathodic protection system is called a “sacrificial anode cathodic protection system” because the anode corrodes sacrificially to protect the structure. Galvanic anodes are usually made of either magnesium or zinc because of these metals higher potential compared to steel structures.

*b. Impressed current systems.* Impressed current cathodic protection systems use the same elements as the galvanic protection system, only the structure is protected by applying a current to it from an anode. The anode and the structure are connected by an insulated wire, as for the galvanic system. Current flows from the anode through the electrolyte onto the structure, just as in the galvanic system. The main difference between galvanic and an impressed current system is that the galvanic system relies on the difference in potential between the anode and structure, whereas the impressed current system uses an external power source to drive the current. The external power source is usually a rectifier that changes input alternating current (AC) power to the proper direct current (DC) power level. The rectifier can be adjusted, so that proper output can be maintained during the system’s life. Impressed current cathodic protection system anodes typically are high-silicon cast iron or graphite.

### 31-3. Application of cathodic protection

Before deciding which type, galvanic or impressed current, cathodic protection system will be used and before the system is designed, certain preliminary data must be gathered.

*a. Dimensions.* One important element in designing a cathodic protection system is the structure's physical dimensions (for example, length, width, height, and diameter). These data are used to calculate the surface area to be protected.

*b. Layout.* The installation drawings must include sizes, shapes, material type, and locations of parts of the structure to be protected.

*c. Insulators.* If a structure is to be protected by the cathodic system, it must be electrically connected to the anode. Sometimes parts of a structure or system are electrically isolated from each other by insulators. For example, in a gas pipeline distribution system, the inlet pipe to each building might contain an electric insulator to isolate in-house piping from the pipeline. Also, an electrical insulator might be used at a valve along the pipeline to electrically isolate one section of the system from another. Since each electrically isolated part of a structure would need its own cathodic protection, the locations of these insulators must be determined.

*d. Short circuits.* All short circuits must be eliminated from existing and new cathodic protection systems. A short circuit can occur when one pipe system contacts another, causing interference with the cathodic protection system. When updating existing systems, eliminating short circuits would be a necessary first step.

*e. Corrosion history.* Studying the corrosion history in the area can prove very helpful when designing a cathodic protection system. The study should reinforce predictions for corrosivity of a given structure and its environment; in addition, it may reveal abnormal conditions not otherwise suspected. Facilities’ personnel can be a good source of information for corrosion history.

*f. Electrolyte resistivity.* A structure's corrosion rate is proportional to the electrolyte resistivity. Without cathodic protection, as electrolyte resistivity decreases, more current is allowed to flow from the structure into the electrolyte; thus, the structure corrodes more rapidly. As electrolyte resistivity increases, the corrosion rate decreases. Resistivity can be measured either in a laboratory or at the site with the



proper instruments. The resistivity data will be used to calculate the sizes of anodes and rectifier required in designing the cathodic protection system.

*g. Electrolyte pH.* Corrosion is also proportional to electrolyte pH (see glossary for definition of pH and other terms). In general, steel's corrosion rate increases as pH decreases when soil resistivity remains constant. For existing structures, the potential between the structure and the electrolyte will give a direct indication of the corrosivity. According to National Association of Corrosion Engineers (NACE) Standard RP-0169, Control of External Corrosion on Underground or Submerged Metallic Piping Systems (1996), the potential requirement for cathodic protection is a negative (cathodic) potential of at least 0.85 volt as measured between the structure and a saturated copper-copper sulfate reference electrode in contact with the electrolyte. A potential that is less negative than -0.85 volt would probably be corrosive, with corrosivity increasing as the negative value decreases (becomes more positive).

*h. Current density.* A critical part of design calculations for cathodic protection systems on existing structures is the amount of current required per square foot (called "current density") to change the structure's potential to -0.85 volt. The current density required to shift the potential indicates the structure's surface condition. A well coated structure (for example, a pipeline well coated with coal-tar epoxy) will require a very low current density (about 0.05 milliamperes per square foot); an uncoated structure would require high current density (about 10 milliamperes per square foot). Current requirements can be calculated or estimated based on coating efficiency and current density (current per square foot) desired. The efficiency of the coating as supplied will have a direct effect on the total current requirement. Coating efficiency is directly affected by the type of coating used and by quality control during coating application. The importance of coating efficiency is evident in the fact that a bare structure may require 100,000 times as much current as would the same structure if it were well coated. Caution should be used when estimating, however, as underprotection or overprotection may result. A coating's resistance decreases greatly with age and directly affects structure-to-electrolyte resistance for design calculations. The coating manufacturers supply coating resistance values.

*i. Verification of need.* For existing structures, the current requirement survey will verify the need for a cathodic protection system. For new systems, standard practice is to assume a current density of at least 2 milliamperes per square foot of bare area will be needed to protect the structure. However, local corrosion history may demand a different current density. In addition, cathodic protection is *mandatory* for underground gas distribution lines (Department of Transportation regulations - Title 49, *Code of Federal Regulations*) and for water storage tanks with a 250,000-gallon capacity or greater. Cathodic protection also is required for underground piping systems located within 10 feet of steel reinforced concrete because galvanic corrosion will occur between the steel rebar and the pipeline.

### **31-4. Cathodic protection system design**

The process required to design a cathodic protection system is described below.

*a. Galvanic systems.* Eight steps are required for applying a galvanic protection system.

(1) The site of lowest resistivity will likely be used for anode location to minimize anode-to-electrolyte resistivity. In addition, if resistivity variations are not significant, the average resistivity will be used for design calculations.

(2) Galvanic anodes are usually either magnesium or zinc. Zinc anodes are used in extremely corrosive soil (resistivity below 2000 ohm-centimeters). Data from commercially available anodes must be reviewed. Each anode specification will include anode weight, anode dimensions, and package

dimensions (anode plus backfill). In addition, the anode's driving potential must be considered.

- (3) The net driving potential for the anodes must be determined.
- (4) Determine the number of anodes needed to meet groundbed resistance limitations.
- (5) Determine the number of anodes for the system's life expectancy
- (6) Select number of anodes to be used.
- (7) Select ground bed layout.
- (8) Determine the life-cycle cost for proposed design.

*b. Impressed current systems.* Eleven steps are required for applying an impressed current protection system.

- (1) Review soil resistivity.
- (2) Review current requirement test.
- (3) Select anode.
- (4) Determine the number of anodes needed to satisfy the current density limitations.
- (5) Determine the number of anodes for the system's life expectancy.
- (6) Determine the number of anodes needed to meet the maximum anode groundbed resistance requirements.
- (7) Select anodes to be used.
- (8) Select the area for placement of the anodes.
- (9) Determine the total circuit resistance.
- (10) Calculate the rectifier voltage.
- (11) Select a rectifier.

## CHAPTER 32

### BLAST PROTECTION AND DETECTION SYSTEM

---

#### 32-1. General blast protection and detection systems

Blast protection and detection systems guard hardened facilities from the effects of an attack external to the facility. These systems consist of blast sensors, relay panels, blast valve systems, blast door systems, and the electrical system.

#### 32-2. Sensors

Blast sensors are located in the control circuit of the valve closure system. These sensors are physically located on the exterior surface of the facility or opening to be protected. When a sudden increase in air pressure is sensed, as a result of an external explosion, the sensor activates the valve closure through a relay and also provides a visual and audible alarm.

#### 32-3. Relay panels

The relay panels in the blast system are a part of the electrical system and contain the relaying necessary for the controls of the protective functions afforded by the blast valve system.

#### 32-4. Blast valve systems

Blast valves are used as intake and outlet air ventilation valves in blast protected buildings to block out the destructive effects of explosions. All valve types are tested with multiple blast loads over the entire load range from high peaked short duration load to quasi-static long duration blast load.

*a. Mounting.* Self-acting blast valves consist of blast valve units and mountings. Openings and supports to accommodate the proposed valve system are designed using loads computed from the blast overpressures specified or indicated.

*b. Operation.* Blast valve units are installed in each opening of the facility and close under the positive blast overpressures specified or indicated and are fully operational after the blast. The actuation of the valve then seals the opening to prevent entry of undesirable environmental conditions and to allow the facility to remain habitable, protecting the safety of the facility occupants. Units operate under a zero rise time, with a sustained (infinite duration) blast overpressure. Casing-mounted exhaust valve units operate under a zero rise time, sustained (infinite duration) blast overpressure. Blast valve units are removable from casings or other mountings. Except for airflow openings, any penetrations through the valve system shall be sealed against blast leakage through the penetration. Valve casing supports are structural steel fabricated. Valves installed in piping systems are flange connected.

#### 32-5. Blast door systems

Entrances that do not incorporate decontamination facilities are provided with an airtight door behind a pair of blast proof exterior doors resulting in two contiguous chambers: a blast lock and a vestibule.

*a. Blast lock.* The blast lock between the blast doors allows opening of one blast door at a time. This permits ingress and egress without loss of interior air pressure, interruption of the blast protection, or direct entry of air into the facility. Mounted above the exterior blast door is a blast closure and above the inner blast door an anti-backdraft valve. These fittings are connected in series by a blast proof ceiling cavity above the blast lock. This allows continuous exhaust of air from the vestibule under a controlled pressure differential independently from the use of the blast lock.

*b. Vestibule.* The vestibule between the blast door and the airtight door is a pressurized and ventilated air lock that allows for dilution and exhaust of any outside air introduced in the vestibule by the movement of personnel through the inner blast door. Mounted above the airtight door separating the vestibule from the rest of the facility is an air pressure regulator to supply scavenging air to the vestibule under a controlled pressure differential.

## CHAPTER 33

### FIRE PROTECTION

---

#### 33-1. General fire protection systems

The fire protection system consists of basic fire suppression systems, such as automatic sprinklers and carbon dioxide systems, as well as fire detection and alarm systems. Halon systems are no longer used. The purpose of the system is to protect property and life from the consequences of a fire and to provide fire control until professional fire fighters arrive. Whether the combustion is controlled or extinguished by the suppression system depends on the hazard being protected against; the type of system selected to protect the hazard; the type of suppression agent selected; and of utmost importance, the design of the suppression system. It is imperative that the National Fire Protection Association (NFPA) Fire Code standards and manufacturer's recommendations relative to each suppression, detection, and alarm system be consulted before any operation or maintenance is performed on any of these systems.

#### 33-2. Fire detection systems

The concept of defense in depth is applied in fire protection when an early warning fire detection system is used to communicate plant or equipment status to a central location or assigned staff. The first line of defense is the early warning fire detection system designed to detect the particles of combustion formed before overt signs of fire appear, followed by systems designed to detect fire and release extinguishing agents. The system's purpose is to provide the earliest possible warning of a potential fire hazard, principally by the extensive use of ionization smoke detectors.

*a. Type of detectors.* The three basic types of detectors can detect smoke, heat, and flame.

(1) Two types of smoke detectors are used: ionization and photoelectric. Ionization smoke detectors contain a small amount of radioactive material which ionizes the air in the sensing chamber, thus rendering it conductive and permitting a current flow through the air between two charged electrodes. When smoke particles enter the ionization area, the detector circuit responds with an alarm or buzzing. Photoelectric spot type detectors contain a chamber that has either overlapping or porous covers of light that allows the entry of smoke. The unit contains a light source and a special photosensitive cell in the darkened chamber. The cell is either placed in the darkened chamber at an angle different from the light path or has the light blocked from it by a light stop or shield placed between the light source and the cell. With the admission of smoke particles, light strikes the particles and is scattered and reflected into the photosensitive cell. This causes the photosensing circuit to respond to the presence of smoke particles in the smoke chamber.

(2) Heat detectors can be configured as spot type or line type. In spot type detectors the sensing element is concentrated at a particular location. Line type detectors sense temperature changes along the length of a metal wire. When heat above a predetermined level reaches the lines strung throughout an area to be protected, an alarm or alarm and fire-suppression system is triggered. Heat detectors are fixed-temperature, rate-compensated, or rate-of-rise types. A fixed-temperature detector is a device that responds when its operating element becomes heated to a predetermined level or higher. A rate-compensated detector is a device that responds when the temperature of the air surrounding the device reaches a predetermined level, regardless of the rate of temperature rise. A rate-of-rise detector is a device that responds when the temperature rises at a rate exceeding a predetermined amount.

(3) A flame detector is a device that responds to the appearance of radiant energy visible to the human eye or to radiant energy outside the range of human vision.

(a) A photoelectric flame detector is a device that the sensing element is a photocell that either changes its electrical conductivity or produces an electrical potential when exposed to radiant energy.

(b) A flame flicker detector is a photoelectric flame detector with means to prevent response to visible light unless the observed light is modulated at a frequency characteristic of the flicker of a flame.

(c) An infrared detector is a device with a sensing element that is responsive to radiant energy outside the range of human vision.

(d) An ultraviolet detector is a device with a sensing element that is responsive to radiant energy outside the range of human vision.

*b. Signaling systems.* One of the major advantages of using a remote multiplexing system for fire detection is the ease of adding alarm detectors without the requirement of long conduit and multiple cable runs throughout the plant. The early warning fire detection system may be a Class A proprietary protective signaling system that meets the requirements of NFPA 72, National Fire Alarm Code. Class A fire detection means a fire alarm can be received and displayed at the central alarm station in the abnormal presence of a single break of a single ground fault in any signaling circuit. A Class B system does not include this emergency operating feature.

### 33-3. Fire suppression systems

Many types of fire suppression or extinguishing systems are available. Water spray provides cooling action, CO<sub>2</sub> reduces the oxygen concentration, isolation removes the fuel from the fire, and dry chemicals disrupt the unrestrained chemical chain reaction needed for combustion. However, not all extinguishing agents are equally effective and cost efficient in certain types of fires. Water used on electrical control equipment and terminal cabinets can cause damage by shorting. CO<sub>2</sub> is not cost effective in large volume areas, and the area is not immediately habitable after application. Another factor to consider is whether the suppression system should be activated by automatic or manual means. The consequences of a false trip of an automatic system can be as bad as a fire in that operations personnel may deactivate the system to preclude further trips.

*a. Water systems.* Protecting facilities from fire frequently requires the installation of a sprinkler system. Equipment consisting of overhead piping and attached sprinklers connected to an automatic water supply protects defined spaces and a variety of hazards. There are four major types of sprinkler systems: wet pipe, dry pipe, deluge, and pre-action.

(1) The wet pipe system is the simplest and most common. The wet pipe system utilizes a water-filled piping system connected to a water supply and is equipped with sprinklers having fixed temperature elements which each open individually when exposed to a high temperature due to a fire. The areas where wet pipe sprinkler systems will be used are heated shops, garages, warehouses, laboratories, offices, record rooms, locker rooms, lunch rooms, and toilets.

(2) The dry pipe type of system has heat operated sprinklers attached to a piping system containing air under pressure. When a sprinkler head operates, the air pressure is reduced, a "dry pipe" valve is opened by water pressure, and water flows to any opened sprinkler heads.

(3) The deluge type of system consists of open-type sprinkler heads attached to a network of dry (not water-filled) piping which is automatically controlled by a fully supervised fire detection system which also serves as a fire alarm system. When a fire is detected, an automatic deluge valve is tripped open, admitting water to the system to discharge through all of the sprinkler heads. The system may be subdivided into separately controlled headers, depending on the area to be covered and the number of sprinkler heads required. The usual pressure required at the sprinkler heads is about 175 psi and the piping should be properly sized accordingly. Water spray deluge sprinkler systems are provided where required in open areas and areas requiring the protection of the piping from freezing. Water deluge systems are provided for outdoor transformers, when the transformers are installed on or adjacent to the structure to help prevent the spread of fire and to limit damage to the structure and other close-by transformers and equipment.

(4) The pre-action type of system is similar to the above water spray deluge system, except that it contains closed type sprinkler heads which only discharge water through those sprinklers whose fixed temperature elements have been opened by the heat from a fire.

*b. Carbon dioxide.* This type of system usually consists of a truck filled low pressure refrigerated liquid carbon dioxide storage tank with temperature sensing controls to permit the automatic injection of permanently piped carbon dioxide into areas to be protected. The system usually includes warning alarms to alert personnel whenever carbon dioxide is being injected into an actuated area. Carbon dioxide extinguishing systems of this total flooding type will be utilized to extinguish coal bunker fires and for electrical hazard areas such as in battery rooms, electrical relay rooms, switchgear rooms, computer rooms, and within electrical cabinets.

*c. Foam extinguishing systems.* Foam fire extinguishing systems utilize a foam producing solution which is distributed by pipes equipped with spray nozzles or a fuel tank foam entry chamber for discharging the foam and spreading it over the area to be protected. It is principally used to form a coherent floating blanket over flammable and combustible liquids which extinguish (or prevent) a fire by excluding air and cooling the fuel. The foam is usually generated by mixing proportionate amounts of 3 percent double strength, low expansion standard foam concentrate using either a suitably arranged induction device with (or without) a foam storage-proportioning tank to mix the foam concentrate with a water stream from a fire water header. A tank foam chamber or open sprinklers aspirate the air to form the foam to blanket the area to be protected. The deluge water entry valve to the system may be manually or automatically opened. Foam systems will be installed in power plants to protect fuel oil areas, lubricating oil systems, and hydrogen seal oil systems.

*d. Portable fire extinguishers.* Portable hand held CO<sub>2</sub> fire extinguishers should be provided and located throughout the facility in accordance with the NFPA. The use of dry chemical fire extinguishers is not recommended, primarily due to cleanup problems.

## APPENDIX A

### REFERENCES

---

#### Required Publications

##### Government Publications

###### *Department of Defense:*

MIL-HDBK-419A

Grounding, Bonding, and Shielding for Electronic Equipment and Facilities (Cited in para 30-3c)

MIL-STD-882

System Safety Program Requirements (Cited in para 2-2c(1))

MIL-STD-1472

Human Engineering Design Criteria for Military System, Equipment, and Facilities (Cited in para 2-2b)

MIL-F-16884J

Fuel, Naval Distillate (Cited in para 5-3k)

###### *Department of Army:*

TM 5-692-1

Maintenance of Mechanical and Electrical Equipment at C4ISR Facilities, Recommended Maintenance Practices (Cited in para 1-1)

###### *Code of Federal Regulations:*

49 CFR 192

Transportation of Natural and Other Gas by Pipeline: Minimum Federal Safety Standards (Cited in para 31-3i)

###### *Other Government Documents:*

Federal Specification A-A-52557

Fuel Oil, Diesel; For Posts, Camps And Stations (Cited in para 5-3k)

Department of Transportation – Title 49

Code of Federal Regulations. Oct 1974 (Cited in para 31-3i)

##### Non-Government Publications

###### *American Society of Mechanical Engineers (ASME):*

345 East 47<sup>th</sup> Street, New York, NY 10017

ASME Boiler and Pressure Vessel Codes (Cited in para 10-2i)



## TM 5-692-2

ASME B31.1  
Power Piping (1998) (Cited in para 13-2d)

ASME B31.3  
Process Piping (1999) (Cited in para 6-2h)

ASME B36.10M  
Welded and Seamless Wrought Steel Pipe (1996) (Cited in para 6-2h(2))

*American Society for Testing and Materials (ASTM):*  
100 Barr Harbor Drive, West Conshohocken, PA 19428-2959

ASTM A 53  
Standard Specification for Pipe, Steel, Black and Hot-Dipped, Zinc-Coated, Welded and Seamless (1999) (Cited in para 6-2h(2), 11-2k, 12-2e(2)(d), 15-2h)

ASTM A 105  
Standard Specification for Carbon Steel Forgings for Piping Applications (1998) (Cited in para 6-2h(1))

ASTM A 106  
Standard Specification for Seamless Carbon Steel Pipe for High-Temperature Service (1999) (Cited in para 6-2h(2), 9-3j)

ASTM A 216  
Standard Specification for Steel Castings, Carbon, Suitable for Fusion Welding, for High-Temperature Service (1998) (Cited in para 6-2h(1))

*American Waterworks Association (AWWA):*  
6666 West Quincy Avenue, Denver, CO 80235

AWWA C104  
Cement-Mortar Lining for Ductile-Iron Pipe and Fittings for Water (1995) (Cited in para 12-23(2)(e))

*Institute of Electrical and Electronic Engineers (IEEE):*  
445 Hoes Lane, P. O. Box 1331, Piscataway, NJ 08855-1331

IEEE C57.12.80  
Standard Terminology for Power and Distribution Transformers (1992) (Cited in para 20-2a(3))

IEEE C37.2  
Standard Electrical Power System Device Function Numbers and Contact Designations (1996) (Cited in para 25-2g)

IEEE C37.90  
Standard for Relays and Relay Systems Associated with Electric Power Apparatus (1994) (Cited in para 25-2f(3))

IEEE 142  
IEEE Recommended Practice for Grounding of Industrial and Commercial Power Systems (1991) (Cited in para 29-4d)

Kazan (1994) (Cited in para 17-2b(2))

*National Association of Corrosion Engineers*  
1440 South Creek Drive, Houston, TX 77084

NACE RP0169

Control of External Corrosion on Underground or Submerged Metallic Piping Systems (1996) (Cited in para 31-3g)

*National Association of Plumbing-Heating-Cooling Contractors* (Cited in figure 18-3)

*National Fire Protection Association (NFPA):*

One Batterymarch Park, P. O. Box 9101, Quincy, MA 02269-9101

NFPA 30

Flammable and Combustible Liquid Code (1996) (Cited in para 6-2b)

NFPA 70

National Electrical Code (Cited in para 20-2a(3), 29-3c)

NFPA 72

National Fire Alarm Code (1999) (Cited in para 33-2b)

NFPA 780

Standard for Installation of Lightning Protection Systems (1997) (Cited in para 30-3, 30-3c, 30-3d, 30-3h)

*Underwriters Laboratories, Inc. (UL)*

333 Pfingsten Road, Northbrook, IL 60062-2096

UL 555S

Smoke Dampers Fourth Edition (1999) (Cited in para 14-2m(4))

UL 96

Lightning Protection Components, Fourth Edition (2000) (Cited in para 30-3c)

UL 96A

Installation Requirements for Lightning Protection Systems, Tenth Edition (1998) (Cited in para 30-3c)

## **Related Publications**

*Department of the Army*

TM5-691 Utility System Design Requirements for Command, Control, Computer, Intelligence, Surveillance, and Reconnaissance (C4ISR) Facilities

## GLOSSARY

---

### Abbreviations

**AC**

Alternating Current

**ADP**

Automated Data Processing

**Ah**

Ampere-hour

**ANSI**

American National Standards Institute

**ASME**

American Society of Mechanical Engineers

**ASTM**

American Society for Testing and Materials

**AWG**

American Wire Gage

**AWWA**

American Waterworks Association

**BTU**

British Thermal Unit

**C4ISR**

Command, Control, Communications, Computer, Intelligence, Surveillance, and Reconnaissance

**C**

Centigrade

**CBR**

Chemical, Biological, and Radiological

**cm**

Centimeter

**CI**

Cast Iron

**CP**

Cathodic Protection

**CPU**  
Central Processing Unit

**d**  
day/days/daily

**DC**  
Direct Current

**DOD**  
Department of Defense

**EM**  
Electromagnetic

**EMC**  
Electromagnetic Compatibility

**EMCS**  
Energy Management Control Systems

**EMF**  
Electromotive Force

**EMI**  
Electromagnetic Interference

**EMP**  
Electromagnetic Pulse

**EPA**  
Environmental Protection Agency

**ESS**  
Electronic Security Systems

**F**  
Fahrenheit

**FID**  
Field Interface Device

**HAD**  
Heat Actuator Detector

**HEMP**  
High Altitude Electromagnetic Pulse

**HFE**  
Human Factors Engineering

**HPM**  
High Power Microwave

**hr**  
hour/hours/hourly

**HVAC**  
Heating, Ventilating, and Air Conditioning

**HVAC&R**  
Heating, Ventilating, Air Conditioning & Refrigeration

**Hz**  
Hertz

**IEEE**  
Institute of Electrical and Electronics Engineers

**IDS**  
Intrusion Detection System

**IGBT**  
Insulated Gate Bipolar Transistor

**K**  
Thousand

**kg**  
Kilogram

**km**  
Kilo Meter

**kVA**  
Kilo Volt Amperes

**kW**  
Kilo Watts

**LAN**  
Local Area Network

**LC**  
Line-commutated (inverter)

**NACE**  
National Association of Corrosion Engineers

**NEC**  
National Electrical Code

**NFPA**

National Fire Protection Association

**NPDES**

National Pollutant Discharge Elimination System

**O&M**

Operations and Maintenance

**ppm**

Parts Per Million

**psig**

Pounds Per Square Inch, Gage

**PVC**

Polyvinyl Chloride

**PWM**

Pulse Width Modulated

**R/A**

Reliability/Availability

**RAM**

Reliability, Availability, and Maintainability

**RF**

Radio Frequency

**RFI**

Radio Frequency Interference

**RMG**

Roesel Motor Generator

**RMS**

Root Mean Square

**s**

Second

**SCADA**

Supervisory Control and Data Acquisition

**SCR**

Silicon Controlled Rectifier

**SE**

Systems Engineering

**SF<sub>6</sub>**  
Sulfur Hexafluoride

**THD**  
Total Harmonic Distortion

**TIMA**  
Thermal Insulation Manufacturers Association

**TM**  
Technical Manual

**UL**  
Underwriters Laboratories

**UPS**  
Uninterruptible Power Supply

**UWB**  
Ultra Wide Band

**VAR**  
Volt-Ampere Reactive

The proponent agency of this publication is the Chief of Engineers, United States Army. Users are invited to send comments and suggested improvements on DA Form 2028 (Recommended Changes to Publications and Blank Forms) directly to HQUSACE, (ATTN: CEMP-SP), Washington, DC 203 14- 1000.

By Order of the Secretary of the Army:

Official:

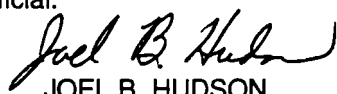

JOEL B. HUDSON

*Administrative Assistant to the  
Secretary of the Army*

ERIC K. SHINSEKI  
*General, United States Army  
Chief of Staff*

Distribution:

To be distributed in accordance with Initial Distribution Number (IDN) 3447 19, requirements for non-equipment TM 5-692-2.





DISTRIBUTION LIST FOR CEMP-SP TECHNICAL MANUALS – 7 March, 2001

Commander, AMC Installations & Services Activity  
ATTN: AMXEN  
1 Rock Island Arsenal  
Rock Island, IL 61299-7190

Commander, US Army Forces Command  
ATTN: AFPI-EN  
Fort McPherson, GA 30330-6000

Commander, US Army Training & Doctrine Command  
ATTN: ATBO-GF  
Bldg 5E, North Gate Rd.  
Fort Monroe, VA 23651-1048

Commander, US Army Medical Command  
ATTN: MCFA  
Fort Sam Houston, TX 78234-6000

Commander, US Army Military District of Washington  
ATTN: ANEN  
Fort McNair, Washington DC 20319-5050

Commander, US Army Pacific  
ATTN: APEN  
H Street, Bldg 104  
Fort Shafter, HI 96858-5100

Commander, US Army South  
ATTN: SOEN  
PO Box 34000  
Fort Buchanan, PR 00934-3400

Commander, US Army Intelligence & Security Command  
ATTN: IALOG-I  
Fort Belvoir, VA 22060-5246

Commander, US Army Europe & 7th Army  
ATTN: AEAEN-PW-FE  
Unit #29351  
APO, AE 09014

Headquarters, Eighth US Army Engineer  
ATTN: FKEN  
Unit #15236  
APO, AP 96205-0009

Commander, US Army Space & Missile Defense Command  
ATTN: SMDC-EN  
Huntsville, AL 33807-3801

Headquarters, Military Traffic Management Command  
ATTN: MTPAL-FE  
Hoffman II, 20 Stoval St.  
Alexandria, VA 22332-5000

Commander, US Army Special Operations Command  
ATTN: AOEN  
DCS Engineering  
Fort Bragg, NC 28310

Commander, US Army Criminal Investigation Command  
ATTN: CESP-EN  
6010 6<sup>th</sup> Street  
Fort Belvoir, VA 22060-5506

Commander, US Army Reserve Command  
ATTN: DAAR-EN  
1421 Jeff Davis Hwy  
Arlington, VA 22202-3259

Superintendent, US Military Academy  
ATTN: MAEN  
West Point, NY 10996-1592

DISC 4  
ATTN: SAIS-C4S (Mr. Ayala)  
107 Army Pentagon  
Washington, DC 30310-0107

Navy Public Works Center  
ATTN: Code 09K (Chris Chaffin)  
9742 Maryland Ave.  
Norfolk, VA 23511-3095

Naval Facilities Engineering Center  
ATTN: Code 242 (Randy Culberson)  
560 Center Drive  
Pt. Hueneme, CA 93043-4328

Commander, White Sands Missile Range  
ATTN: STEWS-DPW-DE (Julian Delgado)  
White Sands, NM 88002-5076

Engineering, Dept. of the Army  
PO Box 26  
Kwajalein Atoll  
APO, San Francisco 96555

Defense Intelligence Agency  
ATTN: RLE-1 (John Holmgren)  
Washington, DC 20340-3202

Facility Engineer, DCEETA  
ATTN: Greg Hopfer  
Ft. Belvoir, VA 22060

DISC4  
ATTN: SAIS-C4S (Charles Jerzak)  
107 Army Pentagon  
Washington DC 30310-0107

Dept. of State, Rosslyn Station  
ATTN: A/FBO/PE/BDE/EEB (Ahto Kivi)  
PO Box 12248  
Arlington, VA 22219

HQ DA ACSIM  
ATTN: Facilities Policy Division (John Krajewski)  
7701 Telegraph Rd.  
Alexandria, VA 22315-3800

US Army Signal Command  
ATTN: MOSC-SE (Hugh Mason)  
1670 Newport Rd. Ste 211  
Colorado Springs, CO 80916-2757

Sandia National Labs  
Electrical Analysis & Testing  
ATTN: Dept 2753 (Marvin Morris)  
Albuquerque, NM 87185-5800

Commander, US Army Yuma Proving Ground  
ATTN: STEYP-EH-P (Jack Nixon)  
Yuma, AZ 85365-9104

HQ, AFCES/ENE  
ATTN: Larry Strother  
139 Barnes Drive  
Tyndall AFB, FL 32403-5319

NAVFACENGCOM  
ATTN: Code 1652 (Bill Tayler)  
200 Stoval Street  
Alexandria, VA 22332