



**MAINTENANCE
OF
WATERFRONT
FACILITIES**

ARMY	TM-5-622
NAVY	MO-104
AIR FORCE	AFM 91-34

JUNE 1978

**DEPARTMENTS OF THE ARMY,
THE NAVY AND THE AIR FORCE**

NAVY:

SNDL: (2 copies each unless otherwise noted)

Part 1: 21A, 27G, 39B, 49, 51D1

Part 2: A1 (I&L only), A2A (ONR only), A3, A4A, A5, A6
B5 (Wash DC only-25 copies)
C4F9, C4F6, C4F8 (San Clemente and Fallbrook only), C4F36, C4K
E3A (Wash DC only), E3C
FA6, FA7, FA10, FA18, FA23, FA24, FA25 (10 copies)
FB6 (Atsugi only), FB7, FB10, FB13, FB21, FB26, FB28, FB30, FB33, FB34, FB36
FC1, FC3, FC4, FC5, FC7, FC12
FE4 (Chesapeake, Edzell, Adak, Hanza, Homestead, Sabana Seca, Skaggs Isl., Winter Harbor only)
FF1 (Wash DC only), FF3, FF19, FF38
FG2, FG3 (Cutter, Cheltenham, Thurso only), FG6 (Oahu only)
FKA1, FKA6A, FKA8,
FKM3, FKM8, FKM9 (Oakland only), FKM13, FKM15
FKN1 (25 copies), FKN2, FKN3, FKN5 (10 copies), FKN8, FKN10
FKP1B, FKP1E, FKP1J, FKP7 (5 copies), FKP14, FKP1M
FKR1A, FKR3C, FKR3G, FKR3H, FKR4B
FR1, FR3, FR4
FT1, FT6, FT22, FT28, FT37 (10 copies), FT55, FT73, FT78
V5, V8, V12, V16, V23

Additional copies may be obtained from:
U.S. Naval Publications and Forms Center
5801 Tabor Avenue
Philadelphia, PA 19120

AIR FORCE:

F

ARMY:

To be distributed in accordance with DA Form 12-34B, Requirements for TM 5-600 Series: Facilities Engineering: Maintenance and Operation of Facilities.

FOREWORD

This manual prescribes the criteria and procedures for inspection, maintenance, and repair of waterfront facilities at military installations. It establishes maintenance standards for and provides guidance for the selection, use, and installation of standard materials and equipment that will perform satisfactorily.

The use of the systems and procedures described in this publication, by personnel who have the responsibility for specifications, requisitions, procurement, inspection, storage, issue, application, and safety, should assure uniform, economical, and satisfactory maintenance and repair. When information in this publication varies from that contained in the latest issue of Federal or Military Specifications, the(se) Specification(s) shall apply. Reference to Federal, Military, or other Specifications is to the current issues of these specifications as identified by their basic number(s). In case of doubt, advice concerning any procedure may be obtained from:

- (1) Department of the Army Office of the Chief of Engineers DAEN-FEB
- (2) Department of the Navy Naval Facilities Engineering Command (1013) or its geographic Engineering Field Division (102)
- (3) Department of the Air Force Directorate of Engineering and Services AF/PRE

Recommendations or suggestions for modification, or additional information and instructions that will improve the publication and motivate its use, are invited and should be submitted through appropriate channels to the addresses listed above.

This publication supersedes Army TM-5-622 of 13 June 1946 and NAVDOCKS MO-104 of July 1963. It is certified that it has been reviewed and approved for official use in the Navy in accordance with Secretary of the Navy Instruction 5600.16.

By Order of the Secretaries of the Army, the Navy, and the Air Force:

BERNARD W. ROGERS
General, United States Army
Chief of Staff

Official:

J. C. PENNINGTON
Brigadier General, United States Army
The Adjutant General

D. G. ISELIN
Rear Admiral, CEC, US Navy, Command
Naval Facilities Engineering Command

DAVID C. JONES, General, USAF
Chief of Staff

Official:

JAMES J. SHEPARD, Colonel, USAF
Director of Administration

TABLE OF CONTENTS

	page
CHAPTER 1 - INTRODUCTION	
SECTION 1. GENERAL	1-1
Purpose.....	1-1
Scope.....	1-1
Cooperation and Coordination	1-1
SECTION 2. JOINT SERVICE RESPONSIBILITY.....	1-1
Army	1-1
Navy	1-2
Air Force.	1-2
SECTION 3. MAINTENANCE STANDARDS, POLICIES, AND CRITERIA	1-3
Standards.....	1-3
Engineering.....	1-3
Related Published Material.....	1-3
SECTION 4. TERMINOLOGY	1-4
Primary Considerations	1-4
Types of Structures	1-4
SECTION 5. PLANNING	1-9
Programming	1-9
Economic Requirement	1-9
Causes of Deterioration.....	1-9
Inspection.....	1-9
SECTION 6. PREPARATION FOR WORK.	1-10
Field Measurements.....	1-10
As-Built Drawings	1-10
Sketches	1-10
Checking Structural Stability.....	1-10
SECTION 7. ACCESS TO WORK.....	1-10
Divers.....	1-10
Rafts and/or Barges.....	1-10

	page
Scaffolds	1-11
Ladders	1-11
Excavations.....	1-12
SECTION 8. SAFETY	1-12
Instructions.....	1-12
Personal Protection	1-12
Barricades and Safety Lines	1-13
Traffic Control	1-13
Protection from Mechanical Damage.....	1-13
Berthing.....	1-13
Currents	1-13
Changes in Tides.....	1-14
 CHAPTER 2 - TIMBER STRUCTURES	
SECTION 1. PRESERVATION OF WOOD	2-1
Preservative Treatment.....	2-1
Wood Destroying Organisms.....	2-1
Preservative Materials.....	2-2
Pressure Treatment.....	2-4
Handling of Treated Wood.....	2-5
Seasoning Checks or Cracks.....	2-6
Hardware.....	2-6
SECTION 2. INSPECTION	2-6
Exposed Areas	2-6
Submerged Sections	2-7
SECTION 3. - MAINTENANCE	2-7
Replacement.....	2-7
Repair	2-12
 CHAPTER 3 - CONCRETE STRUCTURES	
SECTION 1. CONCRETE TECHNOLOGY.....	3-1

	page
Definition of Concrete.....	3-1
Components of Concrete.....	3-1
Desirable Properties of Concrete.....	3-2
Special Concretes for Waterfront Structures.....	3-3
SECTION 2. CAUSES AND TYPES OF DETERIORATION.....	3-5
Causes of Concrete Deterioration.....	3-5
Types of Concrete Damage.....	3-6
SECTION 3. METHODS OF INSPECTION.....	3-6
Visual.....	3-6
Mechanical.....	3-7
Electronic.....	3-8
SECTION 4. REPAIR METHODS.....	3-8
Introduction.....	3-8
Dry-Pack Mortar.....	3-9
Cast-In-Place Concrete.....	3-10
Shotcrete.....	3-13
Prepacked Concrete.....	3-13
Tremie Concrete.....	3-14
Pumped Concrete.....	3-14
Epoxy Resin.....	3-15
Protective Coatings.....	3-16
 CHAPTER 4 - STONE MASONRY STRUCTURES	
SECTION 1. INTRODUCTION.....	4-1
Background.....	4-1
Design.....	4-1
SECTION 2. METHOD OF INSPECTION.....	4-1
Visual.....	4-1
Settlement.....	4-1
Documentation.....	4-3

	page
SECTION 3. METHODS OF REPAIR	4-3
Engineering Investigation	4-3
Weep Holes	4-3
Shrinkage Cracks	4-3
Tuck-Pointing	4-3
Grouting	4-4
 CHAPTER 5 - RUBBLE-MOUND STRUCTURES	
SECTION 1. STRUCTURAL COMPONENTS	5-1
Mound	5-1
Rubble	5-1
Riprap	5-1
SECTION 2. CAUSES AND TYPES OF DETERIORATION	5-3
Types of Damage	5-3
Structural Damage	5-3
SECTION 3. INSPECTION	5-5
Components	5-5
Drainage	5-5
SECTION 4. METHODS OF REPAIR	5-5
As-Built Drawings	5-5
Replacing Components	5-5
 CHAPTER 6 - STRUCTURES INVOLVING SOIL	
SECTION 1. SOIL DESCRIPTION	6-1
Waterfront Use	6-1
Definition	6-1
Soil Classification	6-1
SECTION 2. SOIL PLACEMENT	6-2
Types of Soil	6-2
Compaction Control	6-2
Types of Compaction	6-3

	page
SECTION 3. INSPECTION	6-3
SECTION 4. REPAIR.....	6-3
Erosion.....	6-3
Sealing.....	6-4
Dewatering.....	6-4
Grouting.....	6-4
 CHAPTER 7 - STEEL STRUCTURES	
SECTION 1. CORROSION	7-1
Definition of Corrosion.....	7-1
Types of Marine Corrosion	7-1
SECTION 2. PROTECTIVE COATINGS	7-1
Protection.....	7-1
Surface Preparation	7-3
Recommended Coatings	7-3
Coating Application	7-3
Inspection of Coating.....	7-4
SECTION 3. CATHODIC PROTECTION.....	7-4
Definition.....	7-4
Types of Systems.....	7-4
SECTION 4. SUBSTITUTE MATERIALS FOR STEEL.....	7-5
Alloys	7-5
Plastics.....	7-6
Rubber	7-7
SECTION 5. INSPECTION	7-7
General Considerations.....	7-7
Inspection Techniques.....	7-7
Specific Structures	7-8
SECTION 6. MAINTENANCE OF STEEL STRUCTURES.....	7-15
Structural Considerations	7-15

	page
Piling.....	7-16
Supporting Components.....	7-19
Utility Lines.....	7-19
Mooring Fittings.....	7-20
Drydocks.....	7-20
Floating Structures.....	7-20
 CHAPTER 8 - PLASTIC AND ELASTOMERIC STRUCTURES	
SECTION 1. TYPES OF MATERIALS.....	8-1
Fiberglass- Reinforced Plastics.....	8-1
Foams.....	8-1
Rubbers.....	8-1
Plastic Wraps.....	8-1
Adhesives and Putties.....	8-4
SECTION 2. CONSTRUCTION TECHNIQUES.....	8-4
Lay-Up Construction.....	8-4
Spray-Up Construction.....	8-4
Filament Winding.....	8-4
Foaming In-Place.....	8-4
Pier Wrapping.....	8-4
Patching In-Place.....	8-4
REFERENCES.....	Reference-1
GLOSSARY.....	Glossary-1
Appendix A - Diver Inspection of Structures.....	A-1
Appendix B - Inspection, Documentation, Maintenance, and Certification of Graving Docks.....	B-1
INDEX.....	Index-1

FIGURES

No.		page
1-1	Open-type pier	1-5
1-2	Example of a wharf	1-5
1-3	Example of a dolphin	1-5
1-4	Graving dock with ship installed	1-6
1-5	Example of a marine railway	1-6
1-6	Example of a vertical lift drydock	1-6
1-7	A quaywall	1-7
1-8	Example of a mole	1-7
1-9	Example of a jetty	1-7
1-10	Example of the placement of a breakwater.....	1-8
1-11	A groin	1-8
1-12	Example of a seawall	1-8
2-1	Example of brown rot	2-1
2-2	Destruction of wooden piers by marine borers	2-2
2-3	Bankia (shipworm) infestation of wood planking	2-3
2-4	Surface of creosoted piling infested with Limnoria	2-3
2-5	Pier components	2-4
2-6	Fire-curtain wall.....	2-6
2-7	Wood pile replacement	2-8
2-8	Stringer splice	2-9
2-9	Repair of string piece	2-10
2-10	100% deterioration of chocks, lower wales, and fender piles	2-11
2-11	Replacing tops of piles	2-12
2-12	A flexible PVC barrier installed on wooden piles.....	2-13
2-13	Fender pile repair	2-14
3-1	Effect of water/cement ratio on 28-day compressive, flexural, and tensile strengths.....	3-3
3-2	Exposure zones	3-5
3-3	Concrete piles in advanced stage of deterioration	3-7
3-4	Sawtooth bit used to cut a slot for dry-packing	3-9
3-5	Excavation of irregular area of defective concrete where top of hole is cut at two levels.....	3-11
3-6	Details of forms for concrete replacement in bulkheads.....	3-12
3-7	Typical squeeze-type concrete pump	3-15
4-1	Masonry graving dock	4-2
4-2	Types of deterioration that will require repair	4-2
5-1	Concrete armor units.....	5-2
5-2	Cross section of semipermeable rubble-mound groin	5-4
5-3	Rubble-mound breakwater	5-4
5-4	Cave-in, indicating settlement of mole	5-6
5-5	The grouted sheathing of face of a breakwater, which is exposed to storms	5-7
7-1	Galvanic system of cathodic protection	7-5
7-2	Impressed current system of cathodic protection	7-5

FIGURES (continued)

No.		page
7-3	Typical example of corrosion damage to sheet piling	7-9
7-4	Hole in sheet piling causing soil subsidence	7-9
7-5	Example of utility line properly emplaced	7-9
7-6	Examples of mooring fittings.....	7-16
7-7	Repair of corroded steel pile.....	7-17
7-8	Concrete-protected steel sheet piling.....	7-18
7-9	Repairing tie rods.....	7-19
8-1	Fiberglass-reinforced plastic mooring buoy	8-2
8-2	Pontoon filled with urethane foam to impart buoyancy.....	8-2
8-3	Synthetic rubber molded into pile cap. Shape keeps birds from landing and snow from collecting.....	8-3
8-4	PVC barrier being installed around marine-borer-damaged pile.....	8-3
A-1	Cross section of piles with different damage ratings	A-5
B-1	Designation of drydock features	B-5

TABLES

3-1	Relationship Between Methods of Expressing Water-to- Cement Ratio	3-2
3-2	Gradation of Aggregates for Tremie Concrete	3-4
7-1	Types of Corrosion	7-2
7-2	Inspection Checkpoints for Utility Distribution Systems.....	7-10
A-1	Inspection of Specific Structures	A-3
B-1	Inspection Frequencies	B-6
B-2	Inspection Checkoff List	B-7
B-3	Coating Systems for Maintenance of Drydocking Facilities.....	B-17

CHAPTER 1 - INTRODUCTION

SECTION 1. GENERAL

1.1.1 PURPOSE. This manual is a guide for military personnel and civilian forces who are concerned with the maintenance and repair of waterfront structures and related facilities.

1.1.2 SCOPE. This manual, together with References 1-1, 1-2, and 1-3, describes the principal causes of deterioration and failure of waterfront structures and facilities and prescribes measures for the maintenance and repair of these installations to retain them in continuous readiness for use by the Fleet and in military marine operations. The scope of the maintenance and repair shall be governed by the present and proposed future use of the structures and facilities, their anticipated life, and the cost of repair as compared to complete rebuilding.

1.1.3 COOPERATION AND COORDINATION.

1.1.3.1 Intraservice Functions. Cooperation and coordination of waterfront maintenance activities among

the installation departments concerned should be continuous. Programs of properly planned and executed maintenance operations prevent undesirable interruptions of production on military installations. Measures for the protection of supplies in storage must be coordinated with the storage service primarily responsible for the care and preservation of stored items. Supply officers, through normal channels, provide standard items of materials and equipment for waterfront maintenance.

1.1.3.2 Interservice and Interdepartmental Functions. Cooperation and coordination in conducting waterfront maintenance are encouraged at all levels of command. Appropriate liaison should be established and maintained between major commands and installations in a geographical area. Cross-service assistance shall be provided as necessary in the interests of economy and maximum utilization of manpower and equipment.

SECTION 2. JOINT SERVICE RESPONSIBILITY

1.2.1 ARMY. Staff, command, and technical responsibility for maintenance and repair of waterfront structures at Army installations will conform to assignments set forth in AR 420-10 [1-4].

Requests for assistance should be forwarded through channels to the Director of Facilities Engineering, DAEN-FEZ, Office, Chief of Engineers, Forrestal Building, Washington, D.C. 20314.

1.2.2 NAVY.

1.2.2.1 Naval Facilities Engineering Command. The Naval Facilities Engineering Command is responsible for the provision of services to the operating forces of the Navy in regard to shore facilities and related engineering material and equipment. This Command provides technical support, advice, and assistance regarding maintenance of grounds, buildings, and structures and related services. This authority is delegated to the Commanders and Commanding Officers of NAVFAC's Engineering Field Divisions (EFDs) who provide overall technical guidance in operations and maintenance matters to these shore installations.

1.2.2.2 Commanding Officer. The Commanding Officer at each Naval shore installation is responsible for providing an adequate maintenance program. These responsibilities are usually delegated to the Public Works Centers or Public Works Departments, as appropriate.

1.2.2.3 Public Works Center/Public Works Department. At each Naval and Marine Corps Installation, the Commanding Officer of a Public Works Center or the Public Works Officer is responsible to the activity Commanding Officer for the provision of:

(1) Inspections and surveys to determine and identify defective conditions (NAVFAC MO-322 [1-5] sets up guidelines for inspection. It includes guides, check-off forms, reports, and record systems to be used in the program.)

(2) Recommendations for maintenance standards and procedures that affect industrial production or military operations.

(3) Dynamic Equipment Inspection/ Service (preventive maintenance) programs

(4) Trained and qualified personnel to accomplish effective maintenance

(5) Periodic supervisory personnel training, education, and certification in maintenance programs that utilize work improvement maintenance techniques.

(6) Inspections and instructions to assure that labor, materials, and equipment are used properly and safely in accordance with pertinent regulations, and that operations are planned and supervised by qualified personnel.

(7) Coordination with civilian and other governmental agencies that have similar maintenance capabilities.

1.2.2.4 Engineering Field Divisions. Design and assistance for maintenance and repair are available at NAVFAC's Engineering Field Divisions. They also have special expertise and responsibilities for wood preservation. They can provide the latest available information on specifications and procedures for wood preservatives and treatments.

1.2.3 AIR FORCE.

1.2.3.1 Directives. Policy and standards for the maintenance, repair, and minor construction of waterfront structures are set forth in Air Force Manuals 85-1 and 86-1 [1-6, 1-7].

1.2.3.2 Major Command Level. Design and assistance for maintenance and repair are available at each Major Command. Each major command will:

(1) Insure that effective preventive and corrective maintenance measures are established and accomplished at all installations under its jurisdiction.

(2) Provide qualified technical supervision for personnel engaged in these operations.

(3) Provide for training of personnel engaged in maintenance.

(4) Make certain that base civil engineer personnel engaged in direct field supervision of maintenance operations, or those who function independently of direct supervision, are technically competent and thoroughly familiar with the performance of all phases of this activity, as outlined in this

publication.

1.2.3.3 Air Force Installations. The Base Civil Engineer will:

(1) Plan, initiate, and supervise the execution of maintenance.

(2) Insure that in-house maintenance personnel are trained.

(3) Investigate the occurrence of and reasons for failures and accidents.

(4) Inspect and determine the effectiveness of safety measures.

SECTION 3. MAINTENANCE STANDARDS, POLICIES, AND CRITERIA

1.3.1 STANDARDS. The standards or criteria contained in this manual have been developed by the Army, Navy, and Air Force with the concurrence and approval of the Assistant Secretary of Defense (I&L). Compliance with these standards is mandatory in order that the maintenance of waterfront facilities at military installations will be uniform, will adequately support the operational missions of the installations, and will permit interservice assistance and support, where possible, in the interest of efficiency and economy.

1.3.2 ENGINEERING. The need and accomplishment of major repairs and rehabilitation of existing waterfront facilities will be based on experience, judgment, and/or engineering evaluation. When waterfront structures are in an inactive status, the maintenance policies will be consistent with the anticipated future mission of the installation and in accordance with the inactivation plan.

The services of qualified technical personnel will be used to assist in the establishment of waterfront maintenance programs. A glossary of waterfront terms is provided in the back of this manual.

1.3.3 RELATED PUBLISHED MATERIAL.

Requirements for the design and construction of waterfront facilities are found in References 1-2, 1-3, and 1-8 through 1-13. References 1-14 and 1-15 are manuals prepared by the American Association of Port Authorities on port design and construction and on port maintenance, respectively. Reference 1-16 is especially important relative to inspection of waterfront structures. Reference to other published materials, which provide related or more extensive information on specific areas of waterfront maintenance, is made where appropriate throughout this manual and its Appendixes.

SECTION 4. TERMINOLOGY

1.4.1 PRIMARY CONSIDERATIONS. The upkeep of waterfront structures and other harbor facilities falls into the following areas of consideration: (1) Inspection, (2) Maintenance, (3) Repair and Reconstruction, and (4) Control of Marine Organisms.

1.4.1.1 Inspection. Inspection is the act of checking, visually and mechanically, the condition of facilities. This inspection should be performed on a routine basis, as indicated in this manual. The evaluation of the inspections will determine the degree of hazard involved with each structure. This degree of hazard will be used to determine the priority sequence of repair and the extent of repair required.

1.4.1.2 Maintenance. Maintenance is the recurrent day-to-day, periodic, or scheduled work that is required to preserve or restore a facility to such a condition that it can be effectively utilized for its designed purpose. It includes work undertaken to prevent damage to or deterioration of a facility that otherwise would be more costly to restore. Drainage is the single most important maintenance procedure. Water on, in, below, above, or anywhere near a structure creates special maintenance problems.

1.4.1.3 Repair and Reconstruction. Repair is the restoration of a facility to such a condition that it can be effectively utilized for its designed purpose. The repair is accomplished by overhaul, reprocessing, or replacement of constituent parts or materials that have deteriorated by action of the elements or usage and have not been corrected through maintenance. Repair can be incorporated in a concurrent modernization program.

1.4.1.4 Control of Marine Organisms. This control begins with the use of materials resistant to marine organisms when waterfront structures and other harbor facilities are designed and constructed. The control is a continuing requirement involving the taking of all known corrective measures and providing effective countermeasures to inhibit the growth of destructive organisms in waterfront facilities.

1.4.2 TYPES OF STRUCTURES. Waterfront facilities are structures and facilities that provide service for:

- (1) Transferring ordnance, other cargo, and passengers
- (2) Refueling ships
- (3) Storing goods
- (4) Supplying utilities to home-based vessels
- (5) Berthing, constructing, overhauling, and repairing ships
- (6) Conducting military marine operations
- (7) Protecting the shoreline

1.4.2.1 Pier. A pier (Figure 1-1) is a deck structure supported above the water on piles (open type), a solid-fill structure retained by bulkheads (closed type with apron), or a combination of the two. It extends outward from the shore into a harbor or other navigable waters to permit berthing along one or both sides of its length.

1.4.2.2 Wharf. A wharf or quay (Figure 1-2) is a deck structure supported above the water on piles (open type),

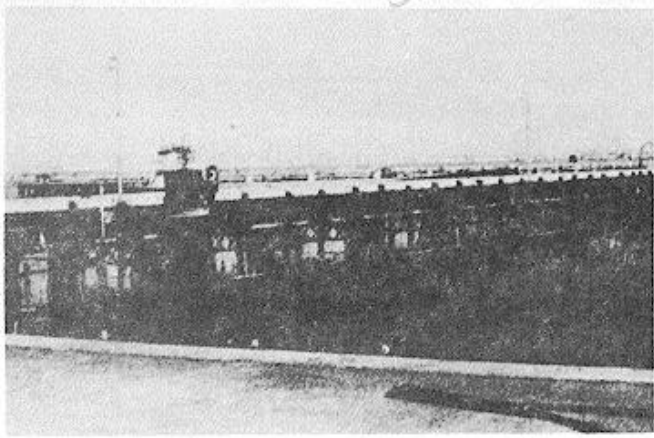

Figure 1-1. Open-type pier.

a solid-fill structure retained by bulkheads (closed), or a combination of the two. It runs parallel to the shore and is connected to it at more than one point (usually continuously) to provide berthing normally along one side.

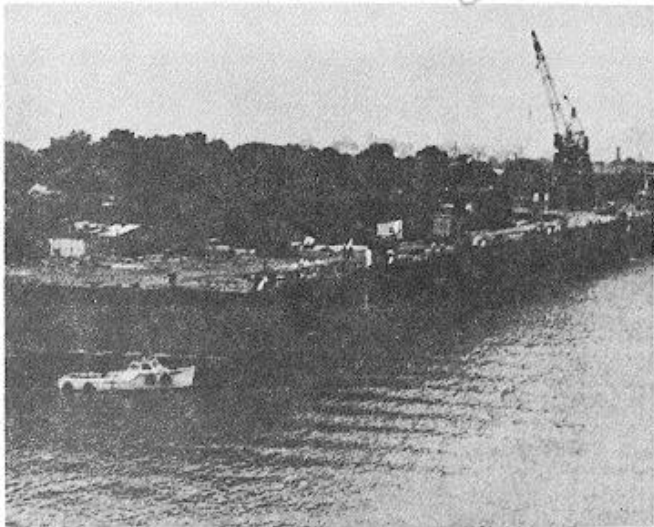

Figure 1-2. Example of a wharf.

1.4.2.3 Dolphin. A dolphin (Figure 1-3) is a structure usually consisting of one or a group of piles. It is placed near piers and wharves or in turning basins and ship channels (1) to guide vessels into their moorings, (2) to fend vessels away from structures, shoals, or the shore, (3) to support navigation aids, or (4) to moor a vessel.

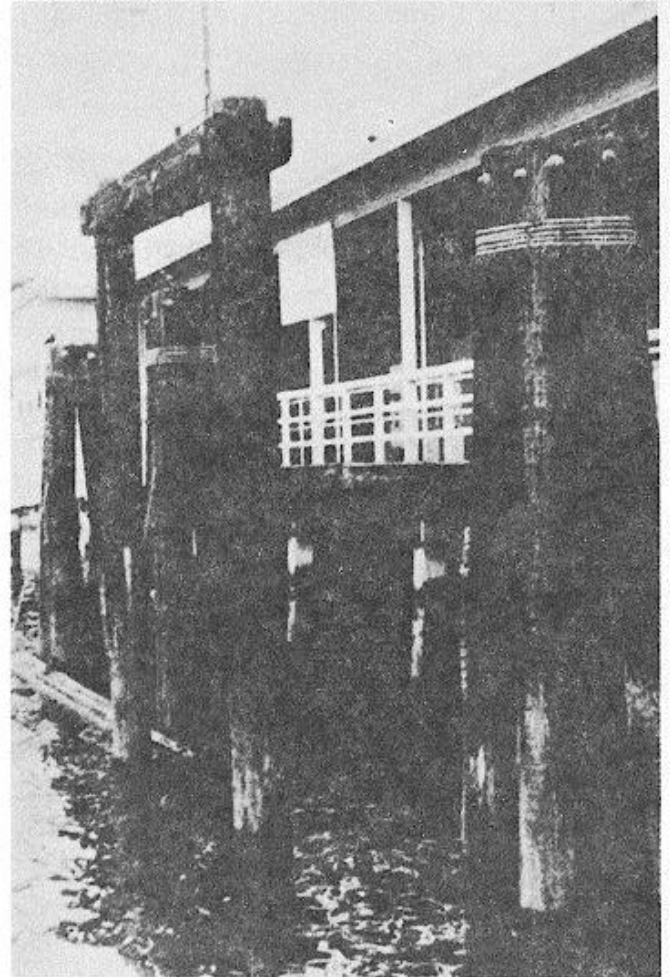

Figure 1-3. Example of a dolphin.

1.4.2.4 Fleet Mooring. A fleet mooring is an offshore ship anchoring system that consists of a ground tackle arrangement of chain or cable, sinkers, and anchors or other holding devices placed on the bottom of an anchorage. It is connected by means of a riser chain (or chains) to a buoy (riding on the surface of the water) whereby a ship can be made fast to the buoy. Maintenance of fleet moorings is described in Reference 1-17; it is mentioned in this manual only to identify fleet moorings as an important type of waterfront structure requiring regular maintenance.

1.4.2.5 Drydocking System. A drydocking system is a facility for exposing the normally underwater portion of a ship for construction, inspection, modification, repair, or

hull maintenance. Several different types are listed below.

1.4.2.5.1 Graving Dock. A graving dock (Figure 1-4) is a fixed basin usually of stone masonry, concrete, or piling cells adjacent to the water's edge. It can be closed off from the waterway by a movable watertight barrier (entrance caisson or flap gate). It can, therefore, be pumped dry, allowing a ship to settle down on blocking set on the dock floor.

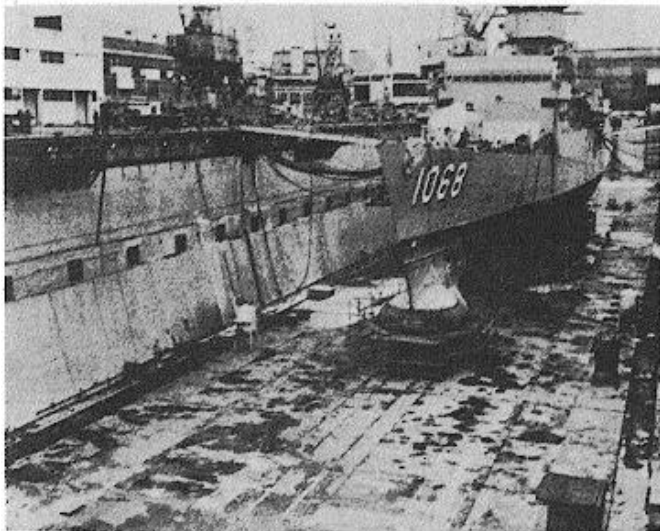

Figure 1-4. Graving dock with ship installed.

1.4.2.5.2 Floating Drydock. A floating drydock is a ship or U-shaped structure that can be submerged by flooding to permit a vessel to enter and then later be pumped dry to raise the vessel out of the water. Maintenance and operation of floating drydocks will not be discussed in this manual.

1.4.2.5.3 Marine Railway. A marine railway (Figure 1-5) consists of an inclined groundway extending into the water, a mobile ship cradle on wheels or rollers, groundway ship cradle tracks, hoisting machinery, and chains or cables for hauling the ship cradle endwise or sidewise.

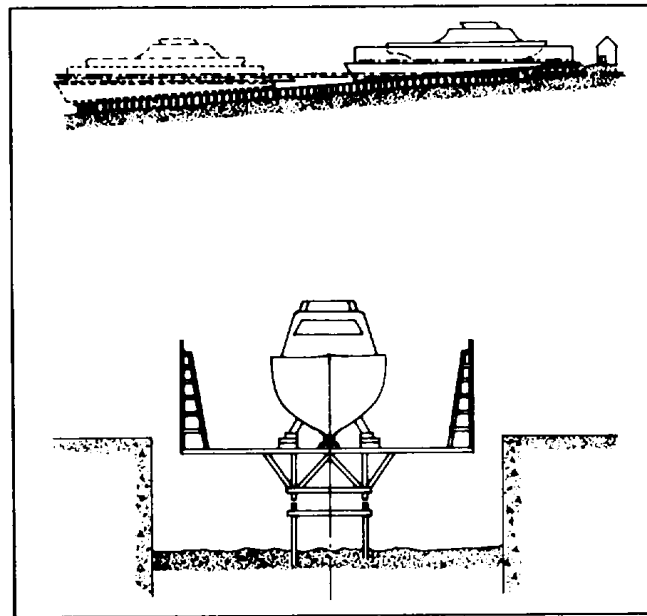

Figure 1-5. Example of a marine railway.

1.4.2.5.4 Vertical Lift. A vertical lift drydock (Figure 1-6) is a platform which is lowered into the water to receive a ship, and then elevated out of the water by electrically, pneumatically, or hydraulically powered hoisting equipment.

1.4.2.6 Quay Wall. A quay wall (Figure 1-7) is a barrier of steel, stone, concrete, or wood that supports an embankment or fill built as a part of a waterfront structure.

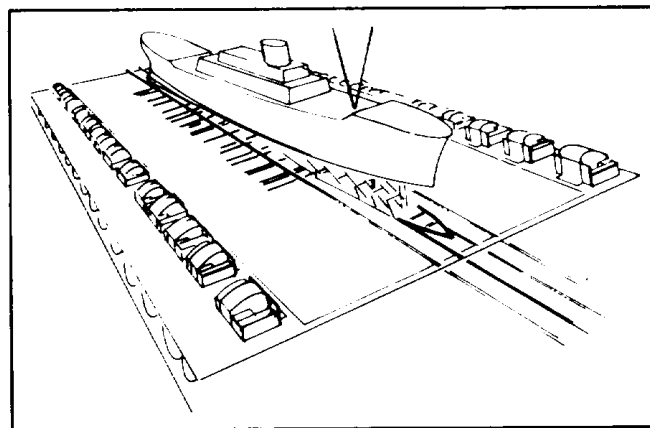

Figure 1-6. Example of a vertical lift drydock.

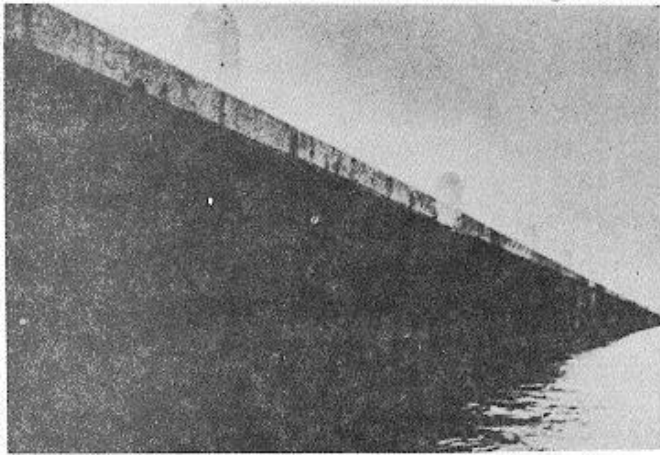

Figure 1-7. A quaywall.

1.4.2.7 Mole. Moles are normally earthen structures that extend outward from shore into the navigable waters of the harbor (Figure 1-8). The sides and offshore end of a mole are retained or protected by riprap, sheet-pile bulkhead of either prestressed or reinforced concrete, or a gravity-type wall of either masonry or concrete. Such a structure is sometimes used as a breakwater. Generally, the level top is appreciable in area and may contain paved roads, railroads, and crane trackage. If the sides and offshore end of a mole are protected by either a bulkhead or a gravity-type wall, the structure can be used to berth vessels, provided the depth of water is adequate.

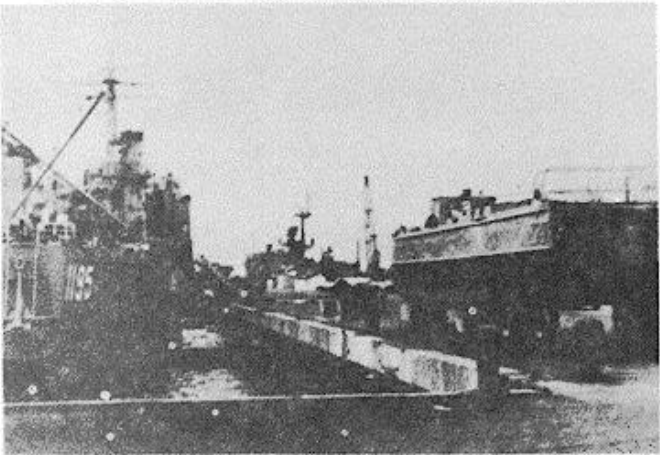

Figure 1-8. Example of a mole.

1.4.2.8 Jetty. These structures, which are located at the entrance to a harbor or in a river estuary, extend from the shore into deeper water to prevent the formation of sandbars and to direct and confine the flow of water due to currents and tides (Figure 1-9). Jetties are usually constructed of mounds of large rubble to an elevation several feet above high tide. They are generally lower in height than breakwaters and are designed to offer less resistance to waves than breakwaters and seawalls. Jetties should be dense enough to prevent sand from entering the entrance channel.

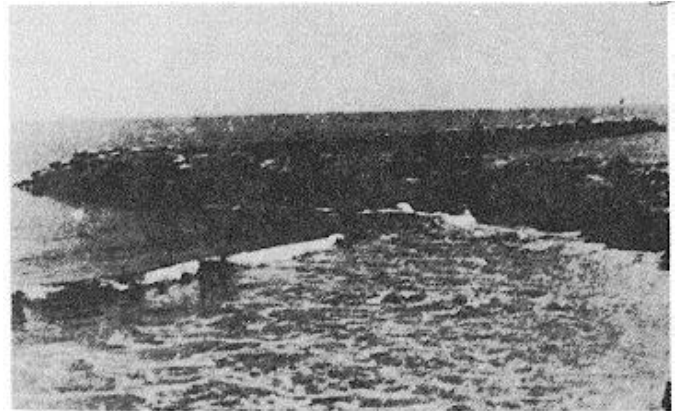

Figure 1-9. Example of a jetty.

1.4.2.9 Breakwater. These are substantial structures, located at the outer limits of a harbor or anchorage, to protect the inner waters against the effects of heavy seas and winds and to ensure safe mooring, operating, loading, or unloading of shipping within the harbor (Figure 1-10). These durable barriers usually consist of rubble-mound structures and are often covered with heavy, large rocks or reinforced concrete armor units. There are three general types of breakwaters, depending on type of exposed face: (1) vertical, (2) partly vertical and partly inclined, or (3) inclined. Breakwaters may be either detached from the shore or shore-connected.

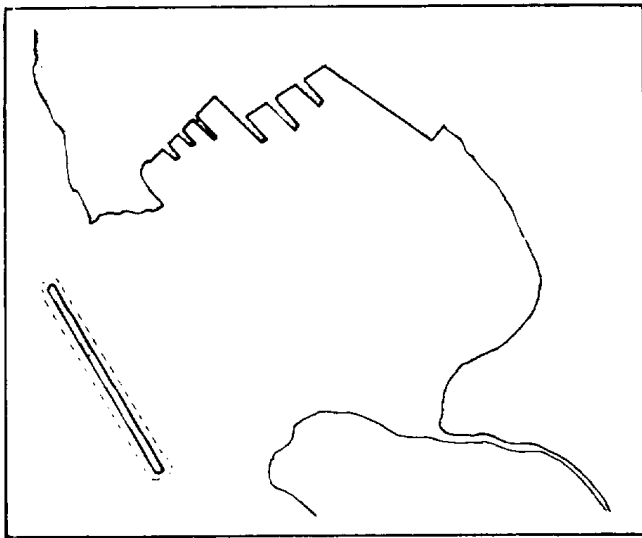

Figure 1-10. Example of the placement of a breakwater.

1.4.2.10. Groin. These structures control the rate of shifting sand by influencing offshore currents and wave action in a manner such that erosion of the shoreline is prevented or minimized (Figure 1-11). Generally, the longtime effect of groins is an increase in the width of the beach. These narrow structures may be perpendicular to the shoreline and are constructed of large rocks (at least 1 ton each), precast concrete units, reinforced or prestressed concrete piles, steel sheet piles, or timber cribbing filled with rock. The most common type of groin is the high, dense one that is designed to catch the drifting sand until the sand is forced around the offshore end.

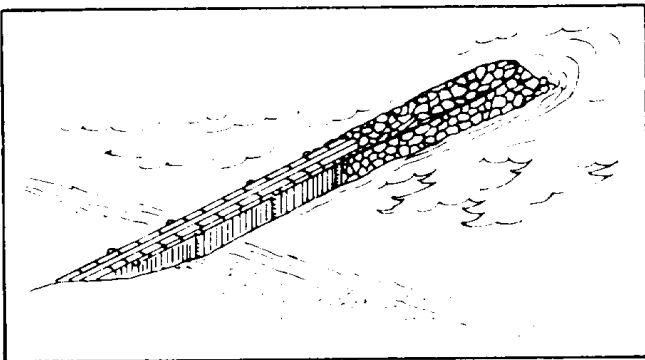

Figure 1-11. A groin.

1.4.2.11 Seawall. These are massive structures, built along and parallel to the shoreline, that are designed to protect coastal areas against erosion caused by wave action and flooding during heavy seas (Figure 1-12). The seawalls are constructed of rubble-mound, granite masonry, or reinforced concrete. They are usually supplemented with steel or concrete sheet pile driven into the beach and strengthened by wales and brace-type piles.

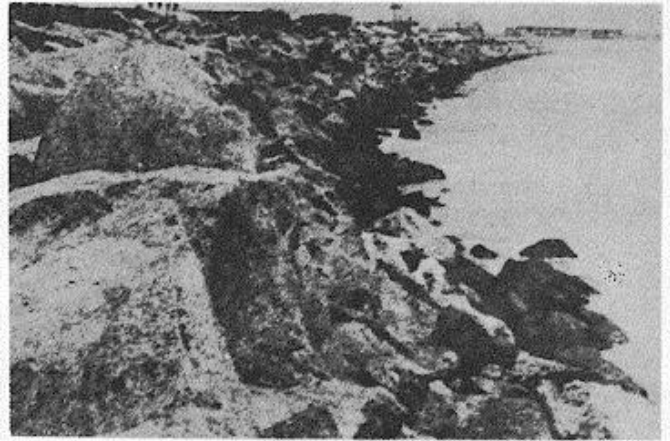

Figure 1-12. Example of a seawall.

SECTION 5.

1.5.1 PROGRAMMING. The maintenance program for waterfront structures and other harbor facilities shall be developed to include the prevention and prompt detection of deficiencies or damage and the quick performance of maintenance or repairs in an economical and workable manner. Replacement or repair of damaged parts should be made as soon as possible because when one item is not working, the remaining parts are more easily damaged. These requirements are essential to the maintenance standards established by higher authority.

1.5.2 ECONOMIC REQUIREMENT. In the maintenance of waterfront facilities thorough consideration shall be given to the overall economy of the facility. Of particular importance is a complete study of the replacement cost of the facility in relation to the expected life span and the cost of repairs. Other factors to be considered include the following: prompt detection of deficiencies or damage and the expeditious performance of maintenance or repairs in an economical and workable manner. Replacement or repair of damaged components should be made as soon as possible because of:

- (1) Possible obsolescence of the facility
- (2) The present adequacy of the facility
- (3) The present and future availability of maintenance funds
- (4) The operational economics of downtime involved in major repair or replacement of facilities.

1.5.3 CAUSES OF DETERIORATION. The deterioration of waterfront facilities is caused by exposure to destructive forces, such as:

- (1) Attack by fungi, termites, and marine organisms
- (2) Corrosion
- (3) Mechanical damage, including the impact and pressure of ships and cargo and the abrasive action of sand, ice, and debris
- (4) Erosion due to wind and wave action, tides, water currents, rain, snow, sleet and ice, and freezing and thawing.

1.5.4 INSPECTION. Waterfront facilities shall be inspected periodically to determine the extent of the maintenance and repair work required. References 1-1 and 1-16 set up the Navy's guidelines for inspection and include essential information on guides, check-off forms, reports, and record systems to be used in the program. It is recommended that inspections be made annually of all basic structures and more frequently for fenders and movable equipment, such as brows and camels. Additional inspections may be necessary under certain circumstances, such as tidal waves, high tides, earthquakes, typhoons, heavy freezes, etc. Inspections may be made from the structures, from a boat or float, or from below the water line by divers. (See Appendix A for details on diver inspections.) Underwater television is often employed in visual inspections.

SECTION 6. PREPARATION FOR WORK

1.6.1 FIELD MEASUREMENTS. During inspections, wear, corrosion, alignment, deflection, etc. may be estimated. Where there is any question as to the degree of hazard, an accurate engineering investigation shall be made. Facilities to be repaired shall be carefully measured so that construction details can be designed and estimates of required materials prepared. Material storage areas should be designated and laid out at this time so that interference with traffic is minimized. Field measurements should include the exact location of underground utilities so that they can be avoided or relocated as necessary.

1.6.2 AS-BUILT DRAWINGS. "As-built" drawings, if available, should be used in programming the repairs rather than the original drawings, because these drawings should show all deviations from the original design and changes made during the original construction. These drawings should be carefully compared with actual field observations to detect any changes that might have been made after completion of the as-built drawings.

1.6.3 SKETCHES. As a part of programming the repairs, sketches should be made to outline clearly the extent, sequence, and details of the repair operation. On other than major projects, freehand sketches, properly dimensioned and supplemented by notes, will be sufficient to permit an experienced maintenance man to carry out the work properly. All sketches should be clear and legible and should normally be reproducible. Copies of the sketches, properly identified as to location and date, should be filed with the job record and with the as-built drawings.

1.6.4 CHECKING STRUCTURAL STABILITY. Any evidence of damage or deterioration affecting the structural stability of any facility should be the subject of an immediate engineering study. This study should include the degree of hazard and recommendations as to what corrective measures are required.

SECTION 7. ACCESS TO WORK

1.7.1 DIVERS. No one skill is more essential to the proper performance of maintenance and repair work on waterfront structures than that of the diver. The diver, in addition to being certified, should be experienced in construction and familiar with construction tools and materials. The diver must also be able to report clearly and in exact detail underwater conditions (see Appendix A).

1.7.2 RAFTS AND/OR BARGES. Rafts or barges for general repair work should have a flat, open-deck area completely covered with planking that is reasonably tight to prevent both accidents to workmen and the loss of tools and equipment. The rafts can be supported on logs or pontoons. The structures should be rigid enough to withstand considerable shock. The raft should be equipped with well-secured cleats or other means for

securing lines. Rafts should be fitted with handrails or lifelines on the sides that are not adjacent to the work. Deck planking should be kept in repair by plugging any holes and replacing broken or cracked planks. Rafts with steel pontoons and framework should be kept painted to prevent deterioration and should have adequate fendering systems.

1.7.3 SCAFFOLDS. All scaffolding shall conform to all military and ASSHO safety regulations.

1.7.3.1 Wood Scaffolds. Wood scaffolds should be built to suit the particular work that is to be done from them. They should be rigid and completely stable in themselves, even when not secured to a structure. No less than two 10-inch-wide planks of 2-inch nominal thickness should be used as the platform. The unsupported span shall not exceed 10 feet. All planks used for scaffold platforms should be tested immediately prior to the installation of the framework. If no other means of testing is available, each plank should be placed flat and supported at each end by a block 12 inches high. The plank should then be loaded at its midpoint with twice the anticipated load on the scaffold, and the load left on for at least 5 minutes. If visible or audible failure occurs, or if the plank remains deformed after the load is removed, it should be discarded. All scaffold planks should be free of large knots, shakes, splits, checks, or any other visible defects. All scaffold planks should be securely fastened. Any scaffold plank that, by use or accident, becomes broken, cracked, warped, or in any way defective should be replaced immediately by a sound plank.

The strength of the scaffold framework should be more than sufficient for the height of the scaffold. No

posts less than 4 inches by 4 inches should be used for a scaffold, and they should be securely cross-braced. Convenient access from the ground and from one level to another should be provided by ladders or stairs that are rigidly secured. All platform levels should have well-supported life rails. On the land side, supports must be placed on firm ground, preferably in such a manner that they can be wedged up or raised if necessary. If vehicles will pass adjacent to or near the scaffolding, substantial barricades should be placed at least 3 feet from the supports of the scaffold.

Fire extinguishers of adequate size shall be stationed near wood scaffolds to conform with fire regulations.

1.7.3.2 Pipe Scaffolds. Pipe scaffolds should be free of any bent, dented, or otherwise defective members. Every connector of each tier must be made tight before the next tier is installed. Joints and connectors in pipe scaffolds must be tightly bolted. Scaffold supports should be maintained in a vertical position.

1.7.3.3 Hung Scaffolds. Platform planking and life rails for hung scaffolds should be similar to those for built-up scaffolds. The rope or line used should be of more than ample size and free of defects; it should be secured to cleats, bits, a string piece, or another substantial part of the structure. The scaffolds should also be equipped with a positive mechanical or structural means of belaying the free end of the rope or line.

1.7.4 LADDERS. All ladders should be made with sound, secure rungs notched into, or passing through,

the stringers. Broken or cracked rungs should be replaced immediately. Ladders should not be painted because this could conceal defects.

Wooden ladders shall be treated occasionally with clear linseed oil to prevent the wood from drying out. New ladders, especially those with hardwood rungs, should be dipped in a 5% pentachlorophenol solution for 3 minutes to deter rotting. If dipping is not possible, the solution should be brushed or sprayed on. Linseed oil need not be applied when the latter treatment has been used.

1.7.5 EXCAVATIONS. Excavations for repair work are normally required for access to underground parts of a structure. The safety of the structure during excavation is of prime consideration. The excavation should be made so that the surrounding ground does not lose its own stability or such support as it may be giving to the adjacent structure. This is accomplished by:

(1) Removing material in a manner so that a stable, sloping bank is created around the sides of the excavation.

(2) Driving vertical wood, concrete, or steel sheeting around the sides of the area to be excavated,

and re-driving the sheeting further as excavation progresses

(3) Installing breast boards around the sides of the excavation as it progresses downward.

(4) Driving soldier beams and placing breast boards between them as the excavation progresses.

Where excavations are necessary beneath the water table, it may be necessary to dewater the site to permit working in the dry. In such instances the major criteria to meet are those dealing with loss of stability of the bottom or sides of the excavation and removal of the water (see References 1-18 through 1-20).

In some cases it may be necessary to stabilize the soil prior to excavation by using, for example, electroosmosis for fine-grained soils, or freezing or grouting to stabilize the coarser soils (see Reference 1-18).

Necessary measures should be taken and careful observations made to be sure mud, silt, water slurry, and other excavation materials do not undermine adjacent roads, piers, fills, tracks, and facilities.

SECTION 8. SAFETY

1.8.1 INSTRUCTIONS. Safety precautions and safe maintenance practices are covered in detail in the following:

- (1) Army EM 385-1-1 [1-21]
- (2) Navy NAVFAC 5100.1 1 A [1-22]
- (3) Air Force AFM 127-101 [1-23]

1.8.2 PERSONAL PROTECTION. Workmen in hazardous locations should wear life belts or safety belts (or both) attached to safety 1 lines according to the

conditions at the site of the work and ASSHO regulations. Safety lines should be rigged with as little slack as possible. If the slack is more than two or three feet, a workman could be injured by even this short fall. Always use a safety belt, never a loop of rope around a man's body. Insist on workmen using hard hats, unless they are clearly unnecessary, and require them to wear safety glasses when chipping, grinding, or sandblasting. Safety shoes and other types of protective clothing are

frequently necessary and should be used. A respirator should be available for use should the need arise.

1.8.3 BARRICADES AND SAFETY LINES. All unsafe traffic areas, such as openings, interruptions, or breaks in deckings, roadways, or walkways, should be completely surrounded by adequate barricades. The barricades should be set sufficiently far back from the edge of the opening so that no person or vehicle can fall into the opening. The barricades should display plain, legible signs and lights to warn of the danger. If work of a particularly hazardous nature is being done on a deck, on the ground surface, or on an overhead structure or bulkhead, the affected area should be barricaded until it is again safe for traffic to proceed. Welding at or near the vehicular or pedestrian traffic area should be completely surrounded by a solid shield high enough to prevent direct view of the flame or arc.

1.8.4 TRAFFIC CONTROL. Traffic (both land and water) in and out and around of a waterfront area is of prime importance. Maintenance or repair operations should be organized in such a manner as to minimize traffic (including cranes) inconvenience. If it is necessary that a repair operation restrict traffic, the operations should be planned and the required barricades so constructed that, in case of an emergency, operations can be stopped and barricades removed in a reasonably short time. If repairs undertaken as a whole will restrict traffic, the repairs should be done in parts, if possible, so as to offer the least hindrance to traffic and base operation.

1.8.5 PROTECTION FROM MECHANICAL DAMAGE. All waterfront structures should be protected from mechanical damage, such as impact from ships and floating debris, insofar as practicable. Fenders are

normally provided in berthing areas to cushion the impact of ships when docking. In some cases, it may be economical to provide dolphins for additional protection to waterfront structures. All special problems of protection of waterfront structures should be referred to design personnel of the activity or the appropriate Engineering Office.

1.8.6 BERTHING. Anchoring or mooring of ships or work barges must vary with the nature of the work and take into account the rise and fall of the tide, currents, wind, waves, and traffic. The lines must be so placed that they will not be fouled by traffic using regular channels. Proper signals and lights must be displayed on craft anchored in a channel or turning basin. The berthing system should have sufficient reserve to allow for a sudden change to bad weather. All lines should be secured in such a manner that they are easily accessible and can be quickly let out or hauled in. Rafts tied alongside a structure should have fenders to prevent damage to the structure or raft. If weather predictions are such that damage to the raft or structure could happen, additional anchors or lines should be put out or the raft moved to a sheltered area.

1.8.7 CURRENTS. All supervisors of the repair force should be thoroughly familiar with currents in the river, harbor, or seafront on which a repair site is located. The velocity and direction of currents can change with varying conditions of tide, wind, and rainfall. Changes in the direction of the wind can alter currents by raising or lowering the water level along the sea front. Anchored or berthed vessels, if in a comparatively small or narrow

waterway, can also alter the current. A chart showing direction and velocity of currents in the area should be available at every repair site.

1.8.8 CHANGES IN TIDES. Tidal changes at waterfronts are usually regular and predictable unless they are affected by wind, which can alter the range of the tide considerably. The greatest variations take place in the tidal waters of a river where the river outflow to the sea is through a widening estuary. A chart should be available at the repair site that shows the range of tides and notes conditions anticipated with various wind velocities.

CHAPTER 2 - TIMBER STRUCTURES

SECTION 1. PRESERVATION OF WOOD

2.1.1 PRESERVATIVE TREATMENT. Timber structures in a marine environment are subject to attack by a variety of destructive organisms. Thus, they should be properly treated with appropriate preservatives to prevent or retard this type of deterioration.

2.1.2 WOOD DESTROYING ORGANISMS. Of the many types of wood destroying organisms, this manual will mention only those that are responsible for the greatest amount of damage to waterfront structures. These organisms are fungi, marine borers, and termites.

2.1.2.1 Fungi. Briefly, fungi are low forms of plant life that contain no chlorophyll and, thus, must depend on organic materials for food (see References 2-1 and 2-2). They are divided into four groups according to the type of damage they cause: (1) molds, (2) sap stain fungi, (3) decay fungi, and (4) soft-rot fungi.

Mold damage is generally restricted to the surface of materials and can be removed by brushing or planing. However, its presence indicates that conditions are favorable for the development of decay bacteria.

Sap stain fungi produce sapwood discolorations that range from brownish or steel gray to blue and black. They penetrate deeply into the wood, and although they do not affect most strength properties, they can sharply reduce the shock resistance of wood.

The two major types of decay fungi produce two kinds of decay: brown rot (often called "dry rot") and white rot. Brown rot causes wood to shrink, collapse, and crack across the grain (Figure 2-1). White rot does not crack the wood across the grain, nor does the wood shrink or collapse until severe degradation has occurred.

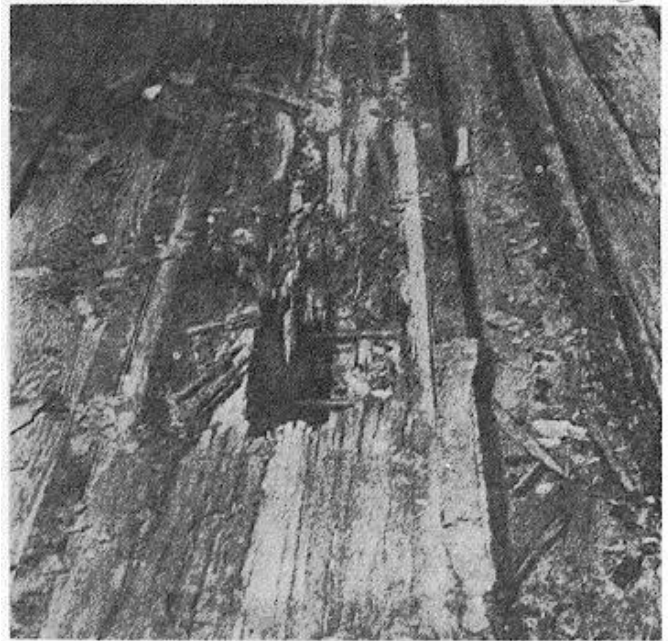

Figure 2-1. Example of brown rot.

Soft rot fungi can tolerate wetter and drier conditions than the more familiar decay fungi. Their depth of attachment is shallower, and the change from decayed area to undamaged area is very abrupt. Soft rot fungi are responsible for the surface "weathering" of wood.

Design and construction techniques that provide for quick drainage of wood waterfront structures will contribute much to minimizing damage from rot.

2.1.2.2 Marine Borers. Marine borers are organisms that live in seawater or brackish water and are capable of destroying wood (Figure 2-2). (See Reference 1-1.) There are two general types mollusks and crustaceans.

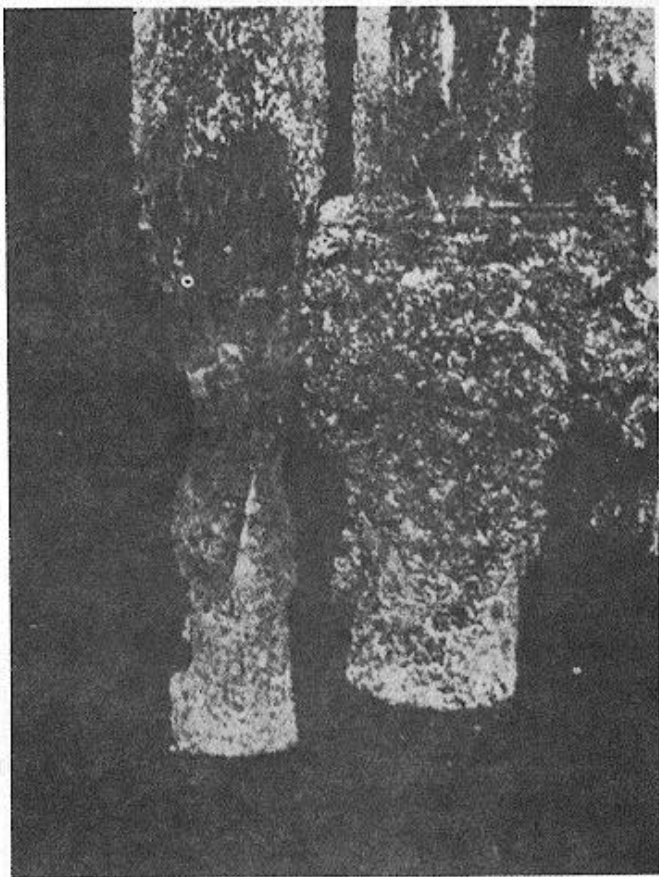

Figure 2-2. Destruction of wooden piers by marine borers.

There are two families of molluskan marine borers - pholads and teredines. Pholads bore into wood, soft rock, or concrete for protection; they are commonly known as rock borers. Their shells, which are

pear-shaped, can reach 2-1/2 inches in length; pholads can withdraw completely into their shells. *Martesia striata*, the species that causes considerable damage to waterfront structures, occurs worldwide between 35 degrees north latitude and 35 degrees south latitude. The presence of these organisms can be determined by visual inspection.

The teredines, *Teredo* and *Bankia*, are commonly referred to as "shipworm" because of their wormlike appearance (Figure 2-3). They enter the wood as larvae less than 1 mm in diameter, change to their adult form, and continue to grow as they lengthen their burrows. Only a pair of almost transparent tubes, called siphons, extend from the entry hole into the water. However, if the water is disturbed or becomes distasteful, the siphons are retracted, and the hole is blocked with a structure called a pallet. Because of this, the presence of teredines is most difficult to detect.

Of the three common crustacean wood borers *Limnoria*, *Sphaeroma*, and *Chelura* only *Limnoria* is considered to be economically important. *Limnoria*, commonly called gribble, is a small (3 to 6 mm long) animal with a segmented body and seven pairs of legs. It burrows at or just below the surface of the wood to form a network of tunnels or grooves. The three most economically important species are *Limnoria lignorum*, *Limnoria tripunctata*, and *Limnoria quadripunctata*. Of these, *Limnoria tripunctata* is considered the most important because it can attack creosoted wood (Figure 2-4).

2.1.3 PRESERVATIVE MATERIALS. The American Wood Preservers' Association (AWPA) classifies wood preservatives into three types: creosote and creosote solutions, oil-borne preservatives, and water-borne preservatives. Both AWPA standards and Federal specifications for wood preservations are subject to change, so in each case the latest standards and/or specifications should be used.

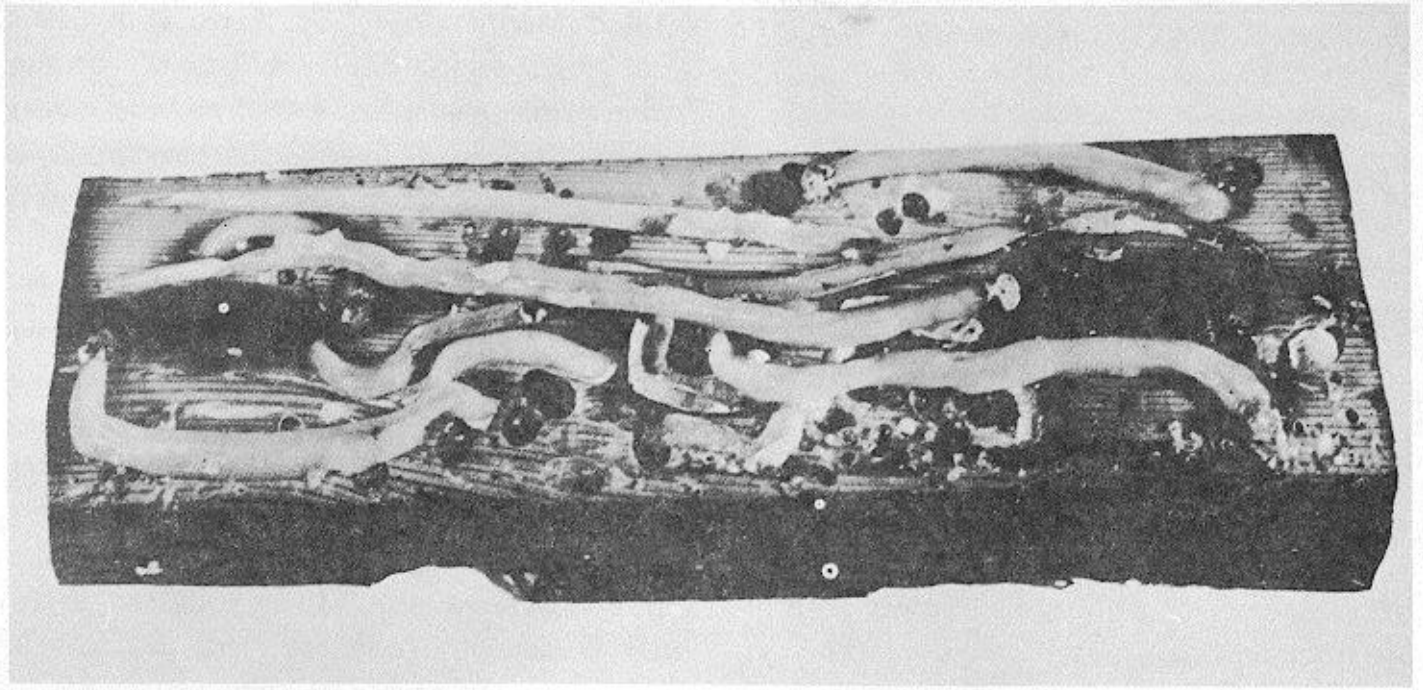

Figure 2-3. *Bankia* (shipworm) infestation of wood planking.



Figure 2-4. Surface of creosoted piling infested with *Limnoria*. Inset shows the three types of *Limnoria*.

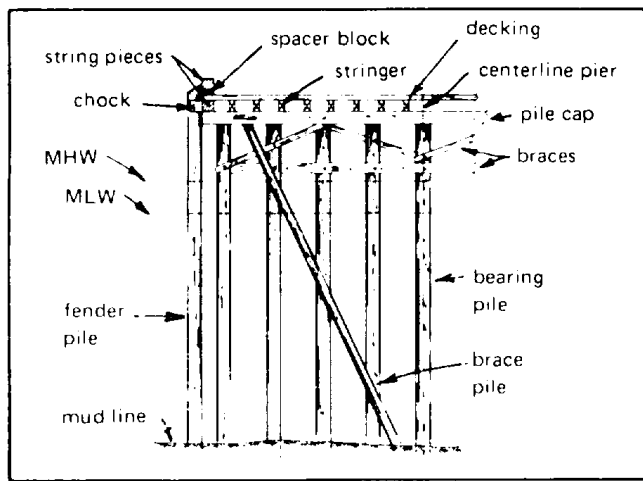

Figure 2-5. Pier components.

2.1.4 PRESSURE TREATMENT. All timber products (Figure 2-5) used in a marine environment should be pressure treated with an appropriate preservative. The choice of preservative depends on how the timber product is to be used (pile, cap, stringer, decking, etc.) and what kind of climate exists where the installation is to be made (cold, temperate, semitropical, tropical). Thus, the requirements are greatest in warm water harbors where *Limnoria tripunctata* and pholads are present. Pacific Coast Douglas fir has less sapwood than Southern pine so that retention measurement of preservative is generally made in the outer 2 inches for fir as compared to the outer 3 inches for pine. The AWPA standards and Federal specifications for treatment indicate the required retention level of the various wood preservatives.

2.1.4.1 Piles. Wood piling should be treated according to their particular purposes (e.g., cold water marine,

warm water marine, freshwater) as specified by AWPA standards or Federal specifications.

2.1.4.2 Marine Pile Top Caps (Cut-Offs). After installation, piles are cut off at the desired final elevation; therefore, the newly exposed surface mainly the heartwood must be treated with a preservative. Swabbing the cut-off with hot creosote provides no preservation for the exposed heartwood. The preferred method is to drill a series of evenly spaced 3/4-inch-diameter holes about 1-1/2 inches deep in the untreated area. These holes are filled with creosote, and then a cover made from lead sheet is applied. As an alternative, an iron ring can be driven into the pile top or clamped around the piles so as to extend above the pile top. Hot creosote is poured into the ring and allowed to soak into the untreated area. Then the ring is removed, and a cover of soft, corrosion resistant metal (copper, high copper alloy, or zinc) or a tarimpregnated fabric is fastened into place. The metal top caps have a longer service life than the fabric ones.

2.1.4.3 Marine Pile Caps and Braces. Pile caps and braces can be periodically submerged by high tides, although waterfront structure design should be such that this situation is avoided. If submergence cannot be avoided, then those members involved should be treated in the same way as piles. Timbers that are difficult to treat should be incised before treatment. The life of submerged braces can be extended 20 to 25 years by wrapping them with a poly(vinyl chloride) (PVC) sheet. A simple modification of the method used for protecting wood piles from attack by marine borers is followed.

2.1.4.4 Freshwater Pile Top Caps (Cut-Offs). These should be treated in the same manner as marine pile top caps.

2.1.4.5 Freshwater Pile Caps and Braces. These should be treated the same way as freshwater piles. However, those woods that are difficult to treat should be incised before treating.

2.1.4.6 Stringers (Marine and Freshwater Environments). Stringers should be treated with creosote, creosote-coal tar solution, creosote-petroleum solution, pentachlorophenol solution, or inorganic salts.

2.1.4.7 Spacer Blocks (Marine and Freshwater Environments). Spacer blocks, which are installed between piles and braces to correct for misalignment, should be pressure-treated in the same manner as the piles and braces. They should be treated after all cutting and drilling has been done, or the untreated wood will be exposed to marine borers and decay.

2.1.4.8 String Pieces. The string piece is sometimes referred to as the curb, bullrail, or backing log. Because of its exposed position, it is subject to much wear and to constant wetting and drying. Therefore, it should be treated with the same preservatives and to the same retention as decking. Because string pieces are large timbers, they should be incised before treating. Cut-off surfaces should be treated with a gelled or grease-type preservative.

2.1.4.9 Chocks. Chocks, which serve as bracing between piles, should be treated in the same manner as string pieces.

2.1.4.10 Decking. Wear from traffic is often stated as the cause for deck failure; however, surface decay is a frequent cause. Decking should be treated with an appropriate preservative. Creosote, creosote-coal tar solutions, or creosote-petroleum solutions are effective

preservatives, but present a possible contamination problem from being tracked onto vessels. Salt treatments are effective, but may embrittle or promote accelerated wear of the deck surface. Solutions of pentachlorophenol in oil are effective, but they also may cause a pollution problem. Treatment with pentachlorophenol in liquefied petroleum gas should provide protection without the contamination problems, especially if a clean surface is specified in the procurement.

2.1.4.11 Fire Curtain Walls. Substructure fire walls or fire stops can be made of wood planking built up to a thickness of 6 inches and fastened to the bearing piles (Figure 2-6). Because these walls extend to the low water line, they should be treated with the same preservative systems as the piles. Also, each side of the wall should be protected by automatic sprinklers or by nearby openings in the deck through which revolving nozzles or other devices can be used to form an effective water curtain [2-3].

2.1.5 HANDLING OF TREATED WOOD. Treated wood components should not be handled with pointed tools or dropped so that their surfaces are crushed, gouged, or chipped. Those areas of treated piles that will be submerged in seawater should not be notched, dapped, or counterbored for bolt heads or nuts. Those areas of treated piles that will always be above water can be notched or dapped, but all surfaces exposed by these operations must be treated with an appropriate preservative specified by AWPA standards or Federal specifications. All bolt holes should be treated with a preservative containing a bolt hole treater (no longer

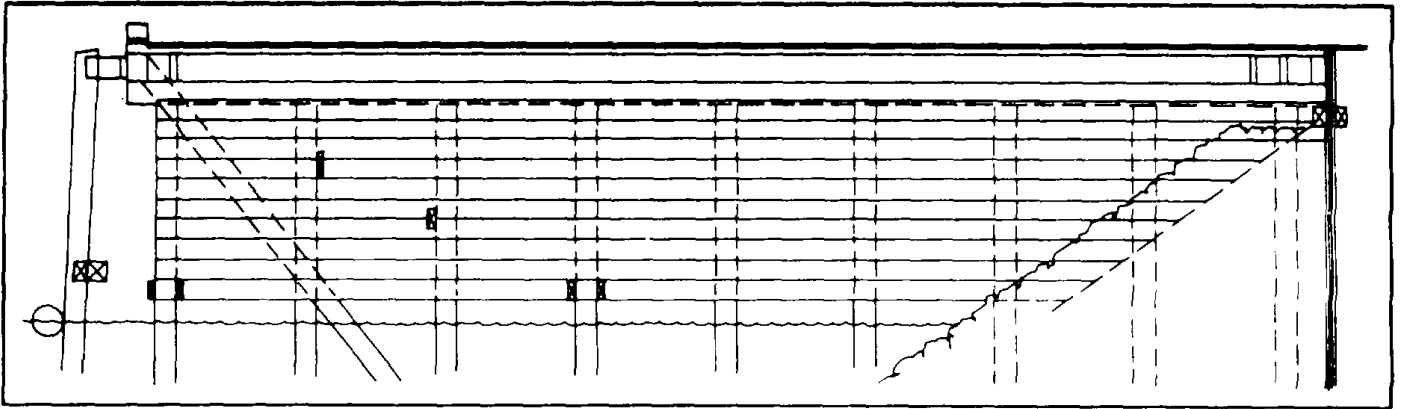

Figure 2-6. Fire-curtain wall.

manufactured) if one is available. Otherwise, a funnel with a bent stem can be used to pour preservative into the bolt hole. Any hole that is drilled, but then for some reason is not used, should be treated with the appropriate preservative and then stoppered by driving in treated plugs.

2.1.6 SEASONING CHECKS OR CRACKS. Seasoning checks or cracks often develop in treated wood before it is used. If they do, the affected timber should be placed

in the structure so that water cannot flow into the check or crack and, thus, promote rot in the untreated heartwood. Seasoning checks or cracks in piles also provide entry for marine borers to the untreated heartwood and, thus, allow for rapid destruction of such piles.

2.1.7 HARDWARE. Bolts, washers, nuts, spikes, drift pins, and other hardware used in timber structures shall be heavily galvanized.

SECTION 2. INSPECTION

Investigation of wood structures is necessary to detect voids and other deficiencies before they become serious.

Observations should include:

- (1) Losses of cross-sectional area
- (2) Types of organisms present
- (3) Location and extent of damage
- (4) Defects (i.e., splits, checks, holes, or hollowed-out areas)
- (5) Alignment problems

(6) Condition of fastenings and surrounding material

(7) Overall evaluation of the structure and "degree-of-hazard"

2.2.1 EXPOSED AREAS. Above the water line where fungus rot can occur, inspection consists of visual examination, sounding with a hammer, probing with a thin-pointed tool, such as an ice pick, and by taking a boring.

2.2.2 SUBMERGED SECTIONS. From the mud line to high water, assistance from divers is required. (See Reference 2-4.) Observation from a boat even in clear, shallow water is unsatisfactory. There are two ways to inspect wood underwater: visually and ultrasonically. Visual inspections require removal of fouling to make accurate estimates of damage. This is accomplished by divers using hand axes, scrapers, or pneumatic tools. Although the work proceeds slowly and is fatiguing to a diver, this method is the one most widely used. Some fouling removal has been done by blasting and by air-

powered machines equipped with rotating brushes that move along the pile surface.

When the diver or activity determines the need to make additional investigations for internal voids, ultrasonic equipment may be used. Under "normal" conditions about 100 piles can be inspected in one day. It is not necessary to remove fouling from the piles if the fouling does not increase the pile diameter by 1 foot or more.

SECTION 3. MAINTENANCE

2.3.1 REPLACEMENT

2.3.1.1 Bearing Piles. Bearing piles that have lost more than 50% of their cross-sectional area or have been broken should be replaced. The existing pile should be pulled and a properly treated one driven in its place (Figure 2-7). When an existing pile cannot be pulled or broken off, it should be cut off as far down as possible, and the replacement pile should be driven alongside the stub, pulled into place under the cap, and fastened to it with a drift pin and with fish plates. A more satisfactory installation would be to cut off the old pile below the mud line and cover the stub with backfill once the replacement pile is driven.

2.3.1.2 Pile Caps. Decayed or damaged pile caps should be replaced with properly treated members as described in 2.1.4. Replacement caps shall be the same size and length as the original member unless redesigned.

2.3.1.3 Braces. Diagonal braces that have been attacked by fungi or marine borers or have been broken

should be replaced completely rather than be spliced. After they have been drilled, bolt holes should be treated with a preservative. Where braces are fastened to a piling, the pile should not be cut or dapped to obtain a flush fit. Braces should be located well above high water. Where decking has been removed for repairs, it is often possible to drive diagonal brace piles to provide lateral stiffness. This procedure eliminates all bolt holes except those at the top of the structure immediately below the decking.

2.3.1.4 Stringers. Decayed or damaged stringers should be replaced with properly treated members. Replacement stringers should be tightly bolted to existing stringers which are to remain in the structure. Connections between replacement and existing stringers shall be made directly over a pile cap and they should be bolted or pinned to the pile cap. Decayed or damaged

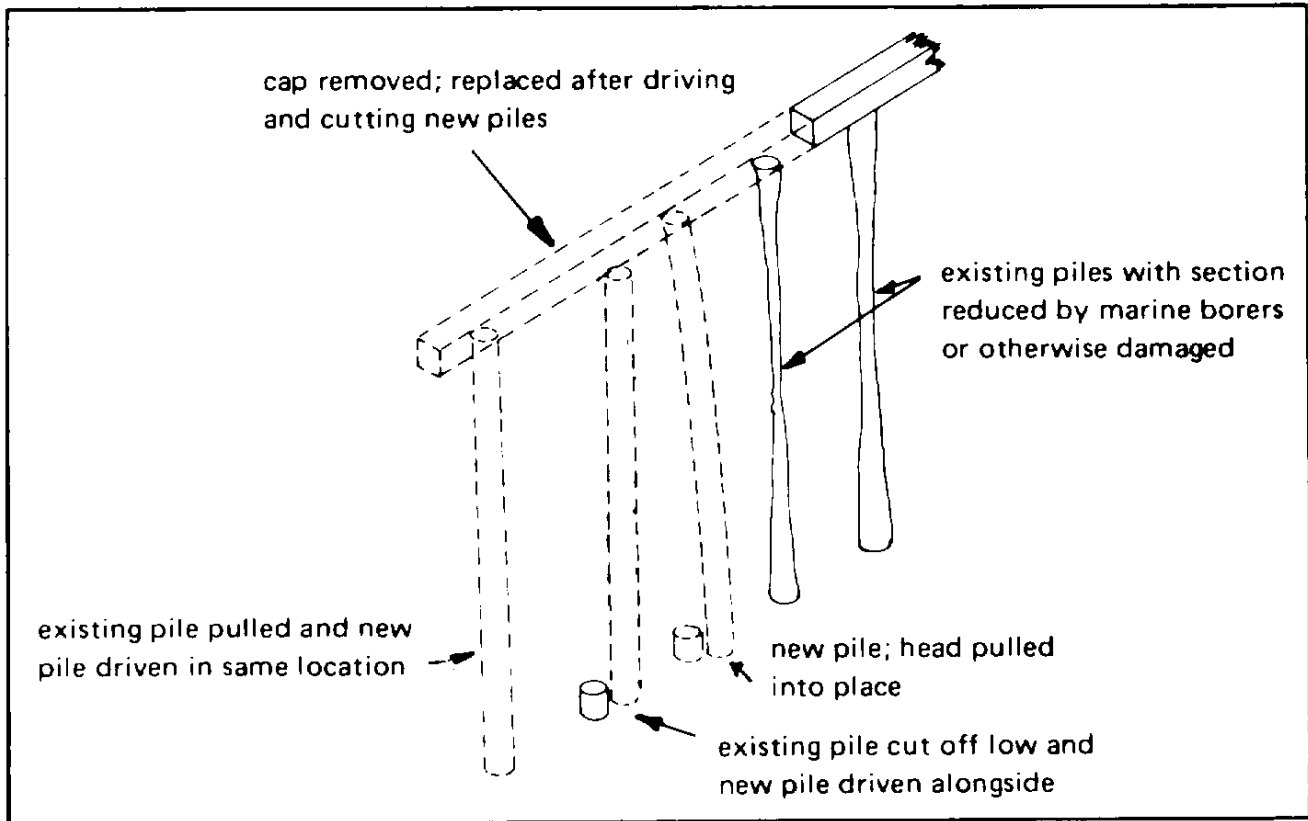

Figure 2-7. Wood pile replacement.

areas of long stringers can be removed and replaced with properly treated new sections. Again, splices should be made directly over a pile cap; splices in adjacent stringers should be staggered where possible. A typical splice is shown in Figure 2-8.

2.3.1.5 String Pieces. The string piece, sometimes referred to as the curb, bullrail, or backing log, is subjected to much wear and to constant wettings and dryings. Properly treated replacement sections should be long enough to reach between a minimum of two bents. New preservative-treated blocks, 2 to 3 inches thick, should be placed under each replacement section on 3-to-4-foot centers to provide for drainage. If any part of the lower string piece has deteriorated, the entire piece of timber should be replaced (see Figure 2-9).

2.3.1.6 Chocks. Deteriorated chocks should be replaced by properly treated, tightly fitting chocks that are bolted to one string piece or to a waler below the

deck (see Figure 2-10).

2.3.1.7 Decking. Decking over which vehicular and pedestrian traffic passes should be replaced when its top surface becomes excessively uneven, hazardous, or worn to a point of possible failure. It should be replaced with properly treated quarter-sawn timber. Spacing between decking planks should be provided for ventilation and drainage. Decking for relieving platforms which have an earth fill should be laid in a double layer without spacing between the planks.

2.3.1.8 Fire Curtain Walls. Wood fire curtain walls are usually made of two layers of planking which run diagonally to one another. All deteriorated planks should be replaced to restore the wall to its original condition - as airtight as possible.

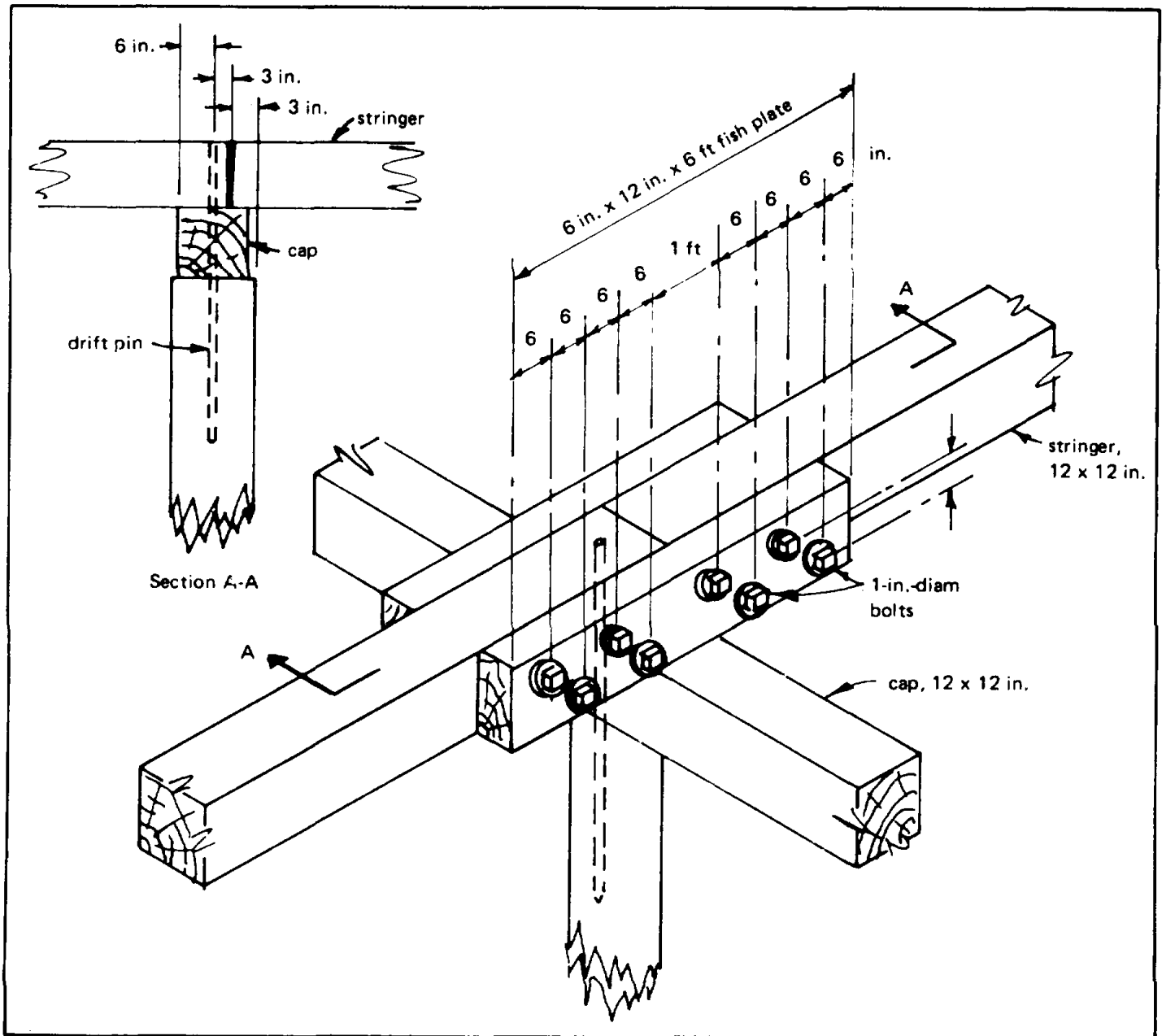

Figure 2-8. Stringer splice.

2.3.1.9 Fender Piles. Decayed, marine borer attacked, or broken fender piles that cannot be adequately repaired should be pulled and replaced with a properly treated new pile. Installation of a steel "shoe" on the outer (wearing) surface of each fender pile is recommended. Adequate camel logs should be provided.

2.3.1.10 Sheeting. Piers and quay walls may have wood sheet pile bulkheads to retain fill on the shore side. Deterioration of these bulkheads results in loss of fill and settlement of the material above the affected areas. In the early stages of deterioration, repairs can be made by using a plastic marine splash-zone compound, such as an epoxy-polyamide.

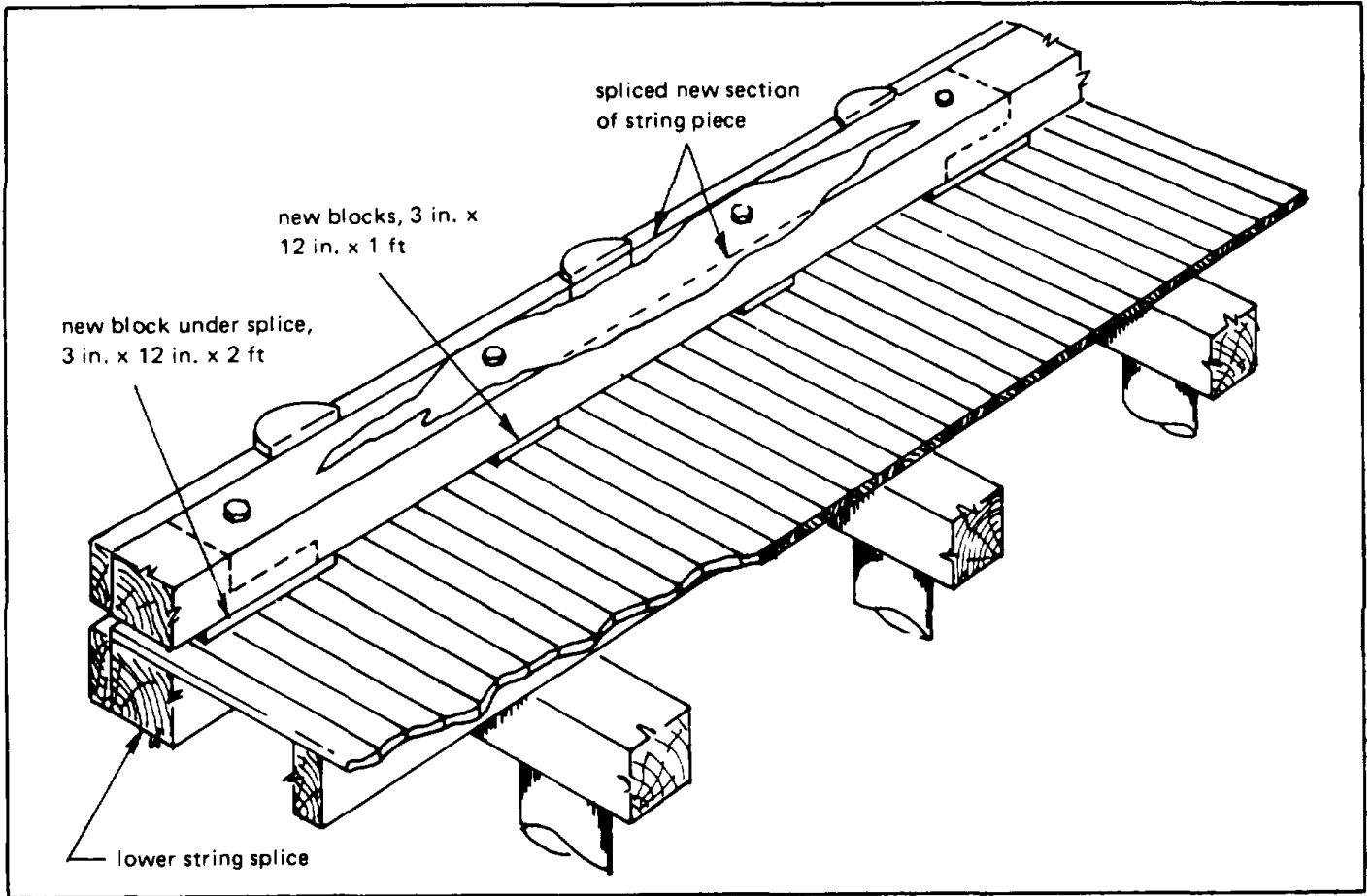

Figure 2-9. Repair of string piece.

When deterioration is more extensive, sheet piling is driven to form a new bulkhead a minimum of 1 foot behind the existing one in order to avoid the driving frames or wales attached to it. Steel sheet piling, driven to a minimum of 3 feet below the toe of the deteriorated wood sheeting, is normally used for the new bulkhead. The fill at the inside edge is normally removed before driving the new sheet piling. When this is done, a concrete cap should be placed over the new sheeting to form a seal with the existing construction.

2.3.1.11 Dolphins. The maintenance of timber dolphins includes the replacement of fastenings and any wire rope wrapping that has become defective through corrosion or wear. The maintenance of a catwalk that connects dolphins includes the replacement of damaged or deteriorated timbers; steel members should be cleaned and painted, or replaced. The repair of dolphins includes replacement or rehabilitation of piles, wire rope wrappings, and blocking. If it is necessary to replace any piles, the fastenings should be removed only as far

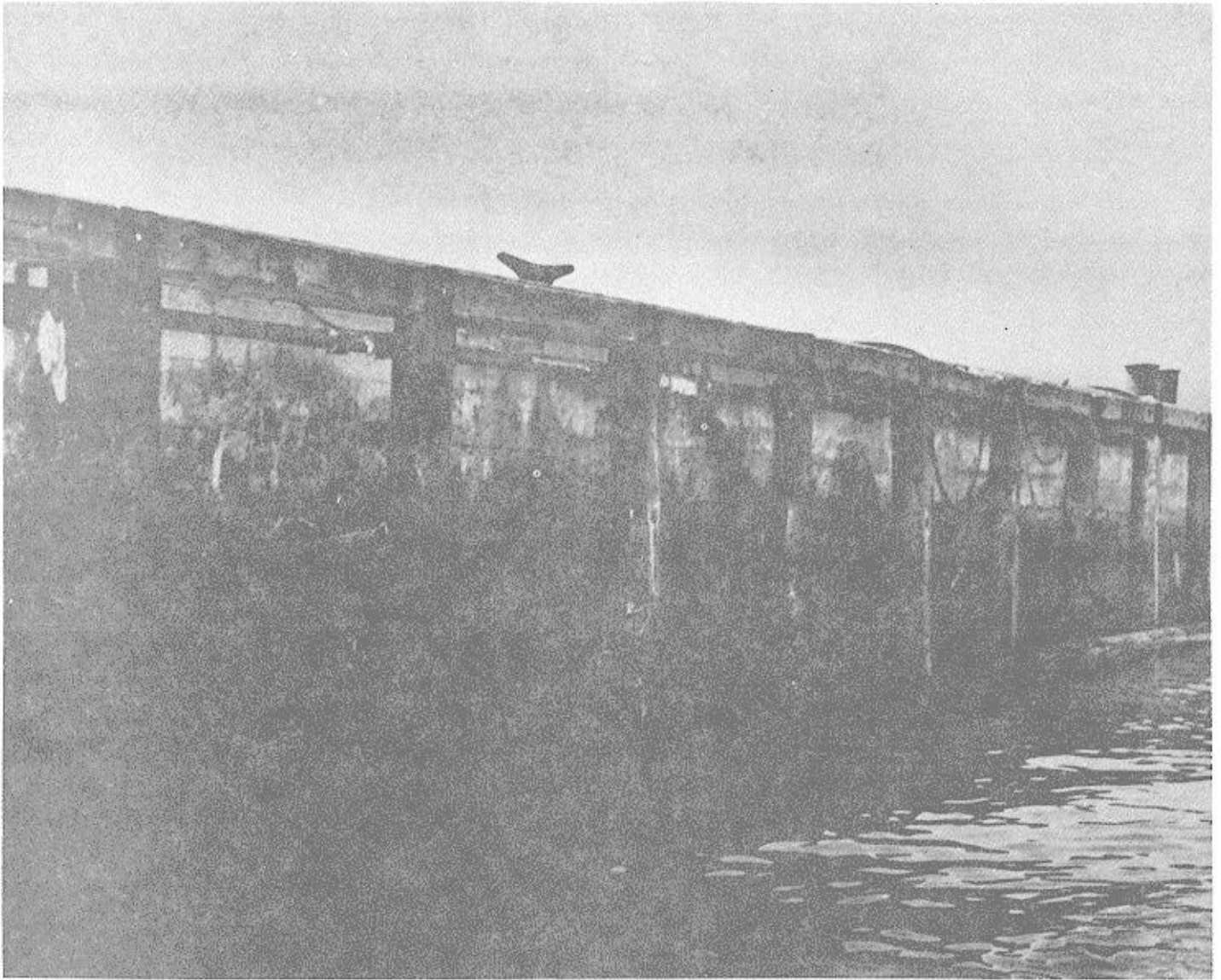

Figure 2-10. 100% deterioration of chocks, lower wales, and fender piles.

as is necessary to release the piles that are damaged. Care should be taken to drive the new piles at the proper angle so that they will not have to be pulled too far to fit them in place. The size of piles to be replaced should be carefully noted, particularly at the head or intermediate point where they are fitted together with the other piles. Much trouble in cutting and fitting the replacement piles can be avoided by selecting piles with the proper size head. All replacement piles should be driven before any are brought together. After all piles

are driven, the center cluster should be brought together first, fitted, chocked, bolted, and pinned; when all rows have been properly fitted, etc., they are then wrapped with wire rope. All cuts in piles for fittings, bolts, and wrappings should be thoroughly field-treated with creosote. These cuts should be avoided if at all possible, however, because field treatment with creosote gives only marginal protection against marine borer attack.

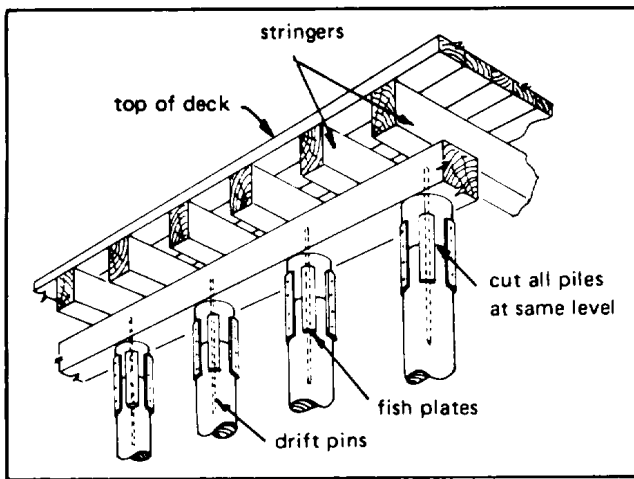

Figure 2-11. Replacing tops of piles.

2.3.2 REPAIR

2.3.2.1 Decayed Bearing Piles. The decayed top of a wood bearing pile can be repaired by cutting off the damaged portion and fumigating the exposed cut-off to destroy any remaining hyphal threads. A section of sound timber is installed and secured with epoxy cement or drift pins and fish plates to build the pile to the proper height (see Figure 2-11).

2.3.2.2 Marine-Borer-Damaged Bearing Piles. Wood bearing piles that have lost 10 to 50% of their cross-sectional area can be repaired by any of several methods.

2.3.2.2.1 Flexible Barrier. When a diver or ultrasonic inspection reveals that a pile has lost approximately 10 to 15% of its cross-sectional area because of marine

borer attack, a flexible PVC barrier may be installed (Figure 2-12). An in-place barrier not only prevents further attack on a pile, but it also creates a stagnant area between it and the pile surface, thus killing organisms already present on or within the pile. In this method, the pile is sheathed with a prefabricated unit consisting of a 30-mil PVC sheet with a full-length, half-round apitong wood pole piece attached to each vertical edge. Lengths of flexible polyurethane foam, 1/2 x 3/6 inch, are stapled about 1 inch from the upper and lower horizontal edges. When only the intertidal area is to be sheathed, the PVC wrap is placed around the pile, and the pole pieces are fitted together with one inserted into a pocket attached to the bottom of the other. The excess material is rolled on the combined pole pieces and tightened around the pile with a special ratchet wrench. Aluminum alloy nails are driven through the rolled material and the pole pieces to secure the wrap initially. Then rigid plastic bands are nailed at the top and bottom directly over where the polyurethane foam is located under the wrap. Additional bands are installed on equidistant centers between the top and bottom bands. For protection extending to the mud line, approximately 12 inches of soil is excavated around the pile, and the wrap is placed around the pile, lowered into the excavated area, and secured as above. Then the excavated area is backfilled with soil. When it is necessary to wrap a pile that has creosote bleeding from its surface, a sheet of polyethylene film is stapled to the pile surface prior to installing the PVC wrap. (Creosote will soften and swell PVC, but it does not affect polyethylene.)

2.3.2.2.2 Concrete Barrier. When a diver or ultrasonic inspection reveals that a pile has lost approximately 15 to 50% of its cross-sectional area because of marine borer attack, a reinforced concrete barrier may be installed.

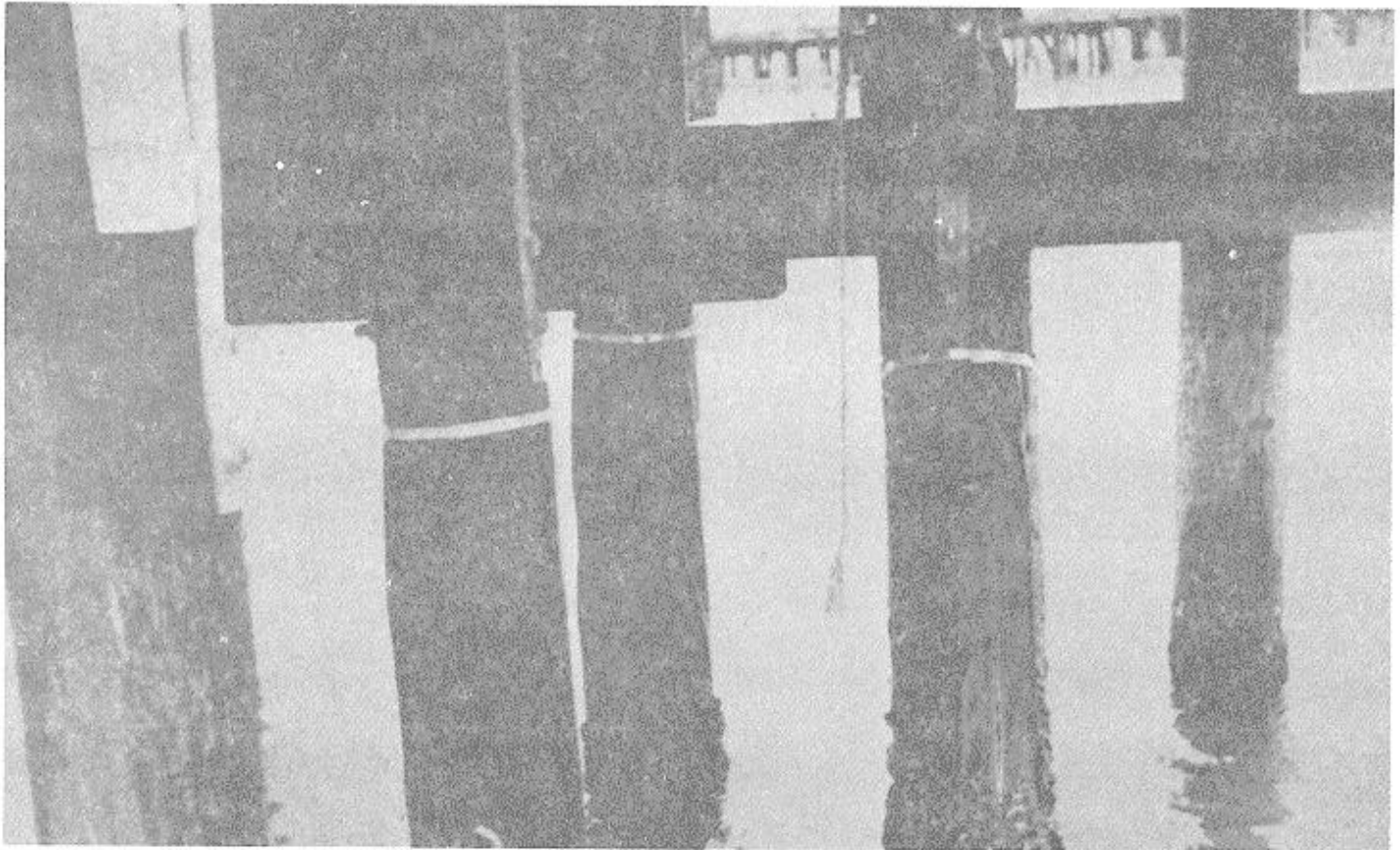

Figure 2-12. A flexible PVC barrier installed on wooden piles.

Various types of metal, nylon mesh, and pitch-impregnated fiber tube forms can be used. Two very important requirements for installations of this type are (1) a tight bottom seal between the form and the pile, and (2) a grout-dispensing pipe that extends to the very bottom of the form so that seawater within the form can be pushed up and out by the rising column of pumped-in grout.

Another system uses a reinforced plastic jacket which is placed to within 1/8 inch of the pile surface. A two-component resin mix is prepared, an equal part of fine sand is added, and this mortar is poured slowly into the void to replace the water.

2.3.2.2.3 Replace Section. Replacement of damaged wood pile sections with a reinforced concrete pile section can be accomplished as follows: soil is excavated at the mud line, the damaged pile is cut off

where undamaged wood is present, and the section is removed from the structure. In one patented method, a specially designed, partly reusable form is clamped to the pile stub and to the pile cap. Grout is pumped through a hose connected to a nipple in the lower form clamp and is continued until the grout reaches the pile cap. When the concrete has set, the upper and lower form clamps are removed, and the expendable form tube is left in place.

2.3.2.3 Braces. A diagonal brace, which extends into the water and has been lightly attacked by marine borers, can be saved by (1) removing the bolt which secures it to the pile, (2) wrapping the freed end with 20-mil flexible PVC sheet in a manner similar to applying electrical tape to a cut-off wire, (3) driving the bolt through the wrapping and through the existing hole, and (4) rebolting the brace to the pile.

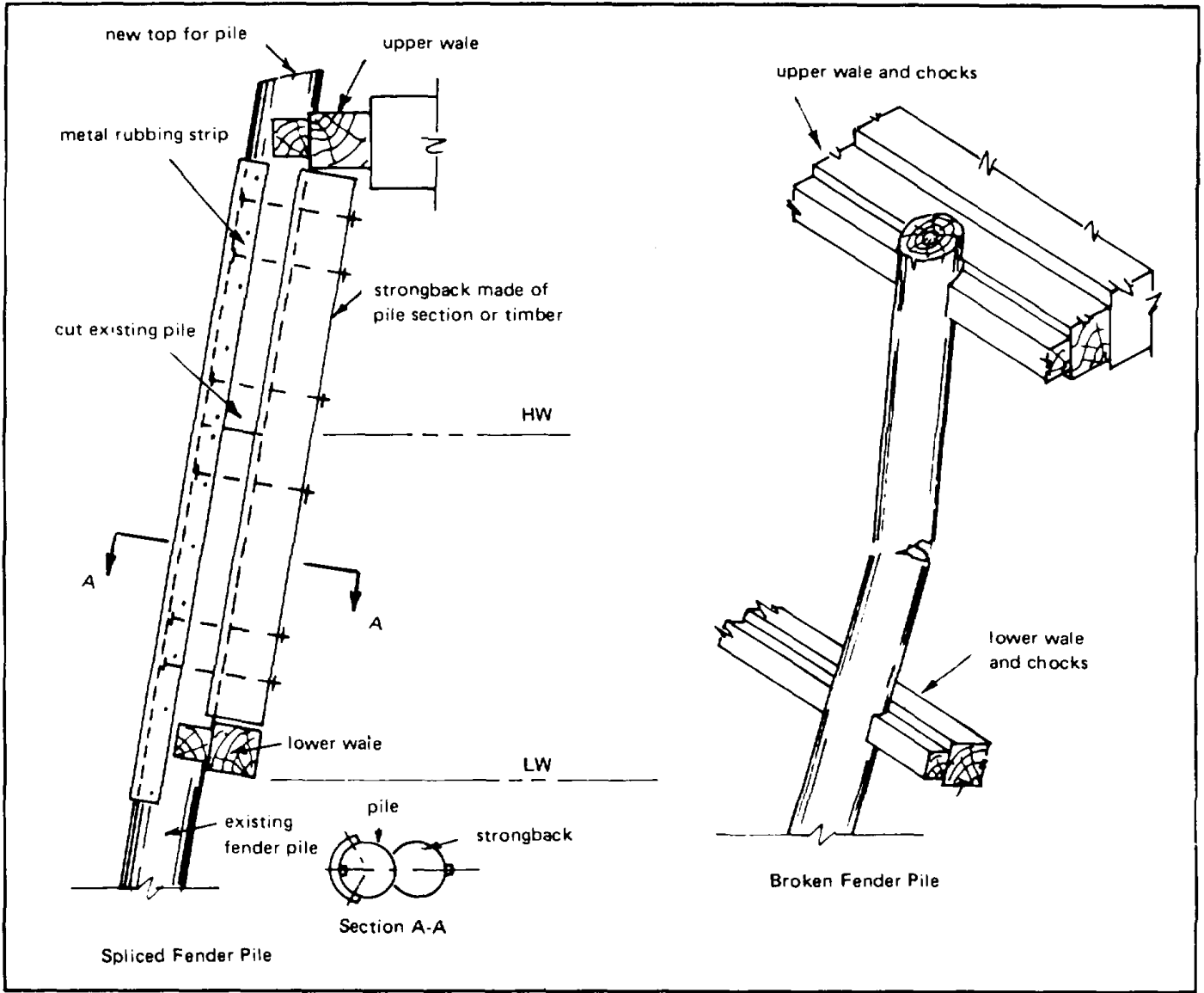

Figure 2-13. Fender pile repair.

2.3.2.4 Fender Piles. Fender piles that have been broken between the top and bottom wales can be repaired by cutting off the pile just below the break, installing a new section of pile, and securing with epoxy cement. A strongback (pile or timber section) is fitted

and bolted in place directly behind the fender pile and between the top and bottom wales. A metal "shoe" (wearing strip) should be attached to the wearing edge of each fender pile (see Figure 2-13).

CHAPTER 3- CONCRETE STRUCTURES

SECTION 1. CONCRETE TECHNOLOGY

3.1.1 DEFINITION OF CONCRETE. Concrete is a mass of sand, gravel, crushed rock, or other aggregate bonded together by a hardened paste of hydraulic cement and water. When properly proportioned, mixed, and consolidated, these ingredients form a workable mass which can be placed into a form of desired size and shape. The water present reacts with the cement to convert the concrete to a hard and durable product.

3.1.2 COMPONENTS OF CONCRETE

3.1.2.1 Cement. Cement is a kiln-dried and finely pulverized mixture of natural earth materials used as a bonding ingredient in concrete or mortar. Of the five types of cement defined by the American Society for Testing and Materials (ASTM), only Types II and V should be considered for concrete structures that come into contact with seawater. Type V is the recommended product for such structures because of its high resistance to sulfate attack (a form of disintegration occurring in seawater and other high salt environments). The more commonly produced Type II, which has a moderate resistance to sulfate attack, can be used when high cement factors (more than 7-sack) are necessary. This will result in low water/cement ratios.

3.1.2.2 Aggregate. Aggregate is the inert filler material in concrete that permits good physical properties (see 3.1.3) at a low cost. It usually consists of natural sand

and gravel, crushed rock, or mixtures of them. Other aggregates, such as blast-furnace slags, manufactured sand, or crushed coral, are used when the more commonly used aggregate is unavailable. The aggregate portion generally constitutes about 75% of the volume of the concrete. Particle size is usually limited to three-fourths the distance between reinforcing bars or one-fifth the minimum dimension, and never more than 3/4 inch. Particles of various sizes should be uniformly distributed throughout the mass and properly graded for dense packing. The quality and gradation of aggregate should conform to ASTM requirements.

3.1.2.3 Water. Water not only changes the concrete mixture to a workable consistency suitable for placing in a mold or forms for a desired size and shape, but it is a necessary ingredient to react with the cement, called hydration, which converts the cement to a hardened mass. The ratio of water to cement (W/C) is largely responsible for determining the strength of the concrete. This ratio, which excludes water absorbed by the aggregate, is expressed as a decimal (on a weight ratio basis) or as gallons of water per standard 94-pound bag of cement. See Table 3-1 for the relationship between these two methods of expressing W/C. The water used in mixing concrete must be clean freshwater. Potable

Table 3-1. Relationship Between Methods of Expressing Water-to-Cement Ratio

Gallons/Bag	Weight Ratio
4	0.36
4.5	0.40
5	0.44
5.5	0.49
6.0	0.53
6.5	0.58
7.0	0.62
7.5	0.66
8.0	0.71
8.5	0.75
9.0	0.80

Weight Ratio	Gallons/Bag
0.35	3.94
0.40	4.50
0.45	5.07
0.50	5.63
0.55	6.20
0.60	6.76
0.65	7.32
0.70	7.88
0.75	8.44
0.80	9.00

water is most commonly used; water with a high mineral or salt content, even though it may be called potable, may not be suitable.

3.1.2.4 Admixtures. Admixtures are materials other than cement, aggregate, or water that are added to the

batch of concrete immediately before or during mixing to impart desirable properties to it. Water-reducing admixtures permit the use of less water to give a concrete mix equal consistency that may result in a final product of greater strength, watertightness, and durability. Air-entraining admixtures are used to increase the resistance of hardened concrete to cycles of alternate freezing and thawing and to improve the workability of the concrete mix. For all concrete structures exposed to seawater, the entrained air content should be between 4-1/2 and 6%. Air entrainment will result in decreased strength, but it can normally be counteracted with more cement. Air entrainment in amounts significantly greater than 6% should be tested for strength. Accelerator admixtures are used to increase the early strength of concrete. Some accelerator admixtures contain chloride and should only be used for temporary construction. All admixtures should only be used when necessary.

3.1.3 DESIRABLE PROPERTIES OF CONCRETE

3.1.3.1 Workability. The concrete composition should be such that it is easily mixed, handled, transported, and placed with vibrators without loss of homogeneity.

3.1.3.2 Strength. Much of the strength of concrete is related to the amount of mixing water used (W/C ratio). Thus, the common field practice of adding more water to improve workability at a sacrifice in strength should be avoided. As shown in Figure 3-1, the W/C ratio affects compressive strength much more than tensile and flexural strengths. Compressive strength increases with the age of the concrete. The average portland cement

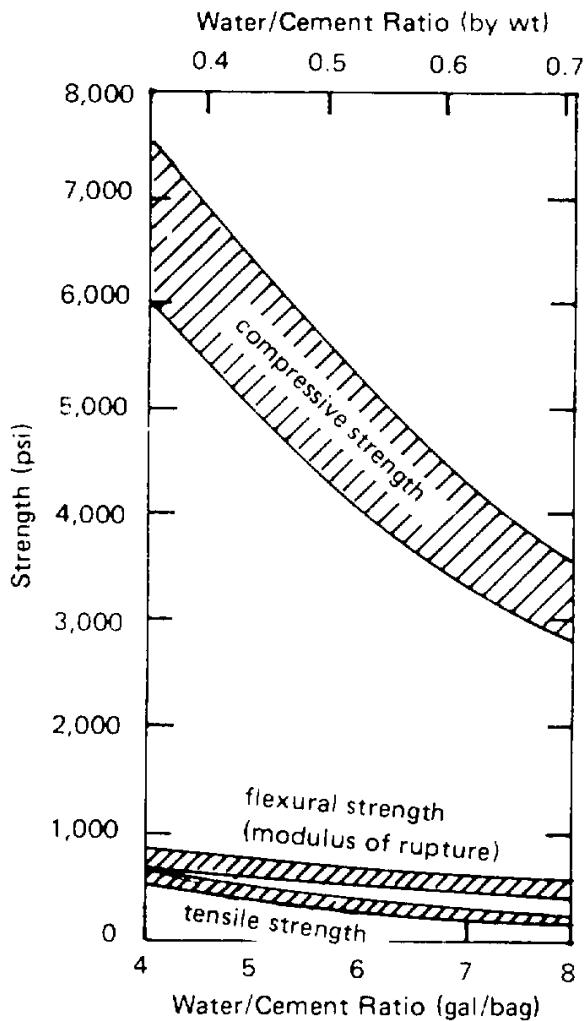

Figure 3-1. Effect of water/cement ratio on 28-day compressive, flexural, and tensile strengths.

concrete develops about 75% of its 28-day compressive strength after 7 days. After 1 year it is about 150% of the 28-day value, and after 5 years, 200% of this value. The hardening process begins at final set and continues indefinitely with favorable curing temperatures. The favorable temperature range extends from 50° to 90°F.

The lower the curing temperature within this range, the greater the assurance of proper curing. Too rapid a loss of water at a higher temperature may result in shrinkage cracks. When concrete is poured at temperatures appreciably below 50°F, special heating and/or insulating techniques must be employed to raise the temperature to a more favorable level.

3.1.3.3 Durability. A durable concrete will exhibit resistance to weathering, chemical deterioration, and erosion. Concrete composition is the most important factor related to durability. The cement content should be not less than 8 bags per cubic yard, and the aggregate/cement ratio not less than 2.6 (by weight). The durability of concrete exposed to freezing and thawing is enhanced by use of air-entraining admixtures. Note that newly poured concrete must not be allowed to freeze.

3.1.3.4 Watertightness. Excess water in the concrete mix creates voids or cavities which increase permeability. Thus, a proper W/C ratio is very important as is prolonged, thorough curing for watertightness. However, with an 8-sack mix, one should be able to obtain a proper W/C ratio 0.45 or less.

3.1.4 SPECIAL CONCRETES FOR WATERFRONT STRUCTURES

3.1.4.1 Prestressed Concrete. Prestressed concrete is a special type of reinforced concrete containing stretched tendons of steel (bars, cables, wire ropes). The steel is considered pretensioned if it is stretched before the concrete attains initial set. It is considered post-tensioned if it is stretched after the hardened concrete has obtained a specified strength; the unstretched steel is first encased within ducts to prevent its bonding to the concrete. If the concrete was steam-cured, it will not be equally as durable as a concrete that was simply water-cured for the same period of time.

3.1.4.2 Fiber-Reinforced Concrete. A new approach to reinforcing concrete is the use of steel fibers, about 0.014 inch in diameter and 1.5 inches long, uniformly distributed and randomly directed throughout the concrete mix. Such fibers can be utilized either in ordinary reinforced concrete or prestressed concrete to increase the tensile strength and resistance to cracking.

3.1.4.3 Underwater Concrete. Concrete poured underwater must have good workability and, thus, should meet the following conditions:

(1) The mixture must incorporate the proper proportions of sand and gravel (preferably not crushed material) in a rich paste of portland cement and freshwater.

(2) The mixing water must not exceed 5.5 gallons per bag of cement. (Mixing water includes the water entering the batch in the form of free, surface moisture on the sand and/or gravel; this free water must, therefore, be deducted from the total water to be added.) If the aggregate particles are surface-dry and not saturated, they will absorb some of the gross mixing water; allowance must, therefore, be made for extra mixing water, taking care that the W/C ratio of 5.5 gallons per bag is not exceeded.

(3) The mixture should not contain less than 8 bags and not more than 10 bags of cement per cubic yard of ASTM Type V concrete. (Type II may be used if Type V is unavailable; see Section 3.1.2.1.)

(4) For improved workability, the concrete should incorporate an admixture to provide not less than 3% and not more than 6% entrained air as determined by standard ASTM methods.

(5) The sand and gravel should be physically sound, and the maximum gravel size should be 3/4 inch

The aggregate should be graded as indicated in Table 3-2.

(6) The formwork in which the concrete is poured must be rigid, carefully fitted, and designed so that no underwater currents can pass through it. Provision must be made for the seawater displaced by the concrete to escape from within the form. Timber is generally the most suitable material for construction of the formwork. Joints between the formwork and the intact portion of a structure should be caulked.

(7) Low temperatures during mixing and curing of concrete (i.e., below 50°F) can delay strength development for periods as long as one year and so should be avoided.

(8) An enclosed chute or "trunk" should be specified so that there is no mixing with water during placement.

Table 3-2. Gradation of Aggregates for Tremie Concrete

Aggregate	U.S. Standard Sieve	Percent Passing (by wt)
Gravel	3/4 in.	90 to 100
	3/8 in.	20 to 55
Sand	No. 4	0 to 10
	No. 8	0 to 5
	3/8 in.	100
	No. 4	95 to 100
	No. 8	80 to 100
	No. 16	50 to 85
	No. 30	25 to 60
No. 50	10 to 30	
No. 100	2 to 10	

SECTION 2. CAUSES AND TYPES OF DETERIORATION

3.2.1 CAUSES OF CONCRETE DETERIORATION. In addition to improper mix composition there are several important causes of deterioration to concrete structures in or near seawater.

3.2.1.1 Normal Weathering. Normal, gradual weathering (aging) by sun, wind, and water is usually indicated by slight erosion of the concrete surface (e.g., rounded corners and surface pits). This is normally the result of minor salt, sulfate, or freeze-thaw attack.

3.2.1.2 Accelerated Weathering. Fine cracks are evidence of accelerated weathering by a severe environment or the lack of proper curing, as well as other causes of deterioration.

3.2.1.3 Chemical Attack. Sulfate attack of the concrete by seawater usually results in softening of the concrete and subsequent crumbling. Chemical reaction between the aggregate and the alkalies in the cement usually results in wide (up to 1-1/2 inches) and deep (several inches) cracks.

3.2.1.4 Volume Change. Volume changes can be caused by thermal expansion and contraction, freezing and thawing, changes in moisture content, and chemical reaction between the aggregate and the alkalies in the cement. These create tensile stresses in the concrete that may result in cracking and spalling. The most frequent cause of such damage in reinforced concrete is the corrosion of the embedded steel and resultant stresses caused by the greater volume occupied by the corrosion products than the original steel.

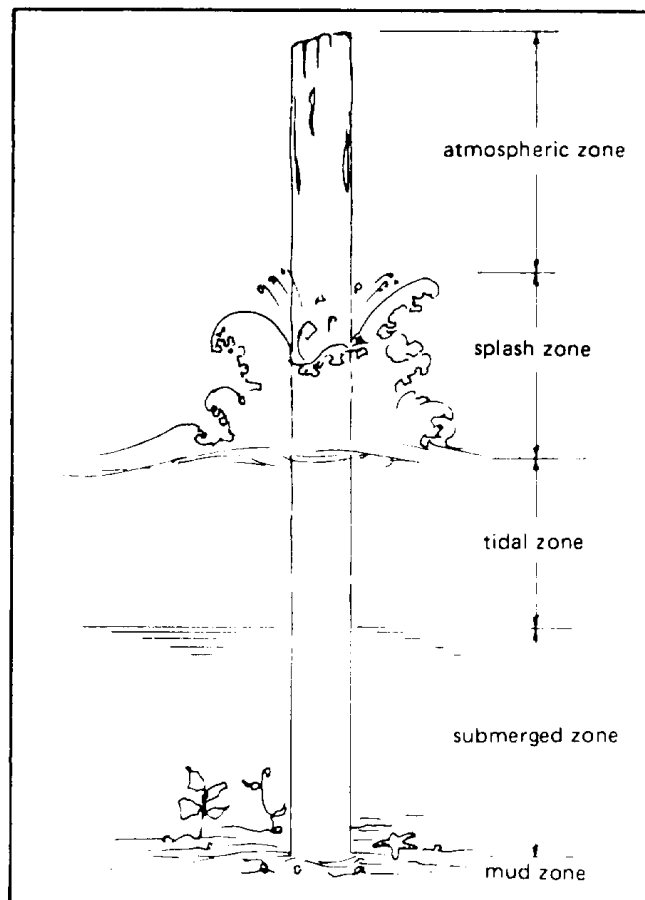

Figure 3-2. Exposure zones.

This type of damage is usually first observed in the splash zone area (see Figure 3-2), but it also occurs above the splash zone and has been found in continuously submerged concrete. Corrosion of steel in reinforced concrete is usually first evidenced by rust stains on the surface of the concrete. The best way to prevent this type of deterioration in piles is to place at least 3 inches of dense concrete (8 sack) over the steel.

Corrosion of the steel has been observed when the chloride-ion content of the concrete is more than 1.0

to 1.3 lb/cu yd of concrete. Caution must be exercised when using water or aggregates that contain salt. Corrosion of the steel could begin from the day the concrete was cast.

3.2.1.5 Improper Finishing or Curing Practices. Improper finishing or curing practices can cause craze cracking of the concrete.

3.2.1.6 Plastic Shrinkage. Excessively rapid evaporation of water from concrete surfaces can cause plastic shrinkage cracking.

3.2.1.7 Structural Settlement. Structural settlement or unstable subgrade can allow concrete to shift during setting and, thus, cause cracking.

3.2.1.8 Mechanical Damage. Mechanical damage of hardened concrete can be caused by impact or abrasion, such as by floating debris or ice.

3.2.2 TYPES OF CONCRETE DAMAGE

3.2.2.1 Cracks. As indicated in 3.2.1, cracks may be due to many different causes or a combination of them. Cracks resulting from other causes may be aggravated by (1) loads that produce stresses on structural members, (2) restraints to volume changes, (3) thermal stresses, and (4) settlement. The maximum permissible width of cracks before an engineering investigation is initiated is 0.1 inch regardless of the loading and environment. (See Reference 3-1 for a crack repair method.)

3.2.2.2 Spalls. A spall is a thin fragment of concrete that becomes detached from a large mass of concrete by impact, expansion, or weathering. When caused by corrosion of underlying reinforcing steel, it is usually preceded by cracking.

SECTION 3. METHODS OF INSPECTION

3.3.1 VISUAL. All cracking, spalling, chipping, rust staining, and other visual signs of deterioration should be described in written form. The condition of any exposed reinforcing steel should also be noted. The measured location of all damaged areas should be recorded. Areas of inspection and repair should be on a zonal basis. The five zones, as shown in Figure 3-2, are (1) atmospheric; (2) splash zone, which extends about 6 feet above the tidal zone; (3) tidal zone, from low to high water level; (4) submerged zone, which is continuously wet; and (5) mud zone, which can only be inspected after excavation. Visual observations of significant problem areas should be fully documented with

photographs and/or video tapes.

Soundness of concrete should be determined by tapping with a hammer, as the actual condition may not be apparent from mere observation. In many instances of shallow spalling, a veneer of damaged concrete is loosely held in place. The only concern for repair of shallow spalls is appearance.

Where deterioration is extensive (Figure 3-3), enough concrete should be removed to indicate the extent of needed repair. The depth of damage can best be determined by chopping away a small section with a

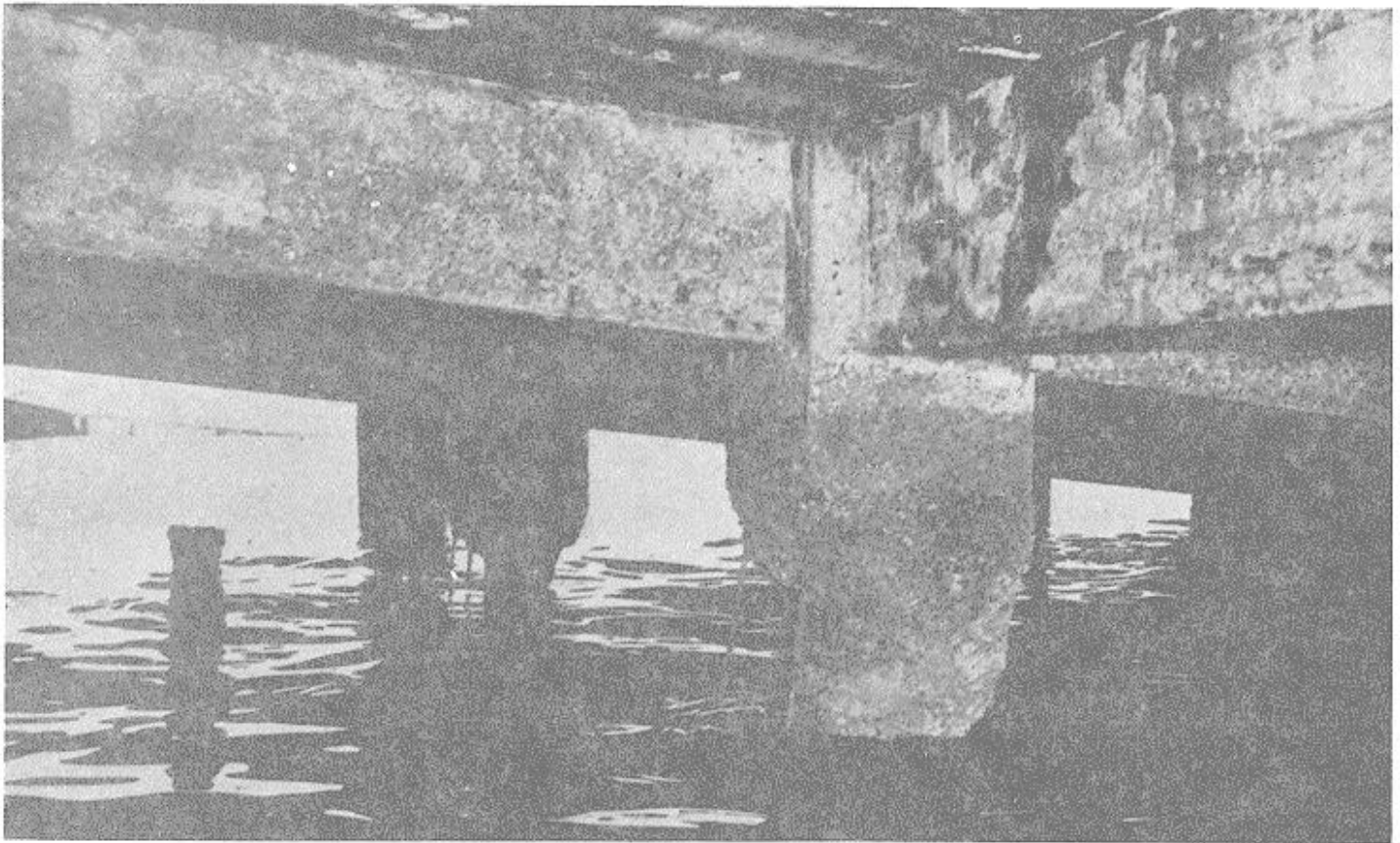

Figure 3-3. Concrete piles in advanced stage of deterioration.

sharp tool, such as a brick mason's or geologist's hammer. A sharp hammer is also useful in determining the soundness of repair work. An unmistakable ring from the blow of a hammer indicates sound material, while a hollow sound indicates loose material. Poorly bonded repair work is identified by a drumming sound. Probing with a gad (sharp pointed tool) can be used to determine the depth of damage.

The atmospheric, splash, and tidal zones of concrete piles can be inspected better from a skiff than from the edge of a deck. The submerged and mud zones (where exposed) should be examined by a diver or, where available and appropriate, an underwater television camera. Both piling and pile caps should be inspected for cracks, spalls (especially in the tidal zone

and along edges), disintegration, broken members, exposed reinforcing steel, and rust staining. Decks should be similarly checked, especially along the bottom edges. The general condition of all surfaces, especially wearing surfaces, and expansion joints should be noted. Graving docks should be inspected as described in Appendix B.

3.3.2 MECHANICAL. A reliable method of determining the condition of subsurface concrete is to extract diamond-drilled concrete cores that can be laboratory tested. Such specimens are usually obtained to (1) determine composition or the cause of the problem, (2) determine the depth or extent of deterioration, (3)

determine appropriate methods of repair, and (4) establish legal responsibility for the failure.

For structural elements that are not massive (e.g., decks of piers and wharves) and have a sectional thickness of less than 2 feet, the length of a drilled core should be equal to one-half the thickness but not less than 6 inches. The bottom inch of a deck should not be cored because the core could be lost by dropping out of the drill barrel; also, the core hole can be patched more readily. For massive sections (e.g., a seawall), the minimum depth of a drilled core should be 2 feet.

Another mechanical method of inspection uses a concrete test hammer, a portable, manually operated instrument for nondestructive testing of hardened concrete. This instrument measures the hardness or compressive strength of concrete by rebound of a steel plunger in a tubular frame. The hammer should be used only on surfaces where the concrete was cast against a form. Roughfloated or trowel-finished concrete surfaces will produce readings that do not truly indicate the quality of concrete. Readings vary with the age and moisture state of the concrete. Personnel using a test

hammer should be well-trained in its proper operation and calibration.

3.3.3 ELECTRONIC. Sonic and ultrasonic methods of inspecting hardened concrete measure the velocities of high frequency waves passing through a structural element. The sonic tester can be used on concrete as thick as 75 feet, while the ultrasonic instrument is limited to thicknesses less than 7 feet. Since sonic pulses do not traverse voids or air-filled cracks, these instruments can be used in detecting and evaluating imperfections and progressive deterioration.

Another method is the use of a standard reference cell and a high-impedance voltmeter. One lead is grounded to the reinforcing steel and the other is connected to the reference cell. The reference cell is touched to numerous locations on the concrete surface. This method can detect corrosion of reinforcing steel when there is no visual evidence of concrete cracking or distress.

Steel can be located by means of magnetic devices, such as a Pachometer.

SECTION 4. REPAIR METHODS

3.4.1 INTRODUCTION. Before planning a repair job it is essential to determine the cause of the problem: the concrete itself, the structural assembly, or both.

For proper repair of concrete structures all defective concrete must be removed, the concrete carefully replaced in accordance with an approved procedure, and effective drainage (where needed) provided.

Concrete that is stressed under loads must be supported properly before the defective portions are cut

away. The load on the beams must be removed, and/or the beam relieved of its structural load by shoring to avoid deflection. In the repair of piles that are small in cross section, if the removal of defective concrete could be detrimental to the stability of the structures, an attempt should be made to relieve part of its load.

Where possible, joints should be avoided between low and high tide levels. Patches should not be carried across active cracks or joints. Concrete used in

repairs must be protected and cured more carefully than usual. The old concrete could absorb moisture too rapidly from the new concrete, or the temperature of the old concrete could be too low to permit early development of strength of a concrete patch. The volume-change characteristics of the new concrete should correspond to those of the old to avoid differential movements that will weaken the bond.

3.4.2 DRY-PACK MORTAR. The dry-pack method should be used for (1) filling narrow slots that have been cut during the repair of dormant cracks, and (2) filling holes with a cross-sectional area not greater than 36 square inches and a depth equal to or greater than the least surface dimension. The dry-pack method should not be used for filling (1) shallow depressions (less than 1 inch) where lateral restraint cannot be obtained, (2) behind exposed reinforcing bars, or (3) holes that extend through a beam or bulkhead. The saw-tooth bit shown in Figure 3-4 is useful in cutting and undercutting slots and deep holes that are to be dry-packed. Regardless of depth, each hole or slot must be scrupulously clean, free of loose or cracked aggregate, and dry for at least 2 days before filling.

The cleaned interior surface is coated with a stiff bonding grout, immediately followed by the dry-pack mixture. The mix proportions for the bonding grout are 1 part of Type II portland cement to 1 part of fine sand (previously washed and dried), with only enough freshwater to produce a consistency like that of thick cream. The dry pack is a mixture (by dry volume or weight) of 1 part cement to 2-1/2 parts of sand passing a no. 16 standard sieve. The mortar patch is usually darker than the surrounding concrete unless special precautions are taken to match the colors. Where uniform color is important, white cement can be used in sufficient amount (as determined by trial) to produce the desired lighter color.

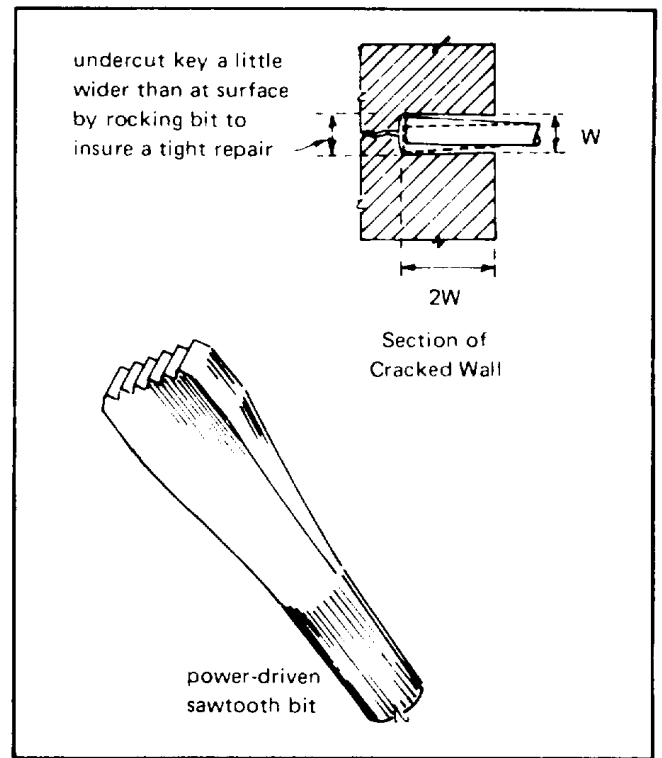

Figure 3-4. Sawtooth bit used to cut a slot for dry-packing.

The dry-pack material should be placed and packed in layers having a compacted thickness of about 3/8 inch; thicker layers cannot be well compacted at the bottom. The surface of each layer should be scratched to facilitate bonding with the next layer. One layer can follow another immediately unless appreciable rubberiness develops, in which event the repair should be delayed 30 to 40 minutes. Alternate layers of wet and dry materials should not be used, and the holes should not be overfilled.

Each layer should be fully compacted over its entire surface by using a hardwood stick and a hammer.

Finishing can usually be completed by laying the flat side of a hardwood piece against the fill and striking it several times with a hammer. A few light strokes with a cloth sometime later may improve the appearance. Neither steel finishing tools nor water should be used to facilitate finishing; otherwise, an ugly patch will result.

3.4.3 CAST-IN-PLACE CONCRETE. The cast-in-place method of restoring concrete should be used when: (1) holes extend through the concrete section, (2) holes in unreinforced concrete are more than 1 square foot in area and over 4 inches deep, and (3) holes in reinforced concrete are more than 1/2 square foot in area and deeper than the reinforcing steel.

All remaining concrete of questionable quality should be removed. Replacement of deteriorated concrete should be delayed several days until the soundness of the excavated surfaces and remaining concrete can be confirmed. Air-driven chipping hammers are most satisfactory for removing the concrete, although good work can be done by hand methods. A gad is better than a chisel because it leaves a rougher, more natural texture for bonding.

The square-cut edges required for many repairs can be sharply and neatly cut with a concrete saw. Small, electrically driven diamond saws with adjustable guide plates are available for depths up to 2-5/8 inches. An experienced operator can cut 20 feet of 1-inch-deep grooves in one hour. Heavier models are available for straight horizontal cuts, with cutting speeds up to 5 feet per minute. A sawed edge is much superior to a chipped edge, and sawing is generally less costly than chipping.

Surfaces within the trimmed holes should be kept continuously wet for several hours, preferably overnight, before placing the new concrete. The saturation of the old concrete will help in proper curing of the new concrete. Immediately before placement of the new concrete, the holes should be cleaned to leave a surface completely free of chipping dust, dried grout, and all other foreign materials that would deter bonding. Final cleaning of the surfaces to which the new concrete is to be bonded should be accomplished by wet sandblasting, followed by washing with an air-water jet for thorough cleaning; drying should be with an air jet. All shiny spots indicating surface moisture should also be eliminated.

Unnecessary tie wires should be removed from exposed reinforcement. Cleaning of the steel, if necessary, should be accomplished by abrasive blasting. All concrete repairs must be thoroughly moist-cured in order to be effective. If a high-strength bond is required and long moist-curing cannot be efficiently provided, either epoxy resin concrete or epoxy resin-bonded concrete can be used (see Section 3.4.8).

The preparations for the cast-in-place method of repair should be as follows:

(1) Holes should have a minimum depth of 6 inches. The minimum cross-sectional area of the opening should be 1/2 square foot in reinforced and 1 square foot in nonreinforced concrete.

(2) Steel reinforcing bars should not be left partially embedded; there should be a clearance of at least 1 inch around each exposed bar.

(3) The top edge of the hole at the face of the structure should be cut to a fairly horizontal line (see

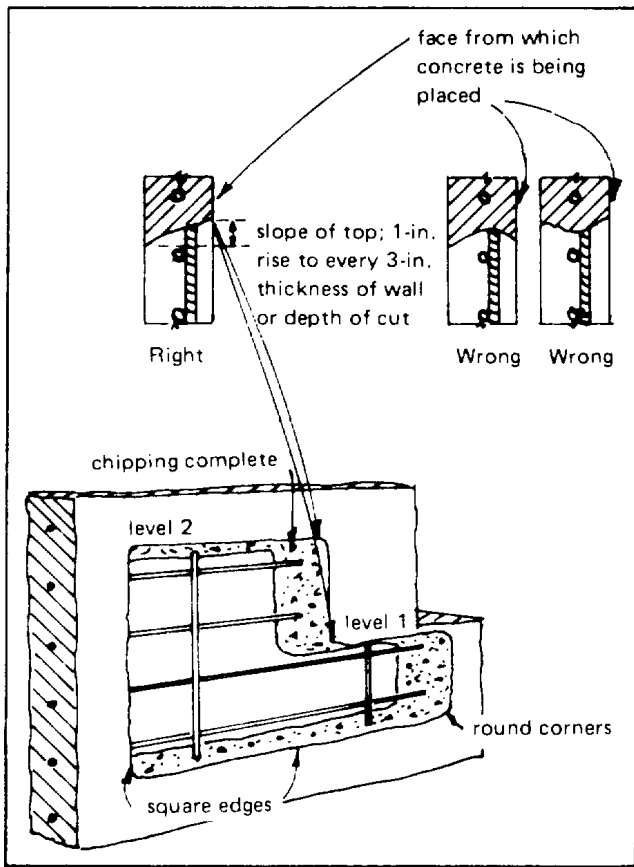

Figure 3-5. Excavation of irregular area of defective concrete where top of hole is cut at two levels.

Figure 3-5). Where a hole passes through a structural element, it may be necessary to fill the hole from both sides. In this case the slope of the top of the cut should be modified accordingly.

(4) The bottom and sides of the hole should be cut sharp and approximately square with the face of the wall. When the hole goes entirely through the concrete

section, spalling and featheredges can be avoided by having chippers work from both faces. All interior corners should be rounded to a minimum radius of 1 inch.

The construction and setting of forms are important steps in the procedure for satisfactory concrete replacement where the concrete must be placed from the side of the structure. Form details for walls are shown in Figure 3-6. To obtain a tight, acceptable repair the following requirements must be observed:

(1) Front forms for patches more than 18 inches high should be constructed in horizontal sections so the concrete can be conveniently placed in lifts not more than 12 inches high. The back form can be built in one piece. Sections to be set as concreting progresses should be fitted before concrete placement is started.

(2) For irregularly shaped holes, chimneys may be required at more than one level. In some cases, such as when beam connections are involved, a chimney may be necessary on both sides of the wall or beam. In all cases the chimney should extend the full width of the hole.

(3) Forms should be substantially constructed so that pressure can be applied to the chimney cap at the proper time.

(4) Forms should be mortar-tight at all joints between adjacent sections, between the forms and concrete, and at the tie-bolt holes to prevent the loss of mortar when pressure is applied to the concrete during the final stages of placement. Twisted or stranded caulking cotton, folded canvas strips, or similar material should be used as the forms are assembled.

Immediately before placing the front section of form for each lift, the surface of the old concrete (at the sides which will be covered by new concrete) should be coated with a 1/8-inch-thick layer of mortar. This mortar should have the same sand and cement content and the

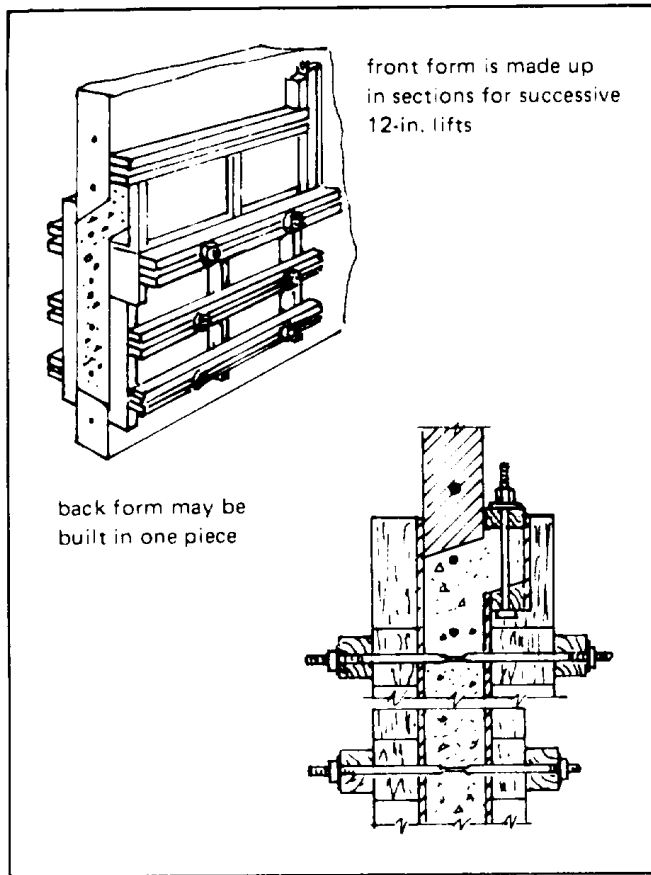

Figure 3-6. Details of forms for concrete replacement in bulkheads.

same W/C ratio as the mortar in the replacement concrete. The surface should be damp, but not wet. The mortar can be applied by means of an air-suction gun, by brushing, or by being rubbed into the surface with the hand encased in a rubber glove. Concrete placement should follow immediately. If the cross-

sectional area of the hole is greater than 36 and less than 72 square inches for reinforced concrete repair or 144 square inches for nonreinforced concrete repair, a no-slump concrete should be placed, thoroughly vibrated, and power tamped in 3-inch layers. If practicable, the new concrete should be preshrunk by letting it stand as long as practicable before it is tamped into the hole. The mix proportions and the aggregate gradation should be selected for minimum water content. The W/C weight ratio should be less than 0.40.

Casting concrete in open-top forms, as used for the reconstruction of the top of bulkheads and pier-deck curbs, is a comparatively simple operation. The W/C weight ratio should not exceed 0.45. No special features are required in the forms, but they should be mortar-tight when vibrated, and should give the new concrete a finish similar to that of the adjacent areas. The slump should be as low as practicable, and the amount of air-entraining agent increased as necessary to ensure the maximum permissible percentage of entrained air, despite the low slump. Top surfaces should be sloped so as to provide rapid drainage. Manipulation in finishing should be held to a minimum, and a wood-float finish is preferable to a steel-trowel finish. Edges and corners should be tooled or chamfered. Water should not be used to aid in finishing.

Forms for repairs involving cast-in-place concrete can usually be removed the day after casting unless form removal would damage the newly placed concrete. The projections left by the chimneys should normally be removed the second day. If the trimming is done earlier, the concrete tends to break back into the repair. These projections should always be removed by working up from the bottom because working down from the top tends to break concrete out of the repair.

3.4.4 SHOTCRETE. Shotcrete is satisfactory for repairing minor damage to concrete piles and framed structures and should be considered whenever there is enough repair work to justify the cost of the equipment. Piers, navigation locks, wooden piling, concrete piling, and steel piling are typical applications for shotcrete where waterfront repairs are necessary.

The advantages of shotcrete, compared with either regular concrete or prepacked concrete, are: (1) ease of placement, (2) minimum need for formwork and plant equipment, and (3) high strength. The comparative disadvantages of shotcrete are: (1) susceptibility to wide structural variation (composition is dependent on the skill of the nozzle man), (2) drying shrinkage rate and coefficient of thermal expansion can be considerably different than those of the original concrete in the structure being repaired, and (3) relatively high porosity.

Repairs and restorations accomplished by the shotcrete method are economical and successful where deterioration is shallow and the repaired area is large and irregular. In regions of severe exposure, periodic protective applications are necessary to seal cracks that allow the entry of water. More information can be found in References 3-2, 3-3, and 3-4.

With shotcrete, only that amount of water necessary for hydration is added to the mixture of aggregate and cement. Thus, shotcrete can be more dense than regular concrete, an important factor in the resistance of concrete to weathering. The ratio of cement to aggregate should never be greater than 1 to 3.5; these proportions will result in a ratio of about 1 to 2.5 (by weight) after gunning the shotcrete in place.

The recommended shotcrete procedure for

repairing a deteriorated waterfront structure is: (1) remove all defective concrete, (2) clean all rust off exposed reinforcement, (3) roughen all smooth surfaces and either wire brush or abrasive blast the exposed underlying concrete surfaces, (4) instill wire fabric and ensure that the laps do not project more than 3/4 inch from the surface of the underlying concrete, (5) fix the profiles, (6) fill out with shotcrete to the original face of the structure, and (7) apply not less than 2 inches of shotcrete (the final coat should not be less than 1/2 inch thick).

3.4.5 PREPACKED CONCRETE. Prepacked concrete is used on large repair jobs, particularly underwater placement or where placement of regular concrete would be either difficult or impossible. This method is used also in restoring old concrete and masonry structures. The advantages of either regular concrete or prepacked concrete, compared with shotcrete, are: greater density, greater uniformity, lesser permeability, lower shrinkage, less dependence on personal skills of equipment operators, less dust, less clean-up work, and more economical. The comparative disadvantages of these two methods are that all work on vertical surfaces requires formwork, and for extensive restoration the plant required could be considerably more expensive than that required for shotcrete placement.

Prepacked concrete entails placing coarse aggregate in the form and filling the voids in the aggregate mass with intrusion grout that consists of portland cement, a high grade pozzolan, sand, water and an intrusion aid. The intrusion aid is a chemical admixture that suspends the solid particles in the grout, provides fluidity at low W/C ratios, and undergoes slight expansion before final set. The volume of air entrained in the intrusion grout is about 9%. The amount in the

hardened concrete depends on the ratio of grout to coarse aggregate, but usually is about 4%. Bonding strengths of prepacked to regular concrete are between 70% and 100% of that attainable in regular concrete. This makes it possible to restore deteriorated concrete members to near their original strengths or to enlarge existing members to take additional loads.

Weakened material should be removed to expose sound concrete, and the surfaces of sound concrete should be roughened by either chipping or heavy sandblasting before repairing. Space must be provided for the replacement or addition of at least 3 to 4 inches of new prepacked concrete. Forms are then well-anchored to the old concrete, filled with coarse aggregate (of proper gradation for the thickness being placed), and the grout intruded. When the forms are filled, a closing pressure of about 10 psi is held for several minutes to drive out all air and water through a vent at the highest point. The forms are removed one or two days later, and the new concrete is properly cured.

3.4.6 TREMIE CONCRETE. One method of placing concrete underwater, especially at easily accessible locations, involves a tremie (a steel tube having a hopper for filling at its upper end). A plug, consisting of either a rubber ball or a wad of burlap that fits snugly inside the tremie, is inserted below a loading hopper located at the upper end of the tremie. The freshly mixed concrete, introduced at the hopper, forces the plug down and displaces the seawater. The tremie is continually replenished with concrete while the lower end is kept embedded in the newly deposited concrete. Tremie concrete must be quite workable so that it flows readily into place.

It is general practice to use a steel tremie, but a rigid rubber hose could be substituted. An aluminum alloy tremie should never be used because an adverse chemical reaction may occur to produce inferior concrete [3.5]

The size of the tremie depends on the maximum size of gravel and on the quantity of concrete to be emplaced; the usual range in diameter is from 8 to 18 inches. Records of underwater construction show rates of lineal flow between 3/4 and 1 foot per second. The slump of tremie concrete must be maintained between 6 and 7 inches.

3.4.7 PUMPED CONCRETE. Pumping freshly mixed concrete is the most expeditious means of placing concrete in spaces of limited accessibility. The pumping method offers several advantages: (1) High quality concrete is required because the mixture must be workable in order to pass through the pump; (2) Workable mixtures containing relatively small coarse aggregate particles tend to provide a dense concrete; (3) The pump pressure helps to coat the aggregate particles more uniformly and, thus, increase the density of the resultant concrete; (4) Concrete can be transferred from a barge directly into wooden forms at the patching site; and (5) Pumped concrete can be used to fill the forms from the bottom upwards, displacing the seawater as additional concrete is forced in at the bottom.

The pumping method also has some disadvantages: (1) The slump must be carefully controlled to prevent segregation as excessively wet mixtures will sometimes segregate; (2) Coarse aggregate should consist of rounded particles as crushed stone mixtures are comparatively difficult to

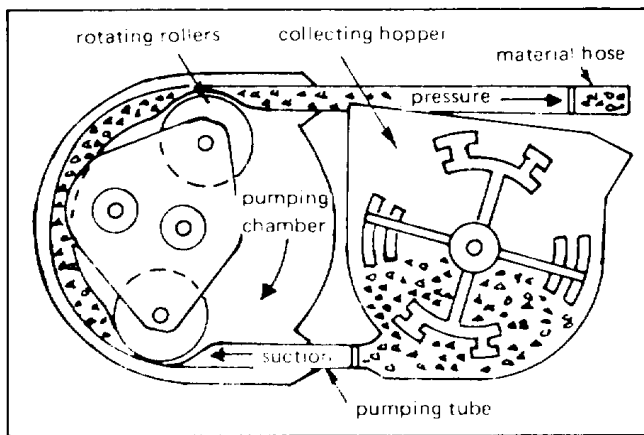

Figure 3-7. Typical squeeze-type concrete pump.

pump because the angular particles tend to interlock; and (3) Porous aggregates (e.g., expanded clay, foamed slag, pumice, and many corallin, materials) should be avoided, if denser aggregates are available.

The squeeze-type pump (Figure 3-7) is preferred for pumping freshly mixed concrete into the form because few of the pump parts contact the concrete. This pump is easy to clean and does not place the concrete under great pressure.

When air-entraining agents are required as described in 3.1.2.4, they are dissolved in the mixing water before it enters the concrete mixer. Quantities needed per bag of cement are specified by the manufacturer and are shown on the containers. Normally about 2 fluid ounces per bag of cement are used.

Water-reducing admixtures will also improve the pumpability of the concrete. If admixtures are used, do not decrease the cement composition; to do so would probably cause blockage in the pipeline. Pumping

air-entrained concrete will cause little reduction in air content.

The pipeline should be either horizontal or vertical rather than inclined, wherever possible. With an inclined pipeline any water bleeding from the freshly mixed concrete within the pipeline will collect above the concrete and run down the inside of the pipeline.

Delays as long as 1-1/2 hours can generally be tolerated if the mixture is moved several feet at least every 10 minutes (while in the hose or pipeline) until continuous pumping is resumed.

The concrete should be pumped as near to its final underwater position as possible. The diver who has control of the discharge end should not permit lateral flow within the open-top form of more than 2 or 3 feet. The discharge end of the line has to be buried in the mass of fresh concrete; otherwise, segregation will occur at the point where the concrete comes out. Aluminum pipe should not be used because an adverse chemical reaction with the concrete will occur. Rubber hose should only be used for discharge lines or for very short pumping distances. The pipeline should be protected from any excessive heat (solar included).

3.4.8 EPOXY RESIN. Cracks and joints in concrete waterfront structures must be sealed against the adverse effects of a marine environment as a means of prolonging the lives of such facilities. Various formulations of epoxy resin compounds are used for sealing, grouting, patching, and waterproofing cracks and joints in concrete, and as adhesives for bonding freshly mixed concrete or precast concrete to old concrete. No formulation can serve as an all-purpose material for these applications, and so each epoxy formulation should be used only for its intended purpose. Proper methods of treating the surfaces of concrete and

reinforcing steel preparatory to applying the epoxy compound, and correct procedures for using epoxy compounds are described in detail in References 3-6 through 3-8.

3.4.9 PROTECTIVE COATINGS. Coating hardened concrete surfaces (e.g., the decks of piers and wharves) with protective water repellents may be a good precautionary measure. A useful guide to coatings for protecting concrete is found in Reference 3-9.

CHAPTER 4 - STONE MASONRY STRUCTURES

SECTION 1. INTRODUCTION

4.1.1 BACKGROUND. Throughout the 19th century, stone masonry was generally used in constructing graving docks, quay walls, and wharves. As late as the 1850s, the cut stones of granite were set in lime mortar; after that, they were set in portland cement mortar.

4.1.2 DESIGN. In most instances the quarried and trimmed building stone used in graving docks is granite

(Figure 4-1). These structures usually incorporate massive gravity walls, the stability of which is a function of their mass. The designers of masonry waterfront structures specified greater mass, proportional to the expected loads, than is customary with mass concrete used today. Granite masonry usually develops no maintenance problems except at the joints.

SECTION 2. METHOD OF INSPECTION

4.2.1 VISUAL. The stone blocks in these old waterfront structures have been subjected to weathering, extraordinary loads, abrasion, and seawater. The best visual indication of how well they have resisted weathering is their general appearance. Blocks of high-quality stone retain their sharp edges and corners and their delicate tool marks for many years. After a century of service, these distinguishing attributes may no longer be present.

Empty graving docks should be inspected for leaking groundwater through the joints in their stone floors and sidewalls and for leaking seawater around the seals of the closure to the basin. All joints should be examined for cracks and erosion. The earth behind the sidewalls should be inspected periodically for settlement. Movement of the sidewalls of a graving dock or quaywalls is usually revealed by an increase in

width of cracks in adjacent paved areas atop the earth behind the walls. If leaks are detected, note the rate of discharge and whether or not material is suspended in the water. Divers should investigate for scour and undermining, especially outside the closure (Figure 4-2).

4.2.2 SETTLEMENT. If settlement of the structure is suspected, establish points for a level survey; locate these points on both sides of each suspected joint and at both ends of the masonry structure; these points should be related to permanent bench marks established previously by the U.S. Coast and Geodetic Survey. For a graving dock, these points should be located at the tops of the sidewalls, at the floor adjoining the sidewalls, along the longitudinal centerline of the floor, and along the outer rail of the crane track. Note any condition that could reveal settlement.

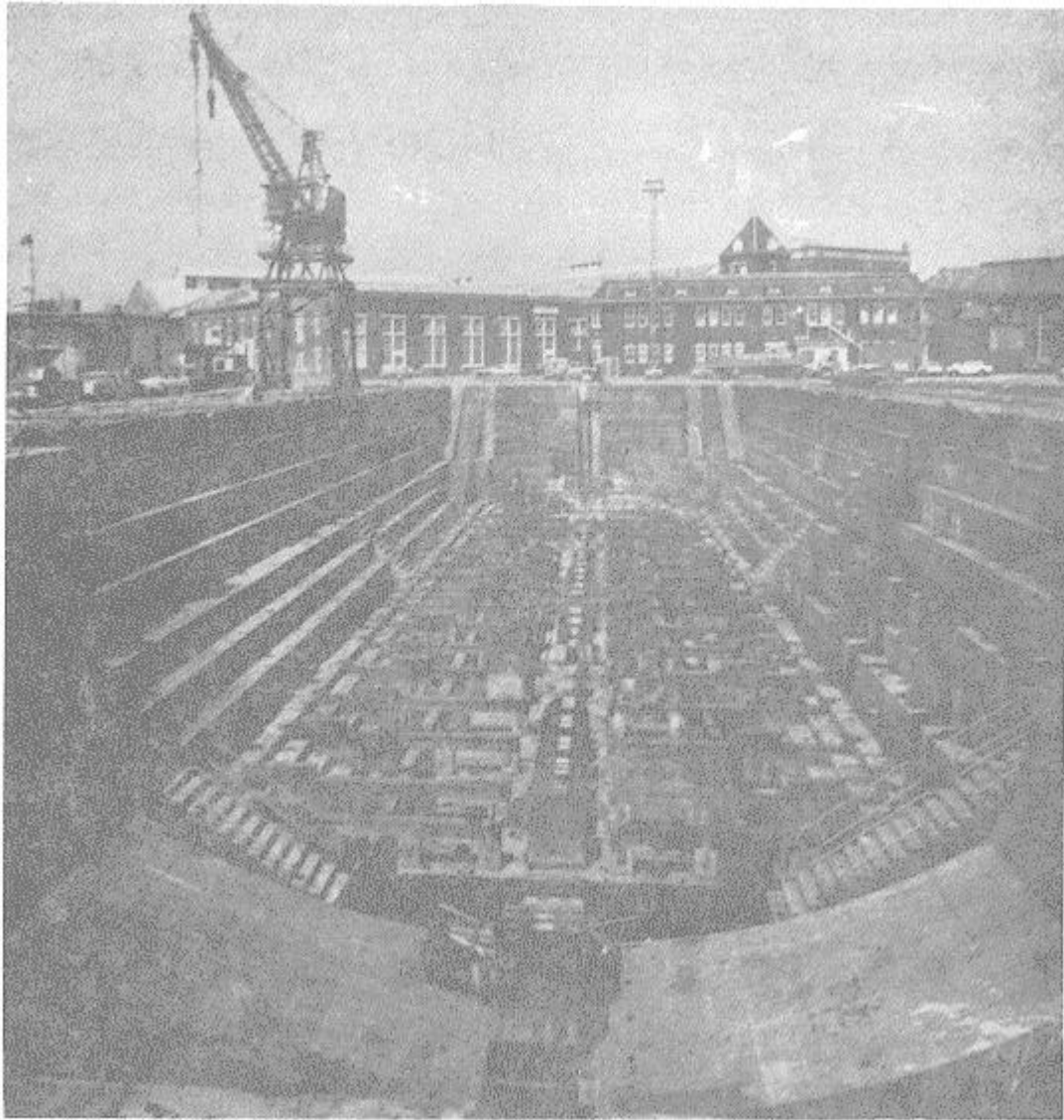

Figure 4-1. Masonry graving dock.

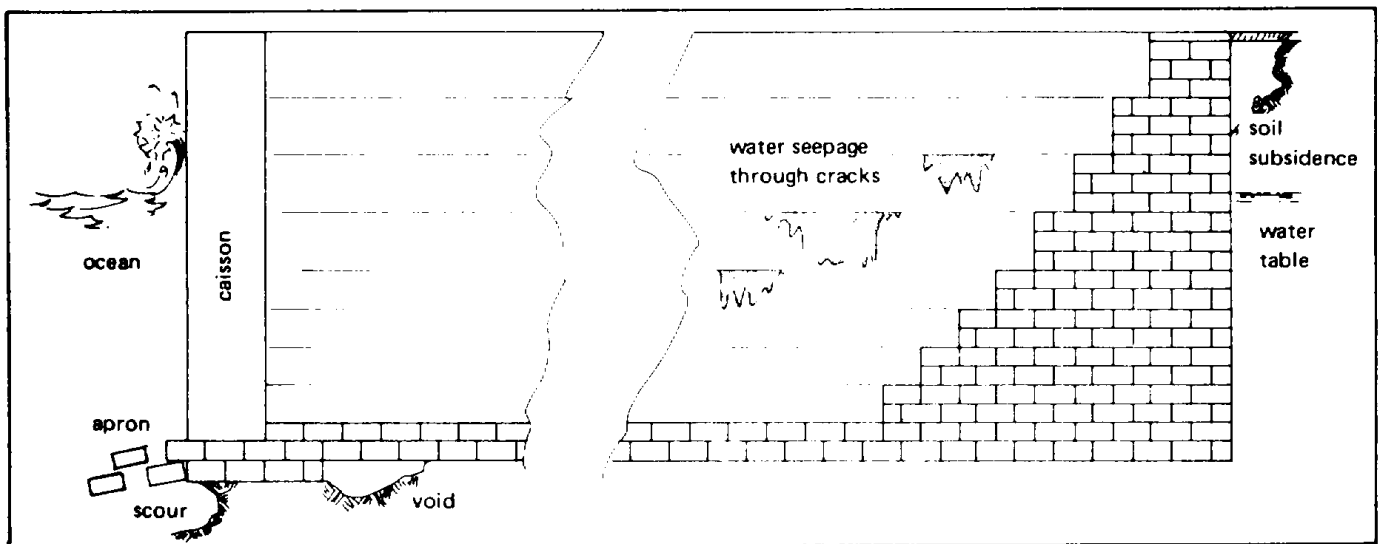

Figure 4-2. Types of deterioration that will require repair.

4.2.3 DOCUMENTATION. Periodically record and/or photograph cracks and related defects to ensure documentation of progressive failure; each photograph

should include the data and a scalar guide to enable the viewer to better understand the magnitude of the defect.

SECTION 3. METHODS OF REPAIR

4.3.1 ENGINEERING INVESTIGATION. If a masonry quaywall or graving dock has moved as the result of sliding at the foundation, a structural analysis to determine the cause is necessary before any restoration is attempted. An investigation of the settlement may involve pumping dyed water through cracked or leaky joints to determine the extent of hidden cavities or voids; the existence of a cavity would be confirmed by finding the colored water at some drainage outlet. After such an investigation has yielded the location, depth, and extent of the cavity or void, a program of grouting must be planned.

If any portion of the masonry structure is damaged, or if any stone blocks are loose, repairs should ensure that the bond between the blocks is restored. If a masonry quaywall or sidewall of a graving dock is cracked due to unequal settlement, restoration should be delayed until the cause of settlement has been corrected.

4.3.2 WEEP HOLES. If there is evidence that water is collecting behind the quaywall, and if weep holes are part of the installation, the holes should be cleared to allow drainage. If this procedure is insufficient to relieve the pressure, additional weep holes should be drilled.

4.3.3 SHRINKAGE CRACKS. Shrinkage cracks in joint mortar appear as hairline cracks; they are usually found

in vertical joints. If the masonry exhibits signs of leakage, hairline cracking can also be present in the horizontal beds of mortar. Spalled mortar can be caused by many cycles of alternate freezing and thawing.

4.3.4 TUCK-POINTING. Defective joints can usually be repaired by tuck-pointing with portland cement mortar; a skilled stone mason is required. Tuck-pointing only the obviously defective joints does not ensure that the untreated joints will not leak; therefore all joints, vertical and horizontal, in the face of the wall should be tuck-pointed. This procedure requires removing and replacing all mortar to a depth of at least 5/8 inch throughout every joint. Each joint is raked to a depth not greater than 1 inch, unless the old mortar is so defective that removal to a greater depth is necessary. The depth of old mortar removed should be such that sound mortar will serve as the base for the new mortar. All exposed sound mortar must have a clean, square-cut surface. All dust and dirt within the raked joint should be washed out by a jet of water. Wherever old mortar is raked out deeper than 1 inch, the hollow spots must be filled with new mortar first so that a uniform line is created. The cleaned joints are tuck-pointed with the portland cement mortar while the masonry is still damp (not wet) from washing out the raked joints.

The mortar is mixed at least 1 hour before use to ensure prehydration, which stabilizes the plasticity and workability of the mortar and minimizes any tendency to shrink after insertion into the joint opening. A suitable mortar incorporates a special masonry cement (Type II portland cement and a plasticizer), silica sand, and freshwater. It has a somewhat stiff consistency to enable it to be tightly packed into place. The sand/cement ratio should be about 3 to 1 by volume. Placement should be done as follows:

- (1) Insert a base layer 3/16 to 1/4 inch thick
- (2) Insert the second layer when the base is sufficiently set so that no fingerprint can be made (use a sample representative of the first layer)
- (3) Allow the second layer to set for several hours before the joint is finally packed to its full depth and tooled at the face

After tuck-pointing, the masonry should be maintained in a damp (not wet) condition for at least 72 hours. Note: modern epoxy-based materials should be permitted as an alternative to portland cement mortar.

4.3.5 GROUTING. Leaky stone masonry structures can be sealed effectively with less cost by using grout,

provided the cement-base stabilizing mixture contains an intrusion aid. The consistency of the intrusion mixture is that of a smooth slurry. This mixture is pumped into holes previously drilled at various intervals to various depths without damaging the integrity of the structure. Before the intrusion grout is pumped, the holes are tested by pumping water to see if the drilling is adequate and to determine the correct consistency for the slurry repairs. Technical details relative to portland cement grouting are given in Reference 4-1.

Details for the use of portland cement grout in reducing leakage by more than 90% in a gravity-type dam of rubble masonry faced with ashlar are described in Reference 4-2. It is shown that (1) isolated grouting tends to hinder the flow of grout injected later through adjacent drill holes, and (2) pumping the grout simultaneously into a multiple series of drill holes ensures good penetration into any fissures within the structure.

The pressurized injection of latex silicate, a method of grouting developed during the 1960s, has been successfully used in England for making masonry structures watertight [4-3].

CHAPTER 5 - RUBBLE-MOUND STRUCTURES

SECTION 1. STRUCTURAL COMPONENTS

5.1.1 MOUND. A mound is an artificial embankment or ridge composed of sand, gravel, and cobbles, constructed on the oceanic floor by dumping the material from scows and barges. The dumping operation continues until the mound emerges a certain distance above the mean seawater level. Wave action on the mound gives the sides a natural stable slope. Since wave action decreases as the oceanic depth increases, the natural side slopes of the mound normally are steeper in deeper water; this is a function of top elevation of the mound, bottom configuration, and tidal range. Rubble-mound structures are used extensively, because they are adaptable to most any depth of water in the vicinity of harbors and can be repaired readily. If the oceanic floor is not rocky, rubble can protect the floor against scouring that otherwise might occur at the foot of the mound.

5.1.2 RUBBLE. Rubble is irregularly shaped, rough stones, ranging in size up to 1,000 cubic feet each and in weight up to nearly 90 tons each. The stones are in the same condition as when quarried but without any preparation (i.e., dressing) other than removing very sharp angles and any objectionable protruding points. Hard rock, which is more desirable, usually consists of either granite or traprock (fine-grained igneous rock). Limestone, dolomite, and sandstone are undesirable because of their lesser hardness, toughness, and durability.

Since the rubble used as riprap must be available in large sizes, the quality, condition, and shape of stone are important. Each piece should be devoid of planes of weakness, have a specific gravity not less than 2.6, and have excellent resistance to abrasion and weathering. Massive, compact, fine-grained igneous rock is the best source of rubble.

5.1.3 RIPRAP. Riprap is a mixed assemblage of rubble, either dumped indiscriminately (as a foundation for the waterfront structure) from scows and barges or deposited on the surface of a mound to protect the mound against erosion by waves and scouring by tidal action and underwater currents. Where it can be procured in large quantities at low cost, riprap can be useful as a filter blanket over a sandy bottom, as fill behind moles and quaywalls, and as protection for the sloping sides of mounds. Riprap submerged en masse weighs no more than earthen fill and rests at a steeper slope (approximately 1-1/4 to 1) than does earth.

The riprap in older breakwaters consists of large cubical or rectilinear blocks of quarried stone. Since 1950, a number of precast concrete armor units have been developed; the prevalent types are tetrapods, tribars, and dolosse (Figure 5-1). Smaller concrete armor units can often be substituted for larger quarry stones and still obtain comparable protection of the

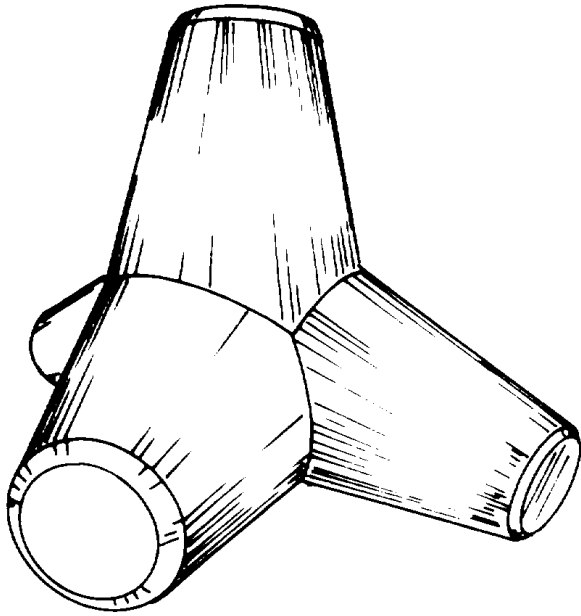

(a) Tetrapod.

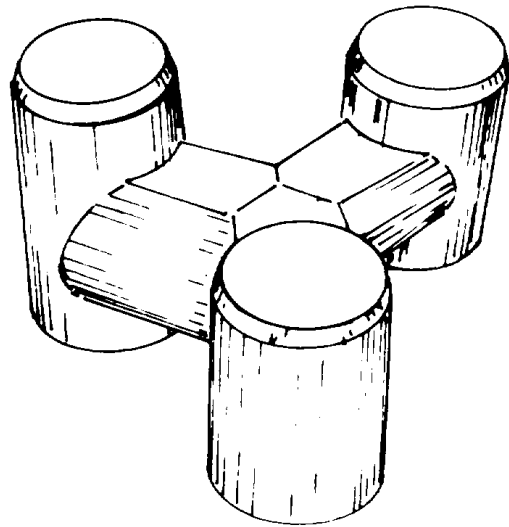

(b) Tribar.

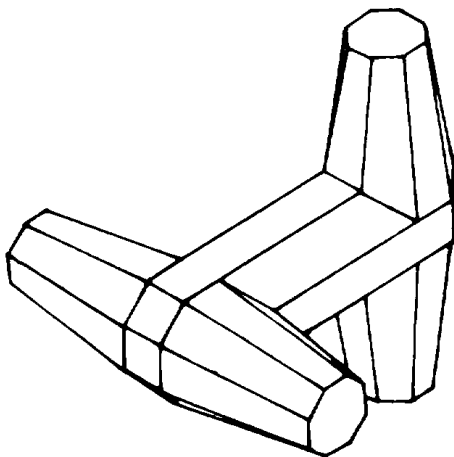

(c) Dolos.

Figure 5-1. Concrete armor units.

mound of rubble. No reinforcing steel or steel lifting eyes are used in dolosse and tetrapods; consequently, corrosion is not a problem, and unit cost is minimized. Dolos and tetrapod units are less vulnerable to damage

during placement and storms than the various other types of concrete armor units. The Army Engineer Waterways Experiment Station considers the dolos armor unit the most efficient [5-1].

SECTION 2. CAUSES AND TYPES OF DETERIORATION

5.2.1 TYPES OF DAMAGE. The three principal types of deterioration in rubblemound structures are: (1) sloughing of side slope in the riprap, (2) slippage of base material as the result of scour by offshore currents, and (3) dislodgment of stones, especially capstones covering the crown of the structure, from their original position as the result of intense wave action.

Scour at or near the base of a rubblemound structure does not normally occur if the structure is correctly designed and the floor is stabilized by means of a properly designed filter blanket and ample riprap. However, if one or more groins should be subsequently installed at incorrect locations nearby, then radical changes in currents and their velocities could adversely influence the base of the structure.

5.2.2 STRUCTURAL DAMAGE.

5.2.2.1 Seawall. A seawall can suffer loss of riprap; this successively leads to erosion, by subsequent wave action, of the toe of the structure and later to undermining of the base.

5.2.2.2 Groin. Correctly designed, located, and constructed groins seldom undergo damage by wave action, because the littoral drift tends to fortify the structures (Figure 5-2). Ideally, the shoreline remains stable as long as the rates of deposit and erosion are equal. If the erosion rate the deposition rate, the shore decreases in area, and the groin is then subjected to gradual destruction.

5.2.2.3 Breakwater. Breakwaters are often subjected to extreme wave action that dislodges riprap and washes out portions of the mound. During violent storms, sections of a breakwater can occasionally be broken through. A typical rubble-mound breakwater is shown in Figure 5-3.

5.2.2.4 Jetty. Jetties are designed to direct the flow of currents and tides through the entrance channel so as to ensure a minimum velocity. Though to all outward appearances they may be satisfactorily sustaining the pressure, the flowing water can gradually scour the base material on the channel side and eventually cause either subsidence of a portion of the jetty or sloughing of the riprap comprising the side slopes.

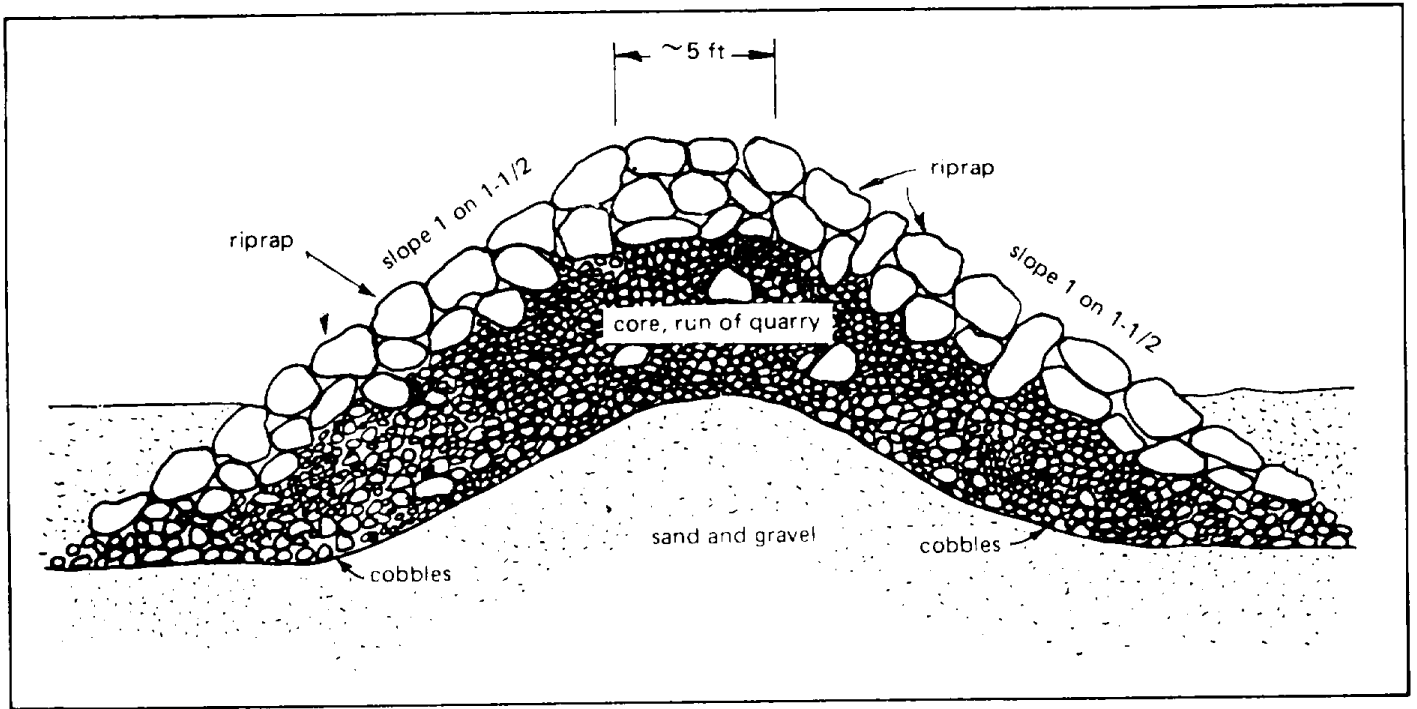

Figure 5-2. Cross section of semipermeable rubble-mound groin.

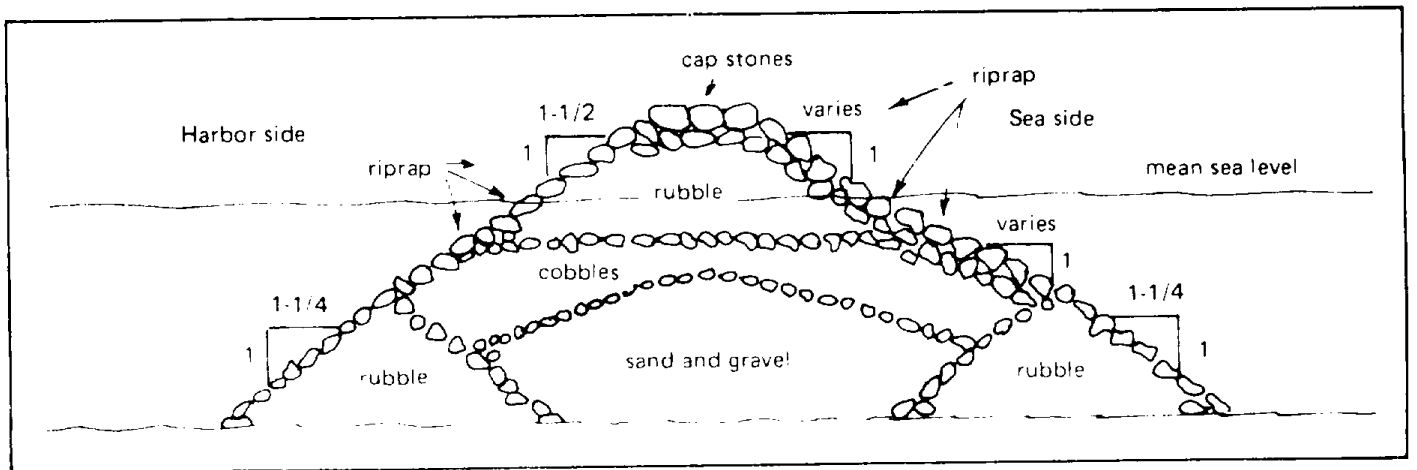

Figure 5-3. Rubble-mound breakwater.

SECTION 3. INSPECTION

Rubble-mound structures are always subjected to wave action and, consequently, to deterioration. The inspection should provide for detecting beginning weaknesses in the bases of these structures (e.g., washout of small stones in the riprap and any core material in the mound).

5.3.1 COMPONENTS. The crown of a rubble-mound structure is inspected visually on foot; the portions above water level are inspected visually from a dinghy or small craft; and the portions below the water line are inspected by divers or underwater TV cameras. The intended depth of the structure is determined from the design drawings; the as-built depth should be compared with depth data obtained by soundings taken at stations that are located at equidistant intervals. As much of the structure as possible should be inspected at low tide. If scouring or sloughing is apparent an engineering investigation should be initiated. The inspection by the divers when tidal conditions and wave actions permit may be able to verify the indicated deficiency or damage. Underwater television can be effective as a visual means of inspection, but is frequently negated by turbulence, suspended sediment, or inability of the

operator at the surface to maneuver the apparatus readily.

5.3.2 DRAINAGE. A rubble-mound mole requires proper drainage of backfill to prevent a pressure differential. Visual inspection of the surface of the backfill will reveal any discrepancies concerning drainage. Dredging alongside a rubble-mound mole must be restricted to depths not greater than contemplated in the original design. If any portion of the base becomes undermined (e.g., dredging too closely to the riprap) the structure is likely to slip and fail. If the backfill in either a mole or seawall shows evidence of settling (e.g., cracking and cave-in of paved surface) as illustrated in Figure 5-4, the condition of the backfill should be investigated to determine whether or not either improper surface drainage or loss of backfill through the riprap is the cause. Stabilization of the backfill, either by replacing the lost fill with properly graded material in the filter blanket and in the core or by careful grouting, may correct the problem (see Chapter 6). After stabilizing the backfill, all defective pavements should be repaired to prevent any erosion of the underlying backfill.

SECTION 4. METHODS OF REPAIR

5.4.1 AS-BUILT DRAWINGS. Drawings showing the construction as actually built, rather than as originally designed, should be used in preparing plans for repair of rubble-mound structures. All drawings and records pertaining to any previous repairs should be reviewed

before undertaking new repairs.

5.4.2 REPLACING COMPONENTS. Maintenance on rubble-mound breakwaters is greater than on any of the other types. Proper grading of the seaward slope and



Figure 5-4. Cave-in, indicating settlement of mole.

use of the correct classes of stone for core and capping will, to a great extent, minimize the amount of annual maintenance required. Any material lost through scouring and washing must be replaced periodically with materials of the same kind and size as used originally. Adjustments in seaward slope may be necessary. Material should not be replaced to the original slope if investigation shows that a change is in order. A change in the type of capping material also may be necessary with the passage of time, and use of concrete tetrapod, tribar, or dolos armor units may improve the structure. If large facing and capping stones are set in a tight

pattern, the vertical joints between the stones may need venting (by leveling the corners of individual stones) to permit entrapped air and water to escape. This reduces the lifting action beneath the stones and improves their stability.

The replacement of riprap (after replacement of any material washed out of the mound) should either retard or prevent further scouring. If the scour is produced only by wave action, the problem can be solved by fortifying the toe of the structure with a thick

layer of riprap which serves to stabilize the bottom; the rubble must be carefully emplaced so that the smaller stones become wedged in the spaces between the larger stones. Units weighing less than 1 ton each should constitute about 15% (by weight) of the additional riprap, and the maximum weight of each of the larger stones should approximate 3 tons. The minimum dimension of any stone should be at least one-third of its maximum dimension.

If the scour is caused by offshore underwater currents, installation of groins at strategic locations along the shoreline may be necessary. If the bottom is scoured so extensively that the stability of the structure is endangered, an underwater groin consisting of very

heavy rubble may be effective in deflecting the underwater current; in such an installation, the groin is designed to accumulate waterborne material so that the floor around the foot of the structure builds up and serves as a stabilizing influence.

Rubble-mound breakwaters, jetties, and seawalls occasionally are repaired by adding crushed stone to the crowns and seaward slopes and grouting the new surfaces. Repairs of this type, which must be made in stages because of tides, must produce a thick (3 feet or more) protective layer or blanket of grouted stone. Figure 5-5 illustrates the general scheme of repairs.

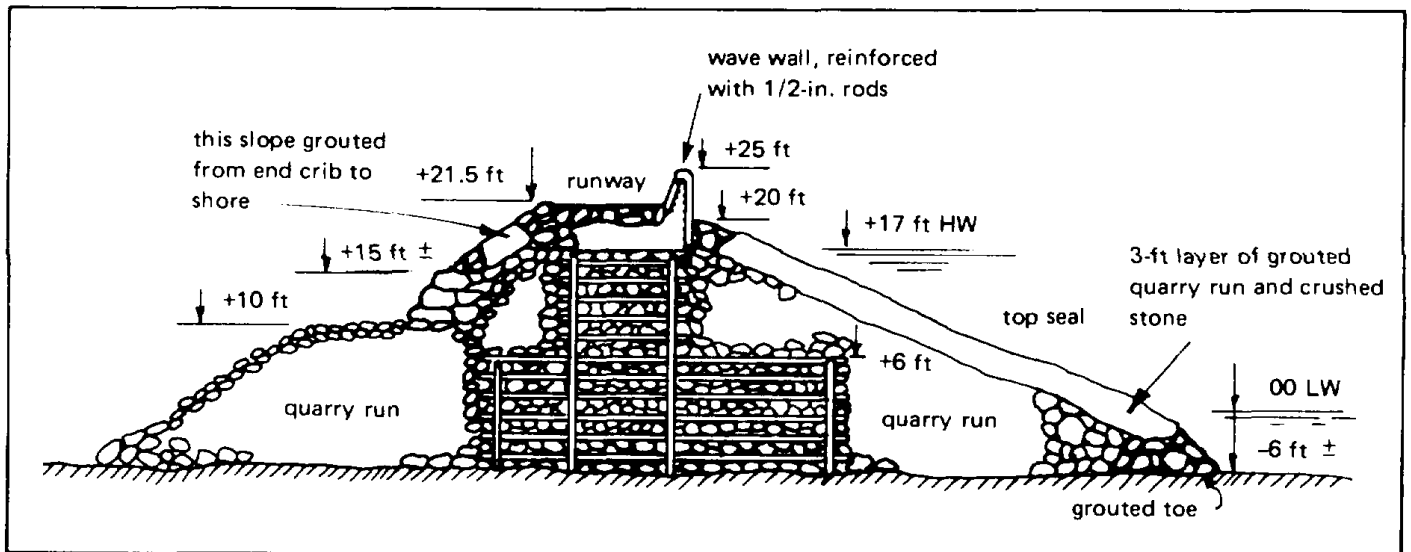

Figure 5-5. The grouted sheathing of face of a breakwater, which is exposed to storms.

CHAPTER 6- STRUCTURES INVOLVING SOIL

SECTION 1. SOIL DESCRIPTION

6.1.1 WATERFRONT USE. Earthworks, consisting of soil materials generally enclosed within a protective covering of coarse stone riprap, steel, or concrete skins, are used for waterfront structures, such as dikes, levees, breakwaters, causeways, groins, and seawalls. Soil generally provides the backfill for quaywalls, caissons, and other cellular structures. The most common cause of deterioration and damage to such structures is erosion of the soil by water movements, generally due to wind, tidal, or wave action (References 1-2 and 1-3). Any breaching of or impairment to an earth structure exposed to moving water sharply increases its susceptibility to damage. For this reason it is very critical that any required maintenance be identified and carried out as quickly as possible.

6.1.2 DEFINITION. Soil is composed of particles that differ physically in size and shape and vary in chemical composition. Organic matter, water, air, and bacteria are usually present, but soil consists essentially of mineral matter that has originated from rocks by the action of a series of weathering processes.

6.1.3 SOIL CLASSIFICATION. The complete description of a soil includes: (1) its classification according to the Unified Soil Classification System (see

Reference 1-10, Chapter 1, and/or References 6-1, 6-2, or 6-3); (2) its in-situ state, such as structure, density, shear strength, moisture content, etc.; and (3) its mineralogic content. With reference to soils used in waterfront structures it is often sufficient to classify them only according to size (i.e., clay, silt, sand, and gravel). The density, plasticity, and moisture content are most important for the finer-grained soils, while soundness and gradation are most pertinent to the coarser-grained soils and rock fills. The particle size, which marks the boundary between the fine-grained, generally cohesive soils (silts and clays) and the coarse-grained, granular soils (sands and gravels), is approximately the smallest sized particle that is large enough to be individually discernible to the naked eye. This is the minimum size retained on the no. 200 standard sieve (about 0.07 mm in diameter). For the fine-grained materials the Atterberg Limits (ASTM D424 [6-4], D423 [6-5], and D427 [6-6]) are very important as are the moisture contents. Organic soils, such as elastic silts and peats, are never used in the construction or repair of engineering structures, and, therefore, will not be considered herein.

SECTION 2. SOIL PLACEMENT

6.2.1 TYPES OF SOIL. Although most types of inorganic soil materials have been used for waterfront structures, the problems experienced with regard to placement, maintenance, and protection of the fill generally increase markedly as the grain size diminishes. Finer-grained soils in the cohesionless range are extremely susceptible to leaching and erosion, whereas fine-grained cohesive soils are more difficult to compact satisfactorily and may undergo undesirable shrinkage and/or swelling behavior. With granular soils, gradation (i.e., distribution of the various sizes) is important. Uniformly graded soils with a narrow range of particle sizes are difficult to compact, are extremely porous, and obtain lower densities and strengths than soils with a broader distribution of particle sizes. However, where compaction of sands and gravels is involved, the presence of large, oversize cobbles can interfere with the compaction of the finer materials present. Such larger particles can be excluded from the compacted fills and used as riprap or slope protection.

6.2.2 COMPACTION CONTROL. The performance of soil embankments improves with density; thus, soil fill materials should generally be placed at as high a density as is economically feasible, particularly with the finer-grained soils. There is a particular moisture content for a particular soil at which the maximum density is obtained under a specific compaction effort. Thus, moisture control is an important factor toward efficient compaction techniques, particularly with silts, clays, and mixed soils.

The two most common standards for compaction control are the standard Procter (ASTM D-698-58T) [6-7] and the modified Procter (ASTM D-1557-

58T) [6-8] tests. The latter method represents a larger compactive effort than the former and has been adopted to account for the higher compactive efforts of current construction equipment. However, the standard considered most pertinent for waterfront structures is still Procter. This is because the lower compactive effort results in a slightly higher optimum moisture content for maximum density, and the higher moisture content is more compatible with the expected in-service conditions of waterfront structures.

A typical requirement for many waterfront structures is to specify a compacted density of 95% of standard Procter, but this may vary with the type of structure and its present condition. It is generally desirable to place a soil material in a structure in as close to its long-term stable condition as possible. Although clean, granular materials should be placed in as saturated a condition as is practicable, fine-grained or mix-grained soils may require moisture contents to be maintained within a particular optimum range. Often, control of water content with respect to the optimum value is left up to the discretion of the contractor, since he can elect to replace rigorous moisture control with increased compactive effort. In cases where excess compactive effort could result in damage to the structure, such as in quaywalls or cofferdams, the compactive effort should be minimized and the moisture content should be controlled as well as is practicable. For these latter types of structures it is also very important that design densities not be exceeded. Excessive compaction might result in undesirable lateral stresses in structural members.

6.2.3 TYPES OF COMPACTION. The type of compaction selected should be based upon the soil type. Vibratory compaction is most efficient with granular soils, whereas kneading types of equipment, such as sheepsfoot rollers, are more applicable to cohesive soils. There is no ready means of controlling the compaction of coarse rock fill. Vibratory rubber-tired compactors in the 12-to-15-ton range are reasonably effective for all types of soil. Soil lift thicknesses should generally be limited to soil layers having a compacted

thickness of no more than 6 inches, except in cases where it has been demonstrated that the compactors are capable of achieving the required densities throughout the full depth of thicker lifts. Such a situation might exist with a vibratory compactor on relatively clean, cohesionless material. For backfilling sheet pile cofferdams or other structures of limited extent, it may be necessary to use small hand-operated tampers or compactors. The importance of compaction generally increases with decrease in grain size.

SECTION 3. INSPECTION

Inspection of waterfront soil structures is generally limited to visual observations. In some cases piezometers, survey stations, or other devices may be installed into the structure to facilitate inspection. Unfortunately, the corrosive nature of the waterfront environment inhibits the long-term performance of most permanently installed instrumentation. Pressure-relieved structures, such as some drydocks, are susceptible to destructive uplift pressures due to failure of the dewatering system, development of erosion channels, or deterioration of flow cut-offs, etc. Regular monitoring of pore pressure levels beneath the structure must be carried out and reference made to the design

level. In cases where damage is noted or suspected (such as the observance of escaping backfill at the toe of a wall, the presence of sediment in the seepage water, or surface slumping), other techniques, such as drilling exploratory boreholes or using sonic or geophysical techniques, should be resorted to (see Reference 1-10, Chapter 2). A number of sophisticated nondestructive testing techniques, such as those using reflected electromagnetic waves, are occasionally suggested, but the nature of the waterfront, particularly the salty ocean environment, drastically impairs the value of such methods.

SECTION 4. REPAIR

6.4.1 EROSION. The major maintenance requirement for earth-filled waterfront structures consists of preventing the soil from being eroded and replacing the soil when a loss is discovered. This means maintaining

sufficient riprap or slope protection on side slopes or insuring the integrity of soil-containing structures, such as sheet pile cofferdams, timber or concrete paneled quaywalls, etc. In cases where there is evidence of

erosion or loss of soil, any protective covering, such as rockfill or armor units, should be removed, and the internal fill material inspected. Any necessary repairs in the form of replacement of properly compacted soil should be made, and the protective slope covering replaced in a manner to insure no further erosion. This may require a series of soil layers of varying coarseness to insure that the finer, central materials cannot be washed out through the coarser, shell materials. In some cases it may be desirable to protect the side slopes of the structure by such means as asphaltic concrete, soil cement, or even reinforced portland cement concrete. In cases where the side slopes are exposed only to atmospheric erosion, vegetation such as ice plant, grasses, etc., might be adequate.

6.4.2 SEALING. The loss of soil from behind quaywalls or from within sheet pile cofferdams, etc., requires sealing of the structure to prevent further loss of material and replacement of suitable backfill. Coarsergrained materials are generally preferred where they are available, since they are less subject to leaching or erosion. Fine-grained materials are desirable only where very low permeability is required, such as in the core of an earth dam. In such cases precautions, such as the construction of inverted filters or sealing of structural joints, etc., are necessary to prevent the erosion of fines. Since surface water (such as rainfall) can contribute greatly to erosion, provision should be made for the disposal of runoff. Where materials consist of the very erodable silts or fine sands, the structure must be sealed to prevent any influx of surface water.

6.4.3 DEWATERING. Where excavation and replacement of soil takes place below the water table, it may be necessary to dewater the site by use of seepage

barriers, such as sheet piles. Where soil permeabilities are greater than 1×10^{-3} fpm, subsurface drainage by well points, deep wells, etc., may be necessary (see Reference 1-10, Chapter 8). Prior to planning dewatering procedures it is necessary to determine permeability and piezometric levels by field observations (see Reference 1-10, Chapter 4). The major criterion is to avoid instability through piping or heaving. This is achieved by controlling the upward hydraulic gradient at the base of the excavation. Hydraulic gradients (head loss per unit length of flowpath) of one lead to immediate instability in all cases, but exit gradients of 0.5 to 0.75 will cause unstable working conditions even in clean sands. Silty materials are even more critical.

6.4.4 GROUTING. In some cases it may be more expedient to either seal or repair a damaged structure by injecting grout (see Reference 1-10, Chapter 15, or Reference 6-9). Grout may be used to reduce the permeability of the soil fill or its foundation and, thereby, minimize erosion or leaching. It may also be used to physically strengthen the structure to make it better able to resist wave or ship loadings, superimposed dead loads, etc.

Cavities or voids in the soil structure may be grouted using sand/water mixtures, portland cement, clay, chemical grouts, or a combination of these materials. Sand/water mixtures are applicable only where large cavities are present and the paths of soil loss have been sealed off. Cement grout is not considered applicable if the effective grain size of the in-

place soils, D_{10} (the sieve size through which only 10% of the soil would pass), is less than 0.5 mm for loose soils and 1.4 mm for dense soils. Thus, portland cement grout is most applicable to the situation where the grout can be pumped directly into cavities.

An effective grouting procedure for sandy materials consists of injecting solutions of sodium silicate and calcium chloride. This procedure both

solidifies and impermeabilizes the soil, but it is extremely expensive. Mixtures of cement and clay are also used, sometimes with the addition of a chemical deflocculent. One of the more recently developed chemical grouts polymerizes in the soil voids; however, it is also expensive. With fine-grained backfills, grouting is generally of no benefit except to fill cavities or to seal off paths of soil removal.

CHAPTER 7 - STEEL STRUCTURES

SECTION 1. CORROSION

Structural steel is used in most metal waterfront structures because it is strong, readily available, easily fabricated, and not excessively costly. Cast or fabricated steel is normally used for such accessories as bitts, bollards, cleats, and chocks. Other metals have specialized uses because of unique properties, such as being lightweight (e.g., aluminum) or corrosion resistant (e.g., monel).

7.1.1 DEFINITION OF CORROSION. Corrosion is the destruction of a metal by its reaction with the environment. This reaction is an electrochemical oxidation process that usually produces rust or other metal oxide. A more lengthy description of corrosion and the corrosion process can be found in References 7-1 and 7-2.

Since corrosion is an electrochemical process, it

requires an electrolyte or current-carrying medium between different parts of the corrosion cell. In marine submerged areas, seawater is the electrolyte; in marine atmospheric areas, salt spray provides the electrolyte. Oxygen greatly accelerates corrosion, which accounts for the rapid corrosion that takes place in the splash-zone area of waterfront structures where both seawater and oxygen are in abundance. Like most spontaneous chemical reactions, corrosion increases with increasing temperature.

7.1.2 TYPES OF MARINE CORROSION. There are many types of marine corrosion that can occur to steel waterfront structures and many methods for corrosion control. In actual practice, these methods are combined in an overall corrosion control program. The most common types of metal corrosion occurring in a marine environment are described in Table 7-1.

SECTION 2. PROTECTIVE COATINGS

7.2.1 PROTECTION. The chief means by which protective coatings impart protection to steel is by providing a barrier between the metal and the environment that is necessary for corrosion to occur. In all cases the coating must be free of pinholes or other discontinuities and of sufficient thickness to prevent the environment from reaching the metal. Certain corrosion

inhibitive pigments (e.g., chromate salts and red lead) when properly formulated in a primer pigment can deter corrosion should there be a break in the coating barrier.

Reference 7-3 presents a comprehensive coverage of paints and protective coatings.

Table 7-1. Types of Corrosion

Type	Description	Remarks
Galvanic Corrosion	Two dissimilar metals connected to each other electrically in an electrolyte (e.g., seawater). Current flows through the electrolyte from the more reactive metal (the anode) to the less reactive metal (the cathode), thereby corroding the anode area while protecting the cathode area from corrosion,	<ol style="list-style-type: none"> 1. New steel is anodic to old steel. 2. Brightly cut surfaces (e.g., pipe threads) are anodic to uncut surfaces. 3. Steel is anodic to its surface mill scale. 4. Highly stressed areas (e.g., pipe bends) are anodic to less stressed areas.
Stray Current	Occurs on metal surfaces wherever stray direct current passes from them to an electrolyte. This current most frequently arises from electric railway and crane systems, improperly grounded welding generators, and adjacent cathodic protection systems.	Stray current corrosion should always be suspected as the cause of accelerated corrosion in areas adjacent to sources of DC current and checked for by detection of current flow.
Differential Environmental	Occurs from differences in chemical composition of the medium. Usually results from different levels of aeration (oxygen content); less frequently from different salinities	Corrosion occurs in area of lower oxygen content. On steel piling, this is just below the mean low tide level. Also in crevices and corners because less oxygen is there.
Erosion-Corrosion	Scouring action of sand and other abrasives exposes bright metal and keeps the corrosion active	<ol style="list-style-type: none"> 1. Commonly found at or just above the mud line on steel piling or riser chains of moorings. 2. Wind in sandy areas.
Biological Corrosion	Marine biological organisms accelerate corrosion by changing the normal environment	<ol style="list-style-type: none"> 1. Organisms may create different oxygen levels in the electrolyte. 2. Organisms may create corrosive products through their metabolism or decomposition. 3. Organisms may remove the protective film of corrosion products from metal surfaces.

7.2.2 SURFACE PREPARATION. The proper preparation of steel surfaces prior to coating is essential for maximum coating life and protection of the steel. The selection of the type of surface preparation depends upon the type of paint used, the condition of the surface to be painted, economic considerations, and such practical limitations as time, location, accessibility, and availability of equipment. Standards for surface preparation are found in References 7-4 and 7-5.

Dry abrasive blasting of steel is generally necessary for optimum performance of modern synthetic coatings. It removes mill scale, rust, corrosive salts, and other foreign matter that is detrimental to good coating application and imparts an anchor pattern (tooth) to the steel to which the coating can bond tightly.

Many local air pollution control agencies may restrict dry abrasive blasting because of the dust emitted during operation. The addition of water to the abrasive may be necessary to meet the air pollution control regulations. In such an event, a rust inhibitor needs to be added to the water to prevent rusting before paint application.

Waterblasting of steel without an abrasive may provide a clean surface for re-painting without requiring an abrasive-blast finish. Wire brushing, either manually or with power equipment, can in some cases provide an adequate steel surface for painting.

7.2.3 RECOMMENDED COATINGS. Coal tar coatings are frequently used on steel waterfront structures. Since they are relatively soft, their effectiveness in waters where barnacle fouling is heavy may be limited. Coal tar epoxy coatings are tough, durable, and very impermeable to water; thus, such coatings as Steel

Structures Painting Council Paint Specification No. 16 [7-6] have had many years of excellent service. Epoxypolyamide coatings, such as MIL-P-24441, have provided many years of excellent protection to steel waterfront structures, too. Zinc inorganic coatings, such as in Class 3 of MILP-23236, have been used successfully on the atmospheric portions of steel offshore platforms and waterfront structures [7-7]. They must be top-coated with an organic coating for long-term performance in seawater. Vinyl resin paints, such as VR-3 and VR-6 of the Bureau of Reclamation, perform well on steel. Petrolatum-coated tapes [7-8] have been used successfully to protect steel utility lines under piers. They can be applied to wire-brushed as well as abrasive-blasted surfaces. The encapsulation of steel piling with PVC wraps has been reported [7-9] to impart long-term protection from corrosion by producing an oxygen deficient environment.

7.2.4 COATING APPLICATION. In a marine atmosphere, conventional spray, roller, or brush application may be appropriate, as recommended by the coating specification or supplier. A coal tar coating is an economical choice in an atmospheric area where the black color is acceptable.

Application of coatings between tides may be made by spray, roller, or brush, but the coating must be one that will be unaffected by water and will cure under it. Steel Structures Painting Council Paint Specification No. 16 and MIL-P-24441 are two such coatings.

Two different types of coatings are available for application underwater [7-10]. One is a thick putty-like material that is applied by the palm of the hand, and the

other is a lower viscosity material that can be applied by brush or roller.

7.2.5 INSPECTION OF COATING. Protective coatings should be inspected at the time of application to make certain that all application requirements have been met. Appendix A of Reference 7-11 is a general guide to inspection of facilities maintenance painting. Visual inspection of coatings before, during, and after application can be effective in detecting deficiencies in the materials, surface preparation, or coating application. If deficiencies in the coating material are suspected, then laboratory testing should be done on paint from unopened cans to verify them. The film

thickness of protective coatings is very important because it is directly related to barrier protection. Measurement of both wet and dry film thickness is described in CEL Techdata Sheet 74-11 [7-12].

Coatings on metal surfaces should be checked for holidays, pinholes, or other discontinuities using one of the commercially available holiday detectors. A low-voltage detector (e.g., 50 to 60 volts) is ordinarily used on thin films (i.e., 12 mils or less), and a high-voltage detector (e.g., 10,000 volts) on thicker coatings. The coating must be free of water before the detector is used. Any localized damage to the coating by a high-voltage detector must be repaired.

SECTION 3. CATHODIC PROTECTION

7.3.1 DEFINITION. Cathodic protection is a system for controlling corrosion of a metal surface by passing sufficient direct current onto it to make it a cathode, thus eliminating the possibility of anodic loss of metal. The electrolyte for cathodic protection is usually soil or water. References 7-13 and 7-14 present a detailed description of cathodic protection of buried structures. Thus, discussion of cathodic protection in the present manual will be largely limited to structures in water. In the maintenance of waterfront structures it must be remembered that cathodic protection can prevent corrosion of a new structure or stop corrosion on an existing structure, but it cannot replace metal lost by corrosion of an existing structure.

7.3.2 TYPES OF SYSTEMS. There are two basic systems for supplying the necessary direct current electrical energy to a structure to cause it to become a cathode. The galvanic anode system requires no

external power supply, but incorporates anodes of a special alloy that generate the necessary direct current by virtue of a natural voltage difference from the protected structure (Figure 7-1). The galvanic anodes (also known as "sacrificial") are consumed, like the anodes in a typical galvanic corrosion cell, in the process of generating current and, thus, have a limited service life. The galvanic anodes are fabricated from active metals and alloys; three basic materials are used magnesium, zinc, and aluminum of high purity or other special composition.

The impressed current system utilizes low-voltage, high-amperage, direct current from an external power source (Figure 7-2). The positive terminal of the power source must be connected to the anodes, and the

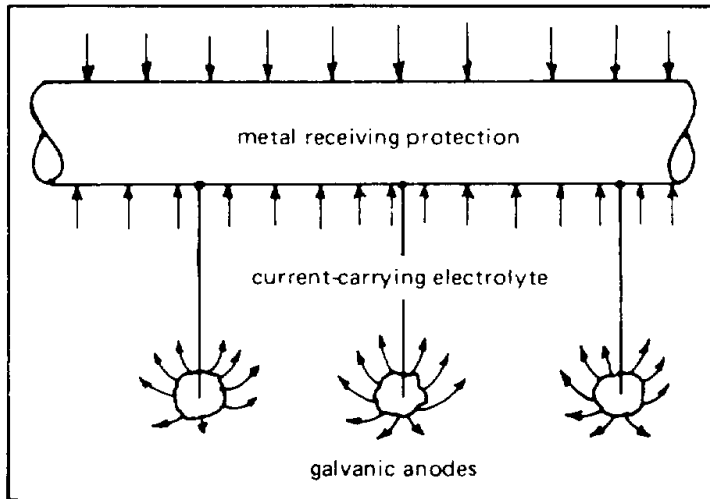
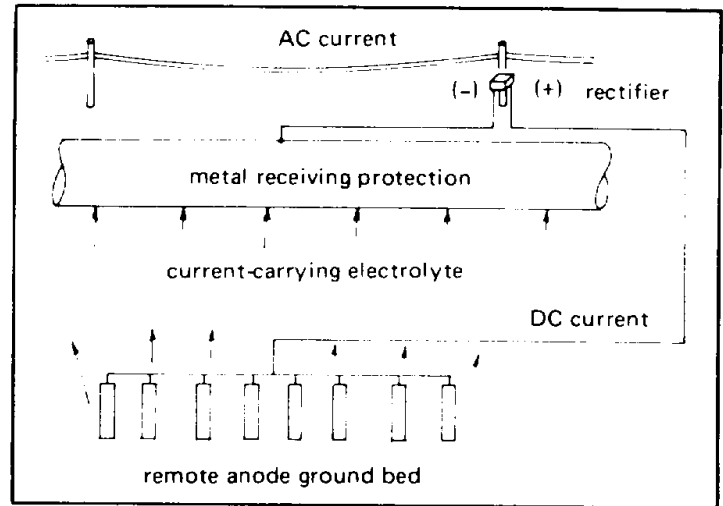

Figure 7-1. Galvanic system of cathodic protection.



alloy,
Figure 7-2. Impressed current system of cathodic protection.

negative terminal to the structure to be protected. The relatively stable anodes used to discharge current have much longer service lives than galvanic anodes. These anodes can theoretically be made from any electrically conductive material. However, unless the material is inert in the environment, it will be consumed. Scrap iron, special lead alloys, platinum, platinum-palladium

alloy, platinumized titanium alloy and platinumized tantalum alloy are some of the materials used for the anodes. Normally, rectifiers are used to supply the DC power to the system using available AC shore power. Sections in References 7-1, 7-13, and 7-14 discuss the selection of and requirements for cathodic protection rectifiers.

SECTION 4. SUBSTITUTE MATERIALS FOR STEEL

7.4.1 ALLOYS. There are many alloys which, if used properly, are more resistant to corrosion by seawater and marine atmospheres. These alloys exhibit three types of corrosion behavior. Some are essentially immune to corrosion, while some corrode but at rates significantly slower than steel. Some of these alloys are essentially corrosion free if properly used, but may corrode at extremely rapid rates if used improperly.

7.4.1.1 Titanium Alloys. The titanium alloys are essentially free from corrosion except for stress-corrosion cracking in some alloys. The chemically pure grades and the heat-treatable alloy 6A1-4V annealed

(100-ksi yield) are known to be immune to all forms of attack in seawater and marine atmospheres at temperatures below 1500F. These alloys are high in cost and difficult to fabricate. They are, however, relatively high in strength and low in weight.

7.4.1.2 Nickel Alloys. Nickel alloys, depending on their composition, can exhibit either totally immune behavior or can be essentially immune when used properly. Inconel alloy 625 and Hastelloy alloy C are essentially immune to corrosion in marine environments.

Monel alloy 400 normally exhibits immune behavior when it receives cathodic protection from a more active material. (See MO-306, [7-1]). If the area ratio is favorable (small area of monel/large area of anodic material), the amount of acceleration of corrosion of the anodic material will be insignificant. However, if it is not cathodically protected, this alloy will corrode due to pitting and crevice attack.

7.4.1.3 Copper Alloys. Many of the copper alloys corrode uniformly at low rates when exposed to marine environments in low velocity water movement. These alloys include copper, cupro-nickel 90-10, cupronickel 70-30, arsenical admiralty brass, and most true bronzes. Most of the true brasses are generally attacked by dezincification and are unsuitable for marine applications.

7.4.1.4 Aluminum Alloys. The aluminum alloys are subject to pitting and crevice corrosion in marine environments. This is particularly true in submerged structures. If pitting can be tolerated (for instance, in an open framework structure) and if crevices can be eliminated (by using welded structures), the aluminum alloys can be successfully used in marine applications where their low weight or other unique properties would be utilized. They should not, in general, be substituted for steel on the sole basis of corrosion resistance. Of the aluminum alloys the 5000 series (5083 and 5086) and the 6000 series (6061) alloys have the best corrosion resistance. Alloys in the 2000 series, 3000 series, and 7000 series are less corrosion resistant.

7.4.1.5 Stainless Steels. It cannot be overemphasized that stainless steels can and do corrode in seawater. The stainless steels can be essentially immune to corrosion in marine environments when they are

properly used. However, they corrode very rapidly in marine environments when improperly used. The predominant mode of corrosion of the "marine grades" of stainless steels the 300 series is crevice corrosion. If crevices are avoided or if they are cathodically protected (possibly by galvanic coupling), these alloys can be essentially corrosion free. However, rapid failure from corrosion in existing crevices will result when the alloys do not receive cathodic protection. Stainless steel grades 304 and 316 are the most widely used "marine grade" stainless steels. Grades 303 and other series, such as the 400 series, should be avoided. Alloy 30-Cb has somewhat greater corrosion resistance than grade 316, but it is susceptible to crevice corrosion.

7.4.2 PLASTICS. There are a number of plastic or elastomeric materials that find uses as components of waterfront structures rather than metals. Fiberglass-reinforced plastic landing floats, brows, and mooring buoys have been prepared by using spray-up or lay-up construction techniques [7-15]. With proper design they can be quite rugged and require very little maintenance. Such construction techniques can also be used for applying a tough protective coating to steel structures, such as buoys.

Urethane, polystyrene, and syntactic foams are available in a variety of densities and forms for imparting buoyancy to floating structures. Urethane has a greater capability than the others, in that it is easily foamed in

place [7-16]. For more information see Chapter 8 of this manual.

7.4.3 RUBBER. A number of hollow and solid rubber products are available for use as fenders on piers, wharves, landing floats, camels, and mooring buoys.

SECTION 5. INSPECTION

7.5.1 GENERAL CONSIDERATIONS. Because of rapid corrosion, continuous inspection is a basic requirement of the maintenance program for steel waterfront structures. An inspection program identifies all deficiencies and degree of hazard and determines proper corrective action.

when evaluating the information obtained from an underwater inspection.

7.5.2 INSPECTION TECHNIQUES

7.5.2.2 Cutting of Metal for Thickness Measurement. When normal caliper-type measurement of metal thickness is not possible, holes can often be cut in the members to determine material thickness. This can be performed only when the presence of a small hole can be tolerated or the hole can be patched.

7.5.2.1 Visual Inspection. It is vital that the actual metal surface be inspected where deterioration is proceeding. Marine fouling, dirt, loose paint, or corrosion products will interfere with an accurate assessment of the extent of deterioration and so must be removed before inspection. Of course, coatings which are supplying protection to the surface and are not defective should not be removed for inspection. Visual inspections can be used to determine the location and relative extent of corrosion on many structures. Measurement of metal thickness by gages, etc., can, in many cases, give accurate and quantitative determinations of the extent of corrosion. Careful visual examination can also be used to determine the cause of the corrosion.

7.5.2.3 Ultrasonic Testing. Ultrasonic testing can be used both to determine metal thickness and to detect internal flaws. Instruments are now available that directly indicate metal thickness. These instruments are well-suited to general determinations of metal thickness and only require access to one side of the member. These instruments can be used in the field with a minimum of operator training. Instruments for location of internal flaws are also available. However, the operation of these instruments and the interpretation of the test results are heavily dependent on the skill and experience of the operator. Both types of these devices could be adapted for underwater use.

When structures are below water and are difficult or impossible to bring above water, a diver can be used to perform the inspection. He must be able to obtain and report information on the condition of the underwater structures (see Appendix A). The limitations of the divers senses underwater must be considered

7.5.2.4 Radiography. Radiography (X-ray) can be used to determine variation in metal thickness and detect certain types of internal flaws (voids and inclusions).

Radiography has the advantage of producing a record (film) that can be viewed and interpreted at a later date. Also, radiography can often be used to penetrate coatings, etc., which interfere with many other inspection techniques.

7.5.2.5 Microscopic Testing. Microscopic inspection of the internal structure of a material is most often performed in a material testing laboratory on samples removed from a structure. While this form of inspection can determine the extent of deterioration, it is most often used to determine the form of attack. Often the form of attack must be determined in order to find the cause of attack and recommend corrective action.

7.5.2.6 Examination of Corrosion Products.

Chemical analysis of corrosion products is, like microscopic testing, most often performed in a laboratory on samples removed from a structure. The composition of the corrosion products is normally useful in the determination of the cause of attack, not the extent of attack.

7.5.2.7 Potential Measurements on Cathodically Protected Structures.

The extent of protection can be determined by measuring the electrical potential of a cathodically protected buried or submerged structure. Techniques for determination of these potentials are outlined in References 1-4 and 7-1. Criteria for evaluation of these potentials are given in References 7-13 and 7-14.

7.5.3 SPECIFIC STRUCTURES

7.5.3.1 Piling. Pipe, H, and sheet piling (including tie rods) should be inspected for extent of corrosion, metal thickness, condition of coating, and level of cathodic protection (where appropriate). It may be necessary to

remove fouling by scraping to expose immersed metal surfaces. Mechanical damage and structural integrity must be determined (Figure 7-3). Soil subsidence behind sheet piling is evidence that holes in the piling exist (Figure 7-4). An outward displacement of a quaywall or steel piling is evidence that broken tie rods exist. Divers and boats are both appropriate methods for inspecting piles.

7.5.3.2 Floating Pontoon Structures. Floating pontoon structures are sometimes used as landing floats, lifts, camels, etc. They should be inspected for seaworthiness, corrosion below water which would lead to sinking, and condition of fendering. Nonskid matting may be of advantage on slippery surfaces.

7.5.3.3 Supporting Components. Structural components above the water and below the deck (e.g., wales, braces, etc.) are best inspected from a boat. The extent of corrosion, metal thickness, mechanical damage, and condition of coating should be noted.

7.5.3.4 Utility Lines. Utility distribution systems (Figure 7-5) should be inspected at least annually and possibly more frequently as necessary, depending on the particular installation and type of service given. The following paragraphs define the utility distribution systems, and Table 7-2 presents a few inspection checkpoints that are adequate for average installations. Further detailed procedures for the inspection of utility distribution systems are given in the appropriate references of each service. The preventive maintenance inspector should report breakdowns immediately to the cognizant supervisor. Records of all inspections of utility distribution systems should be maintained.

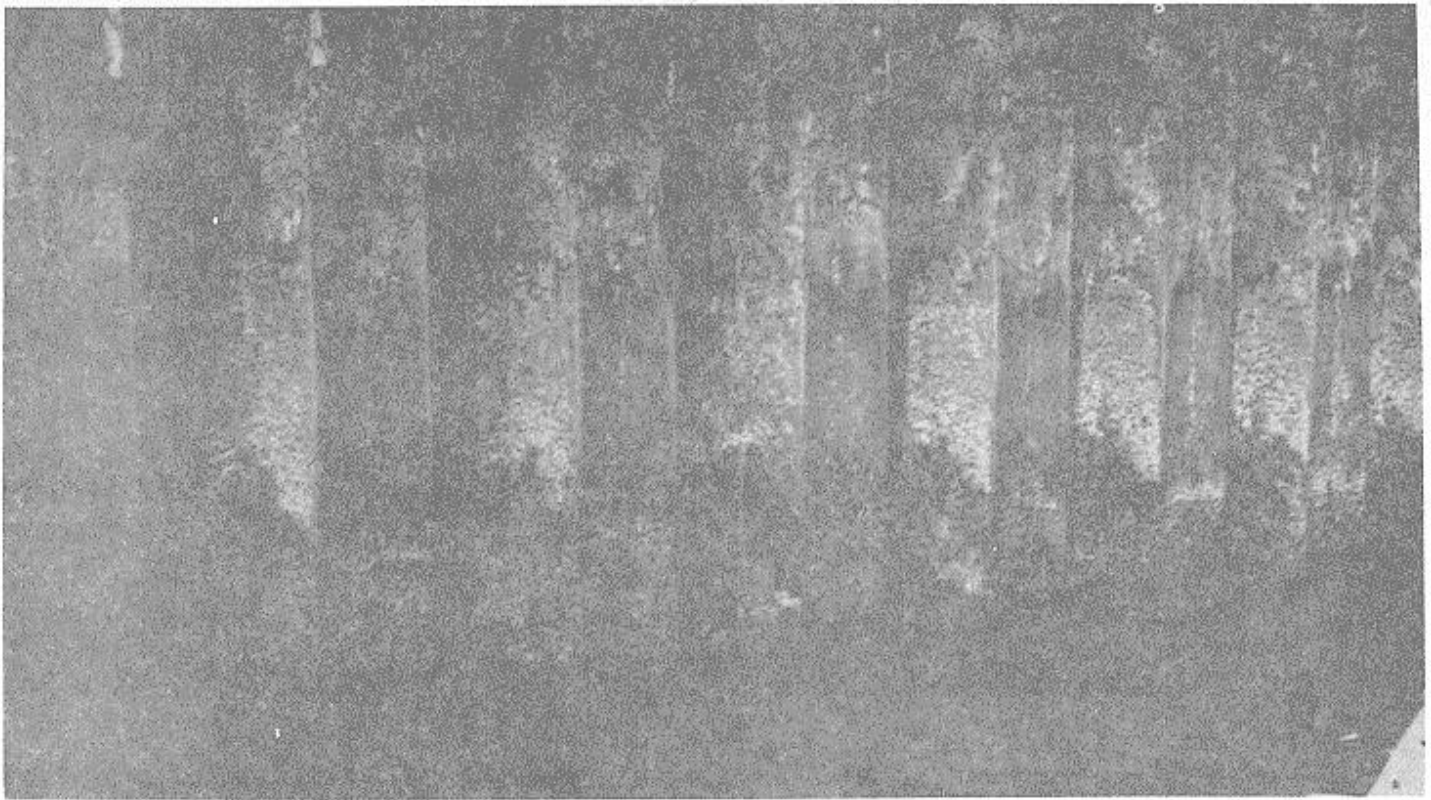

Figure 7-3. Typical example of corrosion damage to sheet piling.

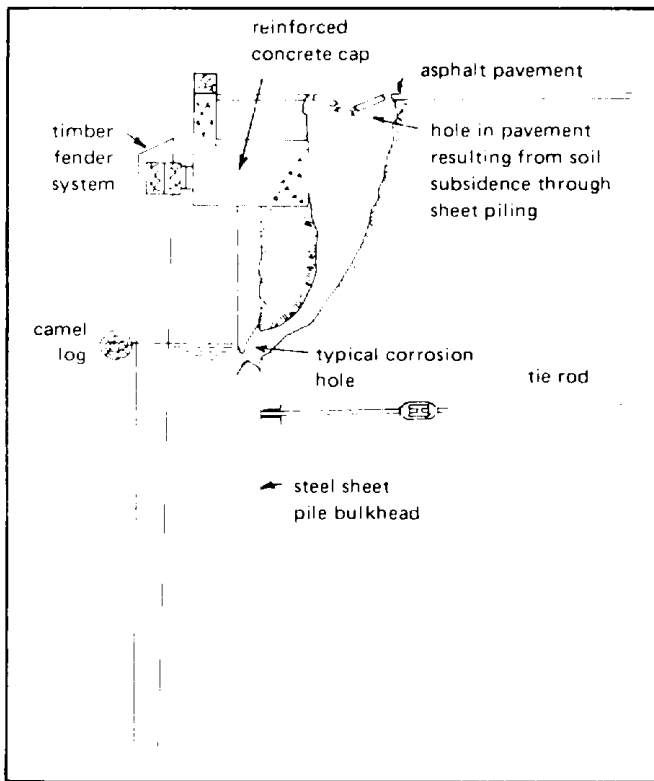

Figure 7-4. Hole in sheet piling causing soil subsidence.

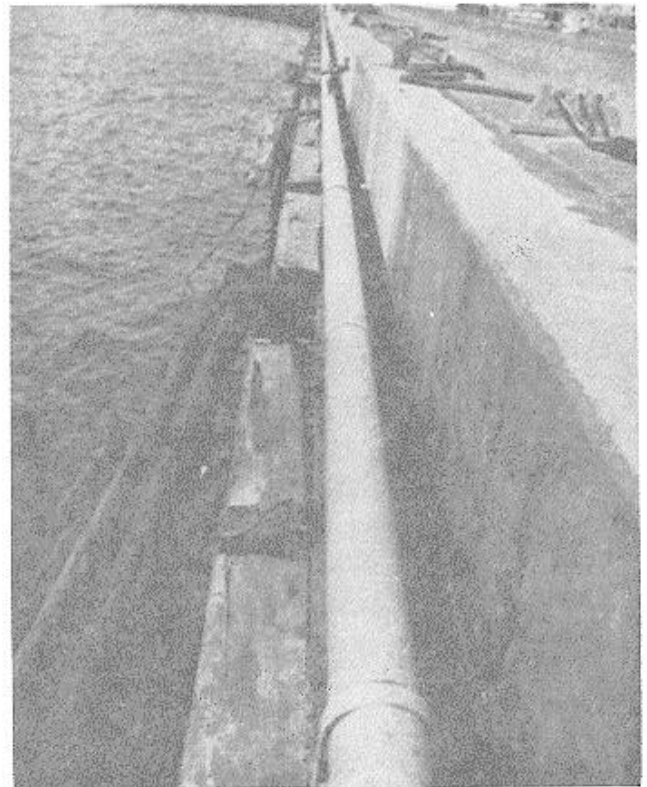

Figure 7-5. Example of utility line properly emplaced.

Table 7-2. Inspection Checkpoints for Utility Distribution Systems

Type of Line	Inspection Checkpoints
Steam distribution and condensate return systems; hot water distribution system	<p>Monthly:</p> <ol style="list-style-type: none"> 1. Pipes for leakage; damage to insulation; abnormal pressures and temperatures; abnormal pressure drops; vibration. 2. Anchors, hangers, and supports for corrosion, breakage, or cracks. pressure and temperature controllers, strainers, and auxiliaries. <p>Yearly:</p> <ol style="list-style-type: none"> 1. Pipes for corrosion, leakage, and loose joints; condition of insulation; damaged protective jackets. 2. Poles, hangers, or other supporting members for settling or shifting of position. 3. Condition of anchor, hangers, guides, and supports. 4. Valves for leakage or corrosion; defects in stems, handwheels, flanges and gaskets. 5. Settings of relief and safety valves. 6. Condition and calibration of pressure-reducing stations. 7. Signs of corrosion on condensate return pipings. 8. Fittings for tightness, threads in good condition.
Water distribution systems [potable (freshwater), salt water or fire protection, and chilled water]	<p>Yearly:</p> <ol style="list-style-type: none"> 1. Pipes for leakage, corrosion, loose connections; defective caulked joints on bell-and-spigot pipes; loose bolts on flanged pipe; damaged or missing hanger and supports; mechanical damage; rust, corrosion, scaling, peeling, alligating, or damage to protective coatings; excessive supply pressure, water hammer, or vibratory noise in line. 2. Valves for leakage, rust, corrosion; visible defects in stem, handwheel, body, packing gland, flanges, and gaskets; difficulty of operation, condition, or damage to protective coatings. 3. Shore-to-ship pier connection fittings shall be removed to insure threads are safe. 4. Meters for leakage, corrosion, broken glasses; evidence of faulty operation.

continued

Table 7-2. Continued.

Type of Line	Inspection Checkpoints
Sewage collection systems	Yearly: 1. Pipes for leakage, rust, corrosion, and deteriorated coating; clogging, sluggish flow. 2. Check for loose, missing, or broken supports and anchors, and other damage.
Gas distribution systems	Yearly: 1. Pipes for leakage, loose connections, rust, corrosion, and other damage. 2. Condition of anchors, hangers, and supports. 3. Location of piping (should never be installed under a building). 4. Guardrails protecting aboveground piping that is near a street or is vulnerable to damage by vehicular traffic; piping appropriately painted. 5. Leaks accurately marked with tags to show classification of leak. 6. Valves for leakage, loose connections, rust, corrosion; defective operation. 7. Connections for leaks. 8. Meters for loose connections, leakage, corrosion, rust, broken glass, defective gaskets, dirt, or illegibility.
Compressed air distribution systems	Monthly: 1. Leaks (very important); moisture and dirt in traps, strainers, and dehumidifiers. 2. Abnormal pressures. 3. Vibration. 4. Corrosion. Yearly: 1. Pipes for leakage, corrosion, loose joints, damaged, or missing supports. 2. Settling or shifting of poles, hangers, or other supporting members. 3. Valves for leakage and corrosion; defects in stems, packing glands, handwheels, seats, bodies, flanges, and gaskets. 4. Condition of flanged fittings, expansion joints, hangers, guides, supports, and anchors.

continued

Table 7-2. Continued.

Type of Line	Inspection Checkpoints
	<ol style="list-style-type: none"> 5. Condition of traps, strainers, dehumidifiers, and moisture separators. 6. Condition and calibration of instruments.
<p>Electric power transmission and distribution systems</p>	<p>Yearly:</p> <ol style="list-style-type: none"> 1. Conduits and supports for corrosion; missing or unsecured covers and fittings; plugged drain openings; accumulations of dirt and debris in ducts and wireways; missing fasteners; overcrowding of conductors in conduits, ducts, wireways, and racks; unidentified wires. 2. Insulations for abrasion; broken insulation; defective insulation at splices; inadequate or loose tape, overheated or burned insulation; rodent- or insect-damaged insulation. 3. Conductors exposed to pedestrian or vehicular traffic. 4. Exposure to water, grease, and oil. 5. Receptacle outlets, panels, and miscellaneous fittings protected against foul weather and entrance of dirt and moisture; dirty or corroded contacts; hotspots, burning, and arcing; loose fittings; defective grounding; missing, illegible, incorrect, or inadequate indexing, instructions, or phase and polarity markings; missing or loose covers of outlet boxes, receptacles, and terminal boxes; corrosion of exposed metal surfaces; overloaded circuits; and visibility of fire alarm boxes. 6. Pier lighting and flood lights for dirt, rust, corrosion, loose connections, charred insulation, arcing, and illumination level.
<p>Petroleum fuel distribution systems</p>	<p>Yearly:</p> <ol style="list-style-type: none"> 1. Piping for leakage and loose connections; damaged or missing hangers and supports; misalignment causing undue stresses at pipe joints; defective gland nuts and bolts at expansion joints and clamp-type couplings; rust, corrosion, cracking, scaling, peeling or damaged paint or protective covering; failure to maintain electrical continuity for grounding connections; inaccurate, illegible, and improper paint color for signs and markings. 2. Valves for leakage and corrosion; visible defects in stem, operating handwheel or lever, packing gland, flanges, and

continued

Table 7-2. Continued.

Type of Line	Inspection Checkpoints
	<p>gaskets; wear, mechanical damage, or difficult operation; damage to protective coating; identify cast iron valves for future replacement.</p> <ol style="list-style-type: none"> 3. Meters, pressure gages, and other accessories for leakage; cracked dial cover glasses; defective gaskets; mechanical damage or inaccuracy of indicating and recording mechanisms; rust, corrosion, broken weld; loose, missing, or damaged parts; unsafe conditions; deteriorated parts of ladders or catwalks. 4. Assure fuel connections are inboard of pier edge; concrete curbs or metal drip pans are provided around fuel risers and connections; plugs are provided for openings in curbs or pier decks.
Telephone wire systems and fire alarm systems	<p>Yearly:</p> <ol style="list-style-type: none"> 1. Defective faceplate; dirt. 2. Loose wire connections, crosses, or shorts. 3. Corroded, deteriorated, or damaged wires. 4. Adequate clearance from trees, electric light and power wires, or buildings. 5. Condition of protector. 6. Kinks; cut in cable; creeping cable; loose or misplaced cable guards and supports. 7. Defective insulation; improperly terminated wires. 8. Debris hanging on wires. 9. Nonuniform, excessive, or insufficient sagging. 10. Proper grounding.
Shore-to-ship utility lines	<p>Prior to each use and after connection:</p> <ol style="list-style-type: none"> 1. All portable lines for Cold Iron (Hotel Service) examined for mechanical damage and abrasion. 2. Electrical distribution lines checked for equal length prior to connection and for overheating after service established. 3. All hoses checked for leakage and excessive stress after placement.

7.5.3.4.1 Steam Distribution and Condensate Return Systems. Steam distribution and condensate return systems are defined as the piping between the point of supply to the point of steam use. The basic components of the systems normally located at waterfront facilities include: steam and condensate piping, expansion joints and loops, pipe anchors, valves, insulation and covering, conduit, and structural supports. Jackets in seawater should be checked for watertightness. See Table 7-2 for inspection checkpoints.

7.5.3.4.2 Hotwater Distribution Systems. Hotwater distribution systems are defined as piping in which water is circulated between the source and the point of hotwater use. The basic components of the hotwater systems normally found at waterfront facilities are: pipes, valves, expansion joints and anchors, and drains and vents. See Table 7-2 for inspection checkpoints.

7.5.3.4.3 Water Distribution Systems. Water distribution systems are defined as all water conduits and supply mains, with necessary appurtenances, through which water is conducted between the source and the point of utilization. Nonpotable water systems for fire protection and sanitary purposes are included. The basic components of systems normally found at waterfront facilities are: conduits, supply mains and service lines, valves, manholes, hydrants, meter and equipment for measurements and control, and all appurtenant equipment, such as automatic controls and cathodic protection devices. See Table 7-2 for inspection checkpoints.

7.5.3.4.4 Sewage Collection Systems. Sewage collection systems are defined as all conduits, sewers, and appurtenances through which domestic sewage or industrial wastes are collected and transported between

the point of origin and the point of discharge. Pumping stations are not included. The basic components of sewage collection systems normally found at waterfront facilities are: force mains, main sewers and laterals, and small individual disposal devices, such as septic tanks.

7.5.3.4.5 Gas Distribution Systems. Gas distribution systems are defined as all government-owned gas piping between the source and point of gas use. The basic components of gas distribution systems are: piping, valves, expansion joints, anchors, drains, meters, pressure regulators, and cathodic protection. Gas distribution systems are seldom found under piers or wharves; however, if one is already installed, the checkpoints given in Table 7-2 should be followed.

7.5.3.4.6 Compressed Air Distribution Systems. Compressed air distribution systems are defined as the compressed air piping between the compressor room and the point of use. The basic components of compressed air distribution systems are piping, valves, expansion joints, anchors, drains, and pressure regulators. See Table 7-2 for monthly and yearly inspection checkpoints.

7.5.3.4.7 Electric Power Transmission and Distribution Systems. Electric power transmission and distribution systems are defined as (1) overhead and underground transmission and distribution lines from generating stations, or delivery point to all main service entrance switches in a building; (2) exterior lighting systems, including street lighting, flood lighting, perimeter lighting, and security lighting; and (3) fire alarms systems.

The inspection procedure should comply with all current safety precautions, remembering that shock hazards are intensified in the waterfront environment. See Table 7-2 for inspection checkpoints.

7.5.3.4.8 Petroleum Fuel Distribution Systems. Petroleum fuel distribution systems are defined as piping systems in which petroleum fuel is received from a transporting vessel or discharged from storage. The basic components of the systems include piping, valves, control equipment, ground connections, signs, and markings. Motor vehicle fill stands, drum-filling plants, or storage tanks are not included.

Early detection of corrosion attack upon the various fuel facility components constitutes one of the most important phases of inspection (see Reference 7-17). A record of all inspections of fuel systems should be maintained. See Table 7-2 for inspection checkpoints.

7.5.3.4.9 Telephone Wire Systems. Telephone wire systems are defined as wire communication systems which convey intelligibility from speaker to the listener. The basic components of the systems normally located at waterfront facilities are receiver, transmission lines, connecting boxes, and cable terminals.

The inspection procedure should comply with all current safety precautions. See Table 7-2 for inspection

checkpoints.

7.5.3.5 Mooring Fittings. Bollards, bitts, cleats, chocks, rings, and other steel mooring fittings must be inspected for extent of deterioration to determine if the fittings, holddown bolts, or foundations need repair or replacement (Figure 7-6). Necessary requirements for painting or refilling of boltholes should be determined.

7.5.3.6 Drydocks (Graving Docks, Marine Railways, and Lifts). Drydocking facilities must be maintained to the extent necessary to protect and preserve the structure and all operating equipment to assure full, safe, and efficient use of the facilities at all times. See Appendix B for more information on inspection of graving docks.

7.5.3.7 Floating Structures. Steel pontoons, landing floats, barges, floating cranes, floating caissons (graving dock entrance closures), and miscellaneous floating structures must be inspected regularly for structural damage, water-tightness, corrosion, condition of coating, and where appropriate, extent of marine fouling. If marine fouling organisms are significantly reducing the buoyancy or increasing the drag of moving equipment, they must be removed by in-place cleaning or by cleaning after drydocking.

SECTION 6. MAINTENANCE OF STEEL STRUCTURES

7.6.1 STRUCTURAL CONSIDERATIONS. Structural engineers should be consulted to ensure that the repair method will restore the steel structures to the desired strength and that the most effective method of repair

has been chosen. Load-carrying members are usually replaced when 30% or more of the steel has been lost by

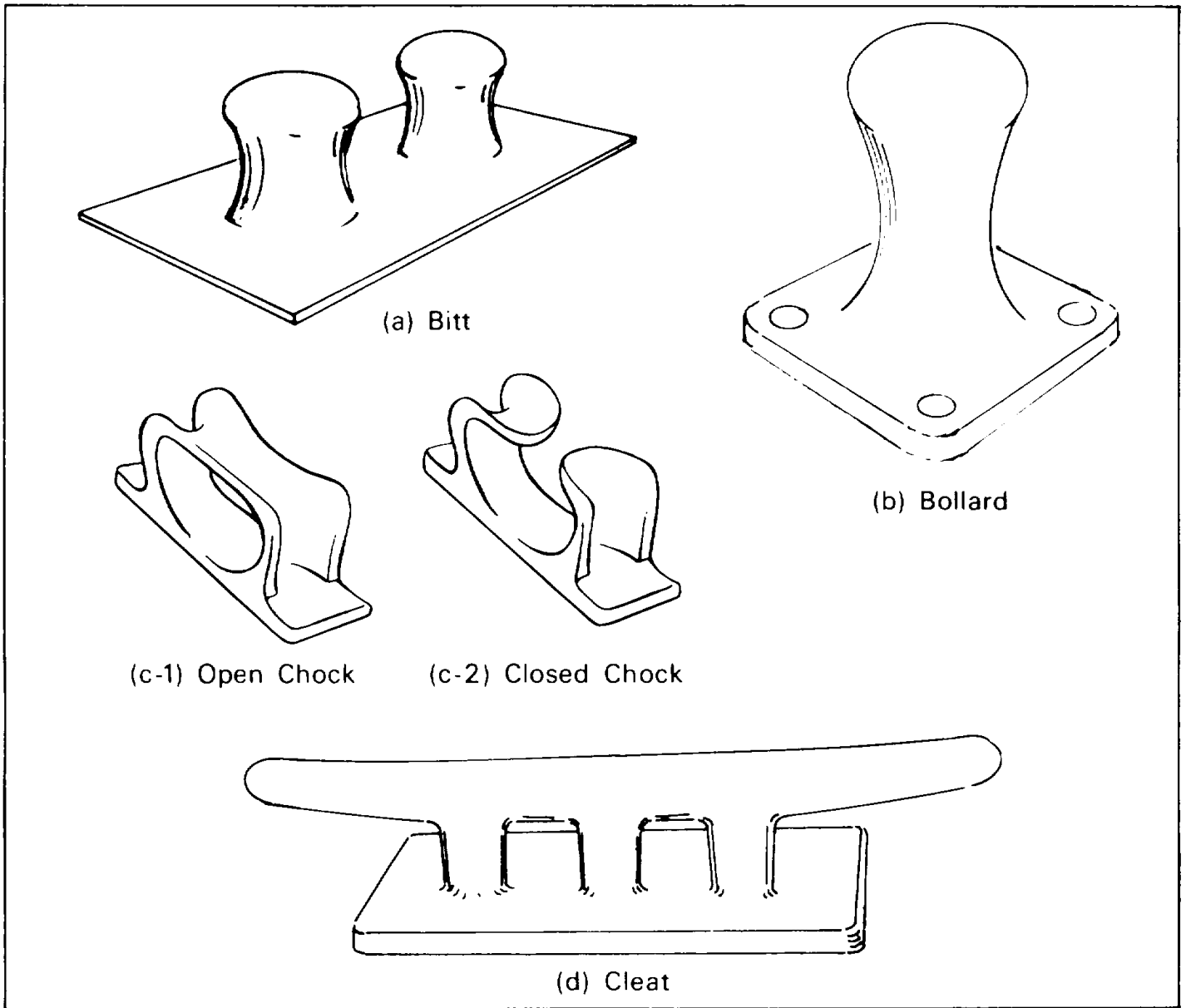

Figure 7-6. Examples of mooring fittings.

corrosion or when they are deformed. If adjacent members show signs of serious deterioration, it may be more economical to replace whole frames or bents. A stressed member should not be removed before the stress has been relieved by transfer of load to adjoining members or by new temporary members and adequate bracing. In the replacing of piles, the load should be shifted temporarily to other piles by struts or beams using jacks. The replacement of wales on quaywalls may require excavation of fill to relieve lateral loads. In

some cases, it may be more economical or practical to strengthen existing members than to replace them. This is especially true where corrosion is serious in only a limited area.

7.6.2 PILING. Steel piling requiring coating should be treated as described in 7.2. Those requiring cathodic protection should be treated as described in 7.3. The

cathodic protection systems themselves must be inspected for depleted anodes, corroded or loose connections, electrical continuity, etc., and maintained on a yearly basis to assure continuous protection of the steel.

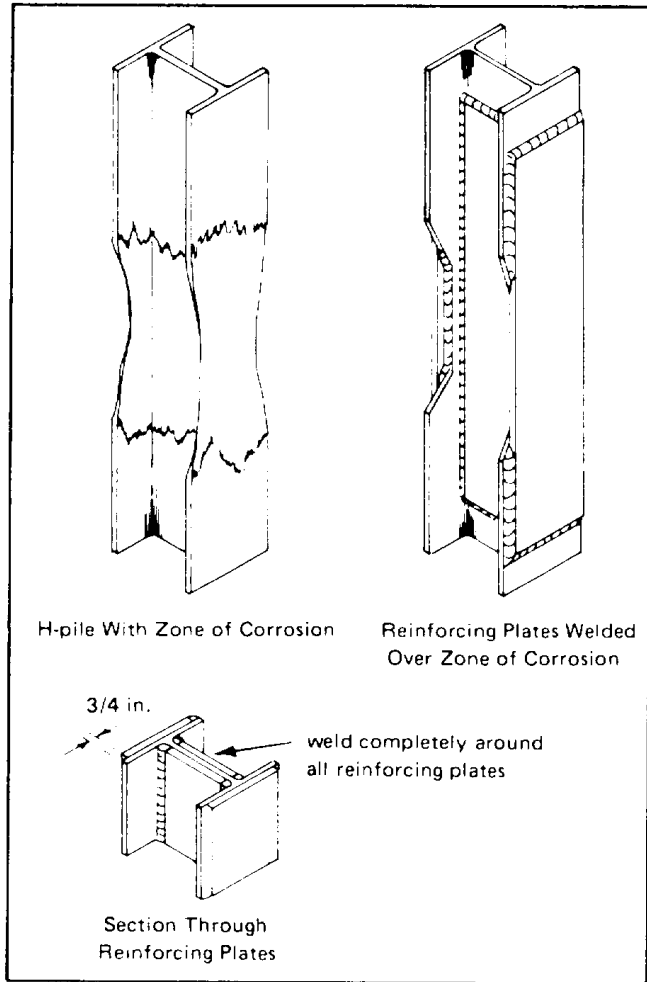

Figure 7-7. Repair of corroded steel pile.

7.6.2.1 H-Piling. Reinforcement of H-piling by welding steel plates onto flanges and web may be appropriate in localized areas of corrosion, such as the tidal zone. The reinforcing plates should be of sufficient thickness to restore the original strength to the piling and of sufficient area to encompass and extend beyond the extremities of the corroded area (Figure 7-7). The old steel must be cleaned and cut back to a point where the metal thickness will ensure a strong weld. All cut edges should be feathered, and the weld should be made completely around the plate to eliminate crevices.

Another method of reinforcement utilizes encapsulation in reinforced concrete. In this method, reinforcing rods are welded along the main axis of the repaired member, across the damaged area. Ties are welded or tied at all intersections with reinforcing steel, a form is placed around the piling, and concrete is placed inside as described in Chapter 3. When replacement is necessary, the new piling must be accurately fabricated to match the old, making sure that bolt and rivet holes are properly located. When replacing bearing piling, the new pile is generally driven alongside the old one at a slight angle. It is then cut off at the proper elevation, capped (usually by welding on a steel plate), and pulled into position with a block and tackle. If the old pile is removed before the new one is driven, the load must be temporarily transferred until the new pile can assume it.

7.6.2.2 Sheet Piling. Sheet piling usually serve as a bulkhead to retain fill. Thus, extreme care must be taken during replacement of one or more piles to prevent failure and passage of fill through the opened spaces into the water. More frequently, small holes are patched by welding steel plates over them, and badly deteriorated piling are generally replaced or protected by having new piles driven in front of them. In the latter case new wales, tie rods, and deadmen should be

installed, and the space between the old and new piles should be filled with well-tamped earth, sand, gravel, or concrete.

An alternate method of repairing badly deteriorated piling is to install a concrete facing. The old steel must be cleaned of rust, marine fouling, and other contaminants before a concrete cover of at least 6-inch thickness is installed. A bolted wooden form is generally used for this purpose. When the back of the bulkhead is accessible, the entire steel bulkhead can be encased in concrete with a minimum thickness of 3 inches on each side (Figure 7-8). Whenever backfill is

replaced, it should be added in layers (preferably granular material) and be well compacted. To replace deteriorated tie rods, a trench is dug from the sheet piling to the deadman, and the new rods with new turnbuckles are installed one at a time (Figure 7-9). They should be covered with a bituminous coating, a fabric tape, and a final bituminous coating. The deadman should be inspected, and necessary repairs made before the trench is backfilled.

7.6.2.3 Pipe Piling. Pipe piling repair is generally similar to that of H-piling repair.

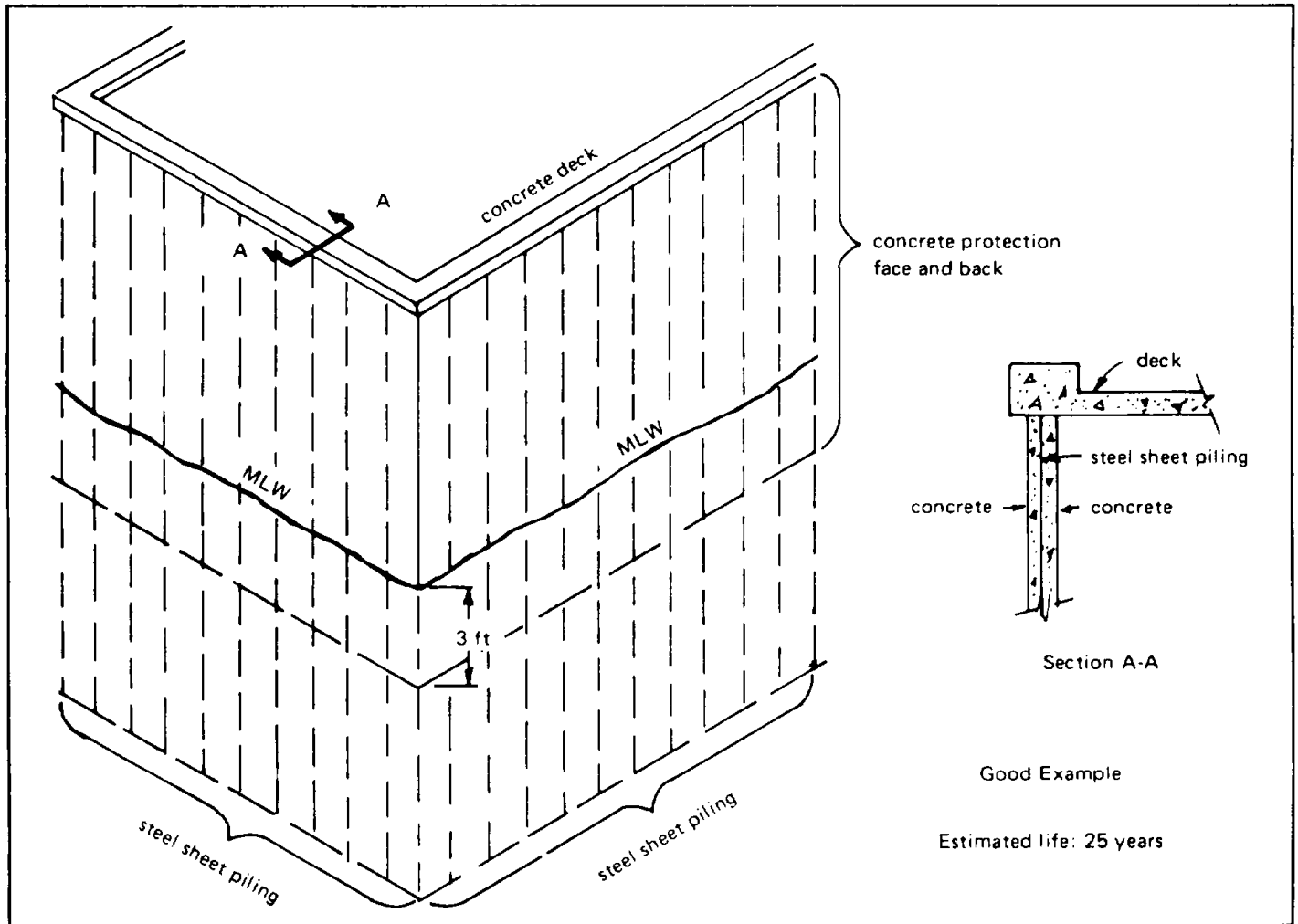

Figure 7-8. Concrete-protected steel sheet piling.

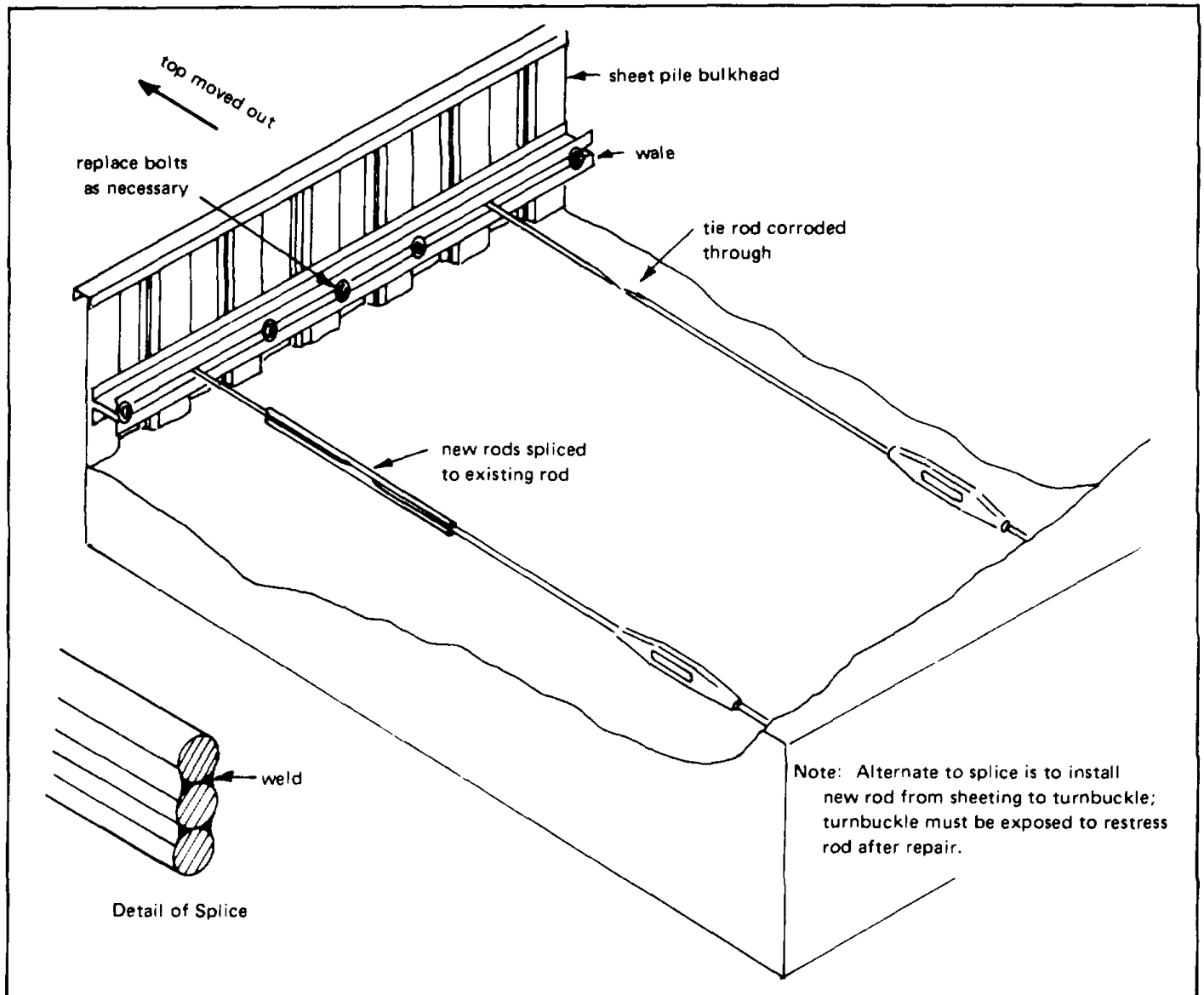

Figure 7-9. Repairing tie rods.

Because of their cylindrical shape they are more easily protected by wraps than are other pilings.

7.6.3 SUPPORTING COMPONENTS. Steel supporting components (wales, braces, etc.) should be repaired or replaced, as necessary. As far as possible, they should be located above the high water line where corrosion is less severe.

7.6.4 UTILITY LINES. The basic objective is to

maintain the distribution systems for the utilities as economically as feasible and still be consistent with operating requirements, sound engineering practice, and proper protection to life, health, and property. All necessary repairs should be made as required by the periodic inspection indicated in Table 7-2. These repairs may require replacing items, tightening loose connections, tightening or repacking valve gland and conduit seal

glands, or welding defective parts or sections. Paints and coatings should be replaced as indicated in 7.2.2 and 7.2.3. References 7-18 and 7-19 give information for protecting fuel lines under piers. The cathodic protection systems should be maintained in accordance with manufacturer's instructions. In gas distribution systems, leaking pipes are repaired by shutting off gas, tightening connections, and rechecking leaks with soapsuds. When working on electrical power transmission and distribution systems, an assistant must always be available to render assistance or first aid. Extensive replacements of defective systems shall be made in accordance with current criteria for new construction.

7.6.5 MOORING FITTINGS. Maintenance of mooring fittings (bits, bollards, cleats, chocks, etc.) includes tightening or replacing bolts; replacement of cracked, broken or badly corroded fittings; and reinforcement or replacement of foundations. Boltheads exposed to the atmosphere should be protected from corrosion by potting the bolt holes with poured lead or with an epoxy

putty. New fittings should be of cast steel and be at least the same size and capacity as those they replace. They should be painted with coal tar (see 7.2.3).

7.6.6 DRYDOCKS. See Appendix. B for more information on graving docks.

7.6.7 FLOATING STRUCTURES. Repair of holes in the sides of floating structures, such as floatings, lifts, and camels, should be made by welding on steel plates. The plates should be rounded and the welding be as smooth as possible to avoid conditions which accelerate corrosion. Temporary patching can be made by bolting plates over the holes or with epoxy putty if welding of plates would require drydocking. Cathodic protection will protect the underwater steel from corrosion, and protective coatings should be used above water. Because of their resistance to impact and abrasion damage and to corrosion, zinc inorganic coatings (see 7.2.3) are recommended for steel work decks on barges and cranes.

CHAPTER 8 - PLASTIC AND ELASTOMERIC STRUCTURES

SECTION 1. TYPES OF MATERIALS

Several plastic and elastomeric materials are finding practical use as substitutes for wood, concrete, or steel in waterfront structures or as components in these structures. Mention was made of them in the chapters on wood, concrete, and steel, but they are described in this chapter in more detail.

8.1.1 FIBERGLASS-REINFORCED PLASTICS. The reinforcement of plastics (usually polyester or epoxy) with glass fibers yields a product with improved physical properties [8-1] while retaining its light weight. The plastics are generally quite resistant to deterioration in a marine environment as long as no uncoated glass fibers are allowed to come into contact with water. Materials of such construction have been used in buoys (Figure 8-1), floats, and brows.

8.1.2 FOAMS. Foamed plastics, which are available with a variety of chemical compositions and physical properties (e.g., density, strength, water permeability, etc), are used to impart buoyancy to waterfront structures. They can be formulated to be fire-resistant, and they can be coated for additional resistance to water penetration and to deterioration by weathering. Urethane foams are the most useful to public works personnel because they can be foamed-in-place relatively easily [8-2]. Most tend to yellow and slowly degrade, however, when exposed to direct sunlight;

thus, they are used to fill enclosed, hollow cavities (Figure 8-2). Polystyrene foam (Styrofoam®) is relatively inexpensive to purchase in quantity and can be cut to desired shapes. This material, covered by an inverted box deck, is used extensively for small boat moorings in marinas. Syntactic foams are produced by bonding hollow glass or plastic balloons together with an epoxy resin to produce a strong foam that is resistant to water penetration. This type of foam is used for buoyancy in deep-submergence operations.

8.1.3 RUBBERS. A number of natural and synthetic rubbers are molded into a variety of products, such as fenders, that vary in size, shape, and physical properties. These products are easily secured in place with cables or a line of bolted plates in hollow structures or with an adhesive. They find use on piers, wharves, landing floats, camels, mooring buoys, and pilings (Figure 8-3).

8.1.4 PLASTIC WRAPS. Wraps of flexible PVC have been used to produce an oxygen deficient environment around wood piling to prevent the growth of wood boring organisms (Figure 8-4), and around steel piling to control corrosion. References 8-3 and 8-4 describe how to install this type of system on wooden piling, and Reference 7-9 describes its use on steel piling.

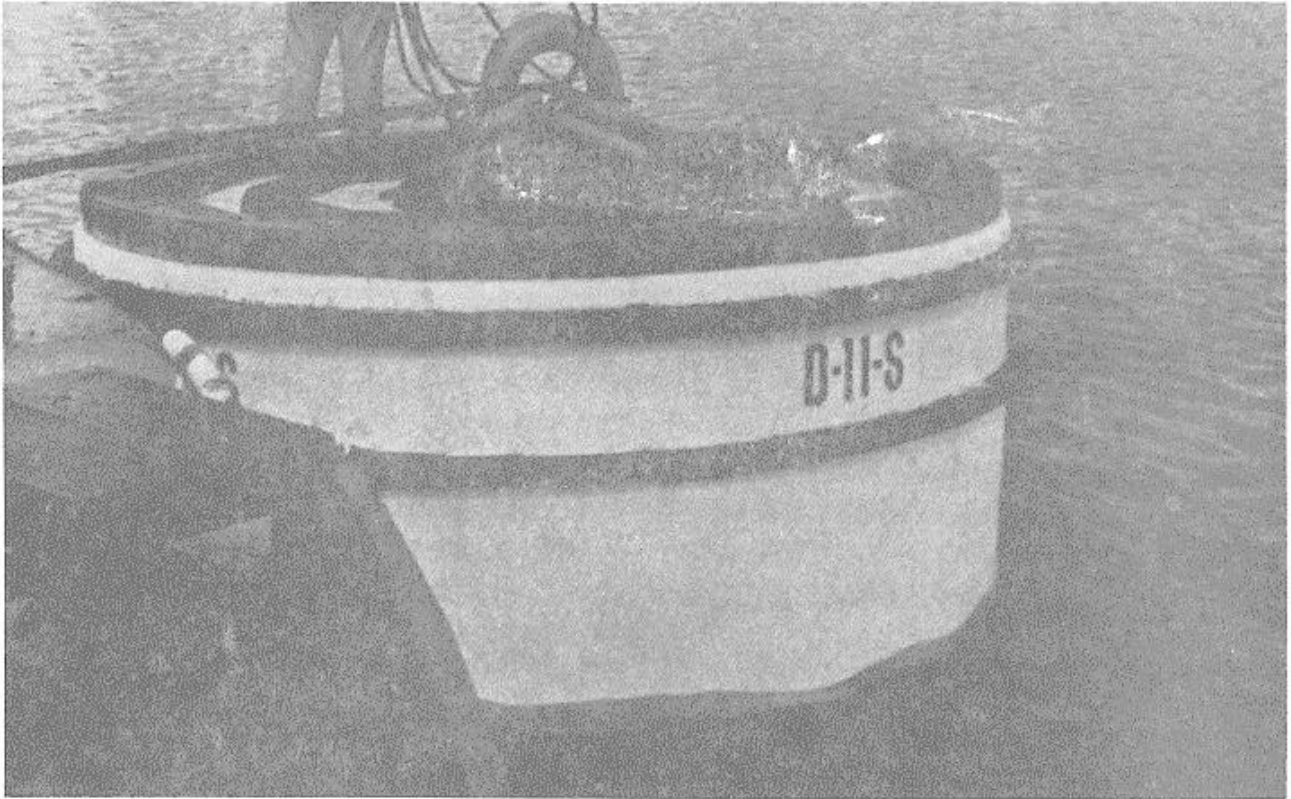

Figure 8-1. Fiberglass-reinforced plastic mooring buoy.

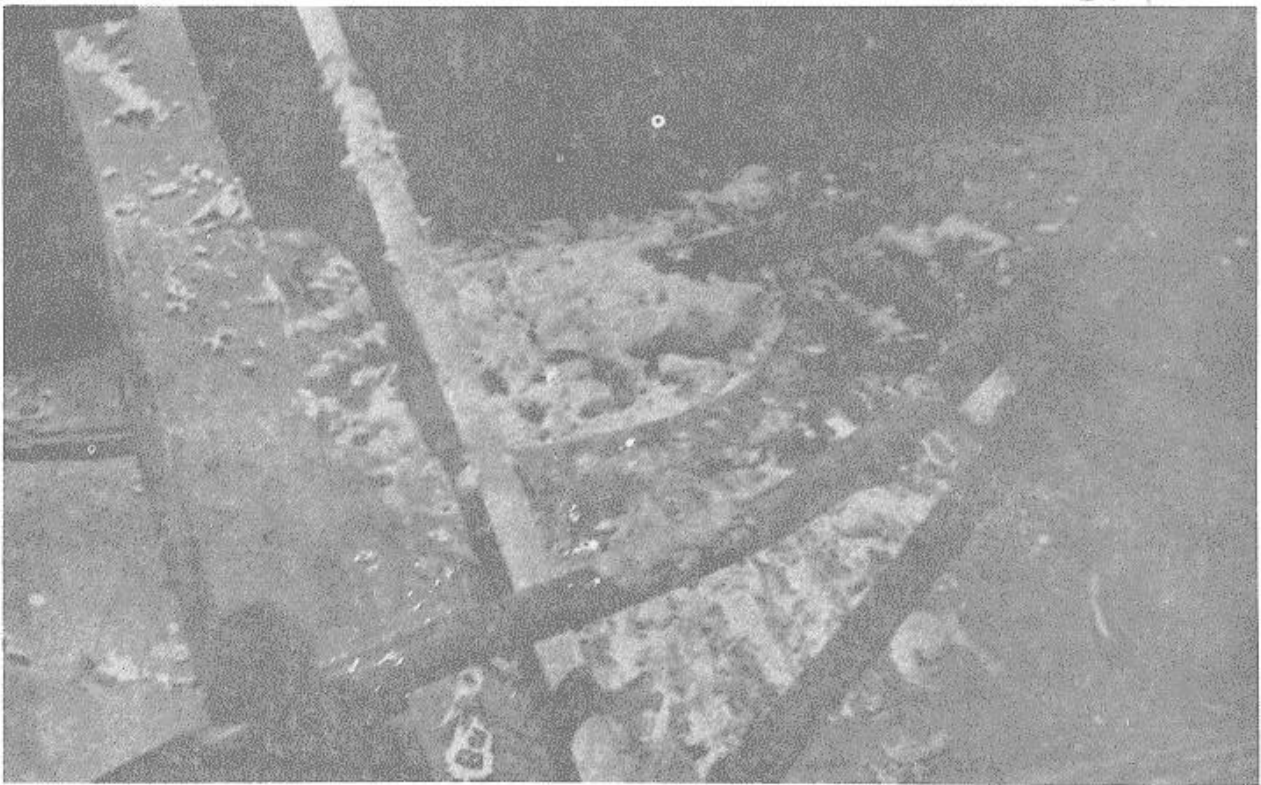

Figure 8-2. Pontoon filled with urethane foam to impart buoyancy.

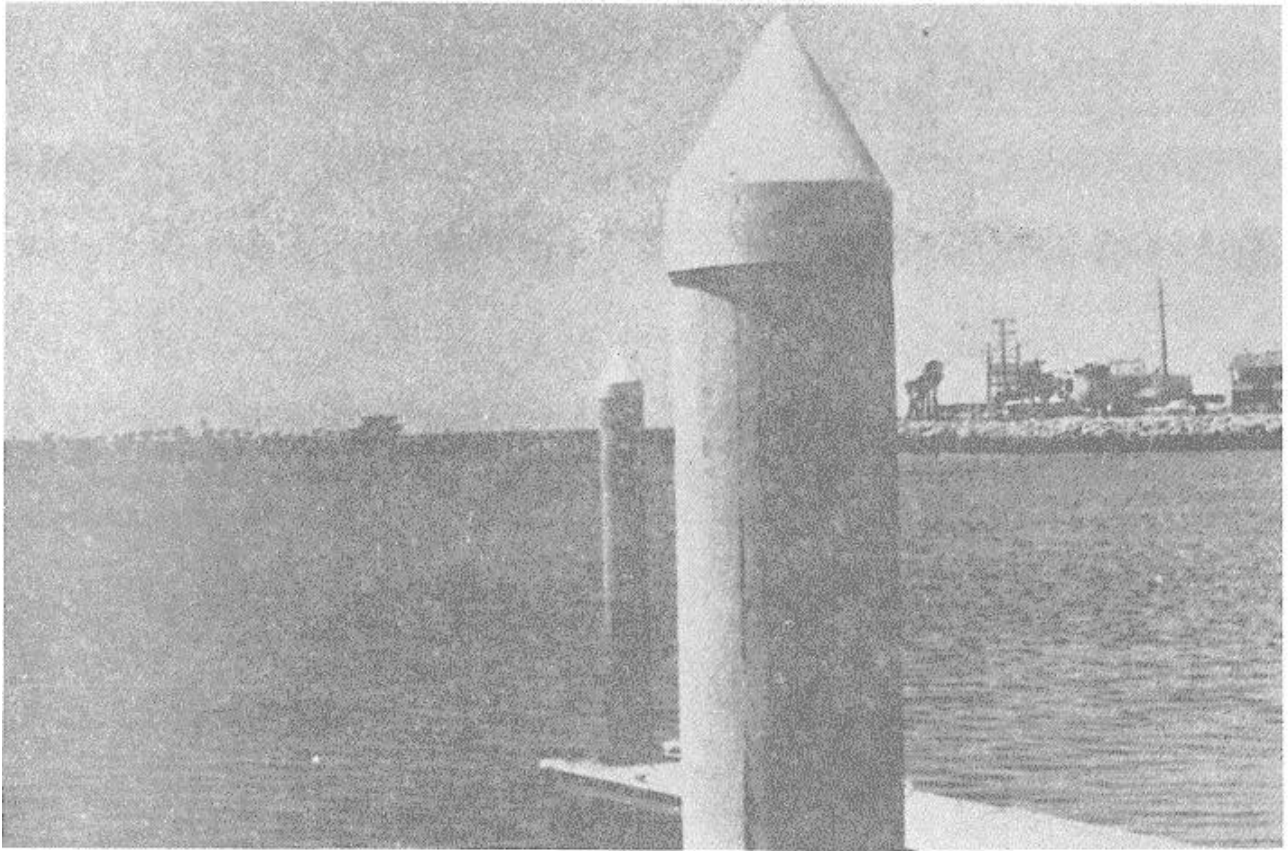

Figure 8-3. Synthetic rubber molded into pile cap. Shape keeps birds from landing and snow from collecting.

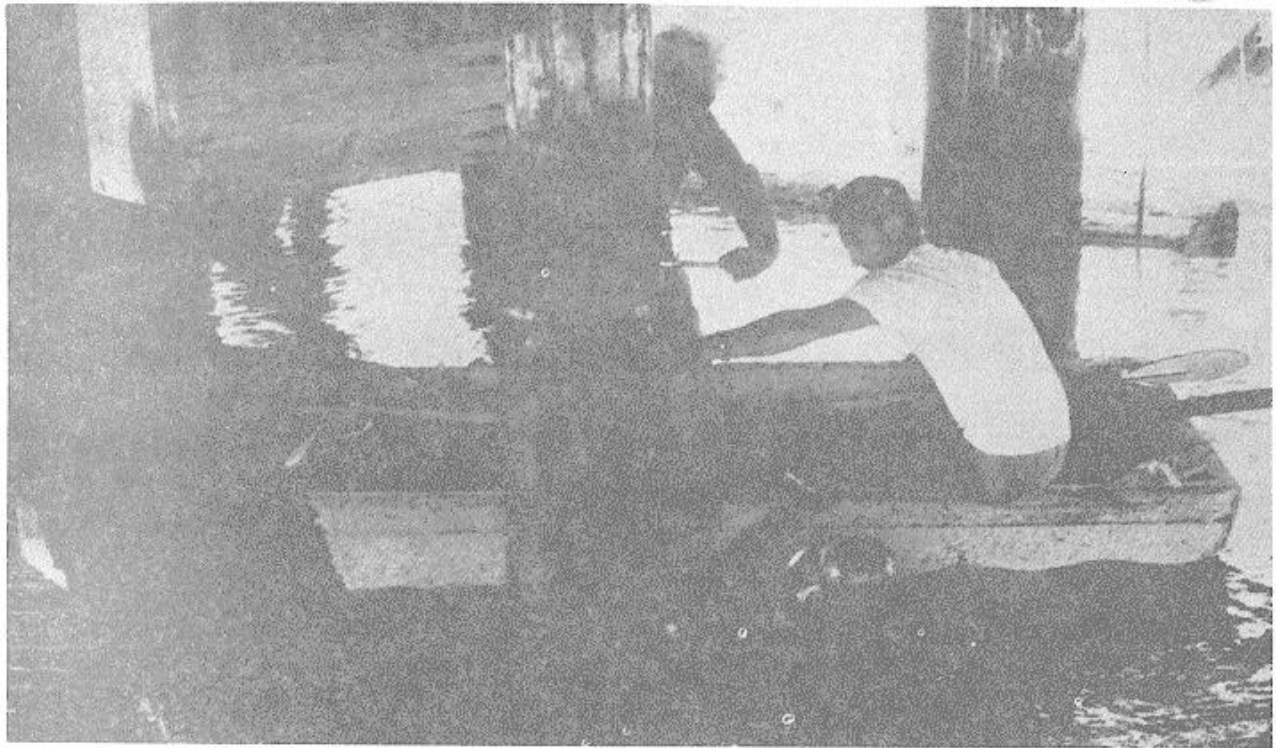

Figure 8-4. PVC barrier being installed around marine-borer-damaged pile.

8.1.5 ADHESIVES AND PUTTIES. Several chemically curing epoxy formulations have been developed that will bond to damp and underwater surfaces. They can be used to bond structures or their components; to pot connections, joints, or other metal configurations

susceptible to corrosion; or to patch holes above or underwater. Reference 8-5 describes one such formulation that was developed by the Civil Engineering Laboratory.

SECTION 2. CONSTRUCTION TECHNIQUES

8.2.1 LAY-UP CONSTRUCTION. In lay-up construction, alternate layers of fiberglass cloth (woven roving) or alternate layers of fiberglass cloth and mat impregnated with catalyzed resin are placed over each other on a mold or other surface to build a laminate of desired strength. The first coat (gel coat) and last coat of resin (usually polyester or epoxy) completely encapsulate the fiberglass.

manner. The process is relatively expensive but produces a very strong and corrosion-free structure.

8.2.4 FOAMING IN-PLACE. Urethane foams can be poured in-place using pails of catalyzed resin or sophisticated metering and dispensing equipment. The rate of rise, density, flammability, and resistance to water penetration can be varied by using different compositions.

8.2.2 SPRAY-UP CONSTRUCTION. In spray-up construction a special spray gun is used that chops glass fibers and extrudes them into a spray of catalyzed resin (usually polyester or epoxy). The irregular film that is formed on the mold or surface is then leveled with a disc roller. This technique can be repeated to build up any desired thickness of fiberglass-reinforced plastic.

8.2.5 PIER WRAPPING. The system described in Chapter 2 for wrapping wooden piling with sheets of PVC can be used for wrapping steel piling [7-10] .

8.2.3 FILAMENT WINDING. Filament winding is a highly specialized technique usually accomplished at a factory. A structure, such as a buoy or pipe, is fabricated by winding a continuous glass filament wetted with resin (either polyester or epoxy) around a mandrel at the desired winding angle. Any desired thickness of fiberglass-reinforced plastic can be produced in this

8.2.6 PATCHING IN-PLACE. Holes, cuts, or dents in metal structures can be patched with epoxy adhesives or putties. Formulations are available for dry and wet surfaces, low and high temperatures, and fast and slow curing. The steel must be cleaned by abrasive blasting or wire brushing before the catalyzed epoxy is placed on it. Leaks in floating structures can be repaired only after the flow of water has been terminated.

REFERENCES

- 1-1. Naval Facilities Engineering Command. NAVFAC MO-311: Marine biology operational handbook. Washington, D. C., May 1965.
- 1-2. Naval Facilities Engineering Command. Design manual NAVFAC DM-25: Waterfront operational facilities. Washington, D. C., Oct 1971.
- 1-3. U. S. Department of the Army. Technical Bulletin TB ENG-250: Repair and utilities: Wood preservation. Washington, D.C., Oct 1963.
- 1-4. U. S. Department of the Army. Regulation AR 420-10: Facilities engineering general provisions. Washington, D. C., Oct 1973.
- 1-5. Naval Facilities Engineering Command. NAVFAC MO-322: Inspection guides; structural, mechanical, electrical, vol 2, Washington, D.C., Apr 1971.
- 1-6. U. S. Department of the Air Force. Regulation AFR 85-1: Resources and work force management. Washington, D.C., Apr 1974.
- 1-7. U. S. Department of the Air Force. Manual AFM 86-1: Programming civil engineer resources. Washington, D.C., Sept 1963.
- 1-8. Naval Facilities Engineering Command. Design manual NAVFAC DM-26: Harbor and coastal facilities. Washington, D.C., July 1968.
- 1-9. Naval Facilities Engineering Command. Design manual NAVFAC DM-29: Drydocking facilities. Alexandria, Va, Feb 1974.
- 1-10. U.S. Department of the Army. Technical Manual TM 5-258: Pile construction. Washington, D.C, Jun 1963.
- 1-11. U. S. Department of the Army. Technical Manual TM 5-360: Port construction and rehabilitation. Washington, D.C., Sept 1964.
- 1-12. Army Corps of Engineers. Guide specifications for civil works and for military construction, May 1976.
- 1-13. Federal Construction Council. Federal construction guide specifications. Washington, D.C.
- 1-14. American Association of Port Authorities. Port design and construction. Washington, D.C., 1964. (2d ed. published 1973 under title: Port planning, design and construction).
- 1-15. American Association of Port Authorities. Port maintenance. Washington, D.C., 1970.
- 1-16. Naval Facilities Engineering Command. NAVFAC MO-322: Inspection for Maintenance

Reference-1

of Public Works and Public Utilities, vol. 1, Alexandria, Va, Nov 1974.

1-17. Naval Facilities Engineering Command. NAVFAC MO-124: Mooring maintenance. Alexandria, Va, Dec 1973.

1-18. Naval Facilities Engineering Command. Design manual NAVFAC DM-7: Soil mechanics, foundations and earth structures. Washington, D.C., Mar. 1971.

1-19. U. S. Department of the Army. Technical Manual TM 5-818-1: Engineering and design: Procedures for foundation design of buildings and other structures (except hydraulic structures). Washington, D.C., Aug 1961. (AFM 88-3, chap 7).

1-20. U. S. Department of the Army. Technical Manual TM 5-818-5: Dewatering and groundwater control for deep excavations. Washington, D.C., Apr 1971. (AFM 88-5, chap 6; NAVFAC P-418).

1-21. U. S. Department of the Army. EM 385-1-1: General safety requirements. Washington, D.C, Mar 1967.

1-22. Naval Facilities Engineering Command. NAVFACINST 5100.11A: Command policy and program for safety. Alexandria, Va, July 1971.

1-23. U. S. Department of the Air Force. Manual AFM 127-101: Industrial safety accident prevention handbook, Washington, D.C., June 1970.

2-1. Naval Facilities Engineering Command. AVFAC MO-310: Military entomology operational handbook. Washington, D.C., Dec. 1971.

2-2. Naval Facilities Engineering Command. NAVFAC MO-312: Wood preservation. Washington, D.C., Jan. 1968.

2-3. National Fire Protection Association. Standard 87: Construction and protection of piers and wharves. Boston, Mass., 1971.

2-4. Civil Engineering Laboratory. Techdata Sheet TDS 76-13: Inspection methods for wood fender and bearing piles. Port Hueneme, Calif., Sept 1976.

3-1. Civil Engineering Laboratory. Techdata Sheet TDS 77-02: Epoxy resin for repairing cracked concrete. Port Hueneme, Calif., Jan 1977.

3-2. American Concrete Institute. Committee 506. Shotcreting. Detroit, Mich., 1966. (ACI SP-14)

3-3. ACI Committee 506: "Recommended practice for shotcreting," American Concrete Institute, Journal, Proceedings, vol. 63, no. 2, Feb 1966, pp. 219-246. Discussion. vol 63, no-9, Sept. 1966, pp. 1013-1016.

3-4. American Railway Engineering Association. "Shotcrete," in Manual for railway engineering, chap. 8, pt. 13. Chicago, Ill., 1973, pp. 8-13-1 through 8-13-7.

3-5. NAVFAC Notice 11012 of 9 Jan 1970. Pumping of concrete in aluminum pipe prohibited, Washington, D. C..

3-6. Civil Engineering Laboratory. Technical Report R-271: Epoxy sealers and bonding agents for concrete, by R. L. Alumbaugh, Port Hueneme, Calif., Mar. 1964. (AD 434197)

Reference-2

3-7. ACI Committee 403: "Guide for use of epoxy compounds with concrete," American Concrete Institute, Journal, Proceedings, vol. 59, no. 9, Sept. 1962, pp. 1121-1142. Discussion, vol. 59, Mar. 1963, pt. 2, pp. 2015-2018.

3-8. ACI Committee 504. "Guide to joint sealants for concrete structures, chap. 7. Performance defects, repair, and maintenance of sealants," American Concrete Institute, Journal. Proceedings, vol. 67, no. 7, July 1970, pp. 525-528.

3-9. ACI Committee 515: "Guide for the protection of concrete against chemical attack by means of coatings and other corrosionresistant materials," American Concrete Institute, Journal, Proceedings, vol. 63, no. 12, Dec. 1966, pp. 1305-1392.

4-1. Portland Cement Association. Structural Bureau. Publication ST50. Restoring old stone masonry by pressure grouting, Chicago, 111., 1948.

4-2. D. W. Cole. "Stabilizing constructed masonry dams by means of cement injections" American Society of Civil Engineers, Transactions, vol. 101, 1936, pp. 714-751; discussion, vol. 101, 1936, pp. 752-766.

4-3. H. Hurst. "Pressure grouting damp masonry by the injection of latex-siliconate compositions," Rubber Developments, vol. 21, no. 1, 1968, pp. 37-43.

5-1. Army Engineer Waterways Experiment Station. Miscellaneous Paper H-74-2: Concrete armor units for protection against wave attack, edited by R. Y. Hudson. Vicksburg, Miss., Jan. 1974.

6-1. Naval Facilities Engineering Command. NAVFAC

MO-330: Materials testing. Washington, D. C., Feb 1971.

6-2. TM 5-530 (Army's designation for Reference 6-1).

6-3. AFM 89-3 (Air Force's designation for Reference 6-1).

6-4. American Society for Testing and Materials. Standard D424-59 (Reapproved 1971): Standard method of test for plastic limit and plasticity index of soils. Philadelphia, Pa., 1971.

6-5. American Society for Testing and Materials. Standard D42366 (Reapproved 1972): Standard method of test for liquid limit of soils. Philadelphia, Pa., 1972.

6-6. American Society for Testing and Materials. Standard D42761 (Reapproved 1974). Standard Method of test for shrinkage factors of soils. Philadelphia, Pa., 1974.

6-7. American Society for Testing and Materials. Standard D69858T: Standard Method of test for moisture-density relations of soils using 5.5-lb (2.5-kg) hammer and 12-in. (304.8-mm) drop. Philadelphia, 6-8. 1958. (Superseded by D 698-70) 6-8. American Society for Testing and Materials. Standard D155758T: Standard method of test for moisture-density relations of soils using 10-lb (4.5-kg) hammer and 18-in. (457-mm) drop. Philadelphia, Pa., 1958. (Superseded by D 1557-70)

6-9. U. S. Department of the Army. Technical Manual TM 5-8186: Grouting methods and equipment. Washington, D.C., Feb 1970.

Reference-3

7-1. Naval Facilities Engineering Command. NAVFAC MO-306: Corrosion prevention and control. Washington, D. C., June 1964.

7-2. National Association of Corrosion Engineers. NACE Basic Corrosion Course: Houston, TX, Apr 1971.

7-3. Naval Facilities Engineering Command. NAVFAC MO-110: Paints and protective coatings: Washington, D. C., Jan. 1969. (Joint Service). (Army TM5-618; Air Force AFM85-3).

7-4. J. D. Keane, ed. Steel structures painting manual, vol 2. Systems and specifications, 2d ed. Pittsburgh, Pa., Steel Structures Painting Council, 1964.

7-5. U. S. Department of the Air Force. Manual AFM 88-15: Guidance on surface preparation for painting of steel. Washington, D. C., Jan 1975, Attachment 9.

7-6. Naval Facilities Engineering Command. Type Specification TS 15057: Coal tar coating systems for steel surfaces. Washington, D. C., Apr. 1974.

7-7. R. W. Drisko. "Zinc-rich coatings for marine application," Materials Protection, vol. 9. no. 3, Mar. 1970, pp. 11-12.

7-8. W. D. Parker and W. H. Yeigh. "Petrolatum coated tapes for marine use," Materials Protection and Performance, vol. 11, no. 11, Nov. 1972, pp 31-33.

7-9. C. M. Wakeman, J. W. Storer, and O. E. Liddell. "179 years in sea water?" Materials Protection and Performance, vol. 12, no. 1, Jan. 1973, pp. 14-17.

7-10. R. W. Drisko. "Underwater marine applications of coatings and adhesives," Journal of Paint Technology,

vol. 47, no. 600, Jan. 1975. pp 40-42.

7-11. Naval Facilities Engineering Command. NAVFAC MO-110.1: Facilities engineering management of maintenance painting of facilities. Alexandria, Va, Oct 1973.

7-12. Civil Engineering Laboratory. Techdata Sheet 74-11: Field measurement of paint film thickness. Port Hueneme, Calif., Nov. 1974.

7-13. Naval Facilities Engineering Command. NAVFAC MO-307: Corrosion control by cathodic protection. Washington, D. C., June 1964.

7-14. U. S. Department of the Air Force. Manual AFM 88-9, Chap. 4: Corrosion control. Washington, D.C. Aug 1962.

7-15. Civil Engineering Laboratory. Technical Report R-365: Plastic mooring buoys, pt. 1. Fabrication of experimental models, by R. W. Drisko and T. Roe. Port Hueneme, Calif, Mar 1965 (AD 612055)

7-16. Civil Engineering Laboratory. Technical Report R-750: Urethane foams for Navy pontoon structures, by R. W. Drisko. Port Hueneme, Calif., Nov 1971 (AD 736596)

7-17. Naval Facilities Engineering Command. NAVFAC MO-220: Maintenance and operation of gas systems (triserice). Alexandria, Va, Nov 1970. (AFM 91-6; Army TM 5-654)

7-18. Civil Engineering Laboratory. Techdata Sheet 75-26: Protection of fuel lines under piers. Port Hueneme, Calif., Oct 1975.

Reference-4

7-19. Civil Engineering Laboratory. Techdata Sheet 75-30S: Piping and Conduit for Navy Fuel Piers. Port Hueneme, Calif., Feb 1976.

8-1. S. S. Oleesky and J. G. Mohr. Handbook of reinforced plastics of the society of the plastics industry, Inc., New York, Reinhold, 1964.

8-2. Civil Engineering Laboratory. Techdata Sheet 75-4: Urethane foams for Navy flotation use. Port Hueneme, Calif., Mar 1975.

8-3. Civil Engineering Laboratory. Techdata Sheet 74-12: In-place protection of wooden bearing piles damaged by marine borers Flexible Poly (vinyl chloride)

(PVC) barriers. Port Hueneme, Calif., Dec 1974.

8-4. Civil Engineering Laboratory. Techdata Sheet 75-2: In-place protection of marine borer damaged wooden bearing piles Reinforced mortar filled sleeve barriers. Port Hueneme, Calif., Mar 1975.

8-5. Civil Engineering Laboratory. Techdata Sheet 75-10: Adhesives for use underwater. Port Hueneme, Calif., May 1975.

B-1. Naval Sea Systems Command. Naval ships technical manual, chap. 9190: Preservation of ships in service (paints and cathodic protection). Washington, D.C., Jan 1970. (NAVSEA 0901-LP-190-0002).

Reference-5

GLOSSARY

Alligatoring	Intersecting cracks and ridges in weathered coatings that give an appearance of an alligator hide.
Anode	The consumable component (electrode) of cathodic protection systems and corrosion cells.
Apron	That portion of a wharf or pier carried on piles beyond solid fill.
As-built drawings	Drawings that show all deviations from the original design and changes made during construction.
Ashlar	Sawed or dressed square stones used in facing masonry walls.
Bench mark	A mark on a fixed and enduring object indicating a particular elevation. It is used as a reference in topographic surveys, tidal observations, and construction.
Bent	Framework crosswise to the length of a structure (e.g., trestle, bridge, or pier) which it supports; usually designed to support stringers.
Berth	The water area at the edge of a wharf or pier reserved for a vessel.
Bitt	A single or double-posted steel fitting on a deck of a ship or pier to which mooring lines are secured (see Figure 7-6).
Bollard	A single or double-posted steel fitting on a pier or wharf around which mooring lines from vessels are tied (see Figure 7-6).

Glossary-1

Breakwater	A substantial structure, located at the outer limits of a harbor or anchorage, to protect the inner waters against the effects of heavy seas (see Figure 1-10).
Breast board	A temporary barrier or retaining board used to prevent the face of an excavation caving in.
Brow	A portable walk or bridge between ship and pier, or landing platform for use of personnel while the ship is berthed. It is usually equipped with handrails and has rollers on the shore end.
Bulkhead	A retaining wall to prevent sliding of earth or fill into water.
Bullrail	A guard, usually wooden, located along the outer edge of a wharf or pier to prevent accidental loss of equipment into the water.
Buoy	A float moored to the bottom to mark the position of a shoal, channel, or anchorage limit, or a floating component of a ship mooring.
Caisson	(1) A supporting foundation (dam) formed by pouring concrete, driving sheet lock piling, or forming other material into a hollow box or cylinder; allows maintenance and repair work to be done below water level. (2) A controlled submergence floating hull used as a watertight entrance closure for a graving dock.
Camel	A floating device acting as a fender and used to separate a moored vessel from a pier, wharf, quay, or other vessels.
Cap	(1) A horizontal timber secured to the top of a row of piles. (2) A fitted or threaded piece to protect the top of a pile from damage while being driven.
Cathodic protection	An electrical method of preventing metal corrosion in a conducting medium by placing a charge on the item through a transformer or a sacrificial anode.
Chock	(1) A wedge or block, commonly wooden, fitted between piling or other structures to steady them. (2) A metal casting with two horn-shaped arms curving inward between which mooring lines may pass; used for passage, guiding, or steadying of mooring or towing lines. (See Figure 7-6).

Glossary-2

Cleat	A metal fitting on the deck of a pier or ship usually with two projecting horns around which a rope may be made fast (as by belaying it) (see Figure 7-6).
Cobblestone	A naturally rounded stone.
Cofferdam	A temporary watertight enclosure from which water is pumped to expose normally immersed areas.
Cold iron	Capability or service supplied to a docked ship so that necessary utilities (e.g., steam, water, electricity, sewage removal, telephones) are provided from shore rather than from the power plant on the ship.
Concrete armor unit	See dolos, tetrapod, and tribar.
Cradle	A platform with keel and bilge blocks for holding ships.
Curb	See bullrail.
Deadman	A block or other heavy item, usually of concrete, buried in the ground to which is attached a steel rod or cable for anchoring objects.
Deck	The working surface of a wharf, pier, or vessel.
Dock	The water area adjacent to a wharf or pier to which a ship can be secured.
Dolos	A concrete armor unit used for riprap (see Figure 5-1).
Dolphin	A structure usually consisting of a cluster of timber piles. It is placed at the outward end of piers and wharves, or along shore, to guide vessels into their moorings, to fend vessels away from structures, shoals, or the shore, or to support navigation aids.
Dolomite	Limestone or marble rich in magnesium carbonate.
Drydock	A facility for exposing the normally underwater portion of a ship for construction, inspection, repair, or hull maintenance.

Glossary-3

Elastomer	An elastic rubber-like substance (such as a synthetic rubber or a plastic having some of the physical properties of natural rubber).
Electrolyte	A nonmetallic medium capable of conducting electricity by the movement of ions rather than electrons.
Electroosmosis	The movement of a conducting liquid (such as water in clay) through a porous diaphragm under the action of an electromotive force applied to electrodes on opposite sides of the diaphragm.
Estuary	A water passage where the tide meets a river current, especially an arm of the sea at the lower end of a river.
Fender	A device, usually of wood, rubber, or rope to prevent damage to a vessel or shore facility by impact or abrasion.
Filter blanket	A layer or progressively graded series of soil layers, or plastic cloth filter woven of synthetic fibers, separating material of different grain size. The separation prevents the fine soil from entering into the open spaces of the coarser one.
Fire curtain wall (fire stop)	A transverse wall under a pier which extends from the underside of the decking to low water to contain a fire. (Each side of wood or metal fire curtain wall is protected by automatic sprinklers or deck openings for use of revolving water nozzles.)
Fish plate	A steel plate that laps a joint (see Figure 7-7) or an area of a piling reduced by corrosion. It is secured to the sides so as to connect the members end to end or to strengthen them.
Float	A floating platform used for disembarking from a boat or working around waterfront structures.
Floating drydock	A ship or U-shaped structure in cross section that can be submerged by flooding to permit a vessel to enter and then be dewatered to raise the vessel supported on keel and bilge blocks out of the water.
Fouling	An accumulation of deposits, especially marine biological growth.

Glossary-4

Gad	A pointed iron or steel bar for loosening rock.
Gravity wall	A massive structure that obtains stability through its own weight.
Graving dock	A fixed basin of usually either stone masonry, reinforced concrete, or sheet piling cells near the water's edge. It can be closed off from the waterway by a movable watertight barrier, usually a floating caisson (see Figure 1-4).
Groin	A narrow structure projecting out, usually close to right angles, from the shoreline (Figure 1-11). It is designed to influence offshore currents and wave action in a manner that will minimize erosion of the shoreline.
Holiday	A small hole in a coated surface arising from imperfect application.
Hyphal threads	A filament outgrowth of fungus.
Incise	To make cuts into wood parallel to the grain to permit the take up of greater quantities of preservative.
Jetty	A structure (such as a mound or wall) at or near the entrance to a harbor or river constructed to confine the flow of water due to currents and tides, and to maintain the entrance free of sandbars (Figure 1-9).
Leaching	The process of extracting the soluble components from a material by percolation.
Littoral drift	Movement of sediment by underwater currents and tidal action, usually resulting in formation of sandbars.
Marine railway	An inclined groundway extending into the water, with a mobile cradle that moves on the groundway tracks, for hauling a ship out of or into the water.
Marine borer	Destructive organism in seawaters that attacks untreated or poorly treated wood; especially active in warm waters.

Glossary-5

Mill scale	Oxide layer formed on iron and steel when heated for rolling, forging, or other processing.
Mole	A rubble-mound structure that extends outward from shore into the navigable water of a harbor (Figure 1-8). Generally, the level top is appreciable in area and contains paved roads, railroads, and crane trackage.
Mound	An artificial embankment or ridge composed of sand, gravel, and cobbles and constructed on the ocean floor by dumping the material from scows and barges.
Pier	An open- or closed-type structure usually extending perpendicularly from the shore into sheltered navigable water, designed for berthing, loading or unloading cargo, repair, fueling, and general servicing of vessels. It normally provides berthing space on both sides for its entire length (see Figure 1-1).
Piezometer	An instrument for measuring pressure or compressibility.
Pile (piling)	A long, slender timber, steel, or reinforced concrete structural element driven, jettied, or otherwise embedded into the ground to support a vertical load, to resist a lateral force, or to resist water or earth pressure.
Potable	Suitable for drinking.
Preservative	A material with the property of retarding deterioration.
Quarrystone	A diamond or square cut stone.
Quay	See wharf.
Quaywall	A heavy structure fronting on navigable water, and parallel to the shore, behind which earth fill is placed. Its function is to act as a bulkhead as well as to provide for berthing of vessels or other service.
Radiography	The process of making a picture upon a sensitive surface by a form of radiation other than light. It is used for detecting flaws in welds and other metal structures.

Glossary-6

Relieving platform	A platform built on piling or other support structures to carry fill to support surface structure.
Rubble	Rough and uncut stones, irregularly shaped and of various sizes ranging up to 1,000 cu ft each and up to 90 tons each.
Riprap	Stones, boulders, or concrete armor units of miscellaneous size placed without order on the surface of an earthen structure or embankment to act as protection against erosion.
Seasoning check or crack	A lengthwise separation of a wooden timber that extends across the rings of annual growth and commonly results from stresses set up in the wood during seasoning.
Seawall	A massive gravity-type structure built along, and generally parallel to, the shoreline; designed to protect the shore against erosion resulting from wave action.
Sheepsfoot roller	A roller with spikes inserted to compact, perforate, or scarify the rolled surface.
Shoreline	The boundary area where water meets land.
Shotcrete	Shotcrete or gunite is a concrete that is pneumatically placed in layers usually from 1 to 2 inches. Water is mechanically added to the dry mixture at the nozzle, which shoots the freshly mixed concrete (really a mortar) at the surface prepared for its reception.
Stringer	A horizontal framing member used to support a floor or deck.
Syntactic foam	A foam composed of hollow spheres in a resin matrix.
Tetrapod	A nonreinforced concrete armor unit used for riprap (see Figure 5-1).
Traprock	Fine-grained igneous rock.
Tremie	A steel tube 12 inches or greater in diameter used for depositing concrete underwater, having at its upper end a hopper for filling.
Tribar	A reinforced concrete armor unit used for riprap (See Figure 5-1).

Glossary-7

Tuck-point	To finish the joints between masonry units with a narrow ridge (bead) of mortar. Pointing mortars usually shrink after placement and if finished flush with the masonry units will result in a concave joint.
Turning basin	An enlarged space at the end of a canal or narrow channel to permit vessels to turn around.
Ultrasonic testing	High frequency sound readings to determine voids in landfills, flaws in welds, etc.
Vertical lift	A platform which is lowered into the water to receive a small vessel and then elevated out of the water by hoisting equipment (see Figure 1-6).
Wale	A long, horizontal structural member of timber or steel used for bracing vertical members. Also known as "waler" or "ranger."
Weep hole	An opening in a retaining wall, canal lining foundation, or other structure to drain away accumulated water.
Wharf	An open-type marginal platform structure, usually parallel to the shoreline, that is used primarily for berthing of vessels. It is usually connected to the shore at more than one point but may also have continuous access along the shore. It ordinarily provides berthing along the outboard face (see Figure 1-2).

Glossary-8

Appendix A

DIVER INSPECTION OF STRUCTURES

INTRODUCTION

This appendix is a brief summary of procedures for locating and assessing damage to underwater structures.

Underwater inspection requires the use of diving equipment. Hardhat diving equipment provides good stability in flowing water and good protection from a dangerous bottom, moving debris, and/or sharp fouling organisms, but affords less freedom of movement. Scuba equipment does not provide such protective clothing, but permits faster inspection because of greater mobility. A hardhat diver should remain in constant contact via a two-way telephone with an assistant topside who relays instructions and data between the inspector and the diver and provides necessary diver support. A scuba diver usually surfaces to communicate findings to the inspector or engineer; however, communication by radio telephone is preferable. Closed-circuit underwater television equipment (especially with facilities for tape recording) can be of great value. Underwater photography may also be useful for documentation.

All fouling organisms, rust, and other surface contaminants must be removed before a close-up inspection of underwater surfaces can be made. This is usually done at spot locations rather than cleaning an

entire structure. The preference for a raft or boat for handling diver and inspection equipment (if both are available) depends upon the calmness of the waters and the need for mobility, as well as other job requirements.

An engineer and activity representative should be present whenever underwater inspections are made. They are necessary to explain to the diver exactly what should be found, i.e., number and size of piles, type and depth of bulkheads, location of tiebacks, cross bracing, etc. The engineer shall evaluate the diver's observations, determine the degree-of-hazard, and recommend repairs.

The following general diver equipment is necessary:

- Portable flashlight
- Special sampling equipment (see Table A-1)
- Writing slate
- Air-powered scrapers or wire brushes for removal of fouling, rust, silt, etc.
- Easy-to-read measuring tape
- Wrecking bar
- Probe, such as sharp ice pick
- Knife, hand scraper, and hammer
- Sounding gear for determining depth and other measuring devices

The activity shall provide as-built drawings previous inspection reports, or other information that will assist the diver and engineer in locating critical areas or areas at which damage had previously been noted.

Table A-1 identifies special inspection equipment, visual observations, and measurements, ratings, or samplings required for inspecting structures made of different construction materials.

Table A-1. Inspection of Specific Structures

Construction Material	Special Sampling Equipment	Visual Observations	Measurements, Ratings, or Samplings
Wooden	Calipers for determining piling diameter Sonic equipment for detecting hollow areas in piling Increment borer for determining quality of preservative or soundness of piling Treated wooden plugs for holes left after boring	Breaking or cracking from impact or overload Detection of <i>Limnoria</i> or teredine siphons on surface Areas of reduction of piling diameter from abrasion or marine borer attack Areas of riddled or lost wood Condition of pile barriers Diameter/condition of fasteners (bolts, etc.), cables, wraps	Piling diameter Location and size of damaged areas Depth of cracks and other damaged areas Rating of piling condition Data from sonic equipment Wood samples or increment borings
Concrete	Hammer Chipping tool Concrete-core rotary drilling equipment Sonic or ultrasonic equipment for detecting voids Power source	Chipping, cracking, spalling, and disintegration Rust spots Condition of exposed steel Joint conditions Bottom scouring, undermining	Location and size of damaged areas Depth of chips, cracks, spalls, etc. Drilled concrete cores Sonic or ultrasonic data
Stone masonry ^b		Chipping, cracking, abrasion damage Settlement and horizontal displacement Erosion of soil through joints or cracks	Location and size of damaged areas Depths of chipped, cracked, or abraded areas
Rubble-mound		Erosion of core material by wave action Erosion of small stones in riprap Stability of armor stones or blocks Breakage and displacement of concrete armor elements Washing out of substrate at the toe of structures	Location and size of damaged areas Slope of structure

continued

Table A-1. Continued.

Construction Material	Special Sampling Equipment	Visual Observations	Measurements, Ratings, or Samplings
Rubble-mound (con't)		Undermining of foundation High water mark; overtopping Settling of structures	
Structures involving soil		Erosion of foundation or slopes Subsidence of soil because of lost backfill through cracks or holes in bulkheads, etc.	Location and size of damaged areas
Steel	Scale or calipers for determining thickness Ultrasonic equipment for determining thickness Equipment for measuring electric potentials on cathodically protected steel Pit gage Equipment for patching holes cut into steel structures by impact Power source	Coating condition (peeling, blistering, erosion, etc.) Condition of cathodic pro- tection equipment (broken or corroded conduits, loose wires, lost anodes, etc.) Extent of corrosion Type of corrosion (density, pitting, etc.) Members structurally damaged potentials Open seams or holes in quay- walls, etc Soil subsidence because of lost backfill through seams or holes Inspection of welds	Metal thickness Location and size of damaged areas Depth of pits and extent of their occurrence Samples of corrosion products or damaged coatings Cathodic protection Deformation of structural members

^aThe diver notes the diameter loss (which is later classified as shown in Figure A-1), whether damage is general or localized at a particular depth, and unusual conditions prevailing.

^bInteriors of graving docks are ordinarily inspected at a time when the docks are empty. Divers are required to inspect aprons or entrance settlement and condition of approaches.

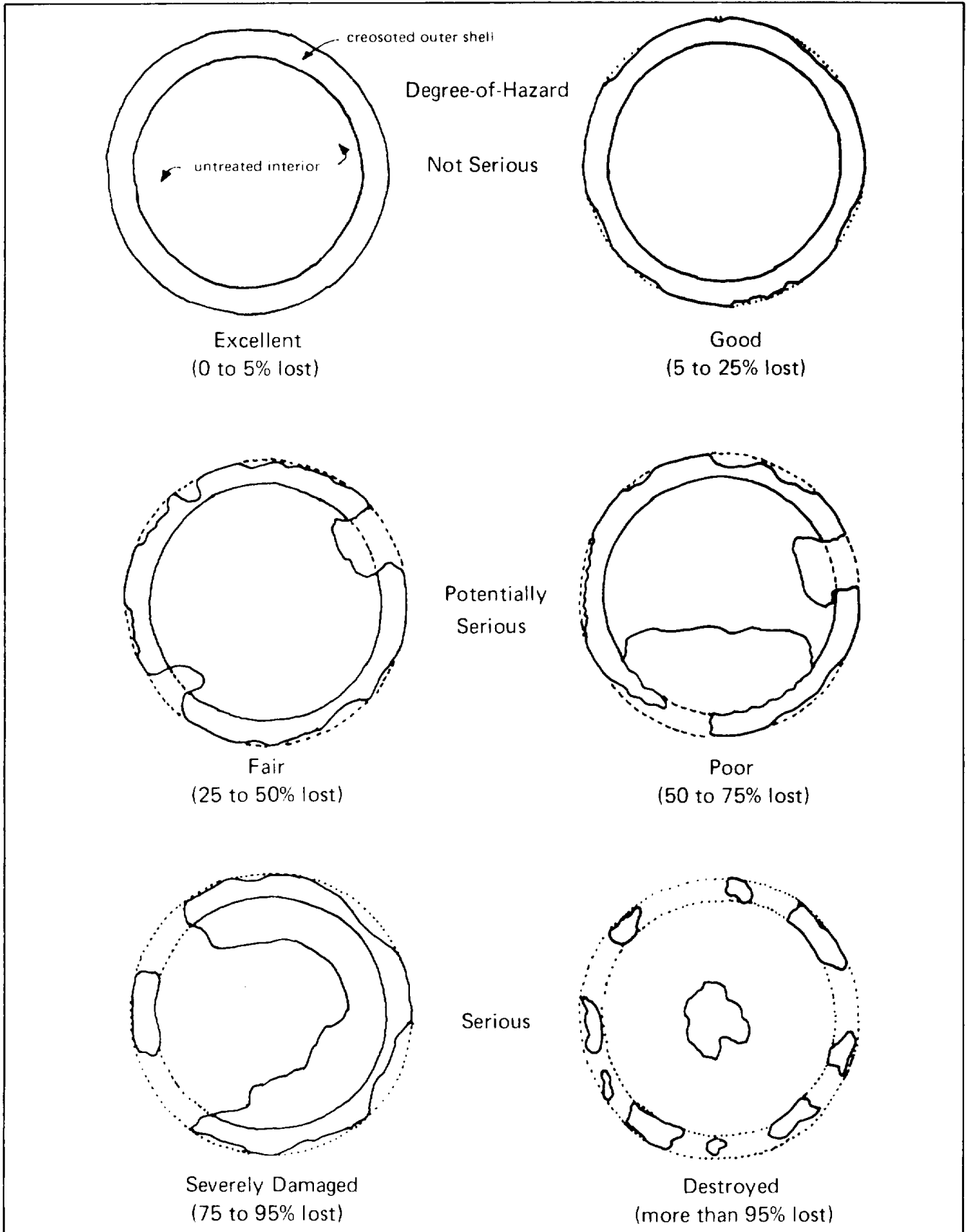

Figure A-1. Cross section of piles with different damage ratings.

Appendix B

INSPECTION, DOCUMENTATION, MAINTENANCE, AND CERTIFICATION OF GRAVING DOCKS

INTRODUCTION. Detailed information is given in this appendix for inspecting, reporting, maintaining, and, specifically, certifying graving docks, because this information is no longer covered in a maintenance and operation manual.

SCHEDULING. It is not necessary for all parts of a dock to be inspected simultaneously. Each item shall be inspected at least once each year, except for machinery, such as pumps and capstans (see Table B-1 for detailed scheduling). Machinery that must be opened for inspection should be scheduled for inspection at a time when it will not interfere with the docking schedule. Advantage shall be taken of routine pumping and flooding of the dock and caisson to inspect the machinery and equipment while they are in operation.

DOCUMENTATION. The following documents shall be made available for study and use by the inspectors:

- (1) Previous reports of preventive maintenance inspections and control inspections.
- (2) Copies of correspondence relative to correction of deficiencies that were initiated or received since the last inspection.

- (3) Copies of correspondence relative to matters affecting the capabilities of the dock or its material readiness.

- (4) Reports of machinery derangements and casualties to material.

- (5) Operational logs, if any, of the dock and its equipment.

- (6) Operation manuals for the equipment.

- (7) A record of repairs or improvements effected on machinery.

- (8) Prints or drawings of the structure and utilities of the dock. Plans and as-built specifications, when available.

Each activity shall prepare a Preventive Maintenance (PM) Manual for the mechanical equipment (pumps, sluice gates, valves, ventilation, etc.) for each graving drydock. The Manual should include but is not limited to the following:

- (1) Location of all fittings.
- (2) Maintenance schedule for components, including description of work
- (3) Overhaul frequency for each piece of equipment (varies between 2 and 10 years)

- (4) Type, age, and manufacturer of installed equipment
- (5) Equipment usage and reliability histories
- (6) Backup equipment available
- (7) Notes on overall condition and impact of failure

INSPECTION. Table B-2 lists specific items to inspect. The inspectors shall observe the following procedures when making these inspections.

(1) Thoroughly inspect every part of the drydock and every item of machinery and equipment to determine its condition (see Figure B-1).

(2) Make free use of hammers for sounding rivets, bolts, plates, and other parts, and of scrapers for removing paint to disclose metal surfaces. Use probes to determine the soundness of timber structures. Hammers can be used to examine defective areas on concrete surfaces.

(3) Pay particular attention to leaks, and note if any materials are being carried in suspension.

(4) Pay particular attention to the possibility of settlement of the drydock or adjacent land.

(5) Take soundings outboard of entrances to determine whether there are any large holes or raised areas that might indicate movement of earth from or development of water-ways under the drydock floor.

(6) Note any evidence of undue stress in caisson structure, such as sprung plates, leaky rivets, or bent frames, caused by unequal drydock settlement.

If feasible, cracks and other similar faults should be repaired or photographed to determine the rate of

progressive failure.

MAINTENANCE. Preventive maintenance is primarily concerned with items that, if disabled, would (1) interfere with an essential operation of the graving drydock, (2) endanger life and/or property, or (3) involve high cost or long lead time for replacement. Maintenance work must be scheduled to conform to the operating schedule of a drydock. Maintenance work which does not interfere with a dock operating schedule should be performed when necessary. The following are the principal elements of maintenance for a graving drydock:

(1) Patching cracks and grouting leaks in the concrete dock body, including filling and discharge culverts; weld repair of metal cracks and damaged metal.

(2) Cleaning, painting, and replacing metal guardrails, stanchions, gratings, and similar equipment.

(3) Repairing and replacing operating equipment (such as motors and controls, pumps, valves, and sluice gates) and utility equipment (such as air, water, steam, electric power, and sewage).

(4) Renewal of blocking.

(5) Cleaning and painting of the drydock entrance closures and seats, and repair and replacement of its operating equipment.

The coating systems recommended for maintenance painting of drydock components are listed in Table B-3. The methods for surface preparation and their application are described in Chapter 7 of this manual and in much greater detail in Reference 7-3 and

B-1. The latter gives detailed instruction for use of MIL-P-24441 listed in Table B-3.

CERTIFICATION. The objective of facility certification is to assure the safety of ships and personnel during docking and undocking operations and the safety of ships while in dock. This certification does not cover other requirements of the facility, such as compressed air, steam, electrical, and sewage services. Normally, the facility shall be certified for its maximum designed capacity. If the facility is certified for a loading of less than this amount, the reason for choosing this value shall be explained. The maximum designed capacity, unless otherwise stated, shall be based on a typical ship loading.

When required certification shall be submitted to the major Command with a copy to the appropriate headquarters for each facility every five years. In the event major changes are made to the facility within this five-year period, a revised certification application shall be submitted. As an option, a maintenance program providing for a continuous certification without frequent or regular resubmittals, except when significant changes are made, can be implemented, with the stipulation that:

(1) A formalized and implemented maintenance program exists and can be shown to be effective by audit.

(2) Operating procedures are maintained in current and self-correcting accuracy as shown by in-process audit.

(3) Control of design and other system changes are effected through a formalized and implemented Design (or change) Control Board and

shown to be effective by audit.

Facility certification shall be terminated as a result of the following:

- (1) Major overhaul or repair.
- (2) Broaching of the scope of the facility certification.
- (3) Expiration of tenure of facility certification.
- (4) Recognition of the existence of an unsafe condition.

After certification, the facility must remain in the "as certified" condition with full consideration being given to normal wear and tear for the period of certification.

The general requirements for certification are:

(1) Provide a description of the graving dock. The description must be based on the dock design as presently constructed, including modification to date. Provide data such as core borings and foundation data; description of foundation, longitudinal and transverse sections with appropriate elevations, and entrance closure; information on the performance and adequacy of the drydock pressure relief system; the effectiveness of the drainage features (blankets, filters, and underdrain); and irregularities which may indicate normal concentration of flow or subsurface erosion. Original historical data would only be provided when relevant to the present configuration.

(2) Provide a history of the successful operation of the graving dock over the last five years.

(3) Provide copies of Standard Operating Procedures for Docking and Undocking Vessels and

Standard Operating Procedures for Operating the Graving Docks.

(4) Where activity disaster plans and firemain certification tests have already been submitted, include copies for information only.

(5) An earthquake analysis shall be provided in areas subject to seismic events.

On the basis of the above information, a conditional certification of the facility will be given. Within the next three years, a professional engineer

team must conduct a material survey. The material survey shall include measurements for potential corrosion and cathodic protection. Upon receipt of the survey, the conditional acceptance will be made a full acceptance.

A material survey by an independent team shall be conducted at ten-year intervals. A yearly visual survey of each facility must be conducted by in-house personnel and a report submitted. If any material change occurs to the condition of the facility, the activity must notify the certification organization.

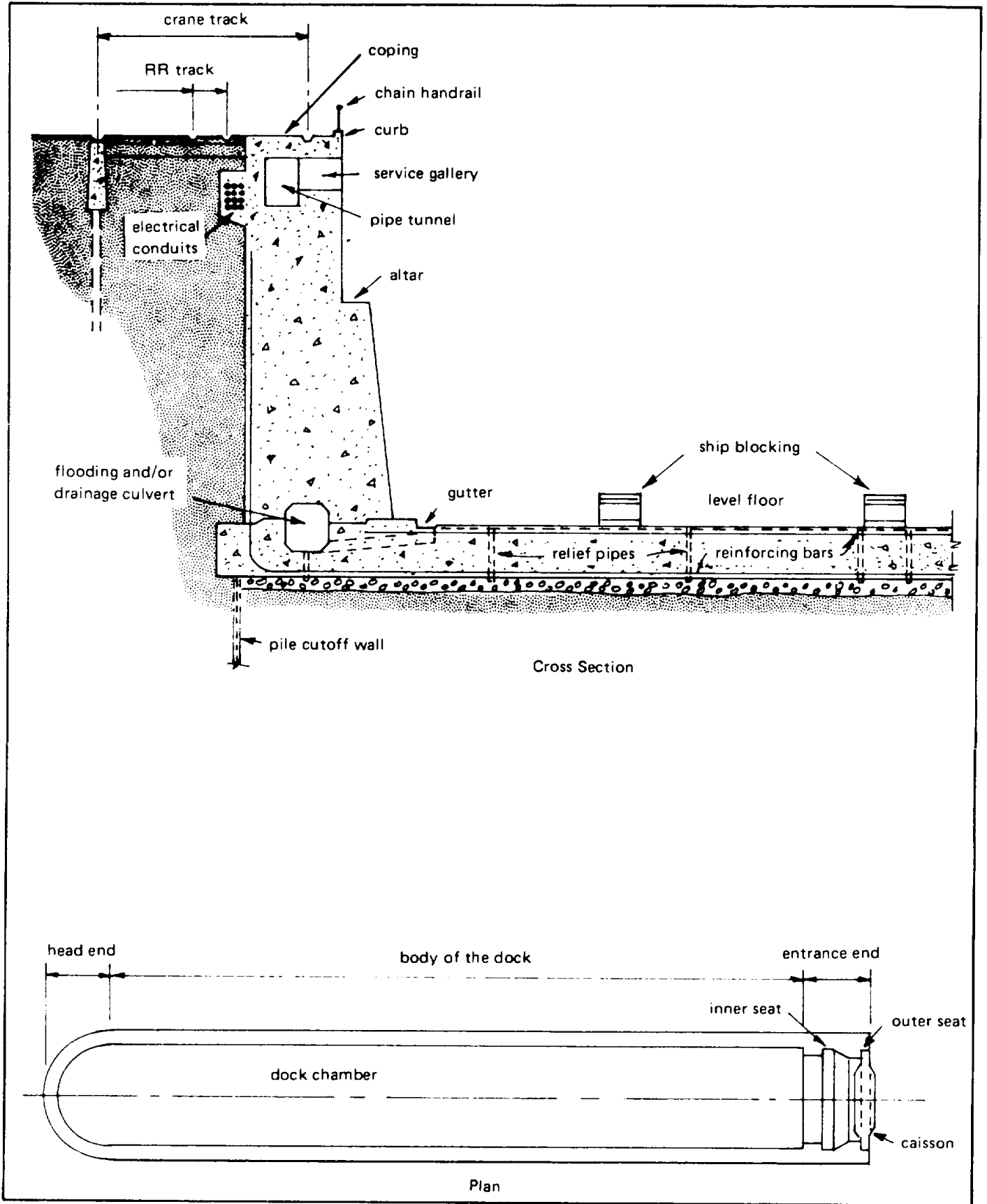

Figure B-1. Designation of drydock features.

Table B-1. Inspection Frequencies

Component	Preventive Maintenance Inspection	Control or Engineering Inspection	Component	Preventive Maintenance Inspection	Control or Engineering Inspection
Electrical:			Mechanical (cont'd):		
Communication equipment and controls	SA	A	Sewage and plumbing system:		
Distribution:			Fixtures	M	A
Transformers	-	A	Piping	M	A
Feeder and branch circuit switchgear	SA	A	Pumps	SA	A
Feeder and branch circuit wiring	-	A	Valves	SA	A
Electric heaters	SA	A	Shore-to-Ship service	Q	A
Lighting equipment and controls	SA	A	Weight handling equipment:		
Motors and motor controls	SA	A	Capstans	Q	A
Shore-to-Ship service	Q	A	Wheeler tank cleaning system	SA	A
Mechanical:			Miscellaneous mechanical equipment:		
Compressed air system:			Chains and sheaves for hauling blocks	Q	A
Air compressors	Q	A	Structural:		
Valves	SA	A	Basin	-	A
Dewatering and flooding systems:			Closure -	A	
Dewatering pumps	SA	A	Crane and railroad rails	-	A
Gates, sluice	SA	A	Drainage and filling tunnels	-	A
Mechanical water level and draft indicator	SA	A	Galleries and altars	-	A
Piping	-	A	Machinery pits	-	A
Vacuum pumps	SA	A	Miscellaneous fittings and accessories:		
Valves	SA	A	Air ports	-	A
Fresh water systems:			Blocking	-	A
Piping	-	A	Bollards and cleats	-	A
Valves	SA	A	Brows and gangways	-	A
Heating and ventilating systems:			Draft gages and marking plates		
Fans	Q	A	Gratings and cover plates	-	A
Piping (steam or hot water)	-	A	Handrails	-	A
Unit heaters and convectors	SA	A	Stairs and ladders	-	A
Valves and traps	SA	A	Stoplogs		
Ventilators and air ducts	-	A			
Salt water systems:					
Piping	-	A			
Valves	SA	A			

A = Annually.
 SA = Semiannually.
 Q = Quarterly.
 M = Monthly.

Table B-2. Inspection Checkoff List

Location _____ Sheet No. _____ of _____
 Dry Dock Size and Designation _____ Date _____

Graving Dry Dock No. _____

Items Inspected	Degree of Hazard*				Remarks (for additional remarks use other side)
	N	M	CR	CAT	
Basic Structure					
Coping					
Walls					
Galleries					
Altars					
Service tunnels					
Stairs and elevators					
Floor					
Apron					
Caisson seats					

_____ Signature of Inspector

- N = (Negligible) will not result in personnel injury or system damage. The system or subsystem(s) may be fully utilized. No action required.
- M = (Marginal) can be counteracted or controlled without injury to personnel or major system damage. Usage of the system or subsystem(s) may continue; however, routine maintenance or repair shall be scheduled.
- CR = (Critical) will cause personnel injury or major system damage, or will require immediate corrective action for personnel or system survival. The system or subsystem(s) may continue to be used at the discretion of the commanding officer provided appropriate restrictions are enforced and additional inspections are conducted to check the defect(s).
- CAT = (Catastrophic) will cause death or severe injury to personnel, or system loss. The system or subsystem(s) shall NOT be used until repaired. When necessary to use systems in this category, the commanding officer shall be responsible for safety, and his assigned representative shall supervise each operation involving the system. Temporary or emergency repair may reduce the category-of-hazard, depending on the severity of the defect and based on an engineering evaluation.

Note: Degree-of-hazard categories based on MI L-STD-882.

Inspection Checkoff List (cont'd)

Sheet No. _____ of _____

Graving Dry Dock No. _____

	Degree of Hazard				Remarks (for additional remarks use other side)
	N	M	CR	CAT	
Drainage culverts					
Drainage tunnels					
Filling tunnels					
Discharge tunnels					
General appearance					
Pressure relief systems					
Fittings					
Portable guardrails					
Cleats					
Bollards					
Roller chocks					
Handrails					
Gratings					
Crane track					
Draft gages					
Blocking					
Keel blocks					
Bilge blocks					
Hauling bilge blocks					

_____ Signature of Inspector

Inspection Checkoff List (cont'd)

Sheet No. _____ of _____

Graving Dry Dock No. _____

Items Inspected	Degree of Hazard				Remarks (for additional remarks use other side)
	N	M	CR	CAT	
Services					
Compressed air piping and valves					
Corrosion protection features					
Mechanical Equipment					
Capstan No.					
1 2 3 4 5 6 7 8 9					
Sluice Gates					
Sluice gate leaf					
Sluice gate guides					
Sluice gate operator					
Sluice gate controller					
Hydraulic operating gear					
Lubrication system					
Preservation					
Check Valves					
Valve leaves					
Swing mechanism					
Nonslam mechanism					
Lubrication					
Preservation					

_____ Signature of Inspector

Inspection Checkoff List (cont'd)

Sheet No. _____ of _____

Graving Dry Dock No. _____

Items Inspected	Degree of Hazard				Remarks (for additional remarks use other side)
	N	M	CR	CAT	
Stoplogs or Gate					
Guide slot					
Log or gate body					
Hoisting equipment					
Preservation					
Intake screen					

_____ Signature of Inspector

Items Inspected	Degree of Hazard				Remarks (for additional remarks use other side)
	N	M	CR	CAT	
Basic Structure					
Shell plating					
Structural framing					
Bulkheads					
Deck plating					
Top dock covering					
Fenders					
Wood backing for gasket					
Rubber gasket					
Exterior preservation					
Interior preservation					
Ballast compartment preservation					
General condition					
Fittings					
Portable guardrails					
Hatches					
Cleats, chocks					
Steps, ladders, handrails					
Gratings					
Airports					

_____ Signature of Inspector

Caisson No. _____

Items Inspected	Degree of Hazard				Remarks (for additional remarks use other side)
	N	M	CR	CAT	
Compressed air piping					
Compressed air container valves					
Inclinometers					
Water level indicators					
Lighting fixtures					
Mechanical Equipment					
Capstan no. 1					
Capstan motor					
Motor controller					
Capstan no. 2					
Capstan motor					
Motor controller					
Dewatering pump no. 1					
Pump motor					
Motor controller					
Lubrication system					
Foot valve					
Discharge valve					
Valve operator					
Check valve					

_____ Signature of Inspector

Items Inspected	Degree of Hazard				Remarks (for additional remarks use other side)
	N	M	CR	CAT	
Dewatering pump no. 2					
Pump motor					
Motor controller					
Lubrication system					
Foot valve					
Discharge operator					
Check valve					
Trimming Pump No. 1					
Pump motor					
Motor controller					
Discharge valve					
Trimming Pump No. 2					
Pump motor					
Motor controller					
Discharge valve					
Flood Valves					
Flood valve no. 1					
Valve operator					
Flood valve no. 2					
Valve operator					

_____ Signature of Inspector

Caisson No. _____

Items Inspected	Degree of Hazard				Remarks (for additional remarks use other side)
	N	M	CR	CAT	
Flood valve no. 3					
Valve operator					
Flood valve no. 4					
Valve operator					
Flood valve no. 5					
Valve operator					
Flood valve no. 6					
Valve operator					
Flood valve no. 7					
Valve operator					
Flood valve no. 8					
Valve operator					
Flood valve no. 9					
Valve operator					
Flood valve no. 10					
Valve operator					
Flood valve no. 11					
Valve operator					
Flood valve no. 12					
Valve operator					

_____ Signature of Inspector

Caisson No. _____

Items Inspected	Degree of Hazard				Remarks (for additional remarks use other side)
	N	M	CR	CAT	
Flood valve no. 13					
Valve operator					
Flood valve no. 14					
Valve operator					
Flood valve no. 15					
Valve operator					
Flood valve no. 16					
Valve operator					
Flood valve no. 17					
Valve operator					
Flood valve no. 18					
Valve operator					
Flood valve no. 19					
Valve operator					
Flood valve no. 20					
Valve operator					
Flood valve no. 21					
Valve operator					
Flood valve no. 22					
Valve operator					

_____ Signature of Inspector

Items Inspection	Degree of Hazard				Remarks (for additional remarks use other side)
	N	M	CR	CAT	
Flood valve no. 23					
Valve operator					
Flood valve no. 24					
Valve operator					
Flooding valve no. 1					
Valve operator					
Flooding valve no. 2					
Valve operator					
Flooding valve no. 3					
Valve operator					
Flooding valve no. 4					
Valve operator					
Equalizing valve no. 1					
Valve operator					
Equalizing valve no. 2					
Valve operator					
Vent blower					
Blower motor					
Motor operator					
Power leads (portable)					
Transformers					
Control panel					

Signature of Inspector

Table B-3. Coating Systems for Maintenance of Drydocking Facilities

Type of Surface and Exposure	Coating Designation and Minimum Dry Film Thickness (mils)					Total Minimum Dry Film Thickness (mils)
	Pretreatment Wash Primer	First Coat	Second Coat	Third Coat	Fourth Coat	
Exterior steel; immersed in or occasionally wetted with seawater	none	MIL-P-24441 Formula 150 (3)	MIL-P-24441 Formula 151 (3)	MIL-P-24441 Formula 154 (3)	none ^a	9
Exterior steel; always dry	MIL-P-15328 (0.3)	TT-P-645 or MIL-P-17545 (1)	TT-P-645 or MIL-P-17545 (1)	MIL-E-15130 (1-1/2)	MIL-E-15130 (1-1/2)	5
Interior steel other than caissons or chambers; occasionally flooded with seawater	MIL-P-15328 (0.3)	TT-P-645 (1)	MIL-E-17970 or MIL-E-17972 (1-1/2)	MIL-E-17970 or MIL-E-17972 (1-1/2)	none	4
Interior of steel caisson or chamber; occasionally flooded with seawater	none	MIL-C-18480 (14)	MIL-C-18480 (13)	MIL-C-18480 (13)	none	40
Decks and treads	MIL-P-15328 (0.3)	TT-P645 (1)	MIL-P-18210 (1-1/2)	MIL-P-18210 (1-1/2)	none	4
Piping	see Chapter 7					
Concrete and masonry	not painted					

^aTwo coats of MIL-P-15931 applied at 4 mils (total) dry film thickness may retard attachment and growth of fouling organisms for 2 or more years, if fouling is a problem.

INDEX

Accelerator admixtures, concrete	3.1.2.4
Admixtures (concrete), definition	3.1.2.4
Aggregate, definition	3.1.2.2
Air-entraining admixtures, concrete	3.1.2.4
Aluminum alloys, steel substitute	7.4.1.4
Armor units, reinforced concrete	1.4.2.9
.....	5.1.3
As-built drawings	1.6.2
Backing log, preservatives	2.1.4.8
<i>Bankia</i>	2.1.2.2
Barges	1.7.2
Barricades, safety	1.8.3
Beating piles	
Repair.....	2.3.2.1
.....	2.3.2.2
Replacement	2.3.1.1
Berthing	1.8.6
Biological corrosion.....	7.1.2
Bolt holes, preservatives	2.1.5
Braces	
Repair (flexible polyvinyl chloride sheet).....	2.3.2.3
Replacement	2.3.1.3
Breakwater	
Definition	1.4.2.9
Structural damage (rubble-mound).....	5.2.2.3
Brown rot, timber	2.1.2.1
Bulkheads (wood), replacement	2.3.1.10
Bullrails, preservatives.	2.1.4.8
Caisson, entrance	1.4.2.5.1
Cast-in-place concrete, repair method.....	3.4.3
Cathodic protection	
Definition	7.3.1
Galvanic anode system.....	7.3.2
Impressed current system	7.3.2
Catwalks, replacement.....	2.3.1.11
Cement	
Definition	3.1.2.1
Marine use.....	3.1.2.1
<i>Chelura</i>	2.1.2.2
Chocks	
Preservatives.....	2.1.4.9
Replacement	2.3.1.6
Coal tar epoxy, protective coating (steel).....	7.2.3
Coal tar, protective coating (steel).....	7.2.3
Coatings, concrete.....	3.4.9
Compressed air distribution system, inspection..	7.5.3.4.6
Compressive strength, concrete.....	3.1.3.2
Concrete	
Accelerated weathering.....	3.2.1.2
Barrier (pile repair).....	2.3.2.2.2
Chemical attack.....	3.2.1.3
Cracks.....	3.2.2.1
Curing	3.2.1.5
Curing temperature.....	3.1.4.3
Definition	3.1.1
Deterioration.....	3.2.1
Diamond-drilled cores.....	3.3.2
Dry-pack mortar repair.....	3.4.2
Durability	3.1.3.3
Fiber-reinforced	3.1.4.2
Finishing.....	3.2.1.5
High impedance voltmeter testing	3.3.3
Mechanical damage.....	3.2.1.8
Normal weathering.....	3.2.1.1
Plastic shrinkage	3.2.1.6
Prestressed	3.1.4.1
Protective coatings	3.4.9
Repair	3.4
Cast-in-place method	3.4.3
Epoxy resin method.....	3.4.8
Prepacked concrete method	3.4.5
Pumped method	3.4.7
Shotcrete method	3.4.4
Tremie method	3.4.6
Sonic testing.....	3.3.3
Spalls	3.2.2.2
Specialized.....	3.1.4
Strength.....	3.1.3.2

Concrete (continued)	
Structural settlement.....	3.2.1.7
Test hammer	3.3.2
Ultrasonic testing.....	3.3.3
Underwater.....	3.1.4.3
Volume change.....	3.2.1.4
Water/cement ratio	3.1.2.3
Watertightness	3.1.3.4
Workability	3.1.3.1
Copper alloys, steel substitute.....	7.4.1.3
Corrosion.....	1.5.3
Cathodic protection.....	7.3.1
Cell	7.1.1
Definition	7.1.1
Inhibitive pigments.....	7.2.1
Products, chemical analysis.....	7.5.2.6
Steel-reinforced concrete	3.2.1.4
Cracks, timber	2.1.6
Crane trackage	1.4.2.7
Creosote, preservative	2.1.3
Crustaceans	2.1.2.2
Curb, preservative.....	2.1.4.8
Currents.....	1.8.7
Decking	
Preservatives.....	2.1.4.10
Replacement	2.3.1.7
Degree-of-hazard	
Definition	1.4.1.1
Field measurements	1.6.1
Deterioration	
Causes.....	1.5.3
Concrete.....	3.2.1
Differential environmental corrosion	7.1.2
Divers	
Maintenance	1.7.1
Timber inspection	2.2.2
Dolosse (concrete armor units)	5.1.3
Dolphin	
Definition	1.4.2.3
Protection	1.8.5
Replacement	2.3.1.11
Dry abrasive blasting (steel).....	7.2.2
Drydock	
Inspection.....	7.5.3.6
Repair	7.6.6
Drypack mortar, concrete repair	3.4.2
Dry rot, timber.....	2.1.2.1
Electric power transmission/distribution system, inspection.....	7.5.3.4.7
Electrochemical oxidation	7.1.1
Epoxy adhesives.....	8.1.5
	8.2.6
Epoxy-polyamide, Protective coating (steel)	7.2.3
Epoxy putties	8.1.5
	8.2.6
Epoxy resin, concrete repair.....	3.4.8
Erosion	1.5.3
Erosion-corrosion	7.1.2
Excavations	1.7.5
Fender piles	
Repair	2.3.2.4
Replacement	2.3.1.9
Fenders, protection	1.8.5
Fiberglass construction	
Filament winding method.....	8.2.3
Lay-up method	8.2.1
Spray-up method.....	8.2.2
Fiberglass-reinforced plastic structures	8.1.1
Fiber-reinforced concrete	3.1.4.2
Fire curtain walls	
Preservatives.....	2.1.4.1
Replacement	2.3.1.8
Floating drydock, definition	1.4.2.5.2
Fleet mooring, definition.....	1.4.2.4
Floating steel pontoons, inspection	7.5.3.2
Floating steel structures	
Inspection.....	7.5.3.7
Repair	7.6.7
Foamed plastic structures.....	8.1.2
Foaming-in-place, urethane foam.....	8.2.4
Fungi	
Definition	2.1.2.1
Deterioration.....	1.5.3
Timber structures	2.1.1
Galvanic anode system. cathodic protection.....	7.3.2
Galvanic corrosion.....	7.1.2
Gas distribution system, inspection.....	7.5.3.4.5
Granite, graving docks.....	4.1.2
Graving dock, definition	1.4.2.5.1
Gribble	2.1.2.2
Groins	
Definition.....	1.4.2.10
Structural damage (rubble-mound)	5.2.2.2
Grouting	4.3.5
Hardware, timber structures.....	2.1.7
H-piling, repair.....	7.6.2.1
Hotwater distribution system, inspection	7.5.3.4.2

Index 2

Impressed current system, cathodic protection	7.3.2	Marine organisms	
Inspection		Control	1.4.1.4
Barges.....	1.7.2	Deterioration.....	1.5.3
Definition	1.4.1.1	Marine railway, definition	1.4.2.5.3
Divers.....	1.7.1	<i>Martesia striata</i>	2.1.2.2
Drydocks	7.5.3.6	Mechanical damage.....	1.5.3
Electronic (concrete).....	3.3.3	Microscopic testing, steel structures.....	7.5.2.5
Floating steel pontoon structures	7.5.3.2	Mold, timber structures	2.1.2.1
Floating steel structures.....	7.5.3.7	Mole, definition	1.4.2.7
Ladders	1.7.4	Mollusks	2.1.2.2
Mechanical (concrete).....	3.3.2	Mooring fittings	
Mooring fittings.....	7.5.3.5	Inspection.....	7.5.3.5
Protective coatings (steel).....	7.2.5	Repair	7.6.5
Rafts	1.7.2	Mound, definition	5.1.1
Rubble-mound structures.....	5.3.1	Nickel alloy, steel substitute	7.4.1.2
Scaffolds	1.7.3	Oil-borne preservatives	2.1.3
Soil-containing structures.....	6.3	Pentachlorophenol, preservatives.....	2.1.4.10
Steel pilings.....	7.5.3.1	Personnel, protection	1.8.2
Steel structures.....	7.5	Petrolatum coated tapes, protective coatings (steel)	7.2.3
Steel supporting components.....	7.5.3.3	Petroleum fuel distribution system, inspection	7.5.3.4.8
Stone masonry structures	4.2.1	Pholads	2.1.2.2
Timber structures.....	2.2	Piers	
Utility lines.....	7.5.3.4	Definition	1.4.2.1
Visual		Wrappings (PVC)	8.2.5
Concrete.....	3.3.1	Pile braces	
Steel.....	7.5.2.1	Freshwater preservative.....	2.1.4.6
Instructions, safety.....	1.8.1	Marine preservative	2.1.4.3
Intraservice functions.....	1.1.3.1	Pile caps	
Jetties		Freshwater preservative.....	2.1.4.5
Definition	1.4.2.8	Marine preservative	2.1.4.3
Structural damage (rubble-mound)	5.2.2.4	Replacement	2.3.1.2
Joint service responsibility	1.1.2	Piles, preservatives.....	2.1.4.1
Ladders	1.7.4	Pile repair	
Life belts, safety.....	1.8.2	Concrete barrier.....	2.3.2.2.2
<i>Limnoria</i>	2.1.2.2	Flexible PVC.....	2.3.2.2.1
Maintenance		Section replacement	2.3.2.2.3
As-built drawings	1.6.2	Pile top caps	
Definition	1.4.2.1	Freshwater preservative.....	2.1.4.4
Divers.....	1.7.1	Marine preservative	2.1.4.2
Economics.....	1.5.2	Pipe piling (steel), repair	7.6.2.3
Engineering	1.3.2	Planning	5
Policy	1.3.2	Plastics, steel substitutes	7.4.2
Sketches.....	1.6.3	Plastic wraps	8.1.4
Program	1.5.1	Polystyrene foam structures.....	8.1.2
Marine borers		Polyurethane foam (flexible), pile repair	2.3.2.2.1
Definition	2.1.2.2		
Timber structures.....	2.1.2		

Poly(vinyl chloride) sheets		Riprap, definition.....	5.1.3
Brace repair.....	2.3.2.3	Roads, paved	1.4.2.7
Pile wrappings	2.1.4.3	Rubber fenders	8.1.3
Potential measurements, cathodic		Rubber, steel substitute	7.4.3
protection systems.....	7.5.2.7	Rubble, definition	5.1.2
Prepacked concrete, concrete repair	3.4.5	Rubble-mound structures.....	5.1
Preservatives		As-built drawings	5.4.1
Creosote.....	2.1.3	Breakwater	1.4.2.9
Creosote solutions.....	2.1.3	Deterioration.....	5.2.1
Oil-borne	2.1.3	Drainage.....	5.3.2
Pentachlorophenol.....	2.1.4.10	Inspection.....	5.3.1
Water-borne	2.1.3	Repair/replacement	5.4.2
Pressure treatment	2.1.4	Seawall	1.4.2.11
Pressure treatments, preservatives	2.1.4	Structural damage	
Prestressed concrete	3.1.4.1	Breakwater	5.2.2.3
Programming.....	1.5.1	Groin.....	5.2.2.2
Protective coatings		Jetty	5.2.2.4
Concrete.....	3.4.9	Seawall	5.2.2.1
Film thickness	7.2.5	Rust inhibitor, steel coatings	7.2.2
Steel		Sacrificial anodes	7.3.2
Application	7.2.4	Safety belts.....	1.8.2
Inspection.....	7.2.5	Safety, instructions	1.8.1
Surface preparation	7.2.2	Salt treatments, timber.....	2.1.4.10
Types	7.2.3	Sap stain fungi, timber	2.1.2.1
Pumped concrete, concrete repair	3.4.7	Scaffolds	
Quaywall, definition.....	1.4.2.6	Hung	1.7.3.3
Radiography testing, steel structures.....	7.5.2.4	Pipe.....	1.7.3.2
Rafts	1.7.2	Wood	1.7.3.1
Railroads	1.4.2.7	Seasoning checks, timber	2.1.6
Repair		Seawalls	
Definition	1.4.1.3	Definition.....	1.4.2.11
Drydocks	7.6.6	Structural damage (rubble-mound)	5.2.2.1
Excavations.....	1.7.5	Sewage collection system, inspection	7.5.3.4.4
Floating steel structures.....	1.7.6.7	Sheeting (wood), replacement.....	2.3.1.10
H-piling.....	7.6.2.1	Sheet piling (steel), repair	7.6.2.2
Mooring fittings.....	7.6.5	Shipworm	2.1.2.2
Steel piling.....	7.6.2	Shotcrete, concrete repair	3.4.4
Steel pipe piling	7.6.2.3	Shrinkage cracks, stone masonry structures	4.3.3
Steel sheet piling	7.6.2.2	Soft rot fungi, timber structures.....	2.1.2.1
Steel supporting components.....	7.6.3	Soil	
Stone masonry		Classification	6.1.3
Grouting.....	4.3.5	Compaction control	6.2.2
Tuck-pointing.....	4.3.4	Compaction methods.....	6.2.3
Utility lines.....	7.6.4	Soil-containing structures	
Responsibility		Definition	6.1.1
Air Force.....	1.2.3	Dewatering	6.4.3
Army	1.2.1	Erosion.....	6.4.1
Joint service	1.2	Grouting	6.4.4
Navy.....	1.2.2	Inspection.....	6.3

Index-4

Soil-containing structures (continued)	
Repair	6.4
Sealing	6.4.2
Soil placement	6.2.1
Spacer blocks, preservatives	2.1.4.7
Spalls, concrete	3.2.2.2
<i>Sphaeroma</i>	2.1.2.2
Stainless steels, steel substitute	7.4.1.5
Standards, development	1.3.1
Steam distribution/condensate return	
system, inspection	7.5.3.4.1
Steel structural substitutes	7.4
Steel structures	
Cathodic protection	7.3.1
Corrosion	7.1
Corrosion products	7.5.2.6
Metal thickness	7.5.2.2
Microscopic testing	7.5.2.5
Potential measurements	7.5.2.7
Protective coatings	7.2.1
Radiography testing	7.5.2.4
Repair	7.6.1
Surface preparation for coatings	7.2.2
Ultrasonic testing	7.5.2.3
Visual inspections	7.5.2.1
Steel supporting components	
Inspection	7.5.3.3
Repair	7.6.3
Steel surface preparation	
Dry abrasive blasting	7.2.2
Wet abrasive blasting	7.2.2
Steel H-piling, repair	7.6.2.1
Steel piling	
Inspection	7.5.3.1
Repair	7.6.2
Steel pipe piling, repair	7.6.2.3
Steel sheet piling, repair	7.6.2.2
Stone masonry structures	4.1.1
Engineering investigation	4.3.1
Grouting	4.3.5
Inspection	4.2.1
Documentation	4.2.3
Settlement	4.2.2
Shrinkage cracks	4.3.3
Tuck-pointed joints	4.3.4
Weep holes	4.3.2
Stray current corrosion	7.1.2
Stringers	
Preservatives	2.1.4.6
Replacement	2.3.1.4
String pieces	
Preservatives	2.1.4.8
Replacement	2.3.1.5
Syntactic foam structures	8.1.2
Telephone wire systems, inspection	7.5.3.4.9
Teredines	2.1.2.2
<i>Teredo</i>	2.1.2.2
Termites	
Deterioration	1.5.3
Timber structures	2.1.2
Tetrapods (concrete armor units)	5.1.3
Tides	1.8.8
Timber structures	
Exposed area inspection	2.2.1
Submerged area inspection	2.2.2
Timber (treated), handling	2.1.5
Titanium alloys, steel substitute	7.4.1.1
Traffic control	1.8.4
Tremie concrete, concrete repair	3.4.6
Tribars (concrete armor units)	5.1.3
Tuck-pointing, stone masonry repair	4.3.4
Ultrasonic testing	
Timber structures	2.2.2
Steel structures	7.5.2.3
Underwater concrete	3:1.4.3
Urethane (foamed-in-place)	8.1.2
Utility lines	
Inspection	7.5.3.4
Repair	7.6.4
Vertical lift, definition	1.4.2.5.4
Vibratory compaction, soil	6.2.3
Vinyl resin paint, protective coating (steel)	7.2.3
Water-borne preservatives	2.1.3
Water, concrete component	3.1.2.3
Water distribution system, inspection	7.5.3.4.3
Waterfront structures	
As-built drawings	1.6.2
Breakwater	1.4.2.9
Corrosion	1.5.3
Deterioration	1.5.3
Dolphin	1.4.2.3
Fleet mooring	1.4.2.4
Floating drydock	1.4.2.5.2
Graving dock	1.4.2.5.1

Waterfront structures (continued)

Groin	1.4.2.10
Inspection	1. 5.4
Jetty	1.4.2.8
Marine railway	1.4.2.5.3
Mole	1.4.2.7
Pier	1.4.2.1
Quaywall	1.4.2.6
Replacement cost	1.5.2
Seawall.....	1.4.2.11

Sketches	1.6.3
Stability	1.6.4
Vertical lift	1.4.2.5.4
Wharf	1.4.2.2
Water-reducing admixtures, concrete	3.1.2.4
Weep holes, stone masonry structures.....	4.3.2
Wet abrasive blasting (steel).....	7.2.2
Wharf, definition	1.4.2.2
White rot, timber.....	2.1.2.1
Zinc inorganic, protective coatings (steel).....	7.2.3

Index-6

PIN: 005245-000