

FEAP-TR 96/73
July 1996

Standard HVAC Control Systems: Operation and Maintenance for Maintenance Mechanics

by
David M. Schwenk and Glen A. Chamberlin
U.S. Army Construction Engineering Research Laboratories
Champaign, IL 61826-9005

Approved for Public Release; Distribution is Unlimited.

19970331 025

DTIC QUALITY INSPECTED 3

The contents of this report are not to be used for advertising, publication, or promotional purposes. Citation of trade names does not constitute an official endorsement or approval of the use of such commercial products. The findings of this report are not to be construed as an official Department of the Army position, unless so designated by other authorized documents.

DESTROY THIS REPORT WHEN IT IS NO LONGER NEEDED

DO NOT RETURN IT TO THE ORIGINATOR

| REPORT DOCUMENTATION PAGE | | | Form Approved OMB No. 0704-0188 | |
|--|---|--|---|--|
| Public reporting burden for this collection of information is estimated to average 1 hour per response, including the time for reviewing instructions, searching existing data sources, gathering and maintaining the data needed, and completing and reviewing the collection of information. Send comments regarding this burden estimate or any other aspect of this collection of information, including suggestions for reducing this burden, to Washington Headquarters Services, Directorate for Information Operations and Reports, 1215 Jefferson Davis Highway, Suite 1204, Arlington, VA 22202-4302, and to the Office of Management and Budget, Paperwork Reduction Project (0704-0188), Washington, DC 20503. | | | | |
| 1. AGENCY USE ONLY (Leave Blank) | 2. REPORT DATE July 1996 | 3. REPORT TYPE AND DATES COVERED Final | | |
| 4. TITLE AND SUBTITLE Standard HVAC Control Systems | | | 5. FUNDING NUMBERS FEAP FE-FQ4 | |
| 6. AUTHOR(S) David M. Schwenk and Glen A. Chamberlin | | | SERDP EN-639 | |
| 7. PERFORMING ORGANIZATION NAME(S) AND ADDRESS(ES) U.S. Army Construction Engineering Research Laboratories (USACERL) P.O. Box 9005 Champaign, IL 61826-9005 | | | 8. PERFORMING ORGANIZATION REPORT NUMBER TR 96/73 | |
| 9. SPONSORING / MONITORING AGENCY NAME(S) AND ADDRESS(ES) U.S. Army Center for Public Works ATTN: CECPW-EM 7701 Telegraph Road Alexandria, VA 22310-3862 | | | 10. SPONSORING / MONITORING AGENCY REPORT NUMBER | |
| 11. SUPPLEMENTARY NOTES Copies are available from the National Technical Information Service, 5285 Port Royal Road, Springfield, VA 22161. | | | | |
| 12a. DISTRIBUTION / AVAILABILITY STATEMENT Approved for public release; distribution is unlimited. | | | 12b. DISTRIBUTION CODE | |
| 13. ABSTRACT (Maximum 200 words) The U.S. Army Corps of Engineers has published documents that describe and define design requirements and specifications for Corps-standard heating, ventilating, and air-conditioning (HVAC) control systems and hardware. However, those documents are too large and complex to be field-usable for operations and maintenance (O&M) training and reference purposes. In-lab investigations by the U.S. Army Construction Engineering Research Laboratories (USACERL) and extensive field experience with Corps-standard HVAC control systems (including control panels and equipment) have provided the authors the basis for identifying operation and maintenance procedures directly applicable to O&M personnel in the field. Information from previously published HVAC control systems technical documentation has been combined into this one-volume reference designed specifically for training and field use by Army HVAC O&M personnel. | | | | |
| 14. SUBJECT TERMS HVAC Systems operation and maintenance military installations | | | 15. NUMBER OF PAGES 174 | |
| | | | 16. PRICE CODE | |
| 17. SECURITY CLASSIFICATION OF REPORT Unclassified | 18. SECURITY CLASSIFICATION OF THIS PAGE Unclassified | 19. SECURITY CLASSIFICATION OF ABSTRACT Unclassified | 20. LIMITATION OF ABSTRACT SAR | |

Foreword

This study was conducted for the U.S. Army Center for Public Works under the Facilities Engineering Applications Program (FEAP) Work Unit FE-FQ4, "Retrofit Single-Loop Digital Controls," and Strategic Environmental Research and Development Program (SERDP) project number EN-639, "Low-Energy Model Installation Program." The technical monitors were Phil Conner, CECPW-EM, and Dr. John Harrison, SERDP.

The work was performed by the Engineering Division (FL-E) of the Facilities Technology Laboratory (FL), U.S. Army Construction Engineering Research Laboratories (USACERL). The USACERL principal investigator was David M. Schwenk. Alan Chalifoux, Richard Strohl, and Alfonso Guativa are credited for their support and assistance in field testing this document. This document incorporates the collective experiences and technical contributions of many individuals who were involved in the development of the HVAC control panel technology. Most recently and directly these include Dale Herron, Jim Miller, and Victor Storm, all of whom were members of the in-house development team. Special recognition is due to Victor Storm, Richard Strohl, Jim Miller, and Scott Gobin (CESASEN) for their dedication and long hours spent in various mechanical rooms. Larry M. Windingland is Acting Chief, CECER-FL-E, and Donald F. Fournier is Acting Operations Chief, CECER-FL. The USACERL technical editor was Agnes E. Dillon, Technical Resources.

COL James T. Scott is Commander of USACERL and Dr. Michael J. O'Connor is Director.

Contents

| | |
|--|-----------|
| SF 298 | 1 |
| Foreword | 2 |
| List of Figures and Tables | 5 |
| 1 Introduction | 9 |
| Background | 9 |
| Objective | 10 |
| Approach | 10 |
| Scope | 10 |
| Mode of Technology Transfer | 10 |
| Metric Conversion Factors | 11 |
| 2 Training and Technical Assistance | 12 |
| 3 Introduction to HVAC Control Theory | 14 |
| General | 14 |
| Simple Control Loops | 14 |
| Open Loop Control | 15 |
| Closed Loop Control | 16 |
| Block Diagrams | 17 |
| Controllers | 18 |
| Control Modes | 19 |
| 4 Standard HVAC Control Systems and Loops | 36 |
| Standard HVAC Control Systems | 36 |
| Standard Control Loops | 36 |
| 5 Operation and Maintenance Documentation | 53 |
| 6 Operation | 54 |
| Standard Control Panel | 54 |
| Posted Instructions | 54 |

| | | |
|----------|---|-----|
| 7 | Maintenance | 77 |
| | Tools and Spare Parts | 77 |
| | Control Hardware | 78 |
| 8 | Preventive/Recurring Maintenance and Safety | 117 |
| | Maintenance | 117 |
| | Safety | 117 |
| 9 | Summary | 118 |
| | References | 119 |
| | Cited | 119 |
| | Uncited | 119 |
| | Abbreviations and Acronyms | 121 |
| | Appendix A: Standard Control Symbols | 123 |
| | Appendix B: Controller V/mA Conversion to Temperature Tables | 141 |
| | Appendix C: Transmitter mA Output Versus Process Variable Input Tables | 147 |
| | Appendix D: Standard Resistance Values for 100 ohm Platinum RTD Tables | 165 |
| | Distribution | |

List of Figures and Tables

Figures

| | | |
|----|---|----|
| 1 | Simple control loop | 14 |
| 2 | Open loop control | 16 |
| 3 | Closed loop control | 17 |
| 4 | Block diagram of control loop | 18 |
| 5 | On-off control | 20 |
| 6 | Example of multiposition control | 20 |
| 7 | Floating control | 21 |
| 8 | Proportional control | 23 |
| 9 | Manual reset, direct- and reverse-acting control modes | 27 |
| 10 | Examples of wide versus narrow proportional band | 29 |
| 11 | Definition of integral mode constant | 31 |
| 12 | Proportional-integral control | 33 |
| 13 | Proportional-integral-derivative control | 35 |
| 14 | Control device symbols | 37 |
| 15 | Unique identifier naming convention | 37 |
| 16 | Symbol for an HVAC equipment element | 37 |
| 17 | Preheat coil temperature control loop | 38 |
| 18 | Typical heating coil discharge air temperature reset schedule | 39 |

| | | |
|----|--|----|
| 19 | Heating coil loop with outside air reset | 40 |
| 20 | Example reset schedule | 41 |
| 21 | Cooling coil temperature control loop | 44 |
| 22 | Economizer/mixed air temperature control loop | 45 |
| 23 | Supply duct static pressure control loop | 48 |
| 24 | Return fan volume control loop | 49 |
| 25 | Humidity control loop | 52 |
| 26 | Typical standard control schematic | 56 |
| 27 | Typical sequencing schedule | 58 |
| 28 | Typical equipment schedule | 59 |
| 29 | Control system ladder diagram | 61 |
| 30 | Control system fan starter circuit ladder diagram | 61 |
| 31 | Standard control panel inner door—front and back views | 66 |
| 32 | Standard control panel—back-panel layout | 68 |
| 33 | Standard control panel—side view | 70 |
| 34 | Standard terminal block layout | 71 |
| 35 | Standard wiring diagram for SLDC | 72 |
| 36 | Standard wiring diagram for SLDC economizer | 72 |
| 37 | Supply fan wiring diagram | 73 |
| 38 | Return fan wiring diagram | 73 |
| 39 | Exhaust fan wiring circuit | 74 |
| 40 | Pump wiring circuit | 74 |

| | | |
|----|---|-----|
| 41 | Control panel power wiring diagram | 75 |
| 42 | Front view of a typical single-loop controller | 78 |
| 43 | Typical temperature transmitter applications | 87 |
| 44 | Temperature transmitter output versus sensed temperature input | 88 |
| 45 | Balanced RTD bridge circuit | 90 |
| 46 | Calibration set-up for temperature circuit | 94 |
| 47 | RTD simulator | 95 |
| 48 | Standard symbol for duct differential pressure sensor and transmitter, and for linear input/output relationship. | 97 |
| 49 | Standard symbol for space or duct relative humidity sensor and transmitter and linear input/output relationship | 99 |
| 50 | Standard symbol for an airflow measurement array and transmitter | 101 |
| 51 | Typical pitot tube airflow measurement station | 101 |
| 52 | Positive positioner schematic | 103 |
| 53 | Positive positioner (PP) applied to a damper, and the standard symbol for a PP | 104 |
| 54 | Double-pole, double-throw (DPDT) relay | 107 |
| 55 | Typical control loop wiring | 110 |
| 56 | Transmitter range of operation | 111 |
| 57 | Typical loop driver applications | 114 |
| 58 | Transmitter loop output load resistance | 116 |
| 59 | Controller output loop load resistance | 116 |

Tables

| | | |
|---|---|----|
| 1 | Integral mode constant unit equivalencies | 32 |
| 2 | Return fan controller ratio and bias example | 51 |
| 3 | Example of SLDC ratio functions | 82 |
| 4 | Example of SLDC ratio and bias function | 82 |
| 5 | Example of SLDC deviation contact function | 84 |
| 6 | Controller problem diagnosis and troubleshooting | 85 |
| 7 | Transmitter problem diagnosis and troubleshooting | 91 |
| 8 | Transmitter problem diagnosis and troubleshooting—incorrect output | 92 |

1 Introduction

Background

In 1990 the U.S. Army Corps of Engineers published a heating, ventilating, and air-conditioning (HVAC) control systems guide specification (CEGS-15950), and in 1991 a HVAC control systems technical manual (TM 5-815-3) was issued. These documents describe and provide definitive requirements for Corps HVAC control systems and hardware. The technical requirements spelled out in CEGS-15950 and TM 5-815-3 are based on needs identified by extensive field experience and follow-up research. Many of the fundamental requirements are based on the text of the Air Force Engineering Technical Letter (ETL) 83-1, which identifies serious operation and maintenance (O&M) deficiencies that have been experienced with HVAC control systems. This document is a continuation of the Corps efforts to improve HVAC control system O&M.

CEGS-15950 requires the contractor who installs the HVAC control system to provide O&M manuals with each HVAC control system. Out of necessity, to minimize costs, the CEGS-15950 requirements for the contractor-supplied O&M manuals are minimal. This report focuses on O&M activities and details and is intended to complement the contractor-provided O&M manuals.

At the discretion of the contractor, he/she may choose to use portions of this document as part of the contractor-provided training. CEGS-15950 defines the requirements of this training. The contractor-provided training requirements also are described in Chapter 2.

The definitive, standard requirements of CEGS-15950 and TM 5-815-3 make it possible to use this document as a tool in operating and maintaining the Corps standard control systems, regardless of the control system contractor and hardware supplier.

Objective

The objective of this report is to provide a field-usable training and reference manual for HVAC O&M personnel.

Approach

This report is based on in-lab investigations and extensive field experience with the Corps standard HVAC control systems at Fort Hood, Texas, and other installations. Most of the information in this report was obtained while performing system retrofits and assisting other Corps personnel in performing system retrofits. Some of the material is excerpts from CEGS-15950 and TM 5-815-3 and Corps of Engineers Proponent Sponsored Engineer Corps Training (PROSPECT) courses "HVAC Control Systems Design" (Course 340) and "HVAC Control System Quality Verification" (Course 382).

Scope

CEGS-15950 and TM 5-815-3 provide the technical requirements for O&M procedures.

Mode of Technology Transfer

The experiences and information obtained during the development of this report have impacted CEGS-15950 and TM 5-815-3. Technical modifications and clarifications have been incorporated into CEGS-15950 and TM 5-815-3. In addition, a number of modifications and enhancements have been made to PROSPECT courses 340 and 382. Most importantly, a future PROSPECT course intended for O&M staff is in the planning stages as a result of this work. An instructional videotape also is being considered.

Metric Conversion Factors

U.S. standard units of measure are used throughout this report. A table of metric conversion factors is presented below.

| | | |
|---------|---|----------------------|
| 1 in. | = | 25.4 mm |
| 1 ft | = | 0.305 m |
| 1 sq ft | = | 0.093 m ² |
| 1 cu ft | = | 0.028 m ³ |
| 1 mi | = | 1.61 km |
| 1 lb | = | 0.453 kg |
| 1 gal | = | 3.78 L |
| 1 psi | = | 6.89 kPa |
| 1 μm | = | 1x10 ⁻⁶ m |
| °F | = | (°C × 1.8) +32 |

2 Training and Technical Assistance

Contractors who install standard HVAC control systems are required, in accordance with CEGS-15950, to provide local O&M training for the systems they install. Some mechanics, however, may require training beyond what the contractor is obligated to provide (such as fundamental control theory and principles, for example).

The contractor-provided training course is required to be conducted at the project site for operating staff members designated by the contracting officer. Prior to training, the contractor is required to submit an outline for the course, with a proposed time schedule. The training period should be for a total of 32 hours (or an otherwise specified time period) and is to be conducted within 30 days after successful completion of the system performance verification test.

One training manual is to be furnished for each trainee; two additional copies are to be placed in archival storage at the project site. The manuals are to include the agenda, the defined objectives for each lesson, and a detailed description of the subject matter for each lesson. Two copies of audiovisual materials shall be delivered for archival storage at the project site, either as a part of the printed training manuals or on the same media as that used during the training session.

The training course is required to cover all of the material contained in the contractor supplied O&M manual, the layout and location of each HVAC control panel, the layout of one of each type of unitary equipment and the locations of each, the location of each system-control device external to the panels, the location of the compressed-air station, preventive maintenance, troubleshooting, diagnostics, calibration, adjustment, commissioning, tuning, and repair procedures. Typical systems and similar systems may be treated as a group, with instruction on the physical layout of one such system. The results of the Performance Verification Test (PVT) and the calibration, adjustment, and commissioning report shall be presented as benchmarks of HVAC control-system performance by which to measure future system operational effectiveness.

Another potential source of control system training is from those who have attended one or both of the HVAC control system PROSPECT courses (Course 340 and Course

382). Individuals who attend these courses receive 1 week of intensive instruction on the standard HVAC control systems.

Motivated individuals may choose to pursue some form of self-study. Some controls vendors have video tapes; although these tapes are not specific to the Corps standard controls, they are useful in providing fundamental instruction on HVAC controls. A number of publications are available that provide fundamental instruction on HVAC controls (see References). Much also can be learned from studying contractor submittals and vendor data. Specification sheets, operation manuals, and installation manuals contain a wealth of information.

A more rigorous, but rewarding, approach to HVAC control system training is formal courses. A course in basic electricity and electronics will help to provide an in-depth understanding of the electrical and electronic interfaces in the standard control panel and devices. Several sources, including at least the University of Wisconsin and ASHRAE, provide short courses (up to 1 week in duration) in HVAC systems and controls.

Technical assistance in field support of HVAC controls is available from the Center for Public Works (CPW) and Savannah District—the Technical Center of Expertise (TCX) for HVAC Controls.* Local sources of assistance include the contractor who installed the control system, or assistance may be sought from those who have attended one or both of the HVAC Control System PROSPECT courses. In addition to receiving intensive instruction on the standard HVAC control systems, individuals who attended these courses received hands-on instruction. Locally, individuals from your field area office may have attended the quality verification course (Course 382).

* U.S. Army Engineering District, Savannah, P.O. Box 889, Savannah, GA 31402-0889; tel. 912-652-5386.

Controlled processes usually have a setpoint, which is the desired value of the process variable. In the kerosene stove example, the room temperature is the process variable which one desires to control. Other process variables commonly controlled by HVAC systems, in addition to temperature, are pressure, flow, and humidity. Various disturbances such as changes in setpoint, supply, demand, and/or environment may cause a process variable to deviate from its setpoint. To counteract the effects of these disturbances, the system must measure any changes in the process variable caused by the disturbances. This is the job of the sensor. Sensors are devices used within HVAC systems to measure process variables. In the kerosene stove example, the input, or disturbance, is an undesirable temperature, and the sensor is the person in the room who receives the input.

A controller receives the process variable signal from a sensor, compares it to the setpoint, and provides an output to counteract the effects of any disturbances. In many instances, the sensor may be a part of the controller, as in the kerosene stove example. When a controller is informed of a disturbance, its output signal directs a controlled device to take corrective action. In other words, a controller changes its output as required by changes in its input to maintain a process variable at its setpoint.

A controlled device reacts to signals received from a controller to correct the value of a process variable. A controlled device may be a valve, damper, electric relay, or a motor driving a pump or a fan. In the kerosene stove example, the stove is the controlled device.

Open Loop Control

When a control loop senses a process variable, makes a control decision, and sends an output signal to a control device without input information related to the results of its control action, the control loop is said to be an open loop. An open loop control system does not have a direct link between the value of the process variable and the controller. In other words, it provides no feedback to the controller of results of its control actions. If, in our example, the stove had a fixed cycle of on and off times regardless of the temperature in the room, this would be an open loop control system. The stove would continue its fixed pattern of on/off cycling in spite of the temperature in the room because of this lack of feedback of results to the controller.

Figure 2 illustrates an open control loop in which the heat supplied by a radiator depends on the outside air temperature. The outdoor air temperature transmitter measures the outside temperature and provides this input to the temperature controller. The controller makes a decision to increase the heat flow to the space

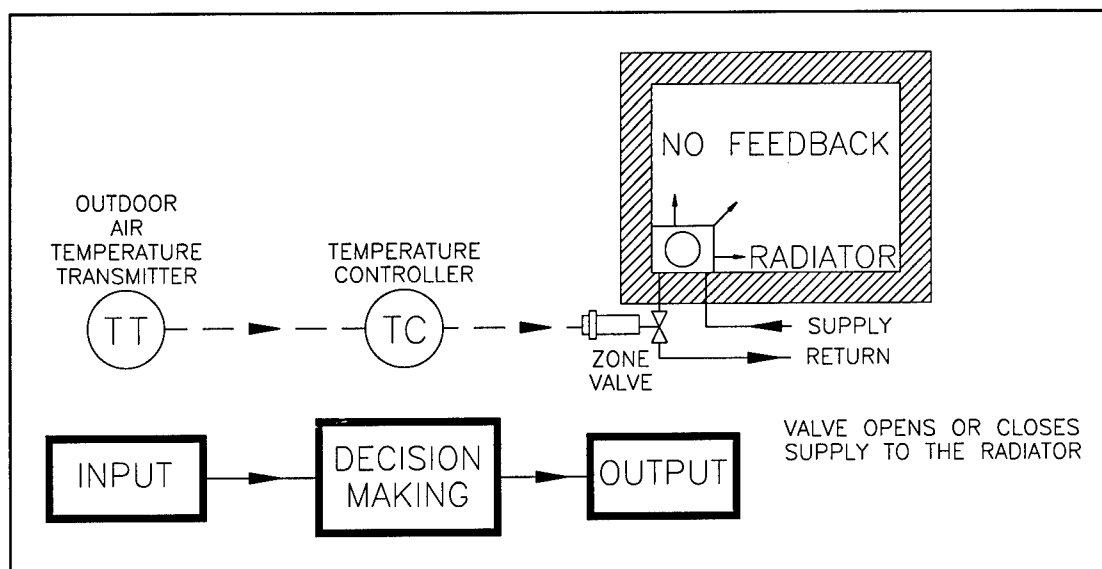

Figure 2. Open loop control.

when the outdoor temperature decreases, and vice versa. The controller then sends an output signal to open or close the valve accordingly.

Open loop control systems are uncommon in HVAC applications but may be used for time-dependent operations such as starting and stopping of fans. Also, they may be used to adjust the setpoint of a controller based on an independent variable such as outdoor air temperature. More common to HVAC applications are closed loop control systems.

Closed Loop Control

When a controller changes its output decision based on updated input information, it is said to be operating in a closed loop. Most of the control loops in HVAC systems are closed loops. Using the kerosene stove example, closed loop control might be more appropriate. After the person in the room turns on the stove, the room begins to warm up and keeps getting warmer until it is uncomfortable, and the person turns the heat down. If it gets too cold again, the person turns the heat back up. This process would continue as the person attempts to maintain a comfortable temperature, or setpoint.

In closed loop control, feedback is provided to a controller. The controller is informed of changes in the process variable, and it changes its output based on updated input information. Under actual operating conditions, outside forces constantly act on the various parts of a system to upset the balance. This sets the loop cycle in operation to reestablish balance. A closed loop system is one in which

all parts have an effect on the next step in the loop and are affected by the action of the previous step. In other words, a closed loop control system is an error-sensitive, self-correcting system.

Figure 3 illustrates a closed loop control. Air enters the duct and is heated by the heating coil (H/C). The air temperature (process variable) is measured by a temperature-sensing element, and this value is sent by the temperature transmitter to the temperature controller. The controller compares it to the setpoint and, based on the difference between the process variable and the setpoint, sends a signal to the valve to increase or decrease the flow through the coil valve which, in turn, increases or decreases the air temperature. The new air temperature is measured by the temperature-sensing element, and this process continues as the system attempts to control the temperature at or near the setpoint.

Open loops and closed loops may be used in combination in some HVAC control system applications. Several closed loops also may be used in combination.

Block Diagrams

A control loop may be represented in the form of a block diagram. Figure 4 shows a setpoint being compared to the feedback signal from a process variable. This difference is fed into a controller, which sends a control signal to a controlled device.

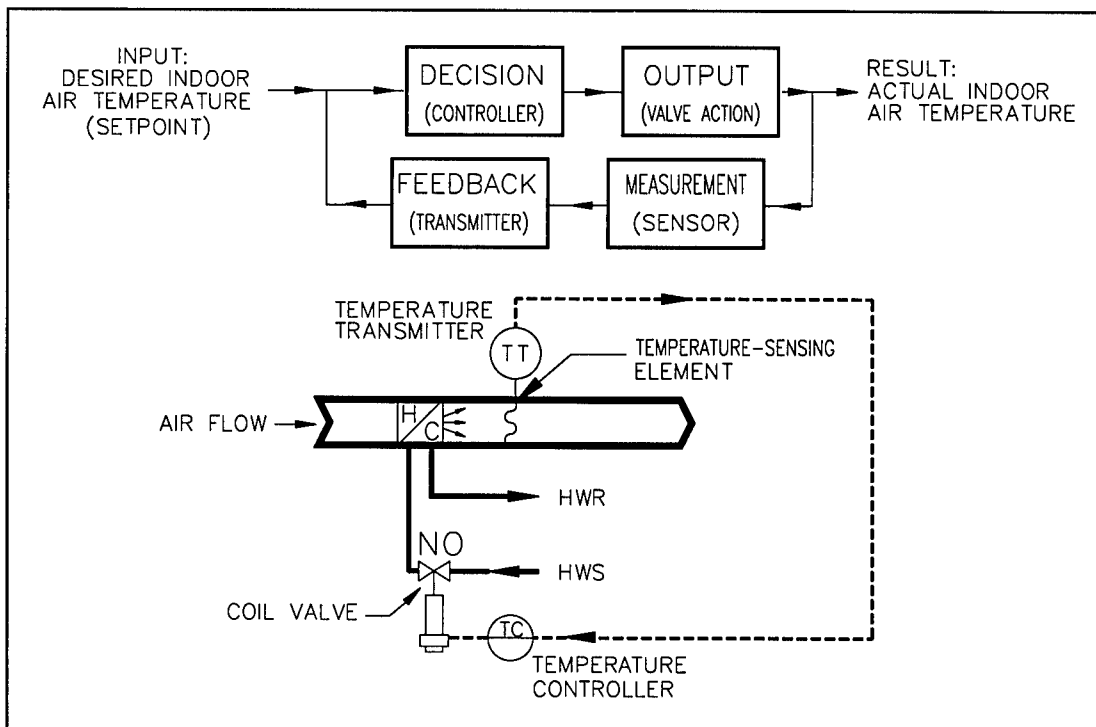

Figure 3. Closed loop control.

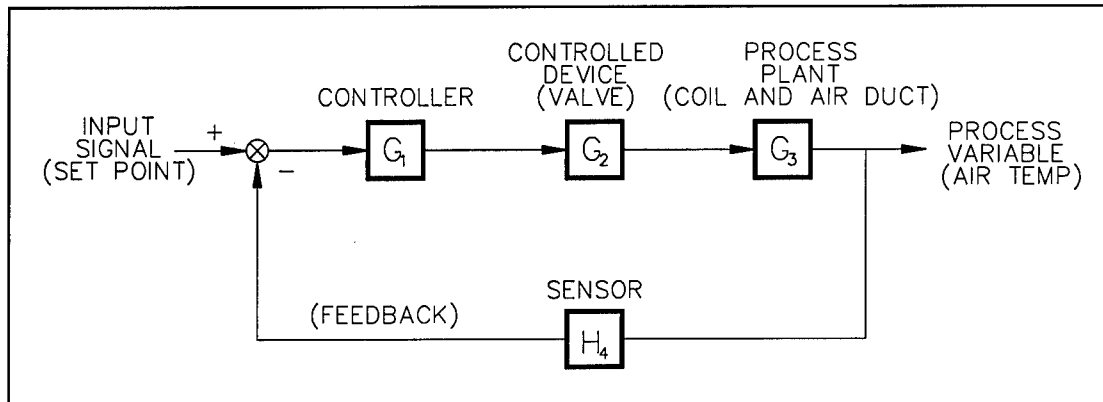

Figure 4. Block diagram of control loop.

In this instance, the controlled device might be a valve that controls the amount of steam flow through a coil. The amount of steam flow would be the input to the next block, which represents a process plant. From the process plant block would come a process variable, which would be a temperature. The process variable would be sensed by the sensing element and fed to the controller as feedback, completing the loop.

Each component of Figure 4 can be represented by a transfer function, which is an idealized mathematical representation of the relationship between the input and output variables of the component. Ideally, a transfer function can be sufficiently detailed to describe both the dynamic and steady-state characteristics of a device. The dynamics of a component can be represented in the time domain by a differential equation.

The gain of a transfer function is the amount by which the output of the component will change for a given change of input under steady-state conditions (gain = output/input). If an element is linear, its gain remains constant. However, many control system components are nonlinear and have varying gains, depending on the operating conditions.

Controllers

Traditionally, HVAC control has been performed by analog devices. A common analog HVAC device is a pneumatic receiver/controller. The principle behind pneumatic controllers is that a sensor sends to a controller a pneumatic signal with pressure proportional to the value of a measured process variable. The controller compares this pneumatic signal from the sensor to the desired value of air pressure and outputs a control signal based on this comparison. The pneumatic receiver/controller receives and acts on data continuously.

Recently, digital controllers have entered the HVAC control arena. A digital controller receives an electric analog signal from a sensor, converts it to a number, then internally performs mathematical operations on this number. The result of the mathematical operation is used to position a controlled device. Typically, before the output is sent to the controlled device, it is converted to an analog electronic signal. A digital controller samples (reads) the input data signal then performs its calculations prior to sending the output signal to the controlled device. If the sampling interval (time lapse between readings) for the digital controller is short, no degradation in control performance will be seen due to the sampling, and the controller acts much the same as a continuous controller.

Control Modes

The mode of control is the manner by which a control system makes corrections in response to a disturbance; it generally is a function of the particular controller. The proper matching of the control mode to the process determines the overall performance of the control system. To satisfy the need for various kinds of control response, several types of control modes may be used and include on-off action, multi-position, floating, and modulating control modes.

On-Off Action

On-off (or two-position) control provides only two positions: either full-on or full-off. There are no intermediate positions. When the process variable deviates a predetermined amount from the setpoint, the controller directs the controlled device to move to either of its extreme positions. This mode of control is the simplest available; however, this mode has disadvantages. On-off control may allow the process variable to vary over a wide range instead of maintaining a nearly steady condition. If this range becomes too narrow, the controlled device will wear itself out by continually switching on and off. An example of two-position control is a unit heater control in which a thermostat turns on a heater when the space temperature drops to 65 °F and turns it off when the space temperature rises to 67 °F. The thermostat is said to have a differential of 2 °F and a setpoint of 65 °F. This example is illustrated in Figure 5.

Figure 5 illustrates the action of an on-off controller in response to a process variable as it drifts above and below the control differential. In Figure 5, the on-off control mode often results in a slight undershoot below the lower end of the differential and a slight overshoot above the upper end of the differential. As the temperature in the room drops, the space temperature thermostat signals the heater to turn

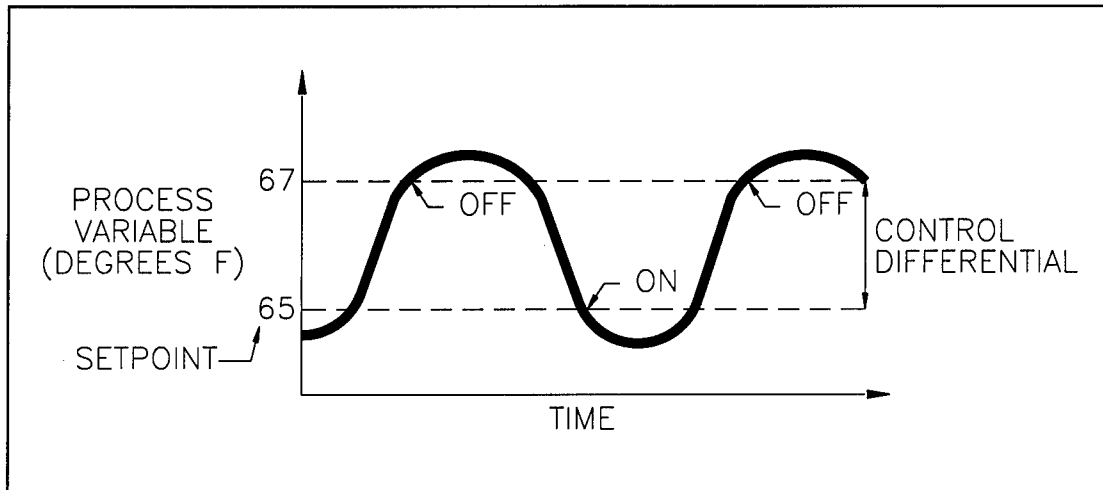

Figure 5. On-off control.

on. There is a time lapse before the heater actually begins to raise the space temperature. Meanwhile, the space temperature drops further, causing an undershoot below the lower end of the differential. Similarly, as the heater raises the space temperature to the shutoff point, the on-off controller will shut off the heater. After the heater shuts off, it may continue radiating heat to the room, causing a slight overshoot on the high end of the differential.

Multiposition Control

Multiposition control, as illustrated in Figure 6, is an extension of on-off control to two or more stages. When the range between full-on to full-off is too wide to achieve the operation desired, multiple stages with smaller ranges can be used. Each stage has only two positions (on or off), but the system has as many positions as there are

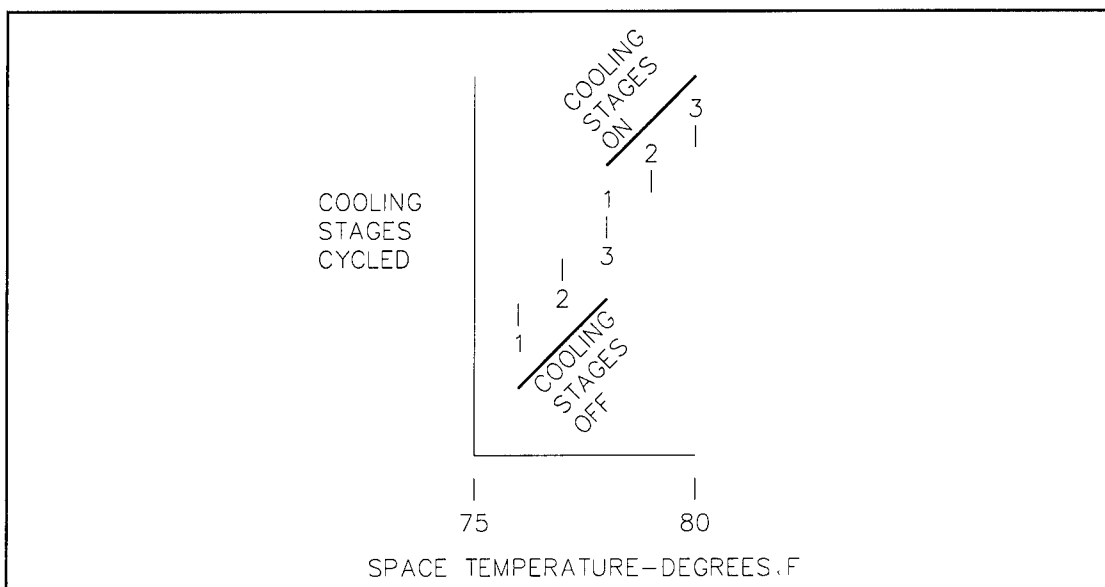

Figure 6. Example of multiposition control.

stages, resulting in a step-like operation. The greater the number of stages or steps, the smoother will be the system's operation. As the load increases, more stages are turned on.

Floating Control

Although this control mode is not used in standard systems, it is discussed here for completeness. In floating control, the controller produces one of three possible outputs: full-forward, zero (i.e., stop), or full-reverse. The logic for selecting its output is based on the value of the process variable and is illustrated in Figure 7. While the process variable is within the neutral zone between the upper and lower setpoints of the controller, the controller produces a zero output (off) and the controlled device maintains a constant setting. When the process variable drifts above the high setpoint, the controller produces a full-forward output that causes the setting of the controlled device to change at a constant rate until the process variable reenters the neutral zone. Ultimately, the process variable reenters the neutral zone, the controller's output goes to zero, and the controlled device maintains a constant setting. No change in the controller's output or the setting of the controlled device will occur until the process variable again drifts out of the neutral zone. This mode is called floating because no control action occurs while the process variable is "floating" between the two setpoints. For good operation, this type of control requires a rapid response of the process variable to changes in the setting of the controlled device; otherwise, the process variable will oscillate wildly and not settle out between the setpoints.

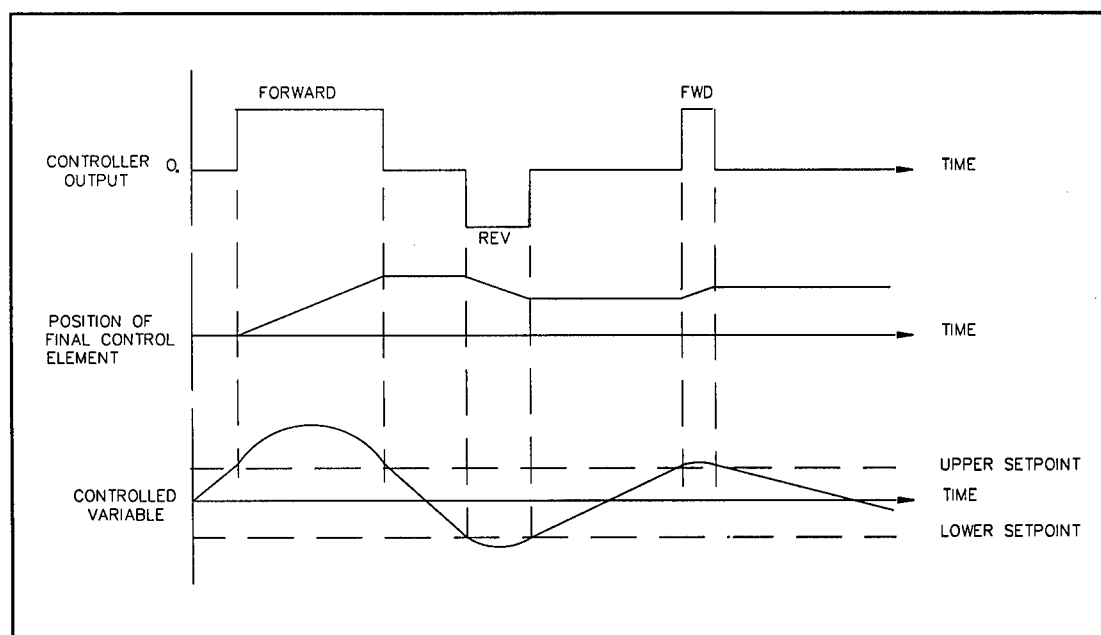

Figure 7. Floating control.

A variation of floating control produces a modulating forward or reverse output signal rather than the full-forward or full-reverse response to the process variable whenever it drifts outside of the neutral zone.

Modulating Control

Modulating control is the type most commonly used in HVAC systems because it allows the most precise control. With modulating control, the controller's output can vary infinitely over the span of its output range. Unlike floating control, the modulating controller may respond to any small changes in the process variable, regardless of the actual value of the process variable, because it has no neutral zone. There are three control modes frequently encountered in modulating control. These are proportional control, proportional-integral control, and proportional-integral-derivative control.

Proportional Control. Proportional control is the simplest of the three modulating control modes. This control mode is used in most pneumatic and many older electronic HVAC control systems. A proportional controller produces a continuous linear output based on the deviation of the process variable from the controller setpoint. This deviation is called the error signal. The controller modulates its output signal in proportion to the error signal.

The sensitivity of a proportional controller to the error signal is called proportional gain. In some HVAC control applications, proportional control may function quite well with a high sensitivity (or high proportional gain) adjustment. A high proportional gain adjustment results in a narrow range of the process variable over which the controller's output ranges from zero output to maximum output. A gain setting that is too high causes the process variable to continuously overshoot and undershoot the setpoint, much like the on-off action controller. In other control applications, stable control may not be achievable with a high gain adjustment. A low gain adjustment results in a wide range of the process variable over which the controller changes its output from zero output to full output, but control is usually more stable. Proportional band is a related but more commonly used term than proportional gain. Proportional band will be defined and discussed later in this report.

Figure 8 illustrates the response of a typical heating system using proportional control. Figure 8 shows the proportional relationship between the controller output and the deviation of the discharge air temperature from setpoint. The coil inlet air temperature provides a load to the system; Figure 8 shows how the system adjusts to this load. When the heating load changes as the result of a change in the coil inlet air temperature, the controller changes its output proportionally to adjust the

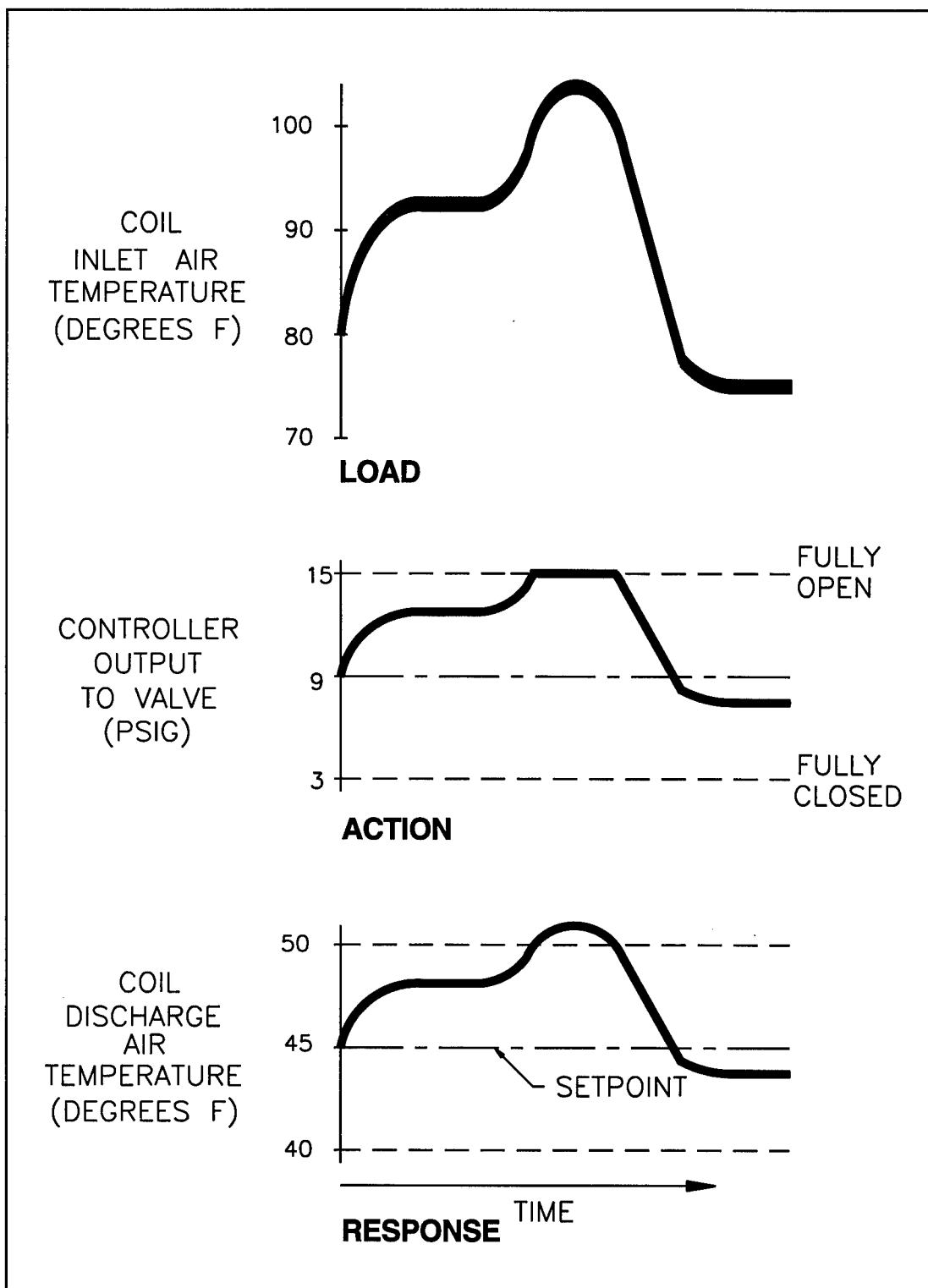

Figure 8. Proportional control.

discharge air temperature of the coil. An initial increase in the outdoor air temperature causes an increase in the discharge air temperature above the setpoint. The controller senses a change and adjusts by opening the cooling valve a proportional amount. In this example, the proportional gain of the controller has been adjusted to operate the valve between 3 pounds per square inch gage (psig) (fully closed valve) and 15 psig (fully open valve) over the discharge air temperature span from 40 to 50 °F, respectively, with a discharge air temperature setpoint of 45 °F. The proportional gain of the controller is:

$$PG = \frac{15 - 3 \text{ (psi)}}{50 - 40 \text{ }^\circ\text{F}} = 1.2 \text{ psi}/^\circ\text{F} \quad [\text{Eq 1}]$$

This example shows that, for every degree change in discharge temperature, the controller output will change by 1.2 psi. Figure 8 shows an increase in controller output to 15 psig when the discharge air temperature reaches 50 °F. At this point, the controller can make no further adjustments to changes in the discharge air temperature because the controller is already at its maximum output and the cooling valve is fully open. This example illustrates a situation in which the cooling coil lacks sufficient capacity to maintain the process variable within the span of the controller for the given load conditions. The controller will resume valve modulation when the air discharge temperature falls back within the span of the controller.

A significant problem with proportional control is related to the fact that it controls by providing an output that is proportional to the system error rather than actually attempting to eliminate the error altogether. Figure 8 shows that, in general, the setpoint is not maintained exactly. There are only two points on Figure 8 at which the discharge air temperature is actually at setpoint. These two points correspond to identical load conditions (an inlet air temperature of 60 °F). For all other load conditions, the discharge air temperature is either above or below setpoint.

The inability of the proportional control mode to maintain the process variable at or near setpoint results in what is commonly referred to as steady state error or offset due to load. This phenomenon is seen as a persistent deviation between the setpoint and process variable at all but one load condition. For a given load, the proportional controller's response results in a system output in proportion to the system error. The system's output and the load ultimately reach equilibrium. Unfortunately, at equilibrium the process variable will typically not be at setpoint because the system's output is exactly equal to the load on the system with the process variable still differing from the setpoint. As long as the load remains constant, the offset also will remain constant. Should the load change, the offset also will change, but it will not be eliminated except at the particular load condition that balances with the

system's output corresponding to a zero error. The existence of this persistent offset adversely affects system accuracy, comfort, and energy consumption.

Upon inspecting Figure 8, one might wonder why the controller is producing a nonzero output when the system error is zero (i.e., the process variable is at the setpoint). The algorithm for the percent output (OUT) of a proportional controller consists of two components, as seen in Equation 2, and is dependent not only on the error signal but also on the value of the manual reset (MR), the sensor span (SS), and the proportional band (PB). The form of the proportional-only algorithm is:

$$\text{OUT (\%)} = \text{MR} + \frac{100^2 \times \text{Error}}{\text{SS} \times \text{PB}} \quad [\text{Eq 2}]$$

In Equation 2, MR is the output of the controller (measured in percentage of full output) when the process variable and the setpoint are equal (i.e., the system error is zero). As its name implies, the MR term can be adjusted by the operator to eliminate offset. By increasing or decreasing the manual reset adjustment, the controller output will increase or decrease respectively.

In Equation 2, SS is the range over which a given sensor measures and transmits the value of the process variable. Sensor spans for various sensing devices are specified in CEGS-15950. According to CEGS-15950, the required temperature range for a device used to measure and transmit the temperature of the discharge air from a heating coil is 40 to 140 °F, which yields a sensor span of 100 °F.

PB is directly related to the ratio of the range of the process variable over which the controller's output changes from its minimum to maximum values and the SS. PB is referred to as the proportional band mode constant (per CEGS-15950 and TM 5-815-3) and is defined mathematically in Equation 3. It is multiplied by 100 so it may be measured in units of percentage. This also is explained in TM 5-815-3.

$$\text{PB} = \frac{\Delta\text{PV} \times 100}{\text{SS}} \quad [\text{Eq 3}]$$

In Equation 3, ΔPV is the range of the process variable over which the controller is to span its full range of output. The factor of 100 is included in Equation 3 so PB also will have units of percent. PB can be thought of as the percentage of a particular SS within which the controller's output is proportional to the sensor's input. For a direct-acting controller, for example, the controller produces its minimum output for sensor inputs at the lower end of the PB and its maximum output for sensor inputs at the upper end of the PB. For a large (or wide) PB, a rather large change

in the sensed value of the process variable is required to affect a full span change in the output of the controller. Likewise, a small (or narrow) PB requires a relatively small change in the sensed value of the process variable to cause a full scale change in the controller's output. A wide PB setting results in a control algorithm that is less responsive to process variable changes than a narrow PB setting.

As noted here, the algorithm for a controller must be either direct- or reverse-acting. A direct-acting control algorithm produces an increase in output as the process variable increases, and a reverse-acting algorithm shows an increase in output as the process variable decreases. Therefore, error in Equation 2 is defined as

$$\text{Error (Direct-acting)} = PV - SP \quad [\text{Eq 4}]$$

$$\text{Error (Reverse-acting)} = SP - PV \quad [\text{Eq 5}]$$

where:

PV = process variable measured by the sensor SP = setpoint.

In some heating applications a controller operating in the proportional-only mode is required. An example of a direct-acting, proportional-mode controller application is a heating coil discharge air temperature controller. The flow of hot water to the coil is controlled by a normally open valve. As the discharge air temperature increases, the output of the controller also will increase, thus forcing the valve to close. The sensor span for this process, as suggested here, would be from 40 to 140 °F for a total span of 100 °F.

Figure 9A illustrates the input/output relationship for a direct-acting heating coil controller, assuming the controller to be configured for an MR value of 50 percent, a setpoint of 90 °F (at the midpoint of the process variable temperature range), and a PB setting of 100 percent (i.e., the range of the process variable over which the controller spans its full output range is also 40 to 140 °F). When the process variable equals the setpoint, 90 °F, the output from the controller is 50 percent as the definition of MR states. The direct action of the controller can be seen by looking at the output of the controller when the process variable is above or below the setpoint. As the process variable drops below the setpoint, the system error becomes negative and the output drops proportionally. At a process variable of 40 °F, the controller output is zero percent. Likewise, as the process variable rises above the setpoint, a positive system error results and the controller output increases above 50 percent.

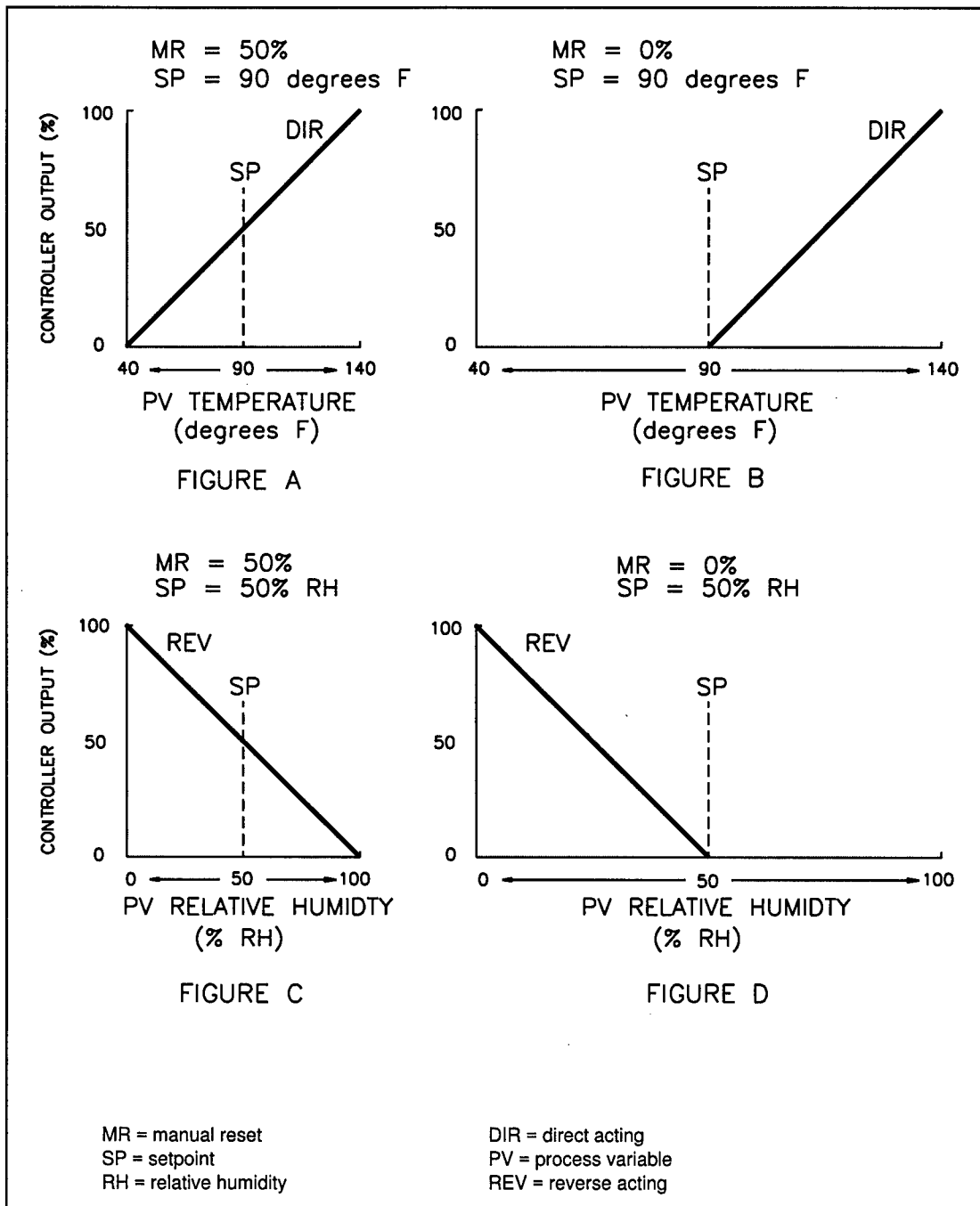

Figure 9. Manual reset, direct- and reverse-acting control modes.

In Figure 9B the MR value is set at zero percent and the PB, setpoint, and direct action of the controller remain the same as in Figure 9A. With the process variable at setpoint, the output of the controller is zero percent, which again reflects the definition of MR. The direct action of the controller and the effect of an MR value of zero percent can be seen by looking at the process variable. Until the process variable reaches a value above the setpoint, the output of the controller remains at zero percent because the controller cannot give an output below zero percent.

A reverse-acting, proportional-only controller might be employed in an application that controls space relative humidity. The humidity is manipulated by a normally closed valve. As the process variable (space relative humidity) increases, the output decreases, thus causing the valve to close. The process variable ranges from 0 to 100 percent relative humidity. The input/output relationship for a reverse-acting controller is illustrated by Figures 9C and 9D. In Figure 9C the setpoint is assigned a value of 50 percent relative humidity, the PB remains at 100 percent, and the MR is set at 50 percent. When the process variable equals the setpoint of 50 percent, the output of the controller is at 50 percent, the MR value. As the process variable increases, the output decreases. The output is below 50 percent when the process variable is above the setpoint, and the output is above 50 percent when the process variable is below the setpoint of the controller. In Figure 9D, the MR value is set at zero percent and all the other parameters in Figure 9C remain the same. Figure 9D illustrates that, because the output of the controller is at zero percent at the setpoint and the controller is reverse-acting, as the process variable increases above the setpoint, the output does not change because the controller has already reached its minimum output value of zero percent.

In a practical heating coil control system, the results obtained with the control parameters used in Figure 9A would probably be unsatisfactory because the controller's sensitivity to changes in the system error is extremely low. In other words, the PB is extremely wide so a large change in system error is required to cause the controller to produce a significant change in its output. As a result, the process variable will likely experience wide excursions from the setpoint. One way to correct this is to decrease (or narrow) the PB. This is accomplished by decreasing the span of temperature over which the process variable must vary to produce a full-scale change in the controller's output.

Figure 10A is identical to Figure 9A in that MR = 50 percent, setpoint = 90 °F, and SS = 100 °F. The PB for the system shown in Figure 10A is seen as the ratio (in percent) of the width of the process' proportional bandwidth to the SS and is equal to:

$$PB = \frac{(140^{\circ} - 40^{\circ}) \times 100}{140^{\circ} - 40^{\circ}} = 100 \text{ percent} \quad [\text{Eq 6}]$$

In Figure 10B, all parameters are the same except that the PB is decreased. The PB is recalculated to be:

$$PB = \frac{(100^{\circ} - 80^{\circ}) \times 100}{140^{\circ} - 40^{\circ}} = 20 \text{ percent} \quad [\text{Eq 7}]$$

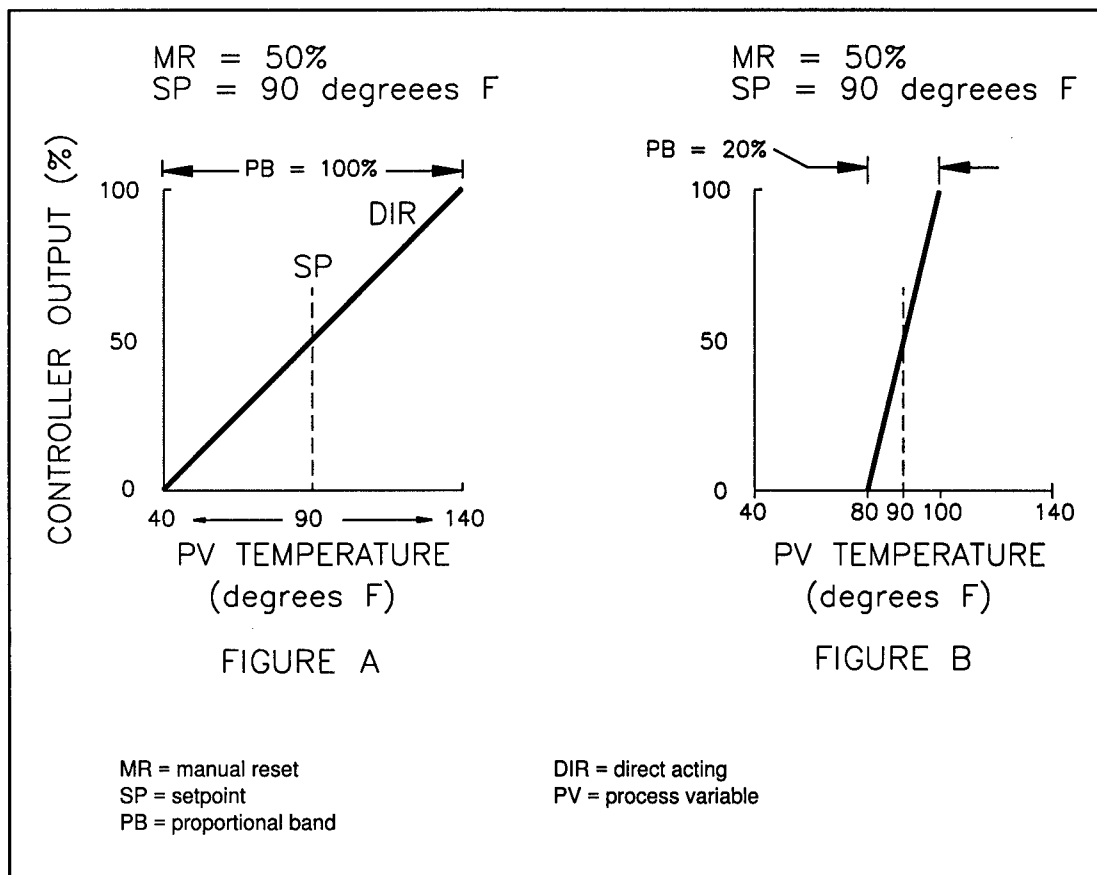

Figure 10. Examples of wide versus narrow proportional band.

The proportional bandwidth in Figure 10B is much narrower than in Figure 9A. As a result, a system operating with this PB setting will give much more responsive and, probably, more satisfactory control because it will attempt to maintain the process variable within a much narrower temperature range about the setpoint. In addition, the offset due to load will be greatly reduced with a narrower PB setting.

One might be tempted to think that, if narrowing the PB setting a certain amount produced tighter and more responsive control, then narrowing it even more should be even more desirable. In fact, one might wonder if it might be possible to eliminate offset entirely by making the PB sufficiently narrow. Unfortunately, one would find that there is a practical limit to the amount the PB can be reduced. If the PB is set at too narrow a value, the system will become so sensitive to minute changes that the controller will cycle wildly between its maximum and minimum output levels. The controlled device will exhibit the same behavior. The system will be effectively out of control. Ideally, one should try to set the PB at a value that maintains the process variable within a reasonably narrow region about the setpoint and experiences a minimum amount of oscillation about the setpoint. A certain amount of offset due to load is an inevitable fact of life. As long as the proportional controller is controlling in a stable fashion at some control point near the setpoint

and the PB setting is optimal, the controller has achieved the most precise control, at varying load conditions, of which it is capable.

Proportional-integral Control. Many control applications require a controller that can eliminate offset due to load and can maintain the process variable very close to setpoint. The method used to adjust the controller output to eliminate offset is called integral mode. Integral mode adds an additional gain component directly to the controller output. The effect of this term is that the controller will continue to adjust its output as long as any error persists, and the control offset ultimately will be eliminated. The algorithm for the percentage output of a proportional-integral (PI) controller is shown in Equation 8.

$$\text{OUT (\%)} = \text{MR} + \frac{100^2}{\text{SS} \times \text{PB}} \left[\text{Error} + \frac{\Delta T \times \Sigma \text{Errors}}{\text{IC}} \right] \quad [\text{Eq 8}]$$

In this equation, MR, SS, PB, and Error are defined as they were in Equation 2. ΣErrors stands for a summation of the system error. The error is summed (or added) at a time increment defined by ΔT , which is the time interval between consecutive measurements of the system error. This value is factory preset within the controller. IC represents the integral mode constant, the factor which is user adjustable to determine the controller's response to an accumulation of system error over time. The units of IC in Equation 8 are seconds per repeat. It can be seen in Equation 8 that, by increasing IC, the gain of the controller decreases. Likewise, by decreasing IC, the controller gain increases. A slight variation of Equation 8 is shown in Equation 9. In this equation, IC appears in the numerator and a factor of 60 appears in the denominator. For this PI algorithm, the unit of the integral mode constant is repeats per minute. This form of the algorithm is less typical than that shown in Equation 8. Note that in Equation 9 an increase in IC increases the gain of the controller, and a decrease in IC decreases the gain of the controller. This is the only difference between the two algorithms, otherwise they are functionally the same.

$$\text{OUT (\%)} = \text{MR} + \frac{100^2}{\text{SS} \times \text{PB}} \left[\text{Error} + \frac{\Delta T \times \text{IC} \times \Sigma \text{Errors}}{60} \right] \quad [\text{Eq 9}]$$

Starting with $\Sigma \text{Errors} = 0$, the PI controller calculates the error signal at frequent, regular time increments (ΔT) and maintains a running sum of these errors. It then divides this sum by the time elapsed since the beginning of the error summation. This procedure results in an instantaneous averaged error that the controller uses to provide the integral mode's contribution to the total output. After a given amount

of time (as determined by the integral mode constant's setting), the Σ Errors term and the elapsed time are reset to zero and the process is repeated.

The integrating function of a PI controller is illustrated in Figure 11. The horizontal axis shows time in seconds, the vertical axis shows the controller OUT. The controller output is shown for three different values of the integral mode constant. It is important to realize that the illustration shows OUT under the condition that the setpoint is fixed and the process variable is not changing, in other words, the controller error signal is constant.

The starting point of the integration (at time = 0) is with OUT at 10 percent; this value of OUT is due to the proportional part of the PI algorithm. For example, if we assume that the range of the process variable (sensor span) is 0 to 100 °F, the PB setting is 100 percent, and there is an error of 10 °F, then OUT will be 10 percent per Equation 8. The value of OUT due to the proportional part of the algorithm does not change as a function of time; it is strictly dependent on the error. With the error held constant, as in Figure 11, OUT due to the proportional part of the algorithm will always be 10 percent. This value of OUT is defined as one "repeat."

As integration begins (Figure 11), the rate of the integration (summation of the errors) is a function of the I mode constant. With I equal to 60 seconds per repeat (sec/rpt) the output from the controller, after 60 seconds, will repeat (or duplicate) the output from the controller due to the proportional part of the algorithm. Therefore after 60 seconds:

$$\text{OUT} = \text{P} + \text{I} = 10\% + 10\% = 20\% \quad [\text{Eq 10}]$$

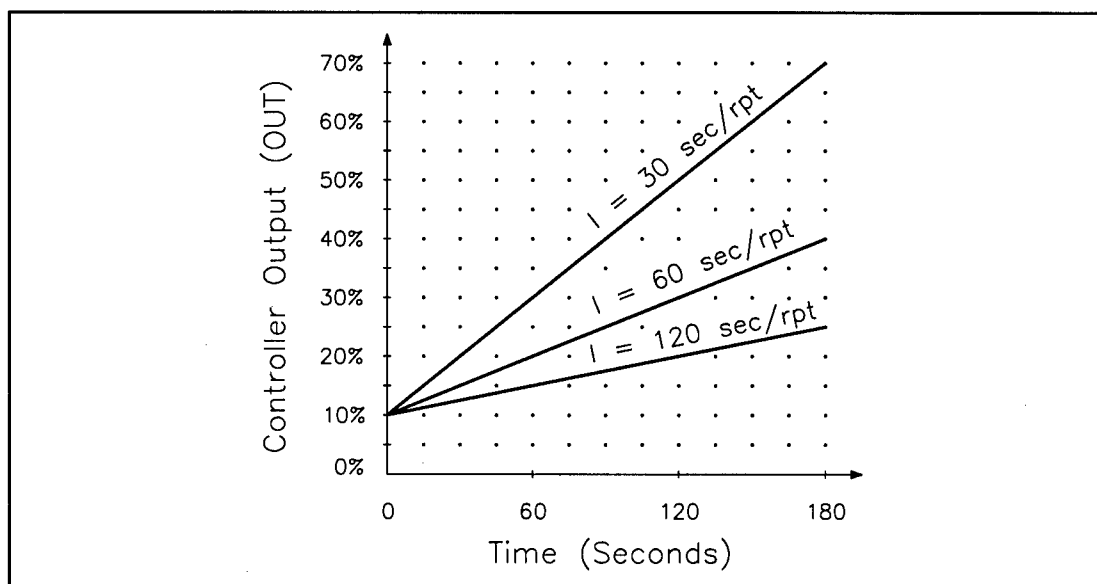

Figure 11. Definition of integral mode constant.

Because each repeat equals 10 percent, after 120 seconds the value of OUT is 30 percent. After 180 seconds, OUT is 40 percent, etc. In short, the output from the controller due to the proportional-only part of the PI algorithm is repeated every X-seconds, where X is the I-mode integration constant.

Under the same conditions, with the I-mode constant set at 120 sec/rpt, the output from the controller will equal 15 percent after 60 seconds because it achieves only half of a repeat (5 percent) during that interval. After 120 seconds, a full repeat is achieved and the controller output equals 20 percent.

Note that the speed of the controller response is half as fast at an I-value of 120 than it is at an I-value of 60. In terms of gain, the controller gain is larger at the lower I-value.

A less common way of expressing the I-mode constant is in units of repeats per minute (rpt/min). An I-mode constant setting of one repeat per minute is identical to an I-mode constant setting of 60 seconds per repeat. Table 1 shows other equivalencies. Note that, when the I-mode constant is in units of repeats per minute, the larger the value of the I-mode constant, the larger the controller gain. This is in contrast to units of seconds per repeat. With the integral mode added to proportional control, the output signal from the controller is varied in proportion to both the instantaneous system error and the length of time that any error persists. The final control element continues to move in a direction to correct the error. It will stop modulating only when the error signal becomes zero, at which time the process variable is at the setpoint. Because of the combined action of both these control modes, the controller can reduce the offset to zero, or nearly zero, and can establish a steady state equilibrium of HVAC system control at a value very near setpoint.

An important feature of Equations 8 and 9 is the fact that both the proportional and integral responses of the controller are affected by the PB setting. This parameter is multiplied times both terms within the brackets of these equations. As a result, it should be kept in mind that changes in the PB setting will affect more than just the proportional response. It also should be pointed out that the MR term is insignificant in PI control; some PI algorithms do not include it because it has little to no impact on the performance of the algorithm.

Table 1. Integral mode constant unit equivalencies.

| Seconds per repeat (sec/rpt) | Repeats per minute (rpt/min) |
|---------------------------------|---------------------------------|
| 30 | 2 |
| 60 | 1 |
| 120 | 1/2 |

Figure 12 illustrates PI control. Figure 12 shows the same conditions as in Figure 8 to provide a comparison of the P-mode output (solid lines) versus the PI-mode output (dashed lines). Figure 12

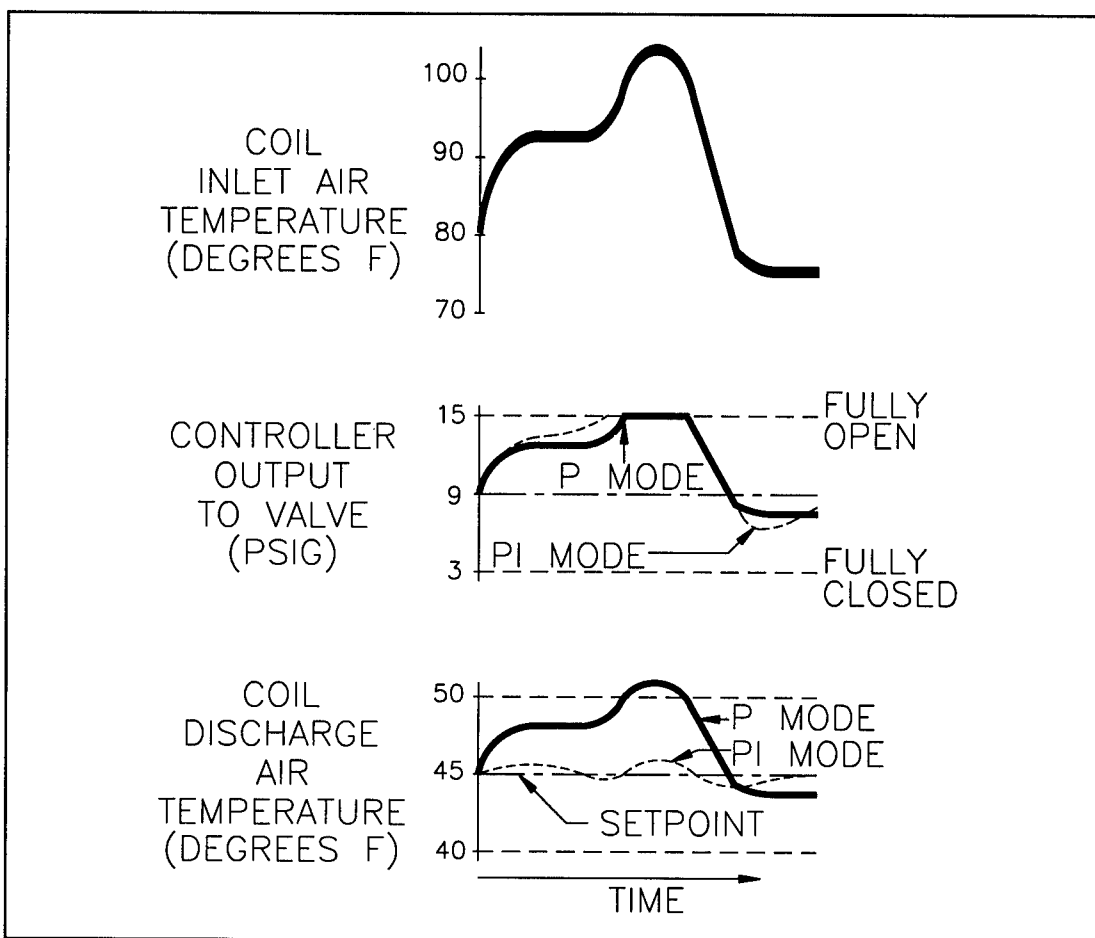

Figure 12. Proportional-integral control.

shows that PI control maintains the discharge air temperature at or near the setpoint even for a large, sustained load. The proportional part of this mode adjusts to changes in the error signal, and the integral part adjusts to eliminate offset in the system. However, when the controller exceeds its output range, the controller is saturated and is unable to adjust further. In this case, even PI-mode control may have an offset because, at this load condition, the system lacks sufficient capacity to meet the load.

The rate of change of load imposed on a system also may affect how well the controller will maintain the process at setpoint. Fortunately, most independent variables in HVAC applications, such as outside air temperature, change relatively slowly. Because of these relatively low rates of change, most HVAC processes can be controlled quite well with PI control.

Proportional-integral-derivative Control. Some processes require a controller that can respond to a rapidly changing process variable. One answer to the control of such a process is the addition of another control mode called derivative mode. When this control mode is added to PI control, the combination is known as proportional-

integral-derivative (PID) control. The D-mode adds another gain component to the output signal. With PID control, the output from the controller is varied in proportion to the rate at which the disturbance takes place. It is used to accelerate the return of the process variable to the setpoint in a part of the process that is slow in responding and to anticipate an overcorrection to the disturbance that will cause an overshoot and start corrective action to prevent it. A rapid change in the error signal will increase the absolute value of the derivative term. A small rate of change will produce a small value in the deviation term. For constant error values, the derivative mode has no effect.

The PI-mode is quite effective at controlling processes across the full range of system loading as long as the load does not change too rapidly. However, the PI-mode alone cannot adequately handle the unpredictable diversity of a rapidly changing process. As an example, a domestic hot water system using a tankless heating convertor might be controlled using a PI-mode controller. As long as the hot water demand was relatively constant, the PI controller would maintain the water temperature close to the setpoint. However, if after a period of low demand there were to be a sudden surge in demand, the PI-mode controller would be unable to respond rapidly enough to the change in demand, and the water outlet temperature would drop noticeably. The addition of the derivative mode could help the controller maintain setpoint during periods of rapidly changing demand in such applications. However, because most HVAC systems have a relatively slow response to changes in controller output, the use of derivative mode may tend to over control. Only when system response is very rapid should PID-mode be considered.

The effect of adding I- and D-modes to the P-mode is illustrated in Figure 13, which shows the results that would be expected with a step change in setpoint.

When using any combination of control modes (PI, PD, or PID), the relative strengths of each mode must be adjusted to match the characteristics and responses of the process being controlled. The proportional gain determines the sensitivity of the proportional action. However, higher sensitivity may introduce instability into the system. Integral and derivative controls are time dependent and help to remove the offset and speed up the response. The integral part of the control is used to reduce the steady state error to zero, and the derivative control is used to speed up the action of the controller's response. The optimum parameters for each control mode vary for different systems. Therefore, a thorough understanding of controller functions is vital to understanding system operation.

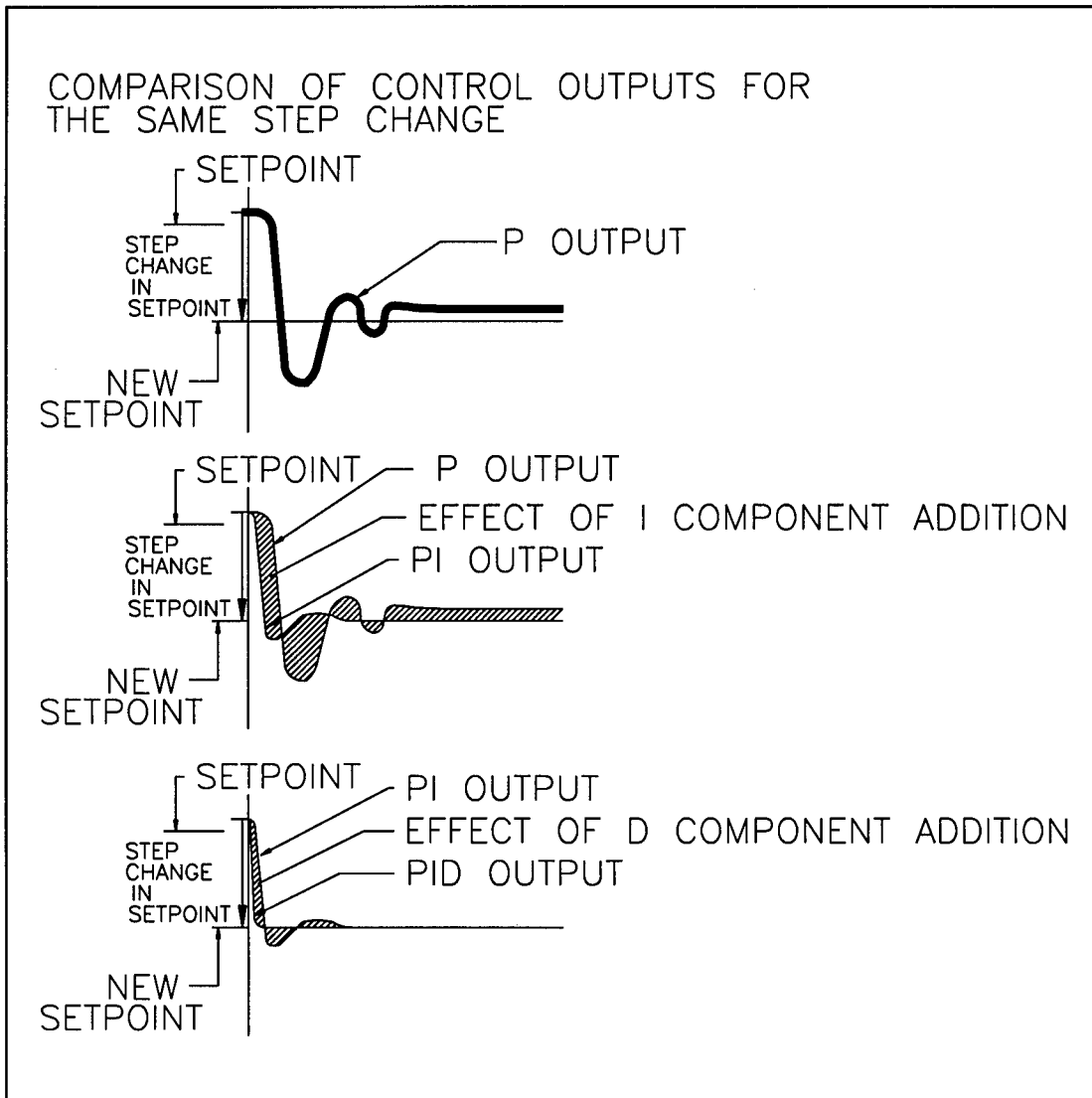

Figure 13. Proportional-integral-derivative control.

4 Standard HVAC Control Systems and Loops

Standard HVAC Control Systems

A control system is comprised of various control loops, assembled together to perform functions necessary for maintaining desired environmental conditions in a building or space. The standard control systems, defined in TM 5-815-3 and CEGS-15950, consist of more than 20 different HVAC control systems, including air-side controls, water-side controls, and packaged or unitary controls.

Standard Control Loops

The standard HVAC control loops described in this chapter consist of various control devices arranged to perform specific tasks, such as to control a heating coil valve. All control hardware is identified using symbology and identifiers based on Instrument Society of America (ISA) symbols. A complete symbols list is in Appendix A. A circle, also referred to as a bubble, is the most common symbol used in the control drawings. As illustrated in Figure 14, a bubble with a horizontal line through it represents a control device located inside a control panel (a panel-mounted device). A bubble without a line through it represents a control device located external to a control panel (a field-mounted device).

To uniquely identify each control device, a naming convention was established based on ISA standards. The “unique identifier” for each device consists of two parts. The upper field of the instrument symbol shows the function of the device, and the lower field is used to show the system/device number. The upper field is limited to four alpha characters and the lower field to four alphanumeric characters. This is illustrated in Figure 15.

There are no ISA symbols or identifiers applicable to HVAC equipment components. Therefore, symbols and unique identifiers were developed for HVAC equipment elements. These are included in Appendix A of TM 5-815-3. The basic functional shape chosen was a hexagon with a bisecting line as illustrated in Figure 16. The upper half of the hexagonal symbol contains up to four alpha characters to describe

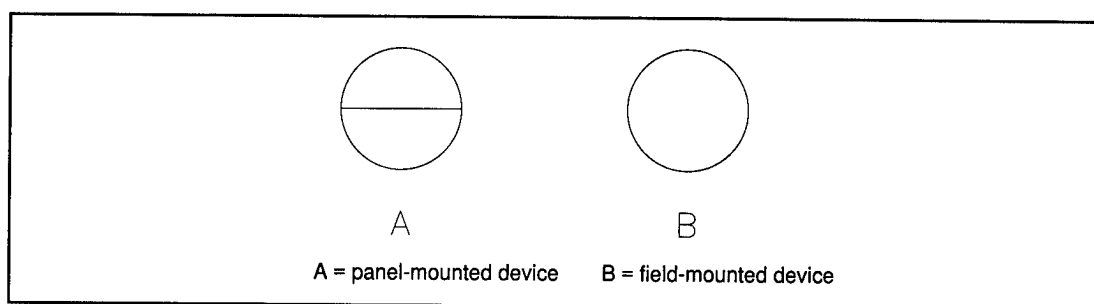

Figure 14. Control device symbols.

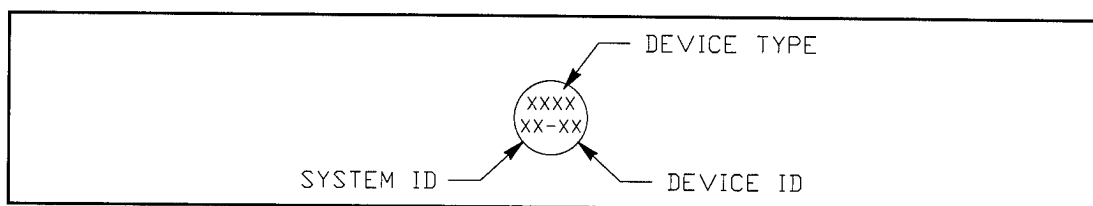

Figure 15. Unique identifier naming convention.

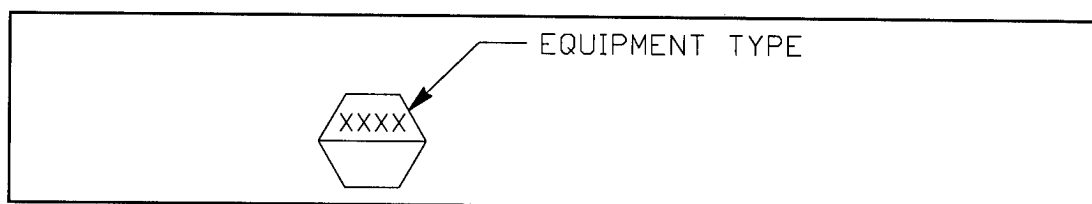

Figure 16. Symbol for an HVAC equipment element.

the device's function. The functional identifier used is derived from the name of the device, such as "EF" for exhaust fan.

Preheat/Heating Coil Loop

Sometimes the required minimum quantity of outside air, when mixed with return air, will produce a mixed air temperature that is too low for the HVAC system to function properly. Preheating raises the temperature of outdoor air before introducing it into the rest of the HVAC system. Preheat coils generally are used to avoid freeze-up of chilled water or hot water coils downstream of the mixed air plenum. Preheat coils can use either hot water, hot glycol, or steam. The temperature of air leaving the coil can be controlled by monitoring either the outdoor air temperature or the discharge air temperature.

The standard outside air preheat coil temperature control loop is shown in Figure 17. This modulating control loop can be used only with hot water or hot glycol preheat units. The loop controls the temperature of the air leaving the

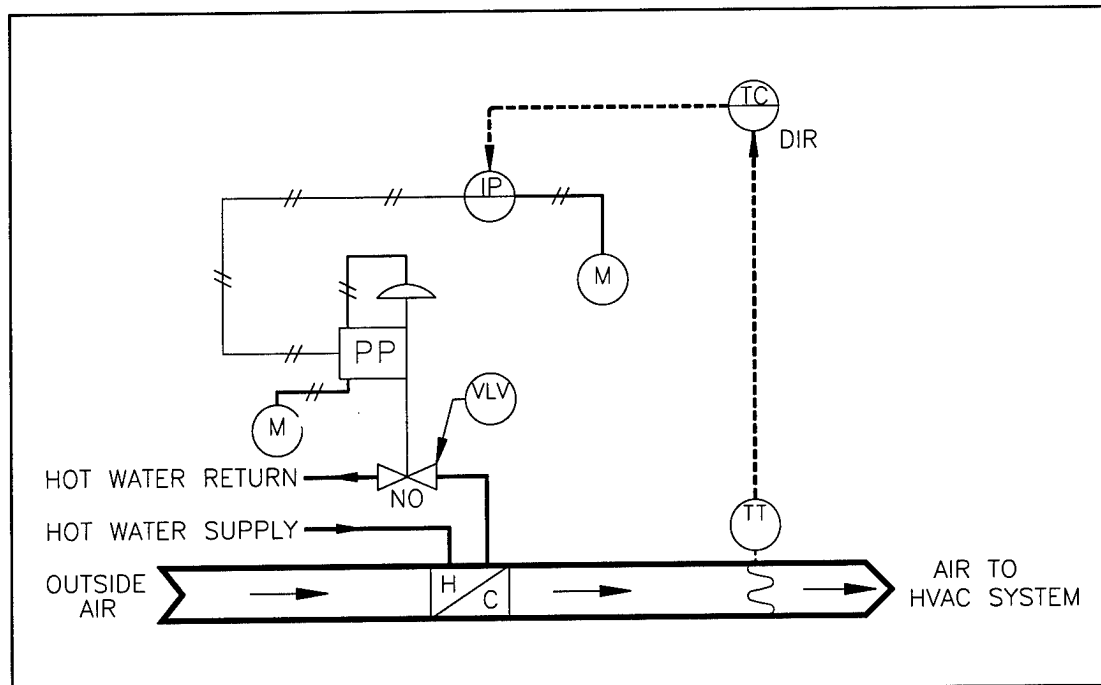

Figure 17. Preheat coil temperature control loop.

preheat coil before the air mixes with return air. A variation of this control loop, applicable to steam heating systems, can be found in TM-5-815-3.

As shown in Figure 17, temperature-sensing element and transmitter, TT, which is located in the discharge air stream from the preheat coil, sends a temperature signal to temperature controller TC. Controller TC, operating through transducer IP, maintains the air temperature leaving the coil at the setpoint of the controller by modulating valve VLV. The component labelled M in Figure 17 is the main air supply to the IP, and the positive positioner for valve VLV is labeled PP.

The setpoint of the controller of this loop is the HVAC system designer's calculation of the coil discharge air temperature required to maintain the desired minimum temperature in the mixed air plenum when the outside air temperature is at the design condition. This setpoint assures an adequate minimum temperature entering the cooling coil of an HVAC system. Because the TC setpoint is normally in the range of 40 to 55 °F, the valve is typically controlled only during the heating season when the outside air temperature is below the TC setpoint. When the outside air temperature is at or above the TC setpoint, VLV is closed. In this control loop, TC is direct-acting (DIR). Valve VLV is normally open (NO) and fails in the fully open position under the pressure of the valve actuator's return spring on a loss of electric signal, pneumatic signal, or PP air supply. This avoids freezing of the preheat coil and other coils in the HVAC system if a control system failure occurs in cold weather. The preheat coil control loop functions continuously, without regard to the

operating condition of the rest of the HVAC system. This has the advantage of maintaining a minimum temperature in the ductwork when the HVAC system supply fan is off.

A heating coil in an HVAC system may be controlled using exactly the same control loop if the desired leaving air temperature of the coil has a fixed setpoint. Typically, however, the desired heating coil leaving air temperature is scheduled as a function of the outside air temperature to improve space comfort conditions and reduce system energy consumption.

Heating Coil Loop and Outside Air Setpoint Reset

Some standard systems contain a heating coil temperature control loop with the desired coil discharge air temperature scheduled from the outside air temperature. A typical temperature reset schedule, as illustrated in Figure 18, for the heating coil leaving air temperature in a mild climate is 115 °F at 0 °F outside air temperature and 90 °F at 60 °F outside air temperature. This loop is typically used to control heating coils for multizone or dual-duct HVAC systems.

Figure 19 shows a temperature-sensing element and temperature transmitter TT in the outside air intake of the HVAC system. The TT sends a signal to the process variable input PV of controller TC (REV). Controller TC (REV) reverses its output signal relative to the outside air temperature transmitter signal. Reversing the signal is necessary because there must be an inverse relationship between the outside

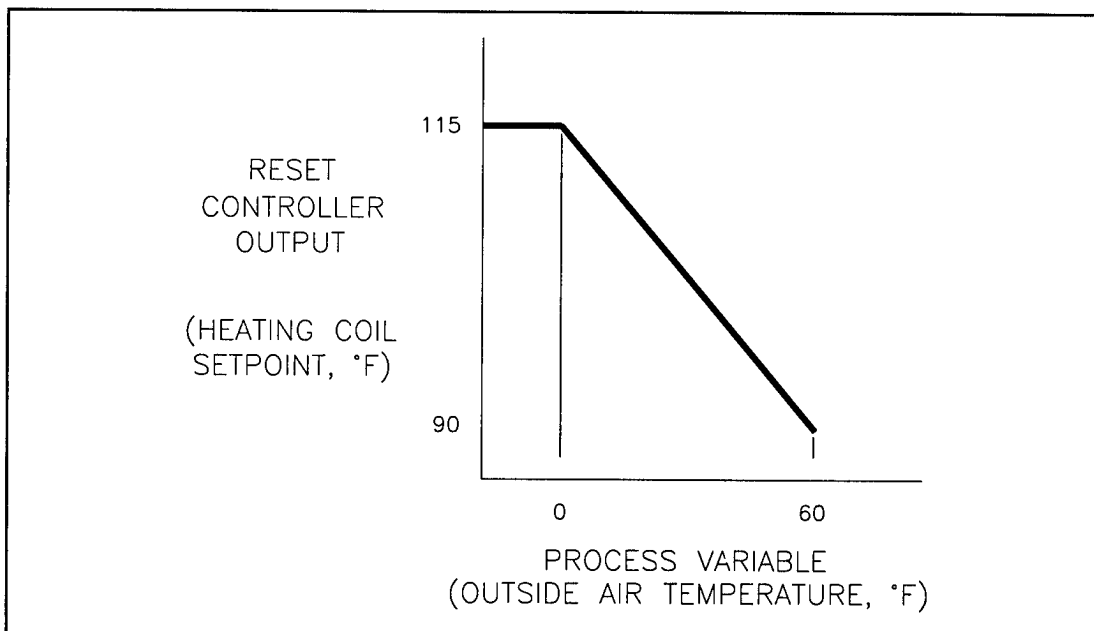

Figure 18. Typical heating coil discharge air temperature reset schedule.

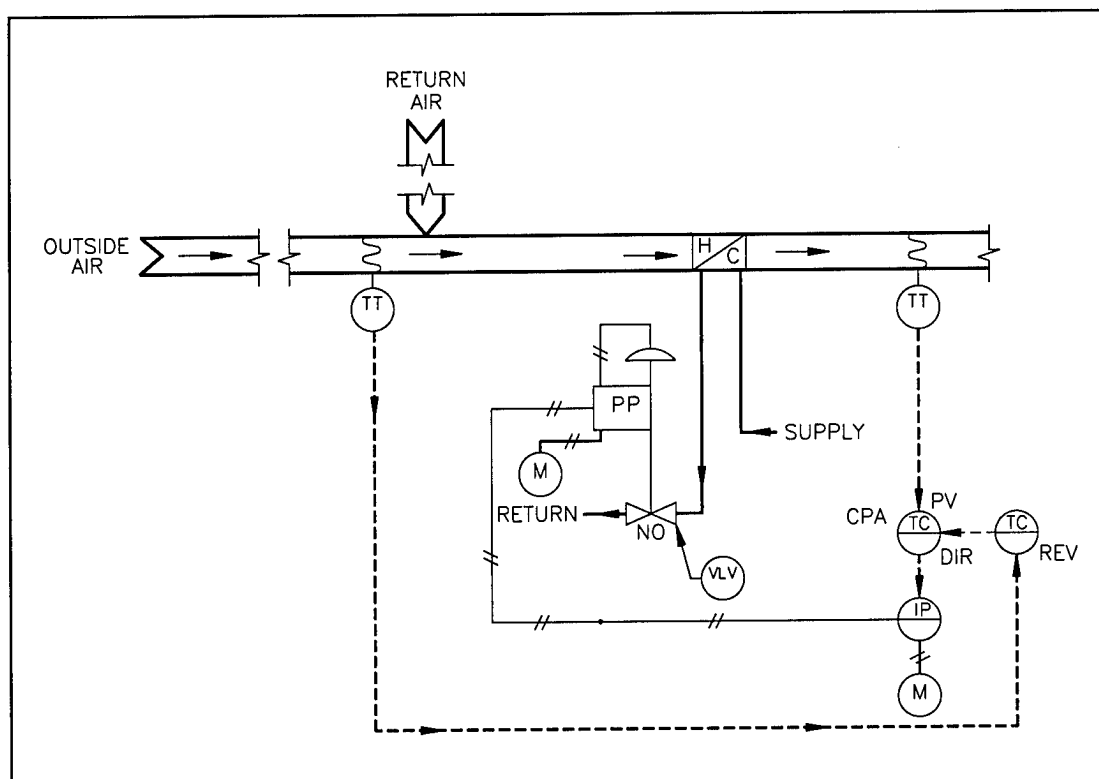

Figure 19. Heating coil loop with outside air reset.

air temperature and the resulting setpoint of heating coil controller (i.e., as the outside air temperature decreases, the heating coil controller setpoint must increase). The reset controller TC (REV) scales its output according to its input to provide the temperature schedule for the heating coil controller TC (DIR). Thus, the temperature-sensing element and transmitter TT in the outside air duct signals TC (REV) to lower the TC (DIR) setpoint according to a linear schedule as the outside air temperature increases. The temperature-sensing element and transmitter TT in the coil discharge air stream send a signal to process variable input PV of TC (DIR). Controller TC (DIR) operates heating coil valve VLV through transducer IP and positive positioner PP. The limits of the control point adjustment (CPA), or remote setpoint input, of TC (DIR) must be set to prevent the temperature schedule from exceeding the desired maximum and minimum temperature limits for the coil's discharge air temperature.

In this control loop, valve VLV is normally open (NO) and fails in the fully open position under the pressure of the valve actuator's return spring on a loss of electric signal, pneumatic signal, or PP air supply. This avoids freezing of the heating coil and other coils in the HVAC system if a control system failure occurs in cold weather.

Reset schedules may be used on heating coils to reset the discharge air temperature, or they may be used in hydronic heating applications to reset the temperature of the hot water. Four configuration parameters must be keyed into the single-loop digital controller to establish a reset schedule. These are the setpoint, the PB, the maximum controller output signal, and the MR setting; they can be found on the equipment schedule.*

As an example of the calculations necessary for determining the reset controller's configuration parameters, consider a typical design that is based on a 200 °F heating water temperature at an outside design temperature of 0 °F. This is design point "a" in Figure 20. Assume that, at an outside temperature of +30 °F, a heating water temperature of 165 °F can easily satisfy the load. This is design point "b." In addition, the design requires that the heating water temperature never exceeds 200 °F regardless of the outdoor temperature. The solid line shown in the reset schedule of Figure 20 represents these conditions. Based on this information, the configuration parameters for the reset controller can be calculated.

Note that design points "a" and "b" are used only to define the slope of the reset schedule line. Point "a" need not correspond to the maximum hot water setpoint. The flattened off portion of the reset schedule, corresponding to the maximum hot water setpoint, is defined using a separate controller configuration parameter that is described at the end of this section.

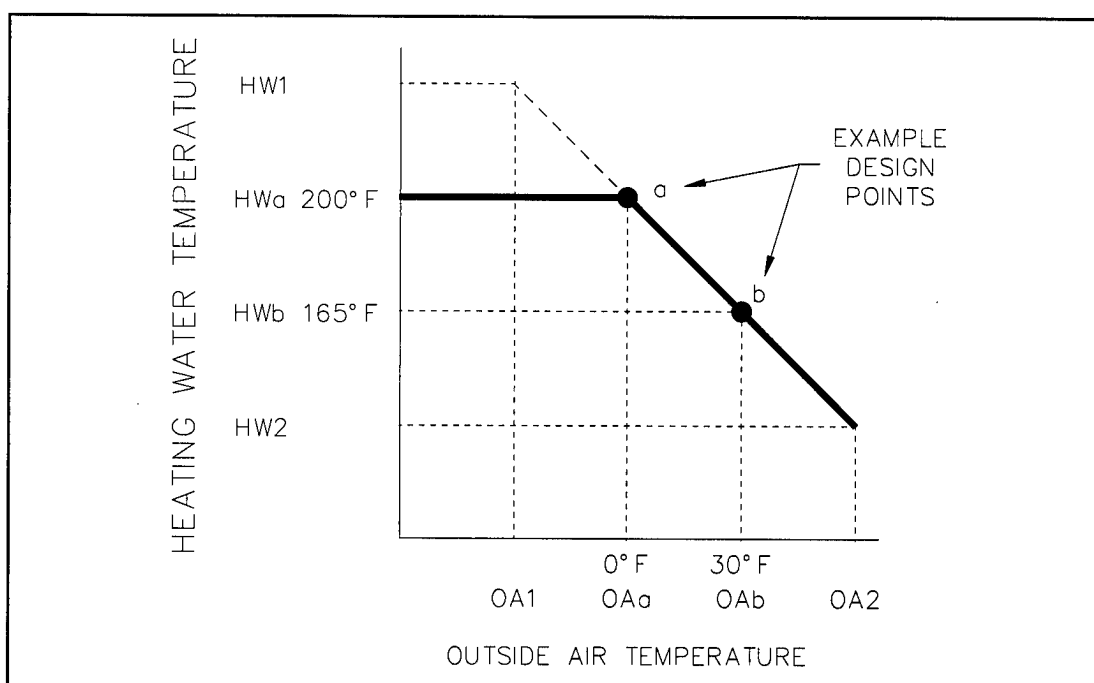

Figure 20. Example reset schedule.

* The equipment schedule is provided with the contractor submitted O&M documentation.

An important consideration in the following calculations is that CEGS-15950 requires a heating water temperature transmitter to have a span of 100 °F to 250 °F. The CPA input to the hot water temperature controller from the reset controller must be scaled to this same range. Therefore, when the reset controller output is 20 mA, the setpoint of the hot water temperature controller will be 250 °F; and, when the output is 4 mA, the setpoint will be 100 °F. This span defines the values of HW_1 and HW_2 in Figure 20.

Given the values of HW_1 and HW_2 ($HW_1 = 250$ °F and $HW_2 = 100$ °F), their corresponding points on the reset schedule line, OA_1 and OA_2 , can be found if the slope of the line is known. The slope of the line can be calculated from the two design points, as follows:

$$\text{Slope} = \frac{HW_a - HW_b}{OA_a - OA_b} = \frac{200 - 165}{0 - 30} = -1.17 \quad [\text{Eq 11}]$$

OA_1 , corresponding to HW_1 , can be calculated by again using the slope equation, the calculated slope, and one of the design points on the reset schedule line:

$$\text{Slope} = \frac{HW_1 - HW_a}{OA_1 - OA_a} \quad [\text{Eq 12}]$$

Rearranging Equation 12 gives:

$$OA_1 = \frac{HW_1 - HW_a}{\text{Slope}} + OA_a = \frac{250 - 200}{-1.17} + 0 = -42.7 \text{ °F} \quad [\text{Eq 13}]$$

Similarly, OA_2 can be calculated:

$$OA_2 = \frac{HW_2 - HW_a}{\text{Slope}} + OA_a = \frac{100 - 200}{-1.17} + 0 = 85.5 \text{ °F} \quad [\text{Eq 14}]$$

The PB setting (in percent) for the reset controller is the throttling range of the process variable (OA_2 minus OA_1 in this example) divided by the sensor span of the reset (OA) controller:

$$\text{PB} = \frac{(OA_2 - OA_1) \times 100}{\text{OA Sensor Span}} = \frac{(85.5 + 42.7) \times 100}{(130 + 30)} = 80.1 \text{ \%} \quad [\text{Eq 15}]$$

The reset controller SP is the midpoint of the throttling range.

$$SP = \frac{OA_2 - OA_1}{2} + OA_1 = \frac{85.5 - 42.7}{2} + 42.7 = 21.4 \text{ } ^\circ\text{F} \quad [\text{Eq 16}]$$

The MR configuration parameter must be set to 50 percent (because the controller setpoint is at the midpoint of the throttling range).

In the example, the setpoint is to be limited to 200 °F (Max SP). The maximum output configuration parameter limits the setpoint of the temperature controller that the reset controller is resetting. The "Max Output" is specified as a percentage of the signal output where 0 percent corresponds to 4 mA and 100 percent corresponds to 20 mA. The hot water controller recognizes a 4 mA CPA input as 100 °F (Lo Span) and a 20 mA CPA input as 250 °F (Hi Span). This is the span of the hot water temperature controller (HW Span). Equation 17 calculates the reset controller's maximum output (Max Out). If the output of the reset controller is limited to 67 percent of its maximum output (14.7 mA), the heating water setpoint will never exceed 200 °F.

$$\text{Max Out} = \frac{(\text{Max SP} - \text{Lo Span}) \times 100}{\text{HW Span}} = \frac{(200 - 100) \times 100}{250 - 100} = 67\% \quad [\text{Eq 17}]$$

Software that will calculate these configuration parameters is available on a diskette "HVAC Controls Calculations" from the TCX for HVAC Controls.*

Cooling Coil Control Loop

The standard cooling coil temperature control loop is a constant-temperature control loop and is shown in Figure 21. This loop operates similar to the standard preheat coil temperature control loop.

As shown in Figure 21, temperature-sensing element and transmitter TT sends a temperature signal to controller TC which modulates transducer IP. The pneumatic signal from IP is connected to positive positioner PP, which operates cooling coil valve VLV. The following conditions must exist for the control valve to open: the supply fan must be on, and the control system must be in the occupied mode as determined by the system time clock. Relay contact R between TC and IP is open when either condition is not met.

* U.S. Army Engineering District, Savannah, P.O. Box 889, Savannah, GA 31402-0889; tel. 912-652-5386.

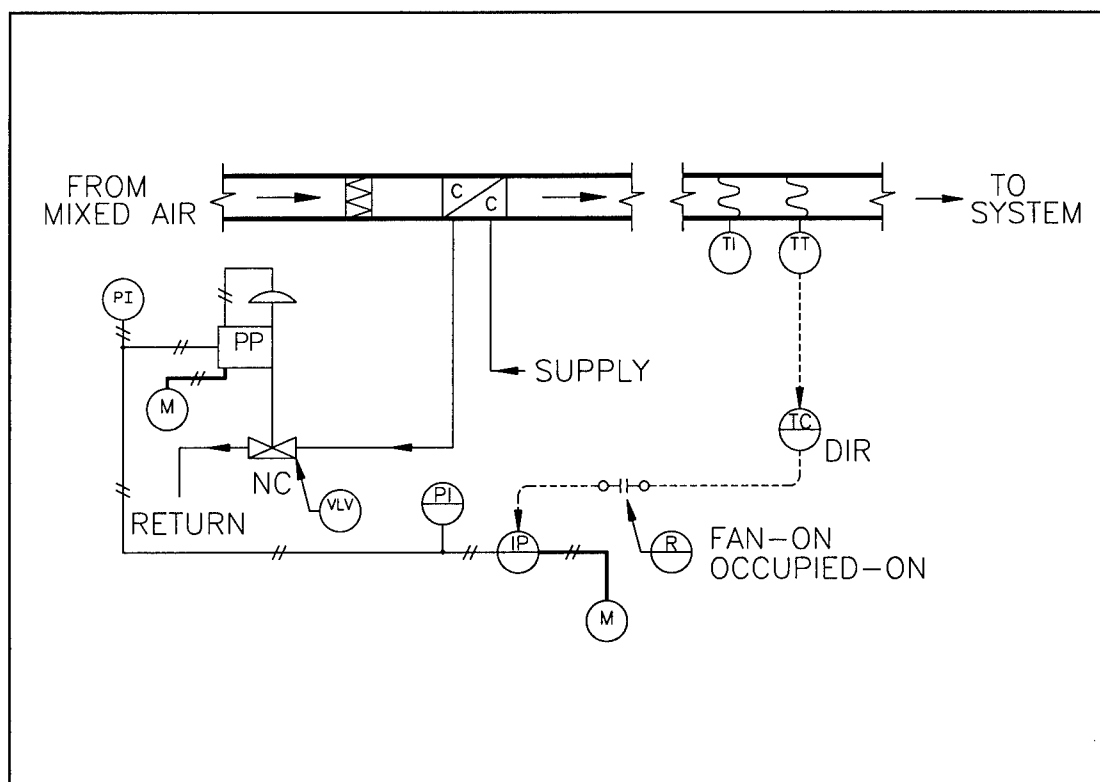

Figure 21. Cooling coil temperature control loop.

In this control loop, valve VLV is normally closed (NC) and fails in the fully closed position under the pressure of the valve actuator's return spring on a loss of electric signal, pneumatic signal, or positive positioner air supply.

Also shown in Figure 21 are the required manual temperature indicators TI (thermometers) and manual pressure indicators PI (pressure gauges), which should be installed in all control loops for diagnostic purposes.

Economizer/Mixed Air Loop

The use of up to 100 percent outdoor air for “free” cooling when the outdoor conditions are favorable is called an economizer cycle. With an economizer cycle, fresh outdoor air is used to cool in spring, fall, and winter, thus reducing the amount of chilled water needed. The amount of outside air used in the system is controlled by an economizer/mixed air control loop that measures indoor and outdoor conditions and controls the supply, return, and exhaust air dampers of the system accordingly.

Ideally, the control loop logic would use the enthalpies, or total heat contents, of the outside air and return air to decide the optimum amount of outside air to introduce into the system. However, enthalpy has proven to be difficult to measure reliably in HVAC systems as both the temperature and humidity of the air must be

accurately measured. Fortunately, computer simulations have shown that, for most locations of interest to the Army, an economizer cycle logic based on temperature measurement alone provides nearly the same amount of free cooling on an annual basis as an enthalpy-based logic. Thus, the standard economizer/mixed air temperature control loop to be used in Army applications is based on a comparison of the temperatures of the outside and return air streams.

The standard economizer/mixed air control loop is shown in Figure 22. The control hardware required to accomplish the economizer/mixed air control loop includes mixed air temperature controller TC to position the supply, return, and exhaust air dampers of the system; economizer controller EC to determine when free cooling can be used; minimum position switch MPS to set the minimum outside air quantity to be introduced when the system is in the occupied mode; and high signal selector TY to ensure that minimum outside air is introduced into the system as required. The actuators on the dampers operate like actuators on control valves. The outside air damper and relief air damper normally are closed and operate in parallel with each other. The return air damper is normally open and works opposite to the outside air and relief air dampers.

Economizer controller EC essentially operates as a switch that allows mixed air temperature controller TC to modulate the dampers to achieve free cooling when two

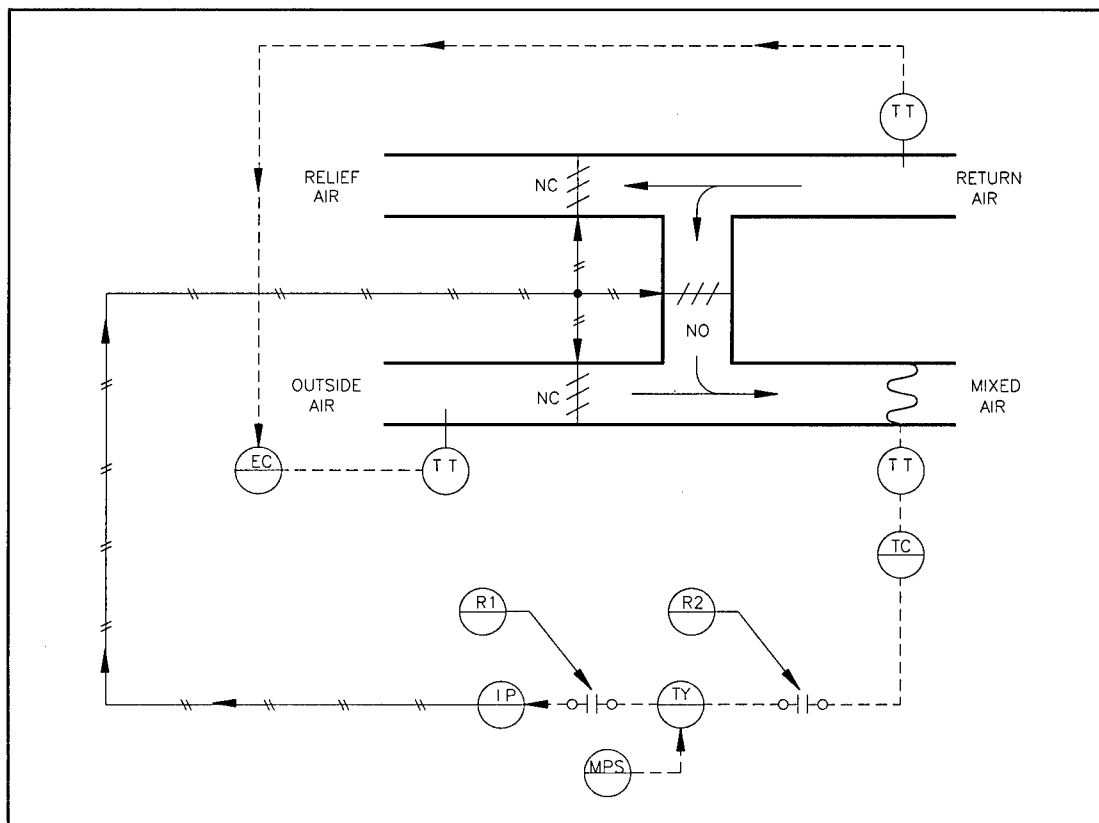

Figure 22. Economizer/mixed air temperature control loop.

conditions are satisfied. First, the return air temperature, as indicated by return air temperature-sensing element and transmitter TT, must indicate that the system is in the cooling mode. Second, the outside air temperature, as indicated by outside air temperature-sensing element and transmitter TT, must be sufficiently below the return air temperature to ensure that free cooling is possible.

Outside air is not used when the control system is in the unoccupied mode or in the ventilation delay mode. Normally open (NO) relay contact R1 in the circuit to IP keeps the outside air damper closed under these conditions and when the supply fan is off. When the system is in the minimum outside air mode as determined by EC, open relay contact R2 in the circuit between TC and high signal selector TY keeps the dampers open to the manual setting of minimum position switch MPS. When both of these relay contacts are closed, the control system is operating in the occupied mode and in the economizer mode. Mixed air temperature-sensing element and transmitter TT sends a signal to TC, which adjusts its output to modulate the dampers between their minimum outside air and full outside air positions. The signal from MPS or the signal from TC operates through high signal selector TY to operate IP, which sends a pneumatic signal to the damper actuators.

Economizer Process Variable (PV) and Deviation (DEV) Contact Setpoints. The economizer cycle is controlled based on a comparison of the return air and outside air dry bulb temperatures. For the economizer cycle to operate, there must be a cooling demand as indicated by the return air temperature. If the return air temperature is above about 73 °F, there is a probable demand for cooling (multizone systems are an exception and will be discussed later). In addition to a cooling demand, the outside air must be cool enough to supply free cooling. The economizer controller essentially operates as a switch to allow the mixed air temperature controller to modulate the system dampers when each of two conditions are satisfied:

The PV Contact Setpoint (Switching Condition 1). This switching condition is based on a measurement of the return air dry bulb temperature when the return air temperature is the process variable input to the economizer controller. Typically, the return air temperature is nearly the same as the space temperature. Space temperature is usually controlled from a space thermostat that has dual setpoints for heating and cooling. Typical thermostat setpoints are 68 °F for heating and 78 °F for cooling. The PV contact setpoint usually is selected to be at the mid point of these two extremes (73 °F). (The actual value selected is shown in the equipment schedule.) Therefore the economizer cycle will not operate when the return air temperature is below 73 °F. However, when the return air temperature exceeds

73 °F, the space is assumed to require cooling, and the economizer operates if the second condition also is satisfied.

Information included in the equipment schedule is the temperature at which the PV contact is closed and the temperature at which the PV contact is open. The midpoint between open and closed is the PV contact setpoint. The magnitude of the switching differential establishes the return air temperatures at which the contact is open and closed. Typically, a 2 °F switching differential is used; therefore, the equipment schedule indicates that the PV contact is closed when the return air temperature is 73 °F and open when the temperature is 71 °F.

Note that this control system is based on a significant difference between the heating season and the cooling season thermostat setpoints and that the switch-over temperature must be within this range. If the space thermostat setpoint is reset by the user to a value not consistent with the assumed range, the economizer controller PV contact setpoint may also need to be changed. If the user eliminates the dead-band by using the same or essentially the same setting for heating and cooling, the economizer cycle may not function as designed. A typical PV contact setpoint is 73 °F.

The PV Contact Setpoint for Multizone Systems Only (Switching Condition 1).

This switching condition is based on a measurement of the outside air dry bulb temperature when the outside air temperature is the PV input to the economizer controller. The outside air must be measured to provide an indication of the need for cooling because the return air temperature in a multizone system stays relatively constant year around. The PV contact setpoint for multizone systems is primarily a function of the internal loads (a higher load results in a lower PV contact setpoint) and, as a result, is best selected via computer simulation although typical values range from 50 to 60 °F.

The DEV Contact Setpoint (Switching Condition 2). The second condition that must be satisfied for economizer operation is based on a comparison between the return air and the outside air dry bulb temperatures. This difference between the outdoor and return air temperatures is the DEV contact setpoint of the economizer controller.

Information on the equipment schedule for switching condition 2 is the temperature difference at which the DEV contact is closed and the temperature at which the DEV contact is open. The midpoint between open and closed is the DEV contact setpoint. The magnitude of the switching differential establishes the open and closed temperatures. For example, with a 2 °F switching differential the DEV contact is

closed when the difference between the outdoor and return air is 8 °F and open when the difference is 6 °F. Typical DEV contact setpoints range from 0 to 10 °F.

Software that will calculate the deviation contact setpoint parameter is available on a diskette "HVAC Controls Calculations" from the TCX for HVAC Controls*.

Supply Duct Static Pressure Control Loop

In a variable air volume (VAV) system, temperature control is achieved by varying the amount of supply air delivered to the various zones based on each zone's individual needs. This system requires that the supply fan's output be modulated to maintain a constant static pressure in the supply duct. This pressure is required to ensure that the zone VAV terminal boxes will function properly. The two major methods of controlling the supply fan volume are the use of variable speed fan drives and inlet vane guides.

The standard supply duct static pressure control loop using inlet vane guides is shown in Figure 23. If "fan-on" relay R is energized, the output of static pressure controller PC is sent to transducer IP to control the positive positioner and actuator PP, which operates fan inlet vanes. Otherwise the inlet vanes are normally closed (unloading the fan).

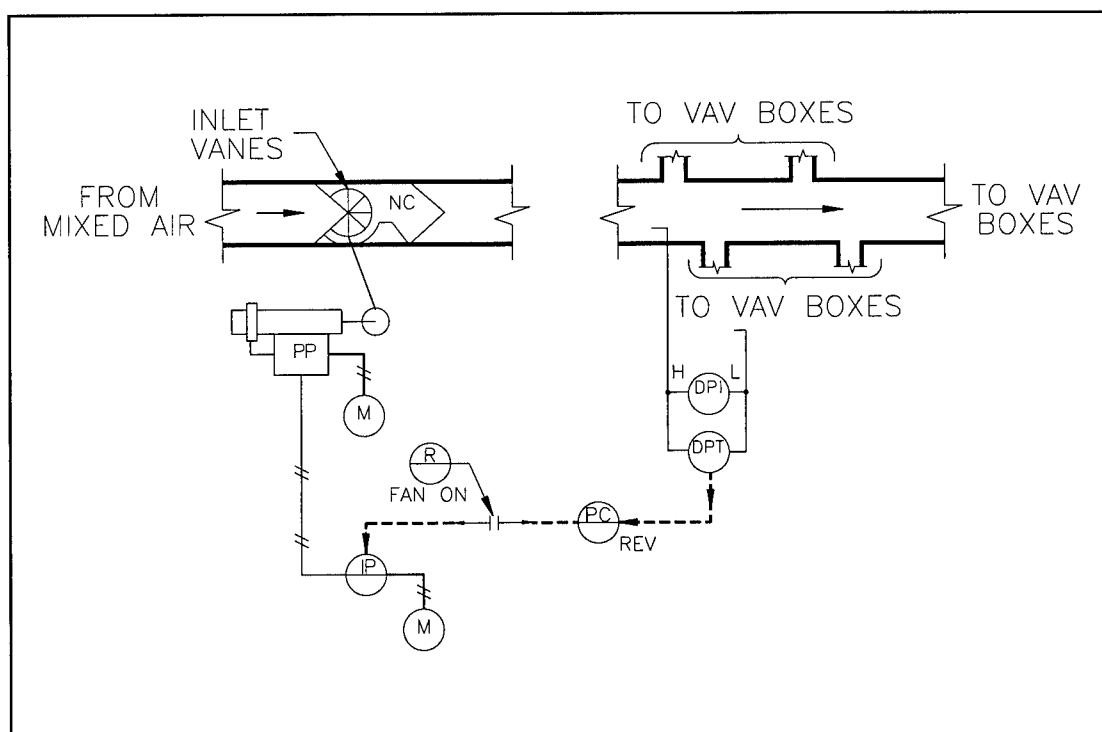

Figure 23. Supply duct static pressure control loop.

* U.S. Army Engineering District, Savannah, P.O. Box 889, Savannah, GA 31402-0889; tel. 912-652-5386.

Differential pressure transducer (DPT) must have a relatively low range, such as 0.0 to 2.0 in. of water column. The sensing location of DPT is approximately two-thirds of the distance from the supply fan along the duct calculated to have the greatest pressure drop.

Return Fan Control Loop

Some variable air volume systems include a return air fan. In these systems, the return air volume must be controlled to help ensure that there is adequate air distribution in the system.

The standard return fan volume control loop, referred to as flow matching, is shown in Figure 24. Flow-sensing elements and linearized transmitters (FT) in the supply air and return air ducts receive signals from duct-mounted airflow measurement stations and sensing arrays (AFMA). Both FTs send signals to return fan controller FC. These signals are the information needed to maintain a fixed volume differential (in cubic feet per minute [cfm]) between the supply air and return air fans. The return airflow signal enters FC as a process variable (PV) input. The supply airflow signal enters FC as a control point adjustment (CPA). FC then controls inlet vanes through transducer IP to maintain the flow in the return duct at an airflow rate less than that in the supply duct. If "fan-on" relay R is not energized, the normally closed inlet vanes remain closed.

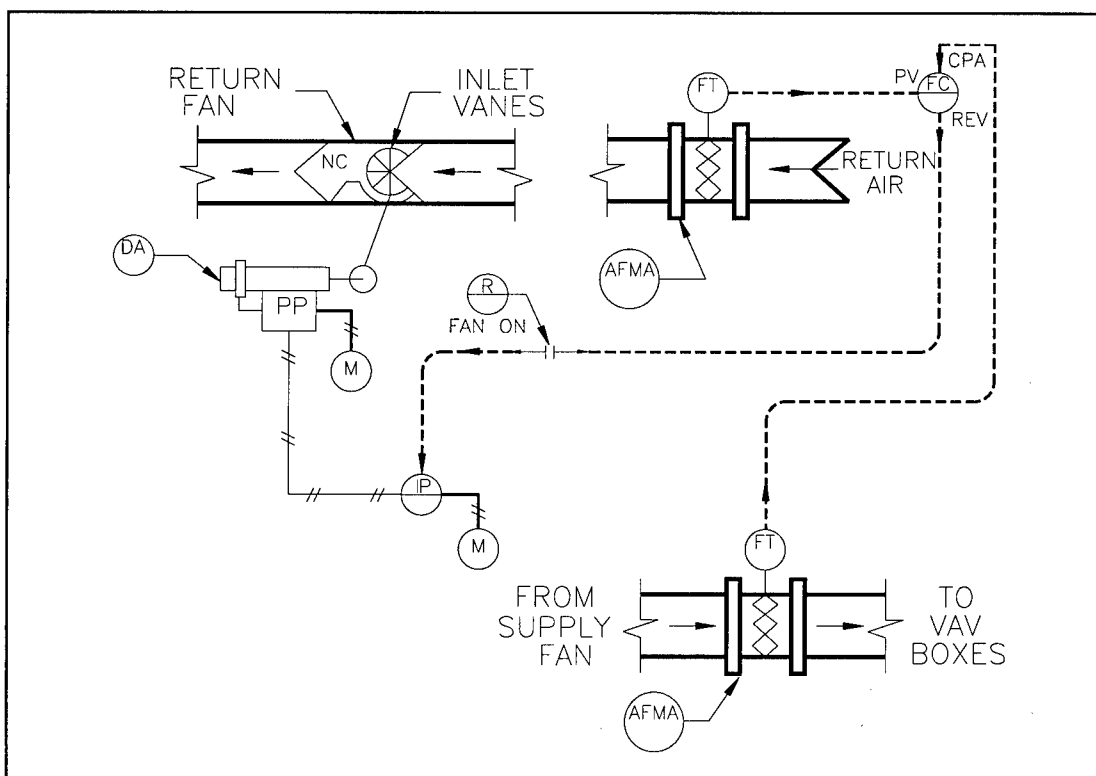

Figure 24. Return fan volume control loop.

In this standard control loop, the single-loop digital controller performs several critical functions. The signal from the supply airflow measuring station is a direct input to the CPA port (remote setpoint input) of the return fan controller. The first function performed by the controller is to scale the signal to the same cubic feet per minute range as the process variable input. To establish the appropriate setpoint signal, ratioing and biasing of this scaled signal is required. The ratio action compensates for differences in the supply and return duct cross-sectional areas and any differences in the spans of the supply and return airflow transmitters. The bias function subtracts a cubic feet per minute quantity from the ratioed signal to establish the constant flow differential requirement. Typically the differential flow quantity is set to be slightly greater than the building exhaust (cubic feet per minute), which provides for slight building pressurization.

As an example, consider a VAV system with a maximum supply airflow of 10,000 cfm. The building exhaust is known to be 2000 cfm. Thus the desired flow differential between the supply and return airflows is selected to be slightly more than this to provide for slight building pressurization (e.g., 2500 cfm). The supply and return air ducts have cross-sectional areas of 10 ft² and 20 ft², respectively. Flow transmitters with the appropriate feet per minute (fpm) spans must first be selected for both the return and supply airflow measuring stations. These stations measure flow velocity and not volume cubic feet per minute. The supply air transmitter range can be selected to be 4 mA at 0 fpm and 20 mA at 1200 fpm. These values represent a supply air volume of 0 cfm and 12,000 cfm, respectively. A flow transmitter can be selected for the return air side that has the same range. Note that a 20 mA signal corresponds to a velocity of 1200 fpm but the volume is 24,000 cfm because the area of the return air duct is 20 ft².

Based on the foregoing information, the ratio setting to be input into the controller can be calculated. The ratio is a dimensionless parameter defined by the mathematical expression:

$$\text{Ratio} = \frac{\text{Area}_s}{\text{Area}_r} \times \frac{\text{FPM}_s}{\text{FPM}_r} \quad [\text{Eq 18}]$$

where:

Area_s = cross-sectional area of the supply duct,

Area_r = cross-sectional area of the return duct,

FPM_s = supply airflow transmitter span,

FPM_r = return airflow transmitter span.

In the foregoing example, the ratio is:

$$\text{Ratio} = \left(\frac{10}{20}\right) \times \left(\frac{1200}{1200}\right) = 0.5 \quad [\text{Eq 19}]$$

The desired bias can be entered directly into the controller. In the example, the bias configuration parameter is -2500 cfm. This value is the difference in volumetric flow the controller will maintain between the supply and return ducts.

The effects of scaling (to a range of 0 to 12,000 cfm), ratioing (by 0.5), and biasing (the flow difference to -2500 cfm) are illustrated in Table 2 in response to various supply duct flow conditions. Note that the biased CPA, which is the resulting setpoint of the controller, is a constant 2500 cfm less than the supply actual flow cubic feet per minute.

Humidity Control Loop

Although humidity control is not always required in an HVAC system, it is usually provided for by a humidifier when needed. Steam humidifiers are often used because of their simplicity. The humidity controller is set at the desired relative humidity setpoint. A change in relative humidity from setpoint causes a control signal to be sent to the controlled device. For example, a humidity controller in a building sensing a decrease in relative humidity to a point below the setpoint responds by sending a control signal to a steam valve at the inlet to a duct-mounted humidifier unit. The steam valve is opened to admit steam and raise the space

Table 2. Return fan controller ratio and bias example.

| Supply Duct | | Return Fan Controller | | | |
|-------------------|-------------------|-----------------------|------------------|-------------------|------------------|
| Sensed Flow (fpm) | Actual Flow (cfm) | RSP Input (mA) | Scaled CPA (cfm) | Ratioed CPA (cfm) | Biased CPA (cfm) |
| 0 | 0 | 4.0 | 0 | 0 | 0 |
| 240 | 2400 | 7.2 | 4800 | 2400 | 0 |
| 500 | 5000 | 10.7 | 10,000 | 5000 | 2500 |
| 600 | 6000 | 12.0 | 12,000 | 6000 | 3500 |
| 840 | 8400 | 15.2 | 16,800 | 8400 | 5900 |
| 1000 | 10,000 | 17.3 | 20,000 | 10,000 | 7500 |
| 1200 | 12,000 | 20.0 | 24,000 | 12,000 | 9500 |

fpm = feet per minute cfm = cubic feet per minute
 rsp = remote setpoint CPA = control point adjustment
 mA = milliamps

relative humidity. A high-limit humidity safety controller is located in the air-stream leaving the humidifier. As the humidity approaches the saturation point, the high-limit humidity controller overrides the space humidity controller by closing the steam valve to decrease supply air humidity in the duct and prevent water carryover from the humidifier.

The standard steam humidifier control loop is shown in Figure 25. The humidifier control valve VLV is normally closed. It is prevented from opening by normally open relay R unless: the fan is on, the system is in the occupied mode, and the ventilation delay period has expired. When these three conditions are met, relay R is closed so the humidity control system is operational. The output signal from the space relative humidity sensing element and transmitter (RHT) is received by its relative humidity controller RHC and compared to its setpoint. Likewise, the output signal from the duct RHT is received by high-limit relative humidity controller RHC and is compared to its setpoint. Both RHCs are reverse-acting controllers so, as their inputs increase, their outputs decrease. Low signal selector RHY selects the lower of the two signals from the RHCs and transmits it to IP whose pneumatic output signal controls the steam valve through positive positioner (PP).

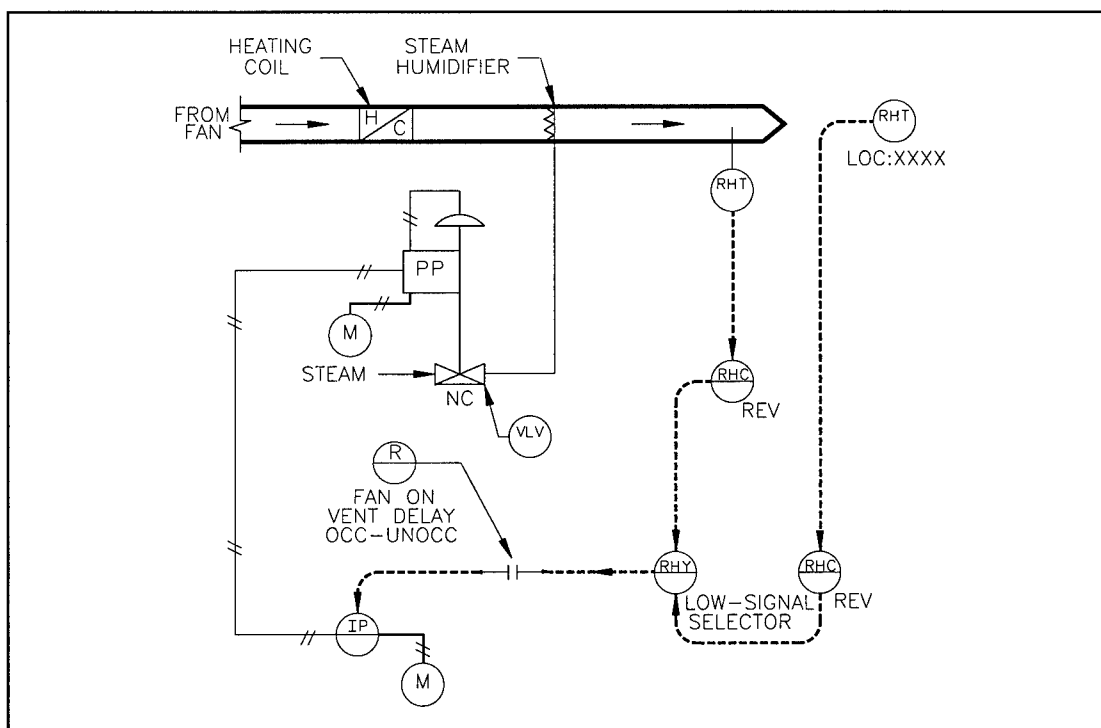

Figure 25. Humidity control loop.

5 Operation and Maintenance Documentation

CEGS-15950 requires the contractor to provide O&M documentation for the installed system. The O&M documentation should include:

- Step-by-step procedures required for each HVAC control system's start-up, operation, and shutdown. This requirement is usually met by providing the system sequence of operation, which should be identical or similar to that found in CEGS-15950 or TM 5-815-3.
- All detail drawings specific to the HVAC control system and installed equipment.
- Configuration checksheet for each controller, which shows the configuration parameters for each digital controller.
- Manufacturer supplied operation manuals including the controller operation manuals and time clock manual.
- Equipment data, which should indicate for each control device: the unique identifier, manufacturer name, and part number.
- Maintenance procedures for each control device and piece of control equipment. These procedures should consist of the manufacturer's installation and calibration data.
- Maintenance checklist for each HVAC control system.
- Recommended repair methods, either field repair, factory repair, or whole-item replacement.
- Spare parts data and recommended maintenance tool kits for all control devices.

Additional, useful contractor supplied O&M documentation might consist of the PVT report and the commissioning report. These documents are generated by the contractor and submitted to the government as part of system installation and commissioning. They provide a benchmark of system performance. The contractor-generated commissioning procedures are another useful piece of system documentation that details the commissioning/set-up of individual control loops and devices. These procedures may prove useful if a control device must be replaced by the O&M staff. Questions about O&M documentation can be directed to the Area Office.

6 Operation

Standard Control Panel

Operation of the standard control systems requires familiarity with the standard control panel. The standard panel evolved out of the need for simple, accurate, and reliable controls. Although there are more than 20 standard control systems, they all are based on the same standard control panel design, with only slight differences between panels for the different applications. This similarity should significantly reduce the time and effort required to learn, understand, and operate different HVAC control systems.

The control system documentation also is standardized. Contract requirements, based on CEGS-15950 and TM 5-815-3, are specific about the documents to be provided by the contractor for each HVAC control system. This chapter describes the operation of a typical control system based on the contractor-provided documentation referred to as the Posted Instructions.

This chapter provides a detailed description of a typical HVAC control system Posted Instructions, the "Heating and Ventilating Control System" from TM 5-815-3. Because of the similarity between systems, this description will provide significant insight into the operation of any other standard control systems in TM 5-815-3.

Posted Instructions

Posted Instructions describing the control system and the control panel are required to be posted by the contractor in the mechanical room. They consist of printed "instructions" and half-sized, plastic, laminated "drawings." Understanding the Posted Instructions is critical to proper system operation, and they are a useful tool in performing system maintenance. The Posted Instructions include:

- control sequence
- control schematic
- ladder diagram
- control panel drawings

- wiring diagrams
- single-loop digital controller operators' manual(s)
- controller configuration checksheets
- commissioning procedures
- preventive maintenance instructions
- valve and damper schedules.

Control Sequence

The control sequence is a written description of the operating modes and control functions of the HVAC control system; it is intended to provide a clear and accurate description of the control schematic and the ladder diagram. The control sequence may be printed on 8 1/2 by 11 in. sheets of paper or may be included on the half-size control drawings.

Control Schematic

The control schematic is a functional diagram that shows the basic layout of the HVAC system, including the interconnection of the various control devices. The control schematic also consists of an equipment schedule and in some cases a sequencing chart. Each of these are described in detail in this section. The typical control schematic, shown in Figure 26, is for a heating and ventilating control system.

In the mixed air section, the air dampers controlling the quantity and path of airflow are identified as AD XX-01, AD XX-02, and AD XX-03. These dampers are actuated by pneumatic damper actuators DA XX-01, DA XX-02, and DA XX-03, respectively. The deenergized position of each damper is indicated next to the damper symbol as NO (normally open) or NC (normally closed).

Each damper actuator is required to have a positive positioner, which is indicated by PP. A positive positioner receives a pneumatic input control signal and is supplied with air from the main air source as indicated by M. Both main air and pneumatic control signal air lines are represented by solid lines with double slashes. The pneumatic signal transmitted to the controlled devices (damper actuators in this case) can be field-monitored by pressure gauges, PI (pressure indicator).

The pneumatic control signal line to DA XX-01, DA XX-02, and DA XX-03 can be traced back to its source, a current-to-pneumatic transducer labelled IP XX-01. This device converts the 4 to 20 mA current control signal into a proportional pneumatic

signal. Note that the IP is supplied with main air. Electrical control signal lines, such as the 4 to 20 mA signal line, are indicated by a dashed line.

A normally open relay contact, R XX-02, is in series with the control signal line. The number 3 below the contact indicates on which line of the ladder diagram the relay appears.

TY XX-01 represents a high signal selector function module. One of the inputs to the high signal selector is from the minimum position switch, MPS XX-01. As its name implies, the minimum position switch provides an output signal that establishes the minimum position of the outside air damper regardless of the control signal. The output of the minimum position switch is manually adjusted. The other input to the high signal selector is from the temperature controller, TC XX-01.

The TC XX-01 receives 4 to 20 mA current signals from two sources. A space temperature signal (from temperature transmitter TT XX-01) enters the PV input. The other input to the controller is the CPA, which is from temperature setpoint device TSP XX-01. This device produces a 4 to 20 mA current output and is manually adjusted to change the temperature controller's setpoint via a dial on the TSP device, which is calibrated in degrees. The temperature controller receives these two inputs and produces an output signal that controls the mixing dampers and the heating control valve. The DIR, next to the controller symbol, identifies the unit as direct-acting (i.e., when the PV signal increases, the controller's output signal increases).

The output signal from the temperature controller is also sent to IP XX-02 where it is converted to a pneumatic signal used to control the heating valve. This pneumatic signal is displayed on a panel-mounted pressure gauge, PI XX-02, and at the field-mounted pressure gauge, PI. Positive positioner, PP, receives the pneumatic signal and positions the heating water control valve, VLV XX-01, through its actuator. The drawing identifies the heating water control valve as being normally open (NO).

This completes discussion of the temperature control portion of the control system schematic. However, several other items need to be addressed, including smoke detector SMK XX-02, which is located in the return air duct. The number next to the device indicates where to look on the ladder diagram for the device's contact. Next to the smoke detector is a thermometer, TI XX-03, which gives a local display of return air temperature. Outside air temperature, TI XX-01, and mixed air thermometer, TI XX-02 are located upstream of the heating coil.

The system's air filter is identified by the hexagonal symbol, FLTR. The pressure drop across the filter is monitored by a two-position differential pressure switch, DPS XX-01, whose contact is located on line 7 of the ladder diagram. The actual pressure drop across the filter can be field monitored by differential pressure indicator DPI XX-01. The ports for these two devices, H and L, represent high and low pressure, respectively.

Upstream of the heating coil is low-temperature sensor, TSL XX-01, commonly referred to as a freezestat. The low-temperature sensor contact(s) are located on lines 8 and 101 of the ladder diagram. The heating coil (HC) is upstream of the supply fan (SF). Downstream of the supply fan is another smoke detector (SMK XX-01). The temperature of the supply air is measured by thermometer TI XX-04, downstream of the supply fan.

Sequencing schedules, as shown in Figure 27, are considered to be part of the control schematic. These schedules show the relationship between space temperature and the positions of the controlled devices. The sequencing schedule on the left shows device sequencing when the control system is operating in the ventilation delay mode. The sequencing schedule on the right shows device sequencing when the control system is in the occupied mode. Additional information shown in the sequencing schedules includes the relationship between space temperature ($^{\circ}\text{F}$

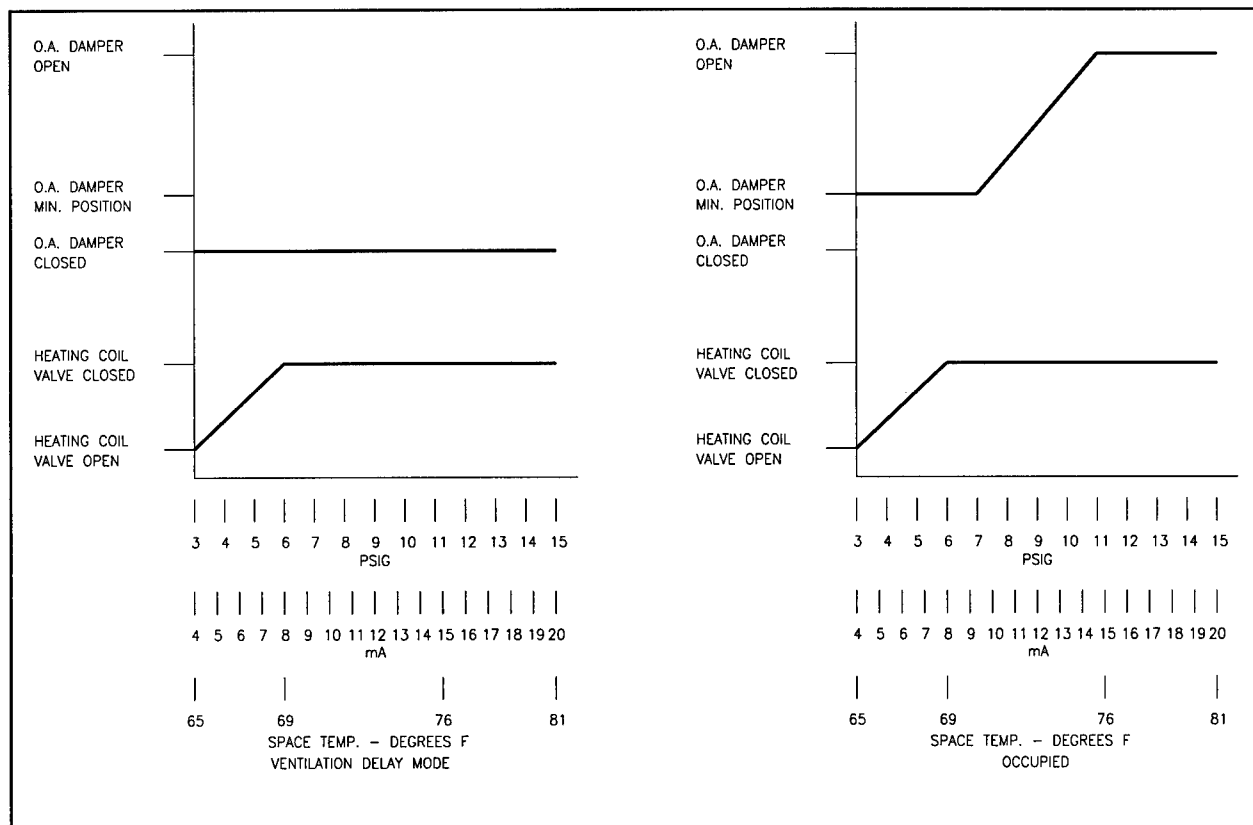

Figure 27. Typical sequencing schedule.

sensed by controller TC XX-01) and the controller output signal in milliamps. Also shown is the relationship between the controller (TC XX-01) output signal in milliamps (mA) and the current to pneumatic transducer (IP XX-01 and IP XX-02) output signals in units of pounds per square inch gage.

The only remaining device affecting the control of the space temperature is the night setback thermostat (TSL XX-02) located within the space and shown next to TT XX-01. This thermostat cycles the fan on and off during unoccupied hours to ensure that the space temperature does not fall below some minimum value. The 104 below the night thermostat indicates the line number of the ladder diagram on which the night thermostat's contact appears.

The equipment schedule in Figure 28 is an important part of the control schematic. The equipment schedule lists the various control loops and, for each loop, indicates each control device according to its function. Important operational parameters for each device are shown, including: setpoint, range, and additional parameters. These parameters are selected by the designer and set-up initially during installation and commissioning of the control system.

Ladder Diagram

The ladder diagram is used to indicate the operating sequence and control modes of the system's various control devices, safeties, and interlocks. The ladder diagrams

| LOOP CONTROL FUNCTION | DEVICE NUMBER | DEVICE FUNCTION | SETPOINT | RANGE | ADDITIONAL PARAMETERS |
|---------------------------|----------------------------------|--|-------------------------------------|---|--|
| SPACE TEMPERATURE | DA-XX-01 DA-XX-02 DA-XX-03 | DAMPER ACTUATOR | — | 7-11 PSIG | — |
| | MPS-XX-01 | MINIMUM POSITION SWITCH | — | — | SET MINIMUM OA CFM EQUAL TO XXXX CFM |
| | TSL-XX-01 | FREZESTAT | 35 DEG F | — | — |
| | VLV-XX-01 | HEATING COIL VALVE | — | 3-6 PSIG | Cv = __ CLOSE AGAINST __ PSIG |
| | TC-XX-01 | SPACE TEMPERATURE CONTROLLER | 68 DEG F | 50 TO 85 DEG F | SET LIMITS AVAILABLE TO OCCUPANT BY TSP-XX-01 AT 66 - 72 DEG F |
| | TT-XX-01 | SPACE TEMPERATURE TRANSMITTER | — | 50 TO 85 DEG F | — |
| | TSP-XX-01 | REMOTE SETPOINT ADJUSTMENT | 4 mA = 50 DEG F 20 mA = 85 DEG F | — | — |
| SPACE LOW TEMPERATURE | TSL-XX-02 | NIGHT STAT - SPACE LOW TEMPERATURE PROTECTION | 55 DEG F | 5 DEG F DIFFERENTIAL | — |
| OCCUPIED MODE | CLK-XX-01 CONTACT | 365 DAY SCHEDULE | — | NORMAL SCHEDULE CLOSED: 0705 HRS, OPEN: 1700 HRS M,T,W,Th,F | OPEN: SAT, SUN AND HOLIDAYS |
| VENTILATION DELAY MODE | CLK-XX-01 CONTACT | 365 DAY SCHEDULE | — | NORMAL SCHEDULE CLOSED: 0700 HRS, OPEN: 0800 HRS M,T,W,Th,F | ↓ |

NOTE: OTHER CONTROL DEVICES SUCH AS I/Ps, RELAYS, SIGNAL SELECTERS AND TERMINAL UNIT CONTROLLERS ARE NOT SHOWN.

Figure 28. Typical equipment schedule.

shown in Figures 29 and 30 are for the heating and ventilating control system from TM 5-815-3. The ladder diagram in Figure 29 describes the control circuit logic contained within the system control panel. The ladder diagram in Figure 30 shows the circuit logic contained in the supply fan starter circuit.

Both ladder diagrams consist of two vertical lines on the left- and right-hand sides connected by parallel horizontal lines or circuit paths. The vertical lines, or legs, are at different voltage levels. In Figure 29, the left-hand leg is labelled H (hot) and the right-hand leg is labelled N (neutral). The voltage difference between the hot and neutral legs is 120 VAC because the power source for this portion of the control system is 120 VAC line voltage. In the supply fan starter circuit (Figure 30), the vertical legs are split near the top and the upper portions of these legs are connected to L1 and L2. L1 and L2 may represent the hot and neutral legs of a high-voltage, single-phase source (such as 220, 277, or 480 VAC single-phase circuits), or they may represent any two legs of a high-voltage, three-phase electrical system. In either case, because such voltages are too high to be safely used in control circuits, they are reduced by transformer XMFR to a safer voltage level, typically 120 VAC. The hot and neutral legs of the low voltage portion of this control circuit are labelled X1 and X2.

The ladder diagram includes horizontal lines (or circuit paths) connecting the hot and neutral legs. These horizontal lines are numbered along the left side. In Figure 29, the lines are numbered from 0 through 15, and in Figure 30 they are numbered 100 through 104.

On line 0 is time clock CLK XX-01. The time clock performs two separately timed functions. One of its functions is to schedule the beginning and end of the occupied and unoccupied modes. Its other function is to schedule the start and stop of the vent-delay mode. The 1 below the clock symbol indicates that the time clock's Occ-Unocc relay controls a contact on line 1. The 5 indicates that the time clock's vent-delay relay controls a contact on line 5.

On the left side of line 1 is shown the time clock's normally open Occ-Unocc contact. The 0 below the contact indicates that the device which controls this contact is on line 0 (in this case, the time clock). If an EMCS system is in use, then the EMCS system can override the time clock by making a parallel connection at the two indicated terminals. The next device on line 1 is the manually operated auto override switch (HS XX-01) located in the control panel that allows local override of the time clock. When the system is put into operation by the time clock, the auto override switch, or EMCS, a circuit path is completed from the hot leg to the neutral leg through relay R XX-01. Relay R XX-01 is energized, which closes the normally

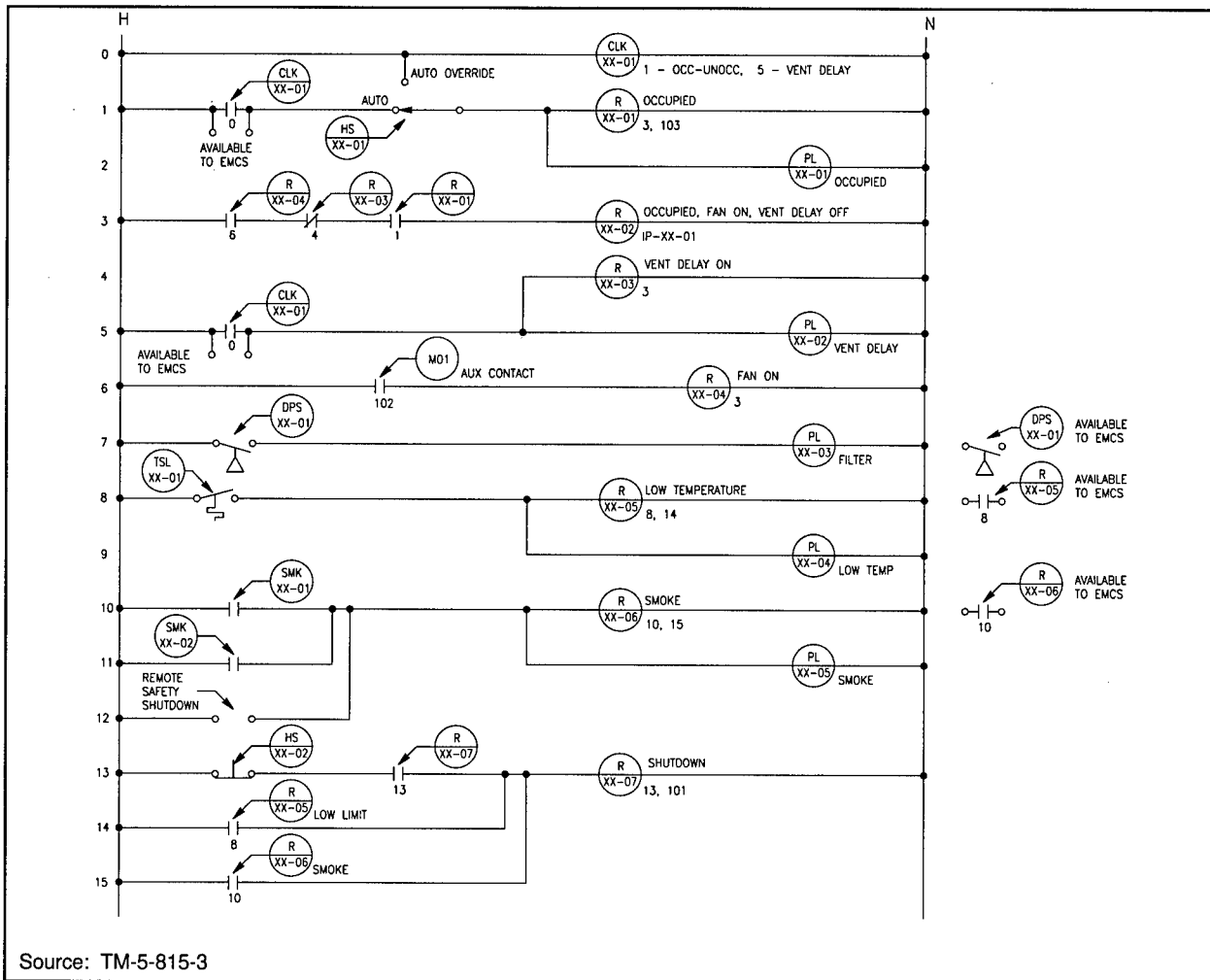

Figure 29. Control system ladder diagram.

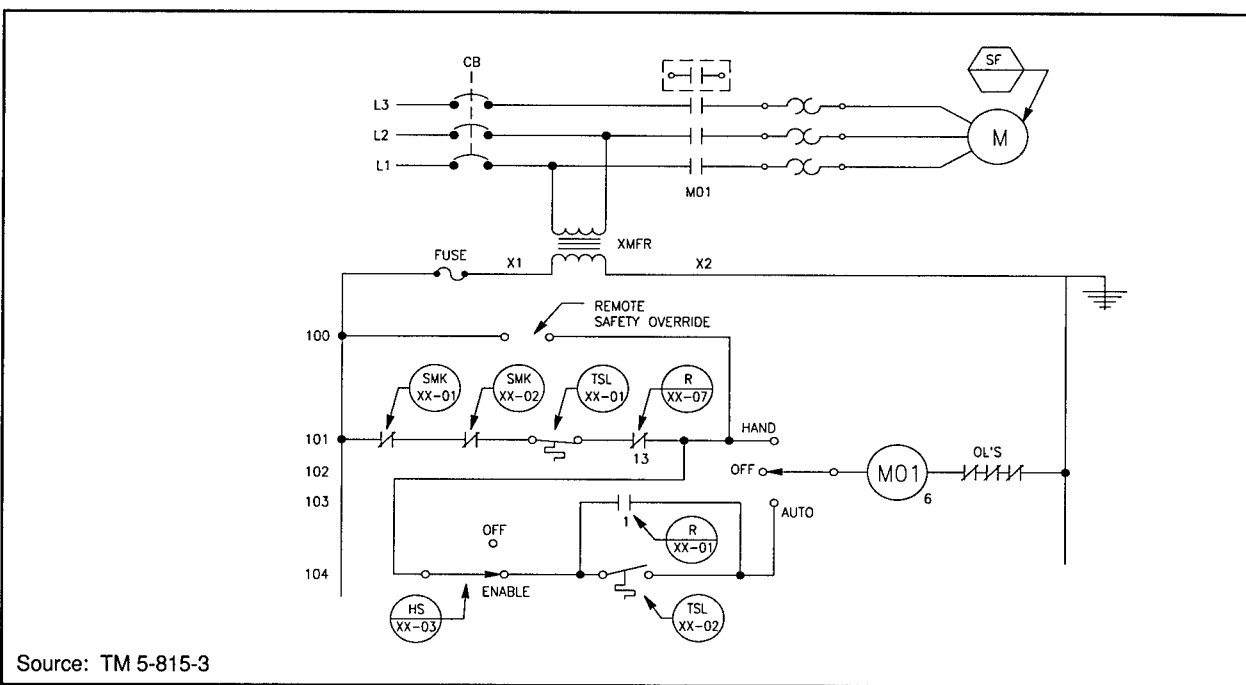

Figure 30. Control system fan starter circuit ladder diagram.

open contacts on lines 3 and 103. When a circuit is completed through relay R XX-01, a parallel circuit is simultaneously completed through pilot light PL XX-01, which is shown on line 2. As noted, this pilot light is located in the control panel and lights when the system is in the occupied mode.

Line 3 shows that the normally open contact of R XX-01 is in series with two other contacts, one normally open and the other normally closed. All three contacts must be closed to complete a circuit path from the hot leg to the neutral leg through relay R XX-02. The normally closed contact is referenced to relay R XX-03 on line 4. This relay is energized by either the time clock's normally open vent-delay contact or an EMCS contact on line 5. Assuming the system is controlled locally and not through EMCS, the normally open contact on line 5 is open, except when the system is in its vent-delay mode. During the vent-delay mode, relay R XX-03 is energized, which opens the normally closed contact on line 3. In addition, panel-mounted pilot light PL XX-02 on the right side of line 5 is lit, indicating that the system is in the vent-delay mode.

Assuming that the system is in the occupied mode and not in the vent-delay mode, the normally open contact (R XX-01, referenced to line 1) and the normally closed contact (R XX-03, referenced to line 4) on line 3 are closed. However, another normally open contact (R XX-04, referenced to line 6) must be closed to complete the circuit path to energize relay R XX-02. On line 6, relay R XX-04 is energized when a circuit path is completed through the normally open contact referenced to MO1 on line 102. MO1 refers to an auxiliary contact on the system's fan motor starter. When the fan motor is running, this normally open auxiliary contact is closed.

There is a manual switch on line 102 immediately to the left of fan starter coil MO1. This HOA (hand-off-auto) switch is in the "auto" position for normal operation. Assuming the HOA switch is set to the "auto" position, a circuit path could be completed either through the normally open relay contact (R XX-01) on line 103 or night thermostat TSL XX-02 on line 104. Referring again to R XX-01 on line 1, recall that the contact on line 103 closes when R XX-01 is energized (i.e., when the system is in the occupied mode). Continuing to follow the circuit path backward toward the hot leg, the path passes through HS XX-03, a hand switch that allows the system to be enabled or disabled. Assuming that this switch is closed (i.e., enabled), the circuit path can be traced back to line 101. At line 101, the path must pass through three normally closed contacts and freezestat TSL XX-01. Therefore, at mixed air temperatures that pose no risk of freezing system coils (typically, above about 45 °F), freezestat TSL XX-01's contact will be closed. Assuming, for the moment, that the contacts associated with SMK XX-01, SMK XX-02, and R XX-07 are closed, the supply fan's motor starter coil, MO1, is energized and the fan is

started. This closes the auxiliary contact on line 6, which energizes relay R XX-04 and closes its contact on line 3. This energizes relay R XX-02, which closes a contact ahead of IP XX-01, as shown in Figure 29, which allows the system to control its outside air, return air, and relief air dampers. As noted next to relay R XX-02, this relay is energized when the system is in the occupied mode, the vent-delay mode is off, and the supply fan is running.

Differential pressure switch DPS XX-01 on line 7 closes when it senses a high differential pressure across the system's filters. When it closes, panel-mounted pilot light PL XX-03 illuminates to indicate that the filters are dirty.

On line 8, when the mixed air temperature is above the risk of freezing the system coil (above about 45 °F), the contact of freezestat TSL XX-01 is open. With TSL XX-01 contact open, relay R XX-05 is deenergized and panel-mounted low temperature pilot light PL XX-04 shown on line 9 is off. If the mixed air temperature falls below the setpoint of freezestat TSL XX-01, the device contacts close. With TSL XX-01 contacts closed, relay R XX-05 is energized; this closes a normally open contact on line 14, which initiates shutdown of the system to prevent freezing the coil.

Before describing the system shutdown sequence in detail, note that the shutdown procedure can be initiated in more than one way. Line 15 is a circuit path in parallel with line 14. Shutdown is initiated if either relay R XX-05 or relay R XX-06 is energized, closing their associated, normally open contacts. Low mixed air temperature has already been shown to close the contact on line 14. The normally open contact on line 15 is referenced to smoke relay R XX-06 on line 10. Relay R XX-06 on line 10 can be energized by any of three parallel paths: through a normally open contact (on line 10) from smoke detector SMK XX-01, through a normally open contact (on line 11) from smoke detector SMK XX-02, or through an optional remote safety shutdown switch (i.e., a contact closure from a fire control system) on line 12. If either of the smoke detectors is activated or if the remote safety shutdown switch is closed, relay R XX-06 is energized and the panel-mounted smoke pilot light on line 11 is illuminated. Also, the normally open contact associated with relay R XX-06 on line 15 is closed, initiating system shutdown.

Regardless of which circuit path (line 14 or line 15) is used to initiate a system shutdown, after relay R XX-07 is energized, it is locked in by closing its own normally open contact on line 13. This maintains the shutdown mode even if the alarm condition that caused the closure of the contacts on either line 14 (low mixed air temperature) or line 15 (smoke) is cleared. Freezestats and smoke detectors must be manually reset to clear the alarm condition. After the tripped alarm device

is reset, panel-mounted reset switch HS XX-02 (on line 13) must be pressed (opened) to break the circuit path to shutdown relay R XX-07. This resets the control panel.

The shutdown sequence immediately stops the system's supply fan. On line 101, the smoke detectors SMK XX-01 and SMK XX-02 and freezestat TSL XX-01 are all in a series so any one of them can break the current path to the fan motor's starting coil. As explained earlier, when any of these alarms occur, relay R XX-07 is energized, which opens its normally closed contact on line 101. Resetting the tripped alarm device is insufficient to restart the system. After resetting the tripped device, the panel-mounted reset button must be pressed to deenergize relay R XX-07 and close its normally closed contact on line 101.

For completeness, the supply fan also can be shut down in other ways. The circuit path through fan motor starter coil MO1 can be broken if any of the three normally closed contacts located on line 102 to the right of MO1 are opened. These are overload relay contacts that open when the motor current becomes high enough to risk damage to the fan motor. Also, the fan motor will shut down if the voltage supplied to the motor control circuit is interrupted, this will occur if circuit breaker CB on the primary (high-voltage) side of transformer XMFR is opened or if the fuse on the secondary (low-voltage) side of transformer XMFR is blown.

The supply fan can be operated despite the presence of shutdown alarm conditions. On line 100, terminals are shown for an optional remote safety override switch. If this manual switch is provided, it can be closed to bypass any open alarm contacts and allow the fan motor to run, assuming that the rest of the circuit path through MO1 is completed. If the time clock is not calling for the system to operate and the night thermostat is not in its low-temperature condition (i.e., closed) the fan motor still could be started by switching the HOA switch to the hand position. Therefore, there are several ways of bypassing or "defeating" the system's safety alarm devices. This should only be done by a person who understands how the system functions and the possible consequences of starting the system under such alarm conditions.

A brief discussion of three devices shown to the right of the ladder diagram in Figure 29 is warranted. These devices, DPS XX-01, R XX-05, and R XX-06 are labelled as available to EMCS. These devices can be used to provide output information to an EMCS. Differential pressure switch DPS XX-01 provides a contact closure output to EMCS to indicate the need to replace the system filters. Similar contacts are available from the normally open contacts of relays R XX-05 and R XX-06 to inform EMCS of low temperature and smoke alarm conditions. Note that the 8 next to the symbol for relay R XX-05 on the ladder diagram indicates that relay R XX-05's normally open contact is available as a contact closure output to EMCS. A 10 is

shown next to the symbol for relay R XX-06 to indicate that this relay's normally open contact also is available as an output to EMCS.

Control Panel Drawings

Control panel drawings consist of a series of drawings that show the arrangement of the control devices inside the control panel, the panel dimensions, and the terminal block layout (for electrical connections).

The Control Panel Drawing—Inner Door. Figure 31 shows the push buttons (or hand-switches) and pilot lights across the top of the inner door, the locations of the single-loop digital controllers, and the panel-mounted pressure gages. The standard control panel can accommodate up to six single-loop digital controllers, as shown in the inner door panel drawing (Figure 30). The number of controllers in the panel depends on the application. The dimensions of the standard panel cutout for mounting a digital controller is 3.62 by 3.62 in. The function and operation of the controller is described in detail in Chapter 7 of this manual.

The panel-mounted pressure gages are used to indicate the pneumatic pressure signal sent to the actuated control devices. The typical pressure range indicated is by each gage and is from 3 to 15 psi. When the digital controller output is 0 percent, its corresponding pressure gage should indicate 3 psi. When the digital controller output is 100 percent, its corresponding pressure gage should indicate 15 psi. The pressure gage located furthest to the right is the main air pressure gage and should always indicate a pressure within a range of 18 to 25 psi.

Although the push buttons and pilot lights described here are specific to the heating and ventilating control system, the majority of these push buttons and pilot lights are used in an identical manner in all the standard control panels. As illustrated in Figure 31, these include:

- **Reset.** This is a momentary contact switch that makes contact when pushed, but it returns to its original position when released. It is indicated as hand switch (HS XX-02) on line 13 of the ladder diagram in Figure 29 and is used to reset the control (to turn the system fan back on) following a low temperature (freezestat) alarm or smoke alarm.
- **Auto/auto override.** This two-position switch is given as hand switch (HS XX-01) on line 1 of the ladder diagram shown in Figure 29. When it is pushed, the upper half of the switch illuminates to indicate that the panel is in the auto mode (the occupied/unoccupied modes are under control of either the time clock or EMCS). When the switch is pushed again, the lower half of the switch

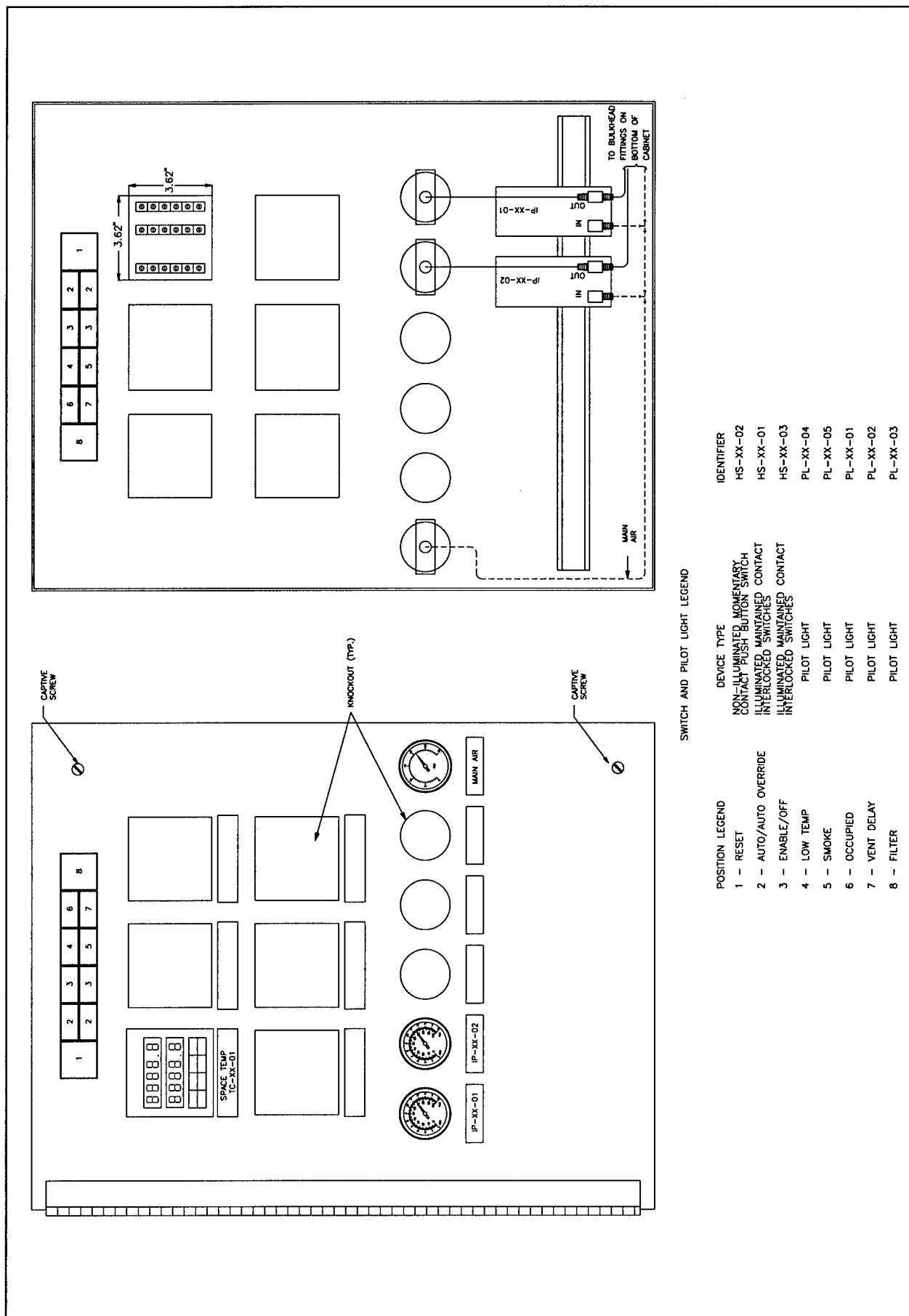

Figure 31. Standard control panel inner door—front and back views.

illuminates to indicate that the panel is in the auto override mode (in this condition the operator has manually placed the control panel in occupied mode).

- **Enable/off.** This two-position switch is given as hand switch (HS XX-03) on line 104 of the ladder diagram shown in Figure 30. When it is pushed, the upper half of the switch illuminates to indicate that the fan is enabled, or permitted, to energize the fan motor starter. When the switch is pushed again, the lower half of the switch illuminates to indicate that the panel is off, or not permitted, to energize the fan motor starter.
- **Low temp.** This pilot light is shown on line 9 of the ladder diagram in Figure 29; it illuminates when there is a low temperature condition in the duct (when the freezestat trips). The pilot light is turned off by removing the alarm condition (allowing the duct temperature to warm), manually resetting the freezestat at the location of the freezestat, then pushing the control panel reset button (described earlier).
- **Smoke.** This pilot light is shown on line 11 of the ladder diagram in Figure 29; it illuminates when there is smoke detected in either the supply or return air ducts (when the smoke detector(s) trip). The pilot light is turned off by removing the alarm condition (clearing the duct of smoke) then pushing the control panel reset button (described earlier).
- **Filter.** This pilot light is shown on line 7 of the ladder diagram in Figure 29; it illuminates when the differential pressure switch, installed across the air filter, detects a large pressure drop indicative of a dirty filter. The pilot light is turned off by replacing the dirty filter.
- **OCC.** This pilot light is indicated on line 2 of the ladder diagram in Figure 29; it illuminates when the control panel is in the occupied control mode as described by the control system sequence of operation and indicated in the ladder diagram logic.
- **Vent delay.** This pilot light is indicated on line 5 of the ladder diagram in Figure 29; it illuminates when the control panel is in the ventilation delay control mode as described by the control system sequence of operation and indicated in the ladder diagram logic. The system will be in the occupied mode and the system fan(s) will be on, but the outside and relief air dampers will remain closed until the ventilation delay mode expires.

The Control Panel Drawing—Back Panel. Figure 32 shows the back of the inside of the control panel. Across the top of the back panel are each of the control relays that were described in the ladder diagram section of this manual. Below the relays are three rows of terminal blocks (which are described in the next paragraph). Along the bottom of the back panel are other control devices, including the high signal selector (TY XX-01), minimum position switch (MPS XX-01), and the time

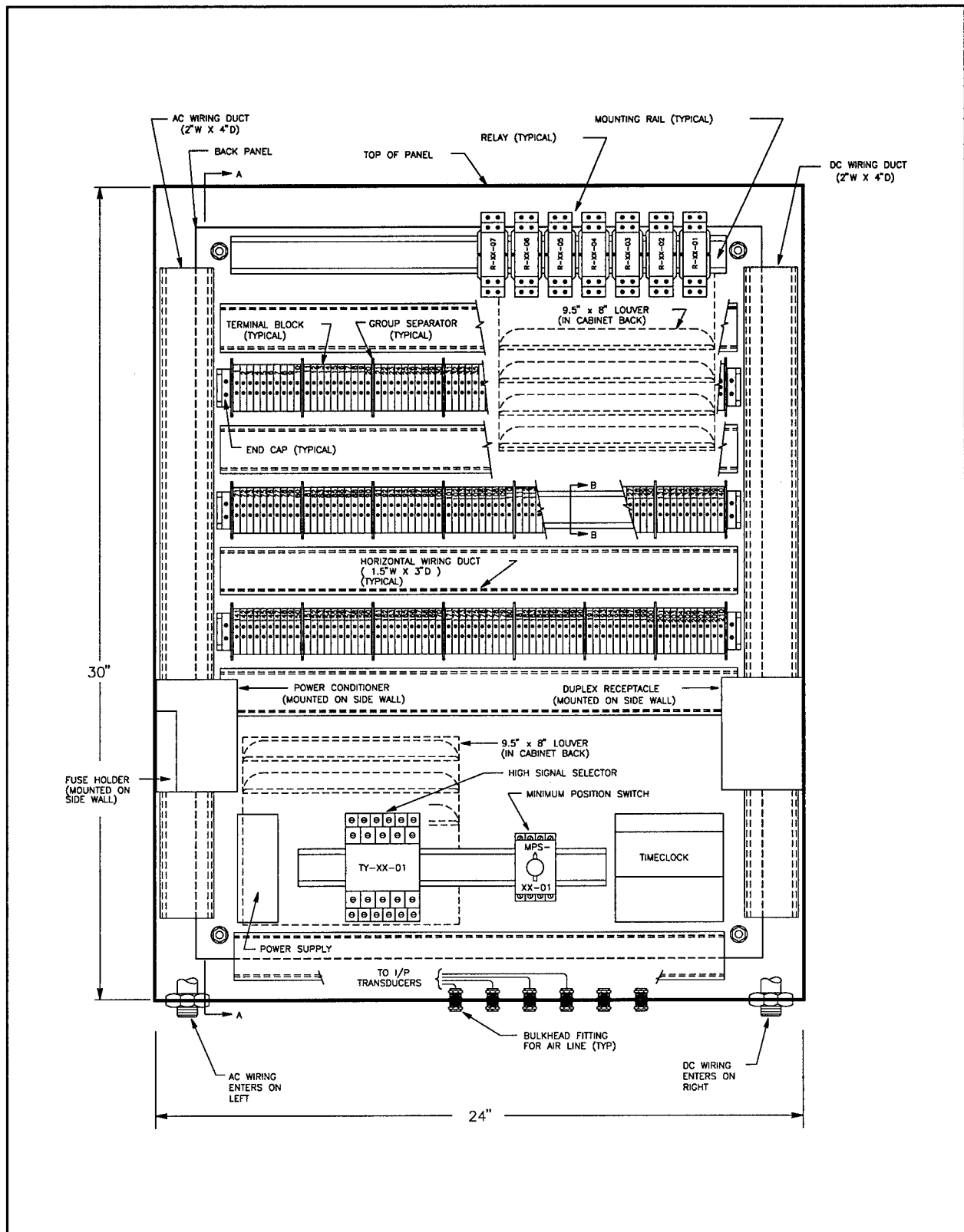

Figure 32. Standard control panel—back-panel layout.

clock (CLK XX-01). Other devices shown are the power conditioner (or surge protector), fuse holder, DC power supply, and a duplex receptacle. Note that the high signal selector (TY XX-01) and minimum position switch (MPS XX-01) are mounted on a standard size rail. This drawing also shows air louvers installed on the back of the control panel cabinet.

The Control Panel Drawing—Side View. Figure 33 shows a cross-sectional side view of the control panel. Note that it shows the panel installed 2 in. from the wall, that the devices mounted on the back panel are mounted on a back panel plate, and that there are rail mounts for the terminal blocks and current-to-pneumatic (I/P) transducers.

The Control Panel Drawing—Terminal Block Layout. Figure 34 shows the arrangement of the terminal blocks across the back of the inside of the control panel. There are three rows of terminal blocks, with each row subdivided into sets of 10 terminal blocks. The terminal block layout shows the specific function of each set of terminal blocks and is similar for each of the standard control systems; but it varies somewhat depending on the individual application requirements. In the first row of terminal blocks, terminals 1 through 10 are dedicated to the heating and ventilating system space temperature controller. Blocks 11 through 70 are not used in this application. In the second row of terminal blocks, terminals 81 through 84 are reserved for interface with EMCS to perform the time clock function (as was described in the ladder diagram section). Also, in the second row are the other EMCS interfaces and safety/interlock connections (including the freezestat, smoke detectors, and filter differential pressure switch). The third row of terminal blocks shows terminals dedicated to connections for 120 volts AC (VAC) and 24 volts DC (VDC) power distribution and the supply fan motor starter wiring terminal blocks. Detailed wiring connections to each terminal block are shown in the standard wiring diagrams.

Wiring Diagrams

Wiring diagrams for the control panel show the physical wiring connections for specific control devices. The wiring diagrams are based on requirements in TM 5-815-3. Each single-loop digital controller (SLDC) and motor starter circuit should be wired as shown in Figures 35–40. Control panel power wiring should be as shown in Figure 41. The details of the wiring diagrams are discussed further elsewhere in this Chapter and in Chapter 7.

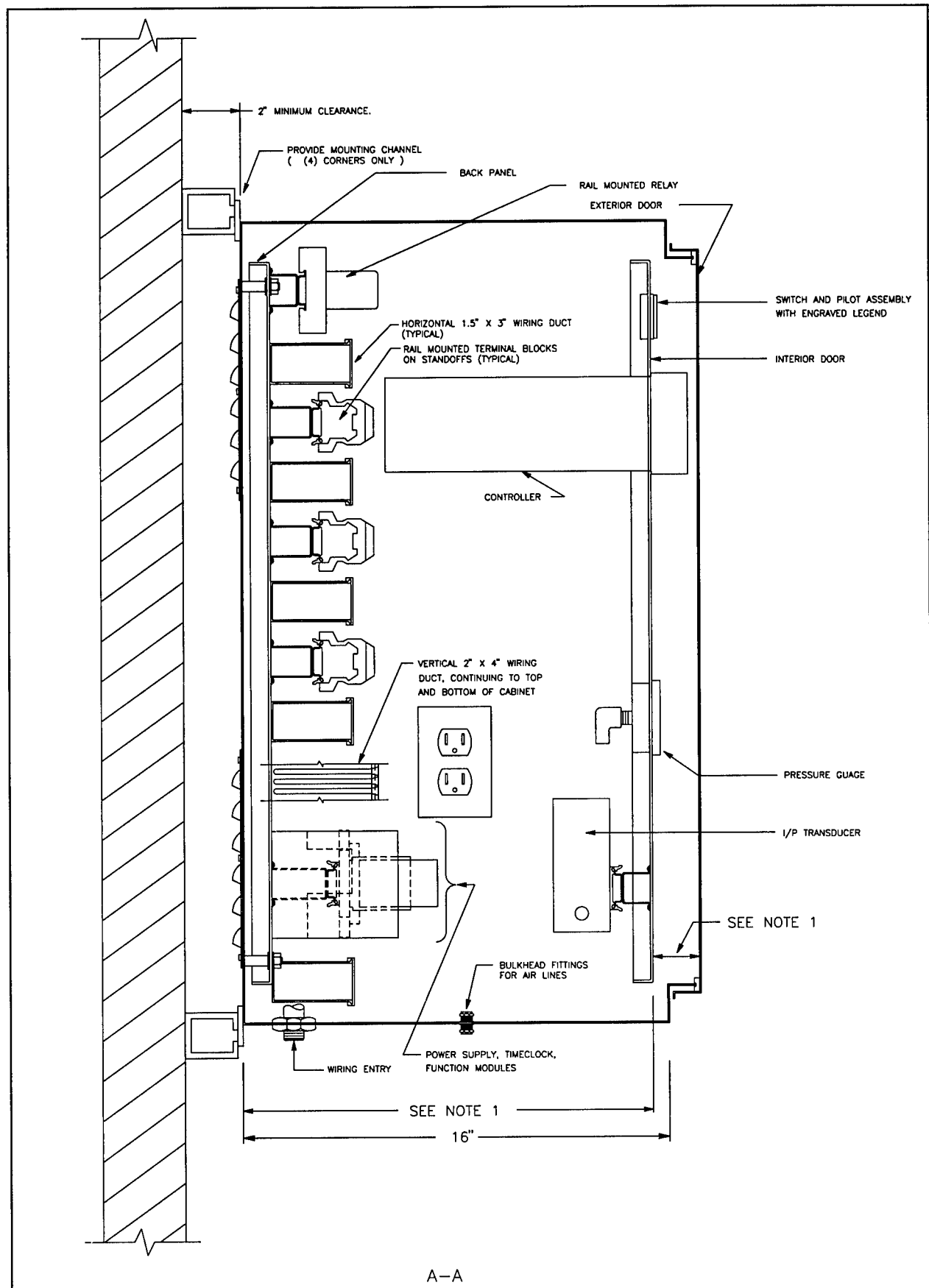

Figure 33. Standard control panel—side view.

| 1-10 | 11-20 | 21-30 | 31-40 | 41-50 | 51-60 | 61-70 |
|---|--|--|-----------------------------|-----------------------------------|----------------------------------|--|
| TC-XX-01 SPACE TEMP CONTROLLER TERMINAL BLOCKS | RESERVED FOR CONTROLLER | RESERVED FOR CONTROLLER | RESERVED FOR CONTROLLER | RESERVED FOR CONTROLLER | RESERVED FOR CONTROLLER | RESERVED FOR CONTROLLER |
| FIRST ROW OF TERMINAL BLOCKS | | | | | | |
| 71-80 | 81-84 | 85-88 | 87-90 | 91-94 | 95-98 | 99-102 |
| RESERVED FOR CONTROLLER | CLK-XX-01 EMCS REPLACE- MENT | SPACE | REMOTE START CONTACTS | TSL-XX-01 AND EMCS CONTACTS | SF-XX-01 AND EMCS CONTACTS | SMK-XX-01 AND EMCS CONTACTS SMK-XX-02 AND EMCS CONTACTS |
| | | | | | | DPS-XX-01 AND EMCS CONTACTS |
| | | | | | | 105-110 |
| | | | | | | 111 - 120 |
| | | | | | | 121 - 130 |
| | | | | | | 131-132 |
| | | | | | | 133-140 |
| | | | | | | SPACE |
| SECOND ROW OF TERMINAL BLOCKS | | | | | | |
| 141-170 | 171-180 | 181-190 | 191-200 | 201-210 | | |
| 120 V AC POWER DISTRIBUTION TERMINAL BLOCKS | 24 V DC POWER DISTRIBUTION TERMINAL BLOCKS | SF-XX-01 STARTER CONTROL WIRING TERMINAL BLOCKS | SPACE | SPACE | | |
| THIRD ROW OF TERMINAL BLOCKS | | | | | | |

Figure 34. Standard terminal block layout.

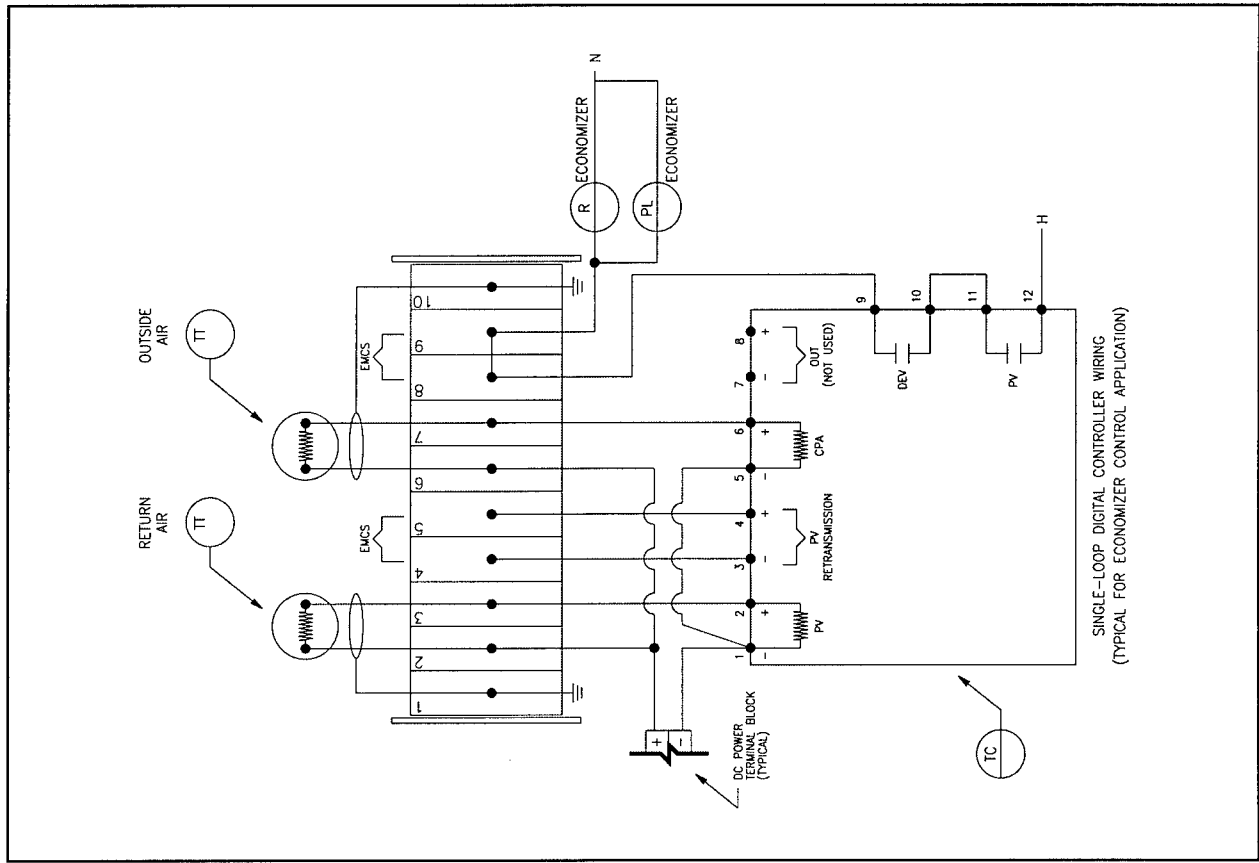

Figure 36. Standard wiring diagram for SLDC economizer.

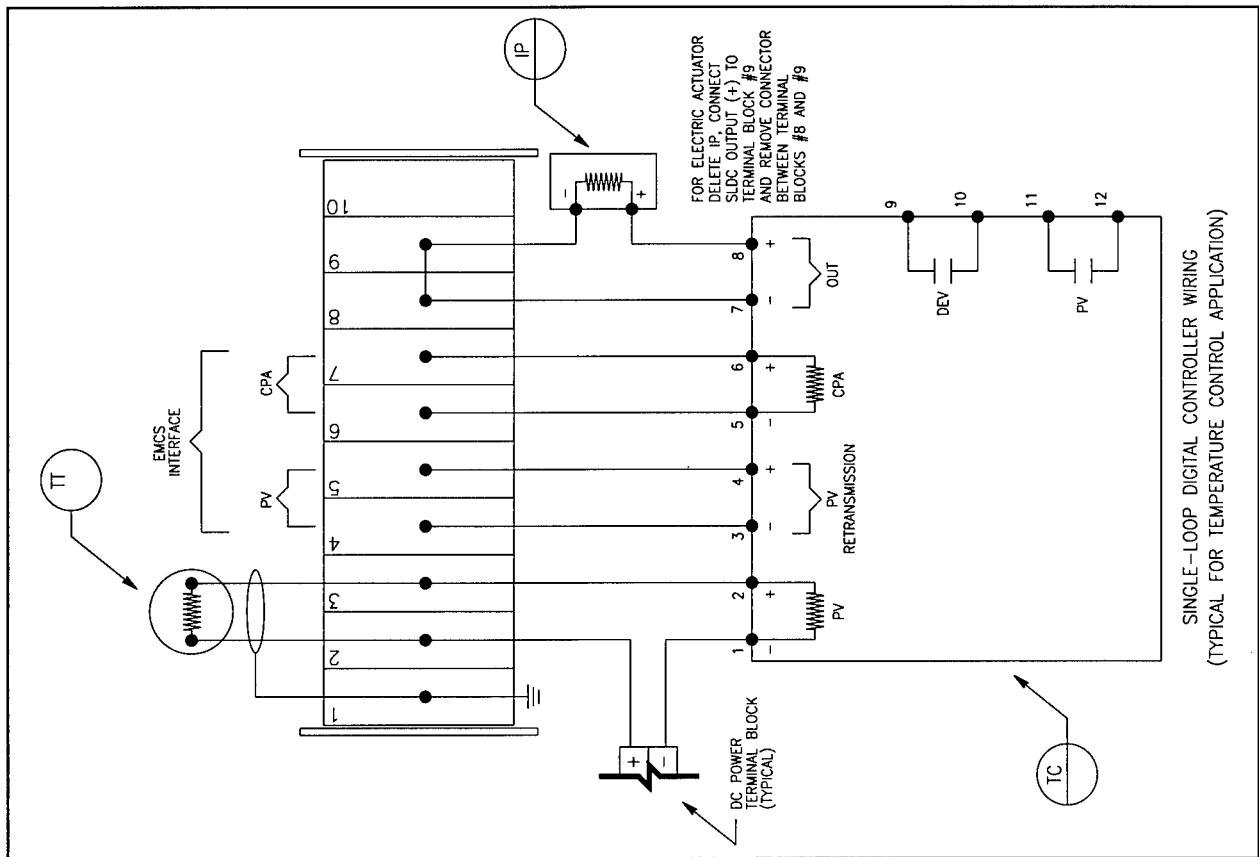

Figure 35. Standard wiring diagram for SLDC.

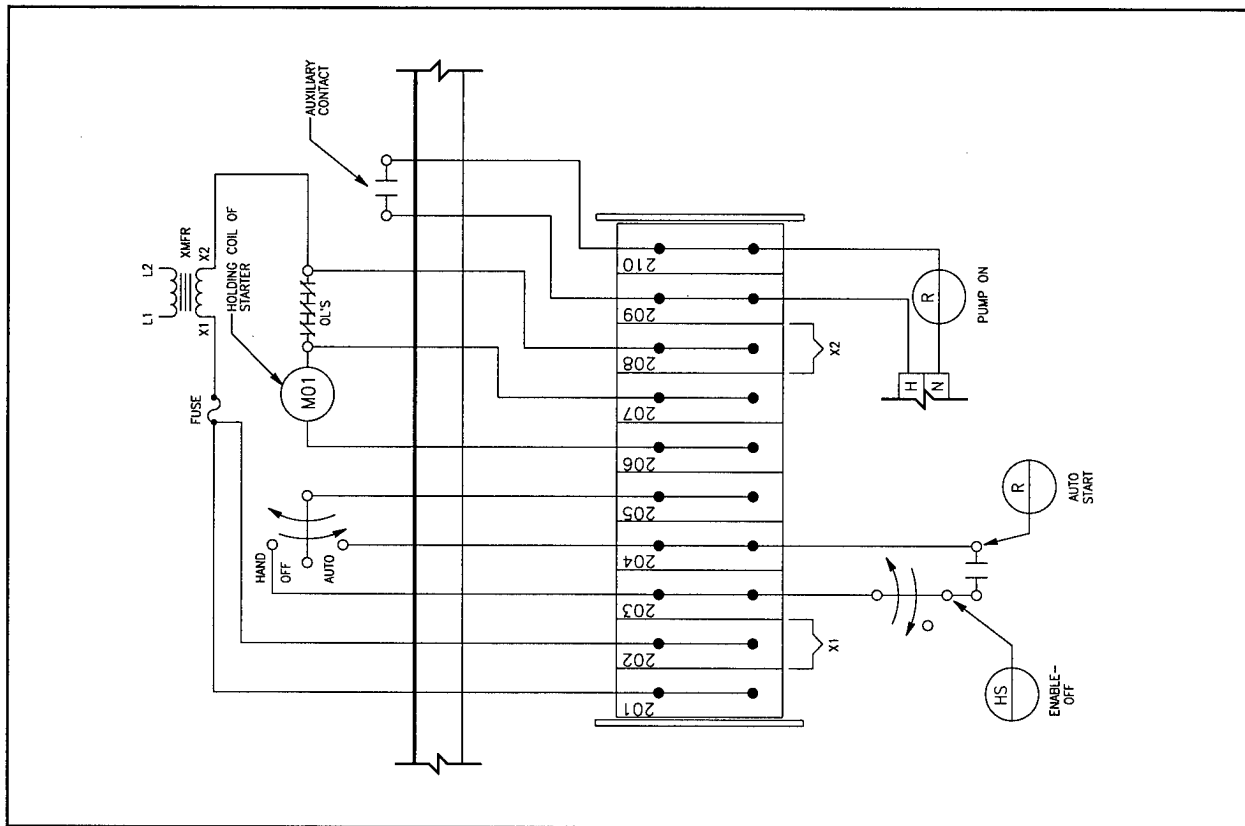

Figure 38. Return fan wiring diagram.

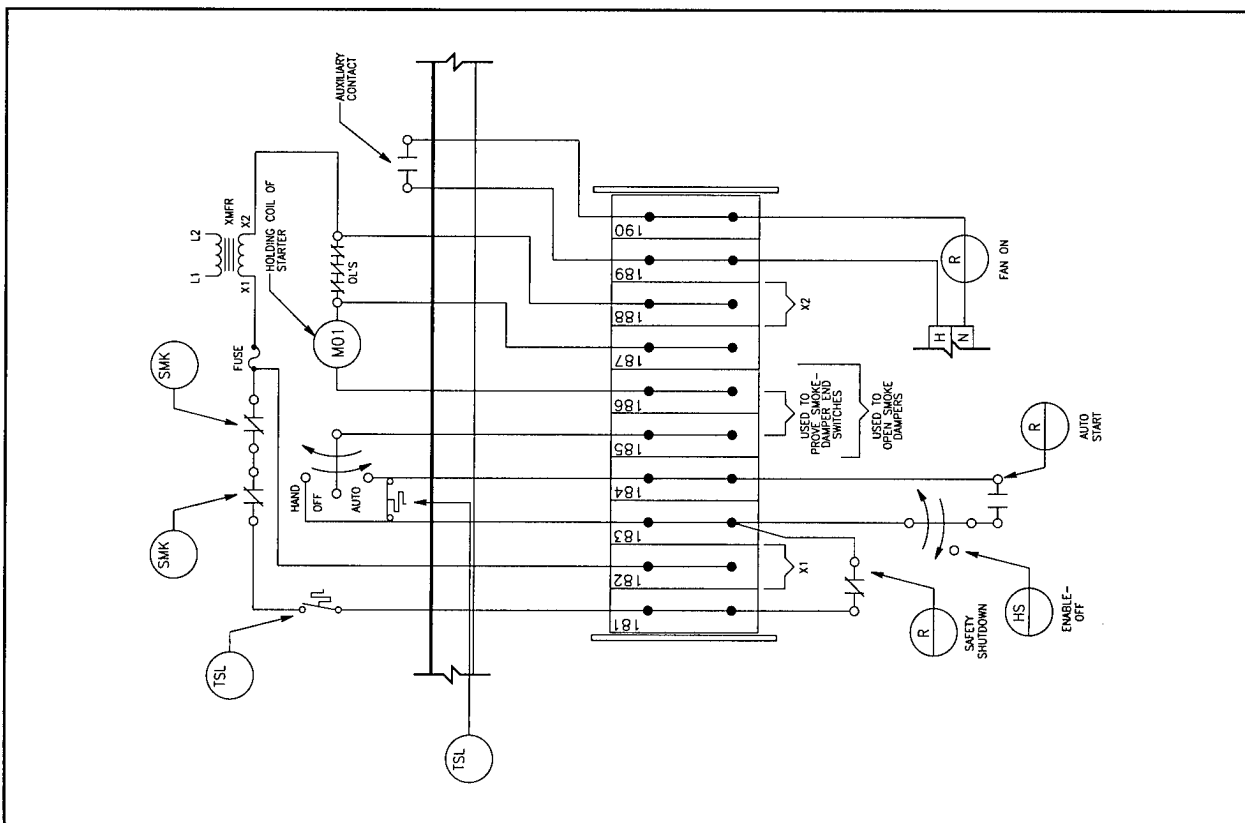

Figure 37. Supply fan wiring diagram.

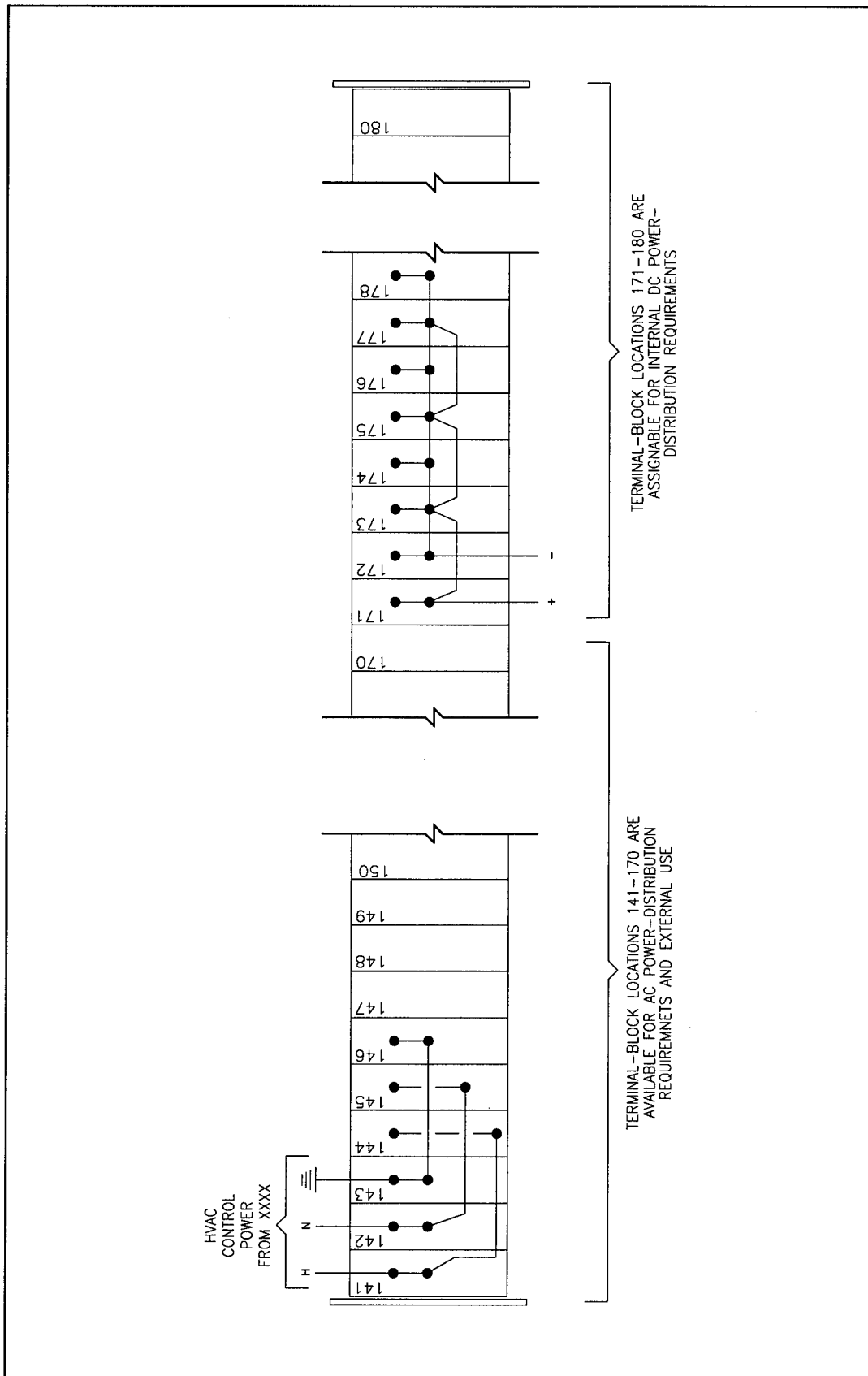

Figure 41. Control panel power wiring diagram.

Single-loop Controller Operators' Manual(s)

Single-loop controller operators' manual(s) provide detailed instruction on the operation of the controllers. Each controller manufacturer provides an operators' manual with the controller; these manuals are a necessary reference when operating the controllers. In general they are straightforward and easy to understand in regard to the basic operating features of the controller. SLDCs are described in detail in Chapter 7.

Controller Configuration Checksheets

Controller configuration checksheets are contractor-generated documents that indicate the configuration parameters for each SLDC. Configuration parameters are values keyed into the controller from the front keypad that permit the controller to perform properly for the given control application. Configuration parameters are described in detail in Chapter 7.

Commissioning Procedures

Commissioning procedures is a contractor-generated document that describes adjustments and other procedures required to make the system operational following the installation of control devices and hardware. These procedures primarily are useful as a maintenance aid in making final adjustments after a control device has been replaced. General commissioning procedures for each specific standard control system are given in CEGS-15950.

Preventive Maintenance Instructions

Preventive maintenance instructions includes contractor-supplied information about procedures and activities required to keep the control system functioning properly. Preventive maintenance activities specific to the standard control systems are described in more detail in Chapter 8.

Valve and Damper Schedules

Valve and damper schedules are useful primarily as a maintenance aid in repairing or replacing valves or dampers.

7 Maintenance

This section is intended to supplement the maintenance manual provided by the contractor. To perform system maintenance, a detailed understanding of the system operation is required. System operation is described in Chapter 6.

Tools and Spare Parts

To perform maintenance on the standard control systems and panels, a basic set of tools and spare parts is recommended. Specifications for spare parts can be found in CEGS-15950. The specifications are specific and include requirements to ensure that each device is nonproprietary; therefore, it is interchangeable between manufacturers. As a result, a single replacement item should be able to replace any like item in any control panel.

A basic tool kit consists of the following items:

- flat tip and phillips screwdrivers
- jewelers (small) screwdriver set
- digital multimeter
- milliamp current source
- digital thermometer
- 0 to 30 psi pressure gage
- wire cutter
- wire stripper
- 18-gage wire
- adjustable wrench
- an RTD simulator, decade resistance box, or a potentiometer
- calculator (optional)

Recommended spare parts include:

- single-loop digital controller
- one each of the following function modules:
 - Minimum position switch

- signal inverter
- sequencer
- high signal selector
- low signal selector
- time clock
- current-to-pneumatic transducer
- two-pole, double throw relay
- temperature transmitter and sensor assembly.

Control Hardware

Single-loop Digital Controller

Physical Description. The SLDC is an industrial-grade device used mostly by the process control industries, although this controller often is used in HVAC control applications. These controllers are available in a standard 1/4 DIN size, which corresponds to a panel cutout size of 3.62 by 3.62 in. A standard panel cutout size facilitates SLDC interchangeability. The lengths of controllers vary from manufacturer to manufacturer. The average length of an SLDC is about 7 in. Figure 42 shows a typical single-loop digital controller.

Various function keys (push buttons) on the front panel of the controller allow the user to configure and operate the controller. The controller also has one or two displays and various lights for indicating alarm relay contact closures, automatic or manual operation mode, remote or local setpoint mode, and engineering unit

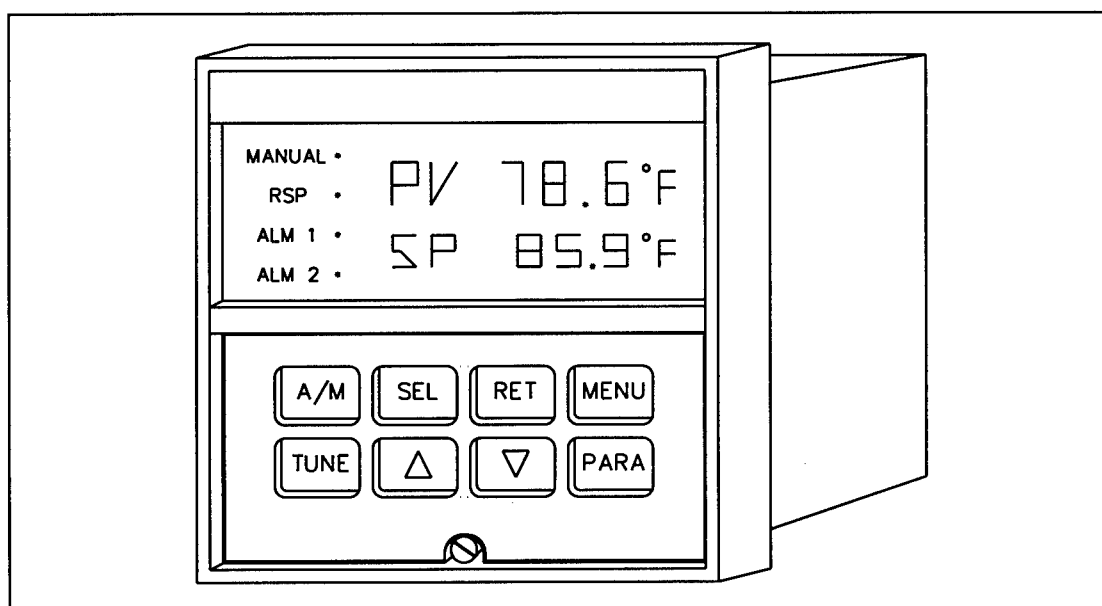

Figure 42. Front view of a typical single-loop controller.

indicators. The types of display vary, depending on the manufacturer. The displays may be vacuum fluorescent, liquid crystal, or most commonly, LED.

An SLDC is a microprocessor-based device. This means it contains a microprocessor in addition to several circuit boards, including an input/output (I/O) board and a digital logic board. It also contains random-access memory (RAM) and read-only memory (ROM). Some controllers have slots so additional boards can be added to provide for secondary outputs, communications, or additional alarm relays.

The single-loop controller is a firmware device. Functions the controller performs are executed by algorithms stored in ROM. The algorithms are not in software, thus the program is not alterable by the user. However, a high degree of flexibility in the application of the controller is available to the user so various control parameters can be keyed (or configured) into the controller. These configuration parameters are used in the execution of the controller's fixed program.

At the rear of the controller are terminal connections for 120 VAC power, 4 to 20 mA input, 4 to 20 mA output, and alarm/relay contact outputs. The controller chassis may be metal or plastic, and it is typically removable by a screw on the front of the unit.

SLDC Operation. Operation of a SLDC is relatively straightforward. The displays are used to indicate the controller's setpoint and process variable (temperature, pressure, flow, etc.). The upper display always indicates the value of the process variable, and the lower display shows the controller setpoint. By pushing the appropriate keys the displays also can be used to read the controller's output signal (%) and other parameters of interest such as contact or alarm setpoints and the P-, I-, and D-mode constants. The controller can be operated by the user in the manual mode by pushing the manual mode button. In manual mode, the up and down arrow keys can be used to manually control the output. Self-tuning is another operator feature typically used during the commissioning process to automatically set the P-, I-, and D-mode constants.

SLDC Configuration. Configuring the controller is a procedure whereby various control options can be selected by manually keying in the appropriate configuration parameters. Typically, one of the keys is used to scroll through the main menu headings. These headings might include control, input, output, and alarm/contact settings. Another key is used to scroll through the individual parameters under a given main menu heading. The individual parameters then can be changed using the up and down arrow keys. Some of these parameters include P, I, and D values, control setpoint, scaling values for the input signals, direct or reverse control action,

maximum output signal, alarm/contact definition, and alarm/contact setpoints. With some controllers, additional configuration may be required via the setting of dip switches or placement of jumper pins.

Supplemental configuration of the controller may be required by setting dip switches or jumpers inside the unit. These settings also may be done in the field. For example, the user may be required to set a couple of dip switches for a particular controller to configure the controller to recognize a remote setpoint input signal and to configure the alarm relay contacts as normally open (NO).

For storage of configuration parameters that are keyed in, the controller contains some type of programmable read-only memory (PROM) or battery back-up RAM. Configuration parameter memory storage typically will exceed 5 years.

Configuration parameters are keyed into the controller to prepare it to be used in a given application. The values are keyed in from the front panel of the controller. For each application the designer is required to calculate and/or select some of the controller configuration parameters. An example is an application in which one controller is to be used to reset the setpoint of another controller. The designer must calculate the configuration parameters of the reset controller that will result in the desired reset schedule. Another example is an application in which a controller is to be used as an economizer controller. The relay/contact setpoints must be calculated and provided by the designer. Configuration parameters selected by the designer are to be included on the equipment schedule drawing. These and any additional parameters, as determined necessary by the contractor, will be included in a configuration checklist developed by the contractor. The equipment schedule and configuration checklist are provided as Posted Instructions to the government by the contractor. These documents are useful for system commissioning and O&M.

Process Variable. PV input is the controlled variable (i.e., temperature, duct static pressure, humidity, flow). According to the CEGS-15950, the PV signal must be within the range of 4 to 20 mA. It is received from a transmitting device as an analog signal. The controller scales the 4 to 20 mA analog signal to correspond to the range of the transmitter. For example, in a heating hot water temperature control application, the temperature transmitter range is to be 100 to 250 °F. The controller converts (or scales) the 4 to 20 mA signal so it recognizes 4 mA as 100 °F and 20 mA as 250 °F with a linear relation between the extremes. This 100 to 250 °F range is sometimes referred to as the span of the controller. Establishing the span of the controller is done as part of the configuration process.

Scale. As described in process variable, the controller converts (or scales) the 4 to 20 mA input signal to the appropriate engineering units to match the span of the transmitter. Field scaleable describes a feature whereby the user can establish the span of the controller input in the field (on-site) via the configuration process.

PV Retransmission. PV retransmission provides a separate 4 to 20 mA output signal identical to the PV input signal. It is electrically isolated from the other controller inputs and outputs. Digital communications also are available with most controllers. The types vary, but most are RS-422 and RS-485. The digital communications feature is not used by the Corps as a standard feature.

Control Setpoint. The control setpoint is the value of the PV that the controller is to maintain via the proportional, PI, or PID control mode. The control setpoint may be set locally from the front keypad or set remotely.

CPA. The CPA is the act of setting, or adjusting, the control setpoint via a 4 to 20 mA signal from an external device. The signal is received at the controller's remote setpoint (RSP) input. The 4 to 20 mA signal is scaled by the controller to correspond to the same range as the PV. Some controllers permit scaling of the RSP to a range different from that of the process variable. As a rule, the designer should not use this feature; it is not necessary for the applications described in TM 5-815-3. Use of the scaling of the RSP will deviate from the standardization concept. The RSP always should be configured to the same range as the PV.

Ratio. The ratio is used in conjunction with the RSP input signal. The scaled RSP signal is multiplied by the value of the ratio. For example, assume that the 4 to 20 mA RSP input to the controller is from an airflow transmitter with a span of 0 to 1,000 fpm and the transmitter is installed in a duct with a cross-sectional area of 10 ft². The controller can be configured (scaled) to recognize the 4 to 20 mA signal as 0 to 10,000 cfm. Assume that we would like to ratio this scaled signal. As shown in Table 3, when the RSP input is 20 mA, with the ratio set to 1.2, the resulting setpoint of the controller will be 10,000 cfm x 1.2 = 12,000 cfm. Table 3 shows other SLDC inputs and outputs with the ratio set to 1.2.

Bias. Bias is used in conjunction with the RSP input to offset (add or subtract) a portion of the RSP signal. Biasing of the signal is performed by the controller after the signal is scaled and ratioed. Using the previous example, assume that the 4 to 20 mA RSP input is from an airflow transmitter with a span of 0 to 1000 fpm. The duct in which the transmitter is located has a cross-sectional area of 10 ft²; therefore, the controller is configured to scale this signal to 0 to 10,000 cfm (1000 fpm x 10 ft²). Referring to Table 4, when the flow is 1000 fpm, the RSP input is 20 mA, the scaled

Table 3. Example of SLDC ratio functions.

| Sensed Flow (fpm) | RSP Input (mA) | Scaled CPA (cfm) | Ratioed CPA (cfm) |
|-------------------|----------------|------------------|-------------------|
| 0 | 4 | 0 | 0 |
| 500 | 12 | 5000 | 6000 |
| 1000 | 20 | 10,000 | 12,000 |

fpm = feet per minute cfm = cubic feet per minute
 rsp = remote setpoint CPA = control point adjustment
 mA = milliamps

Table 4. Example of SLDC ratio and bias function.

| Sensed Flow (fpm) | RSP Input (mA) | Scaled CPA (cfm) | Ratioed CPA (cfm) | Biased CPA (cfm) |
|-------------------|----------------|------------------|-------------------|------------------|
| 0 | 4 | 0 | 0 | 0 |
| 500 | 12 | 5000 | 6000 | 3000 |
| 1000 | 20 | 10,000 | 12,000 | 9,000 |

fpm = feet per minute cfm = cubic feet per minute
 rsp = remote setpoint CPA = control point adjustment
 mA = milliamps

signal is 10,000 cfm, and, assuming the ratio is set to 1.2, the ratioed signal is 12,000 cfm. With the bias set to be minus 3000, the resulting setpoint of the controller will be 12,000 cfm – 3000 cfm = 9000 cfm.

Analog Output (OUT). OUT is a 4 to 20 mA control signal used to modulate the controlled device. Its upper and lower limits can be set during the configuration process. OUT is displayable on the front panel of the controller in units of percent (%), where 0 percent equals 4 mA and 100 percent equals 20 mA.

Manual Reset. MR is a configuration parameter that can be defined as the controller's analog output when the PV equals the control setpoint (i.e., error = 0) while the controller is being operated in the proportional-only mode. Mathematically, MR is a constant in the control algorithm that is directly added to the output signal. A discussion of the P, PI, and PID algorithms is given in Chapter 3. Prior to the ready availability and wide use of PID controllers, manual reset was used as a final tuning adjustment in the application of proportional-only controllers to get the controlled variable to equal the setpoint. It is particularly useful in the application of controllers to be used in setpoint reset applications. MR is input into the controller during the configuration process in units of percent (%). MR is not to be confused with the bias used in conjunction with the RSP.

Auto/Manual. The auto/manual modes are the two control modes in which the controller can be operated. When in the automatic (auto) mode, the controller operates in a closed loop as it attempts to keep the PV at the control setpoint. In the manual mode, the controller operates in an open loop with the output signal at a value (or level) that can be varied by the operator.

Mode Constants. Mode constants are the proportional, integral, and derivative values. These values are used by the controller's algorithm during operation in the automatic control mode.

Direct- and Reverse-Acting. Direct (DIR)- and reverse (REV)-acting are terms associated with the control action of the controller. A DIR-acting controller's output increases as the PV rises above the control setpoint; it decreases as it drops below. Likewise, a REV-acting controller's output decreases as the PV rises above the control setpoint; it increases as it drops below.

Self-Tuning. Self-tuning is a feature whereby the controller automatically selects its proportional, integral, and derivative control mode constants. CEGS-15950 requires that the self-tuning mode be activated manually. Typically, all that is required is to push the controller's self-tune button.

PV Contact. PV contact is a relay contact closure output that is open or closed, depending on the value of the PV. The PV contact frequently is referred to as a PV alarm relay contact by SLDC vendors. Configurable parameters associated with the PV contact are: PV contact setpoint, normally open or normally closed, and DIR- or REV-acting. A normally open, DIR-acting PV contact closes when the PV rises above the PV contact setpoint. A normally closed, DIR-acting PV contact opens when the PV rises above the PV contact setpoint. A normally open, REV-acting PV contact closes when the PV drops below the PV contact setpoint. A normally closed, REV-acting PV contact opens when the PV drops below the PV contact setpoint.

Deviation Contact. DEV contact is a contact closure output actuated by the size of the difference or deviation between the process variable and control setpoint. It is often referred to as a DEV alarm by SLDC vendors. This contact has a user-selectable setpoint that is set to the desired deviation between the PV and the control setpoint. Note that the control setpoint, as described previously, is different than the contact setpoint. The contact setpoint (DEV) may be positive or negative and, as with the PV contact, the relay contact output may be configured to normally closed or normally open. Table 5 shows an example of the operation of a DEV contact for a typical configuration.

Table 5. Example of SLDC deviation contact function.

| DEV SP = +8 °F; Switching Differential = 2 °F; DEV Contact is NO | | | |
|--|---------|----------|--------------------|
| PV (°F) | SP (°F) | DEV (°F) | DEV Contact Status |
| 70 | 63 | +7 | Open |
| 70 | 62 | +8 | Open |
| 70 | 61 | +9 | Closed |
| 70 | 62 | +8 | Closed |
| 70 | 63 | +7 | Open |

DEV = deviation
 SP = setpoint
 NO = normally open

SLDC = single-loop digital controller
 PV = process variable

Switching Differential. The switching differential is a small deadband on both sides of a contact's setpoint. It is sometimes referred to as hysteresis or deadband. It prevents rapid opening and closing (chattering) of the contact output when the condition required to activate the contact is close to its setpoint. Switching differential is a configurable parameter.

Controller Problem Diagnosis and Troubleshooting. The SLDC can be expected to be a low maintenance device. Problem diagnosis and troubleshooting steps to take are shown in Table 6. Often, problems with the controller are due to improper setting of its configuration parameters. The configuration parameters for each controller are supplied by the contractor and should be reviewed to determine if they have been correctly input into the controller. If you suspect that the settings are not correct, compare them to another controller used in a similar application.

Controller Calibration and Adjustment. The electronics inside an SLDC are factory calibrated; experience to date suggests that they should never require any field calibration. If they do require calibration, refer to the controller operators' manual. The only adjustments that may be required for the controller is setting of the controller configuration parameters. These are set initially by the contractor when the controller is installed and are recorded on the controller configuration check-sheet. In most cases these parameters should not require any further adjustment for the life of the controller.

Controller configuration parameters that may require field adjustment include: the PID tuning constants, PV contact setpoint, deviation contact setpoint; and for the reset controller (also called outside air temperature controller), reset schedule parameters that include the proportional band, setpoint, and the maximum output signal. Reset controller adjustments are described in Chapter 4.

Table 6. Controller problem diagnosis and troubleshooting.

| Problem | Troubleshooting/Possible Cause |
|---|--|
| No display (controller appears dead) | Circuit breaker to panel is off. Fuse in lower left corner of panel blown. Fuse inside controller is blown. Controller not seated properly in housing. Power wiring to controller not wired properly. Internal jumper set incorrectly (i.e., it may be jumpered for 220 VAC instead of 115 VAC). If none of the above, repair or replace controller. |
| Controller display is unusual (does not display the process variable or setpoint) | Push the "DISPLAY" or "SCROLL" button (you may have to push it several times). |
| Improper display of process variable (upper display) | If it displays a code, word, or lettering, this usually means that the sensor input is disconnected, wired incorrectly (reverse polarity), or the sensor is faulty. Refer to the controller operators' manual for exact interpretation of displayed codes. The sensor may be out of its normal sensing range (i.e., if a hot water sensor range is 100 to 250 °F and the water temperature it is reading is 90 °F, the controller will display a code to indicate there is a problem. In this case the controller will return to normal operation when the water temperature increases. The controller may be configured wrong. Check the contractor supplied "controller configuration checksheet" to ensure that the controller process variable input parameters are consistent with those on the checksheet. The input transmitter may be faulty (see "Transmitter Problem Diagnosis and Troubleshooting") If all controllers in the panel have an improper process variable display, the 24 VDC power supply inside the control panel may be faulty (this power supply is used to power all sensors). |
| Displays do not respond to front panel keys | Determine if there is a fault (is there a fault light and is it lit?). If there is a fault, acknowledge the fault by pushing the appropriate button (usually this is the "ACK" button). |

Controller Repair/Replacement. In general it probably is best to simply replace a malfunctioning controller. The time and effort required to repair a controller may not be cost justified. By design and specification, SLDCs are fully interchangeable, not only between applications but also between manufacturers. This is due to their 1/4 DIN physical size, 4 to 20 mA input/output requirements, and the functional capability of the controllers. Therefore, replacement controllers may be obtained from the most convenient and cost-effective source. However, not every SLDC on the market will meet specifications. Most will meet basic application requirements; but to meet interchangeability requirements, the SLDC must meet all the requirements in CEGS-15950.

Caution must be exercised in selecting standard controllers. It is not always evident from a particular controller's specification sheet that the unit will meet CEGS-15950 requirements. Controllers known to meet CEGS-15950 requirements are:

- Honeywell UDC 3000
- Powers 512
- Powers 535
- TCS Basys SD-1000
- Yokogawa UT-30
- Yokogawa UT-40
- Taylor Micro Scan 500.

The TCX for HVAC Controls* may be consulted for a current list of controllers known to meet CEGS-15950 requirements or to check requirements of a prospective replacement controller. Controller features to look for that may not be evident from a vendor's specification sheet include:

- The PV and DEV contacts must be separate such that they have separate external connections for wiring purposes.
- The control (or primary) output from the controller should not be used as a relay contact. There should be two separate relay contacts for contact closure outputs in addition to a 4 to 20 mA control output.
- Do not use a controller that continuously self-tunes. The controller design should be such that the operator can turn the self-tune feature on and then disable it when self-tuning is completed.
- The controller depth should not exceed the depth of the control panel clearance available.

A replacement controller must be configured for the application it is to be used in. The same configuration parameters from the defective controller should be used in the replacement controller. These parameters can be found on the controller configuration checksheet provided by the contractor as a contract submittal when the control system was originally installed. CEGS-15950 requires that the controller configuration checksheet be included with the system contractor-provided O&M manual. The operators' manual accompanying the replacement controller will be needed to configure the controller.

* U.S. Army Engineering District, Savannah, P.O. Box 889, Savannah, GA 31402-0889; tel. 912-652-5386.

Temperature Transmitter

Physical Description. A temperature transmitter (TT) is used in the standard HVAC control systems to measure temperature. Actually it is a two-part assembly consisting of a sensor and a transmitter. The sensor is an RTD (resistance temperature device), and the transmitter is an electronic device that generates a 4 to 20 mA signal based on the resistance of the sensor.

Figure 43A shows a typical hydronic system application. Figure 43B shows a typical duct air temperature-sensing application. In each case the temperature sensor is a platinum RTD and is connected to an integrally mounted TT that provides a 4 to 20 mA output signal. In the duct application, the sensor is a continuous averaging-type element. Averaging elements are used in applications where there is potential for stratification of the air stream as is the case on the downstream side of a coil and in mixed air temperature-sensing applications. Outside and return air temperatures usually can be measured adequately with a point-type sensor. A sunshield is used to house an outdoor temperature sensor, preventing sunlight (either direct or reflected) and rain from directly striking the sensing element.

RTDs have been around for over 50 years and come in many different types and sizes. Unlike other sensors, they are extremely accurate and drift little over time. The basis of the RTD concept for measuring temperature is that the resistance of all metals increases as their temperature increases. Several metals are used in RTDs, but platinum RTDs have been found to be the best choice and are specified in CEGS-15950. Nickel RTDs are somewhat common and are low cost, but their temperature-resistance response is quite nonlinear, and the response tends to drift with time.

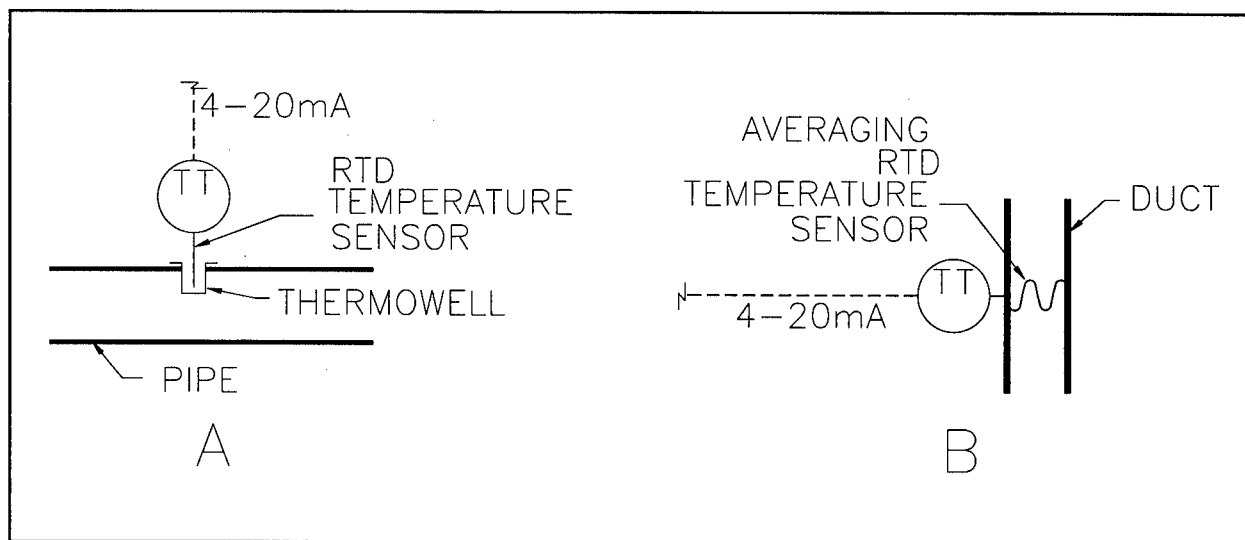

Figure 43. Typical temperature transmitter applications.

RTDs are manufactured to provide a reference resistance at the reference temperature. The reference temperature of most RTDs is 32 °F (0 °C). For the platinum RTDs specified in CEGS-15950, the reference resistance is 100 ohms at 32 °F (0 °C).

The temperature transmitter measures the resistance of the RTD and adjusts its milliamp output current in a linear manner. Figure 44 shows the relation between the input temperature (sensed by the RTD) and the output current from the transmitter for two different transmitter ranges. For example, for a -30 to 130 °F transmitter, at -30 °F, the transmitter output is 4 mA; at 130 °F the transmitter output is 20 mA. Whereas for a 40 to 140 °F transmitter, at 40 °F the transmitter output is 4 mA; at 140 °F the transmitter output is 20 mA.

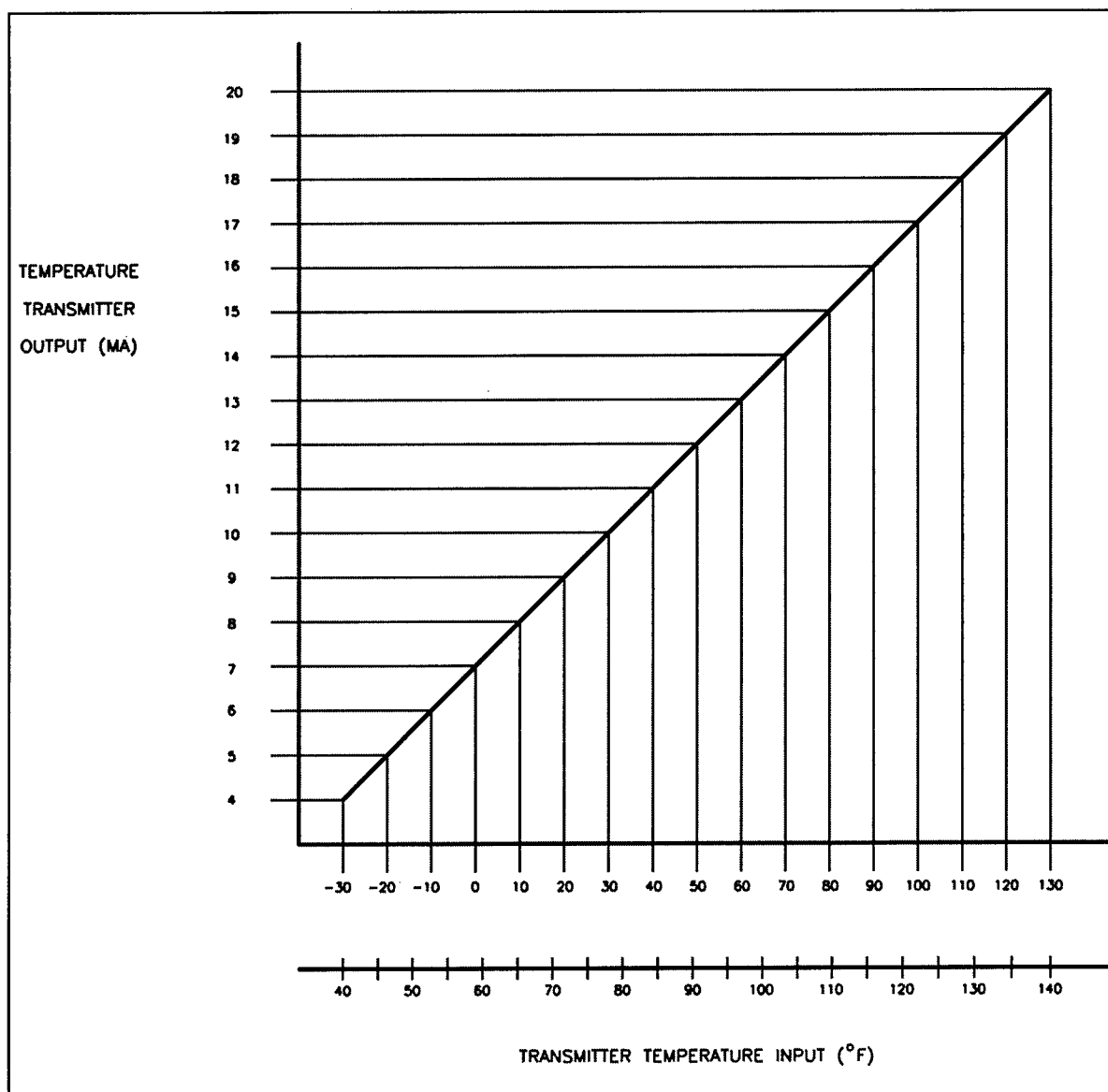

Figure 44. Temperature transmitter output versus sensed temperature input.

All transmitters are required to be loop-powered. A loop-powered device does not have an external power source connected to it as a separate input. Loop-powered devices have only two wiring connections. One connection provides the 4 to 20 mA signal output to the device that the transmitter is sending its signal to. The other wiring connection is to the positive terminal of the direct current power supply located inside the standard control panel. This concept is discussed in greater detail in the "Electronics" section of this chapter.

TTs are factory-calibrated for their specified range. The range of the transmitter is usually indicated on the transmitter cover or housing. CEGS-15950 requires the transmitter output error to not exceed 0.1 percent of the calibrated measurement/span. This means that, for a 4 to 20 mA transmitter with a 16 mA output range, the output should be within ± 0.016 mA of the expected output for a specific resistance input. Experience has shown that new RTD transmitters, which are factory calibrated, rarely need calibration in the field. CEGS-15950 requires that the transmitters have offset/zero and span adjustments for calibrating. The adjustments that can be made are generally limited to ± 20 percent.

CEGS-15950 calls for the RTD transmitters to accept a three-wire, 100 ohms RTD input. CEGS-15950 also calls for the RTD transmitters to be calibrated to produce a linear 4 to 20 mA output corresponding to the temperature range indicated. The standard ranges for transmitters, as required by CEGS-15950 are:

- conditioned space temperature 50 to 85 °F
- duct temperature 40 to 140 °F
- duct temperature for return-air temperature
economizer -30 to 130 °F
- high-temperature hot-water temperature 200 to 500 °F
- chilled-water temperature 30 to 100 °F
- dual-temperature water 30 to 240 °F
- heating hot-water temperature 100 to 250 °F
- condenser-water temperature 30 to 130 °F
- outside-air temperature -30 to 130 °F

The RTD connected to the TT must have three leads to help balance the circuit, thereby helping to ensure that the sensed temperature is accurate. Within a typical RTD transmitter are three legs of a wheatstone bridge and other electronic components. The RTD itself is the fourth leg of the bridge circuit. Figure 45 shows a diagram of the bridge/RTD circuit. The two extension wires add additional lead resistance to the bridge circuit, causing the circuit to become unbalanced and causing inaccuracy in temperature readings. This problem can be minimized by

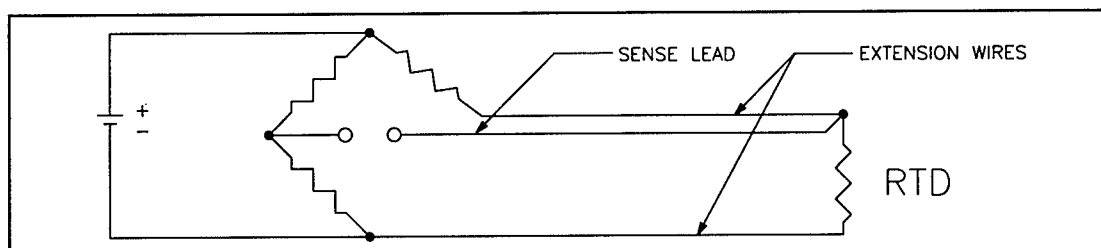

Figure 45. Balanced RTD bridge circuit.

using extension wires of the same length and by adding a wire known as a sense lead to the circuit as shown in Figure 45. With this configuration, the two extension wire resistances cancel each other because they are on opposite legs of the bridge, which creates a balanced bridge circuit that permits resistance changes in the circuit to be solely due to that of the RTD.

TT Problem Diagnosis and Troubleshooting. The TT can be expected to be a low maintenance device. Problem diagnosis and troubleshooting steps are shown in Tables 7 and 8.

The temperature conversion tables in Appendix B can be used as an aid in determining if a TT is operating correctly. In most cases the TT will be connected to a SLDC. The two wire output from the TT is connected to the PV input connections on the back of the controller. These connections should (according to CEGS-15950 requirements) be labeled on the input wires to the controller. If not, most controllers show a wiring diagram on the controller housing that can be used to locate the PV input connections.

The tables in Appendix B can be used to convert either the measured input voltage or current to the appropriate temperature reading that should be displayed on the controller (upper display). The tables in Appendix B also can be used to convert the CPA (or remote setpoint) input to temperature. In the economizer application there is a TT connected to both the PV and CPA (remote setpoint) inputs. The CPA input temperature usually is displayed on the lower display of the controller.

There are temperature conversion tables in Appendix B for each controller that is known to meet CEGS-15950 requirements. Under the temperature heading, each table has several columns that correspond to the various ranges of TT (i.e., -30 to 130 °F, 100 to 250 °F, etc.). There are several tables because not all controllers have the same input resistance. For example, the Honeywell, Powers, and Yokogawa controllers all use a 250 ohm input resistor, and the TCS controller uses a 100 ohm resistor. Also, the PV and CPA input resistance may be different.

Table 7. Transmitter problem diagnosis and troubleshooting.

| Problem | Troubleshooting/Possible Cause |
|--|--|
| No output (usually indicated by an unusual controller display) | <p>The 24 VDC power supply inside the control panel may be faulty (this power supply is used to power all sensors).</p> <p>The transmitter input may be disconnected, wired incorrectly (reverse polarity).</p> <p>The sensor may be faulty and need to be replaced.</p> |
| Output is incorrect (the controller PV display is different than the thermometer or gage indication) | <p>Use procedures described in Table 8 and "Problem Diagnosis and Troubleshooting" to determine if transmitter output is correct.</p> <p>If output is not correct, calibrate the transmitter. Refer to "Transmitter Calibration" and/or manufacturer's instructions.</p> <p>Transmitter may be connected to too much resistance on its output. Check the input resistance (in spec sheets) of the device(s) or controller connected to the transmitter. Typically the total resistance cannot exceed 600 ohms. (Also refer to the "Electronics" section of this manual.)</p> |
| Output is erratic | <p>Check for loose connections.</p> <p>The 24 VDC power supply might be faulty. If all of the transmitters are erratic, the 24 VDC power supply may be providing an erratic voltage.</p> <p>Check sensor grounding shield to be sure it is grounded at both ends of the sensor cable.</p> |
| Output greater than 20 mA | Input wiring to transmitter wiring may be disconnected. |
| Output less than 4 mA | Input wiring to transmitter (i.e., RTD) wiring may be shorted or faulty. |
| Output cannot be calibrated full span (zero and span) | <p>The zero and span must be within the limits specified on the nameplate of the transmitter.</p> <p>Transmitter may be connected to too much resistance on its output. Check the input resistance (in spec sheets) of the device(s) or controller connected to the transmitter. Typically the total resistance cannot exceed 600 ohms. (Also refer to the "Electronics" section of this manual.)</p> <p>If zero and span limits cannot be reached during calibration, replace the transmitter.</p> |

To use the temperature conversion tables, find the correct table for the brand of controller you are using and the type of input you are measuring (either PV or CPA). Under the temperature heading, locate the appropriate range of the transmitter. (The range of the installed transmitter can be found on the transmitter housing or on the posted instructions in the equipment schedule). Measure the voltage across the input connections at the controller. (Note that it is easiest to measure voltage. To measure current, one of the input connections must be removed so the test meter leads can be placed in series with the circuit.) Locate the measured voltage reading

Table 8. Transmitter problem diagnosis and troubleshooting—incorrect output.

| Steps to Take if the Transmitter Output Appears to be Incorrect |
|--|
| <p>The output from the transmitter may appear to be incorrect as determined by comparing the controller PV display (upper display) to the thermometer or gage located in the pipe or duct (depending on what the controller is measuring). For example, the controller upper controller display indicates that the duct temperature is 85 °F, but the thermometer located in the duct reads 70 °F.</p> <p>If the output from the transmitter appears to be incorrect, compare the controller “process variable high” and “process variable low” configuration parameters to the high and low range of the temperature transmitter. In order for the controller to display the correct temperature value, the input range of the controller must match the range of the temperature transmitter. For example, if the temperature transmitter range is 40 to 140 °F, then the controller input range must also be 40 to 140 °F. If these ranges do not match, adjust the controller configuration parameters to match the transmitter range.</p> <p>The tables in Appendix B and C can be used to assist in diagnosis.</p> |

under the V column in the table, then find the corresponding temperature under the temperature column. Compare this temperature to that indicated on the thermometer located next to the TT.

Although, it is unlikely that the RTD is faulty, it can be checked by disconnecting it from the transmitter and placing it in a glass of water of a known temperature. Measure the resistance of the RTD using an accurate digital ohmmeter and refer to the temperature-versus-resistance chart for the particular RTD. Appendix C gives the standard resistance values for 100 ohm-platinum RTDs for Fahrenheit and Celsius scales. The specifications call for the RTD to have an accuracy of approximately ± 1 °F. RTDs cannot be calibrated or fixed so they should be replaced if they fail or drift to where the inaccuracy is more than ± 2 °F.

TT Calibration. TT calibration procedures have been written in as much detail as possible while remaining generic enough to apply to any vendor’s TT. Recalibration of TT may be required once a year. If the device requires calibration more often than this, it should be replaced.

- Calibration check. The procedure described under the section “TT Problem Diagnosis and Troubleshooting” in this chapter can be used to determine if the TT is operating correctly.
- Calibration procedure. The purpose of calibrating a TT is to obtain an accurate output from the transmitter for a specific RTD-resistance input that corresponds to a certain temperature. CEGS-15950 requires the transmitter to have zero and span screws for calibration. This example will cover the calibrating procedure for a 40 to 140 °F, 100-ohm RTD transmitter.

The following equipment will be needed for the calibration procedure:

- RTD simulator, decade resistance box, or a potentiometer
- digital multimeter
- small/jeweler's screwdriver
- "Standard Resistance Values for 100 Ohm Platinum RTD Tables" (Appendix D)
- "Transmitter mA Output Versus Process Variable Input Tables" (Appendix C)
- calculator (optional).

The following steps should be followed:

- Step 1. Identify the operating range of the transmitter (the range of the transmitter should be printed on the transmitter housing, and on the equipment schedule).
- Step 2. Disconnect the wires leading from the RTD to the transmitter by loosening the screws at terminals 3, 4, and 5, as shown in Figure 46.
- Step 3. Connect the RTD simulator or decade resistance box to the RTD input terminals of the transmitter as shown in Figure 46.
- Step 4. Set the multimeter to the necessary settings to read 4 to 20 mA and connect it in series with the DC power supply, transmitter, and controller as shown in Figure 46.
- Step 5. Ideally, the transmitter should be calibrated at its factory-specified temperature range. For example, a 40 to 140 °F range transmitter will output 4 mA at the low-end value of its temperature range (40 °F) and 20 mA at its high-end value (140 °F).

In addition, the transmitter should output 12 mA at a temperature midway between the limits of its temperature range (90 °F) because the milliamp output is a linear function with respect to temperature.

The RTD simulator, decade box, or potentiometer may not be able to produce a resistance that corresponds to the desired temperatures. In this case, try to produce a resistance that is as close to the low-end value as possible without going less than the low-end value. Also, try to produce a resistance near the high-end value without going above the high-end value. For example, referring to Figure 47, the RTD simulator can produce a resistance corresponding to 25 and 50 °F. Do not use the 25 °F setting because this is below the

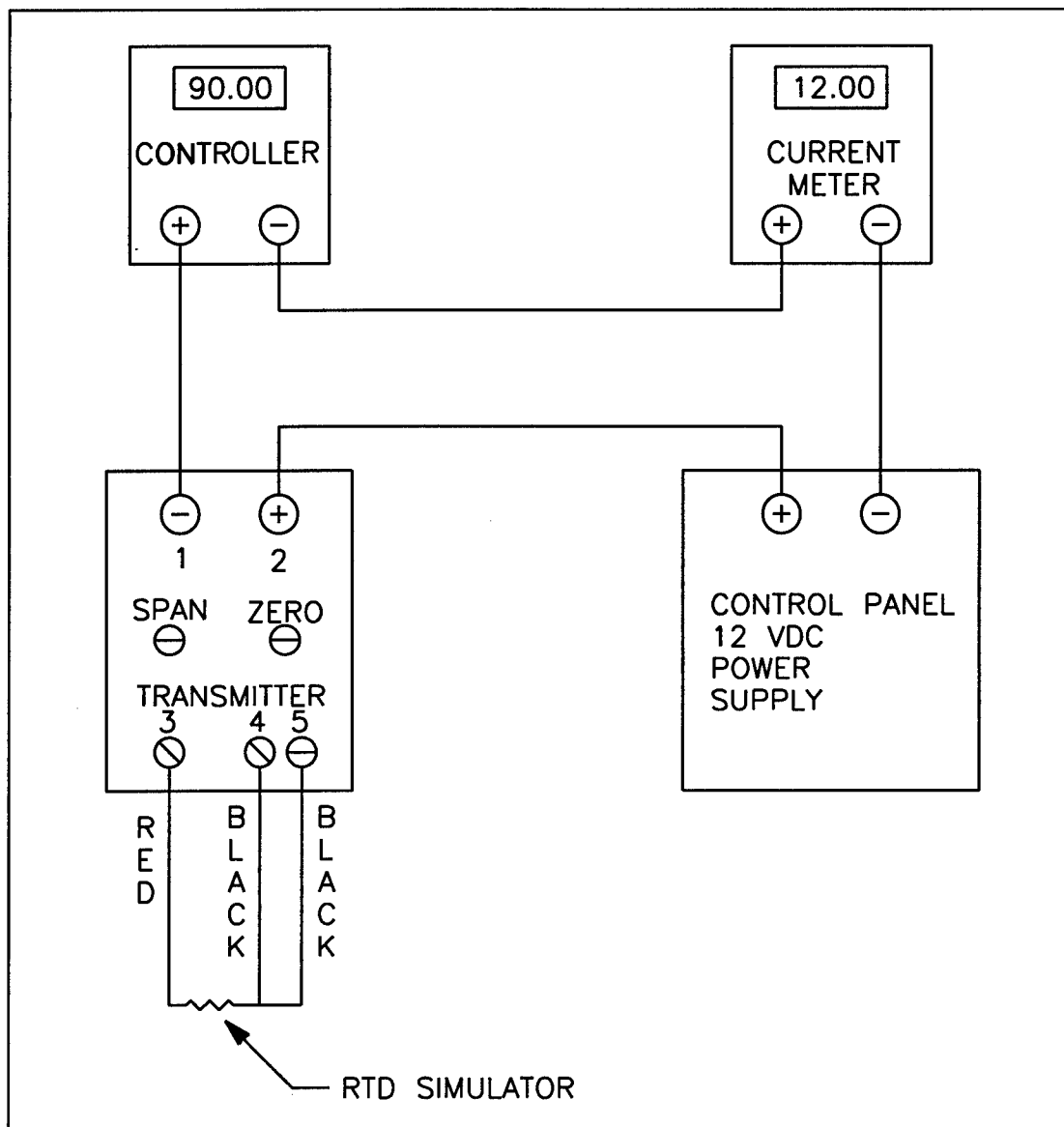

Figure 46. Calibration set-up for temperature circuit.

40 °F range limit. The 50 °F setting should be used. For the high-end, the 125 °F setting should be used. To check for transmitter linearity, for the mid-point, either the 75 or 100 °F setting can be used.

Referring to Appendix D, the corresponding resistance for a 100 ohm RTD at 50 °F would be 103.90 ohms, 114.68 ohms corresponds to 100 °F, and 120.03 ohms corresponds to 125 °F.

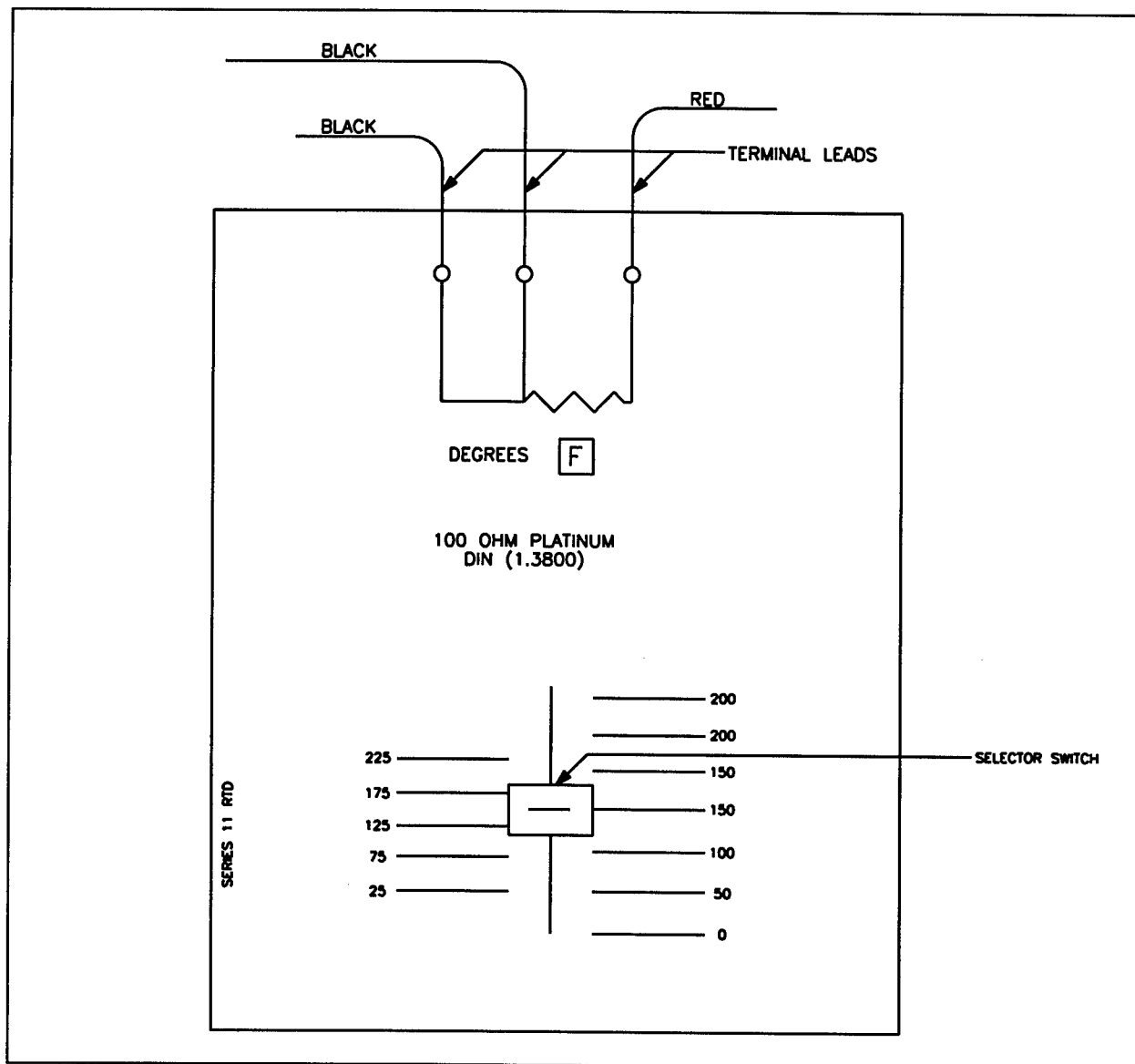

Figure 47. RTD simulator.

- Step 6. Set the RTD simulator or decade resistance box to the low-end value (50 °F). The milliamp output is determined by referring to Appendix C, or from the following equation:

$$I = \frac{(T_p - T_l) \times 16\text{mA}}{(T_h - T_l)} + 4\text{mA} \quad [\text{Eq 20}]$$

where: I = milliamp output, mA

T_p = test point temperature (50, 100, 125 °F)

T_l = low end of transmitter range, 40 °F

T_h = high end of transmitter range, 140 °F.

- Step 7. With the jeweler's screwdriver, turn the zero adjustment screw on the transmitter until the proper output is displayed on the multimeter (current meter) (5.6 mA).
- Step 8. After reaching the desired output, set the RTD or decade resistance box to the high-end setting (125 °F). Then turn the span adjustment screw on the transmitter until the desired output is displayed on the multimeter (current meter) (17.6 mA).
- Step 9. The adjustments affect both ends of the span, especially when the adjustments are not made at the range limits (40 °F and 140 °F), so it will be necessary to repeat steps 6 to 8 until the desired output is within 0.1 percent of the span (0.016 mA).
- Step 10. After completing the zero and span adjustments, set the RTD or decade resistance box to a mid-range value. Verify that the expected mid-range output value is obtained (13.6 mA). Because linearity is important to getting accurate readings in the midpoint area, the transmitter may have to be replaced if the midpoint value is off by more than 0.032 mA (2 °F).

Because many temperature processes operate around a certain temperature, the technician should attempt to accurately calibrate the transmitter in that range. For example, the discharge (supply) air temperature for a VAV cooling-only system should be operating around 55 °F; so during calibration of the transmitter the proper choice should be to concentrate on having an accurate output at 55 °F, rather than at the high and low ends.

TT Repair/Replacement. Generally, if a TT is found to be faulty, it may be best to replace the entire transmitter and RTD assembly. The technician may choose to replace only the transmitter or only the RTD, whichever is faulty. This is acceptable.

Differential Pressure Transmitter

Physical Description. The measurement of static pressure is accomplished using a differential pressure transmitter (DPT). Figure 48 shows the standard symbol for a duct static pressure transmitter. This arrangement is typical for sensing duct static pressure as the controlled process variable in a VAV system. The 4 to 20 mA output of the transmitter is the PV input to a duct static pressure controller used to control fan inlet vanes or fan speed. The probe labeled "H" is used to sense the static pressure in the duct; the probe labeled "L" is used to sense static pressure outside

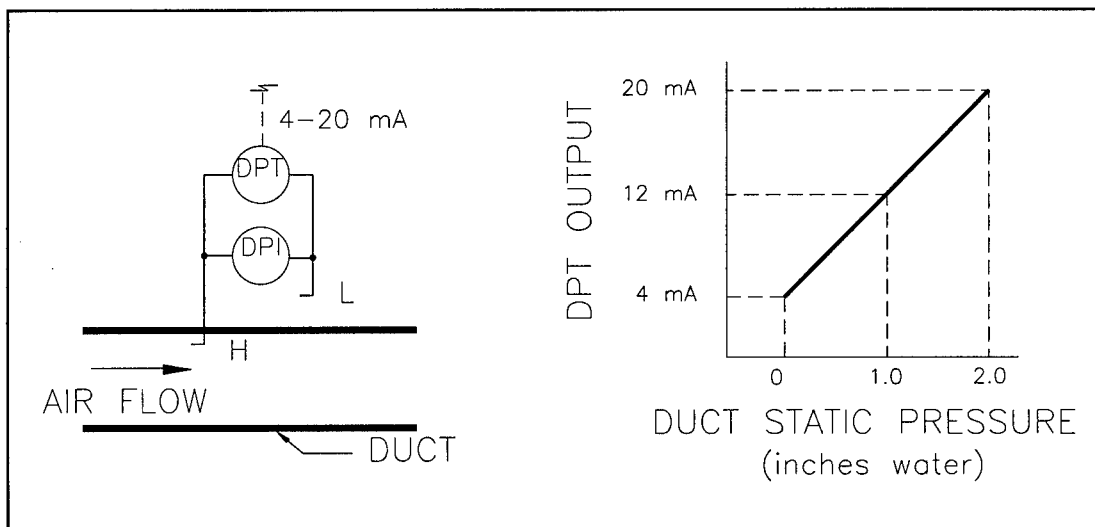

Figure 48. Standard symbol for duct differential pressure sensor and transmitter, and for linear input/output relationship.

the duct. The difference or differential between static pressures sensed at "H" and "L" are sensed by the sensing element integral to the DPT. DPI is a local differential pressure indicator or gage. The DPT converts the differential pressure to a signal within the range of 4 to 20 mA. The DPT output is linearly related to the sensed differential pressure as seen in Figure 48. The standard range for the DPT sensor is 0 to 2.0 in. of water column (iwc). As is the case with most other transmitters, the DPT must be a two-wire, loop-powered device.

DPT Problem Diagnosis and Troubleshooting. The differential pressure transmitter can be expected to be a low maintenance device. Problem diagnosis and troubleshooting steps are shown in Tables 7 and 8.

Similar to the TT, the relationship between the sensed static pressure and transmitter output is linear. The DPT output values for corresponding pressures can be determined from the tables in Appendix C, or calculated using the following equation:

$$I = \frac{((P_p - P_l) \times 16\text{mA})}{(P_h - P_l)} + 4\text{mA} \quad [\text{Eq 21}]$$

where I = milliamp output, mA

P_p = test point pressure, as measured from the field gage, iwc

P_l = low end of transmitter range, 0.0 iwc

P_h = high end of transmitter range, 2.0 iwc.

The equation simplifies to the following when the known values are inserted:

$$I = (Pp \times 8) + 4\text{mA} \quad [\text{Eq 22}]$$

DPT Calibration. DPT calibration procedures have been written in as much detail as possible while remaining generic enough to apply to any vendor's TT. Recalibration of the DPT may be required once a year. If the device requires calibration more often than this, it should be replaced.

- Calibration check. The procedure described in Tables 7 and 8 can be used to determine if the temperature transmitter is operating correctly.
- Calibration procedure. The purpose of calibrating a DPT is to obtain an accurate output from the transmitter for a specific static pressure. CEGS-15950 requires that the transmitter have zero and span screws for calibration. Typical calibration of a 0 to 2.0 iwc pressure transmitter follows, but the technician also should refer to the manufacturer's literature for product specific information.

The following equipment will be needed for the calibration procedure:

- digital multimeter
- small/jeweler's screwdriver
- "Transmitter mA Output Versus Process Variable Input Tables" (Appendix C)
- calculator (optional).

The following steps should be followed:

- Step 1. Apply a 0.0 iwc signal to the DPT. Measure the current output from the transmitter and adjust the zero screw if necessary to get a 4 mA signal.
- Step 2. Apply a 2.0 iwc signal to the DPT (exercise caution so as not to over-pressurize the transmitter!). Measure the current output from the transmitter and adjust the span screw if necessary to get a 20 mA signal. If a pressure source is not available, apply pressure by turning on the fan. Try to get the pressure as steady and close to 2.0 iwc as possible, and use the DPT equation to calculate what the mA output should be, then adjust the span to achieve this output.

- Step 3. Apply a 1.0 iwc signal to the pressure instrument to check linearity. Measure the current output from the transmitter, which should be 12 mA ± 0.32 mA. Determine what the setpoint of the static pressure (supply fan) controller is from the equipment schedule or other sources. If the static pressure in the supply duct generally will be operating around 1.0 iwc, recalibration procedures should attempt to ensure accurate values around 1.0 iwc rather than at the upper and lower ends.

DPT Repair/Replacement. DPTs have no user serviceable parts. If a DPT is found to be faulty, it should be replaced.

Relative Humidity Transmitters

Physical Description. The measurement of relative humidity is accomplished with a relative humidity transmitter (RHT). The two primary types of RHTs use solid state elements whose resistivity or capacitance varies directly with relative humidity. The RHT provides a 4 to 20 mA output that is linearly related to the relative humidity as shown in Figure 49. The standard control system ranges for relative humidity sensors are 0 to 100 percent and 20 to 80 percent RH. The output signal from the 0 to 100 percent transmitter should be 4 mA at 0 percent RH and 20 mA at 100 percent RH, with an accuracy of ± 5 percent (0.8 mA). The output signal from the 20 to 80 percent transmitter should be 4 mA at 20 percent RH and 20 mA at 80 percent RH, with an accuracy of ± 5 percent (0.48 mA).

RHT Problem Diagnosis and Troubleshooting. RHTs should be checked frequently to ensure that they are operating correctly. Problem diagnosis and troubleshooting steps are shown in Tables 7 and 8.

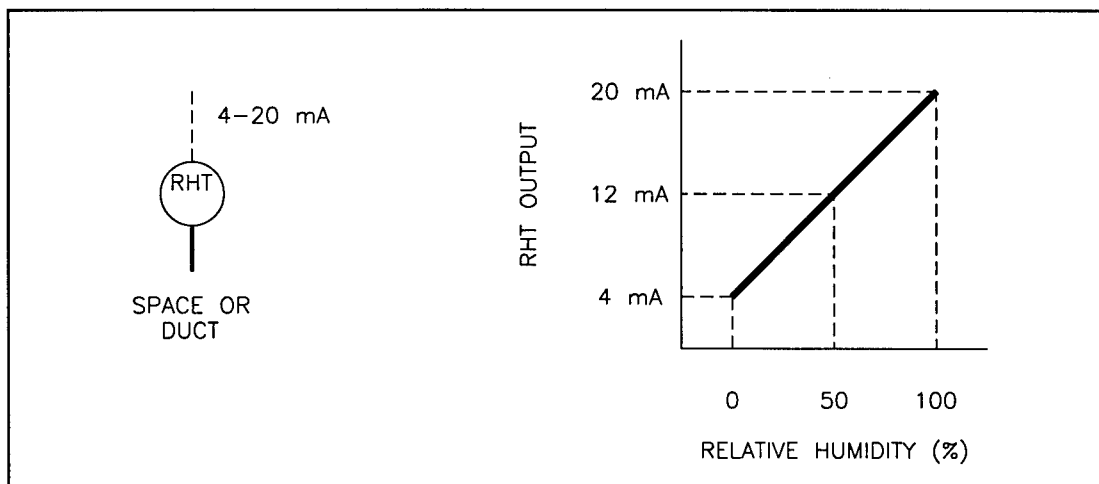

Figure 49. Standard symbol for space or duct relative humidity sensor and transmitter and linear input/output relationship.

Similar to the TTs, the relationship between the sensed relative humidity and the transmitter output is linear. The RHT output values for corresponding humidities can be determined from the tables in Appendix C or calculated using the following equation:

$$I = \frac{((H_p - H_l) \times 16)}{(H_h - H_l)} + 4 \quad [\text{Eq 23}]$$

where: I = current output in mA

H_p = test point humidity

H_l = low end of transmitter range (0 and 20 percent)

H_h = high end of transmitter range (100 and 80 percent).

The equation simplifies to the following when the known values are inserted for the 0 to 100 percent sensor:

$$I = (H_p \times 0.16) + 4 \quad [\text{Eq 24}]$$

The equation simplifies to the following when the known values are inserted for the 20 to 80 percent sensor:

$$I = ((H_p - 20) \times 0.267) + 4 \quad [\text{Eq 25}]$$

RHT Calibration. Recalibrating RHTs requires special equipment. Some manufacturers provide recalibration kits consisting of saturated salt solutions. Check with the manufacturer for availability of this kit or return the RHT to the manufacturer for recalibration.

RHT Repair/Replacement. In general, faulty RHTs should be replaced because it is less expensive than the time and effort to repair the unit. Some RHTs have replaceable sensing elements. Check with the manufacturer.

Airflow Measurement Arrays

Physical Description. An airflow measurement array (AFMA; also referred to as an airflow measurement station) is used to measure duct airflow rate. Two basic types are available: pitot tube and electronic. Electronic AFMAs may be further categorized as being either a hot-wire anemometer or a heated thermocouple anemometer.

Flow transmitters provide a 4 to 20 mA output signal proportional to the airflow rate in units of feet per minute. The output error of the transmitter shall not exceed 0.5 percent of the calibrated measurement. The standard symbol for an AFMA is shown in Figure 50. Unlike other transmitters, the AFMA transmitter is not loop powered. The AFMA station requires its own dedicated power source to power the station and transmitter.

As illustrated in Figure 51, both types of AFMA consist of straightening vanes and an array of velocity-sensing elements inside of a flanged sheet metal casing. Multiple velocity-sensing elements are distributed across the duct cross-section.

Electronic AFMAs are required to have an accuracy of ± 3.0 percent over a range of 125 to 2500 fpm. The standard range for an electronic AFMA is from 125 fpm to

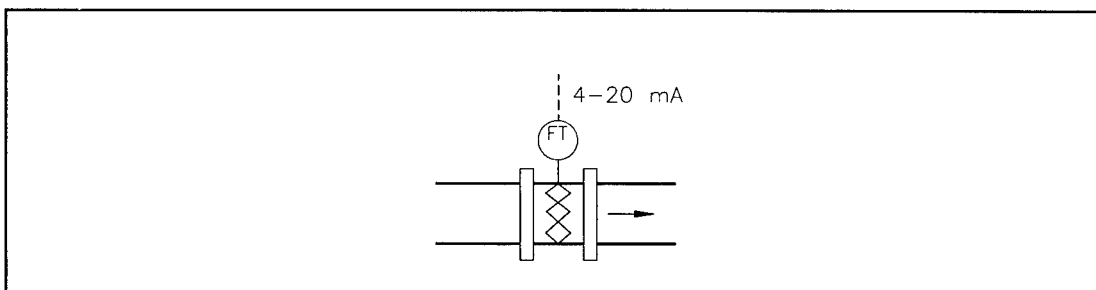

Figure 50. Standard symbol for an airflow measurement array and transmitter.

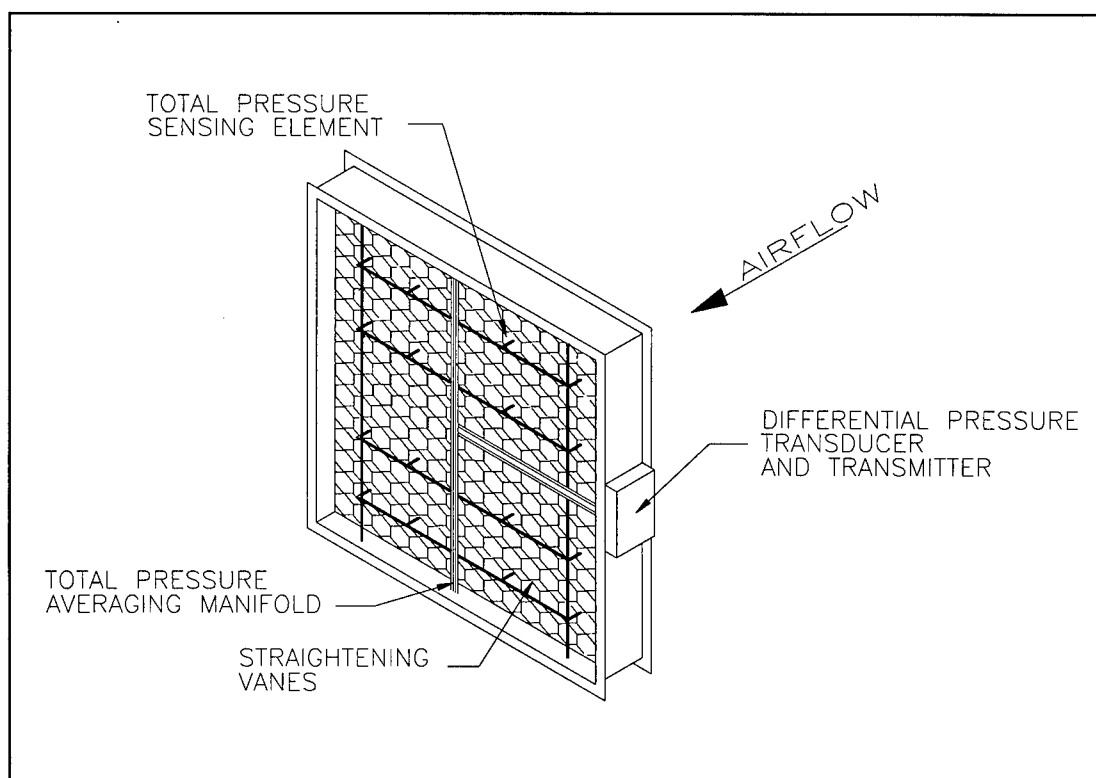

Figure 51. Typical pitot tube airflow measurement station.

2500 fpm. In addition, the velocity sensing elements of the electronic AFMA must be either an RTD or thermistor.

Pitot tube AFMAs are required to have an accuracy of ± 3.0 percent over a range of 700 to 2500 fpm. A pitot tube AFMA should not be used if the required velocity measurement is below 700 fpm. In addition, pitot tube AFMA transmitters are required to contain square root extraction circuitry to provide an output that is proportional to the airflow rate.

AFMA Transmitter Problem Diagnosis and Troubleshooting. AFMA units should be checked frequently to ensure that they are operating correctly. Note that the problem diagnosis and troubleshooting steps shown in Tables 7 and 8 do not apply to the AFMA because, unlike other transmitters, the AFMA transmitter is not loop powered. Because AFMA stations require their own power source, there are few troubleshooting steps that can be taken. These steps include:

- Check the AFMA wiring for loose connections or reverse polarity.
- Ensure that the controller configuration parameters are set properly to recognize the range of the AFMA device. The range of the controller must be set to the range of the flow being measured, in units of cfm. The AFMA transmitter signal is in units of feet per minute (refer to the tables in Appendix C). Therefore the PV high range of the controller must be set to:

$$\text{PV high} = \text{duct area (ft}^2\text{)} \times \text{high range of AFMA fpm}$$

$$\text{PV high} = \text{maximum cfm}$$

- If the AFMA signal is connected to the CPA (remote setpoint) input of the controller, make sure the controller is operating in the remote setpoint mode. This may be accomplished by pushing the remote setpoint button on the front of the controller or setting of the appropriate configuration parameter.

AFMA Transmitter Calibration. Although AFMA transmitters sometimes have zero and span screws for calibration, field recalibrating the AFMA requires special equipment and facilities. These transmitters should be sent to a lab or returned to the manufacturer for recalibration.

AFMA Repair/Replacement. AFMAs have no user serviceable parts. If an AFMA is found to be faulty, it should be replaced.

Positive Positioners

Physical Description. A positive positioner (PP) is a type of pneumatic relay mounted directly on a pneumatically actuated valve or damper. It accepts a pneumatic control signal input and provides a pressure signal output to the actuator to position the valve or damper. The PP precisely positions the valve or damper according to the pneumatic control signal and eliminates valve/damper hysteresis, regardless of the load variations affecting the valve stem or damper shaft. PPs are required to have an adjustable starting point and operating range. The starting point adjustment is used to establish the value of the control air pressure signal at which the positioner will begin to move the actuator. The operating range adjustment dictates the range of the pneumatic control signal over which the actuator will move full stroke.

As shown in Figure 52, the control pressure signal exerts a downward force on the lever to the left of the pivot causing the lever to rotate slightly counter-clockwise. This causes the NC supply air "ball" to be pushed open and allows the NC exhaust air "ball" to be pushed closed by its spring. Supply air passes to the actuator, causing the actuator shaft to move down. The movement of the shaft pulls on the linkage spring, exerting a downward force on the right end of the lever, thus an upward force on the left end of the lever. When this force increases enough to equal the force of the control air pressure signal, the supply air "ball" closes. With a decrease in the control air pressure signal, the NC exhaust "ball" opens until the forces balance.

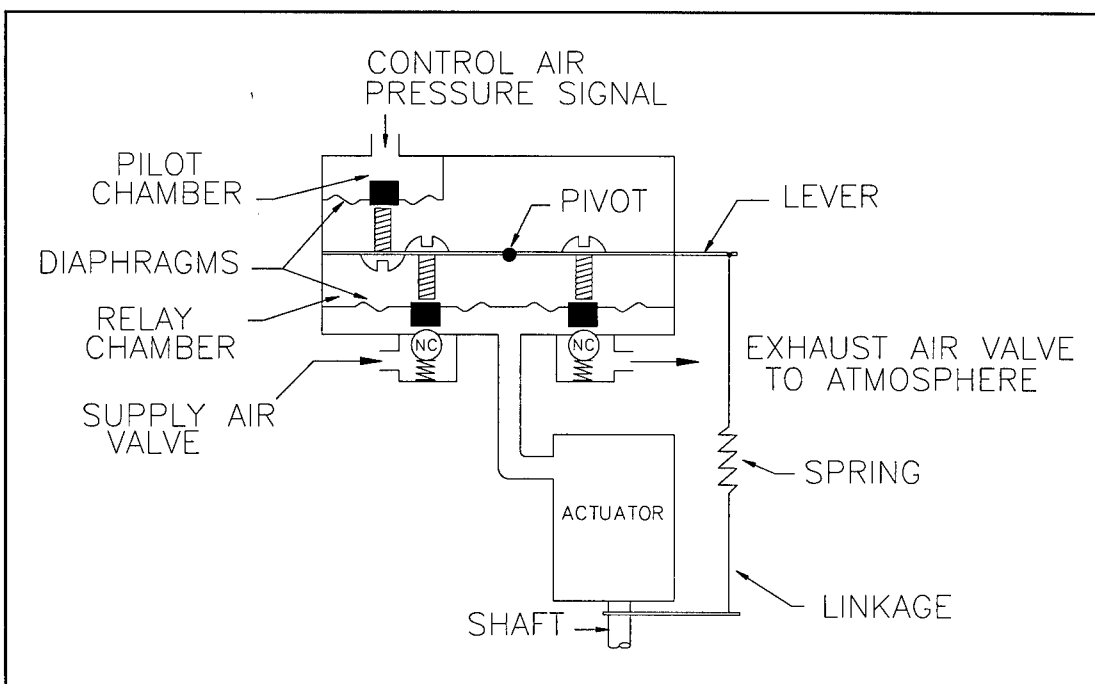

Figure 52. Positive positioner schematic.

Figure 53 shows a PP applied to a damper. The PP moves the actuator in proportion to the control air pressure signal. The spring provides feedback to the positioner on the actual position of the damper shaft. If the connected shaft is not at the required position or the load tries to move the shaft from the required position, the positioner will exhaust or supply main air to the actuator in response to the feedback spring as necessary to correct the condition. The result is more rapid and precise control under varying operating conditions.

The pressure signal range over which an actuator moves full stroke is dictated by its spring range. Typical spring ranges are 3 to 8 psig and 8 to 13 psig. To accommodate standard application requirements, a PP is used to accept a 3 to 15 psig control signal input and cause the actuator to move full stroke over any desired range of pressures regardless of the spring range of the actuator. Assume that a given actuator has a spring range of 8 to 13 psig, and the available control signal ranges between 3 and 15 psig. The positioner, mounted on the actuator, can be adjusted to move the actuator full stroke over a range of 3 to 15 psig instead of the 8 to 13 psig spring range of the actuator. Adjusted differently, the PP will provide full stroke actuation over a range of 4 to 10 psig, or 8 to 15 psig, or 3 to 15 psig, etc.

The starting point and operating range adjustments of PPs are useful to sequence multiple actuators. For example, in a particular application, the 3 to 15 psig control signal may be used to modulate both heating and cooling coil valves. The spring range of both valve actuators may be 8 to 13 psig. The PP on each actuator can be adjusted so the heating coil actuator moves full stroke in response to the 3 to 9 psig portion of the control signal, and the cooling coil actuator moves full stroke in response to the 9 to 15 psig portion of the control signal. This avoids simultaneous heating and cooling.

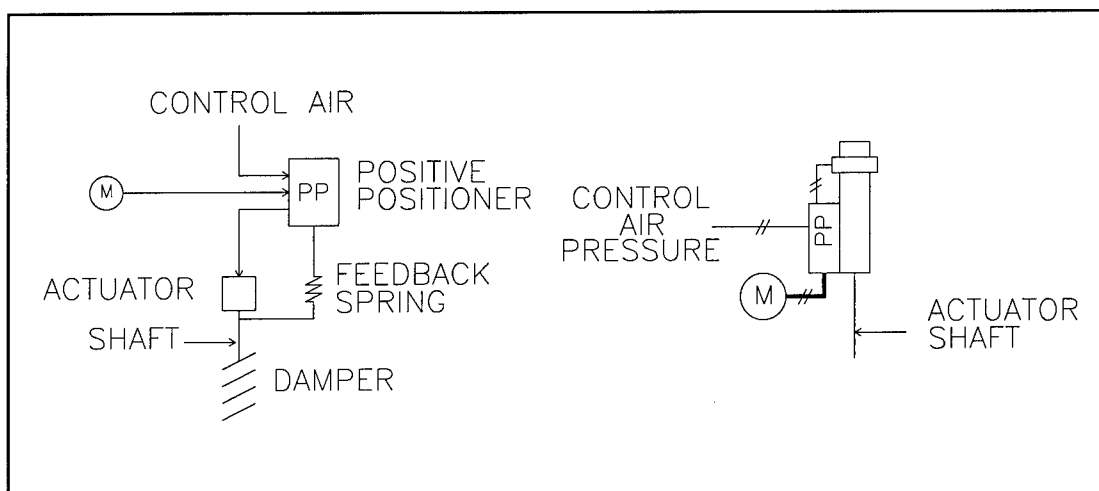

Figure 53. Positive positioner (PP) applied to a damper, and the standard symbol for a PP.

PP Calibration/Adjustment. The zero and span adjustments for the PP adjustment presented here may vary from manufacturer to manufacturer. Consult the manufacturer's adjustment procedures. This example also presumes that the PP is being adjusted for a 3 to 15 psig range. The required range depends on the application and should be shown on the equipment schedule.

- Step 1. Adjust the output of the controller to 4 mA so the output of the IP transducer is 3 psig. The technician may want to confirm that a 3 psig signal is present at the PP by placing a gage in the pneumatic line at the positive positioner.
- Step 2. Adjust the zero screw on the PP until the device which is being actuated is in its normal position (normally closed or open).
- Step 3. Adjust the output of the controller to 20 mA so the output of the IP transducer is 15 psig.
- Step 4. Adjust the span screw on the PP until the device being actuated moves full range (fully open for a normally closed valve).

Function Modules and Other Control Devices

General. Function modules are devices that are used to supplement the control functions performed by single-loop controllers. Function modules are essentially control devices that accept a current input signal (4 to 20 mA) and produce a modified current output (4 to 20 mA) signal or a contact-type output signal. In addition to function modules, there are other control loop components—termed control devices and accessories—that are required as part of the standard control systems. The various function modules and control devices and accessories are:

- minimum position switch (MPS)
- temperature setpoint device (TSP)
- signal inverter (INV)
- high/low signal selector (TY or RHY)
- sequencer module (SQCR)
- current Loop driver (LD)
- relays or time delay relays (R or TDR)
- time clock (CLK)
- current-to-pneumatic transducer (IP)
- regulated DC power supply.

Most of these devices accept a 4 to 20 mA signal input(s) and provide a 4 to 20 mA output(s). All of the devices listed, except the IP, are powered from an external source of between 110 and 120 VAC. Basic descriptions of these hardware items follow.

Minimum Position Switch. This function module is used in mixed air temperature control applications. It provides a constant analog output signal within the range of 4 to 20 mA. A potentiometer dial on the front of the module is used to set the output signal level. The pot setting establishes the output signal used to set the minimum position of the outside air damper. The dial on this module will have graduations. Graduation or setting resolutions vary in that the pot may be single-, partial single-, or multiple-turn. Most applications will require a single- or partial single-turn pot, although in some instances a multiple-turn pot may be necessary.

Temperature Setpoint Device. This function module is identical to the minimum position switch, although its application is different. This module is used to provide a steady 4 to 20 mA signal for CPA of a single-loop controller. Examples include night setback and temperature low limit applications. The setpoint range of the device is established by the controller and is equivalent to the configured PV range (or span) of the controller. The controller also can limit the upper and lower ends of the setpoint. For example, if the controller is configured to a span of 0 to 100 °F, the 4 to 20 mA signal from the temperature setpoint device must be scaled to correspond to this temperature range. If it is desired to limit the range of adjustment to 50 to 80 °F, these limits can be configured into the controller.

Signal Inverter. This function module inverts a 4 to 20 mA signal. A 4 mA input is inverted to a 20 mA output. Likewise, a 20 mA input yields a 4 mA output. Signal inputs within this range are proportioned accordingly. The simplest way to express this function mathematically is:

$$\text{Output} = 24 - \text{Input}$$

High/Low Signal Selector. This function module comes in two forms: either as a high signal selector or as a low signal selector. Both accept multiple 4 to 20 mA inputs. The high signal selector compares these inputs and provides an output signal equivalent to the highest input. The low signal selector compares the inputs and provides an output signal equivalent to the lowest input. Typically, the output is electrically isolated from the inputs.

Sequencer. This function module provides for a sequencing of one or more contact closures from an input signal. For example, it can provide step loading/unloading

of an air conditioning condensing unit in response to the input signal to the sequencer. All contacts are returned to their zero input signal condition when power is interrupted.

Loop Driver. Due to the inherent characteristics of single-loop controllers used in the standard systems, the connected circuit in the controller's output loop should have an input impedance no greater than 600 ohms. This does not present a problem for most applications. However, in some applications when a single controller sequences the operation of several valves or dampers, the 600 ohm limit can be exceeded. A loop driver can be placed in the output circuit of the controller. The loop driver function module has an input circuit impedance of 100 ohms or less, but it has sufficient output capacity to drive a circuit with an impedance of at least 1000 ohms. The loop driver will provide a current output identical to its input.

A secondary benefit of most loop drivers is that they provide electrical isolation between the input and the output signals. This can be useful in applications when the input signal has a different ground reference than the output signal.

Relays. CEGS-15950 requires all relays to be of the double-pole, double-throw (DPDT) type. Figure 54 shows a functional illustration of a DPDT relay. It is shown in its normal (de-energized) state. Separate input signals can be applied to each of the two poles. There also are two outputs, one for each input. Each output has two throws (output contacts), shown as A and B. When the solenoid is energized (115 to 120 VAC power applied) the relay contacts switch to route the input signals to the A output contacts. With no power applied to the solenoid, the relay is de-energized, the relay contacts are spring returned to their normal positions, and the input signals are routed to the B output contacts. Some applications may warrant the use of time delay relays (TDR). These are functionally similar to the DPDT relay described here, except they must delay for a fixed-time period after being energized

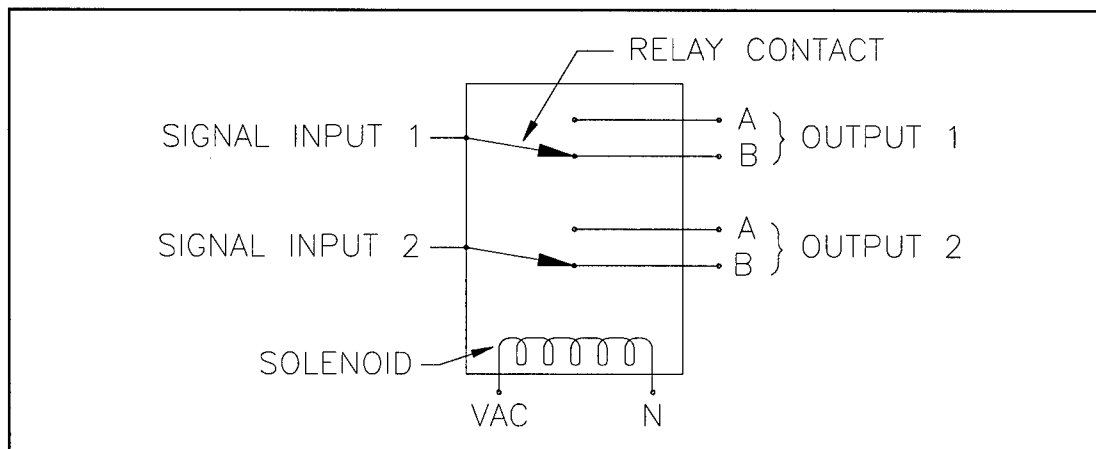

Figure 54. Double-pole, double-throw (DPDT) relay.

or de-energized before the relay contacts change state. The fixed-time period is adjustable from 0 to 3 minutes.

Time Clock. A time clock is a digital device used to control the modes of operation of the control panel. It has a keypad and an alphanumeric digital display on the face of the unit. The keys are used primarily to configure the device, but they also may be used to interrogate it for information concerning its configuration or present mode of operation. Configuration usually consists of defining the times and dates that its contact closure outputs will be open and/or closed. It has the capability of accepting information for a 365-day time period (including holidays) and can be configured to adjust for standard and daylight savings time. The configured information is stored in nonvolatile memory.

Current-to-pneumatic Transducer. An IP converts a 4 to 20 mA signal to a 3 to 15 psig pressure signal. CEGS-15950 requires IPs to be two-wire devices. A two-wire IP is powered by its 4 to 20 mA input signal as opposed to being powered from a separate power source. They are field-reversible. This feature permits the IP to be switched on-site to provide a 15 to 3 psig output versus a 3 to 15 psig output in response to a 4 to 20 mA input. Typically, IPs receive a current input signal from a controller and provide a pneumatic output to modulate an actuator.

Regulated DC Power Supply. The control panel's DC power supply is required to provide 24 VDC. It is used as the power source for all local control transmitters interfaced with the control panel. Its amperage rating is 2 amps, but it is not to be loaded with more than 1.2 amps.

Electronics

Ohm's Law. CEGS-15950 requires that all electronic I/O devices (electric actuators, function modules, IPs, etc.) accept a 4 to 20 mA input and provide a 4 to 20 mA output. Before describing the various electrical connections, an understanding of Ohm's Law is required. As will be described later, Ohm's Law is a powerful tool in troubleshooting and diagnosing control panel malfunctions.

Ohm's Law describes the relationship between current (I), voltage (V), and resistance (R) in an electrical circuit:

$$I = \frac{V}{R} \text{ or } V = I \times R \text{ or } R = \frac{V}{I} \quad [\text{Eq 26}]$$

The first form of Ohm's Law, shown here, is the most useful in the standard control systems. Let us consider an application of the first form.

Assume we have a control loop that appears to be malfunctioning. The symptom is the controller display shows that the temperature reading is high, so we suspect the TT might be bad. Using a thermometer to measure the actual temperature, we determine that the display should indicate 50 °F. We check the posted drawings and see that the TT range is 0 to 100 °F; therefore, the sensor should be transmitting a 12 mA signal (the midpoint between 4 and 20 mA). You could remove a wire from the PV input to the controller and measure the actual current to see if it is 12 mA, or you could more quickly measure the voltage across the PV+ and PV- terminals (without removing any wires and risking shorting something out) and use Ohm's Law to determine the current. Given that we know the input resistance (internal resistor) to the controller is 250 ohms (from tables in Appendix B) we can use Ohm's Law with this resistance (250 ohms) and the measured voltage (3.0 VDC) to determine the current:

$$I = \frac{V}{R}$$

$$I = \frac{3.0 \text{ VDC}}{250 \text{ ohms}} = 0.012 \text{ amps} = 12 \text{ mA} \quad \text{[Eq 27]}$$

Control Loop Circuit. A control loop circuit consists of the various interconnected control devices. A typical control loop circuit wiring diagram is shown in Figure 55. In the controller's input loop, the TT is powered by a DC power supply. The TT provides a signal within the range of 4 to 20 mA to the SLDC PV input. In the output loop, the controller sends a 4 to 20 mA signal to the I/P transducer, which in turn sends a pressure signal to an actuator.

Standard Input And Output Loops. Most SLDC act on a DC input voltage signal. In practice, this is often accomplished by passing the transmitter's 4 to 20 mA output current through a resistor internal to the controller or connected across the controller's input terminals. The value of this resistance is considered the input resistance of the controller.

For the standard control loops shown in TM 5-815-3, matching the input resistance of the controller with the output power of the transmitter should not be a significant concern. The reason for this is that almost all commercially available transmitters provide sufficient output power to drive at least one controller or device, and there are no standard applications for which a transmitter is used to drive more than one controller or device.

Most SLDCs power the output loop. CEGS-15950 requires this for standard controllers. This means that the 4 to 20 mA signal is generated from a power supply within the controller as illustrated in Figure 55. The output resistance through which the controller must supply its 4 to 20 mA signal is represented by the input resistance (R) of the I/P transducer. SLDCs have output load resistance ratings indicating the maximum output loop resistance through which they can supply a full 20 mA. In selecting the type and quantity of devices to be placed in the controller output loop, caution must be exercised to avoid exceeding the controller's output load resistance rating. CEGS-15950 requires that single-loop controllers be capable of driving a minimum of 600 ohms. This is sufficient to drive two devices, and in no instance should this limit be exceeded.

Loop-Powered Devices. Several of the standard control loop devices are loop-powered. A loop-powered device receives its power to operate from a power supply or sourcing device in series with the loop-powered device. A loop-powered transmitter receiving its power from a series power supply can be seen on the input loop side of Figure 55. A loop-powered I/P receiving its power from a sourcing controller can be seen on the output loop side of Figure 55.

An identifying characteristic of a loop-powered device is that it has only two wiring connections. This is in contrast to a nonloop-powered device that has at least four wires, two of which are connected to a power source such as 120 VAC. In general, transmitters and I/Ps are loop-powered devices.

Transmitter Operation. A variety of transmitters are used in the standard systems. These include temperature, relative humidity, airflow, and differential pressure

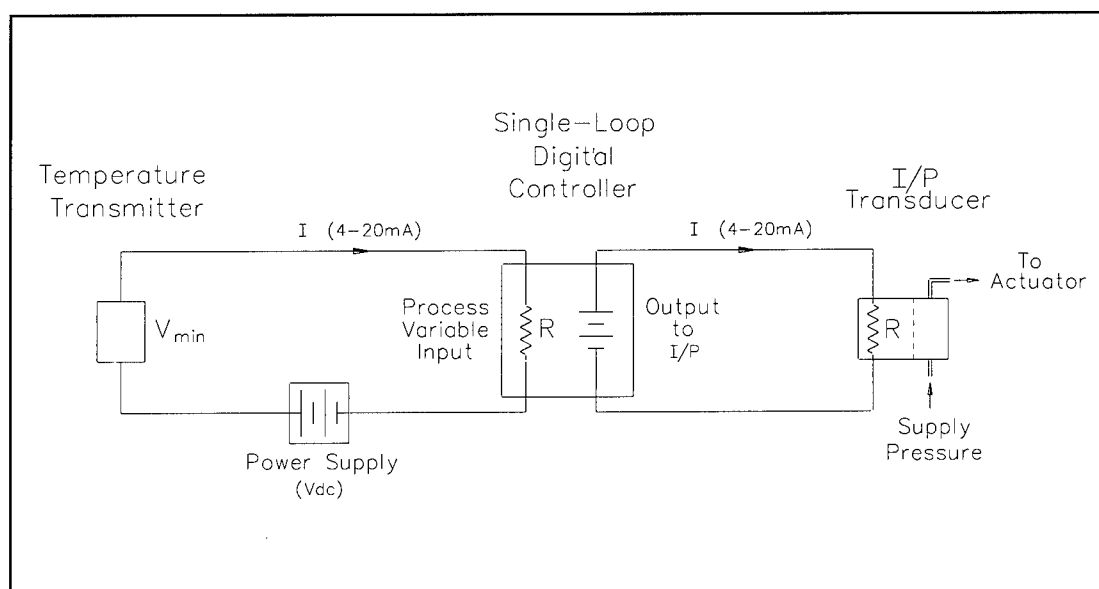

Figure 55. Typical control loop wiring.

transmitter. Most of these are loop-powered. A loop-powered transmitter requires a minimum voltage to be available to it in order for it to operate. This minimum voltage is sometimes called the liftoff voltage and typically is 12 VDC. This is illustrated in Figure 55 where V_{\min} is the liftoff voltage for a typical transmitter.

The graph in Figure 56 is similar to that usually provided by the transmitter manufacturer. The DC power supply voltage is on the horizontal axis and the corresponding transmitter maximum output loop resistance is on the vertical axis. Figure 56 illustrates how the maximum output resistance is constrained by the size of the external DC voltage power supply used to power the transmitter. The larger the power supply the greater the resistance through which the transmitter can provide a full 20 mA signal. When the voltage of the power supply connected to the loop-powered transmitter is equal to V_{\min} , the resistance connected to the transmitter output loop through which the transmitter can provide a full 20 mA is 0 ohms. In this instance, the transmitter will not work. If the power supply voltage is equal to V_{\max} , the transmitter can provide a full 20 mA to a resistance of R_{\max} . R_{\max} might be as high as 2000 ohms for a particular transmitter. Figure 56 is a graphical illustration of Ohm's Law:

$$\text{current (I)} = \text{voltage (V)}/\text{resistance (R)}$$

Applying this to the loop-powered transmitter:

$$I = (V_{PS} - V_{\min})/R \quad [\text{Eq 28}]$$

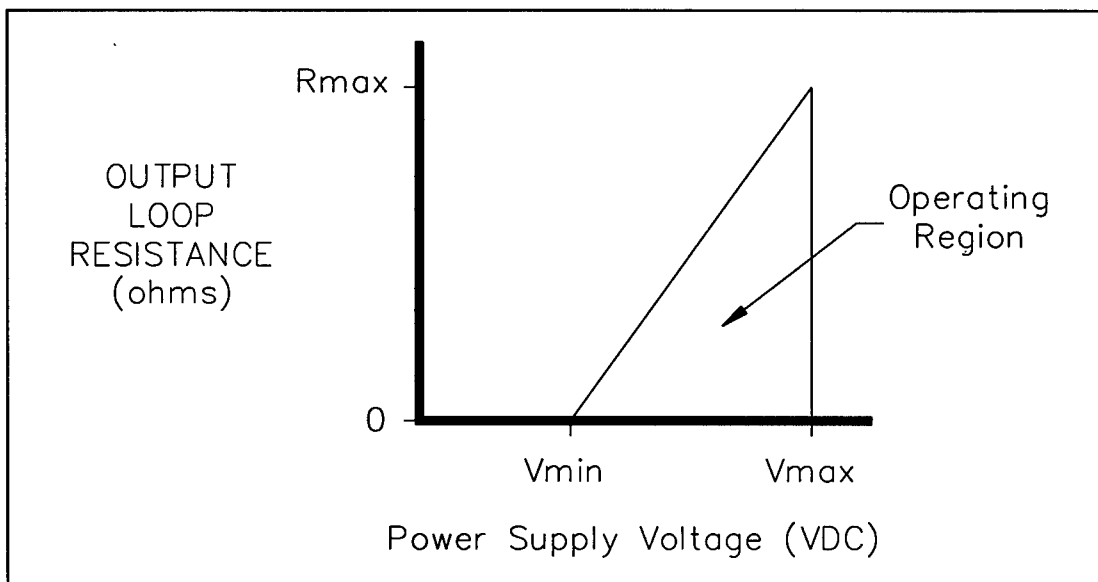

Figure 56. Transmitter range of operation.

where:

V_{PS} = power supply voltage, VDC

V_{min} = transmitter liftoff voltage, VDC.

This equation is practically applied by rearranging it and substituting in some known constraints. One known constraint is the power supply voltage, V_{PS} , which is 24 VDC per CEGS-15950 requirement. The other known constraint is the maximum current, 20 mA, that will flow through the circuit. Using this information and assuming that the liftoff voltage, V_{min} , is 12 VDC, one can determine the maximum resistance (R_{max}) of the device(s) connected to the output loop of the transmitter:

$$R_{max} = (V_{PS} - V_{min})/I \quad [\text{Eq 29}]$$

$$R_{max} = (24 - 12)/0.020 = 600 \text{ ohms} \quad [\text{Eq 30}]$$

Nonloop-Powered Devices. In contrast to a loop-powered device, a nonloop-powered device is externally powered, usually from 120 VAC. Several function modules are not loop-powered. These include the minimum position switch, signal inverter, high signal selector, sequencer module, and loop drivers and are discussed in more detail later in this section.

Function Modules. As mentioned previously, most function modules are not loop powered. The only exceptions are IPs. Because these modules are not loop powered, they are externally powered from a separate power source such as 120 VAC. The reason for the external power requirement is that they perform tasks which are fairly complex and thus have a large power draw due to the extensive circuitry contained within them. Because function modules are externally powered, they also power their output loop. Function modules are required by CEGS-15950 to have an input resistance that does not exceed 250 ohms. Because of this constraint, the standard controller can drive up to two function modules in the controller output loop.

The loop driver function module is externally powered and can drive up to a 1000 ohm output load resistance. Loop drivers have a characteristic input resistance that is less than 100 ohms. It is useful in an application when more than two devices are required in a controller output loop. In this type of application, only one of the devices and a loop driver function module should be connected directly to the controller output. The other two devices should be connected to the loop driver

output. Use of the loop driver is illustrated in the controller TC XX-01 output loop in Figure 57.

Loop drivers also are useful in an application with a relay contact in the control loop circuit. The driver can be used to isolate the contact from other devices in the circuit so, when the contact is open, current can still flow through to the other devices in the circuit. This also is illustrated in Figure 57.

Figure 57 illustrates the two typical applications of the loop driver. In Figure 57A the output signal from controller (TC) is applied to three IPs. Because of impedance limitations, the controller does not have sufficient power to send a 20 mA signal to three devices. Therefore, a loop driver must be used as in Figure 57B. The controller signal is sent to one IP and to a loop driver. The loop driver in turn sends an output signal, identical to its input, to the other two loop drivers in the circuit.

Figure 57C shows that the output from the controller must be received by the IP and the signal selector (TY). Assume that the purpose of the relay contact is to prohibit the controller signal from reaching the TY in a particular control mode but the IP must always receive the control signal. In 57C, when the relay contact is open, the control signal output from the TC loses its ground (at TY), thus no signal is received by either the TY or the IP. Figure 57D shows how to correct this situation using a loop driver so, when the contact is open, IP still receives the signal from TC.

Input and Output Loop Variations. TM 5-815-3 contains specific standard control loop configurations. These configurations should not cause problems. However, in special applications or modifications, it may be necessary to modify the design of a standard loop or design a loop from scratch. Proper performance of special application control loops can be ensured by observing the following guidelines and constraints:

- relay contacts must be isolated from the circuit using a loop driver
- control panel DC power supply = 24 VDC
- function module input resistance = 250 ohms
- transmitter output resistance = 600 ohms
- controller input resistance = 250 ohms
- controller output resistance = 600 ohms
- loop driver input resistance = 100 ohms
- loop driver output resistance = 1000 ohms
- resistance of 18 gage copper wire = 6.4 ohms per 1000 ft.

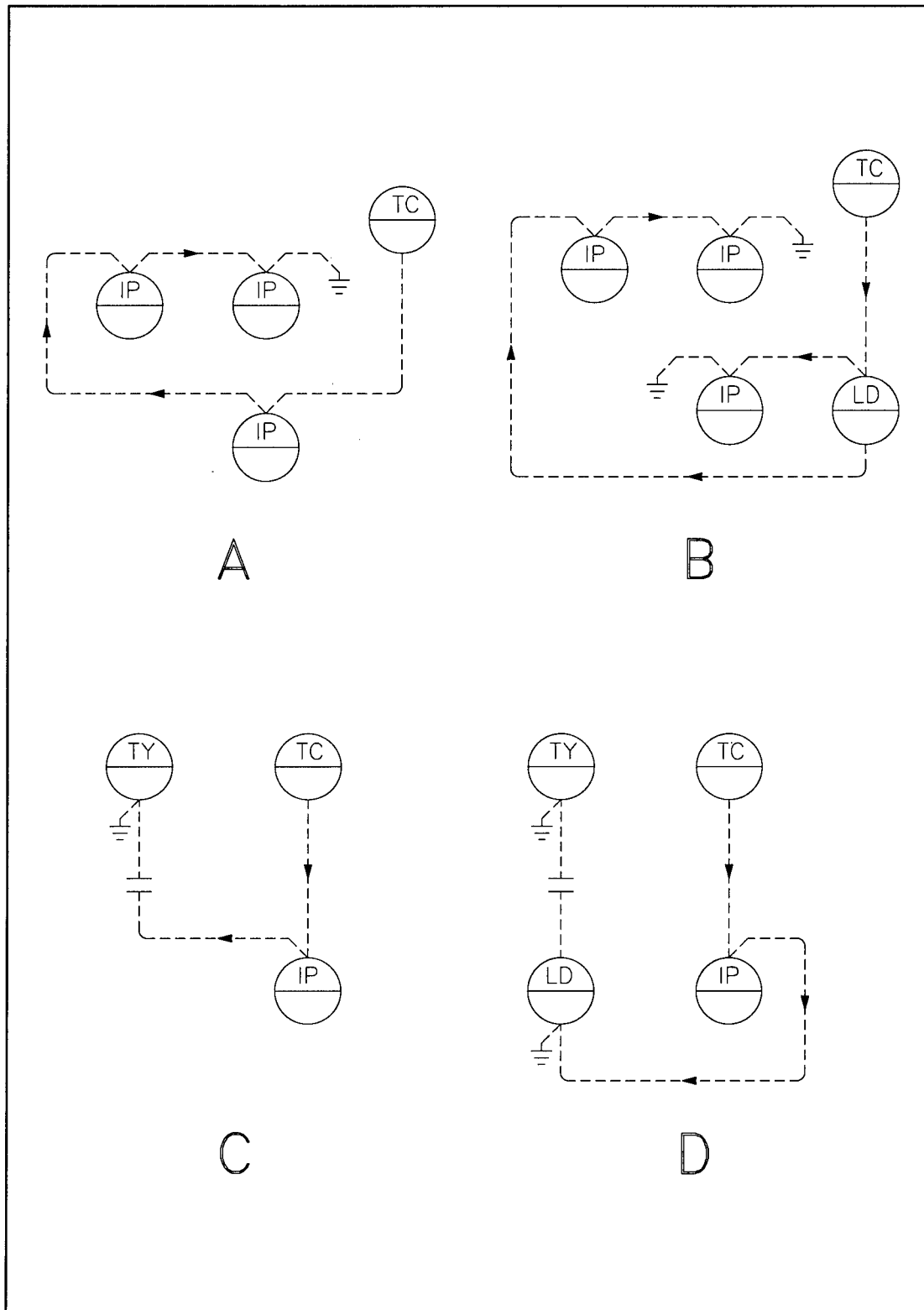

Figure 57. Typical loop driver applications.

Methods for Calculating Output Resistance. To better understand I/O resistance-matching concepts, the following discussion is provided. In Figure 58, the 4 to 20 mA signal from a TT is used as an input to two different controllers. To ensure the TTs ability to supply a full 20 mA through the output loop load resistance imposed by the two controllers requires consideration of the electrical characteristics of the transmitter and the total resistance of the loop ($R_1 + R_2$). It is safe to assume that the TT requires a liftoff voltage (V_{min}) of 12 VDC. We know that the control panel power supply provides 24 VDC (V_{PS}). The maximum loop resistance ($R_1 + R_2$) through which a transmitter can supply 20 mA can be calculated using:

$$R_1 + R_2 = (V_{PS} - V_{min}) / 0.020 \text{ mA} \quad [\text{Eq 31}]$$

$$R_1 + R_2 = 600 \text{ ohms} \quad [\text{Eq 32}]$$

if $R_1 = R_2$, the input resistance of each controller cannot exceed 300 ohms.

Figure 59 illustrates a situation in which the load resistance in a controller's output loop should be checked. Here the controller is required to drive two IPs. It must provide sufficient output power to produce a full 20 mA signal so the actuators, through the IPs, may be driven full stroke. In the example, the controller's output load resistance rating (R_L) must exceed the series combination of the IP transducer resistances (R_1 and R_2):

$$R_L > R_1 + R_2 \quad [\text{Eq 33}]$$

This method of computing output resistance differs from the preceding method because the power source used to drive the controller output is internal to the controller.

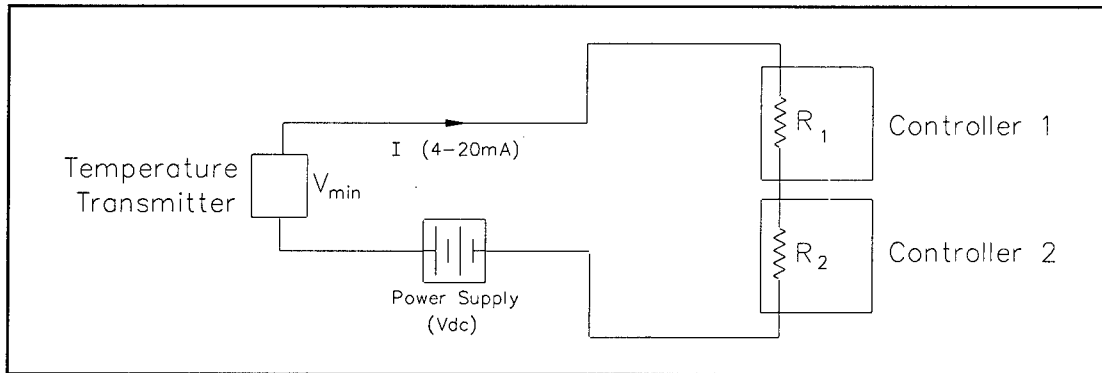

Figure 58. Transmitter loop output load resistance.

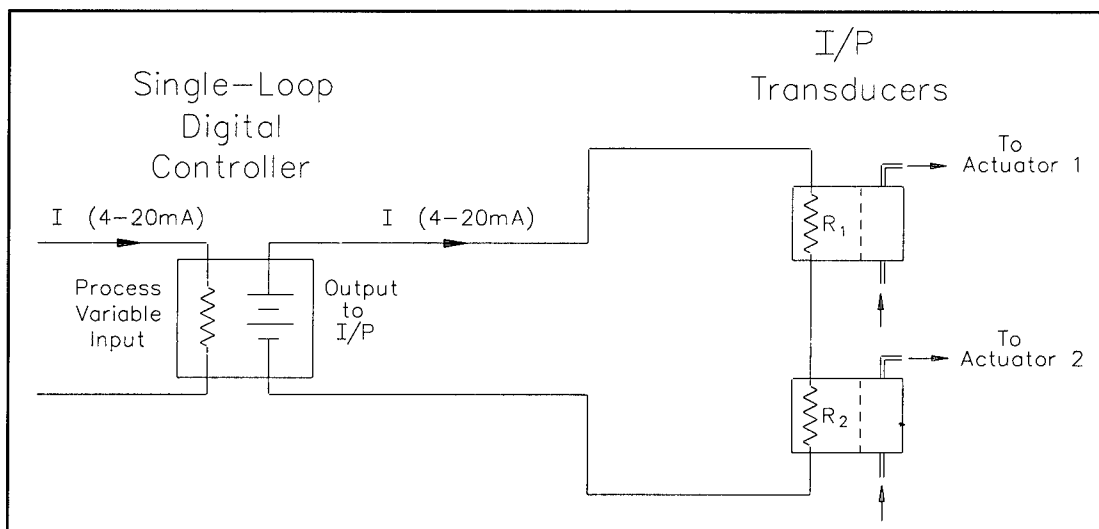

Figure 59. Controller output loop load resistance.

8 Preventive/Recurring Maintenance and Safety

Maintenance

Experience indicates that the standard control panels and hardware require little maintenance. But, certain preventive measures will help to ensure that the control panels remain as trouble free as possible, including:

- Reconfigure the Time Clock. The time clock operates on a 365-day schedule. It should be reconfigured annually to include the upcoming year's holidays and standard/daylight savings time. As a less maintenance intensive alternative, the time clock can be configured in a manner similar to the older style mechanical time clocks. To do this, configure the clock for a seven day per week schedule that ignores holidays. This alleviates the need to reconfigure the time clock annually. Refer to the clock operators manual to determine if standard/daylight savings time is automatically adjusted by the clock. If not, configure the clock for AM overlap so that the systems turns on an hour early during daylight savings time.
- Replace the Time Clock Battery. Some time clocks use 9 volt batteries to retain the configuration parameters in memory. Replace the battery annually or as needed.
- Check the accuracy of all sensors and PPs as described in the maintenance section of this report.

Safety

Operation and maintenance personnel are advised that the standard control panels contain 115 VAC circuits on the back side of the control panel inner door and on the back panel inside the control panel. Care should be exercised whenever the inner door of the control panel is open.

9 Summary

Standardized techniques and procedures for O&M of HVAC control panels and hardware for the U.S. Army Corps of Engineers are given in this report.

Extensive field experience at Fort Hood and other installations with standard control panels, systems, and equipment and in-lab experience provided tests of the procedures. The requirements for HVAC systems in CEGS-15950 and TM 5-815-3 were used as guidelines for the recommended procedures, and excerpts from other Corps material (e.g., PROSPECT course) were followed when applicable.

This report is recommended for use as a training aid and as a reference source for O&M personnel.

References

Cited

Corps of Engineers Guide Specification [CEGS]-15950, *Heating, Ventilating and Air Conditioning (HVAC) Control Systems* (Headquarters, U.S. Army Corps of Engineers [HQUSACE], Washington, DC, July 1990).

Engineering Technical Letter (ETL) 83-1, *Design of Control Systems for HVAC* (Headquarters, USAF/LEEEU, Washington, DC, 16 February 1983).

Technical Manual [TM] 5-815-3, *Heating, Ventilating and Air Conditioning (HVAC) Control Systems* (Headquarters, Department of the Army [HQDA], Washington, DC, 24 July 1991).

Uncited

American Society of Heating, Refrigerating and Air-Conditioning Engineers, *ASHRAE Handbook, 1985 Fundamentals* (American Society of Heating, Refrigerating and Air-Conditioning Engineers [ASHRAE], Atlanta, GA, 1984).

Chamberlin, G.A., and D.M. Schwenk, *Operation and Maintenance of Standard HVAC Control Systems*, Facilities Engineering Applications Program [FEAP]-UG-FE-94/19 (U.S. Army Center for Public Works, Fort Belvoir, VA, September 1994).

Chamberlin, G.A., and D.M. Schwenk, *Standard HVAC Control Systems Commissioning and Quality Verification User Guide*, FEAP-UG-FE-94/20 (U.S. Army Center for Public Works, Fort Belvoir, VA, September 1994).

Chamberlin, G.A., and V.L. Storm, *Demonstration of Standard HVAC Single-Loop Digital Control Systems*, FEAP-TR-FE-93/05/ADA265372 (U.S. Army Engineering and Housing Support Center, Fort Belvoir, VA, January 1993).

Clifford, G.E., *Heating, Ventilating and Air Conditioning* (Reston Publishing Company, Inc., Reston, VA, 1984).

Dickson, D.K., and S.T. Tom, "Economizer Control Systems," *ASHRAE Journal* (September 1986), pp 32-36.

Gupton, G.W., *HVAC Controls: Operation and Maintenance* (The Fairmont Press, Inc., Lilburn, GA, 1987).

- Haines, R.W., *Control Systems for Heating, Ventilating, and Air Conditioning*, 4th ed. (Van Nostrand Reinhold Co., New York, NY, 1987).
- Rowe, W.H., III, *HVAC Design Criteria, Options, Selections* (R. S. Means Company, Inc., Kingston, MA, 1988).
- Schwenk, D.M., D.L. Herron, and V.E. Alessi, *Standard Single-Loop Digital Controllers for HVAC Systems*, Technical Report [TR] E-90/14/ADA228326 (U.S. Army Construction Engineering Research Laboratories [USACERL], September 1990).
- Schwenk, D.M., J. Miller, and G.A. Chamberlin, *Standard HVAC Control Systems Retrofit Users Guide*, FEAP-UG-FE-94/18 (U.S. Army Center for Public Works, Fort Belvoir, VA, September 1994).
- Stoecker, W.F., and P.A. Stoecker, *Microcomputer Control of Thermal and Mechanical Systems* (Van Nostrand Reinhold Co., Inc., New York, NY, 1989).

Abbreviations and Acronyms

| | |
|------|--|
| AC | alternating current |
| AFMA | airflow measurement array |
| cfm | cubic feet per minute |
| CPA | control point adjustment |
| CPW | Center for Public Works |
| DC | direct current |
| DEV | deviation |
| DIR | direct |
| DPDT | double-pole, double-throw (type) |
| DPI | differential pressure indicator |
| DPT | differential pressure transmitter |
| EMCS | energy monitoring and control system |
| fpm | feet per minute |
| H/C | heating coil |
| HVAC | heating, ventilating, and air conditioning |
| I/O | input/output |
| IC | integral mode constant |
| IP | current-to-pneumatic transducer |
| ISA | Instrument Society of America |
| iwc | inches of water column |
| mA | milliamps |
| MR | manual reset |
| O&M | operation and maintenance |
| OUT | output |

| | |
|----------|---|
| PB | proportional band |
| PI | proportional-integral or pressure indicator |
| PID | proportional-integral derivative |
| PP | positive positioner |
| PROM | programmable read-only memory |
| PROSPECT | Proponent Sponsored engineer Corps Training |
| psi | pounds per square inch |
| psig | pounds per square inch gage |
| PV | process variable |
| PVT | performance verification test |
| RAM | random-access memory |
| REV | reverse |
| RHT | relative humidity transmitter |
| ROM | read-only memory |
| RSP | remote setpoint |
| RTD | resistance temperature device |
| SLDC | single-loop digital controller |
| SS | sensor span |
| TC | temperature controller |
| TCX | Technical Center of Expertise |
| TT | temperature transmitter |
| USACE | U.S. Army Corps of Engineers |
| VAC | voltage AC |
| VAV | variable air volume |
| VDC | volts DC |

Appendix A: Standard Control Symbols

Standard Symbols

THIS SECTION CONTAINS THE SYMBOLS THAT WILL BE USED FOR HVAC CONTROL-SYSTEM DRAWINGS PRODUCED IN ACCORDANCE WITH THIS TECHNICAL MANUAL.

EACH SYMBOL WILL BE REFERENCED TO A UNIQUE IDENTIFIER, WHICH WILL USE THE FOLLOWING FORMAT:

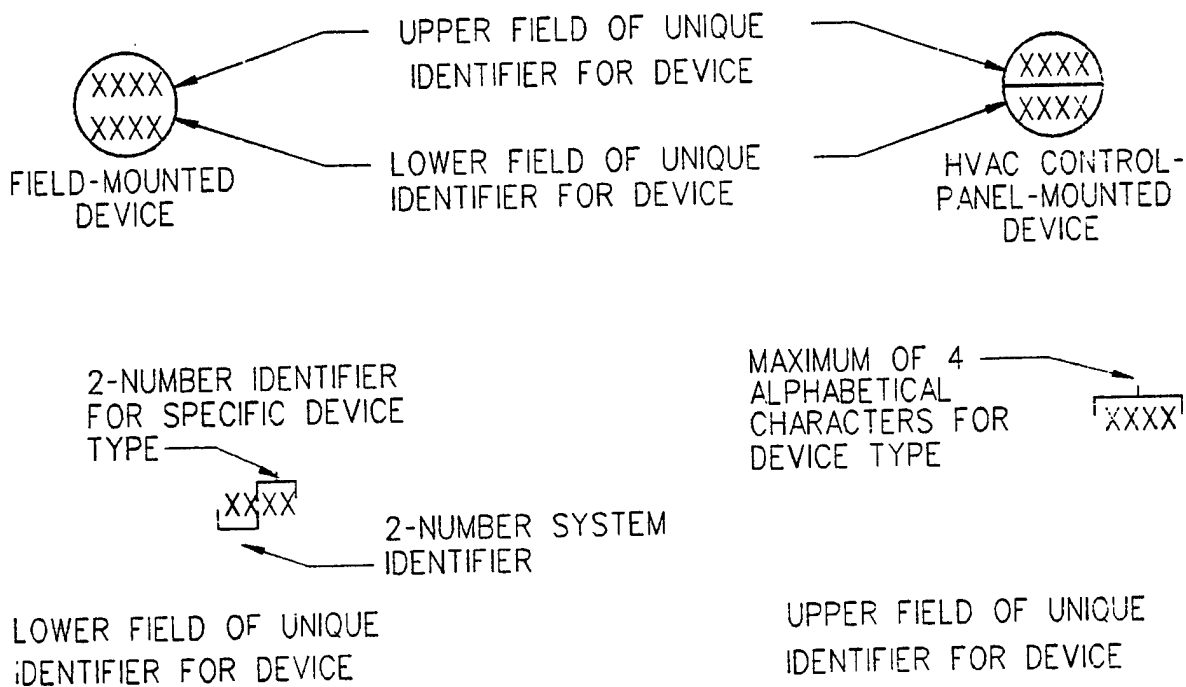

SCHEMATICS FOR HVAC CONTROL SYSTEMS WILL USE THE FOLLOWING SYMBOLS TO SHOW AIR FLOW AND ITS DIRECTION.



TYPICAL DUCT SYMBOL SHOWING AIR FLOW DIRECTION.

STANDARD REPRESENTATION OF AIR FLOW TO AND FROM CONDITIONED SPACE

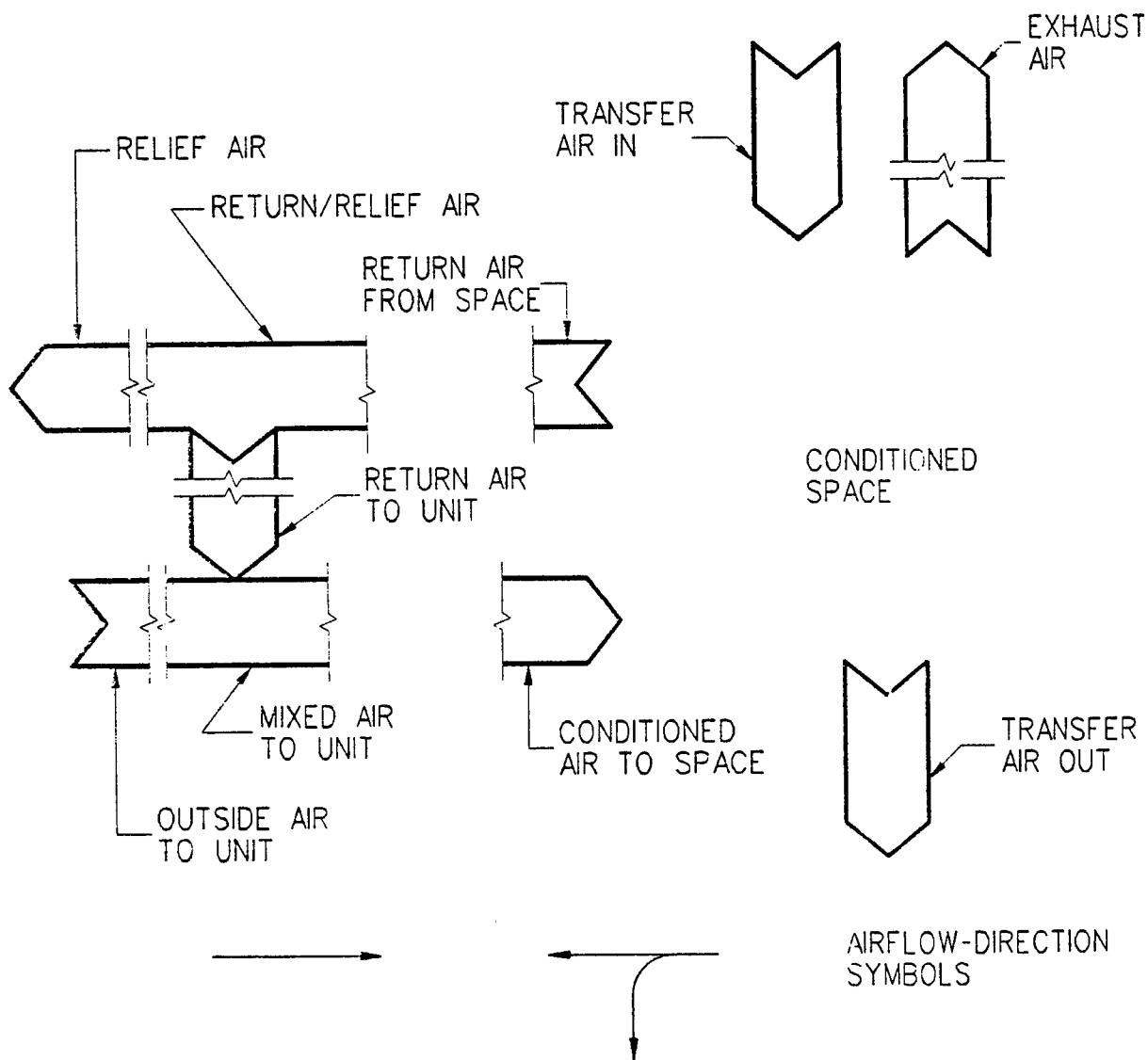

INSTRUMENTATION AND CONTROL-DEVICE SYMBOLS FOR HVAC
CONTROL-SYSTEM DRAWINGS ARE AS FOLLOWS:

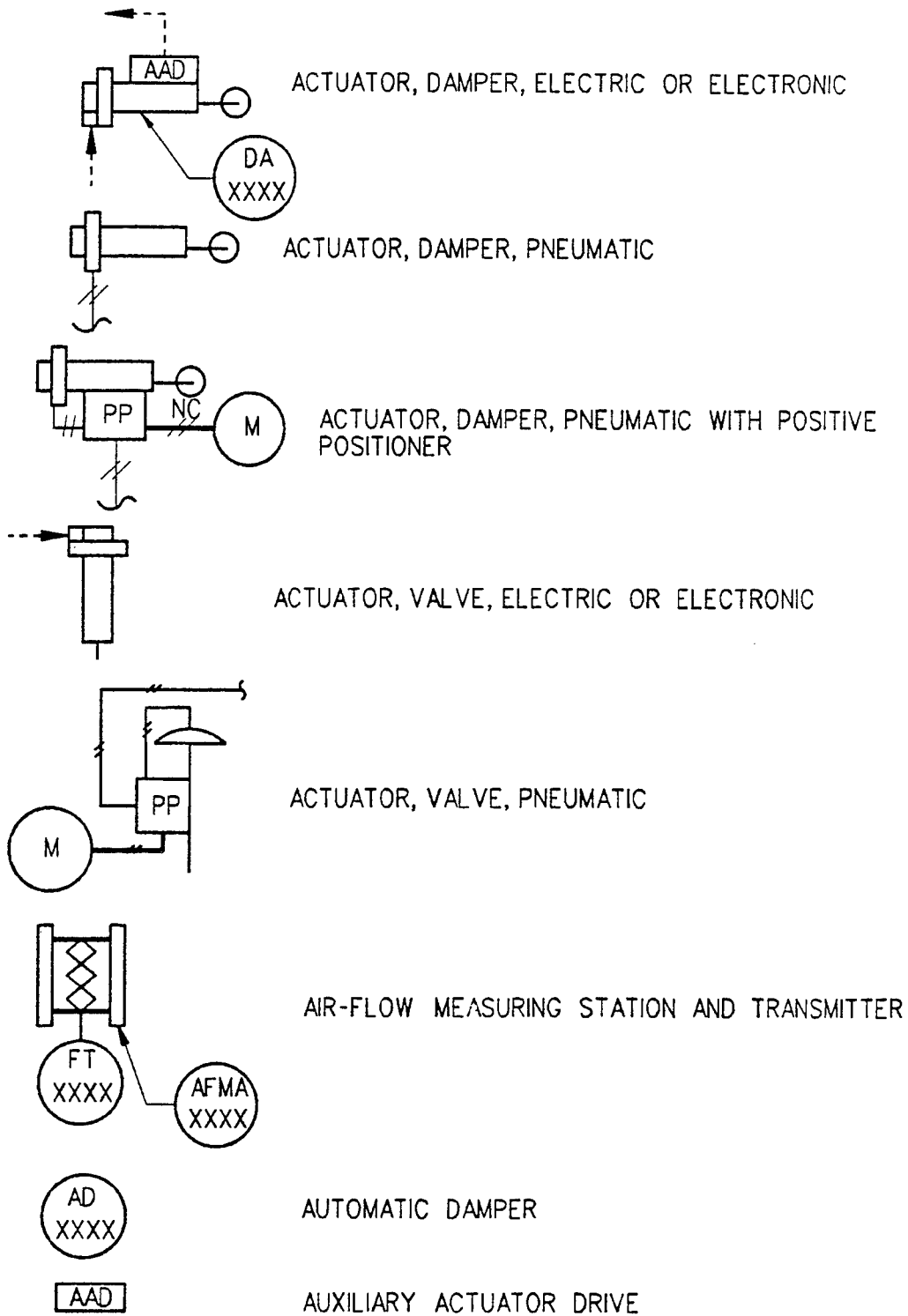

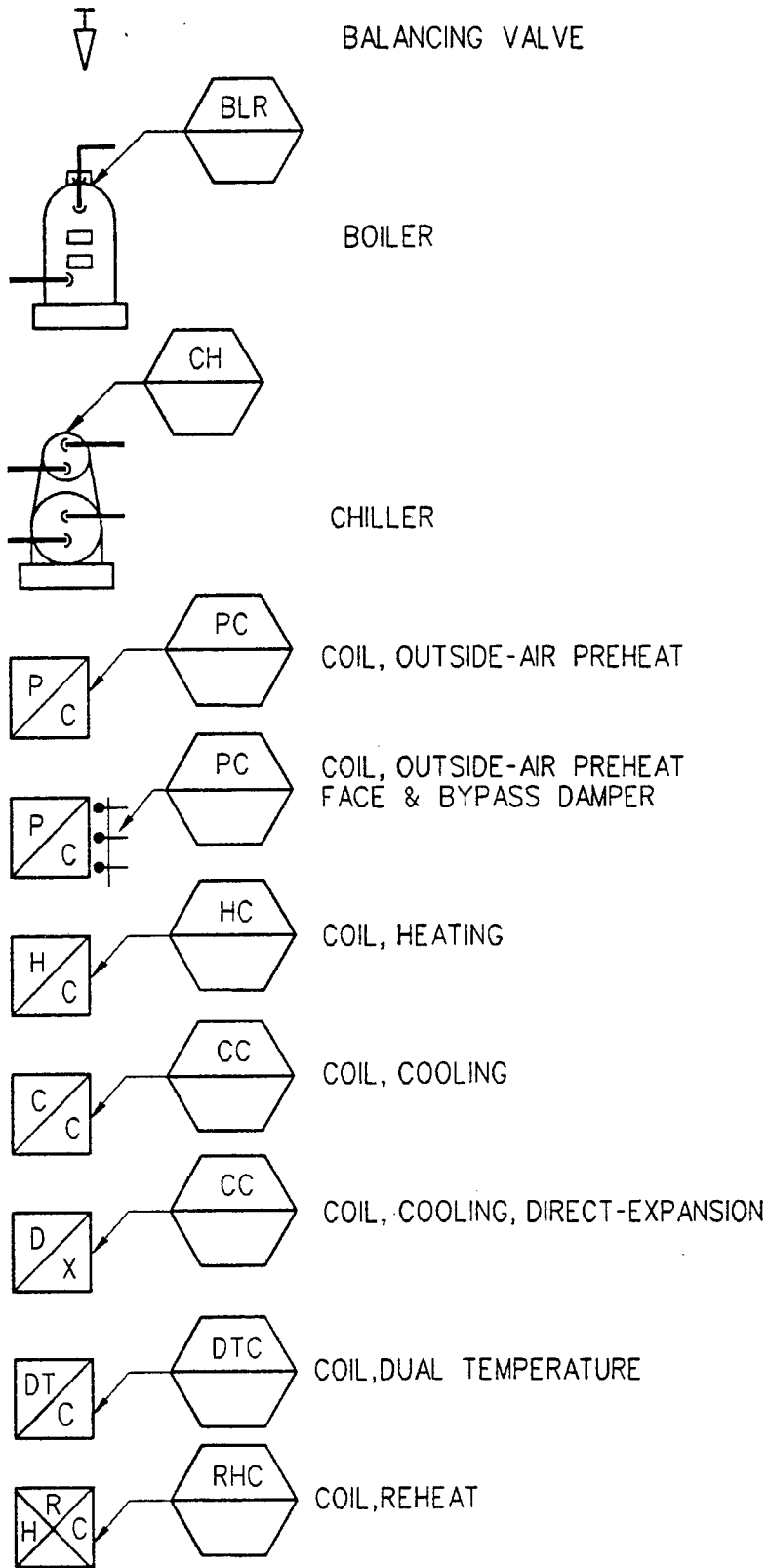

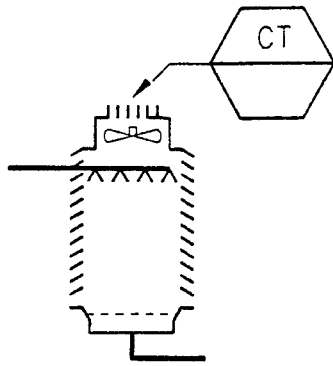

COOLING-TOWER CELL

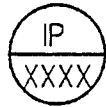

CURRENT-TO-PNEUMATIC TRANSDUCER



DAMPER, OPPOSED-BLADE WITHOUT SEALS



DAMPER, OPPOSED-BLADE WITH SEALS



DAMPER, PARALLEL-BLADE WITHOUT SEALS



DAMPER, PARALLEL-BLADE WITH SEALS



DEVICE SYMBOL, FIELD-MOUNTED

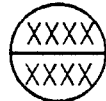

DEVICE SYMBOL, PANEL-MOUNTED



DIFFERENTIAL-PRESSURE INDICATOR



DIFFERENTIAL-PRESSURE SWITCH



DIFFERENTIAL-PRESSURE TRANSMITTER

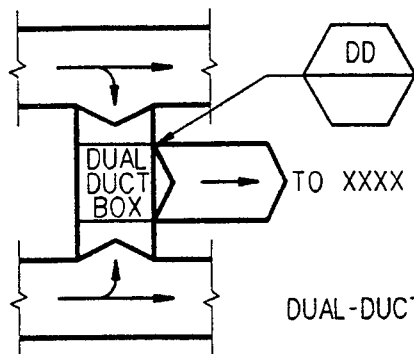

DUAL-DUCT BOX, CONSTANT VOLUME



ECONOMIZER CONTROLLER



ELECTRIC-SOLENOID-ACTUATED PNEUMATIC VALVE



ELECTRIC LINES (LADDER DIAGRAMS AND SCHEMATICS)



ELECTRONIC SIGNALS (SCHEMATICS)



END SWITCH

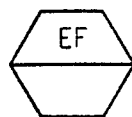

EXHAUST FAN



FAN

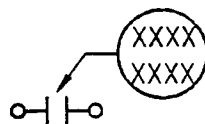

FIELD-DEVICE CONTACT



FIELD-DEVICE TERMINAL

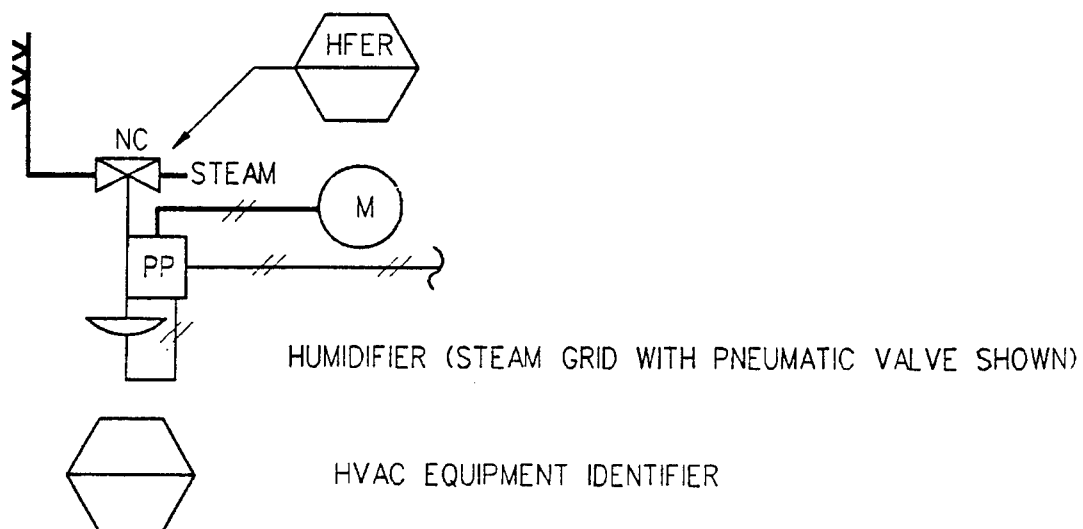
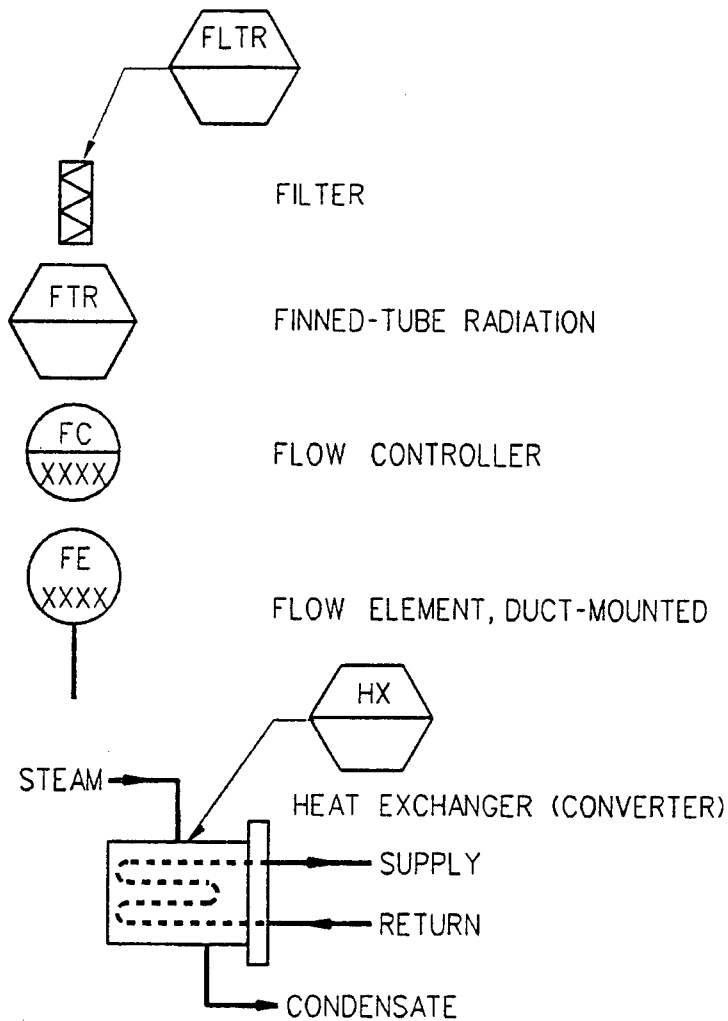

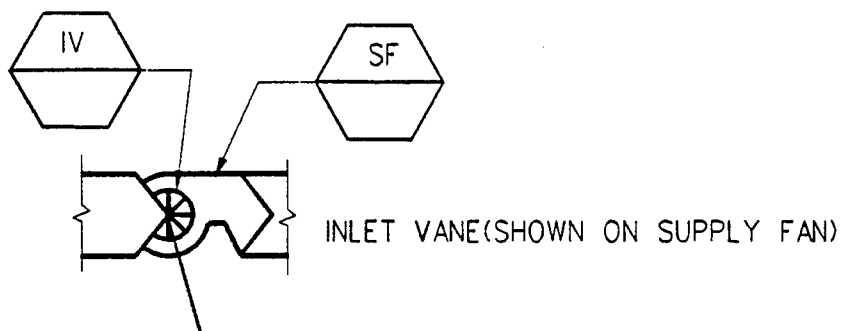

LOOP DRIVER



MAGNETIC-STARTER CIRCUIT BREAKER



MAGNETIC-STARTER CONTROL-CIRCUIT FUSE



MAGNETIC-STARTER CONTROL-CIRCUIT TRANSFORMER



MAGNETIC-STARTER HOLDING COIL

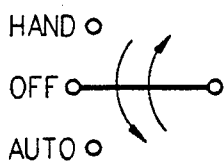

MAGNETIC-STARTER LOCAL CONTROL SWITCH

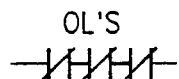



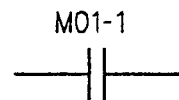



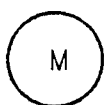

MAGNETIC-STARTER OVERLOADS

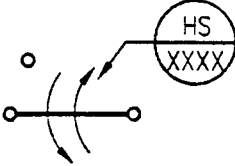

MAGNETIC-STARTER POWER CONTACT

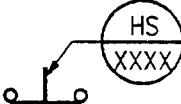

MAIN AIR

| | |
|---|---|
|  | MAIN AIR LINE |
|  | MAINTAINED-CONTACT INTERLOCKED SWITCHES |
|  | MANUAL TEMPERATURE-SETPOINT DEVICE |
|  | MANUAL VALVE |
|  | MICROPROCESSOR-BASED SPACE THERMOSTAT |
|  | MINIMUM-POSITION SWITCH |
|  | MODULATING DUCT THERMOSTAT, NON-AVERAGING |
|  | MODULATING SPACE THERMOSTAT |
|  | MODULATING THERMOSTAT, AVERAGING |
|  | MOMENTARY SWITCH |

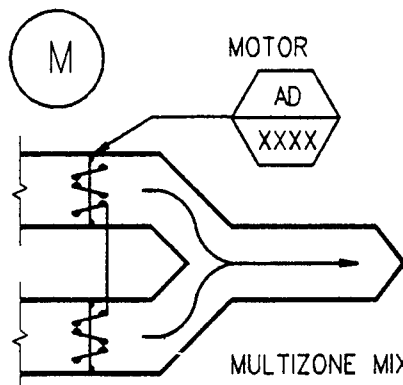

NIGHT THERMOSTAT, NON-MODULATING
SPACE THERMOSTAT, (BREAKS CONTACT
ON TEMPERATURE RISE)



NON-MODULATING SPACE THERMOSTAT,
(MAKES CONTACT ON TEMPERATURE RISE)



NON-MODULATING SPACE THERMOSTAT, OR AQUASTAT
(MAKES/BREAKS CONTACTS ON TEMPERATURE RISE)

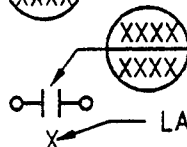

PANEL-DEVICE CONTACT

LADDER-DIAGRAM LINE



PILOT LIGHT

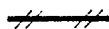

PNEUMATIC LINE (MAIN AIR)

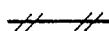

PNEUMATIC LINE (CONTROL)



POSITIVE POSITIONER



PRESSURE CONTROLLER



PRESSURE-SWITCH CONTACT
(MAKES ON PRESSURE INCREASE)



PRESSURE-SWITCH CONTACT
(BREAKS ON PRESSURE INCREASE)



PRESSURE TRANSMITTER

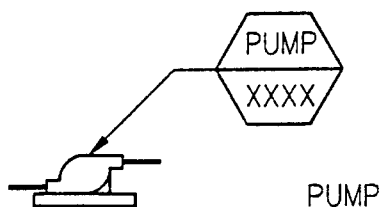

PUMP



FIELD-MOUNTED PRESSURE INDICATOR (GAUGE)

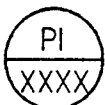

PRESSURE INDICATOR (GAUGE)



RELATIVE-HUMIDITY CONTROLLER



RELATIVE-HUMIDITY TRANSMITTER, DUCT-MOUNTED



RELATIVE-HUMIDITY TRANSMITTER, SPACE-MOUNTED

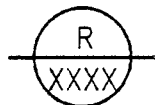

RELAY COIL

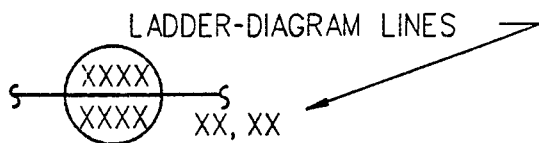

RELAY-COIL OR DEVICE OPERATING CIRCUIT

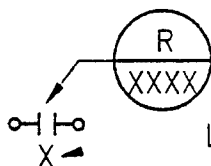

RELAY CONTACT

LADDER-DIAGRAM LINE

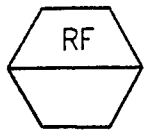

RETURN FAN

SIGNAL SELECTOR, HUMIDITY-CONTROL LOOP
LOW-SIGNAL SELECTOR

SMOKE DETECTOR, DUCT-MOUNTED



SPACE-TEMPERATURE TRANSMITTER AND RTD

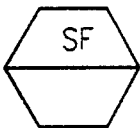

SUPPLY FAN



TEMPERATURE CONTROLLER

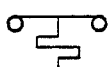
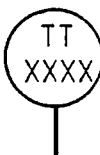

TEMPERATURE SENSING ELEMENT

TEMPERATURE-SWITCH, CONTACT
(MAKES ON TEMPERATURE RISE)
(BREAKS ON TEMPERATURE FALL)TEMPERATURE-SWITCH, CONTACT
(BREAKS ON TEMPERATURE RISE)
(MAKES ON TEMPERATURE FALL)TEMPERATURE TRANSMITTER, WITH CONTINUOUS
AVERAGING RTD DUCT MOUNTED

TEMPERATURE TRANSMITTER AND RTD

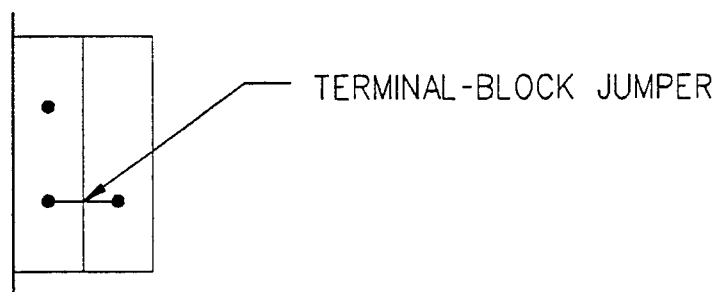
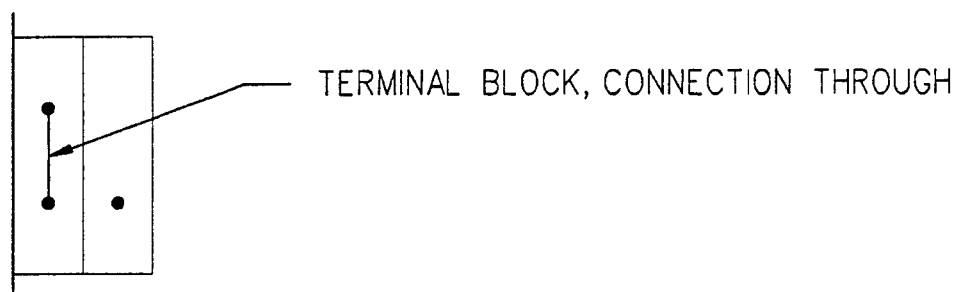
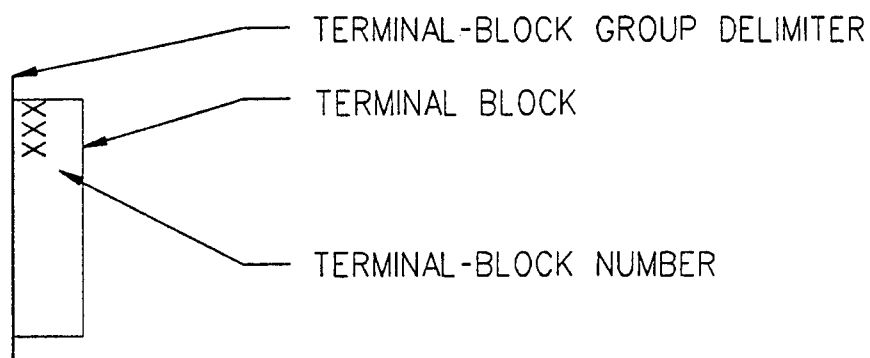

TERMINAL BLOCKS, AC POWER



TERMINAL BLOCKS, DC POWER



THERMOMETER, AVERAGING

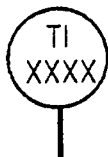

THERMOMETER, NON-AVERAGING

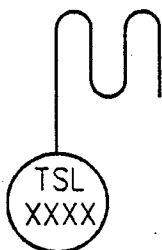

THERMOSTAT, LOW-TEMPERATURE PROTECTION



THERMOWELL



TIME CLOCK



TIME-DELAY RELAY



SIGNAL SELECTOR, TEMPERATURE-CONTROL LOOP, HIGH-SIGNAL SELECTOR

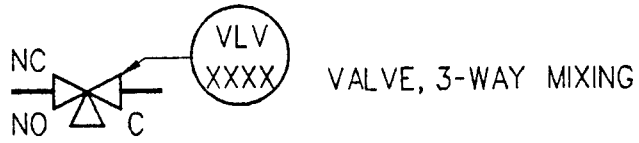

VALVE, 3-WAY MIXING



VALVE, NORMALLY CLOSED

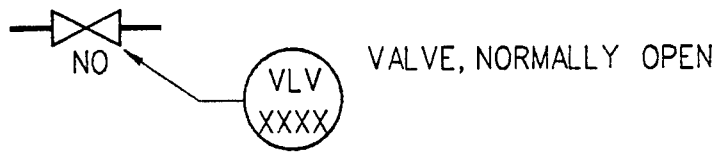

VALVE, NORMALLY OPEN

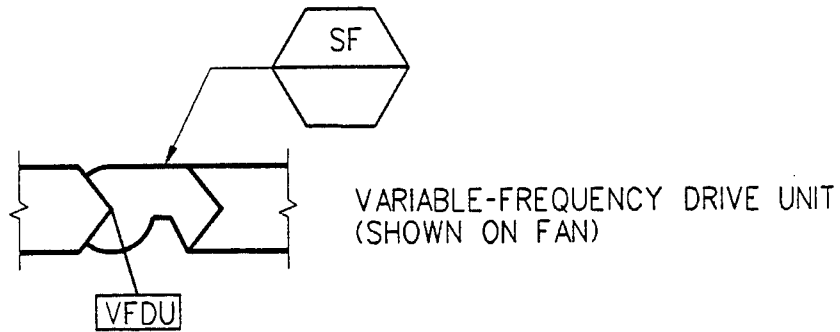

VARIABLE-FREQUENCY DRIVE UNIT (SHOWN ON FAN)

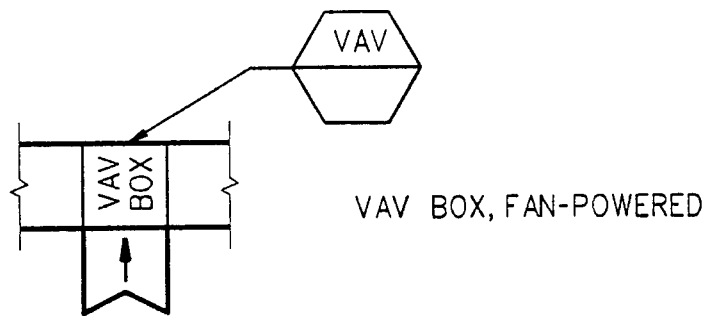

VAV BOX, FAN-POWERED

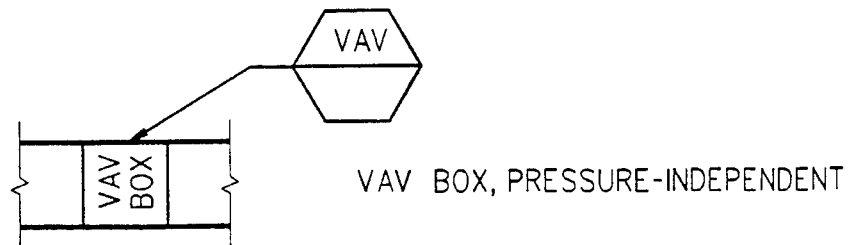

VAV BOX, PRESSURE-INDEPENDENT

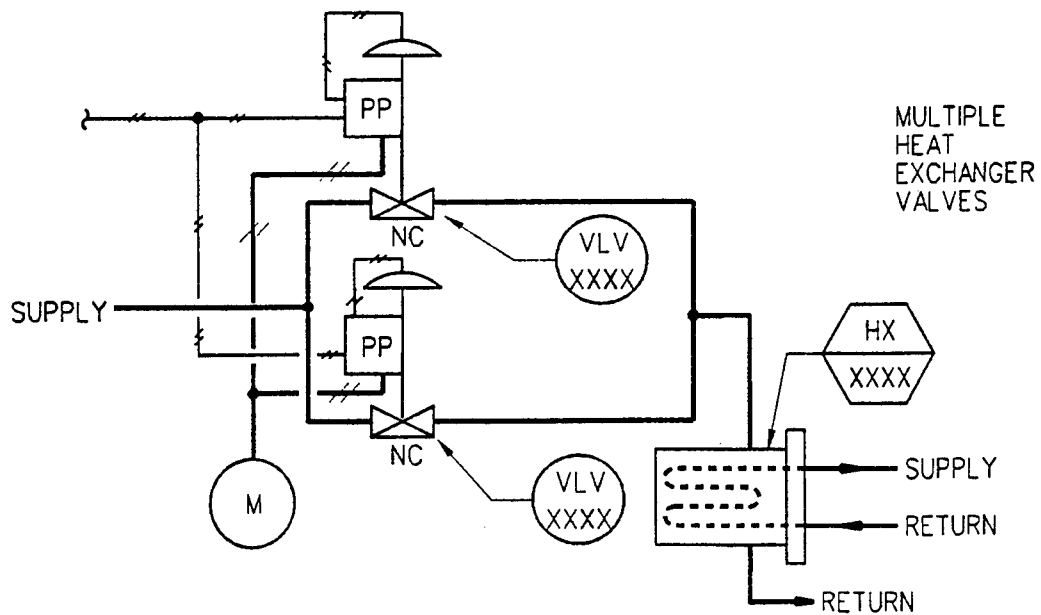
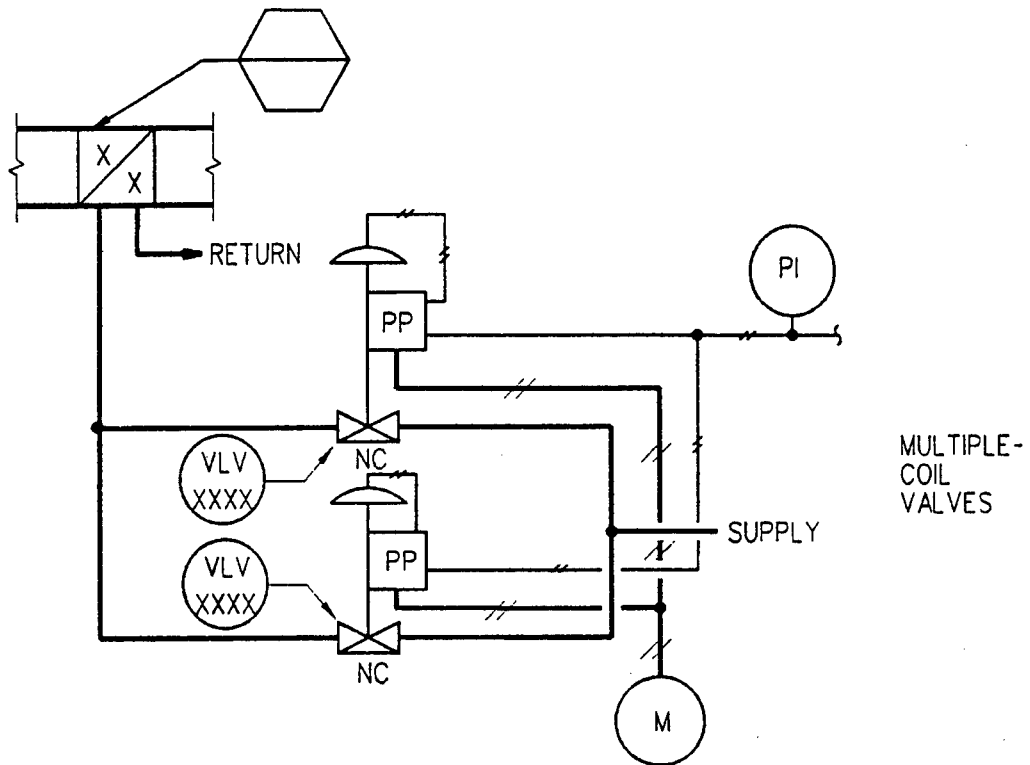

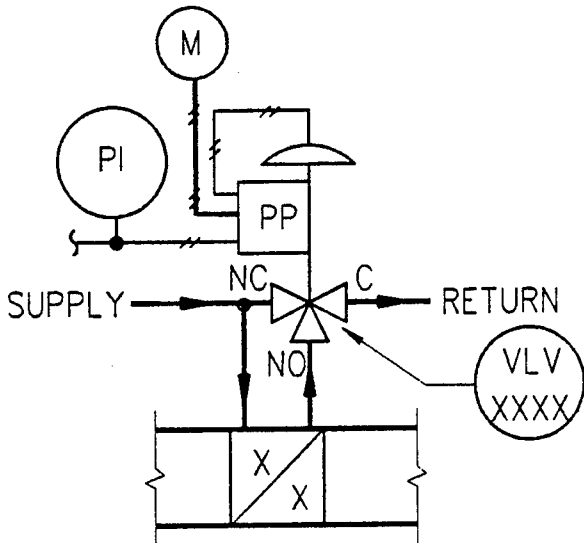

PNEUMATIC
3-WAY MIXING VALVE
PIPED NORMALLY OPEN IN
A BYPASS APPLICATION

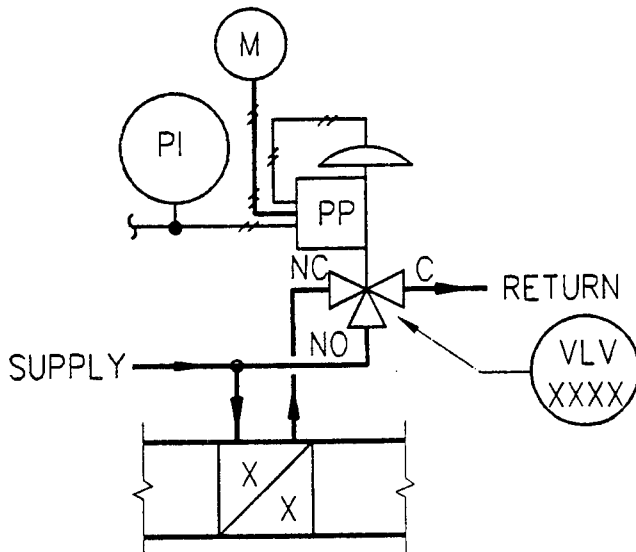

PNEUMATIC
3-WAY MIXING VALVE
PIPED NORMALLY CLOSED
IN A BYPASS APPLICATION

Appendix B: Controller V/mA Conversion to Temperature Tables

Volt or mA Conversion to Temperature
for
Honeywell, Powers and Yokogawa Controllers
(PV or CPA Input)

- 1) Read volts across controller input terminals
- 2) See table below to convert volts to milliamps (mA)
- 3) See table below to convert volts or mA to temperature

| V (volts) | I (mA) | Temperature | | | |
|--------------|-----------|-----------------------------|-----------------------------|-----------------------------|----------------------------|
| | | Sensor Span (-30 to 130) | Sensor Span (100 to 250) | Sensor Span (200 to 500) | Sensor Span (30 to 240) |
| 1.0 | 4.0 | -30 | 100.0 | 200.0 | 30.0 |
| 1.1 | 4.4 | -26 | 103.8 | 207.5 | 35.3 |
| 1.2 | 4.8 | -22 | 107.5 | 215.0 | 40.5 |
| 1.3 | 5.2 | -18 | 111.3 | 222.5 | 45.8 |
| 1.4 | 5.6 | -14 | 115.0 | 230.0 | 51.0 |
| 1.5 | 6.0 | -10 | 118.8 | 237.5 | 56.3 |
| 1.6 | 6.4 | -6 | 122.5 | 245.0 | 61.5 |
| 1.7 | 6.8 | -2 | 126.3 | 252.5 | 66.8 |
| 1.8 | 7.2 | 2 | 130.0 | 260.0 | 72.0 |
| 1.9 | 7.6 | 6 | 133.8 | 267.5 | 77.3 |
| 2 | 8.0 | 10 | 137.5 | 275.0 | 82.5 |
| 2.1 | 8.4 | 14 | 141.3 | 282.5 | 87.8 |
| 2.2 | 8.8 | 18 | 145.0 | 290.0 | 93.0 |
| 2.3 | 9.2 | 22 | 148.8 | 297.5 | 98.3 |
| 2.4 | 9.6 | 26 | 152.5 | 305.0 | 103.5 |
| 2.5 | 10.0 | 30 | 156.3 | 312.5 | 108.8 |
| 2.6 | 10.4 | 34 | 160.0 | 320.0 | 114.0 |
| 2.7 | 10.8 | 38 | 163.8 | 327.5 | 119.3 |
| 2.8 | 11.2 | 42 | 167.5 | 335.0 | 124.5 |
| 2.9 | 11.6 | 46 | 171.3 | 342.5 | 129.8 |
| 3 | 12.0 | 50 | 175.0 | 350.0 | 135.0 |
| 3.1 | 12.4 | 54 | 178.8 | 357.5 | 140.3 |
| 3.2 | 12.8 | 58 | 182.5 | 365.0 | 145.5 |
| 3.3 | 13.2 | 62 | 186.3 | 372.5 | 150.8 |
| 3.4 | 13.6 | 66 | 190.0 | 380.0 | 156.0 |
| 3.5 | 14.0 | 70 | 193.8 | 387.5 | 161.3 |
| 3.6 | 14.4 | 74 | 197.5 | 395.0 | 166.5 |
| 3.7 | 14.8 | 78 | 201.3 | 402.5 | 171.8 |
| 3.8 | 15.2 | 82 | 205.0 | 410.0 | 177.0 |
| 3.9 | 15.6 | 86 | 208.8 | 417.5 | 182.3 |
| 4 | 16.0 | 90 | 212.5 | 425.0 | 187.5 |
| 4.1 | 16.4 | 94 | 216.3 | 432.5 | 192.8 |
| 4.2 | 16.8 | 98 | 220.0 | 440.0 | 198.0 |
| 4.3 | 17.2 | 102 | 223.8 | 447.5 | 203.3 |
| 4.4 | 17.6 | 106 | 227.5 | 455.0 | 208.5 |
| 4.5 | 18.0 | 110 | 231.3 | 462.5 | 213.8 |
| 4.6 | 18.4 | 114 | 235.0 | 470.0 | 219.0 |
| 4.7 | 18.8 | 118 | 238.8 | 477.5 | 224.3 |
| 4.8 | 19.2 | 122 | 242.5 | 485.0 | 229.5 |
| 4.9 | 19.6 | 126 | 246.3 | 492.5 | 234.8 |
| 5 | 20.0 | 130 | 250.0 | 500.0 | 240.0 |

Equations:

V (Volts) = Measured at controller PV or CPA input

I (mA) = 250 ohms / measured volts

R = 250 ohms (resistor inside controller for PV input & CPA input)

Temperature = Low span + (mA-4mA)/16mA x range

range = High span - Low span

Volt or mA Conversion to Temperature for
Honeywell, Powers and Yokogawa Controllers
(PV or CPA Input)

- 1) Read volts across controllers input terminals
- 2) See table below to convert volts to milliamperes (mA)
- 3) See table below to convert volts or mA to temperature

| V (volts) | I (mA) | Temperature | | | |
|--------------|-----------|----------------------------|----------------------------|---------------------------|----------------------------|
| | | Sensor Span (30 to 100) | Sensor Span (30 to 130) | Sensor Span (50 to 85) | Sensor Span (40 to 140) |
| 1.0 | 4.0 | 30.0 | 30.0 | 50.0 | 40.0 |
| 1.1 | 4.4 | 31.8 | 32.5 | 50.9 | 42.5 |
| 1.2 | 4.8 | 33.5 | 35.0 | 51.8 | 45.0 |
| 1.3 | 5.2 | 35.3 | 37.5 | 52.6 | 47.5 |
| 1.4 | 5.6 | 37.0 | 40.0 | 53.5 | 50.0 |
| 1.5 | 6.0 | 38.8 | 42.5 | 54.4 | 52.5 |
| 1.6 | 6.4 | 40.5 | 45.0 | 55.3 | 55.0 |
| 1.7 | 6.8 | 42.3 | 47.5 | 56.1 | 57.5 |
| 1.8 | 7.2 | 44.0 | 50.0 | 57.0 | 60.0 |
| 1.9 | 7.6 | 45.8 | 52.5 | 57.9 | 62.5 |
| 2 | 8.0 | 47.5 | 55.0 | 58.8 | 65.0 |
| 2.1 | 8.4 | 49.3 | 57.5 | 59.6 | 67.5 |
| 2.2 | 8.8 | 51.0 | 60.0 | 60.5 | 70.0 |
| 2.3 | 9.2 | 52.8 | 62.5 | 61.4 | 72.5 |
| 2.4 | 9.6 | 54.5 | 65.0 | 62.3 | 75.0 |
| 2.5 | 10.0 | 56.3 | 67.5 | 63.1 | 77.5 |
| 2.6 | 10.4 | 58.0 | 70.0 | 64.0 | 80.0 |
| 2.7 | 10.8 | 59.8 | 72.5 | 64.9 | 82.5 |
| 2.8 | 11.2 | 61.5 | 75.0 | 65.8 | 85.0 |
| 2.9 | 11.6 | 63.3 | 77.5 | 66.6 | 87.5 |
| 3 | 12.0 | 65.0 | 80.0 | 67.5 | 90.0 |
| 3.1 | 12.4 | 66.8 | 82.5 | 68.4 | 92.5 |
| 3.2 | 12.8 | 68.5 | 85.0 | 69.3 | 95.0 |
| 3.3 | 13.2 | 70.3 | 87.5 | 70.1 | 97.5 |
| 3.4 | 13.6 | 72.0 | 90.0 | 71.0 | 100.0 |
| 3.5 | 14.0 | 73.8 | 92.5 | 71.9 | 102.5 |
| 3.6 | 14.4 | 75.5 | 95.0 | 72.8 | 105.0 |
| 3.7 | 14.8 | 77.3 | 97.5 | 73.6 | 107.5 |
| 3.8 | 15.2 | 79.0 | 100.0 | 74.5 | 110.0 |
| 3.9 | 15.6 | 80.8 | 102.5 | 75.4 | 112.5 |
| 4 | 16.0 | 82.5 | 105.0 | 76.3 | 115.0 |
| 4.1 | 16.4 | 84.3 | 107.5 | 77.1 | 117.5 |
| 4.2 | 16.8 | 86.0 | 110.0 | 78.0 | 120.0 |
| 4.3 | 17.2 | 87.8 | 112.5 | 78.9 | 122.5 |
| 4.4 | 17.6 | 89.5 | 115.0 | 79.8 | 125.0 |
| 4.5 | 18.0 | 91.3 | 117.5 | 80.6 | 127.5 |
| 4.6 | 18.4 | 93.0 | 120.0 | 81.5 | 130.0 |
| 4.7 | 18.8 | 94.8 | 122.5 | 82.4 | 132.5 |
| 4.8 | 19.2 | 96.5 | 125.0 | 83.3 | 135.0 |
| 4.9 | 19.6 | 98.3 | 127.5 | 84.1 | 137.5 |
| 5 | 20.0 | 100.0 | 130.0 | 85.0 | 140.0 |

Equations:

V (Volts) = Measured at controller PV or CPA input

I (mA) = 250 ohms / measured volts

R = 250 ohms (resistor inside controller for PV input & CPA input)

Temperature = Low span + (mA-4mA)/16mA x range

range = High span - Low span

Volt or mA Conversion to Temperature
for
TCS Controller

- 1) Read volts across controller input terminals
- 2) See table below to convert volts to milliamps (mA)
- 3) See table below to convert volts or mA to temperature

| | | Temperature | | | |
|--------------|-----------|-----------------------------|-----------------------------|-----------------------------|----------------------------|
| V (volts) | I (mA) | Sensor Span (-30 to 130) | Sensor Span (100 to 250) | Sensor Span (200 to 500) | Sensor Span (30 to 240) |
| 0.40 | 4.0 | -30 | 100.0 | 200.0 | 30.0 |
| 0.44 | 4.4 | -26 | 103.8 | 207.5 | 35.3 |
| 0.48 | 4.8 | -22 | 107.5 | 215.0 | 40.5 |
| 0.52 | 5.2 | -18 | 111.3 | 222.5 | 45.8 |
| 0.56 | 5.6 | -14 | 115.0 | 230.0 | 51.0 |
| 0.60 | 6.0 | -10 | 118.8 | 237.5 | 56.3 |
| 0.64 | 6.4 | -6 | 122.5 | 245.0 | 61.5 |
| 0.68 | 6.8 | -2 | 126.3 | 252.5 | 66.8 |
| 0.72 | 7.2 | 2 | 130.0 | 260.0 | 72.0 |
| 0.76 | 7.6 | 6 | 133.8 | 267.5 | 77.3 |
| 0.80 | 8.0 | 10 | 137.5 | 275.0 | 82.5 |
| 0.84 | 8.4 | 14 | 141.3 | 282.5 | 87.8 |
| 0.88 | 8.8 | 18 | 145.0 | 290.0 | 93.0 |
| 0.92 | 9.2 | 22 | 148.8 | 297.5 | 98.3 |
| 0.96 | 9.6 | 26 | 152.5 | 305.0 | 103.5 |
| 1.00 | 10.0 | 30 | 156.3 | 312.5 | 108.8 |
| 1.04 | 10.4 | 34 | 160.0 | 320.0 | 114.0 |
| 1.08 | 10.8 | 38 | 163.8 | 327.5 | 119.3 |
| 1.12 | 11.2 | 42 | 167.5 | 335.0 | 124.5 |
| 1.16 | 11.6 | 46 | 171.3 | 342.5 | 129.8 |
| 1.20 | 12.0 | 50 | 175.0 | 350.0 | 135.0 |
| 1.24 | 12.4 | 54 | 178.8 | 357.5 | 140.3 |
| 1.28 | 12.8 | 58 | 182.5 | 365.0 | 145.5 |
| 1.32 | 13.2 | 62 | 186.3 | 372.5 | 150.8 |
| 1.36 | 13.6 | 66 | 190.0 | 380.0 | 156.0 |
| 1.40 | 14.0 | 70 | 193.8 | 387.5 | 161.3 |
| 1.44 | 14.4 | 74 | 197.5 | 395.0 | 166.5 |
| 1.48 | 14.8 | 78 | 201.3 | 402.5 | 171.8 |
| 1.52 | 15.2 | 82 | 205.0 | 410.0 | 177.0 |
| 1.56 | 15.6 | 86 | 208.8 | 417.5 | 182.3 |
| 1.60 | 16.0 | 90 | 212.5 | 425.0 | 187.5 |
| 1.64 | 16.4 | 94 | 216.3 | 432.5 | 192.8 |
| 1.68 | 16.8 | 98 | 220.0 | 440.0 | 198.0 |
| 1.72 | 17.2 | 102 | 223.8 | 447.5 | 203.3 |
| 1.76 | 17.6 | 106 | 227.5 | 455.0 | 208.5 |
| 1.80 | 18.0 | 110 | 231.3 | 462.5 | 213.8 |
| 1.84 | 18.4 | 114 | 235.0 | 470.0 | 219.0 |
| 1.88 | 18.8 | 118 | 238.8 | 477.5 | 224.3 |
| 1.92 | 19.2 | 122 | 242.5 | 485.0 | 229.5 |
| 1.96 | 19.6 | 126 | 246.3 | 492.5 | 234.8 |
| 2.00 | 20.0 | 130 | 250.0 | 500.0 | 240.0 |

Equations:

V (Volts) = Measured at controller PV or CPA Input

I (mA) = 100 ohms / measured volts

R = 100 ohms (value of resistor inside controller across PV or CPA input)

Temperature = Low span + (mA - 4mA)/16 + range

range = High span - Low span

Volt or mA Conversion to Temperature
for
TCS Controller

- 1) Read volts across controller input terminals
- 2) See table below to convert volts to milliamperes (mA)
- 3) See table below to convert volts or mA to temperature

| V (volts) | I (mA) | Temperature | | | |
|--------------|-----------|----------------------------|----------------------------|---------------------------|----------------------------|
| | | Sensor Span (30 to 100) | Sensor Span (30 to 130) | Sensor Span (50 to 85) | Sensor Span (40 to 140) |
| 0.40 | 4.0 | 30.0 | 30.0 | 50.0 | 40.0 |
| 0.44 | 4.4 | 31.8 | 32.5 | 50.9 | 42.5 |
| 0.48 | 4.8 | 33.5 | 35.0 | 51.8 | 45.0 |
| 0.52 | 5.2 | 35.3 | 37.5 | 52.6 | 47.5 |
| 0.56 | 5.6 | 37.0 | 40.0 | 53.5 | 50.0 |
| 0.60 | 6.0 | 38.8 | 42.5 | 54.4 | 52.5 |
| 0.64 | 6.4 | 40.5 | 45.0 | 55.3 | 55.0 |
| 0.68 | 6.8 | 42.3 | 47.5 | 56.1 | 57.5 |
| 0.72 | 7.2 | 44.0 | 50.0 | 57.0 | 60.0 |
| 0.76 | 7.6 | 45.8 | 52.5 | 57.9 | 62.5 |
| 0.80 | 8.0 | 47.5 | 55.0 | 58.8 | 65.0 |
| 0.84 | 8.4 | 49.3 | 57.5 | 59.6 | 67.5 |
| 0.88 | 8.8 | 51.0 | 60.0 | 60.5 | 70.0 |
| 0.92 | 9.2 | 52.8 | 62.5 | 61.4 | 72.5 |
| 0.96 | 9.6 | 54.5 | 65.0 | 62.3 | 75.0 |
| 1.00 | 10.0 | 56.3 | 67.5 | 63.1 | 77.5 |
| 1.04 | 10.4 | 58.0 | 70.0 | 64.0 | 80.0 |
| 1.08 | 10.8 | 59.8 | 72.5 | 64.9 | 82.5 |
| 1.12 | 11.2 | 61.5 | 75.0 | 65.8 | 85.0 |
| 1.16 | 11.6 | 63.3 | 77.5 | 66.6 | 87.5 |
| 1.20 | 12.0 | 65.0 | 80.0 | 67.5 | 90.0 |
| 1.24 | 12.4 | 66.8 | 82.5 | 68.4 | 92.5 |
| 1.28 | 12.8 | 68.5 | 85.0 | 69.3 | 95.0 |
| 1.32 | 13.2 | 70.3 | 87.5 | 70.1 | 97.5 |
| 1.36 | 13.6 | 72.0 | 90.0 | 71.0 | 100.0 |
| 1.40 | 14.0 | 73.8 | 92.5 | 71.9 | 102.5 |
| 1.44 | 14.4 | 75.5 | 95.0 | 72.8 | 105.0 |
| 1.48 | 14.8 | 77.3 | 97.5 | 73.6 | 107.5 |
| 1.52 | 15.2 | 79.0 | 100.0 | 74.5 | 110.0 |
| 1.56 | 15.6 | 80.8 | 102.5 | 75.4 | 112.5 |
| 1.60 | 16.0 | 82.5 | 105.0 | 76.3 | 115.0 |
| 1.64 | 16.4 | 84.3 | 107.5 | 77.1 | 117.5 |
| 1.68 | 16.8 | 86.0 | 110.0 | 78.0 | 120.0 |
| 1.72 | 17.2 | 87.8 | 112.5 | 78.9 | 122.5 |
| 1.76 | 17.6 | 89.5 | 115.0 | 79.8 | 125.0 |
| 1.80 | 18.0 | 91.3 | 117.5 | 80.6 | 127.5 |
| 1.84 | 18.4 | 93.0 | 120.0 | 81.5 | 130.0 |
| 1.88 | 18.8 | 94.8 | 122.5 | 82.4 | 132.5 |
| 1.92 | 19.2 | 96.5 | 125.0 | 83.3 | 135.0 |
| 1.96 | 19.6 | 98.3 | 127.5 | 84.1 | 137.5 |
| 2.00 | 20.0 | 100.0 | 130.0 | 85.0 | 140.0 |

Equations:

V (Volts) = Measured at controller PV or CPA input

I (mA) = 100 ohms / measured volts

R = 100 ohms (value of resistor inside controller across PV or CPA input)

Temperature = Low span + (mA - 4mA)/16 + range

range = High span - Low span

Volt or mA Conversion to Temperature
for
Taylor Controller
(Process variable (PV) Input)

- 1) Read volts across controller input terminals
- 2) See table below to convert volts to milliamperes (mA)
- 3) See table below to convert volts or mA to temperature

| V (volts) | I (mA) | Temperature | | | |
|--------------|-----------|-----------------------------|-----------------------------|-----------------------------|----------------------------|
| | | Sensor Span (-30 to 130) | Sensor Span (100 to 250) | Sensor Span (200 to 500) | Sensor Span (30 to 240) |
| 0.40 | 4.0 | -30 | 100.0 | 200.0 | 30.0 |
| 0.44 | 4.4 | -26 | 103.8 | 207.5 | 35.3 |
| 0.48 | 4.8 | -22 | 107.5 | 215.0 | 40.5 |
| 0.52 | 5.2 | -18 | 111.3 | 222.5 | 45.8 |
| 0.56 | 5.6 | -14 | 115.0 | 230.0 | 51.0 |
| 0.60 | 6.0 | -10 | 118.8 | 237.5 | 56.3 |
| 0.64 | 6.4 | -6 | 122.5 | 245.0 | 61.5 |
| 0.68 | 6.8 | -2 | 126.3 | 252.5 | 66.8 |
| 0.72 | 7.2 | 2 | 130.0 | 260.0 | 72.0 |
| 0.76 | 7.6 | 6 | 133.8 | 267.5 | 77.3 |
| 0.80 | 8.0 | 10 | 137.5 | 275.0 | 82.5 |
| 0.84 | 8.4 | 14 | 141.3 | 282.5 | 87.8 |
| 0.88 | 8.8 | 18 | 145.0 | 290.0 | 93.0 |
| 0.92 | 9.2 | 22 | 148.8 | 297.5 | 98.3 |
| 0.96 | 9.6 | 26 | 152.5 | 305.0 | 103.5 |
| 1.00 | 10.0 | 30 | 156.3 | 312.5 | 108.8 |
| 1.04 | 10.4 | 34 | 160.0 | 320.0 | 114.0 |
| 1.08 | 10.8 | 38 | 163.8 | 327.5 | 119.3 |
| 1.12 | 11.2 | 42 | 167.5 | 335.0 | 124.5 |
| 1.16 | 11.6 | 46 | 171.3 | 342.5 | 129.8 |
| 1.20 | 12.0 | 50 | 175.0 | 350.0 | 135.0 |
| 1.24 | 12.4 | 54 | 178.8 | 357.5 | 140.3 |
| 1.28 | 12.8 | 58 | 182.5 | 365.0 | 145.5 |
| 1.32 | 13.2 | 62 | 186.3 | 372.5 | 150.8 |
| 1.36 | 13.6 | 66 | 190.0 | 380.0 | 156.0 |
| 1.40 | 14.0 | 70 | 193.8 | 387.5 | 161.3 |
| 1.44 | 14.4 | 74 | 197.5 | 395.0 | 166.5 |
| 1.48 | 14.8 | 78 | 201.3 | 402.5 | 171.8 |
| 1.52 | 15.2 | 82 | 205.0 | 410.0 | 177.0 |
| 1.56 | 15.6 | 86 | 208.8 | 417.5 | 182.3 |
| 1.60 | 16.0 | 90 | 212.5 | 425.0 | 187.5 |
| 1.64 | 16.4 | 94 | 216.3 | 432.5 | 192.8 |
| 1.68 | 16.8 | 98 | 220.0 | 440.0 | 198.0 |
| 1.72 | 17.2 | 102 | 223.8 | 447.5 | 203.3 |
| 1.76 | 17.6 | 106 | 227.5 | 455.0 | 208.5 |
| 1.80 | 18.0 | 110 | 231.3 | 462.5 | 213.8 |
| 1.84 | 18.4 | 114 | 235.0 | 470.0 | 219.0 |
| 1.88 | 18.8 | 118 | 238.8 | 477.5 | 224.3 |
| 1.92 | 19.2 | 122 | 242.5 | 485.0 | 229.5 |
| 1.96 | 19.6 | 126 | 246.3 | 492.5 | 234.8 |
| 2.00 | 20.0 | 130 | 250.0 | 500.0 | 240.0 |

Equations:

V (Volts) = Measured at controller PV input

I (mA) = 100 ohms / measured volts

R = 100 ohms (value of resistor inside controller across PV input)

Temperature = Low span + (mA - 4mA)/16mA x range

range = High span - Low span

Appendix C: Transmitter mA Output Versus Process Variable Input Tables

TRANSMITTER mA OUTPUT VERSUS PROCESS VARIABLE INPUT
 OUTPUT OF 40 TO 140 F TEMPERATURE TRANSMITTER

| TEMP (F) | OUTPUT (mA) | TEMP (F) | OUTPUT (mA) | TEMP (F) | OUTPUT (mA) |
|-------------|----------------|-------------|----------------|-------------|----------------|
| 40 | 4.00 | 80 | 10.40 | 120 | 16.80 |
| 41 | 4.16 | 81 | 10.56 | 121 | 16.96 |
| 42 | 4.32 | 82 | 10.72 | 122 | 17.12 |
| 43 | 4.48 | 83 | 10.88 | 123 | 17.28 |
| 44 | 4.64 | 84 | 11.04 | 124 | 17.44 |
| 45 | 4.80 | 85 | 11.20 | 125 | 17.60 |
| 46 | 4.96 | 86 | 11.36 | 126 | 17.76 |
| 47 | 5.12 | 87 | 11.52 | 127 | 17.92 |
| 48 | 5.28 | 88 | 11.68 | 128 | 18.08 |
| 49 | 5.44 | 89 | 11.84 | 129 | 18.24 |
| 50 | 5.60 | 90 | 12.00 | 130 | 18.40 |
| 51 | 5.76 | 91 | 12.16 | 131 | 18.56 |
| 52 | 5.92 | 92 | 12.32 | 132 | 18.72 |
| 53 | 6.08 | 93 | 12.48 | 133 | 18.88 |
| 54 | 6.24 | 94 | 12.64 | 134 | 19.04 |
| 55 | 6.40 | 95 | 12.80 | 135 | 19.20 |
| 56 | 6.56 | 96 | 12.96 | 136 | 19.36 |
| 57 | 6.72 | 97 | 13.12 | 137 | 19.52 |
| 58 | 6.88 | 98 | 13.28 | 138 | 19.68 |
| 59 | 7.04 | 99 | 13.44 | 139 | 19.84 |
| 60 | 7.20 | 100 | 13.60 | 140 | 20.00 |
| 61 | 7.36 | 101 | 13.76 | | |
| 62 | 7.52 | 102 | 13.92 | | |
| 63 | 7.68 | 103 | 14.08 | | |
| 64 | 7.84 | 104 | 14.24 | | |
| 65 | 8.00 | 105 | 14.40 | | |
| 66 | 8.16 | 106 | 14.56 | | |
| 67 | 8.32 | 107 | 14.72 | | |
| 68 | 8.48 | 108 | 14.88 | | |
| 69 | 8.64 | 109 | 15.04 | | |
| 70 | 8.80 | 110 | 15.20 | | |
| 71 | 8.96 | 111 | 15.36 | | |
| 72 | 9.12 | 112 | 15.52 | | |
| 73 | 9.28 | 113 | 15.68 | | |
| 74 | 9.44 | 114 | 15.84 | | |
| 75 | 9.60 | 115 | 16.00 | | |
| 76 | 9.76 | 116 | 16.16 | | |
| 77 | 9.92 | 117 | 16.32 | | |
| 78 | 10.08 | 118 | 16.48 | | |
| 79 | 10.24 | 119 | 16.64 | | |

TRANSMITTER mA OUTPUT VERSUS PROCESS VARIABLE INPUT

OUTPUT OF -30 TO 130 F TEMPERATURE TRANSMITTER

| TEMP (F) | OUTPUT (mA) | TEMP (F) | OUTPUT (mA) | TEMP (F) | OUTPUT (mA) |
|-------------|----------------|-------------|----------------|-------------|----------------|
| -30 | 4.0 | 10 | 8.0 | 50 | 12.0 |
| -29 | 4.1 | 11 | 8.1 | 51 | 12.1 |
| -28 | 4.2 | 12 | 8.2 | 52 | 12.2 |
| -27 | 4.3 | 13 | 8.3 | 53 | 12.3 |
| -26 | 4.4 | 14 | 8.4 | 54 | 12.4 |
| -25 | 4.5 | 15 | 8.5 | 55 | 12.5 |
| -24 | 4.6 | 16 | 8.6 | 56 | 12.6 |
| -23 | 4.7 | 17 | 8.7 | 57 | 12.7 |
| -22 | 4.8 | 18 | 8.8 | 58 | 12.8 |
| -21 | 4.9 | 19 | 8.9 | 59 | 12.9 |
| -20 | 5.0 | 20 | 9.0 | 60 | 13.0 |
| -19 | 5.1 | 21 | 9.1 | 61 | 13.1 |
| -18 | 5.2 | 22 | 9.2 | 62 | 13.2 |
| -17 | 5.3 | 23 | 9.3 | 63 | 13.3 |
| -16 | 5.4 | 24 | 9.4 | 64 | 13.4 |
| -15 | 5.5 | 25 | 9.5 | 65 | 13.5 |
| -14 | 5.6 | 26 | 9.6 | 66 | 13.6 |
| -13 | 5.7 | 27 | 9.7 | 67 | 13.7 |
| -12 | 5.8 | 28 | 9.8 | 68 | 13.8 |
| -11 | 5.9 | 29 | 9.9 | 69 | 13.9 |
| -10 | 6.0 | 30 | 10.0 | 70 | 14.0 |
| -9 | 6.1 | 31 | 10.1 | 71 | 14.1 |
| -8 | 6.2 | 32 | 10.2 | 72 | 14.2 |
| -7 | 6.3 | 33 | 10.3 | 73 | 14.3 |
| -6 | 6.4 | 34 | 10.4 | 74 | 14.4 |
| -5 | 6.5 | 35 | 10.5 | 75 | 14.5 |
| -4 | 6.6 | 36 | 10.6 | 76 | 14.6 |
| -3 | 6.7 | 37 | 10.7 | 77 | 14.7 |
| -2 | 6.8 | 38 | 10.8 | 78 | 14.8 |
| -1 | 6.9 | 39 | 10.9 | 79 | 14.9 |
| 0 | 7.0 | 40 | 11.0 | 80 | 15.0 |
| 1 | 7.1 | 41 | 11.1 | 81 | 15.1 |
| 2 | 7.2 | 42 | 11.2 | 82 | 15.2 |
| 3 | 7.3 | 43 | 11.3 | 83 | 15.3 |
| 4 | 7.4 | 44 | 11.4 | 84 | 15.4 |
| 5 | 7.5 | 45 | 11.5 | 85 | 15.5 |
| 6 | 7.6 | 46 | 11.6 | 86 | 15.6 |
| 7 | 7.7 | 47 | 11.7 | 87 | 15.7 |
| 8 | 7.8 | 48 | 11.8 | 88 | 15.8 |
| 9 | 7.9 | 49 | 11.9 | 89 | 15.9 |

TRANSMITTER mA OUTPUT VERSUS PROCESS VARIABLE INPUT

OUTPUT OF -30 TO 130 F TEMPERATURE TRANSMITTER

| TEMP (F) | OUTPUT (mA) | TEMP (F) | OUTPUT (mA) | TEMP (F) | OUTPUT (mA) |
|-------------|----------------|-------------|----------------|-------------|----------------|
| 90 | 16.0 | | | | |
| 91 | 16.1 | | | | |
| 92 | 16.2 | | | | |
| 93 | 16.3 | | | | |
| 94 | 16.4 | | | | |
| 95 | 16.5 | | | | |
| 96 | 16.6 | | | | |
| 97 | 16.7 | | | | |
| 98 | 16.8 | | | | |
| 99 | 16.9 | | | | |
| 100 | 17.0 | | | | |
| 101 | 17.1 | | | | |
| 102 | 17.2 | | | | |
| 103 | 17.3 | | | | |
| 104 | 17.4 | | | | |
| 105 | 17.5 | | | | |
| 106 | 17.6 | | | | |
| 107 | 17.7 | | | | |
| 108 | 17.8 | | | | |
| 109 | 17.9 | | | | |
| 110 | 18.0 | | | | |
| 111 | 18.1 | | | | |
| 112 | 18.2 | | | | |
| 113 | 18.3 | | | | |
| 114 | 18.4 | | | | |
| 115 | 18.5 | | | | |
| 116 | 18.6 | | | | |
| 117 | 18.7 | | | | |
| 118 | 18.8 | | | | |
| 119 | 18.9 | | | | |
| 120 | 19.0 | | | | |
| 121 | 19.1 | | | | |
| 122 | 19.2 | | | | |
| 123 | 19.3 | | | | |
| 124 | 19.4 | | | | |
| 125 | 19.5 | | | | |
| 126 | 19.6 | | | | |
| 127 | 19.7 | | | | |
| 128 | 19.8 | | | | |
| 129 | 19.9 | | | | |
| 130 | 20.0 | | | | |

TRANSMITTER mA OUTPUT VERSUS PROCESS VARIABLE INPUT

OUTPUT OF 50 TO 85 F TEMPERATURE TRANSMITTER

| TEMP (F) | OUTPUT (mA) | TEMP (F) | OUTPUT (mA) | TEMP (F) | OUTPUT (mA) |
|-------------|----------------|-------------|----------------|-------------|----------------|
| 50 | 4.00 | | | | |
| 51 | 4.56 | | | | |
| 52 | 4.91 | | | | |
| 53 | 5.37 | | | | |
| 54 | 5.83 | | | | |
| 55 | 6.29 | | | | |
| 56 | 6.74 | | | | |
| 57 | 7.20 | | | | |
| 58 | 7.66 | | | | |
| 59 | 8.11 | | | | |
| 60 | 8.57 | | | | |
| 61 | 9.03 | | | | |
| 62 | 9.49 | | | | |
| 63 | 9.94 | | | | |
| 64 | 10.40 | | | | |
| 65 | 10.86 | | | | |
| 66 | 11.31 | | | | |
| 67 | 11.77 | | | | |
| 68 | 12.23 | | | | |
| 69 | 12.69 | | | | |
| 70 | 13.14 | | | | |
| 71 | 13.60 | | | | |
| 72 | 14.06 | | | | |
| 73 | 14.51 | | | | |
| 74 | 14.97 | | | | |
| 75 | 15.43 | | | | |
| 76 | 15.89 | | | | |
| 77 | 16.34 | | | | |
| 78 | 16.80 | | | | |
| 79 | 17.26 | | | | |
| 80 | 17.71 | | | | |
| 81 | 18.17 | | | | |
| 82 | 18.63 | | | | |
| 83 | 19.09 | | | | |
| 84 | 19.54 | | | | |
| 85 | 20.00 | | | | |

TRANSMITTER mA OUTPUT VERSUS PROCESS VARIABLE INPUT

OUTPUT OF 30 TO 130 F TEMPERATURE TRANSMITTER

| TEMP (F) | OUTPUT (mA) | TEMP (F) | OUTPUT (mA) | TEMP (F) | OUTPUT (mA) |
|-------------|----------------|-------------|----------------|-------------|----------------|
| 30 | 4.00 | 70 | 10.40 | 110 | 16.80 |
| 31 | 4.16 | 71 | 10.56 | 111 | 16.96 |
| 32 | 4.32 | 72 | 10.72 | 112 | 17.12 |
| 33 | 4.48 | 73 | 10.88 | 113 | 17.28 |
| 34 | 4.64 | 74 | 11.04 | 114 | 17.44 |
| 35 | 4.80 | 75 | 11.20 | 115 | 17.60 |
| 36 | 4.96 | 76 | 11.36 | 116 | 17.76 |
| 37 | 5.12 | 77 | 11.52 | 117 | 17.92 |
| 38 | 5.28 | 78 | 11.68 | 118 | 18.08 |
| 39 | 5.44 | 79 | 11.84 | 119 | 18.24 |
| 40 | 5.60 | 80 | 12.00 | 120 | 18.40 |
| 41 | 5.76 | 81 | 12.16 | 121 | 18.56 |
| 42 | 5.92 | 82 | 12.32 | 122 | 18.72 |
| 43 | 6.08 | 83 | 12.48 | 123 | 18.88 |
| 44 | 6.24 | 84 | 12.64 | 124 | 19.04 |
| 45 | 6.40 | 85 | 12.80 | 125 | 19.20 |
| 46 | 6.56 | 86 | 12.96 | 126 | 19.36 |
| 47 | 6.72 | 87 | 13.12 | 127 | 19.52 |
| 48 | 6.88 | 88 | 13.28 | 128 | 19.68 |
| 49 | 7.04 | 89 | 13.44 | 129 | 19.84 |
| 50 | 7.20 | 90 | 13.60 | 130 | 20.00 |
| 51 | 7.36 | 91 | 13.76 | | |
| 52 | 7.52 | 92 | 13.92 | | |
| 53 | 7.68 | 93 | 14.08 | | |
| 54 | 7.84 | 94 | 14.24 | | |
| 55 | 8.00 | 95 | 14.40 | | |
| 56 | 8.16 | 96 | 14.56 | | |
| 57 | 8.32 | 97 | 14.72 | | |
| 58 | 8.48 | 98 | 14.88 | | |
| 59 | 8.64 | 99 | 15.04 | | |
| 60 | 8.80 | 100 | 15.20 | | |
| 61 | 8.96 | 101 | 15.36 | | |
| 62 | 9.12 | 102 | 15.52 | | |
| 63 | 9.28 | 103 | 15.68 | | |
| 64 | 9.44 | 104 | 15.84 | | |
| 65 | 9.60 | 105 | 16.00 | | |
| 66 | 9.76 | 106 | 16.16 | | |
| 67 | 9.92 | 107 | 16.32 | | |
| 68 | 10.08 | 108 | 16.48 | | |
| 69 | 10.24 | 109 | 16.64 | | |

TRANSMITTER mA OUTPUT VERSUS PROCESS VARIABLE INPUT

OUTPUT OF 200 TO 500 F TEMPERATURE TRANSMITTER

| TEMP (F) | OUTPUT (mA) | TEMP (F) | OUTPUT (mA) | TEMP (F) | OUTPUT (mA) |
|-------------|----------------|-------------|----------------|-------------|----------------|
| 200 | 4.00 | 350 | 12.00 | | |
| 205 | 4.27 | 355 | 12.27 | | |
| 210 | 4.53 | 360 | 12.53 | | |
| 215 | 4.80 | 365 | 12.80 | | |
| 220 | 5.07 | 370 | 13.07 | | |
| 225 | 5.33 | 375 | 13.33 | | |
| 230 | 5.60 | 380 | 13.60 | | |
| 235 | 5.87 | 385 | 13.87 | | |
| 240 | 6.13 | 390 | 14.13 | | |
| 245 | 6.40 | 395 | 14.40 | | |
| 250 | 6.67 | 400 | 14.67 | | |
| 255 | 6.93 | 405 | 14.93 | | |
| 260 | 7.20 | 410 | 15.20 | | |
| 265 | 7.47 | 415 | 15.47 | | |
| 270 | 7.73 | 420 | 15.73 | | |
| 275 | 8.00 | 425 | 16.00 | | |
| 280 | 8.27 | 430 | 16.26 | | |
| 285 | 8.53 | 435 | 16.53 | | |
| 290 | 8.80 | 440 | 16.80 | | |
| 295 | 9.07 | 445 | 17.07 | | |
| 300 | 9.33 | 450 | 17.33 | | |
| 305 | 9.60 | 455 | 17.60 | | |
| 310 | 9.87 | 460 | 17.87 | | |
| 315 | 10.13 | 465 | 18.13 | | |
| 320 | 10.40 | 470 | 18.40 | | |
| 325 | 10.67 | 475 | 18.67 | | |
| 330 | 10.93 | 480 | 18.93 | | |
| 335 | 11.20 | 485 | 19.20 | | |
| 340 | 11.47 | 490 | 19.47 | | |
| 345 | 11.73 | 495 | 19.73 | | |
| | | 500 | 20.00 | | |

TRANSMITTER mA OUTPUT VERSUS PROCESS VARIABLE INPUT

OUTPUT OF 30 TO 240 F TEMPERATURE TRANSMITTER

| TEMP (F) | OUTPUT (mA) | TEMP (F) | OUTPUT (mA) | TEMP (F) | OUTPUT (mA) |
|-------------|----------------|-------------|----------------|-------------|----------------|
| 30 | 4.00 | 102 | 9.49 | 174 | 14.97 |
| 32 | 4.15 | 104 | 9.64 | 176 | 15.12 |
| 34 | 4.30 | 106 | 9.79 | 178 | 15.28 |
| 36 | 4.46 | 108 | 9.94 | 180 | 15.43 |
| 38 | 4.61 | 110 | 10.10 | 182 | 15.58 |
| 40 | 4.76 | 112 | 10.25 | 184 | 15.73 |
| 42 | 4.91 | 114 | 10.40 | 186 | 15.89 |
| 44 | 5.07 | 116 | 10.55 | 188 | 16.04 |
| 46 | 5.22 | 118 | 10.70 | 190 | 16.19 |
| 48 | 5.37 | 120 | 10.86 | 192 | 16.34 |
| 50 | 5.52 | 122 | 11.01 | 194 | 16.50 |
| 52 | 5.68 | 124 | 11.16 | 196 | 16.65 |
| 54 | 5.83 | 126 | 11.31 | 198 | 16.80 |
| 56 | 5.98 | 128 | 11.47 | 200 | 16.95 |
| 58 | 6.13 | 130 | 11.62 | 202 | 17.10 |
| 60 | 6.29 | 132 | 11.77 | 204 | 17.26 |
| 62 | 6.44 | 134 | 11.92 | 206 | 17.41 |
| 64 | 6.59 | 136 | 12.08 | 208 | 17.56 |
| 66 | 6.74 | 138 | 12.23 | 210 | 17.71 |
| 68 | 6.90 | 140 | 12.38 | 212 | 17.87 |
| 70 | 7.05 | 142 | 12.53 | 214 | 18.02 |
| 72 | 7.20 | 144 | 12.69 | 216 | 18.17 |
| 74 | 7.35 | 146 | 12.84 | 218 | 18.32 |
| 76 | 7.50 | 148 | 12.99 | 220 | 18.48 |
| 78 | 7.66 | 150 | 13.14 | 222 | 18.63 |
| 80 | 7.81 | 152 | 13.30 | 224 | 18.78 |
| 82 | 7.96 | 154 | 13.45 | 226 | 18.93 |
| 84 | 8.11 | 156 | 13.60 | 228 | 19.09 |
| 86 | 8.27 | 158 | 13.75 | 230 | 19.24 |
| 88 | 8.42 | 160 | 13.90 | 232 | 19.39 |
| 90 | 8.57 | 162 | 14.06 | 234 | 19.54 |
| 92 | 8.72 | 164 | 14.21 | 236 | 19.70 |
| 94 | 8.88 | 166 | 14.36 | 238 | 19.85 |
| 96 | 9.03 | 168 | 14.51 | 240 | 20.00 |
| 98 | 9.18 | 170 | 14.67 | | |
| 100 | 9.33 | 172 | 14.82 | | |

TRANSMITTER mA OUTPUT VERSUS PROCESS VARIABLE INPUT

OUTPUT OF 100 TO 250 F TEMPERATURE TRANSMITTER

| TEMP (F) | OUTPUT (mA) | TEMP (F) | OUTPUT (mA) | TEMP (F) | OUTPUT (mA) |
|-------------|----------------|-------------|----------------|-------------|----------------|
| 100 | 4.00 | 140 | 8.27 | 180 | 12.53 |
| 101 | 4.11 | 141 | 8.37 | 181 | 12.64 |
| 102 | 4.21 | 142 | 8.48 | 182 | 12.75 |
| 103 | 4.32 | 143 | 8.59 | 183 | 12.85 |
| 104 | 4.43 | 144 | 8.69 | 184 | 12.96 |
| 105 | 4.53 | 145 | 8.80 | 185 | 13.07 |
| 106 | 4.64 | 146 | 8.91 | 186 | 13.17 |
| 107 | 4.75 | 147 | 9.01 | 187 | 13.28 |
| 108 | 4.85 | 148 | 9.12 | 188 | 13.39 |
| 109 | 4.96 | 149 | 9.23 | 189 | 13.49 |
| 110 | 5.07 | 150 | 9.33 | 190 | 13.60 |
| 111 | 5.17 | 151 | 9.44 | 191 | 13.71 |
| 112 | 5.28 | 152 | 9.55 | 192 | 13.81 |
| 113 | 5.39 | 153 | 9.65 | 193 | 13.92 |
| 114 | 5.49 | 154 | 9.76 | 194 | 14.03 |
| 115 | 5.60 | 155 | 9.87 | 195 | 14.13 |
| 116 | 5.71 | 156 | 9.97 | 196 | 14.24 |
| 117 | 5.81 | 157 | 10.08 | 197 | 14.35 |
| 118 | 5.92 | 158 | 10.19 | 198 | 14.45 |
| 119 | 6.03 | 159 | 10.29 | 199 | 14.56 |
| 120 | 6.13 | 160 | 10.40 | 200 | 14.67 |
| 121 | 6.24 | 161 | 10.51 | 201 | 14.77 |
| 122 | 6.35 | 162 | 10.61 | 202 | 14.88 |
| 123 | 6.45 | 163 | 10.72 | 203 | 14.99 |
| 124 | 6.56 | 164 | 10.83 | 204 | 15.09 |
| 125 | 6.67 | 165 | 10.93 | 205 | 15.20 |
| 126 | 6.77 | 166 | 11.04 | 206 | 15.31 |
| 127 | 6.88 | 167 | 11.15 | 207 | 15.41 |
| 128 | 6.99 | 168 | 11.25 | 208 | 15.52 |
| 129 | 7.09 | 169 | 11.36 | 209 | 15.63 |
| 130 | 7.20 | 170 | 11.47 | 210 | 15.73 |
| 131 | 7.31 | 171 | 11.57 | 211 | 15.84 |
| 132 | 7.41 | 172 | 11.68 | 212 | 15.95 |
| 133 | 7.52 | 173 | 11.79 | 213 | 16.05 |
| 134 | 7.63 | 174 | 11.89 | 214 | 16.16 |
| 135 | 7.73 | 175 | 12.00 | 215 | 16.27 |
| 136 | 7.84 | 176 | 12.11 | 216 | 16.37 |
| 137 | 7.95 | 177 | 12.21 | 217 | 16.48 |
| 138 | 8.05 | 178 | 12.32 | 218 | 16.59 |
| 139 | 8.16 | 179 | 12.43 | 219 | 16.69 |

TRANSMITTER mA OUTPUT VERSUS PROCESS VARIABLE INPUT

OUTPUT OF 100 TO 250 F TEMPERATURE TRANSMITTER

| TEMP (F) | OUTPUT (mA) | TEMP (F) | OUTPUT (mA) | TEMP (F) | OUTPUT (mA) |
|-------------|----------------|-------------|----------------|-------------|----------------|
| 220 | 16.80 | | | | |
| 221 | 16.91 | | | | |
| 222 | 17.01 | | | | |
| 223 | 17.12 | | | | |
| 224 | 17.23 | | | | |
| 225 | 17.33 | | | | |
| 226 | 17.44 | | | | |
| 227 | 17.55 | | | | |
| 228 | 17.65 | | | | |
| 229 | 17.76 | | | | |
| 230 | 17.87 | | | | |
| 231 | 17.97 | | | | |
| 232 | 18.08 | | | | |
| 233 | 18.19 | | | | |
| 234 | 18.29 | | | | |
| 235 | 18.40 | | | | |
| 236 | 18.51 | | | | |
| 237 | 18.61 | | | | |
| 238 | 18.72 | | | | |
| 239 | 18.83 | | | | |
| 240 | 18.93 | | | | |
| 241 | 19.04 | | | | |
| 242 | 19.15 | | | | |
| 243 | 19.25 | | | | |
| 244 | 19.36 | | | | |
| 245 | 19.47 | | | | |
| 246 | 19.57 | | | | |
| 247 | 19.68 | | | | |
| 248 | 19.79 | | | | |
| 249 | 19.89 | | | | |
| 250 | 20.00 | | | | |

TRANSMITTER mA OUTPUT VERSUS PROCESS VARIABLE INPUT

OUTPUT OF 0 TO 100% RELATIVE HUMIDITY TRANSMITTER

| HUMIDITY (%) | OUTPUT (mA) | HUMIDITY (%) | OUTPUT (mA) |
|--------------|-------------|--------------|-------------|
| 0 | 4.00 | 40 | 10.40 |
| 1 | 4.16 | 41 | 10.56 |
| 2 | 4.32 | 42 | 10.72 |
| 3 | 4.48 | 43 | 10.88 |
| 4 | 4.64 | 44 | 11.04 |
| 5 | 4.80 | 45 | 11.20 |
| 6 | 4.96 | 46 | 11.36 |
| 7 | 5.12 | 47 | 11.52 |
| 8 | 5.28 | 48 | 11.68 |
| 9 | 5.44 | 49 | 11.84 |
| 10 | 5.60 | 50 | 12.00 |
| 11 | 5.76 | 51 | 12.16 |
| 12 | 5.92 | 52 | 12.32 |
| 13 | 6.08 | 53 | 12.48 |
| 14 | 6.24 | 54 | 12.64 |
| 15 | 6.40 | 55 | 12.80 |
| 16 | 6.56 | 56 | 12.96 |
| 17 | 6.72 | 57 | 13.12 |
| 18 | 6.88 | 58 | 13.28 |
| 19 | 7.04 | 59 | 13.44 |
| 20 | 7.20 | 60 | 13.60 |
| 21 | 7.36 | 61 | 13.76 |
| 22 | 7.52 | 62 | 13.92 |
| 23 | 7.68 | 63 | 14.08 |
| 24 | 7.84 | 64 | 14.24 |
| 25 | 8.00 | 65 | 14.40 |
| 26 | 8.16 | 66 | 14.56 |
| 27 | 8.32 | 67 | 14.72 |
| 28 | 8.48 | 68 | 14.88 |
| 29 | 8.64 | 69 | 15.04 |
| 30 | 8.80 | 70 | 15.20 |
| 31 | 8.96 | 71 | 15.36 |
| 32 | 9.12 | 72 | 15.52 |
| 33 | 9.28 | 73 | 15.68 |
| 34 | 9.44 | 74 | 15.84 |
| 35 | 9.60 | 75 | 16.00 |
| 36 | 9.76 | 76 | 16.16 |
| 37 | 9.92 | 77 | 16.32 |
| 38 | 10.08 | 78 | 16.48 |
| 39 | 10.24 | 79 | 16.64 |
| | | 80 | 16.80 |

TRANSMITTER mA OUTPUT VERSUS PROCESS VARIABLE INPUT

OUTPUT OF 0 TO 100% RELATIVE HUMIDITY TRANSMITTER

| HUMIDITY (%) | OUTPUT (mA) | HUMIDITY (%) | OUTPUT (mA) |
|--------------|-------------|--------------|-------------|
| 81 | 16.96 | 91 | 18.56 |
| 82 | 17.12 | 92 | 18.72 |
| 83 | 17.28 | 93 | 18.88 |
| 84 | 17.44 | 94 | 19.04 |
| 85 | 17.60 | 95 | 19.20 |
| 86 | 17.76 | 96 | 19.36 |
| 87 | 17.92 | 97 | 19.52 |
| 88 | 18.08 | 98 | 19.68 |
| 89 | 18.24 | 99 | 19.84 |
| 90 | 18.40 | 100 | 20.00 |

TRANSMITTER mA OUTPUT VERSUS PROCESS VARIABLE INPUT

OUTPUT OF 20 TO 80% RELATIVE HUMIDITY TRANSMITTER

| HUMIDITY (%) | OUTPUT (mA) | HUMIDITY (%) | OUTPUT (mA) |
|--------------|-------------|--------------|-------------|
| 20 | 4.00 | 50 | 12.00 |
| 21 | 4.27 | 51 | 12.27 |
| 22 | 4.53 | 52 | 12.53 |
| 23 | 4.80 | 53 | 12.80 |
| 24 | 5.07 | 54 | 13.07 |
| 25 | 5.33 | 55 | 13.33 |
| 26 | 5.60 | 56 | 13.60 |
| 27 | 5.87 | 57 | 13.87 |
| 28 | 6.13 | 58 | 14.13 |
| 29 | 6.40 | 59 | 14.40 |
| 30 | 6.67 | 60 | 14.67 |
| 31 | 6.93 | 61 | 14.93 |
| 32 | 7.20 | 62 | 15.20 |
| 33 | 7.47 | 63 | 15.47 |
| 34 | 7.73 | 64 | 15.73 |
| 35 | 8.00 | 65 | 16.00 |
| 36 | 8.27 | 66 | 16.27 |
| 37 | 8.53 | 67 | 16.53 |
| 38 | 8.80 | 68 | 16.80 |
| 39 | 9.07 | 69 | 17.07 |
| 40 | 9.33 | 70 | 17.33 |
| 41 | 9.60 | 71 | 17.60 |
| 42 | 9.87 | 72 | 17.87 |
| 43 | 10.13 | 73 | 18.13 |
| 44 | 10.40 | 74 | 18.40 |
| 45 | 10.67 | 75 | 18.67 |
| 46 | 10.93 | 76 | 18.93 |
| 47 | 11.20 | 77 | 19.20 |
| 48 | 11.47 | 78 | 19.47 |
| 49 | 11.73 | 79 | 19.73 |
| | | 80 | 20.00 |

TRANSMITTER mA OUTPUT VERSUS PROCESS VARIABLE INPUT

OUTPUT OF 0 TO 2.0 IWC STATIC PRESSURE TRANSMITTER

| PRESSURE (iwc) | OUTPUT (mA) |
|----------------|-------------|
| 0 | 4.00 |
| 0.1 | 4.80 |
| 0.2 | 5.60 |
| 0.3 | 6.40 |
| 0.4 | 7.20 |
| 0.5 | 8.00 |
| 0.6 | 8.80 |
| 0.7 | 9.60 |
| 0.8 | 10.40 |
| 0.9 | 11.20 |
| 1 | 12.00 |
| 1.1 | 12.80 |
| 1.2 | 13.60 |
| 1.3 | 14.40 |
| 1.4 | 15.20 |
| 1.5 | 16.00 |
| 1.6 | 16.80 |
| 1.7 | 17.60 |
| 1.8 | 18.40 |
| 1.9 | 19.20 |
| 2 | 20.00 |

TRANSMITTER mA OUTPUT VERSUS PROCESS VARIABLE INPUT

OUTPUT OF 125 TO 2500 FPM AIR FLOW TRANSMITTER

| AIR FLOW (fpm) | OUTPUT (mA) | AIR FLOW (fpm) | OUTPUT (mA) |
|----------------|-------------|----------------|-------------|
| 125 | 4.00 | 1325 | 12.08 |
| 150 | 4.17 | 1350 | 12.25 |
| 175 | 4.34 | 1375 | 12.42 |
| 200 | 4.51 | 1400 | 12.59 |
| 225 | 4.67 | 1425 | 12.76 |
| 250 | 4.84 | 1450 | 12.93 |
| 275 | 5.01 | 1475 | 13.09 |
| 300 | 5.18 | 1500 | 13.26 |
| 325 | 5.35 | 1525 | 13.43 |
| 350 | 5.52 | 1550 | 13.60 |
| 375 | 5.68 | 1575 | 13.77 |
| 400 | 5.85 | 1600 | 13.94 |
| 425 | 6.02 | 1625 | 14.11 |
| 450 | 6.19 | 1650 | 14.27 |
| 475 | 6.36 | 1675 | 14.44 |
| 500 | 6.53 | 1700 | 14.61 |
| 525 | 6.69 | 1725 | 14.78 |
| 550 | 6.86 | 1750 | 14.95 |
| 575 | 7.03 | 1775 | 15.12 |
| 600 | 7.20 | 1800 | 15.28 |
| 625 | 7.37 | 1825 | 15.45 |
| 650 | 7.54 | 1850 | 15.62 |
| 675 | 7.71 | 1875 | 15.79 |
| 700 | 7.87 | 1900 | 15.96 |
| 725 | 8.04 | 1925 | 16.13 |
| 750 | 8.21 | 1950 | 16.29 |
| 775 | 8.38 | 1975 | 16.46 |
| 800 | 8.55 | 2000 | 16.63 |
| 825 | 8.72 | 2025 | 16.80 |
| 850 | 8.88 | 2050 | 16.97 |
| 875 | 9.05 | 2075 | 17.14 |
| 900 | 9.22 | 2100 | 17.31 |
| 925 | 9.39 | 2125 | 17.47 |
| 950 | 9.56 | 2150 | 17.64 |
| 975 | 9.73 | 2175 | 17.81 |
| 1000 | 9.89 | 2200 | 17.98 |
| 1025 | 10.06 | 2225 | 18.15 |
| 1050 | 10.23 | 2250 | 18.32 |
| 1075 | 10.40 | 2275 | 18.48 |
| 1100 | 10.57 | 2300 | 18.65 |
| 1125 | 10.74 | 2325 | 18.82 |
| 1150 | 10.91 | 2350 | 18.99 |
| 1175 | 11.07 | 2375 | 19.16 |
| 1200 | 11.24 | 2400 | 19.33 |
| 1225 | 11.41 | 2425 | 19.49 |
| 1250 | 11.58 | 2450 | 19.66 |
| 1275 | 11.75 | 2475 | 19.83 |
| 1300 | 11.92 | 2500 | 20.00 |

TRANSMITTER mA OUTPUT VERSUS PROCESS VARIABLE INPUT

OUTPUT OF 0 TO 0.1 IWC PITOT-TUBE AIR FLOW TRANSMITTER
FOR AIR FLOW VELOCITIES OF 500 TO 1200 FPM

| AIR FLOW (fpm) | OUTPUT (mA) |
|----------------|-------------|
| 500 | 4.00 |
| 525 | 4.57 |
| 550 | 5.14 |
| 575 | 5.71 |
| 600 | 6.29 |
| 625 | 6.86 |
| 650 | 7.43 |
| 675 | 8.00 |
| 700 | 8.57 |
| 725 | 9.14 |
| 750 | 9.71 |
| 775 | 10.29 |
| 800 | 10.86 |
| 825 | 11.43 |
| 850 | 12.00 |
| 875 | 12.57 |
| 900 | 13.14 |
| 925 | 13.71 |
| 950 | 14.29 |
| 975 | 14.86 |
| 1000 | 15.43 |
| 1025 | 16.00 |
| 1050 | 16.57 |
| 1075 | 17.14 |
| 1100 | 17.71 |
| 1125 | 18.29 |
| 1150 | 18.86 |
| 1175 | 19.43 |
| 1200 | 20.00 |

TRANSMITTER mA OUTPUT VERSUS PROCESS VARIABLE INPUT

OUTPUT OF 0 TO 0.25 IWC PITOT-TUBE AIR FLOW TRANSMITTER
FOR AIR FLOW VELOCITIES OF 500 TO 1800 FPM

| AIR FLOW (fpm) | OUTPUT (mA) | AIR FLOW (fpm) | OUTPUT (mA) |
|----------------|-------------|----------------|-------------|
| 500 | 4.00 | 1175 | 12.31 |
| 525 | 4.31 | 1200 | 12.62 |
| 550 | 4.62 | 1225 | 12.92 |
| 575 | 4.92 | 1250 | 13.23 |
| 600 | 5.23 | 1275 | 13.54 |
| 625 | 5.54 | 1300 | 13.85 |
| 650 | 5.85 | 1325 | 14.15 |
| 675 | 6.15 | 1350 | 14.46 |
| 700 | 6.46 | 1375 | 14.77 |
| 725 | 6.77 | 1400 | 15.08 |
| 750 | 7.08 | 1425 | 15.38 |
| 775 | 7.38 | 1450 | 15.69 |
| 800 | 7.69 | 1475 | 16.00 |
| 825 | 8.00 | 1500 | 16.31 |
| 850 | 8.31 | 1525 | 16.62 |
| 875 | 8.62 | 1550 | 16.92 |
| 900 | 8.92 | 1575 | 17.23 |
| 925 | 9.23 | 1600 | 17.54 |
| 950 | 9.54 | 1625 | 17.85 |
| 975 | 9.85 | 1650 | 18.15 |
| 1000 | 10.15 | 1675 | 18.46 |
| 1025 | 10.46 | 1700 | 18.77 |
| 1050 | 10.77 | 1725 | 19.08 |
| 1075 | 11.08 | 1750 | 19.38 |
| 1100 | 11.38 | 1775 | 19.69 |
| 1125 | 11.69 | 1800 | 20.00 |
| 1150 | 12.00 | | |

TRANSMITTER mA OUTPUT VERSUS PROCESS VARIABLE INPUT

OUTPUT OF 0 TO 0.5 IWC PITOT-TUBE AIR FLOW TRANSMITTER
FOR AIR FLOW VELOCITIES OF 500 TO 2500 FPM

| AIR FLOW (fpm) | OUTPUT (mA) | AIR FLOW (fpm) | OUTPUT (mA) |
|----------------|-------------|----------------|-------------|
| 500 | 4.00 | 1500 | 12.00 |
| 525 | 4.20 | 1525 | 12.20 |
| 550 | 4.40 | 1550 | 12.40 |
| 575 | 4.60 | 1575 | 12.60 |
| 600 | 4.80 | 1600 | 12.80 |
| 625 | 5.00 | 1625 | 13.00 |
| 650 | 5.20 | 1650 | 13.20 |
| 675 | 5.40 | 1675 | 13.40 |
| 700 | 5.60 | 1700 | 13.60 |
| 725 | 5.80 | 1725 | 13.80 |
| 750 | 6.00 | 1750 | 14.00 |
| 775 | 6.20 | 1775 | 14.20 |
| 800 | 6.40 | 1800 | 14.40 |
| 825 | 6.60 | 1825 | 14.60 |
| 850 | 6.80 | 1850 | 14.80 |
| 875 | 7.00 | 1875 | 15.00 |
| 900 | 7.20 | 1900 | 15.20 |
| 925 | 7.40 | 1925 | 15.40 |
| 950 | 7.60 | 1950 | 15.60 |
| 975 | 7.80 | 1975 | 15.80 |
| 1000 | 8.00 | 2000 | 16.00 |
| 1025 | 8.20 | 2025 | 16.20 |
| 1050 | 8.40 | 2050 | 16.40 |
| 1075 | 8.60 | 2075 | 16.60 |
| 1100 | 8.80 | 2100 | 16.80 |
| 1125 | 9.00 | 2125 | 17.00 |
| 1150 | 9.20 | 2150 | 17.20 |
| 1175 | 9.40 | 2175 | 17.40 |
| 1200 | 9.60 | 2200 | 17.60 |
| 1225 | 9.80 | 2225 | 17.80 |
| 1250 | 10.00 | 2250 | 18.00 |
| 1275 | 10.20 | 2275 | 18.20 |
| 1300 | 10.40 | 2300 | 18.40 |
| 1325 | 10.60 | 2325 | 18.60 |
| 1350 | 10.80 | 2350 | 18.80 |
| 1375 | 11.00 | 2375 | 19.00 |
| 1400 | 11.20 | 2400 | 19.20 |
| 1425 | 11.40 | 2425 | 19.40 |
| 1450 | 11.60 | 2450 | 19.60 |
| 1475 | 11.80 | 2475 | 19.80 |
| | | 2500 | 20.00 |

Appendix D: Standard Resistance Values for 100 ohm Platinum RTD Tables

STANDARD RESISTANCE VALUES FOR 100-OHM PLATINUM RTD

| TEMP (F) | RESISTANCE (OHMS) | TEMP (F) | RESISTANCE (OHMS) | TEMP (F) | RESISTANCE (OHMS) |
|-------------|----------------------|-------------|----------------------|-------------|----------------------|
| -30 | 86.72 | 10 | 95.13 | 50 | 103.90 |
| -29 | 87.27 | 11 | 95.36 | 51 | 104.12 |
| -28 | 87.81 | 12 | 95.59 | 52 | 104.33 |
| -27 | 88.34 | 13 | 95.81 | 53 | 104.55 |
| -26 | 88.85 | 14 | 96.04 | 54 | 104.77 |
| -25 | 89.36 | 15 | 96.26 | 55 | 104.98 |
| -24 | 89.85 | 16 | 96.49 | 56 | 105.20 |
| -23 | 90.34 | 17 | 96.71 | 57 | 105.42 |
| -22 | 90.82 | 18 | 96.94 | 58 | 105.63 |
| -21 | 91.29 | 19 | 97.16 | 59 | 105.85 |
| -20 | 91.75 | 20 | 97.38 | 60 | 106.06 |
| -19 | 92.21 | 21 | 97.60 | 61 | 106.28 |
| -18 | 92.65 | 22 | 97.82 | 62 | 106.50 |
| -17 | 93.09 | 23 | 98.04 | 63 | 106.71 |
| -16 | 93.53 | 24 | 98.26 | 64 | 106.93 |
| -15 | 93.96 | 25 | 98.48 | 65 | 107.14 |
| -14 | 94.38 | 26 | 98.70 | 66 | 107.36 |
| -13 | 94.80 | 27 | 98.91 | 67 | 107.58 |
| -12 | 95.22 | 28 | 99.13 | 68 | 107.79 |
| -11 | 95.63 | 29 | 99.35 | 69 | 108.01 |
| -10 | 96.04 | 30 | 99.57 | 70 | 108.22 |
| -9 | 96.44 | 31 | 99.78 | 71 | 108.44 |
| -8 | 96.85 | 32 | 100.00 | 72 | 108.66 |
| -7 | 97.25 | 33 | 100.22 | 73 | 108.87 |
| -6 | 97.64 | 34 | 100.43 | 74 | 109.09 |
| -5 | 98.04 | 35 | 100.65 | 75 | 109.30 |
| -4 | 98.43 | 36 | 100.87 | 76 | 109.52 |
| -3 | 98.83 | 37 | 101.09 | 77 | 109.73 |
| -2 | 99.22 | 38 | 101.30 | 78 | 109.95 |
| -1 | 99.61 | 39 | 101.52 | 79 | 110.16 |
| 0 | 100.00 | 40 | 101.74 | 80 | 110.38 |
| 1 | 100.39 | 41 | 101.95 | 81 | 110.59 |
| 2 | 100.78 | 42 | 102.17 | 82 | 110.81 |
| 3 | 101.17 | 43 | 102.39 | 83 | 111.03 |
| 4 | 101.56 | 44 | 102.60 | 84 | 111.24 |
| 5 | 101.96 | 45 | 102.82 | 85 | 111.46 |
| 6 | 102.35 | 46 | 103.04 | 86 | 111.67 |
| 7 | 102.75 | 47 | 103.25 | 87 | 111.89 |
| 8 | 103.14 | 48 | 103.47 | 88 | 112.10 |
| 9 | 103.54 | 49 | 103.69 | 89 | 112.32 |

STANDARD RESISTANCE VALUES FOR 100-OHM PLATINUM RTD

| TEMP (F) | RESISTANCE (OHMS) | TEMP (F) | RESISTANCE (OHMS) | TEMP (F) | RESISTANCE (OHMS) |
|-------------|----------------------|-------------|----------------------|-------------|----------------------|
| 90 | 112.53 | 130 | 121.10 | 170 | 129.62 |
| 91 | 112.75 | 131 | 121.32 | 171 | 129.83 |
| 92 | 112.96 | 132 | 121.53 | 172 | 130.04 |
| 93 | 113.18 | 133 | 121.74 | 173 | 130.25 |
| 94 | 113.39 | 134 | 121.96 | 174 | 130.46 |
| 95 | 113.61 | 135 | 122.17 | 175 | 130.68 |
| 96 | 113.82 | 136 | 122.38 | 176 | 130.89 |
| 97 | 114.04 | 137 | 122.60 | 177 | 131.10 |
| 98 | 114.25 | 138 | 122.81 | 178 | 131.31 |
| 99 | 114.46 | 139 | 123.02 | 179 | 131.52 |
| 100 | 114.68 | 140 | 123.24 | 180 | 131.73 |
| 101 | 114.89 | 141 | 123.45 | 181 | 131.95 |
| 102 | 115.11 | 142 | 123.66 | 182 | 132.16 |
| 103 | 115.32 | 143 | 123.88 | 183 | 132.37 |
| 104 | 115.54 | 144 | 124.09 | 184 | 132.58 |
| 105 | 115.75 | 145 | 124.30 | 185 | 132.79 |
| 106 | 115.97 | 146 | 124.51 | 186 | 133.00 |
| 107 | 116.18 | 147 | 124.73 | 187 | 133.22 |
| 108 | 116.40 | 148 | 124.94 | 188 | 133.43 |
| 109 | 116.61 | 149 | 125.15 | 189 | 133.64 |
| 110 | 116.82 | 150 | 125.37 | 190 | 133.85 |
| 111 | 117.04 | 151 | 125.58 | 191 | 134.06 |
| 112 | 117.25 | 152 | 125.79 | 192 | 134.27 |
| 113 | 117.47 | 153 | 126.00 | 193 | 134.48 |
| 114 | 117.68 | 154 | 126.22 | 194 | 134.70 |
| 115 | 117.90 | 155 | 126.43 | 195 | 134.91 |
| 116 | 118.11 | 156 | 126.64 | 196 | 135.12 |
| 117 | 118.32 | 157 | 126.85 | 197 | 135.33 |
| 118 | 118.54 | 158 | 127.07 | 198 | 135.54 |
| 119 | 118.75 | 159 | 127.28 | 199 | 135.75 |
| 120 | 118.97 | 160 | 127.49 | 200 | 135.96 |
| 121 | 119.18 | 161 | 127.70 | 201 | 136.17 |
| 122 | 119.39 | 162 | 127.92 | 202 | 136.38 |
| 123 | 119.61 | 163 | 128.13 | 203 | 136.59 |
| 124 | 119.82 | 164 | 128.34 | 204 | 136.81 |
| 125 | 120.03 | 165 | 128.55 | 205 | 137.02 |
| 126 | 120.25 | 166 | 128.77 | 206 | 137.23 |
| 127 | 120.46 | 167 | 128.98 | 207 | 137.44 |
| 128 | 120.68 | 168 | 129.19 | 208 | 137.65 |
| 129 | 120.89 | 169 | 129.40 | 209 | 137.86 |

STANDARD RESISTANCE VALUES FOR 100-OHM PLATINUM RTD

| TEMP (F) | RESISTANCE (OHMS) | TEMP (F) | RESISTANCE (OHMS) | TEMP (F) | RESISTANCE (OHMS) |
|-------------|----------------------|-------------|----------------------|-------------|----------------------|
| 210 | 138.07 | 250 | 146.47 | 290 | 154.80 |
| 211 | 138.28 | 251 | 146.68 | 291 | 155.01 |
| 212 | 138.49 | 252 | 146.88 | 292 | 155.22 |
| 213 | 138.70 | 253 | 147.09 | 293 | 155.43 |
| 214 | 138.91 | 254 | 147.30 | 294 | 155.64 |
| 215 | 139.12 | 255 | 147.51 | 295 | 155.84 |
| 216 | 139.33 | 256 | 147.72 | 296 | 156.05 |
| 217 | 139.54 | 257 | 147.93 | 297 | 156.26 |
| 218 | 139.75 | 258 | 148.14 | 298 | 156.47 |
| 219 | 139.96 | 259 | 148.35 | 299 | 156.67 |
| 220 | 140.17 | 260 | 148.56 | 300 | 156.88 |
| 221 | 140.38 | 261 | 148.77 | 301 | 157.09 |
| 222 | 140.60 | 262 | 148.97 | 302 | 157.30 |
| 223 | 140.81 | 263 | 149.18 | 303 | 157.50 |
| 224 | 141.02 | 264 | 149.39 | 304 | 157.71 |
| 225 | 141.23 | 265 | 149.60 | 305 | 157.92 |
| 226 | 141.44 | 266 | 149.81 | 306 | 158.12 |
| 227 | 141.65 | 267 | 150.02 | 307 | 158.33 |
| 228 | 141.86 | 268 | 150.23 | 308 | 158.54 |
| 229 | 142.07 | 269 | 150.43 | 309 | 158.75 |
| 230 | 142.28 | 270 | 150.64 | 310 | 158.95 |
| 231 | 142.49 | 271 | 150.85 | 311 | 159.16 |
| 232 | 142.70 | 272 | 151.06 | 312 | 159.37 |
| 233 | 142.91 | 273 | 151.27 | 313 | 159.57 |
| 234 | 143.11 | 274 | 151.48 | 314 | 159.78 |
| 235 | 143.32 | 275 | 151.68 | 315 | 159.99 |
| 236 | 143.53 | 276 | 151.89 | 316 | 160.19 |
| 237 | 143.74 | 277 | 152.10 | 317 | 160.40 |
| 238 | 143.95 | 278 | 152.31 | 318 | 160.61 |
| 239 | 144.16 | 279 | 152.52 | 319 | 160.81 |
| 240 | 144.37 | 280 | 152.73 | 320 | 161.02 |
| 241 | 144.58 | 281 | 152.93 | 321 | 161.23 |
| 242 | 144.79 | 282 | 153.14 | 322 | 161.43 |
| 243 | 145.00 | 283 | 153.35 | 323 | 161.64 |
| 244 | 145.21 | 284 | 153.56 | 324 | 161.85 |
| 245 | 145.42 | 285 | 153.77 | 325 | 162.05 |
| 246 | 145.63 | 286 | 153.97 | 326 | 162.26 |
| 247 | 145.84 | 287 | 154.18 | 327 | 162.47 |
| 248 | 146.05 | 288 | 154.39 | 328 | 162.67 |
| 249 | 146.26 | 289 | 154.60 | 329 | 162.88 |

STANDARD RESISTANCE VALUES FOR 100-OHM PLATINUM RTD

| TEMP (F) | RESISTANCE (OHMS) | TEMP (F) | RESISTANCE (OHMS) | TEMP (F) | RESISTANCE (OHMS) |
|-------------|----------------------|-------------|----------------------|-------------|----------------------|
| 330 | 163.09 | 370 | 171.31 | 410 | 179.47 |
| 331 | 163.29 | 371 | 171.51 | 411 | 179.67 |
| 332 | 163.50 | 372 | 171.72 | 412 | 179.88 |
| 333 | 163.70 | 373 | 171.92 | 413 | 180.08 |
| 334 | 163.91 | 374 | 172.13 | 414 | 180.28 |
| 335 | 164.12 | 375 | 172.33 | 415 | 180.49 |
| 336 | 164.32 | 376 | 172.54 | 416 | 180.69 |
| 337 | 164.53 | 377 | 172.74 | 417 | 180.89 |
| 338 | 164.73 | 378 | 172.94 | 418 | 181.11 |
| 339 | 164.94 | 379 | 173.15 | 419 | 181.31 |
| 340 | 165.15 | 380 | 173.35 | 420 | 181.51 |
| 341 | 165.35 | 381 | 173.56 | 421 | 181.71 |
| 342 | 165.56 | 382 | 173.76 | 422 | 181.91 |
| 343 | 165.76 | 383 | 173.97 | 423 | 182.11 |
| 344 | 165.97 | 384 | 174.17 | 424 | 182.31 |
| 345 | 166.18 | 385 | 174.38 | 425 | 182.52 |
| 346 | 166.38 | 386 | 174.58 | 426 | 182.72 |
| 347 | 166.59 | 387 | 174.78 | 427 | 182.92 |
| 348 | 166.79 | 388 | 174.99 | 428 | 183.13 |
| 349 | 167.00 | 389 | 175.19 | 429 | 183.33 |
| 350 | 167.20 | 390 | 175.40 | 430 | 183.53 |
| 351 | 167.41 | 391 | 175.60 | 431 | 183.73 |
| 352 | 167.61 | 392 | 175.80 | 432 | 183.94 |
| 353 | 167.82 | 393 | 176.01 | 433 | 184.14 |
| 354 | 168.03 | 394 | 176.21 | 434 | 184.34 |
| 355 | 168.23 | 395 | 176.42 | 435 | 184.54 |
| 356 | 168.44 | 396 | 176.62 | 436 | 184.75 |
| 357 | 168.64 | 397 | 176.82 | 437 | 184.95 |
| 358 | 168.85 | 398 | 177.03 | 438 | 185.15 |
| 359 | 169.05 | 399 | 177.23 | 439 | 185.35 |
| 360 | 169.26 | 400 | 177.44 | 440 | 185.56 |
| 361 | 169.46 | 401 | 177.64 | 441 | 185.76 |
| 362 | 169.67 | 402 | 177.84 | 442 | 185.96 |
| 363 | 169.87 | 403 | 178.05 | 443 | 186.16 |
| 364 | 170.08 | 404 | 178.25 | 444 | 186.36 |
| 365 | 170.28 | 405 | 178.45 | 445 | 186.57 |
| 366 | 170.49 | 406 | 178.66 | 446 | 186.77 |
| 367 | 170.69 | 407 | 178.86 | 447 | 186.97 |
| 368 | 170.90 | 408 | 179.06 | 448 | 187.17 |
| 369 | 171.10 | 409 | 179.27 | 449 | 187.37 |

STANDARD RESISTANCE VALUES FOR 100-OHM PLATINUM RTD

| TEMP (F) | RESISTANCE (OHMS) | TEMP (F) | RESISTANCE (OHMS) | TEMP (F) | RESISTANCE (OHMS) |
|-------------|----------------------|-------------|----------------------|-------------|----------------------|
| 450 | 187.58 | 490 | 195.62 | | |
| 451 | 187.78 | 491 | 195.82 | | |
| 452 | 187.98 | 492 | 196.02 | | |
| 453 | 188.18 | 493 | 196.23 | | |
| 454 | 188.38 | 494 | 196.43 | | |
| 455 | 188.59 | 495 | 196.63 | | |
| 456 | 188.79 | 496 | 196.83 | | |
| 457 | 188.99 | 497 | 197.03 | | |
| 458 | 189.19 | 498 | 197.23 | | |
| 459 | 189.39 | 499 | 197.43 | | |
| 460 | 189.59 | 500 | 197.63 | | |
| 461 | 189.80 | | | | |
| 462 | 190.00 | | | | |
| 463 | 190.20 | | | | |
| 464 | 190.40 | | | | |
| 465 | 190.60 | | | | |
| 466 | 190.80 | | | | |
| 467 | 191.00 | | | | |
| 468 | 191.21 | | | | |
| 469 | 191.41 | | | | |
| 470 | 191.61 | | | | |
| 471 | 191.81 | | | | |
| 472 | 192.01 | | | | |
| 473 | 192.21 | | | | |
| 474 | 192.41 | | | | |
| 475 | 192.61 | | | | |
| 476 | 192.81 | | | | |
| 477 | 193.02 | | | | |
| 478 | 193.22 | | | | |
| 479 | 193.42 | | | | |
| 480 | 193.62 | | | | |
| 481 | 193.82 | | | | |
| 482 | 194.02 | | | | |
| 483 | 194.22 | | | | |
| 484 | 194.42 | | | | |
| 485 | 194.62 | | | | |
| 486 | 194.82 | | | | |
| 487 | 195.02 | | | | |
| 488 | 195.22 | | | | |
| 489 | 195.42 | | | | |

USACERL DISTRIBUTION

Chief of Engineers
 ATTN: CEHEC-IM-LH (2)
 ATTN: CEHEC-IM-LP (2)
 ATTN: CECG
 ATTN: CECC-P
 ATTN: CECC-R
 ATTN: CECW
 ATTN: CECW-O
 ATTN: CECW-P
 ATTN: CECW-PR
 ATTN: CEMP
 ATTN: CEMP-E
 ATTN: CEMP-C
 ATTN: CEMP-M
 ATTN: CEMP-R
 ATTN: CERD-C
 ATTN: CERD-ZA
 ATTN: CERD-L
 ATTN: CERD-M
 ATTN: CERM
 ATTN: DAEN-ZC
 ATTN: DAIM-FDP

CECPW 22310-3862
 ATTN: CECPW-E
 ATTN: CECPW-FT
 ATTN: CECPW-ZC

SERDP

US Army Engr District
 ATTN: Library (40)

US Army Engr Division
 ATTN: Library (11)

INSCOM
 ATTN: IALOG-I 22060
 ATTN: IAV-DPW 22186

USA TACOM 48397-5000
 ATTN: AMSTA-XE

Defense Distribution Region East
 ATTN: ASCE-WI 17070-5001

Defense Distribution Region West
 ATTN: ASCW-WG 95296-0100

HQ XVIII Airborne Corps 28307
 ATTN: AFZA-DPW-EE

4th Infantry Div (MECH) 80913-5000
 ATTN: AFZC-FE

US Army Materiel Command (AMC)
 Alexandria, VA 22333-0001
 ATTN: AMCEN-F
 Installations: (20)

FORSCOM
 Forts Gillem & McPherson 30330
 ATTN: FCEN
 Installations: (20)

6th Infantry Division (Light)
 ATTN: APVR-DE 99505
 ATTN: APVR-WF-DE 99703

TRADOC
 Fort Monroe 23651
 ATTN: ATBO-G
 Installations: (20)

Fort Belvoir 22060
 ATTN: CETEC-IM-T
 ATTN: CETEC-ES 22315-3803
 ATTN: Water Resources Support Ctr

USA Natick RD&E Center 01760
 ATTN: STRNC-DT
 ATTN: AMSSC-S-IMI

US Army Materials Tech Lab
 ATTN: SLCMT-DPW 02172

USARPAC 96858
 ATTN: DPW
 ATTN: APEN-A

SHAPE 09705
 ATTN: Infrastructure Branch LANDA

Area Engineer, AEDC-Area Office
 Arnold Air Force Station, TN 37389

HQ USEUCOM 09128
 ATTN: ECJ4-LIE

AMMRC 02172
 ATTN: DRXMR-AF
 ATTN: DRXMR-WE

CEWES 39180
 ATTN: Library

CECRL 03755
 ATTN: Library

USA AMCOM
 ATTN: Facilities Engr 21719
 ATTN: AMSMC-EH 61299
 ATTN: Facilities Engr (3) 85613

USAARMC 40121
 ATTN: ATZIC-EHA

Military Traffic Mgmt Command
 ATTN: MTEA-GB-EHP 07002
 ATTN: MT-LOF 20315
 ATTN: MTE-SU-FE 28461
 ATTN: MTW-IE 94626

Fort Leonard Wood 65473
 ATTN: ATSE-DAC-LB (3)
 ATTN: ATZT
 ATTN: ATSE-CFLO
 ATTN: ATSE-DAC-FL
 ATTN: Australian Liaison Office

Military Dist of WASH
 Fort McNair
 ATTN: ANEN 20319

USA Engr Activity, Capital Area
 ATTN: Library 22211

US Army ARDEC 07806-5000
 ATTN: AMSTA-AR-IMC

Engr Societies Library
 ATTN: Acquisitions 10017

Defense Nuclear Agency
 ATTN: NADS 20305

Defense Logistics Agency
 ATTN: MMDIS 22060-6221

Walter Reed Army Medical Ctr 20307

National Guard Bureau 20310
 ATTN: NGB-ARI

US Military Academy 10996
 ATTN: MAEN-A
 ATTN: Facilities Engineer

ATTN: Geography & Envr Engrg

Naval Facilities Engr Command
 ATTN: Facilities Engr Command (8)
 ATTN: Division Offices (11)
 ATTN: Public Works Center (8)
 ATTN: Naval Constr Battalion Ctr 93043
 ATTN: Naval Facilities Engr Service Center 93043-4328

8th US Army Korea
 ATTN: DPW (11)

USA Japan (USARJ)
 ATTN: APAJ-EN-ES 96343
 ATTN: HONSHU 96343
 ATTN: DPW-Okinawa 96376

416th Engineer Command 60623
 ATTN: Gibson USAR Ctr

US Army HSC
 Fort Sam Houston 78234
 ATTN: HSLO-F
 Fitzsimons Army Medical Ctr
 ATTN: HSHG-DPW 80045

Tyndall AFB 32403
 ATTN: HQAFCEA/CES
 ATTN: Engrg & Srvc Lab

USA TSARCOM 63120
 ATTN: STSAS-F

American Public Works Assoc. 64104-1806

US Army CHPPM
 ATTN: MCHB-DE 21010

US Gov't Printing Office 20401
 ATTN: Rec Sec/Deposit Sec (2)

Nat'l Institute of Standards & Tech
 ATTN: Library 20899

Defense General Supply Center
 ATTN: DGSC-WI 23297-5000

Defense Construction Supply Center
 ATTN: DCSC-WI 43216-5000

Defense Tech Info Center 22060-6218
 ATTN: DTIC-O (2)