

ARMY TM 5-628

AIR FORCE AFR 91-44

TECHNICAL MANUAL

RAILROAD TRACK STANDARDS

APPROVED FOR PUBLIC RELEASE; DISTRIBUTION IS UNLIMITED

DEPARTMENTS OF THE ARMY, AND THE AIR FORCE

APRIL 1991

TECHNICAL MANUAL
TM 5-628
AIR FORCE REGULATION
AFR 91-44



HEADQUARTERS
DEPARTMENT OF THE ARMY
AND THE AIR FORCE
WASHINGTON, DC, 8 April 1991

RAILROAD TRACK STANDARDS

		<i>Paragraph</i>	<i>Page</i>
CHAPTER	1. INTENT AND APPLICATION		
	Purpose	1-1	1-1
	Introduction	1-1	1-1
	References	1-2	1-1
	Intent	1-3	1-1
	Track categories	1-4	1-1
	Application	1-5	1-1
CHAPTER	2. INSPECTION OF TRACK AND RECORDKEEPING		
	Inspection by qualified inspectors	2-1	2-1
	Inspection frequencies	2-2	2-1
	Special <i>inspections</i>	2-3	2-1
	Responsibilities of inspectors	2-4	2-1
	Inspection of partially visible track	2-5	2-1
CHAPTER	3. ROADWAY		
	Roadway	3-1	3-1
	Drainage	3-2	3-1
	Vegetation	3-3	3-1
CHAPTER	4. BALLAST		
	General	4-1	4-1
	Selection criteria	4-2	4-1
	Maintenance	4-3	4-2
CHAPTER	5. TIES		
	General	5-1	5-1
	Identification of defective ties	5-2	5-1
	Tie requirements	5-3	5-2
CHAPTER	6. TIE PLATES, RAIL FASTENINGS, AND OTHER TRACK MATERIALS		
	General	6-1	6-1
	Tie plates	6-2	6-1
	Spikes	6-3	6-1
	Joints	6-4	6-3
	Rail anchors	6-5	6-4
	Gage rods	6-6	6-5
CHAPTER	7. RAIL		
	Defective rail and remedial actions	7-1	7-1
	Rail maintenance	7-2	7-3
	Lightweight rail	7-3	7-3
CHAPTER	8. TURNOUTS		
	General	8-1	8-1
	General requirements	8-2	8-1
	Switches and switch stands	8-3	8-2
	Frogs	8-4	8-4
	Guard rails	8-5	8-6
CHAPTER	9. RAIL CROSSINGS		
	General	9-1	9-1
	Requirements	9-2	9-1
	Anchors	9-3	9-1
CHAPTER	10. ROAD CROSSINGS		
	Drainage	10-1	10-1
	Flangeways	10-2	10-1
	Track	10-3	10-1
	Crossing surfaces and materials	10-4	10-2

TM 5-628/AFR 91-44

		<i>Paragraph</i>	<i>Page</i>
	Crossing protection	10-5	10-2
CHAPTER	11. BRIDGES		
	General	11-1	11-1
	Bridge inspection	11-2	11-1
	Dangerous conditions	11-3	11-1
CHAPTER	12. TRACK GEOMETRY		
	General	12-1	12-1
	Gage	12-2	12-1
	Crosslevel	12-3	12-2
	Superelevation	12-4	12-2
	Warp	12-5	12-3
	Alinement	12-6	12-4
	Profile	12-7	12-5
CHAPTER	13. CLEARANCES		
	Measurement	13-1	13-1
	Clearance requirements, tangent track	13-2	13-1
	Clearance requirements, curved track	13-3	13-2
	Track centers	13-4	13-3
	Changes to clearances	13-5	13-3
CHAPTER	14. MISCELLANEOUS TRACK APPLIANCES		
	Track scales	14-1	14-1
	Bonded and grounded track	14-2	14-1
	Derails	14-3	14-1
CHAPTER	15. TRACK MAPS		
	General	15-1	15-1
	Criteria	15-2	15-1
CHAPTER	16. MAINTENANCE ACTIVITIES FOR CATEGORY "C" TRACK		
	Section I. Army		
	General	16-1	16-1
	Maintenance requirements	16-2	16-1
	Inactivation and disposal	16-3	16-1
	Section II. Air Force		
	General	16-4	16-1
	Maintenance requirements	16-5	16-1
	Disposal	16-6	16-1
APPENDIX A.	REFERENCES		<i>Page</i> A-1
APPENDIX B.	FIELD IDENTIFICATION OF RAIL DEFECTS		B-1
APPENDIX C.	DETAILS OF RAIL SECTIONS		C-1
APPENDIX D.	SUMMARY OF STANDARDS REQUIREMENTS, DEFECTS, AND RESTRICTIONS		D-1

List of Figures

<i>Figure No.</i>		<i>Page</i>
5-1.	Examples of good and defective ties	5-2
5-2.	Required tie support at joints	5-2
6-1.	Single shoulder tie plate	6-1
6-2.	Double shoulder tie plate	6-1
6-3.	Spiking pattern for tangents and curves less than 4 degrees	6-2
6-4.	Spiking pattern for curves 4 degrees and greater	6-2
6-5.	Spiking through angle bars	6-3
6-6.	Proper bolt installation	6-4
6-7.	Recommended minimum anchoring pattern	6-5
7-1.	Rail wear measurement	7-2
7-2.	Rail base corrosion measurement	7-2
7-3.	End batter measurement	7-3
8-1.	Parts of a turnout	8-1
8-2.	Reversing tangent length and switch stand placement	8-2
8-3.	Switch point contour	8-2
8-4.	Switch point plan and elevation	8-3
8-5.	Frog point and tread contours	8-4
8-6.	Allowable wear on guarding face of self-guarded frog	8-4

List of Figures—Continued

<i>Figure No.</i>		<i>Page</i>
8-7.	Measurement of flangeway width, flangeway depth, guard check gage, and guard face gage	8-6
10-1.	Track construction for road crossing	10-1
12-1.	Gage measurement	12-1
12-2.	Required gage measurement locations within turnouts	12-1
12-3.	Crosslevel measurement	12-2
12-4.	Determination of warp	12-4
12-5.	Measurement of curve alinement	12-5
13-1.	Minimum clearances for tangent track	13-1
B-1.	Common rail nonmenclature	B-1
B-2.	Relative positions of planes through a rail	B-1
B-3.	General appearance of bolt hole cracks	B-2
B-4.	General appearance of broken base	B-2
B-5.	General appearance of broken rail	B-3
B-6.	General appearance of corrugation	B-3
B-7.	General appearance of crushed head	B-3
B-8.	Rail end batter	B-4
B-9.	Typical appearance of an engine burn	B-4
B-10.	General appearance of an engine burn fracture	B-5
B-11.	General appearance of flaking	B-5
B-12.	General appearance of flow	B-6
B-13.	General appearance of head/web separation	B-6
B-14.	General appearance of horizontal split head	B-7
B-15.	General appearance of mill defects	B-7
B-16.	General appearance of piped rail	B-7
B-17.	Cross-sectional view of piped rail	B-8
B-18.	General appearance of vertical head and side wear	B-8
B-19.	General appearance of shelling	B-8
B-20.	General appearance of slivers	B-9
B-21.	General appearance of split web	B-9
B-22.	General appearance of torch cut rail	B-9
B-23.	General appearance of traverse defects	B-10
B-24.	General appearance of vertical split head	B-10
C-1.	Details of rail sections	C-1

List of Tables

<i>Table No</i>		<i>Page</i>
4-1.	AREA recommended gradations for ballast	4-1
7-1.	Rail defects, operating restrictions, and remedial actions	7-1
7-2.	Recommended rail defect inspection frequencies	7-3
8-1.	Measurements and operating restrictions for frogs and guard rails	8-5
8-2.	Minimum length of straight guarding face in advance of frog point	8-6
12-1.	Recommended gage for curved track	12-2
12-2.	Superelevation for curved track	12-3
13-1.	Clearance requirements for tangent track	13-1
C-1.	Details of rail sections	C-1
D-1.	Summary of standards, requirements, defects, and restrictions	D-1

CHAPTER 1

INTENT AND APPLICATION

1-1. Introduction.

a. The Army's and the Air Force's railroad system is a critical asset for both peacetime and mobilization missions.

b. The standards contained herein are promulgated to protect investments in track maintenance and rehabilitation and to ensure that Army and Air Force track is maintained at the level needed to support mission requirements.

c. Simply meeting the minimum standard required herein is not necessarily the best, most cost effective, long-term maintenance policy. The frequent occurrence of substandard or restricted conditions indicates the need for a comprehensive track evaluation to determine if major repair or rehabilitation is warranted.

1-2. References. Appendix A contains a list of references used in this document.

1-3. Intent.

a. These standards define the *minimum* required condition levels for Army and Air Force railroad track. For Army railroads, these standards shall be used for the inspection and routine maintenance of Army railroad track by in-house or contract personnel as prescribed in AR 420-72. For Air Force railroads, these standards shall be used for the inspection and routine maintenance of Air Force railroad track by in-house or contract personnel.

b. These standards are not intended for, and shall not be used as specifications for new construction or major track rehabilitation. The guidance given in TM 5-850-2/AFM 88-7, Chap. 2 and the American Railway Engineering Association (AREA) "Manual for Railway Engineering" and/or host nation industry/government standards will continue to apply to new construction and to the complete reconstruction of segments of existing facilities.

c. Should the commercial carrier serving the installation require a more restrictive standard or criteria not included in these standards, the installation track shall be maintained to meet the carrier's requirements.

d. The judgement of the certified track inspector

and the criteria presented herein must supplement each other in the application of these standards. *

1-4. Track categories.

All Army and Air Force track shall be maintained in accordance with one of the following categories:

<i>Track Category</i>	<i>Types of Track</i>
A	Active main lines Any track where the operating speed exceeds 10 miles per hour (mph) Track (both active and inactive) required for mobilization and where the operating speed will exceed 10 miles per hour (mph)
B	Active passing tracks, loading tracks, classification yard tracks, and storage tracks All other tracks (both active and inactive) required for mobilization that are not previously identified as Category A track Tracks having an occasional use or a foreseeable need
C	Inactive track with no current mission requirements

1-5. Application.

a. Requirements versus recommendations. In this manual the words "shall" and "is required" indicate requirements of the standards which must be met as prescribed by Army AR 420-72 and this AFR. Recommendations are indicated by the words "may", "should", and "it is recommended that . . .". These recommendations represent good maintenance practice.

b. Condition levels. These standards establish four levels of track condition. These condition levels indicate relative seriousness of defects, allow comparison of different types of defects, and provide a means for prioritizing repair work. The four track condition levels are as follows:

(1) Full compliance—Track that meets all the requirements of the standards. Track at this level has, at most, only minor defects and should be fully capable of handling all train operations within the operating rules of the installation. Routine

* For Air Force users: throughout this regulation, substitute "qualified track inspector" where the text reads "certified track inspector." The Air Force has not established a training and certification program at this time. See paragraph 2-1 for details.

TM 5-628/AFR 91-44

maintenance is required to maintain this condition level, and repair work will generally be only minor.

(2) 10 mph—Track has defects serious enough to make it unsuitable for operations greater than 10 mph, essentially “normal yard speed”. Track at this condition level would be considered “marginal”.

(3) 5 mph—Track has defects serious enough to make it unsuitable for operations greater than 5 mph. Essentially, a train may be allowed to “crawl” over the track. This level is intended as a warning zone to indicate that the track is approaching a condition that will require removal from service.

(4) No operation—Track has defects serious enough to require removal from service. At this level, the operation of trains over the track is generally considered hazardous. Operations shall not be allowed except as noted in paragraph 1-5d(5).

c. Minimum required condition levels. The minimum required condition levels for Army and Air Force track are:

<i>Track Category</i>	<i>Minimum Required Condition Level</i>
A	Full compliance
B	10mph
C	Maintenance as per chapter 16 of these standards

For Army track these minimum required condition levels are established by AR 420—72.

d. *Operating restrictions.*

(1) These standards establish minimum required condition levels for Army and Air Force track and also identify track conditions requiring restriction or suspension of train operations. It is intended that a track inspector apply the required restriction or suspension immediately upon discovery of the substandard condition, and that the track be repaired to meet the appropriate condition level as soon as practical.

(2) Notification of track restriction. For Army track, the certified track inspector shall notify both the train operating personnel and the Director of Engineering and Housing (DEH) immediately upon the discovery of any condition which would warrant a restriction beyond normal operating practices or a suspension in operations. The DEH shall notify the Installation Transportation Officer (ITO) verbally and in writing of any condition requiring train operations to be restricted beyond normal operating practices or suspended. For Air Force track, the track inspector shall notify both the train operating personnel and the Base Civil Engineer (BCE) immediately upon the discovery of

any condition which would warrant a restriction beyond normal operating practices or a suspension in operations. The BCE shall notify the Base Traffic Management Officer (TMO) verbally and in writing of any condition requiring train operations to be restricted beyond normal operating practices or suspended.

(3) *Operations over restricted track.* For locations ‘where operating restrictions have been imposed, the speed of the train or other on-track vehicle shall be reduced to the required level before the first wheel reaches the defective area and not increased until the last wheel has passed the defective area.

(4) *Removal of track restriction.* A track restriction may be removed after all defects resulting in the restriction have been repaired. For Army track, the certified track inspector shall notify the DEH upon completion of the repairs. The DEH shall notify the ITO in writing that the restrictions have been lifted. The restriction shall not be considered removed until the ITO receives written notification of removal from the DEH. For Air Force track, the track inspector shall notify the BCE upon completion of the repairs. The BCE shall notify the TMO in writing that the restrictions have been lifted. The restriction shall not be considered removed until the TMO receives written notification of removal from the BCE.

(5) *Track removed from service.* Any portion of track where conditions fall below the minimum operable track condition (track condition is at the No Operation level) shall be closed to operations until repairs are completed. However, such track may be used under written permit from the DEH (BCE) and in the presence of a certified track inspector. During operations over the closed portion of track the certified track inspector shall have visual contact with the train operator at all times and be prepared to signal the train crew to stop.

(6) Any deficiency in Category A track requiring the track to be removed from service should be corrected within 30 days of discovery.

e. Judgment of the certified track inspector shall govern. A certified track inspector shall have the authority to impose operating restrictions beyond the minimum required in these standards when conditions warrant.

f. Defective conditions not addressed in these standards. Defective conditions or combinations of conditions may be found which are not directly addressed in these standards. In such cases, a certified track inspector shall exercise judgment in applying an appropriate operating restriction.

CHAPTER 2

INSPECTION OF TRACK AND RECORD KEEPING

2-1. Inspection by qualified inspectors.

a. Army track. For Army track, the individual who completes the required track inspections shall be a certified track inspector as specified in AR 420-72.

b. Air Force track. For Air Force track, the individual who completes the required track inspections shall be qualified to perform such inspections as designated by the BCE.

2-2. Inspection frequencies.

a. Category A and Category B track. As a minimum, track designated as either Category A or Category B shall be inspected at the intervals shown below:

<i>Traffic Frequency</i>	<i>Minimum Required inspection Frequency</i>
Two or more movements per week	Once every month
Greater than one movement per month but less than two move- ments per week.	Once every 2 months
Less than one movement per month	Once every 6 months

b. Category C track. Category C track shall be inspected annually in accordance with chapter 16 of these standards.

c. Electric/electromechanical grade crossing signals. The inspection of electric/electromechanical signals at road-railroad grade crossings shall be performed at the same frequency as track inspections (para 2-2a); however, inspections of signals shall be performed not less than once per quarter (at approximately 3 month intervals). See chapter 10 for additional information on the inspection of these signals.

d. Internal rail defect inspection. Internal rail defect inspection shall be performed every 3 to 6 years as specified in paragraph 7-2b.

2-3. Special inspections.

a. Infrequently used track. Track that has not been used for a period of 6 months or more shall be inspected prior to the first movement over the track.

b. Mass rail movement. For track that has not been inspected within the last 2 months, a track inspection is recommended prior to any mass rail movement (50 cars or more).

c. Unusual occurrences. Track inspections shall be conducted following unusual occurrences such as a derailment, accident, flood, fire, earthquake,

severe storm, or other occurrence which could have an adverse effect on the track structure. These inspections shall be conducted prior to the first movement over the track following the unusual occurrence.

2-4. Responsibilities of inspectors.

a. The certified track inspector is responsible for:

(1) Assuring that inspections of Army and Air Force track are performed in accordance with paragraphs 2-2, 2-3, 2-4, and 2-5 of these standards.

(2) Examining the track to determine whether the track condition complies with the requirements of these standards.

(3) Reporting any deviations from the full compliance condition level.

b. Track inspections prescribed in paragraphs 2-2 and 2-3 shall be made on foot or in an on-track vehicle at a speed which is conducive to effective track inspection, but in no case to exceed 5 mph. Turnouts, road crossings, rail crossings, bridges, and drainage structures shall be inspected on foot.

c. The inspector shall complete and keep a copy of this inspection on file for at least 3 years. Inspection reports which document deficiencies resulting in a track falling below its designated condition level shall be kept on file until all those deficiencies have been corrected.

2-5. Inspection of partially visible track.

a. At locations where vegetation, dirt, debris, or other undesirable materials cover the ties and/or rail preventing effective track inspection, train operations shall not exceed 10 mph until the undesirable materials are removed and a thorough track inspection is performed.

b. Paved areas. In road crossings and other paved areas where complete inspection of the track is not possible, the certified track inspector must be alert for external signs of track deterioration. External signs indicating track deterioration are:

(1) Changes in gage and/or crosslevel.

(2) Settlement of the rails (changes in track profile).

(3) Excessive vertical movement of the rails as a train passes.

(4) Settlement of the pavement in the vicinity of the track.

TM 5-628/AFR 91-44

(5) Deterioration (cracking or breaking up) of the pavement in the vicinity of the track.

c. Operating restrictions for track in pavement. When external signs of track deterioration develop, particular attention should be given to the track geometry measurements through the paved area. Track geometry measurements, combined with visual indications of lateral and vertical movement,

and the requirements for road crossing flangeways shall be used to assign operating restrictions for the track through the paved area. Operating restrictions shall be consistent with the operating restrictions required for road crossings and for track geometry deviations given in chapters 10 and 12 of these standards.

CHAPTER 3

ROADWAY

3-1. Roadway.

a. Inspection. The roadway shall be inspected for the following defects:

- (1) Ballast/subgrade pumping.
- (2) Erosion of embankments and cut slopes.
- (3) Embankment sliding or slippage.
- (4) Potential slope stability problems.
- (5) Settlement at approaches to bridge ends.
- (6) Washouts under the track.

If any of these are present, remedial action is required within a time frame necessary to prevent damage to the track structure.

b. Hazardous conditions. Any condition presenting a hazard to the safe movement of trains shall be corrected prior to the first movement over that location.

3-2. Drainage.

a. General.

(1) A well-drained roadbed is essential to good track maintenance.

(2) Any attempts to divert water onto the roadway or to obstruct ditches or drainage structures shall be reported immediately to the DEH (BCE).

(3) Drains, ditches, and other open drainage structure shall be protected to prevent hazards to personnel.

b. Size and design. Ditches and other drainage structures (culverts, drains, and drop inlets) shall be of sufficient size and construction to handle the expected flow of water, in accordance with TM 5-820-4/AFM 88-5, Chap. 4.

c. Obstructions. Ditches and drainage structures shall be maintained to allow the free passage of water. At locations where flow is obstructed or otherwise inadequate, remedial action is required. During construction operations adjacent to the track structure all ditches and other drainage structures shall be kept unobstructed.

d. Inspection.

(1) Inspection and cleaning of drainage structures and channels shall be performed at least annually.

(2) Inspections of ditches and other drainage structures during and after heavy rains are recommended to ensure that these structures are adequate to carry the runoff.

(3) Drainage ditches and structures shall be inspected for the presence of:

- (a) Brush.
- (b) Drift
- (c) Excessive ice and snow.

(d) Other obstructions which may interfere with the flow of water.

If any of these are present, immediate remedial action is required to prevent damage to the roadway and track structure.

(4) Particular attention shall be given to drainage conditions at turnouts, rail crossings, road crossings, bridge ends, and all locations where conditions may restrict adequate drainage.

3-3. Vegetation.

a. Vegetation shall be controlled so that it does not:

(1) Grow within the ballast section or obstruct ballast drainage.

(2) Interfere with adequate visibility at grade crossings.

(3) Obstruct visibility of location markers, switch position indicators, signs, or signals.

(4) Obstruct drainage.

(5) Interfere with the safe operation of trains.

(6) Prevent proper track inspection.

(7) Present a fire hazard to timber structures.

(8) Interfere with personnel walking within 8 feet of the track centerline.

(9) Brush the sides of rolling stock.

b. Vegetation interference.

(1) At locations where vegetation interferes with the effective inspection of the track, train operations shall not exceed 10 mph until the vegetation is removed and a thorough track inspection is performed.

(2) At locations where vegetation interferes with train operations, operations shall not exceed 5 mph until the vegetation is removed and an additional track inspection is performed.

c. Vegetation control. Undesirable vegetation growing within the roadway shall be removed by chemical or manual means. For Army Track, chemical vegetation control shall be accomplished as prescribed by AR 420-76, TM 5-629, and TM 5-630. For Air Force track, chemical vegetation control shall be accomplished as prescribed by AFR 91-21, and AFM 91-19.

TM 5-628/AFR 91-44

d. Desirable vegetation. Vegetation may be planted and grown on the slopes of cuts and fills and in other locations within the roadway to prevent

erosion. The growth of desirable vegetation should be controlled to meet the requirements of paragraph 3-3*a*.

CHAPTER 4

BALLAST

4-1. General. Ballast is a select material placed on the subgrade to:

a. Restrain the track laterally, longitudinally, and vertically under the dynamic loads imposed by trains and the thermal stresses induced in the rails by changing temperature.

b. Provide adequate drainage of the track.

c. Distribute the load of the track and trains to prevent overstressing the subgrade.

4-2. Selection criteria.

a. Considerations for selecting materials to be used as ballast include:

(1) Size and gradation.

(2) Shape (angularity).

(3) Weight.

(4) Strength.

(5) Durability.

(6) Cleanliness.

(7) Economics.

b. New ballast materials used in the maintenance of Army track shall meet the requirements specified in the *AREA Manual For Railway Engineering*, chapter 1, part 2, for the gradation requirements given in table 4-1.

Table 4-1. AREA recommended gradations for ballast

Size No.	Nominal Size Square Opening in.	Amounts Finer Than Each Sieve (Square Opening)							
		Percent by Weight							
		2-1/2 in.	2 in.	1-1/2 in.	1 in.	3/4 in.	1/2 in.	3/8 in.	No. 4
3	2 to 1	100	95-100	35-70	0-15		0-5		
4A	2 to 3/4	100	90-100	60-90	10-35	0-10		0-3	
4	1-1/2 to 3/4		100	90-100	20-55	0-15		0-5	
5	1 to 3/8			100	90-100	40-75	15-35	0-15	0-5

Note: Size Numbers 3, 4A, and 4 are typically mainline ballast materials. Size Number 5 is typically yard ballast material.
Copyright 1987, American Railway Engineering Association; used by permission.

Table 4-1. AREA recommended gradations for ballast.

4-3. Maintenance.

a. The ballast section should be clean, free-draining, and free of vegetation, soil (mud), and other foreign materials.

b. During major maintenance or track rehabilitation, dirty or fouled crushed stone or slag ballast meeting the requirements of paragraph 4-2*b* may be cleaned or reconditioned and reused.

c. Ballast materials shall not be allowed to cover or be at a level above the top of the ties.

CHAPTER 5

TIES

5-1. General.

a. The functions of a tie are to:

- (1) Maintain gage.
- (2) Maintain surface.
- (3) Maintain alinement.
- (4) Distribute the load from the rail to the ballast and subgrade.

The inability of a tie to adequately perform any of the above functions constitutes a defective tie.

b. Tie selection and treatment.

(1) *Tie selection.* New ties selected for use in the maintenance of Army track shall meet the requirements specified in the *AREA Manual For Railway Engineering*, chapter 8, part 1 for 6-inch grade and 7-inch grade ties. The preferred species for ties are the following hardwoods: Red Oak, White Oak, Hickory, Ash, Beech, and Gum. Where softwoods are used, the Pine and Fir species are preferred.

(2) *Treatment.* Ties shall be pressure treated in accordance with the most current version of American Wood-Preserver's Association (AWPA) Standard C6. As a general recommendation, the preferred preservative for ties is a creosote-coal tar solution (60/40) as specified in AWPA Standard P2, "Standard for Creosote and Creosote Solutions". For ties used West of the Mississippi River where attack of the wood by organisms such as fungi and termites is generally not as severe, a creosote-petroleum solution (50/50) as specified in AWPA

Standard P3, "Standard for Creosote-Petroleum Oil Solution" may be used.

(3) *Switch ties.* It is recommended that switch ties be hardwood selected from the list of preferred species given in paragraph 5-1b(1).

c. *Installation.* Ties shall be installed perpendicular to the rails and properly tamped and spiked. Ties shall be installed with the top of the tie (or the tie plate) in full contact with the base of the rail and the bottom of the tie near the rail seat in full contact with the ballast.

5-2. Identification of defective ties.

a. *Defective ties.* A tie is defective if it is:

- (1) Broken through.
- (2) Split or otherwise impaired to the extent that it will not hold spikes or other rail fasteners.
- (3) So deteriorated that the tie plate can move laterally more than $\frac{1}{2}$ (0.5) inch relative to the crosstie.
- (4) Cut by the tie plate more than 2 (2.00) inches.
- (5) Cut by wheel flanges, dragging equipment, fire, etc., to a depth of more than 2 (2.00) inches within 12 inches of the base of the rail, frog, or load-bearing area.
- (6) Rotted, hollow, or generally deteriorated to a point where a substantial amount of the material is decayed or missing. These defects are shown in figure 5-1.

TM 5-628/AFR 91-44

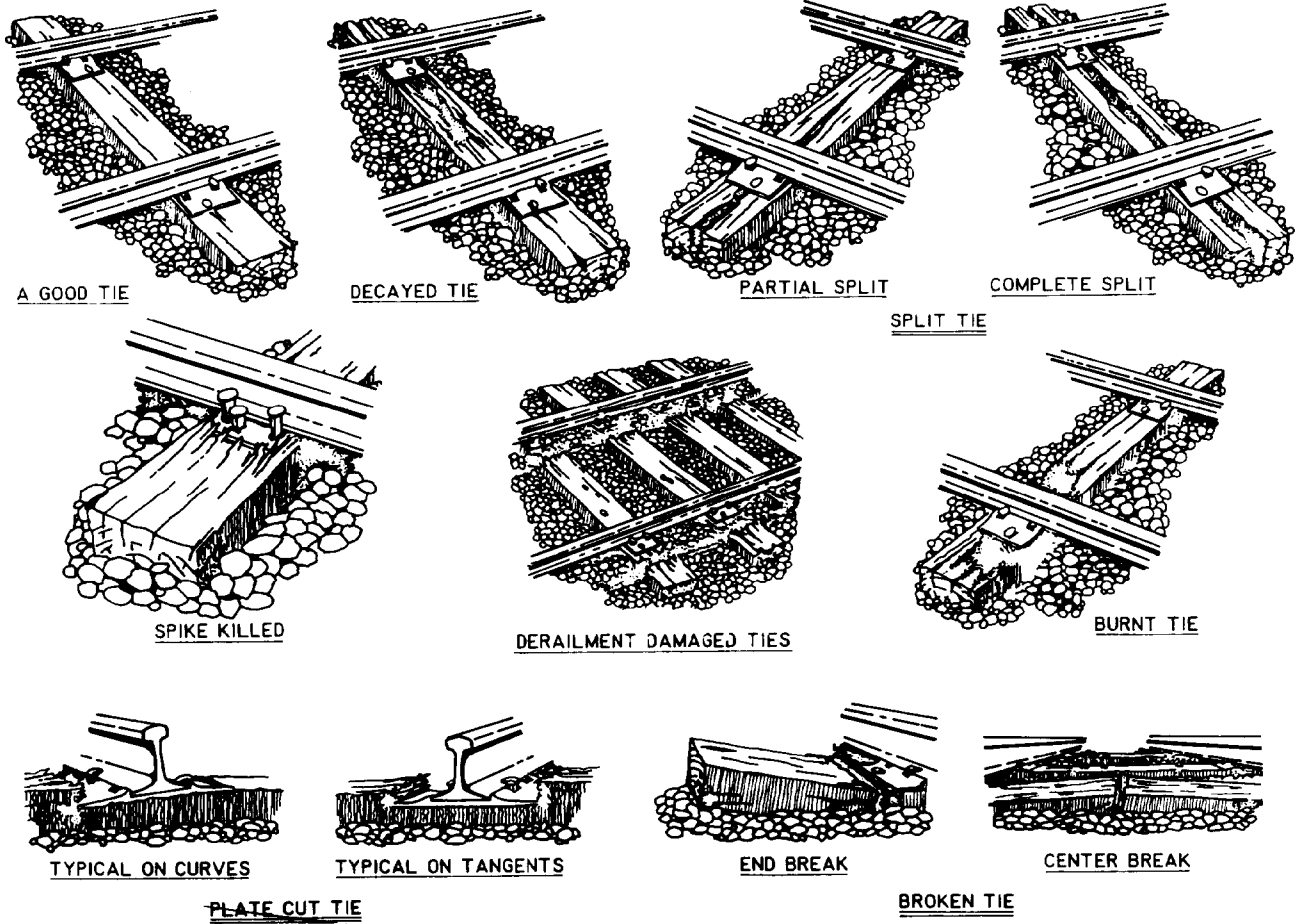

Figure 5-1. Examples of good and defective ties.

b. *Improper tie support (down or hanging ties).* Ties that do not support both rails are considered defective. If these down ties are not materially defective (see para 5-2a), they shall be tamped up and respiked to fully support the rails.

any location where a rail joint is not supported by at least one nondefective tie, operations shall not exceed 10 mph.

5-3. Tie requirements.

a. *Consecutive defective ties.* The occurrence of consecutive defective ties in Categories A and B track requires operating restrictions as specified below:

Number of Consecutive Defective ties	Operating Restrictions
0 to 2.....	None
3.....	Limit maximum speed to 10 mph
4.....	Limit maximum speed to 5 mph
5 or more	No operation

b. *Joint ties.* All joints shall be supported by at least one nondefective tie whose centerline is within 18 inches of the rail ends as shown in figure 5-2. At

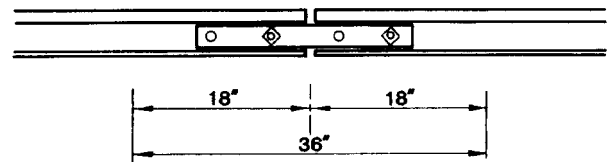

AT EACH JOINT, AT LEAST ONE TIE WITHIN THIS AREA MUST BE NON-DEFECTIVE.

Figure 5-2. Required tie support at joints.

c. *Tie spacing.* If the existing tie spacing averages greater than 22 inches within the distance of a rail length, the desired spacing should be established during the next major maintenance cycle. For track constructed with an average tie spacing greater than 22 inches, the desired spacing should be established during the next track rehabilitation.

d. Missing or skewed ties. Missing or skewed (crooked) ties are undesirable in track. At any location where the center-to-center tie spacing measured along either rail exceeds 48 inches, operations

shall not exceed 10 mph until additional tie support is provided, or skewed ties are straightened to reduce the spacing. Slightly skewed ties should be straightened during the next track rehabilitation.

CHAPTER 6

TIE PLATES, RAIL FASTENINGS, AND OTHER TRACK MATERIALS

6-1 General.

a. Tie plates, rail fastenings, and other track materials shall be the proper size and type as specified in TM 5-850-2/AFM 88-7, Chap. 2 and TM 5-627/AFM 91—33 and shall conform to the requirements of chapters 4 and 5 of the *AREA Manual For Railway Engineering*.

b. Tie plates, rail fastenings, and other track materials shall not be flame cut or otherwise altered.

c. Tie plates, rail fastenings, and other track materials which are of improper type, broken, or

otherwise defective shall be replaced with the proper size and type material.

6-2. Tie plates.

a. *Use.* Tie plates distribute the applied loads from the rail to the tie as well as assist in keeping the rail in position. Their use is especially important on curves where they provide additional lateral restraint.

b. *Type.* Tie plates may be of either the single shoulder type (fig 6-1) or the double shoulder type (fig 6-2).

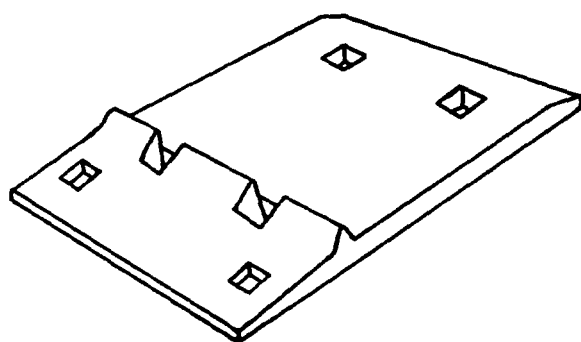

Figure 6-1. Single shoulder tie plate.

c. *Installation.* For track without tie plates, plates shall be installed during the next track rehabilitation or rail replacement.

6-3. Spikes

a. The rail shall have a sufficient number of fasteners (spikes) to effectively maintain gage and provide sufficient rail restraint.

b. *Spikes shall be:*

(1) Of proper size for the tie plates used.

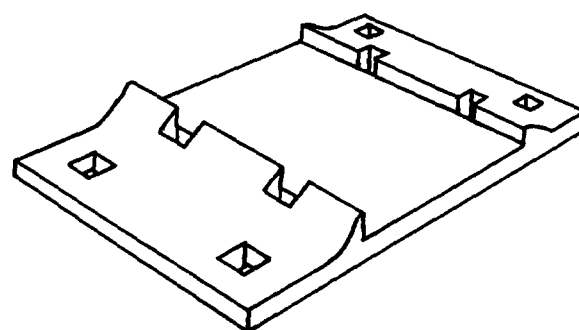

Figure 6-2. Double shoulder tie plate.

(2) Driven vertical and square with the rail.
 (3) Either of the cut or screw type.
 (4) Driven with approximately $\frac{1}{8}$ (0.125) inch of space remaining between the head of the spike and the base of the rail.

c. *Spiking pattern.*

(1) On tangent track and curves less than 4 degrees, spikes shall be installed as shown in figure 6-3.

TM 5-628/AFR 91-44

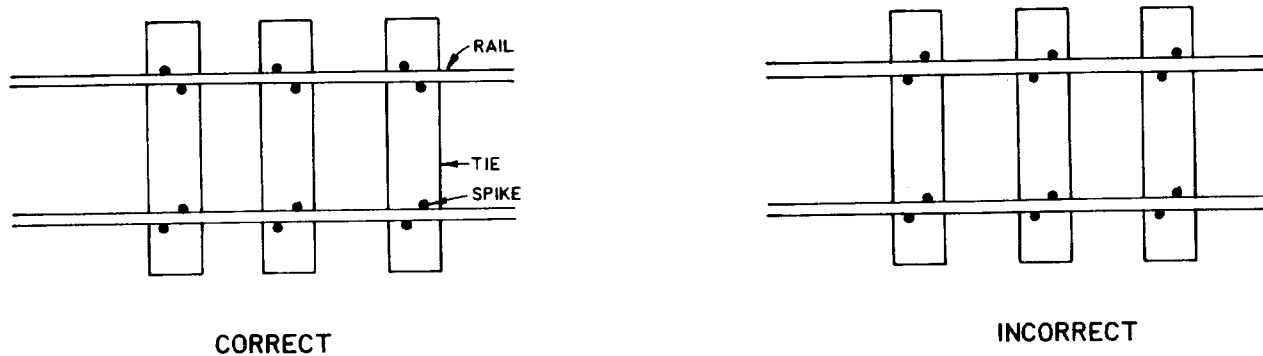

Figure 6-3. Spiking pattern for tangents and curves less than 4 degrees.

(2) On curves 4 degrees and greater and on the curved side of turnouts, the use of an additional spike as shown in figure 6-4 is recommended.

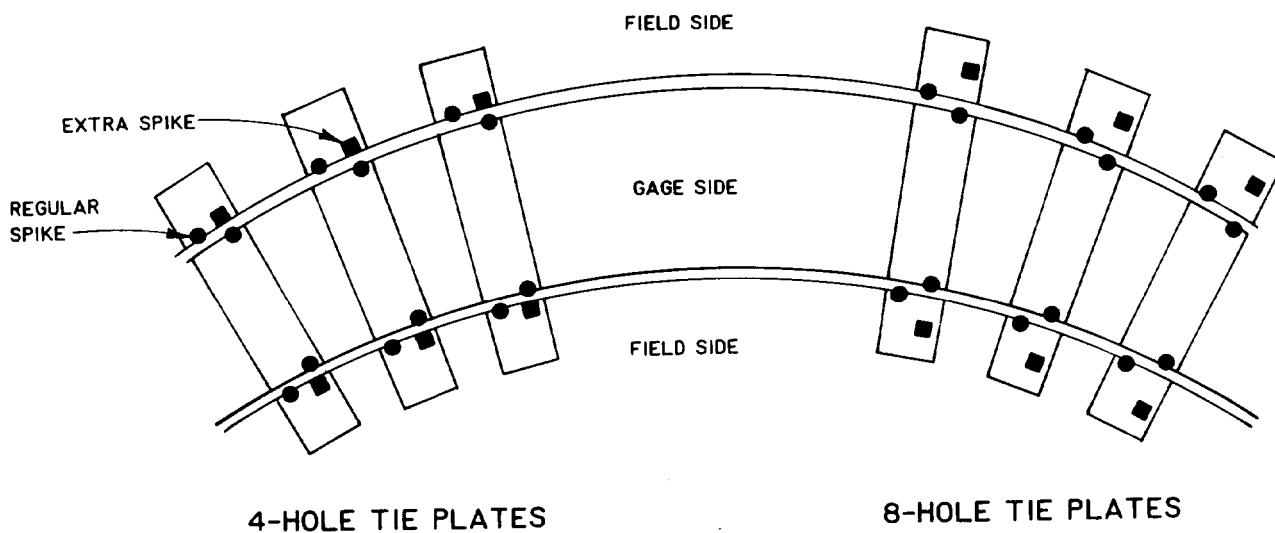

Figure 6-4. Spiking pattern for curves 4 degrees and greater.

(3) Spikes in angle bars. Spikes shall not be installed through the slots in skirted-type, slotted joint bars (angle bars) as shown in figure 6-5.

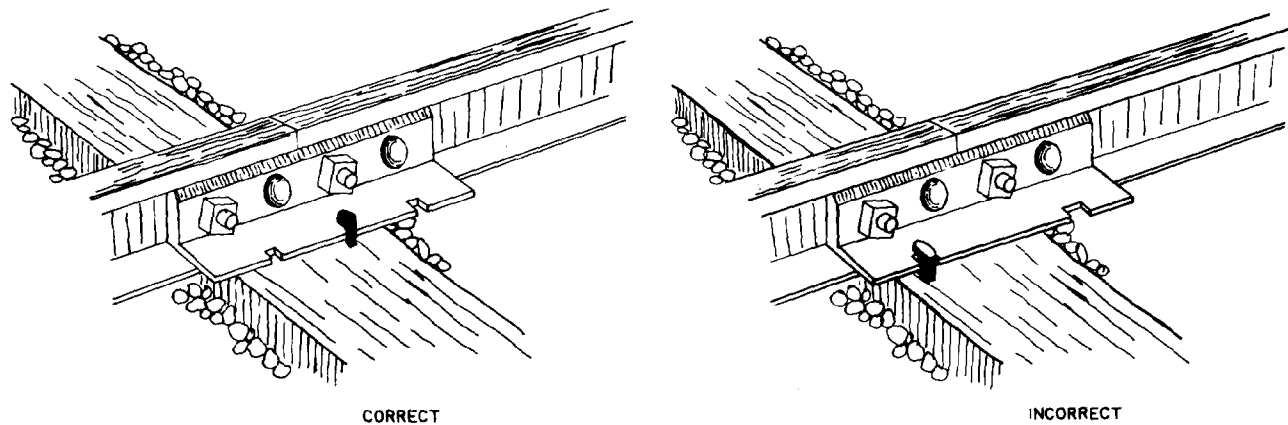

Figure 6-5. Spiking through angle bars.

(4) Correction on incorrect spiking patterns. An incorrect spiking pattern by itself is not a cause for removing and redriving spikes. However, an incorrect spiking pattern shall be corrected when other maintenance requires the spikes to be removed. Old spike holes shall be plugged to prevent accelerated tie deterioration.

d. Missing and loose spikes. Missing spikes shall be replaced. Old spike holes shall be plugged with a treated tie plug prior to replacing the spikes. Loose spikes shall be removed, the holes plugged, and the spikes redriven.

e. Spikes beneath rail base. Where the head of a spike has become lodged beneath the base of a rail, the spike shall be removed and properly redriven. A spike lodged beneath the rail base is an undesirable condition that can lead to a broken rail base.

6-4. Joints.

a. Joint bars. Rails shall be joined with proper factory designed and constructed joint bars. Joint bars may not be altered with a flame in any manner,

including the bolt holes. Joint bars not meeting these requirements shall be replaced.

b. Compromise joints. Rails of different size or section shall be joined with proper factory designed and constructed compromise bars, taper rails, or offset welds.

c. Cracked or broken joint bars. Cracked or broken joint bars shall be replaced.

(1) If one joint bar at a rail joint is cracked or broken between the center holes, operations over that location shall not exceed 10 mph.

(2) If both joint bars at a rail joint are cracked between the center holes, operations over that location shall not exceed 5 mph.

(3) Operations shall not be permitted over any location where both joint bars are broken, or where worn or loose joint bars allow vertical movement of either rail with respect to the other.

d. Bolts. Each joint shall be bolted with at least two bolts in each rail.

(1) All bolts shall be of proper size and tightly in place. A bolt is not considered tight unless the spring washer is compressed closed and is flat against the joint bar, as shown in figure 6-6.

TM 5-628/AFR 91-44

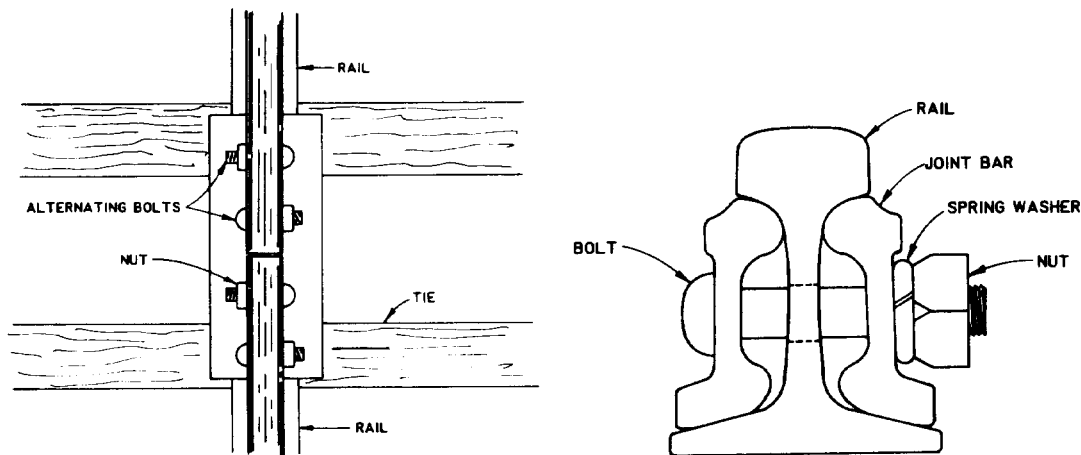

Figure 6-6. Proper bolt installation.

(2) Bolts which cannot be tightened shall be replaced. Missing bolts shall be replaced.

(3) Bolts shall be installed with spring lock washers. Nuts shall be installed against the spring lock washer as shown in figure 6-6. At least one full bolt thread shall extend past the outside of the nut.

(4) Bolts shall be installed so that the nuts will be alternately on the inside and outside of the rail as shown in figure 6-6.

(5) Whenever bolts and joint bars are removed, the rail in the joint area and the contact surfaces of the joint bar shall be cleaned (wire brushed) and lubrication applied to the joint bar and the bolt threads. New joint bars and bolts shall be lubricated before installation.

e. Loose and missing bolts.

(1) If all bolts at a joint are loose or if there is only one bolt through each rail, operations shall not exceed 10 mph.

(2) Operations shall not be permitted over locations where all bolts in one rail are missing.

f. Rail end mismatch.

(1) At any location where rail end mismatch exceeds $\frac{3}{16}$ (0.1875) inch on the tread portion or gage side of the rail, operations shall not exceed 10 mph.

(2) Operations shall not be permitted over locations where the rail end mismatch exceeds $\frac{1}{4}$ (0.25) inch.

g. Joint gap.

(1) At any location where the gap between rail ends exceeds 1 (1.00) inch, operations shall not exceed 10 mph.

(2) Operations shall not be permitted over locations where the gap exceeds 2 inches.

h. Joints in restricted areas. Whenever a joint is installed within 20 feet of a road crossing, the outer perimeter of any structure, or any location which restricts access to the joint, it is recommended that the joint be welded.

6-5. Rail anchors.

a. Rail anchors help prevent the longitudinal movement of rails commonly known as “running” or “creeping”. Rail anchors should be used at locations where the track is subject to serious movement from rail expansion or traffic conditions.

b. Rules for anchor application. General rules on the use of rail anchors are:

(1) Anchors shall be applied to the gage side of the rail against the same tie face on opposite rails.

(2) Anchors shall grip the base of the rail firmly and have full bearing against the face of the tie.

(3) When the bearing of the rail anchor against the tie has been disturbed by removal of the tie, the anchor shall be removed and reset.

(4) Anchors shall not be moved by driving them along the rail.

(5) Skewed ties shall be straightened before applying rail anchors.

Rail anchors not meeting requirements of paragraphs 6-5 *a* and *b* should be removed and reset.

c. Anchor locations.

(1) Where used, a minimum of eight anchors per 39 foot of rail is recommended as shown in figure 6-7. Additional anchors should be used as needed, and they should be installed four per tie with approximately uniform spacing along the rail.

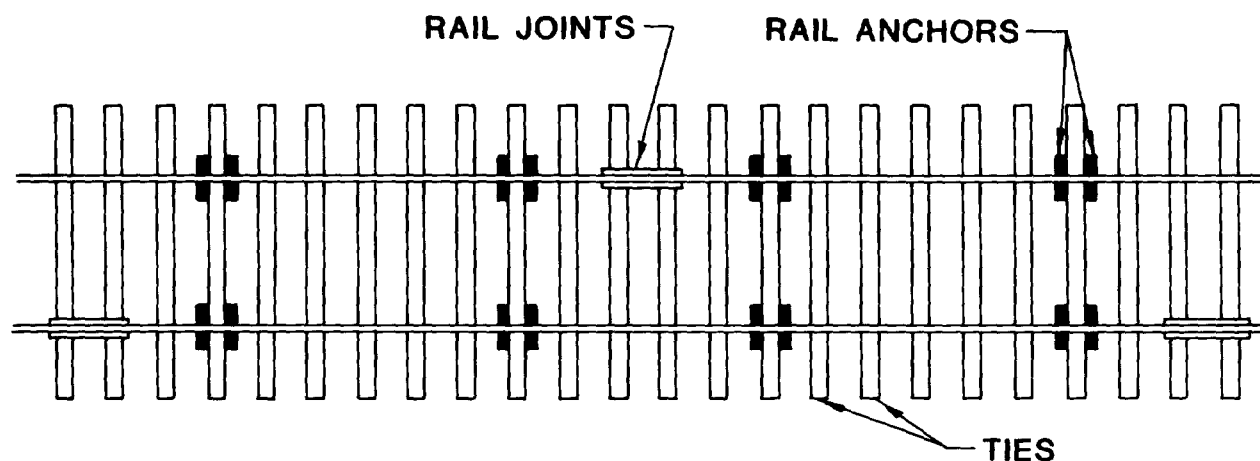

Figure 6-7. Recommended minimum anchoring pattern.

(2) *At open deck bridges.* Where anchors are used on track approaching open deck bridges, every third tie should be box anchored (four anchors per tie) for at least two rail lengths off each end of the bridge. No anchors shall be applied on the bridge itself.

(3) *At rail crossings.* Where anchors are used on track approaching rail crossings, every third tie should be box anchored (four anchors per tie) for at least two rail lengths in all directions from the crossing.

6-6. Gage rods.

a. Use. Gage rods are used to help maintain proper track gage but are not a substitute for good track maintenance and good tie conditions. Gage rods are sometimes used at the following locations:

(1) On sharp curves where there is difficulty holding the gage.

(2) In turnouts just ahead of the switch points and on the curved closure rails.

b. Spacing. Where gage rods are used in sharp curves, two to four rods should be installed for each rail length. Rods should be installed at evenly spaced intervals along the rail length.

c. Application. Gage rods should be installed at right angles to the rail with the jaws firmly gripping the base of the rail.

d. Maintenance.

(1) Gage rods shall be kept tight while maintaining the proper track gage.

(2) Bent or broken gage rods shall be replaced where the track conditions warrant their continued use.

CHAPTER 7

RAIL

7-1. Defective rail and remedial actions.

a. Remedial actions for rail defects are presented in table 7-1. Where rail defects have been identified but remedial action has not been completed,

the operating restrictions presented in table 7-1 shall apply. Appendix B provides brief descriptions of the common rail defects that may be observed in track.

Table 7-1
Rail Defects, Operating Restrictions, and Remedial Actions

Defect Type	Operating Restrictions Until Repairs Are Completed (Maximum Operating Speed)	Remedial Actions		
		Replace Entire Defective Rail	Crop Defect ^{2,3}	Apply Joint Bars (Fully Bolted)
Bolt hole crack	10 mph	Allowed	Allowed	--
Broken base	5 mph	Allowed	Allowed	Not allowed
Corrosion - greater than 1/4 inch	10 mph	REQUIRED	Not allowed	Not allowed
Complete break - clean and square	CLOSE TO TRAFFIC	Preferred	--	Allowed ³
Complete break - rough or angled	CLOSE TO TRAFFIC	Preferred	Allowed	Not allowed ⁴
Crushed head	10 mph	Preferred	Allowed	Not allowed
Defective weld	10 mph	Preferred	Preferred	Not allowed
End batter - greater than 1/4 inch	10 mph	Allowed	Allowed	--
Fissure - compound ⁵	CLOSE TO TRAFFIC	Preferred ¹	Allowed	Not allowed ⁴
Fissure - transverse ⁵	- Size less than 40% ⁶	5 mph	Allowed ¹	Allowed
	- Size greater than 40% ⁶	CLOSE TO TRAFFIC	Preferred ¹	Allowed
Fracture - detail ⁵	- Size less than 40% ⁶	5 mph	Allowed ¹	Allowed
	- Size greater than 40% ⁶	CLOSE TO TRAFFIC	Preferred ¹	Allowed
Fracture - engine burn ⁵	- Size less than 40% ⁶	5 mph	Allowed ¹	Allowed
	- Size greater than 40% ⁶	CLOSE TO TRAFFIC	Preferred ¹	Not allowed ⁴
Head/web separation	CLOSE TO TRAFFIC	REQUIRED	Not allowed	Not allowed
Piped rail	10 mph	REQUIRED	Not allowed	--
Running surface damage (depth greater than 1/4 inch)	10 mph	Allowed	Allowed	Not allowed
Short rail (rail less than 13 feet long)	NO RESTRICTION	REQUIRED	--	Not allowed
Split rail - horizontal	5 mph	REQUIRED	Not allowed	Not allowed
Split head - vertical	CLOSE TO TRAFFIC	REQUIRED	Not allowed	Not allowed
Split web	5 mph	REQUIRED	Not allowed	Not allowed
Torch cut - rail ends	10 mph	Preferred	Allowed	Not allowed
	bolt holes	5 mph	Preferred	Allowed
Wear on 90 lb or larger rail	Side wear greater than 1/2 inch	10 mph	REQUIRED ⁷	Not allowed
	Vertical wear greater than 1/2 inch	10 mph	REQUIRED	Not allowed
	Wear on rail less than 90 lb			
Side wear greater than 3/8 inch	10 mph	REQUIRED	Not allowed	Not allowed
	Vertical wear greater than 3/8 inch	10 mph	REQUIRED	Not allowed

Notes:

¹If two or more of these defects are found in any individual rail, that rail shall be replaced.

²Rails may be cropped by cutting the rail with a rail saw or other appropriate cutting tool, at least 6 inches either side of the defect.

³Not allowed if results in a rail length of less than 13 feet (See "Short Rail" below).

⁴May be allowed as an emergency measure until defect is removed provided operations are restricted to 5 mph and an inspector is present.

⁵If broken through or cracked out, rules for rough or angled complete break apply.

⁶Defect size estimated from internal rail flaw testing. If size is unknown, assume greater than 40%.

⁷90 lb or larger rail with wear on one side only may be transposed.

Table 7-1. Rail defects, operating restrictions, and remedial actions.

b. *Multiple defects.* Any individual rail having two or more of the fissure or fracture type defects listed in table 7-1, whether they are the same or different, shall be removed and replaced.

c. *Worn rails.* On rail suspected of being worn

more than the allowances provided for in table 7-1, wear measurements shall be taken at the center and at each end of the rail not more than 1 foot from the end of the joint bar. Rail wear measurements shall consist of a vertical head wear meas-

TM 5-628/AFR 91-44

urement and a side wear measurement as shown in figure 7-1. Table C-1 presents a table of details and properties for various rail sections. This table may

be used to assist in identifying rail sections and estimating the amount of rail wear.

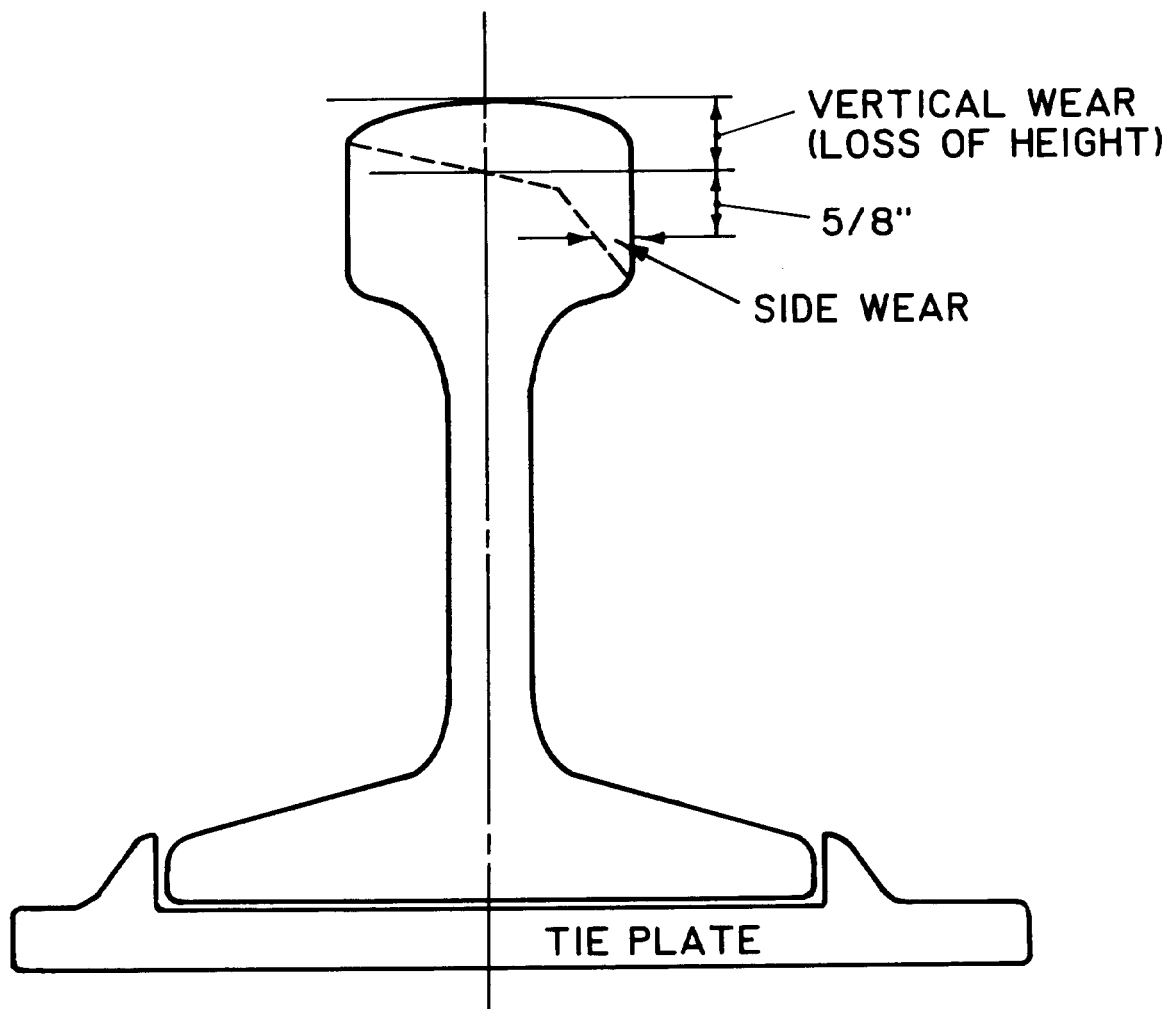

Figure 7-1. Rail wear measurement.

d. Base corrosion. Rail shall be removed from track if the base is corroded more than $\frac{1}{4}$ (0.25) inch as shown in figure 7-2.

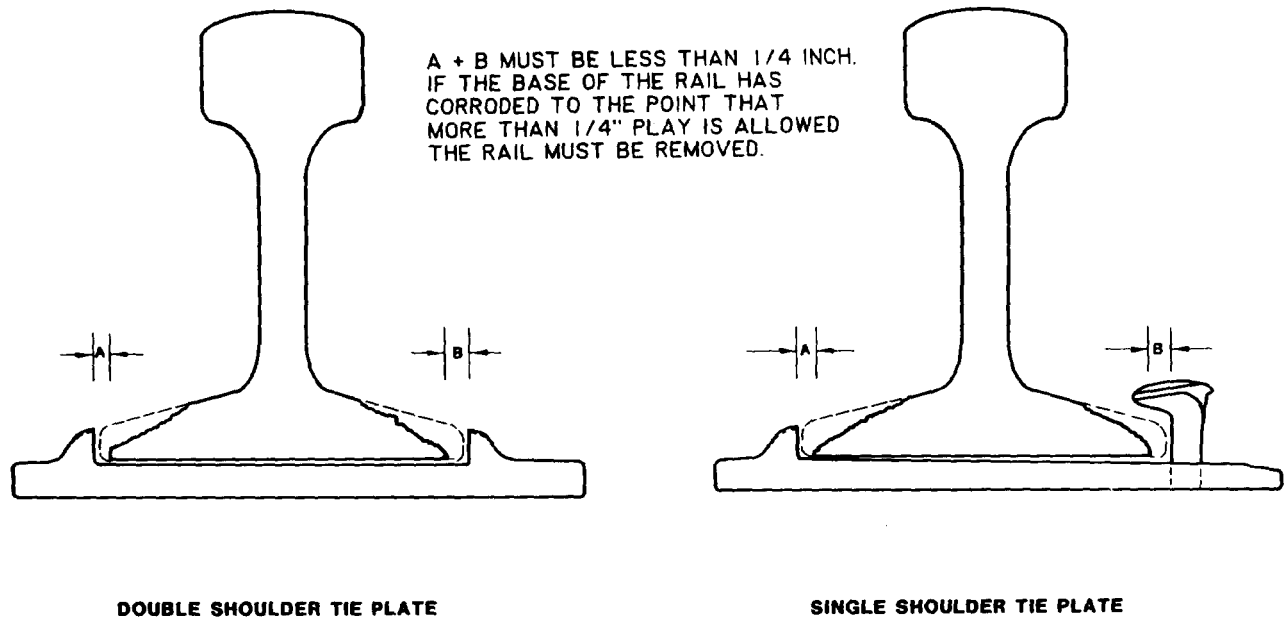

Figure 7-2. Rail base corrosion measurement.

e. End batter. Rail end batter is measured $\frac{1}{2}$ (0.50) inch from the rail end with an 18-inch straightedge laid only on the rail being measured

as shown in figure 7-3. Table 7-1 presents limits and remedial actions for end batter.

TM 5-628/AFR 91-44

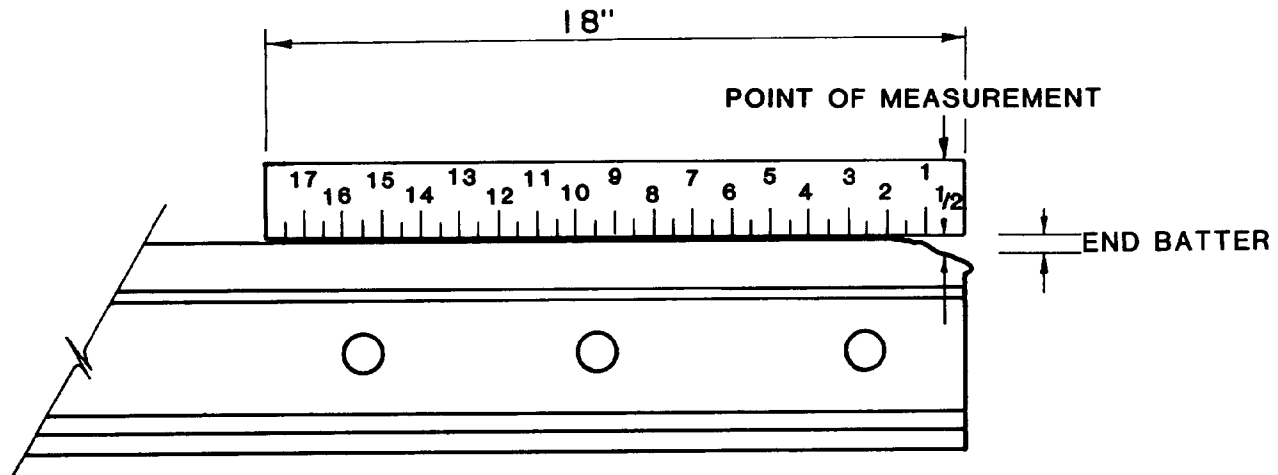

Figure 7-3. End batter measurement.

f. *Running surface damage.* Rail running surface damage, such as deep engine burns, dents, etc., is measured at the midpoint of an 18-inch straightedge laid on the railhead over the defect. Table 7-1 presents limits and remedial actions for rail surface damage.

7-2. Rail maintenance.

a. *Rail.* New rail used in the maintenance of Army and Air Force track shall meet the requirements specified in the *AREA Manual For Railway Engineering*, chapter 4.

b. *Internal defect inspection.* A "continuous search" internal rail defect inspection shall be performed at least once every 3 to 6 years on Categories A and B track. This internal rail defect inspection should be conducted using ultrasonic inspection techniques. Table 7-2 presents the recommended frequency for rail defect inspections.

Table 7-2. Recommended rail defect inspection frequencies

Annual Day-To-Day Traffic (Car Movements)	Inspection Frequency
1 million gross tons (MGT) or more (greater than 7,200 car movements per year).	3 years or 3 MGT, whichever is less
0.50 to 0.99 MGT (3,600 to 7,200 car movements per year).	5 years or 5 MGT, whichever is less
Less than 0.50 MGT (less than 3,600 car movements per year).	6 years or after a rail break

c. *Torch cut.* Rail shall not be flame cut in any manner. This includes cropping of the rail end, burning bolt holes, and trimming mismatched ends. Rail shall be cut using a rail saw or other appropriate cutting tool.

d. *Short rail.* Rail less than 13 feet in length shall not be installed in track.

7-3. Lightweight rail.

Lightweight rail is defined as rail weighing less than 90 pounds/yard. Research has shown that lightweight rail may not be suitable for use in track which is subjected to heavy wheel loads.

a. Rail weights of 70 pounds/yard or less should be replaced if that rail is to experience car loads of more than 50 tons (25,000 pounds axle loads).

b. Rail weighing 75 to 85 pounds/yard may be adequate depending upon support conditions. A structural evaluation and stress analysis is necessary to determine the adequacy of these rail weights. Rail not adequate to support the desired wheel loads should be replaced.

c. The existence of lightweight rail in Categories A and B track should be considered when planning major repair and/or rehabilitation projects.

CHAPTER 8

TURNOUTS

8-1. General.

Turnouts are designed to divert trains from one track to another. Good turnout maintenance is essential for the safe and efficient operation of trains.

Major components of a turnout are the switch, frog, and guard rails. Figure 8-1 shows a typical turnout with the various parts identified.

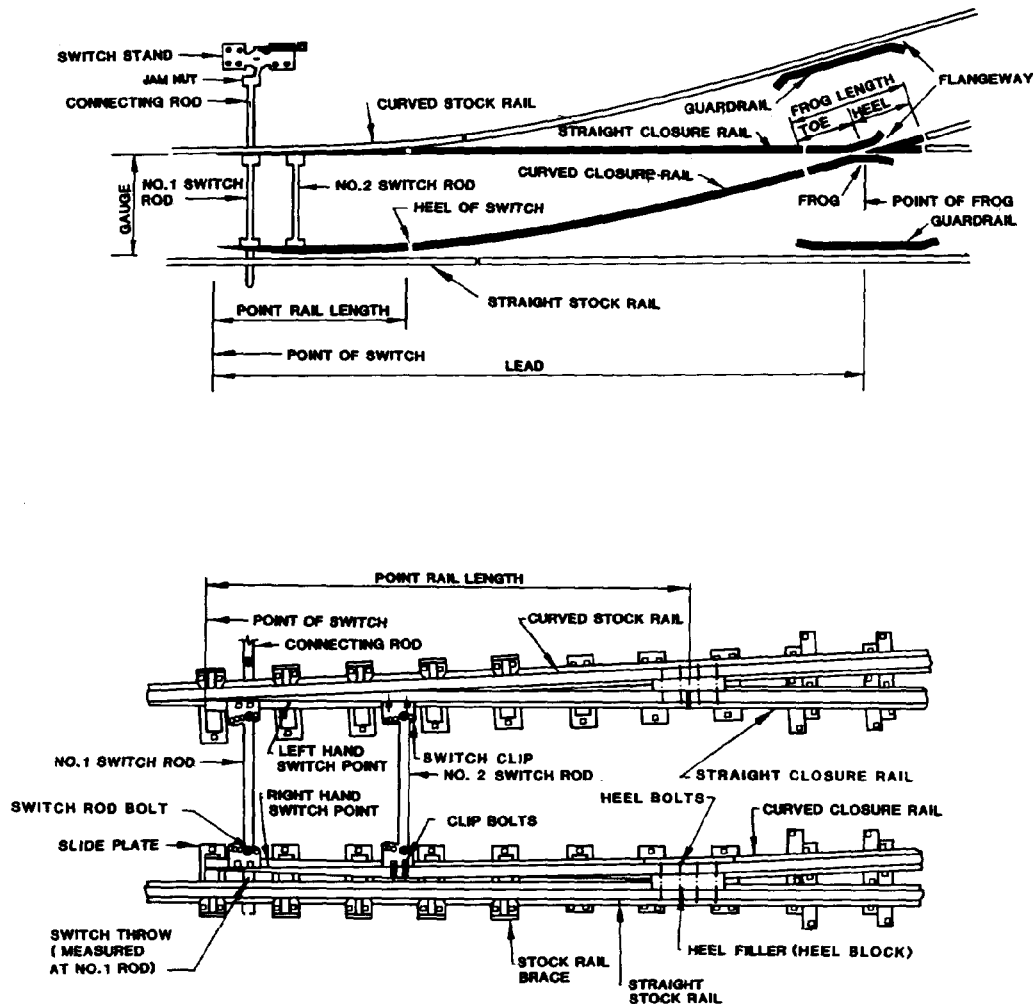

Figure 8-1. Parts of a turnout.

8-2. General requirements

a. Materials. All materials used within the limits of a turnout shall:

- (1) Be factory designed and constructed.
- (2) Be the proper type and size.
- (3) Be properly installed.
- (4) Not be flame cut or otherwise altered.

b. Rail. All rail used within the limits of a turnout shall be of the same weight and section. Compromise joints are not permitted within the limits of a turnout.

c. Ties. The standards in chapter 5 of this manual shall apply to ties within the limits of a turnout.

TM 5-628/AFR 91-44

d. Track geometry. Turnout track geometry shall conform with the standards in chapter 12 as well as those in this chapter.

e. Reversing tangent. It is recommended that the tangent between the frog and any reverse curve past the frog be no less than 50 feet in length as shown in figure 8-2.

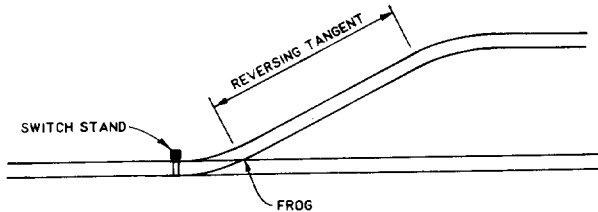

Figure 8-2. Reversing tangent length and switch stand placement.

f. Switch stand placement.

(1) The switch stand shall be installed so that when the switch is lined for the normal (main) route, the connecting rod keeps the points closed with a pulling (rather than a pushing) force. In most cases this will mean installing the stand on the diverging side of the turnout as shown in figure 8-2.

(2) When a ground-throw stand is used, the handle shall point toward the frog when the switch is lined for the normal (main) route.

g. Cleaning, lubrication, and adjustment. Switches and switch stands shall be cleaned, lubricated, and adjusted at least annually.

8-3. Switches and switch stands.

a. Switches shall be inspected for the following defects:

(1) Switch difficult to operate.

(2) Gap greater than $\frac{1}{8}$ (0.125) inch between the switch point and the stock rail. Checked with points in both positions. (See para 8-3b.)

(3) Worn or chipped switch points. (See para 8-3c and fig 8-3.)

(4) Point of switch higher than stock rail. (See para 8-3d(1) and fig 8-4.)

(5) Point rail beyond taper lower than stock rail. (See para 8-3d(2) and fig 8-4.)

(6) Damaged or missing switch stand lever latches or switch point lock. (see para 83e)

(7) Insecure, loose, damaged, or improperly installed switch stand. (See para 8-3f and 8-2g)

(8) Loose, damaged, or missing jam nut at the switch stand end of the connecting rod. (See para 8-3g(3))

(9) Bent, damaged, loose, binding, or improperly installed connecting rod, switch rods, or switch clips. (See para 8-3g)

(10) Loose, damaged, or missing switch clip, switch rod, or connecting rod bolts. (See para 83h)

(11) Loose, damaged, or missing heel bolts; cracked or improper heel joint bars or heel filler. (See para 8-3i)

(12) Loose, damaged, or missing rail braces. (See para 8-3j)

(13) Loose, damaged, or missing slide plates; dirt and debris buildup on slide plates.

(14) Missing cotter keys on switch rod and switch clip bolts.

(15) Debris in flangeways. (See para 8-3k)

(16) Debris obstructing switch rods and connecting rod. (See para 8-3g(1))

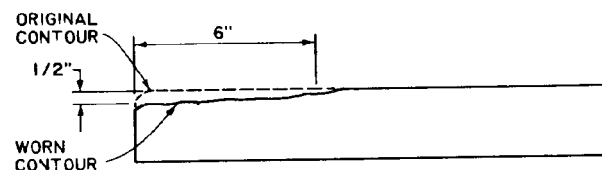

Figure 8-3. Switch point contour.

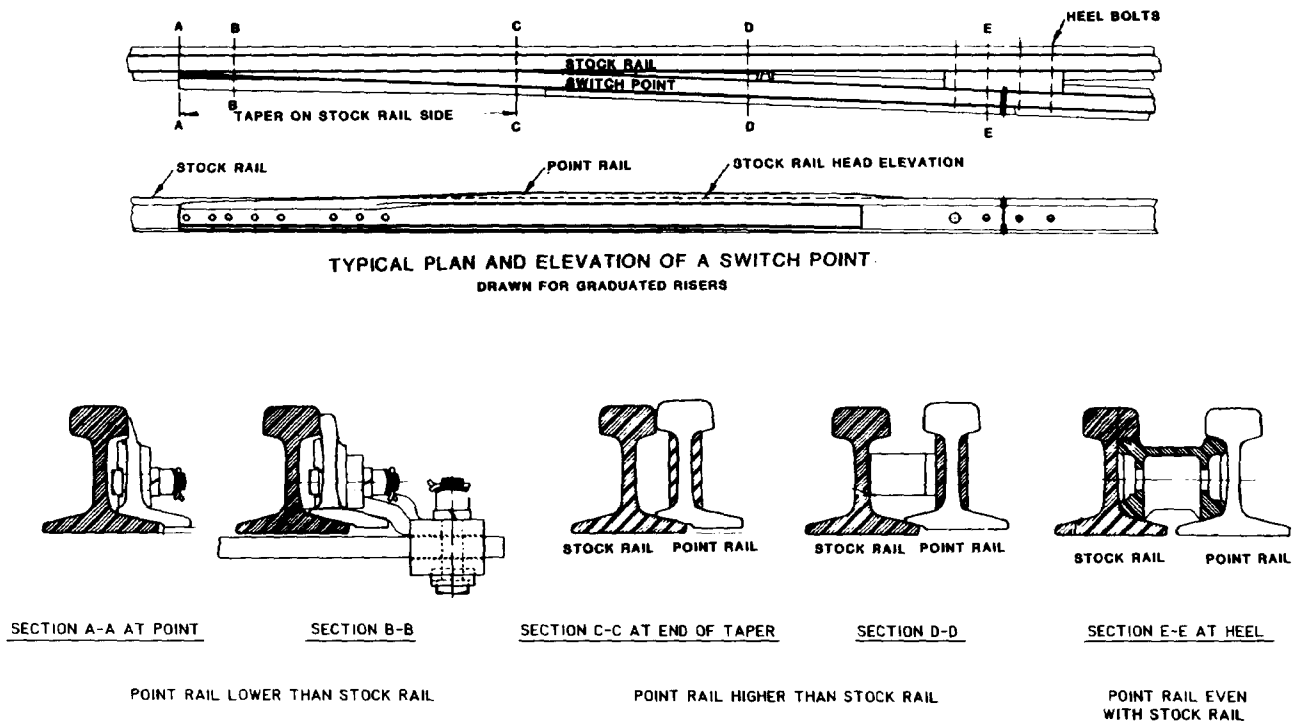

Figure 8-4. Switch point plan and elevation.

b. Switch point gap.

(1) If the switch can be thrown and locked in either direction with a $\frac{1}{8}$ (0.125) inch spacer between the switch point and the stock rail, operations through the turnout shall not exceed 10 mph.

(2) If the switch can be thrown and locked in either direction with a $\frac{1}{4}$ (0.25) inch spacer between the switch point and the stock rail, operations through that side of the turnout shall not be permitted.

c. Switch points. A switch point shall be restored or replaced if the point is chipped, broken, or worn more than $\frac{1}{2}$ (0.50) inch down and 6 inches back from the point. (See fig 8-3). Metal flow shall be removed to ensure proper closure. If a switch point is worn or damaged beyond these limits, operations through the turnout shall not exceed 10 mph.

d. Figure 8-4 shows the proper elevation of the switch point and point rail with respect to the stock rail.

(1) If the top surface of the switch point is higher than the top of the stock rail, operations through the turnout shall not exceed 5 mph.

(2) If the point rail beyond the taper is lower than the stock rail, operations through the turnout shall not be permitted.

e. Switch stand lever latches and point locks. Switch stand lever latches or switch point locks shall be installed on all switches. Where latches or locks are missing, damaged, insecure, or otherwise inoperative, operations through the turnout shall not exceed 10 mph.

f. Switch stand. The switch stand shall be fully secured to the headblock ties to prevent any unintentional movement of the switch points. Where operations through the switch result in visible lateral movement of the switch stand or opening of the switch points (point gap), operations through the turnout shall not be permitted.

g. Connecting rod, switch rods, and switch clips.

(1) These parts shall be installed and maintained to allow unobstructed motion when the switch is thrown. Rod ends and clips shall not contact adjacent ties. Damaged parts shall be replaced, and improperly installed parts shall be adjusted. Washers or similar spacers shall not be permitted between the switch clip and the switch point.

(2) If the connecting rod, switch rod, or switch clip is insecurely fastened or is damaged, operations through the turnout shall not be permitted.

(3) The jam nut at the switch stand end of the connecting rod shall be kept tight against the switch stand clevis.

TM 5-628/AFR 91-44

(4) Where washers or similar spacers are between the clip and switch point, operations through the turnout shall not exceed 10 mph.

h. Connecting rod bolts, switch rod bolts, and clip bolts. Connecting rod and switch rod bolts shall be installed with the nut on top and cotter keys in place. Clip bolts shall have cotter keys. All bolts shall be kept tight.

i. Switch heel (bolts, fillers, and joint bars). The heel of the switch shall be secure and the supporting switch ties solidly tamped. The inside joint bar (nearest and track center) should be a bent bar per AREA design. If any heel bolts are loose or missing, or the heel is otherwise not fully secure, operations through the turnout shall not exceed 5 mph.

j. Rail braces.

(1) Rail braces are essential to provide proper lateral support to the stock rails. Rail braces shall be fully secured to the tie and tight against the

outside of the stock rail on both sides of the turnout.

(2) It is recommended that rail braces be installed on each tie from the point of switch to within two ties of the switch heel.

(3) If there are less than four rail braces fully secured to the tie and tight against the outside of each stock rail, operations through the turnout shall not exceed 5 mph.

k. Debris in flangeways. Flangeways shall be kept clear of debris. Any obstructions, including ice and packed snow, shall be removed.

8-4. Frogs.

a. Frog point. A frog shall be restored or replaced if the point is chipped, broken, or worn more than $\frac{1}{2}$ (0.50) inch below the original top surface and 6 inches back from the original point location. (See fig 8-5)

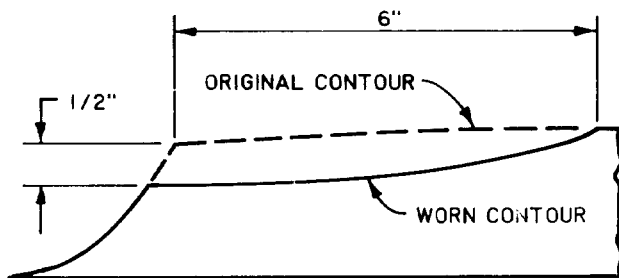

**DETAIL OF FROG
POINT ELEVATION**

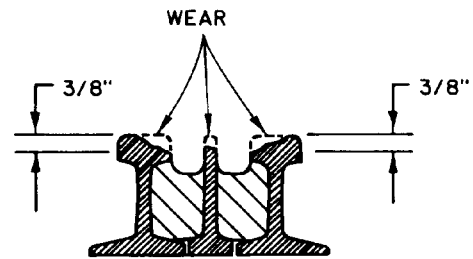

**SECTION THROUGH 1/2" POINT
SHOWING SURFACE WEAR**

Figure 8-5. Frog point and tread contours.

b. Frog surface. A frog shall be restored or replaced if the tread surface is worn more than $\frac{3}{8}$ (0.375) inch below its original contour. (See fig 8-5)

c. Guarding face of self-guarded frogs. The raised guarding face on a self-guarded frog shall not be worn more than $\frac{3}{8}$ (0.375) inch. (See fig 8-6)

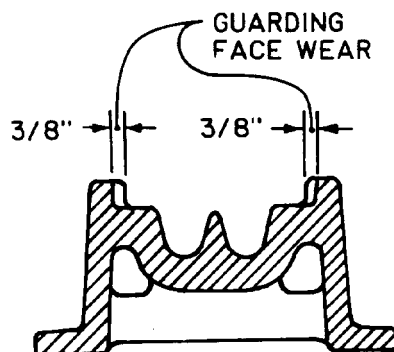

Figure 8-6. Allowable wear on guarding face of self-guarded frog.

d. *Repairing self guarded frogs.* If repairs are made to a self-guarded frog without removing it from service, the raised guarding face must be restored before rebuilding the point.

e. *Frog bolts.* All frog bolts shall be in place and tight.

f. *Flangeway width.* Standard frog flangeway width is $1\frac{7}{8}$ (1.875) inches. Where existing flangeway width is less than this amount, the restrictions in table 8-1 shall be applied. (See fig 8-7)

Table 8-1. Measurements and operating restrictions for frogs and guard rails

Parameter	Measurement			
	Standard (New or Fully Restored)	Operating Restrictions		
		10 mph	5 mph	No Operations
Frog flangeways:				
Width	1-7/8 in. (1.875 in.)	LT 1-5/8 in. (1.625 in.)	--	LT 1-1/2 in. (1.50 in.)
Depth	GE 1-7/8 in. (1.875 in.)	LT 1-1/2 in. (1.50 in.)	--	LT 1-3/8 in. (1.375 in.)
Guard check gage	54-5/8 in. (54.625 in.)	LT 54-1/4 in. (54.25 in.)	--	LT 54-1/8 in. (54.125 in.)
Guard face gage	52-3/4 in. (52.75 in.)	GT 53-1/8 in. (53.125 in.)	--	GT 53-1/4 in. (53.25 in.)
Guard rail flangeway:				
Width	1-7/8 in. (1.875 in.)	LT 1-5/8 in. (1.625 in.)	--	LT 1-1/2 in. (1.50 in.)

Note: GE = greater than or equal to, LT = less than, GT = greater than.

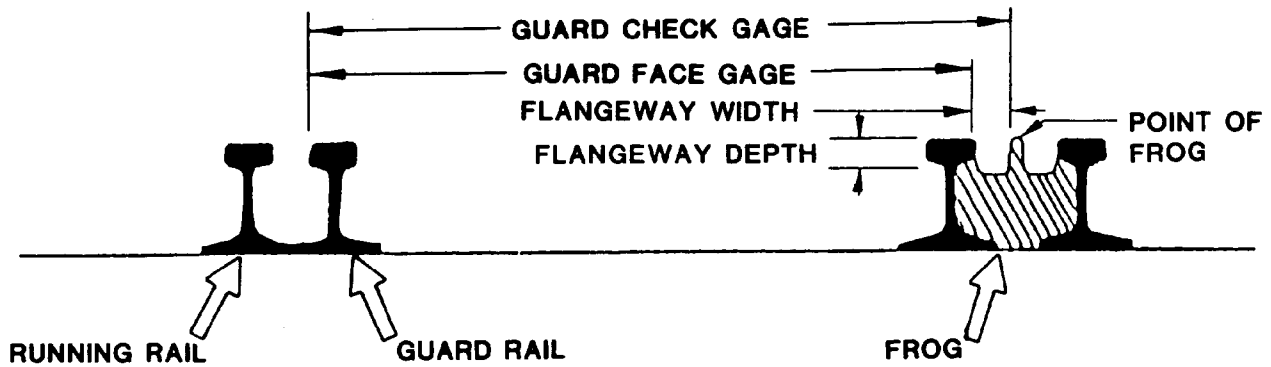
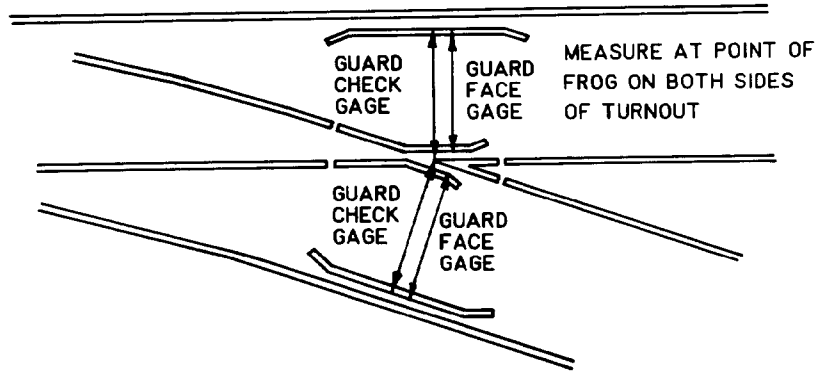

Figure 8-7. Measurement of flangeway width, flangeway depth, guard check gage, and guard face gage.

g. *Flangeway depth.* Standard frog flangeway depth is $1\frac{7}{8}$ (1.875) inches. Where existing flangeway depth is less than this amount, the restrictions in table 8-1 shall be applied. (See fig 8-7)

8-5. Guard rails.

a. Guard rails shall be in place, properly positioned, and fully secured.

b. Guard rails shall be installed so that the straight guarding face (the portion of the guard rail parallel with the running rail) extends in advance of the frog point a distance at least equal the values given in table 8-2.

c. *Guard check gage.* Standard guard check gage is 54% (54.625) inches. Where guard check gage measures less than this amount, the restrictions in table 8-1 shall be applied. (See fig 8-7)

Table 8-2. Minimum length of straight guarding face in advance of frog point

Frog Number	Length
4, 5, 6, 7, 8, 9, 10	14 in.
11, 12, 14	18 in.
15, 16	26 in.
18, 20	30 in.

d. *Guard face gage.* Standard guard face gage is $53\frac{3}{4}$ (52.75) inches. Where guard face gage measures more than this amount, the restrictions in table 8-1 shall be applied. (See fig 8-7)

e. *Flangeway width.* Standard guard rail flangeway width is $1\frac{7}{8}$ (1.875) inches. If the flangeway width is less than this amount, the restrictions in table 8-1 shall be applied. (See fig 8-7).

CHAPTER 9

RAIL CROSSINGS

9-1. General. Rail crossings are designed to carry one track across another at grade.

9-2. Requirements.

a. Size. Rail crossings shall be the proper size and section for the rails being joined.

b. Flangeway width. Standard flangeway width for rail crossings is $1\frac{7}{8}$ (1.875) inches. Where existing flangeway width is less than this amount, the following restrictions shall be applied.

(1) If the flangeway width is 1% (1.625) inches or less, operations through the crossing shall not exceed 10 mph.

(2) No operations shall be permitted through any crossing where the flangeway width is $1\frac{1}{2}$ (1.50) inches or less.

c. Flangeway depth. New or fully restored flangeway depth for rail crossings is at least $1\frac{7}{8}$ (1.875) inches. Where existing flangeway depth is less than this amount, the following restrictions shall be applied.

(1) If the flangeway depth is $1\frac{1}{2}$ (1.50) inches or less, operations through the crossing shall not exceed 10 mph.

(2) No operations shall be permitted through any crossing where the flangeway depth is 1% (1.375) inches or less.

d. Debris in flangeways. Flangeways shall be kept clear of debris. Any obstructions, including ice and packed snow, shall be removed.

e. Bolts. All crossing bolts shall be in place and tight. Loose bolts shall be tightened, and bolts which cannot be tightened shall be replaced. Missing bolts shall be replaced.

9-3. Anchors.

Where rail anchors are used on track approaching rail crossings, every third tie should be box anchored (four anchors per tie) for at least two rail lengths in all directions from the crossing.

CHAPTER 10

ROAD CROSSINGS

10-1. Drainage.

a. Adequate drainage is essential for satisfactory long-term performance of the track and road crossing.

b. Water shall not be allowed to pond on or near the track at a road crossing.

c. Catch-basins, gutters, ditches, subdrains, and culverts should be properly installed and kept free of debris.

10-2. Flangeways.

a. *Flangeway width.* For normal operations, flangeway width in a road crossing shall not be less than 2½ (2.50) inches nor greater than 3 (3.00) inches.

(1) If the flangeway width is less than 1¾ (1.75) inches, operations through the crossing shall not exceed 10 mph.

(2) No operations shall be permitted through any crossing where the flangeway width is 1½ (1.50) inches or less.

b. *Flangeway depth.* For normal operations, the flangeway depth in a road crossing shall not be less than 2 (2.00) inches.

(1) If the flangeway depth is less than 1½ (1.50) inches, operations through the crossing shall not exceed 10 mph.

(2) No operations shall be permitted through any crossing where the flangeway depth is 1% (1.375) inches or less.

c. *Debris.* Flangeways shall be kept clear of debris. Any obstructions, including ice and packed snow, shall be removed immediately.

10-3. Track.

a. *Ties, tie plates, and spikes.* When crossings are rebuilt, all ties within the crossing limits and for at least 20 feet beyond each end of the crossing shall be replaced, fully tie plated, and spiked with eight rail-holding spikes on each tie. (See fig 10-1) For road crossings carrying large volumes of traffic and/or heavy loads, the use of hardwood ties is recommended.

b. *Tie pads.* When crossings are rebuilt, it is recommended that rubber tie pads be installed between the tie and tie plate on all ties within the crossing area and for at least 20 feet beyond each end of the crossing.

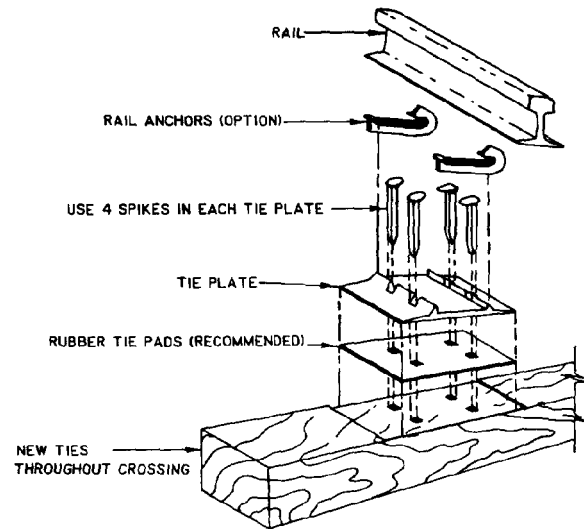

Figure 10-1. Track construction for road crossing.

c. *Joints.* Bolted rail joints are not desirable in road crossings. When crossings are rebuilt, it is recommended that all joints within the crossing and up to 20 feet outside the crossing be welded.

d. *Rail anchors.* Where the track on either side of the crossing is anchored, it is recommended that the anchoring pattern be continued through the crossing.

10-4. Crossing surfaces and materials.

a. It is essential that the crossing surface be maintained to provide a smooth crossing for vehicles and to prevent vehicle tires from striking the rails. The crossing surface shall be maintained at an elevation level with or slightly (not more than ¼ inch) above the top of the rails. Additionally, there shall be a smooth transition between the crossing surface and the adjoining pavement.

b. During routine track inspections the inspector should take note of the general condition of the crossing materials and report any damage or condition requiring repair or replacement. Any condition observed in a road crossing which would cause a hazard to motor vehicles using the crossing should be corrected immediately.

TM 5-628/AFR 91-44**10-5. Crossing protection.**

a. Signs and signals. During routine track inspections the inspector should observe the condition of all whistle posts, highway warning signs, and signals. Signs and signals should be easily legible and clearly visible.

(1) Signs and signals shall confirm to the requirements of the *Manual On Uniform Traffic Control Devices* (MUTCD), part VIII, "Traffic Control Systems for Railroad-Highway Grade Crossings".

b. Electric/electromechanical signals. Inspection and maintenance of electric and/or electromechanical signals should conform to manufacturer's recommendations, state/local requirements, and the minimum requirements given below.

(1) Inspection of electric/electromechanical signals shall be performed at the same frequency as track inspections (para 2-2.a.); however, inspections of signals shall be performed not less than once per quarter (at approximately 3-month intervals).

(2) Minimum inspection procedures for electric/electromechanical signals are as follows:

(a) Open case.

(b) Turn on signal with switch.

(c) Make sure signal is working properly and all bulbs are burning.

(d) Check to make sure lenses are clean. Clean lenses if needed.

(e) Check power source for obvious problems.

(f) Check charge on standby batteries.

(g) Note date, time condition (ok, existing problem, repaired, etc), and inspectors initials in a small note book that is to be kept in the signal case.

(3) At least once per quarter a detailed inspection of the signal shall be performed. The detailed inspection shall include all of the requirements of 10-5b(2) plus the following:

(a) Check all rail bonds.

(b) Check all connections.

(c) Measure and record voltages at critical locations (relays).

c. Any deficiency or defect in road crossing warning signs or signals shall be repaired immediately.

CHAPTER 11

BRIDGES

11-1. General.

- a.* Debris built up around piers or pilings in streams or drainage channels shall be removed.
- b.* All bridges shall be equipped with guardrails as specified in TM 5-627/AFM 91-33.
- c.* Rail anchors shall not be installed on track over open deck bridges. Any anchors found on track over an open deck bridge should be removed immediately.

11-2. Bridge inspection.

- a.* For Army track, at least one detailed inspection of each railroad bridge shall be made annually by a qualified bridge engineer in accordance with AR 420-72.
- b.* For Army track, a thorough inspection of the substructure and superstructure of each railroad bridge along with a load carrying capacity analysis

shall be made at least every 3 years in accordance with AR 420-72.

- c.* Army Technical Manual 5-626, "Bridge Inspection, Maintenance, and Repair," provides guidance for bridge inspections and determination of maintenance requirements.

- d.* Air Force. For railroad bridges on Air Force track, the BCE is responsible for determining when bridge inspections are required.

11-3. Dangerous conditions.

Any condition in a bridge or bridge foundation that might adversely effect train operations should be reported immediately to the proper authorities. Train operations over the structure shall not be permitted until the bridge is examined and known to be safe in accordance with TM 5-626.

CHAPTER 13

CLEARANCES

13-1. Measurement.

Vertical clearance shall be measured vertically from the top surface of the rail. Side clearance shall be measured horizontally from the centerline of the track.

13-2. Clearance requirements, tangent track.

Clearances for tangent track shall not be less than those listed in table 13-1 and shown in figure 13-1.

Table 13-1. Clearance Requirements for Tangent Track

<u>Obstruction</u>	<u>Required Clearance</u>
<u>Vertical Clearances</u>	
Overhead wires: open supply, arc wires, service drops	
0 to 750 volts	27 feet
750 to 15,000 volts	28 feet
Exceeding 15,000 volts.....	30 feet
Other overhead wires	27 feet
Building entrances (including engine-houses)	18 feet
Overhead bridges	22 feet
Other overhead obstructions	22 feet
<u>Side Clearances</u>	
Buildings	8 feet-6 inches
Buildings without platforms (delivery required)	8 feet
Platforms:	
Freight platforms up to 4 feet maximum height	6 feet-2 inches
Refrigerator car platforms up to 3 feet-3 inches high	6 feet-2 inches
Refrigerator car platforms 3 feet-3 inch to 4 feet high	8 feet
Low platforms (less than 8 inches high)	5 feet
Engine-house entrances	6 feet-6 inches
Building entrances (other than engine-houses)	8 feet
Canopies over platforms (canopy height 16 feet or less)	8 feet
Fences, retaining walls, utility poles, and other obstructions	8 feet-6 inches
Bridges	8 feet
Signs	8 feet
All loose, palliated, and stacked materials	8 feet
Parked vehicles	8 feet

Note: In curves side clearances shall be increased 1-1/2 (1.50) inches for each degree of curvature.

Table 13-1. Clearance requirements for tangent track.

TM 5-628/AFR 91-44

- 30' OVERHEAD WIRES (EXCEEDING 15,000 VOLTS)
- 28' OVERHEAD WIRES (750 TO 15,000 VOLTS)
- 27' OVERHEAD WIRES (INCL. 750 VOLTS OR LESS)

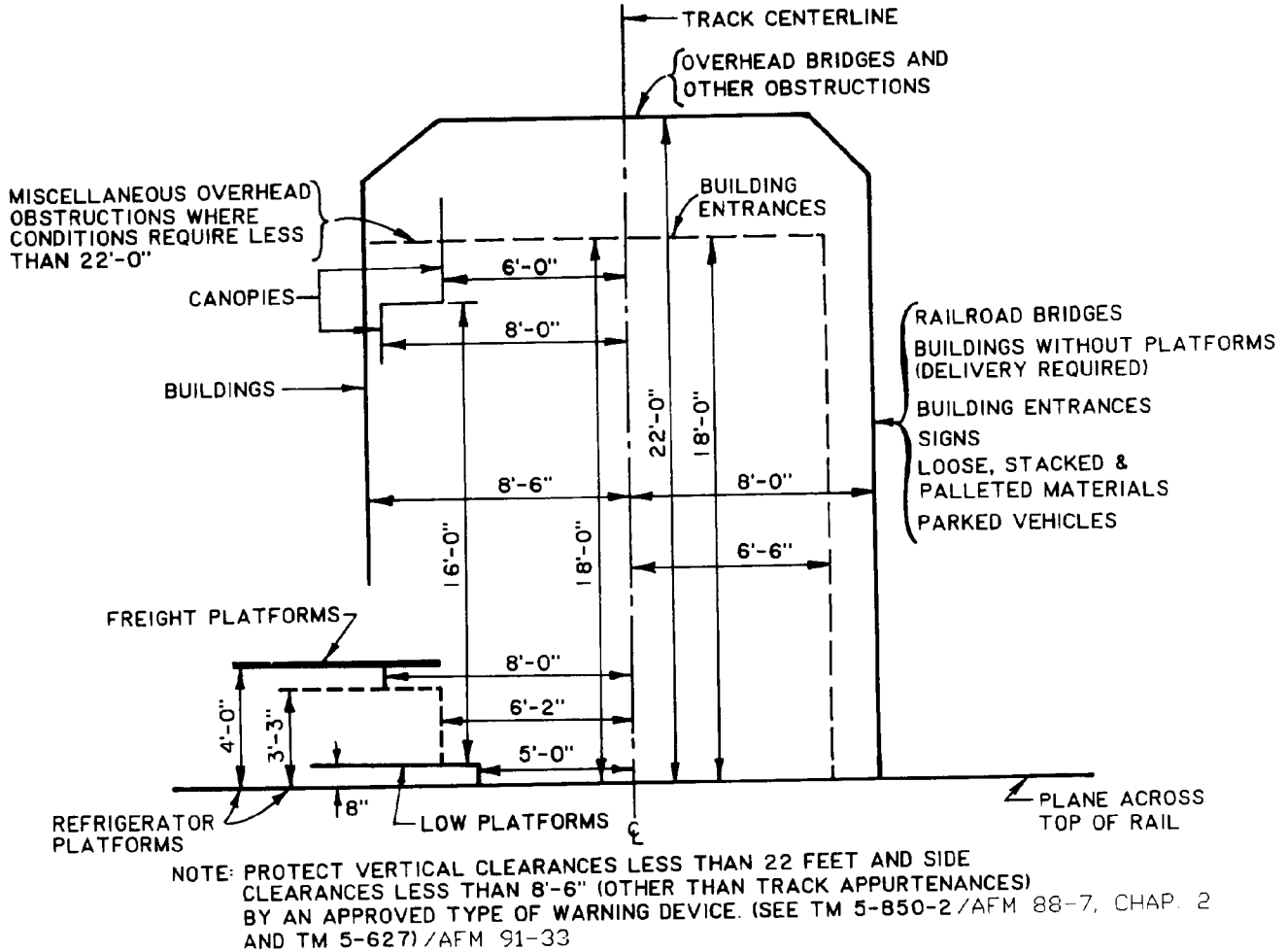

Figure 13-1. Minimum clearances for tangent track.

13-3 Clearance requirements, curved track.

a. For each degree of curvature, side clearances shall be increased 1½ (1.50) inches over that required in table 13-1 and figure 13-1.

b. When an obstruction is located adjacent to tangent track but the track is curved within 80 feet of the obstruction, the side clearances shall be increased by the following amounts:

Distance from Obstruction to Curved Track feet	Increase per Degree of Curvature inches
0-20	1½ (1.50)
21-40	1⅙ (1.125)
41-60	¾ (0.75)
61-80	⅜ (0.375)

13-4. Track centers.

The minimum spacing between the centerlines of adjacent tracks shall be maintained as follows:

<i>Type of Tracks</i>	<i>Minimum Center-to- Center Distance</i>
Yard, loading, and storage tracks.....	13 feet
Yard track parallel to a main or running track.....	15 feet
Passing track	15 feet

13-5. Changes to clearances.

Whenever changes in alinement or elevation are made, clearances shall be checked for compliance with the criteria given in this chapter. This is especially important in the vicinity of buildings, bridges, overhead structures, platforms, and tunnels.

CHAPTER 14

MISCELLANEOUS TRACK APPLIANCES

14-1 Track scales.

The inspection, maintenance, and calibration of railroad of railroad track scales are covered in the Association of American Railroads "Scale Handbook" which is published annually as a part of the *AREA Manual For Railway Engineering*. Track scales should be inspected and calibrated periodically in accordance with the recommendations given in the "Scale Handbook."

14-2. Bonded and grounded track.

a. Certain tracks used for the loading/unloading of fuels and ordinance are required to be bonded and grounded (TM 5-850-2/AFM 88-7, Chap. 2). During maintenance of bounded and grounded track care shall be taken to maintain the integrity of the rail bonds, ground rods, and connections.

b. During routine track inspections the general condition of the bonds, ground wires and connections shall be observed. Loose or missing bonds or connections shall be repaired immediately to meet the requirements of TM 5-850-2/AFM 88-7, Chap. 2. The occurrence of excessive corrosion in the terminal areas of the bond wires and ground wires indicates a need for cleaning, repair, or replacement. Bonds and grounds shall be replaced if there exist a large difference in electrical potential between the rails.

14-3. Derails.

a. Derails shall be maintained in good condition.

b. Derails shall be kept clean and painted in order to be readily visible to operating personnel.

CHAPTER 15

TRACK MAPS

15-1. General.

Track maps are essential in identifying and locating the components of the track network. Installations shall maintain a complete, accurate, and up-to-date set of track maps for use by maintenance and engineering personnel. Track charts as described in TM 5-627/AFM 91-33 may be used to supplement track maps, if desired.

15-2. Criteria.

a. Scale. Track maps should be drawn to a legible scale. The scale should be shown on each page of the map.

b. Title. Track maps should contain a standard title block.

c. Legend. Track maps should contain a legend identifying all symbols used in the track map.

d. Track data. Data presented on track maps should include:

- (1) All track, active and inactive.
- (2) Track name or identification for each track.
- (3) Track category for each track.
- (4) Buildings, loading docks, bridges, trestles, culverts, and other structures on or adjacent to the railroad roadway.
- (5) Highway and road crossings.
- (6) Connections to serving railroads.
- (7) Limits of Army track ownership and maintenance responsibility.
- (8) Installation property lines and railroad right-of-way lines.
- (9) Rail weight.
- (10) Turnout identification.
- (11) Degree of curvature for all curves.
- (12) Grades and profile information (optional).
- (13) Track stationing or mileposts (optional).

CHAPTER 16

MAINTENANCE ACTIVITIES FOR CATEGORY "C" TRACK

Section I. ARMY

16-1. General.

AR 210-17 requires a minimum level of maintenance for inactive (Category C) track. This section summarizes those requirements.

16-2. Maintenance requirements.

a. Maintenance of rail, ties, and ballast shall be discontinued.

b. Damaging vegetation in the ballast, roadbed, and ditches shall be controlled in accordance with section 3-3 of these standards.

c. Switches shall be kept properly adjusted and fully operational.

d. Bridges and other track structures shall be maintained in structurally sound condition with respect to their expected loading.

16-3. Inactivation and disposal.

In accordance with AR 420-72 and AR 405-90, action will be taken to dispose of track having no foreseeable need.

Section II. AIR FORCE

16-4. General.

This section summarizes Air Force requirements for a minimum level of maintenance for inactive (Category C) track.

16-5. Maintenance requirements.

a. Maintenance of rail, ties, and ballast shall be discontinued.

b. Damaging vegetation in the ballast, roadbed, and ditches shall be controlled in accordance with Chapter 3-3 of these standards.

c. Switches shall be kept properly adjusted and fully operational.

d. Bridges and other track structures shall be maintained in structurally sound condition with respect to their expected loading.

16-6. Disposal.

Action will be taken to dispose of track having no foreseeable need. Disposal of track and appurtenances shall be in accordance with AFR 87-4.

APPENDIX A

REFERENCES

A-1. Government Publications.

Departments of the Army, Navy, and Air Force

AR 210-17	Inactivation of Installations
AR 405-90	Disposal of Real Estate
AR 420-72	Pavements, Railroads, Bridges, and Associated Appurtenances
AR 420-76	Pest Management Program
AFR 87-4	Disposal of Real Property
AFR 91-21	Pest Management Program
TM 5-626	Bridge Inspection, Maintenance, and Repair
TM 5-627/MO-103/AFM 91-33	Maintenance of Trackage
TM 5-629/MO-314/AFM 91-19	Natural Resources-Weed Control and Plant Growth Regulation
TM 5-630	Natural Resources Land Management
TM 5-820-4/AFM 88-5, Chap. 4	Drainage for Areas Other Than Airfields
TM 5-850-2/AFM 88-7, Chap. 2	Railroad Design and Construction at Army and Air Force Installations
<i>Department of the Army, Corps of Engineers, Construction Engineering Research Laboratory, P0 Box 4005, Champaign, IL 61820-1305</i>	
Interim Report M-86/02	Preliminary Results of Army Rail Fatigue Failure Testing for Mobilization Planning.
<i>US Department of Transportation, Federal Highway Administration: Manual on Uniform Traffic Control Devices for Streets and Highways</i>	

A-2. Nongovernment Publications.

American Railway Engineering Association, 50 F Street, N.W., Washington, DC 20001.

American Wood-Preserver's Association, P0 Box 849, Stevensville, MD 21666

C6 Crossties and Switch Ties Preservative Treatment by Pressure Process

P2 Standard for Creosote and Creosote Solutions

P3 Standard for Creosote-Petroleum Oil Solution

APPENDIX B

FIELD IDENTIFICATION OF RAIL DEFECTS

B-1. Rail defects may be observed in track.

This appendix presents definitions relating to rail and brief descriptions of the common rail defects observed in track. Figure B-1 presents common rail nomenclature, and figure B-2 shows the relative positions of planes through the rail.

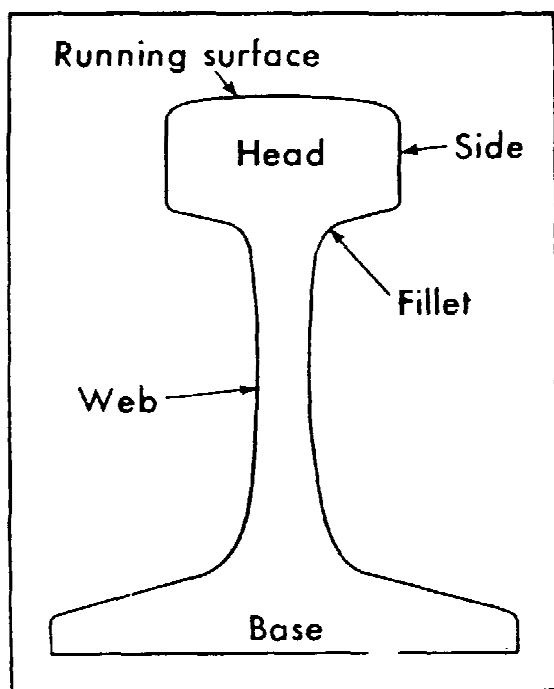

Figure B-1. Rail nomenclature.

B-2. Not all rail defects are critical.

A critical defect is a rail defect that will effect the safety of train operations. Noncritical defects are defects that occur in the rail but do not effect the structural integrity of the rail or the safety of the trains operating over the defect. Noncritical de-

fects are identified in the defect descriptions presented in this appendix. Table 7-1 of these standards presents a listing of rail defects, operating restrictions, and remedial actions.

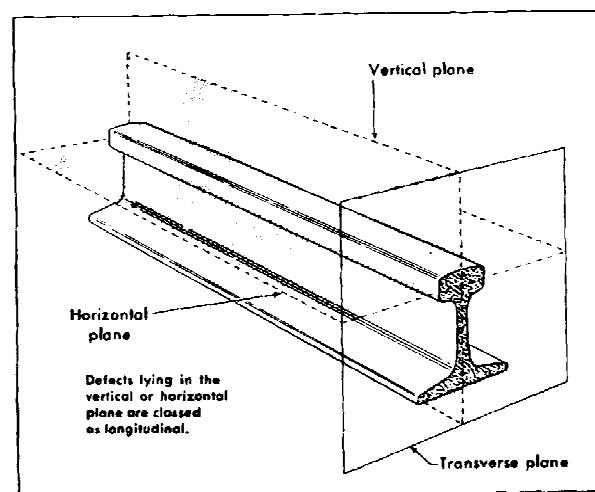

Figure B-2. Relative positions of planes through a rail.

B-3. Field identification of rail defects.

These descriptions are presented in alphabetical order to assist in identifying defective rails in track. Refer to TM 5-627/AFM 91-33 for additional information.

a. Bolt hole crack.

(1) *Description.* A progressive fracture originating at a bolt hole.

(2) *Appearance in track.* Bolt hole cracks are not visible until a bolt or a joint bar has been removed unless the defect has progressed beyond the bar. They may be recognized by a hairline crack extending from the bolt hole (fig B-3).

TM 5-628/AFR 91-44

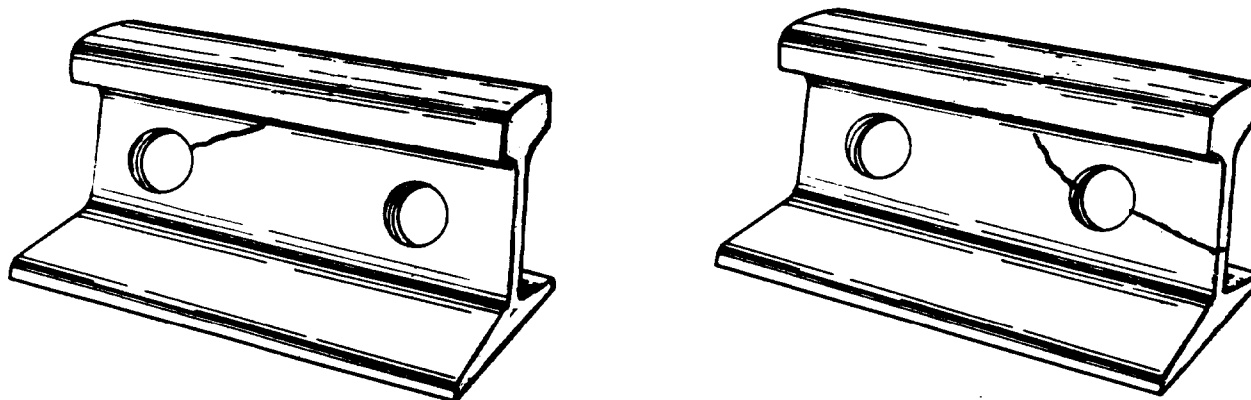

Figure B-3. General appearance of bolt hole cracks.

b. Broken base.

(1) Description. Any break in the base of the rail.

(2) Appearance in track. Generally appears as a half-moon crack break in the rail base. Figure B-4 illustrates three different appearances of broken bases.

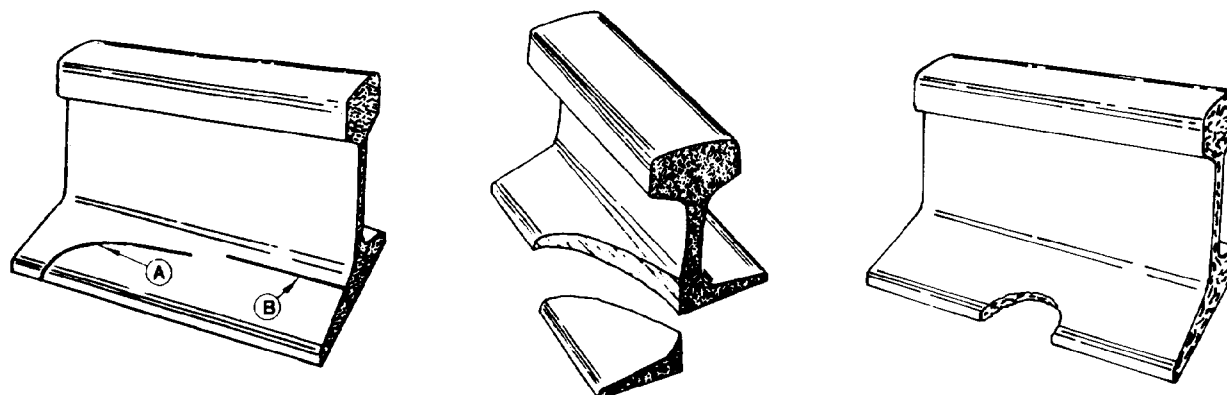

Figure B-4. General appearance of broken base.

c. *Complete break (broken rail).*

(1) *Description.* A complete transverse separation of the head, web, and base of the rail.

(2) *Appearance in track.* May appear as a hairline crack running completely around the rail, usually accompanied by bleeding or a separation of the rail at the break with one or both of the broken ends battered down (see fig B-5).

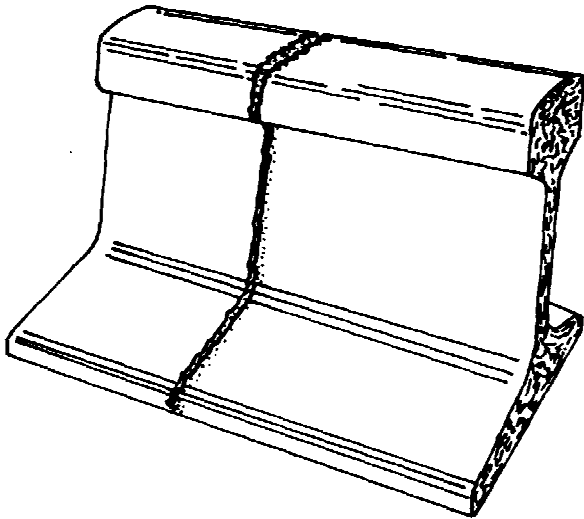

Figure B-5. General appearance of broken rail.

d. *Compound fissure.* See "transverse defects."

e. *Corrosion.*

(1) *Description.* The decaying or corroding of the metal in the web or base of the rail.

(2) *Appearance in track.* Pits or cavities in the upper base or the web of the rail. In advanced stages, a significant loss of material is evident.

f. *Corrugation.*

(1) *Description.* A repeated wavelike pattern on the running surface of the rail. Corrugations develop over a long period of time. A number of factors contribute to the development of corrugations with the actual cause dependent on the track and operating conditions. Corrugations are not a critical defect.

(2) *Appearance in track.* Small, hard, bright, short-pitch ridges along the running surface

of the rail varying anywhere from 2 to 18 inches apart and usually less than $\frac{1}{16}$ (0.0625) inch deep. Although the individual waves (ridges) are usually only a short distance apart, the corrugations may extend over a considerable distance (see fig B-6).

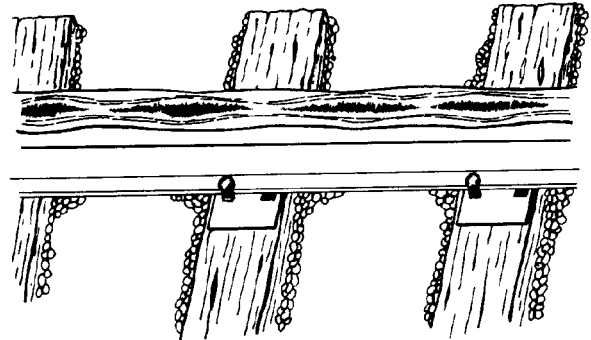

Figure B-6. General appearance of corrugation.

g. *Crushed head.*

(1) *Description.* The flattening of several inches of the rail head, usually accompanied by a crushing down of the metal but with no signs of cracking in the fillet under the head.

(2) *Appearance in track.* Generally appears as:

(a) Flattening and widening of the head for several inches with the entire head sagging.

(b) Small cracks in a depression on the running surface.

(c) In advanced stages, a bleeding crack may be present at the fillet under the head (fig B-7).

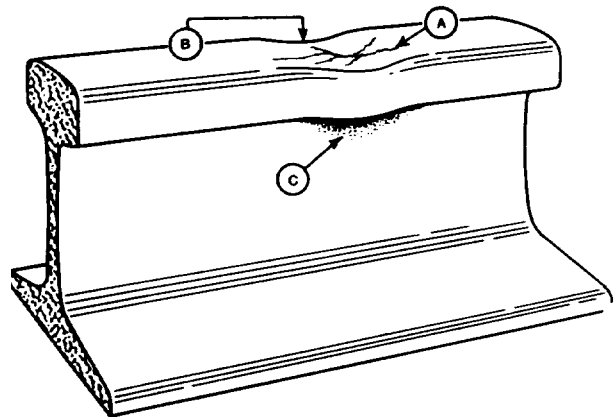

Figure B-7. General appearance of crushed head.

TM 5-628/AFR 91-44*h. Defective weld.*

(1) *Description.* A progressive transverse separation within an area where two rails have been joined by welding or a rupture at a weld where improper fusion has occurred.

(2) *Appearance in track.* No outward sign is visible until the separation reaches the rail surface. A defective weld may then be recognized by a vertical bleeding crack at the welded portion of the rail joint where the separation has reached the surface.

i. Detail fracture. See "transverse defects."*j. End batter.*

(1) *Description.* Damage caused by wheels striking the rail ends.

(2) *Appearance in track.* Appears as damage to or a depression in the top surface of the rail head at the ends of the rail (fig B-8).

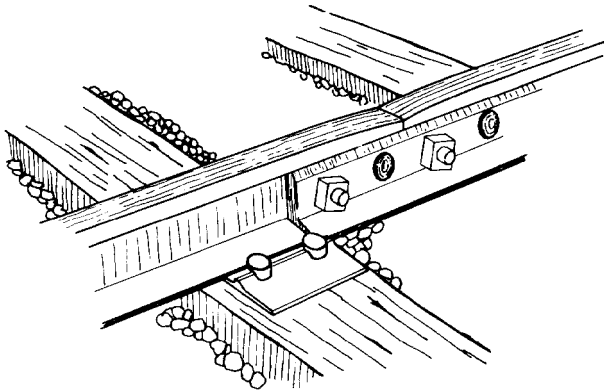

Figure B-8. Rail end batter.

k. Engine burns (burned rail).

(1) *Description.* Rail that has been scarred on the running surface by the friction of slipping locomotive wheels. An engine burn is not a critical defect; however, an engine burn may lead to an engine burn fracture.

(2) *Appearance in track.* Round or oval rough spots or holes on the tread of the running surface. Often the source of engine burn fractures. Engine burns may be deep (fig B-9).

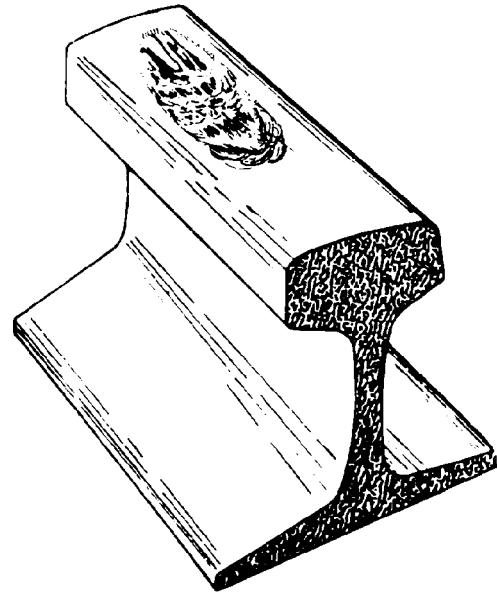

Figure B-9. Typical appearance of an engine burn.

l. Engine burn fracture.

(1) *Description.* A progressive fracture in the rail head starting from a point where engine wheels have slipped and burned the rail.

(2) *Appearance in track.* No sign of transverse separation is visible until the defect reaches the rail surface (cracks out). An engine burn fracture may then be recognized by one or more of the following characteristics.

(a) A hairline crack on the side of the head in the immediate vicinity of an engine burn and at right angles to the running surface. The crack may be visible on either the field or gage side of the head.

(b) Transverse thermal cracks extending from the burn to the gage corner and down the side of the head for at least $\frac{1}{8}$ (0.125) inch.

(c) A cracked out horizontal separation on the field side of the rail head under the burned area often accompanied by one or more thermal cracks extending transversely to the gage corner (fig B-10).

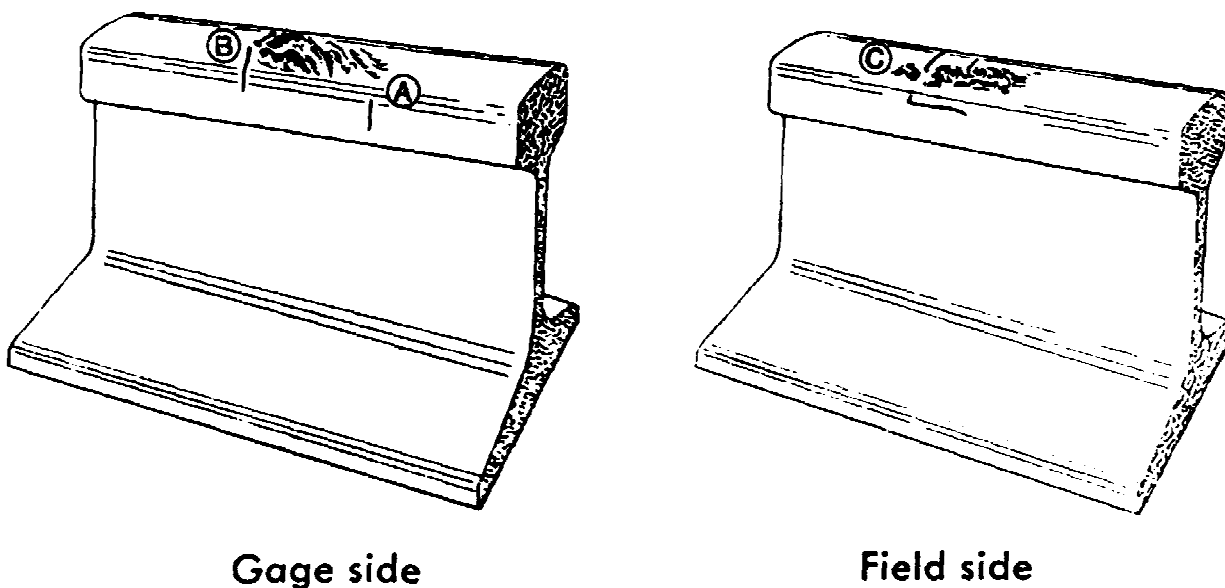

Figure B-10. General appearance of an engine burn fracture.

m. Flaking.

(1) *Description.* A progressive horizontal separation on the running surface near the gage corner often accompanied by scaling or chipping. Flaking should not be confused with shelling as flaking occurs only on the running surface near the gage corner and is not as deep as shelling. Flaking is not a critical defect.

(2) *Appearance in track.* Can be recognized by one or more of the following characteristics:

(a) Shallow depressions with irregular edges occurring on the running surface near the gage corner. Generally flaking will occur within $\frac{1}{4}$ (0.25) inch of the corner of the rail.

(b) Horizontal hairline cracks along the running surface near the gage corner of the rail head, resembling small slivers (fig B-11).

n. Flowed rail.

(1) *Description.* A rolling out of the tread metal beyond the field corner with no breaking down of the underside of the head. Flow is not a critical defect.

(2) *Appearance in track.*

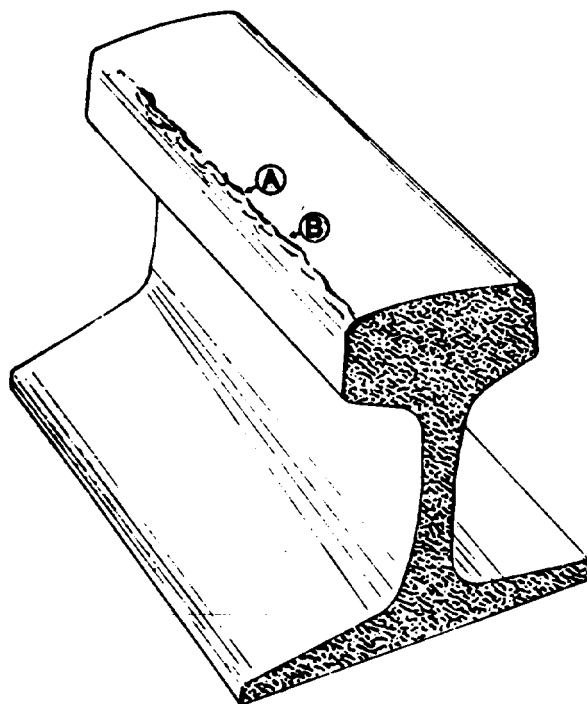

Figure B-11. General appearance of flaking.

TM 5-628/AFR 91-44

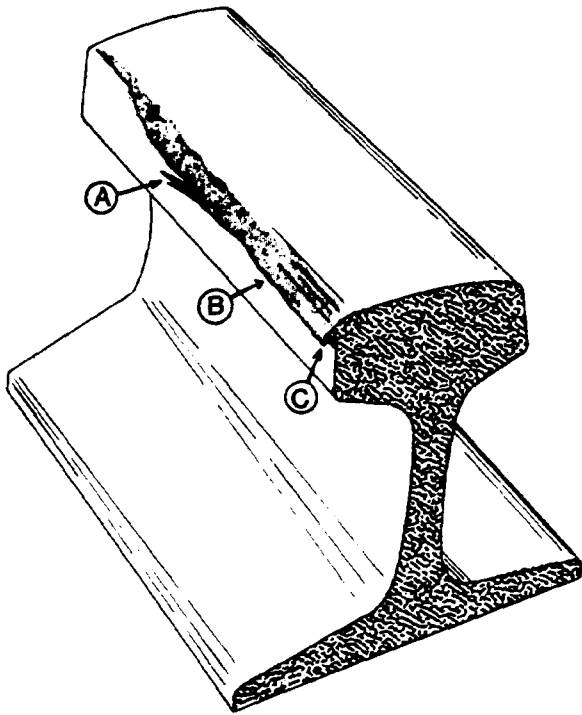

Figure B-12. General appearance of flow.

(a) Surface metal on the head flowed toward the field side giving a creased appearance on the running surface near the field corner.

(b) A protruding lip extending along the length of the rail.

(c) In the advanced stage, flow becomes bladelike, jagged, or nonuniform and may hang down or separate from the rail head (fig B-12).

o. Head/web separation.

(1) *Description.* A progressive fracture separating the head and web of the rail.

(2) *Appearance in track.* Can be recognized by one or more of the following characteristics.

(a) In earlier stages, wavy lines appearing along the fillet under the head.

(b) As the condition develops, a small crack will appear along the fillet on either side progressing longitudinally with slight irregular turns upward and downward.

(c) In advanced stages, bleeding cracks will extend downward from the longitudinal separation through the web and may extend through the base (fig B-13).

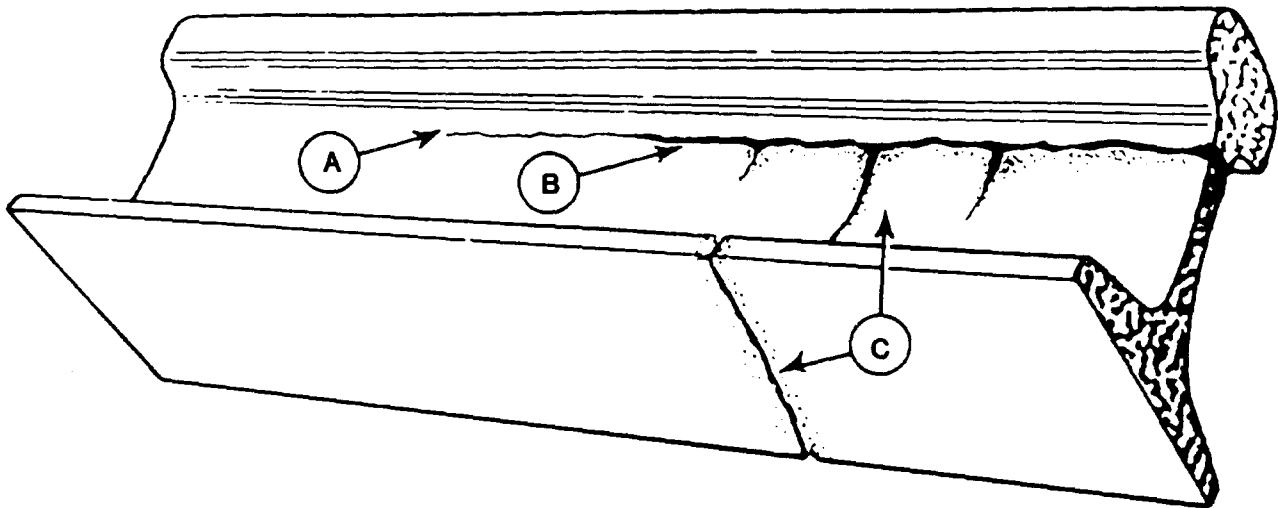

Figure B-13. General appearance of head/web separation.

p. Horizontal split head.

(1) *Description.* A progressive longitudinal fracture in the rail head parallel to the running surface.

(2) *Appearance in track.*

(a) Before cracking out, a moderate size horizontal split head will appear as a flat spot on the running surface often accompanied by a slight widening or dropping of the rail head. The flat spot will be visible as a dark spot on the bright running surface.

(b) After cracking out, the horizontal split head will appear as a hairline crack in either side or both sides of the rail head usually $\frac{1}{4}$ (0.25) inch or more below the top of the rail head (fig B-14).

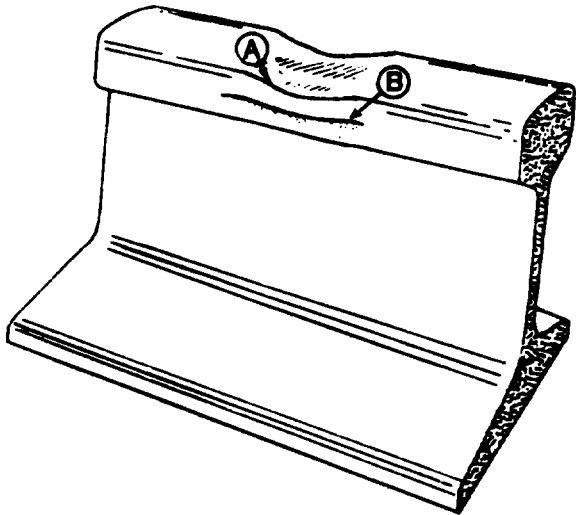

Figure B-14. General appearance of horizontal split head.

q. Mill defects.

(1) *Description.* Deformations, cavities, seams, or foreign material found in the head, web, or base of the rail. Mill defects are not critical defects.

(2) *Appearance in track.* Any deformation in the rail, broken out area, or inclusion (fig B15).

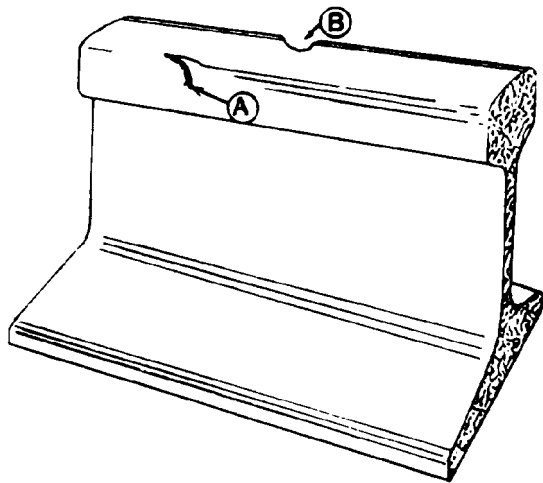

Figure B-15. General appearance of mill defects.

r. Piped rail.

(1) *Description.* A progressive longitudinal fracture in the web of the rail with a vertical separation or seam, forming a cavity in the advanced states of development.

(2) *Appearance in track.*

(a) A bulging of the web on either or both sides. Shallow cracks due to distortion may be found in the bulging surface.

(b) A slight sinking of the rail head may exist above the pipe (figs B-16 and B-17).

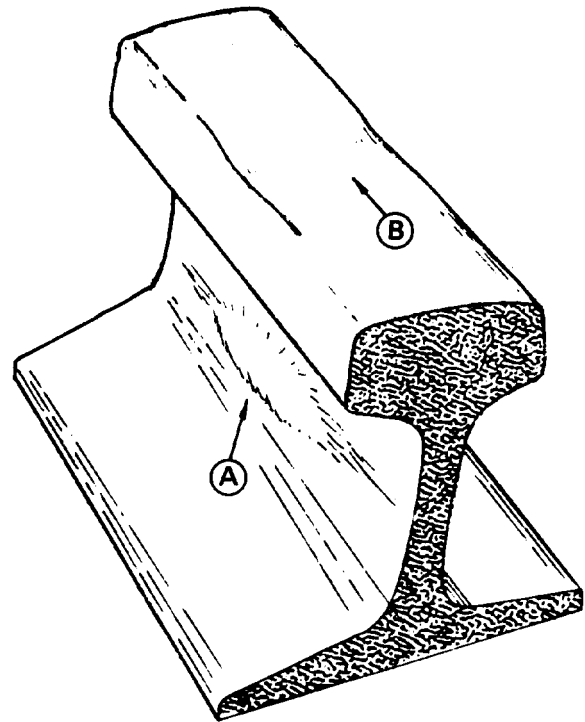

Figure B-16. General appearance of piped rail.

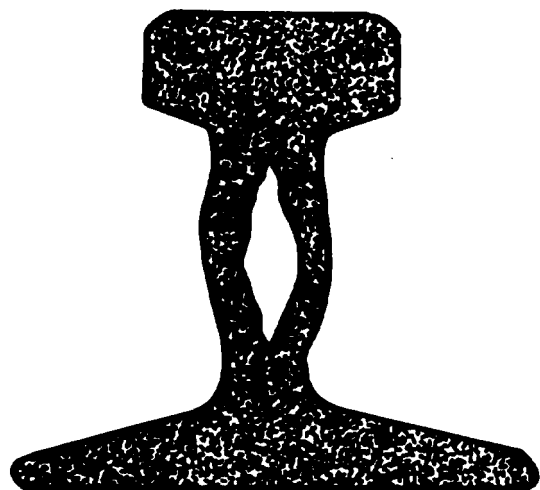

Figure B-17. Cross-sectional view of piped rail.

s. Rail wear.

(1) *Description.* The loss of material from the running surface and side of the rail head due to the passage of wheels over the rail.

TM 5-628/AFR 91-44

(2) *Appearance in track.* Rail wear appears as a rounding of the running surface of the rail head, particularly on the gage side (fig B-18).

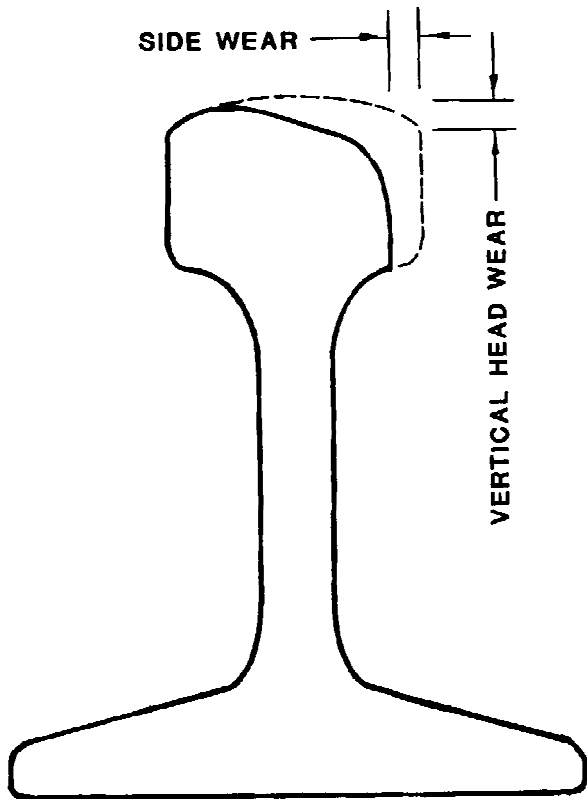

Figure B-18. General appearance of vertical head and side wear.

t. *Shelling.*

(1) *Description.* A progressive horizontal separation which may crack out at any level on the gage side but generally at the gage corner. It extends longitudinally not as a true horizontal or vertical crack, but at an angle related to the amount of rail wear. Shelling is not a critical defect.

(2) *Appearance in track.* Appears as one or more of the following:

(a) Dark spots irregularly spaced on the gage side of the running surface.

(b) Longitudinal separation at one or several levels in the upper gage corner with discoloration from bleeding.

(c) If the rail has been turned, the shelly spots will appear on the field side with an irregular overhanging lip of metal similar to flowed rail (fig B-19).

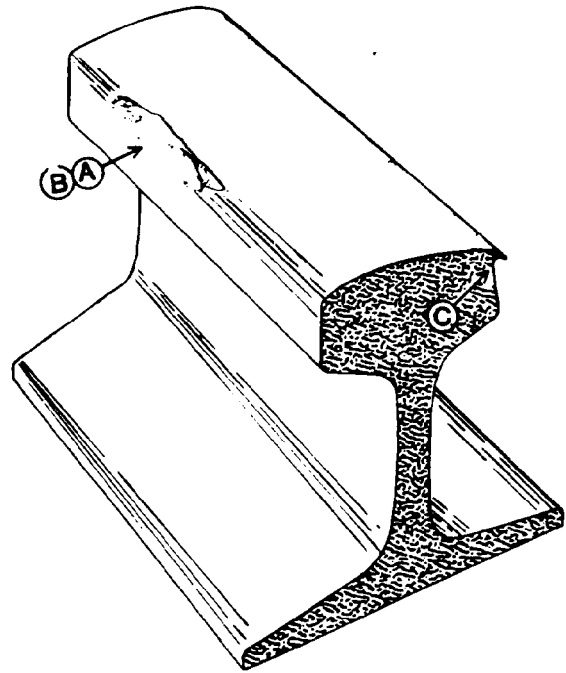

Figure B-19. General appearance of shelling.

u. *Slivers.*

(1) *Description.* A sliver is the separation of a thin, tapered mass of metal from the surface of the head, web, or base of a rail. Slivers are not critical defects.

(2) *Appearance in track.* Thin slivers on the surface of the rail head and parallel to the rail length similar to wood slivers (fig B-20).

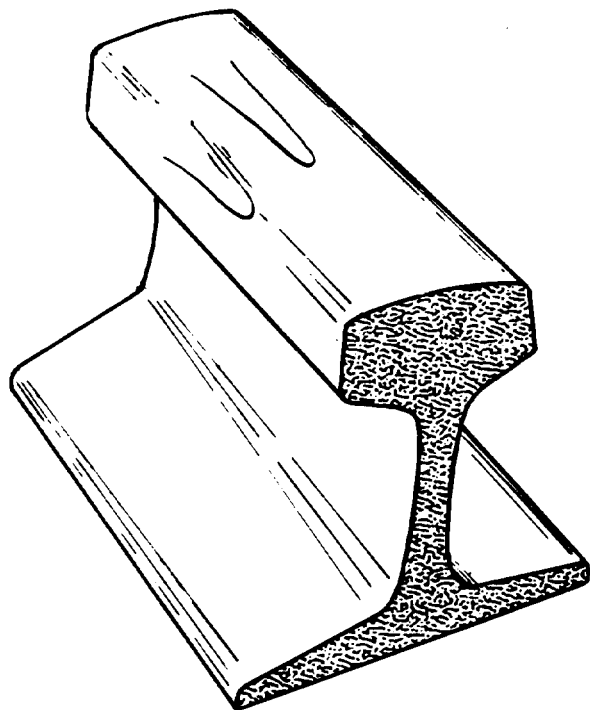

Figure B-20. General appearance of slivers.

v. *Split web.*

(1) *Description.* A progressive fracture through the web in a longitudinal or transverse direction, or both.

(2) *Appearance in track.* Horizontal and/or vertical bleeding cracks in the web (fig B-21).

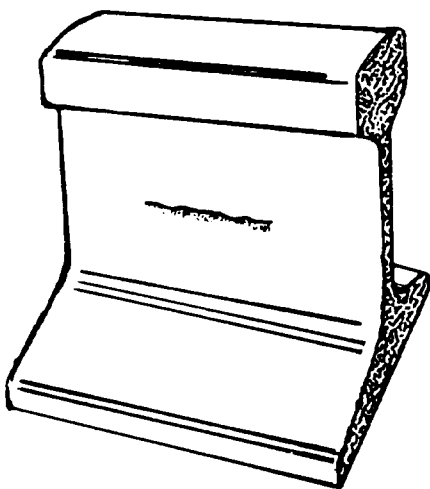

Figure B-21 General appearance of split web.

w. *Surface bent rail.*

(1) *Description.* The permanent downward bending of the rail ends due to long-term passage of traffic over track with loose or poorly supported

joints. Surface bent rail is not a critical defect and cannot be corrected without replacing the rail.

(2) *Appearance in track.* A downward bending of the rail head near the rail ends giving the appearance of low joints. When track with surface bent rail is surfaced (raised and tamped), the rail ends soon return to a lower elevation. In the more serious cases the vertical curve in the rail head is still visible after surfacing.

x. *Surface damage.*

(1) *Description.* Any damage to the surfaces of the rail, both the running surface and the external surfaces, caused by deep engine burns (running surface) or by striking the rail. Surface damage is not normally a critical defect but may lead to detail fractures or engine burn fractures.

(2) *Appearance in track.* Deep engine burns, dents, nicks, cuts, or other abnormalities on the surface of the rail.

y. *Torch cut rail.*

(1) *Description.* Any rail that is cut or otherwise modified (including bolt holes) using an acetylene torch or other open flame.

(2) *Appearance in track.* Irregular or rough rail ends and/or bolt holes (fig B-22).

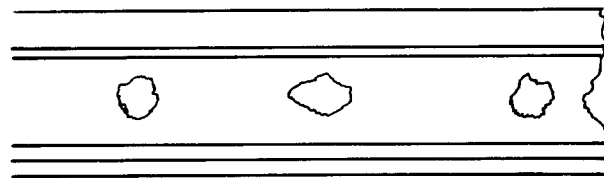

Figure B-22. General appearance of torch cut rail.

z. *Transverse defects.* (Compound fissure, transverse fissure, and detail fracture)

(1) *Description.* Any progressive fracture occurring in the rail head having a transverse separation, however slight. The exact type of transverse defect cannot be determined until after the rail is broken for examination.

(2) *Appearance in track.* Not visible until the defect reaches an outer surface. A transverse defect may be recognized by one or more of the following characteristics:

(a) A hairline crack on the side of the head at right angles to the running surface, at the fillet under the head, and occasionally on the running surface.

(b) Bleeding at the crack.

(c) A hairline crack at the gage corner of the rail head. On turned rail, this condition may occur at the field corner. Numerous small gage cracks or head checks are often present but should not cause suspicion unless a single crack extends

TM 5-628/AFR 91-44

much farther down the side and/or across the running surface.

(d) A horizontal hairline crack in the side of the rail head turning upward or downward at one or both ends usually accompanied by bleeding. Under such conditions a flat spot will generally be present on the running surface.

(e) A hairline crack extending downward at right angles from a horizontal crack caused by shelling of the upper gage corner of the rail head (fig B-23).

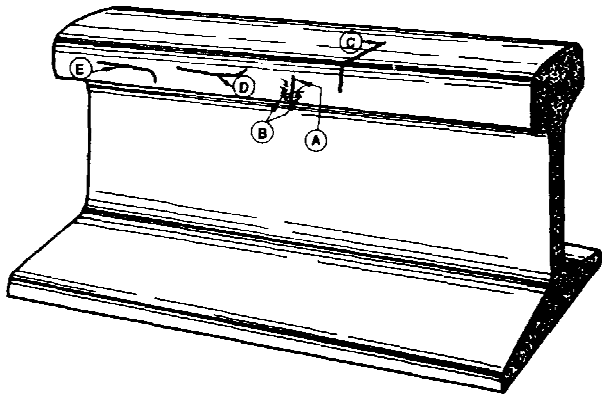

Figure B-23. General appearance of transverse defects.

aa. Vertical split head.

(1) *Description.* A progressive longitudinal fracture in the head of the rail perpendicular to the running surface.

(2) *Appearance in track.* Can be recognized by one or more of the following:

(a) A dark streak on the running surface.

(b) Widening of the head for the length of the split. The cracked side of the head may show signs of sagging.

(c) Sagging of the head causing a rust streak to appear on the fillet under the head.

(d) A hairline crack near the middle of the rail head.

(e) In advanced stages, a bleeding crack is apparent on the rail surface and in the fillet under the head (fig B-24).

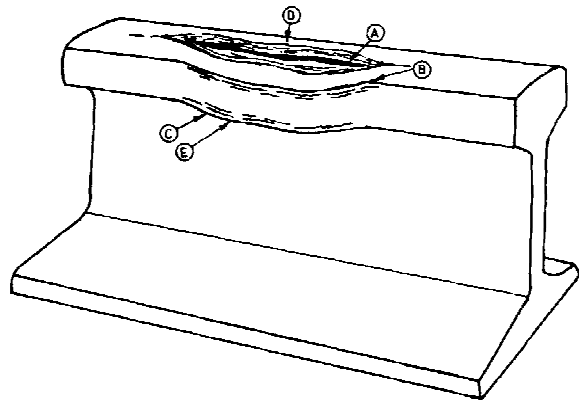
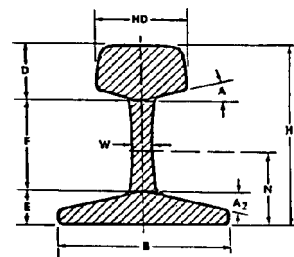

Figure B-24. General appearance of vertical split head.

APPENDIX C DETAILS OF RAIL SECTIONS

C-1.

Table C-1 of this appendix presents a listing of dimensions and properties for various rail sections. This table can be used with figure C-1 to assist in identifying rail sections and estimating amounts of rail wear.



(See Table D-1 For Key)

Figure C-1. Details of Rail Section.

Table C-1. Details of Rail Sections

Type	Weight per yard	Manufacturer's Brand						Rail Dimensions (Inches)									
		U.S. Steel Co. Old No.	U.S. Steel Co. New No.	U.S. Steel Co. Old No.	U.S. Steel Co. New No.	U.S. Steel Co. Old No.	U.S. Steel Co. New No.	Head (H)	Base (B)	Head (HD)	Web (W)	Depth of head (D)	Flange angle (F)	Depth of base (E)	Head angle (A)	Base angle (A ₁)	Cl. of bolts (N)
AREA	140*	140RE	...	7-5/16	6	3	3/4	2-1/16	4-1/16	1-3/16	3 to 1	4 to 1	4
AREA	136	136RE	...	7-5/16	6	3	2-15/16	11/16	4-3/16	1-3/16	4 to 2	4 to 1	3-3/4
AREA	133*	...	13331	133RE	...	7-1/16	6	3	11/16	1-15/16	3-15/16	1-3/16	3 to 1	4 to 1	3-3/4
AREA	132*	...	13225	132RE	...	7-1/8	6	3	21/32	1-3/4	4-3/16	1-3/16	4 to 1	4 to 1	3-7/8
AREA	131	...	13128	131RE	...	7-1/8	6	3	21/32	1-3/4	4-3/16	1-3/16	4 to 1	4 to 1	4-1/4
AREA	130	...	13025	130RE	...	6-3/4	6	2-15/16	21/32	1-27/32	3-11/16	1-7/32	4 to 1	4 to 1	3-3/8
AREA	119	119RE	...	6-13/16	5-1/2	2-21/32	5/8	1-7/8	3-13/16	1-1/8	4 to 1	4 to 1	3-1/4
AREA	115*	...	11525	115RE	...	6-5/8	5-1/2	2-23/32	5/8	1-11/16	3-13/16	1-1/8	4 to 1	4 to 1	3-1/4
AREA	112	...	11228	112RE	...	6-5/8	5-1/2	2-23/32	19/32	1-11/16	3-13/16	1-1/8	4 to 1	4 to 1	3-3/4
AREA	110	...	11025	110RE	...	6-1/4	5-1/2	2-25/32	19/32	1-23/32	3-13/32	1-1/8	4 to 1	4 to 1	3-1/8
AREA	100*	...	10025	100RE	...	6	5-3/8	2-11/16	9/16	1-21/32	3-9/32	1-1/16	4 to 1	4 to 1	2-31/32
ARA-A	100	10020	10020	565	163	100RA	10031	6	5-1/2	2-3/4	9/16	1-9/16	3-3/8	1-1/16	4 to 1	4 to 1	2-3/4
ARA-A	90	9020	9020	563	170	90RA	9031	5-5/8	5-1/8	2-9/16	9/16	1-15/32	3-5/32	1	4 to 1	4 to 1	2-37/64
ARA-A	80	8020	8020	561	169	...	8031	5-1/8	4-5/8	2-1/2	33/64	1-7/16	2-23/32	31/32	4 to 1	4 to 1	2-21/64
ARA-A	70	7020	7020	4-3/4	4-1/4	2-3/8	1/2	1-11/32	2-1/2	29/32	4 to 1	4 to 1	2-5/32
ARA-A	60	6020	6020	4-1/2	4	2-1/4	15/32	1-13/64	2-29/64	13/16	4 to 1	4 to 1	2-5/128
ARA-B	100	10030	10030	564	161	100RB	10032	5-41/64	5-9/64	2-31/32	9/16	1-45/64	2-55/64	1-5/64	13°	13°	2-65/128
ARA-B	90	9030	9030	561	162	90RB	9032	5-17/64	4-49/64	2-9/16	9/16	1-39/64	2-5/8	1-11/32	13°	13°	2-21/64
ARA-B	80	8030	8030	569	171	...	8032	4-15/16	4-7/16	2-7/16	35/64	1-15/32	2-15/32	1	13°	13°	2-15/64
ARA-B	70	7030	7030	4-35/64	4-3/64	2-3/8	33/64	1-23/64	2-17/64	59/64	13°	13°	2-7/128
ARA-B	60	6030	6030	4-3/16	3-11/16	2-1/8	31/64	1-1/4	2-11/64	7/8	13°	13°	1-29/32
ASCE	100	10001	10040	536	247	100AS	1000	5-3/4	5-3/4	2-3/4	9/16	1-45/64	3-5/64	31/32	13°	13°	2-65/128
ASCE	90	9002	9040	535	245	90AS	900	5-3/8	5-3/8	2-3/4	9/16	1-19/32	2-55/64	59/64	13°	13°	2-45/128
ASCF	85	8504	8540	531	235	85AS	850	5-3/16	5-3/16	2-9/16	9/16	1-35/64	2-3/4	57/64	13°	13°	2-17/64
ASCF	80	8004	8040	530	251	80AS	800	5	5	2-1/2	35/64	1-1/2	2-5/8	7/8	13°	13°	2-3/16
ASCF	75	7506	7540	529	214	75AS	750	4-13/16	4-13/16	2-15/32	17/32	1-27/64	2-35/64	27/32	13°	13°	2-15/128
ASCF	70	7010	7040	532	237	70AS	700	4-5/8	4-5/8	2-7/16	33/64	1-11/32	2-15/32	13/16	13°	13°	2-3/64
ASCF	65	6507	6540	534	236	65AS	650	4-7/16	4-7/16	2-13/32	1/2	1-9/32	2-3/8	25/32	13°	13°	1-31/32
ASCF	60	6015	6040	533	244	60AS	600	4-1/4	4-1/4	2-3/8	31/64	1-7/32	2-17/64	49/64	13°	13°	1-103/128
ASCF	55	5501	5540	537	130	55AS	550	4-1/16	4-1/16	2-1/4	15/32	1-11/64	2-11/64	23/32	13°	13°	1-103/128
ASCF	50	5005	5040	542	129	50AS	500	3-7/8	3-7/8	2-1/8	7/16	1-1/8	2-1/16	11/16	13°	13°	1-23/32
AT & SF	90	9021	9021	90SF	9033	5-5/8	5-3/16	2-9/16	9/16	1-15/32	3-5/32	1	4 to 1	4 to 1	2-37/64
Bang & Aroost	70	703	4-3/4	4-3/4	2-7/16	1/2	1-13/32	2-19/32	3/4	12°	12°	2-3/64
Can Nor	80	8010	8010	804	5	5	2-9/16	35/64	1-13/32	2-11/16	29/32	13°	13°	2-1/4
Can Pac	85	...	8524	85CP	856	5-1/8	5	2-1/2	9/16	1-7/16	2-11/16	1	4 to 1	4 to 1	2-11/32
Can Pac	65	6508	6508	654	4-31/64	4-3/8	2-1/4	15/32	1-9/32	2-11/32	35/64	4 to 1	4 to 1	2-1/32
C of NJ	135	6-1/2	6	3-5/32	3/4	2	3-9/32	1-7/32	14°	14°	2-55/64
C & A	70	7002	4-3/8	4	2-35/96	35/64	1-17/24	1-11/12	3/4	12°	12°	1-17/24

Notes: See Figure D-1 for key

All dimensions in inches

* Indicates rail recommended by AREA for new purchases due to current (1989) availability.

(Sheet 1 of 3)

Table C-1. Details of Rail Sections. (Sheet 1 of 3)

Table C-1. (Continued)

Type	Weight per Yard	Manufacturer's Brand										Rail Dimensions (Inches)						
		Ill. Steel Co. Old No.	Ill. Steel Co. Chicago Steel Co. T. & L. Co. U.S. Steel Corp.	Midvale Steel Co.	Northwestern Steel Co. Old No.	Northwestern Steel Co. New No.	Lackawanna Steel Co.	Columbia F. & I. Co.	Height (H)	Flare (F)	Head (HD)	Web (W)	Depth of Head (D)	Fishing Height (FH)	Depth of Foot (DF)	Head angle (A)	Base angle (A)	Cl. of Lashes (L)
C & NW	100	10035	10035			100OM	1006		5-45/64	5-9/64	2-9/16	9/16	1-39/64	2-61/64	1-9/64	13°	13°	2-79/128
C & NW	90		9035			90OM	904		5-17/32	5-3/32	2-1/2	1/2	1-17/32	2-31/32	1-1/32	13°	13°	2-23/64
C & NW	72	7201	7250		302	72NP			4-3/4	4-3/4	2-3/8	9/16	1-13/32	2-1/2	27/32	14°	14°	2-3/32
CB & Q	85	8506	8543	581	85-C	85CB	855	852	5-3/16	5-3/16	2-21/32	9/16	1-35/64	2-3/4	57/64	13°	13°	2-17/64
D & RG	90							906	5-1/2	5-1/8	2-9/16	9/16	1-5/8	2-7/8	1	14°	14°	2-7/16
D & RG	85							850	5-1/4	5-1/4	2-1/2	9/16	1-3/4	2-5/8	7/8	13°	13°	2-3/16
D & RG-C & S	85							853	5-3/8	4-7/8	2-1/2	9/16	1-15/32	2-29/32	1	4 to 1	4 to 1	2-29/64
DL & W	105				105-C	105DL	1052		6	5-3/8	2-3/4	5/8	1-23/32	3-1/4	1-1/32	13°	13°	2-21/32
DL & W	101		10133		299	101DL	10130		5-7/16	5-3/8	2-3/4	5/8	1-23/32	2-11/16	1-1/32	13°	13°	2-3/8
DL & W	91		9133		91-B		911		5-1/4	5-3/8	2-5/8	5/8	1-41/64	2-11/16	59/64	13°	13°	2-17/64
DL & W	75				75-C		753		4-11/16	5	2-1/2	1/2	1-43/64	2-13/64	13/16	18°	12°45'	1-17/128
Dudley	90						901		5-1/2	5	2-21/32	9/16	1-1/2	3-1/32	31/32	4 to 1	4 to 1	2-31/64
EJ & E	100		10050						5-9/16	5	2-21/32	9/16	1-37/64	2-51/64	1-3/16	4 to 1	4 to 1	2-75/128
Frictionless	125-1/2				125.5-F				7	5-1/2	1-13/16	11/16	2-3/8	3-13/32	1-7/32	18°	14°	2-3/4
Frictionless	98				305				5-27/32	5	2-1/2	9/16	1-31/32	2-25/32	1-3/32	18°	13°	2-31/64
Frictionless	97				97-B				5-7/8	5-9/64	2-1/4	9/16	1-15/16	2-55/64	1-5/64	13°	13°	2-65/128
Frictionless	93						932		6-1/8	5-1/2	2-1/8	19/32	1-13/16	3-3/8	15/16	13°	13°	2-5/8
Frictionless	92				304				5-7/16	5-3/8	1-15/16	5/8	2-3/32	2-5/16	1-1/32	13°	13°	2-3/16
Frictionless	90		9039						5-5/8	5-1/8	2-1/4	9/16	2	2-5/8	1	13°	13°	2-5/16
Frictionless	90		9029						6-3/32	5-1/8	1-59/64	9/16	1-15/16	3-5/32	1	4 to 1	4 to 1	2-37/64
Frictionless	79-1/2				79.5-C				5-3/16	5-3/16	1-15/16	9/16	2-1/32	2-9/32	7/8	13°	13°	2-1/64
Grt Nor	110		11036			110GN			6-1/2	5-1/2	2-3/4	19/32	1-5/8	3-3/4	1-1/8	1 to 4	1 to 4	3-1/4
Grt Nor	100		10036			100GN	1008		5-3/4	5	2-3/4	9/16	1-5/8	3	1-1/8	1 to 4	1 to 4	2-5/8
Grt Nor	90	9010	9024	560	160	90GN	9030	904	5-3/8	5	2-5/8	5/8	1-1/2	2-7/8	1	13°	13°	2-7/16
Grt Nor	90		9036						5-3/8	5	2-5/8	19/32	1-15/32	2-7/8	1-1/32	13°	13°	2-13/16
Grt Nor	85	8509	8553				854		5	5	2-21/32	21/32	1-19/32	2-1/2	29/32	14°	14°	2-5/32
Grt Nor	80	8009					802		5	5	2-13/32	5/8	1-5/8	2-1/2	7/8	14°	14°	2-1/8
Grt Nor	77-1/2	77501					775		5	5	2-3/8	5/8	1-11/16	2-1/2	13/16	14°	14°	2-1/16
Hock Val	80			540					5	4-59/64	2-31/64	29/64	1-85/128	2-25/64	111/128	13°	13°	2-1/16
Intergh	100	10005	10005		100-E	100RT	1005		5-3/4	5-3/4	2-7/8	9/16	1-45/64	3-5/64	31/32	13°	13°	2-65/128
Intergh	90		9050		90-E	90RT	902		5	5	2-7/8	11/16	1-25/32	2-11/32	7/8	13°	13°	2-3/64
Lehigh Val	136				136-C	136LV			7	6-1/2	2-15/16	21/32	1-7/8	3-7/8	1-1/4	4 to 1	4 to 1	3-1/16
Lehigh Val	110		11033		110-B	110LV			6	5-1/2	2-7/8	10/32	1-7/8	3-1/16	1-1/16	4 to 1	4 to 1	2-3/4
Mo Pac	85	8507	8550				853		5-7/32	5-1/4	2-15/32	75/128	1-3/4	2-39/64	55/64	13°	13°	2-21/128
Mo Pac	75	7512	7550	528	289	75MP	754		4-3/4	4-3/4	2-9/16	9/16	1-7/16	2-15/32	27/32	13°	13°	2-5/64
Nat Ry Mex	75								5	5	2-3/4	1/2	1-3/8	2-7/8	3/4	12°	12°	2-3/16
NYC	120						1201		7	6	3	21/32	1-5/8	4-5/16	1-1/16	4 to 1	4 to 1	3-7/32
NYC	105		10522		105-B	105DY	1051		6	5-1/2	3	5/8	1-13/32	31/32	4 to 1	4 to 1	3-1/8	
NYC	100	10003	10022		175		1001		6	5-1/2	3	19/32	1-5/8	3-13/32	31/32	4 to 1	4 to 1	2-5/8
NYC	95						951		5-1/32	5-1/2	3	5/8	1-9/16	2-15/32	1	4 to 1	4 to 1	2-15/64

(Continued)

(Sheet 2 of 3)

Table C-1. Details of Rail Sections. (Sheet 2 of 3).

Table C-1. (Concluded)

Type	Weight per yard	Manufacturer's Brand								Rail Dimensions (inches)								
		Ill. Steel Co. Div. No.	Ill. Steel Co. Carnegie Steel Co. Inland Steel Co. US Steel Corp.	NIPRA Steel Co.	Brickham Steel Co. Div. No.	Brickham Steel Co. New Arc.	Lackawanna Steel Co.	Columbian F. & I. Co.	Height (H)	Base (B)	Head (HD)	Web (W)	Depth of head (D)	Fishing height (F)	Depth of base (E)	Head angle (A)	Base angle (A')	C.L. of bolts (N)
NYC	80	8008	8022	543	220	80DY	801	5-1/8	5	5	2-21/32	17/32	1-1/2	1	4 to 1	4 to 1	2-5/8
NYC & St L	85	8521	8521	172	8531	5-3/8	4-7/8	2-17/32	17/32	1-29/64	2-15/16	63/64	4 to 1	4 to 1	2-29/64
NYNH & H	107	172-D	107NH	1072	6-1/8	5-1/2	2-3/4	19/32	1-23/32	3-11/32	1-1/16	13°	13°	2-47/64
NYNH & H	100	10004	10034	100	100NH	1002	6	5-1/2	2-3/4	19/32	1-23/32	3-11/32	1-1/16	13°	13°	2-39/64
Nor Pac	66	6602	6602	547	4-17/32	4-1/2	2-5/16	17/32	1-27/64	2-11/32	49/64	13°	13°	1-15/16
PS-Penn	130	13031	589	130-B	130PS	13030	6-5/8	5-1/2	3	11/16	2	3-13/32	1-7/32	18°	14°	2-3/4
PS-Penn	125	12531	584	308	125PS	12530	6-1/2	5-1/2	3	21/32	1-7/8	3-13/32	1-7/32	18°	14°	2-59/64
PS-Penn	100	10031	10031	538	96-A	100PS	10030	5-11/16	5	2-43/64	9/16	1-13/16	2-25/32	1-3/32	15°	13°	2-31/64
PS-Penn	85	8530	8531	559	67-A	85PS	8530	5-1/8	4-5/8	2-1/2	17/32	1-21/32	2-15/32	1	15°	13°	2-15/64
PRR	85	8503	8533	500	67	85PG	852	5	5	2-9/16	17/32	1-3/4	2-3/8	7/8	13°	13°	2-1/16
PRR	70	7005	7033	504	70PR	4-1/2	4-1/2	2-7/16	1/2	1-19/32	2-1/8	25/32	13°	13°	1-27/32
P & R	100	10032	165	100RG	1007	5-5/8	5-3/8	2-21/32	9/16	1-45/64	2-55/64	1-1/16	13°	13°	2-63/128
RG So	52	521	4	2-1/8	25/64	1-23/64	2	41/64	13°	13°	1-41/64
Russian	67-1/2	587	5-3/64	4-21/64	2-23/64	15/32	1-29/64	2-11/16	29/32	1 to 3	1 to 3	2-1/4
Sea A. Ln	85	8522	261	851	5-1/4	5	2-11/16	17/32	1-5/8	2-3/4	7/8	14°	14°	2-1/4
Sea A. Ln	75	7522	221	5	5	2-9/16	1/2	1-3/8	2-3/4	7/8	14°	14°	2-1/4
Soo. Ln	85	8520	8520	5-3/8	4-7/8	2-1/2	9/16	1-15/32	2-29/32	1	14°02'11"	14°02'11"	2-29/64
UP	75	7513	7523	75-B	901	5-3/4	5-3/8	2-3/4	17/32	1-1/2	3-3/8	7/8	13°	13°	2-9/16
UP	75	7524	7524	75SP	754	5	5	2-9/16	33/64	1-3/8	2-13/16	13/16	13°	13°	2-1/4
UP	75	757	4-15/16	4-7/16	2-7/16	33/64	1-3/8	2-5/8	15/16	4 to 1	4 to 1	2-1/4
Miscell	75	92	5	5	2-1/2	9/16	1-7/16	2-47/64	53/64	13°	13°	2-1/8
Miscell	70	97	703	4-3/4	4-3/4	2-7/16	1/2	1-13/32	2-19/32	3/4	12°	12°	2-3/64
Miscell	67	6704	6704	515	4-1/2	4-1/2	2-13/32	1/2	1-5/8	2-1/8	3/4	13°	13°	1-13/16
Miscell	67	6733	4-1/2	4-1/2	2-13/32	1/2	1-5/8	2-1/8	3/4	13°	13°	1-13/16
Miscell	65	6501	4-3/8	4-7/16	2-3/8	29/64	1-1/2	2-5/32	23/32	14°30'	12°30'	1-51/64
Miscell	65	6504	4-1/2	4-1/2	2-7/16	1/2	1-31/64	2-19/64	23/32	13°	13°	1-31/64
Miscell	60	6001	6051	4-1/4	4-1/16	2-5/16	1/2	1-7/16	2-1/8	11/16	14°	12°50'	1-1/8
Miscell	60	6017	6033	503	4-1/4	4-13/64	2-21/64	29/64	1-55/128	2-7/64	91/128	13°	13°	1-49/64
Miscell	56	5610	5610	4-1/4	3-31/32	2-7/32	13/32	1-7/16	2-1/8	11/16	14°	12°50'	1-13/16
Miscell	56	511	4	3-53/64	2-19/64	29/64	1-51/128	2-59/64	87/128	12°	12°	1-41/64
Miscell	56	5616	5633	4-1/4	4-1/8	2-1/4	3/8	1-27/64	2-1/8	45/64	13°	13°	1-49/64
Miscell	56	562	4-1/4	4-1/8	2-1/4	58/128	1-7/32	2-17/64	49/64	13°	13°	1-115/128

Notes: See Figure D-1 for key

All dimensions in inches

* Indicates rail recommended by AREA for new purchases due to current (1989) availability.

(Sheet 3 of 3)

Table C-1. Details of Rail Sections. (Sheet 3 of 3).

APPENDIX D
SUMMARY OF STANDARDS REQUIREMENTS, DEFECTS, AND
RESTRICTIONS

D-1.

Table D-1 of this appendix presents a summary of these standards requirements, defects, and operating restrictions.

Table D-1. Summary of Standards Requirements, Defects, and Restrictions

Item	Full Compliance		Restricted Operations			Paragraph Reference Standards
	Designated Value (New or Fully Restored)	Defective (No Restriction Required)	10 mph	5 mph	No Operation	
Roadway	--	Pumping track* Erosion* Slides or slippage* Slope instability* Settlement* Washouts*	--	--	--	3-1.
Drainage	--	Water diverted onto track* Hazardous drainage structures Inadequate drainage structures Obstruction of flow	Inferfere with track inspection	Inferfere with track inspection	--	3-2.
Vegetation	--	--	--	--	--	3.3.b.
Ballast	--	Fouled ballast Covers top of ties* 1 to 2	3	4	5 or more	4-3.
Ties - Consecutive defective	0	--	All joint ties defective	--	--	5.3.a.
Joint ties	--	--	Spacing exceeds 48"	--	--	5.3.b.
Missing/skewed	--	Improper type, broken, flame cut, or defective	--	--	--	5.3.d.
Tie plates	--	Improper type, broken, flame cut, or defective	--	--	--	6-1.
Spikes	--	Improper type, broken, flame cut, or defective Insufficient number* Improper installation Improper spiking pattern Through slots in angle bar Loose or missing spikes* Spike beneath rail base Improper type, flame cut, or defective	--	--	--	6-1. 6-3.a. 6-3.b. 6-3.c.(3) 6-3.d. 6-3.e. 6-4.a.
Joints bars	--	Improper design, or dimension, or home-made	--	--	--	6-4.b.
Compromise joints	--	--	One bar cracked or broken between center holes	Both bars cracked between center holes	Both bars broken, worn/loose, allow vertical movement of one rail with respect to other	6-4.c.
Joint bars - cracked or broken	--	--	--	--	--	6-4.c.
Bolts - loose or missing	None loose or missing	--	All bolts loose or only one bolt in each rail	--	All bolts in one rail are missing	6-4.e.
Rail end mismatch	0	--	GT 3/16"(0.1875")	--	GT 1/4"(0.25")	6-4.f.
Rail joint gap	--	--	GT 1.00"	--	GT 2.00"	6-4.g.
Rail - defective	--	See Table 7-1 in Chapter 7	--	--	--	7-1.
Turnouts - General	--	Improper materials	--	--	--	8-2.a.
	--	Rail not same weight and section	--	--	--	8-2.b.
	--	Compromise joint within turnout	1/8"(0.125)	--	1/4"(0.25")	8-2.b.
Switch point gap	0	--	Broken, worn GT 1/2"(0.50") down and 6" back	--	--	8-3.c.
Broken/worn points	--	--	--	--	--	8-3.c.
Point rail elevation	--	--	--	Point higher than stock rail	Point rail beyond taper lower than stock rail	8-3.d.
Lever latches or point locks	--	Missing, damaged, insecure, otherwise inoperative	--	--	--	8-3.e.
Switch stand	--	--	--	--	Lateral movement of under traffic or visible point gap due to movement	8-3.f.
Connecting rod, Switch rods, or Switch clips	--	Washers or spacers between clip and point rail	--	--	Irregularly fastened or damaged	8-3.g.
Switch heel	--	--	--	Heel bolts loose or missing, when not fully secure	--	8-3.i.
Rail Braces	--	--	--	Less than 4 fully secured tight braces on each stock rail	--	8-3.j.
Frog point wear/damage	0	1/2"(0.50)	LT 1.5/8"(1.625")	--	LT 1-1/2"(1.50")	8-4.a.
Frog surface wear	0	3/8"(0.375)	LT 1-1/2"(1.50")	--	LT 1-3/8"(1.375)	8-4.b.
Turnouts - Self-guarded frog guarding face wear	0	3/8"(0.375)	LT 54-1/4"(54.25")	--	LT 54-1/8"(54.125")	8-4.c.
Frog flangeway width	1-7/8"(1.875")	LT 1-3/4"(1.75")	GT 53-1/8"(53.125")	--	GT 53-1/4"(53.25")	8-4.c.
Frog flangeway depth	GE 1-7/8"(1.875")	--	LT 1.5/8"(1.625")	--	LT 1-1/2"(1.50")	8-4.f.
Guard check gage	54-5/8"(54.625")	--	LT 1-1/2"(1.50")	--	LT 1-3/8"(1.375)	8-4.g.
Guard face gage	52-3/4"(52.75")	--	LT 54-1/4"(54.25")	--	LT 54-1/8"(54.125")	8-4.g.
Guard rail flangeway width	1-7/8"(1.875")	LT 1-3/4"(1.75")	LT 1.5/8"(1.625")	--	LT 1-1/2"(1.50")	8-5.c.
Guard rail flangeway width	1-7/8"(1.875")	LT 1-3/4"(1.75")	LT 1.5/8"(1.625")	--	LT 1-1/2"(1.50")	8-5.c.
Rail crossing flangeway depth	GE 1-7/8"(1.875")	--	LT 1/2"(1.50")	--	LT 1-1/2"(1.50")	8-5.d.
Road crossing flangeway	2-1/2" to 3.0"	LT 2.0"	LT 1-3/4"(1.75")	--	LT 1-1/2"(1.50")	8-5.e.
Road crossing flangeway	GE 2.00"	LT 1-7/8"(1.875")	LT 1-1/2"(1.50")	--	LT 1-3/8"(1.375")	8-5.e.
Gage	56-1/2"(56.50")	--	GT 57-1/2"(57.50")	GT 57-3/4"(57.75")	LT 56.0" or GT 56.0"	12-2.d.
Crosslevel - tangent track	0	--	GT 1/1/2"(1.50")	GT 2-1/2"(2.50")	GE 3.00"	12-3.c.
Crosslevel - curved track	Designated super-elevation	--	GT 1-1/2"(1.50")	GT 2-1/2"(2.50")	GE 3.00"	12-3.c.
Warp	0	--	GT 2.00"	GT 4.00"	GE 3.00"	12-5.c.
Alignment - tangent track	0	--	GT 2.00"	GT 4.00"	GE 5.00"	12-5.c.
Alignment - curved track	Degree of curvature	--	GT 2.00"	GT 4.00"	GE 5.00"	12-6.c.
Profile	--	--	GT 2-1/2"(2.50")	GT 2-3/4"(2.75")	GE 3.00"	12-7.b.

NOTES: GT = Greater Than
 GE = Greater Than or Equal To
 LT = Less Than
 LE = Less Than or Equal To
 * Operating restriction may be needed depending on the seriousness of the condition.

The proponent agency of this publication is the Office of the Chief of Engineers, United States Army. Users are invited to send comments and suggested improvements on DA Form 2028 (Recommended changes to Publications and Blank Forms) to US Army Engineering and Housing Support Center (CEHSC-FB-P), Fort Belvoir, VA 22060.

By Order of the Secretaries of the Army and Air Force:

CARL E. VUONO
*General, United States Army
Chief of Staff*

Official:

PATRICIA P. HICKERSON
*Colonel, United States Army
The Adjutant General*

MERRILL A. McPEAK
General, USAF Chief of Staff

Official:

EDWARD A. PARDINI, *Colonel, USAF*
Director of Information Management

Distribution:

Army: To be distributed in accordance with DA Form 12-34E, Block 4380, requirements for TM 5-628
Air Force: F

REPRODUCTION AUTHORIZATION/RESTRICTIONS

This manual has been prepared by or for the Government and, except to the extent indicated below, is public property and not subject to copyright.

Copyrighted material included in the manual has been used with the knowledge and permission of the proprietors and is acknowledged as such at point of use. Anyone wishing to make further use of any copyrighted material, *by itself and apart from this text*, should seek necessary permission directly from the proprietors.

Reprints or republications of this manual should include a credit substantially as follows: Department of the Army, TM 5-628/AFR 91-44, Railroad Track Standards, *8 April 1991*.

If the reprint or republication included copyrighted material, the credit should also state: “Anyone wishing to make further use of copyrighted material, *by itself and apart from this text*, should seek necessary permission directly from the proprietors.”