

*TM 1-1500-204-23-8

TECHNICAL MANUAL

**AVIATION UNIT MAINTENANCE (AVUM)
AND AVIATION INTERMEDIATE
MAINTENANCE (AVIM) MANUAL**

FOR

GENERAL AIRCRAFT MAINTENANCE

(MACHINE AND WELDING SHOP PRACTICES)

VOLUME 8

*This manual together with TM 1-1500-204-23-1 through TM 1-1500-204-23-7, TM 1-1500-204-23-9 and TM 1-1500-204-23-10, dated 31 July 1992, supersedes TM 55-1500-204-25/1, dated 6 April 1970, including all changes.

DISTRIBUTION STATEMENT A: Approved for public release; distribution is unlimited.

HEADQUARTERS, DEPARTMENT OF THE ARMY

31 JULY 1992

CHANGE

NO. 1

**HEADQUARTERS
DEPARTMENT OF THE ARMY
Washington, D.C., 15 MARCH 2001**

AVIATION UNIT MAINTENANCE (AVUM)
AND
AVIATION INTERMEDIATE MAINTENANCE (AVIM) MANUAL
FOR
GENERAL AIRCRAFT MAINTENANCE
(MACHINE AND WELDING SHOP PRACTICES)
VOLUME 8

DISTRIBUTION STATEMENT A: Approved for public release; distribution is unlimited.

TM 1-1500-204-23-8, 31 July 1992, is changed as follows:

1. Remove and insert pages as indicated below. New or changed text material is indicated by a vertical bar in the margin. An illustration change is indicated by a miniature pointing hand.

Remove pages

i / (ii blank)

2-1 and 2-2

3-1 and 3-2

3-11 through 3-20

A-1 / (A-2 blank)

Insert pages

A / (B blank)

i / (ii blank)

2-1 and 2-2

3-1 and 3-2

3-11 through 3-20

A-1 / (A-2 blank)

TM 1-1500-204-23-8
C1

2. Retain this sheet in front of manual for reference purposes.

By Order of the Secretary of the Army:

Official:

ERIC K. SHINSEKI
General, United States Army
Chief of Staff

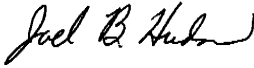
JOEL B. HUDSON
Administrative Assistant to the
Secretary of the Army
0032101

DISTRIBUTION:

To be distributed in accordance with Initial Distribution Number (IDN) 313302, requirements for TM 1-1500-204-23-8.

PRECAUTIONARY DATA

Personnel performing instructions involving operations, procedures, and practices which are included or implied in this technical manual shall observe the following instructions. Disregard of these warnings and precautionary information can cause serious injury, death, or an aborted mission.

WARNINGS, CAUTIONS, and NOTES are means of attracting attention to essential or critical information in a manual. Definitions are outlined as follows.

WARNING: An operating or maintenance procedure, practice, condition, statement, etc., which, if not correctly followed, could result in personnel injury or loss of life.

CAUTION: An operating or maintenance procedure, practice, conditions, statement, etc., which, if not strictly observed, could result in damage to or destruction of equipment or loss of mission effectiveness or long term health hazards to personnel.

NOTE: An essential operating or maintenance procedure, condition, or statement, etc., which must be highlighted.

WARNING

ELECTRICAL TESTS

Electrical power up to 500 volts is used in testing the equipment. Exercise extreme caution during these tests.

ELECTRICAL EQUIPMENT

All switches and electrical equipment shall be of the enclosed explosion-proof type. All metal apparatus shall be grounded to avoid the danger of igniting test fluid fumes or creating electrical shock.

LUBRICATING OIL

Lubricating oil, MIL-L-7808 or MIL-L-23699, contains an additive which is poisonous and absorbed readily through the skin. Do not allow oil to remain on skin any longer than necessary.

FUEL

When servicing aircraft or support equipment, clean up spilled fuel with cotton mops or cotton rags. Wash off any fuel on hands, body, or clothing.

HANDLING ACID

Wear protective clothing when mixing acid with water. Always pour acid into water, never water into acid.

HANDLING PYROTECHNIC FLARES

Handle pyrotechnic flares with the same care as high explosives.

MAGNESIUM ALLOY FIRE

Do not use water or any standard liquid or foam-type fire extinguishers on a magnesium alloy fire, because they may cause an explosion. Use dry sand or talcum powder, Federal Specification U-T-30.

REMOVING CORROSION

Take precautions to prevent possible dust explosions when removing corrosion from steel alloys. Use goggles or face shield when removing paint or corrosion with a wire brush or by the grinding method.

OXYGEN SYSTEM

Do not allow petroleum base products to come in contact with oxygen system components, as an explosion or fire may result.

Do not use masking tape to seal openings in oxygen regulators. Masking tape constitutes a safety hazard when used on either serviceable or repairable oxygen equipment.

Do not use drycleaning solvent, Federal Specification P-D-680, near oxygen storage or transfer systems; the combination of these two will form a highly explosive mixture.

GROUND SUPPORT EQUIPMENT

Do not attempt to lift any load when the hydraulic axle jack is tilted.

To prevent accidental falls, appropriate maintenance platforms/safety stands illustrated in appropriate workstand manuals or any other approved locally procured/manufactured safety stands/restraint equipment will be used when working (above 10 feet) on aircraft in a non-tactical environment.

Install safety lock when an adjustable-height maintenance platform is in use.

Ensure the air hose used with compressed air is safe for the pressure being handled.

Release air pressure in air compressor tank before performing maintenance on air compressors.

Disconnect power before changing belts on electrically-driven compressors.

Disconnect electrical power before opening or disassembling any part of electrical equipment.

FIRE EXTINGUISHERS

Halon type fire extinguishers, Monobromotrifluoromethane (CF₃Br) and Bromochloromethane (CB) are odorless gasses. When used in confined areas, available oxygen for breathing may be depleted. Use supplied breathing air when using these gasses in enclosed spaces.

COMPRESSED AIR

Compressed air shall not be used for cleaning purposes except if reduced to less than 30 psi and then only with effective chip-guarding and personal protective equipment.

TURBINE ENGINE OIL

To avoid contamination, do not use previously opened cans of engine oil. A new sealed can of fluid must be opened and used. When opening can, clean top and use a clean, sharp, unplated instrument to prevent contamination.

PROPER USE OF PLATED TOOLS

Use only chrome plated steel or unplated steel tools for disassembly or reassembly procedures described in this manual. Use of cadmium or zinc plated tools is not permitted since these platings are prone to chipping and flaking. Should these chips or flakes become embedded in aircraft parts galvanic corrosion will result. Should these chips or flakes enter fuel or oil wetted components they may eventually clog the filter or produce intergranular attack of nickel or titanium base alloys at elevated temperature. All tools regardless of type plating should be serviceable and free of chipping.

c/(d blank)

LIST OF EFFECTIVE PAGES

Insert latest changed pages; dispose of superseded pages in accordance with regulations.

NOTE: On a changed page, a vertical line, or other change symbol, in the outer margin of the page indicates the portion of the text affected by the latest change. Changes to illustrations are indicated by miniature pointing hands. Changes to wiring diagrams are indicated by shaded areas.

Dates of issue for original and changed pages are:

Original - 31 July 1992
Change 1 - 15 March 2001

Page No.	Change No.	Page No.	Change No.
Cover	0	3-19	0
a and b	0	3-20	1
c / (d blank)	0	3-21 / (3-22 blank)	0
A	1	A-1	1
(B blank)	0	(A-2 blank)	0
i	1	Glossary 1 and 2	0
ii	0	INDEX-1 through 6	0
1-1 / (1-2 blank)	0		
2-1 and 2-2	1		
2-3 through 2-11	0		
(2-12 blank)	0		
3-1	1		
3-2 through 3-11	0		
3-12 and 3-13	1		
3-14 and 3-15	0		
3-16 through 3-18	1		

TM-1-1500-204-23-8

TECHNICAL MANUAL

No. 1-1500-204-23-8

HEADQUARTERS
DEPARTMENT OF THE ARMY
Washington, D.C., 31 July 1992

Aviation Unit Maintenance (AVUM) and Aviation Intermediate Maintenance (AVIM) Manual
for
General Aircraft Maintenance Manual
(Machine and Welding Shop Practices)
Volume 8

REPORTING ERRORS AND RECOMMENDING IMPROVEMENTS

You can help improve this manual. If you find any mistakes or if you know of a way to improve the procedures, please let us know. Mail your letter or DA Form 2028 (Recommended Changes to Publications and Blank Forms) or DA Form 2028-2 located in the back of this manual directly to: Commander, US Army Aviation and Missile Command, ATTN: AMSAM-MMC-MA-NP, Redstone Arsenal, AL 35898-5230. You may also submit your recommended changes by E-Mail directly to ls-lp@redstone.army.mil or by fax (256) 842-6546/DSN 788-6546. A reply will be furnished directly to you. Instruction for sending an electronic 2028 may be found at the back of this manual immediately preceding the hard copy 2028.

DISTRIBUTION STATEMENT A: Approved for public release; distribution is unlimited.

TABLE OF CONTENTS

	<u>Page</u>
CHAPTER 1 INTRODUCTION	1-1
CHAPTER 2 MACHINE SHOP PRACTICES	2-1
CHAPTER 3 WELDING SHOP PRACTICES	3-1
APPENDIX A REFERENCES	A-1
GLOSSARY	Glossary 1
INDEX	Index 1

CHAPTER 1

INTRODUCTION

1-1. Purpose. This volume provides general information pertaining to machine and welding shop practices. The application of materials and techniques used on specific aircraft is not covered in this volume. Specific aircraft application, usage, and substitution are found in the individual aircraft maintenance manuals. This volume is of maximum benefit to the mechanic who desires information about machine and welding shop practices and procedures. This volume furnishes the mechanic a source of information about how to use and care for equipment in the machine and welding shops. This volume is not a requisitioning authority, and applicable repair parts and special tools list should be

consulted to obtain the unit of issue and National Stock Number of the items required for maintenance.

1-2. Scope. General information to guide aircraft maintenance personnel is covered within this volume; however, no attempt has been made to include special parts or equipment which are applicable only to individual or specific aircraft. General information on machine shop practices is contained in Chapter 2. Welding shop practices are contained in Chapter 3.

1-3. Consumable Materials. Refer to TM 1-1500-204-23-6 for consumable materials in this volume.

CHAPTER 2

MACHINE SHOP PRACTICES

2-1. General. The following paragraphs describe machine shop rules, machine safety precautions, care and use of equipment, laying out and mounting work, and special operations on drilling machines.

2-2. Shop Rules. The practices and procedures described in this chapter pertain to the manufacturing and repair functions of aviation activities and are applicable to all levels of maintenance. Because of the many types of Army aircraft, each shop within the manufacturing and repair section must, of necessity, have personnel trained in general practices and procedures to the extent that different type and model aircraft do not upset a smooth running shop.

a. Responsibility. All supervisory personnel are responsible for a continuing and effective shop safety program. To implement and maintain this program, shop supervisors will utilize bulletin boards, signs, and any other effective method. Shop personnel will cooperate in the shop safety program by making helpful recommendations, and continually exercising care and caution in the operation of all shop equipment. All shop personnel will strive to improve the safety program and be especially alert to observe and correct hazardous conditions and unsafe shop practices. All accidents, no matter how minor, shall be reported to the shop supervisor, and all published instructions regarding safety shall be strictly adhered to. Also, safety engineers and safety officers will ensure that proper safety procedures are adhered to in accordance with AR 385-10, Army Safety Program. The Occupational Safety and Health Act of 1971, OSHA 1910.251; all applicable fire codes, NFPA 410; and other accepted civilian and military safety practices.

b. Shop Housekeeping. Housekeeping is the yardstick by which the shops are judged. A clean, well-arranged shop is a safe shop and reflects credit on all personnel concerned with its operation. The following shop practices shall be observed:

(1) Oil pans or drip pans shall be used where leaking oil, grease, and similar materials may cause hazardous accumulations on equipment or floors. All spills shall be cleaned up immediately. Approved sweep-

ing compound may be used to remove these materials from the floor.

CAUTION

Floors shall not be cleaned with volatile or flammable liquids. Fire hazard which may damage equipment may result.

(2) Floors shall be maintained smooth and clean, free of all obstructions and slippery substances. Holes and irregularities in floors shall be repaired to maintain a level surface free from tripping hazards.

(3) All unnecessary materials on walls shall be removed and projections shall be kept to a minimum.

(4) Aisles shall be clearly defined and kept free of hazardous obstructions. Where possible, aisles shall be suitably marked by painting.

(5) All machines, work benches, aisles, etc., shall be adequately illuminated.

c. Equipment Safety. Unsafe equipment shall be reported immediately. The following equipment safety practices shall be observed:

(1) Machines shall be located to provide operators with sufficient space to handle materials and perform job operations without interference.

(2) Bolt down all machinery that can move or walk due to vibration (drill press, bench grinder, etc.).

(3) Substantial low resistance conductors shall be used to ground all stationary and portable machines, equipment, or other devices in which static charges may be generated, or which require electrical circuits of a hazardous nature.

(4) Shop machinery shall be operated only by qualified personnel observing safe practices.

TM 1-1500-204-23-8

(5) Safety devices, such as guards, interlocks, automatic releases, and stops, shall always be kept in operating condition.

(6) Ensure that all unauthorized personnel are clear of area before opening valves or energizing electrical circuits for starting machinery.

(7) Suitable mechanical guards, such as enclosures or barricades, shall be permanently installed on all machinery not already equipped with such to eliminate danger of injury from moving parts.

(8) Machinery shall not be adjusted, repaired, oiled, or cleaned while machine is in operation or power is on.

(9) Personnel operating machinery shall wear protective clothing as prescribed. A protective face shield or goggles shall be worn when operating a grinder regardless of whether grinder is equipped with attached shields.

(10) Jewelry shall not be worn while performing any maintenance.

d. Fire Safety. A constant vigilance must be maintained to seek out fire hazards. Fire hazards are constantly present in the shop where sparks, friction, or careless handling can cause an explosion that may destroy equipment or buildings, and injure or kill personnel. Refer to AR 385-10, The Army Safety Program and the Occupational Safety and Health Act of 1971. The following fire safety practices shall be observed:

(1) NO SMOKING signs shall be placed in areas where smoking could create a fire hazard.

(2) Personnel shall be trained in the use, knowledge, and location of shop fire fighting equipment.

(3) Each shop shall be equipped with fire extinguishers suited for type fire most likely to occur.

(4) Use correct fire extinguisher for class of fire as follows:

- Class A fire (wood, paper, trash, etc). Use water or soda-acid fire extinguisher.

- Class B fire (oil, paint, fuel, grease, etc). Use dry chemical or CO₂ if available.

- Class C fire (electrical equipment). Use dry chemical or CO₂ if available.

- Class D fire (combustible metals) magnesium, titanium, zirconium, sodium, lithium, and potassium. Use dry powder type fire extinguisher.

(5) Oily waste, rags, and similar combustible materials shall be discarded in self-closing metal containers which shall be emptied daily.

(6) Flammable materials shall not be stored in the shop.

(7) Use only approved cleaning solvents.

2-3. Machine Safety Precautions. The information in the following paragraphs does not give specific procedures for operation of various type machinery found in the machine shop, but does include safety measures and general practices involved in the use of machines. For information on operation and service of specific machinery, refer to the applicable operation and service instructions manual.

a. Drilling Machines. Use drilling machines for reaming, boring, facing, and similar operations. The following safety precautions shall be followed when using drilling machines:

- Clamp work securely so that work will not move.
- Do not permit spindle (rotating shaft with chuck attached) to feed beyond its limit of travel when drilling.
- Use a bit with the flute ground slightly flat when drilling brass or bronze.
- Stop machine prior to attempting to adjust work that has become jammed.

b. Grinding Machines. Use grinding machines for sharpening tools, dressing metal, and other functions requiring removal of small amounts of metal. The following safety precautions shall be followed when using grinding machines:

- Wear goggles regardless of whether or not machine is equipped with a transparent shield.

- Examine grinding wheels for defects prior to use.
- Grinding wheel flanges and blotting paper compression washers shall be at least one-third diameter of wheel. Flanges shall be the type which provide a bearing surface only on the outer periphery. The metal flanges must not contact the abrasive but bear against blotting paper washers which in turn contact the sides of the wheel. The inner flange shall be fixed or pegged to spindle.
- Stand to one side of grinding wheel when it is first started to avoid injury in case wheel fractures.
- When chatter occurs, stop grinder and determine cause.
- Do not exceed authorized speeds for particular grinding wheels.
- Wear suitable gloves, in addition to goggles, when buffing.

c. *Lathes.* Lathes are used in working metal of a cylindrical nature, and can perform either inside or outside work. The material is secured in the lathe chuck to provide rotary movement, then formed by contact with a stationary grinding or cutting tool. Do not machine magnesium at high speed or with a heavy feed. The following safety precautions shall be followed when using lathes:

- Cutting tools must be kept sharp.
- Allow chuck to come to a stop on its own accord. Do not use hand pressure to stop a spinning chuck.
- Do not file work while back gears are engaged, because spindle speed is too slow to keep work steady. Work will not stall if jamming occurs.
- Do not set tools while lathe or power is on. Examine tools and chucks for cracks and defects prior to use.
- Do not measure work while machine is in motion.

d. *Milling Machines* Use milling machines for shaping or dressing, cutting gear teeth, keyway slotting, splining, and similar work. These machines may be used for general purposes as well as special cutting operations. The following safety precautions shall be followed when using milling machines:

- Ensure that bed and work are clean prior to securing work to bed.
- Secure work to prevent movement during all phases of milling.
- Before setting up job, ensure that table, bore in spindle, arbor or cutter shank, and work is clean and free of chips, nicks, and burrs.
- Select a cutter of proper diameter.
- Do not change feed or speed while work is being cut.
- Lower table or raise spindle prior to moving or feeding work under a revolving cutter.
- Ensure that all clamps and bolts are low enough to pass under arbor and cutter.

e. *Shapers and Planers.* Shapers and planers have a reciprocating, single-edge cutting tool, and are used for straight-line machining, surfacing, and similar work. The following safety precautions shall be followed when using shapers and planers:

- Be sure that work is tightly bolted to table or firmly held in vise and cutter raised above work before starting machine.
- Be sure that ram has adequate clearance before starting machine.
- Personnel operating shaper shall wear goggles.
- Stop machine completely when changing tools.

f. *Miscellaneous Machine Tools.* Refer to the applicable machine maintenance manual for specific safety precautions.

g. *Portable Machine Tools.* Refer to the applicable machine maintenance manual for specific safety precautions.

2-4. Care and Use of Equipment. Care and use of equipment common to machine shops is explained in the following paragraphs.

a. *Drilling Machines.* Drilling machines, or drill presses, as shown in figure 2-1, are used to open, enlarge, and to finish holes by drilling, reaming, boring, counter-boring, countersinking, and tapping.

(1) *Types.* Many different types of drilling machines have been built for handling different classes of work to the best advantage. Some designs incorporate great versatility in handling a wide variety of different work pieces, while others facilitate the mass production of duplicate parts. Many modern drilling machines are numerically controlled; others are automatically cycled. The horsepower of drilling machines may range from a fractional horsepower for drilling small holes to as much

as fifty horsepower for driving a heavy-duty, multiple-spindle drill head that is capable of drilling many holes simultaneously. The following is a list of drilling machine types:

- Upright drilling machine.
- Sensitive drilling machine.
- Radial drilling machine.
- Turret drilling machine.
- Multiple spindle and gang drilling machine.

(2) *Operating procedures.* Refer to the specific drilling machine operators manual for operating procedures. The following are general hole drilling procedures:

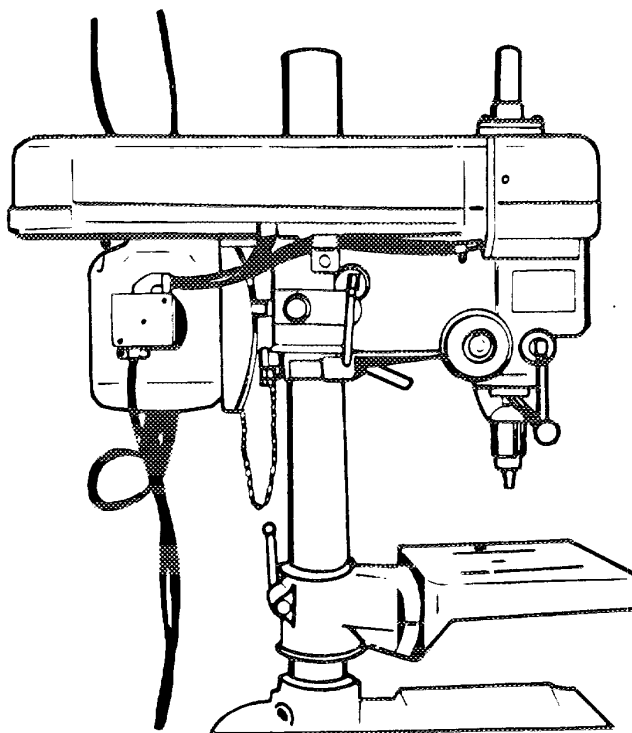

Figure 2-1. Drill Press

NOTE

Before drilling, work must be set up, a sharp drill bit of the correct size selected, and the machine set for the correct cutting speed and feed.

(a) Align drill bit with center punch mark of the hole to be drilled.

(b) Feed drill bit into piece until it has penetrated approximately two-thirds of the diameter of the drill.

(c) Remove drill bit and check the relation of the drilled spot to the scribed layout circle.

(d) When the spot and the layout circle are concentric, the hole can be drilled to the required depth.

(3) *Inspection and maintenance.* Refer to the applicable maintenance manuals for inspection and maintenance of drilling machines.

b. Bandsaws. The bandsaws, as shown in figures 2-2 and 2-3, use metal-cutting bandsaw blades to cut off to length, bar stock and structural steel sections.

(1) *Types.* The vertical contour and cutoff type bandsaws are the primary types used in aircraft maintenance. Both machines have different makes and models, but basic features are similar.

(2) *Operating procedures.* Refer to the specific bandsaw operator's manual for operating procedures. Be sure to adjust cutting speed, feed rate, and feed pressure prior to cutting.

(3) *Inspection and maintenance.* Refer to the applicable maintenance manuals for inspection and maintenance of bandsaws. Blade must be adjusted to recommended tension. Be sure to check blade tracking and alignment within saw guides.

c. Lathes. The lathe, as shown in figure 2-4, is a machine in which work is rotated about a horizontal axis and cut or shaped by a fixed tool.

(1) *Types.* The engine, turret, production, and vertical lathes are typical types used for cutting or shaping.

(2) *Operating procedures.* Refer to the specific lathe operator's manual for operating procedures.

(3) *Inspection and maintenance.* Refer to the applicable maintenance manuals for inspection and maintenance of lathes.

d. Milling Machines. The milling machine, as shown in figure 2-5, is a machine on which metal is shaped and dressed by rotating milling cutters.

(1) *Types.* Milling machines have different makes and models, but basic features are similar.

(2) *Operating procedures.* Refer to the specific milling machine operator's manual for operating procedures.

(3) *Inspection and maintenance.* Refer to the applicable maintenance manuals for inspection and maintenance of milling machines.

e. Shapers. The shaper, as shown in figure 2-6, is used to form and shape a workpiece.

(1) *Types.* Shapers have different makes and models but basic features are similar.

(2) *Operating procedures.* Refer to the specific shaper operator's manual for operating procedures.

(3) *Inspection and maintenance.* Refer to the applicable maintenance manuals for inspection and maintenance of shapers.

f. Grinders. Grinders, as shown in figure 2-7, are used to grind material to a specific tolerance.

(1) *Types:* There are two basic types of grinders: a bench type and a pedestal type. These grinders consist of an electric motor with a grinding wheel attached to each end of the motor shaft. One wheel is coarse, for rough work; the other is fine and is used for sharpening purposes.

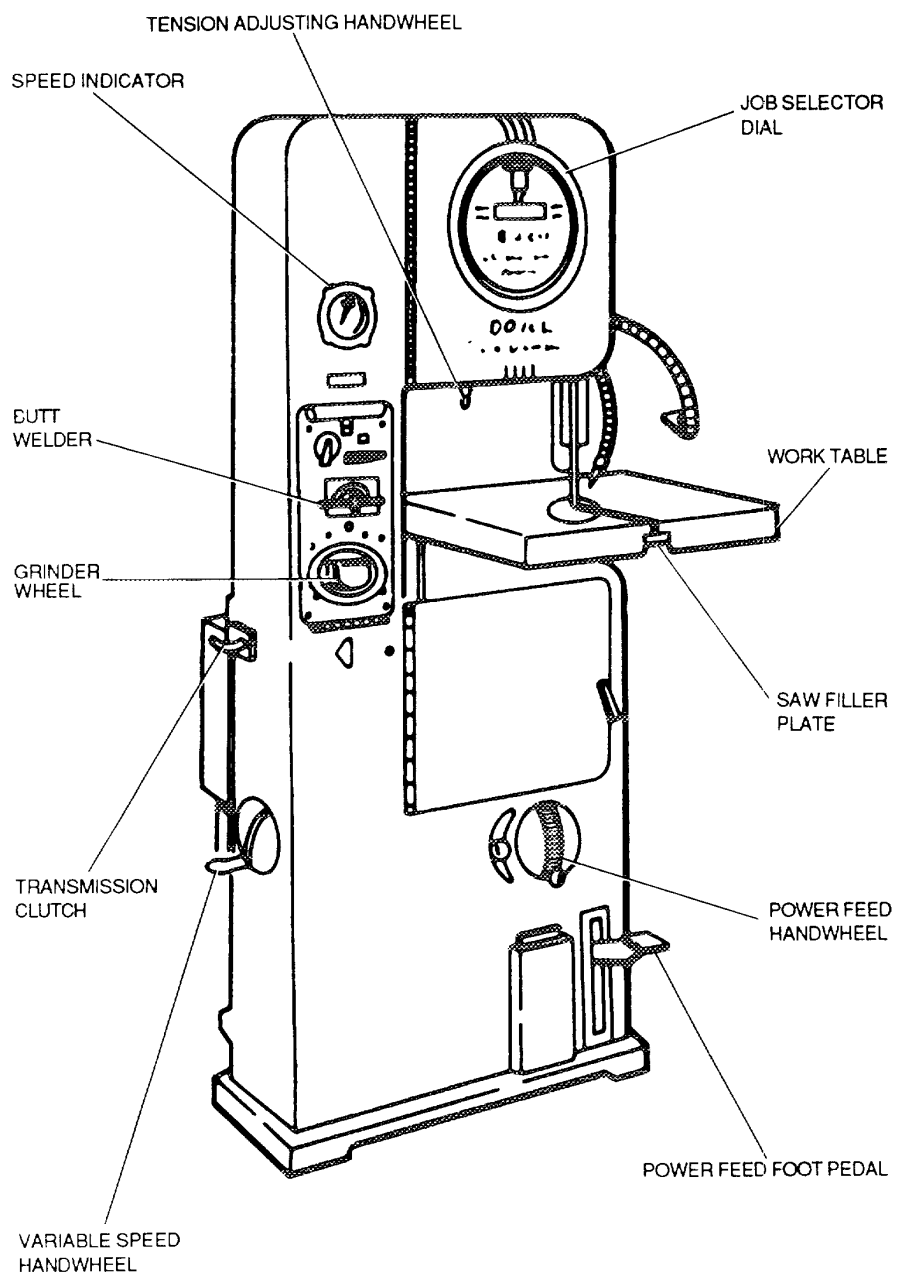

Figure 2-2. Bandsaw (Vertical - Contour)

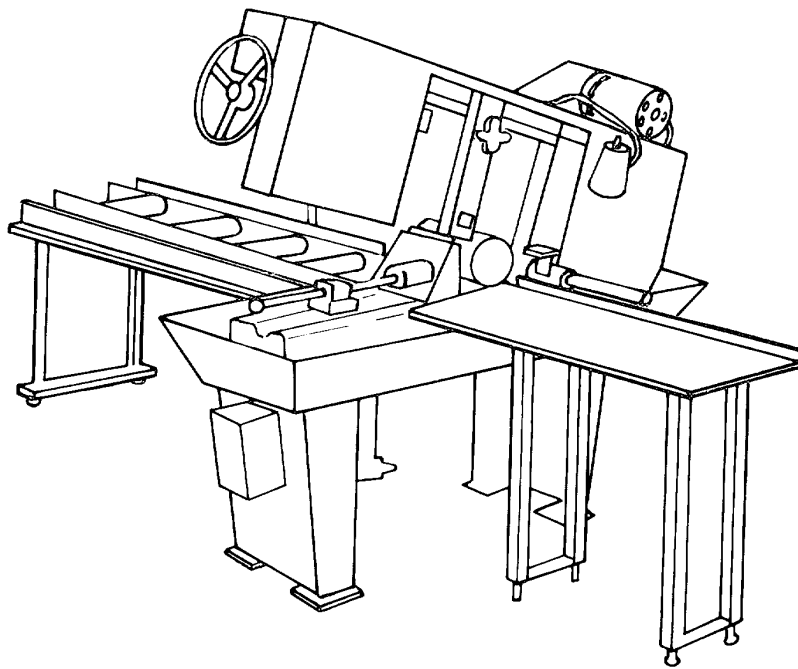

Figure 2-3 Bandsaw (Cutoff -Type)

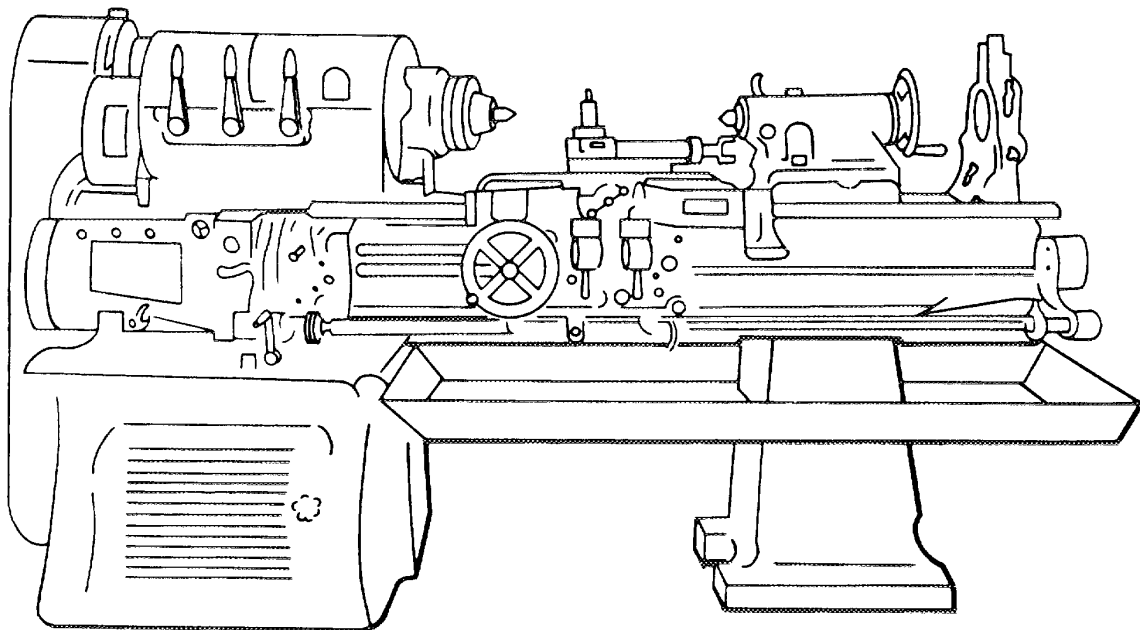

Figure 2-4. Lathe (Engine Type)

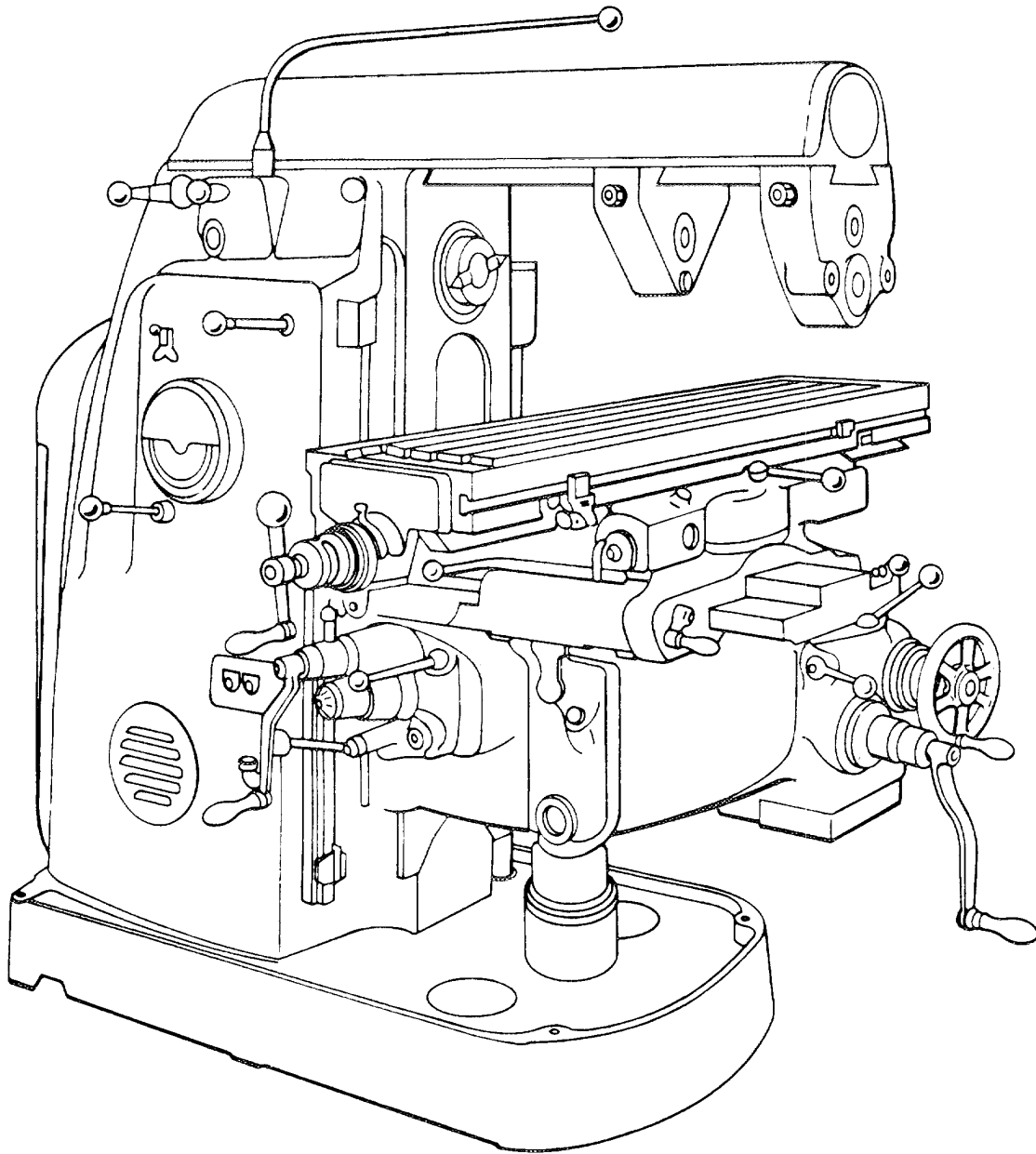

Figure 2-5. Milling Machine (Universal Type)

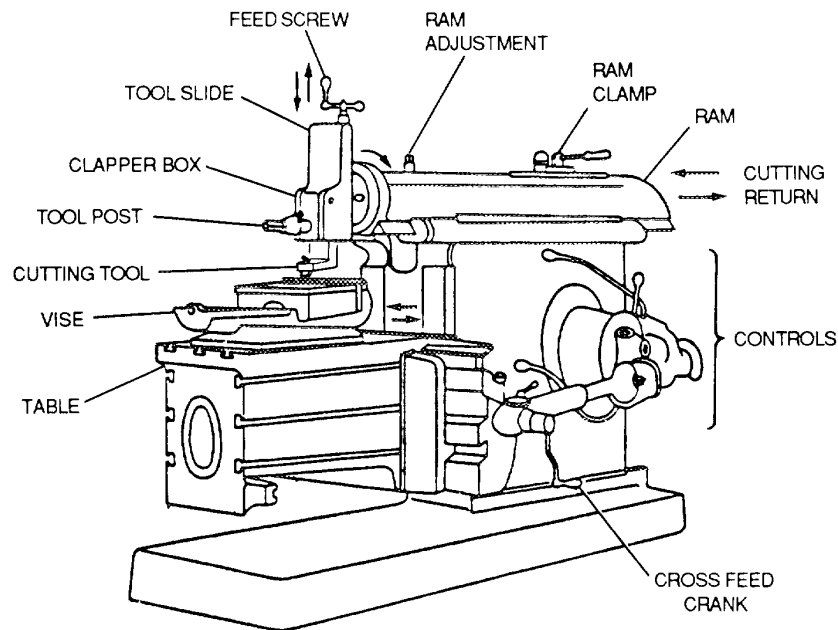

Figure 2-6. Shaper

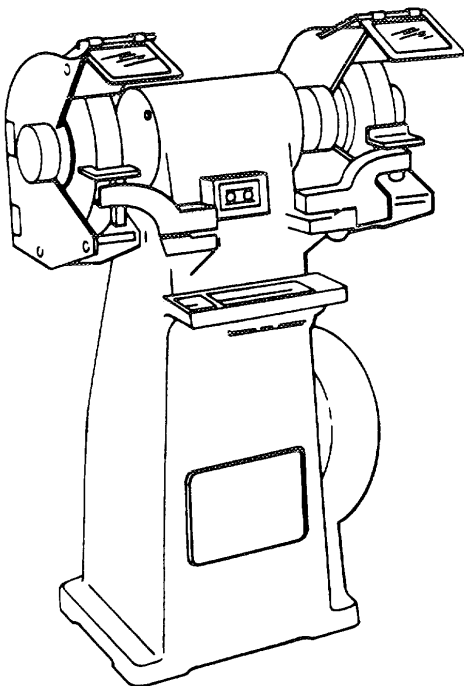

Figure 2-7. Grinder

(2) *Operating procedures.* Refer to the specific grinder operator's manual for operating procedures. The following precautions shall be adhered to in order to prevent injuries to personnel:

- Do not operate grinder unless wearing goggles.
- Do not operate grinder unless wheel guards are attached.
- Do not hold material so that fingers will touch grinding wheel.
- Do not grind soft materials such as aluminum or brass because these materials will clog the pores of the grinding wheel and stop its cutting action. A clogged or glazed wheel should be dressed to obtain proper cutting action.
- Under no condition force the work against a cool wheel without first giving the wheel an opportunity to warm up. This can cause the wheel to shatter suddenly.
- Do not continually use the side of the wheel for grinding.

(3) *Inspection and maintenance.* Refer to the applicable manuals for inspection and maintenance of grinders. The following paragraphs contain general wheel installation and dressing procedures.

(a) *Wheel installation.* The following procedures are for installing a new grinding wheel on a grinder (see figure 2-8):

CAUTION

Do not use a metallic object for testing soundness of grinding wheel. The wheel may shatter.

1 Test wheel for soundness before installation by holding wheel and tapping it with a piece of wood. A sound wheel will emit a dull ring.

2 Place blotting between wheel and wheel flanges. Wheel flanges should be of ample size.

3 Place wheel on arbor and tighten spindle nut so flanges hold wheel securely.

NOTE

Do not overtighten spindle nut because cracking of grinding wheel may result.

4 Test grinding wheel for breakage, after installing, by permitting grinder to run for a few minutes.

(b) *Wheel dressing.* Use of grinding wheel will cause the wheel to wear unevenly and not run true. Grinding wheels shall be dressed as follows in order for them to run true:

1 Place wheel dresser against wheel and move back and forth while grinder is running until wheel is trued.

2 When using wheel dresser, hold dresser against grinding wheel firmly enough to prevent sparks.

2-5. Laying Out and Mounting Work. General layout practices and mounting of work pieces are explained in the following paragraphs.

a. *General Layout Practices.* Work to be machined is laid out to establish reference lines or planes which are used to set up the part on the machine, to outline the surfaces to be machined, and to show the

approximate amount of metal to be removed from each surface. The part is painted with a blue layout dye and layout marks are scribed for reference.

b. *Mounting.* Mount work piece in machine in the manner described in the machine operator's manual. Be sure part is mounted securely to avoid slipping while machining operation is in progress.

2-6. Special Operations On Drilling Machines.

Special operations on drilling machines include tapping, reaming, counterboring and spot facing, lapping, and bearing roll staking.

a. *Tapping.* Tapping is the process of cutting inside threads in drilled holes. Provision for rapidly reversing the spindle must be made so that the tap can be backed out of the hole after the thread is cut to the required depth. Refer to the applicable operator's manual for tapping procedures.

b. *Reaming.* Reaming is done to finish drilled holes to an exact diameter with round, straight, and smooth surfaces. The reamer must be sharp and correctly ground. Refer to the applicable operator's manual for reaming procedures.

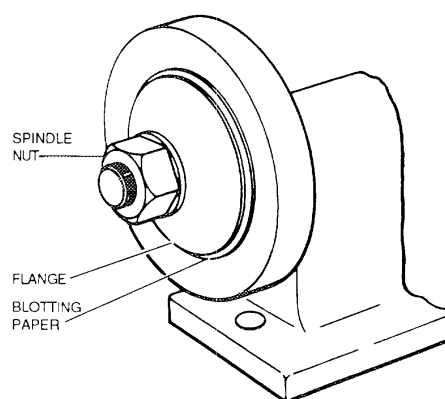

Figure 2-8. Grinder Wheel Installation

c. Counterboring and Spotfacing. Counterboring and spotfacing are used to modify existing holes. Counterboring enlarges the end of a hole by cutting a cylindrical surface concentric with the original hole to allow the bolt or screwhead to be sunk below the surface. Spotfacing cuts a smooth, flat surface which is perpendicular to the axis of the hole. This surface usually serves as a seat for the head of a bolt, cap screw, or nut. Refer to the applicable operator's manuals for counterboring and spotfacing procedures.

d. Lapping. Lapping is done to produce a geometrically true surface, improve accuracy, or provide a very close fit between contacting surfaces. Since a very minute amount of material is removed from the workpiece, lapping is the final operation.

e. Bearing Roll Staking. Slight axial movement of installed bearings can be prevented by bearing roll staking. This method of bearing retention consists of deforming the bearing housing by means of a swaging roller. Refer to the applicable maintenance manual for bearing roll staking procedures.

CHAPTER 3

WELDING SHOP PRACTICES

3-1. General. Welding is the process of joining metal by fusing the materials while they are in a molten state. The following general paragraphs describe welding shop rules, types of welding, welding materials, aluminum welding, magnesium welding, corrosion-resistant steel and nickel-chromium-iron alloy welding, welding on aircraft, and brazing and silver soldering.

3-2. Shop Rules. The practices and procedures described in this chapter pertain to the manufacturing and repair functions of aviation activities and are applicable to all levels of maintenance. Because of the many types of Army aircraft, each shop within the manufacturing and repair section must, of necessity, have personnel trained in general practices and procedures to the extent that different type and model aircraft do not upset a smooth running shop.

a. Responsibility. All supervisory personnel are responsible for a continuing and effective shop safety program. To implement and maintain this program, shop supervisors will utilize bulletin boards, signs, and any other effective method. Shop personnel will cooperate in the shop safety program by making helpful recommendations, and continually exercising care and caution in the operation of all shop equipment. All shop personnel will strive to improve the safety program and be especially alert to observe and correct hazardous conditions and unsafe shop practices. All accidents, no matter how minor, shall be reported to the shop supervisor, and all published instructions regarding safety shall be strictly adhered to. Also, safety engineers and safety officers will ensure that proper safety procedures are adhered to in accordance with AR 385-10, Army Safety Program. The Occupational Safety and Health Act of 1971, OSHA 1910.251; all applicable fire codes, NFPA 410; and other accepted civilian and military safety practices.

b. Shop Housekeeping. Housekeeping is the yardstick by which the shops are judged. A clean, well-arranged shop is a safe shop and reflects credit on all personnel concerned with its operation. The following shop practices shall be observed:

(1) Oil pans or drip pans shall be used where leaking oil, grease, and similar materials may cause

hazardous accumulations on equipment or floors. All spills shall be cleaned up immediately. Approved sweeping compound may be used to remove these materials from the floor.

CAUTION

Floors shall not be cleaned with volatile or flammable liquids. Fire hazard which may damage equipment may result.

(2) Floors shall be maintained smooth and clean, free of all obstructions and slippery substances. Holes and irregularities in floors shall be repaired to maintain a level surface free from tripping hazards.

(3) All unnecessary materials on walls shall be removed and projections shall be kept to a minimum.

(4) Aisles shall be clearly defined and kept free of hazardous obstructions. Where possible, aisles shall be suitably marked by painting.

(5) All machines, work benches, aisles, etc., shall be adequately illuminated.

c. Safety. The various types of welding operations create numerous health and fire hazards unless proper precautions are exercised. The harmful light rays produced by welding flames and arcs may seriously injure the eyes and burn the skin. Poisonous fumes and gases which may cause serious illness are produced in welding operations. The skin may be burned by splashing metal, hot sparks, welding flame or arc, and hot objects which are handled. Severe electric shock is possible from electrically powered welding apparatus. The flame- and heat-producing aspects of welding create a serious fire and explosion hazard wherever welding is done in the vicinity of flammable liquids and gases. In view of the numerous possibilities for injury and damage in welding operations, it is essential that safe practices and standards be observed. The following paragraphs explain welding safety practices.

(1) *Personnel protective equipment.* Suitable personal protective clothing and equipment shall be worn by personnel performing welding operations. Helmets, shields, aprons, gloves, gauntlets, or other items of clothing of approved design may be used. Goggles shall be carefully selected on the basis of lens shade which will provide complete protection for type of welding involved.

(2) *Ventilation.* Forced ventilation should be provided when natural ventilation is inadequate to keep concentration of injurious fumes produced in welding operation below harmful levels. Suitable respiratory equipment shall be worn when concentration of injurious fumes cannot be kept below maximum allowable concentrations.

(3) *Fire hazard.* Welding shall not be permitted in the vicinity of flammable or explosive substances. A suitable fire extinguisher shall be provided for all welding units.

(a) *Flammable material.* All flammable material shall be removed from the immediate vicinity of welding operations. Wooden floors and other combustible material which may be subjected to excessive heat or contact with the flame shall be adequately protected. Where removal of flammable material is impractical, a suitable fire-resistant shield shall be placed between flammable material and welding operation. A thorough inspection of surrounding area shall be made upon completion of a welding operation to detect any potential fire.

(b) *Explosive hazards.* Welding shall be prohibited where flammable liquids and gases create a fire or explosion hazard. In confined areas with inadequate ventilation, it is possible for the welding operation itself to produce flammable and explosive gases.

(c) *Fire protection.* Where a fire hazard continues to exist despite reasonable precautionary measures, a fire guard provided with suitable fire extinguishing equipment shall be stationed near welding location.

(4) *Welding of containers.* Tanks, cylinders, and other containers shall never be welded until it has been ascertained that they do not contain flammable or explosive substances.

(a) *Sealed containers.* Sealed containers shall not be worked on until it has been determined that

their contents do not present a hazard and venting is provided.

(b) *Draining.* Prior to welding gas tanks and other containers which have contained flammable liquids, all liquid shall be drained from tank. Precautions shall be taken to prevent draining process from creating a fire hazard. The tank shall then be thoroughly washed, steamed, and filled with water. Provide a vent to permit release of pressure which is generated in tank by heat of welding process. Accomplish repairs as soon as possible after tank has been drained and cleaned.

3-3. Types of Welding. There are three general types of welding: gas, electric arc, and spot welding. The following paragraphs describe the three types.

a. *Gas Welding.* Gas welding is accomplished by heating the ends or edges of metal parts to a molten state with a high temperature flame. The flame is produced with a torch burning pure oxygen with acetylene or hydrogen. The metals, when in a molten state, flow together to form a union.

(1) *Gas welding precautions.* The oxygen, acetylene, and the flame used in oxyacetylene welding requires careful handling to prevent injury or damage. Observe the following precautions:

- Do not allow oil or grease to contact welding apparatus. Oil or grease in contact with oxygen equipment, in particular, is extremely dangerous and may result in fire or explosion.
- Do not use acetylene from cylinders at pressures in excess of 15 psi. The special T-wrench provided for opening acetylene cylinders will be left in place while cylinder is in use to permit quick shutoff in an emergency.
- Acetylene and oxygen cylinders will be hand- led with care to prevent damage to cylinders, regulators, or valves. Cylinder valves will be in an immediately accessible location when cylinders are in use to permit quick shutoff in
- an emergency. All cylinders to which a hose is not attached will be provided with protective caps.
- Protect hose from mechanical damage or con- tact with hot metal, open flame, and other destructive agents. Inspect hose periodically for leaks by submerging in water. Do not use a flame to test for leaks. Use only standard ferrules or clamps to secure hose to nipples.

- Do not permit flame to contact welding equipment or apparatus. Maintain careful control of welding flame to prevent burns or fire. Keep flame within field of vision of the welder.
- Do not leave torch burning when not in use. Close torch valve when there is no burning.
- Shut off both valves of torch and examine welding tip for obstructions if flashback occurs. Flashback is the momentary extinguishing of the welding flame followed by a rapid re-ignition causing a brief flash and sharp popping noise. A common cause of this condition is clogging of the welding tip by inadvertent contact of the tip with the metal being worked.
- Shut off regulator valves immediately if a hose bursts or escaping gas is ignited.

(2) *Gas welding equipment.* Gas welding equipment consists of torches, tanks, gauges, and hoses, as shown in figure 3-1.

(3) *Inspection and maintenance.* Inspect and maintain gas welding equipment using the following general procedures:

(a) Clean torches externally with hot water and dry with a clean cloth. Clean internally by blowing out from both ends using compressed air.

(b) Tips should be blown out from both ends and orifice should be cleaned out with appropriate tip reamer which is furnished.

(c) Clean hose with warm soapy water and examine for leaks at same time by putting pressure on hose.

(d) Examine regulators frequently for leakage.

b. *Electric Arc Welding.* Electric arc welding is a fusion process based on the principle of generating heat with an electric arc jumping an airgap to complete an electrical circuit. Various methods are used for electric arc welding.

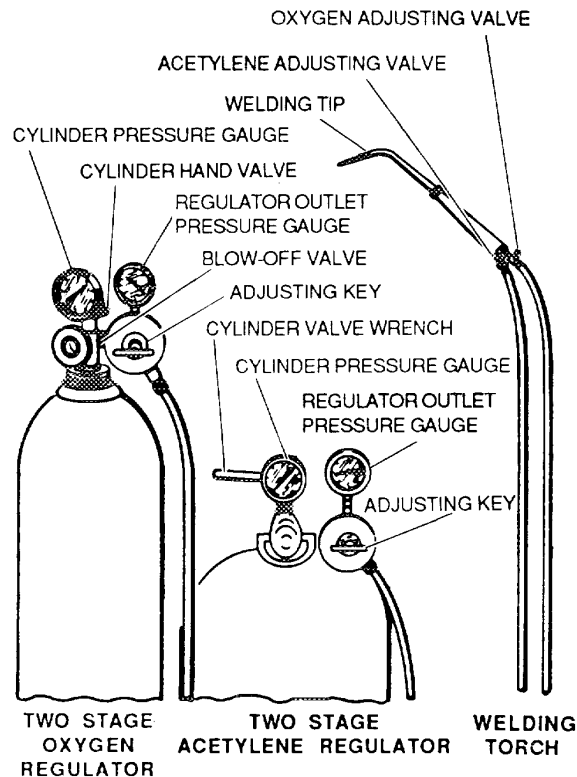

Figure 3-1. Gas Welding Equipment.

(1) *Electric arc welding precautions.* Observe the following precautions:

- Curtains or screens to prevent flash injury to eyes shall be provided around arc welding locations where shop personnel are working.
- When connecting ground cable, make sure that the welding current path will not pass through moving parts including bearings, gears, or anything which could be damaged by electric current.
- Circuits on electric arc welding machines shall be examined only when circuits are dead.
- Do not operate polarity and rotary switches while welding equipment is under load.
- Provide an adequate power ground to motor generator and other electrical welding apparatus.

Major repairs to electrical equipment shall be performed by qualified electricians only.

(2) *Electric arc welding equipment.* Typical electric arc equipment is shown in figure 3-2.

(3) *Inspection and maintenance.* All equipment shall be inspected periodically. Cables shall be examined for defects and loose connections and defective electrode holders shall be replaced. Examine welding terminals for burning or pitting. Tighten all loose connections and replace damaged cables. Refer to the applicable operation and service instructions manual for specific maintenance of particular type equipment.

c. *Spot Welding.* Spot welding is a resistance welding process that fuses metal together using the heat obtained from the resistance to the electric current flow passing through the workpieces.

(1) *Spot welding equipment.* A schematic of spot welding equipment is shown in figure 3-3.

(2) *Inspection and maintenance.* All equipment shall be inspected periodically. Repair damaged equipment in accordance with the applicable maintenance manual.

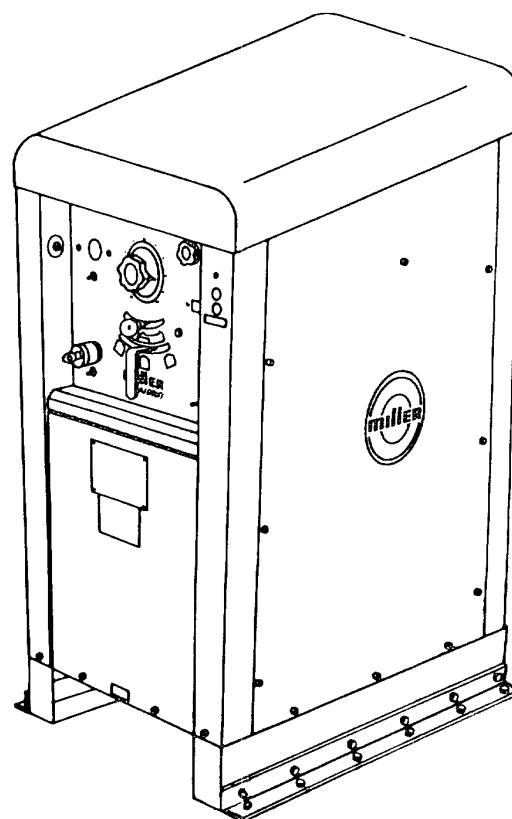

Figure 3-2. Electric Arc Welding Equipment

3-4. Welding Materials. Electrodes, welding rods, and fluxes are described in the following paragraphs.

a. *Electrodes.* Metal-arc electrodes may be grouped and classified as bare electrodes, thinly coated electrodes, and shielded arc or heavy coated electrodes. The type used depends on the specific properties required in the weld deposited, such as: corrosion resistance, ductility, high tensile strength, etc.; the type of base metal to be welded; the position of the weld (i.e., flat, horizontal, vertical, or overhead); and the type of current and polarity required. Steel, aluminum, and magnesium electrodes are described in table 3-1.

b. *Welding Rods.* Welding rods are made for various types of carbon steel, cast iron, aluminum, bronze, stainless steel and other metals, and for hard surfacing. Welding rods for the different types of welding are given in table 3-2.

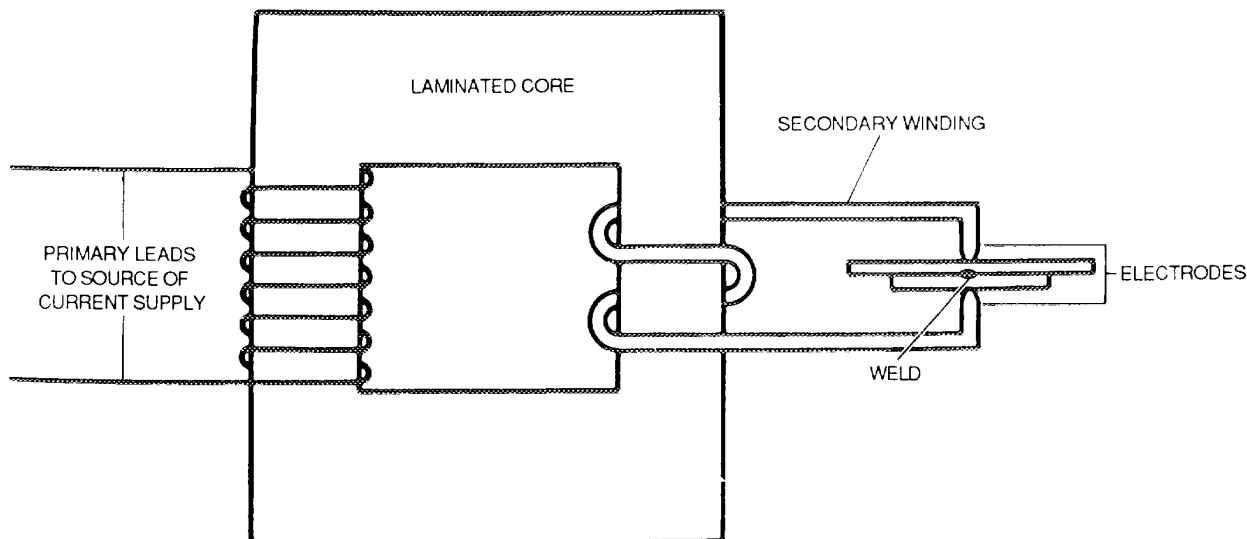

Figure 3-3. Welding Equipment Schematic

c. Fluxes. Fluxes are used to clean and promote the fusion process when welding. Different fluxes are used for various types of metal. Mix fluxes in accordance with instructions on container.

3-5. Aluminum Welding. The following paragraphs cover types of aluminum alloys which can be welded, cleaning procedures, and procedures for gas, arc, and spot welding.

a. Types of Alloys. Aluminum alloys 1100, 2219, 3003, 5052, 5083, 5086, 5454, 5456, and 6061 may be welded by the use of gas, arc, or spot weld.

b. Cleaning. Parts to be welded should be cleaned and deoxidized using the following procedures:

(1) Immerse part in solution of 4 to 6 ounces of alkaline cleaner, MIL-C-87936, per gallon of water, maintained at a temperature of 180 to 200°F (82 to 93°C), for 5 minutes.

(2) Rinse part in cold water.

(3) Immerse for 1 minute in a solution of 15 to 17 ounces of aluminum deoxidizer (Aldox) or equivalent, per gallon of water.

(4) Rinse in water heated to temperature of 170 to 190°F (77 to 88°C), and air-dry.

(5) Measure contact surface resistance with a micrometer. Contact surface resistance must be less than 1000 microhms.

(6) Deoxidize parts by one of the following methods when the inert-arc process is to be used.

(a) The chemical method consists of immersing the part in a solution of 10 percent nitric acid, Federal Specification O-N-350, and 0.25 percent hydrofluoric acid, MIL-A-24641, for 5 minutes. Rinse in hot water and dry with compressed air.

(b) The mechanical method consists of abrading the edges to be welded 1-1/2 inches deep on both sides.

c. Aluminum Gas Welding. The following paragraphs describe aluminum gas welding practices and procedures.

(1) Material thickness requirement. Gas welding should be confined to materials from 0.031 to 0.125 inch in thickness.

(2) Edge preparation. On thin material up to about 1/16 inch thick, edges should be formed to a 90-degree flange about the same height as the thickness of the material or higher.

Table 3-1. Electrodes

Electrode material	Sizes	Class	Specification	Polarity	Electrode	Work	Use
Nickel Chromium Iron Alloy (Inconel)	1/16, 3/32, 1/8, and 5/32 inch	ENiCrFe-5	AWS A5.14	Reverse	Positive	Negative	Joining of nickel chromium iron alloy to corrosion-resistant steel
Steel	5/64, 3/32, 1/8, 5/32, and 3/16 inch	E6012	AWS A5.1	Straight	Negative	Positive	Weldable low and mild carbon steels on poor fit-up in all positions
Steel	1/8, 5/32, and 3/16 inch	E7014	AWS A5.1	Reverse	Positive	Negative	Weldable low and mild carbon steels on poor fit-up in all positions
Steel	5/64 and 3/32 inch	E10013	MIL-E-6843	Straight	Negative	Positive	Welding of chrome-molybdenum (4130) and chrome-nickel-molybdenum (NE8630)
Steel	1/8 and 5/32 inch	E10020	MIL-E-6843	Reverse	Positive	Negative	Same as Class E10013 except used where deeper penetration is desired
Steel	5/64, 3/32, 1/8, and 5/32 inch	Class 5 Type 347	MIL-E-22200/2	Reverse	Positive	Negative	Welding 18-8 corrosion- and heat-resistant steels conforming to MIL-S-6721
Steel	1/8 inch	Class B	57-203-5	Reverse	Positive	Negative	Refacing of worn edges of cutting tools and dies
Aluminum	3/32, 1/8, 5/32, and 3/16 inch	E1100 E3003 E4043	MIL-E-15597	Reverse	Positive	Negative	Welding of aluminum and aluminum alloys

Table 3-1. Electrodes (Continued)

Electrode material	Sizes	Class	Specification	Polarity	Electrode	Work	Use
Aluminum	1/4 and 3/64 inch		AWS A5.10	Reverse	Positive	Negative	Semiautomatic and machine MIG welding of aluminum alloys
Aluminum	3/16 inch		EUTECTIC No. 2101E	Reverse	Positive	Negative	Heavy aluminum castings, long joints and filler
Magnesium	3/32, 1/8, 3/16 and 1/4 inch		AWS A5.19	Reverse	Positive	Negative	Magnesium-aluminum-zinc alloys

Table 3-2. Welding Rod Information

Type rod	Type or grade	Class	Specification	Use
Aluminum		R1100	AWS A5.10	1100 and 3003 only
Aluminum Alloy		R4043	AWS A5.10	4043, 5052, 6053, and 6061
Brass	Type I	RBCuZn-A	QQ-R-571	Brass
Bronze	Type I	RBCuZn-C	QQ-R-571	Brass, bronze, alloy steels and cast steels
Cast Iron		WD-G112	57-203-4	Gray iron and other low stressed iron castings
Chromium, Cobalt, Tungsten		WD-RCOCRW-1	57-203-12	Steel tail skid shoes
Magnesium Alloy	Grade A		AWS A5.19	Sheet, extrusions, tubing, and castings of Grade A
Magnesium Alloy	Grade C		AWS A5.19	Sheet, extrusions, tubing, forging, and castings magnesium aluminum, zinc composition
Nickel, Chromium, Iron Alloy (Inconel)		RNiCrSe-5	AWS A5.14	Gas welding of nickel chromium iron alloy in annealed condition only
Nickel, Chromium, Iron Alloy			AWS A5.9	Arc welding of 18-8 corrosion-resistant steels
Steel	Type I Grade 3E	1	MIL-R-5632	General purpose welding of low and mild carbon steels
Steel	Type II Grade 3G	2	MIL-R-5632	Gas welding of chrome-molybdenum (4130) and chrome-nickel-molybdenum (NE 8630)
Steel, Corrosion-Resistant	347		AWS A5.9	18-8 and 19-9 Corrosion- and heat-resistant steels

TM 1-1500-204-23-8

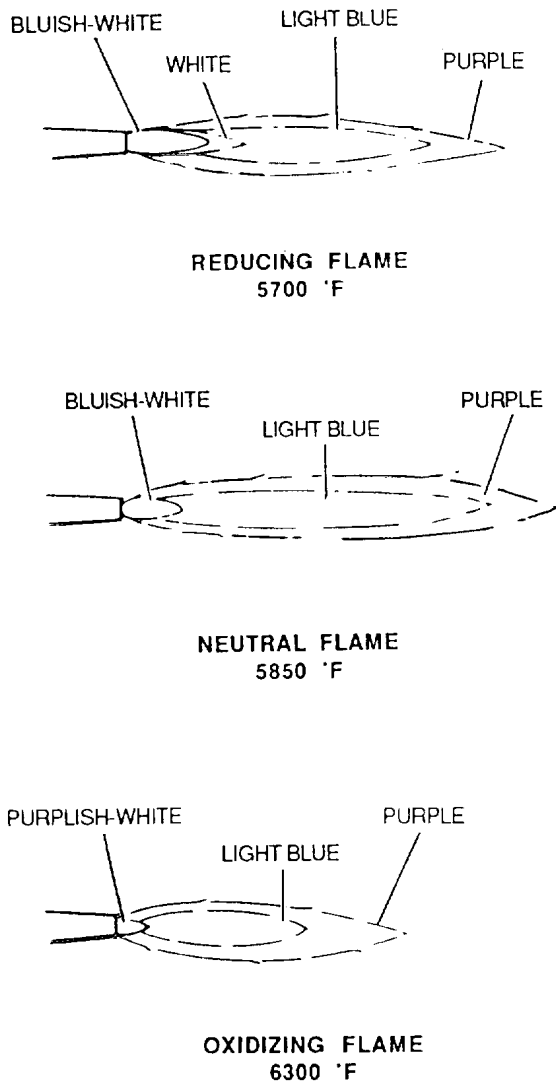

Figure 3-4. Gas Welding Flames

(3) *Jigs.* Use jigs designed to minimize heat loss using point contact. All contact points should be rounded, including holddown clamps, to permit aluminum to expand while materials are being welded. It is also desirable to tack weld whenever possible.

(4) *Flame adjustment.* The welding flame, as shown in figure 3-4, should be neutral in order to achieve the best speed and a clean weld of good soundness.

(5) *Welding technique.* Gas weld using the following procedures:

(a) Apply flux to welding rod and surface to be welded.

(b) Pass flame over starting point in small circles until flux melts.

(c) Scrape rod over surface at about 3- to 4-second intervals, permitting rod to come clear of flame each time, otherwise rod will melt before parent metal and it will be hard to note when welding should start.

(d) After flux melts, base metal must be melted before rod is applied.

NOTE

The forehand method of welding is best for aluminum because the flame points away from the complete weld and preheats the edges to be welded.

(e) Remove flux residue by scrubbing with a bristle brush and hot water; immerse part in a 10 percent solution of sulfuric acid, Federal Specification O-S-809, rinse, and dry with compressed air.

(f) Visually examine completed weld for cracks, porosity, fusing defects, and undercutting. Chip and grind out damaged welds before rewelding.

NOTE

Never use a torch to remove a weld.

d. Aluminum Arc Welding. Arc welding should be accomplished using inert gas to shield the arc. The use of inert gas as a shield produces a clean, sound weld without the use of corrosive fluxes. Defects, probable causes, and remedies are given in table 3-3.

(1) *Gas.* Use either argon or helium for the shield. Argon, MIL-A-18455, is the preferred gas.

(2) *Electrodes.* Electrodes used for arc welding should conform to AWS A5.10. Use electrodes according to the following procedures:

(a) Hold electrode in a nearly vertical position.

(b) Move electrode along seam in a straight line at a uniform rate.

Table 3-3. Arc Welding Defects, Causes, and Remedies

Defects	Probable cause	Remedy
1. Porous welds	a. Short arc	Hold longer arc. Use proper electrode.
	b. Insufficient puddling time	Allow sufficient puddling time for gases to escape.
	c. Impaired base metal	Remove impurities in base metal.
	d. Incorrect current	Use proper current.
	e. Improper welding technique	Use weaving motion to eliminate pin holes.
2. Incomplete penetration	a. Speed too fast	Weld slowly enough to get good root penetration.
	b. Electrode too large	Select electrode according to welding groove size.
	c. Current too low	Use sufficient current.
	d. Faulty preparation	Calculate electrode penetration properly. Leave proper free space at bottom of weld.
3. Warping	a. Shrinkage of weld metal	Use intermittent welds. Control cooling.
	b. Faulty clamping of parts	Clamp parts properly.
	c. Faulty preparation	Peen joint edges before welding. Space parts properly.
	d. Overheating at joints	Increase travel speed. Use high speed, moderate penetration electrodes.
4. Poor fusion	a. Incorrect speed	Use correct speed.
	b. Current improperly adjusted	Use proper current to allow deposition and penetration.
	c. Faulty preparation	Use proper cleaning, edge preparation, and positioning.
5. Poor fusion	a. Improper electrode size	Select proper electrode.
	b. Improper welding technique	Weave must be sufficient to meld sides of joint. Prevent weld metal from curling away from plates.

Table 3-3. Arc Welding Defects, Causes, and Remedies - CONT

Defect	Probable cause	Remedy
6. Distortion	a. Uneven heating	Distribute welding properly.
	b. Improper sequence	Examine structure and use proper sequence.
	c. Deposited metal shrinks	Tack or clamp parts properly. Form parts before welding. Dispose of rolling or forming strains before welding.
7. Cracked welds	a. Wrong electrode	Use proper electrode.
	b. Weld and part sizes unbalanced	Adjust weld size to part size.
	c. Faulty welds	Make sound welds with good root fusion.
	d. Faulty preparation	Heat parts before welding. Allow joints a proper and uniform free space.
	e. Rigid joint	Design structure and welding procedure to eliminate rigid joints. Weld from center toward edges.
8. Poor appearance	a. Faulty connections	Use a uniform weave.
	b. Overheated	Avoid overheating. Improper use of electrode and travel speed.
	c. Wrong arc and current voltage	Avoid overly high current.
9. Undercutting	a. Faulty electrode manipulation	Use a uniform weave in butt welding. Avoid excess weaving. Hold electrode at safe distance from vertical plane in making horizontal fillet weld.
	b. Improper electrode	Avoid using overly large electrodes.
	c. Current too high	Use moderate current and weld slowly.

TM 1-1500-204-23-8

(c) Welds should be made in one pass whenever possible.

(3) *Striking the arc.* The following procedures are for striking the electric arc when arc welding aluminum.

(a) Brush electrode over surface of base metal like striking a match, as shown in figure 3-5. Attempts to strike an arc by touching electrode to the piece to be welded will usually cause sticking.

NOTE

A short arc (1/8 to 3/16 inch) is most desirable.

(b) When arc goes out, restart arc 1/2-inch back of preceding crater to avoid burning through sheet.

e. *Aluminum Spot Welding.* The following paragraphs describe aluminum spot welding practices and procedures. Confine spot welding to alloys 1100 and 3003, and Alclads 2219, 5052, 5083, 5086, 5454, 5456 and 7075.

(1) *Preparation.* Position equipment and controls to prevent current flow until force is applied to the electrodes.

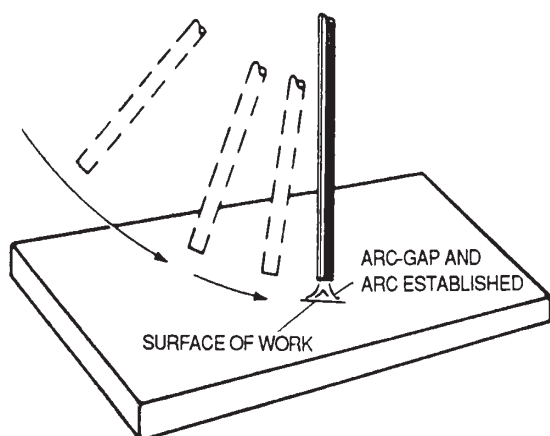

Figure 3-5. Brush Method of Starting Electric Arc.

(2) *Spot spacing.* Spacing will not exceed $\pm 1/8$ inch between welds in the same row and $\pm 1/16$ inch between welds in adjacent rows.

(3) *Joint thickness.* Joint thickness must not exceed four times the thickness of the thinner material.

NOTE

Do not join more than two sections of the material by one spot weld.

(4) *Machine settings.* Machine settings are given in the applicable maintenance manual.

(5) *Weld sequence.* Start all welds at center of sheet and work toward each end.

3-6. Magnesium Welding. Welding of magnesium can be accomplished by the use of gas, arc, or spot weld, depending on the alloy, nature of the parts, and the end usage. The following paragraphs cover cleaning procedures and procedures for gas, arc, and spot welding.

WARNING

The vapors from some chlorinated solvents (e.g., carbon tetrachloride, trichloroethylene, and perchloroethylene) break down under the ultraviolet radiation of an electric arc to form a toxic gas. Avoid welding where such vapors are present. Furthermore, these solvents vaporize easily and prolonged inhalation of the vapor can be hazardous. These organic vapors should be removed from the work area before welding is begun.

a. *Cleaning.* Clean oil, grease, and dirt from area to be welded using acetone or denatured alcohol. After cleaning, remove oxide or chemical treatment using steel wool. Sand, mill, or file abutting edges to give a clean, smooth surface and to remove edges left by shearing.

b. *Magnesium Gas Welding.* Oxyacetylene, oxyhydrogen, or oxycarbohydrogen gas may be used for this method of welding. Oxycarbohydrogen is the preferred gas. Limit gas welding to butt or corner joints because the flux is an active corroding agent and must not become entrapped in the weld. The following paragraphs describe magnesium gas welding practices and procedures.

(1) *Joint preparation.* Prepare joints using the following procedures:

(a) Stock less than 0.040-inch thick may be flanged 1/16 to 1/8 inch.

(b) Sheets 0.040- to 0.125-inch thick are simply butted together leaving 1/16- inch gap.

(c) Sheets thicker than 0.125 inch should be beveled to a 90-degree vee, leaving 1/16-inch root-face.

(2) *Flame adjustment.* Use a neutral flame. Gas pressure and orifice diameter vary with thickness of material (refer to table 3-4).

(3) *Jigs.* Secure all work in jigs.

CAUTION

In case of a magnesium fire, use clean, dry sand or talcum powder, Federal Specification A-A-42, or clean, dry, unrusted cast iron chips. Sprinkle a 1/2-inch layer over area. Do not use water or any standard liquid or foam-type fire extinguisher: an explosion may result.

(4) *Tack weld.* After brushing on flux, tack weld at intervals of 1-1/2 to 3 inches.

(5) *Finish weld.* Finish weld using the following procedures:

(a) Preheat workpiece using a fanning action with the torch. This procedure gradually fuses the flux .

(b) Hold rod in outer flame until base metal starts to melt, forming a puddle.

(c) Move torch along in a straight line as rapidly as possible.

(d) Dip rod into puddle intermittently.

(e) Lift torch slowly at end of welded seam to avoid rapid cooling.

NOTE

When any part of weld starts to burn, welding should be stopped and burned area scraped, cleaned, and reflowed before resuming.

(6) *Buckling.* If buckling or warping of seam welds in flat sheets occurs, use the following procedures:

(a) Straighten minor warping by hammering with a wood or leather mallet.

(b) Large distortions must be preheated to 600 to 700° F (316 to 370° C) before hammering.

(7) *Post cleaning.* As soon as work has become cool enough to handle, clean using the following procedures:

Table 3-4. Guide to Regulation of Gas Welding Equipment

Metal thickness (inches)	Rod diameter (inches)	Oxygen pressure (psi)	Orifice diameter (inches)	Pressure (psi)	Orifice diameter (inches)	Pressure (psi)
0.020	1/16-3/32	1-4	0.035	1-3	0.040	1-4
0.032	1/16-3/32	3-5	0.035	1-3	0.046	3-5
0.040	3/32-1/8	3-5	0.035	1-3	0.059	3-5
0.051	3/32-1/8	3-5	0.035	1-3	0.059	3-5
0.064	3/32-1/8	3-5	0.040	3-5	0.059	3-5
0.072	3/32-1/8	3-5	0.040	3-5	0.059	3-5
0.081	3/32-1/8	3-5	0.046	3-5	0.059	3-5
0.091	1/8-5/32	3-5	0.046	3-5	0.067	3-5
0.128	1/8-5/32	3-5	0.059	3-5	0.081	3-5

(a) Wash and scrub weld in hot running water until all traces of flux have been removed.

(b) Immerse part for one minute in chromepickle solution with the following composition:

Sodium dichromate 1 1/2 pounds
Nitric acid 1 1/2 points
Water to make 1 gallon

Wash in cold running water.

(c) Boil welded part for 2 hours in a solution of 8 ounces of sodium dichromate in 1 gallon of water. Rinse in cold water, followed by dipping in boiling water. Air dry the part.

(8) *Inspection.* Examine weld for cracks, porosity, excessive flux inclusion, and similar defects.

c. *Magnesium Arc Welding.* Arc welding may be used for all type joints commonly used on steel. This type weld is approximately five percent stronger than other type welds. The following paragraphs describe magnesium arc welding practices and procedures.

(1) *Joint preparation.* Prepare joints using the following procedures:

(a) Sheets from 0.125 to 0.250 inch thick should be scarfed or beveled.

(b) Sheets more than 0.250 inch thick should be scarfed on both sides.

(2) *Gas.* Use argon, MIL-A-18455, or helium, for shrouding the arc.

(3) *Electrodes.* Tungsten, ranging in size from 3/32 to 1/2 inch, should be used. Electrode should not extend any farther from gas shielding cup than necessary, about 1/4 to 3/8 inch.

(4) *Machine settings.* Suggested settings for good operation are given in table 3-5. Currents shown are for all alloys except magnesium, Federal Specification QQ-M-44, which requires 5 to 10 amperes more current for stock up to 0.050 inch and 15 to 30 amperes more current for thicker material. Sheets thicker than 0.150 inch should be welded in more than one pass, using 60 amperes on first pass and current shown in table 3-5 for subsequent passes. Argon requires 1/3 to 1/2 flow of helium.

(5) *Arc welding procedures.* Arc weld magnesium using the following procedures:

(a) Strike arc on magnesium surface.

(b) When metal becomes molten under arc, advance filler rod arc. Do not push arc into puddle.

(c) Move torch and rod along at a constant speed.

(d) Flow of inert gas should be continued for several seconds after extinguishing arc to prevent excessive oxidation.

(e) When welding sections differ greatly in thickness, heavier sections should be preheated with a gas torch to 350° F (177° C).

(6) *Defect repairs.* Repairs for defects encountered while arc welding magnesium are explained in the following paragraphs.

(a) *Cracking.* When cracking is encountered, starting and stopping plates may be clamped at each end of seam. Weld is started in one plate and continued along joint to other plate in one continuous operation.

(b) *Warping.* Warpage may be overcome by heating to a temperature not exceeding 500° F (260° C) and then pressing or hammering with a wood or leather mallet.

(c) *Stress relief.* In case of stressed functional parts, stress relief is accomplished by securing assembly in a suitable jig and heating, as shown in table 3-6. After heating, cool in air free from drafts.

(7) *Post cleaning.* Clean weld with a wire brush.

(8) *Inspection.* Examine weld for porosity, inclusions, cracks, undercutting, overcutting, overlapping, and similar defects.

d. *Spot Welding.* Spot welding should be used in low stress applications such as secondary or noncritical aircraft structures. The following paragraphs describe magnesium spot welding practices and procedures.

Table 3-5. Machine Settings for Arc Welding Magnesium

Metal thickness (inches)	Current (amperes)	Rod diameter (inches)	Electrode diameter (inches)	Helium flow (cfm)	Helium pressure oz./sq. in	Cup size (inches)
0.030	20	1/16	3/32	0.3	6	7/16
0.040	30	1/16	3/32	0.3	6	7/16
0.050	35	3/32	1/8	0.3	6	7/16
0.060	45	3/32	1/8	0.3	6	7/16
0.070	55	1/8	3/16	0.3	6	7/16
0.080	60	1/8	3/16	0.3	6	7/16
0.090	65	1/8	3/16	0.3	6	7/16
0.100	70	1/8	3/16	0.3	6	7/16
0.125	75	1/8	3/16	0.3	6	7/16
0.150	80	5/32	3/16	0.3	6	7/16
0.200	90	5/32	1/4	0.5	12	5/8
0.250	100	5/32	1/4	0.5	12	5/8
0.500	115	5/32	1/4	0.5	12	5/8
1.000	130	5/32	1/4	0.5	12	5/8

Table 3-6. Stress Relieving Treatment

Alloy specification	Condition	Temperature °F ± 10°	Time at temperature
QQ-M-31	O	500	15 Minutes
QQ-M-31	H24, H26	400	1 Hour
QQ-M-44	O	500	15 Minutes
QQ-M-44	H24, H26	265	1 Hour
QQ-M-44	O	500	15 Minutes
QQ-M-44	H24, H26	400	1 Hour

(1) *Cleaning.* Clean electrodes frequently by polishing with abrasive cloth, Federal Specification P-C-451, to avoid pickup.

(2) *Machine settings.* Use the settings furnished by the manufacturer as a guide.

(3) *Spot spacing.* Spacing between spot welds should not be less than eight times sheet thickness, with 1/4 inch minimum. Preferred spacing is 16 times sheet thickness. Edge distance should be at least four times sheet thickness, with 3/16 inch minimum. Preferred distance is six times sheet thickness.

3-7. Corrosion-Resistant Steel and Nickel Chromium Alloy Welding. The gas, arc, and spot methods may be used for welding steels. The following paragraphs cover distinguishing between corrosion-resistant steels and nickel-base alloys, special welding considerations, and procedures for gas, arc, and spot welding.

a. *Distinguishing Corrosion-Resistant Steels and Nickel-Base Alloys.* The following test procedures will enable the mechanic to identify the class of material:

TM 1-1500-204-23-8

WARNING

Hydrochloric acid is highly toxic and corrosive. Goggles, rubber gloves, and rubber aprons should be worn when handling the acid and the acid solution. Do not inhale gases and mists. When spilled on the body or clothing, wash immediately with large quantities of cold water, and seek medical help. Do not pour water into acid when preparing the solution; instead, pour acid into water. Always mix acid and water slowly. Perform operations only in well-ventilated areas. Otherwise, death or injury may result.

(1) Make a test solution by dissolving 10 grams of cupric sulfate, Federal Specification O-C-828, in 100 cc of hydrochloric acid, Federal Specification O-C-275.

(2) With a medicine dropper, place one drop of solution on sample to be tested and allow it to remain in contact with metal for two minutes.

(3) At the end of two minutes, slowly add, one drop at a time, three to four drops of water to solution on metal. The copper will not be deposited on metal until water is added.

(4) Wash and dry sample.

NOTE

- If sample is corrosion-resistant steel, the acid cupric sulfate solution will be deposited on metal leaving a copper colored spot. If sample is a nickel-base alloy, a white spot will be left at point where solution came into contact with the metal.
- This test will distinguish only the class of material; however, as a general rule, only stabilized corrosion-resistant steel, AMS 5512, and occasionally nickel chromium iron alloy are used in exhaust stacks and collector rings. Due to various conditions, and several types of corrosion-resistant steels used in structural parts and higher chrome nickel corrosion-resistant steel used in turbosuperchargers, this test can be used as a guide only. A hardness test may also assist in determining condition.

b. *Special Welding Considerations.* Corrosion-resistant (stainless) steels and nickel chromium iron alloy (Inconel) present certain problems in fabrication that are not encountered in more commonly used low carbon and low alloy steels. The 18-8 stabilized corrosion- and heat-resistant steels and nickel chromium iron alloy are quite frequently used for very similar applications. However, there is a great difference in composition and a lesser degree of difference in working of these two materials.

(1) *Nickel chromium iron alloy.* The nickel chromium iron alloy contains approximately 75 percent nickel, 15 percent chromium, 9 percent iron, and 1 percent manganese, and is classed as a nickel-base alloy.

(2) *Corrosion-resistant steels.* 18-8 steels contain approximately 18 percent chromium, 8 percent nickel, and balance iron with small amounts of other elements varying with the particular type of 18-8, and are classed as steels. Welding of any of the corrosion-resistant steels in work-hardened condition shall be accomplished only in specific application as directed in applicable technical manuals.

NOTE

Of the 18-8 series of corrosion-resistant steels, only those types with maximum carbon content of 0.08 percent and unstabilized (type 304) or maximum carbon content of 0.10 and stabilized with titanium or columbium (types 321 and 347 respectively) AMS 5512, corrosion- and heat-resistant, and in annealed condition, have excellent welding qualities. Types 316 and 317, corrosion-resistant steels, although classed with 18-8 series, have higher percentages of nickel, or both nickel and chromium, plus from 2.00 to 4.00 percent molybdenum. These two types are not suitable for welding with the electrodes or gas rods carried under MIL-R-5632. A special electrode, identified as KA2SMO, is provided for welding these types. The balance of this series has only fair to poor weldability.

c. *Corrosion-Resistant Steel Gas Welding.* The following paragraphs describe gas welding practices and procedures.

(1) *Rod selection.* The welding of 18-8 corrosion-resistant steels and nickel chromium iron

alloy by gas welding process shall be accomplished using the following rods:

- Corrosion-resistant steel - steel welding rod, MIL-R-5632, Type II, Grade 3G.
- Nickel chromium iron alloy - nickel chromium iron alloy welding rod, AWS A5.9.

(2) *Flux.* The welding flux to be used in gas welding of these metals is MIL-F-7516. The flux shall be mixed in accordance with instructions on container, or technical grade methanol (wood alcohol), Federal Specification O-M-232, can be mixed with corrosion-resistant flux to form a thin paste. Water will be mixed with nickel chromium iron alloy flux to also form a thin paste. The undersurfaces of joint will be liberally coated with paste and light coating applied to rod. Paste will be used sparingly on top surfaces only when under- surfaces are inaccessible. Under no circumstances shall it be used excessively on top surfaces.

(3) *Tip selection.* The welding tip should be one or two sizes smaller than those used in welding of low carbon steels of the same thickness.

(4) *Flame adjustment.* The welding flame should be slightly reducing with an excess acetylene feather not exceeding 1/16 inch. (See figure 3-4.) In other words, flame should be as near neutral as possible without the possibility of having either an oxidizing or carburizing flame, both of which are detrimental to ductility of metal. A soft flame should be used since a harsh flame, although adjusted to appearance of being neutral, is actually oxidizing.

(5) *Exhaust welding.* When making up a section of an exhaust manifold or similar part, a short flange, 1/32 to 1/16 inch in length, can be formed to the edge or edges and may be left straight to make a butt weld. The joint is then covered with a thin coating of flux and tack welded every two or three inches. On very thin material, it may even be necessary to tack weld at closer intervals. If buckling is encountered during tacking operation, part shall be reshaped before proceeding with welding operation. Prior to welding operation, seam shall be refluxed in accordance with instructions contained in paragraph (2).

NOTE

The procedures outlined in paragraphs (1) through (5) are to be followed in both tacking and welding seams. Under no circumstances will corrosion-resistant steel or nickel chromium iron alloy aircraft parts be welded by gas process without use of flux of proper grade.

d. *Corrosion-Resistant Steel Arc Welding.* The following paragraphs describe arc welding practices and procedures.

(1) *Electrode selection.* The welding of 18-8 corrosion-resistant steels, and nickel chromium iron alloy, by the metallic arc welding process, will be accomplished using the following electrodes:

- Corrosion-resistant steel- electrode, corrosion-resistant steel, MIL-R-5632, Type I, Grade 3E.
- Nickel chromium iron alloy-nickel chromium iron alloy welding, AWS A5.9, rod (electrode).

(2) *Arc length.* To obtain maximum efficiency of flux in protecting the molten metal, short arc, approximately the same length or shorter than diameter of electrode being used, is a definite requirement. These electrodes have a heavy coating of flux which helps to prevent oxidation of the weld metal in its passage through the arc. Satisfactory welds cannot be made with a long arc.

(3) *Polarity.* Corrosion-resistant and nickel chromium iron alloy electrodes are generally used with straight polarity on very thin material to prevent burn through. Due to many variables in welding machines, arc characteristics, inaccuracy of voltmeters and ammeters, differences in individual welder ability, and type of weld joint, exact welding currents will not be recommended. For successful corrosion-resistant steel and nickel chromium iron alloy welding, the best rule to follow is to use least possible current consistent with proper fusion. The values established in table 3-7 should be used only as a guide in adjusting welding current.

TM 1-1500-204-23-8

(4) *Arc welding procedures.* The following procedures will produce welds of good quality:

(a) Grind tungsten electrode to an approximate 60-degree point (included angle).

(b) Do not attempt to strike an arc in a molten (weld) pool.

(c) Regrind electrode if arc is accidentally struck in molten pool.

(d) Use gas welding flux, MIL-F-7516, as applicable, sparingly on underside of weld area when necessary to control oxidation.

(e) Use only gas welding rods as applicable or as specified in paragraph (a).

NOTE

Maximum length of electrode protruding from gas cup should not exceed 1/4 inch.

(f) Adhere closely to amperage, voltage, gas flow and electrode size as specified in table 3-8.

(5) *Inert-arc welding.* A comparatively recent development in arc welding, which is referred to as inert-arc, has earned wide recognition in the field of corrosion-resistant steel and nickel alloy welding, particularly as applied to thin sheet, 0.050-inch thickness and under. The use of this process in fabrication of thin sections produces welds having very good strength and ductility. This type of welding was originally applied to magnesium, with helium gas as the shielding medium. Although helium may also be used in welding of steels and nickel alloy in heavier sections, argon gas is preferred on thin sections due to difficulties encountered in establishing the arc with low current setting when using helium. A lower arc voltage is required to establish and maintain the arc with use of argon. The arc in argon envelope has the appearance of a gas welding flame, whereas helium produces a blunt or ball-like flame. Direct current with straight polarity is used in welding steels and nickel alloys by this process. The arc welder used with this special equipment should conform to MIL-W-80019.

e. *Corrosion-Resistant Steel Spot Welding.* Spot welding may be used on low carbon steels, austenitic steels, hardenable steels, and nickel alloys. The following paragraphs describe spot welding practices and procedures.

WARNING

Drycleaning solvent is flammable, and solvent vapors are toxic. Use P-D-680, Type II Solvent in a well-ventilated area. Keep away from open flames. Avoid prolonged solvent contact with skin.

(1) *Cleaning.* Clean surfaces to be welded of objectionable films, such as oxides, scales, ink, grease, or dust, using a clean rag or bristle brush moistened with drycleaning solvent, Federal Specification P-D-680.

(2) *Spot spacing.* The edge distance will be so that no deformation or bulge will occur at edge of sheet.

(3) *Surface indentation.* Where aerodynamic consideration is a requisite, the electrode indentation shall not exceed 0.003 inch. In all other cases, indentation is not acceptable when depth exceeds 10 percent of sheet thickness.

(4) *Defects.* Weld defects such as voids, blow holes, porosity, and cracks shall not exceed the following limits:

- 15 percent of area of the weld nugget in the plane in which the measurement is taken, or a linear dimension greater than 25 percent of the weld diameter.
- No internal defect shall extend to within 15 percent of weld diameter of the boundaries of the case weld structure.

(a) *Welding Stresses and Distortion.* In welding of corrosion-resistant steels or nickel chromium iron alloy, care must be taken to avoid welding stresses and distortion as much as possible. In making joints, sheets should be spread slightly apart and tack welded. The amount of spread will depend on whether arc or gas welding is employed, less spread being required with arc than with gas welding. For this reason, and the fact that there is less tendency toward carbide precipitation in welding of corrosion-resistant steels with use of the former, the arc process is recommended. The arc process is particularly recommended on applications where it is impossible to allow for expansion and contraction of material. The distribution of contraction stresses can be further improved by using back step welding in which electrode is advance a short distance ahead of weld and joint is welded back toward original starting point.—This process is repeated until weld is completed. When practicable, jigs shall be used to hold

Table 3-7. Relation Between Sheet Thickness and Current Required for Metallic Arc Welding of Corrosion-Resistant Steels and Nickel Alloys

Thickness of sheet (inches)	Diameter of electrode (inches)	Approximate welding current (amperes)
0.031	5/64	30
0.0375	5/64	35
0.0438	5/64	40
0.050	3/32	50
0.062	3/32	55
0.080	3/32	60
0.093	3/32	65
0.125	1/8	75
0.187	1/8	90
0.250	5/32	100

Table 3-8. Relation Between Sheet Thickness and Current Required for Inert-Arc Welding of Corrosion-Resistant Steels and Nickel-Base Alloys

Thickness of sheet (inches)	Diameter of electrode (inches)	Approximate welding current (amperes)	Argon flow per ¹ minute
0.010	0.040	10-13	3 liters
0.015	0.040	13-16	3 liters
0.020	0.040	16-20	3 liters
0.025	0.040	20-23	4 liters
0.031	1/16	23-26	4 liters
0.037	1/16	26-29	4 liters
0.043	1/16	29-32	4 liters
0.050	1/16	32-35	4 liters

NOTE

The welding voltage should be approximately 15.

¹These figures based on calibration for oxygen flow.

joint in alignment and to limit buckling. The metal in the jig also helps to dissipate heat and to reduce contraction stresses.

3-8. Welding on Aircraft. Welding will not be accomplished on operational aircraft until the following precautions have been observed:

- Place a fire extinguisher in immediate area and

observe all fire precautions.

- Isolate area to be welded from all parts or members which might be injured by contact with heat.
- Insulate area to be welded using fire retardent materials to prevent heat distortion or damage to adjacent parts.

TM 1-1500-204-23-8

3-9. Brazing and Silver Soldering. Brazing and silver soldering are methods of joining metals where strength is not important. In either process, a low melting point alloy is used to sweat or bond metal together without fusing the base metal. The term brazing is generally understood to mean the joining of metals with a film of brass, while silver soldering indicates that a silver alloy is the medium.

a. Brazing Brazing may be used to join copper, high melting point brass, bronze, Monel metal, plain carbon steels, and some alloy steels.

(1) *Brazing mixture.* For metals having a melting point of 1750°F (935°C) or more, use a mixture of alloy of copper, tin, and zinc which has a melting point of 1625°F (884°C). For copper and low melting point brasses, use an alloy of 50 percent copper and 50 percent brass. This alloy has a melting point of 1560°F (848°C), and is used in a granulated form, referred to as brazing spelter.

NOTE

When the parts require heat-treating, an alloy of 80 percent copper and 20 percent zinc should be used. This mixture has a melting point of 1832°F (999°C).

(2) *Cleaning.* Clean joint to be brazed to a bright surface using a hot 10 percent solution of sodium hydroxide, Federal Specification A-A-895, followed by a hot water rinse. Sand blast should be used for removal of oxide and scale.

NOTE

When the sand blast is not available, a grinding wheel, wire buff, or a file may be used.

(3) *Blow pipe brazing.* Use oxyacetylene or Bunsen burner flame for blow pipe brazing. The following guidelines must be observed while blow pipe brazing.

(a) *Flame adjustment.* The flame should be neutral and outer flame envelope used to supply heat. The tip of central cone should be held 1/4 to 3/8 inch from metal surface at joint.

(b) *Application of flux.* Apply flux by either dipping hot end in dry powder, or by coating rod with a flux solution.

(c) *Heat joint.* The joint should be brought to a full red heat so that flux will melt and flow when applied.

(d) *Brazing metal.* Add sufficient brazing metal to sweat through joint.

CAUTION

Care must be taken to prevent overheating either the base metal or brazing metal. Blue vapor is an indication of excess temperature. Damage to component may otherwise result.

(4) *Furnace brazing.* Accomplish this method of brazing by setting up work with both flux and brazing metal placed in the furnace, then adjust temperature to a point where brazing material will melt and adhere to the metal.

b. Silver Soldering Silver soldering may be used for joining copper and its alloys, Monel metal, nickel, and silver. It may also be used for joining thin steel parts.

(1) *Solder.* General purpose silver solder is procured under Federal Specification QQ-B-654, Grade 4.

(2) *Flux.* When prepared flux is not available, use a mixture of 12 parts of sodium borate (borax), Military Specification ASTM-D-929, and 1 part of boric acid, Federal Specification O-C-265. The flux must melt at a slightly lower temperature than solder. When flux begins to flow, the solder should be added.

(3) *Cleaning.* Clean dirt, grease, oil, oxide, and paint from metal to be soldered.

(4) *Flame adjustment.* Use oxyacetylene flame in the following manner for soldering:

- Adjust flame to a neutral or a very slight excess of acetylene.
- The tip of central cone should be held about 1/2 inch from work and kept in motion to avoid overheating.

(5) *Application of solder.* After preheating both parts to an equal temperature, apply solder to surface of under or inner part at edge of seam, while the flame

is directly over entire seam and kept in order to maintain an even temperature.

c. *Post Brazing and Silver Soldering.* Clean brazed or soldered joint of flux using the following procedures:

WARNING

Hydrochloric acid is highly toxic and corrosive. Goggles, rubber gloves, and rubber aprons should be worn when handling the acid and the acid solution. Do not inhale gases and mists. When spilled on the body or clothing, wash immediately with large quantities of cold water, and seek medical help. Do not pour water into acid when preparing the solution; instead, pour acid into water. Always mix acid and water slowly. Perform cleaning operations only in well-ventilated areas. Otherwise, death or injury may result.

(1) Remove flux from nonferrous metals by treating with a solution of one ounce of sulfuric acid, Federal Specification O-S-809, and 1.5 ounces of sodium bichromate, Federal Specification O-S-595, added to one gallon of water.

(2) Remove flux from ferrous metals by boiling for 30 minutes in a 10 to 15 percent solution of caustic soda, Federal Specification O-C-275.

(3) Follow either treatment with a thorough rinse in clean water.

(4) Remove discoloration caused by immersing the part in a solution of 68 ounces of sulfuric acid, Federal Specification O-S-809; 20 ounces of nitric acid, Federal Specification O-N-350; 1 ounce of hydrochloric acid, Federal Specification O-H-765; and 40 ounces of water. Rinse in clean running water.

APPENDIX A

REFERENCES

A-1. ARMY REGULATIONS (AR):

AR 385-10 Army Safety Program

A-2. LEGAL AND CONSENSUS STANDARDS:

OSHA 1910.251 Welding, Cutting, and Brazing

NFPA 410 Aircraft Maintenance

A-3. REFERENCE BOOKS:

NSN 7610-00-059-6718 New American Machinists' Handbook

How To Run a Lathe; South Bend Lathe
Works, South Bend, Indiana

Principles of Industrial Welding;
Lincoln Electric Co., Cleveland, Ohio

Principles Handbook of Arc Welding;
Lincoln Electric Co., Cleveland, Ohio

Shop Theory; Henry Ford Trade School,
McGraw Hill, New York, N.Y.

A-4. TECHNICAL MANUALS (TM):

TM 9-237 Operator's Manual for Welding Theory and Application

A-5. AWS American Welding Society

GLOSSARY

ACETYLENE -	A highly combustible gas compound of carbon and hydrogen.
ALLOY-	A mixture, with metallic properties, composed of two or more elements of which at least one is a metal.
ARC WELDING -	A group of welding processes in which fusion is obtained by heating with an electric arc or arcs, with or without the use of filler metal.
BRAZING -	A group of welding processes in which a groove, fillet, lap, or flange is bonded by using a nonferrous filler metal having a melting point above 800° F (427° C) but below that of the base metals. Filler metal is distributed in the joint by capillary attraction.
BUCKLING -	Distortion caused by the heat of a welding process.
CARBURIZING FLAME -	An oxyacetylene flame in which there is an excess of acetylene. Also called excess acetylene or reducing flame.
FLASHBACK-	The burning of gases within the torch or beyond the torch in the hose, usually with a shrill, hissing sound.
FLUX -	A cleaning agent used to dissolve oxides, release trapped gases and slag, and to cleanse metals for welding, soldering, and brazing.
FUSION -	A thorough and complete mixing between the two edges of the base metal to be joined or between the base metal and the filler metal added during welding.
GAS WELDING -	A process in which the welding heat is obtained from a gas flame.
JOINT-	That portion of a structure in which separate base parts are joined.
NEUTRAL FLAME -	A gas flame in which the oxygen and acetylene volumes are balanced and both gases are completely burned.
OXIDIZING FLAME -	An oxyacetylene flame in which there is an excess of oxygen. The unburned excess tends to oxidize the weld metal.
OXYACETYLENE WELDING -	A welding process in which the required temperature is attained by flames obtained from the combustion of acetylene with oxygen.
REVERSE POLARITY -	The arrangement of direct current arc welding leads in which the work is the negative pole and the electrode is the positive pole of the welding arc.

GLOSSARY- CONT

SPOT WELDING -	A resistance welding process in which fusion is produced by the heat obtained from the resistance to the flow of electric current through the workpieces held together under pressure by electrodes. The size and shape of the individually formed welds are; limited by the size and contour of the electrodes.
STRAIGHT POLARITY -	The arrangement of direct current arc-welding leads where the work is the positive pole and the electrode is the negative pole of the welding arc.
TACK WELD -	A weld made to hold parts of a weldment in proper alignment until the final welds are made.
WELD -	A localized fusion of metals produced by heating to suitable temperatures. Pressure and/or filler metal may or may not be used. The filler metal has a melting point approximately the same or below that of the base metals, but always above 800° F (427° C).

INDEX

Subject	Paragraph, Figure, Table Number
A	
Aluminum Alloys, Typical Machine Setting for Spot Welding.....	T3-4
Aluminum Arc Welding	3-5d
Aluminum Gas Welding	3-5c
Aluminum Spot Welding.....	3-5e
Aluminum Welding.....	3-5
Arc Welding.....	3-5d
Cleaning.....	3-5b
Gas Welding.....	3-5c
Spot Welding.....	3-5e
Types of Alloys.....	3-5a
Arc Welding Defects, Causes, and Remedies	T3-3
Arc Welding Magnesium	T3-6
B	
Bandsaws	
Care and Use	2-4b
Cutoff-Type	F2-3
Vertical-Contour Type.....	F2-2
Bearing Roll Staking	2-6e
Brazing	3-9a
Brazing and Silver Soldering	3-9
Brazing	3-9a
Post Brazing and Silver Soldering Cleaning	3-9c
Silver Soldering	3-9b
Brush Method of Starting Electric Arc.....	F3-5
C	
Care and Use of Equipment	2-4
Bandsaws	2-4b
Drilling Machines	2-4a
Grinders	2-4f
Lathes	2-4c
Milling Machines.....	2-4d
Shapers.....	2-4e
Cleaning	
Aluminum Welding.....	3-5b
Magnesium Welding	3-6a
Consumable Materials	1-3
Corrosion-Resistant Steel and Nickel Chromium Alloy Welding	3-7
Arc Welding	3-7d
Distinguishing Corrosion-Resistant Steels and Nickel-Base Alloys	3-7a
Gas Welding	3-7c
Special Welding Considerations	3-7b
Spot Welding.....	3-7e

INDEX-CONT

Subject	Paragraph, Figure, Table Number
C - Continued	
Welding Stresses and Distortion	3-7f
Corrosion-Resistant Steel Arc Welding.....	3-7d
Corrosion-Resistant Steel Gas Welding.....	3-7c
Corrosion-Resistant Steel Spot Welding.....	3-7e
Corrosion-Resistant Steels and Nickel Alloys, Relation Between Sheet Thickness and Current Required for Metallic Arc Welding of.....	T3-8
Corrosion-Resistant Steels and Nickel-Base Alloys, Relation Between Sheet Thickness and Current Required for Inert-Arc Welding of	T3-9
Counterboring and Spotfacing	2-6c
Cut-off Type Bandsaw.....	F2-3
D	
Distinguishing Corrosion-Resistant Steels and Nickel-Base Alloys.....	3-7a
Drill Press	F2-1
Drilling Machines	
Care and Use	2-4a
Safety Precautions	2-3a
Special Operations on	2-6
E	
Electric Arc Welding.....	3-3b
Electric Arc Welding Equipment.....	F3-2
Electrodes.....	3-4a ,T3-1
Equipment Safety.....	2-2c
F	
Fire Safety	2-2d
Flames, Gas Welding.....	F3-4
Fluxes	3-4c
G	
Gas Welding	3-3a
Gas Welding Equipment	F3-1
Gas Welding Equipment, Guide to Regulation of	T3-5
Gas Welding Flames.....	F3-4
General	
Machine Shop Practices	2-1
Welding Shop Practices.....	3-1
General Layout Practices	2-5a

INDEX-CONT

Subject	Paragraph, Figure, Table Number
---------	---------------------------------------

G - Continued

Grinder	F2-7
Grinder Wheel	F2-8
Grinding Machines	
Care and Use	2-4f
Safety Precautions	2-3b
Wheel Installation	F2-8
Guide to Regulation of Gas Welding Equipment	T3-5

I

Inert-Arc Welding of Corrosion-Resistant Steels and Nickel- Base Alloys, Relation Between Sheet Thickness and Current Required for	T3-9
Introduction	
Consumable Materials	1-3
Purpose	1-1
Scope	1-2

L

Lapping	2-6d
Lathes	F2-4
Care and Use	2-4c
Safety Precautions	2-3c
Laying Out and Mounting Work	2-5
General Layout Practices	2-5a
Mounting	2-5b

M

Machine Safety Precautions	2-3
Drilling Machines	2-3a
Grinding Machines	2-3b
Lathes	2-3c
Milling Machines	2-3d
Miscellaneous Machine Tools	2-3f
Portable Machine Tools	2-3g
Shapers and Planers	2-3e
Machine Settings for Arc Welding Magnesium	T3-6
Machine Shop Practices	
Care and Use of Equipment	2-4
General	2-1
Laying Out and Mounting Work	2-5
Machine Safety Precautions	2-3
Shop Rules	2-2
Special Operations on Drilling Machines	2-6
Magnesium Arc Welding	3-6c

INDEX - CONT

Subject	Paragraph, Figure, Table Number
---------	---------------------------------------

M - Continued

Magnesium Gas Welding	3-6b
Magnesium Spot Welding	3-6d
Magnesium Welding	3-6
Arc Welding	3-6c
Cleaning	3-6a
Gas Welding	3-6b
Spot Welding	3-6d
Metallic Arc Welding of Corrosion-Resistant Steels and Nickel Alloys, Relation Between Sheet Thickness and Current Required for	T3-8
Milling Machines	
Care and Use	2-4d
Safety Precautions	2-3d
Miscellaneous Machine Tools, Safety Precautions	2-3f
Mounting Work	2-5b

P

Portable Machine Tools, Safety Precautions	2-3g
Post Brazing and Silver Soldering Cleaning	3-9c
Purpose of Manual	1-1

R

Reaming	2-6a
Relation Between Sheet Thickness and Current Required for Inert-Arc Welding of Corrosion-Resistant Steels and Nickel-Base Alloys	T3-9
Relation Between Sheet Thickness and Current Required for Metallic Arc Welding of Corrosion-Resistant Steels and Nickel Alloys	T3-8
Responsibility	
Machine Shop Rules, for	2-2a
Welding Shop Rules, for	3-2a
Rod Information, Welding So	T3-2

S

Safety, Welding Shop	3-2c
Schematic, Welding Equipment	F3-3
Scope of Manual	1-2
Shaper	F2-6
Shapers and Planers, Safety Precautions	2-3e
Shapers, Care and Use	2-4e
Shop Housekeeping	
Machine Shop	2-2b
Welding Shop	3-2b

INDEX - CONT

Subject	Paragraph, Figure, Table Number
---------	---------------------------------------

S - Continued

Shop Rules, Machine Shop	2-2
Equipment Safety	2-2c
Fire Safety	2-2d
Responsibility	2-2a
Shop Housekeeping	2-2b
Shop Rules, Welding Shop	3-2
Responsibility	3-2a
Safety	3-2c
Shop Housekeeping	3-2b
Silver Soldering	3-9b
Special Operations on Drilling Machines	2-6
Bear Roll Staking	2-6e
Counterboring and Spotfacing	2-6c
Lapping	2-6d
Reaming	2-6b
Tapping	2-6a
Special Welding Considerations, Corrosion-Resistant Steel and Nickel Chromium Alloy Welding	3-7b
Starting Electric Arc, Brush Method	F3-5
Stress Relieving Treatment	T3-7

T

Tapping	2-6a
Treatment, Stress Relieving	T3-7
Types of Alloys, Aluminum	3-5a
Types of Welding	3-3
Electric Arc Welding	3-3b
Gas Welding	3-3a
Spot Welding	3-3c
Typical Machine Setting for Spot Welding Aluminum Alloys	3-4

V

Vertical-Contour Bandsaw	F2-2
--------------------------------	------

W

Welding Equipment.	
Electric Arc	F3-2
Gas	F3-1
Schematic	F3-3
Welding, Arc; Defects; Causes, and Remedies	T3-3
Welding Materials	3-4
Electrodes	3-4a
Fluxes	3-4c

INDEX - CONT

Subject	Paragraph, Figure, Table Number
W - Continued	
Welding Rods	3-4b
Welding on Aircraft	3-8
Welding Rod Information	T3-2
Welding Rods	3-4b
Welding Shop Practices	
Aluminum Welding	3-5
Brazing and Silver Soldering	3-9
Corrosion-Resistant Steel and Nickel Chromium Alloy Welding	3-7
General	3-1
Magnesium Welding	3-6
Shop Rules	3-2
Types of Welding	3-3
Welding Materials	3-4
Welding on Aircraft	3-8
Welding Stresses and Distortion, Corrosion-Resistant Steels and Nickel Chromium Alloy Welding	3-7f

By Order of the Secretary of the Army:

GORDON R. SULLIVAN
General, United States Army
Chief of Staff

Official:

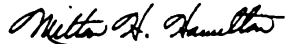

MILTON H. HAMILTON
Administrative Assistant to the
Secretary of the Army
02550

Distribution:

To be distributed in accordance with DA Form 12-31-E, block no. 3226, requirements for TM 1-1500-204-23-8.

RECOMMENDED CHANGES TO EQUIPMENT TECHNICAL PUBLICATIONS

 <p style="font-size: small; margin: 0;"><i>THEN...JOT DOWN THE DOPE ABOUT IT ON THIS FORM. CAREFULLY TEAR IT OUT, FOLD IT AND DROP IT IN THE MAIL.</i></p>		SOMETHING WRONG WITH PUBLICATION	
		FROM: (PRINT YOUR UNIT'S COMPLETE ADDRESS)	
		DATE SENT	
PUBLICATION NUMBER		PUBLICATION DATE	PUBLICATION TITLE
BE EXACT PIN-POINT WHERE IT IS			
PAGE NO.	PARA-GRAPH	FIGURE NO.	TABLE NO.
IN THIS SPACE, TELL WHAT IS WRONG AND WHAT SHOULD BE DONE ABOUT IT.			
PRINTED NAME, GRADE OR TITLE AND TELEPHONE NUMBER			SIGN HERE

The Metric System and Equivalents

Linear Measure

1 centimeter = 10 millimeters = .39 inch
 1 decimeter = 10 centimeters = 3.94 inches
 1 meter = 10 decimeters = 39.37 inches
 1 dekameter = 10 meters = 32.8 feet
 1 hectometer = 10 dekameters = 328.08 feet
 1 kilometer = 10 hectometers = 3,280.8 feet

Weights

1 centigram = 10 milligrams = .15 grain
 1 decigram = 10 centigrams = 1.54 grains
 1 gram = 10 decigrams = .035 ounce
 1 decagram = 10 grams = .35 ounce
 1 hectogram = 10 decagrams = 3.52 ounces
 1 kilogram = 10 hectograms = 2.2 pounds
 1 quintal = 100 kilograms = 220.46 pounds
 1 metric ton = 10 quintals = 1.1 short tons

Liquid Measure

1 centiliter = 10 milliliters = .34 fl. ounce
 1 deciliter = 10 centiliters = 3.38 fl. ounces
 1 liter = 10 deciliters = 33.81 fl. ounces
 1 dekaliter = 10 liters = 2.64 gallons
 1 hectoliter = 10 dekaliters = 26.42 gallons
 1 kiloliter = 10 hectoliters = 264.18 gallons

Square Measure

1 sq. centimeter = 100 sq. millimeters = .155 sq. inch
 1 sq. decimeter = 100 sq. centimeters = 15.5 sq. inches
 1 sq. meter (centare) = 100 sq. decimeters = 10.76 sq. feet
 1 sq. dekameter (are) = 100 sq. meters = 1,076.4 sq. feet
 1 sq. hectometer (hectare) = 100 sq. dekameters = 2.47 acres
 1 sq. kilometer = 100 sq. hectometers = .386 sq. mile

Cubic Measure

1 cu. centimeter = 1000 cu. millimeters = .06 cu. inch
 1 cu. decimeter = 1000 cu. centimeters = 61.02 cu. inches
 1 cu. meter = 1000 cu. decimeters = 35.31 cu. feet

Approximate Conversion Factors

To change	To	Multiply by	To change	To	Multiply by
inches	centimeters	2.540	ounce-inches	Newton-meters	.007062
feet	meters	.305	centimeters	inches	.394
yards	meters	.914	meters	feet	3.280
miles	kilometers	1.609	meters	yards	1.094
square inches	square centimeters	6.451	kilometers	miles	.621
square feet	square meters	.093	square centimeters	square inches	.155
square yards	square meters	.836	square meters	square feet	10.764
square miles	square kilometers	2.590	square meters	square yards	1.196
acres	square hectometers	.405	square kilometers	square miles	.386
cubic feet	cubic meters	.028	square hectometers	acres	2.471
cubic yards	cubic meters	.765	cubic meters	cubic feet	35.315
fluid ounces	milliliters	29.573	cubic meters	cubic yards	1.308
pints	liters	.473	milliliters	fluid ounces	.034
quarts	liters	.946	liters	pints	2.113
gallons	liters	3.785	liters	quarts	1.057
ounces	grams	28.349	liters	gallons	.264
pounds	kilograms	.454	grams	ounces	.035
short tons	metric tons	.907	kilograms	pounds	2.205
pound-feet	Newton-meters	1.356	metric tons	short tons	1.102
pound-inches	Newton-meters	.11296			

Temperature (Exact)

° F	Fahrenheit temperature	5/9 (after subtracting 32)	Celsius temperature	° C
-----	------------------------	----------------------------	---------------------	-----

