

FM 1-06
(14-100)

FINANCIAL MANAGEMENT OPERATIONS

SEPTEMBER 2006

DISTRIBUTION RESTRICTION: Distribution for public release;
distribution is unlimited.

**HEADQUARTERS
DEPARTMENT OF THE ARMY**

This publication is available at
Army Knowledge Online (www.us.army.mil) and
General Dennis J. Reimer Training and Doctrine
Digital Library at (www.train.army.mil).

***FM 1-06 (FM 14-100)**

Field Manual
No. 1-06 (14-100)

Headquarters
Department of the Army
Washington, DC, 21 September 2006

Financial Management Operations

Contents

	Page
PREFACE	v
INTRODUCTION.....	vi
Chapter 1 FINANCIAL MANAGEMENT.....	1-1
SECTION I –FINANCE OPERATIONS.....	1-2
ARMY FORCE GENERATION (ARFORGEN).....	1-2
PRE-DEPLOYMENT AND MOBILIZATION OPERATIONS	1-3
DEPLOYMENT AND FULL SPECTRUM OPERATIONS	1-4
STABILITY OPERATIONS	1-9
REDEPLOYMENT AND DEMOBILIZATION OPERATIONS.....	1-9
SECTION II – RESOURCE MANAGEMENT OPERATIONS.....	1-10
LEVELS AND EMPHASIS OF PLANNING, PROGRAMMING, BUDGETING, AND EXECUTION	1-12
ESSENTIAL ELEMENTS OF RESOURCE MANAGEMENT OPERATIONS..	1-14
CONTINGENCY OPERATIONS	1-22
LOGISTICS CIVIL AUGMENTATION PROGRAM (LOGCAP).....	1-26
SECTION III - FINANCIAL MANAGEMENT IN JOINT, INTERAGENCY, INTERGOVERNMENTAL, AND MULTINATIONAL OPERATIONS (JIIM)....	1-27
PROVIDE FINANCIAL MANAGEMENT GUIDANCE AND RECOMMENDATIONS	1-28
SUPPORT THE PROCUREMENT PROCESS.....	1-28
PROVIDE LIMITED PAY SUPPORT	1-28
NONCOMBATANT EVACUATION OPERATIONS (NEO)	1-28
JOINT OPERATIONS AND CONTINGENCY OPERATIONS FUND ACQUISITION	1-29
HUMANITARIAN ASSISTANCE AND DISASTER RELIEF	1-29
NATION ASSISTANCE	1-29
PEACE OPERATIONS.....	1-30

Distribution Restriction: Approved for public release; distribution is unlimited.

*This publication supersedes FM 14-100, 7 May 1997.

Contents

Chapter 2	FINANCIAL MANAGEMENT ORGANIZATIONAL STRUCTURE, ROLES, AND RESPONSIBILITIES	2-1
	SECTION I –COMMAND AND CONTROL	2-1
	STRATEGIC FINANCIAL MANAGEMENT.....	2-1
	OPERATIONAL FINANCIAL MANAGEMENT.....	2-2
	TACTICAL FINANCIAL MANAGEMENT.....	2-2
	SECTION II – COMMAND AND CONTROL RELATIONSHIPS	2-3
	FINANCIAL MANAGEMENT CONCEPT OF SUPPORT – ASCC.....	2-3
	FINANCIAL MANAGEMENT CONCEPT OF SUPPORT – CORPS AND/OR DIVISION.....	2-12
Chapter 3	INFORMATION MANAGEMENT	3-1
	FINANCIAL MANAGEMENT TACTICAL PLATFORM CAPABILITIES AND CHARACTERISTICS.....	3-1
	COMMUNICATIONS.....	3-3
Appendix A	Legal	A-1
Appendix B	Financial Management Deployment Checklist	B-1
Appendix C	Guide to Operation Plan Development	C-1
Appendix D	Paying Agents	D-1
Appendix E	Fiscal Appropriations, Authorities, and Agreements	E-1
Appendix F	Financial Support to Military Operations in a Multinational Environment ..	F-1
Appendix G	Financial Management Support to Theater Support Contracting	G-1
Appendix H	Obligation Management	H-1
Appendix I	Management Control Program	I-1
Appendix J	Destruction of Currency	J-1
Appendix K	Cashing Personal Checks During Deployments	K-1
Appendix L	Foreign Currency Conversions and Reconversions	L-1
Appendix M	Casual Payments Using DD Form 1351-6	M-1
Appendix N	Precertified Payment Processing Using SF 1034	N-1
Appendix O	Solatium Payments	O-1
Appendix P	Rewards Programs	P-1
Appendix Q	Travel (Temporary Duty) Payments Using DD Form 1351-6	Q-1
Appendix R	DD Form 1081	R-1
Appendix S	Processing of Enemy Prisoners of War and Civilian Internees and Captured Currency	S-1
Appendix T	Strategic Reimbursement Procedures	T-1
	GLOSSARY	Glossary-1
	REFERENCES	References-1
	INDEX	Index-1

Figures

Figure I-1. The levels of FM.....	vii
Figure I-2. Fiscal Triad.....	viii
Figure 1-1. Flow of Appropriated Funds.....	1-17
Figure 1-2. Funding Authorization Document (FAD) Flow	1-18
Figure 1-3. Examples of Incremental Costs	1-24
Figure 1-4. Examples of Non-chargeable Costs	1-25
Figure 1-5. Example of Joint Manning Document (JMD)	1-27
Figure 2.1. Financial Management Levels of Support.....	2-3
Figure 2-2. ASCC G8 Organizational Structure	2-4
Figure 2-3. Financial Management Center (FMC) Organizational Structure	2-8
Figure 2-4. Financial Management Company (FM CO) Organizational Structure.....	2-10
Figure 2-5. Financial Management Detachment (FM DET) Organizational Structure ..	2-15
Figure 3-1. Financial Management Tactical Platform (FMTP)	3-2
Figure 3-2. Financial Management Unit Communications	3-3
Figure 3-3. Financial Management Communications Networks	3-6
Figure D-1. Sample Appointment Order.....	D-2
Figure D-2. Sample SF 44.....	D-5
Figure H-1. Sample of Completed DD Form 448	H-16
Figure H-2. Sample of Completed DD Form 448-2.....	H-19
Figure H-3. Sample Memorandum of Agreement	H-21
Figure H-4. Sample of Completed SF 1080	H-22
Figure H-5. Sample of Completed DD Form 1610 Prepared for an Individual (Front) ..	H-24
Figure H-6. Sample of Completed DD Form 1610 Prepared for an Individual (Back) ..	H-25
Figure H-7. Sample of Completed DA Form 3953 (Page 1)	H-29
Figure H-8. Sample of Completed DA Form 3953 (Page 2)	H-30
Figure H-9. Sample of Completed DD Form 1155	H-33
Figure H-10. Sample of a Completed DD Form 2406 (Front)	H-36
Figure H-11. Sample of a Completed DD Form 2406 (Reverse).....	H-37
Figure H-12. Fiscal Code/Accounting Classification	H-38
Figure O-1. Sample Solatium Payment Witness Statement	O-3
Figure P-1. Sample of Completed DA Form 4137 (Front)	P-3
Figure P-2. Sample of Completed DA Form 4137 (Back).....	P-4

Tables

Table 1-1. Processing a Transaction	1-19
Table D-1. Instructions for Completing SF 44	D-4
Table H-1. Basis for Recording Obligations	H-7

Contents

Table H-2. Obligations for Intra-Government Agreements	H-9
Table H-3. Obligations for Civilian Personnel Services, Incentive Awards, and Severance Pay	H-10
Table H-4. Obligations for Travel and Transportation	H-11
Table H-5. Miscellaneous Rules	H-11
Table H-6. Obligations for Adjustments	H-13
Table H-7. Instructions for Completing DD Form 448, Military Interdepartmental Purchase Request	H-17
Table H-8. Instructions for Completing DD Form 448-2, Acceptance of MIPR	H-20
Table H-9. Instructions for Completing SF 1080.....	H-23
Table H-10. Instructions for Completing DD Form 1610	H-26
Table H-11. Instructions for Completing DA Form 3953, Purchase Request and Commitment	H-31
Table H-12. Instructions for Completing DD Form 1155, Order for Supplies or Services	H-34
Table H-13. Standard Accounting Classification Data Elements	H-38
Table H-14. Accounting Classification—Example 1	H-39
Table H-15. Accounting Classification—Example 2	H-40
Table I-1. Summary of Comptroller General Standards for Management Controls	I-1

Preface

This manual serves as Financial Management's keystone doctrine. The term "financial management (FM)" in this manual refers to both finance and resource management (RM) responsibilities. This manual provides the foundation of FM doctrine, organizations, training, materiel, leadership and education, personnel, and facilities (DOTMLPF) development to support the modular Army.

The purpose of this manual is to provide the authoritative doctrine on how the Army's FM system supports the full spectrum of operations as part of the national-theater sustainment provider. The fundamental purpose of the Army is to provide joint force commanders with sustained and decisive land forces necessary to fight and win the nation's wars. Focused FM support that is responsive, flexible, and precise is crucial to the Army's ability to rapidly project power with the most capable forces at the decisive time and place. In order to support full spectrum operations, FM must provide support during all operational phases.

Financial management maximizes the capabilities of the Army by being responsive to the commander's needs for agility, deployability, lethality, versatility, survivability, and sustainability. This manual discusses how FM operations can extend the operational reach of combat forces by maximizing technology and minimizing the sustainment footprint. The manual recognizes that FM is provided by active and reserve component, Department of Defense and Department of the Army civilian, joint, and multinational assets. This manual also recognizes that FM, like the other warfighting functions, is a commander's combat multiplier. Therefore, FM support is involved throughout the entire military decisionmaking process. It is managed, executed, and assessed through all stages to enable commanders to execute and sustain full spectrum operations over time, as well as to extend the operational reach of the force.

The intended audiences for the manual are: (1) commanders at all levels, to provide a universal understanding of how FM is organized and functions to support Army, joint, interagency, intergovernmental, and multinational (JIIM) forces; (2) sustainment community, staffs, and doctrinal proponents, to institutionalize the integration of FM into all Army components, and JIIM missions; and (3) Soldiers at all levels and within all branches of the Army, to provide a broad knowledge of the FM structure and functions. Army headquarters serving as a joint force land component command or a joint task force headquarters should also refer to ***JP 1-06, Joint Tactics, Techniques, and Procedures for Financial Management During Joint Operations***.

This publication applies to the Active Army, the Army National Guard/Army National Guard of the United States, and United States Army Reserve unless otherwise stated.

The proponent for this manual is the U.S. Army Training and Doctrine Command (TRADOC). Send comments and recommendations to fmdoctrine@jackson.army.mil or on DA Form 2028 (Recommended Changes to Publications and Blank Forms) to Commandant, U.S. Army Finance School, ATTN: ATSG-FSP-C, Building 10000, Fort Jackson, SC 29207-7045.

Unless stated otherwise, masculine nouns or pronouns do not refer exclusively to men.

Introduction

Financial management support is both tailorable and scalable in its ability to rapidly task-organize an independent force for a specific mission. It is sufficiently modular to conduct independent non-contiguous operations, and is able to aggregate into a campaign quality force. FM operations are directly related to the Joint Campaign phases and are directly linked to the strategic, operational, and tactical levels (figure I-1). Each phase contains multiple tasks that are distributed among resource management and finance activities. Chapter 2 provides the details to each task and provides the linkage to the phase and level. This task linkage provides critical synchronization between RM, finance, and contracting operations. The goal of each task is to support the commander's intent by the most efficient means and leaving the smallest possible footprint on the battlefield. Each task has maximum reach back capabilities and minimizes manpower requirements. Focused FM support enhances the commander's ability to manage and apply available resources at the right time and place in a fiscally responsible manner. FM provides the capability for full spectrum finance and resource management (RM) support across the theater to include joint, interagency, intergovernmental, and multinational (JIIM) operations.

Financial management is composed of two core processes: finance operations and resource management (RM) operations. These two processes are similar and mutually supporting in organizational structure and focus. The organizational structure provides a complete FM package, supporting home station and operational requirements for commanders at the Army Service component Command (ASCC) level and below. The integration of finance and RM under FM offers the commander a single focal point for FM operations. The single point of contact at the ASCC, corps, and division level is the G8, who will consult with the financial management center (FMC) at the Army level and the FM SPO at the division and/or corps level. FM relies heavily on other staff elements—such as the Staff Judge Advocate (SJA), Assistant Chief of Staff (G Staffs), and contracting—to accomplish the FM mission. FM also follows policies and procedures established by National Providers, Defense Finance and Accounting Service (DFAS) and Assistant Secretary of the Army for Financial Management & Comptroller (ASA(FM&C)).

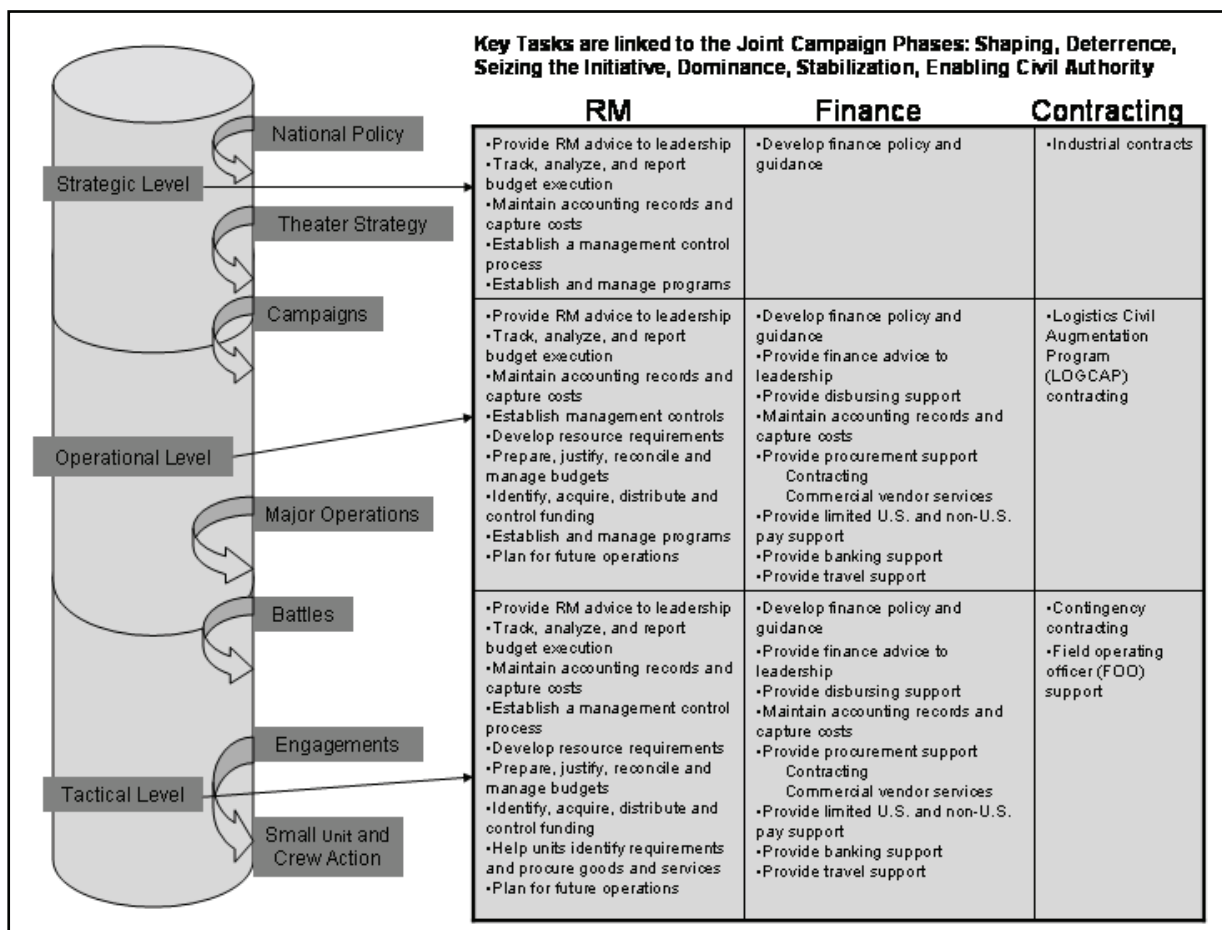

Figure I-1. The levels of FM

FISCAL TRIAD

Fiscal Triad (Figure I-2) is a concept that describes three distinct sustainment assets that support the commander's intent: finance operations, RM operations, and contracting. Together, these assets comprise a system that fulfills the full spectrum of required fiscal support, from acquisition of funds to expenditure of funds. The requirements are fulfilled by the following steps:

- The commander/staff validates each requirement.
- Resource management certifies the funds.
- The item or service is acquired by contracting.
- Finance disburses the funds.

Each element of the triad is interdependent, and works closely with the other elements to obtain products or services to meet the commander's needs. Reconciliation of requirements is a joint effort and must be synchronized within the Triad.

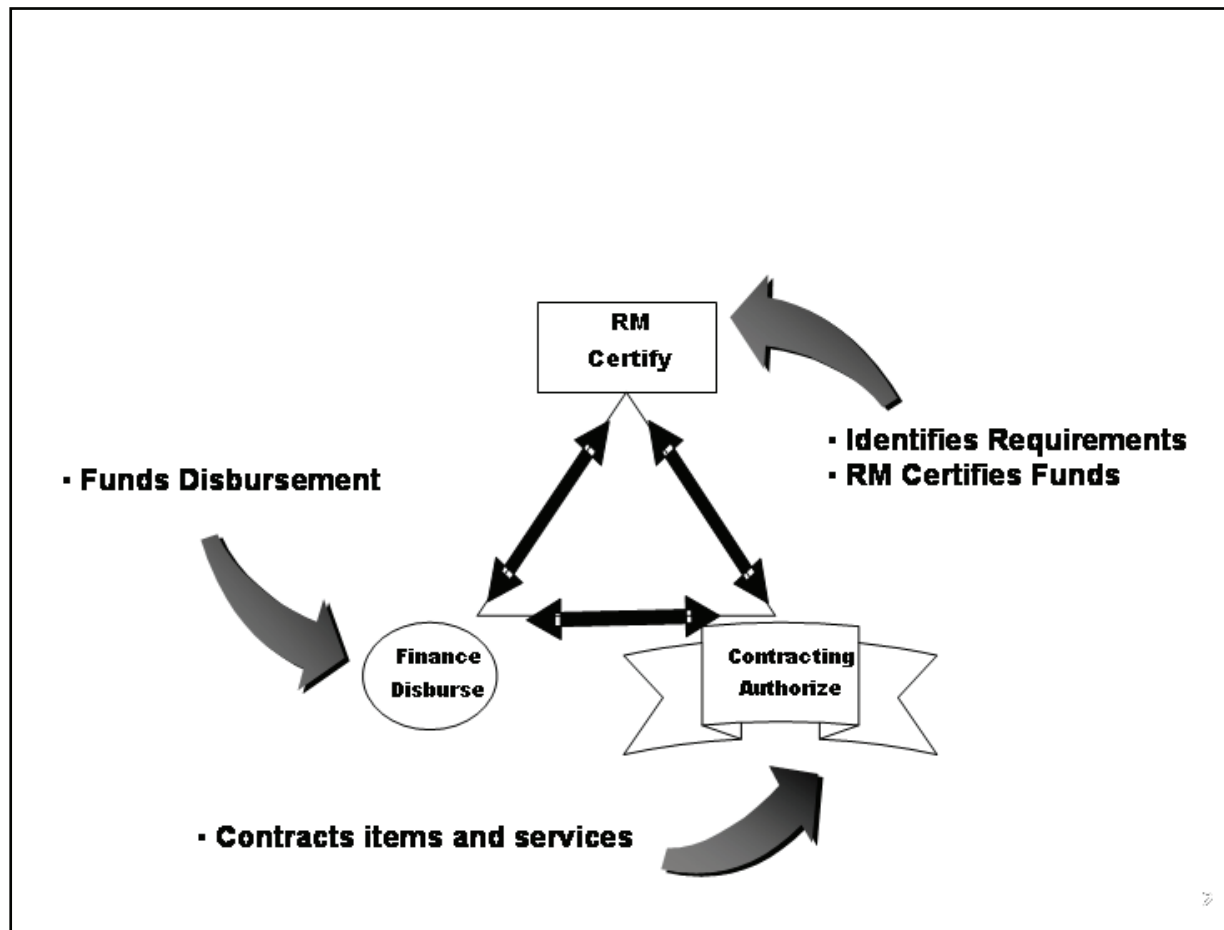

Figure I-2. Fiscal Triad

Chapter 1

Financial Management

The Financial Management (FM) mission is to analyze the commander's tasks and priorities to ensure proper financial resources are available to accomplish the mission and to provide recommendations to the commander on the best allocation of scarce resources. FM is comprised of two core functions: finance operations and resource management operations. Financial management organizations provide a wide spectrum of financial services to include:

- Providing FM support across a dispersed battlefield over extended distance and time.
- Developing fiscal guidance and ensuring regulatory guidelines, directives, and procedures are adhered to.
- Providing direct support to the Soldier Readiness Processing Center (SRP).
- Starting, adjusting and stopping deployment entitlements.
- Providing enemy prisoner of war (EPW), civilian internee (CI) and Local National pay support.
- Providing limited U.S. and non-U.S. pay support.
- Establishing banking relationships and procedures.
- Making payments on prepared and certified vouchers.
- Receiving collections.
- Receiving and controlling all currencies and precious metals.
- Tracking commitments and obligations.
- Evaluating, certifying and reporting execution of funds.
- Maintaining regulatory accountable records.
- Cashing negotiable instruments.
- Making foreign currency conversions.
- Funding FM units and determining the need for currency (US and foreign) and its replenishment.
- Protecting funds from fraud, waste, and abuse.
- Developing budgets.
- Identifying funding for resource requirements including procurement, theater infrastructure construction, materiel, services for ports, communications, and transportation networks.
- Addressing fiscal issues associated with JIIM operations, federal agencies, and nongovernmental organizations operating in the area of operations (AO).
- Establishing a management control process that provides reasonable assurance that government assets are protected and safeguarded.
- Ensuring funds and other assets are protected.
- Conducting manpower assessments.

Finance Soldiers deployed to Bosnia to support Army forces in the stabilization mission. These Soldiers deployed in harm's way—

"...When deployed, some [Soldiers] must sleep out of the back end of HMMWVs... Many must tromp through the muck and are faced with the threat of snipers and live with the fear that goes with millions of land mines....Our Soldiers, who are encamped with the combat troops they support, provide traditional Soldier pay support, contractual support, banking coordination, and central funding—all critical mission challenges."

—Comments on Operation Joint Endeavor, Bosnia

SECTION I –FINANCE OPERATIONS

1-1. The finance operations mission is to sustain Army, joint, and combined operations by providing timely commercial vendor and contractual payments, providing various pay and disbursing services, maintaining battle flexibility for combat units to engage enemy forces and following policies and guidelines established by the National FM providers. Internal force protection is an implied task of finance operations units as they are required to protect and defend themselves.

1-2. Financial management units provide support during all operational phases. The level of support varies according to the nature of the operation and depending on mission, enemy, terrain and weather, troops and support available, time available, and civil considerations (METT-TC) factors. During many operations, support for the procurement process is the FM unit's most critical mission. Effective FM support of contingency contracting efforts can make up for many logistical shortfalls. FM units may support all Services when their operations are consistent with the Combat Commander's intent.

1-3. Finance operations support must be responsive to the demands of the unit commanders at all levels, requiring FM leaders to anticipate and initiate the finance support needed. This section summarizes finance operations during all operational stages. It presents a stable body of technical principles rooted in actual military experience from which commanders can guide their actions in support of national objectives.

"The medical community is the only one that must be more technically astute than Finance. Technical competence is a must as the impact on Soldiers is tremendous."

MG Simmons, III Corps DCG

ARMY FORCE GENERATION (ARFORGEN)

1-4. The Army is no longer a peacetime army preparing for war. Peace is now the exception and deployments in support of combat operations are the norm. To meet the worldwide obligations the Army follows a structured unit readiness process, Army Force Generation. Army Force Generation (ARFORGEN) uses personnel, equipment, and training to generate forces to meet current and future requirements of combatant commanders. This cyclical readiness process recognizes not all units have to be ready for war all the time and must build their readiness over time. Units progress through the 3 operational readiness cycles or Force Pools:

- **Reset/Train.** Units returning from long term operations and are directed to reset/train or are experiencing significant organizational changes and are unable to sustain the Ready or Available levels. AC units typically stay in this pool for 6 to 9 months, while RC units will probably stay up to 4 years.
- **Ready.** Units determined to be at a ready level are capable of beginning to conduct mission preparation and collective training with other operational headquarters. They are eligible for sourcing, may be mobilized if required, and can be trained, equipped, resourced, and committed if necessary to meet operational requirements.

- **Available.** Units are capable of conducting a mission under any combatant commander. All AC and RC units pass through a 1 year Available Force Pool window. Generally AC units will rotate through this pool once in every 3 years; rotation for RC units will be once in every 6 years.

PRE-DEPLOYMENT AND MOBILIZATION OPERATIONS

PRE-DEPLOYMENT OPERATIONS

1-5. Pre-deployment operations commence when the unit is alerted for deployment. This is a critical stage for which FM units throughout the total force train. Successful force projection capabilities rely on a foundation of fully-trained, well-led, properly-equipped, and properly-sustained FM units and Soldiers. All FM units in the Army, whether AC or RC, inside the continental United States (CONUS) or outside the continental United States (OCONUS), are an integral part of the force-projection strategy.

1-6. The early and active participation of FM personnel in the deliberate and crisis action planning processes of pre-deployment operations is essential. The operational commander must anticipate finance and resource management requirements. Financial management operations are embedded in strategic, operational, and tactical plans. Tactical and operational success depends on integration of FM concepts within the plans of the supported force. Financial management plans must also be integrated with the plans of other Services, other agencies, and other partners of a multinational or joint force.

Pre-Deployment Tasks

1-7. Financial managers accomplish many tasks during the pre-deployment stage. Some of these tasks include—

- The financial management center (FMC) Chief participating in the joint planning process and conducting deliberate and crisis action planning.
- FMC receiving or determining the new accounting classification data to be loaded into FM and accounting systems.
- FMC, ASA(FM&C), the Department of State (DOS), and the Defense Finance and Accounting Service (DFAS) reviewing status of forces agreements (SOFAs), acquisition and cross-servicing agreements (ACSA) and United Nations (UN) agreements to determine FM implications for commands.
- FMC coordinating with the DOS and Treasury Department—through the United States Army Finance Command (USAFINCOM) and DFAS—to determine what foreign currency is to be used, the exchange rate(s), and if stored value cards (SVC) will be utilized.
- FMC developing, recommending, and promulgating policies for currency conversion, funding of paying agents, entitlements, foreign currency conversion, solatium payments, use of funds, identification and recording of cost data, travel, enemy prisoner of war (EPW)/civilian internee (CI) support, and bounty programs. The goal of these policies is to ensure consistency of entitlements and payments for all deployed Soldiers, Sailors, Airmen, and Marines.
- Coordinate with USAFINCOM, or the Army Service component command (ASCC), and Installation Management Agency (IMA) for establishing backfill support plans for units at home station.
- FMC recommending the proper allocation of FM units in theater.
- Coordinating with G1 on entitlements.
- Coordinating with DFAS on CONUS travel requirements.

Chapter 1

See Appendix B for pre-deployment tasks.

Finance was one of the first units on the ground in Afghanistan and immediately began building combat power. During a funding resupply mission, a Finance team was dropped off in a “Hot” landing zone, where they were required to return suppressive fire. The team remained on the landing zone until additional forces arrived and assisted in clearing the landing zone.

– Afghanistan, 1LT Leach, 126th Finance Battalion

MOBILIZATION

1-8. The Army Mobilization and Operations Planning and Execution System (AMOPES) is the guide for mobilization. Mobilization is the process by which the Reserve Component (RC) augments the active component (AC) capability in preparation for operations. Mobilization rapidly expands and enhances the response capability of the Army in a crisis, natural disaster, or contingency operation.

1-9. Several key activities that occur during mobilization are:

- Units report and go through soldier readiness processing (SRP).
- Units conduct tailored, mission-specific training (as applicable).
- Units implement load plans.
- Units depart from the mobilization station.

1-10. The FM unit at the designated mobilization station is responsible for military pay support of the RC. Coordination among the regional support command, state officials (National Guard), and the mobilization station is key to the mobilization phase.

DEPLOYMENT AND FULL SPECTRUM OPERATIONS

“My mission required me to travel into the city of Mogadishu (American University compound). Even though we traveled in a two-vehicle convoy as a force protective measure our convoy still took on small arms fire en route to the University complex.

On average, I carried approximately \$500K cash in my backpack. In addition to normal funding requirements I was also required to maintain a reserve of cash to pay for ‘Precious Cargo.’”

—Somalia, Operation Restore Hope, CPT Riley

1-11. Financial management personnel play an integral role during deployment operations. They provide critical support to the reception, staging, onward movement, and integration of forces. The early entry of FM personnel into the area of operations (AO) enables transportation units to optimize throughput. Financial managers support contracting requirements for real estate leases, dock workers, cranes, vehicles, etc. This critical FM support speeds the assembly of combat power, optimizes the use of logistics forces, and minimizes backlog and congestion. Command and control of mobilized FM units is determined early in the entry process, which ensures adequate FM support to all forces. FM units in theater provide support on an area basis. These principles apply to all FM units, both active and reserve. The FM unit maintains common situational awareness to provide support to all units and individuals in their respective AOs. **For additional information, see Appendix B.**

1-12. The initial decisions in deployment operations are often the most critical. These decisions normally fall into an early deployment time window. Once the operation begins, adjustments become more difficult. Therefore, it is critical to designate a financial management company as part of the early entry module to

establish FM requirements, coordinate logistics of the main body reception, and provide advice on available FM resources to commanders. Deployments typically require support for each of the following activities:

- Support the procurement process.
- Provide banking and currency support.
- Provide multinational support.
- Administer the savings deposit program (SDP).
- Administer the stored value card (SVC).
- Train and fund paying agents.
- Provide limited pay support
- Provide travel support.
- Support rewards programs.
- Make claims and solatium payments.
- Provide FM advice to commanders.
- Provide accounting support.

1-13. The degree to which FM units support these deployment activities depends on METT-TC. However, commanders and Soldiers must plan and train for all possible requirements. These activities are described in more detail in the following paragraphs.

SUPPORT THE PROCUREMENT PROCESS

1-14. The success of all operations depends on the support provided to the logistics system and to contingency contracting efforts. A large percentage of FM wartime efforts support the procurement process and oversight is critical in preventing improper or illegal payments. FM Soldiers coordinate with contracting officers and the Staff Judge Adjutant (SJA) regarding local business practices. Procurement support includes two areas: contracting support and commercial vendor services (CVS) support.

Support to Theater Support Contracting

1-15. Contracting support is normally a function of the FM company. It involves the payment to vendors for goods and services. Examples include all classes of supply, laundry operations, bath operations, transportation, and maintenance. FM personnel play critical roles in successful contracting operations. Financial managers must understand the key tools—such as contracting support plans (CSPs)—that contracting personnel use during operations. If there are questions on the legality of payments, the SJA should be contacted. *See FM 100-10-2, Contracting Support on the Battlefield and Appendix G for additional information on FM support to theater support contracting.*

Contracting Support Plans

1-16. The CSP is an appendix to the OPLAN logistic annex, and is the mechanism for planning for contracting support to military operations. It ensures contracting solutions are considered for all contingency operations. Prior to deployment, CSPs are normally established at the joint force commander (JFC), ASCC levels and other lower levels as deemed necessary.

1-17. Units with requirements for contracting support must communicate these requirements when developing the CSP. These units assist the contracting element by developing procedures and plans to cover contingencies. Contracting organizations, in turn, provide copies of approved CSPs to their supporting FM units.

1-18. As part of the fiscal triad, FM plays a key role in helping contracting officers establish CSPs. As a rule, FM's role in coordinating the CSP includes—

- Planning payment for contract requirements established by the unit (or units) supported under various contingencies.
- Designating, deploying, and augmenting FM units.

Chapter 1

- Defining operating procedures and responsibilities of field ordering officers (FOOs), FM personnel, and paying agents.
- Participating in site surveys and deployment exercises.
- Identifying funding and cash requirements.

Commercial Vendor Services (CVS) Support

1-19. CVS support is for the immediate needs of the force. These are needs the standard logistics systems cannot support. The financial management support teams (FMSTs) and paying agents normally pay cash for CVS (unless a credit/purchase card policy is in effect). Purchases are normally made in the local currency. Cash payments are usually for such items as pay for day laborers, Class I supplements (not otherwise on contract), and the purchase of construction materials not readily available through the contract or supply system. This type of support increases during operations in lesser developed areas and remote sites. Local procurement can augment the following supply and service areas:

- Class I: bottled water and food (within certain parameters).
- Class II: organizational equipment and clothing.
- Class III: petroleum, oils, and lubricants (POL).
- Class IV: construction materials.
- Class VI: troop support.
- Class VII: major equipment and end items.
- Class VIII: medical supplies.
- Class IX: repair parts.
- Laborers (stevedores, drivers, mechanics, etc.).
- Dining facility operations.
- Clothing exchange and bath services.
- Sanitation.
- Transportation.
- Billeting.
- Utilities.
- Maintenance and repair.
- Services (e.g. cell phones, real estate, interpreters, and rental vehicles).

PROVIDE BANKING AND CURRENCY SUPPORT

1-20. Currency support includes supplying U.S. currency, foreign currencies, U.S. Treasury checks and, in some operations, precious metals (gold, silver) to U.S. and multinational forces in the AO. FM units provide currency and coins to Army and Air Force Exchange Service facilities, tactical field exchanges (TFEs), postal units, and companies serving as in-theater defense contractors, as operational considerations permit. FM units provide cash for automatic teller machines (ATMs) in the AO. FM units also provide support for Force Provider operations, either by stocking ATMs with currency or through FMSTs collocated with Force Provider units. Commanders maximize use of existing technology, to include electronic funds transfer (EFT), to minimize the use of cash in the AO. The FMC Chief negotiates and liaises with any banking industry of a host nation (HN) to establish local depository (LD) accounts and banking procedures. The FMC may need to coordinate with the local U.S. Embassy, USAFINCOM, DFAS, and/or the Treasury Department when negotiating with HN banking facilities. Limited depository account (LDA) deposits should be made as needed to cover current contract payments and foreign currency resupply. The FMC Chief recommends guidelines for the control and use of U.S. currency and foreign currencies in the AO. The FMC can also serve as the central funding facility for all Services in the AO. FM commanders advise unit commanders on the use of local currency in the conduct of personal affairs. Restrictions may be imposed to prevent disruption of the local economy and to prevent and control black market operations and counterfeiting.

Recommend The Best Means To Control Currency

1-21. The FMC Chief recommends policies and procedures regarding limits on casual payments and check cashing amounts; however, the senior ground combatant commander retains final authority on these policies and procedures and may establish controls on the amounts of U.S. currency and foreign currency available and used on the battlefield as well as the type of currency used for contract payments. This is necessary to control black market activities, secure the money of individual Service Members, and help control problems related to currency inflation of either U.S. or the host nation currency. The use of the stored value card is a method to reduce the use of U.S. currency.

Currency Found In Personal Effects

1-22. Financial management units inventory all currency, U.S. or foreign, found among the personal effects of Soldiers and civilians captured, killed, or medically evacuated. All currency (paper, coin, precious metals), U.S. or foreign, found among the personal effects of these individuals is inventoried and turned in to the nearest FM unit.

“Money is my most important ammunition in this war.”

—MG Petraeus, 101st Abn Div Air Aslt

Conduct Currency Exchange

1-23. Financial management cashiers play an important role in currency exchanges and currency control. FM currency exchange plans must consider members of all Services, DOD civilians, authorized U.S. contractor personnel, other U.S. Government personnel, nongovernmental organization (NGO) personnel, and paying agents. Currency exchanges include U.S. currency to foreign currency and vice-versa, and one foreign currency to another foreign currency. Conversions must comply with currency control standards and discourage black market activities. Currency exchange, when done in large amounts, is very time-consuming. FM units must plan well for these operations. FM units may perform conversions due to a number of circumstances. They include: the movement of forces from one country to another, upon deployment to and departure from the AO, to prevent and control black market activities, or to help control inflation. FM units exercise caution when exchanging U.S. currency to prevent their units from becoming laundry points for enemy currency, counterfeit currency, black market operations, and currency arbitrage (profits achieved through the buying and selling of foreign currency to take advantage of exchange rate fluctuations). FM units make EFTs or may issue U.S. Treasury checks in exchange for excess currency accumulated by Service Members. Military banking facilities (MBFs), tactical field exchanges (TFEs), and nonappropriated fund (NAF) custodians may need to deposit their holdings of currency and coins with the nearest tactical FM unit. U.S. currency and coins may be turned in to the servicing FM unit in exchange for an EFT or a U.S. Treasury check. Complete changeouts from one currency to another may be required. The FMC Chief will promulgate specific policy and procedures should a changeout become necessary.

PROVIDE MULTINATIONAL SUPPORT

1-24. The FM commanders must be aware of agreements with allies or HNs, which include reciprocal financial support as authorized by DOD Directive 5530.3 (*See Department of Defense (DOD) 7000.14-R, Volume 5*). The FMC Chief or account holder is responsible for obtaining copies of these agreements and disseminating them to lower elements. These agreements will be coordinated with the Staff Judge Advocate (SJA) for legal sufficiency prior to implementation. When an agreement has been negotiated between the United States and an allied nation in accordance with this law, U.S. disbursing officers may be authorized to advance currency on an emergency basis to cashiers or members of the allied nation's armed forces. Such agreements may require allied forces to provide reciprocal support to U.S. forces. *See Section III, Chapter 1 and Appendix F for more information on FM support in a multinational environment.*

ADMINISTER THE SAVINGS DEPOSIT PROGRAM (SDP)

1-25. Financial Management units may receive deposits for the savings deposit program (SDP). Service Members can use allotment forms or can deposit checks or cash at their servicing FM unit. Authorizations of the SDP may vary according to the operation. The Office of the Secretary of Defense is the approving authority for the SDP, to include setting the maximum deposit amount and interest rate.

ADMINISTER THE STORED VALUE CARD (SVC)

1-26. The stored value card (SVC) is a plastic card with an embedded computer chip. It is a smart card with electronic value (U.S. Dollars) loaded into the computer chip. Funds are loaded on the SVC by the disbursing officer (DO) using a security access module (SAM). The funds on the cards are personal funds or a partial payment made by the DO. The authorized users pay for services and merchandise on the installation via the SVC. Merchants have terminals that debit the amount of purchase from the SVC. The SVC reduces the cash requirement in the area of operations, reduces the manual processing of SF 215s and cash collection vouchers.

1-27. Financial Management units in Contingency/Peacekeeping Operations will use the SVC system to issue electronic currency as replacement for physical U.S. currency when possible. The ASA(FM&C) establishes policy for electronic currency to replace US currency at Contingency/Peacekeeping locations. This will be accomplished through issuance and maintenance of the SVCs if authorized in the AO.

TRAIN AND FUND PAYING AGENTS

1-28. Supported unit commanders in conjunction with FM leaders appoint paying agents to perform specific duties. They are appointed either to support the local procurement process, or to provide support to individuals. Paying agents cannot perform both of these duties simultaneously. FM units train and brief the paying agent on required procedures. The FM unit requires paying agents to sign a letter of understanding prior to being funded. Commissioned officers, warrant officers, enlisted members, or civilian employees satisfactory to the appointing officer may be appointed as paying agents. *See Appendix D for more detailed information on paying agents.*

PROVIDE LIMITED PAY SUPPORT

1-29. As directed, FM units provide limited pay support to all Services (both Active and Reserve components) and DOD civilians. FM units provide support when requested by commanders and as the situation permits.

PROVIDE TRAVEL SUPPORT

1-30. The requirement for travel support to deployed personnel can be immense. During most contingency operations, per diem is limited to incidental expenses only. During the early stages of the operation, there may be extensive requirements for temporary duty (TDY) to and from the AO. Travel support also includes noncombatant evacuation operations (NEO) travel advances to non-combatants when they evacuate from the AO (emergency evacuation allowances). The DOS may issue a noncombatant evacuation order for U.S. citizens in the HN or target country. Evacuation payments are authorized under NEO conditions and are usually paid outside the target country at a pre-designated safe haven.

SUPPORT REWARDS PROGRAMS

1-31. Rewards may be used to support specific theater initiated programs such as purchasing weapons, radios, information, and other items from local nationals (LNs). The most common example of this type of program is the weapons for cash (WFC) program. This program has been used successfully in recent operations. *See Appendix P for more information.*

MAKE CLAIMS AND SOLATIUM PAYMENTS

1-32. Claims payments are monetary payments made by the United States Government for non-combat injuries or property damages. Claims are paid pursuant to the Personnel Claims Act (US personnel), Federal Torts Claims Act (US citizens), Military Claims Act (US citizens), Foreign Tort Claims Act (FTCA) (foreign personnel), or claims arising under a status-of-forces agreement. Claims will be processed and adjudicated by an area claims office or, in the case of FTCA, by a foreign claims commission. Claims payments can reach significant dollar amounts. The FM unit is responsible for the disbursement and accounting of all claims payments.

1-33. A solatium payment is monetary compensation given to indigenous personnel to alleviate grief, suffering, and anxiety resulting from injuries and property or personal loss. Solatium payments are made to meet cultural expectations and are not an admission of liability by the U.S. Government. The commander in whose AO the incident occurred is responsible for determining entitlement for solatium payments. FM units are responsible for disbursing and accounting for all solatium payments. Solatium payments must be requested through and approved by the local SJA before payment by finance. *AR 27-20 contains information on solatium payments. Also see Appendix O.*

PROVIDE FM ADVICE TO COMMANDERS

1-34. The FMC chiefs and financial management company (FM CO) commanders make recommendations to commanders on how to provide FM support throughout their respective AOs. Recommendations may cover such issues as control of black market operations, control and use of currencies, provision for consistent FM support throughout their commands, and consistency of entitlements among all Service Members.

PROVIDE ACCOUNTING SUPPORT

1-35. Accounting requirements for full spectrum operations are immense, and they begin before the first troop deployment. The quality of accounting records depends on the timely receipt and accuracy of cost data. The FMC and FM CO perform the accounting functions. The level of accounting support depends upon the level of conflict and the complexity of the operation. In addition, any reimbursement agreements in effect impact accounting reports and procedures. Close coordination with the ASCC/Corps/Division G8, FMC, and FM CO is essential in the accounting and reporting process. Effective cost capturing is achieved through a joint effort between FM and contracting personnel. From its home station, DFAS issues guidance and operates the financial systems that process all FM information transmitted from the AO.

STABILITY OPERATIONS

1-36. Stability operations offer unique challenges to the financial manager. In many instances, commanders execute these operations with little or no advance notification. Support requirements may be unique, or operations may be totally unfunded. This phase of full spectrum operations remains the most intensive for FM. During this phase, contract support, cash collections for SDP, Army and Air Force Exchange Service (AAFES) support, and general disbursing functions are an essential aspect of the operation. Under these circumstances, the financial manager advises the commander on allocation of resources, prepares the deployment team, issues funds, prepares cost estimates, and prepares to sustain the force during continuous operations.

REDEPLOYMENT AND DEMOBILIZATION OPERATIONS

REDEPLOYMENT

1-37. The objective of redeployment operations is to redeploy equipment, units, and individuals no longer needed in an operational area. Successful redeployment may require FM, contracting, and host-nation support (HNS).

Chapter 1

1-38. The FM elements incrementally redeploy in such a fashion as to ensure adequate FM support is available to support both the remaining forces in the AO and the forces at home station. FM units may provide support to a central outprocessing site in the AO and to a central inprocessing site at home station.

1-39. If not accomplished during post-conflict operations, financial managers close out the accounts of paying agents, ensure Service Members' deployment related entitlements are stopped, as appropriate, audit pay accounts, close contingency disbursing station symbol numbers (DSSNs), convert from contingency accounting processing codes (APCs) back to home station APCs, and request additional obligation authority to replace or repair damaged or destroyed equipment.

DEMOBILIZATION

1-40. Demobilization is the process by which units, individuals, and materiel transfers from active to a pre-mobilization or other approved posture. Although the overall focus of demobilization is generally on units and individuals, the demobilization of logistics also requires significant resources such as supplies, materiel, and support activities. FM support during demobilization is just as important as during mobilization. Effective support ensures a successful transition back to pre-mobilization operations. Coordination among the regional support command, state officials (NG), and the demobilization station is critical to the demobilization process.

SECTION II – RESOURCE MANAGEMENT OPERATIONS

1-41. This section covers resource management operations conducted by financial managers. Resource management capability is found at the strategic, operational and tactical levels. In this chapter, “financial manager” refers to any and all resource managers, including the comptroller, budget officer, budget analyst, etc.

1-42. The strategic level deals with attaining national objectives by the development of and use of national resources to accomplish mission objectives. At the strategic level, financial management is heavily involved in setting policy, planning resources, interpreting DOD guidance, coordinating DFAS policy and accounting policy, following congressional legislation, and maintaining effective oversight of execution at the program level.

1-43. The operational level links the tactical employment of forces to strategic objectives. Financial management provides commanders the required resources and ensures the resources are used efficiently and effectively. The operational level primarily involves executing resources, anticipating future requirements, coordinating banking operations, and planning supporting operations. At the operational level, the main objective is to set up the tactical level for success.

1-44. The tactical level is the employment of units in combat. Financial managers focus on short term objectives that enable the mission of maneuver units to succeed. The focus of the financial manager is on the immediate funding and distribution of dollars. Tactical level support may include: the commander's emergency response program (CERP) and Humanitarian and Civic Assistance (HCA) support, processing captured currency, and identifying future resource requirements.

Mission Statement

The Resource Management Operations mission is to analyze the commander's tasks and priorities and to identify the resource requirements that will enable the commander to accomplish the mission.

1-45. The RM function is a critical enabler at all levels of the Army's chain of command and across the entire spectrum of operations. Whether at the company, battalion, brigade or Headquarters, Department of the Army (HQDA) level, all commanders are ultimately responsible for resource management operations. At the lower levels in the chain of command, RM duties are usually assigned as additional duties. Whether

a financial manager is assigned to a unit or not, the commander is ultimately responsible for the proper stewardship and allocation of resources.

1-46. The financial manager provides recommendations to the commander on policy that is IAW current statutory and regulatory guidance, as well as with the guidance/policies issued by the higher headquarters. The financial manager performs a myriad of tasks, which are listed in the following paragraphs according to their place in the budget cycle.

1-47. **Program objective memorandum (POM) year(s).** For up to six fiscal years into the future, the financial manager starts allocating resources for major programs—

- Identifies and ensures requirements are validated.
- Prepares the POM.
- Defends the POM.

1-48. **Budget year(s).** For one to two fiscal years into the future, the financial manager begins converting programs into actual resources—

- Prepares the budget estimate submission.
- Prepares the adjusted budget estimate submission.
- Prepares the command budget estimate (CBE).
- Analyzes program budget decisions.
- Conducts congressional budget liaison.
- Conducts manpower assessments in coordination with Force Modernization elements at the same level.

1-49. **Current year.** In the current fiscal year, the financial manager executes the commander's programs for the appropriated dollars received—

- Publishes annual funding guidance.
- Establishes initial funding levels.
- Develops the phased obligation plan & spending plan.
- Processes Unfunded Requirements (UFRs).
- Manages Unfunded Requirements (UFR) and decrement processing.
- Prepares assessment of commander's ability to accomplish mission based on resources provided.
- Conducts program budget advisory committee (PBAC) meetings.
- Enforces management programs.
- Administers the management control program.
- Funds and monitors the Government travel card program.
- Monitors the Government purchase card program, international merchant purchase authorization card (IMPAC).
- Conducts a mid-year review.
- Conducts joint reviews.
- Performs budget execution.
- Conducts obligation management.
- Performs reimbursement processing.
- Conducts year-end close out.
- Conducts manpower assessments in coordination with Force Modernization elements at the same level.

1-50. **Prior year(s).** For the five fiscal years prior to the current year, the financial manager—

- Conducts a joint review.
- Performs obligation adjustments.

Chapter 1

- 1-51. **POM to prior years.** For the period from POM to prior years, the financial manager—
- Conducts manpower assessments in coordination with Force Modernization elements at the same level.
 - Performs cost and economic analysis.
 - Conducts resource reviews and analysis.
 - Performs budget adjustments.

1-52. The financial manager must understand the unit's mission to support the commander's intent. As the commander's honest broker, the financial manager helps to identify all fiscal and operational considerations by assisting other staff elements in validating and prioritizing requirements. This is accomplished by accurately forecasting and obtaining funds, capturing costs, and determining the correct appropriation(s) to fund requirements. Impartiality and credibility are critical in advising the commander on resourcing issues.

1-53. RM operations are an integral part of all phases of FM operations, from normal day-to-day peacetime training, through complex full spectrum operations. The financial manager is part of the battle staff and participates throughout the military decisionmaking process (MDMP) for all operations. The interface with the internal review office, the SJA, the inspector general (IG) and contracting is of particular importance to the financial manager. Resource Management operations must remain flexible and adaptable in order to support various missions, based on their type, size, intensity, and duration. FM personnel plan for 24-hour operations. The financial manager identifies, allocates, distributes, controls, and reports fund execution for separate types of appropriations for all operations. *Appendix B includes financial management deployment checklists that provides suggested RM planning and execution considerations by phase of military operation.*

LEVELS AND EMPHASIS OF PLANNING, PROGRAMMING, BUDGETING, AND EXECUTION

1-54. The RM processes are basically the same at the tactical, operational, and strategic levels, but each level emphasizes different areas. Although each unit, installation or activity has a unique set of parameters associated with the execution of its specified mission, its core RM support requirements remain the same.

STRATEGIC LEVEL RESOURCE MANAGEMENT OPERATIONS

1-55. At the strategic level, the financial manager becomes heavily involved in the planning and programming phases of planning, programming, budgeting, and execution (PPBE) while continuing to maintain effective oversight of execution at the program level. The strategic level financial manager provides the support described in the following paragraphs.

1-56. **Planning.** In the area of planning, the strategic financial manager participates in—

- Army Review Board.
- The Army Plan (TAP).
 - Army strategic planning guidance.
 - Army planning guidance.
 - Army planning guidance memorandum.

1-57. **Programming.** In the area of programming, the strategic financial manager—

- Plans evaluation groups/management decision evaluation package (MDEP) review.
- Submits the POM.
- Executes program decision memorandum (PDM).
- Reviews program budget decisions and submits reclaims to DOD.
- Implements the approved POM.

1-58. **Budgeting.** In the area of budgeting, the strategic financial manager coordinates the budget estimate submission (BES).

1-59. **Execution.** In the area of execution, the strategic financial manager—

- Distributes funds.
- Monitors execution by program.
- Conducts mid-year reviews.
- Conducts joint reviews.
- Conducts year-end closeouts.

OPERATIONAL LEVEL RESOURCE MANAGEMENT OPERATIONS

1-60. At the operational level, the financial manager begins placing more emphasis on programming and budgeting phases of PPBE while still maintaining effective oversight of the execution processes. The operational level financial manager provides the support described in the following paragraphs.

1-61. **Planning.** The operational financial manager has limited involvement in the PPBE planning cycle.

1-62. **Programming.** In the area of programming, the operational financial manager—

- Participates in POM development and submission by MDEP.
- Coordinates with HQDA and, in some cases, the Office of the Secretary of Defense, and other Services.

1-63. **Budgeting.** In the area of budgeting, the operational financial manager—

- Issues guidance to subordinate units on preparing CBEs.
- Receives and consolidates CBEs.

1-64. **Execution.** In the area of execution, the operational financial manager—

- Distributes annual funding guidance and budget and manpower guidance.
- Conducts and participates in mid-year reviews.
- Receives and distributes funds.
- Monitors the CBE execution of major subordinate commands by Army Management Structure Code (AMSCO) and MDEP.
- Conducts PBACs.
- Performs UFR/decrement processing.
- Performs obligation tracking and management.
- Publishes year-end guidance.

TACTICAL LEVEL RESOURCE MANAGEMENT OPERATIONS

1-65. The tactical financial manager participates in all aspects of PPBE. However, the emphasis is on fund execution and control. The tactical resource manager provides the support described in the following paragraphs.

1-66. **Planning.** The tactical financial manager has limited involvement in the PPBE planning cycle.

1-67. **Programming.** In the area of programming, the tactical financial manager participates in POM development and submission by MDEP to the next higher headquarters and ultimately to the Army Command/ASCC for input into the Army Command/ASCC POM.

1-68. **Budgeting.** In the area of budgeting, the tactical financial manager—

- Prepares the command budget estimate (CBE).
- Prepares field budget estimates (FBEs) for events.

1-69. **Execution.** In the area of execution, the tactical financial manager—

- Receives and distributes funds IAW the CBE or FBE.
- Executes the CBE and FBE by capturing costs by element of resource (EOR) and APC.
- Conducts unit-level PBAC meetings.

Chapter 1

- Performs UFR and decrement processing.
- Performs obligation tracking and management through manual and automated systems (for example, Dbase Commitment Accounting System (DbCAS), Army Standard Information Management System (ASIMS), Standard Financial System (STANFINS), operational data store (ODS), Integrated Logistics Analysis Program (ILAP)), to include:
 - TDY orders.
 - Contracts.
 - DD Form 448, Military Interdepartmental Purchase Request (MIPR).
 - Miscellaneous obligation documents (MODs).
 - Paying agent documents (SF 44, DD 1081).
 - Field operating officers (FOOs) documents, (DA 3953).
 - Stock fund requisitions.
 - Government purchase cards (GPCs).
 - Civilian pay.
 - Government bills of lading (GBLs).
 - Government transportation requests (GTRs).
 - Transportation account code (TAC).
- Performs commitment accounting (DbCAS operations).
- Performs fund certification and control.
- Tracks credits and credit turn-ins.
- Monitors non-stock funds orders and payables.
- Prepares staff analysis and reports.
- Provides staff input, recommendations, and advice to the commander.
- Implements and monitors the management control(s) program.
- Performs Government travel card oversight.
- Manages and maintains document registers.
- Conducts year-end close out procedures.

ESSENTIAL ELEMENTS OF RESOURCE MANAGEMENT OPERATIONS

1-70. All financial managers provide the same basic elements of support to their unit's or organization's mission. As the commander's resource advisor, financial managers perform the following tasks.

RECEIVE AND PROVIDE GUIDANCE

1-71. Resource management guidance may come from multiple sources at each level. At the tactical level, guidance is focused on executing the commander's intent while interfacing with higher headquarters. At the operational level, guidance comes mainly from the commander, HQDA directives, and The Army Plan (TAP). The TAP provides lower levels with information on Army leadership's policy and resource guidance for the long, mid, and near terms. At the strategic level, guidance is based primarily on the DOD's Strategic Planning Guidance (SPG), which is, in turn, based on the National Military Strategy (NMS). The SPG is capabilities based guidance indicating areas in which to either reduce, or accept greater risk.

DEVELOP COMMAND RESOURCE REQUIREMENTS

1-72. Each level of RM is inherently responsible for developing resource requirements. Each uses the same basic process of receiving guidance, determining total resource requirements, applying available resources to those requirements, and identifying unfunded requirements (UFRs). Furthermore, the resource manager prepares phasing plans and supporting schedules. Determining what resources are required and

available to support the mission and meet the commander's intent is a responsibility that is common to all levels of RM.

Determine Requirements

1-73. **Strategic Level.** The FM focus at the strategic level is on translating strategic budget guidance from the President, Congress, and DOD into Army manpower, force structure, and equipment requirements. There are multiple sources of guidance used at this level, for example, SPG, NMS, TAP, and other appropriate sources.

1-74. **Operational Level.** At the operational level, using cost modeling, RM begins transitioning its focus from execution to planning and programming for future requirements. Coordination with the staff, subordinate units, and higher headquarters is critical to determine and validate programming requirements. An example of operational level RM is coordinating, collecting, analyzing, and submitting a POM.

1-75. **Tactical Level.** Determining requirements at the tactical level rely heavily on the commander's guidance for training, operational plan(s), and input from the staff and subordinate unit(s). The financial manager focuses on the detailed resource requirements for each mission or task (who, what, when, where, why, and how). Armed with these details, financial managers use cost factors—cost and economic analysis center (CEAC), or historical data—to verify and validate event and task costs. Financial managers identify these costs according to element of resource (EOR), Army management structure code (AMSCO), and management decision evaluation package (MDEP).

Determine Resource Requirements

1-76. Each RM level receives resources and applies them to meet the validated requirements. If validated requirements exceed available resources, the result is a UFR. All levels use the same generic process to determine and prioritize UFRs. The command and staff at each level must determine each shortfall's impact to the mission. Based on this analysis, the commander's priorities, and fiscal strategy, financial managers recommend to the commander whether to leave the requirement unfunded, to reprogram, to realign the program internally, or to seek additional resources from higher headquarters.

Determine Costs

1-77. Financial managers are responsible to their commander when determining and validating costs to accomplish the mission. Accurate and detailed determination of costs (by functional category, class of supply, EOR, etc.) enables the financial manager to—

- Determine a baseline for future planning.
- Estimate future costs.
- Properly allocate resources.
- Develop a baseline for monitoring execution.
- Report costs.
- Seek proper reimbursement.

1-78. The process of preparing budget cost estimates in support of the commander's intent is the same as the one for developing an OPLAN. The financial manager must delineate the specified, implied, and essential tasks associated with resources, and understand the mission and commander's intent two echelons above. The financial manager must also make assumptions concerning a variety of factors (such as the operation's duration, logistic support, force size, environmental conditions, transportation, special pay and allowances, etc.). Additionally, the financial manager must consider the factors of METT-TC when developing assumptions and cost estimates.

1-79. Several methods are available to determine costs for requirements. Financial managers can estimate costs using standard cost factors or models, historical data, or the best judgment if no standard cost factors exist. Financial managers also identify requirements and get functional input and estimates.

Chapter 1

1-80. Event costing uses cost factors of like items multiplied by the numbers of items multiplied by the number of miles/days training. The training resource model (TRM) provides cost estimates for modified table of organization and equipment (MTOE) units based on equipment density, location, and miles programmed. The historical method uses past performance, and compares current or future costs based on density, duration, and/or inflation. Requirements budgeting uses current cost factors and costs, and applies them to planned requirements. Regardless of the method used, continuous staff interaction and coordination is critical.

1-81. For planning purposes, financial managers must understand costing models are just mathematical formulas using historical costs to estimate future resource requirements. Financial managers must also understand the assumptions and types of costs that are and are not included in models. It is important to remember that models provide only an estimate of future costs and may not be all-inclusive.

Develop Phasing And Supporting Schedules

1-82. In conjunction with determining what resources are available, financial managers at each level also must determine when those resources are needed throughout the fiscal year(s). Knowing when the resources are needed enables the financial manager and the higher headquarters to make resources available at the time and amount needed. This process is called phasing and follows the same procedures commanders use to phase operations. Supporting schedules include but are not limited to decrement lists, training plans, UFR lists, contracting support plans and budget manpower guidance.

IDENTIFY SOURCES OF FUNDING

1-83. The commander may have numerous sources of appropriated funds. These sources include various Army, DOD and other Federal agency appropriations and funding authorities. Within appropriations, there are budget activity groups (BAGs) and sub-activity groups (SAGs) which may require reprogramming at various command levels. It is critical that the financial manager understand the time, purpose, and amount of each funding authority. Because of the variations in and restrictions upon the various sources of available funds, financial managers must consider them all to effectively and efficiently resource the mission. Doing so reduces the immediate impact on the commander's internal funds and maximizes the commander's flexibility. Financial managers must know what costs should be obligated against what appropriation, MDEP, or AMSCO. Financial managers must understand fiscal code, the purpose of AMSCOs and MDEPs they are using, and how to write or read funding authorization and allowance documents and MIPRs. Multiple funding sources may have to be used in order to accommodate the mission and constraints imposed by fiscal law. In short, financial managers must understand funding sources to—

- Avoid Antideficiency Act violations.
- Accomplish the mission(s) assigned.
- Maximize all resourcing options.

1-84. A common scenario of using several types of funding to resource a single requirement is a combat training center (CTC) rotation. For example, funds used by CONUS units to deploy and train at Fort Irwin, CA, or Fort Polk, LA, come from several program sources within the OMA appropriation. CTC and Flying Hour Program funds are used for the training rotation to operate equipment and order supplies. CTC dollars are used for transportation, contracts, and other CTC specific requirements for the rotation. If aviation units are deployed for training, they use Flying Hours Program (FHP) dollars to operate the aircraft. Therefore, three different AMSCOs, MDEPs, and programs are used to perform one training rotation. Financial managers must determine the funding availability, source per requisition or need, and balance of these three AMSCO/MDEPs associated with the training event. Funding sources, MDEPs, and appropriations vary widely during contingency operations. *See Appendix A for additional information on legal issues. Appendix E contains a complete discussion of potential authorities and agreements.*

Receipt of Funds

1-85. Units receive their annual operating budget through the PPBE. After thorough analysis and review in the planning, programming, and budget cycles, appropriated funds flow from strategic down to tactical levels. The most common method is the flow of funds through the Program Budget Accounting System (PBAS). The PBAS transmits funding authorization documents (FADs) from the strategic level to the operational level and from the operational level to the tactical level. The tactical level financial manager may further distribute funds to subordinate units by using resource distribution documents/resource allocation documents (RDDs/RADs) or local SOP. Figure 1-1 represents the flow of appropriated funds.

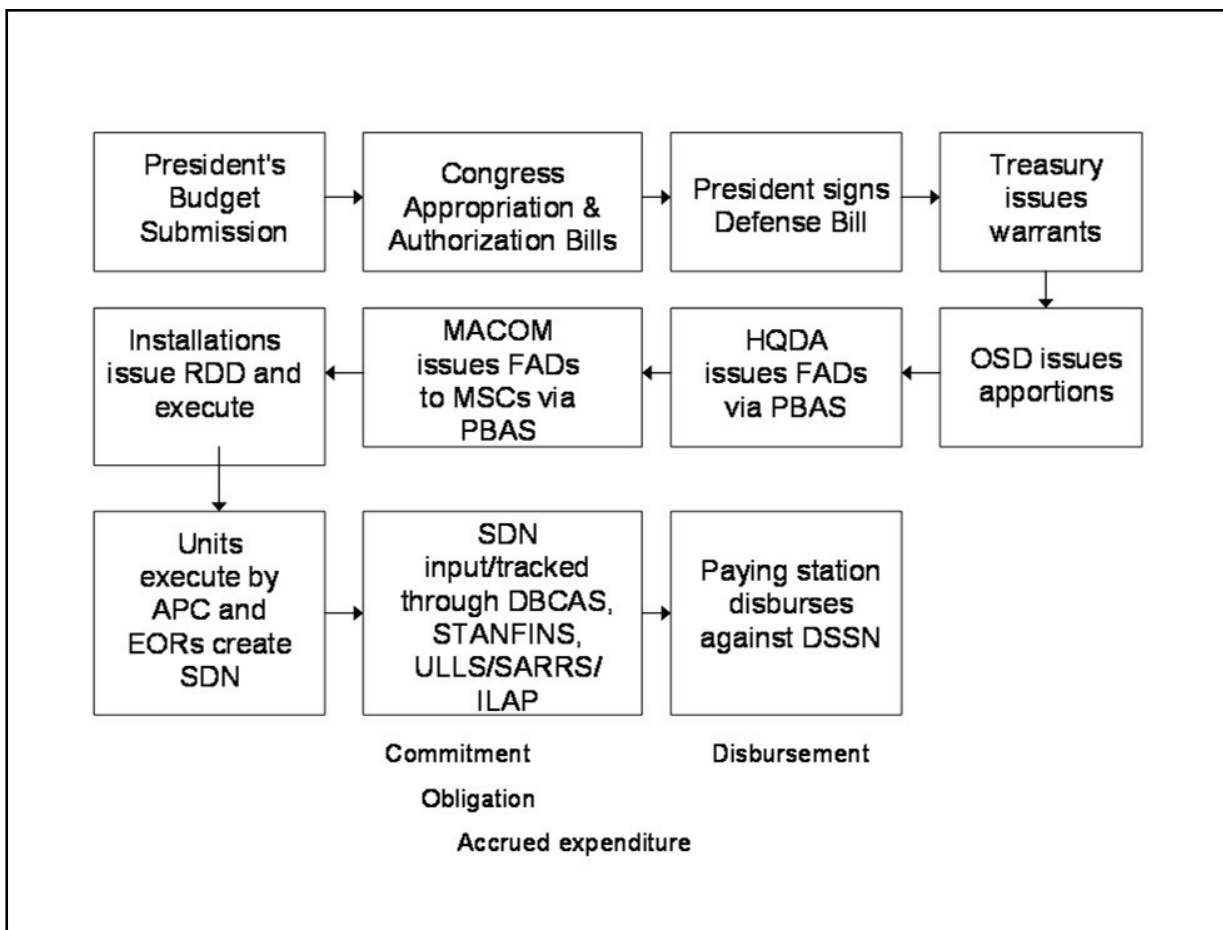

Figure 1-1. Flow of Appropriated Funds

1-86. Financial managers must understand how to read a FAD. FADs specifically list the budget activity (BA), budget activity group (BAG), sub activity group (SAG), AMSCO, direct obligation authority, funded reimbursement authority, automatic reimbursement authority, floors, fences, targets, and the quarterly amount available for obligation. Figure 1-2 depicts a FAD sent through PBAS.

Chapter 1

APPROPRIATION: 21*2020 OMA		FUNDING ALLOWANCE DOCUMENT		11:21:35 PAGE 1	
ISSUED TO: Commander, 54TH ID (M) AJKG-C FT JACKSON, SC 29207-0000		ISSUED BY: HQ USA FORSCOM AFCO-PB FT MCPHERSON, GA 30330-6000		SUSPENSE NUMBER 2020.**-9505-94763497	
ADVICE NUMBER **760940					
ALLOTMENT SERIAL FISCAL STATION 9505 S12123		EFFECTIVE DATE ISSUE DATE 01APR** 01APR**		AGENCY SVC SERIAL 76	
AUTHORITY CHANGE 2020.**-9505-76-00002					
SECTION A PROGRAM		PREVIOUS BALANCE		INCREASE/DECREASE	
REVISED NET AMOUNT					
DIRECT 110000 420000 TOTAL DIRECT		13,433,000.00 2,550,000.00 15,983,000.00		282,000.00 0.00 282,000.00	
REIMB 117000 TOTAL REIMB		85,000.00 <u>85,000.00</u>		5,000.00 <u>5,000.00</u>	
TOTAL		\$16,068,000.00		\$ 287,000.00	
13,715,000.00 2,550,000.00 16,265,000.00					
90,000.00 <u>90,000.00</u>					
\$16,355,000.00					
SECTION B ALLOTMENT BY QTR		NET CHANGE QTR 1		DIRECT: \$282,000.00	
REIMB: \$5,000.00					
QUARTER 1 DIRECT 4,097,667.00 REIMB 22,500.00 TOTAL \$4,120,167.00		QUARTER 2 8,195,333.00 45,000.00 \$8,240,333.00		QUARTER 3 12,293,000.00 67,500.00 \$12,360,500.00	
QUARTER 4 0.00 0.00 \$ 0.00					
SECTION C LIMITATIONS CEILINGS/FLOORS		PREVIOUS BALANCE		INCREASE/DECREASE	
REVISED NET AMOUNT					
DIRECT .0012 110000 REIMB UTILITIES 117000		\$3,000.00 \$85,000.00		\$0.00 \$5,000.00	
\$3,000.00 \$90,000.00					
SECTION D MANAGEMENT INFORMATION		PREVIOUS BALANCE		INCREASE/DECREASE	
REVISED NET AMOUNT					
DIRECT 0.00 REIMB 0.00		0.00 0.00		0.00 0.00	
0.00 0.00					
NAME AND TITLE OF APPROVING OFFICER: CAN U. DOIT LTC, FA BUDGET OFFICER		APPROVED BY: HECAN D. ITALL /S/ COL, GS DIRECTOR, RESOURCE MANAGEMENT			

Figure 1-2. Funding Authorization Document (FAD) Flow

1-87. Commanders face unplanned events that are not initially resourced through their normal operating budget. Some examples of these events—

- Fire fighting.
- Disaster relief.
- Emergency response.
- Humanitarian aid.
- Price changes.
- EPA fines.
- Decrements.

1-88. When unforeseen events occur, financial managers seek reimbursement of resources or additional resources through the UFR process. Additional fiscal resources may come available through—

- Defense Emergency Response Fund (DERF).
- Agency reimbursement.
- Supplemental request to Congress.
- Incremental reimbursement.
- Internal reprogramming.
- Higher headquarter reprogramming.
- Other negotiated source(s).
- Counter Intelligence Contingency Funds.
- Commander's emergency response program (CERP).
- Overseas humanitarian, disaster, and civic aid (OHDACA).

1-89. A tasking for a battalion-size fire-fighting detail is an example of when a financial manager would seek reimbursement from an outside agency. When the Army deploys a task force to assist the Forestry Service in fire fighting, the other Federal agency (in this case, the U.S. Department of Agriculture) reimburses the Army for associated costs. The U.S. Department of Agriculture is fiscally responsible for the battalion's deployment. The financial manager seeks reimbursement for transportation, contracting, supply and other costs directly associated with the deployment through operational and strategic levels. The entire RM community works through appropriate channels with the agency ultimately responsible for the mission to acquire funding. The financial manager must have accurate cost capturing methods to depict the costs by EOR for reimbursement (APC used for the event). *See Appendix E for Authority and agreement examples that further explain this concept. See the Contingency Operations section of this chapter for guidelines on reimbursable costs.*

Distribute And Control Funds

1-90. Commanders determine how their funds are distributed and controlled by the financial manager. However, certain staff elements may influence the use, release, or flow of funds in support of the commander's guidance and intent. As the commander's lead staff officer responsible for FM operations, the financial manager distributes, controls, and monitors the execution of resources. Financial managers control funds by centralized or decentralized methods. Regardless of the method, financial managers must have effective and efficient fund certification and control to maintain accuracy, ensure proper fiscal use, and capture costs.

Track Costs And Obligations

1-91. Accounting systems track costs (by event, program, unit, MDEP, and AMSCO for each transaction) based on the fiscal code. Financial managers—who must keep their commander informed on a daily basis of all aspects of FM—use the fiscal code for two main purposes. First, the fiscal code helps track expenditures at a detailed level. Second, the fiscal code helps prepare and present fiscal information to the command and staff, including the status of funds, mission or event cost, status of UFRs, and obligation rates. *Table 1-1 depicts the processing of a transaction using contractual services as an example.*

Table 1-1. Processing a Transaction		
Step	Description	Contract Example
Receive funding authority.	Funds received.	FAD.
Commit funds.	Administrative reservation of funds.	Receive DA Form 3953.
Obligate funds.	Legal reservation of funds.	Receive Contract.

Table 1-1. Processing a Transaction		
Step	Description	Contract Example
Accrue expenditure/expense.	Receipt of product or service.	Receive Goods or Services.
Disburse funds.	Payment for product or service.	Vendor receives payment.

1-92. An APC is a locally established tool that allows the financial manager the ability to capture costs and track commitments, obligations, and disbursements in accounting systems. It is a tool used to answer the question of who spent how much for what. APCs may be assigned to specific units, staff sections, events, or functions. APCs link MDEP and AMSCO with the purpose of the funding.

1-93. For example, the commander might ask the division G8, “What did 2nd Brigade spend on TDY last year?” Instead of opening the TDY file and manually calculating each travel order obligated, the financial manager uses the accounting system to search for 2nd Brigade’s APC and retrieve all EOR 21** (travel costs) for the year. The answer to the commander’s question can be found easily if the APC is established correctly and properly annotated on all applicable orders.

1-94. Each MDEP, budget activity group, or functional cost account (FCA) enables financial managers to monitor obligations. In some cases, special program codes are designated by the Chairman, Joint Chiefs of Staff (CJCS) at the operational or strategic level to capture and report costs for specific contingencies, programs, or exercises. A commander must know the status of funds (funding balance and costs per event/unit/item) to make informed resourcing and operational decisions. The financial manager obtains this information for the commander by tracking commitments, obligations, and disbursements daily.

1-95. Financial managers may determine status of funds by using a variety of automated financial systems (STANFINS, DbCAS, RM Online, ASIMS, ODS, Defense Travel System (DTS)) and by coordinating with accountants. Financial system reports assist in determining funding balance, commitments, obligation rates and ratios, and disbursements.

1-96. Financial accounts require maintenance to maintain their accuracy. A key tool used to perform maintenance on accounts is the non-stock fund orders and payables (NSFOP) report. Financial managers must continuously monitor the NSFOP to find obligations in excess of disbursements, duplicated obligations, negative unliquidated obligations (NULO), credits, and accounting or ordering mistakes. Management of this report assists in the identification of available unused funds.

The following are two account maintenance examples:

Example 1. A unit commits a \$100,000.00 MIPR (DD Form 448), for United States Transportation Command (USTRANSCOM) airlift services. The financial manager obligates USTRANSCOM’s MIPR acceptance on DD Form 448-2 (Acceptance of MIPR). Six months after the service is rendered, the NSFOP report indicates the MIPR has an accrued expenditure/expense of \$78,569.73. After confirming with the DFAS field site that all outstanding bills and services are completed, the financial manager now can request a deobligation MIPR (DD Form 448-2) from USTRANSCOM and recover \$21,430.27 from the original obligation. Thus, the unit now has an additional \$21,430.27 to obligate towards other requirements.

See Table H-7 for instructions for completing DD form 448.

Example 2. A unit has a valid requirement for a Soldier to conduct a TDY trip to a planning conference. The unit's estimate per the JFTR for transportation, per diem, and incidentals for the seven-day TDY is \$3,500. The financial manager issues a fund cite with document number on DD Form 1610 (Request and Authorization for TDY Travel of DOD Personnel), and commits and obligates \$3,500 against the unit's APC. After 60 days, the financial manager reviews the NSFOP and notices that document number has a \$3,500 obligation, but only \$2,850 disbursed. Confirming that the Soldier has completed the TDY and settled, the financial manager can now deobligate \$650 for other requirements.

Cost Capture Procedures

1-97. Financial managers must establish cost capturing procedures for both internal and external reporting requirements. This provides visibility of commitments, obligations, reimbursables, and future costs. Reporting procedures should provide accurate information while remaining simple and flexible.

1-98. Cost reports are important for a variety of purposes, including monitoring the adequacy of funding for operations. They assist all levels in monitoring the resources necessary to support operations, training, and programs. Reports help determine the impact on readiness when decrementing previously appropriated operations and maintenance Army (OMA) funds to cover contingency, base operations (BASOPS), or operational readiness (OPRED) costs. The reports also help the HQDA and DOD develop requests for supplemental appropriations and reprogramming of funds, in response to congressional or General Accounting Office (GAO) inquiries about the incremental cost of contingency operations. In addition, the cost reports facilitate congressional oversight of the expenditure of appropriated funds and their assessment of the financial impact of contingency operations on DOD spending plans.

ESTABLISH A MANAGEMENT CONTROL PROCESS

1-99. In accordance with AR 11-2, all commanders and managers have an inherent responsibility to establish and maintain effective management controls, assess areas of risk, identify and correct weaknesses in those controls, and keep their superiors informed. The financial manager coordinates management controls throughout the unit. The management control process is designed to provide reasonable assurance that established accountability and control procedures comply with applicable laws and regulations. As it pertains to FM, the management control program provides reasonable assurance that obligations and costs comply with applicable laws, that funds are protected, and that proper accounting is kept of all expenditures (stewardship). The management control process must be established as soon as possible, but not at the expense of operational or tactical considerations. *See Appendix I for additional details on management control.*

OTHER MANAGERIAL REQUIREMENTS

1-100. Financial managers at all levels monitor, implement, and control a myriad of programs and activities. Examples include the government travel card and government purchase card programs, Service-based costing/installation status reporting, the Army Community of Excellence program, the Army suggestion program, and activity-based costing.

REIMBURSEMENT PROCEDURES

1-101. Reimbursable costs may occur as a result of providing support to other organizations, units, and Services, or agencies. Support is defined as performing a service or providing a product to another organization.

1-102. Tactical and operational financial managers normally seek reimbursable costs by MIPR for funded reimbursable authority (FRA) or automatic reimbursable authority (ARA) annotated on a FAD. ARA costs are associated with an organization providing goods or services for another organization. Costs are

Chapter 1

reimbursed for only the variable EOR expenses. FRA is the authority given by an operational level unit to a tactical level unit to charge costs to a specific carrier account.

Examples:

Tactical - the United States Special Operations Command (USSOCOM) may pay the transportation costs for the Task Force 160th Special Operations Aviation Regiment to conduct joint air insertions.

Operational - the ACSA program coordinator may seek reimbursement for services or supplies provided to other countries.

1-103. The strategic level FM coordinates reimbursements from the UN, the North Atlantic Treaty Organization (NATO), foreign nations, NGOs. However, the law must authorize provisions of certain support. Throughout operations, careful consideration must be given to funding, monitoring expenditure authority (see DODFMR, Volume 15, Section 406), maintaining accountability, tracking costs, and tracking support received from or provided to the foreign nation, UN, or other designated agencies. This information is necessary to determine the detailed costs of an operation or event and to support the process of billing for reimbursement at all levels. Congress requires detailed reports on the projected and actual costs of operations. Accurate, detailed cost reports are needed to determine what EORs to charge. Financial managers capture these costs and provide the required reports and detailed billings.

1-104. When the commander establishes support agreements, the financial manager at the appropriate level should ensure the requesting units and agencies understand what assistance can be rendered. If a current agreement exists, the financial manager—with legal assistance, if necessary—reviews the agreement for proper procedures and support. If an agreement does not exist, the financial manager coordinates with the logistics and legal staff counterparts for required support. *Some of the types of authorities and agreements that exist outside normal HQDA channels are listed in Appendix E.*

1-105. Billable costs must be submitted in accordance with the provisions of regulations, the Foreign Assistance Act (FAA), other U.S. laws, and the requirements of the organization being billed. Billing information provided by components must include the documentation required by the applicable agreement(s). The financial manager at the strategic level may have to provide specific guidance for the costs that are reimbursable by another Federal agency, by a foreign government, or by private and international organizations. *See Appendix T for additional information on reimbursement procedures.*

CONTINGENCY OPERATIONS

CONTINGENCY OPERATIONS PROCEDURES

1-106. Financial managers at all levels may deal with unforeseen or humanitarian assistance missions. Units, installations, and Army Commands/ASCCs normally do not program funds for contingency operations. Nor, in most cases, are funds reserved for costs incurred in support of an unplanned event. It is usually necessary for each commander to absorb these contingency operations costs initially. Funding for contingency operations is normally drawn from current appropriations and authority, such as OMA. Requests for reimbursement are immediately requested through higher headquarters. Defense Emergency Response Funds (DERF) exist to fund initial phases of some contingency operations, but additional funding is sought to cover most contingency operations situations. Unless provided by a reimbursable agreement with another government or international organization, all financial managers coordinate for additional resources to cover costs of operations. Financial managers are responsible for ensuring the capability exists to capture all participation costs, separating and collecting the incremental and total costs, and then reporting these costs to Army Command/ASCC, HQDA, and DFAS. To assist in reprogramming and supplemental funds requests, financial managers must forecast and promptly submit requirements. It is absolutely critical to plan for and establish cost capturing procedures.

1-107. When developing command resource requirements for contingency operations, the appropriate staff section(s) must determine if there are any existing agreements, regulations, or policy guidance that the financial manager must support. Based on this staff review, the financial managers ensure adherence to proper billing and reimbursement procedures. It is important that the command resource requirements adequately reflect the concept of support. Resource requirements include, but are not limited to, contracting, transportation, multinational support, support to other agencies and international organizations, foreign humanitarian assistance, and force sustainment. The financial manager must determine the method to fund these requirements, and what appropriations, authorities, and fiscal laws apply during the contingency operations mission. *See Appendix E for guidance on appropriations, authorities, and agreements.*

1-108. In an overseas-deployed environment, host-nation support (HNS) can be a significant force multiplier. Whenever possible, local support—if available and suitable—should be considered. The Assistant Chief of Staff, G9 and civil affairs units can assist in acquiring local labor and infrastructure as an alternative to contracting services. Support agreements should include the authority for the commander to coordinate directly with the support provider for the acquisition and use of facilities, real estate, other assets, or services. The financial manager, the legal advisor, and the contracting officer must coordinate and determine specific contractor support requirements contained in these agreements. The financial manager must ensure the authority for negotiations exists through the supported combatant commander, the Joint Staff, the DOD, and the DOS.

1-109. For mission planning, once the commander selects a course of action (COA), the financial manager develops the appropriate appendix/annex in support of the MDMP. This appendix/annex must include FM policy and guidance, for example, cost capturing, additional resources, funding limitations and restrictions. This appendix/annex must adequately reflect support of logistics requirements. *Refer to Appendix C for guidance in preparing the OPLAN.*

1-110. For contingency operations, preliminary cost estimates are developed before or early in the deployment of military forces by the Under Secretary of Defense (Comptroller) (USD(C)), working in consonance with the Joint Staff, HQDA, and other agencies, as appropriate. HQDA or DOD requests for supplemental funds or reprogramming are based on detailed budget estimates. As needed, financial managers should apply the policies contained in Department of Defense Financial Management Regulation (DODFMR) Volume 2, as well as any others that describe the process for estimating costs of additional personnel and for providing logistics support to other countries and NATO components.

COST CALCULATIONS FOR JOINT EXERCISES OR CONTINGENCY OPERATIONS

1-111. Preparing cost estimates involve making assumptions about a variety of factors, including the operation's duration, logistic support, force size, and transportation. The following section describes the joint exercises and contingency operations costing methodology. When developing an estimate for contingency operations, CJCS exercises, and other unplanned events, financial managers must research and understand if full or partial reimbursement will occur. Contingency operations and CJCS exercises are funded after determining baseline, offset and incremental costs.

1-112. **Baseline Costs.** Baseline costs are the continuing annual costs of military operations funded by operations and maintenance, and military personnel appropriations. These costs are programmed and budgeted costs that would be incurred whether or not a contingency operation took place (for example, scheduled flying hours, steaming days, training days, field training exercises).

1-113. **Offset Costs.** Offset costs are costs for which funds have been appropriated but will not be obligated because of a contingency operation. In some instances, costs for which funds have been appropriated may not be incurred as a result of a contingency operation and those funds may then be applied to the cost of the operation. Examples include training not conducted, and base operations support not provided. Reported incremental costs should be reduced by the amount of these cost offsets.

1-114. **Incremental Costs.** Incremental costs are additional costs to the appropriations and are incurred only when a contingency operation is executed (above and beyond normal operations). The Department of

Defense reports the incremental costs of its participation in contingency operations. AR 350-28, *Appendix B lists in detail examples of chargeable and non-chargeable costs for CJCS exercise-specific requirements. Figure 1-3 lists examples of chargeable incremental costs and Figure 1-4 lists examples of non-chargeable costs.*

- Military entitlements, such as imminent danger pay, family separation allowance, or other payments made over and above the normal monthly payroll costs.
- Increases in the amount of allowances due to changes in the geographic assignment area due to an operation (that is, basic allowance for subsistence).
- Travel and per diem costs of active duty military personnel.
- Mobilization costs of RCs called to active duty by a Federal official and assigned solely to support the operation.
- Overtime, travel, and per diem of permanent DOD civilian personnel in support of an operation.
- Wages, travel, and per diem of temporary DOD civilian personnel hired or assigned solely to perform services supporting the operation.
- Transportation costs of moving personnel, materiel, equipment, and supplies to the operation or staging area, including port handling charges; packing, crating, and handling (PCH); first and second destination charges; and other related areas. The exception is when the Commander, U.S. Transportation Command receives a National Command Authority (NCA) order requiring transportation of non-U.S.-owned equipment and/or non-U.S. personnel. In these instances, the Army pays Military Traffic Management Command costs, the Navy pays Military Sealift Command costs, and the Air Force pays Air Mobility Command costs.
- Cost of rents, communications, and utilities attributable to the operation. Telephone service, and computer and satellite time, are examples.
- Cost of work, services, training, and materiel procured under contract for the specific purpose of providing assistance in an operation.
- Cost of materiel, equipment, and supplies from regular stocks used in providing directed assistance. Materiel, equipment, and supplies from stock are priced at the standard prices used for issue to DOD activities. Consumables such as field rations, medical supplies, office supplies, chemicals, petroleum, and items ordinarily consumed or expended within 1 year after they are put into use are included in this category. Materiel, equipment, and supplies determined to be excess to the DOD may be made available for transfer under excess property disposal authority. However, costs of work and services, to include charges for transportation of the excess property, are considered incremental costs.
- Costs incurred that are paid from the working capital funds, or other funds, whose reimbursement is required.
- Replacement costs of attrition losses directly attributable to support of the operation.
- The portion of equipment overhaul and maintenance costs that, when computed on a fractional use basis, reflect an additive cost attributable to the operation.
- Component-specific costs for increased operating tempo (OPTEMPO), such as CTC rotations.

Figure 1-3. Examples of Incremental Costs

Note: Incremental costs are additional costs to the appropriations and are incurred only upon execution of a contingency operation.

- TDY or per diem for personnel attending Service schools, orientation courses, or other school type activities.
- Cost of pre-exercise training of individuals or units. However, pre-exercise training of controllers and evaluators required by the CJCS exercise sponsor or ASCC are chargeable costs.
- TDY or per diem for unit personnel during maneuvers or exercises when rations and quarters are available or furnished, whether or not such facilities are used. (Joint Travel Regulations prohibit per diem allowances under field conditions.)
- Basic pay of regularly employed Department of the Army (DA) civilians.
- Pay or allowances of AC or RC personnel and other expenses (such as subsistence) chargeable to open allotments under the Army management structure (AMS) (DFAS-IN Manual 37-100-04).
- Cost to buy or rent items to bring MTOE and table of distribution and allowances (TDA) units to authorized levels.
- Cost to replace consumer-owned items such as parachutes, tentage, common table of allowances (CTA) 50-900, or office equipment lost or destroyed during an exercise when a report of survey or technical inspection (AR 735-5) shows that loss or damage was not a direct result of exercise deployment, employment, or redeployment.
- Cost to replace unfunded major end items (such as vehicles or weapons) lost, damaged, or destroyed during an exercise.
- Cost of nonexpendable supplies, POL, or repair parts retained by a unit or installation after an exercise.
- Cost of repair parts, POL, or supplies for maintenance, rehabilitation, painting, or repair before deployment on a CJCS exercise.
- Costs of permanent or semi-permanent construction, except costs of certain minor and temporary construction. Examples of exceptions include temporary latrines, temporary camps for use by umpires and controllers, temporary camps for the reception, staging, and onward movement of Army forces.
- All costs of Army aircraft operations, including POL, maintenance, airfield equipment, and airfield operations.
- Payment for unit parties, entertainment, alcoholic beverages, and mementos for participants except for the cost of mementos and memorabilia for allied-counterpart exercise participants authorized, per AR 350-28, paragraph B-2ab.
- Morale, recreation, and welfare support, except for the cost of Stars and Stripes or a comparable newspaper authorized per AR 350-28, paragraph B-2p.
- Existing contractual agreements that support the exercise as a supplement.
- Padlocks, footlockers, cold weather gear, wet weather gear, concertina wire, jungle fatigues, desert camouflage uniforms, and barbed wire.
- Commercial port handling charges and commercial inland transportation costs to move equipment to or from a CJCS exercise without approval of HQDA (Training Directorate Office).
- Class I (rations), or supplements to rations, such as fresh fruit or bread.
- Class V.
- Purchase by exercise participants of computers, facsimile machines, beepers, copiers, telephones and similar equipment and furnishings related to printing and reproduction.

Figure 1-4. Examples of Non-chargeable Costs

1-115. For CJCS operations, each component financial manager must comply with the reporting requirements issued by the DOD for these operations. The component must be able to account for and receive reimbursement for the costs of supporting contingency operations by meeting three conditions—

- **First**, follow consistent and approved procedures in determining and calculating baseline and incremental costs recorded in accounting records.
- **Second**, use special interest and/or program accounting codes, object class codes, and customer codes as applicable to trace costs.
- **Third**, use automated accounting systems that interface with a designated DFAS central billing system or provide a means to generate a manual bill. Cost reports are consolidated monthly and submitted through appropriate command channels to DFAS. Financial managers' capture costs using existing finance and accounting systems and procedures. These conditions are a recommended standard to seek reimbursement, standardize reporting, and maintain a common metric.

LOGISTICS CIVIL AUGMENTATION PROGRAM (LOGCAP)

1-116. The G8 must be aware of LOGCAP contracts in the AO and has the responsibility to acquire and monitor execution of these funds. LOGCAP is an US Army external support contract program designed to provide pre-planning during peacetime for the use of civilian contractors to provide selected services in wartime and other contingencies to augment U.S. forces in support of DOD missions. It is primarily designed for use in areas where no bilateral or multilateral agreements or treaties exist. LOGCAP may also be used to provide additional support in areas where there is not sufficient military support or host-nation support capabilities available. LOGCAP support is often executed in conjunction with other contractor support agreements such as theater support contracting which may require additional coordination between the FM and contracting personnel.

1-117. The LOGCAP's primary focus is to provide support and improve the operational strength of U.S. Army forces. LOGCAP can also provide support to other U.S. military Services, multinational forces, and other governmental components as directed by the CCDR and theater Army commander. LOGCAP planning and in-theater management is the responsibility of the United States Army Material Command (USAMC), through the Army Sustainment Command (ASC) and its deployable Army field support brigades (AFSBs).

1-118. Costs under the LOGCAP umbrella support contract are shared. Planning efforts are centrally funded by HQDA. Commanders must provide funding for event execution.

1-119. Funding will be provided using DD Form 448, Military Interdepartmental Purchase Request (MIPR). The customer, normally the ASCC commander, must provide funding for LOGCAP support before the Procuring Contracting Officer (PCO) issues the Notice to Proceed. *See Army Regulation (AR) 700-137 LOGCAP (currently being consolidated into AR 715-9), FM 4-93.41 Army Field Support Brigade (in development) and USAMC PAM 700-30 for additional information on LOGCAP.*

SECTION III - FINANCIAL MANAGEMENT IN JOINT, INTERAGENCY, INTERGOVERNMENTAL, AND MULTINATIONAL OPERATIONS (JIIM)

1-120. When the Army is appointed the lead Service responsible for common FM support, the FM mission during JIIM ensures the resource management, banking, and currency support needed to support all aspects and agencies involved in the mission are present. The mission also involves financial analysis and recommendations to help the joint force make the most efficient use of its fiscal resources. Effective FM support across the range of military operations is a combat multiplier in that it provides the commander with the financial resources needed to accomplish the mission. FM support structure must provide the funding essential to support contracting requirements and accomplish joint special programs. At times, the World Wide Integrated Augmentation System (WIAS) is used to augment the C/J/G8 staff. The key to proper staffing is creating a joint manning document (JMD) clearly defining duties, scope, and personnel responsibilities. A generic JMD may be found at Figure 1-5. Although each contingency operation has a unique set of parameters associated with its execution, most operations involve the following essential elements of FM operations, which are discussed in the following paragraphs.

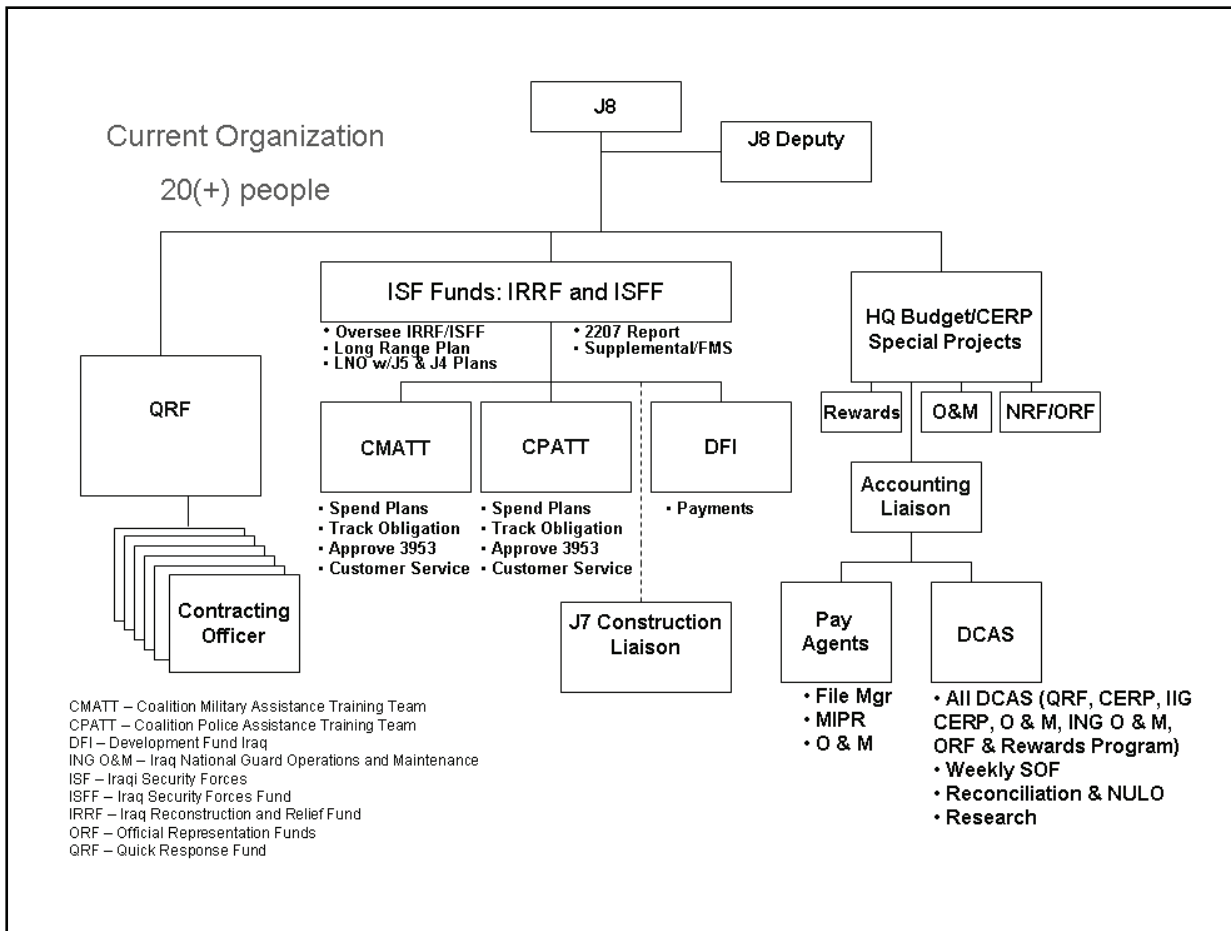

Figure 1-5. Example of Joint Manning Document (JMD)

1-121. Financial managers must be aware of the legal ramifications of operating in a multinational environment. Reimbursement and other funding issues often are complex, requiring knowledgeable financial managers. In addition to the specific agreements governing each operation, important references on multinational funding issues are contained in DOD 7000.14-R, volume 15. *Appendix F discusses financial management support to military operations in a multinational environment.*

“Financial potency determines the issues of war.”

—RADM Alfred T. Mahan 1905

PROVIDE FINANCIAL MANAGEMENT GUIDANCE AND RECOMMENDATIONS

1-122. Early and active participation by the joint task force (JTF) financial manager in the deliberate and crisis action planning processes is critical to successful integration of all components' FM operations. The JTF FM element must obtain and analyze the economic assessment of the joint operations area (JOA) and begin initial coordination with the DFAS crisis coordination center. The JTF FM element recommends JOA FM policies and develops the concept of FM operations support outlined in the FM appendix to the operation plan (OPLAN)/operation order (OPORD). Other sources of information available to the JTF FM element include the DOS, the local embassy, the U.S. Department of the Treasury, U.S. Department of Commerce, and the Central Intelligence Agency's *The World Fact Book* country reports. ***For a more detailed description of and instruction on the economic analysis, refer to JP 1-06.***

SUPPORT THE PROCUREMENT PROCESS

1-123. Support of the sustainment system and contingency contracting efforts are critical to the success of all joint operations. Army FM units, when required, provide funds for the local purchase of goods and services. Often, it is more economically efficient to purchase locally than to transport from a home station. A large percentage of the FM unit's contingency effort is directed toward execution of this function.

PROVIDE LIMITED PAY SUPPORT

1-124. The FM representative coordinates with component commands, as necessary, to facilitate payments and ensure Service Members from all components are receiving financial support. This support includes administering casual payments, cashing checks, processing travel pay, and converting local currency.

1-125. Various entitlements have been established to compensate military members for the rigors and sacrifices caused by different types of military operations. In recent years, joint force commanders (JFCs) and staffs have become more involved in making entitlement determinations and ensuring equity among participants in joint operations.

NONCOMBATANT EVACUATION OPERATIONS (NEO)

1-126. It may become necessary to evacuate family members and other noncombatants (as determined or requested by the DOS) from overseas areas with little advance notice. Circumstances will arise when the sponsoring member is not available to provide adequate funds to cover the costs of travel, subsistence, and other essential expenses that non-combatants may accrue during evacuation.

1-127. When the combatant commander, DOS, or other authorized U.S. official orders the evacuation of all non-combatants, any FM unit may make an advance payment, dislocation allowance (DLA) payment, and/or travel payment to the non-combatants. These payments are normally only at the safe haven or home station.

1-128. Evacuees may be sent to a safe haven inside or outside the AO or to another designated location (normally in CONUS). If family members are evacuated to a safe haven, they receive FM support from the FM unit or organization servicing the safe haven area.

1-129. The evacuation of DOD civilians and their family members from overseas areas follows the guidance in joint Federal travel regulations (JFTR), Volume 2, and applicable DOS regulations. ***For more information on NEO, see FM 3-07.***

JOINT OPERATIONS AND CONTINGENCY OPERATIONS FUND ACQUISITION

1-130. Once potential sources and authority of funds are determined, financial managers request use of various funding authorities. In order to control costs, the establishment of a Joint Acquisition Review Board (JARB) may be required by the senior mission commander. In many cases, contingency operations require supplies and services not available through the normal funding process. In such cases, financial managers seek separate obligation authority through the appropriate channel. One example is funding for transportation required in support of humanitarian relief operations. Assistance of this type is commonly referred to as the Denton Program and is jointly administered by the U.S. Agency for International Development (USAID), the DOS, and the DOD. The Defense Security Cooperation Agency (DSCA) manages the program and the funds. The supported combatant commander should forward requests to the Joint Staff for approval by DSCA.

JOINT ACQUISITION REVIEW BOARD (JARB)

1-131. A JARB may be established to further validate contingency requirements. The JARBs are comprised of staff officers designated by the commander. The JARB will routinely convene to review resource requirements within the AO. The purpose of the JARB is to maximize scarce resources by:

- Validating requirements.
- Ensuring resources are used efficiently.
- Identifying redundant efforts.
- Seeking alternative resources.
- Ensuring priorities are maintained.

JOINT OPERATIONS BILLING

1-132. Given the legal restrictions on the use of reimbursed expenses and to ensure timely recoupment of reimbursable costs to the components, operational and strategic level financial managers must closely follow contingency operations billing procedures. *See Appendix F for a detailed discussion of financial support to military operations in a multinational environment. See Appendix T for additional information on reimbursement procedures.*

HUMANITARIAN ASSISTANCE AND DISASTER RELIEF

1-133. Humanitarian assistance and disaster relief operations are normally of relatively short duration—usually less than 12 months. When the Army and the other Services provide assistance to an area outside the United States, other nations participating in the relief operation will likely provide some financial assistance. At the same time, U.S. costs will be incurred in providing support to other participating nations.

1-134. Due to the nature of the emergency, participating forces must engage in operations with minimal planning. Other Federal departments and agencies will also be involved. The Federal Emergency Management Agency (FEMA) operates for domestic disasters. The U.S. Agency for International Development (USAID) and the Office of Disaster Assistance operate for foreign disasters. These organizations address FM issues related to reimbursement, burden sharing, assistance in kind (AIK), and cash contributions from other nations.

NATION ASSISTANCE

1-135. Nation assistance involves a nation's effort to promote development, ideally through the use of its own resources. The goals of nation assistance are to promote long-term stability, develop a supportive infrastructure, promote strong free-market economies, and provide an environment that allows for governmental transition.

Chapter 1

1-136. Nation assistance operations are normally of long duration and extreme expense. Financial managers perform more detailed FM operations during these efforts than they do during combat operations. Financial managers may face increased funding challenges because public and political considerations may have a significant impact on the availability of funding. Meeting long-term FM challenges requires financial managers to be particularly proactive in planning FM support operations, capturing cost data, and seeking reimbursement.

PEACE OPERATIONS

1-137. Peace operations, often conducted under UN control, generally allow only minimal or moderate planning time. There may not be time to develop and disseminate cost accounting and cost sharing guidance. Therefore, early development of FM elements is necessary to ensure the appropriate level of support for procurement efforts and the accounting process. FM Soldiers will also interpret, coordinate, and disseminate FM guidance to operational commanders.

1-138. Proper cost accounting is necessary to determine the detailed cost of an operation or event and to support the process of billing for reimbursement at all levels. Financial managers must carefully track and record all cost items as if they will be reimbursed by the applicable nation or other designated agency. The UN reimburses countries for the costs of operations IAW its standard procedures and other agreements. Congress also requires detailed reports on the projected and actual costs of operations. *See Appendix T for further information on reimbursement procedures.*

Chapter 2

Financial Management Organizational Structure, Roles, and Responsibilities

Army FM functions are performed at the strategic, operational, and tactical levels. FM leadership is responsible for planning, preparing, executing, and assessing the FM mission in coordination with the combatant commander's OPLAN/OPORD. FM command and control provides a modular and adaptable structure to support the combatant commander, while simultaneously reducing the FM footprint. FM integrates two related, but independent capabilities—finance operations and resource management operations—to provide streamlined FM support across full spectrum operations. This chapter describes the FM force structure, the capabilities of each of the organizations, and the FM functions performed at each level.

SECTION I –COMMAND AND CONTROL

2-1. Command and control consists of those functions and tasks related to supporting the exercise of authority and direction by a properly designated commander over assigned and available forces. Effective command and control demands superior decisions—decisions that are both timely and more often effective than those of the enemy. The outcome of major operations depends not only on superior information, but also on superior decision-making. Decision-making often requires leaders to judge the quality of information received through staff analysis and technical sources. It also requires leaders to focus subordinates on information they consider important. These are tactical, operational and strategic judgments. Guided by doctrine, leaders make decisions using judgment acquired from training, experience, study, imagination, and critical thinking.

2-2. Leaders are the key to command and control. They drive the process to produce and execute effective decisions. They combine the art of command with the science of control and train subordinate commanders to do the same. However, they do not do this alone; they use their command and control (C2) systems, defining and focusing them in the direction they desire.

STRATEGIC FINANCIAL MANAGEMENT

2-3. Financial management at the strategic level deals with attaining national objectives. The role of financial managers at the strategic level is to support the combatant commander's strategic logistics concept, theater security cooperation, nation building strategy, and efforts to implement national policy. Financial managers follow statutory and regulatory requirements and congressional or administration mandates when they support the combatant commander's concept. The ASA(FM&C), USAFINCOM and DFAS, may provide guidance and implementing instructions for strategic FM. However, direct communication between Army FM organizations and the combatant commanders is critical.

2-4. The ASA(FM&C) issues guidance and policies regarding all FM issues within the Army. The ASA(FM&C) allocates funds for programs appropriated by Congress, monitors their execution, and recommends major reprogramming of funds in coordination with the DA staff. The ASA(FM&C) coordinates the efforts of all U.S. Army elements involved in maintaining the overall FM system.

2-5. The USAFINCOM, as a field operating agency of the ASA(FM&C), is the link for tactical units to HQDA, U.S. Treasury, Federal Reserve Banks (FRB) and DFAS for all finance operations. USAFINCOM is the HQDA finance strategic management arm performing: oversight and policy for Army finance

Chapter 2

operations; Army liaison with DFAS, U.S. Treasury, and Federal Reserve Banks (FRB); Army coordination for finance audits; the Army banking program; strategic insertion of finance automation; and internal Army cross functional & staff coordination.

2-6. The DFAS is responsible for DOD finance and accounting policies, procedures, standards, and systems operated by deployed FM units, and sustaining base operations in support of combatant commanders and the Army. DFAS also may provide liaison personnel to augment the FM staff to assist in establishing theater accounting requirements.

OPERATIONAL FINANCIAL MANAGEMENT

2-7. Financial management at the operational level links strategic and tactical level FM. Operational FM includes the FM support required to conduct campaigns and major operations. FM at the operational level complements the sustainment focus on theater support operations involving force generation, force sustainment, and redeployment (see CJCSM 3500.4D, OP 4.4.2).

2-8. The G8, in consultation with the FMC Chief is responsible for those operational FM tasks supporting the theater. The ASCC G8 advises the theater commander on laws and FM regulations governing obligations, expenditures, and limitations on the use of public funds.

TACTICAL FINANCIAL MANAGEMENT

2-9. Financial management at the tactical level generates and sustains combat power. The focus of tactical level FM is to provide the FM support necessary to meet the commander's intent and concept of operations, and to maximize freedom of action. FM must provide coordinated and tailored support at the critical place and time. The commander's FM levels of support are depicted in Figure 2-1.

2-10. Financial management conducts a large portion of its wartime functions at the tactical level. The G8, in consultation with the FMC Chief, is the principle staff advisor to the ASCC, division and corps commanders, and the staff and subordinate commanders in all matters relating to FM operations. The financial management company (FM CO) commander exercises command and control of the company headquarters and three to seven financial management detachments (FM DETs).

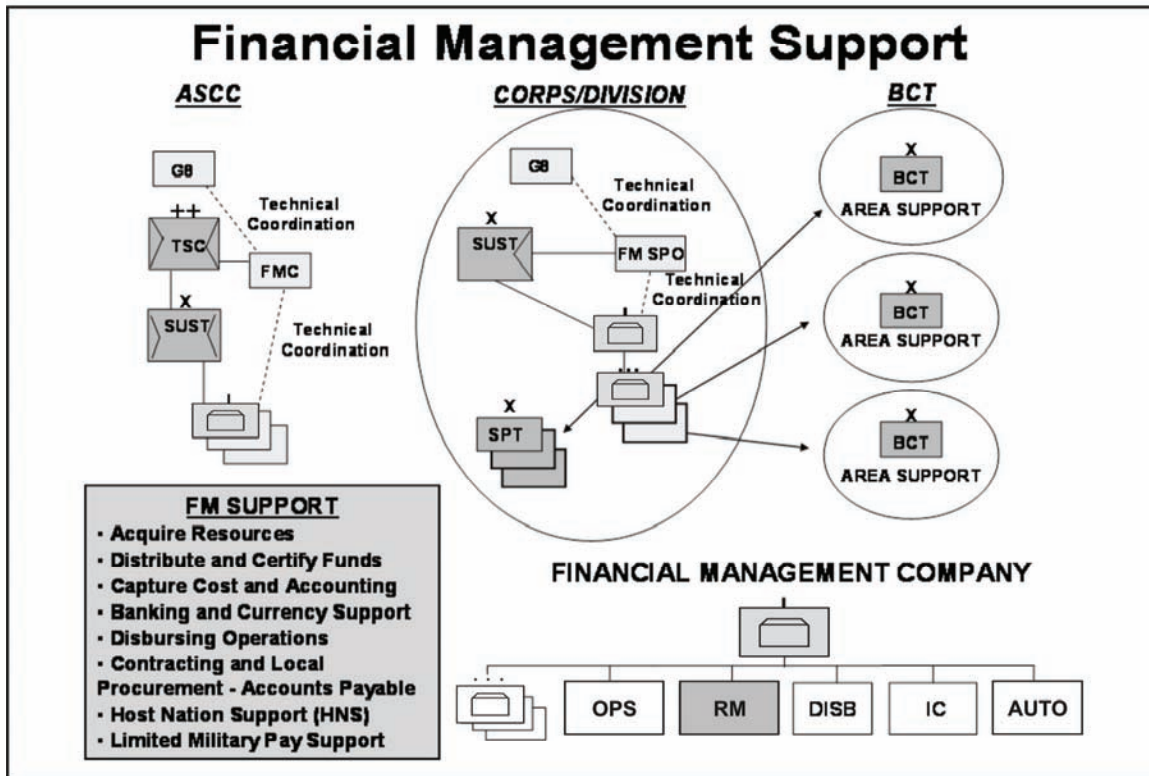

Figure 2.1. Financial Management Levels of Support

SECTION II – COMMAND AND CONTROL RELATIONSHIPS

FINANCIAL MANAGEMENT CONCEPT OF SUPPORT – ASCC

2-11. The ASCC is the primary vehicle for support to the entire region to include joint, and multinational forces deployed to a Joint Operational Area (JOA). There will be one ASCC for each geographic combatant commander, and any sub-unified command designated by the Secretary of Defense. The ASCC commander performs the service unique functions and tasks for the geographic combatant commander. In major combat operations, the ASCC may become the joint force land component commander (JFLCC) and exercise operational control over tactical forces. It can also provide the headquarters for a joint task force (JTF) in smaller scale contingencies.

ASCC G8 MISSION

2-12. The G8 coordinates and synchronizes resource requirements identification and fulfillment methods by identifying types (OHDACA, MILCON, operation & maintenance (O&M), other procurement Army (OPA), etc.) and sources of funding for administrative control (ADCON) and Army support to other Services (ASOS) functions. It provides advice and guidance concerning resource planning and execution to commanders and staff. It also synchronizes RM operations between command posts (CPs) and performs management requirements as determined by the commander. Figure 2-2 reflects the G8 organizational structure.

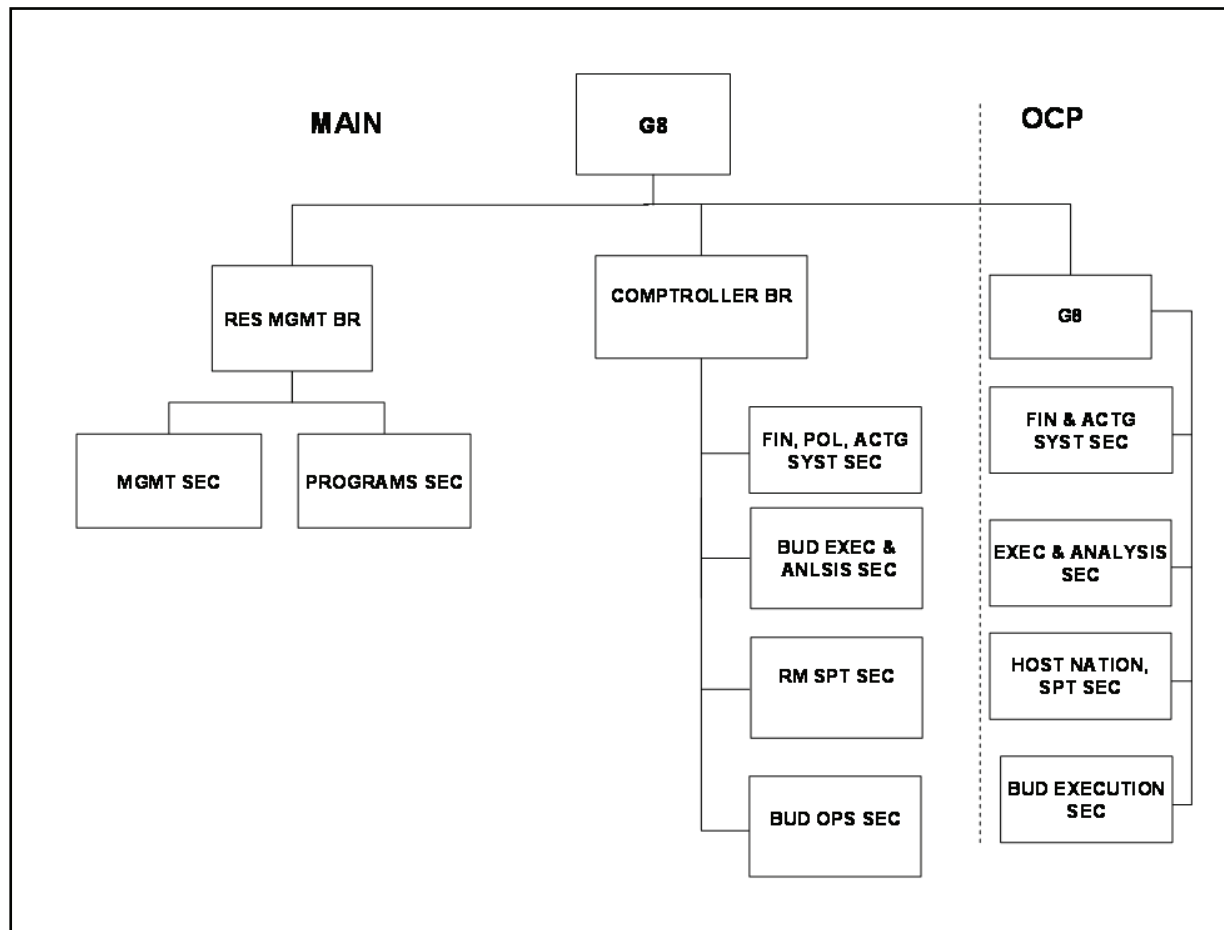

Figure 2-2. ASCC G8 Organizational Structure

“No Division or Corps commander would go to war without his Financial Managers – Three key members will always have access to the commander, the G3, the Lawyer, and the Comptroller.”

MG Simmons, III Corps DCG

HQs Sect Dir ASCC G8 (Main)

2-13. The G8 Main is the principal staff element responsible for supervising, providing leadership, and advising the commander on ADCON and FM functions within the AO. The G8 Main performs the following functions:

- Acquires, manages, and distributes funds.
- Manages DOD resources.
- Plans programs and budget.
- Coordinates and supports accounting.
- Supervises and provides leadership to the G8 staff (Comptroller & Resource Management Branches).

Dir/ASCC G8 Operational Command Post (OCP)

2-14. The OCP provides deployable staff to synchronize FM operations between deployable CPs for policy, advice, assistance, & technical oversight for the JOA. It also supports the acquisition process in the JOA.

Dir/ASCC G8 (Main) Div/Resource Management Branch

2-15. The Resource Management Branch plans and coordinates financial management support. It creates force flow for financial management forces. The branch prepares financial management annexes in support of orders/plans. It coordinates administrative control (ADCON) and Army support to other Services (ASOS) RM functions. The branch synchronizes RM operations between CPs. The branch coordinates tactical RM support for major operations and monitors the orders process for resource implications. The Resource Management Branch performs the following functions:

- Supervises and provides leadership on management and program guidance based on command priorities.
- Supervises command and staff programming/PPBE support to geographic combatant commander, managerial programs, and analysis.
- Manages a Management Section. This section supports JTF and Army forces (ARFOR) by reviewing and coordinating contingency cost estimates. It supports the acquisition process (RM, finance (FI), contracting officer, Paying Agents, Field Ordering Officers). The section monitors the orders process for resource implications. The section plans and coordinates financial management support and prepares financial management annexes in support of orders/plans. It prepares contingency cost estimates. The section performs the following functions:
 - Coordinates & synchronizes inter-service support agreements, memo of understanding, and memo of agreements for inter-service or inter-agency support requirements.
 - Administers the management control program and other managerial programs.
 - Validates cost factors associated with requirements.
 - Conducts contract cost analysis and provides review and analysis of selected topics as determined by the commander.
 - Coordinates audits.
- Manages a Programs Section. This section acquires funds by participating in the PPBE process, to include submission of required documents (BES, IPL, POM, etc.). It is the command fiscal expert and advisor on DOD, Joint Chiefs of Staff (JCS) and DA planning and programming documents (SPG, TAP, etc.). The section monitors legislative initiatives to assess impacts and provide input to Congressional Liaison personnel. It performs the following functions:
 - Produces extended future year plans; associated programs and supporting budgets IAW national and DOD policy guidance and the NMS.
 - Provides policy guidance for contingency planning and fiscal guidance.
 - Determines the constrained mix of assets which best satisfies the defense posture expressed in the National Military Strategy, SPG, and other higher headquarters directives.
 - Prepares the program objective memorandum (POM) and integrated priority list (IPL).
 - Provides advice with the G9 on inflationary trends, international balance of payments, and related wartime/contingency issues.
 - Conducts economic impact assessments of the AO with the G9.
 - Reviews and analyzes change proposals, program budget decisions s), program decision memorandum (PDM), joint quarterly readiness review (JQRR) and Joint Requirements Oversight Council (JROC).

OS Dir/ASCC G8 (Main) Div/Comptroller Branch

2-16. The Comptroller Branch coordinates and synchronizes resource requirements identification and fulfillment methods by identifying types (OHDACA, MILCON, O&M, OPA, etc.) and sources of funding. It provides advice and guidance concerning resource planning and execution to commanders and staff. This branch synchronizes RM operations between CPs and performs management requirements as determined by the commander: It provides the following functions:

- Supervises and provides leadership and guidance for budgeting, receipt, distribution, and execution of funding based on command requirements and priorities.
 - Supervises and manages system oversight cell for PBAS operations, financial database maintenance, Accounting Transaction Ledger Archival System (ATLAS) and DbCAS.
 - Supervises the Accounting Branch that is responsible for joint reviews, cost accounting, past year liquidation, past year trend analysis, and management accounting support.
- Supervises command finance and accounting programs policy, advice, assistance, and technical oversight during the MDMP process for current and future operations.
 - Provides financial management unit sourcing in force flow planning, operational planning group member, future operations coordination, and theater finance policy.
- Manages a Host Nation Assistance Section. The Host Nation Assistance Section reviews theater-wide international arrangements and assesses financial impacts. The section monitors theater-wide logistics systems for financial feasibility, in particular stock fund and repair parts systems. It supports development and review of logistical support plans. The section monitors and analyzes strategic lift costs and participates in acquisition review boards. The Host Nation Assistance Section also performs the following functions:
 - Coordinates with host nations for agreements on host-nation support (HNS), assistance in kind, and reimbursable costs.
 - Participates as required in host nation negotiations.
 - Prepares HNS reports as required.
 - Determines impact to burden share between the host nation and command.
- Manages a Finance, Accounting, Policy & Systems Section. The Finance, Accounting, Policy & Systems Section coordinates with the Financial Management Center to establish and implement command finance and accounting program policies. The section provides finance and resource systems integration/automation support to command, staff, and subordinate units. It provides fiduciary advice, assistance & technical oversight during MDMP for current and future operations. The section determines the best practices and most efficient fiscal COAs. It identifies and manages funds available for immediate expenses. The section captures operational costs via standard accounting systems and the management of the operations systems that pay personnel and providers (contractors, host-nation, supplies, etc.). Account for DOD real estate, equipment, supplies, personnel, other assets, and funds in accordance with established policy.
- Manages a Budget Execution & Analysis Section. The Budget Execution & Analysis Section is responsible for budget execution in support of theater wide operations. It coordinates within the Army staff, with supporting units, host embassies, host nation personnel and the Unified Command. The section receives, obligates and monitors disbursement of funds while complying with laws and policies. The Budget Execution & Analysis Section performs the following functions:
 - Establishes accounting systems and policy for normal OPTEMPO and contingency operations requirements.
 - Provides fund control, monitors fund execution, tracks and reports costs and obligations.
 - Responsible for MIPRs, purchase request and commitment (PR&Cs), TDY processing, DbCAS operations, files maintenance and DTS Management.
- Manages a Resource Management Support Section. The Resource Management Support Section provides exercise specific PPBE support and logistical system interface with accounting systems. The section monitors Army exercise budget execution for legal compliance & policy. It identifies and manages funds available for immediate expenses. The section performs analysis,

Financial Management Organizational Structure, Roles, and Responsibilities

planning, administration, and control of human, fiscal, financial, material, and other DOD resources.

- Provides cost and economic analysis, current operations forecasting, current year analysis, LOGCAP costing and support, and strategic lift forecasting and tracking.
- Manages a Budget Operations Section. The Budget Operations Section plans and coordinates financial management support. It prepares financial management annexes in support of orders/plans. The section coordinates ADCON & ASOS RM functions. It synchronizes RM operations between CPs. The section coordinates tactical RM support for major operations. It monitors the orders process for resource implications. The Budget Operations Section has the following capabilities:
 - Provides a deployable staff to synchronize FM operations between deployable CPs for policy, advice, assistance, and technical oversight for the AO.
 - Provides horizontal staff integration for RM support, operational planning, budgeting, and execution.
 - Prepares and reviews financial management annexes in support of orders/plans in concurrence with adjacent and subordinate staff.
 - Monitors contingency operations budget execution for compliance with fiscal law and current policy directives.
 - Supports the acquisition process in the AO.
 - Identifies and manages funds available for immediate expenses.
 - Provides advice to commanders on financial management implications and costs of preparing for and conducting operations.
 - Tracks and reports costs of battlefield operations to support reimbursement of costs initially paid from available training and readiness funds.
 - Obtains guidance on fund citations and funding levels and provides this guidance to tactical resource managers and supporting finance elements.
 - Provides fund control, monitors fund execution, tracks and reports costs and obligations.
 - Participates in resource review boards (Combined Acquisition Review Board (CARB) and JARB) as appropriate.

FINANCIAL MANAGEMENT CENTER (FMC)

2-17. The FMC Chief, in coordination with the G8, is the principal advisor to the theater commander on all aspects of finance operations. The FMC is assigned to the HQ, Theater Sustainment Command (TSC) and asserts technical coordination over all FM COs and detachments in theater. The FMC provides technical oversight of all theater finance operations including: negotiations with host nation banking facilities, advising unit commanders on the use of local currency, and coordination with national providers (U.S. Treasury, DFAS, ASA(FM&C) and USAFINCOM) to establish FM support requirements. The FMC sustains Army, joint and combined operations by providing timely contractual and procurement payments and theater disbursing capability. The FMC functions include:

- Advising unit commanders on the use of local currency in the conduct of personal affairs.
- Developing FM policy and procedures for theater implementation, in coordination with the G8.
- Preparing FM annexes in support of orders and plans.
- Providing advice regarding the interpretation and dissemination of FM directives, policy, and guidance developed by the national providers.
- Identifying FM force structure requirements and playing a key role in the force flow of FM units.
- Implementing and enforcing Internal Control measures.
- Performing both appropriated and nonappropriated fund (NAF) accounting for the theater.
- Maintaining accounting records and reporting the status of appropriated and NAF funds distributed to the supported commands.

Chapter 2

- Collecting and reporting NAF accounting data, disbursing NAF, and preparing NAF instrumentalities (NAFIs) payrolls.
- Funding (U.S. and foreign) currency for the theater.
- Coordinating with host nation and military banking facilities to provide currency to FM units and other Services or allied forces in accordance with inter-service and inter-governmental agreements.
- Coordinating the establishment of local depository (LD) accounts in theater.
- Establishing and maintaining the FM information network in coordination with theater signal providers.
- Coordinating the installation of software and hardware updates to the financial management tactical platform (FMTP).
- Ensuring system integrity against computer viruses by enforcing appropriate system security measures.

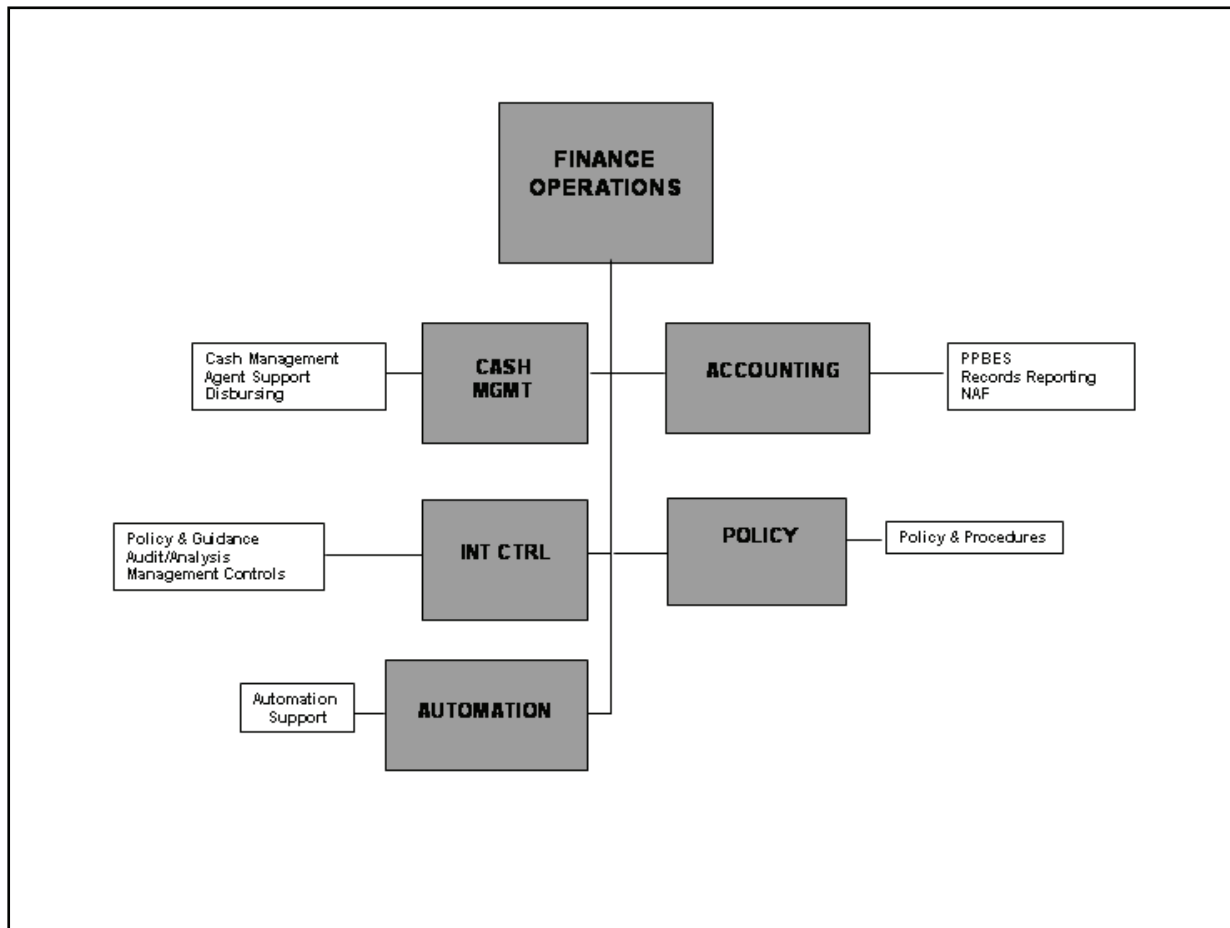

Figure 2-3. Financial Management Center (FMC) Organizational Structure

Cash Management Section

2-18. The Cash Management Section is responsible for theater currency (U.S. and foreign) support. The section coordinates with host nation and military banking facilities to provide currency to the FM COs and other Services or allied forces in accordance with interservice and intergovernmental agreements. The Cash Management Section maintains a disbursing station symbol number (DSSN), and may be designated to provide currency to all components of a joint and/or multinational force. The chief of the Cash

Financial Management Organizational Structure, Roles, and Responsibilities

Management Section is the U.S. Treasury account holder for the central funding account and coordinates the establishment of any local depository (LD) accounts in theater.

Internal Control (IC) Section

2-19. The Internal Control (IC) Section operates under the direct control of the FMC Chief to ensure a high state of technical proficiency is maintained in all operational elements of the FMC and subordinate FM COs and detachments. The IC Section evaluates the effectiveness of existing procedures and internal controls, and ensures compliance with applicable regulations, directives and management controls.

Automation Section

2-20. The responsibility of the Automation Section is to support the information operations of the FMC. The section coordinates and provides installation of software and hardware updates to the financial management tactical platform (FMTP). It interfaces with the supporting signal unit for communications coordination requiring external maintenance support of the system. The section ensures system integrity against viruses and ensures appropriate systems security measures are in place.

Accounting Section

2-21. The Accounting Section performs accounting functions not retrograded to DFAS. The section is responsible for performing appropriated and nonappropriated fund accounting for the theater. This mission includes maintaining accounting records and reporting the status of all funds distributed to the supported commands.

Policy Section

2-22. The Policy Section provides advice regarding the interpretation and dissemination of FM directives, policies, and guidance. During the pre-deployment stage, the section chief recommends which FM functions will be established in theater, and which functions to retrograde to DFAS. The Policy Section provides technical operating guidance and data management for FM functions, and provides guidance for the types of funds, use of funds, and accounting of funds for the operation. This section also coordinates civil-military operations with the Assistant Chief of Staff for Civil-Military Affairs (C/J/G9), and provides advice on inflationary trends, international balance of payments (IBOP), and related wartime and contingency economic issues. This section conducts economic impact assessments of the AO in concert with C/J/G9 and civil affairs officials.

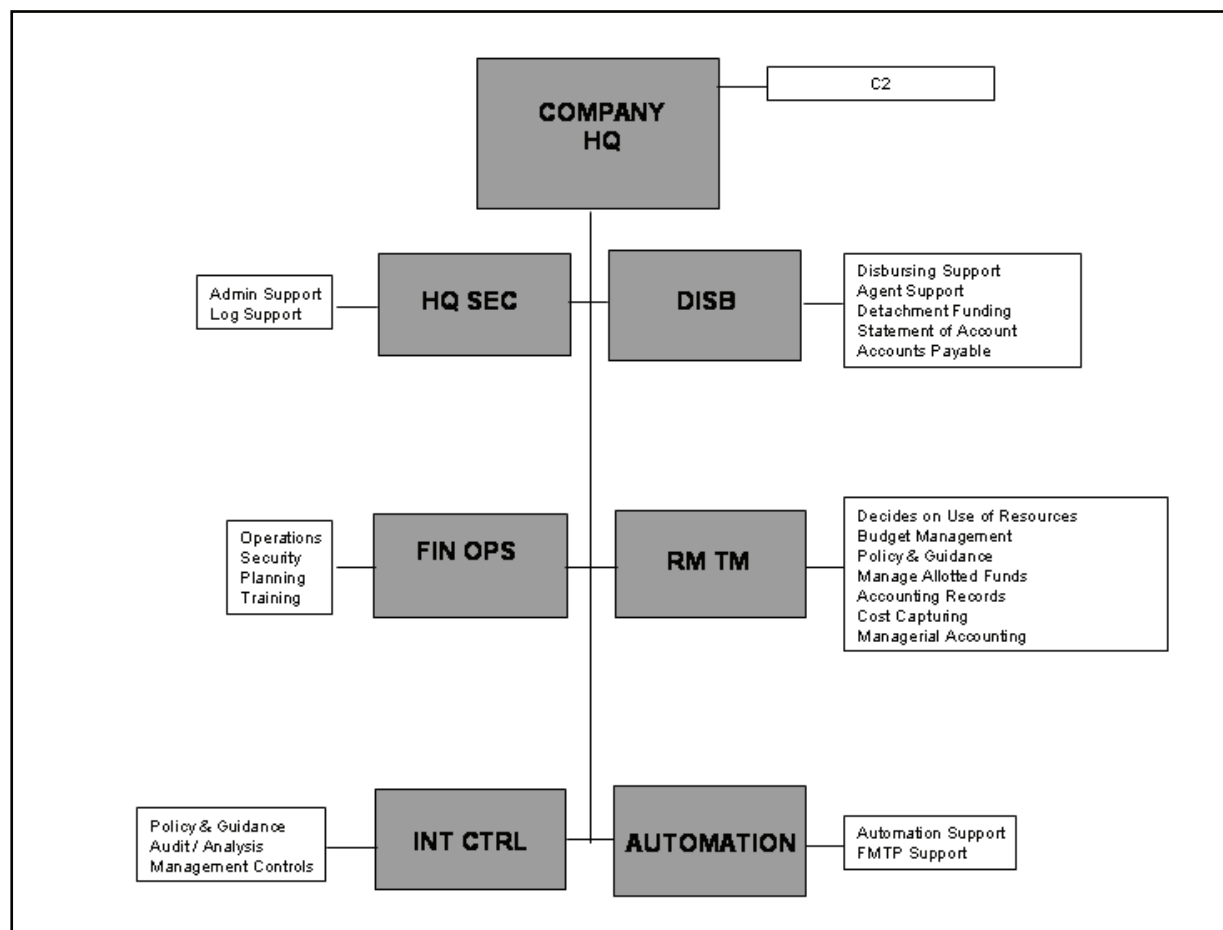

Figure 2-4. Financial Management Company (FM CO) Organizational Structure

FINANCIAL MANAGEMENT COMPANY (FM CO)

2-23. The FM CO exercises command and control of the company headquarters section and three to seven FM DETs. One FM CO is assigned to each Sustainment Brigade and/or one per three to seven FM DETs. The FM CO provides support on an area basis within an AO, to include support to joint and multinational commands, units, Soldiers, and authorized civilians and contractors. The theater FMC and G8 provide technical coordination to all FM COs within their AO.

Mission

2-24. The FM CO coordinates and executes financial management support on an area basis while providing critical information to the commander. The FM CO analyzes the supported commander's tasks and priorities to identify the financial resource requirements that will enable mission accomplishment. The FM CO is capable of augmenting other FM units to meet requirements at echelons above division and performs the following functions.

- Ensures regulatory guidelines, directives, and procedures are adhered to by all operational elements of the FM CO and subordinate FM DETs.
- Establishes DSSNs and LD accounts.
- Provides limited U.S. and non-U.S. pay support.
- Funds subordinate FM DETs and determines the need for currency (U.S. and foreign) and its replenishment.

Financial Management Organizational Structure, Roles, and Responsibilities

- Maintains regulatory accountable records.
- Evaluates, certifies and reports execution of funds.
- Provides EPW, CI and Local National pay support.
- Establishes banking relationships and procedures.
- Makes payments on prepared and certified vouchers.
- Receives collections.
- Receives and controls all currencies and precious metals.
- Cashes negotiable instruments.
- Converts foreign currency.
- Protects funds from fraud, waste, and abuse.
- Identifies funding for resource requirements including procurement, theater infrastructure construction, materiel, services for ports, communications, and transportation networks.
- Addresses fiscal issues associated with other Services, federal agencies, and nongovernmental organizations operating in the AO.
- Establishes a management control process providing reasonable assurance that government assets are protected and safeguarded.
- Ensures funds and other assets are protected, and revenues and expenditures are properly accounted for in accordance with congressionally mandated accounting and reporting requirements.
- Provides direct support to the Soldier Readiness Processing center.

Headquarters Section

2-25. The Headquarters Section provides and coordinates unit level administration, training, and sustainment support to the personnel of the FM CO and three to seven FM detachments. The section coordinates the deployment of FM CO personnel and equipment. Upon arrival at a new operational location, the section supervises the physical establishment of facilities for the FM CO, to include the CP. The FM CO must have sufficient transportation and communication assets to perform numerous and simultaneous support missions during day or night operations. The requirement to execute command and control increases the FM CO's need for adequate transportation, maintenance, communication, power generation, global positioning, and life support assets.

Finance Operations

2-26. Finance Operations coordinates the overall operation and readiness posture of the FM CO, provides financial policy and plans to the subordinate FM detachments, and provides unit status reports. The section coordinates all FM support within the FM CO AO and tracks missions conducted by FM detachments.

Resource Management (RM) Team

2-27. The RM Team is minimally staffed for execution of the resource management mission within the FM CO's AO. Better efficiency of these FM CO assets will be achieved by attachment to the Division or Corps G8. Consolidating all RM assets at the Division or Corps level will ensure proper analysis of the commander's tasks and priorities as they relate to financial and manpower resource requirements execution at the Corps, Division, and BCT/BDE levels.

Disbursing Section

2-28. The Disbursing section makes payments (cash, EFT, checks) on properly prepared and certified vouchers, receives collections, receives and controls all currencies, maintains accountable records, cashes negotiable instruments, makes foreign currency conversions, and determines the need for currency and its replenishment. The disbursing section also provides currency for assigned FM DETs.

Chapter 2

Internal Control (IC) Section

2-29. The IC section evaluates the effectiveness of existing procedures and internal controls, and ensures compliance with applicable regulations, directives and management controls.

Automation Section

2-30. The responsibility of the Automation Section is to support the information operations of the FM CO. The section coordinates the installation of software and hardware updates to the financial management tactical platform (FMTP). The section coordinates with the supporting signal unit for communications support and for external maintenance support. The section ensures system integrity against viruses and ensures appropriate systems security measures are in place.

FINANCIAL MANAGEMENT CONCEPT OF SUPPORT – CORPS AND/OR DIVISION

CORPS AND/OR DIVISION G8

2-31. The corps and/or division G8 provides the supported commander with mission essential funding when and where needed to ensure operational success, and protect funds from waste, fraud, and abuse. Depending upon METT-TC, augmentation may be required to support G8 operations. The division and/or corps G8 provides the following functions:

- Estimates, tracks, and reports costs for specific operations to support requests to the U.S. Congress for appropriation.
- Identifies and manages funds available for immediate expenses.
- Provides planning, programming, and budgeting support, budget analysis, management services, and force management support.
- Captures operations costs via standard accounting systems and the management of the operating systems that pay personnel and providers (contractors, host-nation, suppliers, etc).
- Provides advice to commanders on financial management implications and costs of preparing for and conducting operations.
- Tracks and reports costs of battlefield operations to support efforts of reimbursement of costs initially paid from available training and readiness funds.
- Obtains guidance on fund citations and funding levels and provides to tactical financial managers and supporting finance elements.
- Provides fund control, monitors fund execution, tracks and reports costs and obligations.
- Performs analysis, planning, administration, and control of human, fiscal, financial, material, and other DOD resources.
- Provides policy and fiscal guidance for Contingency Planning.
- Establishes the aggregate levels of fiscal support to be allocated and imposes directed resource constraints.
- Provides input to the program objective memorandums (POMs).
- Prepares budget schedules, adjusts budgets based on Program Budget Decisions (PBDs).
- Accounts for DOD real estate, equipment, supplies, personnel, other assets, and funds in accordance with established policy.

SUSTAINMENT BRIGADE FM SPO

2-32. The Sustainment Brigade FM Support Operations Team (FM SPO) monitors and tracks financial management operations throughout the area of operations (AO). The team integrates all FM operations; plans the employment of FM units; coordinates FM requirements; synchronizes the FM network and manages the FM systems. It also coordinates for additional operational and strategic FM support when

Financial Management Organizational Structure, Roles, and Responsibilities

needed. All functions of the FM SPO are closely coordinated with the FM CO commander and G8. Some of these functions include:

- **Integrate all FM operations within the AO.** The FM SPO evaluates the adequacy of support throughout the division by analyzing workload data, supporting population size, and scheduling of support at forward operating bases (FOBs); and making recommendations to maximize efficiency of limited resources throughout the supported AO. It monitors the use of cash or instruments representing cash on the battlefield to attain military objectives. The FM SPO oversees pay agent appointment and training for conventional and special program funds to ensure supported elements are prepared for pay agent missions.
- **Plan employment of FM units.** The FM SPO works with the FMC, G8 and FM COs to adapt FM support to changes on the battlefield.
- **Synchronize division FM network.** The FM SPO coordinates financial management efforts for the sustainment brigade across all supporting FM COs, contracting offices, and civil affairs units.
- **Manage all FM systems.** In coordination with FMC, G8 and FM CO, monitors the employment and update of finance systems used for disbursing, military pay, travel pay, vendor pay and resource management. Tasks may include coordination for assistance when systems go down, and scheduling system upgrades. Planning coordination would include coordinating communications support for expanding electronic banking initiatives.
- **Coordinate FM requirements.** In coordination with the FMC, G8 and FM CO, coordinate cash requirements for special funding sources such as CERP, for Soldier support (check cashing, casual pays), and vendor payments. Planning coordination is done with the sustainment brigade staff for emerging electronic initiatives (EFT payments or stored value card).
- **Coordinate operations and strategic FM support.** The FM SPO establishes mutually supporting flow of information among the FMC, G8 and the FM CO enabling responsive FM support on the battlefield.

FINANCIAL MANAGEMENT DETACHMENT (FM DET)

Mission

2-33. The financial management detachment's (FM DET) mission is to provide area FM support to a brigade combat team (BCT) or equivalent sized unit, or as directed by the financial management company (FM CO) commander. The FM DET provides timely and accurate payment for contractor and commercial vendor services support, disbursing and funding support, enemy prisoner of war (EPW) pay support, non-U.S. pay support and limited U.S. pay support. The FM DET must have sufficient transportation and communication assets to perform numerous and simultaneous support missions, and must be able to move day or night. Mobility is required to provide effective FM support for units over geographically dispersed locations on the battlefield. In addition, the requirement to conduct multiple and simultaneous support missions increases the requirement for a FM DET to have adequate transportation, maintenance, communication, global positioning, and life support assets. FM DETs are equipped with FMTP, which enables effective operations through the use of real time data and online capability. Figure 2-5 reflects the FM DET organizational structure.

2-34. The Financial Management Detachment is located throughout the battlefield, and is responsible for all financial management (FM) operations on an area basis. The FM DET performs the following functions:

- Commanding, controlling, and supervising widely dispersed, assigned, or attached financial management support teams (FMSTs).
- Performing procurement support.
- Performing disbursing operations:
 - Accountability for public funds.
 - Funding and processing of paying agents.

Chapter 2

- Currency exchange.
- Stored value card (SVC).
- Paper check conversion (PCC).
- Treasury check operations.
- Voucher payments.
- Exchanges for cash.
- Providing pay support.
 - Limited U.S. pay support.
 - Foreign national pay support.
 - EPW.
 - Travel.

Detachment Headquarters

2-35. The FM DET commander is directly responsible to the FM CO commander. The Detachment commander coordinates the deployment of FM DET personnel and equipment. When deployed away from the FM CO location, the commander coordinates with the supported headquarters to determine how and when the FM DET supports the overall base defense scheme and integrates the unit's base defense plan. Upon arrival at a new operational location, the FM DET commander supervises the physical establishment of facilities for the FM DET. The Detachment Sergeant coordinates administration, maintenance and logistical support.

Disbursing Section

2-36. The Disbursing Section provides currency to the FMSTs and Paying Agents, makes payments on properly prepared and certified vouchers, receives collections, receives and controls all currencies, cashes negotiable instruments, makes foreign currency exchanges, maintains accountable records, and determines currency requirements. The Disbursing Section augments the FM CO when collocated with the FM CO. The disbursing officer (DO) provides cash control and certifies payments. The disbursing manager is the deputy to the DO. When METT-TC dictates, the DO or deputy deploys with an FMST to provide leadership and technical expertise.

Financial Management Support Teams (FMST)

2-37. The FMST provides timely and accurate commercial vendor and contract payments, disbursing and funding support, EPW pay support, non-U.S. pay support and limited U.S. pay support to all units and Soldiers in their AO. The FM DET is designed with three FMSTs; two are designed to be more robust, with the required size and grade structure (staff sergeant) to deploy away from the detachment headquarters and operate independently. When METT-TC dictates, the FMST can be augmented with additional support from the detachment. The third FMST remains with the detachment headquarters, but can deploy as a mobile team when directed by the detachment commander. All accountable items are cleared through the disbursing section of the FM DET.

Financial Management Organizational Structure, Roles, and Responsibilities

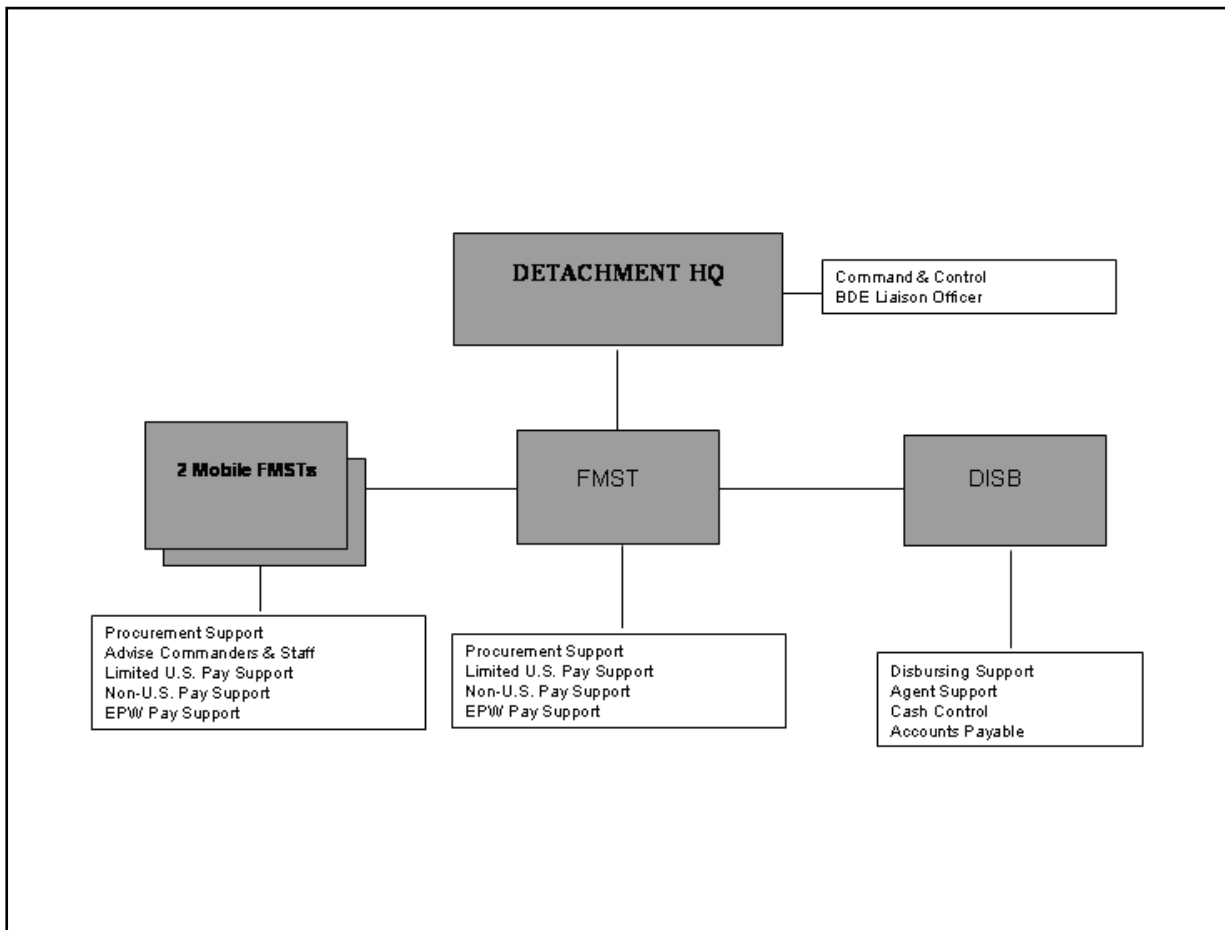

Figure 2-5. Financial Management Detachment (FM DET) Organizational Structure

This page intentionally left blank.

Chapter 3

Information Management

In today's information age, FM operations depend heavily on electronic information systems. Automating the battlefield and ensuring maximum efficiency of FM units involves planning, oversight, and execution of information operations. The processing and dissemination of timely and accurate FM information is critical to the success of Army missions worldwide.

FM units use commercial off the shelf automation coupled with advanced communications systems that are standardized, durable, survivable, and portable. Systems are easy to operate, compatible with different types of power sources, and able to operate in varying climatic and battlefield conditions. However, even with the ideal system, FM units are always prepared to resort to alternative processes in the event of major systems failures or insufficient automation infrastructure.

Unit commanders are responsible for information management within their units. The automation sections are responsible for executing information operations in the FM Center and the FM Company; in the FM DET, the information management officer, appointed as an additional duty, is responsible for information operations. Oversight of functional applications is the responsibility of the internal organizational functional proponent. All users of information are responsible for the integrity of data processed and the security of the supporting platforms. The automation sections have additional functional duties as described in chapter 2. Detailed information regarding the current state of automation and communications capabilities, equipment, and doctrine follow.

FINANCIAL MANAGEMENT TACTICAL PLATFORM CAPABILITIES AND CHARACTERISTICS

3-1. The AN/TYQ-132(V)1 and AN/TYG-132(V)2 financial management tactical platform (FMTP) systems are the FM automated systems for deployed operations (figure 3-1). There are two versions of FMTP. The basic version is composed of six client laptop workstations, one server laptop, three portable printers, and one multifunction printer. The expanded version is composed of eighteen client laptop workstations, one server laptop, six portable printers, three multifunction printers, and two high speed laser printers. In this section, FMTP refers to either or both systems. It is an integrated standard system using commercial off-the-shelf (COTS) hardware combined with commercial and government-developed software. Software modules include support for disbursing, resource management, vendor support, travel, and military pay. Software modules operate in a network environment, but they can also be used in a stand-alone environment detached from the file server. Although the specific software described in the following paragraphs may change, the capabilities provided to the commander will not change.

Chapter 3

Figure 3-1. Financial Management Tactical Platform (FMTP)

DISBURSING

3-2. The Deployable Disbursing System (DDS) provides automated disbursing support. The system provides the capability to write Treasury or LD checks, plus the daily accountability reconciliation for all transactions. DDS receives information from the commercial vendor support and travel modules, which allows the writing of checks to pay vendors and travel claimants. DDS creates Standard Finance System (STANFINS) formatted output for transmission to DFAS. DDS creates military pay vouchers and formatted output for upload to the military pay system for payment. The EFT interface in DDS requires an upload to FedLine (Federal Reserve Bank software) to place payments in the bank.

RESOURCE MANAGEMENT

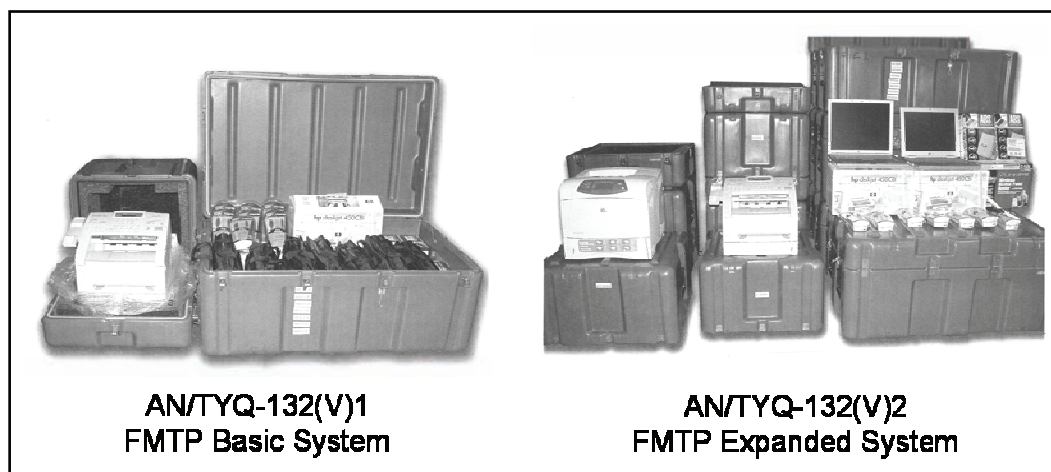
3-3. The Database Commitment Accounting System (dbCAS) provides RM support. This system provides for the input and tracking of all commitment and obligation information; dbCAS can receive downloaded STANFINS information to assist in matching commitments with obligations and disbursements. It also produces reports that allow the commander to determine current fund status.

VENDOR SUPPORT

3-4. The Computerized Accounts Payable System (CAPS) provides most commercial vendor payments. Input can be received electronically from the Standard Army Acquisition and Contract Network System (SAACONS) or manually based upon submitted contracts and invoices. CAPS produces vouchers for standard contracts and maintains the bills register for each contract, and interfaces with DDS to facilitate contract payments.

TRAVEL

3-5. The Integrated Automated Travel System (IATS) provides automated travel support. IATS provides the capability to process all types of travel payments (except civilian overseas permanent change of station (PCS) payments, which must be computed manually). IATS also maintains a travel record on every individual receiving a payment processed by that server, and interfaces with DDS to facilitate payments.

MILITARY PAY

3-6. The Defense Military Pay Office (DMO) software suite provides processing access to the military pay system to facilitate military pay support. This software is provided for all components (AC, NG and RC), in accordance with DFAS policies and procedures for contingency operations. Access to the military

pay databases provided by DFAS depends on the availability of dedicated communications. If online query capability is not available, a batch process DMO download provides near-time query capability. In addition, the DMO Standard Inquiry System (DSIS) provides the capability to download and archive pay data for an individual, or an entire unit, to facilitate offline pay support. The Evaluation and Reporting System (EARS) is a stand-alone system capable of providing various reports and files (for example, leave and earnings statements (LESS)), via DMO batch download.

COMMUNICATIONS

3-7. An FM unit's ability to provide timely and critical support depends greatly on its ability to communicate. Widely dispersed FM units must rely on communications with their headquarters to accomplish their mission. Although FM units use wire communications, they also need to possess and be able to utilize mobile and secure communications equipment. They must be able to use reach-back communications to range from forward in BCT areas, through division, corps or theater areas, to FM elements in distant supporting theaters, back to national providers in CONUS as shown in Figure 3-2.

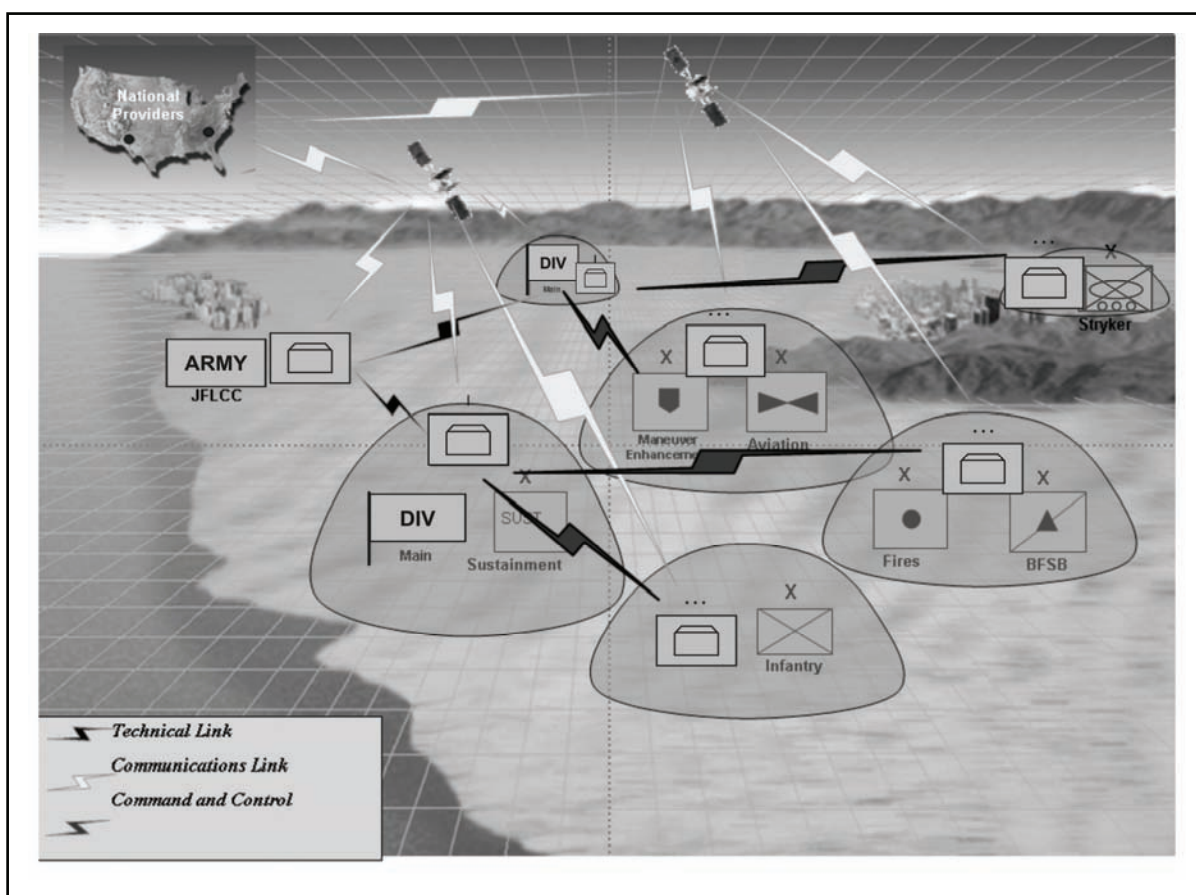

Figure 3-2. Financial Management Unit Communications

3-8. FM units use organic and non-organic voice and data transmission equipment to support internal fixed site, mobile base station, and mobile tactical communications requirements. The automation section coordinates external communications requirements through the higher FM units or supporting signal organization. The signal organization provides commercial or military communications assets, as available and appropriate to the requirement. The Combat Service Support Automated Information Systems Interface (CAISI) is the communications tool of choice for FM units.

3-9. FMTP is designed to utilize CAISI for its communications. CAISI is a logistics communications package designed and fielded by logisticians to facilitate Standard Army Management Information Systems

Chapter 3

computer systems' connections to the tactical network, and is being fielded to all FM units. With CAISI, commanders have instantaneous access to the most up-to-date FM information. CAISI provides an interface into tactical radio or satellite communications systems.

COMMUNICATION MODES

Satellite

3-10. Satellite communications are a common means of communication from the AO to the sustainment base component. Combat service support very small aperture terminal (CSS VSAT), the logistics satellite capability supporting CAISI, is the preferred method of connecting to a satellite network. CSS VSAT assets are located within the supporting Signal Brigade.

3-11. The Enhanced Position Location Reporting System (EPLRS) is a version of the Global Positioning System. EPLRS is the primary mode of transmitting data on the battlefield. Tactical FM units require EPLRS to conduct mobile operations. The EPLRS provides the capability of data transmission as well as team/unit location.

Wire

3-12. Wire is the primary means used for internal communications. Use of wire communications prevents hostile forces from using radio direction finding (RDF) equipment to locate the unit. Wire use is restricted mainly by mobility requirements, distance between users, installation and recovery time, and maintenance. Wire requires care in installation to preclude damage. Internal wire may be integrated with radio means to increase the capability of communications with outside units. Network radio interface (NRI) permits voice communications between radio users and telephone system subscribers, either from radio to telephone or vice versa, so long as the radio user is within range of the NRI station.

3-13. Mobile subscriber equipment (MSE) is a fully automated tactical area communications system, accessed via wire by FM units. It ensures mobile and static subscribers, regardless of location, can communicate via a nodal system throughout the battlefield.

3-14. MSE is designed to meet the requirements for a secure area switched system capable of supporting dispersed CPs. Using MSE, FM units have the ability to communicate with supported units, supporting units, deployed FM DETs and FMSTs, and other FM units.

3-15. Personnel may enter the MSE system via digital telephone or combat net radio. User-owned equipment may consist of digital nonsecure voice terminal (DNVT), facsimile terminal (FAX), or a secure mobile subscriber radio terminal (MSRT).

3-16. The DNVT is a telephone with a built-in data port used for non-secure voice and fax communications on the battlefield. Units are responsible for laying wire to connect the DNVT to a nearby junction box. Signal personnel then lay wire from the junction box to the signal-operated systems.

3-17. FAX terminals provide a rapid method of transmitting messages over wire or radio circuits. Messages are received and transmitted in the form of paper copy. The FAX provides high-speed, high-quality graphic communications. The terminal connects directly into the DNVT data port. The FAX can also send and receive text and graphic communications over wire. FAX capability is provided down to detachment and must be highly mobile and durable, given the operating environment and missions.

3-18. MSRT consists of a radio and secure telephone terminal with data interface capabilities. The MSRTs can be vehicular-mounted or can be set up within a shelter.

3-19. Theater signal units have the capability to provide unclassified data transmission capability out of the AO via MSE. Many of these units have the Network Encryption System (NES), which encrypts data and allows the data to be transmitted over the MSE network without the possibility of mixing classified and unclassified data. Data is uploaded from an unclassified system, through the NES, across the MSE network to another NES, which is routed to a satellite connection out of the AO.

Radio

3-20. An FM unit's communications cannot depend on wire communication only. Each FM unit must also use radio communications systems in lieu of and as a supplement to wire communications. Communications must be available at all times to accomplish various and concurrent missions. FM support is not static—radio communication must be available at all levels down to FMST to maintain constant communications with higher command levels as well as supported units. These communication requirements include data transmission as well as voice capability.

3-21. Radio systems are easier to use and quicker to install than wire, but are susceptible to detection by enemy RDF equipment, which can locate receivers and transmitters. The enemy can monitor transmissions, jam communications, or bring direct or indirect fire weapons to bear on the position of the transmitter/receiver.

3-22. FM units receive AN/VRC-90 radio sets, which are part of the single-channel ground and airborne radio system (SINCGARS). The SINCGARS is capable of processing voice, analog, and digital data in either the frequency hopping or single-channel mode, allowing the FM unit to communicate wirelessly with other FM units, and with supported units.

INTERNAL FIXED SITE COMMUNICATIONS

3-23. Various communications means are available to support fixed site operations at the tactical operations centers (TOCs) of FM units. Most communication requirements are met by using MSE, which can be set up in either permanent or temporary shelters. This equipment provides commanders with multiple means of communicating with outlying units. Headquarters elements send and receive financial and position-reporting data from subordinate units utilizing EPLRS when available.

BASE AND REMOTE SUPPORT OPERATIONS

3-24. FM units have the responsibility to provide support anywhere in the AO via mobile FMSTs. This requires a mobile capability and a means to locate and communicate with the FMSTs. The FMSTs transmit information via voice and data means. Communications modes necessary to support this mission include the MSRT or SINCGARS for voice, and EPLRS for data and position reporting.

TACTICAL OPERATIONS INTERFACE

3-25. Headquarters at all levels have access to MSE to pass command and control information across the AO. The appropriate automation section is responsible for coordinating this connectivity and for the maintenance of the node server, when required. Transfer of data from dispersed FM units to their next higher level occurs via the tactical network where capabilities permit.

COMMUNICATIONS SECURITY

3-26. Security of FM information is a high priority; safeguarding information is the responsibility of all FM personnel. Most electronic information systems and information networks are interconnected. Passwords and system protocols are highly valuable pieces of information that, if in the wrong hands, can cause the compromise of entire systems. Commanders must implement information security and communications security (COMSEC) policies and procedures to prevent hostile forces from accessing systems via the Internet or other means. FM systems are also subject to virus and worm infection. Commanders must ensure that proper measures are in place to protect against this threat.

3-27. Personnel engaged in preparing and transmitting messages, whether by telephone, radio, or messenger, must know and comply with all COMSEC procedures. COMSEC measures include physical, cryptographic, and transmission security. These procedures are included in AR 25-2, Information Assurance.

Chapter 3

SIGNAL OPERATING INSTRUCTIONS

3-28. FM units currently operate the automated net control device (ANCD), receiving necessary signal operating instructions (SOI) extracts from their parent headquarters. These extracts include information on major supported units in the AO.

COMMUNICATION NETWORKS

3-29. A communication network is an organization of stations capable of directly communicating with other users on a common frequency or channel. Financial management units communicate with each other primarily on the FM operations network. Financial management units may enter supported units' networks, such as the following:

- Command network.
- Operations and intelligence network.
- Administrative network.

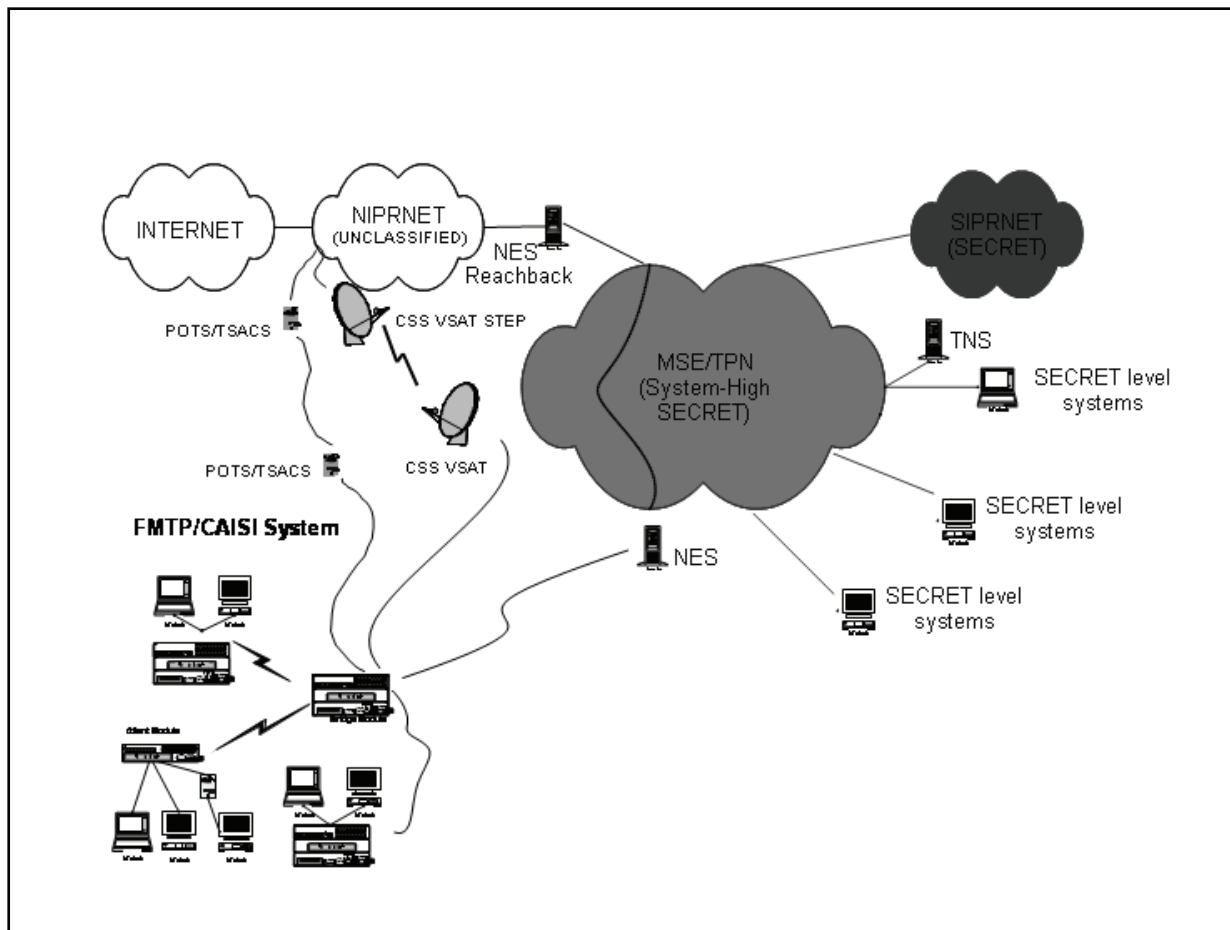

Figure 3-3. Financial Management Communications Networks

Command Network

3-30. The commander uses the command network for tactical control. Types of messages commonly passed over this network include orders, coordination, and information of immediate value.

Operations And Intelligence Network

3-31. Commanders and operations sections use the operations and intelligence network for command and control purposes. This network is used to control operations and pass intelligence information within commands. The network control station is located at higher headquarters. financial management support teams use this network when deployed from the parent FM DET. Unit automation sections disseminate specific procedures for use of this network.

Administrative Network

3-32. The administrative network is used for personnel matters and for supply information and requirements. S1s, S4s, and S6s at all levels of command use this network.

This page intentionally left blank.

Appendix A

Legal

This Appendix provides background on several important laws that provide the basis for FM operations. It is not meant to be all-inclusive or a source of legal guidance. Financial managers who have questions regarding the legality of payments should contact their local SJA for an advanced opinion.

Financial managers must use the principles of time, purpose, and amount (TPA). Time is to measure the appropriation life span (unexpired, expired, closed state). Purpose ensures expenditures meet the intent of the appropriation. Amount establishes the ceiling or floor for an appropriation.

FISCAL LAW

A-1. Fiscal law is of primary concern to financial managers. Failure to apply fiscal law principles properly may lead to unauthorized expenditures of funds and consequent administrative or criminal sanctions against those responsible. The authority to obligate U.S. Government funds is derived from Congress. The law of Federal appropriations has constitutional and statutory aspects that generally identify clear rules the GAO and other agencies apply to fiscal decisions. Once Congress has passed an appropriation and the President has signed it into law, agencies must request an apportionment from the Treasury Department within 10 days, and the Office of Management and Budget (OMB) must make apportionment within 30 days after signature. Once OMB apportions funds to the Department of Defense (DOD), the DOD subapportions funds to the military Services (including HQDA), USSOCOM, or Defense agencies to allocate to major commands. Major commands, in turn, allot funds to operating units. The apportionment process must be complete before funds can be committed.

A-2. Federal agencies require congressional appropriation to operate. In some cases, an authorization must also be enacted before an appropriation can be obligated. An appropriation is a law passed by a majority of members of the House and Senate, and signed by the President, that provides budget authority for the stated purposes. No other statutes and resolutions passed by Congress, including budget resolutions and authorization acts, authorize withdrawal of money from the U.S. Treasury.

A-3. Budget authority is the authorization to incur a legal obligation to pay a sum of money from the U.S. Treasury. Budget authority is not money; it is the authority to spend money that has been appropriated. The U.S. Treasury actually disburses cash only after an agency requests (or, in the case of the DOD, issues) an EFT or a check to withdraw money from the U.S. Treasury to liquidate an obligation.

A-4. DOD regulations mandate the use of commitment accounting for all appropriations, both unexpired and expired. Commitments are administrative reservations of funds, based upon firm procurement directives, orders, or requests, that authorize the creation of obligations without further approval by the official responsible for certifying the availability of funds. Issuing a commitment that authorizes an obligation in excess of an appropriation or formal subdivision of funds could result in a violation of the Antideficiency Act (see paragraph 3 of the Antideficiency Act).

A-5. Obligations are amounts of orders placed, contracts awarded, services received, or similar transactions made, that legally bind the U.S. Government to make payments. Congress has imposed fiscal controls that limit the ability of the Executive Branch to obligate and expend appropriated funds. Funds may be obligated only for the purposes for which they were appropriated; further, they may be used only to satisfy the bona fide needs of the fiscal year for which the appropriations are valid. A bona fide need is for payments or expenses properly incurred during the period of availability. In most cases, they may not be used beyond the period of availability. No one may obligate funds in excess of (or in advance of) an appropriation, an apportionment, or a formal subdivision of funds without specific statutory authority. If administrative lead-time requires contract award prior to the receipt of funds, contracts may be issued

Appendix A

“subject to the availability of funds” to ensure timely delivery of the goods or services. If this clause is used, no services or supplies may be accepted until after receipt of funds.

A-6. A corollary to the purpose and bona fide needs requirements regarding obligation of funds is the general prohibition against augmentation. The bona fide needs rule means current requirements must be funded with current dollars. Transfers from one appropriation to another are prohibited except as authorized by law. Appropriated funds designated for a general purpose may not be used to pay for an effort for which Congress has specifically appropriated other funds.

A-7. Continuing resolution authority (CRA) is an interim legislation enacted by Congress to provide authority to specific, ongoing activities when the normal fiscal year appropriation has not been enacted by the beginning of the fiscal year, pending the annual appropriation enactment by Congress. The CRA authorizes continuation of normal operations at a rate not to exceed the latest Congressional action or the previous year’s rate. The CRA does not authorize new starts or expansions to a program. A funding gap may occur in the absence of either an appropriations act or a CRA, or when the President vetoes a duly passed appropriations bill or continuing resolution following expiration of either of their predecessors. The Attorney General has determined that, absent an appropriation or a CRA, executive agencies must take immediate steps to cease normal operations. Disbursements supporting new fiscal year obligations may not be made during a funding gap unless specifically authorized by the Under Secretary of Defense (Comptroller) (USD(C)). The following excerpt from DFAS-IN Reg. 37-1 provides additional information on the CRA. The DFAS-IN Reg. 37-1 excerpt:

Definition: A CRA is an interim appropriation, enacted to provide authority for specific ongoing activities in the event that regular appropriations have not been enacted by the beginning of the fiscal year or the expiration of the previous CRA. A CRA has a fixed life and provides the authority necessary to allow operations to continue in the absence of appropriations.

Operations under a CRA. Unless the Office of the Secretary of Defense (OSD) issues other instructions, a CRA provides for the following:

A. Rate of execution generally will not exceed the amount contained in the President’s budget, the previous year’s rate of execution, or the amount recommended by the House and Senate Appropriations Committees, whichever is the lowest or most restrictive.

B. No new starts may be initiated. Operations and maintenance Army (OMA) appropriation funded minor construction is not considered a new start.

C. No increase in scope of ongoing programs is permitted.

D. No new multiyear procurements are permitted.

Operation in the Absence of Appropriations.

A. In the event that neither an Appropriation Act nor a CRA has been enacted, a “funding gap” exists.

B. Obligations may continue during the new fiscal year (FY) for minimum mission essential business.

C. Prior year unexpired funds of multi-year appropriations are not impacted by the absence of a new appropriation or a CRA. Revolving funds are also not impacted.

ANTIDEFICIENCY ACT

A-8. The Antideficiency Act is codified under sections 1341, 1342, 1344, and 1511-1517, title 31, United States Code (31 USC 1341, 1342, 1344, and 1511-1517) and is implemented by OMB Circular No. A-11, Part 4, DOD Directive 7200.1, and DOD 7000.14-R, Volume 14. It states that an officer or employee may

not make or authorize an obligation or expenditure that exceeds an amount available in an appropriation or formal subdivisions of funds. The GAO has determined that this statute prohibits obligations in excess of appropriated amounts and obligations that violate statutory restrictions or other limitations on obligations or spending. Officers or employees who authorize or make prohibited obligations or expenditures are subject to criminal sanctions and administrative discipline, including suspension without pay and removal from office. Good faith or mistake of fact does not relieve an individual from responsibility for a violation. Factors such as “a heavy workload at year end” or an employee’s “past exemplary record” generally are relevant only to determine the appropriate level of discipline, not to determine whether the commander should impose discipline.

LAW OF ARMED CONFLICT

A-9. The Law of Armed Conflict deals with a wide variety of areas, including monetary issues pertaining to prisoners of war. Actions regarding the treatment of prisoners of war, from what to do with money that prisoners of war are carrying to how much and when to pay them for their labor, are covered within the Law of Armed Conflict. *Additional information on payments to EPWs is contained in Appendix S.*

FEED AND FORAGE ACT

A-10. The Feed and Forage Act (41 USC 11 and 11a) permits the DOD to incur obligations in excess of or in advance of available appropriations to ensure necessary funding to support members of the Armed Forces of the United States conducting military operations. Clothing, subsistence, forage, fuel, quarters, transportation, and medical and hospital supplies, not in excess of the necessities of the current year, may be incurred at the direction of the Secretary of Defense. The USD(C) issues instructions to implement the order.

A-11. Although authority to act under the Feed and Forage Act is granted by the DOD, forward-deployed units must be prepared to request urgent obligation authority during contingency operations. Units will submit requests through command and/or resource management channels.

CHIEF FINANCIAL OFFICERS ACT OF 1990

A-12. The Chief Financial Officers Act of 1990 established a centralized FM structure within the OMB and in major departments and agencies. It strengthened FM internal controls by requiring the following:

- Preparation of 5-year FM systems improvement plans, both government-wide and in the 23 agencies covered by the act.
- Preparation of audited financial statements and audits of selected activities of agencies to hold agency heads accountable for their operations.
- Reporting to the President and Congress on the annual status of general and FM in the Federal government.

FEDERAL MANAGERS’ FINANCIAL INTEGRITY ACT — PUBLIC LAW 97-255

A-13. The Federal Managers’ Financial Integrity Act (Public Law 97-255) was enacted in September 1982 to strengthen internal control and accounting systems throughout the Federal government and to help reduce fraud, waste, and abuse, and misappropriation of Federal funds. The act holds agency managers accountable for correcting noted deficiencies and requires that agencies identify and report internal control and accounting system problems and planned remedies annually.

GOVERNMENT MANAGEMENT REFORM ACT OF 1994 AND THE FEDERAL FINANCIAL MANAGEMENT ACT OF 1994

A-14. The Government Management Reform Act and the Federal Financial Management Act (Public Law 103-356) were enacted to provide a more effective, efficient, and responsible government. These acts mandated statutory requirements for reports to Congress, the use of EFTs for payments, the establishment

Appendix A

of a franchise fund in each of four executive agencies, and the submission of annual audited financial statements to the Director of the OMB.

31 USC

A-15. Title 31 of the U.S. Code contains the basic statutory requirements for the use, control, and accounting of public funds.

31 USC 1301 (THE PURPOSE STATUTE)

A-16. Title, 31, Section 1301 of the U.S. Code (31 USC 1301) (The Purpose Statute) imposes the requirement that agencies use appropriated funds only for their intended purpose.

Appendix B

Financial Management Deployment Checklist

The following is a checklist of FM related activities that the financial manager should consider in planning and executing operations. Activities are not necessarily limited to a single phase. This checklist is not all inclusive.

MOBILIZATION AND PRE-DEPLOYMENT OPERATIONS

RESOURCE MANAGEMENT OPERATIONS

B-1. As part of resource management (RM) operations in mobilization and pre-deployment, the financial manager should—

- Deploy as a member of the Pre-Deployment Site Survey (PDSS) Team.
- Provide RM advice and assistance to command and staff.
- Determine RM specified, implied, and essential tasks for unit(s) and agencies to accomplish the mission.
- Determine unit preparation, packing, and crating costs.
- Determine method of deployment/redeployment and begin initial coordination with the transportation officer.
- Develop cost capturing methods, APCs, FCA, fund cite, Unit Level Logistics System (ULLS) data entry with G4/material management center (MMC).
- Analyze all support agreements for RM implications.
- Ensure the lead Service has been designated, when appropriate.
- Maintain an awareness of costs; participate in the staff estimate and planning process.
- Prepare the FM Appendix of the unit OPORD and review OPLANs, to include the concept of support.
- Review requirements for RM support and establishment of funding responsibility, to include contracting and procurement; ensure the mechanism for cost capturing is established.
- Establish and identify resourcing processes and approval authorities for requirement development, validation and funding (all levels, BCT – ASCC).
- Review interagency financial support agreements.
- Determine if support is required for other agencies, such as morale, welfare, and recreation (MWR), the American Red Cross, NGOs, and public affairs (PA).
- In coordination with the G4, determine availability of HNS, coalition, and/or AIK support, and establish reporting and reimbursement requirements. In coordination with the G4 and staff engineer, initiate wartime military construction requests or reprogramming action.
- Determine any unique reimbursement procedures, if necessary, to capture incremental costs.
- Request special appropriations, if required.
- Identify and understand the various appropriations, authorities, and agreements associated with deployment.
- Implement procedures to track multinational support costs and review billing procedures.
- Review cost estimates, when required.
- Coordinate with the SJA to ensure legal considerations are reviewed.
- Provide fund certification.

Appendix B

- Determine the commitment accounting automation plan.
- Identify fiscal year-end closeout plan.
- Identify and determine management control requirements.

FINANCE OPERATIONS

- B-2. As part of finance operations in mobilization and pre-deployment, the financial manager should—
- Prepare the finance portion of the FM Appendix of the unit OPOD and review OPLANS to develop the concept of support.
 - Consolidate and analyze the economic assessment for the AO.
 - Provide financial advice and assistance.
 - Determine if foreign currencies are to be used and their exchange rates.
 - Develop requirements for check cashing; emergency payments; currency conversion; funding of paying agents; foreign currency conversion; solatium payments; recording of cost data, travel, civilian pay and funds disbursement.
 - Determine what duty conditions have been designated for the operation by the commander.
 - Determine if group travel has been declared.
 - Coordinate entitlements, if required, for Reserve Component (RC) participation.
 - Coordinate with the G1 to ensure consistency of entitlements and level of support. If required, request determination of hostile fire pay, imminent danger pay, hardship duty pay, family separation allowance, special leave accrual, and combat zone tax exclusion.
 - Publish guidance, when required, on UN entitlements, leave, and observers to peacekeeping organizations.
 - Determine appropriate check cashing limits and recommend approval by the commander.
 - Coordinate with the DFAS crisis coordination center.
 - Determine accounting and central funding support needed for the operation.
 - Determine banking support requirements.
 - Determine appropriate quantities of foreign currencies and formalize resupply procedures.
 - Support NEO.
 - Prepare to provide currency funding support to other U.S. and allied organizations in the AO.
 - Determine the requirement for LDAs.
 - Prepare for solatium payments and payments for other claims.
 - Coordinate with the SJA to ensure legal considerations are reviewed.

DEPLOYMENT AND FULL SPECTRUM OPERATIONS**RESOURCE MANAGEMENT OPERATIONS**

- B-3. As part of RM operations in deployment and full spectrum operations, the financial manager should—
- Co-locate and conduct RM operations with logistic, contract, and disbursing/paying agent assets.
 - Coordinate RM aspects of HNS and AIK.
 - Plan for handling battlefield effects and identify the funding source for anticipated requirements.
 - Capture and track costs.
 - Provide reports as required, including those needed for reimbursement by a HN, a foreign nation, NGOs, or other Federal agencies.
 - Coordinate with the SJA (co-locate if possible) to ensure that legal considerations are reviewed.
 - Provide fund certification.
 - Establish and monitor commitment accounting automation system(s).
 - Monitor established management controls.

FINANCE OPERATIONS

B-4. As part of finance operations in deployment and full spectrum operations, the financial manager should—

- Perform central funding and accounting (both appropriated and nonappropriated) support, if necessary.
- Support contracting and local procurement requirements.
- Control currency.
- Provide EPW and/or CI pay support, if necessary.
- Support NEO, if necessary.
- Provide limited pay support to joint and multinational forces, as well as designated civilians.
- Coordinate with the SJA to ensure legal considerations are reviewed.

STABILITY OPERATIONS**RESOURCE MANAGEMENT OPERATIONS**

B-5. As part of RM operations in stability operations, the financial manager should—

- Identify and request additional sources of funds (by FY, if needed) in order to continue sustainment of the operation.
- Enforce and adjust resourcing processes and approval authorities for requirement development, validation and funding (all levels, BCT – ASCC).
- Continue to capture and track costs.
- Determine requirements, when necessary, for civil assistance funding.
- Coordinate with the SJA to ensure that legal considerations are reviewed.
- Provide fund certification.
- Monitor the commitment accounting automation system.
- Prepare for year-end closeout, if necessary.
- Prepare for internal and external audits.
- Monitor established management controls.

FINANCE OPERATIONS

B-6. As part of finance operations in stability operations, the financial manager should—

- Provide banking and currency support.
- Provide pay support to joint and multinational forces, as well as designated civilians.
- Provide CVS support.
- Establish pay support procedures for the remaining forces in-theater.
- Coordinate with the SJA to ensure that legal considerations are reviewed.

REDEPLOYMENT AND DEMOBILIZATION OPERATIONS**RESOURCE MANAGEMENT OPERATIONS**

B-7. During redeployment and demobilization operations, the financial manager should—

- Coordinate and develop RM requirements for redeployment support.
- Close out contingency funding operations and conduct hand-off procedures with the responsible component.
- Coordinate cost capturing for recovery operations.
- Provide fund certification.
- Seek reimbursement for cost offset or incremental costs.

Appendix B

- Submit final cost report.
- Submit after action review.

FINANCE OPERATIONS

B-8. As part of finance operations in redeployment and demobilization operations, the financial manager should—

- Close out the accounts of paying agents.
- Ensure Service Members' deployment related entitlements are stopped.
- Audit pay accounts.
- Close contingency disbursing station symbol numbers (DSSNs).
- Convert from contingency accounting processing codes (APCs) back to home station APCs.
- Request additional obligation authority to replace or repair damaged or destroyed equipment.

Appendix C

Guide to Operation Plan Development

This Appendix provides an administrative guide, instructions, and format for developing the FM Appendix to the logistics annex of an operation plan (OPLAN).

PROCEDURES

C-1. The FM Appendix to the logistics annex of the OPLAN is developed in conjunction with—and in support of—the running estimate and operational planning process. The FM Appendix identifies and resolves FM support problems and funding responsibilities in advance of plan implementation. Command responsibilities and functional alignments for providing FM support should be described and defined in the Appendix in sufficient detail to ensure that provisions are made to support all mission essential tasks.

Note: Providing entitlement information to financial managers and DFAS is critical to ensuring accurate payment of personnel deploying to support joint force operations; hence, the information should be communicated as soon as possible.

CLASSIFICATION	
HEADQUARTERS	
	Date
Appendix X (Financial Management) to Annex X (Logistics) to OPLAN	
REFERENCES: Cite the documents necessary for a complete understanding of this Appendix.	
1. Situation	
<ul style="list-style-type: none"> a. Purpose. This Appendix provides broad policy and procedural guidance and assigns tasks for FM operations. This Appendix describes the mission and responsibility of FM units during deployment and sustainment for both the joint headquarters and components within the AO. b. Enemy. Refer to Annex X, Intelligence. Assess the impact of enemy capabilities and probable COAs on FM support. c. Friendly. List the component FM organizations and the specific tasks each is assigned to support the FM operations of the plan. Summarize their capabilities. Include non-U.S. military forces and U.S. civilian agencies, such as banking institutions or embassies, which may help assigned forces provide FM support (or may themselves require support). d. Assumptions. State realistic assumptions and consider the effect of current operations on FM operations. These could be similar assumptions used by the components when developing cost estimates for the operation. e. Limitations. List key limiting factors that affect FM capabilities. 	
2. Mission. Describe the FM mission in support of the basic plan in a clear concise statement.	

Appendix C

3. Execution.

a. **Concept of Operations.** Summarize the intended COA and state the general concept for FM support in the operational area. In separate numbered subparagraphs, provide specific guidance on the following, as applicable:

(1) **Pre-Deployment and Mobilization Operations**

- (a) Ensure the lead service has been appointed, when required.
- (b) Obtain and analyze available economic assessment data of the operational area and any financial implications.
- (c) Analyze all support agreements.
- (d) Identify missions requiring special funding and authority, when required.
- (e) Determine if foreign currencies are to be used and, if necessary, determine the exchange rates.
- (f) Coordinate entitlement policies with the C1, G1, and S1, as appropriate, prior to deployment.
- (g) Establish joint and combined FM operational requirements, to include disbursing support, contracting support, commercial vendor payment support, and any other unique FM requirements.
- (h) Coordinate the establishment of HN-limited depositories account.
- (i) Determine if support is required for other organizations, such as MWR, the American Red Cross, NGOs, and PA.

(2) **Deployment and Full Spectrum Operations.**

- (a) Support contracting and local procurement requirements.
- (b) Provide reports as required.
- (c) Provide policy guidance, if necessary, for EPW and/or CI, NEO, MWR, the American Red Cross, NGOs, and PA.
- (d) Obtain MWR funds, if required.
- (e) Identify and task component(s) for continued FM support, if required.
- (f) Ensure a management control process is in place.

(3) **Redeployment and Demobilization Operations.**

- (a) Identify, when necessary, funding requirements for redeployment support.
- (b) Close out contingency funding operations and conduct hand-off with responsible component.

b. **Assignment of Tasks.** In separate numbered subparagraphs, address unique tasks required of the components to accomplish the FM mission.

c. **Coordinating Instructions.** This subparagraph will include, but is not limited to the following:

- (1) Items common to two or more subordinate commands and any unique FM relationships.
- (2) Coordination with adjacent commands and other agencies.
- (3) Agreements with the host country, allied forces, and U.S. Government and nongovernmental agencies.
- (4) DFAS crisis coordination center responsibilities.

4. **Administration and Logistics.** Provide FM guidance for furnishing logistics and administrative support. As appropriate, include guidance on the following:

- a. Contracting requirements.
- b. Logistic support relationships.

- c. Reporting requirements.
 - d. Any particular personnel or augmentation requirements.
 - e. Time frame after which all FM plans and budgets can be declassified (determined by coordinating with the J2, C2, G2, or S2, as appropriate).
5. **Command and Control.** Include the following information:
- a. Command relationships.
 - b. Communications systems requirements for FM support.

This page intentionally left blank.

Appendix D

Paying Agents

This Appendix provides guidance to paying agents who serve as agents for and in the name of an account holder. Commissioned officers, warrant officers, enlisted members, or civilian employees satisfactory to the appointing officer may be appointed as paying agents (see DOD 7000.14-R, volume 5). The guidance provided in this Appendix emphasizes the agent's responsibility for properly safeguarding and disbursing public currency. Paying agents are appointed to perform specific duties: they are appointed either to support the local procurement process, or to provide support to individuals. Paying agents cannot perform both of these duties simultaneously.

METHOD OF APPOINTMENT

D-1. A paying agent is appointed by a field grade commander in the paying agent's chain of command. The appointment order specifies the FM commander to whom the agent is appointed, the types of payments to be made, the unit to be paid, the duration of appointment, and the maximum amount to be advanced. A sample appointment order is shown in figure D-1.

D-2. The paying agent checks the appointment order for correctness and keeps it in his possession while performing duties as a paying agent. The paying agent forwards a copy of the appointment order to the FM commander to which the paying agent is appointed. The FM commander keeps a copy of the appointment order until the order expires or is revoked.

D-3. Newly appointed paying agents must immediately contact the nearest FM unit to receive a detailed briefing before they are advanced currency. Paying agents must receive a copy of the current paying agent instructions from the FM commander and become thoroughly familiar with all responsibilities. Paying agents sign a written statement for permanent filing with the disbursing officer, acknowledging understanding and receipt of the oral and written instructions.

Appendix D

OFFICE SYMBOL	DATE
<p>MEMORANDUM FOR (1) SUBJECT: Appointment as Paying Agent</p> <p>1. Effective (2) , you are appointed as a Paying agent to (3) , Commander, 82d FM CO. The maximum amount you can be advanced is \$ (4).</p> <p>2. Authority: DOD 7000.14-R, volume 5, paragraph 020604.</p> <p>3. Purpose: To make \$50.00 Soldier combat payments for (unit).</p> <p>4. Period: (5).</p> <p>5. Special instructions: You will not entrust or advance your currency advance to others for any purpose or reason. You will familiarize yourself with FM 1-06 (14-100), especially Appendix D, Paying Agents. Upon receipt of the FM commander's instructions, you will read and discuss them with FM personnel so that you fully understand your responsibilities and liabilities before you depart the financial management unit. You will at all times properly protect your currency advance and paid vouchers as outlined in your instructions and IAW DOD 7000.14-R, volume 5. You will properly identify all individuals you pay. You will immediately notify the finance commander of any discrepancies as soon as detected. You will turn in currency and paid vouchers to the financial management unit immediately upon completion of your mission. (6)</p> <p style="text-align: right;">XXXXXXXXXXXXXXXXXX LTC, IN Commanding (7)</p> <p>CF: Commander 82d FM CO Commander, C Co, 1st BN BN S-1</p>	
<p>Notes:</p> <p>(1) Agent (grade, name, SSN, unit).</p> <p>(2) Effective date of appointment order.</p> <p>(3) FM commander to whom agent appointed.</p> <p>(4) The total amount necessary to complete the mission.</p> <p>(5) Specified period of appointment.</p> <p>(6) Any specified instructions deemed appropriate.</p> <p>(7) Agent's commander or individual authorized to sign for commander.</p>	

Figure D-1. Sample Appointment Order

COMMANDER RESPONSIBILITIES

D-4. Commanders appoint paying agents and ensure the agents know their responsibilities and duties. In addition, unit commanders provide resources such as transportation, security containers, weapons, ammunition, and armed guards for the paying agent's use. The type of transportation and the number of guards considered adequate are based upon the amount of currency involved, the distance and terrain to be covered, and the overall security of the area where payments will be made. An agent should be armed (if

possible) and must have at least one armed guard. Commanders ensure other duties assigned to a paying agent do not interfere with or delay the performance of the agent's paying functions.

FM COMMANDER'S RESPONSIBILITIES

D-5. The FM commander or his designee briefs new paying agents to inform them of their responsibilities. He also gives the paying agents detailed written instructions regarding the specific functions they are to perform, procedures for the safeguarding and expeditious return of currency, and other instructions deemed necessary.

SAFEGUARDING PUBLIC CURRENCY

D-6. Paying agents must acknowledge receiving currency by signing DD Form 1081, Statement of Agent Officer's Account. The safeguarding of this currency is a personal responsibility of the paying agent until the currency is returned to the FM unit. Failure to safeguard currency may result in an agent being held personally liable if any currency is lost. A paying agent may not entrust currency or accountable instruments to any other person for any reason.

D-7. The paying agent must make every effort to complete all payments and return currency and payment documents as quickly as possible. If possible, the agent should return the currency and receipts on the same day the currency was advanced, or as the FM commander directs.

D-8. If currency is to be retained overnight, the agent must abide by the guidelines found in DOD 7000.14-R, Volume 5, Chapter 3, Keeping and Safeguarding Public Funds. If these provisions cannot be met, the agent must turn in the currency and paid documents to the FM unit for safekeeping. The agent must arrange to receive the currency the following day. The agent must return all currency to the FM unit upon accomplishing the mission.

D-9. Paying agents are directly responsible to the FM commander from whom the currency is obtained. The U.S. Treasury may legally look to either the FM commander or the paying agent to recover any lost or improperly disbursed public currency. Therefore, a paying agent must not—

- Use entrusted currency for any purpose other than that which is specifically stated on the appointment orders.
- Lend, use, convert to his own use, deposit in any bank, or exchange for other currency, or commingle any portion of the entrusted currency, except as specifically instructed by the FM commander.
- Mix entrusted currency with personal, nonappropriated, or other currency.
- Act as witnessing officer of payments.
- Be designated as the agent of another agent.
- Act as guard for another agent.
- Act as both the ordering officer and paying agent.
- Authorize solatium payments.

TYPES OF SUPPORT

D-10. Paying agents provide both local procurement support and individual support. Local procurement support involves the purchase of supplies and services from the local economy in order to meet logistical shortfalls. Individual support entails making payments, cashing checks, and making foreign currency conversions for individual Service Members.

LOCAL PROCUREMENT SUPPORT

D-11. For local procurement support, the commander appoints a paying agent on an additional duty appointment order. This appointment authorizes the paying agent to disburse public currency IAW the special instructions stated in the appointment and the written instructions provided by the FM commander. The ordering officer whom the paying agent supports receives separate instructions from contracting

Appendix D

officials. The paying agent provides support only for local procurement efforts; the paying agent does not provide any individual support.

D-12. In some cases bulk funding may be more practical than use of a separate fund cite for every purchase, especially in the early stages of an operation, to support advanced echelon (ADVON) or for widely dispersed units. Typically a DA 3953 is used to provide the bulk funding.

D-13. The paying agent or ordering officer may be held personally liable for any payment not in accordance with the appointment orders or prescribed instructions. The paying agent cannot simultaneously serve as the ordering officer. The paying agent uses an official credit/debit card to make payments whenever possible. When it is not possible to use an official credit/debit card to make payments, the paying agent takes the following actions:

- Reviews all SF 44s (U.S. Government Purchase Order–Invoice–Voucher) prepared by the ordering officer.
- Disburses currency for the goods or services as stated on the SF 44 (Purchase Order-Invoice-Voucher), but only after the SF 44 has been approved by an ordering officer.
- Pays for single voucher purchases not to exceed \$2,500 per voucher. (An agent may not split purchases between two or more vouchers in order to circumvent the \$2,500 limitation.)
- Clears his account with the FM commander.

D-14. When reviewing the SF 44s, the paying agent ensures the blocks of information listed in Table D-1 are completed properly.

Table D-1. Instructions for Completing SF 44		
Item	Block Title	Instructions
(1)	Date of orders	Enter date prepared.
(2)	Order number	The number identifying the purchase transaction will be in sequence.
(3)	Print Name and Address of Seller	Enter seller's name and address.
(4)	Furnish Supplies and Services to	Enter name and address of unit.
(5)	Supplies or Services	Individually list items ordered with proper identification numbers. Use additional SF 44s as continuation sheets if more space is needed to list all items ordered.
(6)	Quantity, Unit, Price, Amount	Self-explanatory.
(7)	Discount Terms	Negotiate for a Government trade discount and for prompt payment; insert the information on SF 44s.
(8)	Date Invoice Received	Not used.
(9)	Agency Name and Billing Address	Put "Department of the Army," then financial management unit and mailing address.
(10)	Ordered by	Enter signature and title of ordering officer.
(11)	Purpose and Accounting Data	Enter project reference and correct accounting classification.
(12)	Received by, Title, Date	Only the individual authorized to receive service or supplies will sign in the block titled "Received by" on copies 3 and 4. (Ordering officers cannot sign for receipt.)
(13)	All remaining items under Seller	The remaining items are completed by seller and deputy/agent.

**U. S. GOVERNMENT
PURCHASE ORDER-INVOICE-VOUCHER**

DATE OF ORDER 11 June ***(1)		ORDER NO. DAFD01-***M-0458 (2)	
BUYER NAME AND ADDRESS OF SELLER (Please use, Street, City, and State)* BIG SARGES SUPPLY DEPOT, INC. 1212 SOLDIER DRIVE ANYTOWN, GA 31418 (3)			
PROPERTY SUPPLIER OR SERVICE TO (Please use address) U.S. ARMY RESERVE CENTER FORT STEWART, GA 31314 (4)			
QUANTITY OR MEASURE		QUANTITY	UNIT PRICE
Field Safes, Standard (5)		2 (6)	493.45
Cash Box		2	34.50
			69.00
RECEIVED IN OPLOC ACCOUNTS PAYABLE 12 JUN ***			
Payment Due Date:			
AGENCY NAME AND BILLING ADDRESS OPERATING LOCATION ATTN: ACCOUNTS PAYABLE (9) FORT STEWART, GA 31314		TOTAL \$1,055.90 DISCOUNT TERMS NET N % 30days (7) DATE INVOICE RECEIVED (8)	
ORDERED BY (Signature and title) C.M. BECKTON C.M. BECKTON, MAJ, IN (10)			
PURPOSE AND ACCOUNTING DATA 21*2020 76-9505 111011.00 - 26EB SDRN/A111 S09076 (11)			
RECEIVED BY J. Monroe (12)			
TITLE (OFF. AG ASSISTANT) MOTORPOOL CHIEF			DATE 11 June **
PAYMENT RECEIVED <input type="checkbox"/> PAYMENT RECEIVED <input checked="" type="checkbox"/> PAYMENT REQUESTED			
NO FURTHER INVOICE NEED BE SUBMITTED			
SELLER BY: _____		REMARKS	
I certify that this amount is correct and proper due payment to the amount of _____		DIFFERENCE	
(unbalanced check, log address)		AMOUNT VERIFIED: CORRECT FOR	
PAID BY CASH		DATE PAID	VOUCHER NO.
DN _____			

* PLEASE FOLDER 1. SELLER'S INVOICE STANDARD FORM 64 (Rev. 10-63) PRESCRIBED BY GSA FPMR (41CFR) 101-11.6

Figure D-2. Sample SF 44

Appendix D

INDIVIDUAL SUPPORT

D-15. For individual support, the commander appoints a paying agent on an additional duty appointment order. This appointment authorizes the paying agent to disburse public currency IAW the special instructions stated in the appointment and the written instructions provided by the FM commander. When appointed to provide individual support, the paying agent provides only individual support; he does not provide local procurement support. As directed, agents may provide individual support to Soldiers, Sailors, Airmen, Marines, and authorized civilians.

PLANNING FOR SUPPORT

D-16. The paying agent ensures arrangements for qualified armed guards and transportation are adequate. Routes and times should be changed frequently to avoid developing routines and patterns in transporting currency. Prior coordination should be made for preparing the pay area with tables, chairs, lighting, and other necessary supplies. Emphasis is placed on acquiring a secure or easily secured quiet area. For efficient use of time, a schedule for payment of units or individuals should be established.

D-17. A paying agent takes appropriate precautions while currency is in his possession. When traveling, the paying agent should keep the unit informed of his location and expected time of arrival. If the paying agent is to travel outside the normal pay area, he should notify the FM commander.

D-18. A paying agent engaged in the paying function may not perform collections or solicitations for donations. If authorized, these activities must be performed separately and away from the pay area.

INDIVIDUAL SUPPORT FUNCTIONS

D-19. The following paragraphs describe additional paying agent functions.

RECEIVING CURRENCY

D-20. A paying agent is told when and where currency is to be made available. The agent reports as scheduled and has the following items:

- Military identification card.
- Copy of appointment orders.
- Weapon and ammunition (as applicable).
- At least one armed guard.
- Military vehicle.

D-21. After verifying the agent's identity, the FM commander or authorized deputy advances currency to the agent. Currency amounts are recorded on DD Form 1081, which is signed by the FM commander or authorized deputy and the paying agent. The agent counts the money received in the presence of the FM commander or authorized representative to ensure the amount is accurately recorded on the DD Form 1081. Money bands (currency straps or bill wrappers) on currency may not be destroyed until verification has been made. The money bands identify the activity and individual preparing each bundle. The agent must verify all items.

D-22. The FM commander is notified immediately of any discrepancy in either cash or checks received. The FM commander reconciles any discrepancies. Under no circumstances may the agent leave the FM unit until he is completely satisfied that the amount of cash received agrees with the amount shown on the DD Form 1081.

D-23. Upon leaving the FM unit, the agent and guard go directly to the pay site. Upon arriving at the pay site, the paying agent establishes security measures.

D-24. The paying agent negotiates only one payment at a time. After the agent identifies the payee, obtains the payee's signature, and secures the signed instrument, payment is made. Special attention must be given to first names, middle initials, and Social Security numbers. The paying agent must count out the amount of currency required for the payment, the payment is counted again in full, count it to the payee during

payment, and then have the payee count it to verify accuracy. Unsigned instruments, monies, and signed instruments are returned to the FM commander after all reasonable attempts to pay the individuals have been made.

CASHING U.S. TREASURY CHECKS AND OTHER NEGOTIABLE INSTRUMENTS

D-25. Cashing U.S. Treasury checks and other negotiable instruments involves an exchange of U.S. currency for a Treasury check. The paying agent obtains currency from the FM unit and goes directly to the pay area. The number of individuals cashing these checks varies.

D-26. Sufficient currency is advanced to the agent to meet anticipated requirements based upon an experience factor developed by FM personnel. Because the amount of currency needed to cash Treasury checks cannot be determined in advance, the paying agent must consider cash availability when presented with a Treasury check. The paying agent then follows established procedures for obtaining identification and signature on the reverse (back) of each check.

D-27. The agent then secures the check and pays the Soldier using the following three-count system. First, the agent counts the amount of currency required to pay a single Treasury check from the cash box; once all bills are out of the drawer/box, the payment is counted again in full (second count); he then counts the sum again to the payee during payment (third count); the payee then counts the currency to verify for accuracy before leaving the pay point. The agent then returns the payee's ID card. Payment in this manner provides a reliable three-count system resulting in accurate payments. After the agent completes the payments, he returns all signed checks and remaining currency to the FM unit.

D-28. Appointment orders indicate the types of negotiable instruments the paying agent is authorized to cash. Authorization for paying agents to cash personal checks, traveler's checks, U.S. postal money orders, cashier/official checks, credit union share drafts, and telegraphic money orders are obtained from the FM commander prior to negotiating the instrument.

D-29. The FM commanders provide paying agents with a written notice to inform individuals cashing personal checks that checks returned for any reason will result in immediate collection from their pay account. This notice must be posted at the paying location.

EXCHANGING CURRENCY

D-30. The paying agent receives an advance of foreign currency to exchange for U.S. currency. The foreign currency is exchanged at the same rate at which the foreign currency was advanced to the agent on a DD Form 1081. Normally, even increments of money (multiples of \$5) are exchanged to promote accuracy and to make the process as quick as possible. The paying agent will receive additional specific instructions from the FM commander.

D-31. Complete changeouts from one currency to another may be required. The FMC Chief promulgates specific policy and procedures should a changeout become necessary.

IDENTIFICATION OF THE PAYEE

D-32. The agent must not make a payment until the payee has provided positive identification in the form of an official U.S. Armed Forces ID card. Identification by other means (DOD civilians, dependent, or foreign national ID cards) may be authorized by the responsible FM commander. Payment is authorized to the payee only. Presentation of a power of attorney is not acceptable for payment. Doubtful cases are always referred to the FM commander.

SIGNATURE OF THE PAYEE

D-33. After making positive identification, the paying agent obtains a proper signature before payment is made. The payee's signature on the document or the payee's electronic signature is the only physical proof that payment was made. Before payment is made, the document must be signed or the electronic signature annotated in the presence of the agent as the name appears on the document or on the computer screen. The

Appendix D

payee's signature must be written in black or blue-black permanent ink in the proper place. Pay vouchers must be signed on the front. Signatures are required on original pay vouchers only. Treasury checks must be endorsed on the reverse (back) side within the one-inch area at the end identified for that purpose.

D-34. If the payee is unable to write, he may indicate receipt of payment by signing with the mark "X." In such instances, a disinterested party must witness the signing, and the witness' unit address and signature must be recorded. A witness may be a commissioned officer of the payee's organization or some other person specifically authorized in writing by the organization commander to perform this function. Positive identification of the witness is always required.

EMERGENCY PROCEDURES

D-35. If the paying agent becomes incapacitated for any reason (for example, by illness or accident), the advance must continue to be secured. When the incapacitation occurs, the advance must be immediately secured by the paying agent's commander or authorized representative and placed in a proper safe.

D-36. At least two disinterested officers must verify all currency, coin, and documents, and provide a written certification to the paying agent's commander for signature. One of these officers returns all funds, checks, and vouchers—along with the commander's certification—to the FM unit. The financial management personnel balance and verify the return, with the two disinterested officers acting as witnesses.

D-37. If the currency and documents are correct, the FM commander completes the DD Form 1081, thereby relieving the paying agent of responsibility. A copy of the completed DD Form 1081 is delivered to the paying agent. If the currency or payroll needs to be advanced again, the FM commander makes appropriate arrangements. If the currency and documents are incorrect, initiate an investigation or inquiry.

ENTRUSTING AND DISPOSING OF CURRENCY

D-38. The paying agent returns all entrusted currency before going on temporary duty, leave, or other assigned missions. If the paying agent must depart before returning all currency and vouchers, he notifies the FM commander before leaving. The FM commander may direct the agent to turn in the currency to the nearest military FM unit, at which time the FM commander involved clears the agent's account.

D-39. If hostile action occurs while the paying agent possesses currency, he makes every effort to return the advance to the original FM unit. If doing so is not possible, the paying agent takes one of the following actions, depending on the tactical situation:

- Returns the currency to the nearest FM unit and obtains a receipt.
- Evacuates the currency to a secure area determined by the agent's commander.
- Maintains possession of the currency until the tactical situation stabilizes to the extent that one of the above alternatives is feasible.
- Destroys the currencies. *Procedures for destroying currency are included in Appendix J.*

D-40. After the situation stabilizes, the agent informs the FM unit of the disposition of the currency and requests further instructions.

PAYING AGENT ACCOUNTABILITY

D-41. If a discrepancy is discovered and the paying agent cannot correct it, the paying agent suspends further payment and immediately notifies the FM commander. The FM commander takes appropriate action in accordance with DOD 7000.14-R, Volume 5, Chapter 6. If the paying agent fails to account for funds properly, he may be held liable for the funds, subject to an investigation.

BALANCING OF PAID AND UNPAID AMOUNTS

D-42. The paying agent balances his account and places entrusted currency and pay documents in proper order before returning to the FM unit. The paying agent will separate and total by group U.S. currency, checks for cash, paid vouchers, negotiated checks, and foreign currency. The total of U.S. currency plus

paid (signed) checks, paid (signed) vouchers, and foreign currency (U.S. cash equivalent) must equal the amount advanced on DD Form 1081. The agent assembles all cash by denomination and in bundles of 100 to help clear the account efficiently.

RETURNING CURRENCY

D-43. Currency is returned at a time specified by the FM commander. If the agent is unable to return the currency as scheduled, he notifies the FM commander immediately.

CLEARING ACCOUNTS

D-44. To clear the account, the FM commander's representative does the following:

- Receives the return.
- Verifies the correctness of endorsements on paid documents.
- Groups and totals all pay documents.
- Determines the amount of the cash turn-in.
- Prepares and verifies the correct balance on DD Form 1081 for return.
- Verifies the cash turn-in with DD Form 1081.
- Has the paying agent sign DD Form 1081, returning the paying agent's account to zero.
- Obtains the signature of the disbursing officer to complete the turn-in and relieves the paying agent of responsibility.
- Notifies the FM commander of any discrepancy.

This page intentionally left blank.

Appendix E

Fiscal Appropriations, Authorities, and Agreements

This Appendix describes DOD and non-DOD authorities and procedures and, when possible, gives examples of how these authorities and sources of funds have been utilized to support a variety of joint operations. Some of the more important agreements—useful to a complete understanding of FM in joint and multinational operations—are also discussed. This Appendix provides only an overview; in most cases, financial managers, along with their appropriate legal advisors, should consult the proper law, regulation, or directive prior to any expenditure of resources.

DEPARTMENT OF THE ARMY AUTHORITIES

OPERATIONS AND MAINTENANCE APPROPRIATIONS

E-1. **Purpose.** Operations and maintenance (O&M) appropriations pay for the day-to-day expenses of DOD components in garrison, and during exercises, deployments, and military operations. However, there are threshold dollar limitations for certain types of expenditures, such as purchases of major end items of equipment and construction of permanent facilities. Once expended, O&M accounts may be replenished for specific operations through supplemental appropriations from Congress, reprogramming actions, or the UN.

E-2. **Procedures.** The CJCS provides an execute order to a combatant commander describing mission requirements. Normally, the combatant commanders' Service components fund their participation in the operation with O&M funds.

E-3. **Examples.** The O&M funds were used to deploy U.S. forces on operations in Haiti, Bosnia, Rwanda, and Somalia. The O&M funds were also used to construct migrant camps in Guantanamo Bay, Cuba, and to transport migrants, based on a Presidential Determination. The O&M appropriation was also spent during the initial stages of Operation UPHOLD DEMOCRACY to restore power and repair bridges in Haiti. These expenditures were approved because the U.S. commander was authorized to expend DOD funds for activities essential to performance of the mission. The on-scene commander determined these civic improvements were necessary to enhance the security of U.S. forces.

MILITARY CONSTRUCTION APPROPRIATIONS

E-4. **Purpose.** Congressional oversight of military construction (MILCON) is extensive. Specific approval is required for any project above an established dollar threshold. Funds for these large construction projects require specific Congressional approval and are provided in the annual Specified Military Construction Program. MILCON appropriations also fund part of the Unspecified Minor Military Construction Program. The Secretary concerned, under the authority of 10 USC 2805a, may use minor MILCON funds for minor projects not specifically approved by Congress. Statutory authority contained in 10 USC 2803 and 2804 addresses this issue. This authority is limited to projects within prescribed dollar threshold limits. The O&M funds may be used for unspecified minor construction under \$750K. Maintenance and repair are not considered construction, and expenditure of O&M for these purposes is not subject to the construction expenditure limitation. Maintenance and Repair, up to \$3M, is authorized for OMA. Up to \$1.5M of OMA is authorized in circumstances required to preserve health, welfare, and safety/force protection of forces. Maintenance is recurrent work to prevent deterioration and to maintain the facility in usable condition. Repair is the restoration of a facility in order that it may be used for its original purpose. When construction and maintenance or repair are performed together as an integrated

Appendix E

project, each type of work is funded separately, unless the work is so integrated that separation of construction from maintenance or repair is not possible. In such cases, all work is funded as construction.

Note: The Secretary of Defense is authorized to undertake emergency construction projects not otherwise authorized by law that are necessary to support the Armed Forces. Such projects are funded with any unobligated MILCON and family housing appropriations. See 10 USC 2808.

TRADITIONAL THEATER COMMANDER ACTIVITY FUNDING

E-5. **Purpose.** Traditional theater commander activity (TCA) funds are used by the combatant commander to promote regional security and other U.S. national security goals. These funds fulfill the combatant commanders' need for flexible resources to interact with the militaries in their AO to promote regional security and other national security goals. TCA funds are not intended to replace or duplicate any other specifically authorized appropriated fund sources available to the combatant commanders. Services provide this funding with both O&M and military personnel appropriations.

E-6. **Procedures.** Combatant commanders are responsible for direct oversight and execution of traditional unified commander activities within established policy and legal guidelines. The DOD and members of appropriate interagency working groups exercise broad review and policy oversight.

E-7. **Examples.** Some examples of the use of TCA funding include military liaison teams, traveling contact teams, state partnership programs, regional conferences and seminars, unit exchanges, staff assistance and assessment visits, joint and combined exercise observers, and bilateral staff talks.

THEATER COMMANDER INITIATIVE FUND, 10 USC 166A

E-8. **Purpose.** Commander initiative funds (CIFs) (10 USC 166A) provide combatant commanders with funds to support new, unprogrammed, emergent requirements occurring during the fiscal year. Funds may be used for command and control, joint exercises, humanitarian and civic assistance, military education and training to military and related civilian personnel of foreign countries, personnel expenses of defense personnel participating in bilateral or regional cooperation programs, and force protection.

E-9. **Procedures.** The combatant commander requests the CJCS to provide funds for a specific purpose.

E-10. **Examples.** This authority was used to provide initial JTF communication support in Rwanda. It was also used to provide some of the initial support required to establish the migrant camp operations at Guantanamo Bay, Cuba.

OFFICIAL REPRESENTATION FUNDS (.0012)

E-11. **Purpose.** Occasionally, there is a requirement to support foreign military forces at official functions.

E-12. **Procedures.** Reference Service regulations and/or directives regarding proper obligation and expenditure of these funds.

E-13. **Examples.** Examples of when these funds may be proper to use include Fourth of July celebrations, changes of command, special meals, or gifts to foreign contingent commanders. *See AR 37-47, Representation Funds of the Secretary of the Army, for additional information.*

HUMANITARIAN ASSISTANCE, 10 USC 2551

E-14. **Purpose.** 10 USC 2551 authorizes appropriated funds to transport U.S. Government-procured humanitarian relief supplies and for other authorized humanitarian purposes.

E-15. **Procedures.** To the extent funds are authorized and appropriated for humanitarian assistance purposes, DOD funds can be used for military or commercial transportation. Currently, the DSCA manages these funds, which are contained in the overseas humanitarian, disaster, and civil aid account. The

supported combatant commander will forward requests to the Joint Staff for review and approval by DSCA and the Assistant Secretary of Defense (Special Operations and Low Intensity Conflict)(ASD(SO/LIC)).

E-16. **Examples.** Humanitarian assistance funds were provided to the U.S. European Command for combined joint task force PROVIDE COMFORT in 1993-1994 to transport food, staples, and shelter materials to the refugees in Northern Iraq.

TRANSPORTATION OF HUMANITARIAN ASSISTANCE, 10 USC 402

E-17. **Purpose.** 10 USC 402 provides for the military transportation of donated humanitarian relief supplies, subject to certain conditions. Assistance under this section is commonly referred to as the Denton Program and is jointly administered by USAID, the DOS, and the DOD.

E-18. **Procedures.** The DOD is authorized to transport donated supplies from NGOs intended for humanitarian assistance purposes. This transportation is authorized without charge but on a space-available basis. Before supplies can be transported, the DOD must determine that the transportation of the supplies is consistent with U.S. foreign policy, that the supplies to be transported are suitable for humanitarian purposes and in usable condition, that a legitimate humanitarian need exists for the supplies by the people for whom the supplies are intended, that the supplies will be used for humanitarian purposes, and that adequate arrangements have been made for the distribution of the supplies in the destination country by the NGO. DSCA manages the program and the funds. The supported combatant commander will forward requests to the Joint Staff for approval by DSCA.

E-19. **Example.** This authority was invoked to transport food and clothing to Rwanda for NGOs such as World Relief in 1994.

HUMANITARIAN AND CIVIC ASSISTANCE PROVIDED IN CONJUNCTION WITH MILITARY OPERATIONS, 10 USC 401

E-20. **Purpose.** 10 USC 401 allows the Service components to carry out humanitarian and civic assistance activities abroad. Projects must promote U.S. and HN security interests, as well as enhance readiness skills of the U.S. forces participating. These projects are to be conducted in conjunction with authorized military operations and can complement, but not duplicate, other assistance provided by the U.S. Government. Humanitarian and civic assistance (HCA) is confined to five general areas, which are defined by statute: medical, dental, and veterinary care; construction of rudimentary surface transportation; well drilling and construction of basic sanitation facilities; rudimentary construction of public facilities; and detection and clearance of landmines, including education, training, and technical assistance. The HCA projects cannot benefit any individual or organization engaged in military or paramilitary activity.

E-21. **Procedures.** The HCA projects must be nominated by the HN government and must be supported by the U.S. Embassy, the DOS, USAID, and the DOD. Section 401 activities are funded from the Services' O&M accounts. The ASD(SO/LIC) provides oversight within the DOD.

E-22. **Examples.** The HCA projects have included such activities as rudimentary construction and repair of public facilities, drilling wells for water, and providing medical, dental, and veterinary care in rural areas to such countries as Ethiopia, Panama, Haiti, and Bangladesh.

EMERGENCY AND EXTRAORDINARY EXPENSE AUTHORITY, 10 USC 127

E-23. **Purpose.** Emergency and extraordinary expense (E&E) authority (10 USC 127) provides the Secretary of Defense and Service secretaries authority to expend O&M funds without regard to contracting and purpose limitations. This authority is provided annually in the O&M appropriations. Each Secretary has different amounts, depending on previously established needs. The E&E funds are funds used to support certain unique requirements of operations. The DOD and Service regulations covering these funds define the types of acceptable expenditures.

E-24. **Procedures.** Very small amounts of this authority exist. The combatant commander can request the Service component to provide this E&E. If E&E is available and no other funds are appropriate to resource

Appendix E

an essential activity, the combatant commander's Service component normally requests approval of the Service secretary through the Service headquarters. This authority does not provide cash or foreign currency to conduct an activity. Rather, E&E provides the capability to obligate Service funds for an activity normally not authorized for O&M funding. If foreign currency is required to perform the activity, a Service finance office must be notified to obtain the appropriate currency.

E-25. **Examples.** This authority was used to "buy-back" weapons in Panama during Operation JUST CAUSE. It was also cited initially for purchasing weapons in Haiti during Operation UPHOLD DEMOCRACY. Standing authorizations include special operations, criminal investigation purposes, and intelligence contingencies. These requests must have approval on a case-by-case basis.

FOREIGN DISASTER ASSISTANCE, 10 USC 404

E-26. **Purpose.** 10 USC 404 provides the President with the authority to direct the DOD to conduct foreign disaster assistance when necessary to prevent loss of life. This section enables the DOD to use its unique airlift and rapid deployment capabilities to address humanitarian problems caused by natural or manmade disasters worldwide. Assistance provided under this section may include transportation, supplies, services, and equipment.

E-27. **Procedures.** This legal authority provides for the military transportation of donated humanitarian relief subject to certain conditions. Assistance under this section is commonly referred to as the Denton Program and is jointly administered by USAID, the DOS, and the DOD. Fiscal year 1995 was the first year the DOD had specific authority to conduct worldwide disaster relief activities.

E-28. **Example.** This authority was cited to provide blankets, water, and transportation to the earthquake-stricken people in Japan.

EXCESS NONLETHAL DEFENSE SUPPLIES, 10 USC 2557

E-29. **Purpose.** 10 USC 2557 makes nonlethal excess DOD supplies available for humanitarian relief purposes.

E-30. **Procedures.** The DOD transfers nonlethal excess supplies to the DOS for distribution.

E-31. **Example.** This authority could be cited to transfer medical supplies, meals ready to eat, and equipment in support of a humanitarian relief effort.

OTHER AUTHORITIES

DRAWDOWN AUTHORITIES

E-32. There are three drawdown authorities contained within the FAA of 1961. All three require a Presidential Determination and some form of notification to Congress. They are available for use within each fiscal year up to a specified dollar amount. The calculation of costs for all goods and services provided under these authorities, and reported to Congress, is on the basis of "full cost to the Government." The calculation of costs includes the full cost of all military and civilian labor associated with the drawdown. Although these authorities are limited to existing defense stocks, a reduction of items from inventory below the reorder point may cause a new procurement action to replenish stocks. Such authority generally does not have funding attached. Drawdown authority does not draw a distinction between stocks that are at the retail or wholesale level.

E-33. This authority provides defense articles, equipment, military education, and training. It can also provide DOD services. Examples include military transportation, military sealift, and military personnel offloading ships. This authority cannot be used for new contracting or procurement. It can be cited by the DOD to contract for commercial airlift, or sealift, if more economical. However, it cannot be used to provide housing and food under a logistics civil augmentation program contract to members of a foreign country or international organization.

E-34. When drawdown authority is granted, specific statutes require the President to report to Congress the extent to which stocks and services are drawn down. The DOD agency responsible for reporting this information is the DSCA. As such, DSCA is the DOD central point of contact for accounting how much drawdown authority has been used and establishes the reporting requirements for this type of support.

E-35. Under normal circumstances, the DSCA may use this authority to direct the provision of supplies in two ways. First, DSCA may assemble a rush package to be sent to the appropriate foreign contingent. Second, DSCA may use an execute order to direct certain stocks be provided to a specific foreign contingent.

Drawdown for an Unforeseen Emergency, FAA Section 506(a)(1), 22 USC 2318 (a)(1)

E-36. **Purpose.** Under section 506(a)(1) of the FAA, military assistance (defense articles and services) can be furnished to a foreign country or international organization on a nonreimbursable basis due to an unforeseen emergency. This action requires a Presidential Determination and report in advance to Congress that an unforeseen emergency exists that cannot be met under the Arms Export Control Act (AECA) or any other law. Peacekeeping is a recognized purpose for use of this drawdown authority.

E-37. **Procedures.** Normally, requests are initiated by the U.S. Embassy in the concerned country and forwarded to the DOD. The combatant commander may also identify needs to the Plans Directorate (J5) for forwarding to DOS or the National Security Council. Once the concept is approved, the DOS initiates documentation for the President to approve and to notify Congress. Once drawdown authority has been approved, DSCA manages the program for the DOD and provides detailed accounting procedures.

E-38. **Examples.** This authority was invoked during Operation ENDURING FREEDOM to provide vehicles and personal equipment to many of the countries providing Soldiers for the coalition force in Afghanistan. It was also invoked during operation UPHOLD DEMOCRACY in Haiti and during operations in Bosnia.

Drawdown for Refugee Assistance, FAA Section 506(a)(2), 22 USC 2318 (a)(2)

E-39. **Purpose.** The President can drawdown DOD stocks for counterdrug, disaster relief, and refugee and migrant assistance purposes. This authority provides articles, equipment, and training. It can also provide DOD services. Examples include military transportation, military sealift, and military personnel offloading ships. This authority can be used for new contracting or procurement or it can be cited by the DOD to contract for commercial airlift, or sealift, if more economical. However, it cannot be used to provide housing and food by contract. Under this provision, the President may authorize the drawdown of articles and services for disaster relief and counterdrug purposes and for refugee and migrant assistance under the Migration and Refugee Assistance Act of 1962. It requires a Presidential Determination and report, in advance, to Congress that it is in the national interest to execute the drawdown.

E-40. **Procedures.** As with the drawdown for an unforeseen emergency, requests are normally initiated by the U.S. Embassy in the concerned country and forwarded to the DOD. The combatant commander may also identify needs to the Plans Directorate (J5) for forwarding to DOS or the National Security Council. Once the concept is approved, the DOS initiates documentation for the President to approve and to notify Congress. Once drawdown authority has been approved, DSCA manages the program for the DOD and provides detailed accounting procedures.

E-41. **Examples.** The President invoked this authority to provide airlift for nongovernmental humanitarian relief agencies for Rwanda. It was also used to pay for military airlift and sealift of DOD water purification equipment, generators, and other related equipment. This authority was used extensively (\$75 million) for Hurricane Mitch disaster relief efforts in Central America.

Drawdown for Peacekeeping, FAA Section 552(c), 22 USC 2348a

E-42. **Purpose.** The President can drawdown commodities and services from any U.S. agency for unforeseen emergencies to support peacekeeping activities. This authority can be used for new contracting or procurement or it can be cited by the DOD to contract for commercial airlift, or sealift, if more

Appendix E

economical. However, it cannot be used to provide housing and food. It requires a Presidential Determination and report, in advance, to Congress that an unforeseen emergency exists requiring the immediate provision of assistance.

E-43. **Procedures.** As with the drawdown for an unforeseen emergency, requests are normally initiated by the U.S. Embassy in the concerned country and forwarded to the DOD. The combatant commander may also identify needs to the Plans Directorate (J5) for forwarding to DOS or the National Security Council. Once the concept is approved, the DOS initiates documentation for the President to approve and to notify Congress. Once drawdown authority has been approved, DSCA manages the program for the DOD and provides detailed accounting procedures.

E-44. **Examples.** This authority was invoked to provide vehicles to the Palestinians in support of peace operations with Israel and was considered for helicopter support to the multinational observers in the Peru–Ecuador border dispute. This authority was also used to provide \$25 million to support the reconstitution of the Somalia police force.

FOREIGN MILITARY SALES, 22 USC 2761

E-45. **Purpose.** Foreign military sales (FMS), 22 USC 2761, is used to sell defense articles and services to the UN and foreign governments. Foreign governments and the UN may enter into a standard foreign military sales arms contract with the DOD for the sale of defense articles and services. This is the primary authority to lease defense articles to third world countries and international organizations. Foreign Military Sales is generally regarded as the least preferable authority because of inflexible contract terms, higher costs, and lengthy processing time.

E-46. **Procedures.** The UN or another country can enter into a FMS contract with the DOD through a letter of assist (LOA). Ordinarily, the country pays the DOD in advance for all costs plus an administrative surcharge. Foreign Military Sales and ACSAs are the only authorities available to the DOD to lease defense articles. Leases are processed as standard FMS cases and are generally on a reimbursable basis. However, leases of defense articles may be made on a nonreimbursable basis if the article has passed three-quarters of its normal service life.

E-47. **Examples.** This authority was used to lease armored personnel carriers (APCs), tanks, and helicopters to the UN for use in Somalia and to lease APCs to the UN for use by the Ghanian battalion in UN Assistance Mission in Rwanda (UNAMIR). Sales of related equipment, repair parts, and airlift services were done under the FAA Section 607.

EXCESS DEFENSE ARTICLES, 22 USC 2321J

E-48. **Purpose.** The excess defense articles (EDA) provision (22 USC 2321J) gives the authority to sell or grant articles no longer needed by the Armed Forces of the United States to eligible countries. It authorizes lethal and nonlethal support on a priority basis to countries on the southern and southeastern flank of NATO. Defense articles no longer needed by the Armed Forces of the United States may be made available for sale under FMS procedures or on a grant (no cost) basis to eligible countries. The purpose is to modernize defense capabilities of eligible NATO countries on the southern and southeastern flank of NATO and to major non-NATO allies on these flanks. Eligible countries include Greece, Portugal, Turkey, Israel, Egypt, Morocco, Pakistan, Senegal, and Oman.

ECONOMIC SUPPORT FUND, FAA SECTION 531, 22 USC 2346

E-49. **Purpose.** The purpose of the Economic Support Fund (ESF) (22 USC 2346) is to furnish assistance to countries based on special economic, political, or security interests of the United States. Most ESF assistance is provided as cash grant transfers to help other countries improve their balance of payments. The remainder is spent on commodity support to import U.S. goods for development projects. The ESF shall be available for economic programs only and may not be used for military or paramilitary purposes.

E-50. **Procedures.** The President is authorized to furnish assistance to countries and organizations, on such terms and conditions as may be determined, in order to promote economic or political stability. The DOS

usually provides funds directly to the countries involved. However, DOS can provide these funds to the DOD through an agreement pursuant to the FAA, Section 632. The USD(C) and their counterparts at the DOS develop the agreement. If the combatant commander determines a need for these funds, the Joint Staff J5 may be contacted.

E-51. **Examples.** This authority was used for Somalia police salaries. In Haiti, it was used to distribute miscellaneous payments to members of the multinational force and for special transportation requirements.

PEACEKEEPING OPERATIONS FUND, FAA SECTION 551, 22 USC 2348

E-52. **Purpose.** The Peacekeeping Operations (PKO) Fund (22 USC 2348) is used to furnish assistance to friendly countries and international organizations pursuant to the national interests of the United States. The President is authorized to furnish assistance to countries and organizations, on such terms and conditions as may be determined, for PKO and programs. Such assistance may include reimbursement to the DOD for expenses incurred pursuant to Section 7 of the United Nations Participation Act (See paragraph 3h).

E-53. **Procedures.** The DOS usually provides funds directly to the countries involved. However, the DOS can provide these funds to the DOD through an agreement pursuant to FAA Section 632. The USD(C) and their counterparts at the DOS develop the agreement. If the supported combatant commander determines a need for these funds, the Joint Staff J5 may be contacted. Preferably, the Service funding the operation for the combatant commander contacts USD(C).

E-54. **Examples.** This authority was used by the DOS to pay lodging and meals for non-U.S. members of the Military Observer Group on the border between Haiti and the Dominican Republic. It was also used to pay for equipment and supplies in Haiti that couldn't be drawn down from existing DOD stocks. (see FAA S506[a][1])

INTERNATIONAL MILITARY EDUCATION AND TRAINING, FAA SECTION 541-545, 22 USC 2347 TO 2347E

E-55. **Purpose.** The international military education and training (IMET) provision (22 USC 2347 to 2347E) provides military education and training to military and related civilian personnel of foreign countries.

E-56. **Procedures.** DOS obtains a request for training from the HN government and passes the request to the DOD. If the combatant commander desires to provide military education or training to countries in the area of responsibility, it is usually arranged through the country team at the U.S. Embassy. Combatant commanders may also submit the proposal to the Joint Staff J5 for review. Once approved by the DOS, the DOD through DSCA attempts to provide the service directly. If the DOD is unable to provide the services directly, a security assistance tasking can be prepared, citing IMET funds. DSCA then contracts for the required support.

E-57. **Example.** Many foreign defense and non-defense establishments have been trained through IMET. Through their attendance at IMET sponsored training, these personnel receive exposure to U.S. values, regard for human rights, democratic institutions, and the value of a professional military under civilian control.

REIMBURSABLE AUTHORITY, FAA SECTION 607, 22 USC 2357

E-58. **Purpose.** The Reimbursable Authority, (22 USC 2357), authorizes any federal agency to furnish commodities and services to friendly countries, the American Red Cross, voluntary non-profit relief agencies, and international organizations, when the President determines such assistance furthers the purposes of Part 1 of the FAA. Support may be provided only on a reimbursable or advance-of-funds basis.

E-59. **Procedures.** The DOS obtains requests for commodities and services from the UN as well as other nations. After review, these requests may be forwarded through DOD Assistant Secretary of Defense (Strategy and Requirements) to the DSCA for execution. Once DSCA approves shipment of the

Appendix E

commodities, DFAS submits a billing statement to the UN or other organization, which then reimburses the Service. The determination required by the statute must be made each time a new operation is to be supported under this authority. The authority for making this determination has been delegated to the Secretary of State and to the Administrator of USAID.

E-60. Support of each new operation requires the negotiation and conclusion of a separate FAA Section 607 agreement. Section 607 agreements set the overall terms and conditions that govern the provision of assistance and have been used in UN operations in Somalia, the Former Republic of Yugoslavia, Rwanda, and Haiti. The UN LOA procedure is the ordering mechanism specified in those agreements.

E-61. **Reimbursements.** Under FAA Section 607, assistance may be furnished only on an advance-of-funds or reimbursable basis. Reimbursement cannot be waived. Reimbursements received may be deposited by the Service providing the assistance back into the appropriation originally used—or, if received within 180 days of the close of the fiscal year in which the assistance was furnished, into the current account concerned. These amounts then remain available for the purposes for which they were appropriated. Reimbursements received after this 180 day period cannot be retained by the DOD and must be deposited in the miscellaneous receipts account of the general treasury.

E-62. **Examples.** This authority was used by the DOD to support UN operations, the Organization of African Unity, and friendly third world countries participating in peacekeeping and humanitarian operations in Rwanda. It was also cited for Operation SAFE BORDER when Peru and Ecuador agreed to reimburse the United States for its costs of providing the observer group to monitor their common border.

SECTION 7 OF THE UNITED NATIONS PARTICIPATION ACT, 22 USC 287D-1

E-63. **Purpose.** Section 7 of the United Nations Participation Act (UNPA) (22 USC 287D-1) authorizes support to UN PKO. This authority permits the DOD to contribute personnel, nonlethal equipment, supplies, and services to UN operations.

E-64. **Procedures.** The UN issues a letter of agreement (LOA) to the U.S. Mission to the UN in New York (USUN). The USUN forwards the LOA to the DOD, where it is reviewed and transmitted to the DOD with a recommendation as to approval and funding. Within the DOD, the Under Secretary of Defense for Policy (USDP) coordinates the UN request. Upon approval, the DOD directs a Service to implement the LOA.

E-65. **Reimbursements.** Reimbursement is ordinarily required from the UN. However, reimbursement may be waived when the President finds exceptional circumstances or that such waiver is in the national interest. The DOS also has the authority to waive reimbursement after consultation with the DOD.

E-66. **Examples.** Examples include DOD support to UN operations in Cambodia, Angola, and Western Sahara.

FAA SECTIONS 628 AND 630, 22 USC 2388 AND 2390

E-67. **Purpose.** Upon determination by the President, Section 628, 22 USC 2388 and 2390 authorizes the head of an agency to detail or assign any officer or employee of their agency to an international organization, to serve on an international staff or “to render any technical, scientific, or professional advice or service” to such organization. This is all possible if it meets the purposes outlined by the FAA. There is no limit on the number of personnel that may be detailed under this authority. This authority has been interpreted broadly and has been used as authority to detail U.S. military to peace enforcement operations.

E-68. **Reimbursements.** Reimbursements for Section 628 details are governed by Section 630 of the FAA. U.S. policy is that the DOD will be reimbursed the incremental costs associated with the participation of the U.S. military in a UN operation.

E-69. **Example.** This authority was used to provide U.S. logisticians to Somalia as part of peace enforcement operations.

THE ECONOMY ACT, 31 USC 1535, ET SEQ.

E-70. **Purpose.** The Economy Act (31 USC 1535) provides general authority for federal interagency transactions. It authorizes interagency transactions when no other statute permits the providing agency to render the requested service.

E-71. **Procedures.** The act requires full reimbursement to the providing agency, including indirect costs. It authorizes the provision of defense articles and services indirectly to third world countries, the UN, and international relief organizations on a reimbursable basis. Under this approach, the DOS or other Federal agencies submit a funded interagency request for support to the DOD.

E-72. **Example.** Until recently, this has been the primary authority to provide disaster assistance to third world countries.

STAFFORD DISASTER RELIEF AND EMERGENCY ASSISTANCE ACT, 42 USC 5121, ET SEQ.

E-73. **Purpose.** The Stafford Disaster Relief and Emergency Assistance Act (42 USC 5121) provides for an orderly and continuing means of assistance by the Federal government to state and local governments in carrying out their responsibilities to alleviate disaster related suffering and damage.

E-74. **Procedures.** Upon the request of the affected state's governor, the President may declare an emergency or major disaster, thereby permitting mobilization of Federal assistance under the Act. The Stafford Act requires reimbursement to the DOD for the incremental costs of providing support. Approval authority and reporting requirements vary depending on the duration and type of support requested. The President may direct any agency of the Federal government to undertake missions and tasks on either a reimbursable or nonreimbursable basis.

AGREEMENTS**UNITED NATIONS LETTER OF ASSIST**

E-75. A UN letter of assist (LOA) is a document issued by the UN to a contributing government authorizing that government to provide goods or services to UN peacekeeping forces. An LOA typically details specifically what is to be provided by the contributing government and establishes a not to be exceeded funding limit. General support LOAs can be negotiated with the UN (if such LOAs are advantageous to both parties) to cover more generic categories, such as subsistence, fuel, sustainment, and spare parts. More than one item or service can be included on an LOA. LOAs are considered by the UN to be contracting documents and must be signed and issued by the UN Director, Field Operations Division. The LOA is not considered a funded order, and the UN does not normally provide an advance of funds for the value of the LOA.

E-76. The UN reimburses contributing countries for the costs of their activities in accordance with UN standard procedures, and specific or general LOAs. The UN should approve all elements of national contributions and the extent of reimbursement prior to an actual deployment, if possible. Therefore, activities undertaken, troops deployed, or costs incurred for items and services rendered that are not agreed to in advance by the UN are not normally reimbursed by the UN. Only expenditures in support of an operation approved by the Security Council and authorized by the General Assembly as a legitimate charge to the UN are eligible for reimbursement.

ACQUISITION AND CROSS-SERVICING AGREEMENT, 10 USC 2342

E-77. **Purpose.** The purpose of the acquisition and cross-servicing agreement (ACSA) authority provided under 10 USC 2342 is to acquire or transfer logistic support outside the Arms Export Control Act (AECA) channels. This is a limited, DOD-specific authority both to acquire logistic support without resort to commercial contracting procedures and to transfer logistic support outside of AECA channels. Under this authority, the DOD, after consultation with DOS, may enter into agreements with NATO countries, NATO subsidiary bodies, other designated eligible countries, the UN, and other international regional organizations, of which the United States is a member, that provide for the reciprocal provision of

Appendix E

sustainment support, supplies, and services. This authority is limited to the purchase and sale of sustainment support and does not extend to major end items of equipment such as trucks or weapons systems. As a result of the FY 1995 National Defense Authorization Act changes, the DOD is authorized general-purpose vehicles and other nonlethal items of military equipment that are not designated as significantly military equipment on the U.S. munitions list. Examples include vehicles, communications equipment, and training aids.

E-78. **Procedures.** After consulting with DOS, the DOD may enter into agreements with NATO countries, NATO subsidiary bodies, and other designated eligible countries for reciprocal sustainment support, supplies, and services. However, major end items are excluded. Acquisitions and transfers are on a payment in cash (PIC), replacement-in-kind (RIK), or equal value exchange (EVE) basis. The RIK or EVE must be accomplished within 12 months after the date of delivery of the sustainment support, supplies, or services. After 12 months, reimbursement must be on a cash basis.

E-79. **Examples.** This authority was used extensively during Operation ENDURING and IRAQI FREEDOM. This authority has also been used in peace operations conducted by member state coalitions under UN auspices (for example, the Unified Task Force phase of the Somalia operations with Canadian and Australian forces), as well as in Bosnia and Kosovo.

MEMORANDA OF AGREEMENT

E-80. Memoranda of agreement (MOAs) are agreements between countries or eligible organizations delineating responsibilities among the participants. Among these responsibilities are the participants' financial liabilities for support. These agreements define the specific mechanisms required for reimbursement of costs. An example of the use of this authority is when coalition partners cooperate in a military operation. In this case, support can be provided to foreign forces with which the United States has an MOA. The MOAs between the DOD and the defense ministries of other nations or between the DOD and international organizations must be based on specific legal authority and negotiated in accordance with proper procedures.

632 AGREEMENTS (DEPARTMENT OF STATE FUNDS)

E-81. The Department of State (DOS) and the DOD may negotiate agreements in which the DOD agrees to fund requirements initially that are legally a DOS responsibility. These agreements are called 632 Agreements. They are generally negotiated for a specific purpose with a specific amount of funds attached. Once these agreements are signed, they provide the legal authority for the DOD to incur obligations on a reimbursable basis for the purpose intended. The documentation is consolidated and sent to the DOS for reimbursement.

E-82. Examples of the use of this agreement by the DOD and the reimbursement by the DOS include the paying of stipend payments to foreign military forces, providing support to foreign military forces not covered under 506 (a)(1) drawdown authority, funds to cover emergency medical evacuation of foreign Soldiers to U.S. medical facilities, and providing special dietary requirements for foreign contingents.

Appendix F

Financial Management Support to Military Operations in a Multinational Environment

Multinational operations is a collective term describing military actions conducted by forces of two or more nations, typically organized within the structure of a coalition or alliance. An alliance is a result of formal agreements (treaties) between two or more nations to meet broad, long-term objectives (for example, NATO). A coalition is an ad hoc arrangement between two or more nations for common action (for example, Operation Iraqi Freedom). Financial considerations for ad hoc arrangements are similar to those for UN operations.

Non-traditional military operations, such as PKO and humanitarian assistance, have evolved alongside the traditional forms of military action (deterrence and warfighting). In the future, international organizations and agencies will perform an increasing role in the management of these crises and contingency operations. The level of U.S. participation in these operations depends on the objectives agreed to at the national level. Nations must also reach agreement—separately or through cooperative agreements—to provide FM resources or specific support requirements for their forces. Financial managers must ensure available support assets meet not only U.S. standards, but also those of supported multinational forces. FM support, however, remains a national responsibility for multinational operations.

UN OPERATIONS

F-1. A variety of missions may be conducted in conjunction with the UN. Section 7 of the UNPA authorizes support to UN PKO. This authority allows the DOD to contribute personnel, nonlethal equipment, supplies, and services to UN operations. Support provided to the UN under Section 7 of the UNPA does not require the negotiation of an agreement. However, formal agreements, such as FAA section 607 and section 628 agreements, and UN LOAs, are established in most cases to facilitate reimbursement for services provided.

F-2. Any support provided to UN forces must be preapproved by a UN official authorized to commit funds. This official is normally the chief administrative officer or the chief procurement officer. Activities undertaken, troops deployed, or costs incurred for items that are not agreed to in advance by the UN, as identified and detailed in guidelines, aides memoire, notes verbale, or specific or general LOAs, are normally not reimbursed by the UN. Financial responsibilities of each party are usually spelled out in the agreement between the contributing countries and the UN. The U.S. position is normally negotiated by the DOD in coordination with the DOS. Close coordination with UN officials throughout the operation should ensure proper reimbursement for all authorized expenditures.

F-3. When participating with the UN, two types of documents are critical to FM. The first is standing agreements that are in place related to contributing country participation in a UN operation. The second is LOAs.

Appendix F

F-4. **Standing agreements.** The standing agreements are general in nature and provide guidelines on what the UN is willing to pay for without any additional, specifically negotiated, agreements. An understanding of these documents early in an operation is essential to ensure proper reimbursement for U.S. participation in a UN operation. The following are some examples of the types of support arrangements listed in the standing UN procedures:

- **Pre-deployment actions.** Preparation of personnel and equipment for deployment is the responsibility of the contributing country and includes all preparation costs involved to get the personnel or equipment to the point of embarkation. Billing the UN for reimbursement of these expenses is based on advance negotiations with the UN.
- **Deployment and redeployment—**
 - **Actions.** Transportation to and from the AO is normally by air or sealift. The UN can fund all deployments and redeployments. The contributing government may organize these activities, but the UN must agree to the arrangements in advance. All transportation to be provided by the contributing country must be coordinated and approved by the UN. If reimbursement is requested, it will be made only up to the amount it would have cost the UN to accomplish the move.
 - **Self-sufficiency period.** Each contingent force must be self-sufficient in theater until UN operations and control are sufficiently established to provide sustainment. The UN will reimburse normal and agreed to costs incurred during the self-sustainment period. All deployed military units should be self-sufficient in rations, water, petroleum, oils, and lubricants (POL) for a minimum of 30 days, and other classes of supplies for a minimum of the first 60 days after deployment.

F-5. **LOAs.** The other method the UN uses to request support is LOAs. A UN LOA is a document, issued by the UN to a contributing government, authorizing that government to provide goods or services to the UN. An LOA details specifically what is to be provided by the contributing government and establishes a funding limit that cannot be exceeded. General support LOAs can be negotiated with the UN, if such LOAs are advantageous to both parties, to cover more generic categories such as subsistence, POL, sustainment, and repair parts. LOAs are considered by the UN to be contracting documents and must be signed and issued by an authorized UN official.

- The UN issues the approved LOA to the United States Mission to the United Nations (USUN), where it is acted on by the military advisor. The Office of the Military Advisor determines the appropriate U.S. agency to receive the request. All requests from the DOD are forwarded to the Under Secretary of Defense for Policy (USD(P)) for approval and action. The USD(P) will determine the appropriate organization and provide a copy of the LOA to the organization and DFAS. The DFAS is responsible for maintaining a status of all active LOAs.
- The LOA is not considered a funded order, and the UN does not ordinarily provide an advance of funds for the value of the request. Therefore, an LOA does not provide to a Service any additional obligation authority to accomplish the order. The Service must accomplish the requirement using existing O&M funds or other appropriated funds, and prepare an SF 1080 (Voucher for Transfers Between Appropriations and/or Funds) bill for the cost of the goods or services provided, referencing the appropriate LOA.

F-6. **UN personnel reporting.** The UN reimburses participating countries for personnel provided. The UN pays providing countries a basic monthly rate per person for pay and allowances, plus a usage factor for clothing and equipment. The UN reimbursement rate to providing nations in 1997 was \$988 per Soldier per month, plus a usage factor per Soldier and a supplementary payment for specialists.

NATO OPERATIONS

F-7. **Background.** The North Atlantic Treaty Organization (NATO) is a defense treaty which resulted in the alliance of 26 countries (member states). Under Article 5 of the North Atlantic Treaty, an attack upon the territorial integrity of a treaty member is considered an attack on all member states. While mutual defense remains the primary mission of the Alliance, NATO has recently expanded its sphere of activities to include peace support missions outside the territorial boundaries of the allied nations. Such non-Article 5, or “out-of-area,” operations may be undertaken at the request of the UN with the unanimous consensus of all member states.

F-8. **NATO funding eligibility.** NATO conducts missions on the basis of force and capability contributions from its member states. Unlike the UN, it does not provide reimbursement for peacekeeping forces or in any other way underwrite the costs of national participation. As a result, NATO operating budgets are small in relation to those of national forces deploying in support of an operation. NATO funding is generally restricted to establishment and support of the NATO headquarters in theater. In exceptional circumstances, the NATO nations may fund theater-wide projects benefiting both the NATO headquarters and all nations with forces in theater (for example, theater communications systems or certain engineering projects supporting main supply routes or ports). The NATO headquarters may establish a multinational logistics center to coordinate this effort among the forces in theater.

F-9. **NATO funding sources.** The support of national forces in the theater is a national responsibility and is funded through national systems and budgets. In the exceptional circumstance that a category of expenditure might be considered eligible for NATO funding, the requirement must be submitted through the NATO theater headquarters for inclusion in the budgetary plans described above. NATO funds its command and control structure through two primary sources—

- The NATO Security Investment Program is generally used to support major investments in operational infrastructure, such as construction or communications systems. Projects originate with the NATO theater headquarters engineers and are subsequently screened by the NATO chain of command prior to being reviewed by the NATO Infrastructure Committee at NATO headquarters in Brussels, Belgium. Funding is approved and provided on a project-by-project basis. Funds cannot be transferred between projects.
- The NATO military budget is the normal source of funding for O&M costs supporting NATO headquarters in the theater of operations. NATO theater headquarters funding requirements are assembled by the theater financial controller and consolidated into an operational budget. This budget is screened by the NATO chain of command prior to submission to the Military Budget Committee, also located in Brussels. Funding is approved in accordance with the proposed expenditure plan; however, there is generally some flexibility between budgetary line items.

F-10. **Centralized contracts.** To reduce competition for resources in the theater, the NATO headquarters may solicit and consolidate theater-wide requirements in order to negotiate basic ordering agreements with local vendors. Such agreements typically establish the prices, ordering procedures, and payment terms, but do not obligate NATO or the nations to purchase specific quantities of goods or services. While allied nations are generally authorized to utilize such contracts on the same basis as the NATO headquarters in-theater, the existence of such agreements does not preclude nations from negotiating their own bilateral contracts. NATO does not finance national requirements; such contracts call for nations to make direct payment to vendors for goods and services they order.

This page intentionally left blank.

Appendix G

Financial Management Support to Theater Support Contracting

Contracting can be an effective sustainment force multiplier during contingency operations. Doctrinally, there are three types of contingency contracts: system support, external support and theater support. Tactical financial managers normally provide general support (GS) to the theater support contracting officers, referred to as contingency contracting officers (CCOs), especially in operational areas where there is no functional banking systems. Additionally, tactical FM units may support field ordering officer (FOO) payments for minor goods and services as authorized by the theater Army's principle assistant responsible for contracting (PARC).

Theater support contracting and FOO support require an understanding of the legal requirements, funding issues, and the duties and responsibilities of procurement personnel, their relationship with support staff, and their requirements in deployment preparation. The ability to work with people who have vastly different cultures, backgrounds, perspectives and, most importantly, business practices, is another aspect of theater support contracting that has considerable impact on successful support of a joint operation. CCOs are responsible to ensure that all theater support contracting and FOO support are performed IAW PARC guidance and strictly follow Federal Acquisition Regulation (FAR) and Service FAR supplement guidance.

Local business practices, a less-than-stable environment, and the contractor's lack of knowledge of U.S. payment and contracting procedures may require CCOs to arrange for immediate payment. Immediate payment can be made through credit cards, cash, or check. Payment for services may be appropriate at the conclusion of each work day, work week, or upon completion of each specified period of performance. In many cases, the responsiveness of contractors is directly attributed to the timeliness of the payment. Advance payments are the least preferred method of payment, and should be used only when it is in the best interest of the government. Recouping money or forcing a contractor to perform according to contract standards through negotiation and litigation after an advance payment may not get the mission accomplished in a timely manner.

PLANNING

G-1. Advance planning and preparation is critical to the success of the theater support contracting effort. Theater support contracting and FOO actions are planned for by the PARC in coordination with the ASCC G4, the TSC, and the AFSB. The details of this planning along with specific CCO and FOO guidance can be found in the CSP which is published as a separate annex to the logistics appendix of the overall OPLAN. All team members must have a basic understanding of the contents of the CSP as well as general knowledge of applicable legal authorities, funding practices, and technical aspects of how to execute their duties in a tactical environment.

Appendix G

DEPLOYMENT

G-2. **Early Entry Team.** The early entry team should consist of a senior contingency contracting team (SCCT), unit FOOs and an FM support team. In some operations, the SCCT may deploy under the C2 of the AFSB early entry module with technical oversight being provided by the PARC. Depending on the mission, the early entry team should include a finance operations representative, a resource management operations representative, disbursing section/officer and a legal advisor.

G-3. **Typical organization structure.** Normally, a SCCT, along with a support staff of contracting and FM personnel, establish the Army force theater support contracting organization within the first 30 days to augment the initial deployment of an early entry team. Contracting personnel coordinate with the agencies assisting in the contracting function (for example, legal advisors, financial managers, and civil affairs (CA)). In some operations, the JFC may dictate that theater support contracting be controlled by either a lead Service (not necessarily the Army) or even a joint contracting command. What this means to U.S. Army tactical commanders is that in some operations, theater support contracting support may be provided by CCOs from another Service on an area support basis.

FUNDING

G-4. **Finance operations and contracting relationships.** CCOs must coordinate with FM units to ensure timely and accurate payments for supplies and services. Regardless of the method of procurement (credit card, purchase order-invoice voucher, SF 44, blanket purchasing agreement, or contract), contractors conducting operations in an austere environment may require immediate payments.

G-5. **RM operations relationships.** The financial manager verifies the availability of appropriate funds through signature certification. The financial manager and contracting officer must work closely together during any type of contingency operation to ensure funds are appropriate, valid, and sufficient.

G-6. **Funding procedures.** Accounting data is required on all contractual documents.

CONTRACTING OFFICER WARRANT LIMITATIONS

G-7. In most instances, CCO's warrants are limited in what they can procure. The CCO has the mission to provide services and supplies necessary to sustain the operation as dictated by the CSP. In most cases, the contracting officer will not have the authority to contract for the procurement or lease of real property or major construction contracts. These specific engineering contracting functions are usually delegated to a CCO warranted to support civil engineering missions required during the operation.

CONTRACT CLOSEOUT

G-8. As the contract nears completion, the contracting organization begins the contract closeout process. The regional contracting offices close out contracts and procurement actions, and shift contracts without outstanding deliveries to the contracting headquarters. A team of contracting personnel remains in the AO until contracting requirements cease and the ongoing procurement activity is terminated. The FM support must continue in order to process claims and final payments of contracts. *See FM 100-10-2, Contracting Support on the Battlefield, for additional information on theater support contracting.*

Appendix H

Obligation Management

Obligation management is a basic function of RM operations. Tracking obligations enable financial managers to—

- Calculate and report available funding.
- Determine if commitment accounting systems interface issues are occurring.
- Monitor non-stock orders and payables to—
 - Determine obligation adjustments.
 - Locate obligations in excess of disbursement, and deobligate the balance for other funding needs or those that require increase.
- Identify delays or significant time lags in transactions.
- Identify undelivered or delayed orders.
- Determine cancellations.
- Identify patterns in obligation estimates versus actual expenses.
- Identify increased or decreased obligation performance in programs, AMSCOs, or APCs.
- Calculate the liquidation performance ratio.
- Calculate the obligation rate at year-end closeout.
- Calculate the true obligation rate at the expired state of the appropriation.
- Determine the cause of adjustments.
- Review obligation documents for compliance.
- Ensure the accounting classification cited on the obligation document is appropriate for the stated purpose of the obligation.
- Ensure the amount obligated meets statutory and regulatory provisions.
- Ensure the obligation is recorded accurately and in a timely manner.
- Prepare for mandated joint reviews.

RULES OF OBLIGATION

H-1. **Additional guidance.** See DOD 7000.14-R, Volume 3, Chapters 8, 10, and 15 for information on rules of obligation not covered in this Appendix.

H-2. **Obligating current year funds for prior year needs.** Do not obligate current year funds for the needs of a prior year. If the prior year needs still exist in the current year, obligate current year funds to satisfy the “continuing need.” If an obligation had been incurred in the prior year, whether recorded or unrecorded, then prior year funds must be used to fund the prior year needs.

H-3. **Severable service contracts.** Obligate funds for the amount of the contract. The fund must be current for the year in which a severable service contract is signed, provided the contract does not exceed 12 months. Severable service contracts exceeding 12 months are funded by appropriations of the fiscal years in which the services are rendered. In accordance with 10 USC 2396, an exception to funding severable contracts exceeding 12 months with appropriations current when services are rendered, is allowed in foreign countries where laws and customs require advance payments.

Appendix H

H-4. **Option years are treated as new contracts.** When the severable service contract has renewal options, obligate funds for the basic period and for any penalty charges for failure to exercise options.

H-5. **Non-severable contracts.** Obligate funds current when a non-severable (also referred to as “entire” or “single entity”) contract is signed for the full amount of the contract. Non-severable contracts are for single undertakings in which the services to be received cannot be separated for performance in separate fiscal years. Training tends to be non-severable.

H-6. **Travel orders.** Cite the next FY’s appropriation on a temporary duty (TDY) order issued in the current FY for travel in the next FY. These orders must include a statement, “subject to availability of funds.” Do not record obligations for the next FY in the current FY. An exception for military personnel authorizes advance payments of certain PCS travel and transportation allowances according to 37 USC 303 of the Career Compensation Act of 1949. This pertains to do-it-yourself (DITY) moves. Charge all costs incurred before the date of release (for example, Service Member’s dependents traveling before release date) to the appropriation current at the time the payment is made, with a subsequent adjustment to the proper fiscal year (appropriation current in the month of relief). The only exception is the cost of non-temporary contract commercial storage of household goods, which is charged to the period during which the service is rendered.

H-7. **Procurement of information technology from the General Services Administration (GSA).** In accordance with 40 USC 1412(e), DOD activities may obtain information technology resources from GSA programs without relying on The Economy Act. The obligation is recorded at the time the activity enters into a binding written interagency agreement with GSA. There does not have to be a contract or task order in place because the interagency agreement itself is in the nature of a contract for the purpose of recording the obligation. The funds are available for the next fiscal year, even if GSA has not executed the interagency agreement prior to the end of the current fiscal year. New needs may not be added to an existing order and funded with expired funds unless deemed to be within the change scope of the original order.

H-8. **Supplies.** Record obligations for supply items when orders are placed. Ordering activities must modify or cancel open, unfilled requisitions before the appropriation can be closed. If ordering activities determine a bona fide need still exists for the supplies or equipment, they must request the requisition be modified to cite the current appropriation using military standard requisition and issue procedures (MILSTRIP) document modifier procedures. These adjustments are not subject to the limitations for canceled accounts.

H-9. Once the supply system is closed for the fiscal year, requisitions will not be processed. Exceptions to this policy (by pass authority) can be authorized only by sending a request through command channels to HQDA, Office of the G4 and receiving approval for the exception.

H-10. Use appropriated funds originally cited for MILSTRIP requisitions processed, or for local purchase orders—

- Placed to replace requisitions canceled or rejected for causes other than the requisitioner’s request for cancellation, or from his or her failure to respond to a materiel obligation validation (MOV) request. An exception is failure to respond to a MOV request (status code BS) due to administrative error; in this case, the purchase order may be reinstated for a period not to exceed 90 days.
- Issued by the original requisitioner or a substitute requisitioner funded for supply purchases from the same formal subdivision of funds (allocation or allowance/allotment) as the original requisitioner.
- Issued to re-requisition the original item or a suitable replacement item (for example, an interchangeable or substitute item identified in the Army Master Data File (AMDF)).
- Issued to satisfy a pre-existing and continuing bona fide need of the original or substitute requisitioner for the original replacement item.

- Issued to requisition materiel that is substantially of the same size and scope as the original requisition.
- Issued for replacement contracts when the original requisition is not canceled by a customer's request for cancellation or by the customer's failure to respond to a MOV request (including requisition cancellations with a status code of "BQ"). However, if a request for cancellation is submitted due to extenuating circumstances, due to no fault of the requisitioner, the resulting "BQ" may be re-utilized if other rules for re-utilization are met.

H-11. **Canceled Appropriations.** Appropriations canceled pursuant to 31 USC 1552, 1555, or 1557 are not available for new obligations. Adjustments may be made to canceled appropriations, provided the transaction being adjusted occurred before the appropriation was canceled. Canceling appropriations does not eliminate the Government's legal obligation to pay contractors for services rendered or products delivered, nor does it nullify the need for the accounting activity to maintain an audit trail for the existing contingent liability to future appropriations. See DFAS-IN Reg. 37-1, Chapter 16, and DOD 7000.14-R, Volume 3, Chapter 10, for limitations and additional guidance. Use unexpired funds available for the same general purpose to pay for obligations charged to the canceled account if done before the account canceled.

RECORDING OBLIGATIONS

H-12. When recording obligations—

- Record obligations in the accounting classification cited on the obligating document. If the accounting classification is in error, request an amendment or contract modification.
- Record obligation adjustments for the difference between actual and original amounts.
- Adjust obligations for written changes if they are binding on the contractor without further action.
- Record obligations providing for a discount at the net price unless it is not cost effective, according to Treasury guidelines. If the servicing accounting system automatically deobligates the amount of the discount when the discount is taken, then record the obligation at the gross amount.
 - Record estimates for return of materiel temporarily borrowed from Army Working Capital Fund—Supply Management, Army (AWCF-SMA) when items are returned. Adjust to actual cost when billing is received. For AWCF-SMA, obligate the minimum amount required for the period of the contract.
 - If the contract provides for annual terms with options to extend the terms in subsequent years, obligate for the amount required to be procured by the U.S. Government in the first year. Record the obligation for each option year when the option is exercised.
 - If the contract provides for minimum quantities over a period of more than one year, record the obligation for the sum of the minimum quantities times the agreed price. If the contract provides for minimum dollar amounts for more than one year, record the obligation for the sum of the minimum dollar amounts.
 - Estimate termination costs at least annually for contracts extending for more than one year. Record the obligation for the sum of the guaranteed minimum quantities or amounts unless the sum of the incurred cost and the estimated termination costs are determined to be a lesser amount. In that event, obligate the lesser amount of the incurred cost plus the estimated termination costs.

Appendix H

- Record international military education and training (IMET), and foreign military financing (FMF) funds as obligated when received by the Army. Adjust obligations to amounts shown on travel authorizations or validated orders when documents are received.

ESTIMATED OBLIGATIONS

H-13. Obligations may be recorded based on estimates. When actual obligation amounts become known, reverse and replace estimated obligations with actual obligations. The estimates and reversals are accomplished using DD Form 2406, (Miscellaneous Obligation Document (MOD)). Serviced activities and accounting activities will jointly ensure the actual obligation document is received to replace the MOD.

SIGNATURES ON OBLIGATION DOCUMENTS

H-14. When signatures are required to validate obligations, sign the documents before the cited funds expire. Show the actual date of each signature. When more than one signature is required, record the obligation on the date of the last required signature.

OBLIGATION DOCUMENTATION

H-15. Documentary requirements for recording obligations are provided in 31 USC 1501(a). The remainder of this section lists typical types of obligation documentation and also provides suggested ways to control and/or validate the information on the obligation document. Obligations may not be recorded without proper documentation.

DD Form 2406 (Miscellaneous Obligation Document (MOD))

H-16. DD Form 2406 can be used as a temporary obligating document for any EOR.

Personnel Compensation and Benefits (Excluding PCS Costs), EOR 2100

H-17. Typical obligation documents for personnel compensation and benefits (excluding PCS costs) are—

- Payroll systems output.
- DD Form 2406. This may be used to record estimated obligations for new employees, projected overtime for a specific pay period, lump-sum leave, personnel cost transfers, cash awards, and manual payroll costs.
- SF 50-B (Notification of Personnel Action).
- DA Form 1256 (Incentive Award Nomination and Approval).
- DA Form 2441 (Suggestion Award Certificate).

Personnel Compensation and Benefits Associated with PCS, EOR 2100

H-18. Typical obligation documents for personnel compensation and benefits associated with PCS are—

- DD Form 1614 (Request/Authorization for DOD Civilian Permanent Duty or temporary change of station (TCS) Travel).
- DD Form 2406. This form may temporarily be used in advance of formal documentation. However, formal documentation must follow within 30 days.

Compensation for Travel, Per Diem, and Transportation of Persons (Excluding PCS), EOR 2100

H-19. Typical obligation documents for compensating costs for travel, per diem, and transportation of persons (excluding PCS) are—

- DD Form 1610 (Request and Authorization for TDY Travel of DOD Personnel) manual or automated (Defense Travel System (DTS)).
- DD Form 652 (Meal Ticket).
- SF 1164 (Claim for Reimbursement for Expenditures on Official Business).
- SF 1169 (U.S. Government Transportation Request).
- SF 1034 (Public Voucher for Purchases and Services Other Than Personal).

H-20. Use the following standards to control/validate travel orders:

- Ensure there is a valid document reference number (DRN).
- Monitor document timeliness and maintain statistics by serviced activity.
- Monitor document quality for completeness and accuracy, returning those needing additional or corrected information. Maintain statistics on returned documents by serviced activity.
- File documents by the month travel commences if automated aging is based on accounting office's processing date.
- Validate accounting classifications including EORs to the purpose and scope of the orders (see DFAS-IN Manual 37-100-04).
- Ensure travel order costs crossing fiscal years are properly prorated. (*Note: A "subject to availability of funds" statement is required when spanning fiscal years.*)
- Obligate travel orders for transportation provided by the Air Mobility Command when received from the appropriate budget office. The accounting activity will use the DRN to maintain accountability pending receipt of the Air Mobility Command bill from the Air Force via cross-disbursing.

Transportation of Things (Except PCS Household Goods (HHG) Shipments), EOR 2200

H-21. Typical obligation documents for transporting things (except PCS household goods) are—

- SF 1103A (U.S. Government Bill of Lading—Memorandum Copy).
- SF 1203 (U.S. Government Bill of Lading—Privately Owned Personal Property).
- SF 1169.
- DD Form 1155 (Order for Supplies or Services). See figure H-9.
- DD Form 1348-1A (Issue Release/Receipt Document).

H-22. The following standards should be used to control/validate the obligation documents for transporting things (except PCS HHG shipments):

- Ensure there is a valid SDN.
- Ensure the transportation officer certifies all GBLs, demurrage, and detention documentation.
- Monitor timeliness of transportation documents.
- Ensure bulk fund cites to transportation officers are fully obligated and adjusted based on receipt of SF 1169.

Appendix H

Contracts, Various EORs

H-23. Typical obligation documents for contracts, by contract type, are—

- Leases and rentals.
 - DD Form 1155.
 - SF 33 (Solicitation, Offer, and Award).
 - SF 30 (Amendment of Solicitation/Modification of Contract).
 - DD Form 2406. This form may be used to record obligations for contracts having been let but for which hard copies have not been received. Upon receipt of the hard copy, reverse out the MOD and record the contract. See figures H-10 and H-11.
- Printing and publication, EOR 2400.
 - Government Printing Office (GPO) Form 2511 (Print Order).
 - GPO Form 1026A (Print Order for Marginally Punched Continuous Forms).
 - DD Form 282 (DOD Printing Requisition/Order).
 - SF 1 (Printing and Binding Requisition to the Public Printer).
- Communications and utilities, EOR 2300. The usual obligation document is DD Form 2406 pending receipt of contract or other permanent document.
- Reimbursable services, ARA for any EOR, obligation forms.
 - DD Form 448-2.
 - DD Form 1144 (Support Agreement).
 - Memorandum of agreement (MOA).
 - Memorandum of understanding (MOU).
- Types of purchase orders.
 - SF 33.
 - SF 30.
 - DD Form 1155.
 - SF 44.
- Types of delivery orders. Usually DD Form 1155.
- Miscellaneous contracts.
 - SF 1442 (Solicitation, Offer and Award (Construction, Alteration or Repair)).
 - SF 33.
 - SF 30.
 - DD Form 1556 (Request, Authorization, Agreement, Certification of Training and Reimbursement).
 - DD Form 448-2. When a direct fund cite is used, the performing activity provides a copy of the contract or other obligating document to the ordering activity. This provides the documentation required to record the obligation. If not using a direct fund cite, the ordering activity will obligate upon receipt of the accepted DD Form 448-2.
 - Letter Contracts or Letters of Intent.

Supplies and Materiel (Excluding AWCF-SMA)

H-24. Types of obligation documents used for supplies and materiel (excluding AWCF-SMA) are—

- DD Form 1155.
- SF 44.
- SF 33.
- SF 30.

H-25. The following standards should be used to control/validate obligating documents for supplies and materiel (excluding AWCF-SMA):

- Ensure there is a valid SDN.
- Record amounts net of discounts, if warranted.
- Ensure documents are properly certified and signed.
- Check unit amounts on orders for reasonableness. Contact activities on questionable items before processing.

Supplies and Materiel (AWCF-SMA)

H-26. Typical obligating documentation used for supplies and materials are—

- Obligation, accrual, and disbursement data created from the financial inventory accounting system interfacing with the consumer fund accounting system. This includes on-post customers.
- Obligation, accrual, and disbursement data from manual documents generated to supplement the various automated systems.

INSTRUCTIONS FOR RECORDING OBLIGATIONS

H-27. Tables H-1 through H-6 are quick reference charts for recording obligations.

Table H-1. Basis for Recording Obligations			
Contract Type	Appropriation Year	Basis for Recording Obligation	Obligation Amount ¹
1. Government Charge Card	Current	Historical	Estimated monthly purchases.
2. Cost Reimbursable	Current	Contract award	Full amount.
3. Cost-Plus-Fixed-Fee	Current	Contract award	Full amount of contract, including the fixed fee.
4. Cost-Plus-Incentive-Fee	Current	Contract award	Full amount of contract, including the incentive fee.
5. Cost-Plus-Award-Fee	Current	Contract award	Full amount of contract, not including the award amount. Obligate award when determined that award will be paid. Obligation for award is against same appropriation and FY used for contract.
6. Cost Reimbursable with Delivery Orders	Current	Contract award and deliver orders	Minimum liability of the U.S. Government when contract awarded. Obligate additional funds over minimum for each order when placed.
7. Firm Fixed Price	Current	Contract award	Full amount.
8. Firm Fixed Price with Escalation Clause	Current	Contract award	Target amount.

Appendix H

Table H-1. Basis for Recording Obligations			
Contract Type	Appropriation Year	Basis for Recording Obligation	Obligation Amount ¹
9. Indefinite Delivery, Indefinite Quantity	Current	Contract award and delivery orders	When contract is awarded, obligate minimum liability of U.S. Government. Obligate additional funds over minimum for each order when placed.
10. Indefinite Delivery, Definite Quantity	Current	Contract award	Full amount for quantity required in current year. ²
11. Job order contracts	Current	Contract award	Minimum liability of U.S. Government and delivery orders in excess of the minimum liability.
12. Letter contract	Current	Upon issuance	The amount of maximum legal liability. ³
13. Letter contract	Current	When definitized ⁴	Adjust the recorded obligation to equal the contract amount.
14. Non-severable contract. ⁵	Current	Contract award	Full amount unless restricted by other obligation rules.
15. Purchase order \$100,000 and less.	Current	Upon issuance	Full amount
16. Purchase order over \$100,000.	Current	Upon written acceptance or constructive acceptance based on delivery	Full amount
17. Requirements	Current	Delivery order	Amount of delivery order
18. Reserve officer training	Current/Next subject to fund availability	Completion of 45 day period during first year	Full amount of the contract for the academic year
19. Severable contracts: a. Contract for services not to exceed 12 months. b. Contract exceeds 12 months. ⁶	Current	Contract award	a. Full amount of contract. b. Amount necessary to fund contract to end of appropriation's life. Remainder of contract must be obligated with subsequent years' funding
20. Subscriptions/periodicals	Current	Contract award	Full Amount for subscription periods offered by the vendor ⁷
21. Time and material	Current	Contract award and delivery orders	Minimum liability of U.S. Government exclusive of permitted variations. Obligate additional funds for each delivery order when order is placed.
22. Training in a civilian institution when training begins and ends in the current FY	Current	Contract award	Full amount
23. Training in a civilian institution when training begins in the current FY but ends in the next FY	Current	Contract award	Full amount

Table H-1. Basis for Recording Obligations			
Contract Type	Appropriation Year	Basis for Recording Obligation	Obligation Amount ¹
24. Training in a civilian institution when all of the following conditions exist: ⁸ a. Training begins within the first 90 days of the next FY, and b. Training is not readily available from other sources, ⁹ and c. Institution requires a non-cancelable contract/advance payment before the end of the current FY to reserve a space in the course or to pay for instructors.	Current	Contract award	Full amount
Notes: 1 Obligate contracts net of discount unless system automatically reduces obligation when discount is taken. 2 Delivery is required in current FY but not necessarily deliverable by the contractor in the current FY. 3 Letter contracts are superseded upon definitization, and the total cost of the definitized contract, less either the actual costs incurred under the letter contract (when known), or the maximum legal liability permitted by the letter contract (when actual costs cannot be ascertained), is obligated against the appropriation current at the time the parties enter into the definitized contract. 4 Definitized means when the total contract costs are determined. 5 Non-severable contracts are for single undertakings. For example, painting a building. 6 Severable contracts, for purposes of performance, are continuing and recurring in nature, such as for rents or for performance of purely personal services with compensation fixed in proportion to the amount of work performed. 7 Per 31 USC 3324, this includes "charges for a publication printed or recorded in any way for the auditory or visual use of the agency." 8 Tuition payments can be made in advance during the current FY only if the obligation is also properly chargeable to the current FY. 31 USC 3324 specifically prohibits making advance payments to obtain discounts for obligations properly chargeable to the next year's funds. 9 Courses meeting this requirement are generally offered only once a year and options for similar courses meeting the same training requirement are not available.			

Table H-2. Obligations for Intra-Government Agreements	
If the obligation is for—	Obligate—
1. A project order, or an Economy Act	The amount of the order using funds when the performing agency accepts it.
2. An order to another military department accepted as direct citation procurement.	The contract or other obligating document citing ordering activity's current funds when received from the performing activity who issues/awards a contract or other obligating documents citing ordering activity's current funds, not when the MIPR is accepted. ^{1,2}
3. An order issued to another U.S. Government agency as required or authorized by law. ³	The amount of the order using funds current when the order is issued.

Appendix H

Table H-2. Obligations for Intra-Government Agreements	
If the obligation is for—	Obligate—
Notes:	
1 Required by law means orders must be placed with a particular agency. There are no other options. Authorized means there are other options for agencies (for example, the Economy Act is not the only authority—other statutory authority exists and may be used.) Agencies may place orders with other U.S. Government agencies, such as the GSA, or order through other channels.	
2 The performing activity will forward obligation documents to the issuing activity when the direct fund cite method is used. The issuing activity cannot obligate funds until these documents are received.	
3 If the amount of the contract or other obligating document is less than the amount on the MIPR, then obligate only the amount of valid obligations incurred; not the total amount cited on MIPR.	

Table H-3. Obligations for Civilian Personnel Services, Incentive Awards, and Severance Pay	
If the obligation is for—	Obligate—
1. civilian salaries, wages and fringe benefits, ¹	when earned including month-end accruals.
2. accrued annual leave, a. Non-WCF b. WCF	when leave is taken. when earned or advanced.
3. other items such as uniform allowances, incentive awards, allowances for foreign national employees (for example, seasonal bonuses)	in the month of entitlement. ²
4. lump sum for annual leave payment - non WCF,	funds current on the date of separation/retirement.
5. Voluntary Separation Incentive Program (VSIP) and Voluntary Early Retirement Authority (VERA),	funds current when employee accepts and signs the agreement.
6. severance pay and the employee is - a. a U.S. civilian paid from appropriated funds, b. a foreign national (non-U.S. citizen) paid from appropriated funds,	a. obligate for the amount when due and payable, regardless of when disbursed. b. obligate allowances as earned, on a pay-period by pay-period basis, based on the governing status of forces agreement (SOFA), Master Labor Agreement, or other host-nation agreement. ^{3, 4, 5}
Notes:	
¹ The obligation is usually based on the most recent pay period disbursement amount.	
² Obligate civilian personnel incentive awards in the month of entitlement. The month of entitlement is the month the final approving authority signs the incentive award. Payment of the award in the next fiscal year does not affect the timing of the obligation.	
³ Do not obligate appropriated funds for separation allowances earned by foreign national employees during periods of employment by nonappropriated fund instrumentalities (NAFIs).	
⁴ If a foreign national employee transfers from one Service component to another, then the losing component is liable for the accrued adjusted separation allowances up to the time of separation, including all subsequent fluctuations in the foreign currency exchange rate applicable to those funds accrued until transfer. The gaining Service is responsible for all other costs.	
⁵ If a foreign national employee transfers within DA, then the losing organization sends the gaining organization an SF 2806 (Individual Retirement Record (Civil Service Retirement System (CSRS))) stating the separation allowance that accrued to the employee from his/her date of employment to his/her date of transfer. The gaining organization becomes responsible for all severance pay earned.	

Table H-4. Obligations for Travel and Transportation	
<i>If the obligation is for—</i>	<i>Obligate—</i>
1. Temporary Duty (TDY)— a. transportation, b. per diem allowances and other reimbursable costs, c. under blanket travel orders with an indefinite itinerary,	not later than the month in which the travel begins for— a. the total estimated cost of the travel. 1 b. either the estimated costs on a monthly accrual basis, or the total estimate before the travel starts. 2,3 c. the estimate of travel expenses to be incurred in the month.
2. Permanent change of station (PCS) for— a. civilian personnel. b. military personnel.	funds current— a. when PCS orders are issued, includes reimbursable expenses such as estimates for per diem, real estate expenses, Relocation Income Tax Allowance (RITA), temporary subsistence, relocation services, or transportation requests and GBLs expected to be issued. b. on the effective date of the orders (Appendix A, Volume 1, JFTR). Includes the estimated costs of per diem; relocation allowance, travel and transportation of the Soldier, dependents, household goods (HHG); and privately owned vehicles (POV).
3. commercial storage of HHG involving more than one year due to PCS,	funds current in the FY service is rendered.
4. a U.S. Government bill of lading (GBL), and transportation is separate from the purchase contract, and the carrier accepts the property in a later FY,	expected cost of the transportation to be furnished from funds current when the carrier accepts the property.
Notes: 1 All other costs are obligated in the FY incurred, for example, if a POV is used, obligate funds current when travel is performed. This applies equally to an annual appropriation and the final year of a multi-year appropriation. 2 Use the latter method for TDYs of 30 days or less. 3 When started in one FY and finishing in another FY, obligate estimated costs to be incurred in each of the applicable FYs.	

Table H-5. Miscellaneous Rules	
<i>If the obligation is for—</i>	<i>Obligate—</i>
1. a valid loan agreement,	the amount of the loan to be made.
2. a loan guaranteed under 50 USC 2091,	the amount of the loan to be made when the guaranteeing agency buys the loan.
3. a grant or subsidy,	the actual amount of the grant or subsidy payable.
4. a liability under pending litigation, a. with a condemnation suit filed without a declaration of taking, 1 b. with a condemnation suit filed with a declaration of taking, 1	a written estimate of the liability that will result- a. based on a written legal determination. b. when the amount required to be deposited with a court under declaration is paid.

Appendix H

Table H-5. Miscellaneous Rules	
<i>If the obligation is for—</i>	<i>Obligate—</i>
5. a valid judgment,	funds current when the judgment is rendered, but not until payment is authorized.
6. a claim payable by law,	when the claim is approved. 2
7. other legal liabilities of the U.S. Government,	based on documentation or legal determination.
8. public utilities (that is, electricity, gas, water, telephone),	funds current in the month the billing period ends, even if the billing period is split between FYs.
9. IMET/FMF training orders,	funds current when either funded orders or valid travel authorizations are received. 3
10. interest-penalty charges under Prompt Payment Act (PPA),	funds available for administration of the program for which interest was incurred.
11. contract ratification	when the U.S. Government's liability was incurred.
12. a materiel requisition,	funds current when the requisition is submitted/placed by the area's servicing stock record officer.
13. settlement of a claim,	funds using the same obligation rules that would be used for normal contracts.
14. court/Armed Services Board of Contract Appeals judgment-(judgment includes monetary award and may also include interest).	funds current at the time of monetary award to reimburse the judgment fund. If sufficient current funds are not available, the next appropriation may be used. This will not result in an antideficiency violation. (63 Comp Gen 308, 1984).
15. contract litigation costs, if separately stated in the settlement agreement or as a result of judgment.	funds current at the time of settlement or award. (28 USC 2412 (D)(4)); 5 USC 504.
16. Liabilities evidenced by expenditure documents,	the amount of the invoice/bill paid. The invoice/bill may be used as the obligating document.
<p>Notes:</p> <p>1 "Declaration of taking" is a statement of intent to seize private property for public use under eminent domain (40 USC, Section 58a - 258e). If the declaration is filed after the determination is issued, adjust the original amount to amount stated in the determination.</p> <p>2 When final approval is required at a higher level than the funded installation and the amount approved exceeds the installation's available funds, defer recording the obligation until enough funds are received to cover the increased amount. This is not an antideficiency violation.</p> <p>3 Obligate funded IMET orders when received by training activities using funds cited on the order regardless of when the travel or training starts. Funded IMET orders cannot be used to obligate funds of succeeding FYs. Adjust obligations based on actual student input and travel/living costs.</p>	

Table H-6. Obligations for Adjustments	
<i>If adjustment is—</i>	<i>Then obligate—</i>
<p>1. a. to a contract with a commercial contractor or U.S. Government agency; or</p> <p>b. for increases or decreases resulting from decisions under Public Law 85-804 correcting mistakes or formalizing informal agreements (Federal Acquisition Regulation (FAR), Section 50.302-3); 2 or</p> <p>c. for contingent liabilities existing under indemnification or equitable adjustment clause; 3 or</p> <p>d. for discretionary cost increases in a cost reimbursement contract exceeding contractually stipulated ceilings and not based on an antecedent liability enforceable by the contractor, 4</p> <p>e. a within scope contract modification for a Defense Environmental Restoration program contract citing Defense Environmental Restoration Account (DERA) funds transferred to operation and maintenance, Army (OMA).</p>	<p>obligate one of the following as appropriate:</p> <p>(1) unexpired funds for contract changes requiring change-in-scope; or</p> <p>(2) funds cited on the original contract for changes resulting from price inflation, escalation increases, economic price adjustments, incentive fees, award fees, and similar adjustments. 1</p> <p>(3) original funds cited on the contract for "within scope" changes. If original funds are not available or have closed, obligate current funds.</p> <p>obligate one of the following -</p> <p>(1) for DERA contracts, the prior-year account that funded the original contract if funds remain in that account, or</p> <p>(2) for DERA contracts, the current appropriation account that is available for the same purpose as the account that funded the original contracts if no prior-year funds are available.</p>
<p>2. a. for a contract terminated for the convenience of the U.S. Government,</p> <p>b. for a contract terminated for convenience pursuant to a court order or a determination by other competent authority (such as a board of contract appeals, GAO, or the contracting officer) that the original award was improper, the appropriation originally cited may be used in a subsequent fiscal year to fund a replacement contract after consulting with legal counsel;</p>	<p>adjust the recorded obligation to anticipated settlement costs.</p> <p>obligate funds originally cited to fund a replacement contract, provided all the following conditions are met:</p> <p>(1) original contract was made in good faith;</p> <p>(2) a continuing bona fide need still exists for the goods or services ordered;</p> <p>(3) replacement contract is substantially of the same size and scope as the original contract;</p> <p>(4) replacement contract is awarded without undue delay on same basis as original contract; and</p>

Appendix H

Table H-6. Obligations for Adjustments	
<i>If adjustment is—</i>	<i>Then obligate—</i>
3. for a contract terminated due to contractor default,	obligate funds originally cited to fund a replacement contract, provided all the following conditions are met: (1) original contract was made in good faith; (2) a continuing bona fide need still exists for the goods or services ordered; (3) replacement contract is substantially of the same size and scope as original contract; (4) replacement contract is awarded without undue delay on the same basis as the original contract; and (5) replacement contract is awarded to a different contractor.
4. for a protest filed with GAO in connection with a solicitation for, proposed award of, or award of a contract,	obligate, (after final ruling is made on protest), funds available at the time the protest was filed with GAO, provided the contract is awarded within 90 working days after the ruling.
5. for an obligation covering liquidated damages,	recover the amount of liquidated damages deducted and withheld. 5
6. for an anticipated price reduction on a contract determined with a written agreement between the contracting officer and the contractor,	adjust the original obligation as necessary.
7. for a miscellaneous obligation document (MOD) used to record an estimated obligation (such as utility service), and later determined to be over or understated,	adjust obligations against the MOD using same year funds.
8. for a credit received for materiel return,	reduce the obligation to the allotment account current at the time the credit is granted. 6
9. a. required to make a payment for a recorded unliquidated obligation in a cancelled account; or b. required to make a payment for an unrecorded obligation in a cancelled account; or c. required to obligate for an unrecorded obligation in a cancelled account when clearing a disbursement properly made before the account cancelled, 7	use unexpired funds available for the same general purpose subject to the unexpended and 1 percent limitations.
Notes: 1. Contract changes citing expired funds require written documentation supporting these charges/adjustments as a legitimate use of expired appropriations. See paragraph 9-5r for documentation requirements. 2. Public Law 85-804 is the statute that authorizes making, amending, and modifying contracts to facilitate the national defense. 3. The allottee is responsible for covering the U.S. Government's contingent liability under the contract and for ensuring enough funds are available to cover net increases in obligations if the contingencies become actual liabilities when the formal contract supplement is signed.	

Table H-6. Obligations for Adjustments	
<i>If adjustment is—</i>	<i>Then obligate—</i>
<p>Notes:</p> <p>4. Discretionary cost increases that exceed contractually stipulated ceilings but do not change the contract scope are charged, when the discretionary increases are granted, to funds cited on the original contract if available and then to funds current. Once the election is made to use current year funds, subsequent accounting adjustments to transfer costs to prior years are not authorized.</p> <p>5. If a contractor objects to the deduction of liquidated damages, treat the amount as a contingent liability. Reestablish an obligation only when a formal contractor claim is approved.</p> <p>6. Maintain financial control over outstanding materiel returns to inventories. Account for returns as reversals of related materiel procurement and/or issue transactions.</p> <p>7. See procedures for adjustments in cancelled accounts in Chapter 16 for proper processing.</p>	

SAMPLE OBLIGATING DOCUMENTS

H-28. The following subparagraphs illustrate typical obligating documents. Instructions for completing the forms are also included.

DD Form 448, Military Interdepartmental Purchase Request

H-29. Figure H-1 shows a sample of completed DD Form 448. Table H-7 provides detailed instructions on completing the form.

Appendix H

MILITARY INTERDEPARTMENTAL PURCHASE REQUEST					1. PAGE 1 OF 1 PAGES				
2. FSC		3. CONTROL SYMBOL NO.		4. DATE PREPARED 15 November 2004		5. MIPR NUMBER MIPRSSI04TB013		6. AMEND NO. INT	
7. TO: General Services Administration Region 5 Attn: Bonnie Smith Data Services Division Chicago, IL 60604 (231) 654-5555 bonnie.smith@gsa.gov					8. FROM: (Agency, name, telephone number of originator) Commander U.S. Army Soldier Support Institute 10000 Hampton Parkway Attn: CPT J. Doe Fort Jackson, SC 29207 (803) 751-8658 Email: j.doe@jackson.army.mil				
9. ITEMS <input type="checkbox"/> ARE <input type="checkbox"/> ARE NOT INCLUDED IN THE INTERSERVICE SUPPLY SUPPORT PROGRAM AND REQUIRED INTERSERVICE SCREENING <input type="checkbox"/> HAS <input type="checkbox"/> HAS NOT BEEN ACCOMPLISHED.									
ITEM NO. <i>a</i>	DESCRIPTION <i>(Federal stock number, nomenclature, specification and/or drawing No., etc.)</i> <i>b</i>				QTY <i>c</i>	UNIT <i>d</i>	ESTIMATED UNIT PRICE <i>e</i>	ESTIMATED TOTAL PRICE <i>f</i>	
1	Prepare and deliver an automation package in Windows format to provide supply ordering, processing, and monitoring for a classroom environment. Not to exceed MIPR amount unless authorized by POC. This Economy Act order is placed in accordance with the provisions of DFAS-IN 37-1/DODFMR, Volume 11. Request all billings be sent to: See Block# 8 POC for this order is CPT J.Doe, Commercial (803) 751-8658 DSN: 734-8658 Email: j.doe@jackson.army.mil				1		\$225,000.00	\$225,000.00	
10. SEE ATTACHED PAGES FOR DELIVERY SCHEDULES, PRESERVATION AND PACKAGING INSTRUCTIONS, SHIPPING INSTRUCTIONS AND INSTRUCTIONS FOR DISTRIBUTION OF CONTRACTS AND RELATED DOCUMENTS.								11. GRAND TOTAL \$225,000.00	
12. TRANSPORTATION ALLOTMENT (Used if FOB Contractor's plant)					13. MAIL INVOICES TO (Payment will be made by) DFAS-Rome 325 Brooks Road, Rome, NY 13441-4527 PAY OFFICE DODAAD W537RQ				
14. FUNDS FOR PROCUREMENT ARE PROPERLY CHARGEABLE TO THE ALLOTMENTS SET FORTH BELOW, THE AVAILABLE BALANCES OF WHICH ARE SUFFICIENT TO COVER THE ESTIMATED TOTAL PRICE.									
ACRN	APPROPRIATION	LIMIT/SUBHEAD	SUPPLEMENTAL ACCOUNTING CLASSIFICATION				ACCTG STA DODAAD	AMOUNT	
	2142020	0000	57-8307 325796.BD 252G TA44 MIPRSSI04TB013 SFIN S12011				W4RNAA	\$225,000.00	
15. AUTHORIZING OFFICER (Type name and title) James A. Doe, Budget Officer					16. SIGNATURE			17. DATE 15 November 2004	
DD Form 448, JUN 72 (EG)					PREVIOUS EDITION IS OBSOLETE.				

Figure H-1. Sample of Completed DD Form 448

Table H-7. Instructions for Completing DD Form 448, Military Interdepartmental Purchase Request	
Item	Instructions
(1)	Block 1. Enter number of pages (includes attachments).
(2)	Block 2. FSC. Enter Federal supply classification, if applicable.
(3)	Block 3. CONTROL SYMBOL NO. Enter control symbol number, if applicable.
(4)	Block 4. DATE PREPARED. Enter the date MIPR is prepared. For amendments, enter the date the amendment is prepared.
(5)	Block 5. MIPR NUMBER. Enter MIPR number, which is also the SDN for a MIPR.
(6)	Block 6. AMED NO. Enter the amendment number of the MIPR. On issuance of the first MIPR, enter "INITIAL". Consecutively number future amendments to the MIPR starting with 01.
(7)	Block 7. TO. Enter the complete address of the agency/activity that will be accepting the MIPR, telephone number and email address.
(8)	Block 8. FROM. Enter the complete address of the agency/activity that is ordering the work/services/supplies, telephone number and email address.
(9)	Block 9. Check the appropriate blocks.
(10)	Block 9, Column a. ITEM NO. Enter the item number that relates to the description. If the MIPR is requesting more than one type of item of work/service, consecutively number each item.
(11)	Block 9, Column b. DESCRIPTION. Enter the description of work/services being requested, the appropriate statement if order is an Economy Act order or a Project Order, and a point of contact (POC), telephone number and email address. For amendments, explain reason for increase/decrease.
(12)	Block 9, Column c. QTY. Enter quantity, if applicable.
(13)	Block 9, Column d. UNIT. Enter unit of issue, if applicable.
(14)	Block 9, Column e. ESTIMATED UNIT PRICE. Enter estimated unit price. For amendment, enter amount of increase/decrease.
(15)	Block 9, Column f. ESTIMATED TOTAL PRICE. Enter estimated total price (quantity X estimated unit price). For amendment, enter amount of increase/decrease.
(16)	Block 10. Self-explanatory.
(17)	Block 11. Enter the grand total of the MIPR. For amendments, enter revised grand total (original amount plus/minus amended amount).
(18)	Block 12. TRANSPORTATION ALLOTMENT. Enter transportation accounting classification if free on board (FOB) contractor's plant.
(19)	Block 13. MAIL INVOICES TO. Enter the address and DOD Activity Address Directory (DODAAD) of the (field site)/DFAS that supports the ordering activity. Bills will be sent to the Field Site/DFAS that supports the ordering activity. Ordering activities may request "copies" of bills with supporting detail to be provided if so stated on the MIPR and agreed to by the performing activity.
(20)	Block 14. Enter the requested information in the appropriate columns.
(21)	Block 14, Column 1. Enter the accounting classification reference number (ACRN) in reference number block, if applicable. In the following blocks enter the "billed to" accounting classification. If additional space is required for additional fund citations, provide in an attachment to the MIPR and make reference to the attachment on the form. In the supplemental accounting classification block, include the SDN, which is the same as the MIPR number in block 5. For amendments, enter amount of increase/decrease.

Appendix H

Table H-7. Instructions for Completing DD Form 448, Military Interdepartmental Purchase Request	
Item	Instructions
(22)	Block 14, Column 2. APPROPRIATION.
(23)	Block 14, Column 3. LIMIT/SUBHEAD.
(24)	Block 14, Column 4. SUPPLEMENTAL ACCOUNTING CLASSIFICATION. In the supplemental accounting classification block, include the SDN, which is the same as the MIPR number in block 5.
(25)	Block 14, Column 5. ACCTG STA DODAAD.
(26)	Block 14, Column 6. AMOUNT.
(27)	If additional space is required for additional fund citations, provide in an attachment to the MIPR and make reference to the attachment on the form. In the supplemental accounting classification block, include the SDN, which is the same as the MIPR number in block 5. For amendments, enter amount of increase/decrease.
(28)	Block 15. AUTHORIZING OFFICER. Enter the authorizing officer name (typed or printed).
(29)	Block 16. SIGNATURE. The authorizing officer will sign here. Electronic signature is authorized.
(30)	Block 17. DATE. Enter the date the MIPR is signed. For amendments, enter the date the amendment is signed.

DD Form 448-2

H-30. Figure H-2 shows a sample of completed DD Form 448-2. Table H-8 provides detailed instructions on completing the form.

ACCEPTANCE OF MIPR					
1. TO (Requiring Activity Address)(Include ZIP Code) Commander U.S. Army Soldier Support Institute 10000 Hampton Parkway Phone: Commercial (803)751-8658			2. MIPR NUMBER MIPRSSI04TB013		3. AMENDMENT NO. INT
			4. DATE (MIPR Signature Date) 15 November 2004	5. AMOUNT (As Listed on the MIPR) \$225,000.00	
6. The MIPR identified above is accepted and the items requested will be provided as follows: (Check as Applicable)					
a. <input checked="" type="checkbox"/> ALL ITEMS WILL BE PROVIDED THROUGH REIMBURSEMENT (Category I)					
b. <input type="checkbox"/> ALL ITEMS WILL BE PROCURED BY THE DIRECT CITATION OF FUNDS (Category II)					
c. <input type="checkbox"/> ITEMS WILL BE PROVIDED BY BOTH CATEGORY I AND CATEGORY II AS INDICATED BELOW					
d. <input type="checkbox"/> THIS ACCEPTANCE, FOR CATEGORY I ITEMS, IS QUALIFIED BECAUSE OF ANTICIPATED CONTINGENCIES AS TO FINAL PRICE. CHANGES IN THIS ACCEPTANCE FIGURE WILL BE FURNISHED PERIODICALLY UPON DETERMINATION OF DEFINITIZED PRICES, BUT PRIOR TO SUBMISSION OF BILLINGS.					
7. <input type="checkbox"/> MIPR ITEM NUMBER(S) IDENTIFIED IN BLOCK 13, "REMARKS" IS NOT ACCEPTED (IS REJECTED) FOR THE REASONS INDICATED.					
8. TO BE PROVIDED THROUGH REIMBURSEMENT CATEGORY I			9. TO BE PROCURED BY DIRECT CITATION OF FUNDS CATEGORY II		
ITEM NO. a.	QUANTITY b.	ESTIMATED PRICE c.	ITEM NO. a.	QUANTITY b.	ESTIMATED PRICE c.
1	1	225,000.00			
d. TOTAL ESTIMATED PRICE		225,000.00	e. TOTAL ESTIMATED PRICE		
10. ANTICIPATED DATE OF OBLIGATION FOR CATEGORY II ITEMS			11. GRAND TOTAL ESTIMATED PRICE OF ALL ITEMS 225,000.00		
12. FUNDS DATA (Check if Applicable)					
a. <input type="checkbox"/> ADDITIONAL FUNDS IN THE AMOUNT OF \$ _____ ARE REQUIRED (See justification in Block 13)					
b. <input type="checkbox"/> FUNDS IN THE AMOUNT OF \$ _____ ARE NOT REQUIRED AND MAY BE WITHDRAWN					
13. REMARKS POC for acceptance of this order is Harry Handie, Commercial (231) 654-5551 Email: harry.handie@gsa.gov					
14. ACCEPTING ACTIVITY (Complete Address) General Services Administration Region 5 Attn: Bonnie Smith Data Services Division			15. TYPED NAME AND TITLE OF AUTHORIZED OFFICIAL Bonnie Smith, Budget Analyst		
			16. SIGNATURE		17. DATE 15 November 2004
DD FORM 448-2, JUL 71			PREVIOUS EDITION WILL BE USED UNTIL EXHAUSTED.		

Figure H-2. Sample of Completed DD Form 448-2

Appendix H

Table H-8. Instructions for Completing DD Form 448-2, Acceptance of MIPR

<i>Item</i>	<i>Instructions</i>
(1)	Enter the address and telephone number of the ordering activity. Address will be the same as that entered on block 8 of the DD Form 448.
(2)	Enter the MIPR number. This number will be the same as entered on block 5 of DD Form 448.
(3)	Enter the amendment number. This number will be the same as entered on block 6 of DD Form 448.
(4)	Enter the signature date. This date will be the same date as entered on block 17 of DD Form 448.
(5)	Enter the amount as entered on block 11 of DD Form 448.
(6)	Check the appropriate block.
(7)	Check, if applicable, and enter comment/reasons in block 13.
(8)	In blocks 8a through 8c (self-explanatory), enter the appropriate data if accepted through reimbursement. For amendments, in blocks 8c-8d, enter amount of increase/decrease.
(9)	In blocks 9a through 9c (self-explanatory), enter the appropriate data if accepted as a direct fund cite. It is recommended that the ordering activity issue a message/letter using a direct fund cite instead of the MIPR. For amendments, in blocks 9c-9d, enter amount of increase/decrease.
(10)	Self-explanatory.
(11)	Enter the grand total of MIPR. If grand total is different than that on DD Form 448, block 11, notify the ordering activity. This will require an amendment. For amendments, enter revised grand total (original amount plus/minus amended amount).
(12a)	Check block, if applicable, and enter the additional dollar amount needed. Show justification in block 13.
(12b)	Check block, if applicable, and enter amount that is no longer required and to be withdrawn by the ordering activity. When this block is filled out and returned to the ordering activity, no change orders are required by the ordering activity. Upon receipt of DD Form 448-2 and block 12b is checked and amount shown, adjust obligations accordingly.
(13)	Enter remarks, if applicable. Enter the appropriate statement if order is an Economy Act order or a Project Order and a POC with their telephone number and email address.
(14)	Enter the complete address of the accepting (performing) activity.
(15)	Enter the typed/printed name of the authorized official that is accepting the order.
(16)	The authorized official accepting the order will sign here.
(17)	Enter date that DD Form 448-2 is signed.

Memorandum of Agreement

H-31. Figure H-3 shows a sample of a completed memorandum of agreement (MOA).

<p>MEMORANDUM OF AGREEMENT</p> <p>BETWEEN</p> <p>THE (name the other Federal agency/Service) AND THE U.S. DEPARTMENT OF THE ARMY FOR REIMBURSING THE U.S. ARMY FOR (name the service/agreement/ requirements).</p> <p>I. Purpose. This agreement establishes the financial arrangements between the (name the other Federal agency) and the Department of the Army for reimbursing the Department of the Army for (identify the program).</p> <p>II. Description of Services to be Provided. The Department of the Army is to maintain the capability to respond on an as-required basis to the (identify the other Federal agency) requirements for (describe the required support) and to meet the needs of the (name the other Federal agency) that has limited (identify the support) capabilities.</p> <p>III. Basis for Reimbursement.</p> <p>A. This agreement is entered into under the provisions of (identify the authority, such as the "Economy Act") and provides for a reimbursable order of approximately (identify the dollar amount). This MOA is subject to annual modification as necessary to provide for reimbursement of costs as described below in providing the requested support. The amounts in respective reimbursable orders may not be exceeded by more than (display the ceiling by either a percentage or dollar value) without written approval by the (name the other Federal agency).</p> <p>B. Support furnished under this agreement shall be for the costs incurred by the Department of the Army in providing the services.</p> <p>IV. Procedural Arrangements.</p> <p>A. Estimating. The Department of the Army will continuously review its actual costs incurred in providing the requested support to ascertain if they are in line with the annual cost estimates. The Department of the Army will promptly advise the (name the other Federal agency) of any required revisions to the value of this agreement.</p> <p>B. Ordering. The (name the other Federal agency) will provide a completed order for specific materiel or services to the Department of the Army for acceptance and the identification of the (name the other Federal agency) accounting data for resulting billings (unless a check is provided in advance). The delivery requirements of the (name the other Federal agency) will be stated in the order.</p> <p>C. Billing. The Department of the Army will bill the (name the other Federal agency) on a monthly basis by submitting SF 1080 (Voucher for Transfers Between Appropriations and/or Funds) and including a breakdown of actual cost elements being reimbursed. The voucher shall be sent or delivered to the (name the other Federal agency) within 30 days after the month in which the transaction occurred.</p> <p>D. Payment of Bills. The (name the other Federal agency) paying office will forward check payment along with a copy of the billed invoice to the appropriate addressee listed on the billing invoice within 30 days of the date of invoice (unless identified as no check required). Bills rendered are not subject to audit.</p> <p>V. Effective Date. This agreement is effective (insert date) and will terminate on (insert date). (name the other Federal agency/Service) (name the Army component)</p>

Figure H-3. Sample Memorandum of Agreement

Appendix H

ORDER NO.		DATE OF DELIVERY	ARTICLE OR SERVICES	QUANTITY	UNIT PRICE		AMOUNT
					COST	PER	DOLLARS AND CENTS
MIPR-IA0294			Transportation expenses for John Doe from Savannah, GA to Indianapolis, IN and return. At the request of District Engineer Savannah in conjunction with reimbursable order.				516.29
TOTAL							516.29
Remittance in payment hereof should be sent to -- Department of the Army, Division of Financial Management Office Finance Operations (Tel #555-4567) Indianapolis, IN 42649-0001							
ACCOUNTING CLASSIFICATION -- <i>Office Receiving Funds</i>							
2192020.000 38-8301 878716.60 211J MIPRCOEIA0294F AY33 S12102							
CERTIFICATE OF OFFICE CHARGED							
I certify that the above articles were received and accepted or the services performed as stated and should be charged to the appropriation(s) and/or fund(s) as indicated below; or that the advance payment requested is approved and should be paid as indicated.							
		13 Jan 20** (Date)	Mary Doe (Authorized administrative or certifying officer) Chief of Financial Services (Title)				
ACCOUNTING CLASSIFICATION -- <i>Office Charged</i>							
96X3124, GE, CE, Civil EA6026100008803 (DA) S96490							
Paid by Check No.		123456789					
NSN 7540-00-634-4230 Previous Editions Are Usable USAPPC V3.00							

Figure H-4. Sample of Completed SF 1080

SF 1080

H-32. Figure H-4 shows a sample of completed SF 1080. Table H-9 provides detailed instructions on completing the form.

Table H-9. Instructions for Completing SF 1080		
Item	Block Title	Instructions
(1)	Department, Establishment, Bureau, or Office Receiving Funds	Office, department establishment, or bureau receiving funds.
(2)	Department Establishment, Bureau, or Office Charged	Address of the office charged-should be address of OPLOC/DFAS supporting the ordering activity.
(3)	Order Number	MIPR number, reimbursable order number, delivery order number, and so forth.
(4)	Date of Delivery	Date of delivery, if applicable.
(5)	Article or Service	Description of services or itemization of bill, date of bill, payment due date.
(6)	Quantity	Quantity, if applicable.
(7)	Unit Price	Unit price, cost per unit.
(8)	Amount	Amount.
(9)	Total	Unit price cost, total, if applicable.
(10)	Remittance in Payment hereof should be sent to—	Address where remittance/payment is to be sent. Provide a telephone number and the payment due date in this block.
(11)	Accounting Classification— Office Receiving Funds	Accounting classification of the performing activity.
(12)	Certificate of Office Charged	Certification statement of office charged-original signature required.
(13)	Accounting Classification— Office Charged	Accounting classification of ordering activity.
(14)	Paid By Check No.	Check number of check provided by the remitter.
(15)	Voucher No.	Voucher number-provided when check payment is made.
(16)	Schedule No.	Voucher schedule number-internal to the disbursing office.
(17)	Bill No.	Bill number of the SF 1080.

DD Form 1610

H-33. Figures H-5 and H-6 show samples of completed DD Form 1610. Table H-10 is a guide sheet for completing the form.

Appendix H

REQUEST AND AUTHORIZATION FOR TDY TRAVEL OF DOD PERSONNEL <i>(Reference: Joint Travel Regulations (JTR), Chapter 3) (Read Privacy Act Statement on back before completing form.)</i>										1. DATE OF REQUEST (YYYYMMDD) 12 Jun 03			
REQUEST FOR OFFICIAL TRAVEL													
2. NAME <i>(Last, First, Middle Initial)</i> Jon Doe			3. SOCIAL SECURITY NUMBER 111111111			4. POSITION TITLE AND GRADE/RATING Concepts Officer CPT							
5. LOCATION OF PERMANENT DUTY STATION (PDS) Fort Jackson, SC 29207					6. ORGANIZATIONAL ELEMENT SSI, Finance School			7. DUTY PHONE NUMBER <i>(Include Area Code)</i> 803751-8634					
8. TYPE OF AUTHORIZATION			9. TDY PURPOSE <i>(See JTR, Appendix H)</i> ROTC Visit 24-26 June 03 Fort Lewis, WA			10a. APPROX. NO. OF TDY DAYS <i>(Including travel time)</i> 4			b. PROCEED DATE (YYYYMMDD) 23 June 03				
11. ITINERARY From residence (Columbia SC) to Fort Lewis, WA and return													
12. TRANSPORTATION MODE													
a. COMMERCIAL				b. GOVERNMENT			c. LOCAL TRANSPORTATION						
RAIL	AIR	BUS	SHIP	AIR	VEHICLE	SHIP	CAR RENTAL	TAXI	OTHER	PRIVATELY OWNED CONVEYANCE <i>(Check one)</i>			
	X						X			RATE PER MILE: _____			
AS DETERMINED BY APPROPRIATE TRANSPORTATION OFFICER <i>(Overseas Travel only)</i>										ADVANTAGEOUS TO THE GOVERNMENT			
										MILEAGE REIMBURSEMENT AND PER DIEM IS LIMITED TO CONSTRUCTED COST OF COMMON CARRIER TRANSPORTATION AND PER DIEM AS DETERMINED AND TRAVEL TIME AS LIMITED PER JTR			
13.	X	a. PER DIEM AUTHORIZED IN ACCORDANCE WITH JTR.					b. OTHER RATE OF PER DIEM <i>(Specify)</i>						
14. ESTIMATED COST													
a. PER DIEM \$ 400.00			b. TRAVEL \$ 520.00			c. OTHER \$			d. TOTAL \$ 920.00			15. ADVANCE AUTHORIZED \$	
16. REMARKS <i>(Use this space for special requirements, leave, excess baggage, accommodations, registration fees, etc.)</i> To support your caim, demand from lodging host a paid receipt with claim. Travler does / does not have credit card Government Quarters and meals are not available: SNA 111111 Official Phone Calls are authorized													
17. TRAVEL-REQUESTING OFFICIAL <i>(Title and signature)</i> Mike Michaels, LTC Director DPCDD						18. TRAVEL-APPROVING/DIRECTING OFFICIAL <i>(Title and signature)</i> Jane Doe, Deputy Commandant							
AUTHORIZATION													
19. ACCOUNTING CITATION 213020 0110 37-1005 3147237 034 21t2 / \$520													
20. AUTHORIZING/ORDER-ISSUING OFFICIAL <i>(Title and signature)</i> For the commander: Ray A. Lewis, Chief PROG & Budget DIV, HQ Cadet Command								21. DATE ISSUED (YYYYMMDD) 20030612					
								22. TRAVEL AUTHORIZATION NUMBER 23-246					

DD FORM 1610, MAY 2003

PREVIOUS EDITION IS OBSOLETE.

Figure H-5. Sample of Completed DD Form 1610 Prepared for an Individual (Front)

PRIVACY ACT STATEMENT <i>(5 U.S.C. 552a)</i>	
AUTHORITY: 5 U.S.C. §§5701, 5702, and E.O. 9397.	
PRINCIPAL PURPOSE(S): Used for reviewing, approving, and accounting for official travel. SSN is used to maintain a numerical identification system for individual travelers.	
ROUTINE USE(S): None.	
DISCLOSURE: Voluntary; however, failure to provide the requested information may delay or preclude timely authorization of travel request.	
16. REMARKS <i>(Continued) (Use this space for special requirements, leave, excess baggage, accommodations, registration fees, etc.)</i>	

DD FORM 1610 (BACK), MAY 2003

Figure H-6. Sample of Completed DD Form 1610 Prepared for an Individual (Back)

Appendix H

Table H-10. Instructions for Completing DD Form 1610	
<i>Item</i>	<i>Instructions</i>
(1)	Block #1 – DATE OF REQUEST. Current date.
(2)	Block #2 - NAME: Traveler's last name, first name, and middle initial. For travel of two or more persons (using the same DD Form 1610), state, "See continuation sheet" and attach a continuation sheet with all traveler's standard name line.
(3)	Block #3 - SOCIAL SECURITY NUMBER
(4)	Block #4 - POSITION TITLE AND GRADE OR RATING: Enter grade/rank and position title. For DA Civilian, enter the pay grade and position title.
(5)	Block #5 - LOCATION OF PERMANENT DUTY STATION (PDS): Enter unit or organization station to include the location and zip code.
(6)	Block #6 - ORGANIZATIONAL ELEMENT: Enter the unit assignment.
(7)	Block #7 – DUTY PHONE NUMBER: Enter the duty phone number of the individual most knowledgeable of the TDY requirement for follow-up questions.
(8)	<p>Block #8 - TYPE OF AUTHORIZATION: Enter "TDY, AMENDMENT, BLANKET OR GROUP, ORAL ORDERS, or REVOCATION" as required.</p> <p>Amendments—Amendments are used to reflect changes to the original travel order. Amendment orders must reflect the original travel order requiring the amendment and all previous amendments, in block #16 (i.e. "TRAVEL ORDER NUMBER 01-010, DATED 23 JAN 99 IS AMENDED TO AUTHORIZE RENTAL CAR.")</p> <p>Oral Orders—When travel occurs prior to orders being issued, Oral orders must state Verification Order Commanding Officer "VOCO" in Block 7. This implies the traveler received a verbal approval to perform the travel from the approving authority, prior to conducting travel.</p> <p>Revocations—Revocations cancel an order. For revocations or rescissions to travel orders, block #8 will be completed, respectively. When a revocation is processed, reference in block #16 the original travel order being revoked and all previous amendments must be also be referenced (that is, TRAVEL ORDER NUMBER 02-015, DATED 25 FEB 99, and amendment travel order number #02-031 dated 28 FEB 99 ARE REVOKED DUE TO CANCELLATION OF TDY). Revocation completely nullifies the travel order.</p>
(9)	<p>Block #9. TDY PURPOSE: Ensure that—</p> <p>a. The mission requires the physical presence of individual(s) at itinerary location(s).</p> <p>b. The number of travelers is consistent with related factors of technical complexity, performance milestones, or prescribed attendance.</p>
(10)	<p>Block #10a. APROX. NO. OF TDY DAYS: Ensure that dates do not exceed elapsed time to complete assignment (with impact on advances), and minimize unproductive TDY on weekends and holidays.</p> <p>Block #10b. PROCEED DATE: The date to begin official travel.</p>

Table H-10. Instructions for Completing DD Form 1610	
<i>Item</i>	<i>Instructions</i>
(11)	<p>Block #11. ITINERARY: Ensure that—</p> <p>a. The military installation is shown as place of TDY when appropriate (with impact on use of quarters).</p>
(12)	<p>Block #12. TRANSPORTATION MODE: Ensure that—</p> <p>a. Costs are based on use of scheduled airline ticket office or transportation office for travel arrangements.</p> <p>b. The POC authorization does not increase Government costs over other practical transportation.</p> <p>c. Per diem supports a realistic number of days and, when appropriate, use of Government quarters.</p> <p>d. The authorized advance is supported by realistic cost estimates. Also, determine whether the traveler has a Government credit card.</p>
(13)	<p>Block#14. ESTIMATED COST: (refer to joint Federal travel regulation for per diem & other costs): Ensure that—</p> <p>a. Costs are based on the use of the scheduled airline ticket office or transportation office for travel arrangements.</p> <p>b. The POC authorization does not increase Government costs over other practical transportation.</p> <p>c. Per diem supports a realistic number of days and, when appropriate, use of Government quarters.</p> <p>d. The authorized advance is supported by realistic cost estimates. Also, determine whether the traveler has a Government credit card.</p>
(14)	<p>Block #16. REMARKS: Ensure that—</p> <p>a. The rental car authorization is consistent with a need for local travel at the TDY location, realities of public transportation, cost of taxi service, and number of travelers.</p> <p>b. Exceptions such as “use of existing Government facilities would adversely affect the performance of the assigned mission” are traceable to support.</p> <p>c. Special authorization for travel advance, taxi, extra baggage, and so forth, are traceable to support.</p> <p>d. Multiple choice and number-coded travel options are prohibited.</p> <p>e. Government transportation request costs are shown if the POV is not authorized. When the Air Mobility Command cost is the appropriate cost to the Government for overseas travel, ensure that the Air Mobility Command cost is shown instead of the Government transportation request cost.</p> <p>f. The following statement is present: “Travelers to the National Capital Region must contact the lodging success center before making lodging arrangements.”</p>

Appendix H

Table H-10. Instructions for Completing DD Form 1610	
<i>Item</i>	<i>Instructions</i>
(15)	<p>Blocks #17, TRAVEL REQUESTING OFFICIAL; 18, TRAVEL APPROVING/DIRECTING OFFICIAL; 19, ACCOUNTING CITATION; and 20, AUTHORIZING/ORDER-ISSUING OFFICIAL</p> <p>Authorizing Official:</p> <ul style="list-style-type: none"> a. Officials who can request, approve, and authorize TDY orders are formally designated. b. Item 19: Funds are certified and signed by designated representative in the budget office. It includes the DSSN of the office that maintains the traveler's DD Form 1588 (Record of Travel Payments). c. The fund site is traceable to approved travel funds.

DA Form 3953

H-34. Figures H-7 and H-8 show a sample of completed DA Form 3953 (Purchase Request and Commitment). Table H-11 provides detailed instructions on completing the form. For RM operations, this is a commitment document only. The return document sent from the directorate of contracting, DD Form 1155, is the actual obligation document.

PURCHASE REQUEST AND COMMITMENT <small>For use of this form, see AR 37-1; the proponent agency is OASD(FM)</small>		1. PURCHASE INSTRUMENT NO. BYGLGBPRC11023	2. REQUISITION NO. BYGLGBPRC11023	3. DATE 15 NOV 04	PAGE 1 OF 1 PAGES
4. TO: Directorate of Contracting Attn: Sandra Kyme Fort Jackson, SC 29207		5. THRU: ACoS, RM Soldier Support Institute Fort Jackson, SC 29207		6. FROM: S4 Recruiting and Retention School Fort Jackson, SC 29207	
It is requested that the supplies and services enumerated below or on attached list be					
7. PURCHASED FOR Classroom Improvement Project		8. DELIVERED TO Room 405, BLDG 10,000 Hampton Parkway Fort Jackson, SC 29207		9. NOT LATER THAN (Date) 20 Dec 04	
The supplies and services listed below cannot be secured through normal supply channels or other Army supply sources in the immediate vicinity, and their procurement will not violate existing regulations pertaining to local purchases for stock, therefore, local procurement is necessary for the following reason: (Check appropriate box and complete item.)					
12. LOCAL PURCHASES AUTHORIZED AS THE NORMAL MEANS OF SUPPLY FOR THE FOREGOING BY		13. REQUISITIONING DISCLOSES NONAVAILABILITY OF ITEMS AND LOCAL PURCHASE IS AUTHORIZED BY CTA, 50-9		11. TELEPHONE NUMBER 751-8659	
EMERGENCY SITUATION PRECLUDES USE OF REQUISITION CHANNELS FOR SECURING ITEM					
14. ITEM	15. DESCRIPTION OF SUPPLY OR SERVICES	16. QUANTITY	17. UNIT	18. ESTIMATED UNIT PRICE ^a	TOTAL COST ^b
1	Chair, office, roll away Model SK 42709B at Circuit City	32	32	\$44.00	\$1,408.00
19. ACCOUNTING CLASSIFICATION AND AMOUNT 21420200000 315011.00 26GB QNON BVGLGBPRC11023 RREC W4RRET S12011					
20. TYPED NAME AND TITLE OF CERTIFYING OFFICER J. Doc, CPT, Budget Officer		21. SIGNATURE		22. DATE 15 NOV 04	
23. DISCOUNT TERMS					
24. PURCHASE ORDER NUMBER					
26. DELIVERY REQUIREMENTS					
ARE MORE THAN 7 DAYS REQUIRED TO INSPECT AND ACCEPT THE REQUESTED GOODS OR SERVICES YES <input type="checkbox"/> NO <input type="checkbox"/>					
IF YES, NUMBER OF DAYS REQUIRED					
27. TYPED NAME AND GRADE OF INITIATING OFFICER Harry Salesman, SFC		28. SIGNATURE		29. DATE 15 NOV 04	
30. TELEPHONE NUMBER 751-8659		31. TYPED NAME AND GRADE OF SUPPLY OFFICER Jon Q. Pulbix, CPT		32. SIGNATURE	
33. DATE 15 NOV 04		34. TYPED NAME AND GRADE OF APPROVING OFFICER OR DESIGNEE		35. SIGNATURE	
36. DATE		37. DATE			

USIPPC V2.00

EDITION OF AUG 76 IS OBSOLETE

DA FORM 3953, MAR 91

Figure H-7. Sample of Completed DA Form 3953 (Page 1)

Table H-11. Instructions for Completing DA Form 3953, Purchase Request and Commitment

Note: For RM, DA Form 3953 is a commitment document only. DD Form 1155, the return document sent from the directorate of contracting, is the actual obligation document.

1. **Purpose.** The purpose of DA Form 3953 is to—
 - a. Furnish a document that evidences the first step in procurement and can be scrutinized by all interested officials in advance of actual purchase negotiations.
 - b. Provide a medium on which the FM officer can indicate approval as to the availability of funds and correctness of the accounting classification.
 - c. Provide a means of certifying committed and available funds.
 - d. Provide a worksheet portion on which to record abstract data as required for procurement action.
 - e. Provide space for maintenance of an obligation record in case partial obligations are involved.
2. **Use for Local Procurement.** DA Form 3953 is required when used in connection with local purchase of subsistence supplies as prescribed in AR 30-22; however, it is not mandatory as prerequisite to other procurement actions.
3. **Use as a Purchase Request.** DA Form 3953 executed as a purchase request is completed by the requesting unit to show the following in the appropriate spaces:
 - a. Requisition number and date.
 - b. Explanation of necessity for local procurement.
 - c. Description, quantity, and purpose of items requested.
 - d. Signature and titles of initiating officer, supply officer, and the commander or designee.
 - e. Funds authorized for use and approval of the fund use.
 - f. Required delivery date or period of performance.
4. **Preparation.** The form is prepared by the initiating office in as many copies as necessary to satisfy local administrative needs. As a minimum, the form is prepared in an original and three copies and routed as follows:
 - a. User/Requester provides the estimated cost and forwards the original and two copies to the authorized approving official for approval and certification of availability of funds.
 - b. The authorized approving officer retains one copy and forwards the original and one copy to the contracting office for procurement processing.
5. **Retained copies.** Copies retained in the finance and accounting office are placed in a commitment file pending receipt of the obligating document(s). Upon receipt of the obligation document, the resource manager compares it to the retained copy of the commitment document to determine correctness of the accounting classification and amounts. The retained copy is then attached to the file copy of the obligation document. In the event that more than one obligation document is issued against an individual commitment, the retained commitment, with recorded previous obligations, is attached to the final obligation document.
6. **Completing page 2 of the form.** The reverse side of DA Form 3953 is used to maintain a record of obligations incurred and to determine the unobligated balance of the commitment when partial obligations are involved. It is not to be used when the full amount of the commitment is obligated with a single instrument. When used, annotate the reverse side of the form with the following information:
 - a. Amount committed.
 - b. Date and identifying number of each obligation document.
 - c. Amount of each purchase order, contract, or other obligation document applicable to the commitment.

Appendix H

Table H-11. Instructions for Completing DA Form 3953, Purchase Request and Commitment

- | |
|-----------------------------------------------------------------------------------------------------------------------------------------------------------------------------------------------------------------------------------------------------------------------------------------------------------------------------------------------------------|
| <ul style="list-style-type: none">d. The unobligated balance of the commitment. This balance is derived by subtracting the total of the obligations from the amount of the authorized commitment.e. Any remarks necessary for adequate administrative control of the transactions or activities in connection with the commitment. |
|-----------------------------------------------------------------------------------------------------------------------------------------------------------------------------------------------------------------------------------------------------------------------------------------------------------------------------------------------------------|

DD Form 1155, Order for Supplies or Services

H-35. Figure H-9 shows a sample of completed DD Form 1155. Table H-12 provides detailed instructions on completing the form.

ORDER FOR SUPPLIES OR SERVICES					PAGE 1 OF 1	
1. CONTRACT/PURCH ORDER/AGREEMENT NO. DAFI04-04-M1589		2. DELIVERY ORDER/CALL NO. 0019		3. DATE OF ORDER/CALL (YYYYMMDD) 2004NOV15	4. REQUISITION/PURCH REQUEST NO.	
6. ISSUED BY Director, Purchasing and Contracting (DOC) Fort Jackson, SC 29207		7. ADMINISTERED BY (If other than 6)		8. DELIVERY FOB <input checked="" type="checkbox"/> DESTINATION <input type="checkbox"/> OTHER (See Schedule if other)		
9. CONTRACTOR NAME AND ADDRESS • Allen's Electrical Repair & Services 1479 Two Notch Road Columbia, SC 29227		FACILITY		10. DELIVER TO FOB POINT BY (Date) (YYYYMMDD) 2003SEP07	11. X IF BUSINESS IS <input checked="" type="checkbox"/> SMALL <input type="checkbox"/> SMALL DISADVANTAGED <input type="checkbox"/> WOMEN-OWNED	
14. SHIP TO SS1 Building 10,000 Hampton Parkway Fort Jackson, SC 29207		15. PAYMENT WILL BE MADE BY DFAS-Rome 325 Brooks Road, Rome, NY 13441-4527		13. MAIL INVOICES TO THE ADDRESS IN BLOCK		
16. DELIVERY/ CALL <input checked="" type="checkbox"/> This delivery order/call is issued on another Government agency or in accordance with and subject to terms and conditions of above numbered contract.		PURCHASE <input type="checkbox"/> Reference your		furnish the following on terms specified herein.		
ACCEPTANCE. THE CONTRACTOR HEREBY ACCEPTS THE OFFER REPRESENTED BY THE NUMBERED PURCHASE ORDER AS IT MAY PREVIOUSLY HAVE BEEN OR IS NOW MODIFIED. SUBJECT TO ALL OF THE TERMS AND CONDITIONS SET FORTH, AND AGREES TO PERFORM THE SAME.						
NAME OF CONTRACTOR		SIGNATURE		TYPED NAME AND TITLE	DATE SIGNED (YYYYMMDD)	
If this box is marked, supplier must sign Acceptance and return the following number of copies:						
17. ACCOUNTING AND APPROPRIATION DATA/LOCAL USE 21520200000 315011.00 25GZ ZNON BVGLGBPRC09076 RREC W4RRET S12011						
18. ITEM NO.	19. SCHEDULE OF SUPPLIES/SERVICES		20. QUANTITY ORDERED/ACCEPTED*	21. UNIT	22. UNIT PRICE	23. AMOUNT
1	Repair of HVAC system because of lightning strike(s)		1.0000	job	\$1958.86000	\$1,958.86
*If quantity accepted by the Government is same as quantity ordered, indicate by X. If different, enter actual quantity accepted below quantity ordered and encircle.					24. UNITED STATES OF AMERICA	25. TOTAL \$1,958.86
BY: Arley Handy					CONTRACTING/ORDERING OFFICER	
27a. QUANTITY IN COLUMN 20 HAS BEEN <input type="checkbox"/> INSPECTED <input checked="" type="checkbox"/> RECEIVED <input type="checkbox"/> ACCEPTED, AND CONFORMS TO THE CONTRACT EXCEPT AS NOTED:						
b. SIGNATURE OF AUTHORIZED GOVERNMENT REPRESENTATIVE			c. DATE (YYYYMMDD)	d. PRINTED NAME AND TITLE OF AUTHORIZED GOVERNMENT REPRESENTATIVE		
e. MAILING ADDRESS OF AUTHORIZED GOVERNMENT REPRESENTATIVE			28. SHIP. NO.	29. D.O. VOUCHER NO.	30. INITIALS	
f. TELEPHONE NUMBER		g. E-MAIL ADDRESS	<input checked="" type="checkbox"/> PARTIAL <input type="checkbox"/> FINAL	32. PAID BY	33. AMOUNT VERIFIED CORRECT FOR	
36. I CERTIFY THIS ACCOUNT IS CORRECT AND PROPER FOR PAYMENT.			31. PAYMENT	34. CHECK NUMBER		
a. DATE (YYYYMMDD)	b. SIGNATURE AND TITLE OF CERTIFYING OFFICER		<input type="checkbox"/> COMPLETE <input type="checkbox"/> PARTIAL <input type="checkbox"/> FINAL	35. BILL OF LADING NO.		
37. RECEIVED AT	38. RECEIVED BY (Print)	39. DATE RECEIVED (YYYYMMDD)	40. TOTAL CONTAINERS	41. S/R ACCOUNT NUMBER	42. S/R VOUCHER NO.	

DD FORM 1155, DEC 2001 PREVIOUS EDITION IS OBSOLETE.

Figure H-9. Sample of Completed DD Form 1155

Appendix H

Table H-12. Instructions for Completing DD Form 1155, Order for Supplies or Services	
Item	Instructions
(1)	Block 1. Contract/Purchase Order No.—Enter appropriate Contract Number.
(2)	Block 2. Delivery Order No.—Enter a four-digit (alphabetic and numeric) delivery order number. Reference Defense Federal Acquisition Regulation Supplement (DFARS) 204.7000.
(3)	Block 3. Date of Order—Enter the two position numeric year, three position alphabetic month, and two position numeric day (YYMMMDD) for the date the DD Form 1155 is prepared.
(4)	Block 4. Requisition/Purchase Request No.—Locally generated, as appropriate.
(5)	Block 5. Priority—Enter as appropriate.
(6)	Block 6. Issued By—Enter UIC or DOD activity address code (DODAAC), title of official in charge, code activity name, street address, city, state, zip (include POC, phone, fax #, and e-mail address).
(7)	Block 7. Administered By—Enter appropriate office.
(8)	Block 8. Delivery FOB—Enter destination.
(9)	Block 9. Contractor—Enter the full business name and address of the contractor as listed in the contract.
(10)	Block 10. Deliver to FOB Point By (Date)—Enter date, as negotiated.
(11)	Block 11. Mark if Business is—Mark as appropriate or needed.
(12)	Block 12. Discount Terms—If any, then enter the discount for prompt payment in terms of percentages and corresponding days. Express the percentages in whole numbers and decimals, for example, 3.25% - 10 days; 0.50% - 20 days. (as shown on the contract).
(13)	Block 13. Mail Invoices To—Enter appropriate servicing DFAS address. Same as block 15.
(14)	Block 14. Ship To—Enter ship-to-address (including 6 character UIC/DODAAC), street address building and/or room number), POC, fax# (if available), city, state, zip code.
(15)	Block 15. Payment Will be Made By—Enter the name and address of the activity making payment.
(16)	Block 16. Type of Order—Enter order type, as appropriate.
(17)	Block 17. Accounting and Appropriation Data/Local Use—Enter the accounting classification, the accounting classification reference number(s) and the U.S. dollar amount. Also enter the exchange rate if the order is in local currency. This is a common source of error and payment rejection - ensure you have correct accounting information, including the correct fiscal year.
(18)	Block 18. Item No.—Enter an item number in accordance with the contract or contract line item number (CLIN).

Table H-12. Instructions for Completing DD Form 1155, Order for Supplies or Services	
<i>Item</i>	<i>Instructions</i>
(19)	Block 19. Schedule of Supplies/Services—If the contract line item number (CLIN) is listed in block 18, enter the description here. To authorize partial deliveries, the following statement must be included: Partial shipment and partial payment are authorized. The name and commercial telephone number of the contracting officer's representative (COR)/quality assurance evaluator (QAE)/contracting officer's technical representative (COTR). This is the person responsible for all activities associated with coordinating and implementing delivery, installation, and acceptance. If ordering services to a previously ordered system, reference the original delivery order number. Authorized person(s) to place a repair call under the warranty provisions if other than the designated COR/QAE/COTR. Delivery dates for services: allow for site preparation or other government driven concerns (that is, resource availability, etc.). However, this date should allow for to be determined (TBD) days from when your COMO actually processes your order, so plan accordingly. OCONUS shipments through port of embarkation (POEs) require the following: 1) transportation account code (TAC) or transportation control number (TCN), 2) complete OCONUS ship-to address, and 3) Consignee and Mark for. Mark for: A valid UIC/and address for the final destination. Include a POC and phone number.
(20)	Block 20. Quantity Ordered/Accepted—Enter the total quantity ordered for the line item.
(21)	Block 21. Unit—Enter the unit of measure applicable to the line item.
(22)	Block 22. Unit Price—Enter the unit price (U.S. dollar or local currency) applicable to the line item.
(23)	Block 23. Amount—Enter the extended U.S. dollar or local currency amount (quantity x unit price) for each line item.
(24)	Block 24. Contracting/Ordering Officer—Enter the ordering officer's signature.
(25)	Block 25. Total Amount—Enter the total dollar or local currency amount for all line items on the order. If this is a foreign currency, do not use a dollar sign—insert a local currency (for example, BPS or GM for British Pounds Sterling or Euros). Confirm that sufficient funds are available in the amount funded in block 17.
(26)	Block 26 through 42. These blocks are used in the receiving and payment functions. Procedures for making entries are prescribed by the respective departments; however, blocks 24, 26, 36 must contain different signatures.

DD Form 2406, Miscellaneous Obligation Document (MOD)

H-36. Obligations may be recorded based on estimates. When actual obligation amounts become known, reverse and replace estimated obligations with actual obligations. The estimates and reversals are accomplished using DD Form 2406 (Miscellaneous Obligation Document) (MOD). DD Form 2406 may be used to record obligations for contracts that have been let but for which a hard copy document has not been received. Upon receipt of the hard copy document, reverse out the MOD and record the contract. Figures H-10 and H-11 show a sample of a completed DD Form 2406.

Appendix H

MISCELLANEOUS OBLIGATION DOCUMENT <small>(Use reverse side for continuation of partial payment recorded.)</small>		1. MISCELLANEOUS OBLIGATION DOCUMENT NUMBER MODCJ07RM0122	2. ACCOUNTING CLASSIFICATION 2142020000 315011.00 25GZ QNON BVGLGBPRC09076	3. DATE PREPARED 7 SEP 05			
4. INSTALLATION							
a. Name	MAJ Clyde Arbuckel		b. Title				
b. Address	ACoIS, RM, SSI 10,000 Hampton Parkway Fort Jackson, SC 29207						
5. DESCRIPTION Obligation of funds is required to cover the anticipated cost of electrical repairs to buildings HVAC system due to lightning stikes. Price quote as per Contractor phone call.							
8. AMOUNT \$2,000.00							
9. PARTIAL PAYMENT RECORD							
a. Name of vendor or contractor AI's electric		b. Contract or purchase order number BVGLGBPRC09076.					
DATE	DESCRIPTION	OBLIGATION	ACCRUED EXPENDITURE	ACCOUNTS PAYABLE BALANCE	DISBURSEMENT	BALANCE (X one)	
(1)	(2)	(3)	(4)	(5)	(6)	Unliquidated X	Undelivered (7)

USAPPC V4.00

DD FORM 2406, OCT 85

Figure H-10. Sample of a Completed DD Form 2406 (Front)

INSTALLATION		ACCOUNTING CLASSIFICATION				
MAJ Clyde Arbuckle		21420200000 315011.00.25GZ ONON BVGLGBPRC09076 RREC WARRET S12011				
9. PARTIAL PAYMENT RECORD (Continued)		a. Name of vendor or contractor Al's electric		b. Contract or purchase order number BVGLGBPRC09076.		
DATE (1)	DESCRIPTION (2)	OBLIGATION (3)	ACCRUED EXPENDITURE (4)	ACCOUNTS PAYABLE BALANCE (5)	DISBURSEMENT (6)	BALANCE (X one) Unliquidated Undelivered X (7)

USAPPC V4.00

DD FORM 2406 Reverse, OCT 85

Figure H-11. Sample of a Completed DD Form 2406 (Reverse)

Appendix H

Fiscal Codes and Accounting Classifications

H-37. Figure H-12 shows fiscal code/accounting classifications as identified in DFAS-IN Manual 37-100-04. Table H-13 shows the standard accounting classification data elements. Tables H-14 and H-15 provide two accounting classification examples.

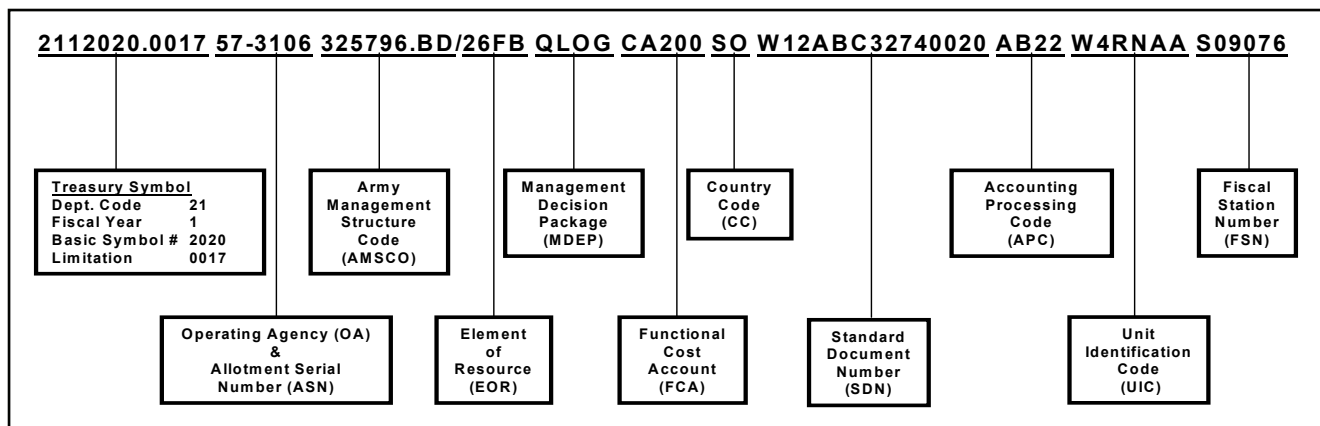

Figure H-12. Fiscal Code/Accounting Classification

Table H-13. Standard Accounting Classification Data Elements		
Data Elements	Governing Directive	Number of Positions
Treasury symbol	DFAS-IN Manual 37-100-FY	11-12
—Department code		2
—Period of availability (FY)		1-2
—Basic symbol		4
—Limitation		4
Program Year	DFAS-IN Manual 37-100-FY	1
Operating Agency	DFAS-IN Manual 37-100-FY	2
Allotment Serial Number See DFAS-IN Manual 37-100-FY for CMA allotment serial numbers.	Assigned by Operating Agency	4
Reimbursement Source Code	DFAS-IN Manual 37-100-FY	3
Army Management Structure Code /Project Account Code	DFAS-IN Manual 37-100-FY	6-11
Element of Resource	DFAS-IN Manual 37-100-FY	4
Management Decision Package/Special Operations Decision Package	DFAS-IN Manual 37-100-FY	4
Functional Cost Account	DFAS-IN Manual 37-100-FY	5
Location Components (Country code)	DFAS-IN Manual 37-100-FY	2
Supplemental Code	DFAS-IN Manual 37-100-FY	1

Table H-13. Standard Accounting Classification Data Elements		
Data Elements	Governing Directive	Number of Positions
Special Data Code	DFAS-IN Manual 37-100-FY	1
Standard Document Number	Table 5-4	14
APC; ACRN, or job order number (JON)	Locally Assigned	2-6
Data Processing Indicator Code		2
Unit Identification Code	DA Force Accounting System-Active Army.	6
Fiscal Station Number	DFAS-IN Manual 37-100-FY	6

Table H-14. Accounting Classification—Example 1		
Example 1: U.S. Army Appropriation - Direct Funds 21 3 2020 57-3106 325796.BD 26FM BN QSUP CA200 GRE12340109003 AB22AB WORNAA S34031		
Data Element	Code	Explanation
Treasury Symbol:		
—Department code	21	Department of Army
—Period of availability (FY)	9	Fiscal Year 99
—Basic symbol	2020	Operations and Maintenance, Army
Operating Agency	57	U.S. Army Training and Doctrine Command (TRADOC)
Allotment Serial Number	3106	Locally Assigned
AMSCO	325796.BD	Base Operations (BASOPS-), TRADOC Director of Logistics (DOL)
Element of Resource	26FM BN	Supplies-Army managed/Defense Working Capital Fund (DWCF) Item
MDEP/special operating decision package (SODEP)	QSUP	Installation Supply Operations
Functional Cost Account	CA200	Commercial Activities—Contract Furnished Supplies
Standard Document Number	GRE12340109003	See Table 5-4
Account Processing Code (APC) and data processing installation (DPI) Code or JON	AB22AB	Locally Assigned

Appendix H

Table H-14. Accounting Classification—Example 1		
Example 1: U.S. Army Appropriation - Direct Funds 21 3 2020 57-3106 325796.BD 26FM BN QSUP CA200 GRE12340109003 AB22AB WORNAA S34031		
<i>Data Element</i>	<i>Code</i>	<i>Explanation</i>
Unit Identification Code (UIC)	WORNAA	Ft. Sill, OK Garrison
Fiscal Station Number	S34031	DFAS-Lawton

Table H-15. Accounting Classification—Example 2		
Example 2: Transfer Appropriation – Executive Office to the President to Department of Defense 97 11 X 8242.GYO1 4 89-1234 ABC123 31FA S91514		
<i>Data Element</i>	<i>Code</i>	<i>Explanation</i>
Treasury Symbol:		
—Department code (receiving)	97	Office, Secretary of Defense
—Department code (issuing)	11	Executive Office of the President
—Period of availability (FY)	X	No Year
—Basic symbol	8242	Foreign Military Sales
—Limitation:		
Country Code	GY	Germany
Transaction Code	O	Alpha "O" (Non-Reimbursable)
Component Code	1	Army
Program Year	4	Fiscal Year 94
Operating Agency	89	U.S. Army Europe
Allotment Serial Number	1234	Locally Assigned
FMS Case and Line Numbers:		
Case	ABC	Assigned by Case Manager
Line	123	Assigned by Case Manager
Element of Resource	31FA	General Equipment, Army/DWCF Managed Item
Fiscal Station Number	S91533	266th FMC

Appendix I

Management Control Program

Leaders and managers perform management control through reviews ranging from the simple to the complex, with the intent of evaluating ongoing mission and operational requirements. When properly implemented, the management control program provides reasonable assurance that the entire management team's daily practices and procedures make sense and properly safeguard entrusted resources.

BACKGROUND

I-1. The Federal Manager's Financial Integrity Act requires each executive agency, including the DOD, to—

- Establish management controls to provide reasonable assurance that: obligations and costs are in compliance with applicable laws; funds, property, and other assets are safeguarded against waste, loss, unauthorized use, or misappropriation; revenues and expenditures are properly recorded and accounted for; and programs are efficiently and effectively carried out according to the applicable law and management policy.
- Report annually to the President and Congress on whether these management controls comply with requirements of the Integrity Act, to include: (1) a report identifying any material weaknesses in these management controls, along with plans for their correction, and (2) a report on whether accounting systems comply with the principles, standards, and related requirements prescribed by the Comptroller General, to include deficiencies and plans for their correction.

REGULATORY GUIDANCE

I-2. For the Army, AR 11-2 implements The Federal Managers' Financial Integrity Act. The management control process defined by AR 11-2 is based on AIMD-00-21.3.1, which is published by the Comptroller General of the United States (U.S. General Accounting Office). It describes twelve standards against which management control systems are evaluated. These standards, which are listed in Table I-1, are defined in the following paragraphs, and described in detail in Appendix B of AR 11-2. Ensuring management controls in each organization conform to these Comptroller General standards is a basic responsibility of every financial manager.

Table I-1. Summary of Comptroller General Standards for Management Controls	
General Standards	Reasonable Assurance
	Supportive Attitude
	Competent personnel.
	Control objectives.
	Control techniques.
Specific Standards	Documentation.
	Recording transactions.
	Executing transactions.
	Separation of duties.

Appendix I

Table I-1. Summary of Comptroller General Standards for Management Controls	
	Supervision.
	Access to and accountability for resources.
	Prompt resolution of audit findings.

I-3. The terms used in Table I-1 are defined as follows:

- *Reasonable Assurance*—Management controls are used to provide reasonable assurance that the objectives of the systems will be accomplished. The cost of the control should not exceed the benefit. It equates to a satisfactory level of confidence that the control will prevent a loss.
- *Supportive Attitude*—Leaders, Soldiers, and employees are to maintain and demonstrate a positive and supportive attitude toward the management control program at all times. Leaders take steps to promote the effectiveness of management controls and make them a high priority.
- *Competent Personnel*—Leaders, Soldiers, and employees are to have personal and professional integrity and maintain a level of competence to accomplish their duties. All must understand the importance of developing and maintaining good management controls.
- *Control Objectives*—Objectives are identified or developed for each activity and are logical, applicable, and reasonably complete. Control objectives are tailored to fit specific operations.
- *Control Techniques*—Techniques are efficient and effective to accomplish management control objectives. Policies, procedures, or arrangements fulfilling the intended purpose are examples of techniques that ensure effectiveness.
- *Documentation*—All management control systems, transactions, or events are clearly documented and available for examination. Written evidence of techniques, standard procedures, policy, or evaluation is mandatory.
- *Recording Transactions*—Transactions and other significant events are promptly recorded and properly classified.
- *Executing Transactions*—Transactions and other significant events are authorized and executed only by persons acting within the scope of their authority. A common method used is a published Command Supply Discipline Program with the G4 or IG conducting inspections.
- *Separation of Duties*—Key duties and responsibilities in authorizing, processing, recording, and reviewing transactions are separated among individuals. To reduce risk, no one person can control all aspects of a transaction or event.
- *Supervision*—Qualified and continuous supervision is provided to ensure management control techniques are achieved.
- *Access to and Accountability for Resources*—Access to and accountability of resources and records is limited to authorized personnel only.
- *Prompt Resolution of Audit Findings*—Managers are to evaluate findings promptly, review recommendations, determine proper actions, and complete corrective actions in a timely manner.

EXECUTION OF THE MANAGEMENT CONTROL PROGRAM (MCP)

CORE ACTIONS

I-4. Effective execution of the management control program involves a range of core actions outlined in AR 11-2 or directed by the commander. The financial manager assists by publishing these actions to meet regulatory and reporting requirements. These core actions are—

- Define functions, controls, and measures for each activity.
- Establish a MCP in accordance with DA and ASCC five year assessment plans.
- Conduct management control evaluations in accordance with the MCP.
- Identify, report, and correct material weaknesses.

- Update material weakness action plans at mid-year and end-of-year.
- Prepare the unit annual assurance statement.
- Provide management control training.
- Document management control responsibilities of key management officials in their support forms/performance plans (required for O6/GM15/functional managers and above).
- Link the management control process with the review and analysis program.

RESPONSIBILITIES

I-5. Assessable unit manager (AUM), O6/GM15 or above, will—

- Provide the leadership and support needed to ensure management controls are in place and operating effectively.
- Outline personal insights and philosophies concerning the management control process.
- Ensure managers are trained and understand their management control responsibilities.
- Ensure that an MCP is established and maintained to describe how key management controls within the unit are evaluated over a five year period, in accordance with DA and ASCC five year assessment plans.
- Ensure management control evaluations are conducted according to the management control program and the requirements of AR 11-2.
- Ensure required documentation on each completed management control evaluation is retained, subject to audit/inspection.
- Certify the results of required management control evaluations (DA Form 11-2-R [Management Control Evaluation Certification Statement]).
- Report through the chain of command any material weaknesses in management controls, establish and implement plans to correct those material weaknesses, and track progress in executing those plans until the material weakness is corrected.
- Sign an annual statement of assurance accurately describing the status of management controls, to include any material weaknesses, and submit this statement to higher headquarters.
- Negotiate an explicit statement of responsibility for management controls in the performance agreements (DA Form 67-9-1 (Officer Evaluation Report Support Form) or DA Form 7222-1 (Senior System Civilian Evaluation Report Support Form)) of division, program, and office chiefs responsible for the execution and oversight of effective management controls.

I-6. The proponent for the management control program, as the management control administrator (MCA), will—

- Serve as the unit “subject matter expert” on the management control program, and as such, develop a comprehensive understanding of management control program policies, procedures, and required actions as outlined in AR 11-2 and other applicable sources.
- Advise the AUM on the implementation and status of the organization’s management control process.
- Keep the unit, office, and program chiefs, and associated commanders, managers, and points of contact informed on management control matters.
- Identify the organization’s requirements for management control training and provide that training.
- In coordination with the higher headquarters, develop, execute, and maintain an MCP for the unit.
- Coordinate the preparation of the annual assurance statement on management controls.
- Coordinate the development of statements of functions, controls, and measures for each unit, staff, office, or program within the unit.

Appendix I

- Ensure material weaknesses for which the organization is responsible are tracked until corrected, to include preparing updated action plans for all material weaknesses at mid-year and end-of-year (in the annual assurance statement).
- Retain all required documentation in support of annual statements, management control evaluations, and the correction of material weaknesses (AR 11-2, paragraph 1-16).

I-7. Subordinate commanders, staff, and units will—

- Provide the leadership and support needed to ensure management controls are in place and operating effectively.
- Designate activity management control process points of contact.
- Ensure applicable subordinate managers and personnel are trained and understand their management control responsibilities.
- Develop a statement of functions, controls, and measures for their activity, and update it on an annual basis.
- Where feasible, link established controls and measures to the review and analysis program.
- Execute and document the evaluation of key management controls (as identified in the master MCP) using either management control evaluation checklists or an existing management review process.
- Report through the MCA to the commander, any material weaknesses in management controls, establish and implement plans to correct those material weaknesses, and track progress in executing those plans until the material weakness is corrected.
- Sign an annual statement of assurance accurately describing the status of management controls within their area of responsibility, to include any material weaknesses, and submit this statement to the MCA.
- Negotiate an explicit statement of responsibility for management controls in the performance agreements (DA Form 67-9-1 or DA Form 7222-1) of key subordinates responsible for the execution and oversight of effective management controls.

I-8. All assigned personnel, as stewards of taxpayer financed resources, will, within their limits of authority and responsibility—

- Display a high level of commitment towards mission accomplishment and the safeguard of resources entrusted to their care.
- Maintain and demonstrate a positive and supportive attitude towards management control.
- Practice personal and professional integrity and maintain a level of competence that allows them to accomplish assigned duties.
- Establish, maintain, and practice effective management controls and assess areas of risk.
- Identify and correct weaknesses in those controls, and promptly report the absence or ineffectiveness of controls judged as material weaknesses.
- Keep their superiors informed on all management control related issues.

Appendix J

Destruction of Currency

J-1. In a situation in which it appears an FM unit's position may be overrun, currency is evacuated. If evacuation is not possible and capture of funds seems inevitable, currency must be disposed of to prevent capture and use by the enemy (see DOD 7000.14-R, Volume 5, Chapter 18).

J-2. Destroy paper currency by burning it to ashes. Depending on METT-TC, prepare an itemized destruction schedule listing the type, serial number, and denomination of each bill. If time does not permit preparation of an itemized destruction certificate, an abbreviated destruction schedule listing the amount of bills by denomination will be prepared. Have the burning witnessed by three disinterested U.S. officers, who then sign the destruction schedule.

J-3. Coin will not be included in the currency destruction schedule because the U.S. Treasury has no authority to reimburse the Army for coins destroyed or otherwise disposed of. Coinage is disposed of by scattering it in deep bodies of water or secretly burying it. Prepare a disposal schedule and have it signed by two disinterested U.S. officers who witness the disposal. A record of the location is made, classified Secret, and sent to the FMC.

J-4. Paper currency and other negotiable instruments contaminated as a result of a chemical, biological, radiological, and nuclear (CBRN) attack or unfit for circulation (e.g., badly burned, blood-soaked, or saturated by body fluids) are destroyed by burning. Prepare an itemized destruction schedule and have it signed by three disinterested U.S. officers who witness the burning, as explained above. When possible, decontaminate contaminated coinage using standard decontamination methods for metal equipment, and put the coins back into use. Copy contaminated vouchers when practical. Certify the copies as true and correct, and burn the contaminated originals. Prepare a memorandum for record (MFR) with a list of document/serial numbers, explaining why the originals were replaced and attach the copies of the originals. Keep in mind that burning may cause a downwind hazard.

J-5. If currency in the custody of an FM element is suddenly destroyed (for example, by explosion, fire, or sinking of a vessel), the senior FM officer must make a statement explaining the circumstances and give as detailed a listing as possible of the amounts of currency destroyed. If the accountable officer does not survive, his accountability will be reconstructed by any FM personnel left in the area, in coordination with DFAS.

J-6. FM commanders will not drop accountability for currency destroyed or concealed. They will continue to maintain accountability until reimbursement is received, concealed currency is recovered, or relief is granted.

J-7. Handle contaminated automatic data processing equipment and supplies IAW unit SOP.

This page intentionally left blank.

Appendix K

Template SOP—Cashing Personal Checks During Deployments

The following is suggested text for unit standing operating procedures (SOP) on the cashing of personal checks during deployments.

Note: Use the paper check conversion (PCC) system if available. If the PCC is used, modify the procedures below as applicable.

Standing Operating Procedures for Cashing Personal Checks During Deployments

FM units will normally cash checks for Soldiers and other authorized individuals in limited dollar amounts during deployments. All paying agents, cashiers, and cash control officers (CCOs) must read, understand, and possess a file copy of any applicable disbursing and cashier policy messages for the theater of operations. The following are general procedures for the cashier to follow when cashing personal checks:

1. Ask the customer for his/her identification (ID) card, verifying he/she is authorized to cash a check (as applicable and in accordance with local/theater guidance).
2. Check the individual's ID card against any bad check lists (if used). Make sure to use the information on the ID card, not the information printed or written on the check. If the customer is on a bad check list, do not cash the check. Inform the customer that you cannot cash the check due to their status on a bad check list. If the customer is not on a bad check list, continue with the transaction.
3. Ensure the check is not a two party check (a check written from one person to another). These checks cannot be cashed. Personal checks must be written by the customer, on the customer's own account, payable to the order of the financial management unit or the U.S. Treasury.
4. Determine if the check is a regular personal check (with a preprinted name) or a starter/counter check. Starter/counter checks will not have any preprinted information (name, address, etc.) in the top left portion of the check. Starter/counter checks will be cashed only IAW established theater policy (as applicable).
5. If a check cashing tracking system is in use, verify the person has not cashed any checks previously for the week or month, as policy dictates. If the individual has already cashed a check during the period, make sure the total is not more than the limit for the period. Do not cash any checks placing the customer over the period limit unless approved by a designated authority (normally within the FM unit). Have the approver provide a signed memo/note of explanation or have him/her initial the check. As applicable, ask the customer to fill out the information on the trackable limit sheet and ensure he/she fills it out correctly.
6. If the customer is a civilian, verify a DD Form 2761 (Personal Check Cashing Agreement) is on file. If not, have the customer fill out a DD Form 2761 before cashing any checks.
7. Ensure the following information is clearly written on all negotiable instruments:
 - a. Printed name.
 - b. Rank/GS level/etc.

Appendix K

- c. Social Security number (verify this number with the ID card).
 - d. Current unit of assignment.
 - e. Complete mailing address.
 - f. Unit phone number.
 - g. Branch of Service (if not Army).
 - h. Expiration term of service (ETS) (verified from ID Card) (as applicable). Do not cash any checks for personnel whose term of service will expire within the timeframes established in applicable theater guidance.
 - i. Reserve or National Guard (as applicable).
8. Stamp or print the word "cashier" in the top right part of the check and place your initials next to the stamped or printed word.
 9. If not already completed, stamp or print your FM unit designation in the "pay to the order of" line.
 10. Stamp or print the following in any free space in the bottom portion of the check: "I consent to immediate collection from my pay the amount of this check plus bank charges if this check is dishonored_____". Give the check back to the customer and have him or her initial this statement in the blank space at the end of the statement. Ensure the customer initials the statement.
 11. Stamp or print the following on the back of the check- FOR CREDIT TO TREASURER OF U.S., (name of account holder), DSSN XXXX, CITY, STATE, ZIP.
 12. Ensure the customer legibly completes the applicable portions of DD Form 2664 (Currency Exchange Record) and places their Social Security Number on the form.
 13. Once all of the above actions and items are properly completed, disburse the amount of the check in U.S. dollars and/or local currency (based on the applicable exchange rate) and return the customer's ID card. Make sure to count the money three times before the customer takes possession of the funds.

Appendix L

Template SOP—Foreign Currency Conversions and Reconversions

The following is suggested text for unit standing operating procedures (SOP) for converting and reconverting U.S. and foreign currency.

Standing Operating Procedures for Foreign Currency Conversions and Reconversions

In deployed environments, FM units normally conduct conversion and reconversion transactions with and between U.S. and foreign currency. Conversions are transactions changing U.S. dollars into a foreign currency at a stated exchange rate. Reconversions are transactions changing a foreign currency into U.S. dollars at a stated exchange rate. All paying agents, cashiers, and cash control officers (CCOs) must read, understand, and possess a file copy of any applicable disbursing and cashier policy messages for their theater of operations. General procedures for conducting conversion and reconversion transactions are as follows:

1. Prior to conducting any conversion/reconversion transactions, ensure you have the day's official conversion and reconversion exchange rates for your theater/area of operation. Ensure you know the correct procedures for obtaining the "official" daily rate for your area of operations.
2. All exchanges are usually done in even dollar/foreign currency increments (this speeds customer service operations and mitigates the possibility of losses of funds). Exceptions to this procedure should be granted only by a designated official in the FM unit.

Note: One technique to establish conversion and reconversion increments is to develop and print a spreadsheet containing conversion/ reconversion amounts based on the chosen increment of exchange and that day's exchange rates. This spreadsheet may be posted in customer service areas and used by cashiers to aid in conducting conversion and reconversion transactions.

3. When a customer arrives and asks to conduct a conversion/reconversion transaction, first ask the customer for his/her ID card, verifying he/she is authorized to conduct the transaction (as applicable, in accordance with local/theater guidance).
4. Once the customer's status is verified, count and verify (in front of the customer) the total of all currencies he/she has given you for the transaction. Confirm this amount agrees with what the customer counted and it is the amount the customer wants to exchange. Always screen/spot-check money from customers for possible counterfeits.
5. For conversions (the customer gives you U.S. dollars and wants foreign currency), ensure the U.S. dollar amount is an even increment (as applicable). Take the U.S. dollar total and multiply it by the official foreign currency conversion rate for that day. The result is the amount of foreign currency you must disburse to the customer. Disburse the payment, ensuring it is counted three times before the customer takes possession of the funds. Fill out the applicable portions of DD Form 2664 (Currency Exchange Record) and return the customer's ID card.
6. For reconversions (the customer gives you foreign currency and wants U.S. dollars), ensure the foreign currency amount is an even increment (as applicable). Take the foreign currency total and divide it by the official foreign currency reconversion rate for that day. The result is the amount of U.S. dollars you must disburse to the customer. Disburse the payment, ensuring it is counted three times

Appendix L

before the customer takes possession of the funds. Fill out the applicable portions of DD Form 2664 and return the customer's ID card.

7. Reconversions are normally conducted only for customers who are about to leave the area of operations/redeploy. Soldiers and other authorized customers are strongly encouraged to spend their foreign currency before departing, rather than reconverting it (at a normally higher—and therefore disadvantageous—rate). Reconversion transactions should normally not exceed an amount equal to two weeks of the customer's pay and allowances (exceptions to this amount should be approved by a designated FM unit official).

Note: All reconversions will be done IAW DOD 7000.14-R, Volume 5, paragraph 120304E.

Appendix M

Template SOP—Casual Payments Using DD Form 1351-6

The following is suggested text for unit standing operating procedures (SOP) for making casual payments during deployments.

Standing Operating Procedures for Making Casual Payments using DD Form 1351-6

In deployed environments, FM units normally make casual payments (CPs) in cash to Soldiers. These payments are normally authorized when Soldiers do not have access to ATMs or checks available. Casual payments are intended to provide Soldiers with small amounts of money, therefore, strict limits on the amount and frequency of casual payments must be observed. Casual payments may be paid only to U.S. military personnel. United States civilian employees and other personnel, and non-U.S. personnel are not authorized casual payments. Casual payments should not be treated as “no-interest” loans. Casual payments are input immediately into DJMS and collected from the Soldier’s next available paycheck. All paying agents, cashiers, and cash control officers (CCOs) must read, understand, and possess a file copy of any applicable disbursing and cashier policy messages for the theater of operations (especially those regarding casual pay limits and frequency). General procedures for making casual payments are as follows:

1. Before making any casual payments, establish DD Form 1351-6 (Multiple Travel Payments List) by the following categories (labeling the top of each form as stated below):
 - a. Army Active Duty Enlisted.
 - b. Army Active Duty Officers (warrant and commissioned).
 - c. Army Reserve Enlisted.
 - d. Army Reserve Officers (warrant and commissioned).
 - e. Other branches of Service (Air Force, Navy, Marine, and Coast Guard), also separated by Active Duty/Reserve and by Officer/Enlisted categories (individual forms for each Service, category of Service Member (officer or enlisted), and status of Service Member (active or reserve)).
2. When a Soldier or other Service Member arrives and asks for a casual payment, first ask the Soldier/Service Member for his/her ID card, verifying he/she is authorized to conduct the transaction (as applicable, in accordance with local/theater guidance).
3. If a casual payment tracking system is in use, verify whether the Soldier/Service Member has previously received a casual payment. Ensure the Soldier/Service Member is not over the limit authorized for the applicable time period in effect.
4. Obtain the correct DD 1351-6 for the Service Member (as stated above). Ensure the administrative data on the form is accurate. Voucher numbers will normally be annotated once the cashier clears his/her business with their funding activity.
5. Write in the correct category type (for example, Army Active Duty Enlisted, Naval Reserve Officer, etc.), unit, Social Security number, name of the Soldier/Service Member receiving the payment, and the amount of the payment on the DD 1351-6 where appropriate. Ensure all information is accurate and legible. (**Note:** Leave block 5e, “TRAVEL ORDER OR OTHER AUTHORITY,” blank. While this form can also be used for travel payments, travel payments should not be made on a form containing casual payments.)
6. Ask the Soldier/Service Member to sign in block 5g to acknowledge receipt of the cash payment, and pay the Soldier/Service Member in U.S. dollars, as appropriate. Ensure the payment is counted

Appendix M

three times before the Soldier/Service Member takes possession of the funds. If the Soldier/Service Member requests foreign currency, conduct a separate conversion transaction. Once all transactions are concluded, return the Soldier's/Service Member's ID card.

7. Input the Soldier's/Service Member's name, Social Security number, and payment amount in the casual payment tracking system (as applicable).

8. At the end of your cashier duties, total the amounts on each DD Form 1351-6.

9. Insert the name and title, and obtain the signature, of the applicable certifying officer (from your FM unit) in blocks 7a and 7b respectively, and submit the completed form(s) with your other cashier business. The FM detachment or company disbursing section should complete the remainder of the form(s) (including the appropriate accounting classification(s)).

Appendix N

Template SOP—Precertified Payment Processing Using SF 1034

This Appendix provides instructions for processing payment for precertified vouchers (vouchers completed and certified by an office or entity external to the FM unit) using SF 1034.

Instructions for Processing Precertified Vouchers using SF 1034

1. Examples of this type of voucher are an authorization for civilian clothing allowance and a solatium payment.
2. Ask the customer for his/her ID card and the voucher (an original and four copies).
3. Ensure that the payee name and Social Security number on the SF 1034 match the ID card.
4. Ensure that the totals are multiplied and/or added correctly.
5. Verify the accounting classification block is correct (that it contains a valid, current-year appropriation).
6. Ensure the signature and name in the “Pursuant to authority vested in me, I certify this voucher is correct and proper for payment” block matches the name and signature on the certifying officer signature card(s) maintained in your unit for this type of payment. (**Note:** The date on the certifying officer card should not be more than one year old.)
7. Write in the “cash” block (in the “paid by” section at the bottom of the voucher) the amount paid. Annotate the date paid in the “date” block. Ask the customer to write his/her full name and signature in the “payee” block.
8. Pay the customer in U.S. dollars or foreign currency as appropriate (ensuring you count the payment three times before the customer takes possession of the funds).
9. Return the customer’s ID card, along with a copy of all completed documentation (ensuring you retain the original voucher).

This page intentionally left blank.

Appendix O

Template SOP—Solatium Payments

This Appendix provides instructions for making solatium payments. A solatium payment is monetary compensation given to indigenous personnel to alleviate grief, suffering, and anxiety resulting from injuries and property or personal loss due directly or indirectly to U.S. Government/military actions. A solatium payment is nominal in amount and is not an admission of liability by the U.S. Government. Payment of solatia is made in accordance with local customs, particularly in the Far East and Middle East. A solatium payment requires the presence of a payment witness. Following the sample instructions for making a solatium payment, Figure O-1 shows a sample witness statement documenting the witnessing of the solatium payment.

The supporting FM unit is responsible for the disbursing and accounting of all solatium payments.

PAYMENTS

O-1. An offering of solatia seeks to convey personal feelings of sympathy or condolence toward the victim or the victim's family. Such feelings do not necessarily derive from legal responsibility; the payment is intended to express the remorse of the person involved in an incident. Such payments usually are made immediately, in nominal amounts which vary according to both the responsible party's ability to pay, and to local custom. In certain countries, the payment is not always made in money. A custom need not be of ancient origin or common to an entire country to be a basis for payment of solatia.

O-2. Solatium payments are made from a unit's operation and maintenance funds pursuant to directives established by the appropriate commander for the country concerned; they are not disbursed from claims funds. Although solatia programs are usually administered under the supervision of a command claims service, they are essentially a theater command function whose propriety is based on a local finding that solatia payments are consistent with prevailing customs. Use SF 1034 (Public Voucher for Purchases and Services Other Than Personal) for these payments.

O-3. A solatium payment may not be used in lieu of an advance payment, if such is warranted and authorized under 10 USC 2736. Normally, a nominal solatium payment is not offset from a subsequent award based on statutory liability. However, when a solatium payment amount is high in relation to the claim's value, the adjudicating authority may consider this fact in determining the claim award.

Instructions for Making a Solatium Payment

1. The local commander determines the need for a solatium payment (with the advice and counsel of his/her servicing Staff Judge Advocate (SJA)).
2. The servicing SJA completes and precertifies an SF 1034 for the payment.
3. A representative from the servicing SJA brings the precertified voucher (original and four copies) to the FM unit for verification and to make arrangements for the payment. The SJA must also coordinate for the presence of a payment witness (normally an SFC or the equivalent civilian rank, or higher; this individual must also be a disinterested individual (not assigned to the SJA or FM unit)) when the actual payment is made.
4. Once the FM unit verifies the SF 1034, it agrees with the SJA on the method and mode of payment. Payments may be effected through use of a paying agent or by direct disbursement from a member of the FM unit (such as a cashier). Normally, a solatium payment is made at the location of the individual(s) receiving payment; this necessitates coordination for transportation and proper security (these are normally the responsibility of the unit initiating the payment).
5. Once the payee, SJA, witness, and paying agent/cashier are present at one location, the payment may be disbursed. This should be done as follows:
 - a. Verify the identity of the witness via his/her ID card.
 - b. Verify the identity of the individual(s) receiving payment (through the best means possible, such as a local national ID card, work permit, passport, etc).
 - c. Ask the witness to complete a "witness memorandum".
 - d. Ask the payee to sign the SF 1034 in the appropriate block.
 - e. Pay the individual(s) in U.S. dollars or foreign currency, as appropriate, ensuring you (the paying agent or cashier) count the payment three times before the payee takes possession of the funds.
 - f. Return the payee's identity papers, along with a copy of all completed documentation (ensuring retention of the original voucher and other documentation).
6. Clear the paying agent or cashier, ensuring he/she submits the original payment voucher and witness statement.

<p>DEPARTMENT OF THE ARMY 8th FM CO UNIT 23731 APO AE 09034</p>	
AEUFC-FBB-DISB	Date: 20 Aug 1998
MEMORANDUM FOR RECORD	
SUBJECT: Solatium Payment Witness Statement	
I, CPT John Doe, the undersigned, have witnessed a payment in the amount of \$1100.00 U.S. dollars, made by SSG Jane Doe, Paying Agent, to Juan Doe, a local national of Kosovo. This payment was for the destruction of Juan Doe's barn by an M1A1 Abrams tank on 01 July 1998.	
Payment was made on 20 Aug 1998.	
WITNESS: CPT John Doe SFC Petty Door (SJA Representative)	
POC: SSG Jane Doe	

Figure O-1. Sample Solatium Payment Witness Statement

This page intentionally left blank.

Appendix P

Template SOP—Rewards Programs

This Appendix provides instructions for making payments under the auspices of a “weapons for cash” rewards program. Rewards programs are initiated as appropriate to encourage certain types of behavior amongst indigenous personnel. For example, rewards programs can be used to encourage the turn-in of weapons or the submission of intelligence. Payments under the “weapons for cash” rewards program are processed using DA Form 4137 (Evidence/Property Custody Document) or a locally developed form, as appropriate. Figures P-1 and P-2 show a sample DA Form 4137.

Instructions for Making Payments Under the Auspices of a “Weapons for Cash” Rewards Program

Note: The procedures for other rewards programs vary, depending on the type and scope of the program.

1. The FM unit should designate a team for each “weapons for cash” payment mission. At a minimum, this team should consist of an officer in charge/NCOIC and one cashier. Other cashiers may be added as appropriate. (Paying agents may also be funded for these types of missions.) Local military police or combat arms units (normally from the unit responsible for operating the turn-in/payment site) should provide security for the team/paying agent(s) and the payment location.
2. For safety and security reasons, the cashier(s) or paying agent(s) should be located approximately 50 to 100 meters from the weapon turn-in point.
3. The unit operating the turn-in site accepts the weapons (engraving serial numbers if they are not present) and completes the necessary receipt/payment paperwork (DA Form 4137 or locally developed forms, as appropriate, in the appropriate number of copies). See figures P-1 and P-2 for a completed sample of DA Form 4137.
4. Once the payment receipt is complete, a member of the unit operating the turn-in site escorts the receipt and the individual turning in the weapon(s). Payments will not be made to unescorted indigenous personnel or local nationals.
5. The cashier or paying agent must verify the DA Form 4137 or receipt/payment paperwork before making payment. At a minimum, all receipts/payment forms should include the following:
 - a. Local national’s (LN’s) name.
 - b. LN’s ID # (as applicable).
 - c. LN’s complete address.
 - d. Basic type/description of the weapon.
 - e. Serial number of the weapon.
 - f. Printed name and rank, and signature of the individual receiving the weapon.
 - g. Printed name and rank, and signature of the LN. Verify the identity of the LN and compare identification documentation with the name and signature placed on the DA Form 4137, if possible. (Obtaining the signature of the LN should be the last step taken before the disbursement of cash.)
6. Pay the LN in U.S. dollars or foreign currency, as appropriate (ensuring you count the payment three times before the payee takes possession of the funds).

Appendix P

7. Return the LN's identity papers (as applicable), along with a copy of the DA Form 4137 (ensuring you, the paying agent, retain the original).
8. Give a copy of the DA Form 4137 to the escort (the escort should turn in this form to his/her unit, as an internal control check).
9. Clear the cashier(s) and/or paying agent(s) and complete an SF 1034 summary voucher (ensuring it contains the correct appropriation for the program in question). The DA Forms 4137 must be attached for substantiation.

EVIDENCE/PROPERTY CUSTODY DOCUMENT			MPR/CID SEQUENCE NUMBER 12345	
For use of this form see AR 190-45 and AR 195-5; the proponent agency is US Army Criminal Investigation Command			CRD REPORT/CID ROI NUMBER	
RECEIVING ACTIVITY U.S. Army		LOCATION Where obtained		
NAME, GRADE AND TITLE OF PERSON FROM WHOM RECEIVED <input checked="" type="checkbox"/> OWNER Juan Doe I.D. # 11112 <input type="checkbox"/> OTHER		ADDRESS (Include Zip Code) 1313 Mockingbird Lane El Bario, Kosovo 22333		
LOCATION FROM WHERE OBTAINED 95th MP A Company, Task Force Alpha Camp Bonsteel, APO AE 09034		REASON OBTAINED Exchange for cash Weapons for cash program	TIME/DATE OBTAINED 20 Aug 2002	
ITEM NO.	QUANTITY	DESCRIPTION OF ARTICLES <i>(Include model, serial number, condition and unusual marks or scratches)</i>		
001	001	Pistol, Single shot .38 Caliber, Serial number 11111		
---	-----	-----Nothing Follows-----		
CHAIN OF CUSTODY				
ITEM NO.	DATE	RELEASED BY	RECEIVED BY	PURPOSE OF CHANGE OF CUSTODY
001	20 Aug 02	SIGNATURE Juan Doe	SIGNATURE Dec M. Police	Turn in for Weapons for Cash program
		NAME, GRADE OR TITLE Juan, Doe, Local National	NAME, GRADE OR TITLE SSG, USA, Weapons/Cash NCOIC	
		SIGNATURE	SIGNATURE	
		NAME, GRADE OR TITLE	NAME, GRADE OR TITLE	
		SIGNATURE	SIGNATURE	
		NAME, GRADE OR TITLE	NAME, GRADE OR TITLE	
		SIGNATURE	SIGNATURE	
		NAME, GRADE OR TITLE	NAME, GRADE OR TITLE	

DA FORM 4137, 1 JUL 76 Replaces DA FORM 4137, 1 Aug 74 and DA FORM 4137-R Privacy Act Statement 28 Sep 75 Which are Obsolete USAPPC V1.00

LOCATION _____ DOCUMENT NUMBER _____

Figure P-1. Sample of Completed DA Form 4137 (Front)

Appendix P

ITEM NO.	DATE	CHAIN OF CUSTODY (Continued)		
		RELEASED BY	RECEIVED BY	PURPOSE OF CHANGE OF CUSTODY
		SIGNATURE	SIGNATURE	
		NAME, GRADE OR TITLE	NAME, GRADE OR TITLE	
		SIGNATURE	SIGNATURE	
		NAME, GRADE OR TITLE	NAME, GRADE OR TITLE	
		SIGNATURE	SIGNATURE	
		NAME, GRADE OR TITLE	NAME, GRADE OR TITLE	
		SIGNATURE	SIGNATURE	
		NAME, GRADE OR TITLE	NAME, GRADE OR TITLE	
		SIGNATURE	SIGNATURE	
		NAME, GRADE OR TITLE	NAME, GRADE OR TITLE	
		SIGNATURE	SIGNATURE	
		NAME, GRADE OR TITLE	NAME, GRADE OR TITLE	
		SIGNATURE	SIGNATURE	
		NAME, GRADE OR TITLE	NAME, GRADE OR TITLE	
		SIGNATURE	SIGNATURE	
		NAME, GRADE OR TITLE	NAME, GRADE OR TITLE	
FINAL DISPOSAL ACTION				
RELEASE TO OWNER OR OTHER (Name/Unit) _____				
DESTROY _____				
OTHER (Specify) _____				
FINAL DISPOSAL AUTHORITY				
ITEM(S) _____ ON THIS DOCUMENT, PERTAINING TO THE INVESTIGATION INVOLVING _____ (Grade)				
_____ (Name) _____ (Organization) (IS) (ARE) NO LONGER				
REQUIRED AS EVIDENCE AND MAY BE DISPOSED OF AS INDICATED ABOVE. (If article(s) must be retained, do not sign, but explain in separate correspondence.)				
_____ (Typed/Printed Name, Grade, Title) _____ (Signature) _____ (Date)				
WITNESS TO DESTRUCTION OF EVIDENCE				
THE ARTICLE(S) LISTED AT ITEM NUMBER(S) _____ (WAS) (WERE) DESTROYED BY THE EVIDENCE CUSTODIAN, IN MY PRESENCE, ON THE DATE INDICATED ABOVE.				
_____ (Typed/Printed Name, Organization) _____ (Signature)				

USAPPC V1.00

Figure P-2. Sample of Completed DA Form 4137 (Back)

Appendix Q

Template SOP—Travel (Temporary Duty) Payments Using DD Form 1351-6

This Appendix gives instructions for making travel (temporary duty (TDY)) payments using DD Form 1351-6 (Multiple Travel Payment Lists).

General Procedures for Making Travel (TDY) Payments Using DD Form 1351-6

Note: Only an authorized FM unit individual may initiate travel payments.

The following are general procedures for making travel (TDY) payments:

1. Research any prior travel advances made (in the applicable travel and/or accounting processing system) and account for these amounts, as required.
2. Once the entitlement to payment has been established, ensure you have a copy of the applicable travel orders (TCS or TDY) for the requested payment(s). Complete separate DD Forms 1351-6 for each unique set of travel orders (individuals on a “block” or “group” travel order can and should be processed on the same DD Form 1351-6). Each unique DD Form 1351-6 must contain only one appropriation. (**Note:** There are no restrictions on mixing officer, enlisted, and civilian personnel, and individuals from different Services on a single DD Form 1351-6, as long as all individuals in question appear on the same travel order.) Once the required DD Form(s) 1351-6 are fully completed (to include the proper appropriation and payment amount(s)), payments may be made.
3. Ask the customer for his/her ID card, ensuring each individual’s personal information is accurate on the payment voucher. Pen and ink changes to the payee information may be made if necessary (both the payee and the individual making payment should initial any changes).
4. Ask the customer to sign in block 5g to acknowledge receipt of the cash payment, and pay the customer in U.S. dollars, as appropriate (ensure you count the payment three times before the customer takes possession of the funds). If the customer requests foreign currency, conduct a separate conversion transaction. Once all transactions are concluded, return the customer’s ID card.
5. Total the amounts on each DD Form 1351-6 after all payments have been made (ensure a copy of the applicable travel order is attached to the voucher). Insert the name and title, and obtain the signature, of the applicable certifying officer from your FM unit in blocks 7a and 7b respectively, and submit the completed form(s) with your other cashier business. The FM unit disbursing section will place the appropriate voucher number on the form.
6. A copy of the voucher should be provided to the FM unit travel section for automated travel system processing.

This page intentionally left blank.

Appendix R

Template SOP—Completing DD Form 1081

This Appendix gives instructions for completing DD Form 1081 (Statement of Agent Officer's Account). This form is used to record advances and returns of funds, vouchers, and other negotiable instruments between paying agents, cashiers, and FM unit disbursing personnel (referred to in the remainder of this Appendix as disbursing officials or disbursing officers (Dos)).

Instructions for Completing DD Form 1081

1. When completing DD Form 1081 to obtain advances of funds—
 - a. Enter the FM Treasury account holder and agent/cashier/DO identification in the blocks provided.
 - b. On line 1, under "BEGINNING BALANCE," enter the current accountability of the agent, cashier, or DO.
 - c. Enter the following information under the "INCREASE" column:
 - (1) Lines 2 thru 4—Enter the amount of currency by type included in the advance. If foreign currency is advanced, enter the U.S. dollar amount in the column and show the amount of foreign currency and its exchange rate to the side.
 - (2) Line 7—Enter the amount of U.S. Treasury checks and/or any other negotiable instruments in the advance. Enter the beginning and ending check numbers on the corresponding line (as appropriate).
 - (3) Line 9—Enter the dollar amount of incorrect vouchers returned.
 - (4) Lines 10 and 11—Enter items other than those described above that are included in the advance. Ensure that any such items are appropriately identified.
 - d. Enter the total of the amounts entered on lines 1 thru 11 in the column under "BEGINNING BALANCE." This total represents the balance in the agent, cashier, or DO account as a result of the advance. This balance also must be entered on line 1 in the ending balance column.
 - e. The deputy or DO making the advance places an "X" in the box provided opposite the "ON ADVANCE" statement to indicate that the form is to account for an advance of funds to the agent, cashier, or DO. Complete the DATE and SIGNATURE blocks to authenticate the statement opposite the box checked.
 - f. The agent, cashier, or DO verifies that the items received are in agreement with the amounts stated on the form. The agent, cashier, or DO then places an "X" in the box provided opposite the agent, cashier, or DO officer "ON ADVANCE" statement. The agent, cashier, or DO completes the DATE and SIGNATURE blocks to authenticate the statement and to certify that he/she understands the applicable instructions.
 - g. The deputy or DO making the advance gives copy three to the agent, cashier, or DO, and retains the original and copy two. If the advance is to a paying agent, the agent, cashier, or DO also retains a copy of the agent orders with the original DD Form 1081.
2. When completing DD Form 1081 to process returned funds—
 - a. Enter the following information under the "DECREASE" column:
 - (1) Lines 2 through 4—Enter the amount of currency included in the return. Use the same exchange rate for foreign currency as the one used in the advance. List the amount of foreign currency next to the dollar equivalent amount.

Appendix R

Instructions for Completing DD Form 1081 (continued)

- (2) Line 5—Enter the amount of collections made by the agent, cashier, or DO in the form of cash or negotiable instruments.
 - (3) Line 6—N/A.
 - (4) Line 7—Enter the amount of checks and/or negotiable instruments returned to the deputy or DO (for example, checks cashed, and U.S. Treasury checks previously advanced but not used).
 - (5) Line 8—Enter the amount of vouchers paid by the agent, cashier, or DO.
 - (6) Lines 10 and 11—Enter items other than those described above that are included in the return. Ensure that any such items are appropriately identified.
- b. Enter the total shown on line one, minus the amounts in the “DECREASE” column, on line 12 under the “ENDING BALANCE” column. This amount represents the ending balance in the agent, cashier, or DO account as a result of the return.
- (1) The agent, cashier, or DO places an “X” in the box provided opposite the “ON RETURN” statement and completes the DATE and SIGNATURE blocks.
 - (2) The deputy verifies the amounts on the form, and if correct, places an “X” in the box opposite the ON RETURN statement and completes the DATE and SIGNATURE blocks.
 - (3) The deputy gives the original form to the agent, cashier, or CCO, and keeps copy 2.
 - (4) If the agent, cashier, or CCO has an ending balance, prepare a new DD Form 1081 using the previous DD Form 1081’s ending balance as the beginning balance. Put the increases and decreases in the appropriate columns and then determine the new ending balance.

Appendix S

Processing of Enemy Prisoners of War and Civilian Internees and Captured Currency

This Appendix is intended to outline, in general terms, the procedures used for in-processing and out-processing enemy prisoners of war (EPWs) and civilian internees (CIs) and captured currency. Unit tactical SOPs can use this outline as a guide and expand and modify it, as appropriate, to meet command policies and procedures.

REFERENCES

- S-1. The following references provide additional information on finance processing of EPWs and CIs:
- DFAS-IN Reg 37-1 (Chapter 36).
 - AR 190-8.
 - FM 27-10.
 - Geneva Convention Relative to the Treatment of Prisoners of War.
 - Geneva Convention Relative to the Protection of Civilian Persons in Time of War.
 - DOD 7000.14-R.

RESPONSIBILITIES

S-2. In accordance with DFAS-IN Reg 37-1, financial management leaders are responsible for processing deposits to and payments from, appropriated, deposit, trust, or other special fund accounts. They are also responsible for ensuring disbursements from these accounts are not made without specific authority. FM leaders advise the internment facility commander on internment and resettlement (I/R) operations that relate to pay and accounting. Upon request, FM units provide training to personnel assigned to the camp or I/R unit.

S-3. Captured currency (enemy, allied, neutral, or U.S.) is immediately turned in to the nearest FM unit for control, accountability and safekeeping. Personnel taking possession of captured currency are responsible for counting, safeguarding, and transporting currency to the nearest financial management unit. Captured currency is inventoried by two disinterested individuals. When the inventory is completed, the disbursing agent or deputy issues an SF 1165 (Receipt for Cash—Subvoucher) as receipt of the collection and to establish an audit trail for the transaction. The agent or deputy then forwards a copy through financial management channels and requests disposition instructions. When disposition instructions are received, the deputy processes a cash collection voucher (DD Form 1131), listing as many details as possible on the form to assist in identifying the funds. The deputy attaches the original receipt and the completed SF 1165 to the DD Form 1131 as backup documentation. In the event large sums of currency are discovered and seized, additional safeguards and disposition instructions are required. Accountable officers must immediately contact senior FM leadership (FMC Chief, G8, USAFINCOM) for guidance and assistance. At no time will these funds be taken into accountability and utilized for any purpose until proper disposition instructions are received.

**Standing Operating Procedures for
Finance Processing of EPWs/CIs if the
Prisoner of War Information System (PWIS) is Not Available**

The following instructions are for FM leaders:

1. When an EPW/CI is in-processed, the military police (MP) unit in charge of the EPW camp completes a DA Form 4237-R (Detainee Personnel Record), a DA Form 1132-R (Prisoner's Personal Property List – Personal Deposit Fund), or a suitable locally produced form.
2. If the EPW/CI possesses foreign currency, account for and maintain funds in safekeeping, in accordance with AR 190-8.
3. If an investigation is necessary, deposit the funds into Deposit Fund Account 21X6875 (Suspense). If the investigation determines that the EPW/CI has legal claim to the currency, transfer the amount from Deposit Fund Account 21X6875 to Deposit Fund Account 21X6015.
4. Distribute DD Form 1131 as follows:
 - a. Original. Retain as a substantiating document.
 - b. Copy 2. Retained by disbursing officer (DO).
 - c. Copy 3. Attach to envelope containing the collected funds.
 - d. Copy 4. Attach to EPW/CI's DA Form 4237-R.
 - e. Copy 5. Give to EPW/CI.
5. Advances of pay and monthly allowances. The start date for pay purposes is the earlier of the date of capture or the date of classification as an EPW/CI. If one of these dates is not known, use the other.
 - a. CIs. The EPW/CI facility commander establishes the monthly amount of allowances by policy direction.
 - b. EPWs. The amount of monthly allowances is determined by rank, as prescribed in DFAS-IN Reg 37-1.
6. **Work Pay.** EPWs/CIs are entitled to remuneration for work performed that is in addition to advance pay. Use piece work or task system rates, when applicable. If not applicable, use the pay rate schedules in AR 190-8.
7. **Payment for labor under contract.** Record amounts received into DO Deposit Fund Account 21X6015. Deposit any remaining amounts into Deposit Fund Account 21X3210, General Fund Miscellaneous Income and Recoveries Not Otherwise Classified.
8. **Charges for items purchased.** Charge items purchased to the specific EPW/CI and to DO Deposit Fund Account 21X6015. Reimburse the account owning the items purchased, priced in accordance with AR 190-8.
9. **Accounting for amounts due EPWs/CIs.** Use the following forms to account for EPW/CI funds:
 - a. Individual Pay Data Record—EPWs/CIs. Prepared monthly to maintain the current balance due each EPW/CI. See sample format in DFAS-IN Reg 37-1, Chapter 26, figure 26-3.
 - b. Statement of Credit Balance—EPWs/CIs. See sample format in DFAS-IN Reg 37-1, Chapter 26, figure 26-7.
10. **Transfers.** Transfer the applicable balance in DO Deposit Fund Account 21X6015 by TFO to the gaining camp's servicing FM unit. Attach a copy of the individual pay data record for the EPW/CI.
11. **Final settlement.** Make final settlement for all amounts due the EPW/CI upon his/her transfer to another country, repatriation, death, or escape.
 - a. Prepare and certify the Statement of Credit Balance —EPWs/CIs, marked "final."
 - b. Pay the individual any funds due. Provide a written statement explaining that his/her country is responsible for amounts due per Article 66 of the Geneva Convention Relative to the Treatment of Prisoners of War.

Processing of Enemy Prisoners of War and Civilian Internees and Captured Currency

- c. Return the CI's articles and funds taken from them for safekeeping.
- d. Return the EPW's articles that were being held for safekeeping.
- e. Transfer remaining balances in DO Deposit Fund Account 21X6015 to Deposit Fund Account 21R1060, Miscellaneous Receipt Account.

This page intentionally left blank.

Appendix T

Strategic Reimbursement Procedures

This Appendix includes general descriptions of strategic reimbursement procedures.

NONCOMBATANT EVACUATION OPERATION

T-1. Reimbursement procedures for noncombatant evacuation operations (NEOs) are accomplished in accordance with existing memoranda of agreement (MOAs) between the Department of State and the Department of Defense. Contact USDI or Service financial managers for provisions of existing MOAs.

UN REIMBURSEMENT PROCEDURES

T-2. For UN operations, reimbursements fall into one of four categories: UN determined costs, invoiced costs, letters of assist (LOAs), and leases.

UN DETERMINED COSTS

T-3. Reimbursement for determined costs is accomplished at the DOD level. Components should ensure accurate personnel figures are reported to the UN headquarters in-theater and included on monthly cost reports submitted to DFAS. These personnel counts form the basis for reimbursement calculations.

INVOICED COSTS

T-4. The financial manager prepares requests for reimbursement of invoiced costs based upon cost reports. The financial manager ensures auditable documentation is available to validate and substantiate amounts reported on the cost reports. Financial managers need the logisticians to provide an accurate updated status of supplies, such as fuel provided to NGOs, and other non-DA organizations. In most cases, only the incremental amount is billable to the other units, installations, or sister Services. For additional information, refer to DOD 7000.14-R, Volume 12, Chapter 23.

LETTER OF ASSIST COSTS

T-5. Reimbursement for LOA costs is accomplished using a voucher for transfer SF 1080. Financial managers should prepare an SF 1080 voucher for the cost of the goods or services provided and reference the LOA number. All LOAs must be forwarded to the Defense Security Cooperation Agency (DSCA) for execution and billing procedures. The voucher, with sufficient detailed documentation and the appropriate UN receipt records, should be forwarded through financial channels to the UN. An official authorized to commit funds should validate the voucher before it is sent through U.S. financial channels for reimbursement. This validation expedites the processing of the bill at UN Headquarters in New York. Timely and accurate voucher submission is essential to ensure the most efficient repayment of funds. The financial manager and or DFAS field site forwards the SF 1080 to DFAS with supporting documentation and a certified contingency operations cost report to support the bill. All vouchers must provide adequate documentation for accountability and certification. DFAS verifies the LOA number and item for which a voucher is being submitted, summarizes it in a separate attachment, and forwards the voucher to the U.S. Mission to the UN for transmission to the UN. The UN will not accept a bill that exceeds the UN LOA

Appendix T

ceiling. The JTF financial manager must notify DSCA if the billable costs will exceed the UN LOA. DSCA will then negotiate an LOA amendment or revision with the UN to allow for additional costs.

LEASES

T-6. Leases of major end items, and the associated foreign military sales (FMS) support cases, are managed by the DSCA. Development of leases for DOD equipment follows normal procedures in DOD 5105.38M, Chapter 11, which are governed by the Arms Export Control Act.

NATO REIMBURSEMENT PROCEDURES

SUPPORT ARRANGEMENTS WITH NATO

T-7. The NATO theater headquarters accurate personnel counts are required to ensure proper reimbursement calculations. NATO headquarters sometimes requires specialized sustainment support from one or more of the contributing nations. Such support, when included in the mission statement of requirements, is generally requested as a mission contribution on a nonreimbursable basis (for example, provision of medical capabilities). In other instances, the NATO headquarters may request consumable supplies or other support (for example, fuel) on a reimbursable basis. The financial manager submits the SF 1080 to DFAS with sufficient detailed documentation and a certified contingency operations cost report to support the request for reimbursement. During out-of-area operations, reimbursable arrangements with NATO are usually executed as requests for case-by-case reimbursable support or as an acquisition and cross-servicing agreement (ACSA).

Requests for Case-by-Case Reimbursable Support

T-8. Requests for case-by-case reimbursable support (for example, military equipment such as vehicles) must originate with NATO and should include an advance commitment by the NATO theater financial controller stating reimbursement will be provided. Such costs are invoiced to the NATO theater headquarters for reimbursement by the NATO theater financial controller.

NATO Acquisition and Cross-Servicing Agreement

T-9. Bilateral acquisition and cross-servicing agreements (ACSAs) exist with many allied nations and the NATO Maintenance and Supply Organization, enabling operational commanders to arrange mutual support under payment in cash (PIC), replacement-in-kind (RIK), or equal value exchange (EVE) procedures.

SUPPORT ARRANGEMENTS WITH ALLIED NATIONS

T-10. NATO doctrine establishes that logistic support is a national responsibility; however, efficiencies should be sought wherever possible. Other allied nations' forces may require logistic support, which may be provided in a number of different ways. During peacetime, this is generally accomplished through the FMS program. During Article 5 (within NATO territories) or non-Article 5 (outside of NATO territory) operations, such support may be provided under the following arrangements:

- Role specialization arrangements.
- Standardization agreements (STANAGs).
- Direct reimbursement.

Role Specialization Arrangements

T-11. Prior to an operation, the nations providing forces may mutually agree to a division of responsibility in the theater. Such an arrangement, for example, could result in one nation establishing a field medical facility, with another nation providing an airlift capability. Ideally, NATO theater headquarter's tasks

requiring specialized logistic support from one or more of the contributing nations should be divided such that mutual benefit and equity are apparent and supported by law. This is an extremely valuable tool, because it provides a framework for exchange of available items to support time-sensitive mission requirements.

Standardization Agreements

T-12. NATO nations have made commitments to pursue standardization and interoperability in a number of areas. One means of achieving this is through adaptation of common technical standards and procedures, documented in standardization agreements (STANAGs). A body of such standardization documents exists, covering functions ranging from communications procedures to refueling other nations' aircraft. Many such agreements also include standard reimbursement procedures.

Direct Reimbursement

T-13. In the absence of other suitable arrangements, nations may negotiate for support subject to reimbursement procedures of the nation providing the required supplies or services.

HOST-NATION SUPPORT REIMBURSEMENT PROCEDURES

T-14. Once the host-nation support (HNS) agreement is established, the S4/G4/C4/J4 provides a detailed statement of requirements to the HN and begins the negotiations for logistic support. The use of O&M funds are authorized to support HN requirements. Specific procedures for cost capturing and billing must be negotiated with the HN and the United States. This will prevent locally negotiated agreements that may not be legal or authorized. The financial manager must submit the SF 1080 to DFAS with sufficient detailed documentation and a certified contingency operations cost report to support the request for reimbursement.

FOREIGN NATION SUPPORT REIMBURSEMENT PROCEDURES

CIRCUMSTANCES FOR SUPPORT

T-15. Foreign nation support (FNS) is support provided to foreign forces from countries other than the country in which the contingency operation is occurring. This support is generally provided under one of three circumstances—

- Support can be provided under the existing rules of a parent organization controlling the operation (for example, NATO, or the UN). Billing procedures under these circumstances should follow standing agreements for support. See Appendix E for a detailed discussion on several of the legal authorities for reimbursement, including the ACSA, Sections 607 and 632 of the FAA, and The Economy Act.
- Support may be provided if the United States and the supported country have a bilateral agreement in place prior to the operation. The United States has many of these cooperative agreements with allies. The resource manager must consult with the legal advisor for a copy of any existing bilateral agreements and follow the procedures outlined in the agreement for reimbursement.
- Support can be provided based upon an agreement negotiated expressly for the operation. Any negotiated agreement for support should include billing and reimbursement instructions.

BILLING

T-16. Bills prepared for support during a UN or NATO operation should follow procedures established by those organizations. Bills prepared for either standing or negotiated bilateral support agreements should be

Appendix T

processed as set out in the agreement. The financial manager must send these bills as required through Service funding channels.

ASSISTANCE IN KIND

T-17. Assistance in kind (AIK) operations, which deal directly with the governments of eligible countries, provide material and services for an NGO and logistic exchange of materials and services of equal value. These items are accountable as future reimbursements to the country that initially provides them on a gratis basis. Costs for these items have a current value that is captured as future reimbursements. The JTF financial manager develops and implements procedures, in coordination with sustainment elements, to track the value of support provided to ensure an equal exchange of valued materials and services throughout the operation. Particular care must be taken in accounting for these authorized exchanges due to the political sensitivity inherent in multinational operations. Ideally, these in kind reimbursements should derive no monetary gain and should provide mutual benefit and equity between the participating countries.

NONGOVERNMENTAL ORGANIZATION REIMBURSEMENT PROCEDURES

T-18. NGOs do not operate within the military or governmental hierarchy. However, because NGOs operate in remote areas of high risk, they may need the logistic, communication, and security support that military forces can provide. Expectations of military support (including supplies, services, and assistance) must be reviewed with the organizations. Financial managers must consult with a legal advisor to determine the authority to provide support on a reimbursable or nonreimbursable basis. Each organization normally has some type of financial control officer. Military activities should provide support only after they receive approval. Financial managers should ensure all supply activities, especially fuel, maintain a status of what is provided. Financial managers should submit bills to supported organizations, as required, and if the organization is not authorized to make payment locally, should forward the documentation (signed by both organizations) through Service funding channels.

NON-DOD GOVERNMENTAL AGENCIES REIMBURSEMENT PROCEDURES

T-19. Congress provides the DOD with funds for very specific needs. Therefore, support directly to other U.S. Government agencies can be complex. When presented with a request for support by a U.S. Government agency, financial managers should consult with the legal advisor. An MOA or letter requesting support should form the basis for any reimbursable relationship with non-DOD governmental agencies. This agreement can be used to ensure only authorized support is provided, and supply and service activities capture the cost of support. Bills should be compiled as required, using a manual SF 1080 bill, through the supported agency. The SF 1080 must have a copy of the agreement with attached substantiating documents.

Glossary

SECTION I – ACRONYMS AND ABBREVIATIONS

AAFES	Army and Air Force Exchange Service
AC	active component
ACRN	accounting classification reference number
ACSA	acquisition and cross-servicing agreement
ADCON	administrative control
ADVON	advanced echelon
AFSB	Army field support brigade
AIK	assistance in kind
AMDF	Army Master Data File
AMOPES	Army Mobilization and Operations Planning and Execution System
AMS	Army management structure
AMSCO	Army Management Structure Code
ANCD	automated net control device
AO	area of operations
APC	accounting processing code; armored personnel carrier
ARA	automatic reimbursable authority
ARFOR	Army forces
ASA(FM&C)	Assistant Secretary of the Army for Financial Management & Comptroller
ASCC	Army Service component command
ASOS	Army support to other Services
ATLAS	Accounting Transaction Ledger Archival System
ATM	automatic teller machine
AUM	assessable unit manager
AWCF-SMA	Army Working Capital Fund – Supply Management, Army
BA	budget activity
BAG	budget activity group
BASOPS	base operations
BCT	brigade combat team
BES	budget estimate submission
C2	command and control
CA	civil affairs
CAISI	Combat Service Support Automated Information Systems Interface
CAPS	Computerized Accounts Payable System
CARB	Combined Acquisition Review Board
CBE	command budget estimate
CBRN	chemical, biological, radiological, and nuclear

Glossary

CCO	cash control officer; contingency contracting officer
CEAC	cost and economic analysis center
CERP	commander's emergency response program
CI	civilian internee
CJCS	Chairman, Joint Chiefs of Staff
CLIN	contract line item number
COA	course of action
COMSEC	communications security
CONUS	continental United States
COR	contracting officer's representative
COTR	contracting officer's technical representative
COTS	commercial off-the-shelf
CP	casual payment; command post
CRA	continuing resolution authority
CSP	contracting support plan
CSRS	Civil Service Retirement System
CSS VSAT	combat service support very small aperture terminal
CTA	common table of allowances
CTC	combat training center
CVS	commercial vendor services
DA	Department of the Army
DbCAS	Dbase Commitment Accounting System
DD	Department of Defense (forms)
DDS	Deployable Disbursing System
DERA	Defense Environmental Restoration Account
DERF	Defense Emergency Response Fund
DFAS	Defense Finance and Accounting Service
DITY	do-it-yourself
DMO	Defense MilPay Office
DNVT	digital nonsecure voice terminal
DO	disbursing officer
DOD	Department of Defense
DODAAC	Department of Defense activity address code
DODAAD	Department of Defense Activity Address Directory
DODFMR	Department of Defense Financial Management Regulation
DOL	Director of Logistics
DOS	Department of State
DOTMLPF	doctrine, organizations, training, materiel, leadership and education, personnel, and facilities
DPI	data processing installation
DRN	document reference number

DSCA	Defense Security Cooperation Agency
DSIS	Defense MilPay Office Standard Inquiry System
DSSN	disbursing station symbol number
DTS	Defense Travel System
DWCF	Defense Working Capital Funds
E&E	emergency and extraordinary expense
EARS	Evaluation and Reporting System
EDA	excess defense articles
EFT	electronic funds transfer
EOR	element of resource
EPLRS	Enhanced Position Location Reporting System
EPW	enemy prisoner of war
ESF	Economic Support Fund
ETS	expiration term of service
EVE	equal value exchange
FAA	Foreign Assistance Act
FAD	funding authorization document
FAR	Federal Acquisition Regulation
FAX	facsimile terminal
FBE	field budget estimate
FCA	functional cost account
FEMA	Federal Emergency Management Agency
FHP	Flying Hours Program
FI	finance
FM	financial management
FM CO	financial management company
FM DET	financial management detachment
FMC	financial management center
FMF	foreign military financing
FMS	foreign military sales
FMST	financial management support team
FMTP	financial management tactical platform
FNS	foreign nation support
FOB	free on board
FOO	field ordering officer
FRA	funded reimbursable authority
FTCA	Foreign Tort Claims Act
FY	fiscal year
G1	Assistant Chief of Staff, Personnel
G2	Assistant Chief of Staff, Intelligence
G3	Assistant Chief of Staff, Operations and Plans

Glossary

G4	Assistant Chief of Staff, Logistics
G9	Assistant Chief of Staff, Civil Affairs
G8	Assistant Chief of Staff, Financial Management
GAO	General Accounting Office
GBL	government bill of lading
GPC	government purchase card
GPO	Government Printing Office
GSA	General Services Administration
GTR	government transportation requests
HCA	humanitarian and civic assistance
HHG	household goods
HMMWV	High-Mobility, Multipurpose Wheeled Vehicle
HN	host nation
HNS	host-nation support
HQ	headquarters
HQDA	Headquarters, Department of the Army
IATS	Integrated Automated Travel System
IAW	in accordance with
IBOP	international balance of payments
IC	internal control
ID	identification
IG	inspector general
ILAP	Integrated Logistics Analysis Program
IMET	international military education and training
IMPAC	international merchant purchase authorization card
IPL	integrated priority list
J2	Intelligence Directorate of a joint staff
J5	Plans Directorate of a joint staff
JARB	Joint Acquisition Review Board
JCS	Joint Chiefs of Staff
JFC	joint force commander
JFLCC	joint force land component commander
JFTR	joint Federal travel regulations
JHIM	joint, interagency, intergovernmental, and multinational
JMD	joint manning document
JOA	joint operations area
JON	job order number
JP	joint publication
JQRR	joint quarterly readiness review
JROC	Joint Requirements Oversight Council
JTF	joint task force

LD	local depository
LDA	limited depository account
LES	leave and earnings statement
LN	local national
LOA	letter of assist
LOGCAP	logistics civil augmentation program
MBF	military banking facility
MCA	management control administrator
MCP	management control program
MDEP	management decision evaluation package
MDMP	military decisionmaking process
METT-TC	mission, enemy, terrain and weather, troops and support available, time available, and civil considerations
MFR	memorandum for record
MILCON	military construction
MILSTRIP	military standard requisition and issue procedures
MIPR	military interdepartmental purchase request
MMC	material management center
MOA	memorandum of agreement
MOD	miscellaneous obligation document
MOU	memorandum of understanding
MOV	materiel obligation validation
MP	military police
MSE	mobile subscriber equipment
MSRT	mobile subscriber radio terminal
MTOE	modified table of organization and equipment
MWR	morale, welfare, and recreation
NAF	nonappropriated fund
NAFI	nonappropriated fund instrumentality
NATO	North Atlantic Treaty Organization
NCA	National Command Authority
NCOIC	noncommissioned officer in charge
NEO	noncombatant evacuation order (or operations)
NES	Network Encryption System
NGO	nongovernmental organization
NMS	National Military Strategy
NRI	network radio interface
NSFOP	non-stock fund orders and payables
NULO	negative unliquidated obligations
O&M	operation and maintenance
OCONUS	outside the continental United States

Glossary

OCP	operational command post
ODS	operational data store
OHDACA	overseas humanitarian, disaster, and civic aid
OMA	operations and maintenance Army
OMB	Office of Management and Budget
OPA	other procurement Army
OPLAN	operation plan
OPLOC	operating location
OPORD	operation order
OPRED	operational readiness
OPTEMPO	operating tempo
OSD	Office of the Secretary of Defense
PA	public affairs
PARC	principle assistant responsible for contracting
PBAC	program budget advisory committee
PBAS	Program Budget Accounting System
PBD	program budget decision
PCC	paper check conversion
PCH	packing, crating, and handling
PCS	permanent change of station
PDM	program decision memorandum
PDS	permanent duty station
PIC	payment in cash
PKO	peacekeeping operations
POC	point of contact
POE	port of embarkation
POL	petroleum, oils, and lubricants
POM	program objective memorandum
POV	privately owned vehicle
PPA	Prompt Payment Act
PPBE	planning, programming, budgeting, and execution
PR&C	purchase request and commitment
PWIS	Prisoner of War Information System
QAE	quality assurance evaluator
RC	Reserve Component
RDD/RAD	resource distribution document/resource allocation document
RDF	radio direction finding
RIK	replacement-in-kind
RITA	Relocation Income Tax Allowance
RM	resource management
S1	personnel staff officer

S2	intelligence staff officer
S4	logistics staff officer
S6	command, control, communications and computer operations (C4 Ops) officer
SAACONS	Standard Army Acquisition and Contract Network System
SAG	sub-activity group
SAM	security access module
SCCT	senior contingency contracting team
SDN	standard document number
SDP	savings deposit program
SF	standard form
SINGARS	single-channel ground and airborne radio system
SJA	Staff Judge Advocate
SO/LIC	special operations and low intensity conflict
SODEP	special operating decision package
SOFA	status of forces agreement
SOI	signal operating instructions
SOP	standing operating procedures
SPG	Strategic Planning Guidance
SPO	support operations
SRP	soldier readiness processing
STANAG	standardization agreement
STANFINS	Standard Financial System
SVC	stored value card
TAC	transportation account code
TAP	The Army Plan
TBD	to be determined
TCA	theater commander activity
TCN	transportation control number
TCS	temporary change of station
TDA	table of distribution and allowances
TDY	temporary duty
TFE	tactical field exchange
TOC	tactical operations center
TPA	time, purpose, and amount
TRADOC	United States Army Training and Doctrine Command
USTRANSCOM	United States Transportation Command
TRM	training resource model
TSC	theater sustainment command
U.S.	United States
UFR	unfinanced requirement; unfunded requirement
UIC	unit identification code

Glossary

ULLS	Unit Level Logistics System
UN	United Nations
UNAMIR	United Nations Assistance Mission in Rwanda
UNPA	United Nations Participation Act
USAFINCOM	United States Army Finance Command
USAID	U.S. Agency for International Development
USC	United States Code
USD(C)	Under Secretary of Defense (Comptroller)
USDP	Under Secretary of Defense for Policy
USSOCOM	United States Special Operations Command
USUN	United States Mission to the United Nations in New York
VERA	Voluntary Early Retirement Authority
VSIP	Voluntary Separation Incentive Program
WCF	Working Capital Fund
WFC	weapons for cash
WIAS	World Wide Integrated Augmentation System
YYMMDD	Year, month, day (two position numeric year, three position alpha month, and two position numeric day)

SECTION II – TERMS

administrative control. Direction or exercise of authority over subordinate or other organizations in respect to administration and support, including organization of Service forces, control of resources and equipment, personnel management, unit logistics, individual and unit training, readiness, mobilization, demobilization, discipline, and other matters not included in the operational missions of the subordinate or other organizations. Also called ADCON. (JP 1-02)

antideficiency violations. The incurring of obligations or the making of expenditure (outlays) in excess of amounts available in appropriations or funds. (JP 1-02)

area of operations. An operational area defined by the joint force commander for land and naval forces. Areas of operation do not typically encompass the entire operational area of the joint force commander, but should be large enough for component commanders to accomplish their missions and protect their forces. Also called AO. (JP 1-02)

Army Service component command. Command responsible for recommendations to the joint force commander on the allocation and employment of Army forces within a combatant command. Also called ASCC. (JP 1-02)

baseline costs. Baseline costs are the continuing annual costs of military operations funded by the operations and maintenance and military personnel appropriations. (This term and its definition are approved for inclusion in the next edition of JP 1-02)

combatant commander. A commander of one of the unified or specified combatant commands established by the President. (JP 1-02)

command and control. The exercise of authority and direction by a properly designated commander over assigned and attached forces in the accomplishment of the mission. Command and control functions are performed through an arrangement of personnel, equipment, communications, facilities, and procedures employed by a commander in

- planning, directing, coordinating, and controlling forces and operations in the accomplishment of the mission. Also called C2. (JP 1-02)
- component.** 1. One of the subordinate organizations that constitute a joint force. Normally a joint force is organized with a combination of Service and functional components. 2. In logistics, a part or combination of parts having a specific function, which can be installed or replaced only as an entity. (JP 1-02)
- continental United States.** United States territory, including the adjacent territorial waters, located within North America between Canada and Mexico. Also called CONUS. (JP 1-02)
- contracting officer.** A U.S. military officer or civilian employee who has a valid appointment as a contracting officer under the provisions of the Federal Acquisition Regulation. The individual has the authority to enter into and administer contracts and determinations and findings about such contracts. (JP 1-02.)
- dislocated civilian.** A broad term that includes a displaced person, an evacuee, an expellee, an internally displaced person, a migrant, a refugee or a stateless person. (JP 1-02)
- finance operations.** The execution of the joint finance mission to provide financial advice and guidance, support the procurement process, providing pay support, and providing disbursing support. See also financial management. (JP 1-02)
- financial management.** Financial management encompasses the two core processes of resource management and finance operations. Also called FM. See also finance operations; resource management operations. (JP 1-02)
- foreign nation support.** Civil and/or military assistance rendered to a nation when operating outside its national boundaries during war, or operations other than war based on agreements mutually concluded between nations or on behalf of international organizations. Support may come from the nation in which forces are operating. Foreign nation support also may be from third party nations and include support or assistance, such as logistics, rendered outside the operational area. Also called FNS. See also host-nation support. (JP 1-02)
- host nation.** A nation that receives the forces and/or supplies of allied nations, coalition partners, and/or NATO organizations to be located on, to operate in, or to transit through its territory. Also called HN. (JP 1-02)
- host-nation support.** Civil and/or military assistance rendered by a nation to foreign forces within its territory during peacetime, crises or emergencies, or war based on agreements mutually concluded between nations. Also called HNS. See also host nation. (JP 1-02)
- humanitarian and civic assistance.** Assistance to the local populace provided by predominantly US forces in conjunction with military operations and exercises. This assistance is specifically authorized by title 10, United States Code, section 401, and funded under separate authorities. Assistance provided under these provisions is limited to (1) medical, dental, and veterinary care provided in rural areas of a country; (2) construction of rudimentary surface transportation systems; (3) well drilling and construction of basic sanitation facilities, and (4) rudimentary construction and repair of public facilities. Assistance must fulfill unit training requirements that incidentally create humanitarian benefit to the local populace. Also called HCA. (JP 1-02)
- incremental costs.** Costs which are additional costs to the Service appropriations that would not have been incurred absent support of the contingency operation. (JP 1-02)
- joint force commander.** A general term applied to a combatant commander, sub-unified commander, or joint task force commander authorized to exercise combatant command (command authority) or operational control over a joint force. Also called JFC. (JP 1-02)

Glossary

- joint force land component commander.** The commander within a unified command, subordinate unified command, or joint task force responsible to the establishing commander for making recommendations on the proper employment of assigned, attached, and/or made available for tasking land forces; planning and coordinating land operations; or accomplishing such operational missions as may be assigned. The joint force land component commander is given the authority necessary to accomplish missions and tasks assigned by the establishing commander. Also called JFLCC. (JP 1-02)
- joint operations area.** An area of land, sea, and airspace, defined by a geographic combatant commander or subordinate unified commander, in which a joint force commander (normally a joint task force commander) conducts military operations to accomplish a specific mission. Joint operations areas are particularly useful when operations are limited in scope and geographic area or when operations are to be conducted on the boundaries between theaters. Also called JOA. (JP 1-02)
- joint task force.** A joint force that is constituted and so designated by the Secretary of Defense, a combatant commander, a sub-unified commander, or an existing joint task force commander. Also called JTF. (JP 1-02)
- letter of assist.** A contractual document issued by the United Nations (UN) to a government authorizing it to provide goods or services to a peacekeeping operation; the UN agrees either to purchase the goods or services or authorizes the government to supply them subject to reimbursement by the UN. A letter of assist typically details specifically what is to be provided by the contributing government and establishes a funding limit that cannot be exceeded. Also called LOA. (JP 1-02)
- military payment certificates.** An instrument (scrip) denominated in U.S. dollars that is used as the official medium of exchange in U.S. military operations designated as military payment certificate areas. Also called MPC. (JP 1-02)
- multinational operations.** A collective term to describe military actions conducted by forces of two or more nations, usually undertaken within the structure of a coalition or alliance. (JP 1-02)
- nation assistance.** Civil and/or military assistance rendered to a nation by foreign forces within that nation by foreign forces within that nation's territory during peacetime, crises or emergencies, or war, based on agreements mutually concluded between nations. Nation assistance programs include, but are not limited to, security assistance, foreign internal defense, other US Code title 10 (DOD) programs, and activities performed on a reimbursable basis by Federal agencies or international organizations. (JP 1-02)
- noncombatant evacuation operations.** Operations directed by the Department of State, the Department of Defense, or other appropriate authority whereby noncombatants are evacuated from foreign countries when their lives are endangered by war, civil unrest, or natural disaster to safe havens or to the United States. Also called NEOs. (JP 1-02)
- nongovernmental organizations.** Transnational organizations of private citizens that maintain a consultative status with the Economic and Social Council of the United Nations. Nongovernmental organizations may be professional associations, foundations, multinational businesses, or simply groups with a common interest in humanitarian assistance activities (development and relief). Also called NGOs. (JP 1-02)
- operational control.** Command authority that may be exercised by commanders at any echelon at or below the level of combatant command. Operational control is inherent in combatant command (command authority) and may be delegated within the command. When forces are transferred between combatant commands, the command relationship the gaining commander will exercise (and the losing commander will relinquish) over these forces must be specified by the Secretary of Defense. Operational control is the

authority to perform those functions of command over subordinate forces involving organizing and employing commands and forces, assigning tasks, designating objectives, and giving authoritative direction necessary to accomplish the mission. Operational control includes authoritative direction over all aspects of military operations and joint training necessary to accomplish missions assigned to the command. Operational control should be exercised through the commanders of subordinate organizations. Normally this authority is exercised through subordinate joint force commanders and Service and/or functional component commanders. Operational control normally provides full authority to organize commands and forces and to employ those forces as the commander in operational control considers necessary to accomplish assigned missions; it does not, in and of itself, include authoritative direction for logistics or matters of administration, discipline, internal organization, or unit training. Also called OPCON. (JP 1-02)

resource management operations. The execution of the resource management mission that includes providing advice and guidance to the commander, developing command resource requirements, identifying sources of funding, determining cost, acquiring funds, distribution and controlling funds, tracking costs and obligations, cost capturing and reimbursement procedures, and establishing a management control process. (JP 1-02)

This page intentionally left blank.

References

SOURCES USED

These are the sources quoted or paraphrased in this publication.

INTERNATIONAL LEGAL DOCUMENTS

Geneva Convention Relative to the Treatment of Prisoners of War (12 August 1949).

[Note: This document can be found online at <http://www.unhcr.ch/html/intinst.htm>.]

Geneva Convention Relative to the Protection of Civilian Persons in Time of War (12 August 1949).

[Note: This document can be found online at <http://www.unhcr.ch/html/intinst.htm>.]

North Atlantic Treaty.

[Note: This document can be found online at <http://www.nato.int/docu/basicxt/treaty.htm>.]

UNITED STATES LEGAL DOCUMENTS

UNITED STATES CODE

[Note: A searchable version of the U.S. Code can be found online at <http://uscode.house.gov>]

10 USC 127.

10 USC 166a.

10 USC 402.

10 USC 404.

10 USC 2342.

10 USC 2396.

10 USC 2551.

10 USC 2557.

10 USC 2803.

10 USC 2804.

10 USC 2805.

10 USC 2808.

22 USC 287d-1.

22 USC 2321j.

22 USC 2751, Ch 39, "Arms Export Control Act"

22 USC 2761.

31 USC 902, Ch 9, "Agency Chief Financial Officers"

31 USC 1341, 1342, 1344, and 1511-1517, "The Antideficiency Act"

31 USC 1501.

31 USC 1535.

31 USC 1552.

31 USC 1555.

31 USC 1557.

31 USC 3324.

37 USC 303.

40 USC 1412.

Section 3732 of the Revised Statutes (41 USC 11). "Feed and Forage Act"

References

41 USC 11a.
42 USC 5121.

PUBLIC LAWS

Public Law 79-264, United Nations Participation Act of 1945.

Public Law 81-351, Career Compensation Act of 1949.

Public Law 85-804, Indemnification.

Public Law 87-195, Foreign Assistance Act of 1961, as amended (FAA) (sections 506, 531, 541-545, 551, 552, 607, 628, 632).

Public Law 87-510, The Migration and Refugee Assistance Act of 1962.

Public Law 90-629, Arms Export Control Act, as amended.

[Note: Public Law 90-629, "The Foreign Military Sales Act of 1968," was amended by Public Law 94-329, "The International Security Assistance and Arms Export Control Act of 1976," and they are commonly referred to as the "Arms Export Control Act (AECA)."]

Public Law 97-177, The Prompt Payment Act, as amended.

Public Law 97-255 Federal Managers' Financial Integrity Act of 1982, as amended.

Public Law 97-258, The Economy Act.

Public Law 100-707, The Stafford Disaster Relief and Emergency Assistance Act.

Public Law 101-576, Chief Financial Officers Act of 1990.

Public Law 103-337, National Defense Authorization Act for FY 1995.

Public Law 103-356, Federal Financial Management Act of 1994.

[Note: The Federal Financial Management Act of 1994 is the same as the Government Management and Reform Act of 1994. Both titles are used to refer to this particular Act.]

FEDERAL REGULATIONS

[Note: These documents are available online at <http://www.dtic.mil/perdiem/trvlregs.html>.]

Joint Federal Travel Regulation, Volume 1—Uniformed Service Members.

Joint Federal Travel Regulation, Volume 2—Department of Defense Civilian Personnel.

OFFICE OF MANAGEMENT AND BUDGET PUBLICATIONS

OMB Circular No. A-11, Part 4. Instructions on Budget Execution. June 2002 (Sections 120, 121, 130, and Appendix F revised May 2003).

[Note: This document can be found online at <http://www.whitehouse.gov/omb/circulars/index.html>.]

GENERAL ACCOUNTING OFFICE PUBLICATIONS

AIMD-00-21.3.1. Standards for Internal Control in the Federal Government. November 1999.

[Note: This document can be found online at <http://www.gao.gov/>.]

DEPARTMENT OF DEFENSE PUBLICATIONS

DOD 7000.14-R. Department of Defense Financial Management Regulations (FMRs), including the following volumes

[Note: These volumes are available online at <http://www.dod.mil/comptroller/fmr/>.]

Volume 3. Budget Execution—Availability and Use of Budgetary Resources. December 1996 (with changes through January 2001).

Volume 5. Disbursing Policy and Procedures. October 2003.

Volume 12. Special Accounts Funds and Programs. August 2002.

Volume 14. Administrative Control of Funds and Antideficiency Act Violations. October 2001.

Volume 15. Security Assistance Policy and Procedures. August 2003.

DEFENSE FINANCE AND ACCOUNTING SERVICE PUBLICATIONS

[Note: The Defense Finance and Accounting Service (DFAS) publications are available online at <http://www.asafm.army.mil>.]

DFAS-IN Manual 37-100-04. The Army Management Structure, Fiscal Year 2004. August 2003.
Change 3, 17 October 2003.

DFAS-IN Regulation 37-1. Finance and Accounting Policy Implementation. January 2000 (with changes through March 2003).

DEFENSE FAR SUPPLEMENT

DFARS Part 204, Subpart 204.70—Uniform Procurement Instrument Identification Numbers.
(Revised 14 February 2003.)

[Note: This document can be found online at <http://www.acq.osd.mil/dpap/dfars/index.htm>]

DOD DIRECTIVES

DOD Directive 5530.3. International Agreements. 11 June 1987.

DOD Directive 7200.1. Administrative Control of Appropriations. 4 May 1995.

JOINT AND MULTISERVICE PUBLICATIONS

CJCSM 3500.04C. Universal Joint Task List (UJTL). 1 July 2002.

JP 1-02. DOD Dictionary of Military and Associated Terms. 12 April 2001, as amended through 9 May 2005.

JP 1-06. Joint Tactics, Techniques, and Procedures for Financial Management During Joint Operations. 22 December 1999.

DEPARTMENT OF THE ARMY PUBLICATIONS

AR 11-2. Management Control. 1 August 1994.

AR 25-2. Information Assurance. 14 Nov 2003.

AR 27-20. Claims. 1 July 2003.

AR 30-22. The Army Food Program. 5 October 2005.

AR 37-47. Representation Funds of the Secretary of the Army. 12 March 2004.

AR 190-8. Enemy Prisoners of War, Retained Personnel, Civilian Internees and Other Detainees. 1 October 1997.

AR 350-28. Army Exercises. 9 December 1997.

AR 700-137. LOGCAP. 16 December 1985 (currently being consolidated into AR 715-9).

AR 735-5. Policies and Procedures for Property Accountability. 28 February 2005.

FM 3-0. Operations. 14 June 2001.

FM 3-07. Stability Operations and Support Operations. 20 February 2003. Change 1, 30 April 2003.

FM 4-93.41. Army field Support Brigade (in development).

FM 27-10. The Law of Land Warfare. 18 July 1956. Change 1, 15 July 1976.

FM 100-10-2. Contracting Support on the Battlefield. 4 August 1999.

USAMC PAM 700-30. August 2004.

STANDARD FORMS

[See <http://www.gsa.gov/Portal/gsa/ep/formslibrary.do?formType=SF>]

SF 1. Printing and Binding Requisition to the Public Printer.

SF 30. Amendment of Solicitation/Modification of Contract.

SF 33. Solicitation, Offer, and Award.

SF 44. Purchase Order-Invoice-Voucher. (to include 44a, 44b, 44c, and 44d).

References

SF 50-B. Notification of Personnel Action.
 SF 1034 and 1034A. Public Voucher for Purchases and Services Other Than Personal.
 SF 1080. Voucher for Transfers Between Appropriations and/or Funds.
 SF 1103A. (U.S. Government Bill of Lading (GBL)—Memorandum Copy).
 SF 1164. Claim for Reimbursement for Expenditures on Official Business.
 SF 1165. Receipt for Cash—Subvoucher.
 SF 1169. U.S. Government Transportation Request.
 SF 1203. U.S. Government Bill of Lading—Privately Owned Personal Property.
 SF 1442. Solicitation, Offer and Award (Construction, Alteration or Repair).
 SF 2806. Individual Retirement Record (CSRS).

DEPARTMENT OF DEFENSE FORMS

DD Form 282. DOD Printing Requisition/Order.
 DD Form 448. Military Interdepartmental Purchase Request.
 DD Form 448-2. Acceptance of MIPR.
 DD Form 652. Uniformed Services Meal Ticket.
 DD Form 1081. Statement of Agent Officer's Account.
 DD Form 1131. Cash Collection Voucher.
 DD Form 1144. Support Agreement.
 DD Form 1155. Order for Supplies or Services.
 DD Form 1348-1A. Issue Release/Receipt Document.
 DD Form 1351-6. Multiple Payments List.
 DD Form 1556. Request, Authorization, Agreement, Certification of Training and Reimbursement.
 DD Form 1588. Record of Travel Payments.
 DD Form 1610. Request and Authorization for TDY Travel of DOD Personnel.
 DD Form 1614. Request/Authorization for DOD Civilian Permanent Duty or Temporary Change of Station (TCS) Travel.
 DD Form 2406. Miscellaneous Obligation Document.
 DD Form 2664. Currency Exchange Record.
 DD Form 2761. Personal Check Cashing Agreement.

DEPARTMENT OF THE ARMY FORMS

DA Form 11-2-R. Management Control Evaluation Certification Statement.
 DA Form 67-9-1. Officer Evaluation Report Support Form.
 DA Form 1132-R Prisoner's Personal Property List—Personal Deposit Fund.
 DA Form 1256. Incentive Award Nomination and Approval.
 DA Form 2028. Recommended Changes to Publications and Blank Forms.
 DA Form 2441. Suggestion Award Certificate.
 DA Form 3953. Purchase Request and Commitment.
 DA Form 4137. Evidence/Property Custody Document.
 DA Form 4237-R. Detainee Personnel Record.
 DA Form 7222-1. Senior System Civilian Evaluation Report Support Form.

U.S. GOVERNMENT PRINTING OFFICE FORMS

GPO Form 1026A. Print order for Marginally Punched Continuous Forms.
 GPO Form 2511. Print Order.

OTHER PUBLICATIONS

The World Fact Book. Central Intelligence Agency.

[Note: An online version of this document is available at <http://www.cia.gov/cia/publications/factbook/>. The online Factbook is updated regularly—generally weekly—throughout the year.]

DSCA(P)1239 (Formerly DD ISA(P)1226). *Roster of Key Security Assistance Personnel Worldwide*.
Defense Security Cooperation Agency.

AMC PAM 700-30. Logistics Civil Augmentation Program (LOGCAP).

READINGS RECOMMENDED

These sources contain relevant supplemental information.

DOD 7000.14-R. Department of Defense Financial Management Regulations (FMRs).

Volume 2. Budget Formulation and Presentation (parts A and B). June 2004.

Volume 4. Accounting Policy and Procedures. October 2003.

Volume 7a. Military Pay Policy and Procedures—Active Duty and Reserve Pay. July 2005.

Volume 7b. Military Pay Policy and Procedures—Retired Pay. July 2005.

Volume 7c. Special Military Pay/Personnel Program and Operating Procedures. August 2002.

Volume 10. Contract Payment Policy and Procedures. April 2002.

Volume 11a. Reimbursable Operations, Policy and Procedures. June 2005.

Volume 11b. Reimbursable Operations, Policy and Procedures—Working Capital Funds (WCF).
October 2002.

DOD Directive 1404.10. Emergency-Essential (E-E) DOD US Citizen Civilian Employees. 10 April 1992.

DOD Directive 5100.1. Functions of the Department of Defense and Its Major Components. 1 August 2002.

DOD Directive 5100.3. Support of the Headquarters of Combatant and Subordinate Joint Commands. 15 November 1999, Change 1, 23 March 2000.

CJCSI 3290.01A. Program for Enemy Prisoners of War, Retained Personnel, Civilian Internees, and Other Detained Personnel. 15 October 2000.

CJCSM 3122.03A. Joint Operation Planning and Execution System Volume II, (Planning Formats and Guidance). 31 December 1999. Change 1, 6 September 2000.

JP 1-01. Joint Doctrine Development System. 5 July 2000. Change 1, 29 June 2001.

JP 3-0. Doctrine for Joint Operations. 10 September 2001.

JP 3-07. Joint Doctrine for Military Operations Other Than War. 16 June 1995.

JP 3-07.3. Joint Tactics, Techniques, and Procedures for Peace Operations. 12 February 1999.

JP 3-08. Interagency Coordination During Joint Operations, Volumes I and II. 9 October 1996.

JP 3-16. Joint Doctrine for Multinational Operations. 5 April 2000.

JP 5-0. Doctrine for Planning Joint Operations. 13 April 1995.

JP 5-00.2. Joint Task Force Planning Guidance and Procedures. 13 January 1999.

AR 1-1. Planning, Programming, Budgeting, and Execution. 30 January 1994.

Air Force Instruction 10-213. Comptroller Operations Under Emergency Conditions. 22 July 1994.

Air Force Instruction 65-601. Volume 1, Budget Guidance and Procedures. 24 December 2002.

Air Force Pamphlet 65-110. Deployed Agent Operations. 10 October 2001.

Air Force Policy Directive 65-1. Management of Financial Services. 1 July 1996.

Navy Manual NAVSO P-1000. *Financial Management Policy Manual*. 02 April 1970. Change 67, 12 December 2002.

This page intentionally left blank.

Index

A

Acquisition and Cross-Servicing Agreements, 1-3, 1-22, E-6, E-9, T-2, T-3

Antideficiency Act, 1-16, A-1, A-2

AntiDeficiency Act, A-2

Army Mobilization and Operations Planning and Execution System, 1-4

Assistant Secretary of the Army for Financial Management & Comptroller, vi, 1-3, 1-8, 2-1, 2-7

B

banking support, B-2

C

CAISI, 3-3

Chief Financial Officers Act of 1990, A-3

civilian internee, 1-1, 1-3, B-3, C-2, S-1

coinage, D-8, J-1

communications security, 3-5

Continuing Resolution Authority (CRA), A-2

contracting support plan, 1-5

currency exchange, 1-7, 2-13, 2-14, D-7, H-10, K-2, L-1

D

Dbase Commitment Accounting System, 1-13, 1-20, 3-2

DD Form 1610, 1-21, H-4, H-22, H-23, H-24, H-25

Defense Finance and Accounting Service (DFAS), vi, 1-3, 1-6, 1-9, 1-20, 1-22, 1-26, 2-1, 2-7, 2-9, 3-2, B-2, C-1, C-2, E-7, F-2, H-33, J-1, T-1, T-2, T-3

Deployable Disbursing System, 3-2

destruction of currency, J-1

E

enemy prisoner of war (EPW), 1-1, 1-3, 2-11, 2-13, 2-14, A-3, B-3, C-2, S-1, S-2

Enhanced Position Location Reporting System, 3-4, 3-5

F

family support, B-2

Federal Financial Management Act, A-3

Federal Managers' Financial Integrity Act, A-3, I-1

Feed and Forage Act, A-3

Financial Management Support Team (FMST), 1-6, 2-13, 2-14, 3-4, 3-5, 3-7

fiscal triad, vii, 1-5

foreign currency, 1-1, 1-3, 1-6, 2-11, 2-14, B-2, D-3, D-7, D-8, E-4, H-10, H-34, L-1, M-2, N-1, O-2, P-1, Q-1, R-1, S-2

foreign disaster assistance, E-4

G

G3, 2-4

G4, B-1, I-2, T-3

G8, 1-9, 2-2, 2-3, 2-4, 2-5, 2-6, 2-7

H

host-nation support (HNS), 1-9, 1-23, B-1, B-2, T-3

humanitarian assistance, 1-22, 1-29, E-2, E-3, F-1

I

Integrated Automated Travel System (IATS), 3-2

L

Law of Armed Conflict, A-3

Logistics Civil Augmentation Program (LOGCAP), 1-26, E-4

M

multinational operations, 1-27, E-1, F-1, T-4, 10

N

non-U.S. pay support, 1-1, 2-10, 2-13, 2-14

O

operation plan (OPLAN), 1-28, B-1, B-2, C-1

P

paper currency, J-1

peace operations, 1-30, E-6, E-7, E-8, E-10, F-1

Prisoner of War Information System (PWIS), S-2

Purpose Statute, A-4

S

S1, 3-7, C-2

S2, C-2

S4, 3-7, T-3

S6, 3-7

Savings Deposit Program (SDP), 1-5, 1-7, 1-9

solatium payments, 1-3, 1-5, 1-9, B-2, D-3, O-1, O-3

Soldier Readiness Processing (SRP), 1-4

Staff Judge Advocate (SJA), vi, 1-7, B-1, B-2, B-3, O-1

T

travel support, 1-5, 1-8, 3-2, B-2, H-2, H-3, H-4, H-10, Q-1

U

United States Army Finance Command (USFINCOM), 1-3, 1-6, 2-1, 2-7, S-1

W

weapons for cash, 1-8, P-1

This page intentionally left blank.

FM 1-06
21 September 2006

By Order of the Secretary of the Army:

Official:



JOYCE E. MORROW

*Administrative Assistant to the
Secretary of the Army*

0624309

PETER J. SCHOOMAKER
*General, United States Army
Chief of Staff*

DISTRIBUTION:

Active Army, Army National Guard, and U. S. Army Reserve: To be distributed in accordance with initial distribution number 115473, requirements for FM 1-06.

