

MHI
Copy 3

FM 24-5

WAR DEPARTMENT

BASIC FIELD MANUAL

SIGNAL COMMUNICATION

1 Nov 1939

FM 24-5

BASIC FIELD MANUAL



SIGNAL COMMUNICATION

**Prepared under direction of the
Chief Signal Officer**



**UNITED STATES
GOVERNMENT PRINTING OFFICE
WASHINGTON : 1939**

WAR DEPARTMENT,
WASHINGTON, *November 1, 1939.*

FM 24-5, Basic Field Manual, Signal Communication, is published for the information and guidance of all concerned.

[A.G. 062.11 (7-17-39).]

BY ORDER OF THE SECRETARY OF WAR:

G. C. MARSHALL,
Chief of Staff.

OFFICIAL:

E. S. ADAMS,
Major General,
The Adjutant General.

TABLE OF CONTENTS

	Paragraphs	Pages
CHAPTER 1. GENERAL.		
Section I. General -----	1-4	1-2
II. Organization -----	5-9	3-5
III. Command and staff duties of signal and communication officers -----	10-12	5-7
CHAPTER 2. THE MESSAGE CENTER.		
Section I. General -----	13-24	9-20
II. Procedure for divisions and higher units -----	25-30	20-29
III. Procedure in headquarters below the division -----	31-36	29-36
IV. Related procedures -----	37-42	37-39
V. Military cryptography -----	43-49	40-47
VI. Description and use of cipher device M-94 -----	50-57	48-59
CHAPTER 3. MESSENGER COMMUNICATION.		
Section I. General -----	58-60	60-61
II. Training of personnel -----	61-66	61-63
III. Employment -----	67-76	63-68
IV. Dropped messages -----	77-80	69
V. Pick-up of messages -----	81-85	70-73
CHAPTER 4. PIGEON COMMUNICATION -----	86-89	74-77
CHAPTER 5. RADIO COMMUNICATION.		
Section I. General -----	90-97	81-86
II. Operating regulations -----	98-107	86-90
III. Station records -----	108-111	91-94
IV. Tactical radio nets -----	112-118	94-97
V. Special procedures -----	119	98
CHAPTER 6. VISUAL COMMUNICATION.		
Section I. General -----	120-121	99
II. Lamps -----	122-129	101-107
III. Flags -----	130-135	108-110
IV. Pyrotechnics -----	136-141	110-113
V. Panels -----	142-155	114-122
VI. Airplanes -----	156	124
CHAPTER 7. SOUND COMMUNICATION -----	157-160	125
CHAPTER 8. WIRE COMMUNICATION.		
Section I. General -----	161-183	126-145
II. Field wire line construction -----	184-206	145-193
III. Field telephones and centrals -----	207-225	195-224
IV. Field telegraph sets and stations -----	226-233	224-228
V. Maintenance of field wire systems -----	234-245	228-243
CHAPTER 9. SIGNAL SUPPLY -----	246-255	245-248
CHAPTER 10. ORDERS, RECORDS, AND REPORTS -----	256-262	249-257
Examples -----		258-284
Index -----		285

BASIC FIELD MANUAL

SIGNAL COMMUNICATION

(This pamphlet supersedes Basic Field Manual, Volume IV, April 6, 1931 (including C1, January 2, 1937 and C2, January 8, 1938); TR 75-10, May 16, 1927; TR 160-5, June 28, 1929; TR 162-5, April 20, 1926 (including C1, January 3, 1928, C2, January 2, 1929, and C3, January 2, 1930).

CHAPTER 1

GENERAL

SECTION		Paragraphs
I.	General	1-4
II.	Organization	5-9
III.	Command and staff duties of signal and communication officers	10-12

SECTION I

GENERAL

■ 1. **GENERAL.**—Signal communication provides essential channels through which a commander receives information and directs the actions of his troops. He uses signal communication to receive reports of hostile dispositions and activities, to receive reports of the progress and needs of subordinate and neighboring friendly units, to send orders to subordinate units, to receive orders from superior units, and to send to higher and adjacent units information necessary for the coordinated action of the whole command.

■ 2. **OBJECT.**—The object of this manual is to furnish basic technical information governing signal communication essential to officers and enlisted men engaged in signal activities.

■ 3. **SCOPE.**—The scope of this manual includes the methods and technique relating to the installation, operation, maintenance of, and planning for signal communication with special emphasis on such systems employed within the division and smaller units. Some of this basic information is also applicable to higher units.

■ 4. **REFERENCES.**—*a. Training publications.*—For a complete list of War Department training publications, see TR 1-10.

(1) *Technical Regulations*.—Technical Regulations set forth the information and instructions relative to specific items of equipment. These regulations are guides for training personnel in the installation, operation, and maintenance of the particular items of equipment. In general, those covering signal equipment fall within the TR 1200-series. (See also par. 98b).

(2) *Training Manuals*.—TM 2260-5 is of interest to all commanders whose headquarters are provided with a signal or communication unit and of special interest to officers engaged in signal communication.

(3) *Field Manuals*.—The following manuals contain pertinent matter relating to signal communication:

Field Service Regulations.

Staff Officers' Field Manual.

Signal Corps Field Manual.

b. *Miscellaneous*.—(1) *Army Regulations*.—Instructions relating to signal communication and Signal Corps activities are found in the AR 105-series.

(2) *Tables of Organization*.—Tables of Organization prescribe the organization of signal and communication units and personnel with qualifications thereof. They also show for purposes of information the items of transportation and weapons authorized for the respective unit.

(3) *Tables of Basic Allowances*.—Tables of Basic Allowances for the various arms and services contain a list of items of signal equipment authorized for signal or communication units of the respective arm or service together with the basis of issue for such items for both mobilization and peace.

(4) *Signal Corps General Catalog*.—The Signal Corps General Catalog includes a descriptive section which contains all items having signal corps type numbers arranged by type number; a stock section which contains all items in depot stocks arranged by stock number; and certain appendixes, Appendix B of which is supplemental to Tables of Basic Allowances. This catalog is essential to all signal property and supply officers.

(5) *Joint Army and Navy Radiotelegraph and Radiotelephone Procedure* (par. 99b).—The title is abbreviated as JANP.

SECTION II

ORGANIZATION

■ 5. DEFINITIONS.—*a. Message.*—The term “message” as used herein includes all instructions, reports, orders, documents, photographs, maps, etc., in plain language or code, transmitted by a means of signal communication. (See c below.)

b. Agency of signal communication.—The term “agency of signal communication” embraces the personnel and equipment necessary to operate message centers, signal intelligence, signal supply, and messenger, pigeon, radio, visual, sound, and wire communication.

c. Means of signal communication.—A “means of signal communication” is an agency of signal communication capable of transmitting messages. The following agencies are means of signal communication: messenger, pigeon, radio, visual, sound, and wire communication.

d. Command post.—The “command post” is the forward echelon of a headquarters during combat. When the commander leaves his command post for any purpose, he normally keeps the command post informed as to where he may be reached.

e. Axis of signal communication.—To secure continuity of command and signal communication in combat when the movement of command posts either forward or retrograde is contemplated, the probable successive locations of command posts should be selected in advance. The “axis of signal communication” is designated by naming these successive locations in the direction of movement.

■ 6. SIGNAL AND COMMUNICATION UNITS.—In general, Tables of Organization provide a signal or communication unit or units to serve each headquarters from the battalion to GHQ. The personnel of these units are either of the Signal Corps or of the arm or service of the headquarters served. Provision is made in Tables of Organization and Tables of Basic Allowances for necessary personnel and equipment to provide each headquarters with its needed signal communication.

■ 7. SIGNAL SYSTEMS.—The signal system serving each unit has a dual function. First, each tactical unit system is complete within itself and functions to meet the need of the unit commander; second, the system of each tactical unit forms an integral part of the systems of superior units and the whole functions to meet the need of the superior commander.

■ 8. DIVISION SIGNAL AGENCIES AND MEANS.—*a. Agencies.*—The following agencies of signal communication may be employed in the signal systems within the division:

- (1) *Message centers.*
- (2) *Messenger communication.*
 - (a) Airplane messenger.
 - (b) Motor messenger.
 - (c) Motorcycle messenger.
 - (d) Bicycle messenger.
 - (e) Mounted (horse) messenger.
 - (f) Dismounted messenger (runner).
- (3) *Pigeon communication.*
- (4) *Radio communication.*
 - (a) Telegraph.
 - (b) Telephone.
- (5) *Visual communication.*
 - (a) Lamps.
 - (b) Flags.
 - (c) Panels.
 - (d) Pyrotechnics.
 - (e) Airplanes.
- (6) *Sound communication.*
- (7) *Wire communication.*
 - (a) Telephone.
 - (b) Telegraph.
 - (c) Telegraph printer.
- (8) *Signal supply.*

b. Means.—The signal systems within the division generally employ the following means: wire, messenger, and radio communication. Pigeon, visual, and sound communication are used for special purposes. In units where wire and messenger communication are available, radio com-

munication should be considered as an emergency means. However, it is unwise to rely upon any one means to the exclusion of others, because special circumstances may render that preferred means inoperative at a time when signal communication is urgently needed. It is for this reason that signal and communication units are organized to permit the simultaneous operation of several means which are appropriate to the special need of the unit.

■ 9. **TEAMWORK.**—To insure successful signal communication, the signal and communication troops must work as a team regardless of unit, arm, or service. There must exist a spirit of mutual helpfulness and cooperation. Personnel of adjacent units should take every suitable opportunity to become personally acquainted, to understand the special problems and conditions in neighboring units, and to offer such assistance and cooperation in the installation, operation, and maintenance of signal communication as may be practicable.

SECTION III

COMMAND AND STAFF DUTIES OF SIGNAL AND COMMUNICATION OFFICERS

■ 10. **RESPONSIBILITY FOR SIGNAL COMMUNICATION.**—*a. Commander.*—Responsibility for signal communication is a function of command. Each tactical commander is responsible for the installation, operation, and maintenance of all agencies of signal communication which form the signal system of his own unit. For purposes of coordination and technical control, he exercises supervision over the signal systems of all subordinate units of his command. For example, an infantry regimental commander is responsible for the installation, operation, and maintenance of his infantry regimental signal system and for supervision over the signal systems of his infantry battalions.

(1) The establishment and maintenance of signal communication between subordinate and superior units are the responsibility of the superior commander; between adjacent units, as directed by their common superior.

(2) A unit which supports another unit by fire is responsible for the establishment and maintenance of signal communication with the supported unit.

(3) In general, the responsibility for the establishment and maintenance of signal communication with an attached unit rests with the commander of the unit to which attached unless the attached unit is a fire supporting unit. (See (2) above.) For example, an artillery unit attached to a front line infantry or cavalry unit is responsible for the establishment and maintenance of signal communication with the command post of the unit to which attached.

b. Signal or communication officer.—In general, each tactical unit commander is provided with a special staff officer who is thoroughly trained in the tactics and technique of signal communication. He is charged, under the direction of the unit commander (or his G-3 or S-3), with the exercise of tactical and technical supervision of signal communication for the entire command. This special staff officer in the division headquarters is known as the signal officer. In subordinate units he is known as the communication officer.

c. Channels of supervision.—The tactical and technical supervision exercised by the signal or communication officer over signal communication of subordinate units is subject to the approval of his commander. The necessary supervision is exercised through the normal channels of command, except that technical supervision over routine matters may be exercised directly between the unit signal officers and communication officers concerned.

■ 11. STAFF AND COMMAND FUNCTIONS.—*a.* The signal or communication officer, as a member of the special staff group, assists the tactical commander in exercising his command functions relative to signal communication and acts as an adviser to the commander and other members of the staff on all matters relating to signal communication. Under instructions received from his commander, he acts as inspector and coordinator of the training and operations of subordinate signal or communication units.

b. The signal officer commands, insofar as relates to training and tactical employment, all signal troops assigned to

serve his headquarters. As a commander of troops, the signal officer is responsible for the proper training and tactical employment of his own signal unit.

c. These two functions of staff and command, although vested in the same individual, are separate and distinct in that each involves different responsibilities and duties and the exercise of one should not be confused or permitted to interfere with the exercise of the other. However, this dual function of the signal officer has many advantages in facilitating the proper discharge of both his command and staff duties.

■ 12. DETAILED DUTIES.—*a. Signal officer.*—(1) *During mobilization.*—During mobilization the signal officer—

(a) Prepares requisitions for personnel to bring his unit to authorized strength as prescribed by Tables of Organization.

(b) Inventories and inspects signal equipment, and requisitions that which is necessary to bring the quantity on hand up to that authorized by Tables of Basic Allowances for his unit and for subordinate units.

(c) Prepares the training programs for signal communication troops of his unit and lower units under the general policy laid down by his commander and by higher authority, adapting it to meet local conditions and the time period allowed for mobilization.

(d) Takes steps to secure and supply authorized training equipment throughout the command.

(e) Organizes and supervises such troop schools for communication specialists as may be authorized by his commander or required by orders of higher authority.

(f) Prepares for the approval of the commander such routine orders and signal operation instructions as may be needed for the efficient training of the signal and communication personnel of the command.

(g) Personally supervises the training of and secures the training and organization equipment for the signal troops of his unit.

(h) Recommends training for the signal units with the staffs and the troops.

(2) *During actual or simulated combat.*—During actual or simulated combat the signal officer—

(a) Prepares or secures from higher authority such orders and signal operation instructions as may be needed to insure tactical and technical control of the signal system of his unit. Insures the proper distribution of such orders and signal operation instructions throughout his unit.

(b) Recommends the initial location of the command post of his own unit, if this location has not been prescribed by higher authority. Recommends the initial locations for the command posts of the next subordinate units when practicable. When the necessity for the displacement of command posts during the operation can be foreseen, recommends the axes of signal communication for the next subordinate units and for his own unit, when it has not been prescribed by higher authority. Submits these recommendations to the commander or to a designated staff officer, on most staffs to the G-3.

(c) Prepares plans for the employment of the signal agencies of his own and subordinate units so as to insure the most efficient employment of these agencies within his own headquarters and the necessary coordination and technical control of the agencies of subordinate units, subject to orders received from higher authority. Submits these plans to his commander or to the appropriate staff officer for approval.

(d) Prepares all signal orders based upon the approved plan of signal communication, transmits these orders to the proper issuing agency, checks on the issue of these orders, and supervises their execution.

(e) Establishes and operates the signal system for which his unit commander is directly responsible; supervises the signal systems employed by subordinate units to discover deficiencies; orders or recommends corrective action, and thus secures coordination between systems during combat.

(f) Takes steps to procure and supervise the replacement of signal equipment and personnel of his own and subordinate units.

b. Communication officer.—The communication officer performs duties similar to those for a signal officer with respect to the signal communication troops of his own and subordinate units when such duties are appropriate.

CHAPTER 2

THE MESSAGE CENTER

	Paragraphs
SECTION I. General	13-24
II. Procedure for divisions and higher units.....	25-30
III. Procedure in headquarters below the division..	31-36
IV. Related procedures.....	37-42
V. Military cryptography.....	43-49
VI. Description and use of cipher device M-94.....	50-57

SECTION I

GENERAL

■ 13. DEFINITIONS.—*a. Message center.*—The message center is the agency of the commander at each headquarters or command post charged with the receipt, transmission, and delivery of all messages except those indicated in paragraphs 16*d* and 35*b*(1)(*c*).

b. Addressee.—An addressee is the person or office to which a message is to be delivered. The term includes a representative authorized by an addressee to receive his messages.

c. Message.—See paragraph 5*a*.

d. Writer.—The originator of a message is called the writer.

e. Code.—Except as indicated in section V and in paragraph 100, the word "code" and its derivatives is used in this manual as a general term to include also cipher and its derivatives.

■ 14. PURPOSE.—*a.* The sole purpose of the message center is to speed the transmission of messages. It seeks to accomplish this purpose by—

(1) Providing a designated point to which messages and messengers may be directed.

(2) Keeping informed of the current effectiveness of each available means of signal communication.

(3) Properly distributing message traffic to the available effective means of signal communication.

(4) Eliminating unnecessary delays in transmission.

(5) Operating an efficient messenger service.

b. The message centers of division and higher units are operated by signal units. Message centers of subordinate units are operated by communication units. Message centers are located at the command post and at the rear echelon of the headquarters of large units. Advance message centers for the reception and relay of messages are employed as a part of the signal system to facilitate signal communication with advanced units or units operating on a flank.

c. Advance message centers are established when required to relay messages transmitted by different means of signal communication or through different channels of the same means. Information of their locations is always transmitted to the troops. Advance message centers are frequently employed as a part of the signal system to facilitate the transmission of information and reports from front line reconnaissance and security units. They are also employed frequently in the reconnaissance operations of cavalry divisions as collecting points for messages from several reconnaissance detachments.

d. The message center is not organized or equipped to perform stenographic or clerical work pertaining to the headquarters which it serves. It is not equipped to prepare copies of outgoing messages for multiple transmission, nor to prepare additional copies of incoming messages for multiple distribution. It will therefore not be used for these purposes. (See par. 21.)

■ 15. CLASSIFICATION OF MESSAGES.—Messages are classified according to—

a. *Intelligibility of their language as clear or code messages* (sec. V).—(1) A clear message is one in which the text of the message conveys an intelligible meaning in a spoken language.

(2) A code message is one in which the text of the message conveys no intelligible meaning in any spoken language.

b. Procedure used when transmitting electrically.—This classification refers to the procedure employed in transmission of the message and in no way to the writing of the message by the writer.

(1) *Normal form.*—The normal form message is ordinarily used when transmitting messages electrically between divisions or higher headquarters. The abbreviated form may be used if desired. (See par. 37b.)

(2) *Abbreviated form.*—The abbreviated form message is always used when transmitting messages by radio within the division and between elements of the division and smaller units. For messages sent by means other than radio the normal form may be used if desired. (See par. 37c.)

c. Urgency with which handled.—Messages may be classified as urgent or priority by the writer. Messages transmitted electrically in the normal form may carry any of the four classifications given below as to urgency. Messages transmitted in the abbreviated form will carry either the urgent classification or no classification at all. In the latter case they will be handled as routine messages.

(1) *Urgent (O).*—Commanders must restrict the use of the urgent classification to the most urgent messages; excessive use will defeat its purpose. Urgent classification indicated by symbol O is reserved for messages requiring the greatest speed in handling. It is used only in combat or when real or simulated combat is imminent to indicate that the message conveys most urgent orders, information, or requests pertaining to combat. It may also be used when reporting serious damage or distress during peace or war. Urgent messages will be sent immediately upon receipt, except when communication involving another urgent message is being carried on.

(2) *Priority (P).*—Priority classification, indicated by the symbol P, is used for messages of less urgency than those entitled to urgent classification but which warrant precedence over routine messages in order to reach the addressee in time for effective action. Priority messages will be transmitted before such routine messages as may be waiting to be sent, but transmission of a message will usually not be interrupted to send a priority message.

(3) *Routine* (no symbol).—Routine classification is used for messages which require no special precedence. The majority of the messages handled by the message center will be routine messages. They are transmitted in the order in which they are received.

(4) *Deferred* (NITE).—The deferred classification indicated by the term NITE is used for those messages whose delivery to the addressee may be delayed until the beginning of office hours of the morning following the day on which they are filed. (See JANP.)

d. Terminology employed in message center operation.—

(1) *Outgoing messages.*—Outgoing messages are those coming to the message center from local sources for transmission to an office or individual served by another message center. Under this same heading fall those messages for individuals of the headquarters or echelon served by the message center and for those units not served by a message center which are located beyond the normal operating distance of local messengers or at a considerable distance from the message center.

(2) *Incoming messages.*—Incoming messages are those coming to the message center from an office or individual not served by the message center for delivery within the headquarters or echelon so served. Under this heading fall those messages received from a distant member of the headquarters or echelon so served who is located beyond the normal operating distance of local messengers.

(3) *Relay messages.*—Relay messages are those originating outside the headquarters or echelon served and sent to the message center for delivery to an office or individual at another headquarters or echelon.

(4) *Local messages.*—Local messages are those originating at an echelon of a headquarters for delivery to another office or individual at the same echelon. Such messages are not handled by the message center.

e. Secrecy.—Messages are classified as secret by the writer if their content so warrants. In simulated or actual tactical operations, all messages not classified as secret will be regarded as confidential and need not be so marked. (See AR 380-5.)

■ 16. RESPONSIBILITY.—*a. Outgoing messages.*—The responsibility of a message center begins when a message is received by the message center and continues until the message is received for by the addressee, another message center, or a means of signal communication at another headquarters or echelon.

b. Incoming messages.—The responsibility of a message center begins with the receipt of the message by whatever means of signal communication employed and continues until received for by the addressee.

c. Relay messages.—The responsibility of the relaying message center begins with the receipt of the message by whatever means of signal communication employed and continues until received for by the addressee, another message center, or a means of signal communication at another headquarters or echelon.

d. Other messages.—The message center is not responsible for those messages which are—

- (1) Transmitted directly by the writer to the addressee by telephone or personal agency.
- (2) Handled by the military or civil postal service.
- (3) Local messages. (See par. 15*d* (4).)

■ 17. FLEXIBILITY OF ORGANIZATION.—*a.* Since the handling of messages is an important function of command, the commander of each unit is responsible for the adoption of methods which are satisfactory for his unit. Message centers will operate with a varied number of men depending upon the size of the unit, the magnitude of operations, the time of day, and all other factors which affect the volume of traffic to be expected during any given period. *Flexibility in procedure and organization is therefore desirable and authorized.*

b. Situations peculiar to a particular headquarters organization or tactical operation may require special methods of procedure. Commanders will be alert to recognize such situations and to adapt their methods to secure best results. A standard procedure is desirable but it will not be considered binding when departures therefrom will speed operation. In adopting other methods, however, it should be borne in mind

that each message center must transact business with other message centers. This will require a certain amount of uniformity of procedure to prevent confusion. It should also be borne in mind that personnel allotted the message center is sufficient to handle only the minimum functions incident to the handling of normal message traffic, and that if operations in excess of these minimum functions are required, the necessary additional men must be provided by the commander.

c. The methods of handling messages as set forth in this chapter are intended to illustrate only two of several methods which may be employed successfully. Deviations therefrom are authorized if circumstances warrant.

■ 18. TRAINING.—*a. Objective.*—The time required for all clerical operations of the message center, including time recording and numbering of the message, enclosing and preparation of the envelope if used, or preparation of a delivery list should not exceed 20 seconds.

b. Maximum delay time in message centers.—No message will be delayed in the message center on account of recording operations longer than two minutes, exclusive of the time required for coding or decoding. Commanders are responsible that sufficient personnel are available and properly trained to accomplish this objective. If the volume of business at any time exceeds the capacity of the message center personnel to perform the normal recording operations within this maximum delay time, the unit commander will be promptly informed and additional personnel provided or the normal operations abridged or eliminated.

c. Personnel.—For detailed instructions as to training of messengers, see section II, chapter 3. The training of message center and messenger personnel will emphasize—

(1) Military courtesy, with special reference to expressions used in accepting and in delivering messages.

(2) Staff organization, particularly the organization and personnel at local headquarters.

(3) Organization of the unit and the numerical designations of subordinate and superior units.

d. Conference with users of the system.—It must be realized that commanders and staff officers do not always find

time to keep up with regulations relating to use of the signal system. It will prove helpful to the entire unit if the signal or communication officer finds opportunity in a staff conference or otherwise to explain to the principal users of the system such matters as—

(1) Handling of urgent, priority, routine, and deferred messages and how the excessive use of urgent and priority classifications will defeat the purpose for which they are established.

(2) Handling secret and other messages.

(3) Value of writer's identification number in case future reference to the message is anticipated between writer and addressee.

(4) Schedules of messenger service, with the suggestion that when practicable outgoing messages be submitted to meet these schedules.

(5) Advantage of the telegraph or telegraph printer over the telephone for certain types of messages.

(6) Policy of the commander regarding the transmission of radio messages in the clear. See paragraph 43 for basic policy in this respect.

(7) Necessity for warning the message center of any unusual demand for service which will be made upon it, such as the distribution of field orders at a certain hour.

(8) Desirability for the writer to submit all messages in duplicate.

(9) Directions for submission of messages for multiple distribution.

(10) Any other matters which require coordination.

■ 19. INFORMAL CONTACT WITH NEIGHBORING MESSAGE CENTERS.—Effective operation is facilitated by informal contact between neighboring message centers on matters of mutual interest. Such matters include reporting the delivery of an important message, notifying the other message center of the reason for delay in securing an answer, warning the neighboring message center that it will shortly receive orders or other messages which will require special measures for prompt handling, etc. Neighboring message centers should thus work together as a team; each should assist the other in meeting mutual problems and in answering likely

inquiries. Each message center should welcome such assistance from its neighbors.

■ 20. PRINCIPLES OF OPERATION.—*a. Continuous service.*—During active operations, message center service is continuous and is effected as follows:

(1) *On the march.*—Message centers may function during the march to afford communication between columns, within the column, and with aerial or ground reconnaissance troops.

(2) *Message center at each echelon.*—A message center is established at each echelon of the headquarters. (See par. 14b.) When an echelon moves, the message center opens at the new location prior to or at the same time as the closing of the message center at the former location.

b. Message center location.—(1) The message center and the routes leading thereto should be well marked with appropriate signs.

(2) On the march, the position of the message center in column is made known to all concerned by designating its position in the march order and by the use of pennants and panels; the latter to mark the location from the air in order that messages may be dropped in the immediate vicinity by aircraft.

(3) The following are desirable physical features of the message center:

(a) Quiet.

(b) Protection from rain and wind.

(c) Capability of being made lightproof at night and gasproof at any time.

(d) Accommodations for messengers, telephone stations, and at large headquarters for telegraph, telegraph printer, and radio stations as close as practicable to it.

(e) Convenience to staff sections and to incoming messengers.

c. Employment of means of signal communication.—In coordinating the use of the various means of signal communication, the message center employs the most suitable and rapid means available for the transmission of any message. To this end the message center will keep itself in-

formed as to the availability of all means. The considerations governing the means to be employed are:

(1) Messages to go only a very short distance should habitually be sent by messenger.

(2) Maps, documents, photographs, and similar messages must be sent by messenger unless equipment for facsimile transmission is available.

(3) Short messages going a comparatively long distance should be sent by some electrical means.

(4) Whenever possible, the telegraph or telegraph printer should be used in preference to the telephone in order that the latter may be kept open for direct communication by the commander and his staff.

(5) Messages should be sent by pigeon only in case of the failure of all other means of signal communication. The instructions in paragraph 43 as to encoding radio messages apply to pigeon messages also.

(6) Very long messages should usually be sent by messenger.

(7) Messages transmitted by radio are subject to interception by an alert enemy. It therefore becomes essential to encode all such messages as directed in paragraph 43. Because of the delays incident to encoding and decoding and because of possible interception, radio should be used only when it is the sole means available or is clearly the most suitable means.

(8) If the importance of the message so warrants, it may be sent by two or more means subject to the restrictions imposed by cryptographic security. (See AR 380-5.)

(9) Urgent and priority messages are sent by the most rapid means available. (See par. 15c.)

(10) Routine administrative reports must be transmitted by means other than radio.

d. Forms and equipment.—Certain blank forms, stamps, and other equipment are normally provided for convenience and to save labor. *Message center operation will however not be made dependent upon blank forms or other equipment, nor will the absence of such material be permitted to delay messages in the message center.*

■ 21. **MULTIPLE DISTRIBUTION.**—When distribution of mimeographed or printed material to a number of addressees is desired, all copies required for each addressee will be delivered to the message center wrapped, packaged, or otherwise secured, and plainly marked with its destination. Each such package, envelope, or container will be handled by the message center as a single message and will be delivered by messenger. One additional copy of the message should be delivered to the message center.

■ 22. **MESSENGER SYSTEM.**—For the employment of messengers, see chapter 3.

a. *Estimate of needs.*—Since all local delivery and a large portion of message traffic between message centers is handled by messenger, an effective messenger system is indispensable. It is therefore an important responsibility of the commander to provide adequate personnel to meet the expected needs for messengers and to provide for their means of transport. The message center should be required to submit estimates of messenger requirements supported by proposed schedules of hours, routes, and distances. These estimates should show the necessity for the detail of sufficient and suitable men.

b. *Casualties.*—War experience has shown that messengers suffer heavy casualties and that when these casualties are not promptly replaced or when insufficient men are detailed to the messenger service, the messenger personnel is soon brought to the limit of physical endurance. The unit commander should therefore keep himself informed of the messenger situation and should be prepared to detail additional trained messengers whenever they are required.

c. *Messenger dispatcher.*—The messenger dispatcher should be selected with care. He should be a forceful noncommissioned officer and able to write rapidly; he should be mentally alert and have considerable endurance; and above all, he should know how to handle his messengers with the proper combination of understanding and firmness.

d. *Organization.*—It may be expected that the number of messengers detailed will be the minimum estimated even under the most favorable circumstances. It is vitally important therefore that this personnel be carefully selected and well trained and that its transport be utilized at maxi-

imum efficiency. As the requirements for messengers change from day to day and even from hour to hour, the organization must be flexible. This flexibility is enhanced if the sleeping quarters of the messengers are in the immediate vicinity of the message center. When practicable, messengers should be organized into shifts and details to provide 24-hour service for—

- (1) Local delivery.
- (2) Scheduled messenger service to other message centers.
- (3) Special messengers to handle urgent and priority messages and other special missions.

■ 23. CHARTS, MAPS, AND DIAGRAMS.—The items given below, particularly in divisions and higher headquarters, are sometimes found helpful in conducting the operations of the message center. In order to be of value, it is essential that any of the items used be kept up to date.

a. A display map to show the locations of headquarters of the next superior and of the next subordinate units, the scheduled messenger routes, and other information which would be useful to messengers.

b. A corresponding diagram of the locations of the several offices at the local headquarters, possibly showing the names of the principal occupants of those offices.

c. A ready reference chart showing the various means of signal communication established to the different units prepared in substantially the following form and with pins placed in appropriate spaces to indicate the means which are established. (See par. 34a.)

Unit	Messenger	Telegraph	Telephone	Radio
16 Inf.....				
18 Inf.....				
26 Inf.....				
7 FA.....				

d. A list of officers on duty with the unit.

e. A duty chart of message center and messenger personnel.

■ 24. ABBREVIATIONS.—In indicating the means by which messages may be transmitted, the following abbreviations are used:

Msg	—Message
Msg Cen	—Message center
Msgr	—Dismounted messenger (runner)
Ap Msgr	—Airplane messenger
Bcl Msgr	—Bicycle messenger
M Msgr	—Motor messenger
Mtcl Msgr	—Motorcycle messenger
Mtd Msgr	—Mounted messenger
Scd Msgr	—Scheduled messenger
Sp Msgr	—Special messenger
Pgn	—Pigeon
Rad	—Radio
Tg	—Telegraph
Tgp	—Telegraph printer
Tp	—Telephone
Vis	—Visual

SECTION II

PROCEDURE FOR DIVISIONS AND HIGHER UNITS

■ 25. ORGANIZATION.—*a.* In describing the procedure for divisions and higher units, duties are outlined for message center chief, messenger dispatcher, code clerk, messengers, and operators of the several means of signal communication. This division of duties is functional and is made for convenience in description. In small message centers during periods of inactivity, one man may perform two or more functions while in large and busy message centers two or more men may be required for a single function.

b. The term "message center chief" is applied to the senior specialist on duty.

c. The term "operator" includes telegraph, telegraph printer, and radio operators.

■ 26. EQUIPMENT AND FORMS.—There is no guarantee that all messages arriving at a message center for transmission will be on standard forms and properly prepared. Nevertheless, the

responsibility of the message center begins when the message is presented to it by the writer, regardless of the manner or form of presentation, and every effort will be made to insure its rapid and accurate transmission to the addressee. The following equipment and forms are helpful though the procedure may be used without them:

a. Received stamp.—The received stamp indicates in permanent type the message center designation; in movable type the month, date, and year and also provides for time entry by clock operated stamp.

b. Serial number stamp.—This is an automatic numbering stamp.

c. Field message book.—This book, 4¾ by 6 inches in size, contains message blanks for all messages and special tissue blanks for pigeon messages.

d. Message blank, US Army.—This blank is about 8 by 8 inches in size and is blank except for its heading and the direction, "Submit message to message center in duplicate." This blank is suitable for messages of usual length and is convenient for typing and filing. If the form is not available or if the message is unusually long, any other type or size of paper may be used.

e. Number sheet.—The following is an extract from W. D., S. C. Form No. 159. The complete form provides spaces for 100 messages. (See par. 34a.)

WAR DEPARTMENT

SIGNAL CORPS, U. S. ARMY

NUMBER SHEET

				(Unit)		(Date)	
No.	REMARKS	No.	REMARKS	No.	REMARKS	No.	REMARKS
1	-----	26	-----	51	-----	76	-----
2	-----	27	-----	52	-----	77	-----

SIGNAL COMMUNICATION

f. Delivery lists.—(1) The following is an extract from W. D., S. C. Form No. 160. The complete form provides spaces for seven messages.

WAR DEPARTMENT
SIGNAL CORPS, U. S. ARMY
LOCAL DELIVERY LIST

TIME DISPATCHED	TIME RETURNED
MESSAGE NO.	SIGNATURE IN FULL

(2) The following is an extract from W. D., S. C. Form No. 158. The complete form provides spaces for 19 messages.

WAR DEPARTMENT
SIGNAL CORPS, U. S. ARMY
ROUTE DELIVERY LIST

TIME DISPATCHED	TIME RETURNED	
MESSAGE NO.	SIGNATURE IN FULL	TIME RECEIVED

(3) The above forms are used for securing receipts for messages delivered by messenger. The one in (1) above is most suitable for local messengers and the one in (2) above for scheduled messengers.

g. Skeleton copy stamp.—This is a rubber stamp with the word "SKELETON" in letters about 1 inch in height. This stamp is used in stamping message blanks when preparing skeleton copies. (See par. 27g.)

h. Paper fastening machine.—This is a medium duty, spool of wire type of machine.

i. Message carrying bags.—These are bags for the use of messengers.

■ 27. **HANDLING OUTGOING MESSAGES.**—The procedure prescribed in this paragraph and paragraph 28 applies specifically to messages unclassified as to secrecy which are treated as confidential. The procedure for handling secret messages differs somewhat and is described in paragraph 29. Outgoing messages coming to the message center from a local source may be handled by the separate specialists listed below in the manner described:

a. Message center chief.—The message center chief—

(1) Receives the message in duplicate from the writer, his representative, or a messenger.

(2) Immediately inspects the message for legibility and proper address. He declines to accept illegible and improperly addressed messages and, if necessary, brings such messages immediately to the attention of the message center officer.

(3) Writes the time of receipt on both copies of the message or stamps the time of receipt on the back of both copies with his received stamp.

(4) Writes or stamps the message center number with his serial number stamp beginning a new series at midnight each day.

(5) Checks the message center number off his number sheet by drawing a diagonal line through the corresponding number.

(6) (a) If he decides that the message should go forward by electrical means and transmission in the clear is normal or authorized by the commander, he delivers the original of the message at once to the operator and files the duplicate copy in the live file. (See par. 34b.)

(b) If the message is to be transmitted in code, by radio, or by other means, he passes the original of the message at once to the code clerk and files the duplicate copy in the live file. (See par. 20c (7).)

(c) If the message is to be sent in the clear by messenger, he passes the original of the message at once to the messenger dispatcher and files the duplicate copy in the live file.

(7) Receives the signed delivery list from the messenger dispatcher as soon as it has been returned by the messenger.

(8) Checks the transmitted messages off his number sheet during lulls in traffic handling by drawing a second opposing diagonal line through or encircling the corresponding number. Traffic will not be delayed to perform this operation.

(9) (a) Files the originals of electrically transmitted messages in the dead file when these are returned by the operator. These originals are used for reference. Removes the duplicate copies from the live file and destroys them. (See par. 34c.)

(b) Removes from the live file duplicate copies of messages sent by messenger and places them and the signed delivery lists in the dead file.

(10) Uses pigeonholes or envelopes for filing. For ready reference these are labeled with the name of the unit whose traffic they contain, for example, "From I Corps," "To I Corps," "From 1st Div." "To Army," etc. Files are kept for all units with which the message center does considerable business. A file marked "From Miscellaneous" and "To Miscellaneous" is kept for all other business.

b. *Operator*.—(1) Receives the original of the clear text message from the message center chief or the original encoded message from the code clerk.

(2) Transmits the message and receives a receipt from the distant operator.

(3) Services the message in his possession and when he no longer needs it for verification, returns it to the message center chief for file. (See a (9) (a) above.)

c. *Code clerk*.—(1) Receives the original of the message to be encoded from the message center chief.

(2) Encodes it without making a duplicate copy of the encoded message.

(3) Indicates pertinent data as to address, operating instructions, and urgency, if any, on the encoded message.

(4) Passes the encoded message either to the operator or, in case of messenger transmission, to the messenger dispatcher.

(5) Files the original of the clear text message in his file.

d. Messenger dispatcher (f below).—The messenger dispatcher, who is charged with the handling of messengers—

(1) Receives the original of a clear text message from the message center chief or a code message from the code clerk.

(2) Normally prepares one copy only of a delivery list for transmission by messenger. However, if there is danger of the messenger becoming a casualty or if an unreliable messenger must be employed, he prepares the delivery list in duplicate. A good carbon copy must be made in these cases and this copy is retained by the messenger dispatcher.

(3) Enters the message center number in the first column of the delivery list.

(4) Stamps or writes the time dispatched in the proper blank space of the delivery list just prior to the messenger's departure.

(5) Hands the message and delivery list to the messenger and gives him any instructions necessary.

(6) Stamps or writes the time returned in the proper blank space of the signed delivery list when it is returned by the messenger.

(7) Hands the completed delivery list to the message center chief.

e. Messenger (f below).—The scheduled or special messenger—

(1) Receives the message and delivery list from the messenger dispatcher and proceeds to the distant message center or to the addressee.

(2) Delivers the message and delivery list to the message center chief of the distant message center or to the addressee who signs it and, in the case of the route delivery list, enters the time of receipt in the last column.

(3) Receives the signed delivery list from the message center chief or addressee and either returns to his own message center or continues to other message centers or addressees on his route if he has additional deliveries to make.

(4) On his return, enters either his name, initials, or his messenger number as required by local regulations, on the delivery list for identification.

(5) Hands the delivery list to the messenger dispatcher of his own message center.

f. Scheduled messenger service.—(1) *Routine messages.*—For scheduled messenger service, the delivery list is handled as follows:

(a) When a scheduled messenger has just departed on a certain scheduled route and the next message for delivery on that route reaches the messenger dispatcher's desk, the latter enters the message center number in the first column of a delivery list. He enters succeeding messages for that route on successive lines as they arrive.

(b) When the time scheduled for the next messenger's departure arrives, the messenger dispatcher enters or stamps the time dispatched in the proper space, turns the delivery list and messages over to the messenger, and gives him such instructions as may be necessary.

(c) The messenger delivers the messages according to his standing instructions supplemented by such special directions as he may have received for the particular run. He secures a signature for each message.

(2) *Other messages.*—Delivery of urgent and priority messages will not be held up for a scheduled messenger.

g. Skeleton copy of message.—Some messages will be submitted to the message center without a duplicate copy. If such a message is to be transmitted by electrical means, the single copy is all that is required. But if it is to be transmitted by messenger, a skeleton copy is made for follow-up and this copy is thereafter handled as a duplicate copy. The skeleton copy is usually brief. For example, in case of a 100-word message relating to class I supplies, the skeleton copy might be simply, "QM to Army QM Class I supplies." In case of a bundle of maps it might be, "G-3 to G-3, 26 Div bundle maps." A very brief description is all that is required for identification. An urgent or priority message is not delayed for the preparation of a skeleton copy. If a skeleton copy is required, it is made as accurately as possible from memory after the message has been dispatched and the notation **FROM MEMORY** is added.

■ 28. **HANDLING INCOMING MESSAGES.**—Messages received at a message center for delivery to local addressees may be handled in the manner indicated below. Incoming messages are not assigned message center numbers.

a. Operator.—(1) Copies the message in duplicate.

(2) Services the message, entering time received under the message.

(3) If the message is in the clear, passes or delivers—

(a) Original to the messenger dispatcher for delivery to the addressee.

(b) Duplicate copy to the message center chief when no longer needed for verification.

(4) If the message is in code, passes or delivers—

(a) Original of the message to the code clerk.

(b) Duplicate copy of the message to the message center chief when no longer needed for verification.

b. Message center chief.—(1) Receives and files the duplicate copies from operators referred to in *a* above.

(2) Receives the message from an incoming messenger, signs the delivery list of the distant message center, returns the delivery list to the messenger, and stamps the message or its cover with his received stamp; hands the message directly to the messenger dispatcher or to the code clerk if in code; after the message has been delivered, receives the completed local delivery list from the messenger dispatcher and files it in the dead file.

c. Code clerk.—(1) Receives the original of the code message from the operator or from the message center chief if received by messenger.

(2) Decodes the message, making an original only.

(3) Enters the operator's heading on the decoded message.

(4) Passes the message to the messenger dispatcher, files the original of the code message in his file for reference, and disposes of this file as directed by the unit signal or communication officer.

d. Messenger dispatcher.—The messenger dispatcher receives an original of a clear text message directly from the operator, a decoded message from the code clerk, or a message transmitted by messenger from the message center chief, and—

(1) Prepares a delivery list.

(2) Designates a messenger to deliver the message.

(3) Stamps or writes the time dispatched in the proper space when the messenger is ready to depart.

(4) Hands the message and delivery list to the messenger.

(5) Stamps or writes the time returned in the proper space when the signed delivery list has been returned to him by the messenger.

(6) Hands the completed delivery list to the message center chief.

(7) In handling urgent and priority messages and in order to avoid delay in delivery, the messenger may be given a blank delivery list and be instructed to request the addressee to fill in the message number as well as the signature, and in case of the route delivery list, the time of receipt.

e. Messenger.—(1) Receives the message and the delivery list from the messenger dispatcher.

(2) Delivers the message and the delivery list to the addressee and obtains his signature, and in the case of the route delivery list, the time received.

(3) Returns to the message center and enters his name, initials, or his messenger number as required by local regulations, on the delivery list for identification.

(4) Hands the delivery list to the messenger dispatcher.

■ 29. **HANDLING SECRET MESSAGES.**—The handling of secret messages is prescribed in detail in AR 380-5. The procedure for handling secret messages in the message center differs from the handling of nonsecret messages in the respects mentioned below. In tactical operations when time permits, secret messages will normally be carried by a staff officer or special messenger operating as a direct agent of the transmitting office. They may be transmitted by electrical or other means available to the message center when the time of transmission can be reduced thereby.

a. Outgoing messages.—The writer of an outgoing message submits to the message center only a *single* copy of a secret message. The message center chief stamps this message with his time stamp and serial number stamp, makes the notation "Secret" in the REMARKS column of his number sheet, and passes the message to the code clerk. The code clerk makes an original and one duplicate copy of the coded message, these copies being henceforth handled in the same manner as nonsecret messages. The original of the plain

test message is then marked, "Sent in secret code" and is returned to the writer. The original of the coded message is passed to the transmitting agency and the duplicate code copy is kept in the live file and final disposition made in the same manner as for duplicate copies of nonsecret messages.

b. Incoming messages.—An incoming secret message is handled like a nonsecret message except that the single copy secret code."

of the plain text is marked by the code clerk, "Received in

■ 30. HANDLING RELAY MESSAGES.—*a.* The operator hands or sends both the original and the duplicate copy to the message center chief whether received in code or in clear. In case the message is received from a messenger, only the original is available.

b. The message is then handled as an outgoing message. It is not given a message number by the relaying message center.

c. A message received in code is not decoded by the relaying message center.

d. A copy of the message will be available in the message center with the operator's service for follow-up if received or transmitted by electrical means.

e. No copy of the message will be available in the message center if received and transmitted by messenger. In this case, the signed delivery list or message envelope is the only record. If considered necessary, a skeleton copy may be made for reference.

SECTION III

PROCEDURE IN HEADQUARTERS BELOW THE DIVISION

■ 31. GENERAL.—Simplicity and speed in handling message traffic are paramount considerations. If necessary to meet local requirements, unit commanders are authorized to make modifications in the procedure given in paragraph 35.

■ 32. ORGANIZATION.—*a.* In describing the procedure, duties are outlined for message center chief, messenger dispatcher, code clerk, messenger, and operators of the several means of signal communication. This division of duties is func-

tional and is made for convenience in description. For definitions of the terms "message center chief" and "operator" see paragraph 25. For the classification of messages, see paragraph 15.

b. In small message centers during slack periods, one man may perform all the duties at the message center. For this reason each member of the message center team must be trained to perform all the duties incident to message center operation. The message center personnel should be able to operate as two teams in order to provide for continuous operation when the command post is moved.

c. If shortage of personnel requires it, the duties of the code clerk may be delegated to the radio section. (See par. 43.)

■ 33. FORMS AND EQUIPMENT.—Message center procedure is not dependent on forms. No equipment other than pencil, paper, and the authorized codes and cipher devices is required. Certain forms such as delivery lists, number sheets, field message books, and message envelopes are, however, usually provided for convenience and to save labor. (See par. 26.)

■ 34. RECORDS.—The message center keeps only such temporary records as are required to insure rapid and accurate handling of message traffic. The following records are usually kept:

a. *Number sheet.*—Message center numbers are assigned to each outgoing message. (See par. 27a (4).) If desirable, the chart referred to in paragraph 23c and the number sheet referred to in paragraph 26e may be combined into a message center log. An example of an extract of such a log is shown below. Spaces for 100 numbers and additional units may be conveniently provided on the form. If it is used, the instructions in this chapter dealing with the number sheet apply also to this form.

SIGNAL COMMUNICATION

34

MESSAGE CENTER LOG

1st FA

5-4-39

(Unit)

(Date)

RECORD OF SERVICEABILITY OF AGENCIES							No.	RE-MARKS	No.	RE-MARKS
UNITS TO WHICH CONNECTED	RAD		TG		TP					
	In	Out	In	Out	In	Out				
4th F. A. Brig	645A	705A	715A	830A	705A	830A	1	Rad	51	
	830A	845A	845A	930A	845A	930A	2	Ty	52	
	930A	1000A	1000A	-----	1000A	-----	3	Mmgr	53	
	-----	-----	-----	-----	-----	-----	4		54	
	-----	-----	-----	-----	-----	-----	5		55	
	-----	-----	-----	-----	-----	-----	6		56	
	-----	-----	-----	-----	-----	-----	7		57	
	-----	-----	-----	-----	-----	-----	8		58	
	-----	-----	-----	-----	-----	-----	9		59	
	-----	-----	-----	-----	-----	-----	10		60	
1st Bn 1st F. A.	700A	705A	715A	800A	705A	800A	11		61	
	800A	815A	815A	900A	815A	900A	12		62	
	900A	910A	910A	-----	910A	-----	13		63	
	-----	-----	-----	-----	-----	-----	14		64	
	-----	-----	-----	-----	-----	-----	15		65	
	-----	-----	-----	-----	-----	-----	16		66	

b. Live file.—The live file consists of a duplicate or skeleton copy of each outgoing message which has been sent to a signal agency for transmission but for which a receipt has not yet been obtained.

c. Dead file.—The dead file consists of the duplicate or skeleton copies of all receipted outgoing messages; receipted delivery lists or message envelopes; and the receipted duplicate clear text copies of all incoming messages received in code by means other than messenger. The dead file is disposed of daily or oftener as directed by the unit communication officer. Unless otherwise directed by the commander, it is turned over to S-1 at frequent intervals so that messages may be included in the unit journal.

d. Code clerk's file.—This file contains the original clear copy of all outgoing messages sent in code and the original copies of all incoming code messages. CAUTION: *Clear and code copies of the same message must never be filed together.*

The file is disposed of daily as directed by the unit communication officer.

■ 35. **HANDLING MESSAGES** (par. 17c).—The following procedure may be used in handling messages at a message center. The procedure indicated is intended to illustrate only one of several methods which may be employed successfully.

a. Outgoing messages.—(1) *Message center chief.*—(a) Receives the message in duplicate from the writer or makes a skeleton copy in case only one copy is received.

(b) Enters on both the original and duplicate copies of the message in the proper spaces at the top of the field message blank, or in any convenient place if the regular message form is not used, the following:

1. *Time filed.*—The time the message was filed at the message center.
2. *Message center number.*—The next unassigned message center number.
3. *How sent.*—The means of signal communication selected for transmission. (See par. 24.)

(c) Checks off the number assigned the message by drawing a diagonal line through the number on the number sheet.

(d) Notes briefly, opposite the number assigned to the message on the number sheet, such data pertaining to the message as he considers necessary for reference.

(e) Hands or sends the original of the message to the operator, messenger dispatcher, or code clerk if it is to be encoded.

(f) Places the duplicate copy of the message in the live file.

(g) Services the duplicate copy of the message when notified by the transmitting operator of the time of receipt by the distant operator; or, in case the message was sent by messenger, on the return of the signed delivery list or message envelope. This servicing may consist of entering on the face of the message the date, time of receipt, and the personal sign of the message center chief, all inclosed in a circle.

(h) Places the serviced duplicate copy in the dead file to-

gether with the signed delivery list or message envelope if used.

(i) Indicates on the number sheet that receipt for the message has been obtained. This may be done by drawing an opposing, diagonal line through or encircling the assigned number on the number sheet.

(2) *Code clerk.*—(a) Receives the original of the message from the message center chief.

(b) Prepares one encoded copy of the message for transmission and enters on the top of the message such data as appropriate and required by the means to be employed. This will include the destination of the message, indicated by either the unit designation of the addressee or the call sign of the unit; operating instructions, if any; and the urgency of the message, if indicated by the writer. If the message is to be transmitted by messenger, the official designation of the addressee and writer must be shown in clear either on the message itself or on the message envelope if used.

(c) Hands or sends the completed code message to the transmitting agency. If going by messenger, he hands it to the messenger dispatcher, if there is one, otherwise he hands it to the message center chief.

(d) Files the original clear copy of the message.

(e) Destroys all work sheets by burning.

(3) *Messenger dispatcher.*—(a) Receives the original of the message from the message center chief or the code message from the code clerk.

(b) Prepares one copy of a delivery list or message envelope and enters the time dispatched.

(c) Hands the message and delivery list, or the enveloped message, to the messenger and gives him such special instructions as may be necessary. If the message is to be sent by pigeon, he places it in the message holder, releases the bird, and notifies the message center chief of the time of release. If the message is to be sent by the airplane pick-up method, he sends the message to the panel station. The message center chief is notified of the time of pick-up.

(d) Receives the signed delivery list or message envelope from the messenger on his return.

(e) Enters the time returned and hands the signed delivery list or message envelope to the message center chief.

(4) *Operator.*—(a) Receives the message from the code clerk, if encoded, or the message center chief, if it is to be sent in clear.

(b) Transmits the message.

(c) Services the message after acknowledgement of receipt by the distant operator.

(d) Notifies the message center chief without delay when the message has been transmitted and informs him of the time of receipt by the distant operator.

(e) Retains the transmitted copy of the message in his file for verification. The file is disposed of as directed by the unit communication officer.

b. Incoming messages.—(1) *General.*—(a) Incoming messages are not assigned message center numbers.

(b) Operators and the code clerk, in the case of code messages, are responsible for local delivery. Local delivery lists are not used, receipt being obtained on the duplicate copy of the message as received or as decoded.

(c) Incoming special messengers deliver their messages to addressees, obtaining receipt on their delivery list or on the message envelope. No action is taken by the personnel of the local message center other than to direct the incoming messenger to the location of the addressee.

(d) Incoming scheduled messengers deliver their messages to the message center chief who signs for them and effects delivery by local messenger. Obtaining local receipts is optional. The message center chief hands code messages to the code clerk; the latter, after decoding, delivers the message to the addressee.

(2) *Operator.*—(a) Copies and services the message in duplicate.

(b) If the message is received in the clear, delivers both the original and the duplicate copy to the addressee and obtains a receipt on the duplicate copy. The receipted duplicate copy is handed to the message center chief when no longer needed for verification.

(c) If the message is received in code, hands or sends the original to the code clerk and retains the duplicate copy in his file for verification.

(3) *Code clerk.*—(a) Receives the original of the code message from the operator or the message center chief, if received by messenger.

(b) Decodes the message making an original and duplicate clear copy.

(c) Delivers the original and duplicate clear copy directly to the addressee and obtains a receipt on the duplicate copy.

(d) Gives the receipted duplicate copy to the message center chief.

(e) Files the original of the code message in his file for verification.

(f) Destroys all work sheets by burning.

(4) *Message center chief.*—(a) Keeps informed as to the locations of offices and individuals served by his message center.

(b) Directs incoming special messengers to the person or office sought.

(c) Signs for incoming messages received from scheduled messengers and arranges for their local delivery. In case a message is received in code, he hands the code message to the code clerk.

(d) Arranges for local delivery by messenger in situations where it is not practicable or convenient for operators or the code clerk to deliver incoming messages directly to the addressee.

(e) Files the signed duplicate copies of the messages he receives from the operators and code clerk in the dead file.

c. *Relay messages.*—(1) The receiving agency hands or sends both the original and the duplicate copy to the message center chief whether received in code or in clear. In case the message is received from a messenger, only the original is available.

(2) The message is then handled as an outgoing message (a above) except that it is not given a message center number. The **TIME FILED** and **HOW SENT** items at the top of the message form are filled in under any corresponding entries which may be already there.

(3) A message received in code is not decoded by the relaying message center.

(4) A copy of the message will be available in the message center with the operator's service for follow up if received or transmitted by electrical means.

(5) No copy of the message will be available in the message center if received and transmitted by messenger. In this case, the signed delivery list, or message envelope, is the record. If considered necessary, a skeleton copy may be made for reference.

■ **36. MESSENGER SERVICE.**—*a. Scheduled.*—(1) Scheduled messenger service is established only when the locations of command posts, establishments, etc., are fixed for a sufficient length of time to warrant its employment.

(2) Scheduled messengers always deliver their messages to the message center of the addressee. Receipt for messages is obtained on a delivery list.

(3) The signed delivery list is returned by the scheduled messenger to his own messenger dispatcher or message center chief.

b. Special.—(1) Special messengers should always be available. They are dispatched as needed.

(2) Special messengers dispatched to the headquarters of divisions or higher units deliver their messages to the message center of the unit concerned.

(3) Special messengers arriving at headquarters below the division deliver their messages direct to the addressee. If necessary, information as to the location of offices is secured from the local message center.

(4) The signed delivery list or message envelope is returned by the special messenger to his own messenger dispatcher or message center chief.

c. Local.—In certain situations it may not be practicable, particularly in higher units due to dispersion of command post installations and other factors, for the message center chief or the code clerk to hand messages direct to the transmitting agency or for operators or the code clerk to deliver their incoming messages direct to the addressee. In such cases, local messengers must be available to provide for local deliveries within the command post.

SECTION IV

RELATED PROCEDURES

■ 37. ELECTRICAL TRANSMISSION OF MESSAGES.—*a. General.*—

(1) It is important that message center personnel have sufficient knowledge of radio and telegraph procedure to enable them to prepare messages properly for transmission and delivery when electrical means are used; *b* and *c* below are based upon the current Joint Army and Navy Radiotelegraph and Radiotelephone Procedure.

(2) The telephone is not considered a satisfactory means for a message center to use in transmitting message traffic because it denies to more important use the circuits being so employed. If a message cannot be sent by telegraph, telegraph printer, radio, or messenger, the writer should be notified so that he personally or one of his representatives may communicate direct with the addressee by telephone. The telephone in the message center, if installed, is not intended for the transmission of message traffic but may be found helpful in contacts with neighboring message centers, transmission agencies, and offices relative to the transmission and delivery of messages.

b. Normal form.—The following table lists the data of interest to the message center which should appear, in whole or in part, on messages to be transmitted by electrical means in the normal form. Transmission of messages by radio in the normal form is used only between divisions and higher units.

General division	Part	Example	When used
Heading	Destination	{Send to BA1 or Send to I Corps	} Always.
	Operating instructions	F or G and/or Y	
Text	Classification	O, P, or NITE	If required.
	Group count	GR7	Always.
	Date of origin	DATE, or SIXTEENTH	Always.
	Writer's number	NR26	If available.
	Code or cipher indicator	DFCT1	If essential.
	Message	IXOW VAWL COTZ UKZH.	Always.
	Time signed	638P	Always.

c. Abbreviated form.—The following table lists the data of interest to the message center which should appear, in whole or in part, on messages to be transmitted by electrical means in the abbreviated form. The abbreviated form is the only form authorized within the division for transmission of messages by radio. The abbreviated form may be used between divisions and higher units if desired.

General division	Part	Example	When used
Heading....	Destination.....	{Send to FA1 or.....	}Always. If required. Urgent message only. If essential. Always. Always.
	Operating instructions..	{Send to 1st FA.....	
	Classification.....	F or G and/or Y..... O.....	
Text.....	Code or cipher indicator.	DFCT1.....	}Always. If essential. Always. Always.
	Message.....	IXOW VAWL COTZ UKZH.	
	Time signed.....	726P.....	

■ 38. ARMY AND NAVY METHODS OF SPECIFYING TIME.—*a.* The ordinary 12-hour clock will be used in the Army. The new day starts at midnight. Time will be transmitted in three or four numeral groups with an "A" added if before noon and a "P" added for all times after noon to midnight. The words "noon" and "midnight" are used for those times.

b. The Navy uses the 24-hour clock. Navy 24-hour time is always expressed as a group of four numerals. The first two numerals of the group denote the hour and the last two numerals the minute after the hour. Ordinary or 12-hour time may be converted to 24-hour time by adding 12 hours to all times from 1:00 P. M. to midnight inclusive.

c. Examples of time as expressed in the Army and Navy are shown below:

Army	Time	Navy	Army	Time	Navy
Midnight.....	Midnight.....	2400	Noon.....	Noon.....	1200
1201A.....	12:01 a. m.....	0001	1259P.....	12:59 p. m.....	1259
117A.....	1:17 a. m.....	0117	608P.....	6:08 p. m.....	1808
1135A.....	11:35 a. m.....	1135	1159P.....	11:59 p. m.....	2359

■ 39. STATION LISTS.—Operation of the message centers of divisions and higher units is facilitated when station lists are provided. The station list gives the location of the various headquarters and elements of the command. It is prepared by The Adjutant General's Office.

■ 40. TELEPHONE DIRECTORY.—In signal operation instructions, the message center is furnished the telephone directory names of all headquarters and the numbers of all offices with which it may be concerned. Telephone directory names and numbers are not intended for secrecy but are prescribed for purposes of simplicity, accuracy, and speed in the handling of telephone calls. (See example on page 280.)

■ 41. RADIO, TELEGRAPH, AND VISUAL CALL SIGNS.—In signal operation instructions, the message center is furnished a list of the call signs of radio, telegraph, and visual stations with which it may be concerned. These call signs are used by the message center to expedite the handling of messages. (See example facing page 284.)

■ 42. LETTERING.—In order to secure legibility in copying code messages and in other cases where a lettered character better serves the purpose, the following system of lettering is prescribed. The examples shown below indicate how letters and numerals should be formed and the sequence to be followed in making the various strokes:



The straight line I is the foundation stroke. The letters E, Z, X, and K are made slightly smaller at the top. The letters H, E, and F have the center horizontal strokes slightly above the middle. The letters X, Y, and K have the junction slightly above the middle.



The letters O, Q, C, and G are made in circular form. The letter B is slightly smaller at the top and has the center horizontal part slightly above the middle. The letters R and S are slightly smaller at the top.

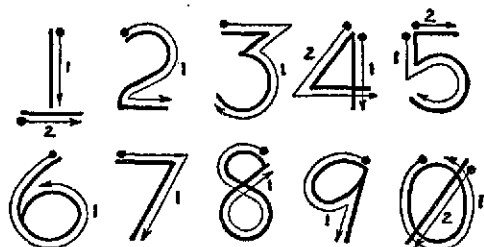

The bar under the numeral 1, the top of the 5 and 7, and the bottom of 2, are straight lines. The numeral 1 has a bar under it, slightly below the stem, to distinguish it from the letter I and the cipher 0 has a bar diagonally through it to distinguish it from the letter O.

SECTION V

MILITARY CRYPTOGRAPHY

■ 43. USE OF CRYPTOGRAMS.—All messages to be transmitted by radio or other means, when danger of hostile interception exists, are cryptographed except in the following cases:

a. When the tactical situation is such that time cannot be spared for cryptographing and when the information to be transmitted, if intercepted by the enemy, cannot be acted upon in time to influence the situation in question, a com-

manding officer or his authorized representative may order the transmission of a message in plain language by a radio station serving his headquarters or command. Such written messages will be marked "Send in clear," over the signature of the commander or his authorized representative.

b. Commanders may authorize the normal transmission of artillery fire-control messages in clear.

c. All cryptographing and decryptographing of messages at a headquarters are performed in the message center, except as authorized in paragraph 32, unless the message requires a code or cipher not in the possession of the message center. The message center is provided with the authorized codes, cipher devices, and keys.

d. If it becomes necessary to modify the wording of a message in order to cryptograph it or to facilitate cryptographing, the modified text will be submitted to the writer for approval before transmission.

■ **44. DEFINITIONS.**—A knowledge of the following terms is essential for all personnel handling code and cipher messages:

a. "Plain text," "clear text," or "plain language" is the text of a message which, on its face, conveys an intelligible meaning in a spoken language.

b. "Secret text" or "secret language" is the text of a message which, on its face, conveys no intelligible meaning in any spoken language. The secret text of a message constitutes a cryptogram.

c. "Cryptography" is the science which embraces all the methods and devices whereby plain text may be converted into secret text.

d. "Cryptograms" are of three fairly distinct types as follows:

(1) *Cipher*.—A cryptogram in cipher is one which has been produced by taking the individual letters of the plain text as units and applying to them either or both of two cryptographic processes known as "transposition" and "substitution" explained below. The resulting secret text is called "cipher text" and the operation of producing it is called "enciphering"; the reverse operation, that of reproducing

the plain text from the cipher text by a direct reversal of the steps involved in its enciphering, is called "deciphering." The basis of every cipher system is an agreement between correspondents covering the general method and the steps to be followed in cryptographing. That portion of the agreement which specifically controls the steps under the general method is termed the "key." The key is usually of a variable nature, changeable at the will of the correspondents. Normally it consists of an easily remembered word, phrase, or sentence; or of a number or series of numbers derivable from a word, phrase, or sentence.

(a) *Transposition cipher*.—The cryptographic process known as transposition consists in rearranging the letters constituting the plain text (rarely syllables or whole words) so that the resultant text becomes unintelligible. The letters undergo no change in identity; only their relative order is altered. A cryptogram which has been produced in this way is termed a "transposition cipher."

(b) *Substitution cipher*.—The cryptographic process known as substitution consists in replacing the letters constituting plain text by other letters, figures, symbols, or the like. Here the letters undergo a change in identity without a change in their relative order. A cryptogram which has been produced in this way is termed a "substitution cipher."

(c) *Combined cipher*.—When both of these processes have been applied in producing a cryptogram, the latter is termed a combined "substitution-transposition cipher."

(2) *Code*.—(a) A cryptogram in code is one which has been produced by taking whole sentences, phrases, words, letters, or numbers of plain text as units and replacing them by arbitrary groups of symbols given as their equivalents in a code book. The resulting secret text is called "code text" and the operation of producing it is called "encoding"; the reverse operation, that of reproducing the plain text from the code text by reference to the code book, is called "decoding." A one-part code consists of only one section which serves for either encoding or decoding. A two-part code consists of two sections, one section arranged to facilitate encoding and the other to facilitate decoding. A one-part code is very much less secure than a two-part code.

(b) Code groups or code words are arbitrary groups of symbols constituting code text. They usually consist of letters or figures or rarely of both letters and figures.

(3) *Enciphered code*.—A cryptogram in enciphered code is one which has been produced by first encoding the plain text and then enciphering the code text.

e. To "cryptograph" a message is to convert its plain text into secret text. This is a convenient term to use in referring to the processes involved without indicating or specifying whether they are methods of enciphering or encoding.

f. To "decryptograph" a message is to reconvert its secret text into plain text by a direct reversal of the operations involved in its cryptographing. This is a convenient term to use in referring to the processes involved without indicating whether the cryptogram is in cipher, in code, or in enciphered code. As enciphering and encoding are forms of cryptographing, so deciphering and decoding are forms of decryptographing.

g. "Cryptanalysis" is the name applied to the steps and processes involved in converting cryptograms (usually of hostile origin) into plain text by means other than those normally employed in decryptographing messages of friendly origin.

■ 45. SAFETY AFFORDED BY CRYPTOGRAPHY.—Codes and ciphers are used in messages for either or both of two purposes; condensing messages and maintaining secret, except from the addressee, the contents of messages. Unless secrecy is accomplished with certainty, all of the additional time, labor, and danger of error involved in cryptographic messages is wasted; moreover, the correspondents may be lulled into a false sense of security in the belief that their messages are secret, when, in fact, the enemy may have cryptanalyzed them and taken action accordingly. With the increased use of radio as well as other means of electrical communication, the safeguarding of codes and ciphers has assumed a paramount importance. In general it may be stated that no cryptographic system suitable for a voluminous official correspondence is absolutely proof against the organized, co-operative efforts of a large and well-trained staff of crypt-

analysts. Practically every cipher system that has ever been employed for military purposes has been solved and practically any code book can be reconstructed by analysis, given a sufficient number of cryptograms and the personnel and time necessary to accomplish it.

■ 46. COMPARISON OF CODES AND CIPHERS.—*a.* Each of these two general methods of secret communication is needed in the military service. The principal factors to be taken into account in comparing code and cipher methods as systems of secret communication are—

- (1) Simplicity, rapidity, practicability.
- (2) Secrecy.
- (3) Accuracy.
- (4) Economy.

b. In general, it may be said that code is a more rapid and more simple method of secret communication than is cipher. The processes of enciphering and deciphering require very close mental attention to avoid errors, and are usually much slower than those of encoding and decoding which more nearly approach automatic processes and thus require less concentrated mental effort. This is of greatest importance in the combat zone. There are some very small cipher devices which tend to reduce the mental strain to a minimum, but in general the cryptograms they yield are not as secret as those produced by a good code, especially when many messages are available for interception by the enemy.

c. Code systems are, on the whole, more secret than cipher systems, depending upon—

- (1) The type of code. A two-part code is more secret than a one-part code.
- (2) The extent of its vocabulary or contents.
- (3) The extent to which the code is used; that is, the number of messages transmitted.

d. Furthermore, the solution of one message does not as a rule entail the immediate breakdown of the whole system, with the consequent solution of all other messages in the same key, as is the case in ciphers. On the other hand, in the case of code it is absolutely necessary to guard at all times the code book so that it does not fall into the hands of

the enemy. Actual possession is not always necessary, for a single opportunity to copy or memorize certain portions is sufficient to compromise the whole code.

e. On the whole, it may be said that code systems are less accurate than cipher systems and are more subject to the necessity for repetition of messages. This is because a mistake in one or two code groups may obscure, alter, or render unintelligible the meaning of a whole message, whereas, in the case of ciphers, the meaning of a few letters which are in error may be supplied by the context.

f. Since code text is usually shorter than the equivalent plain text, the latter is more economical to handle than cipher. This is of great importance where the amount of signal traffic is heavy. On the other hand, for the purpose of maintaining secrecy in military communication, codes of the two-part type must be changed rather frequently. This necessitates repeated processes of preparation, printing, and distribution, all of which take much time and labor.

■ 47. AUTHORIZED MILITARY CODES.—See AR 380-5 for the manner in which codes are authorized to be used. Among others, the codes listed below are authorized for general use in the military service. See paragraph 100 for their code indicators and the number of characters per code group. Training and maneuver editions of certain confidential codes are given a restricted classification when published. Blank groups are left in codes for the assignment of special meanings by commanders. These meanings are published in signal operation instructions as supplements to the codes. (See examples on pages 266 and 268.)

a. *War Department Telegraph Code.*—This code is a non-secret code primarily intended for economy. It furnishes no security from code experts and should never be used for encoding secret messages. It is issued to all those who are required to handle any considerable volume of business by telegraph, radio, or cable.

b. *Division Field Code.*—This code is issued to message centers of divisions and all lower tactical units down to and including the battalion, and in peacetime for training purposes, it may be issued down to companies.

c. Aerial Observation Codes and Panels.—These codes are prepared by the War Department or the headquarters of the field forces and are issued to all units that engage in communication between ground and air.

(1) The *Fire-Control Code* is fixed and is used in adjustment of fire.

(2) The *Air-Ground Liaison Code* is employed in general observation and reconnaissance. In emergencies it may also be used in the absence of other cryptographic means for communication between forward ground stations. It is revised frequently for purposes of secrecy by rearrangement of code groups and their meanings.

d. Special codes.—Such codes as address and signature codes, map coordinate codes, geographic, meteorological, and supply catalog codes, as well as appendixes to the various codes listed above, will be published from time to time.

e. Prearranged messages.—In traffic by radiotelephone, it is often desirable to use some form of prearranged message or groups of letters to indicate meanings which will not readily be apparent to the enemy. These messages or groups will be changed frequently and may be prepared by local commanders as appropriate. These codes or messages being of a temporary nature, the prohibition as to mixing of clear and secret text does not apply. A map coordinate code is particularly appropriate for use in conjunction with such messages. For example, "Advance guard motors move forward to next position" might be transmitted as "CJ" or a prearranged phrase might be used instead of a letter group. For example, "Objective taken" might be transmitted "The fox is in his hole."

■ 48. AUTHORIZED MILITARY CIPHERS.—Among others, the following ciphers are authorized for use in the military service:

a. Cipher device M-94.—This cipher device is explained in section VI.

b. Telegraph printer cipher system.—This is a cipher system operated in connection with telegraph printers and is used only between the higher headquarters where traffic is very great.

■ 49. RULES FOR USE OF CODES AND CIPHERS (AR 380-5).—The following general rules govern the use of codes and ciphers:

a. The instructions contained in each code book or furnished with each cipher system must be carefully studied and thoroughly understood before the code or cipher is used.

b. Care should be exercised to prevent the loss or compromise of a code book or cipher key. If a code book is lost or possibly compromised, the fact should be reported promptly to higher headquarters.

c. Except in emergency, no code or cipher which has not been approved by higher authority should be employed within any unit.

d. Care should be exercised that only one edition of a code of a particular class, or only one cipher key is being used within a unit at one time. When a code is replaced by a new code or a new edition, the replaced code will be destroyed by burning unless otherwise ordered.

e. Cryptographic messages should be short and concise. Long messages facilitate solution by the enemy.

f. Never repeat a message in a code or cipher other than the one in which it was originally sent. If the enemy has already solved one of the codes or cipher keys used, he will translate the message by that code or cipher key and will thus be given clues to the solution of the other code or cipher key.

g. Never cryptograph a message which has been sent previously in clear and never send a message in clear which has been sent previously as a cryptogram. If the enemy compares the cryptographic message with the clear message he will be able to break into the code and solve other messages, or in the case of ciphers, he will have the key for the solution of all other messages.

h. Never mix secret and clear text in the same message except as permitted in paragraph 47*e*. This applies also to abbreviations and signs of punctuation which are equivalent to clear text. If clear text of any kind whatever is left in the message, the enemy can more easily discover the meaning of the secret text. If cryptographed at all the entire message must be cryptographed.

i. A cryptographed message never should be filed with the clear message. (See par. 34*d*.)

j. Capital letters should be employed throughout in writing cryptograms in order to avoid errors. In the case of code, the grouping of the letters of the code text corresponds to the length of the code groups as given by the book; in the case of cipher, the text is written and transmitted in groups of five letters. (See par. 42.)

SECTION VI

DESCRIPTION AND USE OF CIPHER DEVICE M-94

■ 50. PURPOSE AND DISTRIBUTION.—Cipher device M-94 is a cryptographic instrument that is an item of equipment issued by the Signal Corps to all message centers as one of the authorized means for secret communication. It is also an item of equipment possessed by all naval units and stations, including those of the Marine Corps, and can be employed in certain classes of secret intercommunication between the Army and the Navy when specific arrangements therefor have been made by the appropriate commanders.

■ 51. DESCRIPTION.—*a.* The device is made of aluminum alloy and consists of the following parts:

(1) A central shaft, the left end of which terminates with a projecting shoulder, the right end of which is threaded.

(2) A set of 25 alphabet disks, on the rim of each of which there is stamped a different, completely disarranged alphabet.

(3) A guide-rule disk, consisting of a blank or unlettered disk from which projects a guide rule.

(4) A retaining plate, consisting of a thin disk upon one surface of which is stamped the name and type number of the device.

(5) A knurled thumb nut.

b. Each disk has a hole at the center suitable for mounting it upon the central shaft upon which the disk can be revolved forward or backward. The left face of each alphabet disk is provided with a circle of 26 equidistant slots; the right face is cupped and carries at one point on the inside rim of this cup a small projecting lug. The guide-rule disk

also carries such a lug. When the disks are assembled upon the shaft, the lug on each disk engages with one of the slots on the adjacent disk on the right and thus the disks can be held in engagement in any desired relative positions by screwing down the knurled thumb but against the retaining plate which is inserted between the last alphabet disk and the nut.

c. When the thumb nut and the retaining plate are removed and the alphabet disks are taken off the shaft, it will be noted that each alphabet disk is stamped on its inside or cup surface with an identifying symbol consisting of a number that is above the central hole and a letter that is below it. The numbers run from 1 to 25, inclusive, the letters from B to Z, inclusive. These symbols are employed to designate the sequence in which the alphabet disks are to be assembled upon the shaft in cryptographing or decryptographing messages as described in paragraph 53. Either symbol may be used for this purpose (as prearranged) but for the present only the numerical identifying symbols will be so used.

■ 52. NECESSITY FOR KEY AND PROVIDING FOR CHANGES THEREIN.—*a.* Messages cryptographed by the same sequence of alphabet disks can remain secure against solution by a well-organized and efficient enemy cryptanalytic section for only a relatively short time. It is impossible to state exactly how long, because solution depends upon a number of variable factors; a conservative estimate would place the minimum at 6 hours, the maximum at 2 or 3 days. For this reason it is necessary to change the sequence from time to time, and the method for determining or indicating the new sequence must be agreed upon in advance and thoroughly understood by all who are to use the instrument.

b. The sequence in which the alphabet disks are assembled upon the shaft constitutes the key in this cipher system. When a change in key is to take place, exactly what the new key will be and the exact moment that it is to supersede the old key will be determined by the proper commander and will be published in signal operation instructions. (For example, see page 272.)

■ 53. DETAILED INSTRUCTIONS FOR SETTING DEVICE TO A PRE-DETERMINED KEY.—*a.* The method prescribed herein is based upon a key word or key phrase from which the sequence of numbers constituting the key for assembling the alphabet disks may be obtained by following a simple, standardized procedure. The reason for employing such a procedure is that it makes it possible to derive at will a relatively long sequence of numbers (which would be difficult to remember) from a word or phrase (which is easy to remember) and thus eliminates the necessity of carrying the key in written form upon the person. It is this basic key word or key phrase which is communicated throughout the command in signal operation instructions. The exact method of deriving the numerical key sequence from the key word or key phrase is given step by step in *b* below.

b. Assume that the key phrase so communicated is CHINESE LAUNDRY. The following are the detailed steps to be followed in deriving the numerical key sequence:

(1) A set of rows of cross section squares, 25 squares in each row, is prepared. (Prepared sheets of 1/4-inch squares are suitable.)

(2) In the top row the series of numbers 1, 2, 3-25 are inserted. Thus:

1	2	3	4	5	6	7	8	9	10	11	12	13	14	15	16	17	18	19	20	21	22	23	24	25
---	---	---	---	---	---	---	---	---	----	----	----	----	----	----	----	----	----	----	----	----	----	----	----	----

(3) Beginning under the number 1, the successive letters of the key phrase are written in the second row of squares under the successive numbers. Thus:

1	2	3	4	5	6	7	8	9	10	11	12	13	14	15	16	17	18	19	20	21	22	23	24	25	
C	H	I	N	E	S	E	L	A	U	N	D	R	Y												

(4) The key phrase is extended by repetition until there is a letter under the number 25, making a key sequence of 25 letters. If the key consists of a word or phrase containing

more than 25 letters, those after the twenty-fifth letter are merely omitted. Thus:

1	2	3	4	5	6	7	8	9	10	11	12	13	14	15	16	17	18	19	20	21	22	23	24	25
C	H	I	N	E	S	E	L	A	U	N	D	R	Y	C	H	I	N	E	S	E	L	A	U	N

(5) The letters of the key sequence are now numbered serially from left to right in accordance with the relative position that each letter occupies in the ordinary alphabet. Since the letter A comes first in the ordinary alphabet and since this letter occurs twice in the illustrative key sequence, the number 1 is written under the first appearance of A in this sequence and the number 2 is written under its second appearance. Thus:

1	2	3	4	5	6	7	8	9	10	11	12	13	14	15	16	17	18	19	20	21	22	23	24	25
C	H	I	N	E	S	E	L	A	U	N	D	R	Y	C	H	I	N	E	S	E	L	A	U	N
								1																2

(6) The next letter in the ordinary alphabet is B. The key sequence is carefully examined to see if it contains the letter B. Since this letter does not appear in the illustrative key sequence, the latter is examined to see if it contains the letter C. This letter occurs twice in the illustrative key sequence and the first C, therefore, is assigned the number 3, the second C the number 4. Thus:

1	2	3	4	5	6	7	8	9	10	11	12	13	14	15	16	17	18	19	20	21	22	23	24	25
C	H	I	N	E	S	E	L	A	U	N	D	R	Y	C	H	I	N	E	S	E	L	A	U	N
3									1					4										2

(7) The next letter in the ordinary alphabet is D, which, being present in the key sequence, is assigned the next number, and so on. Thus, the process is continued until each letter has been assigned a number. The work must be done carefully so as not to overlook a single letter. If an error is made in the early stages of the work, it necessitates starting anew. The operator should be especially careful with letters which immediately follow one another in the ordinary alphabet but are present in the key sequence in reversed order, such as ED, FE, ON, and so on. It is easy to make a mis-

take in such cases and to assign numbers to these letters in a sequence that is the reverse of what it should be.

(8) When the numbering process has been completed and if the work has been correctly performed, it will be found that every letter of the key sequence has a number under it and that the greatest number that appears is 25. If this is not the case, it is an immediate signal that an error has been made. It cannot, however, be assumed that so long as every letter has a number under it, with the greatest number 25, this is immediate and conclusive proof of accuracy in the work. The operator should invariably check his work; better yet, if two clerks are available, each one should derive the numerical key independently and check final results by comparison.

(9) The key phrase selected as an example in the foregoing description yields the following numerical key:

1	2	3	4	5	6	7	8	9	10	11	12	13	14	15	16	17	18	19	20	21	22	23	24	25	
C	H	I	N	E	S	E	L	A	U	N	D	R	Y	C	H	I	N	E	S	E	L	A	U	N	
3	10	12	16	6	21	7	14	1	23	17	5	20	25	4	11	13	18	8	22	9	15	2	24	19	

(10) It is this sequence of numbers which indicates the order in which the successive alphabet disks are to be assembled upon the shaft from left to right. Thus, according to the foregoing key sequence, alphabet disk No. 3 comes first, that is, immediately to the right of the guide-rule disk; alphabet disk No. 10 comes next, and so on. Alphabet disk No. 19 is the last in this particular key, and after it has been placed on the shaft, the retaining plate and thumb nut are added and the latter screwed down a distance sufficient to keep the assembly together and yet permit of revolving individual disks freely upon the shaft. The device is now ready for use in either cryptographing or decryptographing messages.

■ 54. CRYPTOGRAPHING A MESSAGE.—Suppose the following message is to be enciphered with the key used in paragraph 53:

CO 3d INF

HAVE JUST REACHED EASTERN EDGE OF WOODS
ALONG 552-592 ROAD WILL REMAIN IN OBSERVATION

CO 2d BN

a. The message is written down on the work sheet underneath the key lines of 25 letters each. Space is left under each line for the insertion of cipher letters. For procedure in connection with abbreviations and numbers appearing in the text of messages, see paragraph 55. Thus:

1	2	3	4	5	6	7	8	9	10	11	12	13	14	15	16	17	18	19	20	21	22	23	24	25	
C	H	I	N	E	S	E	L	A	U	N	D	R	Y	C	H	I	N	E	S	E	L	A	U	N	
3	10	12	16	6	21	7	14	1	23	17	5	20	25	4	11	13	18	8	22	9	15	2	24	19	
H	A	V	E	J	U	S	T	R	E	A	C	H	E	D	E	A	S	T	E	R	N	E	D	G	

E	O	F	W	O	O	S	A	L	O	N	G	F	I	V	E	F	I	V	E	T	W	O	D	
---	---	---	---	---	---	---	---	---	---	---	---	---	---	---	---	---	---	---	---	---	---	---	---	--

A	S	H	F	I	V	E	N	I	N	E	T	W	O	R	O	A	D	W	I	L	L	R	E	M
---	---	---	---	---	---	---	---	---	---	---	---	---	---	---	---	---	---	---	---	---	---	---	---	---

A	I	N	I	N	O	B	S	E	R	V	A	T	I	O	N
---	---	---	---	---	---	---	---	---	---	---	---	---	---	---	---

b. By revolving the disks upon the shaft one by one, the first 25 letters of the message are alined to form a continuous horizontal row of letters reading from left to right along the outside of the cylinder. The guide rule will be found very convenient in marking the row upon which the letters are being alined, thus relieving the eyes of unnecessary strain and reducing the chance of making errors. After all 25 letters have been alined, the assembly is locked in position so that no disk can become displaced accidentally in further manipulation of the cylinder. *The row of letters is immediately checked to make sure that no displacement has occurred among the first few disks while manipulating the last few.*

c. The outside of the cylinder now presents a series of 26 rows of letters of which 24 rows are fully visible, the other two being hidden or partially obscured by the guide rule.

One of the 24 visible rows is the plain-text row, that has just been set up and the other 23 rows are cipher-text rows *any one of which may be selected to represent the plain-text row*. One of these cipher-text rows is selected at random and the letters composing this row are written underneath the row of plain-text letters on the work sheet. Thus, supposing the row beginning JUKLD has been selected, the first cipher line will read as follows:

1	2	3	4	5	6	7	8	9	10	11	12	13	14	15	16	17	18	19	20	21	22	23	24	25
C	H	I	N	E	S	E	L	A	U	N	D	R	Y	C	H	I	N	E	S	E	L	A	U	N
3	10	12	16	6	21	7	14	1	23	17	5	20	25	4	11	13	18	8	22	9	15	2	24	19
H	A	V	E	J	U	S	T	R	E	A	C	H	E	D	E	A	S	T	E	R	N	E	D	G
J	U	K	L	D	Y	K	I	T	Z	I	I	V	C	Y	C	V	U	Y	V	P	Y	W	H	J

It is not necessary to make any record on the work sheet as to which cipher-text row (above or below the plain-text row) was selected, nor is it necessary to indicate it in any manner whatever in the cipher message.

d. The thumb nut is loosened but not removed from the shaft. The next 25 letters of the message are alined, the thumb nut screwed down against the retaining plate, the letters in the alinement are checked, and again any one of the 23 visible cipher-text rows, except the one used to encipher the first line, is selected at random for the cipher text. The letters in the row selected are written down under the second line of plain-text letters on the work sheet. Thus, supposing the row beginning YUYEZ was selected, the work sheet now appears as follows:

1	2	3	4	5	6	7	8	9	10	11	12	13	14	15	16	17	18	19	20	21	22	23	24	25	
C	H	I	N	E	S	E	L	A	U	N	D	R	Y	C	H	I	N	E	S	E	L	A	U	N	
3	10	12	16	6	21	7	14	1	23	17	5	20	25	4	11	13	18	8	22	9	15	2	24	19	
H	A	V	E	J	U	S	T	R	E	A	C	H	E	D	E	A	S	T	E	R	N	E	D	G	
J	U	K	L	D	Y	K	I	T	Z	I	I	V	C	Y	C	V	U	Y	V	P	Y	W	H	J	
E	O	F	W	O	O	S	A	L	O	N	G	F	I	V	E	F	I	V	E	T	W	O	D		
Y	U	Y	E	Z	D	H	V	U	Z	D	B	Q	P	O	Z	M	C	F	N	B	J	J	I	X	

e. This process is continued in similar manner with the third line of the plain-text message. *It should never be made a practice to "favor," that is, frequently to select a particular cipher-text row above or below the plain-text row.* As irregular a selection as possible should be made, and the selection of the cipher-text row immediately above the plain-text row or immediately below the lower edge of the guide-rule should be avoided. Suppose these instructions have been followed and that there has been selected for the cipher-text row representing the third plain-text line of the message the row beginning E A P T H, the message now stands as follows:

1	2	3	4	5	6	7	8	9	10	11	12	13	14	15	16	17	18	19	20	21	22	23	24	25
C	H	I	N	E	S	E	L	A	U	N	D	R	Y	C	H	I	N	E	S	E	L	A	U	N
3	10	12	16	6	21	7	14	1	23	17	5	20	25	4	11	13	18	8	22	9	15	2	24	19
H	A	V	E	J	U	S	T	R	E	A	C	H	E	D	E	A	S	T	E	R	N	E	D	G
J	U	K	L	D	Y	K	I	T	Z	I	I	V	C	Y	C	V	U	Y	V	P	Y	W	H	J
E	O	F	W	O	O	S	A	L	O	N	G	F	I	V	E	F	I	V	E	T	W	O	D	
Y	U	Y	E	Z	D	H	V	U	Z	D	B	Q	P	O	Z	M	C	F	N	B	J	J	I	X
A	S	H	F	I	V	E	N	I	N	E	T	W	O	R	O	A	D	W	I	L	L	R	E	M
E	A	P	T	H	Y	O	W	H	K	W	T	N	Y	G	M	P	R	Z	J	I	F	A	D	

f. There are left only 16 letters to be enciphered, not enough to make a complete row of 25 letters. This, however, makes no difference in procedure; these 16 letters are merely aligned and a cipher-text row is selected to represent them. Supposing the row beginning MEQRH is selected, the message now stands as follows:

1	2	3	4	5	6	7	8	9	10	11	12	13	14	15	16	17	18	19	20	21	22	23	24	25
C	H	I	N	E	S	E	L	A	U	N	D	R	Y	C	H	I	N	E	S	E	L	A	U	N
3	10	12	16	6	21	7	14	1	23	17	5	20	25	4	11	13	18	8	22	9	15	2	24	19
H	A	V	E	J	U	S	T	R	E	A	C	H	E	D	E	A	S	T	E	R	N	E	D	G
J	U	K	L	D	Y	K	I	T	Z	I	I	V	C	Y	C	V	U	Y	V	P	Y	W	H	J

E O F W O O D S A L O N G F I V E F I V E T W O D
 Y U Y E Z D H V U Z D B Q P O Z M C F N B J J I X

A S H F I V E N I N E T W O R O A D W I L L R E M
 E A P T H Y O W H K W W T N Y G M P R Z J I F A D

A I N I N O B S E R V A T I O N
 M E Q R H B P O J T Y U Q N T W

g. The cipher text is now copied on the message form in 5-letter groups. It is as follows:

JUKLD YKITZ IIVCY CVUYV PYWHJ
 YUYEZ DHVUZ DBQPO ZMCFN BJJIX
 EAPTH YOWHK WWTNY GMPRZ JIFAD
 MEQRH BPOJT YUQNT W

h. The last group of the cipher message is, however, not a complete group of 5 letters. It is made so by adding four X's. *These are not to be cryptographed;* they are added merely to complete the last cipher group. The final message becomes as shown below:

JUKLD YKITZ IIVCY CVUYV PYWHJ
 YUYEZ DHVUZ DBQPO ZMCFN BJJIX
 EAPTH YOWHK WWTNY GMPRZ JIFAD
 MEQRH BPOJT YUQNT WXXXX

The message as it now reads is but one of many different forms in which this same message could appear externally,

depending on exactly which of the available cipher-text rows is selected for each line of the encipherment.

■ 55. CRYPTOGRAPHING ABBREVIATIONS, PUNCTUATION SIGNS, AND NUMBERS.—*a.* Authorized abbreviations appearing in the original plain-text message may be enciphered as abbreviations without periods. *Examples:* Am Tn=AMTN; E. V. Brown Sch=EVBROWNSCH.

b. Normally the writer of a message spells out the punctuation signs he wishes transmitted, for example, STOP, COMMA, COLON, etc. If a message contains punctuation signs not so spelled out, they are spelled out and transmitted.

c. Cardinal and ordinal numbers when spelled out in letters in the original plain-text message are always enciphered exactly as spelled.

d. Cardinal numbers when expressed in figures in the original plain-text message must always be spelled out digit by digit in cryptographing. *Examples:*

4=FOUR

40=FOURZERO (*not* FORTY)

400=FOURZEROZERO (*not* FOUR HUNDRED)

455=FOURFIVEFIVE

2005=TWOZEROZEROFIVE

12.01 A. M.=ONETWOZEROONEAM

5.15 P. M.=FIVEONEFIVEPM

e. Ordinal numbers above the ordinal number 10th, when expressed in figures followed by "d," or "th," are cryptographed merely as digits spelled out without adding the "d" or "th". The omission of the "d" or the "th" will cause no confusion or ambiguity. *Examples:* 3d Bn=THIRDBN; 7th Pack Tn=SEVENTHPACKTN; 11th Regt=ONEONEREGT; 403d Am Tn=FOURZEROTHREEAMTN.

■ 56. DECRYPTOGRAPHING A MESSAGE.—*a.* Knowing the key word or key phrase, the numerical key is developed as described in paragraph 53 and the set of alphabet disks is assembled accordingly. The message to be decryptographed is written down in lines of 25 letters on cross section paper, if available, space being left under each line for the insertion

of plain-text letters. Using the cipher message given in paragraph 54h, it appears under the key in the following form:

1	2	3	4	5	6	7	8	9	10	11	12	13	14	15	16	17	18	19	20	21	22	23	24	25
C	H	I	N	E	S	E	L	A	U	N	D	R	Y	C	H	I	N	E	S	E	L	A	U	N
3	10	12	16	6	21	7	14	1	23	17	5	20	25	4	11	13	18	8	22	9	15	2	24	19
J	U	K	L	D	Y	K	I	T	Z	I	I	V	C	Y	C	V	U	Y	V	P	Y	W	H	J

Y	U	Y	E	Z	D	H	V	U	Z	D	B	Q	P	O	Z	M	C	F	N	B	J	J	I	X
---	---	---	---	---	---	---	---	---	---	---	---	---	---	---	---	---	---	---	---	---	---	---	---	---

E	A	P	T	H	Y	O	W	H	K	W	T	N	Y	G	M	P	R	Z	J	I	F	A	D
---	---	---	---	---	---	---	---	---	---	---	---	---	---	---	---	---	---	---	---	---	---	---	---

M	E	Q	R	H	B	P	O	J	T	Y	U	Q	N	T	W
---	---	---	---	---	---	---	---	---	---	---	---	---	---	---	---

b. The first 25 letters of the cryptogram are set up on the device, the letters being alined in a row from left to right just above the guide rule. Fixing the disks in this position by screwing down the thumb nut, the whole cylinder is turned slowly, forward or backward, and each row of letters is carefully examined. One of these rows *and only one* will read intelligibly all the way across from left to right. That is the row which gives the plain text for the first 25 cipher letters. These letters are inserted in their proper place on the work sheet, giving the following:

1	2	3	4	5	6	7	8	9	10	11	12	13	14	15	16	17	18	19	20	21	22	23	24	25
C	H	I	N	E	S	E	L	A	U	N	D	R	Y	C	H	I	N	E	S	E	L	A	U	N
3	10	12	16	6	21	7	14	1	23	17	5	20	25	4	11	13	18	8	22	9	15	2	24	19
J	U	K	L	D	Y	K	I	T	Z	I	I	V	C	Y	C	V	U	Y	V	P	Y	W	H	J
H	A	V	E	J	U	S	T	R	E	A	C	H	E	D	E	A	S	T	E	R	N	E	D	G

c. The thumb nut is then loosened, the next 25 cipher letters are set up, the assembly is locked into position, again

the whole cylinder is slowly revolved, and the plain-text row of letters found. These are written down in their proper place and the process is continued with the rest of the cipher letters until the message has been completely decryptographed.

d. In the case of a cryptogram the last few letters of which do not form a complete set of 25, if any difficulty is experienced in picking out the plain-text row, the context of the preceding part of the message should give a good clue. In the case of the illustrative message above, it should be realized that the last four letters of the cryptogram are not to be decryptographed since they are merely added after cryptographing to make the last group of the cryptogram a complete group of five letters. They are omitted from the work sheet.

e. The plain-text message is then copied on a message form. The code clerk may, if authorized to do so by the message center chief, convert numbers which had to be spelled out in letters to permit of their cryptographing into their equivalent arabic figures. Abbreviations and punctuation signs are, however, copied exactly as they stand in the decryptographed message.

■ 57. PRECAUTION.—*When in danger of capture, the alphabet disks of a device that has recently been used to cryptograph or decryptograph a message must be taken off, thoroughly disarranged, and reassembled.*

CHAPTER 3

MESSENGER COMMUNICATION

	Paragraphs
SECTION I. General.....	58-60
II. Training of personnel.....	61-66
III. Employment.....	67-76
IV. Dropped messages.....	77-80
V. Pick-up of messages.....	81-85

SECTION I

GENERAL

■ 58. **NECESSITY.**—Messenger communication is needed and used by all units from the smallest to the largest. Both personnel and equipment are necessary for messenger communication, but of all means of signal communication, it is most dependent upon personnel, and only to a minor degree upon equipment. All persons in the military service are enjoined to assist messengers carrying important orders or messages by pointing out the route, giving directions, and providing transportation if necessary.

■ 59. **PERSONNEL.**—*a.* The personnel needed for messenger communication consists primarily of messengers; but agents, airplane pilots and observers, and others are required in special situations. Usually messengers are a part of message center sections of units operating a message center, but if they are not, they should be attached to those sections for training and employment.

(1) Messengers are persons who carry messages as defined in paragraph 5. In the field a dismounted messenger is named a runner. Other messengers are named according to the means of transport used by them; as, mounted (horse), bicycle, motorcycle, motor, and airplane.

(2) Agents are defined and their duties are prescribed in other publications.

b. Because of the great dependence of messenger communication upon the personnel used in it, that personnel

should be selected with the following characteristics as a basis:

(1) Motorcycle, bicycle, mounted messengers, and runners should be young and sturdy.

(2) Messengers, especially runners and agents, require courage to a marked degree. They are often sent on important missions the accomplishment of which requires extraordinary self-reliance and endurance.

(3) Messengers and agents require an intelligence above the average. They must be able to comprehend simple oral orders, to use compasses and maps, and to understand changes in tactical situations. They must be resourceful.

(4) Extreme loyalty is necessary to insure trustworthiness. In messengers, loyalty and courage will compensate to some extent for deficiencies in physique. These men must carry out their instructions and duties with care and certainty.

■ 60. EQUIPMENT.—All messengers should be provided with a red brassard and agents should be provided with a blue brassard worn on the left sleeve above the elbow (AR 600-35 and 600-40), and when necessary, with a compass and a message carrying bag. In addition, all except runners and some agents, require some means of transportation. A motor messenger may be the driver of a vehicle or he may be an additional occupant, depending upon the circumstances. Commanders of all units may find it necessary in an emergency to utilize, for messengers, any motor vehicle assigned to their units. An airplane may have solely a messenger mission, it may perform such a mission in addition to its other work, or it may be used only to transport an ordinary messenger. See sections IV and V for the equipment necessary for dropping and picking up messages by airplane.

SECTION II

TRAINING OF PERSONNEL

■ 61. BASIC.—See TM 2260-5 for the minimum training specifications for signal specialists, and particularly those for a basic private, a basic corporal, and a basic sergeant. The training given in the paragraphs below for messengers,

except airplane pilots or observers, follows the completion of the training for a basic private and that for agents follows the completion of the training for a basic corporal or sergeant.

■ 62. **RUNNER.**—The runner will be qualified in—

a. Transmitting oral and written messages.

b. Traveling across country over various kinds of ground at the prescribed rates. (See par. 70.)

c. Using a compass as a means of orientation and as a means of following a given azimuth.

d. Reading maps and orienting himself by stars or sun so as to locate routes, terrain features, and troop positions, and to be able to follow highways, ravines, streams, and telephone or telegraph lines.

e. Selecting routes from map or ground that will furnish the best cover and concealment consistent with time limit of delivery.

f. Observing and reporting troop movements.

g. Recognition of officers, units, ornaments, and insignia with which they are associated.

h. Conveying information and orders by whistle and by arm and hand signals.

i. Using a delivery list and message envelope.

■ 63. **MOUNTED MESSENGER.**—In addition to the training of a runner, a mounted messenger will be qualified in—

a. Feeding, watering, and grooming animals.

b. Saddling and bridling animals, and adjusting their equipment.

c. Care of animals in garrison and field; to include recognition of common ailments, administration of necessary first-aid treatment, and care of back and feet.

d. Equitation, including riding at all gaits over varied terrain.

e. Covering specified distances in specified times, all within the limits of endurance of the animal.

f. Concealing and protecting animals during combat.

■ 64. **BICYCLE, MOTOR, AND MOTORCYCLE MESSENGERS.**—In addition to the training of a runner, bicycle, motor, and

motorcycle messengers will be qualified in riding, driving, and caring for the vehicle which transports them, and in traveling in accordance with traffic regulations and rules of the road.

■ 65. AIRPLANE MESSENGER.—If the airplane messenger is the pilot or observer, he will be qualified in radio and visual communication, and in dropping and picking up messages, all of which are covered elsewhere in this manual. If the airplane messenger is an ordinary messenger being transported by airplane, he should also be trained in the use of a safety belt and parachute.

■ 66. AGENT.—The agent will be qualified in—

- a. Transmitting oral and written messages.
- b. Receiving and transmitting messages accurately by telephone.
- c. Using the message blank
- d. Using the compass.
- e. Reading maps.
- f. Making a simple sketch.
- g. Observing and reporting troop movements, troop positions, and terrain features.
- h. An elementary understanding of the organization and tactical employment of his unit and of the unit to which he is sent.

SECTION III

EMPLOYMENT

■ 67. GENERAL.—For other details as to the employment of messengers, see chapter 2.

■ 68. SELECTION OF TYPE OF MESSENGERS USED.—The effectiveness of messenger communication is largely dependent upon the selection of the proper type of messenger. This selection is based upon the urgency, length or bulk of the message, terrain, weather, and types of messengers and transportation available.

a. *Runner*.—A runner is used when other means of signal communication will not function in a dependable manner, when other means become overtaxed, or when distances are

short or the route is impassable for other messengers. He is able to go where other types cannot go, and he can conceal himself more easily. He should not, however, be used for long distances if it can be avoided.

b. Mounted, bicycle, and motorcycle.—Messages are sent by mounted, bicycle, and motorcycle messengers when the enemy situation and the character of the route permit the use of horses, bicycles, or motorcycles.

c. Motor.—Motor messengers are used between headquarters widely separated, when the mail service will not suffice. They may be placed on a routine schedule or may be subject to call as required.

d. Airplane.—(1) The commander of a division or higher unit may assign airplanes to the messenger service when other means of signal communication will not suffice. Important messages transmitted between widely separated units or between allied armies may best be delivered by airplane.

(2) Messages may be handed on the ground to the pilot, observer, or a messenger traveling in the airplane, or delivered to the airplane in flight by radio, panels, pyrotechnics, pick-up, or other means. (See sec. V.)

(3) Messages transmitted by airplane may be delivered directly by the pilot, observer, or other messenger on the ground or from the airplane in flight by radio, pyrotechnics, or other visual means, or by dropping. (See sec. IV.)

■ 69. RECEIPT OF MESSAGES FOR DELIVERY.—*a.* The officer or noncommissioned officer directing the transmission of a message gives the messenger the following information:

(1) Name and location of the headquarters or person to whom the message is to be delivered.

(2) Route to be followed and dangerous points to be avoided unless left to his discretion.

(3) Speed required.

(4) Whether or not an answer is expected.

(5) Where to report upon return.

(6) Where to report in case the message is not delivered.

(7) Special instructions, if any.

(8) Contents of the message if the situation warrants.

b. When one or more messages are entrusted to a messenger, a delivery list is attached, or he is directed to obtain receipts on the envelope.

c. The messenger is instructed to report his destination to the nearest leader when passing an outpost or other line established by a security detachment. This officer or non-commissioned officer should orient the messenger and lend aid, if required, to expedite the delivery. (See par. 58.)

■ 70. CARRYING MESSAGES.—a. Messages will be carried in the message carrying bag when one is provided. If none is provided, the messages will be carried in the upper left-hand pocket of the blouse or the left-hand pocket of the shirt. Bulky packages are carried in the hand or under the arm. In inclement weather they should be protected by a raincoat or waterproof covering.

b. When the situation permits, messengers will travel by covered routes. When approaching or leaving command posts, messengers will be particularly careful to avoid disclosing the location of the post. They should use such measures as are necessary to insure prompt delivery and to prevent needless exposures. When practicable, routes over difficult terrain which may be traversed at night should be reconnoitered during the day by the messengers who will use them at night. When necessary they will inquire their way of troops they may meet.

c. Messengers will be trained to travel, under good road conditions, at the following prescribed rates given in miles per hour:

	Runner	Mounted messenger	Bicycle messenger	Motor and motorcycle messenger
Routine.....	3	6	6	25
Priority (P).....	5	8	10	40
Urgent (O).....	Highest speed consistent with certainty of arrival.			

d. Messengers may be instructed to show unsealed messages to designated commanders whom they may meet on the route. Each person reading such a message will initial it.

e. The importance of preventing messages of all kinds from falling into enemy hands will be impressed upon all messengers. When in immediate danger of capture, messages will be destroyed. Before destruction, if the circumstances will permit, their contents will be committed to memory.

f. Messengers found wounded or killed will be searched and any message discovered will be delivered to the nearest message center or commander.

■ **71. DELIVERY OF MESSAGES.**—*a.* For routine delivery of messages, see chapter 2.

b. Oral messages should seldom be used on account of the great liability of errors. When used, they should be short and simple. Messengers deliver them verbatim. A messenger receiving an oral message repeats it back to the sender so there may be no misunderstanding. The messenger repeats it to himself until he has committed it to memory.

c. Messengers may at times be required to wait and carry back a reply or other messages destined for their own command. However, their return will not be delayed more than a few minutes for this purpose.

d. When the headquarters, message center, or the individual addressed cannot be found without undue loss of time, messengers will report to the nearest headquarters and request instructions.

e. Messengers whose transportation has become disabled will continue to their destination in the most practicable manner. It may be advisable to report to the nearest headquarters for assistance and instructions. In event of being incapacitated by wounds, they should turn their messages and instructions over to any reliable person whom they may encounter. When such action is necessary they will keep a record of the person, time, and place and turn it in at the first opportunity to the message center or to the person from whom the message was received.

f. Messengers must avoid interfering with marching troops. In the presence of a person not definitely recognized as a member of their own army, messengers will make no mention of the direction from which they have come or of their destination.

g. Messengers will help other means of signal communication to function when it is possible to do so without interfering with their own task. For instance, if they discover breaks in wire lines they will report their location.

■ 72. **DOUBLE MESSENGERS.**—Double messengers should be used when the mission is important or dangerous, such as movement through hostile territory, past enemy patrols, over ground swept by small arms fire, or over heavily shelled areas. Double messengers must keep within sight of each other yet remain separated by such distance as will prevent both being exposed to hostile fire or ambush at the same time. Each should carry a copy of the message. It is sometimes advisable to send messages over several routes at the same time.

■ 73. **ROUTES.**—*a.* Routes over which messengers are to travel usually will be selected by the officer or noncommissioned officer in charge. They must be chosen with due regard to—

- (1) Type of messenger which is to be used.
- (2) Concealment from enemy observation.
- (3) Availability under existing orders or traffic conditions.
- (4) Length and condition.

b. Roads and villages are habitually marked by the engineers to indicate headquarters and routes. When not marked by the engineers, messengers may be ordered to mark them on their first trip over a route, or they may be detailed specially for the purpose. Arrows or other suitable trail marks should be placed at crossroads, at changes of direction, and at frequent intervals along routes to indicate courses to be followed. The marks must be conspicuous.

c. It may be advisable to send messengers over routes once by daylight, preferably with other messengers who have been over the route. Through difficult terrain runners may be instructed to follow telephone wires maintaining their direction at night by letting a wire pass through the hand. Wires may be laid to guide runners at night or through dense woods. Alternate routes are selected whenever the principal route cannot be used because of congestion or enemy observation or shelling.

d. Messengers should be instructed so that they will know the different routes leading to each headquarters or unit to which they may be sent.

■ 74. SCHEDULED MESSENGERS (par. 27f).—When periodic trips are desirable, a scheduled messenger service is arranged by message centers and the necessary assignment of messengers made in accordance therewith. The messenger dispatcher will equalize the work assigned to messengers.

■ 75. RELAY POSTS.—Relay posts may be established when messages must be carried frequently and rapidly between certain headquarters or units widely separated or when a change in the means of transportation en route is necessary. Motorcycle and motor messengers usually do not operate in relays. Relay posts established in enemy territory should be of sufficient strength to provide for their own security.

■ 76. AGENTS.—*a.* Below the division all necessary information can usually be obtained or distributed through reports and field orders, though agents prove useful in special cases. During combat, agents may be exchanged by adjacent platoons or larger units.

b. A headquarters or unit sends out an agent or agents when the service of information, need of coordination, or special occasion requires. They may be used for delivering instructions, for transmitting information, for reconnaissance, and for guides.

c. Agents will be instructed regarding the information which they are to furnish to, and request from, the headquarters or unit to which they are sent. These instructions usually concern the disposition, location, and movement of units, command posts, and headquarters; and the intention, plan, success, and failure of operations. Agents will be given information which may be of value to their respective unit commanders and they will transmit such information as soon as practicable thereafter.

SECTION IV

DROPPED MESSAGES

■ 77. USE.—Dropped messages are normally received by units down to and including the battalion; but by prearrangement, messages may be dropped to any unit, detachment, or individual. During heavy shelling by friendly batteries, dropped messages are usually not sent to units in front of the light artillery positions.

■ 78. DROPPING GROUNDS.—Message dropping grounds or panel display grounds are located near the radio station. Panels are displayed on these grounds when there is a message for the airplane or when the airplane calls for panels. A dropping ground should be an open space removed from high trees, bodies of water, and weeds. (See par. 145.)

■ 79. PROCEDURE.—When an airplane desires to drop a message for a particular unit, it makes a prearranged pyrotechnic or other signal, meaning "display panels" over the unit for which the message is intended. The unit displays its identification panel. The message is then dropped by the airplane as near as possible to the identification panel. On the approach of a friendly airplane, all ground troops observe the airplane for a dropped message. Whether or not prearranged signals are made from the airplane, the message will be picked up by the nearest troops and taken at once to the unit message center or to the commanding officer.

■ 80. EQUIPMENT.—*a.* The message bag and streamer are improvised by air corps personnel, the bag being made of heavy cloth. It is 7½ inches long by 4¼ inches wide. In order to mark for ground troops the line of descent of the bag and its location on the ground, it has two 72-inch streamers, one yellow and one white. Two ounces of sand are placed in one end so that the bag will fall straight to the ground. The bag also contains one-fourth ounce of kapok to keep it afloat if dropped in water. A drawstring or other suitable means is provided for securely fastening the message compartment. Printed on the bag are the words, MAIL OR DELIVER TO THE NEAREST U. S. AIR CORPS TROOPS.

b. Metal tubes are provided by the Air Corps for dropping maps or photographs; these tubes, made of duralumin, are $9\frac{3}{4}$ inches long and $1\frac{3}{8}$ inches in diameter. A chrome-yellow streamer 30 by $3\frac{1}{2}$ inches is attached. The tube is closed by a rubber stopper.

SECTION V

PICK-UP OF MESSAGES

■ 81. USE.—Messages normally are picked up by airplane observers from units down to and including the battalion when the requirements for a pick-up field (par. 82) can be met, but by prearrangement, messages may be picked up from any unit or detachment. This means of message delivery is available to those ground troops equipped with panels; however, by prearrangement, panels may be improvised. The method of pick-up described herein is used when it is desired to pick up messages or other light packages from localities where landing fields are not available. In that case, observation aircraft must carry the equipment required by the observer and a supply of message bags, and ground troops must assemble or improvise the equipment required.

■ 82. PICK-UP FIELD.—An open field is selected 300 yards or more in length with clear approaches up and down wind. There should be no obstacle in the line of flight of the airplane which would keep it from flying close to the ground. The direction of the wind must be carefully noted as the line of flight of the airplane will be into (against) the wind. The degree of success obtained will depend largely upon the selection of the field and the careful lay-out of the equipment.

■ 83. EQUIPMENT.—*a. Required on the ground.*—(1) Two poles, shelter tent, or suitable substitutes, or two rifles with bayonets attached.

(2) Two large nails, about 10-penny. (No nails are needed if shelter tent poles or rifles and bayonets are used.)

(3) Sixty feet of cord about $\frac{1}{16}$ inch in diameter, preferably waxed. If this is not available, any flexible material of equal strength, length, and weight will suffice.

(4) Two panels AL-121, AL-122, or suitable substitutes. These are code and distinguishing panels 12 feet long and 2 feet 4 inches wide.

(5) Two or more message bags.

b. Required in the air.—(1) Fifty feet of waxed braided cotton cord of $\frac{3}{16}$ -inch diameter or equivalent.

(2) A leaded weight of about 2 pounds with four hooks attached to the pick-up end of the cord line.

c. Preparation and arrangement.—(1) The equipment is prepared as follows:

(a) A large nail is driven through each pole about 6 inches from the top so that the nail point will protrude about 2 inches and point up at an angle of about 45°. It is important that the nails be carefully smoothed off so that the cord cannot foul. If rifles with bayonets attached are used in lieu of poles, the hilt of the bayonet is used in the same manner as is prescribed below for the nail. If available, small streamers attached at the top of the poles will aid the pilot in locating the equipment.

(b) The cord is then prepared as follows: A 6-inch loop with a fixed knot is tied in each end of the 60-foot cord in such a manner that about 8 inches of cord is left free from the point where the knot is tied. The message bag is tied to one free end of the cord and an object of equal weight to the other free end. Each message bag and message should weigh about 1 pound. If the weight of the bag and message is less than 1 pound, some foreign substance of small volume should be added to make up the weight. This weight, however, should not be exceeded.

(2) Figure 1 shows the arrangement of the equipment. Each of the loops in the cord is placed over one of the nails. The poles are held upright and the cord pulled taut and in such manner that the points of the nails point into (against) the wind.

(3) The panels are now laid out, one extending from the base of each pole in the direction toward which the wind is blowing. These panels assist in marking the position for the pilot.

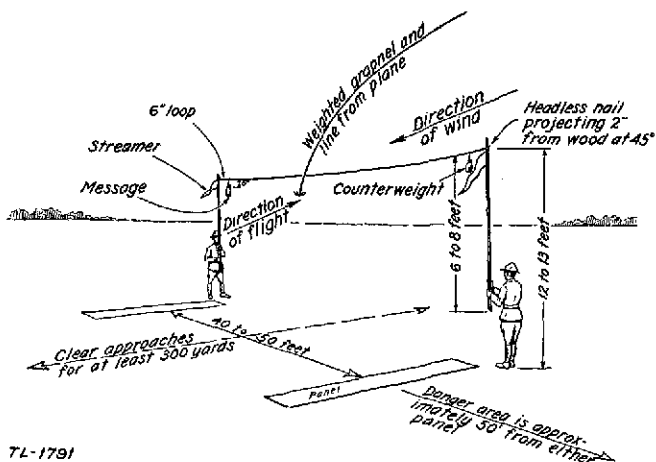

7L-1791

FIGURE 1.—Arrangement of equipment for picking up messages by airplane.

■ 84. PROCEDURE.—*a.* Upon receipt of the panel or other signal meaning "Pick up message at this point", the airplane is flown over and circles the area until the pilot observes that the arrangements are in readiness. When all is ready, the observer lowers the weighted line. When all but a few feet of the line has been released, the observer grasps a bight of the line *without wrapping it around his hand or otherwise securing it to his body*. The airplane then approaches against the wind with the weight trailing on the end of the line and will pick up the cord with the message attached by catching the cord with the weighted line. The line is then pulled into the airplane and the message is removed. The ground detail immediately takes up the panel signal. It is the duty of the observer to assist the pilot in making an accurate pick-up; he should therefore be alert, as the airplane approaches the cord, to lengthen or shorten his hand line so that the weight will strike below the cord. The observer will take every precaution possible to prevent the weighted line from striking ground personnel. All person-

nel not engaged in holding poles should stand to one side at least 50 feet clear of the held poles.

b. More than one attempt may be necessary before the message is successfully picked up. If an attempt is unsuccessful, the ground detail prepares for another trial. The panel signal meaning "Pick up message at this point" will not be displayed until all is ready for the next attempt.

c. All members of the ground detail should watch the approaching airplane and especially the weight on the end of the line. Since it is difficult for the pilot to control the path of the line and weight exactly, the ground men should be alert to avoid being struck by the weight and also to prevent the fouling of the line with the poles.

■ 85. TRAINING.—In preparing yearly training programs, provision should be made where practicable for training in picking up messages. In order to impress on all personnel the possibility of the use of this means of signal communication without standard issue equipment, the ground troops should be required to improvise entirely the equipment required, utilizing for the purpose organizational equipment, personal equipment, and clothing, or articles obtained locally. For example, two small trees might be used for poles, stubs or branches being utilized in lieu of nails, undershirts might serve as panels, handkerchiefs as streamers, an old rag for a message bag, and unraveled shelter tent ropes for cord.

CHAPTER 4

PIGEON COMMUNICATION

■ 86. EMPLOYMENT.—*a. Powers and limitations.*—(1) The employment of homing pigeons as message carriers is based upon the homing instinct of these birds. A trained homing pigeon will return to its loft from a distant point, carrying any light message which has been properly attached to it. Between the point of release and its loft it is an excellent and rapid means of signal communication. Its average speed in clear weather is from a half to three-quarters of a mile per minute. Snow, fog, rain, or gas interfere with its flight. It is little vulnerable; the loss in combat due to killed, wounded, or strayed pigeons is very small. It is a one-way means of signal communication. Homing pigeons are not adapted to night flying unless specially trained for that purpose.

(2) Pigeon communication should be considered as an emergency means of signal communication, as in the case of a unit deprived of other means of communication with its superior unit. (See par. 20c (5).) Transmission of a message by pigeon from a front-line company or battalion to the next superior unit is indirect and correspondingly slow, since the loft is usually located out of hostile light-artillery range.

b. Organization.—A pigeon company is a part of each field army. It includes a breeding and training section with one or more fixed lofts and eight combat sections, each of which is equipped with two mobile lofts. Fixed lofts are employed as breeding and training lofts to furnish birds to mobile lofts. Combat sections are assigned to corps and elsewhere as needed. From these combat sections individual mobile lofts may be detached and stationed as far forward as divisions. The necessary trained personnel accompanies each loft. (For further details, see Signal Corps Field Manual.)

c. Training and settling pigeons.—Each time a loft is moved the pigeons require a period of several days, sometimes as much as 2 weeks, to become accustomed to returning to the new location. The longer the loft remains in one position, the greater the distance over which reliable pigeon communication can be expected. Well-trained pigeons, thoroughly accustomed to the location of their loft, can cover a distance of 60 miles without difficulty. (For further details, see Signal Corps Field Manual.)

d. Mobile lofts.—A mobile loft is stationed conveniently to the principal command post it serves. A loft may serve more than one command post. If it is impracticable for a loft to be located in the immediate vicinity of the command post, messages received at the loft are transmitted therefrom by telephone or other means. During movement, continuous pigeon communication may be provided to tactical units by leapfrogging the lofts, providing there are sufficient lofts and time for settling them.

e. Pigeon posts.—Pigeon posts are normally provided with from two to eight birds. The birds are carried in baskets suitable to the transportation available. Pigeons are assigned to tactical units as needed. The personnel for a pigeon post is furnished by the unit which the post serves. In battalions and larger units pigeons are usually handled by message center personnel whose training should include instruction in their use.

■ 87. DELIVERY, CARE, AND USE OF PIGEONS.—*a. Delivery.*—Arrangements for the delivery of pigeons to pigeon posts of a division are made by the division signal officer. When delivered, they are accompanied by—

(1) Baskets of the proper number and size for the number of birds delivered and suitable for the purpose for which required. (See par. 88.)

(2) Water container for each basket,

(3) Feed.

(4) Message holder attached to each bird.

(5) Gas bag for each basket, if available and required.

(6) Ratproof cage for each basket, if available and required.

b. Care.—(1) When pigeons are received, they should be placed and kept in a dry place protected from rain, dampness, wind, and drafts. Special care should be taken to prevent the feathers becoming muddy and caked as the flight would thereby be greatly retarded. The birds should be protected from rats, cats, and other animals. If ratproof cages are supplied, the baskets should be placed in them. The pigeons should be handled gently and care should be taken that they are not unnecessarily annoyed or excited.

(2) The message holder which is attached to the leg of each bird should not be removed at the pigeon post, but it should be inspected to see that it is loose enough to move freely on the leg.

(3) The only feed given the birds should be that which is received with them from the loft. As damp grain is very injurious to pigeons, care should be taken that this feed is kept dry. Since hunger and the knowledge that food awaits them at the home loft are strong influences for quick flight, it is desirable that pigeons be not fed within 24 hours prior to release. If, however, it becomes necessary to keep the birds at the liberating post more than 24 hours, they should be fed mixed grain twice a day at the rate of a teaspoonful per pigeon per feeding. When early release of a pigeon can be foreseen, the last regular feeding should be omitted.

(4) Fresh water should be offered the pigeons every 6 hours, and also 15 or 20 minutes before release when the time of release can be foreseen.

c. Use.—(1) *Maximum time before release.*—Pigeons should not be kept confined away from their loft for a longer period than 2 days and 3 nights. After the third night, if replacements are obtainable, they should be released, with a message informing the loft of the reason and time of release. If replacements are not obtainable, they may be retained as long as necessary provided feed is available for them. (See par. 88b.)

(2) *Messages.*—(a) Messages to be sent by pigeon are written on thin sheets of paper. These may be the pigeon message sheets of the field message book; cigarette papers may be used in emergencies. The message is folded and placed in the message holder attached to the leg of the bird.

As a precaution against failure to reach the loft, each pigeon should carry, in addition to the new message, a duplicate of the next preceding message sent by pigeon from that post.

(b) Pigeon messages containing information of value to the enemy are normally encoded. (See par. 20c (5).) The pigeon may fall into the hands of the enemy, thus disclosing the contents of the message.

■ 88. TRANSPORTING PIGEONS.—*a.* Pigeons are delivered to the pigeon post in one or more of three types of baskets: PG-8, 4-bird capacity; PG-5, 15-bird capacity; or PG-12, 30-bird capacity.

b. The basket PG-8 is a very small willow wicker or rattan basket which is used by forward pigeon posts. As birds have very little space for movement in this basket they should not normally be kept in it longer than 48 hours.

c. The baskets PG-5 and PG-12 are made of willow wicker or rattan, are lined or partly lined with muslin, and are without interior partitions. They are less confining than the basket PG-8. Therefore, when they are available, birds should be placed in them to permit greater freedom.

■ 89. RELEASING PIGEONS.—To catch the pigeon in its basket, and to release it, proceed as follows:

a. Fold the message compactly in such a manner as to fit the message holder and hold the message between the teeth while catching the bird.

b. Turn the bird so that it faces toward you and force it gently to the side or end of the basket. (See fig. 2.)

c. With the palm against the wing, place the thumb across the bird's back and the fingers under the bird's body, catching its feet between the index and middle fingers as shown in figure 3.

d. Remove the bird head first from the basket. If the basket opening is of sufficient size, use both hands in catching and removing the bird. Always use both hands in holding the bird after removing it from the basket as shown in figure 4.

e. When holding the bird, always keep its breast firmly against your body and the hand in the same position as used

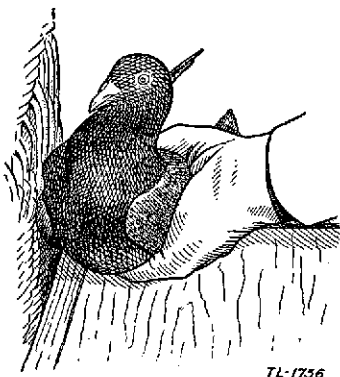

TL-1756

FIGURE 2.—Force the bird gently to the side or end of the basket.

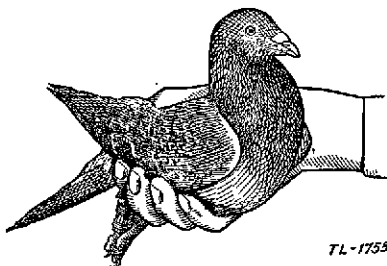

TL-1755

FIGURE 3.—Catch the feet between the index and middle fingers.

in catching it, as shown in figure 5. Hold the bird loosely and, if it is large, or your fingers short, make no attempt to hold both wings with the thumb. As long as the bird is held firmly against the body it cannot escape and any attempt to hold both wings is likely to damage the flight feathers seriously. Do not transfer the bird from one hand to the other.

f. With the bird held in the position as described in *e* above, extend its leg and hold it by applying pressure at the knee joint with ends of the index and middle fingers as shown in figure 5. Remove the upper half of the message holder which is attached to the bird's leg and insert the

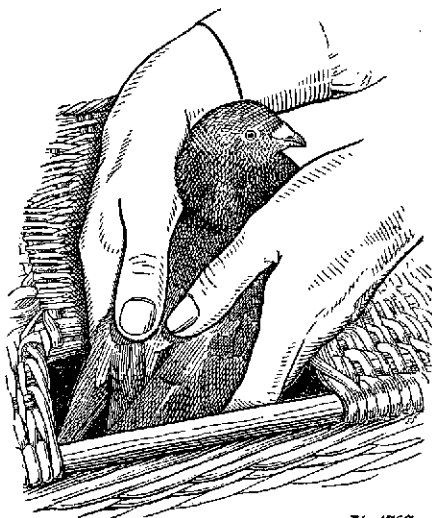

TL-1757

FIGURE 4.—Use both hands if size of basket opening permits.

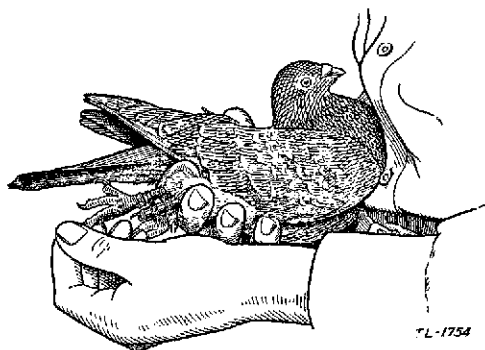

TL-1754

FIGURE 5.—Hold the bird firmly against the body.

folded message therein. Replace the upper half of the holder in the lower half.

g. Always turn the holder so that it rests on the front of the leg; if on the back of the leg the holder interferes with the bird walking and holding its legs up under its tail in flight. See that the holder does not fit tightly but is free to move on the leg.

h. Extend the arm with the hand holding the bird as in *e* above and open the hand.

i. When releasing a bird at night, select an open spot free of wires, trees, and other obstructions, and give it a gentle upward toss as the hand is opened.

CHAPTER 5

RADIO COMMUNICATION

	Paragraphs
SECTION I. General.....	90-97
II. Operating regulations.....	98-107
III. Station records.....	108-111
IV. Tactical radio nets.....	112-118
V. Special procedures.....	119

SECTION I

GENERAL

■ 90. DEFINITIONS.—The terms, as used in this chapter, are defined below. For definitions of other terms, see paragraphs 5 and 13.

a. Break-in operation.—Break-in operation is operation wherein the receiving operator can interrupt the transmitting operator at any time.

b. Call sign.—A call sign is a group of letters, or of letters and numerals, used for station identification.

c. Frequency assignment.—The frequency assignment of a station is the frequency or frequencies, usually expressed in kilocycles (kc) or megacycles (mc), at which the station is authorized to operate. For sets which are calibrated in channels or tuner settings this assignment is made by assigning channels or tuner settings.

d. Heading.—The heading of a message is that part which appears before the text begins. (See JANP.)

e. Intercept station.—An intercept station is a station that copies enemy radio traffic for the purpose of obtaining information or friendly traffic for the purpose of supervision.

f. Internet traffic.—Traffic between stations which are not assigned to the same net is called internet traffic.

g. Linking station.—A linking station is a station used for the relay of messages from one net to another.

h. Mobile station.—A mobile station is a station that normally operates from a stationary location but which can be

rapidly transported to another location. The station may in some cases be operated while in motion.

i. Number.—The numbers defined below should not be confused with the message center number referred to in chapter 2.

(1) *Message serial number.*—A message serial number is a number assigned by an operator to an outgoing message to facilitate handling and checking of traffic. It is never used in the abbreviated form message.

(2) *Writer's number.*—A writer's number is a number which may be given a message by the writer and which is a part of the text.

j. Net call sign.—A net call sign is a call sign used to call all stations in a net.

k. Position finder station.—A position finder station is a station containing one or more radio receivers capable of finding the location from which incoming radio waves are arriving at the receiver.

l. Radiotelegraphy.—Radiotelegraphy is radio communication by means of the International Morse Code.

m. Radiotelephony.—Radiotelephony is radio communication by means of voice signals.

n. Service.—The service of a message consists of the notations made on a message by transmitting and receiving operators.

o. Signal operation instructions.—See paragraph 261.

p. Station log.—A station log is a chronological record of traffic kept at a station.

q. Traffic.—Traffic consists of all transmitted and received messages.

r. Transmission.—A transmission is a complete communication between stations including all queries, repeat-backs, and receipts.

s. Trick or watch.—A trick or watch is a tour of duty as an operator.

t. Vehicular station.—A vehicular station is a station so installed in a vehicle that it is capable of operation with the vehicle in motion.

■ 91. EMPLOYMENT.—*a.* Radio is used as a means of signal communication between all combat units down to and including battalions, squadrons, individual airplanes, and certain vehicles of mechanized units, for liaison and fire control, and for the control of forward combat units to include the company in some situations.

b. Radiotelegraphy is the normal means of radio communication. The International Morse Code is used for radio-telegraphy by the Army and Navy. (See par. 127.)

c. Radiotelephony is limited to special uses such as between airplanes, between airplanes and ground, between vehicles of mechanized units, between ground stations and vehicles, for artillery fire control and liaison, and for control of forward combat units.

d. Radio communication within a tactical unit on the march may be established at prearranged times and places or between vehicular stations accompanying the units and operating while actually on the march.

e. Paragraph 245*a* applies to radio equipment also.

■ 92. POWERS AND LIMITATIONS.—*a.* The range and quality of radio communication are, in general, independent of conditions of roads and traffic, and are affected by the nature of the intervening terrain in a varying degree depending upon the frequency used. Vehicular sets however are affected by conditions of roads and traffic. Weather conditions may have a serious effect on range and quality. (See par. 96.)

b. Radio communication is the most effective means of signal communication between rapidly moving units when the maintenance of wire and messenger communication is impracticable.

c. Radio communication can be readily intercepted by hostile stations. This disadvantage necessitates the habitual encoding of messages when transmitted by radio. (See par. 43.)

d. The approximate number, types, and locations of our radio stations can be determined by hostile position finder stations. From this information the enemy can estimate the

disposition and approximate strength of our forces. This disadvantage of radio communication can be minimized by—

(1) Curtailing the use of radio during the times this information would be of most value to the enemy.

(2) Establishing dummy stations to cause errors in his deductions.

e. Hostile radio stations can interfere deliberately with our radio communication by blocking a single frequency or band of frequencies and by deception, that is, causing our stations to accept false or erroneous information and messages. The effects of interference can be minimized by—

(1) Training radio operators in the strict observance of radio discipline and radio security.

(2) The use of prearranged signals or groups of letters preceding each transmission to identify the station making the transmission.

(3) Frequent changes and limited use of call signs.

(4) Limiting the number of stations in a net.

■ 93. RADIO NETS AND NET CONTROL STATIONS.—*a. Nets.*—See also section IV. In order that radio communication may follow the proper channels of tactical command, the radio station of a superior unit and the radio stations of the next subordinate units are grouped together for operation. This group is called a radio net. To insure a smooth flow of message traffic in a net it should contain not more than five stations. (See fig. 6.)

b. Net control stations.—The operation of radio nets must conform to tactical conditions. Stations must move with the headquarters of their units in order that the net may serve promptly the will of the commander. Centralized control and net discipline are therefore required. (See pars. 113 and 114 for further details.)

■ 94. ASSIGNMENT OF FREQUENCIES AND CALL SIGNS.—*a.* Radio nets must operate on assigned frequencies to prevent interference with each other. Each radio net is assigned certain definite frequencies on which to operate. These frequencies are normally allotted by GHQ and assigned to units through army, corps, and division headquarters.

b. Call signs are assigned in the same manner as frequencies.

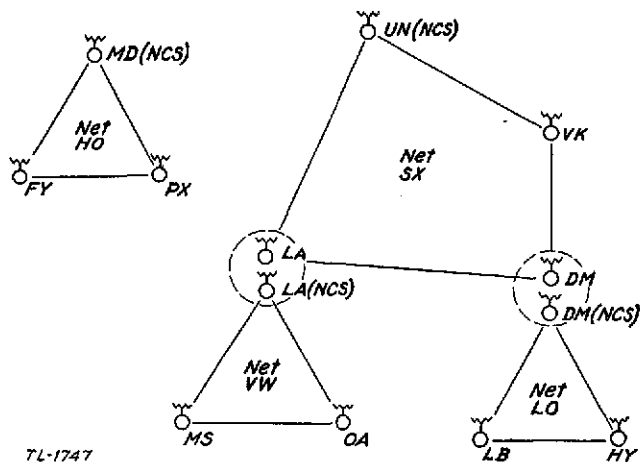

FIGURE 6.—Tactical radio nets.

c. Assignments of call signs and frequencies are issued in the form of signal operation instructions. (See page 283 and facing page 284 for examples.)

d. Changes in assignment of call signs and frequencies may be expected by radio nets in the combat zone. These changes will be made at intervals which may vary in length from 24 hours to several days and are made for purposes of signal security.

e. The use of any call sign or frequency not assigned by higher headquarters is prohibited.

■ 95. TRAINING OF RADIO OPERATORS.—See TM 2260-5.

■ 96. LOCATION OF STATIONS.—a. The following considerations are important in the location of radio stations:

(1) Stations should be in quiet localities, protected from moisture and from enemy fire. The copying of weak signals requires great concentration by the operator. Therefore, noise and confusion in the vicinity of stations should be minimized.

(2) Stations should be placed at a distance from any source of radio interference. Sources of possible interference

are power lines, telegraph and telephone lines, and electrical equipment of any sort, including nearby radio stations.

b. Radio waves, especially those of very high frequencies, may be screened by intervening objects such as high hills, wooded areas, large structures of reinforced concrete and steel, and pole lines carrying conductors. To minimize the effect of such screening, the radio station should have its antenna located in the clear and elevated when practicable. (See par. 92a.)

■ 97. SPECIAL USES OF RADIO.—a. Radio is used in the military service for numerous special purposes, among which are—

(1) *Reception*.—(a) Location of enemy radio stations on land, ships, or aircraft.

(b) Interception of hostile radio traffic.

(c) Interception of friendly radio traffic for supervisory purposes.

(d) Collection of upper air meteorological data from balloons, airplanes, or airships.

(2) *Transmission*.—(a) Meteorological information.

(b) Time signals.

(c) Press reports.

(d) Propaganda.

b. These special services are operated and maintained by the signal troops of the higher units, usually the army.

c. Copying of press reports is a function of the army signal service which in turn rebroadcasts to the lower units.

d. Meteorological information is normally broadcast at fixed hours for the information of units concerned.

SECTION II

OPERATING REGULATIONS

■ 98. GENERAL.—a. *Technical Regulations*.—See paragraph 4a (1).

b. *Instruction books*.—The technical operation of some radio sets is covered in instruction books prior to the publication of Technical Regulations for those sets. When these instruction books are published, one or more copies are issued with the sets as parts thereof.

■ 99. PROCEDURE AND PROCEDURE SIGNALS.—*a. Defined.*—(1) *Radio procedure* is a standardized routine used by radio operators in the handling of traffic.

(2) *Procedure signals* are nonsecret, arbitrary signals which have been adopted to assist operators in handling traffic in the shortest possible time. Hereinafter the term procedure signals will be used to include the terms *procedure signs* and *procedure signals* defined in JANP.

b. How prescribed.—(1) To insure a standard operating procedure or routine for the military and naval services, the *Joint Army and Navy Radiotelegraph and Radiotelephone Procedure (JANP)*, approved by the Secretaries of War and Navy, is issued for the guidance of the Army and Navy personnel concerned. The JANP is distributed to the Army by The Adjutant General.

(2) Strict compliance with the JANP and any supplemental regulations relative to operating procedure insures the accurate and rapid handling of traffic with minimum transmissions. Every radio operator must have a thorough knowledge of the correct procedure to use in any particular case. Deviation from authorized procedure usually results in delaying traffic and is prohibited. Certain short cuts in procedure to speed up traffic under special conditions are specifically authorized in the JANP.

c. For special procedures, see section V.

■ 100. CODES AND CIPHERS.—Several types of codes and ciphers are used for encoding messages. (See pars. 5a, 47, and 48.) A partial list of the various message codes and ciphers with their indicators and the number of characters comprising each code group is shown below. Indicators of codes authorized for training include the letter T before the number. For example, DFC-T1 is the indicator for the training issue of the Division Field Code. Similarly, those authorized for use in maneuvers include the letter M. For example, AGL-M1 is the indicator for the maneuver issue of the Air-Ground Liaison Code.

Name of code or cipher	Indicator	Number of characters per group
The War Department Telegraph Code.	WTC.....	5
The Division Field Code.....	DFC, followed by a number.....	4
The Fire-Control Code.....	FCC, followed by a number.....	2
The Air-Ground Liaison Code.....	AGL, followed by a number.....	3
The Meteorological Code.....	M, followed by two letters.....	4, 5, 6, or 7
Cipher device M-94.....	OD.....	5

■ 101. TRANSMITTING RULES.—*a.* An operator will listen on the transmitting frequency assigned his station before making any call or other transmission. If there are other stations working on the frequency he will not interrupt communication unless such interruption is warranted by the class of his traffic. (See JANP.)

b. All transmissions must be as short and concise as possible. No superfluous calls or signals of any kind will be sent. An operator may test his transmitting set before the first transmission by sending a few "V's" followed by his own station call sign.

c. Messages and transmissions must be sent at a speed which will allow the receiving stations to copy them on the first transmission. Thus no transmissions should be faster than the slowest operator in a net can receive them.

d. Particular care is necessary that all call signs are made slowly and distinctly.

e. The procedure sign for "wait" is used when an immediate answer cannot be given.

f. An "end of message" sign will always be used.

■ 102. TRANSMISSIONS.—*a.* A radio station will transmit only those messages authorized by competent authority. All transmissions and messages handled will be considered as official. (See pars. 27*b* and 35*a* (4).)

b. At times there is need for certain inquiries, instructions, and information in connection with the handling of traffic. In general, this need is adequately met by the prescribed procedure signals. When procedure signals cannot be used a message will be employed. The exchange of transmissions in other than authorized form is prohibited.

c. The chief operator or station chief of a station has full authority to authorize the transmission of messages relating to the signal service. Such messages will be signed with the call sign of the station of origin, and will be in an approved code.

d. Every operator will read through the text of each message filed to ascertain that each word or the individual letters of each code group are clear and unmistakable. If there is any doubt about any of the words or letters he will have them verified.

■ 103. TIME ENTRIES AND THE RADIO DAY.—Unless otherwise specified by higher authority—

a. Time entries on the station records are made in the time of the zone in which the station is located.

b. Transmissions involving the specifying of time (time broadcasts, transmissions as to the time a station will call another station or return to a net, etc.) likewise use the time of the zone in which the station is located.

c. The *radio day* is the 24-hour period covered by a complete set of station records. It commences at midnight of the time zone in which the station is located, and ends at the following midnight of the same zone. All station records of all stations in the net will be opened and closed in accordance with the above-mentioned rule.

■ 104. COOPERATION WITH THE MESSAGE CENTER.—a. The message center at each headquarters is the agency charged with the receipt, transmission, and delivery of messages. (See ch. 2.) The message center is also charged with the encoding and decoding of messages when required. It is therefore essential for radio station chiefs to keep the message center informed at all times of the stations actually operating in the net and of traffic conditions with reference to any delay time that might occur to messages routed by radio.

b. Any messages that cannot be sent without delay should be returned to the message center for routing by other means. Failure by radio station personnel to cooperate fully with the message center or other traffic routing agencies that may be prescribed will result in serious delays in the delivery

of messages and in much useless code work by the message center personnel.

■ 105. RECEPTION.—*a.* All received messages are copied at the radio station in duplicate. Messages are copied on the typewriter or by hand using the system of lettering described in paragraph 42. When copied by hand, five code groups will constitute a line. In using the typewriter, five or ten code groups will constitute a line.

b. See paragraphs 28*a* and 35*b* for the disposition of the original and the duplicate copy of incoming messages. To delay original copies of messages for recopying or extracting data for station records is prohibited.

c. See paragraphs 30 and 35*c* for the disposition of the original and the duplicate copy of relay messages.

■ 106. OPERATOR'S PERSONAL SIGN.—Each operator is identified by a personal sign of one or two letters. No two operators in the same station will use the same sign. The personal sign of an operator is never transmitted but is used only in connection with the keeping of station records.

■ 107. SERVICING OF MESSAGES.—*a.* Every message is serviced by the transmitting operator and the receiving operator upon the completion of its transmission. The transmission of a message requiring a receipt or a repeat back is not considered complete until such receipt or repeat back is received by the transmitting operator.

b. The operator's service is written in at the bottom of the message. Many operators perform this service with one hand while operating the key with the other. This service consists of the time transmission of the message is completed, and the personal sign of the operator. For example, 956A JM.

c. A transmitted message must show the station to which it was sent and a received message must show the station from which it was received. In any case where this information is absent from the heading of the message the operator's service will include it.

SECTION III

STATION RECORDS

■ 108. OPERATOR'S NUMBER SHEET.—Stations that are required by the JANP to use message serial numbers on messages will keep a record of these numbers in the following manner:

a. On the completion of the transmission or reception of a normal form message, each key operator concerned will draw a line through the number of the message sent or received, on the number sheet, in the column assigned to the other station involved and enter the time of receipt and his personal sign in the blank column to the right.

b. The following example indicates a completed extract of a satisfactory number sheet for recording message serial numbers:

OPERATOR'S NUMBER SHEET

Check off both sent and received numbers immediately and enter time and personal sign. Numbers must be exchanged nightly at closing hour. Receiving and sending operators will be held responsible for correct records of numbers.

STATION LA CIRCUIT OR NET 9TH INF DATE 6 JUNE

MS		OA			
SENT	RECEIVED	SENT	RECEIVED	SENT	RECEIVED
1 816A/LC	1	1	820A/LC	1	1
2	2	2	961A/LC	2	2
3	3 832A/LC	3	960A/LC	3	3
4	4 900A/LC	4		4	4
5 902A/LC	5	5		5	5
6	6	6	1010A/LC	6	6
7 1082A/JY	7	7	1021A/LC	7	7
8	8	8		8	8
9	9	9	1040A/JY	9	9
0	0	0	1102A/JY	0	0
1	1 918A/LC	1	1052A/JY	1	1
2	2 1031A/JY	2		2	2
3	3	3	1115A/JY	3	3
4	4	4		4	4
5 1121A/JY	5	5		5	5
6	6	6		6	6
7	7	7		7	7

■ 109. STATION LOG.—*a. General.*—(1) A station log in conjunction with the number sheet and the file of transmitted and received messages forms a complete record of events and operating conditions which occur during a radio day at a station.

(2) The amount of detail that should appear upon the log varies according to the number of operators on duty at the station, and the state of training of the operators.

(3) In any case the keeping of the log should not operate to delay traffic.

(4) Signal and communication officers are authorized to prescribe the amount of detail that they require on the logs of their stations but the following essential elements with time entry for each will be included:

(a) Operators on duty.

(b) Opening and closing of stations.

(c) Causes of delays in traffic.

(d) Frequency adjustments and changes.

(e) Unusual occurrences such as procedure violations, verifications, etc.

(5) During the initial training phases the log should include all signals heard or transmitted, thus serving as a detailed check on operating procedures. As training progresses the amount of detail required can be gradually reduced to the essential elements listed in (4) above.

b. Form and example.—(1) *Training form.*—The following is a satisfactory station log form for use during the initial training period and for stations having a senior (key) and a junior (log) operator. A form of this kind is desirable when actual transmissions are to be logged in detail.

SIGNAL COMMUNICATION

109

STATION LOG

Date_____ 19____ Net_____ Sheet No. ____
 Station call_____ Net call_____ Station opened_____ M
 _____ Senior operator _____ Junior operator

Time	To	From	Traffic

(2) *Example of log.*—During the later training period and in actual field operations a combination form having the operator's number sheet printed on one side and a log printed on the reverse side is more satisfactory. The operator merely turns his number sheet over and makes the log entry on the back thereof as the events requiring a log entry occur. The following is an example including entries of such a form in common use at fixed stations. This form is printed on the reverse side of the operator's number sheet shown in paragraph 108.

Log

Enter opening and closing times, frequencies and frequency changes, traffic delays, and any incidents or conditions affecting circuit efficiency.

STATION LA CIRCUIT OR NET 9TH INF DATE 6 JUNE

Time	Operator	Remarks
802A	LC JY	STATION OPENED AT CEDARFALLS 4100 KC.
816	-----	MS AND OA IN NET.
921	-----	CLOSED STATION FOR MOVE.
945	-----	REOPENED AT MILLBROOK OA OUT.
950	-----	OA IN NET CHECKED FREQ.
1030	JY LC	JY TO KEY LC TO GENERATOR.
1055	-----	MS DID NOT ANSWER CALL.
1110	-----	MS BACK IN NET WITH REPAIRED GENERATOR CORD.
1130	OS HU	RELIEVED JY LC.
1152	-----	NET SILENCED.
220P	-----	CLOSED STATION AFTER TRAFFIC CHECK BY PHONE.

■ 110. DISPOSITION.—*a.* The station log, number sheets, and any other records connected with the operation of a station for a radio day will be placed together in a packet as soon as possible after the conclusion of such period and plainly marked with the date and a description of contents. These records will be disposed of as prescribed by the unit signal or communication officer.

b. Radio station records often contain valuable information for the enemy intelligence service. If at any time there is great danger of station records being captured by the enemy, they will be destroyed.

■ 111. IMPORTANCE.—*a.* Station records are valuable studies for signal and communication officers to use in determining errors made by operating personnel, causes of delays in traffic, and in determining the proper actions necessary for increasing traffic efficiency. They are also useful in the recovery of lost messages and as verification records.

b. The keeping of these records is secondary to the primary mission of delivering the message to the addressee without delay and exactly as written by the writer. Operators should be constantly reminded of their primary mission.

SECTION IV

TACTICAL RADIO NETS

■ 112. GENERAL.—*a.* Tactical nets are made up of mobile or vehicular low-power radio stations of tactical units in the field. Tactical nets are given a name indicative of the superior headquarters in the net, that is, the GHQ net, the First Army net, the II Corps net, the 3d Division net, the 4th Field Artillery Brigade net, etc. (See par. 93.)

b. Nets operate either on schedule or continually (continuous watch). Nets operating on schedule handle traffic only at definite, prearranged times and in accordance with a prearranged schedule of intercommunication. Nets operating continually are prepared to handle traffic at any time; they maintain operators on duty at all stations in the net at all times. When practicable, messages relating to schedules will be transmitted by a means of signal communication other than radio.

c. All stations in a net normally operate on the same frequency.

d. A separate frequency for each station in a net is required when duplex operation is used, that is, when each station is transmitting and receiving simultaneously.

■ 113. CONTROL.—a. In every net one of the stations is designated as the net control station, abbreviated NCS. The NCS is charged with the clearing of traffic within the net, with dispatching internet traffic as quickly as possible, and with maintaining order within the net. Questions concerning traffic are referred to the NCS for decision. The authority of the NCS extends only to the operation of the net on the air, and is in no way concerned with the interior administration of any station, nor with its tactical operation or movement. Within its scope, however, the authority of the NCS is absolute, its decisions are final, and its orders are strictly obeyed. These orders are generally transmitted in the form of procedure signals, or messages, but may be contained in written orders, circulars, or letters of instruction. (See par. 93.)

b. Duty as NCS is generally assigned to the station of the superior headquarters in the net, but may be assigned to any station in the net which can best fulfill the duties. All other stations in the net are known as secondary stations and are under control of the NCS.

c. A secondary station is always designated by the NCS to take over the functions of the NCS if the NCS leaves the net for any reason. This station is called NC2.

■ 114. OPERATION.—a. A net may be operated as—

(1) A *free net*, in which any station can communicate with any other station in the same net without first obtaining permission to do so from the NCS.

(2) A *directed net*, in which case no station, except the NCS, can communicate, except for the transmission of urgent messages, with any other station without first obtaining the permission of the NCS. Permission granted to a station to transmit one or more messages covers all communication necessary to complete the transmission of such messages.

b. Nets ordinarily are operated free, but the NCS may change to directed net operation at any time if it is unable otherwise to maintain proper control. In a directed net, traffic moves more slowly than in a free net. A directed net should be used only when all other means of obtaining order have failed. Free net operation is resumed in all cases as soon as the necessity for directed net operation has passed.

c. A secondary station always informs the NCS promptly when it knows it will be unable to follow out its schedules, or unable to have its station on continuous watch at any time during which a continuous watch is to be maintained. (See par. 112*b*.)

■ 115. TRANSMISSION IN CODE AND IN CLEAR.—Normally all messages transmitted are encoded. Under certain conditions transmission of messages in the clear may be authorized by a commander. (See par. 43.)

■ 116. TRAFFIC.—*a*. Nets must be prepared to assume the entire traffic load of their units at any time. For this reason close cooperation with the message center is essential. Radio stations are given a telephone connection whenever practicable.

b. A communication will not be interrupted until completed except to transmit urgent traffic. (See par. 15*c*.) All stations remain silent for a period of 15 seconds at the completion of each message transmitted, in order to permit any station in the net to send urgent traffic. Transmitting operators interrupt communications of a lower class for the transmission of urgent traffic. When stations are using the break-in system of operation, communications of lower class are interrupted by the receiving operators for the transmission of urgent traffic.

c. Urgent messages are transmitted to the station of destination, or to a linking station, as soon as possible, under the restriction imposed in *b* above, without in any case obtaining permission from an NCS. If such traffic is for a station in another net, the operator reports back into his own net upon completion of his internet communication.

■ 117. ESTABLISHING A NET.—*a*. During the concentration period, station call signs, net call signs, duties, and frequen-

cies are assigned to the various stations and nets. When time permits, sets in the net should be calibrated prior to the opening of the action.

b. Radio stations conform to the movements of the organizations served. As soon as a station is set up and in operation at the desired location it endeavors to report into the net of which it is a part.

c. The first station set up acts as NCS and the second station as NC2 until the regularly appointed NCS reports into the net and takes control. The NCS, when necessary, causes each new station reporting into the net to adjust its frequency until all stations can be heard on the same dial setting of the receiver of the NCS. The NCS may adjust its frequency in accordance with directions from one of the secondary stations until that station receives the NCS and all other stations in the net on the same dial setting. This adjustment of net frequency is made when the third station reports into the net and each station reporting thereafter with an incorrect adjustment is caused to adjust its frequency before it transmits any traffic. The NC2 takes over the duties of the NCS in case the NCS disappears from the net or leaves the net without giving other instructions.

d. Procedure signals are provided in the JANP to cover the above operations.

■ 118. INTERNET TRAFFIC.—*a. Necessity for.*—Figure 6 is used in connection with examples of internet traffic and the handling of messages which must be relayed. It may be considered as representing a system of tactical nets. It should be noted that the nets SX and VW and the nets SX and LO are linked physically by having two stations at a common headquarters, while the net HO is physically isolated. Consequently, while a message originating in the net LO with destination in the net VW could be handled either by relay through the net SX or by direct internet communication, all traffic to or from the net HO must be handled by internet communication.

b. How accomplished.—In cases of internet communication, except for the transmission of urgent messages, the station obtains permission from its own NCS to leave the

net, stating with what station it is going to work, and reports to the NCS of the new net before transmitting any traffic in that net. A station reports back into its own net as soon as its business is finished in the outside net. In case the station does not know the call sign of the net or of the NCS, or the frequency to be used, it obtains such information by means other than radio, if practicable. The only exception to the rule above is in case of an urgent message, in which case a station will get the message through with a minimum of transmission; that is, a direct call up if practicable.

SECTION V

SPECIAL PROCEDURES

■ 119. GENERAL.—*a.* In modern Army and Navy operations special radio procedures are necessary or may become necessary. Such procedures, if used, will not conflict with the provisions of the JANP. Special procedures are usually designed for economy of time and may employ special codes.

b. Examples of such procedures are those used for—

- (1) Artillery fire control.
- (2) Command nets of mechanized units.
- (3) Control of forward combat units.

c. These procedures are not included in this manual for the reason that they are usually brief, are incorporated with the code to be used for the special purpose, and may be revised frequently.

CHAPTER 6

VISUAL COMMUNICATION

	Paragraphs
SECTION I. General	120-121
II. Lamps	122-129
III. Flags	130-135
IV. Pyrotechnics	136-141
V. Panels	142-155
VI. Airplanes	156

SECTION I

GENERAL

■ 120. SCOPE.—Visual communication includes all signals received by the eye regardless of how they may have been transmitted. While arm and hand signals are properly a part of visual communication, they are not covered in this manual but are prescribed in other training publications. Thus, in this manual visual communication includes only communication by lamps, flags, pyrotechnics, panels, and airplanes.

■ 121. POSSIBILITIES AND EMPLOYMENT.—*a. General.*—In general, visual communication is an auxiliary means supplementing wire and radio, but the necessary equipment issued for its use should always be at hand and in operative condition if, due to the failure of other means, the condition necessitating and favoring its employment should arise. Its use depends upon the character of the warfare, the proximity of the enemy, the character of the terrain, and the weather. It is unsuited for the transmission of long messages but is well suited for transmitting prearranged signals, short code groups, and brief messages from front to rear and from ground to air. Such messages include firing data from the observation posts of the Field Artillery to the guns prior to the establishment of wire communication, requests for artillery support, ammunition, and reinforcements, signaling arrival of troops at certain important locations, and instruc-

tions to infantry liaison and artillery adjustment airplanes. The success of visual communication depends upon previous preparations for its use. Among preparations to be made are the careful training of the visual operators, the preparation and distribution of codes and prearranged signals, and the selection of present and future locations for the visual stations of advancing units.

b. Between ground stations.—(1) *Making contact.*—All prominent points within signaling distance should be examined frequently by visual operators to see if visual communication is being attempted therefrom. Attempts to attract attention of a visual signaling station with which communication is desired must be persistent. The azimuths of all other stations with which visual communication is to be established should be measured and recorded. Pairs of stakes, separated by several yards and tagged with the designation of the station to which they aline, should be driven into the ground.

(2) *Limitations.*—Visual communication should not be used when it is likely to disclose a position, to draw fire on other troops, or where signals being sent may be read by the enemy. Great care must be exercised in the selection of locations for visual signaling stations, especially those transmitting from rear to front. These considerations therefore frequently preclude two-way visual communication. When not in immediate contact with the enemy, visual stations may communicate in any direction, furnishing a simple and readily available means of communication, but when in immediate contact with the enemy, visual communication will generally be employed only from front to rear, although two-way lateral communication may be employed if both stations are defiladed from hostile view.

(3) *Advantages.*—The advantages of visual communication between ground stations are—

(a) Rapidity with which stations can be installed.

(b) Speed with which short messages and prearranged signals may be sent.

(c) The light weight, simplicity, and portability of the equipment.

(d) Absence of need for metallic circuits between stations.

(e) Messages may be sent in the clear when the transmitting station cannot be seen by the enemy.

(4) *Disadvantages.*—The disadvantages of visual communication between ground stations are—

(a) Impracticability of sending long messages.

(b) Its limited range.

(c) Its dependence on weather and terrain.

(d) The difficulty of locating stations with which communication is desired.

(e) The constant vigilance necessary on the part of visual operators to avoid missing signals for the stations they operate.

c. Between ground and air.—(1) *How carried on.*—Visual communication from ground to airplanes in flight is carried on by use of panels and pyrotechnics. (See secs. IV and V.) The airplane may reply by radio, dropped message, motor signals (sound), pyrotechnics, or wing signals, all of which are covered elsewhere in this manual.

(2) *Advantages.*—The advantages of visual communication between ground and air are the same as those listed in b (3) (a), (b), and (c) above.

(3) *Disadvantages.*—The disadvantages of visual communication between ground and air are—

(a) Impracticability of sending long messages.

(b) Its dependence on weather and terrain.

(c) Difficulty of the air observer in locating stations with which communication is desired.

(d) Ease with which hostile aircraft can locate ground stations.

SECTION II

LAMPS

■ 122. *EQUIPMENT.*—*a.* Signal lamp equipments EE-6, EE-6-A, EE-10-B, and EE-84 are authorized for specified field artillery and coast artillery units. Signal lamp equipment EE-80 is a portable searchlight 12 inches in diameter mounted on a tripod. It is normally placed in airdrome control towers and used for signaling to airplanes.

b. The EE-6 and EE-6-A are essentially the same, the difference being that the EE-6-A includes a belt with an

attached case and a control box for carrying the eight dry batteries, spare bulbs, and key, while in the EE-6 these items are carried in one case which is rested on the ground during operation. Basically, both consist of a portable electric lamp similar to an automobile headlight with a metal reflector 14 centimeters (about 5½ inches) in diameter, a sighting tube on the top, a hinged lid covering the open front, and a 2-wire cord to connect the batteries to the lamp. Signaling with all types of lamps is accomplished by operating the key and causing short or long flashes of the lamp. These flashes are combined into the characters of the International Morse Code. (See par. 127.)

c. The EE-10-B uses either a 6-volt alternating current supply obtained through a 110-volt step-down transformer or a 6-volt battery supply. It is heavier and more rugged than the EE-6 and has a 6-inch silvered glass reflector. Power supply, key, and controls are built into the wooden carrying case for the lamp. A 2-wire cord connects the lamp to its power supply and key.

d. The EE-84 uses a silvered glass reflector 4½ inches in diameter and a prefocused 6-volt automobile-type bulb. On top of the lamp is a telescopic sight for directing the light beam. The lamp is mounted on trunnions equipped with an elevating mechanism. This assembly is mounted on a standard aiming-circle tripod complete with leveling bubble, azimuth and micrometer scales, and compass for laying the lamp from the map. A metal box containing dry batteries and a relay is connected to the lamp by a 4-foot, 2-wire cord. The key is connected to this box by a longer 2-wire cord and hence may be located some distance from the lamp.

■ 123. ADJUSTMENT.—The reflecting apparatus of all lamps should be checked for adjustment at frequent intervals and each time a bulb is replaced. To adjust the EE-6, draw horizontal and vertical lines on a flat vertical background such as a wall, with their intersection at the height of the center of the reflector above the ground. (See fig. 7.) Locate a sighting point on the vertical line at a distance above this intersection equal to the distance between the

centers of the reflector and the sighting tube. Set the lamp up a few yards away and aim the sighting tube at the sighting point. Turn the screws supporting the reflector until the light spot on the wall becomes centered at the intersection of the horizontal and vertical lines and is concentrated in the smallest possible circle. A similar procedure may be followed in adjusting other lamps. When properly adjusted, the lamp projects a beam of approximately parallel light rays. The more accurately this adjustment is made, the more restricted becomes the area in which signals may be observed and the greater becomes the transmission range.

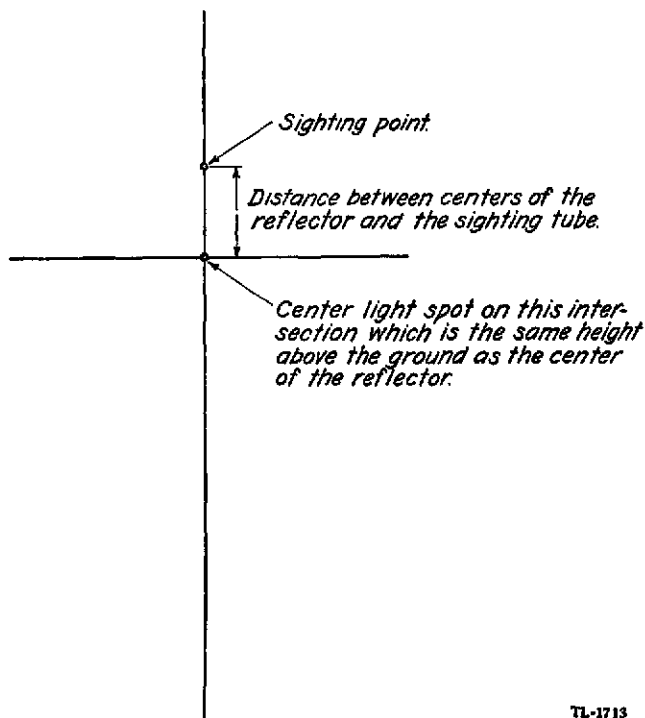

FIGURE 7.—Adjustment of signal lamp equipment EE-6.

■ 124. CARE.—The following precautions are necessary in handling and operating lamps:

a. The lid should be closed when the lamp is not in use and opened only during transmission of signals.

b. The reflector should never be touched with the fingers and should be cleaned only with clean gauze or cotton dampened with clean water or alcohol.

c. Cord connections should be kept clean and tight.

d. The lamp should not be used for illuminating purposes.

■ 125. TRAINING.—Lamp operators should be progressively qualified in the following:

a. The International Morse Code. (See par. 127.)

b. The lamp procedure and the sighting and adjustment of the lamp.

c. The use of field glasses and compass, and in map reading.

d. Inside and outside transmission and reception of signals over distances permitting oral communication between stations.

e. Transmission and reception of messages between stations located beyond speaking distance.

f. The establishment, operation, and maintenance of visual stations under assumed tactical situations.

g. The Fire-Control Code.

■ 126. INSTALLATION.—a. *Location.*—Under favorable conditions the EE-6 will operate satisfactorily up to a range of 3,300 yards in daylight or 6,000 yards at night. (See b below.) The ranges of other types are somewhat greater. Ordinarily the white bulb is used, but the red one is better when operating through smoke or fog. Shadows, reflections, and location affect the visibility of the beam. In daylight it is best to place the lamp in a deep shadow where varying light conditions have the least effect on the visibility of the beam. Sunlight falling on the face of the lamp may produce a continuous glare from the reflector, making signals unreadable to the receiving operator. It is essential that the lamp is accurately sighted on the receiving station, particularly if communication is to be carried on over medium to long ranges. A slight movement of the lamp

throws the beam off the receiving station and the signal becomes either very faint or entirely invisible. It is therefore impracticable to hold the lamp in the hand during transmission, and some form of fixed mounting must be used.

b. Improvisations.—(1) Stability may be attained by fixing the lamp to a tripod of the type issued for use with the prismatic compass or used with commercial cameras. A stake driven in the ground to which the lamp is fastened may be used. Convenience in operating may be improved by providing a battery box to hold the batteries and the spare lamp bulbs, and mounting an ordinary telegraph key on a removable cover. When many lamps are being used in the same general area, it may be desirable to use colored bulbs at night.

(2) In permanent and semipermanent stations lamps may be oriented and fixed in position for communication with the receiving station. Diffusion of the beam and the possibility of signals being read by the enemy may be minimized by providing a wooden tube 6 to 9 feet long, approximately the size of the lamp at the inner end and tapered slightly to a smaller size at the outer end, permanently alined on the receiving station.

■ 127. INTERNATIONAL MORSE CODE.—*a. Alphabet and numerals.*

A	..—	M	— —	Y	— . — —
B	— . . .	N	— .	Z	— — . .
C	—	O	— — — —	1	. — — — —
D	— . .	P	. — — . .	2	. . — — —
E	.	Q	— — . . —	3	. . . — —
F	R	. — . .	4 —
G	— — .	S	5
H	T	—	6	—
I	. .	U	. . —	7	— — . . .
J	. — — —	V	. . . —	8	— — — . .
K	— . . —	W	. — — —	9	— — — — .
L	. — . . .	X	—	0	— — — — —

b. Procedure signals and punctuation.

— . . . —	Break	— — . . . — —	Exclamation
. — . . .	Wait	—	Bar indicating a fraction
. — . . .	End of mes- sage		(oblique stroke)
. . . — . . .	End of trans- mission	. —	Comma
— . . .	Go ahead	— — — . . .	Colon
. — .	Received (OK)	—	Semicolon
.	Period	. —	Quotes
. . — — . .	Interrogation	— — — . . .	Parentheses

■ 128. MESSAGE TRANSMISSION.—*a.* The speed of sending dots and dashes should be constant. Speed of transmission is increased by decreasing the intervals between successive dots, dashes, letters, and words.

(1) A dot is a short flash of about $\frac{1}{2}$ second.

(2) A dash is a long flash about $1\frac{1}{2}$ seconds.

(3) The maximum interval between successive dots and dashes should be about $\frac{1}{2}$ second.

(4) The maximum interval between successive letters or characters should be about $1\frac{1}{2}$ seconds.

(5) The maximum interval between successive words should be about 3 seconds unless the receiving station is acknowledging by one or two dots after each word, in which case, the transmission is resumed immediately upon receipt of each acknowledgment. (See par. 129*b* and *c*.)

b. In order that lamp signals may be easily read it is essential that they be sent slowly. Experienced operators should be able to transmit and receive at the rate of five words of five characters each per minute. Two men for each shift are required to operate a lamp station. In transmitting, one man operates the lamp and watches the receiving station while the other dictates the message to be sent letter by letter. In receiving, one man receives the message and calls it off letter by letter to the other who records it. The receiving operator also acknowledges when acknowledgment is necessary.

c. To establish communication the call sign of the called station is sent several times, and at intervals the station calling sends its own call sign. If two-way visual communication is authorized under the existing conditions, the called station answers in a similar manner by lamp immediately. In case two-way communication is not authorized, the called station answers by pyrotechnic signals or some means other than by flag or lamp.

d. A message consists of the following:

(1) The call, which consists of the call sign of the called station, the letter V, meaning "from", and the call sign of the calling station, except as permitted in paragraph 129b (3).

(2) The body of the message, without address, followed by the ending sign, AR.

■ 129. PROCEDURE (See Fire-Control Code).—a. With obvious modifications, radio procedure is used in the operation of lamps. Addresses are omitted, the contents of the message indicating for whom it is intended. Call signs are prescribed in signal operation instructions and will normally be the same as the radio call signs of the units. (See example facing page 284.) In case of small units having no radio equipment, visual call signs are assigned by the next higher unit commander. These will be used only when required to establish communication or to attract the attention of the called station. Groups provided in the Fire-Control Code (move up, move right, and the like) are used in establishing or improving communication.

b. The following special signals and meanings are used in lamp operation:

(1) One dot: Last word received.

(2) Two dots: Repeat last word.

(3) A series of about ten dots (from transmitting station): Error; (from receiving station): I must interrupt. The series of dots may also be used by the calling station in place of a call to attract the attention of the called station after communication has been established.

(4) CH: Resight your lamp, signals are dim.

(5) A series of dashes of increasing length: Your adjustment is improving.

(6) A very long dash or steady light: Your adjustment is satisfactory.

(7) A series of dashes of decreasing length: Your adjusting is becoming worse.

(8) R: Entire message received.

c. Acknowledgment.—Every message which has been received will be acknowledged by some means even though this acknowledgment is often difficult. In general, lamps will be used only from front to rear, and the acknowledgment in such cases will be made from the rear station by pyrotechnics or some means other than lamp or flag because lamps or flags used for this purpose will permit the prompt location and consequent destruction of the rear station by the enemy. This is particularly important since rear stations are normally located at or near command or observation posts, the destruction of which is especially undesirable. Situations will occur, however, particularly within the infantry battalion and in the field artillery during open warfare when two-way lamp signaling is feasible without possibility of observation by the enemy. In such cases acknowledgment may be made by lamp. If the letter F precedes the transmission, the receiving station acknowledges the receipt of the message by some means other than flag or lamp. In cases where the transmission is not preceded by the letter F the receiving station acknowledges each word with either one dot or two dots, depending upon whether the word was understood or not, and after the transmission is completed (by the group \overline{AR}) acknowledges receipt of the entire message by sending the letter R.

SECTION III

FLAGS

■ 130. EQUIPMENT.—*a.* The general use of flags as a means of visual communication has been discontinued but special conditions warrant or require their use. The following flag equipment is issued for use by the arms and services indicated: The flag kit M-113 (semaphore) by the Field Artillery and Chemical Warfare Service; the flag set M-133 by the Infantry (tanks); and the flag set M-26-B by the coast

artillery harbor defenses and by all arms and services operating seagoing vessels. Other flag equipment, including wigwag flags, is in storage available for issue as directed by the War Department.

b. The M-113 is employed for semaphore flag signaling and consists of a canvas carrying case and two flags with staffs. Each flag is 18 inches square divided diagonally into a red and a white portion and is fastened to a wooden staff 24 inches long.

c. The M-133 consists of an orange colored flag 18 inches square and a steel staff 39 inches long. It is utilized to indicate the command tank of a unit and to direct maneuvers therefrom.

d. The M-26-B consist of 40 flags representing letters, numerals, and special signals. Instructions regarding its use are contained in International Code of Signals, U. S. Navy Department, Hydrographic Office. It is used for communication between ships and between ship and shore.

e. If no standard equipment is available, strips of white or colored cloth tied toward the outer end of sticks of wood or bayonets will serve for flags.

■ 131. CARE.—Signal flags should be kept in serviceable condition. Rents and loose tie tapes should be repaired immediately upon discovery. Soiled flags should be thoroughly washed and dried in the sun to restore color contrast. A clean flag can be seen at greater distances, and signals are thus more easily read.

■ 132. TRAINING.—The steps to be followed in training of flagmen are identical to those given in paragraph 125 for the training of lamp operators, with obvious modifications regarding codes and procedures to be learned. The semaphore flagmen use the semaphore code. (See fig. 8.) A proficient semaphore flagman should be able to transmit and receive at the rate of 125 characters per minute at medium ranges.

■ 133. USE.—a. The ranges at which flag signals may be read vary with the location of the stations, the weather, and the proficiency of the flagmen. Under favorable con-

ditions and with the aid of field glasses, the semaphore flags can be read up to 2,500 yards.

b. The background should be the same for all positions of the flags during the transmission of a message, and the color of the flag should contrast as much as possible with the color of the background.

c. When a slight movement of a station to a better background has been requested by another station, a flagman at each station holds a flag vertically above his head. The station requesting the move lowers its flag immediately when the flagman of the moving station arrives at a position having a suitable background.

■ 134. SEMAPHORE FLAG PROCEDURE.—The semaphore code given in figure 8 is self-explanatory. The "end of message" signal (chop-chop) is executed by waving both flags on the left side of the body in short vertical arcs in opposite directions.

■ 135. SEMAPHORE MESSAGE TRANSMISSION.—The call for semaphore flag signaling consists only of the signal for "attention" when communication is limited to but one other station. Otherwise the call and transmission of messages are identical to that given for lamps in paragraph 128. The special signals and meanings used in semaphore flag signaling are shown in figure 8.

SECTION IV

PYROTECHNICS

■ 136. EQUIPMENT.—*a.* The pyrotechnic devices now used by the Army for signal communication are—

(1) The Very pistol, catalog listing: Pistol, Very, MK. III, 10 gage.

(2) The ground signal projector, catalog listing: Projector, Signal, Ground, MI.

(3) The pyrotechnic pistol, catalog listing: Pistol, pyrotechnic, M2.

b. The Very pistol is a single-shot 10-gage pistol with a 9-inch steel barrel and bronze frame. The barrel is hinged to the frame by a pin and breaks open for loading or extracting the cartridge. The Very pistol cartridge is similar

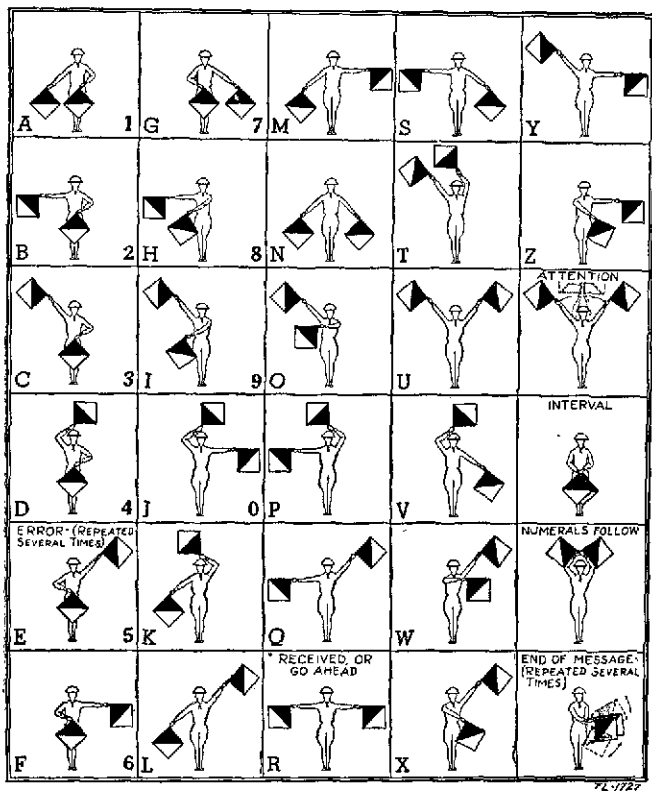

FIGURE 8.—Semaphore code.

in appearance to a 10-gage shotgun shell and contains either a red, white, or green single star signal without parachutes. Upon being fired the signal is projected about 200 feet and burns from 6 to 8 seconds.

c. The ground signal projector consists of a steel tube or barrel about 1 foot long and of 42-mm gage. A firing pin is centered in the bottom or breech and actuated by a simple springless hammer and lanyard. For firing, this is mounted

on the muzzle of the service rifle or on a steel supporting tube about 3 feet long with a flange and sharp pin at one end to be driven into the ground. The signal cartridge resembles a large shotgun shell without a flanged base. It is dropped in the muzzle base first and fired by a quick jerk on the lanyard. After each discharge the projector must be inverted to dislodge the cartridge base. The cartridge contains either a single white star or a red chain signal both with parachutes or a red star cluster signal without parachute which is projected about 300 feet upon being fired.

d. The pyrotechnic pistol is for use in airplanes. It consists of a heavy frame or receiver only, the cartridge serving as the barrel through which the signal is fired. The cartridge is about 1½ inches in diameter and contains either a red or a white single star signal both with parachutes or a parachute flare. The pistol may be held in one hand and fired but due to the severe recoil both hands should be used.

■ 137. CARE.—*a.* Pyrotechnics must not be mixed with ammunition or other fireworks. Those giving red or green light are loaded with compositions which may explode under certain conditions and hence should be stored separately if feasible.

b. All cartridges for the above devices are discharged by percussion; hence boxes of these cartridges should be placed flat with top side up and protected from moisture. Pyrotechnics in storage should be placed by lots of approximately the same date of manufacture and the oldest lots issued first. Those whose serviceability is uncertain will be tested.

■ 138. USE.—*a.* Pyrotechnic devices are used for sending prearranged messages requiring immediate action or when other means of signal communication are uncertain or too slow.

b. The Very pistol, being light and easily carried, is best suited for use by small detachments.

c. In order to insure transmission through fog, dust, and smoke it may be necessary to establish a chain of stations to relay pyrotechnic signals.

d. Some of the principal uses of pyrotechnic signals are to—

- (1) Cause artillery fire to commence, cease, or lift.
- (2) Indicate the arrival of front line units at certain points on the terrain.
- (3) Acknowledge receipt of lamp and flag transmissions by a visual station which is not permitted to use lamps or flags.
- (4) Call for a display of marking or identification panels.

■ 139. TRAINING.—The steps to be followed in the training of pyrotechnic signalmen are—

- a. The care and handling of pyrotechnics.
- b. The firing and reading of pyrotechnic signals.
- c. The employment and tactical use of pyrotechnic signals.
- d. Instruction in map reading and use of the compass.
- e. The establishment, operation, and maintenance of pyrotechnic signaling stations under assumed tactical situations.

■ 140. SIGNALS.—The standard pyrotechnic signals are as follows:

a. *For use from airplanes.*—(1) Signal, aircraft, white star, parachute M10.

(2) Signal, aircraft, red star, parachute M11.

b. *For use from the ground.*—(1) Signal, ground, white star, parachute M5.

(2) Signal, ground, red star, cluster M6.

(3) Signal, ground, red chain, parachute M7.

(4) Cartridge, Very, 10-gage, red.

(5) Cartridge, Very, 10-gage, white.

(6) Cartridge, Very, 10-gage, green.

■ 141. MESSAGE TRANSMISSION.—a. Meanings are assigned pyrotechnic signals in signal operation instructions and should be changed frequently for secrecy. The names given in paragraph 140 are catalog listings and will be used in the signal operation instructions prescribing their meanings. (See page 279 for example.) Since the number of distinct signals is extremely limited and the use of pyrotechnic signals is largely confined to the front lines, the meanings assigned should invariably be those most important to front line units at the time. Pyrotechnic signals, particularly Very signals, are extremely difficult to see in bright sunlight.

They should not be used to control important operations unless no other means are available.

b. Observing the following precautions will avoid misuse of pyrotechnics:

(1) Signals should be distinct from one another.

(2) The most readily discernible signal should be assigned the most important meanings.

(3) Promulgation and distribution of signal operation instructions pertaining to pyrotechnics must be timely.

(4) Each unit commander should designate an officer to be responsible for the use of pyrotechnics by that unit.

(5) Lookouts, and when necessary, relay stations for the repetition of signals should be provided.

SECTION V

PANELS

■ 142. EQUIPMENT.—Several types of panels and panel sets are issued to ground troops. Panels AL-119 and AL-120 issued to the Infantry are 1½-foot squares, the former in white and the latter in black, furnished with grommets and 4 metal pins for staking down the corners. The following arms are issued panel sets AP-30-A and AP-30-B: Infantry, Field Artillery, Coast Artillery Corps, and Signal Corps. The Cavalry is issued the AP-30-B only. The panel set AP-30-A consists of a case CS-18 of canvas for carrying purposes, and 10 panels AL-122 of black cotton fabric, measuring 12 feet in length and 2 feet 4 inches in width, each panel being provided with grommets and 14 metal pins for staking it to the ground. The panel set AP-30-B is similar except the 10 panels AL-121 taking the place of the panels AL-122 are white. Specified coast artillery units are issued panel sets AP-33 and AP-34. Panel set AP-33 consists of 8 panels AL-124 of tangerine colored cotton fabric, measuring 30 feet in length and 6 feet in width with a wooden roller on one end. Panel set AP-34 is similar except the 8 panels AL-125 taking the place of the panels AL-124 are white.

■ 143. CARE.—Panels should be examined each time they are used and any rents or loose grommets promptly repaired. Soiled panels should be washed clean and dried in the sun.

Signals made with clean panels are more easily read than those made with soiled ones. Wet or damp panels should be dried before folding for carrying in order to prevent mildew and to decrease their weight. If a panel set includes a carrying case, the panels should be kept in the case when they are not in use.

■ 144. PURPOSE.—*a.* The AL-119 and AL-120 are marking panels and are displayed by troops in combat on signal from the infantry liaison airplane in order that the airplane may report their progress and location to higher headquarters. The panels AL-120 (black) are used when snow covers the ground, but the panels AL-119 (white) are normally used. These panels are issued on the basis of 3 black and 3 white to a rifle squad and should be used for no other purpose than that for which issued.

b. The AP-30-A, AP-30-B, AP-33, and AP-34 are issued for communication with aircraft and for the location and identification of unit command posts on request by aircraft. The AP-33 and AP-34 are especially designed for communication with high-flying aircraft.

■ 145. DISPLAY GROUNDS.—Panel display grounds are located near the radio station since the panel operators are normally also the radio operators, and communication from the airplane is normally by radio. The panel display ground should be a fairly level open space free from rocks, high weeds, and brush, removed from high trees and bodies of water. It should be defiladed from hostile ground observation but so located that the panels can be seen by airplanes at wide angles from the vertical. The panels should be displayed in the best light available and so placed that shadows will not fall across them blurring their outlines to the air observer. Care must be exercised to see that panels are displayed only to friendly aircraft who have identified themselves as such by use of a prearranged signal or code group. Upon the approach of hostile aircraft the friendly airplane should first be warned and then panels should be taken up and concealed.

■ 146. NUMERALS.—*a.* The three-numeral code groups in the Air-Ground Liaison Code are intended for use with panels. To indicate these numerals the panels are laid out as shown in figure 9.

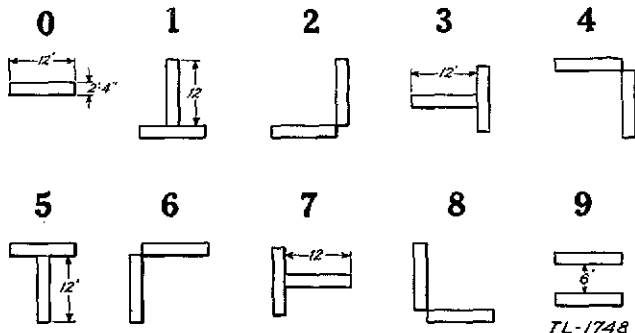

FIGURE 9.—Panel numerals.

b. An index group composed of two panels laid out about 12 feet apart in line is always placed at the top to indicate to the observer the direction in which the panels are to be read. Except as indicated in figure 12, the index group remains in place throughout communication. The three-numeral code group is placed below the index group, as shown in figure 10.

■ 147. IDENTIFICATION GROUP.—Each military unit equipped with panels may identify itself to a friendly questioning airplane or to the airplane assigned to work with it by laying out panel numerals corresponding with a number called an identification group, arbitrarily assigned the unit in signal operation instructions. The identification group may consist of one, two, or three numerals. These identification groups have no relation in any way to the actual numerical designation of the unit. For an example, see page 269.

■ 148. DISPLAYING THE IDENTIFICATION GROUP.—*a.* The panel numerals corresponding to the identification group are dis-

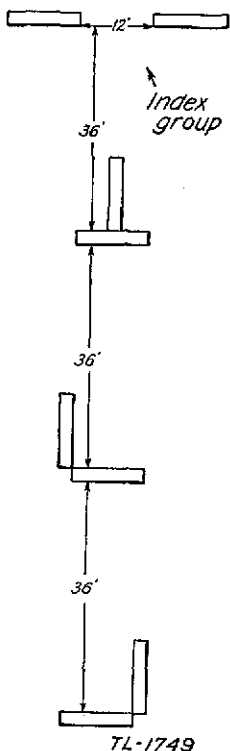

FIGURE 10.—Example of a code group, 182.

played when the airplane sends the code group or gives a prearranged signal meaning "display identification group." In order to indicate that an identification group is being displayed and not a code group, a special signal or indicator for an identification group is laid out simultaneously with the numerals. This consists of a single panel placed about 12 feet above the index group and at right angles to it.

b. If the 13th Field Artillery were assigned 102 as its identification group, this unit would identify itself by displaying panels as shown in figure 11.

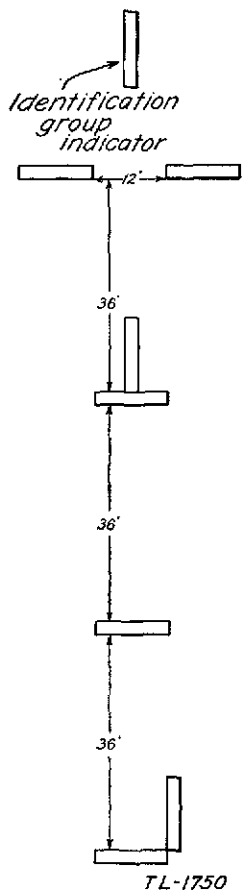

FIGURE 11.—Example of an identification group, 102.

c. When the identification group consists of less than three numerals, it is preceded by one or two zeros, as may be necessary, in order to make a three-numeral group. For example, the identification group 8 would be displayed as the number 008.

■ 149. TECHNIQUE OF PANEL DISPLAY.—*a. General.*—No hard and fast rules governing the space that must be left between the panels composing any signal can be laid down. The distance between all panels should be dictated by local conditions as to visibility at the time of operation, the nature of the terrain, the space and the personnel available, the training of the observer, the type of mission upon which he is engaged, etc. Under average conditions, the display of the numeral panels and the special signals should conform to the form and relative distances indicated in the examples shown in this manual and in the Air-Ground Liaison Code.

b. Preparation.—When two or more operators are available for laying out the panels, the work should be divided up by specific assignment of duties. Special circumstances and good judgment will dictate the best possible division of labor. Constant practice will result in developing a highly efficient panel detail, capable of operating with maximum speed and minimum interference or confusion in movement. Panel operators when preparing to display panels will, according to the number of operators available, post themselves in such positions as will facilitate laying out, changing, and taking up panels with the greatest possible speed and precision. When the display of any signal has been completed, operators move away from the panels rapidly and take up such positions that they will not obscure the signal from observation, or cast shadows upon any part of it. The signal remains displayed until the airplane's acknowledgment has been received, whereupon all panels not in the initial display will always be removed before a new display is made.

c. Beginning.—In order to commence working with the airplane, an initial display consisting merely of the number 000 under the index group is displayed. This means "I am ready to work." This number is not needed in case the

ground station has just identified itself by displaying its identification group. (See par. 150.)

d. Continuation.—In order to avoid misunderstandings, ambiguities, and delays, the noncommissioned officer or the senior operator in charge of the panel detail calls out loudly, in separate numerals, the signal to be displayed, for example, ZERO-ZERO-THREE or THREE-FOUR-FIVE. Much time will be saved if the next signal is announced while the preceding signal is being displayed and the airplane's acknowledgment is being awaited. By so doing, each operator can fix in mind beforehand his exact movements in the next display. In case this procedure is followed, the announcement regarding the signal to be displayed is preceded by the phrase: THE NEXT SIGNAL WILL BE —. The operators then await the command GO before proceeding to execute the order.

■ 150. REPORTING.—*a.* An airplane requests the ground station to identify itself by diving toward the ground station or troops and by throttling the motor twice, or by radio, pyrotechnic, or lamp signals.

b. The ground station answers by displaying its identification group. If not previously arranged for, the ground station will also indicate by panels the joint communication method desired. The communication method may be changed during a mission by displaying the proper panels, or sending the necessary signals. Some methods are described in the following paragraphs.

c. The airplane acknowledges by zooming or by throttling the motor twice unless other signals have been arranged.

■ 151. BETWEEN AIRPLANE RADIO AND GROUND STATION WITH RADIO RECEIVER ONLY.—*a.* The airplane acknowledges receipt of each panel display by sending R, if telegraph, or O-KAY, if voice.

b. If the airplane sends the first message, the ground station acknowledges by displaying the signal 009 meaning "received", followed immediately by the next panel signal.

c. When the last panel signal of a message has been displayed and its receipt has been acknowledged by the air-

plane, the ground station displays the panels meaning "more to follow" or those meaning "end of communication". The latter panels are displayed only when the ground station desires the airplane to proceed on the mission.

d. If the ground station displays the panels meaning "more to follow" only, the airplane acknowledges by sending *R*, but if it displays the panels meaning "end of communication", the airplane acknowledges by sending *R VA* and proceeds on the mission.

e. The airplane reports back from the mission by dropped message, or by other previously arranged means.

f. The ground station acknowledges as in *b* above, followed by the panels meaning "more to follow" if it is desired that the airplane remain in the vicinity, or by the panels meaning "end of communication" if it is desired that the airplane carry on with its reconnaissance, etc.

g. The airplane acknowledges as in *d* above.

■ 152. BETWEEN AIRPLANE AND GROUND RADIO.—See chapter 5.

■ 153. LAMPS, DROPPED MESSAGES, AND PANELS.—*a.* When radio communication is impossible, suspended, or undesirable, the normal method of intercommunication between airplane and ground station is by panels and dropped messages. See chapter 3, section IV. If previously arranged for, the airplane may use the lamp and the ground station may use panels, in which case the procedure used is the same as that indicated in paragraph 129.

b. The normal communication method between airplanes and outlying detachments is by dropped and picked-up messages. (See ch. 3.)

■ 154. INDICATING COMPLETION OF WORK.—*a.* Except for urgent reasons, observers will not leave a mission before the signal meaning "go home" is received, and then only after sending the signal meaning "request relief" three times, the last of which will ordinarily be by means of a dropped message. If no signal meaning "go home" is received, the observer will go home.

b. Only the highest headquarters of the force to which the airplane is assigned will authorize the signal meaning "go home". All subordinate units will habitually send the signal meaning "no further need of you" when they are through with the airplane, upon receipt of which the airplane will report back to the highest headquarters of the force to which it is assigned. Only when specifically directed or authorized to do so by the highest headquarters concerned may a subordinate unit send the signal meaning "go home".

■ 155. SPECIAL PANEL SIGNALS.—Figure 12 shows special signals for use in communicating with aircraft by means of panels. The display in figure 12 ① means "487" and *not* the equivalent of code group 487. If in the display of figure 12 ② panels for 000 were shown instead of those for 895, the meaning would be "verify and repeat coordinates". The display in figure 12 ③ is followed immediately by the display of figure 12 ④.

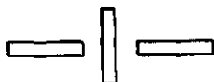

① Hostile plane near you.



② Wind direction.

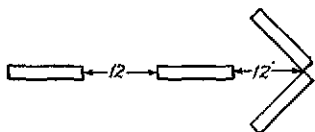

③ In this direction.

TL-1751

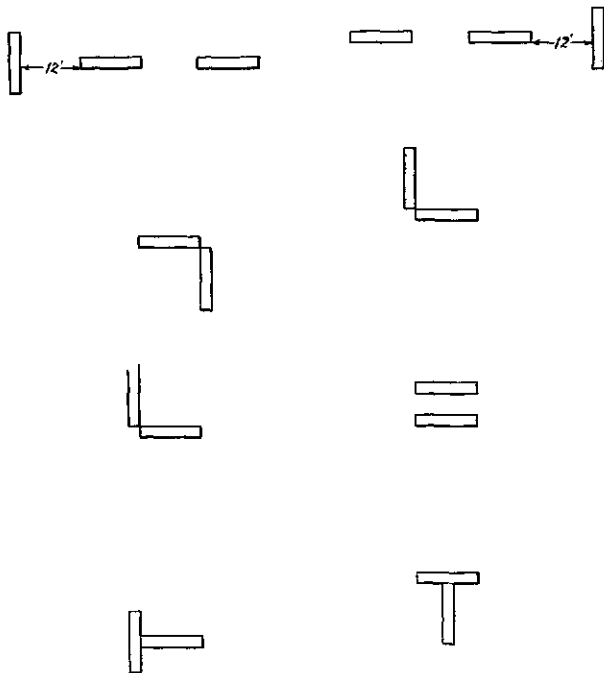

④ Numerals are being displayed, 487.

⑤ Coordinates are being displayed, 895.

TL-1752

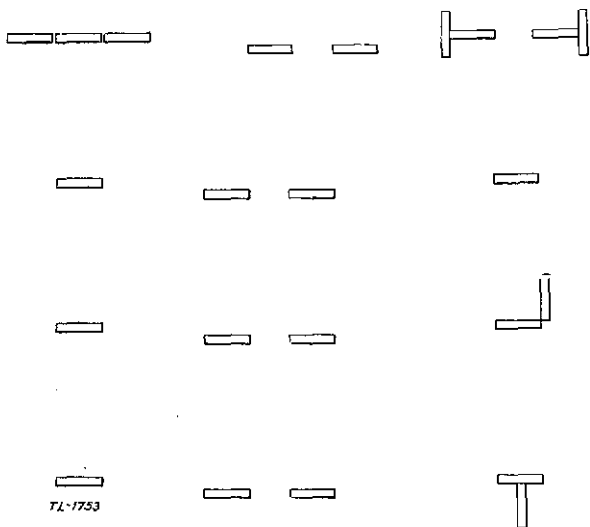

⑥ More to follow.

⑦ Error, cancel last display of panels.

⑧ Reconnoiter 25 miles in the direction to be indicated by next display.

FIGURE 12.—Special panel signals.

SECTION VI

AIRPLANES

■ 156. PURPOSE AND GENERAL USE.—In an emergency, when a ground station is not equipped for radio reception or when the radio transmitter of an airplane is silenced or out of commission, an airplane may communicate to a limited degree with a ground panel station by means of various maneuvers of the airplane while in flight. No standard code has been developed for this means of communication but any code used should be prescribed in signal operation instructions. Individual units have devised such codes by coordination with observation aviation units designated to operate with them. Adjustment of the fire of field artillery batteries using only panel signals and airplane wing signals is both rapid and practicable.

CHAPTER 7

SOUND COMMUNICATION

■ 157. DEFINITION.—Sound communication is the transmission of a message, represented by a prearranged sound produced on an inanimate object, and the direct intelligible reception by ear of that sound. It therefore does not include the transmission of messages either directly by voice or indirectly by messenger, telephone, or telegraph.

■ 158. OBJECTS USED.—Such common sound-producing objects as the whistle, the bugle, small arms, artillery, motors of airplanes in flight, horns, sirens, and rattles are frequently used for signal purposes. The bugle is often used to transmit messages, and the others mentioned above have been used in many operations. Except as indicated in paragraph 159, the use of any object for this purpose may be prescribed by a commander.

■ 159. MESSAGES REPRESENTED BY SOUNDS.—*a.* Messages represented by bugle sounds are prescribed in TR 75-5.

b. Messages represented by whistle sounds are prescribed in other training publications.

c. Sound-producing objects issued for use as gas or air attack alarms will not be used for any other purpose.

d. When messages for the sounds of any object are not prescribed, the commander authorizing the use of the object for this purpose generally will prescribe and publish them in signal operation instructions.

■ 160. EMPLOYMENT.—Sound communication is chiefly of value for alarms, for the purpose of attracting attention, and for the transmission of short prearranged messages and orders. It should be used whenever such use is economical of time, personnel, or equipment and only when the making of the sound will not disclose the presence of troops to the enemy.

CHAPTER 8

WIRE COMMUNICATION

	Paragraph
SECTION I. General	161-183
II. Field wire line construction	184-206
III. Field telephones and centrals	207-225
IV. Field telegraph sets and stations	226-232
V. Maintenance of field wire systems	233-245

SECTION I

GENERAL

■ 161. **DEFINITIONS.**—The following terms used in this chapter are peculiar to wire communication. These terms are defined in the sense in which they are used herein.° For definitions of general terms see paragraph 5, and for definitions of those pertaining to other means of signal communication, see pertinent chapters.

a. Common battery.—Common battery is a term used to describe a telephone system which has current supplied to it from a central source.

b. Field telephone.—A field telephone is a portable telephone designed for field use.

c. Field telephone switchboard.—A field telephone switchboard is a portable telephone switchboard designed for field use.

d. Gaff.—A gaff is a spur on the inside of pole climbers which engages in the pole.

e. Local battery.—Local battery is a term used to describe a telephone system in which current is supplied at each telephone for talking, usually from a dry battery contained in the telephone.

f. Magneto.—A magneto is an electric hand generator used to generate alternating current for signaling telephones or switchboards. Local battery telephones use a magneto for signaling, hence are sometimes referred to as magneto telephones.

g. Marline.—Marline is a small, loosely twisted twine of two strands used for tying field wire to a support.

h. Monocord switchboard.—A monocord switchboard is a field telephone switchboard in which each line terminates in a single jack and plug.

i. Repeating coil.—A repeating coil is a 1:1 ratio transformer used to superimpose additional circuits on field wire lines. (See par. 211.)

j. Seizing wire.—Seizing wire is soft-drawn copper wire, about 22-gage, used to improve field wire splices mechanically and electrically.

k. Skinning.—Skinning is the process of removing insulation from wire.

l. Staggering.—Staggering is the offsetting of splices in the two conductors of twisted pair wire so as to prevent bulkiness and short circuits.

m. Terminals.—Terminals are contacts or binding posts conveniently arranged for connecting equipment or circuits.

n. Test station.—A test station consists of one or more terminal strips cut in on a long trunk or local circuit for test purposes. (See par. 164a.)

o. Wire circuit.—A wire circuit is an electrical circuit consisting of one or more conductors. (See par. 164b.)

p. Wire line.—A wire line consists of one or more wire circuits.

q. Wire pike.—A wire pike is a small pole about 9 feet long used to place field wire lines off or on a road or over limbs of trees, etc.

■ 162. PURPOSE AND SCOPE.—The purpose of this chapter is to standardize the installation, maintenance, and operation of the field wire systems of tactical units. This standardization is necessary to insure efficient wire communication. The individual duties assigned to the wire personnel of units are specifically explained in the training publications pertaining to the different arms. Complete technical information pertaining to particular items of wire communication equipment is found in Technical Regulations.

■ 163. COMPOSITION OF WIRE SYSTEMS.—*a.* The wire system of a tactical unit consists of the telephone and telegraph facilities installed by the personnel assigned to the headquarters of that unit. For example, the division wire system

includes only the wire communication facilities installed and operated by the signal troops assigned to serve the division headquarters.

b. A wire system includes all means of signal communication utilizing wire lines. As regards matériel, it consists of wire circuits and the connecting, operating, and testing equipment for use therewith.

■ 164. CLASSIFICATION OF WIRE CIRCUITS.—*a. According to their use.*—Wire circuits are classified according to their use as follows:

(1) *Trunk* circuits or trunks, which connect telephone or switching centrals.

(2) *Local* circuits or locals, which connect telephones to centrals or to other telephones.

b. According to electrical path.—Wire circuits are also classified according to the path provided for the electric current as follows:

(1) *Ground return* circuits, in which the metallic conductor furnishes only a part of the path for the electric current, the return path being through the ground.

(2) *Metallic* circuits, in which the path for the electric current is completely through the metallic conductors. The metallic circuit has proved to be the more satisfactory for telephone communication. It is less susceptible to interference from other circuits and earth currents, or to interception by hostile listening stations.

c. When superimposed on others.—Additional circuits may be superimposed upon metallic circuits by the use of repeating coils, and when this is done the circuits are classified as follows:

(1) A single metallic telephone circuit may provide an additional telegraph or telephone circuit without mutual interference. This additional circuit ordinarily uses a ground return and is known as a simplex circuit (par. 212). The metallic circuit is said to be *simplex*. A simplex circuit may be used for either an additional ground return telegraph or telephone circuit, but ground return telephone circuits are not desirable. Instead of using a ground return for a simplex telegraph circuit a metallic return path may be

provided by simplexing a second metallic telephone circuit if available. This may sometimes be done when good ground connections are difficult to obtain.

(2) Two metallic telephone circuits may provide an additional telephone circuit without mutual interference. This third circuit is called a *phantom* circuit. (See par. 213.) The two metallic circuits are called *side* circuits or *physical* circuits to distinguish them from the phantom circuit, and the three together are known as a *phantom group*. The phantom circuit of a phantom group may be simplexed for telegraph.

■ 165. RESPONSIBILITY.—*a.* The superior unit is responsible for wire communication from its command post to the command posts of its next subordinate units (par. 10*a*). It is also responsible for lateral wire communication between its adjacent subordinate units. This may sometimes be obtained through a telephone central of the superior unit, or the superior unit may install or direct the installation of the necessary lateral circuits.

b. A supporting unit is responsible for wire communication from its command post to the command post of the supported unit when it is attached as well as supporting.

■ 166. DURING MOVEMENT OF COMMAND POSTS.—The maintenance of wire communication is usually more difficult during the movements of command posts than at any other time. The initial installation of each wire system is planned with the objective in view of maintaining continuous wire communication with subordinate units during and after the movement of command posts. A satisfactory solution in any given situation is normally a combination of the general methods described below. For explanation of symbols used, see paragraph 176.

a. Single-axis method.—In figure 13 assume that the command post of a unit is located at 3 and that the command posts of its subordinate units are at 1 and 6, respectively. The axes of signal communication of these units are 3-5, 1-2, and 6-7, respectively. The superior unit runs one circuit from 3 to 1 via 4 and another circuit from 3 to 6 via 4. Prior to the movement of the command posts of

the subordinate units to 2 and 7, respectively, two circuits are run by the superior unit from 4 to 5, one circuit is continued from 5 to 2, and the other circuit from 5 to 7. When the command post of the subordinate unit at 6 moves to 7, the 3-4-6 circuit is used until the moment the command post closes at 6 and opens at 7. At this instant the 3-4-6 circuit is disconnected at 4, and the 3-4 section of this circuit is connected to the 4-5-7 circuit. The 4-6 circuit may then be recovered or assigned to some other unit. The procedure during the movement of the other command post from 1 to 2 is similar.

b. Multiple-axis method.—(1) In figure 13, assume the same initial locations of command posts and axes of signal communication as before. The superior unit runs two circuits, one from 3 to 1 and the other from 3 to 6. It then lays one circuit along the axis of signal communication of each subordinate unit, passing through 2 and 7, respectively. When the command post of the unit at 6 moves to 7, the 6-7 circuit is connected to the 3-6 circuit. The superior unit maintains the 3-6-7 circuit. The procedure during the move of the command post of the other subordinate unit from 1 to 2 is similar.

(2) As compared with the single-axis method, this multiple-axis method often results in a saving of wire, but the following disadvantages may be noted:

(a) Personnel is dispersed during installation and maintenance.

(b) Resulting system is not so flexible as in the single-axis method.

(c) More personnel is required for installation and maintenance of the system than in the single-axis method.

c. Joint-axis method.—In figure 13, assume that the initial command post of the unit is located at 3, and that the initial command posts of its subordinate units are 1 and 6, respectively. The axes of signal communication of these units are 3-1-2-9, 1-2-9, and 6-7-8, respectively, the axis of the superior unit coinciding with the axis of its left subordinate. The superior unit makes the initial trunk installation by laying circuits 3-1 and 3-6. Should all three units move to position from a common assembly area or

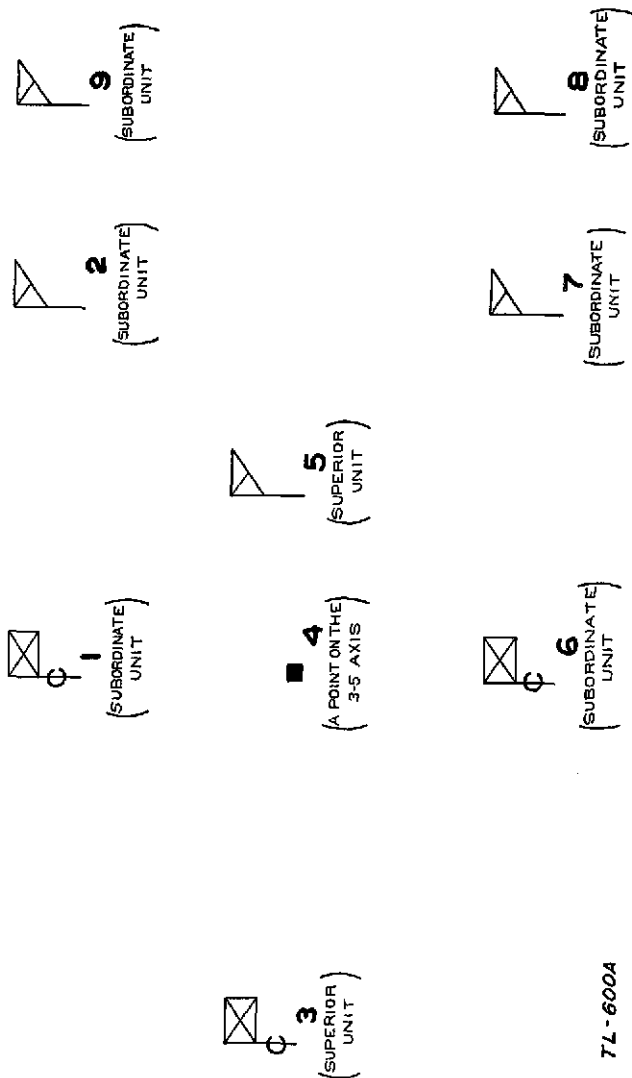

FIGURE 13.—Schematic location of command posts for selection of wire axis.

7L-600A

from the same column in march, these circuits might by agreement be laid by the subordinate units en route to position. Should the left subordinate desire at any time to advance to another command post, as 2, it lays circuit 1-2, and having decided to open at 2, circuit 1-2 is connected to 3-1 at 1, and signal communication is maintained over circuit 3-1-2. The movement from point 1, and the connecting of circuits at that point, are accomplished without interruption of wire traffic. Assume that the subordinate units have advanced, by the foregoing method, to points 9 and 8, respectively. At this time the superior unit decides to advance to 2, located on the axis shared jointly with its left subordinate unit. The superior unit first lays a circuit 2-8 and so installs a switchboard at 2 that traffic may be handled over circuits 3-1-2, 2-8, and 2-9. At a suitable time, the switchboard at 3 is removed and the switchboard at 2 begins to serve the new command post. Should a circuit from 3 to the rear exist, this circuit is connected at 3 to the circuit 3-1, no traffic being interrupted.

d. Teamwork method.—(1) In the methods described above, if the command post of either subordinate unit moves to the new location, prior to the extension of the circuit by the personnel of the superior unit, wire communication will be interrupted. In rapidly moving situations, continuous wire communication between any unit and its subordinate units can be insured only by coordination between those units. The method in (2) below is based upon this coordination.

(2) In figure 13, assume the same initial locations of command posts. Assume also that each unit installs its wire system by the single-axis method, but that the 4-5-2 and 4-5-7 circuits are not completed by the superior unit until after the movement of the command posts of the subordinate units to 2 and 7. Each subordinate unit has laid at least one circuit along its axis, passing through 2 and 7, respectively. When the command post at 6 moves to 7, the 6-7 circuit laid by that unit is connected to the 3-4-6 circuit laid by the superior unit. When the 4-5-7 circuit laid by the superior unit reaches 7, the 3-4-6-7 circuit is disconnected at 4, and the 3-4 section of the circuit is con-

nected to the 4-5-7 circuit. Communication is then maintained by the superior unit over the 3-4-5-7 circuit. The 4-6-7 circuit may be recovered or assigned to another unit. The procedure during the movement of the command post of the other subordinate unit from 1 to 2 is similar. This method makes use of circuits previously laid, but no longer required, by a subordinate unit. It conserves personnel, simplifies construction and maintenance, makes the maximum use of the initial system, and facilitates the continuity of wire communication during the movement of command posts.

■ 167. TELEPHONE; POWERS AND LIMITATIONS.—*a.* The greatest advantage of the telephone is that it affords immediate personal contact between individuals. Disadvantages of the telephone are lack of record of the conversation and the tendency to consume too much time in conversation.

b. The efficiency of the telephone system depends upon a number of factors, the most important of which are—

(1) Type of wire line construction.

(2) Type of equipment used.

(3) Weather.

(4) Training of the personnel operating and using the system.

c. The distance over which satisfactory telephone communication is possible is determined by the electrical characteristics of the telephone circuit. A given type of wire circuit under normal conditions has a definite talking range.

d. The following conditions tend to decrease the efficiency of telephone circuits and the range of telephone communication:

(1) Snow, ice, rain, heavy dew, or fog.

(2) Poor electrical insulation between wires and ground.

(3) Moisture in the telephone instrument, especially in the transmitter.

(4) Weak dry batteries in local battery (magneto) telephones.

(5) Additional telephones bridged across a circuit.

(6) Additional switchboards involved in a connection.

■ 168. TELEGRAPH; POWERS AND LIMITATIONS.—The telegraph is one of the most rapid and accurate electrical means of transmitting messages. In suitable installations, telegraph messages and telephone conversations may be transmitted simultaneously over the same circuit without mutual interference (par. 164c). The ranges of telephone and of telegraph circuits are in general limited by the same factors. Most telegraph instruments have a much greater range than do telephones over a given circuit. A failure to use telegraph channels overburdens the telephone system.

■ 169. TELEPHONE CENTRALS.—a. A telephone central is established at each echelon of a headquarters where two or more local telephones are installed and at junctions of wire lines where switching of circuits is desired.

b. The telephone central serves the following purposes:

(1) It provides flexible intercommunication between local telephones, and affords connection to trunk circuits to other units.

(2) It serves as a switching central at a junction of wire lines, thereby reducing the number of trunk circuits required and adding flexibility to the system.

(3) It furnishes a place at which all circuits are available for test and from which maintenance may be directed.

■ 170. SWITCHING CENTRALS.—A switching central is a telephone central installed at a point other than an echelon of a headquarters for the principal purpose of trunk switching. Switching centrals permit flexibility in the switching of trunk circuits, and their judicious use enables better telephone service to be furnished with the same number of trunks. On the other hand, switching centrals require additional personnel and equipment, necessitate an additional switching operation with increased possibility of interruptions to service, and introduce additional transmission losses. They are used frequently in the wire systems of corps and larger units, and whenever expedient in the systems of smaller units.

■ 171. TEST STATIONS.—Test stations are installed on a wire line to facilitate the testing and rearranging of circuits. They may be located at points where circuits diverge,

at the end of a wire line which does not terminate in a switchboard, near points where circuits are most exposed to damage, at probable future locations of command posts, or at other convenient points on the line. If a command post is established where a test station has been previously installed, the test station can be easily converted into a central. Test stations are usually given a geographical designation, for example, Jones Farm Test. In the situations given in paragraph 166 *a* and *d*, the location of test stations at points 4 and 5 would facilitate the rearrangement of circuits after the movement of the command posts of the subordinate units.

■ 172. ORDERS AND INSTRUCTIONS.—In divisions and higher units, instructions concerning the wire system for a particular operation are usually included in a signal annex or in an appendix thereto. In brigades and lower units the corresponding instructions are usually issued orally. In either case the plan of installation can best be shown by a circuit diagram and a line route map. See instructions, forms, and examples in chapter 10.

■ 173. CIRCUIT DIAGRAM.—*a.* A circuit diagram gives schematically the technical arrangement and connections of the circuits and terminal installations of the wire system. It is a means of giving to wire personnel detailed instructions for the installation of the system and of assisting them in its maintenance. The circuit diagram contains technical information necessary for wire personnel to install wire lines, centrals, test stations, and telephones on long local circuits, and to simplex or phantom the required circuits. (See example, p. 260.)

b. The circuit diagram indicates—

(1) Telephone centrals at command posts and establishments served by the wire system, commercial telephone centrals, switching centrals, test stations, and long local telephone circuits, that is, circuits to local telephones not in the immediate vicinity of a telephone central. These are shown by their special symbols (par. 176) and their telephone directory names. Their locations are indicated by names of map or terrain features and by coordinates.

(2) The number of circuits, including trunks and long locals, between each of the command posts or establishments shown.

(3) The number assigned to each circuit. (See par. 174.)

(4) The manner of connecting each circuit into or through telephone centrals and test stations. This includes the connections for simplex and phantom circuits.

(5) The type of line construction used for each line, such as field wire, open wire, cable, commercial circuits, etc.

■ 174. DESIGNATING LINES AND CIRCUITS.—*a.* Wire lines and circuits are given individual designations by the organization installing them. These designations are used in orders and reports.

b. In large wire systems, as those of corps or armies, each important wire line is designated by a name or number, for example, cable No. 2 or GETTYSBURG-CHAMBERSBURG line. In such systems, each wire circuit is given a number, for example, circuit No. 612. The designation of wire circuits in such a system consists of the number of the circuit followed by the name or number of the line, for example, circuit No. 50, cable No. 6, or circuit No. 561, NEW YORK-WASHINGTON line.

c. In smaller wire systems, circuits are not normally designated by name. A wire circuit in such a system is designated by its individual number, followed by the title of the organization constructing the circuit, for example, No. 101-1st Div. In units smaller than a division, the numbering of circuits may also be omitted whenever the omission will not render prompt identification, test, and maintenance more difficult. However, in such cases, the name of the unit to which the circuit belongs will be written on one side of the wire tag and the unit or activity it serves on the other; for example, 1st FA on one side and 1st Bn, 1st FA, on the other side. The complete circuit designation is used in circuit diagrams, orders, or reports whenever necessary to avoid confusion.

d. In assigning numbers to wire circuits the following general rules are observed:

(1) No two circuits in a named or numbered wire line are given the same number.

(2) No two circuits constructed by the same organization during a single operation are given the same number.

(3) All wire lines are divided into sections. A section begins and terminates at successive centrals, test stations, or (in the case of a long local) at a telephone. A circuit passing from one section to another is given a different designation on entering the new section.

e. In the wire systems of divisions and lower units, construction and maintenance are facilitated by a numbering system which identifies the general position of each circuit with respect to other circuits in the same system. The example on page 260 illustrates one system of numbering which is given only as a guide. However, any system of numbering that will meet the requirements of the situation and, in general, conform to the provisions of this paragraph may be used. The system of numbering illustrated provides for the allotment of a block of numbers to each section of the line along the axis and to each section of the line laterally from the axis both to the right and left. Beginning at the rear echelon of the division, each section of the line along the axis is allotted a block of 10 numbers of three digits each—hundreds, tens, and unit. The hundreds begin at 1 and increase in arithmetical progression for each section of the line. The last two digits are from 01 to 10 in each section of the line. Laterally to the left each section of the line is allotted a block of nine numbers, the hundreds' number being the same as the section of the axial line, terminating at this point of divergence. The last two digits are from 11 to 19. The next section to the left maintains the same hundreds' number and takes the next block of nine numbers beginning with an odd number, that is, 31 to 39, etc. The same method is applied to the allotment of numbers to the sections to the right of the axis, using, however, for the last two digits, blocks of nine beginning with even numbers, that is, from 21 to 29, 41 to 49, etc.

■ 175. LINE ROUTE MAP.—*a.* A line route map is a map, map substitute, or overlay on which are shown the actual routes of wire circuits. It may be used to designate how a wire system will be installed, but its principal use is in

reporting the physical location of wire circuits for the information of wire personnel and the superior unit. If an overlay, at least two orientation points taken from the map must be shown, and a reference must be made on the overlay to the map used. The line route map contains as few lines, symbols, and notations as is consistent with its purpose. It shows the routes but not the actual connections at centrals or test stations. (See example, p. 262.)

b. A line route map contains the following additional information:

(1) Location, by means of proper symbols, of each headquarters or establishment served by the wire system.

(2) Locations, by means of proper symbols, of telephone centrals, switching centrals, test stations, and long locals.





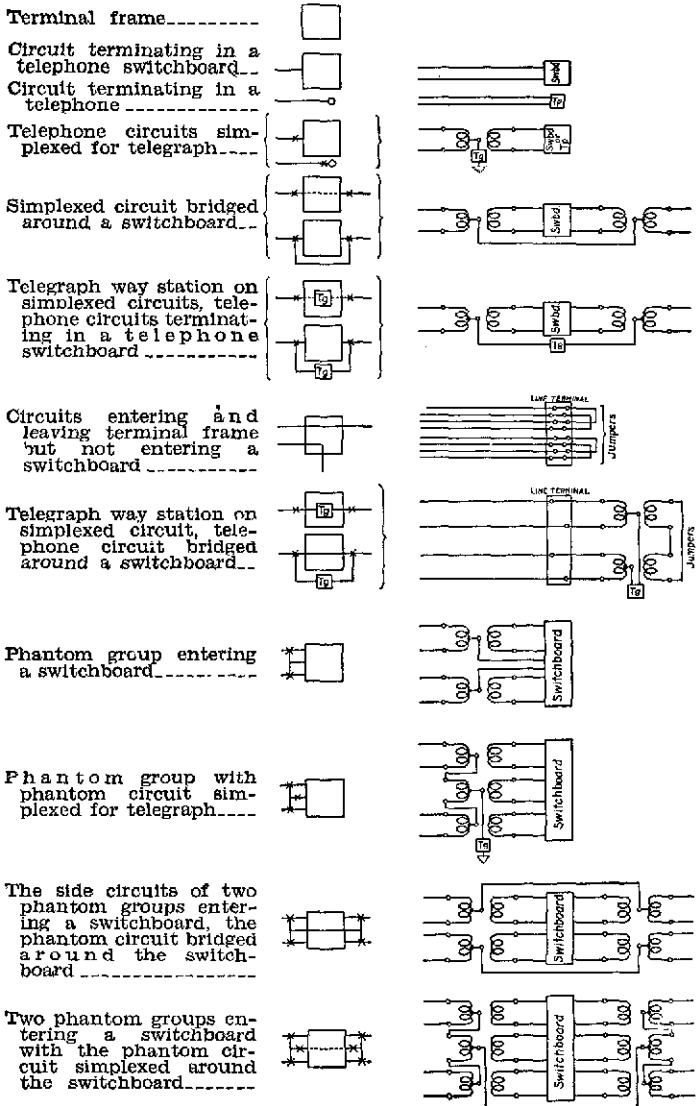

(3) The actual route of each wire line, the type of line construction, and the number of physical circuits in each section of the line.

(4) Explanation of any special symbols used which are not contained in paragraph 176.



■ 176. SPECIAL SYMBOLS.—The following special symbols are authorized for use as indicated in or in addition to those authorized in FM 21-30.

a. *Symbols for circuit diagrams, indicating circuits, connections, and installations.*









Field wire circuit, twisted pair.....	
Commercial circuit of two wires.....	
Several circuit pairs of the same general type.....	
Circuit (No. 101).....	
Circuit when not constructed by unit issuing the diagram.....	
Interrupted or dead-ended circuits.....	





b. Symbols for line route map, indicating wire lines.

Wire line.....	
Number of circuits in a wire line.....	
Standard pole line.....	





c. Basic symbols for circuit diagrams, line route maps, traffic diagrams, and signal operation maps.

Telephone central located at an echelon of a headquarters.....	
Switching central of a tactical unit.....	
Commercial telephone central (add commercial designation on top of symbol).....	
Test station or cable terminal.....	
Probable future location of a cavalry command post, indicating a point on the axis of signal communication.....	
Probable future location of an infantry command post, indicating a point on the axis of signal communication.....	
Probable future location of a field artillery command post, indicating a point on the axis of signal communication.....	

d. Symbols for telephone traffic diagrams.

Telephone channel.....	
Number of telephone channels.....	
Telephone central or switching central.....	
Telephone.....	

e. Application of symbols.

Telephone central at command post, First Army -----	
Telephone central at command post, II Corps -----	
Commercial telephone central -----	
Commercial central controlled or operated by army signal troops -----	

7L-1351A1

■ 177. TELEPHONE DIRECTORY.—*a.* To simplify and expedite the operation of field telephone systems, a telephone directory is used. This directory consists of two parts which are issued together as one item of signal operation instructions. (See example, p. 280.)

b. Telephone directory names are assigned to organization headquarters, and telephone directory numbers are assigned to the various officers and offices of a headquarters. Telephone directory names of organizations within a division all begin with the same initial letter.

c. Directory names when once assigned remain fixed and are not changed except when necessary to avoid conflict with directory names of other units. Directory numbers assigned remain fixed and are uniform throughout all units.

d. Directory names and numbers are not intended for secrecy, but are prescribed for purposes of simplicity, accuracy, and speed in the handling of telephone calls. To secure its purpose, the telephone directory must be habitually used by all telephone switchboard operators and telephone users. However, operators should be instructed to put through calls regardless of how they may be placed. A copy of the telephone directory is attached to each field switchboard and telephone in use.

■ 178. TELEPHONE CONVERSATIONS.—*a.* In placing a telephone call the complete designation of the party desired is given to the switchboard operator, including the directory name of the unit and the directory number of the party. However, when placing a call to a party at the same headquarters or echelon served by the same switch-

board, it is not necessary to give the directory name of the unit.

b. In answering a telephone call, the expression "hello" should not be used. The individual answering the call states the directory name and number of that telephone and identifies himself, as "Magic three, S-3 (or Captain Jones) speaking."

c. Telephone conversations should be brief, as long conversations deprive others of the use of the circuits. This can best be accomplished by mentally preparing the subject matter of telephone conversations before the call is made. The telephone should not be used for long reports, orders, or messages when messenger or telegraph communication would serve as well or better. Telephone conversations must be discreet since secrecy is never assured. Telephone conversations may be intercepted by direct tapping of the line, by induction from our own lines, and by leaks to the ground and thence to enemy listening sets.

d. No unnecessary conversations should be held with the switchboard operator, and he should be spoken to in a civil manner. In case it is desired to make a complaint regarding the service, it should be made to the chief operator or the signal or communication officer. The operator should not be directed how to route a call, nor should the calling party attempt to route his own call by merely asking for connection to a certain central. The operator is best prepared to put through a call in the fastest time when he is given the complete designation of the party to be called.

■ 179. URGENT CALLS.—a. Because of the limited number of wire circuits between telephone centrals, they will often be found busy when they are needed for very important traffic relating to immediate operations. It may also occur that even when the trunk wire circuits are available the local circuit to the called party is in use. In order to avoid delaying an important critical call, personnel are authorized to class a telephone call as *urgent* when they believe it is

more important than any call which may be in progress. In placing an urgent call the calling party adds "Urgent call" after the designation of the called party, as: "Magic six, urgent call". The urgent classification should be used cautiously. Signal and communication officers should supervise the telephone system to insure the privilege is not abused.

b. An urgent call is completed by a switchboard operator with all possible haste at the expense of any routine call which may be in progress. The procedure of the operator is explained in paragraph 217.

■ 180. CONFERENCE CALLS.—a. At certain times it is desirable for a commander or one of his staff officers to obtain telephone connection with two or more other individuals at the same time in order to transmit instructions or information to all parties simultaneously. For this purpose the conference call is used.

b. A conference call is obtained by the calling party stating to the operator "Conference call", giving the telephone directory designations of the parties desired, such as "Dragoon six, Domino six, Diamond six", and giving his own directory designation if necessary. The calling party may instruct the operator that in the absence of any particular called party certain other staff officers or their assistants will be satisfactory. After placing a conference call, the calling party may hang up to wait recall by the operator. The connection is established by the operator as described in paragraph 216.

■ 181. PHONETIC ALPHABET.—a. The phonetic alphabet and the pronunciation of numerals (par. 182) are extracted from the Joint Army and Navy Radiotelegraph and Radiotelephone Procedure which is in effect at this time. They are prescribed for wire communication as well as for radio communication.

b. Certain letters of the alphabet have similar sounds and are often confused in telephone conversations. To avoid this

difficulty, the following pronunciation of letters over the telephone is prescribed:

Letter	Spoken as	Letter	Spoken as	Letter	Spoken as
A	Afirm	J	Jig	S	Sail
B	Baker	K	King	T	Tare
C	Cast	L	Love	U	Unit
D	Dog	M	Mike	V	Victor
E	Easy	N	Negat	W	William
F	Fox	O	Option	X	Xray
G	George	P	Prep	Y	Yoke
H	Hypo	Q	Queen	Z	Zed
I	Inter	R	Roger		

c. The words of the phonetic alphabet are used in place of the letters they represent just as in spelling a word. Expressions such as "A as in Afirm" or "A for Afirm" are not used. For example, in transmitting the words BARTS CHURCH the word BARTS is apt to be misunderstood. The phonetic spelling is as follows: "BARTS, Baker-Afirm-Roger-Tare-Sail."

d. The phonetic alphabet is also used in the transmission by telephone of coded messages. For example, the code group XISV is transmitted as "Xray-Inter-Sail-Victor."

■ 182. PRONUNCIATION OF NUMERALS.—a. The following pronunciation of numerals is prescribed in telephone transmission:

Numeral	Spoken as	Numeral	Spoken as
0	Ze-ro	5	Fi-iv
1	Wun	6	Siks
2	Too	7	Sev-ven
3	Th-r-ee	8	Ate
4	Fo-wer	9	Ni-yen

b. Numbers are transmitted as numerals or digits except in the case of an even hundred or thousand, when the word hundred or thousand is used. Examples:

Number	Spoken as	Number	Spoken as
44	Fo-wer fo-wer	500	Fi-iv hun-dred
80	Ate ze-ro	1478	Wun fo-wer sev-ven ate
136	Wun th-r-ee siks	16000	Wun siks thou-sand

c. When giving a telephone number to a switchboard operator, speak the directory name deliberately and distinctly, pausing between the name and the first numeral. Speak each numeral separately, pausing slightly between numerals. Examples:

Directory name and number	Spoken as
Table 44.....	Ta-ble, fo-wer fo-wer
Turkey 80.....	Tur-key, ate ze-ro
Track 6100.....	Track, siks, wun, hun-dred

■ 183. REPORTS AND RECORDS.—a. In order to make the most efficient use of the wire system, the signal or communication officer keeps himself informed of the condition of the systems of his own and subordinate units. Subordinate units report to next superior units when the wire system is first installed and thereafter whenever important changes are made. These reports are usually made by telephone or telegraph, supplemented by line route maps and circuit diagrams.

b. The signal or communication officer requires the signal or communication troops under his immediate supervision to keep such records relating to the wire system as are essential to its efficiency. These records cover installation, maintenance, and operation. They are seldom kept in small units where few circuits are maintained. Reports are made by the chief of construction on the installation or recovery of wire lines. When necessary, the operating personnel keep station logs, and test and trouble reports. (See secs. III and V.)

SECTION II

FIELD WIRE LINE CONSTRUCTION

■ 184. GENERAL.—Field wire lines are constructed of insulated field wire or commercial substitutes. They are used within the zone subject to hostile shell fire and in rear areas when time does not permit of other types of construction. The wire systems of the infantry division and its units normally consist of field wire lines.

■ 185. TYPES OF FIELD WIRE.—Two types of field wire are issued. Both conductors of both types are insulated with rubber compound and weatherproof braid. Their characteristics and approximate transmission distances are shown in the table below:

Characteristics	Wire 110	Wire 110-B
Number of conductors.....	2 twisted.....	2 twisted.
Tensile strength.....	340 pounds.....	246 pounds.
Satisfactory transmission distance:		
Unloaded.....	10-15 wire miles.....	11-17 wire miles.
Loaded.....	14-22 wire miles.....	16-24 wire miles.
Issued:		
On reel DR-4.....	2,400 feet.....	2,400 feet.
On reel DR-5.....	1 mile.....	1 mile.
In coils.....	1,000 feet.....	1,000 feet.
Weight:		
Wire alone.....	132 pounds per mile.....	132 pounds per mile.
Reel DR-4 filled.....	82 pounds.....	82 pounds.
Reel DR-5 filled.....	166 pounds.....	166 pounds.
Conductor:		
Composition.....	5 steel and 2 copper strands.....	4 steel and 3 copper strands.
Tensile strength.....	200 pounds.....	145 pounds.
Resistance.....	130 ohms per mile.....	95 ohms per mile.

■ 186. WIRE SPLICES.—The kind of splice depends upon the types of wire to be connected. The installation may require the splicing of field wire to field wire, of field wire to solid conductor wire, either bare or insulated, or of one solid conductor to another. In making splices there are three cardinal principles to be observed. If they are observed the resulting splice will have all the inherent qualities of the wire itself. These principles are the—

Conductivity of the wire must not be impaired;
 Insulation resistance must not be decreased; and
 Tensile strength of the wire must not be materially decreased.

a. Field wire splice.—The standard field wire splice, utilizing copper seizing wire, is used to splice all types of stranded conductor field wire. Every soldier engaged in communication work should be able to make a proper wire splice. Occasions constantly arise in which such ability is

necessary. It is therefore important that the entire unit be trained for this work (par. 238*d*).

(1) *Teamwork in splicing*.—When making splices it often happens that there is more than one man available at the time the splice is being made. In that case, the over-all time for the splice can be greatly reduced if the two men have a standard cooperative method and function as a team. Only the teamwork splice is described since the same procedure can be followed by one man working alone.

(2) *Staggering splice* (fig. 14).—Each man prepares one of the two wires which are to be spliced together. To obtain a uniform stagger, each man measures back one plier's length (about 6 inches) from the end of one conductor of the wire he is preparing, and cuts off the conductor thus measured. Each man now has two conductors, with one cut so as to be one plier's length shorter than the other.

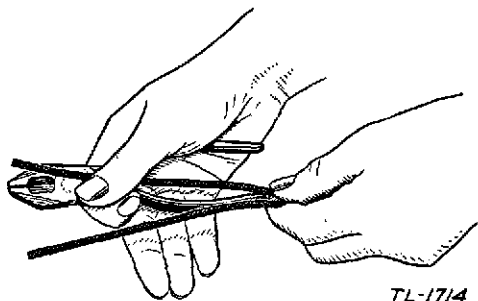

FIGURE 14.—Staggering splice.

(3) *Crushing insulation*.—Each man now begins crushing the insulation on his long conductor at the point where the short one ends, that is, one plier's length from the end of the long conductor. (See fig. 15.) Using the heel of his pliers, he crushes the insulation toward the end for a distance of about 4 inches, leaving about 2 inches of the insulation uncrushed on the end of the conductor. He next measures back one plier's length along the short conductor, and in a similar manner crushes about 4 inches of its insulation. (See fig. 16.) The uncrushed insulation re-

maintaining on the ends of the conductors holds the strands of the conductor together, prevents possible injury by the steel strands to the splicer, and greatly reduces the over-all splicing time. The two operations described above give a uniform stagger to insure equal tension on both conductors of the wire when the splice is completed.

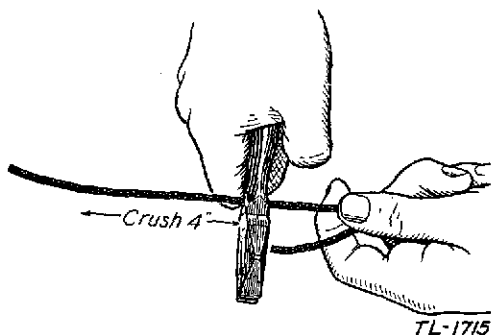

FIGURE 15.—Crushing insulation on long conductor.

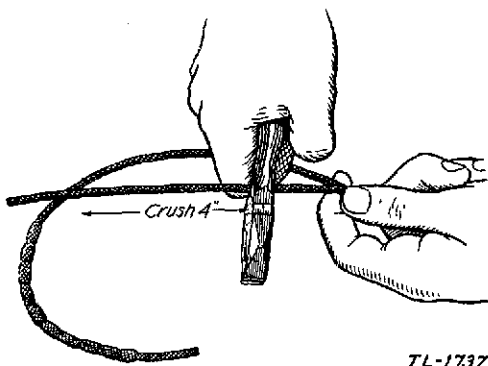

FIGURE 16.—Crushing insulation on short conductor.

(4) *Skimming conductor.*—Each man scores or rings the crushed insulation of both conductors with the cutting edges of his pliers at a point about $\frac{1}{2}$ inch from the point at which the crushing began. Then, changing the hand grip on his

pliers as shown in figure 17, he draws the cutting edges of his pliers straight along the conductor so as to push the crushed insulation ahead of the pliers. In this operation, care is taken to draw the pliers perpendicularly along the conductor, as drawing the pliers at any appreciably different angle to the conductor will nick or break the strands thereof. He then bares about $3\frac{1}{2}$ inches of the strands of the conductor. Although slower, this skinning may be done satisfactorily with less danger to the strands by using the gripping jaws or the heel of the pliers instead of the cutting edges. If these strands appear dirty, he carefully scrapes them with the back of the screw driver blade of his electrician's knife. The entire procedure of staggering the splice, crushing the insulation, and skinning the wire should not take over 1 minute.

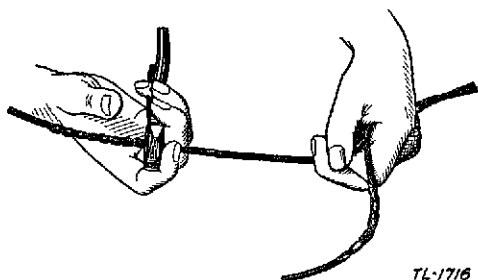

FIGURE 17.—Skinning conductor.

(5) *Tying square knot.*—The ends of the two wires are now brought together and the long conductor of one wire and the short conductor of the other are tied in a square knot by each man (fig. 18). The square knot is so placed as to leave a distance of about $\frac{1}{4}$ inch between the knot and the rubber insulation. The weatherproof braid of the conductor is then peeled back from the $\frac{1}{2}$ inch of wire that was crushed but not skinned. This leaves $\frac{1}{2}$ inch of exposed rubber insulation to permit close adhesion of the rubber tape when it is applied. (See figs. 19 and 20.)

(6) *Applying seizing wire.*—A 6- to 8-inch piece of seizing wire is inserted up through the square knot and then the

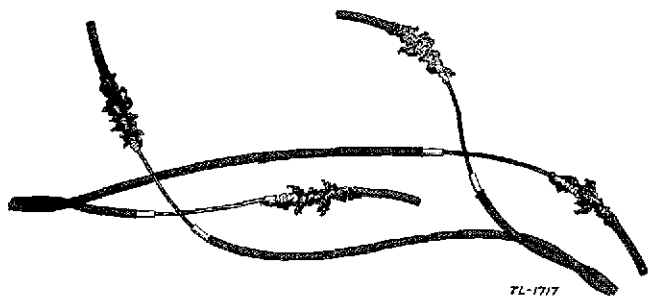

FIGURE 18.—Wires skinned and ready for square knots.

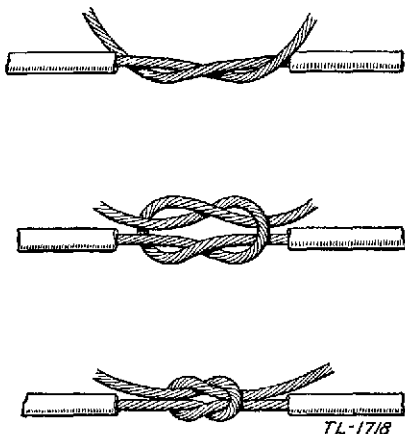

FIGURE 19.—Tying square knot.

knot is pulled tight (fig. 20). The seizing wire is bent so as to have half for wrapping to the left and half for wrapping to the right. Two or three close turns are taken with the seizing wire, both to the left and to the right of the square knot (fig. 21). This is to bind the ends of the knot before cutting off the excess ends of the conductors. Now the excess ends of the conductors are cut off flush with the rubber insulation. The seizing wire wrap is then continued both left and right of the square knot until two

turns are taken on the rubber insulation (fig. 22). The ends of the seizing wire are now cut off flush and pressed down into the rubber. With both men tying the square knots and applying the seizing wire at the same time, the over-all time for these operations should be about 1 minute (fig. 23).

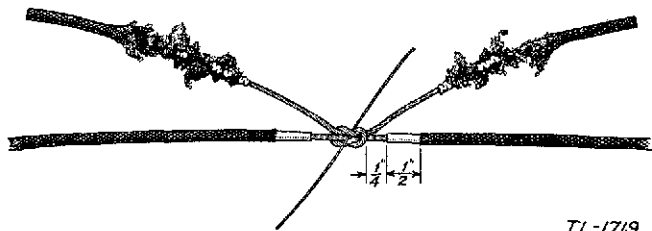

FIGURE 20.—Seizing wire inserted through knot.

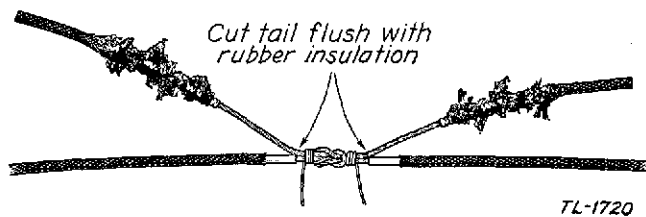

FIGURE 21.—Wrapping seizing wire.

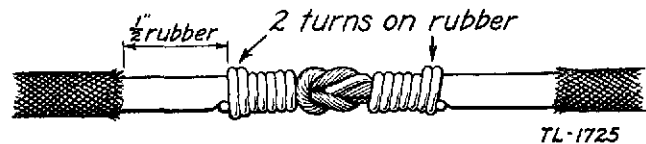

FIGURE 22.—Splice on one conductor after seizing is completed.

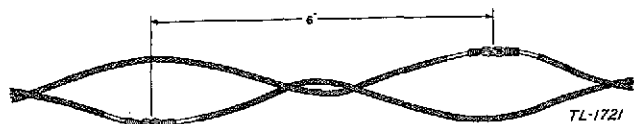
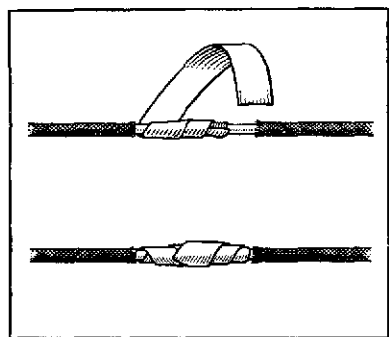

FIGURE 23.—Splice ready for taping.

(7) *Applying rubber tape.*—For best results and ease of application, the wire is held taut when the rubber tape is being applied. One man holds the wire taut and the other applies a 4- to 5-inch piece of rubber tape to the splice in two layers. It is started at the center of the splice and is worked to the left and right of the knot for a distance of $\frac{1}{2}$ inch on the rubber insulation. (See fig. 24.) The rubber tape is stretched considerably so as to give close adhesion, and is pressed into intimate contact with the rubber insulation on both ends of the splice to keep the splice waterproof.

(8) *Applying friction tape.*—With one man holding the wire taut, the other man applies two layers of friction tape



7L-1722

FIGURE 24.—Applying rubber tape.

over the rubber tape. The friction tape is extended about 1 inch beyond the rubber tape. (See fig. 25.) This gives an over-all taped splice of about 4 inches. The finished splice is then rolled several times in the hands to seal the edges of the tape.

b. *Western Union splice* (fig. 26).—The Western Union splice is used in splicing two solid conductor insulated wires. To make the splice, strip the insulation from the end of each wire for a distance of about 8 inches and clean the wires so that they are bright and free from corrosion. Twist the bare ends together in the center for about $2\frac{1}{2}$ inches. Then

bend the ends at right angles to the axis of the wire and wrap each end around the wire with at least five close turns. The twisted portion of the splice is called the "neck", and

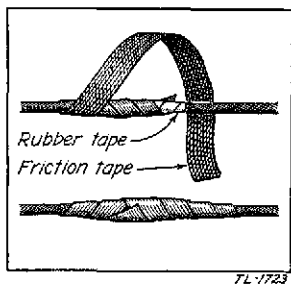

FIGURE 25.—Applying friction tape.

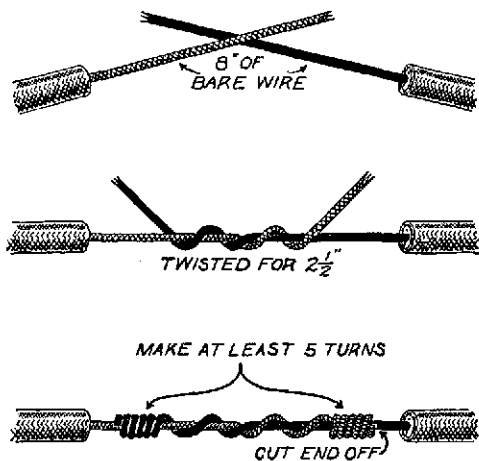

FIGURE 26.—Western Union splice.

the five turns at each end are called the "buttons". Cut off the ends as closely as possible, being careful not to leave a sharp point that will puncture the tape wrapping. See paragraph 187 for taping this splice and those which follow.

c. Combination splice (fig. 27).—The combination splice is used to splice a stranded conductor insulated wire to a solid conductor insulated wire. To make the splice, strip the insulation from the end of each wire for a distance of about 6 inches and clean the wires so that they are bright and free from corrosion. Tie an overhand knot in the stranded wire close to the insulation and slip it over the solid wire to within $\frac{1}{2}$ inch of the insulation. Pull the knot tight and wrap the end of the stranded wire around the solid wire from the knot to the insulation. Cut off the surplus stranded wire. Bend the end of the solid wire back at the knot and with it seize the stranded wire, wrapping it up as far as the insulation. Wrap the solid wire in the direction opposite to the wrappings of the stranded wire, otherwise the solid wire will fail to hold the strands in place. Continue the wrapping of the solid wire until two turns are taken over the insulation. Cut off the surplus solid wire and press the end down into the insulation.

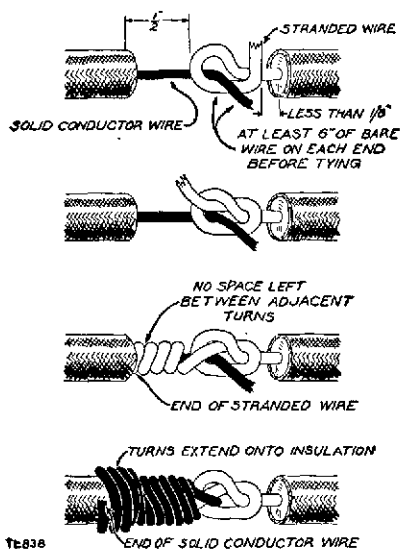

FIGURE 27.—Combination splice.

d. Combination seizing wire splice (fig. 28).—This splice is used to splice a stranded conductor insulated wire to a solid conductor bare wire such as is used in an open wire pole line. Strip about 1 inch of insulation from the end of the stranded wire and clean both wires so that they are bright and free from corrosion. Lay this end of the stranded wire along the solid wire. Begin the seizing by taking four turns with the seizing wire around only the solid wire back of the stranded wire. Continue the wrapping, including several turns over the insulation of the stranded wire, then over the bare end of the stranded wire, and finish with four turns over the solid wire only. Wrap the seizing wire tightly and draw the turns close against each other. (See fig. 34 for tying-in the splice.)

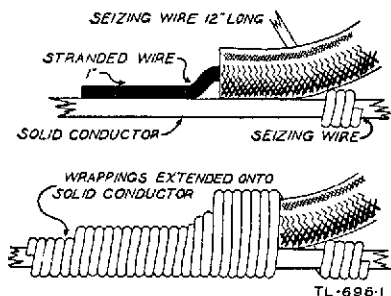

FIGURE 28.—Combination seizing wire splice.

e. Commercial splice (fig. 29).—The commercial splice is used to splice a solid conductor insulated wire to a solid conductor bare wire such as is used on an open wire line. To make the splice, remove the insulation from the insulated wire for a distance of about 6 inches and clean both wires so that they are bright and free from corrosion. Lay this bare end of the insulated wire along the bare wire. Bend this end at right angles to the bare wire and wrap it around the bare wire for at least eight turns, drawing the turns tight and close together. Cut off the surplus end of the insulated wire.

f. T-splice.—The T-splice is used to splice a wire to another without interrupting the circuit of which the latter is

SIGNAL COMMUNICATION

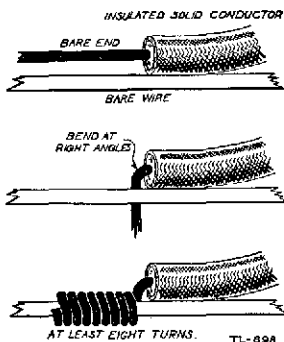

FIGURE 29.—Commercial splice.

a part. In figure 30, **X** is the latter and **Y** is the former. In this illustration it is assumed that after the splice is completed the portion of **X** to the left of the splice will be discarded and that the strain will be toward the right. To make the splice—

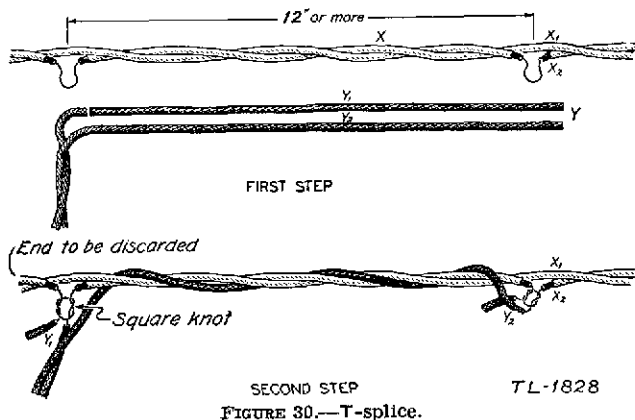

FIGURE 30.—T-splice.

(1) Remove about $1\frac{1}{2}$ inches of insulation from each of the conductors of **X**, 12 or more inches apart.

(2) Place **Y** beside **X** with the two ends at one of the bared places.

(3) Cut Y_1 off at the other bared place, and prepare the ends of Y_1 and Y_2 for splicing as in *a* (3) and (4) above.

(4) Tie Y_1 to X_1 with a square knot. To tie this knot, make a loop with the left hand in the bared portion of X_1 ; with the right hand, pass the end of Y_1 up through the loop, over the right side of the loop, under the neck of the loop over the left side of the loop, and down through the loop; draw the knot tight. To avoid making a thief knot, be sure that the two conductors on which the strain is to be placed are on the same side of the loop or otherwise the knot will not hold.

(5) Twist Y_2 around X_1 and X_2 , and tie Y_2 to X_2 , similarly.

(6) Cut off the portion of X to be discarded and complete the splice as indicated in *a* (6), (7), and (8) above.

■ 187. TAPING SPLICES.—*a*. See paragraph 186 *a* (7) and (8) for taping the field wire splice. Other splices in insulated wire (par. 186 *b*, *c*, and *f*) are wrapped first with two layers of rubber tape and then with two layers of friction tape. In order that the completed splice will be well insulated it is important that the rubber tape make intimate contact with the rubber insulation on each side of the splice. This is done by removing or pushing back the braid covering the rubber insulation for a short distance on each side of the splice and scraping the rubber so that a clean surface to which the rubber tape will adhere closely is obtained. The rubber tape wrapping begins and ends at the center of the splice and extends over the rubber insulation for a distance of $\frac{1}{2}$ inch. (See fig. 24.) The rubber tape is stretched tightly in wrapping and pressed into close contact with the rubber insulation. Next the splice is wrapped with two layers of friction tape. The friction tape wrapping begins and ends at the center of the splice and extends over the braid of each wire for a distance of one inch. The tape is drawn tightly against the braid, particularly at the ends, to make the splice as waterproof as possible. (See fig. 25.)

b. When insulated wire is spliced to a bare wire the splice is wrapped with two layers of friction tape to assist in holding the wire firmly in place. The insulated wire is brought

out between the wrappings of the tape which goes beyond it. (See fig. 31.)

■ 188. WIRE TIES.—Field wire lines usually terminate at the binding posts of a terminal strip or an instrument. Obviously, any strain placed on the wire tends to pull it away from the binding posts. To avoid this, the wire is securely fastened to a convenient tree, pole, or other support before connecting it to the binding posts. Wire lines are also tied in at various points along the route where it is necessary to hold the wire in place. The kind of tie used to secure field wire to any object depends upon the nature of the object; *a* to *e* below, inclusive, describe several kinds of ties which should meet all conditions in field wire line construction. Where the wire is tied above equip-

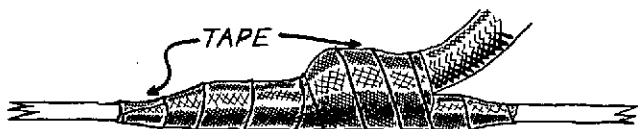

TL-696-2

FIGURE 31.—Taping an insulated conductor spliced to bare wire.

ment to which it is to be connected, such as a telephone or terminal strip, a drip loop is made in the wire. To make a drip loop, bend the wire in the slack part between the tie and the connection downward into a hanging loop. (See figs. 32 and 33.) Water running down the wire will drip off from the bottom of the loop and will not be led to the terminal strip or instrument where it might cause a short circuit or damage to the equipment.

a. Tying-in field wire to open wire (fig. 34).—Stranded wire is normally spliced to solid conductor wire only where it is necessary to connect a field wire to an open wire pole line. In this case, the stranded wire is tied in to the cross arm or pole, but never to the metal brace, near the point where the splice is to be made, and a little slack is left between the tie and the splice. The tie should take the strain, since the splice is not strong enough to withstand a heavy pull.

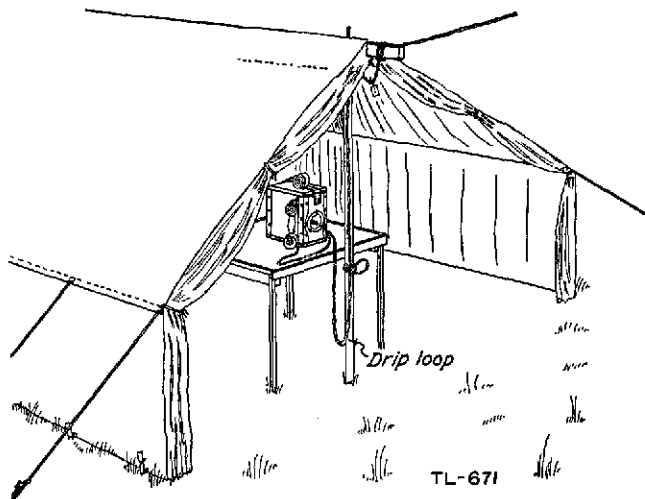

FIGURE 32.—Field telephone installed in a tent.

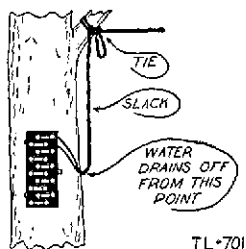

FIGURE 33.—Drip loop in wire leading to a terminal strip.

b. Clove hitch tie.—When the end of the object to which the wire is to be tied is exposed so that the wire may be placed over it, the clove hitch tie is used. To make the tie, make two loops in the wire as shown in figure 35*a*. Place the right-hand loop on top of the left-hand loop without turning either loop as shown in figure 35*b*. Place both loops over the object to which the tie is to be made and pull them tight as shown in figure 35*c*.

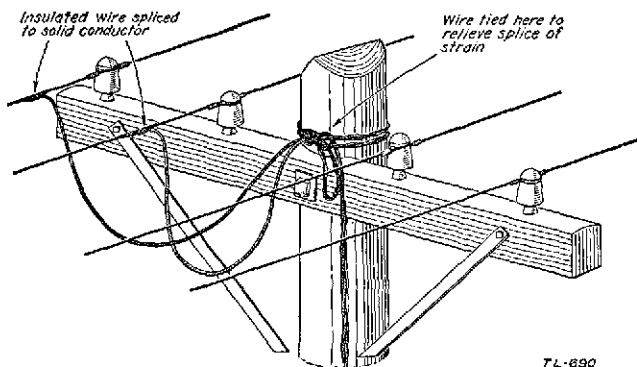

FIGURE 34.—Tying-in field wire to open wire.

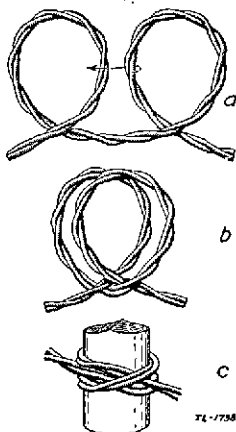

FIGURE 35.—Clove hitch tie around a stake.

c. Other knot ties.—When the end of the object to which the wire is to be tied is not exposed, one of the three ties described below is used. All three permit tying the wire without cutting it. For simplicity, figures 36 and 37 show only one of the two conductors of the field wire. In each of those figures the standing part is the portion of the line which has already been laid, and the running end is

the portion leading to the wire-laying equipment. A bight is a loop formed on the wire so that the two parts of the loop lie alongside of one another.

(1) *Loop knot tie*.—This tie is more easily and quickly made than are the ones described in (2) and (3) below but it is not as secure. Consequently, it is not used in very long spans, at overhead crossings where increasing sag resulting from slipping of the tie might endanger traffic, or where it might be untied accidentally by passing personnel, vehicles, or animals.

(a) 1. To make the tie, stand facing the object on the side on which the wire is being laid. Pull in enough slack to make a bight to go around the object with about 2 feet of bight left over. If, during tying, the greater strain is on the standing part, place the bight around the object from the front, going around the side toward which the wire is being laid, and returning to the front on the side from which the wire has been laid. If the greater strain is on the running end, place the bight around the object from the front in the opposite direction. Bring the bight under and then over both the standing part and the running end, forming the front V opening shown in figure 36. Reach through this opening and pull through it about 6 inches of the doubled bight as shown in figure 36b. Tighten the tie, being sure that it rests against the object.

2. An alternate satisfactory loop knot tie may also be made as follows (fig. 36c, d, e, and f): After placing the bight around the object as in 1 above, hold the bight in the left hand, passing the right hand under the standing part and running end, and grasping the bight with the right hand palm up; turn the hand in a counterclockwise direction, pulling the loop under the standing part and running end; double the bight and pass it over the line and into the loop, pulling the bight until the knot is tight and against the object.

(b) To untie the tie, pull the free end of the bight through the opening. The wire will fall away from the object.

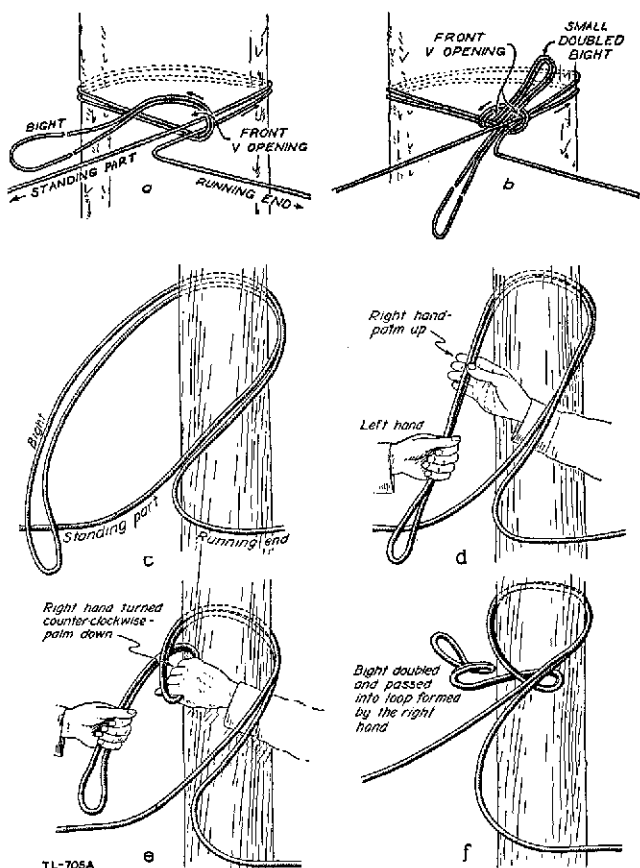
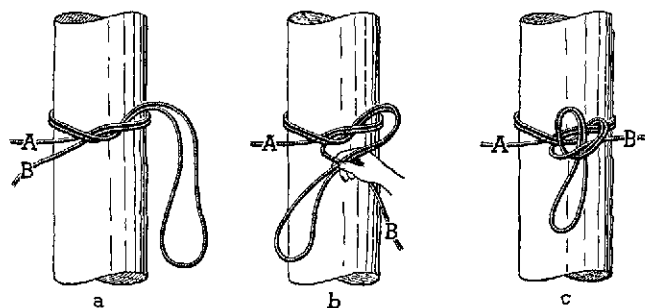

FIGURE 36.—Loop knot ties showing only one of the two conductors.

(2) *Square knot and loop tie.*—This tie is used in long spans, at overhead crossings, and when a tie is desired which will remain secure for a longer time than the one described in (1) above.

(a) To make the tie, begin as in (1) (a) 1 above, but bring the bight over both the standing part and the running end, and then between the object and the turn around it, as shown in figure 37a. Draw this knot up tightly against the object. Bring the bight over the running end, forming the opening shown in figure 37b. Reach through this opening and pull through it about 6 inches of the doubled bight as shown in figure 37c. Tighten the tie by holding the doubled bight in one hand and pulling the running end with the other.

(b) To untie the tie, pull the free end of the bight through the opening and then untie the bight from the object. The wire will fall away from the object.



A—Standing part
B—Running end

TL-1724

FIGURE 37.—Square knot and loop tie, showing only one of the two conductors.

(3) *Square knot tie.*—This tie is used when a tie is desired which will remain secure for a longer time than those described in (1) and (2) above.

(a) To make the tie, proceed as in (2) (a) above but pull the end of the bight through the opening and tighten it by holding the end of the bight in one hand and pulling the running end with the other. It is shown in figure 53.

(b) To untie the tie, reverse the procedure in (a) above. After it has remained in place for some time under a strain, it is more difficult to untie than are the ties described in (1) and (2) above.

d. Knob tie (fig. 38).—The knob tie is used in tying field wire to a knob or insulator. It is not suited to tie over larger objects. To make the tie, form a loop in the wire. Separate the two conductors in the loop and bend each back around its side of the length of wire, so that they again touch each other 180° opposite the original position of the loop. Place the loop over the knob and draw it tight.

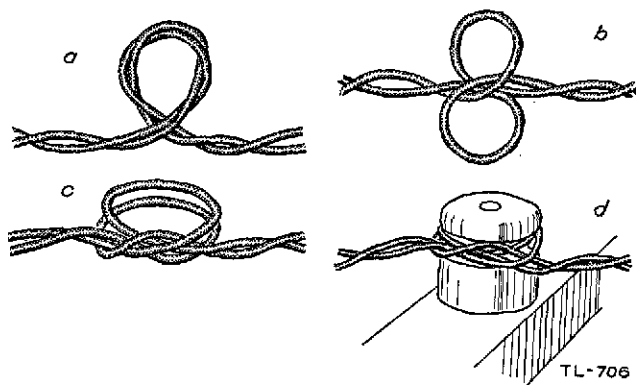

FIGURE 38.—Knob tie.

e. Marline tie.—The marline tie may be used where it is necessary to tie to a knob, crossarm, or other support. It is desirable when the object to which the wire is to be tied might damage the insulation if the wire were tied to it otherwise. To make the tie, take a piece of marline which, when doubled, will reach from the wire in its suspended position twice around the support and down to the wire again, with about 4 inches left over for tying. Insert the ends through the loop formed in the middle of the marline and draw the marline tight around the wire as shown in figure 39*a*. Pass the doubled marline twice around the support and back to the wire as shown in figure 39*b*. Tie it securely to the wire with a double overhand knot. To tie this knot, place the marline around the wire and pass the running ends over the standing part to form a loop. Then pass the

running ends down through this loop as shown in figure 39c. Draw the knot tight.

■ 189. CIRCUIT MARKING TAGS.—A field wire circuit is identified by means of a designation appearing on a tag tied to the wire. The tag should be of rope stock or other fairly

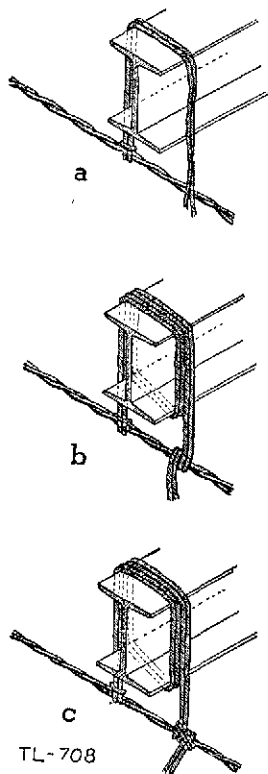

FIGURE 39.—Marline tie to a metal support.

waterproof substance which will show the marks made by a soft pencil or crayon. A short length of soft iron wire is fastened to one end of the tag for attaching to the circuit wire. (See fig. 40.) The tag is fastened to the wire about

a foot from where the wire is connected to an instrument or terminal strip. Tags are also required at frequent intervals along the wire, particularly where circuits parallel each other for a long distance, at points where some circuits leave the main route, and at points where the type of construction changes, as from surface to overhead. Trunk circuits are tagged with the complete designation of the circuit. (See par. 174.) Local telephone circuits are tagged with the local

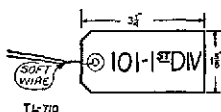

FIGURE 40.—Circuit marking tag.

telephone number. Telegraph legs are tagged with their local number and the unit to which they lead, as TG-1 to 1st Brig., TG-2 to 2d Brig., etc.

■ 190. **TERMINAL STRIPS.**—*a. Description.*—A terminal strip is a block of insulating material to which are fastened a number of binding posts. The binding posts are connected in pairs by metal strips, so that a wire connected to a binding post on one side will be joined electrically to another wire that is

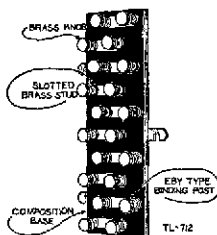

FIGURE 41.—Terminal strip TM-84-A.

connected to the corresponding binding post on the opposite side. The type commonly used for field wire systems is the terminal strip TM-84-A which will handle five pairs of wire. (See fig. 41.)

b. Connecting a wire to a terminal strip (fig. 42).—To make the connection, skin off about $\frac{1}{2}$ inch of insulation from the end of the wire to be connected. Open the slot in

the binding post to its fullest extent by unscrewing the knob with the fingers. Insert the end of the wire into the slot so that it projects through the binding post. As an alternative satisfactory method, skin off about 1 inch of insulation from the wire, leaving about 1 inch of insulation on the end, double the bared portion, and insert it into the slot. Tighten the knob firmly with the fingers, clamping the wire securely in the slot so that a good electrical contact is secured. Do not use pliers to tighten the knob as the threads on the binding post may become stripped.

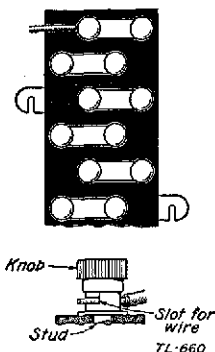

FIGURE 42.—Wire connected to terminal strip TM-84-A.

■ 191. POLE CLIMBING EQUIPMENT.—*a. Description.*—In making overhead installations the ability to climb poles and trees is necessary. The lineman's equipment for pole climbing includes a pair of climbers and a lineman's belt with safety strap for use while working on the pole. Each climber is provided with a top and a bottom strap. The top strap is equipped with a leather pad to prevent the upper end of the climber from chafing the leg. The belt is equipped with loops for carrying tools and two rings to which the safety strap is fastened. The tools usually issued as part of the lineman's equipment include an ax, sidecutting pliers, screw driver, lag wrench, and a splicing clamp.

b. Inspection.—(1) Before using climbers they should be examined for broken, loose, or improperly sharpened gaffs.

Gaffs should be not less than $1\frac{1}{8}$ inches in length measured along the inside surface. They should be kept sharp at all times by filing flat on the inside surface. The shape of the outside surface should not be changed. The five dimensions of the gaff that should be checked are the length, the width at distances of $\frac{1}{2}$ inch and of 1 inch from the point, and the thickness at distances of $\frac{1}{2}$ inch and of 1 inch from the point. These dimensions may be quickly checked by means of the gaff gage which is a piece of sheet steel $2\frac{1}{4}$ inches in length, bent to an L shape with slots, openings, and reference lines. (See fig. 43.)

(2) To check the length of the gaff, place the gage against the flat surface of the gaff with one edge tight

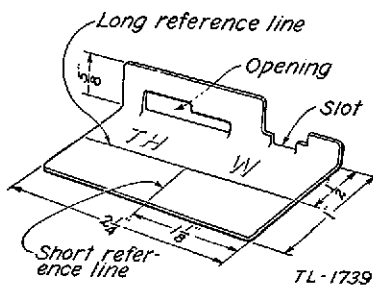

FIGURE 43.—Gaff gage.

against the crotch. If the point of the gaff extends to or beyond the short reference line at the middle of the gage the length is satisfactory.

(3) To check the width of the gaff, place the gaff first in the smaller and then in the larger of the slots marked W, sliding the gage toward the crotch as far as it will go. If the point of the gaff does not extend beyond the long reference line when in the small slot or beyond the far edge of the gage when in the large slot, the width is satisfactory. The thickness is checked in the same manner as the width, using the openings marked TH instead of the slots marked W.

(4) Climber straps and safety belts should be examined before use for cracks, cuts, tears, broken stitching, worn

places, or any other defect that would be likely to affect the strength of the leather; also for broken or defective buckles, snaps, or D rings.

(5) Leather belts and straps should be kept soft and pliable by the use of saddle soap or by washing with a neutral soap and oiling with neat's-foot oil. Mineral oils or greases should not be used. AR 30-3040 contains instructions for the care and treatment of leather. Climbers should be kept clean and free from rust. In the field a light coating of oil is desirable.

c. Size and adjustment (fig. 44).—Climbers are furnished in various sizes, the size being the length from the instep to the end of the leg iron. The correct size of climber to use is one which is $\frac{1}{2}$ inch less in length than the distance from the projecting knee bone to the arch of the shoe. Climbers should be fitted to the leg so that they are comfortable with both straps fastened snugly around the leg. Care should be taken that the buckles do not rest on the shin bone or on the instep. The belt should fit loosely around the body but should be sufficiently tight to prevent its slipping down over the hips. Both ends of the safety strap should be snapped to the D ring on the left-hand side of the belt. *Climbers should not be worn except while actually engaged in climbing or working on poles, as serious injury may result if they are worn while doing work on the ground.*

■ 192. POLE CLIMBING.—*a. To ascend.*—Take a natural standing position at the foot of the pole with the toes about 6 inches from the pole. Raise and extend the arms to a horizontal position, grasping the pole with the palms of the hands and allowing the body to lean backward the full length of the arms. Raise the right foot about 10 inches from the ground, keeping it about 1 inch from the pole, and with a downward thrust engage the gaff of the climber in the face of the pole about 8 inches from the ground. (See fig. 45 ①.) Lift the body by straightening the right leg and placing the weight on the gaff which is engaged in the pole. Let the left leg hang free and keep the body away from the pole. (See fig. 45 ②.) From this position raise the

left foot about 8 inches, keeping it in against the pole, and repeat the thrust as before. (See fig. 45 ③.) At the same time raise the left hand about 10 inches on the pole, balancing the body with the right hand and keeping the arms

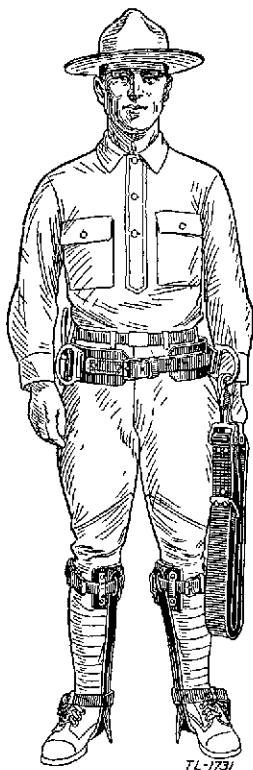
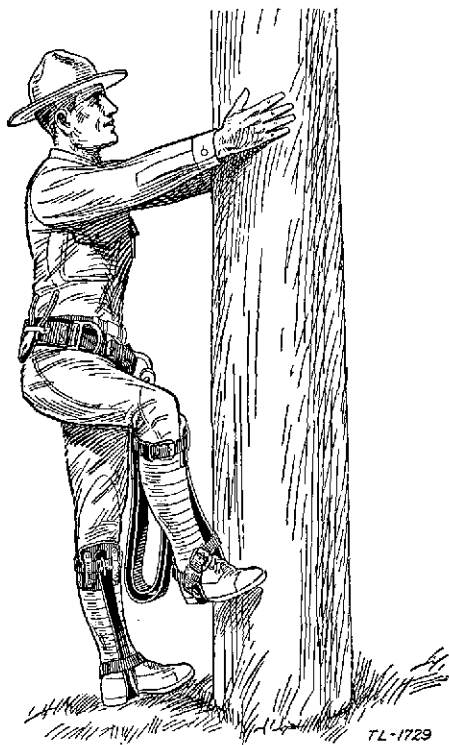

FIGURE 44.—Method of wearing pole climbing equipment.

straight and the body well away from the pole. Continue the climb in this manner to the desired height.

b. Working on the pole.—When sufficient height has been attained on the pole so that the required work can be done in a natural position without stretching, thrust the gaff of

the right climber into the pole and shift the weight of the body to the right foot. Pass the left leg around the pole in such a manner as to aid the right hand in supporting the body, keeping the right knee well away from the pole. With



① First position.

the left hand unsnap one end of the safety strap and pass the end around the pole to the right hand. (See fig. 46 ①.) Aid the support of the body with the left hand on the pole again, and with the right hand snap the end of the safety strap to the right ring on the belt. (See fig. 46 ②.) Clasp the pole with both hands. Remove the left leg from around

the pole and with a downward thrust engage the gaff of the left climber in the pole on a level with the right foot. Keep the heels about 3 inches apart. Lean backward gradually, placing the weight of the body on the safety strap, figure 46 ③,

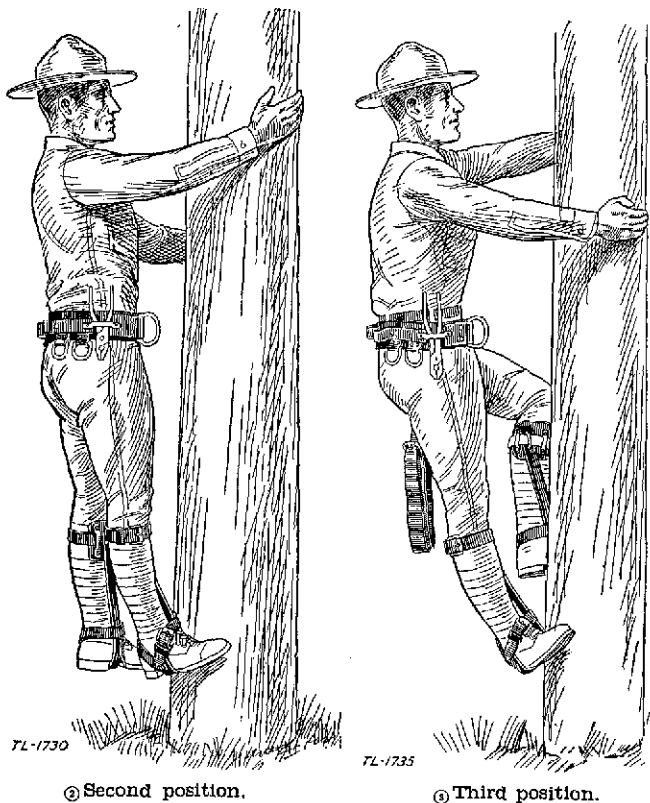
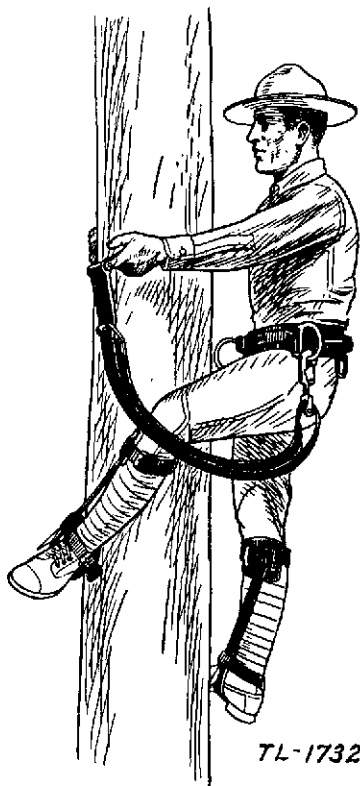
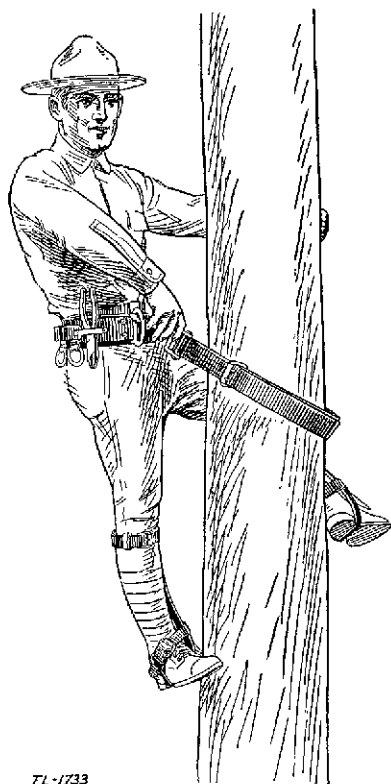

FIGURE 45.—Pole climbing.

and adjust the safety strap to its proper position on the pole. Both hands and arms should now be free to work easily and comfortably on the pole.



⊙ First position.



② Second position.

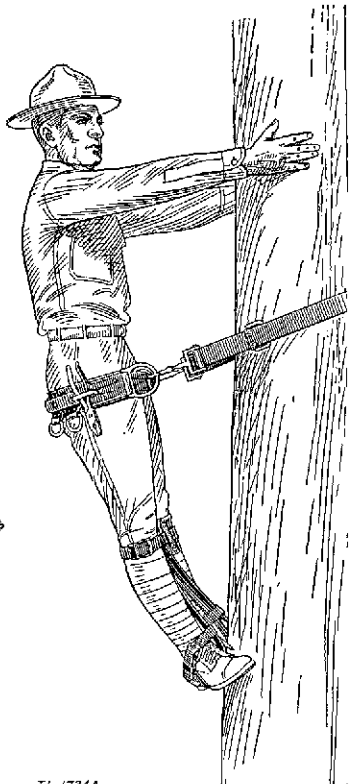

③ Third position.

FIGURE 46.—Using safety strap.

c. *To descend.*—Unhook the safety strap, using the above procedure in the reverse order. Climb down with short steps, throwing the weight of the body slightly on the right and left leg alternately to engage the gaffs firmly.

■ 193. WIRE LAYING EQUIPMENT.—Field wire is carried forward and laid by motor trucks or wagons carrying reel units; reel carts, hand drawn or towed; reels carried by hand on axles; and bundles or coils of wire carried by hand, depending on the condition of the roads and terrain, traffic conditions, and the tactical situation.

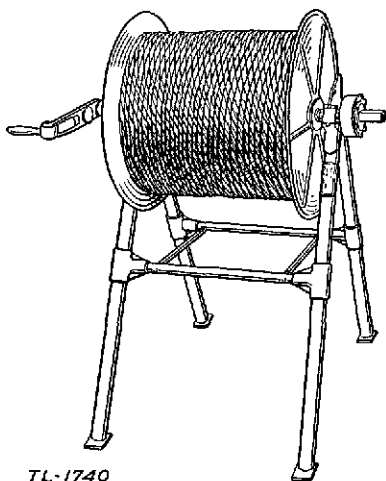

TL-1740

FIGURE 47.—Reel unit RL-31 with reel DR-5.

a. *Reel unit RL-26.*—The reel unit RL-26 is a transportable wire laying and wire recovering device primarily intended for temporary or permanent installation in and operation from a variety of vehicles such as trucks and wagons. For the description, operation, and maintenance of the reel unit RL-26 see TR 1220-5.

b. *Reel unit RL-31* (fig. 47).—(1) The reel unit RL-31 is a lightweight portable frame and mounting designed to facilitate the reeling and unreeling of field wire by hand. It uses either one reel DR-5 or two reels DR-4.

(2) The reel unit may be set up on the ground, mounted in a vehicle, or secured to the tailboard thereof. It may also be used as a carrying frame, similar to a litter, for use by two men using carrying straps to help support the weight of the frame and reel. One man may use it as a rolling frame in wheelbarrow fashion.

(3) The reel unit consists of a folding tubular aluminum alloy frame with bearings for a steel axle equipped with a removable crank for turning by hand. A brake unit is provided to prevent the reels from overspinning while unreeling. Two tailboard hangers with bolts are provided to facilitate mounting the reel unit on the tailboard of a truck or wagon. Four toe plates are provided to hold the reel unit securely in place when it is mounted on the floor of a truck or wagon.

c. Axles RL-27 and RL-27-A (figs. 48 and 49).—The axle RL-27 is a simple form of wire laying device which was

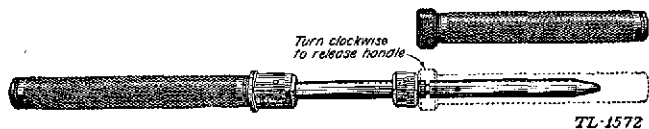

FIGURE 48.—Axle RL-27 showing removable handle.

designed to replace the breast reel and hand-drawn reel cart within the infantry division. It is intended for use in laying short local circuits, and sometimes trunks or long locals where conditions do not permit the use of other wire laying equipment. The axle RL-27 is a machined steel bar, about 2 feet long, with two knurled aluminum handles, one of which is permanently fixed to the bar. The other can be removed to permit placing a reel DR-4 on the axle. The reel DR-5 will not fit on the axle RL-27 because of the greater width of this reel. The axle RL-27-A is a modification of the axle RL-27 with an improved type of roller bearings.

d. Reel cart RL-16 (fig. 50).—This is a hand-drawn reel cart for use within the division. It may be pulled by hand or may be towed behind a communication cart. It should not be towed behind a fast moving vehicle. Each reel cart

carries two reels DR-4. The reels are removable and can be replaced when empty. The axle is equipped with a detachable hand crank for recovering wire on the reels. The cart may be taken apart for packing.

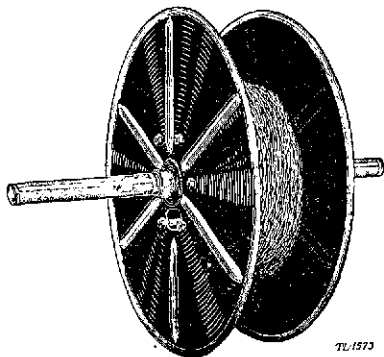

FIGURE 49.—Axle RL-27 with reel DR-4.

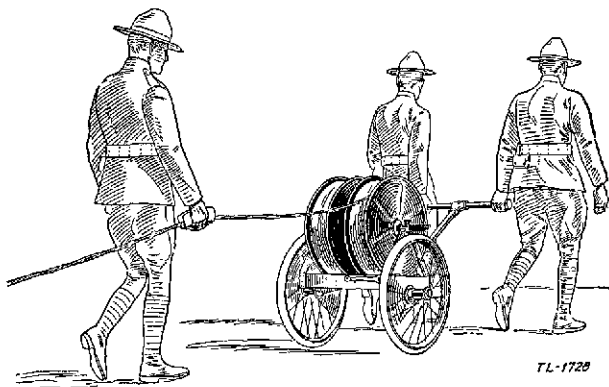

FIGURE 50.—Reel cart RL-16.

e. Commercial spools.—If wire is issued on commercial wooden spools, it may be laid by inserting an iron bar through the axial opening in the spool and paying it out from a truck or wagon, or two men may carry the spool on the bar and pay out the wire while walking along the route.

■ 194. PROTECTION OF WIRE.—After the wire has been laid, it should be removed promptly from the path of vehicles or traffic in order to protect it and insure its continued use. The wire laying device should be followed by personnel who place the wire in the desired position by hand or by the use of wire pikes.

■ 195. RECOVERY OF WIRE.—In the recovery of wire, the recovering equipment should be preceded by linemen, who with the use of a wire pike or by hand place the wire back in the path of the equipment. Leather gloves or pads should ordinarily be used for protection while handling field wire. The normal way to recover wire is to proceed along the line and wind up the wire en route. Under certain conditions it may be advisable to leave the recovering equipment stationary and drag in the wire by turning the reel. This causes more wear on the insulation and may cause the wire to break.

■ 196. ROUTING OF WIRE LINES.—*a.* The signal or communication officer prescribes the general route to be followed. The chief of construction is usually allowed considerable latitude in the selection of the actual route.

b. Maintenance is facilitated to the extent of conserving personnel by using the minimum number of routes. However, vulnerability of the lines is likely to be increased, and complete interruption of wire communication may result unless the route chosen is particularly well protected from the hazards of traffic and shell fire. In general, where more than one circuit is to be laid to a unit, vulnerability may be decreased and continuity of wire communication better insured by varied or alternate routes. The route or routes selected are determined largely by the time and the equipment available for laying the wire. Routes should afford cover from hostile observation and fire for the protection of the circuits and personnel during construction and subsequent maintenance. Main traffic routes, shelled areas, and areas over which tanks or tractors are likely to pass should be avoided wherever practicable. It is also desirable that lines should be routed so that they can probably be used by the same or another friendly unit after the movement of command posts.

■ 197. CONSTRUCTION ORDERS.—*a.* The chief of construction is given orders prescribing the number of circuits to be installed, the priority of installation, and the action to be taken upon the completion of the installation. He should receive or obtain the following descriptive information relative to each circuit to be laid:

- (1) Circuit number.
- (2) Route.
- (3) Whether a trunk or a local circuit.
- (4) Whether a metallic or a ground return circuit.
- (5) Type of wire.
- (6) The centrals which it will connect and test stations it will pass through, including the telephone directory names of the organizations served.
- (7) Approximate length.
- (8) Type of construction.
- (9) Nature of roads and terrain.
- (10) Precautions to avoid damage by friendly troops and transportation.
- (11) Tests and reports required.

b. This information is best imparted by use of a line route map and circuit diagram supplemented by oral or written instructions from the signal or communication officer. These instructions always include orders as to the disposition of the construction detail after the construction specified has been completed.

■ 198. PROCEDURE IN LAYING FIELD WIRE.—*a.* Whenever possible the construction chief makes a personal reconnoissance of available routes before starting the construction. During this reconnoissance the following features of the routes are noted:

- (1) Number of overhead crossings.
- (2) Number of underground crossings.
- (3) Number of railroad crossings.
- (4) Number of stream crossings.
- (5) Types of roads found and the wire laying equipment and type of construction best adapted to each.
- (6) Distances in miles.
- (7) Concealment for wire parties during construction and subsequent maintenance.

(8) Any obstacles to maintenance.

(9) Alternate routes to avoid gassed or shelled areas or other unfavorable road conditions found.

b. The exact route and the side of the road along which the wire is to be laid which offer the least difficulty of construction and maintenance are then selected

c. The wire for the circuits is tested before starting to insure the continuity of each reel. Reels of wire which do not show a continuous circuit when tested are not used until the wire has been serviced (par. 242).

d. At the starting point, the free end of the wire is tagged with the circuit designation (par. 189). This tag is placed a foot from the end of the wire.

e. Sufficient wire is left at the free end to reach the switchboard terminal strip or other installation, and the wire is tied in to some fixed object.

f. The free end of the wire is connected to the switchboard terminal strip if installed. If a switchboard is to be installed later, the wire is connected to a telephone or other instrument which may be used in making tests on the circuit until the switchboard has been installed.

g. The chief of construction then directs the laying of wire over the detailed route, determined as in *b* above, following the general route prescribed by the signal or communication officer (par. 196). He causes a test to be made back to the starting point from the far side of each splice after it is made, in order to insure continuity of the circuit. When connections are made at terminal strips he causes a test to be made from the far side of the connection back to the starting point.

h. When the wire has been laid to the designated point it is tied in and tagged, leaving a free end with sufficient slack to run to the switchboard terminal strip. The circuit is then tested and turned over to the operating detail who connect it to the switchboard terminal strip or to an instrument. The chief of construction calls back over the completed circuit to report the installation. This call is placed through the switchboard or other instrument if installed, so that any fault in the terminal connections may be discovered and corrected before the circuit is reported.

i. Should the wire be laid to any location where a central is to be installed, but where the operating detail or the equipment for the installation has not yet arrived, the chief of construction calls back over the circuit in order to verify his proper location and to ask for instructions. In the absence of other instructions, the construction chief leaves a member of the construction detail at the wire terminal with a telephone connected to one circuit. This member informs the arriving personnel of the location of the circuits and assists in making the terminal connections. After the terminal apparatus has been connected, he makes a test back and reports over each circuit. Sufficient slack is left at these terminals to permit extending the circuits to the probable location of the central to be selected by the operating detail upon arrival.

■ 199. CONSTRUCTION AND REMOVAL OF TEST STATIONS (par. 171).—*a. Construction.*—Test stations are constructed when the wire lines are initially laid or are installed on the lines later, and are removed when their use is no longer advantageous. The site selected for the location of the test station should afford cover from hostile observation and fire and protection from friendly troop movements, and should be accessible for testing. A station consists of one or more terminal strips. The circuits are connected to pairs of binding posts on the right-hand side of the terminal strip. Circuits are cut through the test station by jumpering the corresponding binding posts on the left-hand side of the terminal strip. The jumpers for this purpose are pieces of flexible insulated wire. The terminal strips are fastened to a support such as a tree or fence post. The wire circuits are tagged and tied in before being connected to the binding posts.

(1) *During initial installation of wire lines (fig. 51).*—Locate the site of the test station. Lay wires to this location. Tag and tie in circuits near the terminal-strip position. Secure the terminal strip or strips to a support. The number of strips used depends upon the number of circuits entering and leaving the test station, as there must be a pair of binding posts for each circuit. Connect the lowest numbered circuit entering the test station to the

top right-hand pair of binding posts on the terminal strip. Connect the next lower numbered circuit to the next lower pair of binding posts and continue in this manner until all are connected. The wires extending forward from the test station are laid, being tied in near the terminal strip. Connect the lowest numbered of these circuits to the pair of binding posts at the top of the lower half of the terminal strip, and so on until all are connected. When an even number of terminal strips is used, the number of pairs of binding posts will be even and can be evenly divided into an upper and lower half. If the number is odd, the number of pairs of binding posts will be odd. In this case, leave

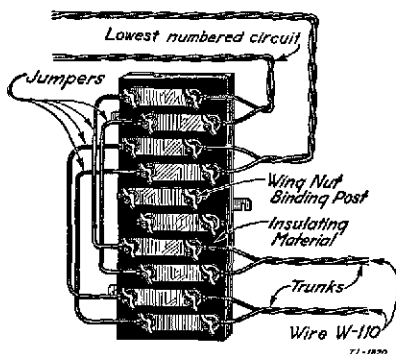

FIGURE 51.—Test station constructed during initial installation of wire lines.

the odd pair between the upper and lower halves vacant. Take jumpers, prepared from lengths of flexible insulated wire, which are sufficiently long to reach from the top binding post to the lowest binding post. Connect the proper circuits together. A telephone or other suitable instrument is connected to the designated test circuit as prescribed in section V.

(2) *After initial installation of wire lines.*—(a) Locate the site of the test station along the route of the line. Secure the terminal strips to a support. Take the lowest numbered circuit and pull in slack on the wire. Tie in the wire near the terminal strip. At a point where the wire

reaches the terminal, strip off about 2 inches of insulation from one wire and attach it to the top right-hand binding post. Remove the same amount of insulation from the other wire and connect it to the lower binding post of the pair as shown in figure 52.

(b) Measure off a sufficient length of wire to reach to the binding posts of the pair from which the circuit is to leave the terminal, and after removing the insulation as before connect the wires to these binding posts in the same order. Tie in the wires near the strip. Connect jumpers to the corresponding binding posts on the left-hand side of the terminal strip. Remove the loop in the circuit wire between the upper and lower pair of binding posts, cutting

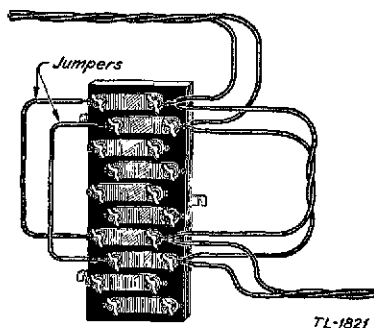

FIGURE 52.—Test station constructed after initial installation of wire lines.

the wire close to the binding posts. Cut in other circuits to the test station terminal strip in a like manner. Beginning at the top with the lowest numbered circuit, cut in circuits in numerical order.

b. Removal.—When a test station is to be abandoned, it is the usual practice to leave the terminal strip connected. It may happen that, due to shortage of terminal strips, it is necessary to remove the terminal strip and splice the circuits through. Before removing any circuit from the strip, the lineman on duty at the test station first listens in on it and satisfies himself that it is not in use. He then calls on the circuit and notifies the switchboard operator that the test

station is to be removed and the circuits cut through. Then, taking two wires that are connected together by the same jumper, he removes them from the binding posts and splices them together. The other wires of the pair are then spliced in a like manner. Other circuits are removed from the strip and spliced similarly.

■ 200. SURFACE LINE CONSTRUCTION.—During movement of units in combat, field wire lines are laid hastily on the ground. This type of wire line is termed a surface line. Surface lines must be protected from traffic at command posts, road crossings, or other places where the lines cross traffic lanes (par. 209d). Surface lines are laid loosely in order that the wire may be flat on the ground and sufficient slack provided for repairing breaks and facilitating subsequent changes in the type of construction. At suitable intervals, surface lines are tied in to objects such as trees or posts in order to leave sufficient slack and to prevent passing troops and transport from pulling the wire into traffic lanes. The wire is tied to the tree or post at ground level. (See fig. 53.) When surface lines are routed along a road, the wires must be kept off the traffic lane. If the road curves in one general direction, the line should, if practicable, be routed along the inside edge of the road. Advantage should be taken of objects such as trees or posts along a curve in the road to prevent the wires from being pulled into the traffic lane. (See fig. 54.) Connections between surface lines and pole lines are preferably made at existing terminals of the pole line. If such terminals are not conveniently located, a test station may be established. When surface lines connect with overhead construction, the surface line must be securely tied and tagged at the base of the pole at which the connection is made, and tied again just above the crossarm or terminal where the connection is to be made. Connections to aerial or buried cables are made only at standard cable terminals.

a. Advantages.—(1) Surface lines require minimum time for installation.

(2) When loosely laid they are less vulnerable to artillery fire than are other types of construction.

b. Disadvantages.—(1) Surface lines may become unserviceable in wet weather due to leakage to ground.

(2) They are often broken by passing troops and transport.



FIGURE 53.—Method of tying wire at ground level; (a) correct, (b) incorrect.

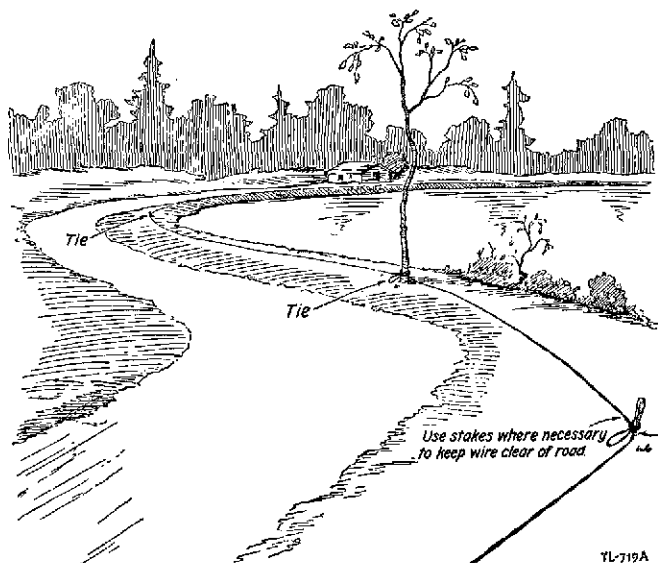

FIGURE 54.—Method of tying wire along curve in road.

■ 201. OVERHEAD CONSTRUCTION.—Field wire lines are placed overhead by fastening the wire to trees or existing poles at a height of 14 feet above the ground by means of standard field wire ties. This type of construction is employed near

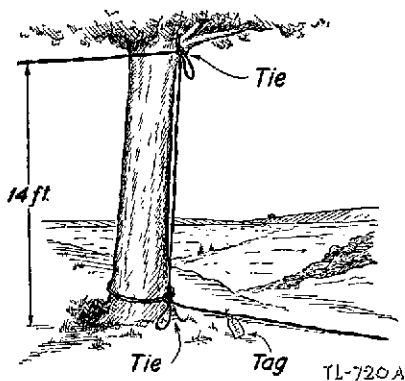

FIGURE 55.—Method of tying wire at junction of surface line with overhead construction.

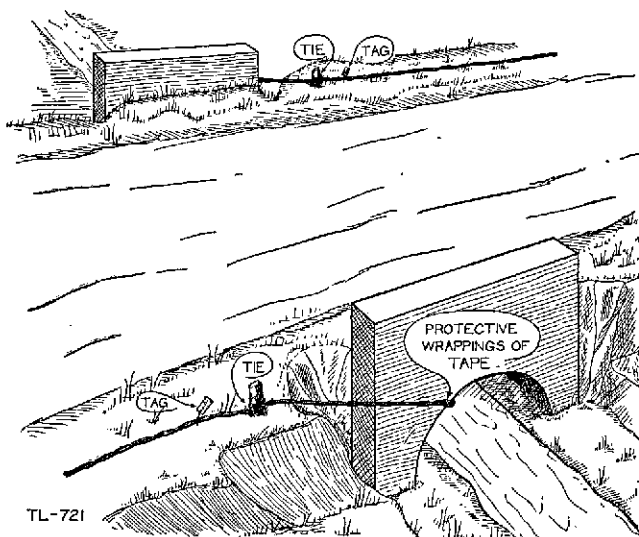

FIGURE 56.—Wire crossing road through culvert.

command posts, test stations, and along roadways at points where traffic is likely to be diverted from the roads. At junctions between overhead and surface line construction, the wires are tied securely to the bottom of the support and tagged. (See fig. 55.) Test stations should be installed generally at the junctions of long overhead lines with other types of construction.

■ 202. ROAD CROSSINGS.—*a.* Where a road crossing is necessary, field wire lines should cross through a culvert if possible. The wires are passed through the culvert, tagged, and tied at the entrance and exit to prevent contact with water. (See fig. 56.)

b. Wires which must cross roads overhead must clear the crown of main traffic arteries and paved roads by at least 18 feet, and of other roads by at least 14 feet. When a surface line crosses a road on poles or other objects, the wire is tied at the base and at the top of the object on each side of the road and tagged at the base. The strain which occurs along the line is met by the tie at the base. (See fig. 57.)

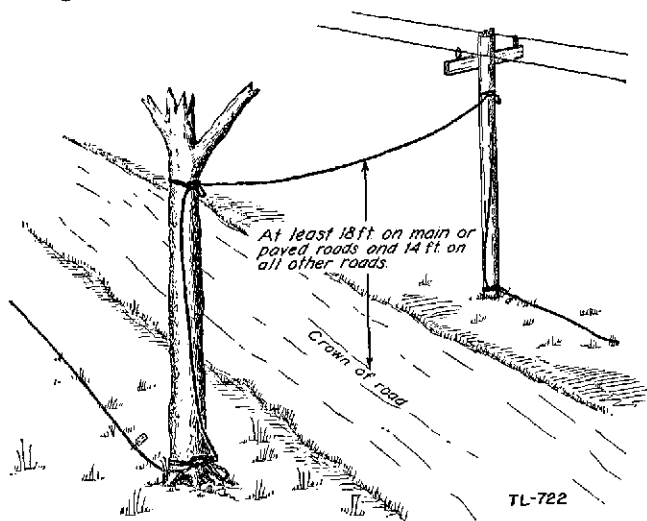

FIGURE 57.—Wire crossing road overhead.

c. If neither of the above methods can be used, the wires are buried in a trench crossing the road at right angles. The wires are laid snug, tagged, and tied to a stake at each end of the trench to prevent their being pulled out. A sufficient amount of slack wire is left at each side of the road to permit replacement of the portion under the road, should it become worn or water-soaked. (See fig. 58.)

■ 203. RAILROAD CROSSINGS.—Railroad yards should be avoided by skirting them. If a bridge or culvert is available, it should be used in making the crossing even if neces-

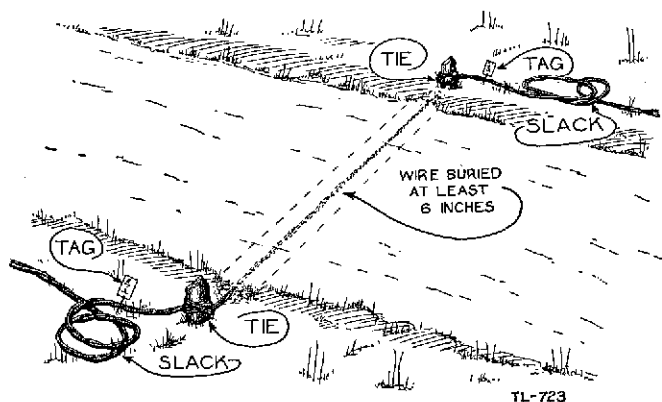
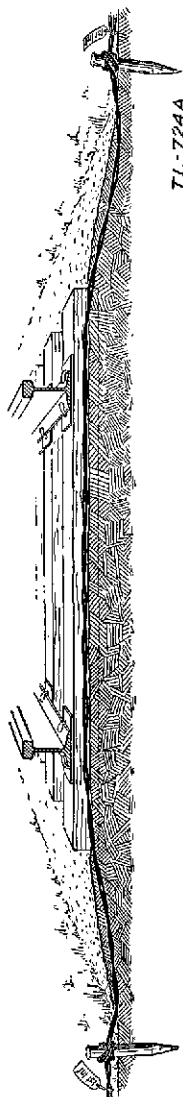

FIGURE 58.—Wire crossing under road in trench.

sary to parallel the tracks with the wire for some distance in order to reach it. If a bridge or culvert is not available, field wire lines should cross railroad tracks under the rails, never overhead. The wires are pulled tight and buried outside the rails to a point beyond the shoulders or improved strip along the tracks, and secured on both sides to prevent them from being pulled out and becoming a hazard to trainmen.

■ 204. RIVER CROSSINGS.—*a. Overhead.*—Small stream crossings are made in the same manner as overhead road crossings, except that the wires need be only high enough to clear traffic. A span of more than 150 feet should not contain a



7L-724A

FIGURE 59.—Wire crossing under railroad track

splice. Long spans up to 250 feet can be made with field wire, but special construction is necessary for resisting the strain.

b. Submerged.—When field wire lines must cross bodies of water, such as rivers, where it is impracticable to make overhead crossings, the wire should be submerged. The wire is tied in securely on the near bank, laid by paying out from a reel or coil, and tied in securely on the far bank. The ties are made above the highest level reached by the water. The insulation on the wire should be sound. Splices should be made only if absolutely necessary and should be made as waterproof as possible. If the current in the stream is strong, or if the stream is navigable, the wire is weighted at suitable intervals to keep it submerged to the full depth and to retard its movement by the current. The amount of wire necessary for the crossing is carefully computed and the wire prepared in advance so that splicing in midstream is avoided.

■ 205. TRENCH LINE CONSTRUCTION.—In defense, field wire lines are often installed in trenches, two kinds being generally used—wire trenches constructed for the purpose, and trenches that are constructed primarily for other purposes, such as fire or communication. Trench wire lines are tagged at intervals of not more than 150 feet or at junctions with other lines.

a. Wire trenches (fig. 60).—(1) Wire trenches vary in size from 10 inches wide by 10 inches deep to 36 inches wide by 30 inches deep. They afford considerable protection from shell fire but offer an obstacle to friendly traffic. The wire may be fastened to cross arms which are attached horizontally to short poles or rest against or project into the sides of the trench. Instead of using cross arms the wire may be fastened to the sides of vertical poles. Field wire may be tied directly to these supports with wire or marline, but it is preferable to tie the wire to wooden or porcelain knobs or insulators.

(2) The wire trench route should be chosen with a view to concealment, cover, and ease of construction. The number of trenches is kept to a minimum, and the wire is kept in the main trunk-line trenches as much as practicable.

Switching centrals may be installed at important trench junctions.

(3) In digging the trench, the workers are divided into groups of two men each, each group equipped with a pick and shovel. Two men can dig from 15 to 35 lineal yards of trench per day in good ground, depending on the type of trench.

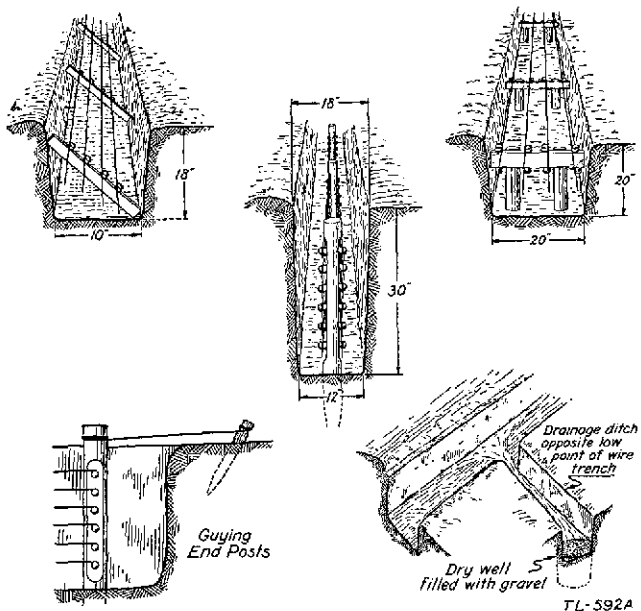

FIGURE 60.—Wire trench construction.

(4) Trench posts are set in the ground at intervals of 15 to 25 feet. They are guyed at turns and at the ends of the line. When fastening wire to vertical poles, insulators may be nailed on opposite sides of each pole. As many as 14 twisted pairs can be carried on a single pole line of this type in a trench about 30 inches deep. A liberal allowance of wire should be made for sag.

(5) Trench lines may be terminated by running directly into a telephone central or test station or connecting to some other type of construction.

(6) When necessary to cross a road with a wire trench, the line should preferably be placed in a buried conduit of wood, clay, or iron. If this is impracticable, the wires should be carried overhead on poles.

b. Fire or communication trenches (fig. 61).—(1) When it is impracticable to construct wire trenches, field wire may be installed in fire or communication trenches. This will be normal within the intrenched area of the infantry regiment. Owing to the great use made of these trenches by combat troops, they are not satisfactory except for temporary wire installations.

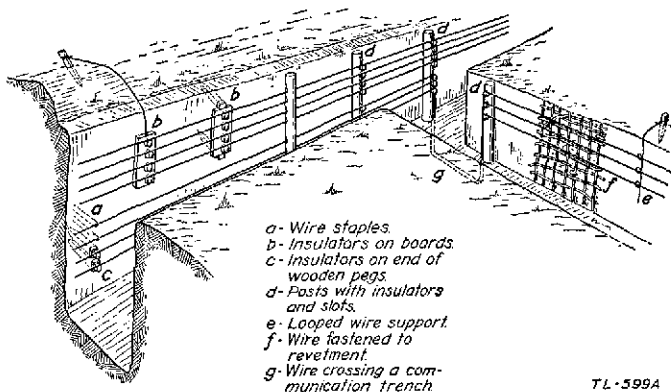

FIGURE 61.—Wire line construction in communication trenches.

(2) Except in narrow fire trenches, wire lines should be kept ordinarily on the side of the trench nearest the enemy. Wire placed at heights between 10 and 30 inches from the duck boards or bottom of the trench is least subject to damage from cave-ins, water, and traffic.

(3) Field wire may be fastened to the side of a trench, as shown in the composite figure 61, by—

(a) Staples made of stiff wire and about 12 inches long. The staples are driven into the ground as far as possible, thus holding the wire closely against the side of the trench.

(b) Attaching the wire to insulators mounted on boards which are fastened to the sides of the trench by wire, stakes, rods, or staples.

(c) Attaching the wire to insulators nailed to the ends of wooden stakes or pegs which are driven into the trench wall.

(d) Attaching the wire to insulators nailed to posts which are driven into the bottom of the trench close to the side.

(e) Passing the wire through supports made of No. 9 or heavier GI wire. One end of the support wire is attached to a stake driven into the ground just outside the edge of the trench.

(f) Attaching the wire to revetment posts, either directly or on insulators.

■ 206. LOADING OF FIELD WIRE LINES.—*a. Purpose.*—Telephone transmission over long field wire circuits may be increased by the use of loading coils. If properly spaced as indicated in *c* below, their use will result in an improvement in transmission of about 30 percent over a nonloaded circuit of equal length. The transmission improvement is due to the fact that the inductance added to the line by the coils acts to neutralize to a certain extent the effect of the capacitance of the field wire which normally is a large factor in attenuating the voice transmission.

b. Description of coil C-114 (loading).—The coil C-114 is contained in a watertight aluminum alloy case and weighs about two pounds. The cover is hinged along one side and is held closed by a latch, a rubber gasket making a watertight seal. The line wires are connected by opening the cover and inserting the wires in the slots of the four binding posts. The head of each binding post contains a steel pin, so that when it is screwed down the pin is driven through the insulation and makes contact with the conductor. When the cover is closed, the line wires come out through grooves in the rubber gasket opposite the binding posts. (See fig. 62.)

c. Spacing.—The loading coils are designed to be installed at intervals of 1 mile in wire W-110 and W-110-B. The distance between one terminal of a circuit and the first coil, or the distance between the other terminal and the last coil, is known as an end section and should not be less than 0.2

mile nor greater than 1 mile. The coil spacing between end sections should not deviate more than plus or minus 5 percent from 1 mile. The coils are intended to improve circuits which would otherwise be unsatisfactory, and lines less than 10 miles in length are usually satisfactory without the use of the coils.

d. Installation.—The coil is installed in a circuit by connecting the field wire from one direction to the two adjacent binding posts marked L_1 and L_2 at one end of the coil, and

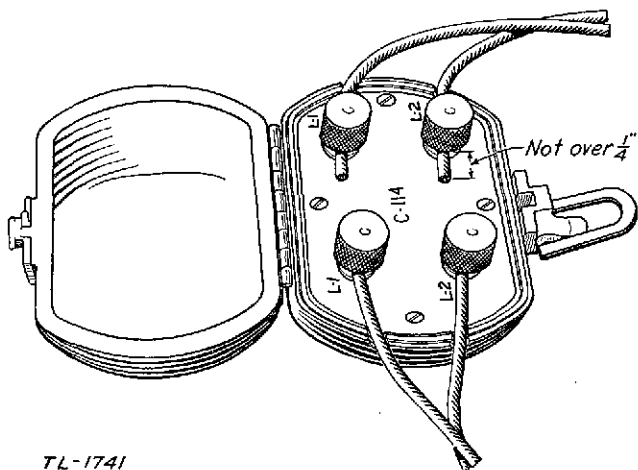

TL-1741

FIGURE 62.—Coil C-114 (loading).

the field wire from the other direction to the two remaining binding posts similarly marked. The wires should not be skinned when making connections to the terminals, nor should the inside ends of the wires extend more than $\frac{1}{4}$ inch from the terminals after connections are completed. When closing the cover it is necessary to make certain that all four wires fit snugly into the grooves in the rubber gasket. Loaded circuits should be terminated in the same manner that unloaded circuits would be terminated. All strain should be taken off the coil connections, however, in order to avoid damage to the coil and not to reduce the tensile strength of the line.

SECTION III

FIELD TELEPHONES AND CENTRALS

■ 207. **INSTALLATION OF TELEPHONES.**—Telephones for use on field wire systems are usually local battery (magneto) instruments. These instruments have common operating characteristics but vary in details of construction. When installing any telephone place it in a position convenient to the user. Tie the local circuit in near the instrument, leaving sufficient slack between the tie and the instrument to permit some movement of the telephone. If the circuit enters the place of installation from overhead, make a drip loop in it to drain water away from the instrument. (See fig. 32.) Attach to the telephone the telephone directory referred to in paragraph 177 and a tag bearing the directory name and number of that telephone. When the installation has been tested and is complete, inform the user that it is ready for use.

■ 208. **TYPES OF FIELD TELEPHONES.**—There are three types of telephones in common use on field wire systems—the EE-8, EE-4, and EE-5.

a. *Telephone EE-8.*—For the installation, operation, and maintenance of the telephone EE-8, see TR 1225-10.

b. *Telephone EE-4* (fig. 63).—(1) *Description and use.*—(a) The telephone EE-4 is contained in a wooden case with an adjustable carrying strap and weighs 18 pounds. It has a generator for ringing and a bell for being signaled. All elements except the handset are mounted in an aluminum alloy frame which is held in place by machine screws. When installed, the handset hangs from a hook switch outside of the case. When packed for transportation, the handset is placed inside the case in the space between the frame and the case. The hook switch lever also folds inside the case, and care must be taken to see that this is done whenever the telephone is packed for transportation, otherwise the battery will quickly run down. One battery BA-1 (3 volts) furnishes power for transmission and is inserted in a compartment in the frame.

(b) On the top of the frame is a bakelite panel on which are mounted two wing nut binding posts marked L_1 and L_2 for the line wires; two binding posts marked BATT for external battery if required (if an external battery is used, the internal battery BA-1 must be removed); and binding posts marked Y, R, and G, for the yellow (transmitter), red (common), and green (receiver) conductors, respectively, of the handset cord. A hook is provided for attaching the stay cord of the handset cord.

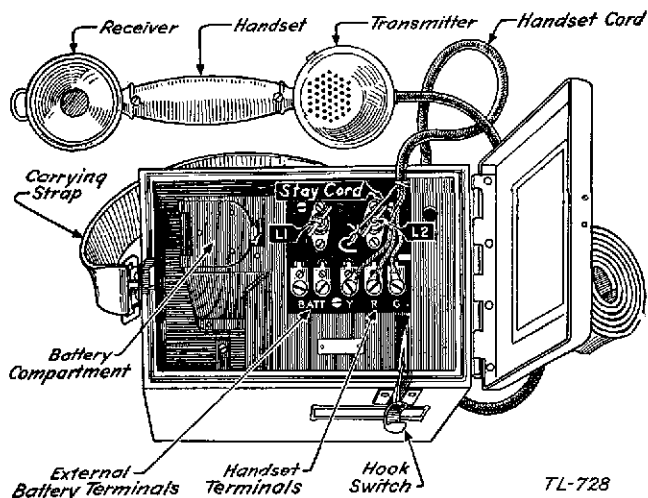

FIGURE 63.—Top view of telephone EE-4.

(c) The telephone EE-4 may be used on either local battery (magneto) or on common battery circuits. If used on a common battery circuit, however, see (3) (b) below.

(2) *Preliminary tests.*—(a) *Transmitting and receiving circuits.*—Place a serviceable battery BA-1 in the battery compartment. Short the binding posts L_1 and L_2 , hold the receiver to the ear, and blow steadily into the transmitter while moving the hook switch slowly up and down. The sound (sidetone) should be heard distinctly in the receiver when the hook switch is up, but should not be heard when

it is depressed. This indicates that the transmitting and receiving circuits are probably in good condition. If the sidetone is not heard or is weak when the hook switch is up, install a fresh battery and repeat the test. If the sidetone is still not heard, or if it is heard when the hook switch is depressed, the transmitting or the receiving circuit is in trouble. In that case, turn the telephone in for repair.

(b) *Signaling circuit.*

1. With the handset on the hook switch, turn the generator crank rapidly in a clockwise direction for several turns. It should turn easily and the bell should ring.
2. Short L_1 and L_2 and again turn the generator crank. It should turn hard as though a drag had been placed on it, and the bell should not ring.
3. The above tests indicate that the signaling circuit is probably in good condition. If either one of the tests fails, the signaling circuit is in trouble. In that case, turn the telephone in for repair.

(3) *Operation.*—(a) *On a local battery circuit.*—Connect the line wires to L_1 and L_2 , see that a serviceable battery BA-1 is in the battery compartment, and bring the hook of the hook switch lever out. Close the cover, bringing the line wires and handset cord out through the notch provided in the side of the box, and hang the handset on the hook switch.

1. *To signal.*—With the handset on the hook switch, or with the hook switch held down, turn the generator crank rapidly for several turns.
2. *To talk and listen.*—Remove the handset from the hook switch, hold the receiver to the ear so that the transmitter is about 1 inch from the lips, and talk directly into the transmitter. The transmitting and receiving circuits are both closed and ready for operation as long as the hook switch is up.
3. *To ring off.*—When the conversation is completed, hang the handset on the hook switch and ring

off by two or three sharp turns on the generator crank. This operation is necessary only when the telephone is connected to a switchboard. It operates a signal at the switchboard which indicates to the operator that the conversation is finished, or that another connection is desired.

(b) *On a common battery circuit.*—When this telephone is used on a common battery circuit, direct current flows through the receiver all of the time that the telephone is in use. If the direction of flow of this current is such as to tend to neutralize the field of the permanent magnets of the receiver, the receiver will not function efficiently and the magnets will in time lose their magnetism. To avoid this, connect the line wires to L_1 and L_2 , bring the hook of the hook switch out but keep the handset off the hook. Unscrew the receiver cap, place the edge of the diaphragm against the receiver pole pieces, and note the pull of the magnets on the diaphragm. Reverse the line wire connections and repeat. Connect the line wires to the telephone permanently so as to give the greater pull. Do not remove the battery BA-1 because it is necessary to furnish talking current. Hang the handset on the hook switch.

1. *To signal the operator.*—Remove the handset from the hook switch and wait for the operator to answer. The operator may be flashed or recalled by moving the hook switch slowly down and up.

2. *To talk and listen.*—Proceed as for local battery operation. When the conversation is completed, replace the handset on the hook switch. It is not necessary to ring off.

c. Telephone EE-5 (fig. 64).—(1) *Description and use.*—

(a) The telephone EE-5 is contained in a leather case with an adjustable carrying strap and weighs 11 pounds. It has a generator for ringing and a buzzer for being signaled. All elements except the handset are mounted in an aluminum alloy frame which is held in place in the case by machine screws. When not in use, the handset occupies the remaining space inside of the case. One battery BA-9 ($4\frac{1}{2}$ volts)

furnishes power for transmission, and is inserted in a spring clip just below the top of the frame. The battery is covered by the leather flap formed by one side of the case. Two screws which hold this flap to the frame must be removed to insert the battery, after which the screws should be replaced.

(b) The top of the frame is a hard wood panel on which are two knurled screw driver binding posts marked L and

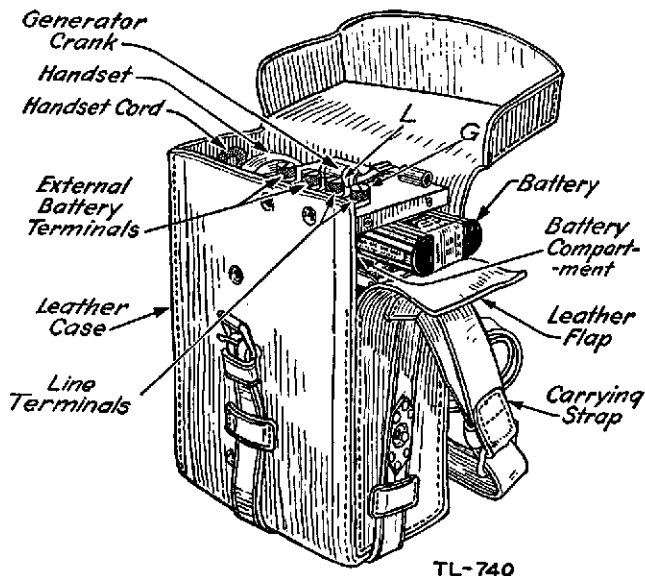

FIGURE 64.—Telephone EE-5.

G for the line wires, and two similar binding posts for external battery if required (if an external battery is used, the internal battery BA-9 must be removed). A clip on the panel holds the generator crank when the telephone is packed for transportation. To use the generator, remove the crank from the clip and screw it on to the generator shaft at the side of the case. Cranks carelessly mislaid or lost reduce the utility of the instrument for calling purposes.

The handset cord is connected to terminals inside the frame. The handset is provided with a push button switch which must be depressed in order to talk. The receiving circuit is always in operation, regardless of the position of the push button.

(c) The telephone EE-5 is intended for use on local battery (magneto) circuits only, and cannot be used on common battery circuits.

(2) *Preliminary tests.*—(a) *Transmitting and receiving circuits.*—Place a serviceable battery BA-9 in the clip under the panel, bending the battery terminals if necessary to insure good contact with the battery springs inside the frame. Terminals of new batteries have a coating of paraffin which must be scraped off before inserting to insure good contact. Short the line binding posts L and G, being sure that the contacts are made on the binding posts themselves because good contacts are difficult to secure on the thumb nuts. Hold the receiver to the ear and blow steadily into the transmitter while alternately depressing and releasing the push button slowly. The sound (sidetone) should be heard distinctly in the receiver when the push button is depressed, but should not be heard when it is released. This indicates that the transmitting and receiving circuits are probably in good condition. If the sidetone is not heard or is weak when the push button is depressed, install a fresh battery and repeat the test. If the sidetone is still not heard, or if it is heard when the push button is released, either the transmitting or the receiving circuit is in trouble. In that case, turn the telephone in for repair.

(b) *Signaling circuit.*

1. Turn the generator crank rapidly in a clockwise direction for several turns. It should turn easily, but the buzzer should not operate.
2. Short the line binding posts L and G and again turn the generator crank. It should turn hard as though a drag had been placed on it and the buzzer should not operate.
3. Connect the telephone to another telephone that is known to be serviceable. Turn the generator

crank of the test telephone. The buzzer of the telephone under test should operate.

4. The above tests indicate that the signaling circuit is probably in good condition. If any one of the tests fails, the signaling circuit is in trouble and the telephone should be turned in for repair.

(3) *Operation.*—To operate the telephone EE-5, connect the line wires to L and G and see that a serviceable battery BA-9 is in the clip under the terminal panel.

(a) *To signal.*—Turn the generator crank rapidly for several turns, holding the instrument firmly.

(b) *To talk and listen.*—Hold the handset with the receiver to the ear and the transmitter about 1 inch from the lips, depress the push button on the handset with the thumb, and talk directly into the transmitter. While listening only, release the push button to conserve battery, as its depression is not necessary for listening.

(c) *To ring off.*—When the conversation is completed, ring off by two or three sharp turns on the generator crank. This operation is necessary only when the telephone is connected to a switchboard. It operates a signal at the switchboard which indicates to the operator that the conversation is finished or that another connection is desired.

■ 209. INSTALLATION OF TELEPHONE CENTRALS.—*a.* Installation of a field telephone central includes installing the switchboard and its auxiliary equipment, terminal strips if required, and testing equipment if available. It also includes the installation of local circuits and telephones (except long locals), and making the proper connections at the switchboard terminal strip of these circuits and the trunk circuits turned over by construction details.

b. Each circuit is tested as soon as it is connected, and when it is in satisfactory operative condition the time is recorded and the message center is informed of the available service. A traffic diagram is prepared and posted together with a copy of the telephone directory for the use of the operator.

c. The use of circuits is not delayed pending the installation of the switchboard. If trunk circuits are available before

they can be connected to the switchboard, they are connected directly to telephones to give temporary service until the switchboard is installed.

d. After the telephone central is installed and operating, circuits should be rearranged for their better protection, to improve the appearance of the installation, and to facilitate maintenance. Care is taken that circuits radiating from a telephone central are not subject to interference from troops and traffic in the vicinity of the command post. They are placed overhead, underground, or otherwise protected.

e. Priority in which local telephones are installed at a command post varies with the situation and the orders of the commander. They are normally installed in the following order:

Message center.

Commander (or chief of staff or executive).

Operations section (G-3 or S-3).

Intelligence section (G-2 or S-2).

Supply section (G-4 or S-4).

Signal section (signal officer).

Personnel section (G-1 or S-1).

Public telephone, for personnel not furnished individual telephones.

Other staff officers and activities as required.

f. At command posts of small units, as in battalions, or regiments, one telephone ordinarily serves two or more staff officers. At larger headquarters, more than one telephone may be required in each staff section. At rear echelons telephones are reduced to minimum requirements.

g. Switching centrals are installed in the same manner as telephone centrals except that normally only such local circuits and telephones as are specifically ordered are installed.

■ 210. INSTALLATION OF TELEPHONE SWITCHBOARDS.—A field telephone central may include one or more switchboards, depending on the number of trunk and local circuits to be installed and the amount of traffic to be handled. With certain types of switchboards it is necessary to install terminal strips; with others the terminal strips, repeating coils, etc., are included as parts of the switchboard itself, and addi-

tional terminal equipment is not required. The switchboard and its associated equipment are installed in a centrally located place affording as much shelter and freedom from noise or interference as possible.

■ 211. REPEATING COILS.—Repeating coils are used in field wire systems for the construction of simplex and phantom circuits. Additional telegraph or telephone channels may be secured by their use.

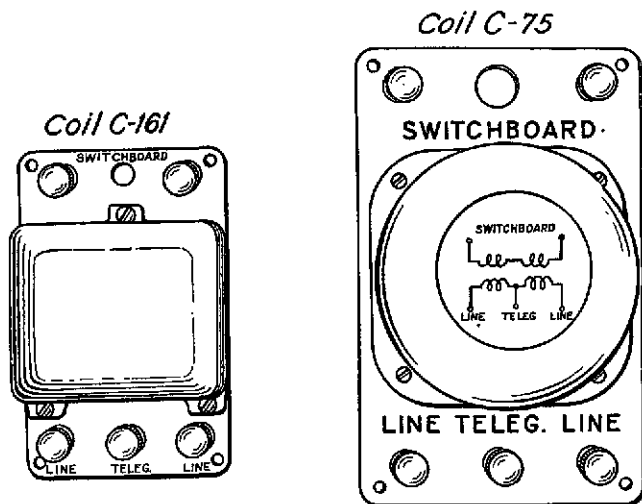

TL-1743

FIGURE 65.—Coils C-161 and C-75 (repeating).

a. Military types.—The coils commonly issued for use in the field are the coil C-75 and the coil C-161 (fig. 65). The coil C-161 is also an integral part of certain switchboards. The repeating coil consists of two windings on a magnetic core. The ends of one winding are brought out to two terminals marked **LINE** which are to be connected to the line. The ends of the other winding are brought out to two terminals marked **SWITCHBOARD** which are to be connected to the switchboard line circuit. The midpoint of the line side of the coil is brought out to a fifth terminal marked

TELEG, which can be connected to provide a simplex or a phantom circuit as explained in paragraphs 212 and 213. The windings have been carefully balanced to prevent cross-talk. The coil C-75 is similar in electrical characteristics to the coil C-161, but the latter is more efficient, smaller, and lighter.

b. Commercial type.—Repeating coils issued may be of commercial design. In this type of coil, the ends of the

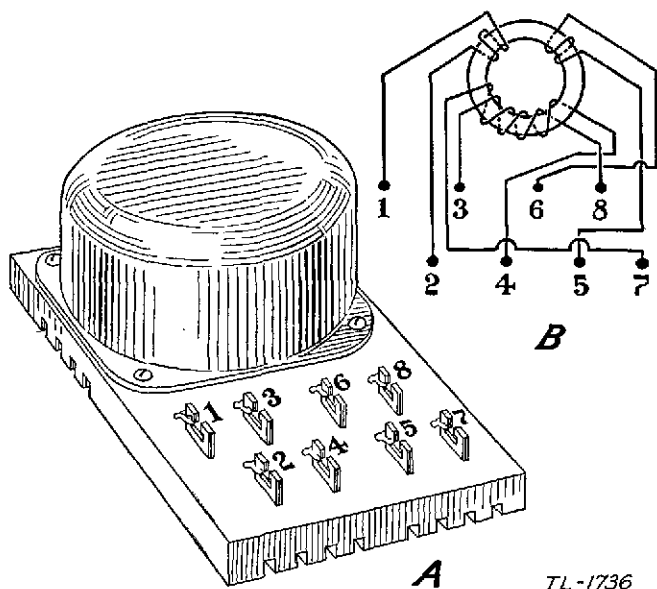
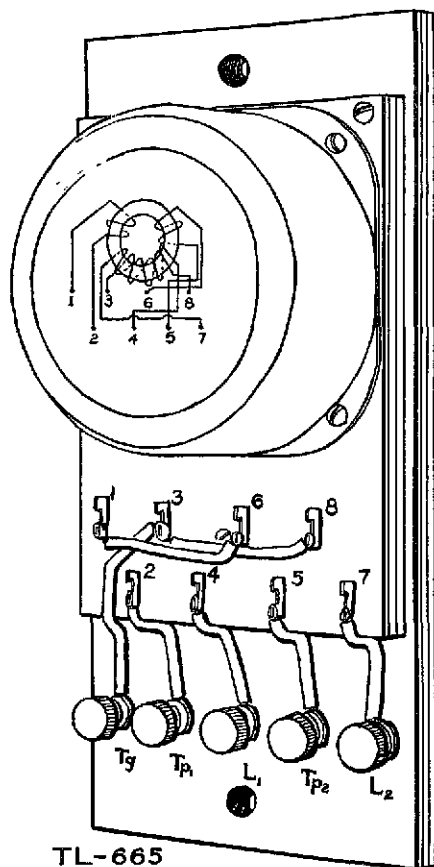

FIGURE 66.—Commercial type repeating coil.

windings are brought out to terminals numbered 1 to 8 as shown in figure 66. Prior to being taken into the field, repeating coils of commercial type are prepared for installation as shown in figure 67. Terminals 1 and 6 are connected together and terminals 3 and 8 are connected together. Terminals 4 and 7 are connected, respectively, to binding posts marked L_1 and L_2 . Terminals 2 and 5 are connected, respectively, to binding posts marked Tp_1 and Tp_2 . Termi-

nals 3 and 8 together are connected to a binding post marked Tg. All connections must be soldered and all wires must be protected from mechanical injury. The binding posts are



TL-665

FIGURE 67.—Commercial type repeating coil adapted for field use. screwed to a thin piece of wood on which the repeating coil is mounted. Commercial repeating coils thus prepared may be employed in the same manner as described in *a* above

for coils C-75 and C-161, the terminals marked L_1 and L_2 being used as the LINE terminals, the terminals Tp_1 and Tp_2 as the SWITCHBOARD terminals, and the Tg terminal as the TELEG terminal.

■ 212. SIMPLEX CIRCUIT (fig. 68).—*a.* The simplex circuit is obtained by placing a repeating coil at each end of a metallic circuit (par. 164). The coil at each end is usually located in the line as close to the switchboard terminal strip as practicable. The binding posts marked LINE or L_1 and L_2 are connected directly to the line, and those marked SWITCHBOARD or Tp_1 and Tp_2 are connected to the desired line circuit on the switchboard terminal strip. The telephone circuit on the switchboard terminal strip. The telephone circuit is completed inductively through the coil. The bind-

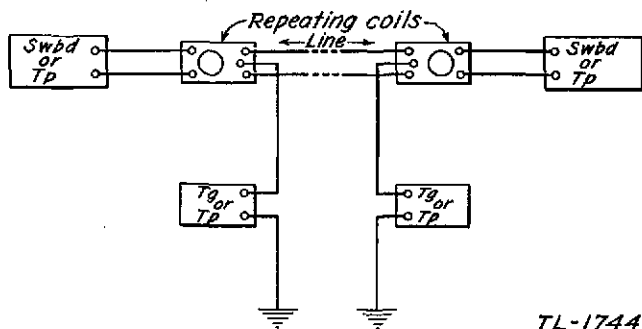

FIGURE 68.—Simplex circuit constructed with repeating coils.

ing post marked TELEG or Tg is connected to the line leading to one line terminal of the telegraph instrument, the other line terminal of which is ordinarily grounded near the instrument. This line to the telegraph instrument is usually referred to as the telegraph leg.

b. When only a telephone, without a switchboard, is installed, the repeating coil is inserted between the telephone and the line.

c. In a switchboard which is equipped with repeating coils and a terminal strip as parts of the switchboard itself, the repeating coils are already properly connected between the terminal strip and certain switchboard units. It is simply

necessary therefore to connect the desired line to the proper binding posts on the terminal strip, and to run the telegraph leg from the corresponding telegraph binding post provided thereon to the telegraph set.

■ 213. PHANTOM CIRCUIT.—*a.* A phantom circuit may be constructed from two metallic circuits, both of which have repeating coils at each end. The coils are usually located near the switchboard terminal strip, except where they are integral parts of the switchboard. A coil is connected in each circuit at each end as for the simplex circuit described in paragraph 212. However, instead of connecting the **TELEG** terminals of the coils to telegraph instruments, the

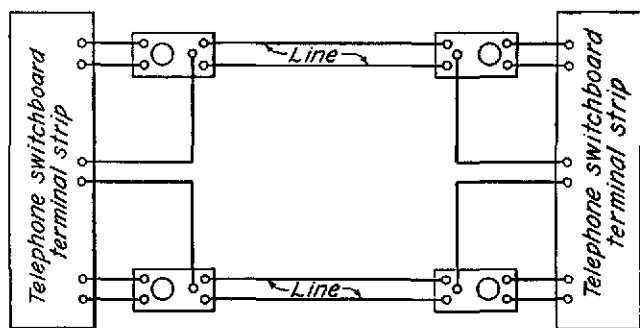

TL-1745

FIGURE 69.—Phantom circuit constructed with repeating coils.

two terminals marked **TELEG** at each end are connected to the desired line circuit on the switchboard terminal strip, thus forming the phantom circuit. (See fig. 69.)

b. If desired, the phantom circuit thus formed may be simplexed to obtain a telegraph circuit in the same manner as described above for a single metallic circuit. This requires the use of an additional repeating coil at each end. (See fig. 70.)

c. In switchboards which are already equipped with repeating coils and terminal strips, a phantom circuit can be obtained by simply connecting the two physical circuits to the proper terminals on the terminal strip of each switchboard,

and connecting the corresponding telegraph binding posts to the desired line circuit on the terminal strip, thus forming the phantom circuit.

■ 214. MUTUAL INTERFERENCE IN SIMPLEX AND PHANTOM GROUPS.—*a.* In these types of construction, mutual interference between simultaneous signals passing over the different channels in one group will result only when each wire in the simplex or phantom group does not have exactly the same impedance. When such is the case, the circuits are said to be unbalanced and the amount of the interference will depend upon the degree of unbalance existing in or between

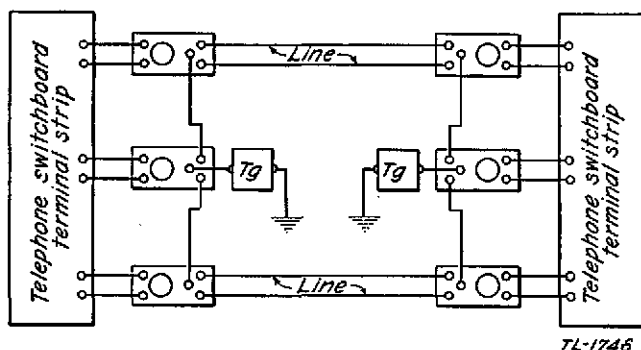

FIGURE 70.—Simplex phantom circuit.

the physical, or metallic, circuits. The primary causes of unbalance in field wire circuits are poor splices which may introduce a high resistance into either side of the circuit or improperly taped splices or damaged insulation which, particularly when wet, may result in excessive leakage from one side of the circuit to ground. It is impossible to obtain a perfect impedance balance in field wire circuits. However, mutual interference may be reduced to a negligible value by making sure that each wire of a group is of approximately the same length, that all splices are well made, and by employing overhead construction at low, wet places and during rainy weather. Resistance unbalance may be improved by inserting a variable resistance in the low resistance side of

an unbalanced circuit. The low resistance side is determined by trial first with the variable resistance in one side of the circuit and then in the other. After determining the low resistance side and inserting the variable resistance in that side of the circuit, the resistance is varied until the interference is reduced to a minimum.

b. The interference resulting from any unbalance is usually more pronounced in a phantom group than in a simplex group as there are more circuits involved. Also, mutual interference between two telephone channels is much more serious, due to their similarity of sound, than is the interference of telegraph in the telephone circuit on which it is superimposed where the interference appears as key clicks in the telephone receiver. For these reasons, a simplex circuit to provide an additional ground return telephone channel and phantom circuits are not generally used in field wire systems.

■ 215. TYPES OF FIELD SWITCHBOARDS.—There are five types of switchboards in common use on field wire systems: switchboards BD-14, BD-71, BD-72, BD-9, and BD-11. All except the first named are monocord switchboards.

a. *BD-14*.—For the installation, operation, and maintenance of switchboard BD-14, see TR 1225-5.

b. *BD-71 and BD-72*.—For the installation, operation, and maintenance of switchboards BD-71 and BD-72, see TR 1225-1.

c. *BD-9 and BD-11*.—(1) *Description*.—Switchboards BD-9 and BD-11 are portable magneto monocord switchboards for use primarily in the wire systems of units of the infantry division. They will eventually be replaced by switchboards BD-71 and BD-72. The capacity of the BD-9 is 4 lines and that of the BD-11 is 12 lines. In other respects the switchboards are identical. A fiber carrying case with carrying strap is provided for protection of the switchboard in transportation. No terminal strips, repeating coils, or operator's telephone set are included in the switchboard. Therefore, these items must be installed in addition. Any of the telephones EE-3, EE-4, or EE-5 may be used as the operator's telephone. Repeating coils, if required, are in-

stalled as described in paragraphs 212 and 213. Each switchboard should be equipped with a switchboard cable and terminal strip as explained in (2) below prior to taking it into the field. These remain integral parts of the switchboard and should not be disconnected except for replacement.

(2) *Preparing cable.*—(a) To prepare cable for these switchboards cut wire W-110 (or similar twisted pair field wire) into 11-foot lengths, cutting one more length than there are units on the switchboard.

(b) Stand facing the switchboard, connect one pair of wires to the line terminals of the left-hand switchboard unit, and temporarily attach the other end of the pair to the upper left-hand pair of binding posts on a terminal strip placed about 10 feet from the switchboard. To connect to the line terminals of the switchboard unit, skin off only enough insulation from the end of each wire so that the insulation will touch the binding post when the wire is fully inserted in the binding post. Connect the remaining lengths of wire similarly in order from left to right on the switchboard and from top to bottom on the terminal strip. Leave the extra pair sufficiently long so that each free end will reach any pair of binding posts; this is a spare pair for use in case one of the others becomes unserviceable.

(c) Lace the wires together neatly and securely with a piece of lacing twine or other stout cord. Begin at the switchboard and use a lockstitch (fig. 71). Do not lace the cable so tightly that the insulation on the wires is bruised. Each pair of wires should leave the cable together as a pair rather than as individual wires. If the wires run parallel to each other throughout the cable and are tightly squeezed together, crosstalk may be caused between the circuits, especially in wet weather. Work toward the terminal strip in lacing, spacing the stitches about $1\frac{1}{2}$ inches apart, pushing the slack in the wires ahead of the lacing so as to make a neat and compact cable. At the terminal strip, the wires of each pair should come out as a pair opposite the proper left-hand binding posts on the terminal strip. Form the wires along the side of the terminal strip and cut them so that each will be of the proper length for attaching to its proper binding post, and then attach them in the same

order as before. Leave the ends of the spare pair free until the cable is completed, then lace them down with a separate piece of twine so that when needed it will not be necessary to cut the main lacing of the cable.

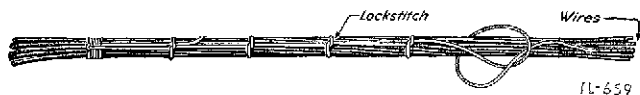

FIGURE 71.—Lock stitch.

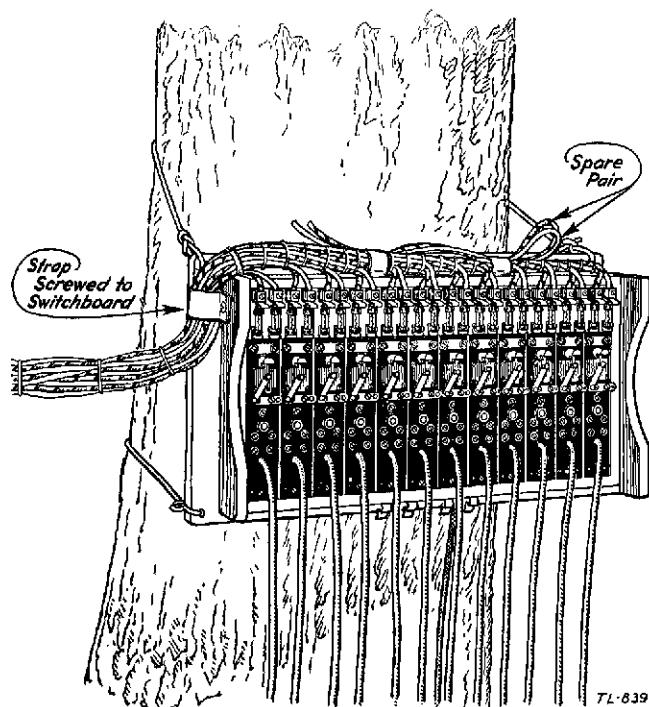

FIGURE 72.—Cable secured to monocord switchboard.

(d) Route the cable down one side of the switchboard and secure the cable to it in order to relieve the terminal connections of all strain. Secure the cable to the wooden part

of the switchboard by clamping it with strips of leather held down with brass screws (fig. 72). Mount the terminal strips on a wood strip and secure the cable to the wood to relieve the terminal strip binding post connections of strain. Coil the cable during transportation for protection.

(3) *Installation* (figs. 73 and 74).—(a) The switchboard, with cable and switchboard terminal strip attached, is installed in the following manner:

1. Secure the switchboard to a support. Holes in the wooden back permit the tying of the switchboard to the support with a piece of wire or stout cord. Do not drive nails through any part of the frame. The cords should hang free without the plugs touching the ground. The switchboard should be vertical or tilt slightly forward to permit the shutters to fall when released.
2. Install the switchboard terminal strip. In some cases a single tree may suffice for mounting both the switchboard and the terminal strip, the switchboard being placed on one side and the terminal strip on the other. The terminal strip should be out of the way of the operator, but conveniently placed for maintenance personnel to work thereat. Route the cable from the switchboard to the terminal strip so as to afford maximum protection against injury.
3. Connect the operator's telephone to the spring clip terminals on the switchboard marked L_1 and L_2 . Connect a low resistance buzzer or bell as a night alarm across the terminals marked A and A_1 , and a dry battery for operating the night alarm across terminals marked B and B_1 . Connect a wire from the terminal marked G to a suitable metal ground rod or stake driven in the ground near the switchboard (par. 228). Release the shutters of the units which are to be used by lowering the spring locking bars to the horizontal position.

4. Write with a lead pencil (not ink or indelible pencil) the designation of the circuits or directory numbers on the small celluloid strips on each switch-board unit.

(b) The arrangement of equipment as shown in the illustrations is not mandatory, but for illustrative purposes only. The equipment should be so arranged that it can be most effectively operated under existing conditions.

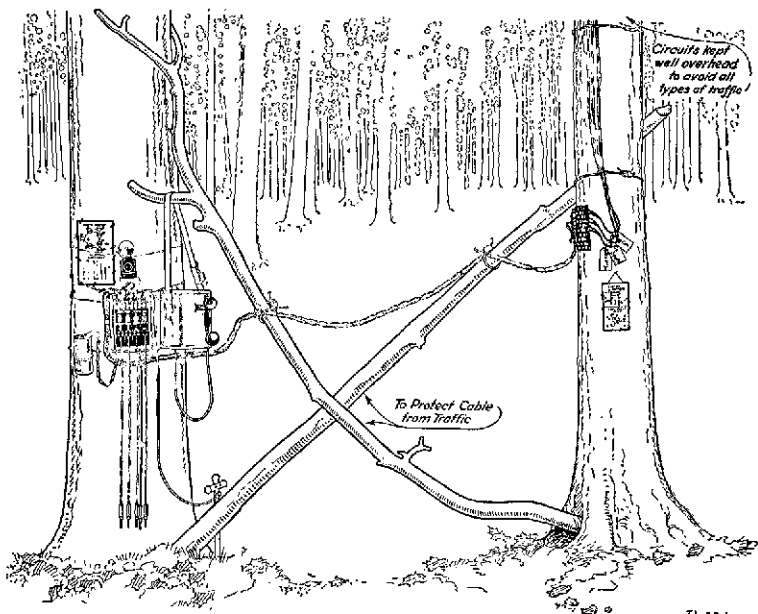

FIGURE 73.—Telephone central using monocord switchboard.

- (4) *Preliminary tests.*—(a) *Operator's cord circuit.*
1. Turn the generator crank of the operator's telephone rapidly for several turns. It should turn easily.
 2. Short circuit the tip and sleeve of the operator's plug and again turn the generator crank. It should turn hard.

(b) *Switchboard units.*

1. See that two serviceable fuses are installed in the spring clips at the top of each switchboard unit. Hold the operator's plug between the line terminal binding posts of the first unit so that the

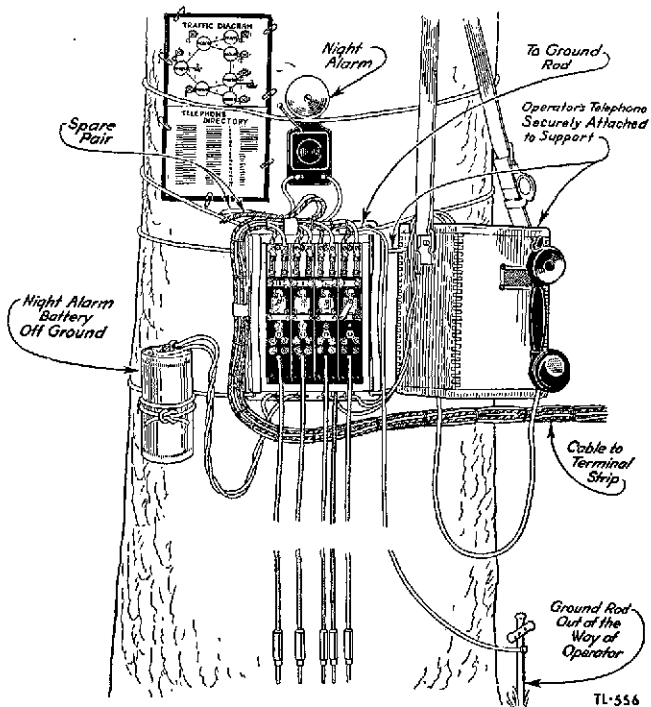

FIGURE 74.—Installation of monocord switchboard.

tip makes contact with one binding post and the sleeve with the other. Turn the generator crank of the telephone. The shutter of the unit should fall and the night alarm bell or buzzer should operate. Restoring the shutter should stop the alarm.

2. Insert the operator's plug in the jack of the first unit and turn the generator crank. It should turn easily. Short the line terminals of the unit and again turn the generator crank. It should turn hard, but the shutter should not fall in either case.
3. Remove the short from the line terminals of the unit. Short the tip and sleeve of the plug of the unit and turn the generator crank. It should turn hard and the drop should not fall.
4. Test each unit in the same manner as above. If any one of the above tests fails, turn the switchboard in for repair, or replace the faulty unit.

(5) *Installation in parallel.*—(a) Circumstances may arise where one monocord switchboard is insufficient for the number of circuits. In this case two or more monocord switchboards may be connected in parallel. Usually only two will be necessary, as organizations requiring more will be equipped with switchboards of a type having a greater number of drops. The number capable of being installed in parallel, except as in (b) below, is limited by the length of the cords, which must be sufficiently long to reach any jack in the group. Installation is made as follows:

1. Install the first switchboard as prescribed in (3) above, leaving sufficient space between the switchboard and operator's telephone to place the desired number of additional switchboards.
2. Install additional switchboards to the right-hand side of the first. Installation is the same, except that only certain terminals are connected and these are connected in parallel to the corresponding terminals on the first switchboard (fig. 75); to ground the switchboard, connect terminals G to G; to make use of the night alarm, connect terminals A₁ to A₁ and B₁ to B₁; when the operator's cord on the first switchboard is not sufficiently long to reach all units on the additional switchboards connect terminals L₁ to L₁ and L₂ to L₂.

(b) When the switchboards connected in parallel are installed in a manner which prohibits the plugging in of any unit cord in all of the other unit jacks, full use may be made of the switchboards by trunking the switchboards together. This is accomplished by reserving for trunking one or more units on the right-hand side of the left-hand switchboard and a like number of units on the left-hand side of the right-hand switchboard. Plug the cord of the unit of the left-hand switchboard into the jack of the unit of the right-hand switchboard and leave this connection up throughout

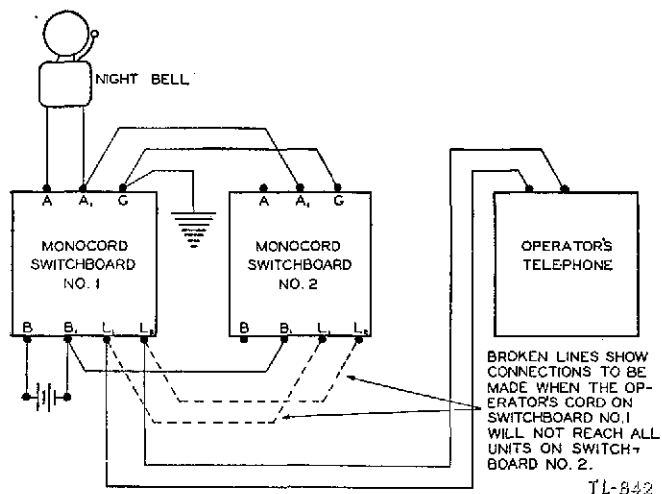

FIGURE 75.—Parallel connection of monocord switchboards.

the operation of the switchboards in parallel. Any connection to be made between the switchboards where the unit cords will not reach may be made through these two units which are trunked together.

(6) *Operation.*—(a) An incoming call is indicated by the falling of the shutter of the calling line. Insert the operator's plug into the calling party's jack. After determining the party (or central) to be called, remove the operator's plug and insert it in the called party's jack. Ring the called

party by turning the generator crank of the operator's telephone and then insert the called party's plug into the calling party's jack. In the case of a trunk call, do not insert the called party's plug in the calling party's jack until after the number has been passed to the distant operator. The operator's plug may be left in the called party's jack until the conversation has actually begun or until it is necessary to answer another call. When the conversation has actually begun, remove the operator's plug and restore the shutter. In case it is necessary to answer another call before the first connection has been properly supervised do not restore the shutter until the first connection has been supervised.

(b) When the conversation is completed and either party rings off, the called party's shutter will fall. Insert the operator's plug into the called party's jack and answer the signal to see if either party desires another connection. If no reply is received, take the connection down and restore the shutter.

(c) The operation of two switchboards in parallel is the same as the operation of a single switchboard, one operator's set being used for both switchboards ((5) above).

(d) When two parties desire a straight-through connection so that either party can ring the other without operating the shutters or requiring the services of the operator, the units may be cross-patched, that is, the plug of one unit inserted in the jack of the other unit and vice versa. Such connections are not established except as directed by the signal or communication officer. This action disconnects both drops from the circuit and provides a direct connection between the two lines. Since neither party is then able to signal the operator, the latter should be informed as to how long the through connection is desired.

■ 216. CONFERENCE CALLS ON SWITCHBOARDS BD-9 AND BD-11.—A calling party desiring a simultaneous connection with two or more called parties states "Conference call" and gives the directory names and numbers of the parties desired. In that case, proceed as follows:

a. Inform the calling party that he will be called when all parties are on the line.

b. Ring the first of the called parties and when he answers request him to hold the line for a conference call, telling him what party is calling.

c. Ring the second called party and when he answers request him also to hold the line for a conference call. Then plug the first called party's plug into the second called party's jack. Extend the connection in a similar manner to each of the called parties in turn.

d. When the last of the called parties has been connected, ring the calling party, if he is not already on the line. Inform the calling party that all parties are now on the line, then plug the calling party's plug into the first called party's jack, and tell the calling party to go ahead.

e. When the conversation has begun, remove the operator's plug from the calling party's jack and restore his shutter. All parties are now connected and each can talk or listen to any of the others. The calling party's drop remains bridged across the connection for a supervisory signal. The connection may be supervised by plugging into the calling party's jack.

■ 217. URGENT CALLS.—Upon informing a calling party that a certain circuit or party is busy, or in other cases, an operator may be told by the calling party that the call is an urgent call. In this case, proceed as follows:

a. If all trunk circuits leading to the distant central are busy, select one circuit and inform the parties using it that it is desired for an urgent call, indicating the directory name and number of the individual requiring the circuit and requesting the parties to release it by hanging up.

b. Ring the distant operator and request connection with the called party in the usual manner.

c. The distant operator then clears the called party's line as described in *a* above and completes the urgent connection.

d. Remain on the circuit and supervise the connection until it is established.

■ 218. CARE OF FIELD TELEPHONE EQUIPMENT.—When equipment containing batteries is removed from service for any reason, remove the batteries from the equipment. If this

is not done, corrosion will take place at the battery contacts and the wiring will eventually become damaged. Do not allow dirt to accumulate on any part of the equipment. Keep terminals and contacts particularly clean. Dirt in the air gaps of lightning arresters is a frequent source of trouble. Keep all mounting screws and wire connections tight. Protect the equipment from the elements as far as practicable when installed, and place it in a cool, dry place when stored. Do not attempt field repairs beyond the replacement of batteries, the replacement of broken or defective elements or parts which can be properly replaced with tools issued, and the checking and repair of loose or broken connections.

■ 219. SWITCHBOARD OPERATOR.—The ideal switchboard operator is courteous, intelligent, efficient, and capable of working for prolonged periods under stress. He should be familiar with Army organization, should be able to speak distinctly, and should be able to understand speech over the telephone readily. He should be selected with these qualifications in mind. He can be of great assistance to the wire chief by keeping him informed of the condition of the circuits.

■ 220. OPERATING PHRASES.—The following phrases are prescribed for use by switchboard operators in all cases where they apply, to the exclusion of other phrases of similar meaning:

a. "Magic". Used by the operator at the switchboard of the unit whose directory name is Magic in answering a call.

b. "Thank you". Used by an operator to indicate that he has correctly understood a number given to him by either a local party or by an operator of another central, and that he is proceeding to complete the call.

c. "What number please?" Used by an operator to request repetition of a number which he has not understood.

d. "The line is busy". Used by an operator to report that a local telephone for which he has received a call is already in use.

e. "Maytime is busy". Used by an operator who has received a call to be completed to a certain central (Maytime) to report that all trunks to that central are in use.

f. "Magic one-one does not answer". Used by an operator in reporting that a called party (Magic one-one) does not answer.

g. "Maytime does not answer". Used by an operator in reporting that a certain called central (Maytime) does not answer.

h. "Here's your party". Used by an operator whenever it is necessary for him to start the conversation over a connection.

i. "Waiting?" Used by an operator in supervising a connection, when no conversation is heard.

j. "I will ring again". Used by an operator when, in supervising a connection, he is informed that the called party did not answer.

k. "What number is calling, please?" Used by an operator if after supervising a connection he is given a new number to call by one of the parties.

l. "Magic three-zero has no telephone but I can give you Magic one-one". Used by an operator when there is no telephone at the number called, but another telephone is available to which the calling party might desire to be connected instead.

m. "What number were you calling, please?" Used by an operator to determine the number desired by a party who reports he has been given a wrong number or has been cut off.

n. "One moment please" or "I have a call for you". Used by an operator, if necessary, to hold either party on the line while a connection is being completed.

o. "Hello Magic", or "Hello Magic one-one". Used by an operator when there is confusion or interruption in getting an operator or called party on the line.

p. "I must interrupt—urgent call from Magic six—please hang up". Used by an operator to inform the parties using a circuit that it is required for an urgent call by a certain calling party.

■ 221. SUPERVISION.—*a.* A switchboard operator supervises each connection to insure that conversation is established between the calling party and the called party, and to remove the connection as soon as possible after the conversation is completed. The operator listens in after he has made a connection and rung the called party, waiting to hear the called party answer and conversation begin. In the case of a trunk call to another central, he remains in on the connection until the other central has answered and he has passed the call to the other central. In case it is necessary to answer another call before he has supervised a connection he goes back to it and does so at the first opportunity. A shutter is never restored on a connection until it has been supervised.

b. In supervising a connection which has already been established, the operator goes in on the connection and listens carefully. If no conversation is heard he challenges by asking "Waiting?" Great care is taken not to interrupt a conversation in progress. If he receives no response, he takes down the connection. If he is notified that the called party has not answered, he answers, "I will ring again", and does so. If he is informed that the connection is still in use, he removes the operator's plug. Connections are supervised frequently in the above manner in case both parties may have failed to ring off when the conversation was completed.

c. Normally, when a conversation is completed, the shutter on the connection will fall due to one of the parties ringing off. This is the signal for the operator to supervise the connection in the same manner as in *b* above. If a new number is given him by either party he asks "What number is calling?" and proceeds to complete the call in the usual manner.

■ 222. TRAFFIC DIAGRAM.—*a.* A traffic diagram is a chart showing the number of telephone channels actually existing between the centrals in a telephone system. Circuits connecting to distant locals are also shown. A single line indicates direct telephone communication; a numeral placed on the line indicates the number of channels available including phantom circuits. The units to which each telephone

central or distant local pertain are indicated by the telephone directory name and symbol of the unit.

b. The traffic diagram is prepared at each switchboard by the wire chief or chief operator, assisted by the operator on duty. It is prepared from information received over the wire system and shows such circuits only as are available for traffic. Its purpose is to indicate to the operator the most direct routing for a call to any other central in the system and to show alternate routings in case the direct routing is busy or out of order. For this purpose it often includes connecting telephone systems of other higher, lower, and adjacent units. It must be corrected continuously as changes occur and expanded as information is obtained. An example of a traffic diagram is shown on page 262.

■ 223. RECORDS.—At each telephone central such records covering its operation are kept as required by the signal or communication officer. These records may include a station log and a test and trouble record (par. 235).

■ 224. STATION LOG.—The station log is kept by the switchboard operator on duty under the supervision of the chief operator. A simple form for a station log contains the following information:

Station to which it applies.

Place, date, and hour station opened.

Place, date, and hour station closed.

Schedule of operators.

Time of connecting or removing circuits.

Interruptions to circuits (duration and nature).

STATION LOG

STATION: _____

OPENED			CLOSED			
PLACE	DATE	HOUR	PLACE	DATE	HOUR	
SCHEDULE OF OPERATORS						
CIRCUIT NO.	TIME CONNECTED	TIME REMOVED	INTERRUPTIONS OF SERVICE		NATURE OF TROUBLE	REMARKS
			FROM-	TO-		

SIGNATURE OF CHIEF OPERATOR

TL-673

■ 225. REPORTS TO MESSAGE CENTER.—The operating personnel keeps the message center continuously informed of telephone communication available to other centrals in the system. Interruptions and changes are similarly reported promptly to the message center.

SECTION IV

FIELD TELEGRAPH SETS AND STATIONS

■ 226. EMPLOYMENT.—*a.* The value of the telegraph in a field wire system must never be overlooked. A failure to utilize telegraph channels will seriously overburden any field telephone system that may be installed during the normal time allowable and will defeat the principal purpose of the telephone. At least one simplex telegraph circuit will be installed on every wire line provided the units being served by the wire have the equipment necessary (par. 161 *p*).

b. The telegraph printer is a telegraph typewriter designed for interchanging printed messages between two or more stations. It is employed between higher headquarters in the same manner as the telegraph is employed between headquarters of units within a division. Data relative to the employment of the telegraph printer will be found in the Signal Corps Field Manual.

■ 227. CIRCUITS.—Telegraph circuits used in field wire systems are usually obtained by simplexing existing telephone circuits, using repeating coils (par. 212). The telegraph terminal on the repeating coil or switchboard at each end of the circuit is connected to one line binding post of the telegraph instrument. This is the telegraph leg and may be either a single conductor or a twisted pair field wire with both conductors in parallel. The other line binding post of the telegraph set at a terminal station is connected to a suitable ground rod or other ground connection. For connections at way stations, see paragraph 230. In cases where a good ground connection cannot be obtained (par. 228), and a second telephone circuit can be simplexed, the other line binding post of the telegraph set at a terminal station, instead of being connected to ground, is connected to the

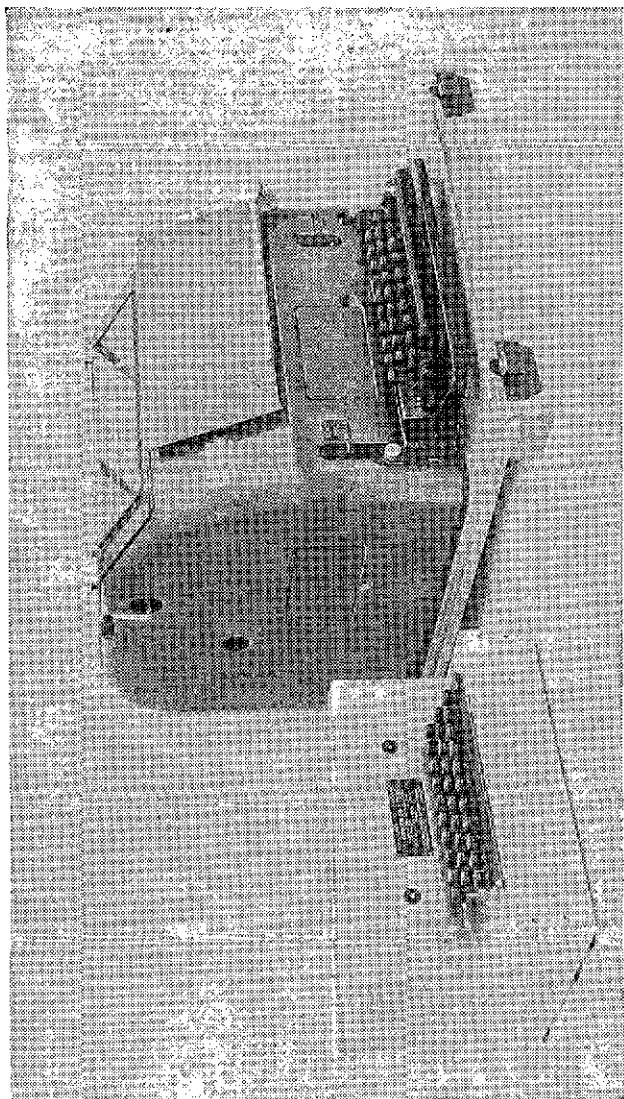

Figure 76.—Telegraph printers.

telegraph terminal of the second telephone circuit. This provides an all-metallic path for the telegraph circuit.

■ 228. GROUND CONNECTION.—In the usual case in which a ground return circuit is used, a good low-resistance ground connection is necessary for each terminal station not only to insure sufficient operating current, but also to prevent interference with neighboring telegraph circuits. It is almost always possible to obtain a good ground by proceeding as follows:

a. Drive a metal ground rod about 2 feet in length well into the ground where it is moist. Use a longer rod if one is necessary and available. Usually the ground near the roots of a shrub, cactus, or other vegetation is moist. If only dry ground is available, wet it thoroughly and pack it down around the rod.

b. Use a separate ground for each telegraph set or other equipment and keep separate grounds at least 15 feet apart.

c. Use two or more ground rods at least 15 feet apart connected together for a single set if one ground rod will not suffice.

d. Keep the wire leading from the ground rod to the set as short as possible, but do not hesitate to use a wire several hundreds yards long if necessary to reach moist ground, such as a stream bed.

■ 229. BRIDGING SIMPLEXED CIRCUITS AROUND A SWITCHBOARD.—When a circuit which is to be simplexed for telegraph passes through an intermediate switchboard at which no telegraph set is to be located it is necessary to make the simplex circuit continuous by bridging it around the switchboard. This is done without affecting the telephone circuits by installing a repeating coil for each section of the circuit on either side of the intermediate switchboard and connecting their telegraph terminals together.

■ 230. WAY STATIONS.—Intermediate stations located between the terminal stations on a telegraph circuit are called way stations. Not more than one or two way stations are normally used on field telegraph circuits. A way station may be installed at any point in the circuit, but normally

is installed at a location where there is a telephone switchboard. The connections to be made at the way station depend upon the type of telegraph set used (par. 231).

■ 231. TYPES OF FIELD TELEGRAPH SETS.—There are three types of telegraph sets in common use on field wire systems: the telegraph set TG-5, and TG-5-A, and the buzzerphone EE-1-A. For the installation, operation, and maintenance of the telegraph set TG-5, see TR 1230-1; of the telegraph set TG-5-A, see TR 1230-2; and of the buzzerphone EE-1-A, see TR 1230-5.

■ 232. ESTABLISHING TELEGRAPH COMMUNICATION.—*a.* The greatest difficulty in establishing communication over a telegraph circuit comes from the inability of an operator at one end to tell when the distant operator is on the line and attempting to transmit or receive signals. A definite procedure should therefore be agreed upon by operators to use when attempting to establish communication over a new circuit, as is often required after a movement of command posts.

b. When no other means of communication is available it will be necessary for each operator to adjust his instrument for most sensitive operation, connect it to the line, and alternately listen and transmit until he succeeds in communicating with the distant operator. If a definite time is agreed upon for starting operation, there is a better chance of establishing communication successfully.

c. If telephone communication with the distant operator is possible, one operator should call the other by telephone and indicate that he is ready to operate and that he will attempt to establish communication by telegraph. If convenient, the telegraph circuit may be used for this purpose by connecting a telephone EE-4 in series with the telegraph instruments at each end. If a telephone EE-5 or EE-8 is used it must be connected in parallel with the instrument so that the condenser of the telephone will not open the telegraph circuit. The telephone may be left connected to the line during the process of adjusting the telegraph instruments without seriously affecting the telegraph operation. When telegraph communication has been successfully established, the telephone is removed.

■ 233. TELEGRAPH OPERATING PROCEDURE.—Operating procedure for field telegraph sets is the same as radio procedure. (See ch. 5.)

SECTION V

MAINTENANCE OF FIELD WIRE SYSTEMS

■ 234. GENERAL.—*a.* Maintenance of a field wire system includes the prevention, location, and correction of trouble in the system. Trouble may be prevented to a large extent by the following actions:

(1) Routing of wire lines and locating of centrals and stations so as to avoid hostile shell fire as far as practicable, and to protect the lines and equipment from injury by friendly troops and traffic.

(2) Careful handling of wire equipment and its protection from moisture while in storage, in transit, and after it is installed.

(3) Training of all operating and using personnel in the proper use and care of wire equipment.

(4) Conference between communication officers of tank units and supported infantry units with reference to the location of wire lines.

b. Trouble that occurs on field wire systems is of two classes—that which causes an interruption to service, and that which is located and cleared before an interruption to service occurs. Most trouble may be kept in the latter class by an alert maintenance crew making proper routine tests. When trouble occurs it is located and cleared as soon as possible by methodical locating procedure and proper repair or replacement of equipment. All trouble, whether detected by operating and maintenance personnel or reported by users, is recorded and followed up until cleared. Clearing of trouble on wire lines is facilitated by the establishment of test stations at important junctions and at points near which trouble is anticipated.

■ 235. ROUTINE TESTS.—*a.* The frequency with which routine tests of circuits and equipment should be made varies, and is determined by the nature and importance of the circuits, the type of equipment and its manner of installation,

the amount of traffic being handled, and the amount of trouble being experienced. The frequency of these tests is prescribed by the signal or communication officer. All local and trunk circuits and the operating equipment connected to them or used in their operation are included in these tests. In general, circuits that are kept busy do not require as frequent routine tests as those that are seldom used. Communication is never interrupted to make a routine test. The fact that communication is being carried on satisfactorily over a busy circuit indicates that it is not in trouble and is the equivalent of a routine test. Circuits that have been busy and suddenly become idle are always tested at the first opportunity by the switchboard operator.

b. The routine tests of trunk circuits ordinarily are made by the wire chief, although they may be made by the switchboard operator if it does not interfere with the prompt handling of traffic. The test includes a check to see that each switchboard can be signaled from the other over all circuits between them, and that the voice transmission in each direction over the circuits is clear and satisfactory.

c. The routine tests of local circuits are ordinarily made by sending to the local telephone a maintenance man who tests back to the wire chief or switchboard operator. The test includes a check that the switchboard can be signaled from the telephone and vice versa, and that the voice transmission in both directions over the circuit is satisfactory. In cases where it is impracticable to send a man to the local telephone, as might happen in the case of a long circuit, the user is called and requested to make the test. Ordinarily, however, users are not disturbed in making routine tests of local circuits.

d. A record of all tests made and troubles found or reported on trunk circuits is kept on a form as shown below by the wire chief or chief operator at each telephone central.

TEST AND TROUBLE RECORD

STATION _____ DATE _____

Circuits tested every _____ minutes

CIRCUIT	TESTED		CLEARED		REMARKS (Nature of trouble, etc.)
	TIME	BY	TIME	BY	

CHIEF OPERATOR

TL-727

■ 236. **CIRCUIT TROUBLES.**—*a. Character.*—Trouble on a field wire circuit is indicated when it is impossible to signal or be signaled, when it is impossible to hear or be heard, or when the transmission is weak or is interfered with by noise on the circuit or crosstalk from other circuits. A knowledge of the character of troubles and the manner in which they affect transmission will materially aid in localizing the troubles when they occur.

b. Cause.—The trouble may occur either in the line wire itself or in the operating equipment attached to it, and will usually be found to be due to an open, a short, a ground, or a cross at one or more points in the circuit.

(1) The *open* is a break or cut in the conductor, either on one or both sides of the circuit.

(2) The *short* is caused by electrical contact between the two conductors of a circuit. It may be the result of bruised or stripped insulation which either permits the bare wires to touch each other or permits them to conduct electricity from one to the other when wet.

(3) The *ground* occurs when there is an electrical path to earth from one or both conductors of the circuit. It also

may be the result of bruised or stripped insulation or a poorly taped splice where the wire is lying on the ground. The effects of grounds will be most pronounced in wet or damp weather.

(4) The *cross* is caused by electrical contact between conductors of two adjacent circuits and is in reality a short between a conductor of one circuit and a conductor of the other.

c. Effects on telephone transmission.—(1) An open will interrupt telephone communication completely. However, a partial open, such as results from a poorly made splice or a loose contact which introduces a high resistance in the circuit, may not destroy communication completely, but the transmission will be weak and probably noisy.

(2) A heavy or low resistance short will interrupt telephone communication completely. A partial or high resistance short will result in weakened transmission.

(3) A ground on both sides of a circuit will produce an effect similar to that of a short described in (2) above. A ground on only one side of a circuit will not usually interrupt telephone communication, but may produce hum or noise in the circuit.

(4) A cross is likely to result in crosstalk or interference between the two circuits involved which may or may not be sufficient to render the separate conversations unintelligible.

d. Effects on simplex telegraph operation.—It will be observed that a simplex telegraph channel may continue operative under certain trouble conditions which render the physical circuit on which it is superimposed inoperative for telephone communication, thus emphasizing again the value of the simplex telegraph channel. For example, the simplex telegraph circuit will work, or may be made to work, by the addition of battery in the case of the telegraph set TG-5 or TG-5-A even though one side of the physical circuit is open; a short on the physical circuit will not affect the telegraph channel adversely; an accidental ground on one or both sides of the physical circuit will not render the telegraph channel inoperative generally unless the ground is of unusually low resistance; a cross is not likely to interfere with the

telegraph channel unless both of the circuits involved in the cross are simplexed and even then does not necessarily render the telegraph channels inoperative.

■ 237. **EQUIPMENT USED FOR TESTING.**—The nature of the trouble on a field wire circuit or in operating equipment can be determined with any of the following equipment in the manner described for each.

a. Field telephones.—Any field telephone may be used for testing line or equipment circuits. For convenience in making tests the telephone is equipped with a pair of test leads made of lamp cord, field wire, or other flexible twisted pair wire about 3 feet in length. A test clip is soldered to one end of each conductor, and if stranded wire is used the other end which is to be connected to the line terminal of the telephone is soldered lightly to hold the strands together and prevent accidental shorts at the telephone terminals. The following tests may be made:

(1) *Test for an open.*—Connect the ends of the circuit to the line terminals of the test telephone and turn the generator crank rapidly. If the generator crank turns quite freely without any drag on it the circuit is probably open.

(2) *Test for a short.*—With the telephone connected as above, if the generator turns quite hard, as if a drag had been placed on it, the circuit is probably shorted or grounded on both sides.

(3) *Test for a ground.*—Connect one side of the circuit to one line terminal of the telephone, and connect the other line terminal of the telephone to ground. If there is a ground on that side of the circuit, the generator will turn hard as in the case of a short. Test the other side of the circuit in a similar manner.

(4) *Test for a cross.*—Connect one side of the circuit to one line terminal of the telephone and the other line terminal of the telephone to the conductor with which the circuit may be crossed. If there is a cross the generator will turn hard as in the case of a short. Test each side of the circuit in a similar manner with any conductor with which it might be crossed.

b. Test set EE-65.—Testing of field wire circuits and equipment can be facilitated by the use of the test set EE-65

if one is available. For instructions covering the use of this test set see TR 1265-10.

c. *Voltmeter and battery* (fig. 77).—A simple arrangement for testing equipment circuits consists of a voltmeter and battery connected in series and equipped with wire leads. The terminals of the wire leads may be fitted either with test clips or short lengths of stiff copper wire for convenience in making contacts with the equipment circuits. This apparatus is suitable for making the following tests:

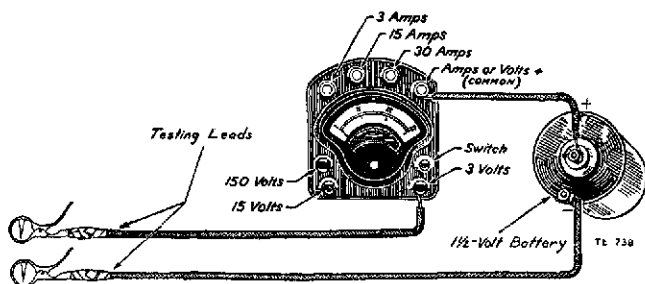

FIGURE 77.—Voltmeter and battery for use in testing circuits.

(1) *Test for a complete circuit.*—Connect the test leads to the ends of the circuit to be tested. If the circuit is complete the voltmeter needle will indicate a reading.

(2) *Test for an open.*—Connect the test leads to the ends of the circuit to be tested. If the circuit is open, the voltmeter needle will *not* indicate a reading.

(3) *Test for a short.*—Connect the test leads to the ends of the circuit to be tested. Open the other end of the circuit. If the circuit tests short, the results will be the same as for a complete circuit ((1) above).

(4) *Test for a ground.*—Connect one test lead to the circuit to be tested. Connect the other test lead to ground. If the circuit is grounded, the results noted will be the same as for a complete circuit ((1) above).

(5) *Test for a cross.*—Connect one test lead to the circuit to be tested. Connect the other test lead to the circuit with which the circuit to be tested is believed to be crossed.

If the circuit is crossed with the other circuit, the results noted will be the same as for a complete circuit ((1) above).

d. Receiver and battery (fig. 78).—A telephone switchboard receiver connected in series with a battery and fitted with leads may also be used for testing equipment circuits. The terminals of the test leads may be equipped either with test clips or short lengths of stiff copper wire. The apparatus is suitable for making the tests outlined for the voltmeter and battery in *c* above. However, instead of a read-

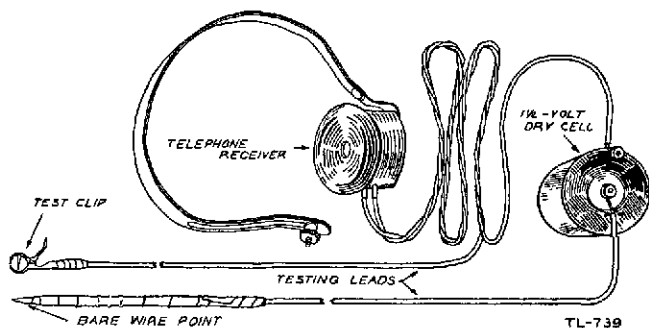

FIGURE 78.—Receiver and battery connected for use in testing circuits.

ing indicating a complete circuit, in this case when the circuit is completed by touching or connecting the test leads, a click in the receiver indicates a complete circuit. A failure to obtain a click on completing the circuit indicates an open circuit.

■ 238. LOCATING AND CLEARING TROUBLE.—*a. General localizing of trouble.*—When trouble is detected or reported on a circuit, the first step is to determine whether it is located in the line wire itself or in the operating equipment. This is accomplished by clearing the line wire from the terminal equipment at the terminal strip and making the tests from that point toward the switchboard. If these tests show no trouble in the operating equipment, the trouble may be assumed to be either in the line wire itself or in the operating equipment at the distant end. This is verified by connecting

the test equipment to the line and testing toward the distant end of the circuit. In the case of a trunk circuit, the trouble may be still further localized, providing an additional good circuit is available, by requesting the wire chief at the distant end to clear the faulty circuit from the operating equipment at that end. In the case of a short local circuit a maintenance man is sent to clear the instrument from the end of the line. The circuit is then tested again—for an open with the distant ends of the circuit open, and for a complete circuit with the distant ends of the circuit connected together. If the trouble is in the line wire itself it will appear upon making these tests, and it is located and cleared as described below. If these tests show the line wires to be good, the trouble is in the operating equipment at the distant end and the wire chief there is so notified and requested to clear the trouble and reconnect the circuit.

b. Short local circuit in trouble.—If, upon making the first test described above at the terminal strips, the trouble is found to be toward the user's telephone, reconnect the circuit and dispatch a troubleman with a serviceable telephone to the user's instrument. On his way he inspects the circuit for visible sources of trouble, and repairs any that he finds. He then makes a ringing and talking test with the user's telephone. If he cannot signal the operator with it, he replaces the local instrument with his own instrument and repeats the test. If he can now signal and converse with the operator, the trouble was in the local telephone which is either repaired or replaced by him. If he cannot signal the operator, the trouble is probably in the local line circuit, and he first tests for a short and an open circuit, then tests for a grounded circuit, and, if applicable, tests for a cross with another circuit. If trouble is located in the line wire, he works back toward the telephone central, making a careful inspection of the line wire, paying especial attention to splices and other doubtful points over its entire length. If the fault is located, he repairs it and notifies the user that the service is again available. If careful inspection does not readily disclose the fault, time may be saved by running a new circuit. This circuit is then connected into the switch-

board, the local telephone connected at the end of the circuit, and the new installation tested.

c. Trunk circuit or long local circuit in trouble.—(1) If the tests described in *a* above determine that the trouble is in the line wire of a trunk circuit or in a long local circuit, the wire chief determines as accurately as his instruments permit the nature and approximate location of the trouble. This will facilitate the testing and materially shorten the time required to locate and clear the trouble.

(2) The circuit is then connected to a test telephone at the switchboard terminal strip, or left connected into the switchboard if there is not sufficient maintenance personnel available to man the test telephone. A lineman is then sent out on the line with a test telephone to test methodically from various points back to the man at the switchboard terminal strip or to the switchboard operator. Starting from the switchboard terminal strip, he carefully examines the circuit as he proceeds, particularly scrutinizing the insulation, splices, underground and overhead road crossings, and places where the wire has been passed over or pulled out of place by traffic. Fouled insulation, poor splices, and other evidences of possible trouble are repaired and the circuit tested in order to determine if the trouble has been cleared. If no such points of obvious trouble are found, the lineman bridges his telephone across the circuit at intervals and tests.

(3) If testing the defective circuit for an open, he connects the test telephone across the circuit without opening it. If testing for a ground or a short, he opens the circuit and then tests in both directions. Before opening the circuit however, he connects his telephone to it with the test clips and attempts to communicate in either direction as there is a possibility that the trouble has been cleared in the meantime by other personnel. In case it is necessary to open the circuit, it is opened at a splice or at a test station if practicable. After making each test the circuit is reconditioned by taping wherever a test clip has been connected to it, or by splicing and taping wherever the wire was cut.

(4) Upon making each test the lineman himself can determine whether the circuit is good between his location and the central by his ability to ring and talk to the man at the

switchboard terminal strip or the operator. If any test toward his own central is successful, the fault still lies beyond in the direction of the distant central and the lineman continues to work in that direction. If he is unsuccessful in reaching his own central during any test, he has passed the fault and therefore works back over the circuit, reducing the distance between successive tests to about one half. By following this procedure the fault is located between two points a short distance apart. This section of the line is then carefully inspected until the actual fault is located. It is then repaired by splicing, by cutting out and replacing the faulty section, or by simply taping as required.

(5) A defective circuit may have more than one case of trouble. These may be of the same nature or different. It is essential that the lineman, after clearing each case of trouble, test the circuit in both directions to insure that it is in order. If trouble still exists he continues his inspection until all trouble has been located and cleared.

(6) The time consumed in splicing a circuit after each test for a short or ground is considerable, and will seriously delay the ultimate locating of a fault if such tests are made at too frequent intervals along the circuit when first starting out. Furthermore, a visual inspection of the circuit by the lineman as he progresses along its route will frequently disclose the fault. A knowledge of the geographical location of a circuit will aid the wire chief in predicting the probable location of a fault, having determined its nature. He may direct the lineman to make tests from the vicinity of such points or may specify the approximate interval for making tests. A good rule, otherwise, is to test each time a portion of the circuit has been passed which could not be visually inspected.

d. Removing trouble.—In repairing a circuit in the field, speed in restoring service comes first and proper technique in splicing next. When repairing a break in a line, communication is first restored by completing the square knot in each wire. Then while the bare wires are kept separated to prevent a short, the splice is completed and taped. A valuable addition to the equipment of a lineman consists of two short pieces of wire about 3 feet in length with test

clips on each end. These jumper wires are used to bridge a break during the construction of a splice, thus keeping the circuit in operation. In using jumper wires care is taken that a short circuit is not caused while splicing. In locating trouble, linemen are sent out from each end of the circuit and work toward each other. The wire chiefs at both ends are responsible that it is cleared, regardless of at which end the trouble was first discovered. In addition to pliers, tape, and test telephone, each lineman carries a 50-foot coil of field wire with which to repair a defective section if found.

e. Trouble in local operating equipment.—If the trouble was originally determined to be toward the operating equipment at the central, it may be localized by opening the circuit at various places such as the line terminals, fuses, protectors, etc., and the tests repeated. Terminal strips and connections are inspected carefully for shorts and opens and crosses. If the trouble is in the equipment itself it can be located by a rigid system of testing such as prescribed for that specific piece of equipment elsewhere in this manual or in the Technical Regulations relating thereto. In the case of a faulty unit in a switchboard, its use should be discontinued and the circuit transferred to a spare unit if available until repair or replacement can be made.

■ 239. OPERATION OF TEST STATIONS (par. 171).—*a.* The personnel at a test station consists of one or more linemen as the situation requires. A test telephone is kept bridged across a circuit, usually the lowest numbered telephone circuit passing through the test station, or on a special circuit ending at the test station and temporarily reserved for test purposes. The personnel on duty at the test station is instructed to answer prearranged signals only, usually three short rings. When this prearranged signal is answered, the test station personnel gives the name of the test station. The test station personnel is then instructed as to patching, testing, or repairing circuits, as the situation requires.

b. Test station personnel keeps informed constantly as to the serviceability of the circuit across which the test telephone is bridged by listening for the normal signaling and conversation that is passed over the circuit. If the circuit becomes idle it is tested promptly and frequently there-

after. In case these tests show the test circuit to be in trouble, the test telephone is bridged across another circuit and an attempt made to report to the switchboard operator or the wire chief.

c. Locating and clearing trouble on defective circuits which pass through test stations manned by linemen is facilitated by the fact that the wire chief can call each successive test station and quickly determine the section of the line in which the trouble lies. The nearest test station can then be directed to dispatch a lineman to locate and clear the trouble. In the meantime serviceable sections of two or more unserviceable circuits can be patched through a test station, to provide at least one complete serviceable circuit out of sections of two or more unserviceable circuits (par. 240). A copy of the circuit diagram and line route map

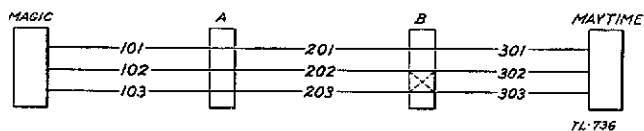

FIGURE 79.—Circuits patched at a test station.

indicating all circuits passing through or ending at the test station is kept posted at the test station.

■ 240. PATCHING CIRCUITS AT TEST STATIONS.—*a.* The patching of circuits at test stations frequently results in maintaining communication between centrals over these patched circuits during the locating and clearing of trouble on the defective sections of the original circuits. If this patching were not done, communication would be interrupted until the trouble had been cleared. The example in *b* below illustrates a case where patching may be used advantageously.

b. Assume that two telephone centrals are connected by three circuits, all of which pass through two test stations as shown in figure 79. The telephone switchboard operator at MAGIC reports to the MAGIC wire chief that circuits 102 and 103 to MAYTIME are out of order. The wire chief at MAGIC tests these two circuits with the aid of a serviceable circuit to his test stations. He finds that the trouble on the 102 circuit lies in section 202, between test station

A and test station B, and that the trouble on the 103 circuit lies in section 303 between test station B and MAY-TIME. He then instructs the lineman at B to remove the jumpers connecting circuit 202 to circuit 302, and circuit 203 to circuit 303; and to jumper circuit 203 to circuit 302, and circuit 202 to circuit 303. This gives immediately one serviceable built-up circuit from MAGIC to MAYTIME in addition to the 101-201-301 circuit. The MAGIC wire chief informs the lineman at A and the MAYTIME wire chief of the changes made at B so that all circuit diagrams can be temporarily changed accordingly. When the interrupted circuits have been repaired the wire chief is notified. Upon instructions from him the original connections are restored during an interval between busy periods, and all concerned are notified to this effect.

■ 241. PATROLLING WIRE LINES.—In shelled areas or where wire lines are subject to frequent damage from other causes, periodic testing from designated points is supplemented by patrolling the sections most subject to damage. Whenever possible, the personnel that has constructed a given section is also assigned the mission of patrolling that section. Wire patrols to be effective must carefully inspect every foot of the wire in the sections they cover. This is made possible by the use of the wire pike or an improvised wire guide made by fastening a bridle ring to a hand grip. Wire patrols repair trouble whenever found. They replace doubtful splices or sections of the line, tape abrasions in insulation, and wherever possible they improve the construction.

■ 242. TESTING FIELD WIRE ON REELS.—All insulated wire is carefully reconditioned after use, as follows:

a. Mount an empty reel and the reel containing the wire to be tested, so that the wire may be wound from the full reel on to the empty reel.

b. Pass the end of the wire through the hole provided near the drum of the empty reel and secure it so that the end will protrude from the side of the reel. This end must be free for use in future testing.

c. Station an experienced man between the reels to examine the wire carefully as it is slowly wound on to the

empty reel. Cover with tape each abrasion or break in the insulation. If only the braid is broken, apply two layers of friction tape. If the bare wire is exposed, remove the ragged portions of insulation and cover the wire with two layers of rubber tape and two layers of friction tape as described in paragraph 186 *a* (7) and (8). Carefully splice breaks in the conductor. Untape and examine each old splice; if the splice is poorly made, cut it out and splice the wire properly. If the insulation has been damaged over a long section of the wire, or if there are several splices very close together, cut out the faulty section.

d. After each splice, and also when all the wire of a reel is completely repaired, test the wires on the reel being filed for an open circuit or a short circuit between the two wires. These tests may be made by any of the equipment used for testing as described in paragraph 237.

■ 243. DRY BATTERIES.—*a. General.*—Dry batteries are the principal source of power for field wire equipment, and weak or run down batteries render this equipment inefficient. The date of manufacture of a dry battery is ordinarily stamped on it, and it deteriorates rapidly in use and slowly when not in use. It is always suspected as the cause of trouble when equipment in which it is installed begins to decrease in efficiency.

b. Characteristics.—Some characteristics of the most commonly used dry batteries are given in the following table:

Battery	Identification of terminals		Open-circuit voltage
	Positive	Negative	
BA-1.....	Top, center.....	Zinc case.....	3.0
BA-2.....	Red.....	Black.....	22.5
BA-8.....	do.....	do.....	22.5
BA-9.....	Short strip.....	Long strip.....	4.5
BA-17.....	Top, center.....	Zinc case.....	1.5
BA-30.....	do.....	do.....	1.5
BA-32.....	Stamp on socket on top of battery for 5-pin plug.		As stamped on top of battery.

c. Storage.—(1) The number of dry batteries in storage is kept as low as possible by anticipating requirements, and

requesting small periodic shipments to meet the requirements.

(2) Deterioration is minimized by storing dry batteries in a cool, dry place, and by keeping them clean.

(3) Since deterioration of a dry battery is sure to damage equipment in which it is installed, the battery is always removed from equipment not in use and is stored separately.

(4) The oldest batteries in storage are issued first, and stocks are arranged to assure such issue.

d. Test.—(1) *Under load.*—The best obtainable indication of the condition of a dry battery is its voltage while it is supplying normal current. If it is in good condition, its voltage should be only slightly less than the open circuit voltage given in *b* above.

(2) *Open circuit.*—Since the open circuit voltage of a worthless dry battery may be equal to that given in *b* above, measuring the voltage of a battery when it is not supplying current may in some cases give little indication of its condition. Nevertheless, when a voltmeter is available, this voltage is measured as a matter of routine before a battery is installed, because if the open circuit voltage is less than 90 percent of that given in *b* above, the battery is practically useless.

■ 244. REPEATING COILS.—Repeating coils are designed to withstand moisture and a certain amount of rough handling. They are subject to failure, due to broken connections and corroded or dirty terminals. Repeating coils are inspected before installation, for broken or loose connections outside of the metal cover. During the inspection, loose or broken connections are resoldered, and corroded or dirty terminals are thoroughly cleaned and brightened with sandpaper or emery cloth. Repeating coils are completely tested as follows:

a. Clean the terminals and replace loose connections outside of the metal cover.

b. Connect two repeating coils by short pieces of wire of equal length, as described in paragraph 212, for simplexing. Then connect four serviceable telephones to the two coils, one pair of telephones to the metallic circuit, and one pair of telephones to the ground return circuit. The test con-

sists in ringing and talking over each circuit. If unable to ring or talk over either circuit, test each of the jumpers between each binding post and the corresponding coil terminal, both for continuity and for cross with any other jumper. If the jumpers are clear of trouble, the trouble is probably in the coil windings which are inside the iron case.

c. If the first test shows that both circuits are clear, ring and talk over each circuit while listening over the other circuit. If the ringing or talking over one circuit can be heard over the other circuit, the coil is defective. Do not remove the iron case, but turn the repeating coil in for repair.

■ 245. TRANSPORTATION OF WIRE EQUIPMENT IN THE FIELD.—*a. Operating equipment.*—Operating equipment is comparatively delicate, and its serviceability is governed to a great extent by care in methods of packing it for transportation. Operating equipment is packed and loaded in such manner as to protect it from—

- (1) Dust and dirt.
- (2) Weather.
- (3) Shocks of the road.
- (4) Injury from other articles loaded in the same vehicle.

b. Telephones are packed in pack chests when provided. Telephones EE-4 are packed with the hook switch turned in, crank handles turned up so as to be flush with the case, handset cord neatly wound around handset, and handset inserted in the case with the receiver end down, the lid closed and latched, and the carrying strap tightly buckled and coiled on top of the lid. Telephones EE-5 are packed in the same manner except that the crank is removed from the generator shaft and placed under the spring catch provided on the panel of the telephone. Care is exercised in winding the cord around the handset to see that it does not press on the button switch on the side of the handset.

c. Switchboards.—Monocord switchboards with cable and switchboard terminal strip attached are packed in a pack chest separate from telephones. Before placing in the pack chest, the switchboards are placed in their carrying cases with shutters locked and cable neatly coiled.

d. Repeating coils, loading coils, terminal strips, spare batteries, and spare parts are carried in the pack chests pro-

vided, packed in such manner as to prevent injury to themselves or other equipment in the same chest.

e. Buzzerphones are carried in cases of more sturdy construction than those used for other operating equipment, and they may be packed outside of special pack chests without danger of injury. However, where pack chests are available, it is desirable to use them for packing this equipment as a more compact and more easily handled load results.

f. Wire.—The principal precaution necessary in transporting wire is that the metal drums or commercial spools should not be dropped from vehicles or handled in such a manner as to injure or bend them and thereby make difficult their refilling and use.

CHAPTER 9

SIGNAL SUPPLY

■ 246. GENERAL.—*a.* For general information and instructions regarding division supply, see Staff Officers' Field Manual.

b. Signal supply differs only slightly from other supply within the division. Responsibilities of commanders therefor are the same as for other supply. Principal supply duties of the division signal officer are given in paragraph 12 and the most important publications relating to signal supply are listed in paragraph 4.

■ 247. CLASSIFICATION.—All signal supplies issued to division units are normally in class III and the methods which follow are based on this premise. In exceptional situations, some signal supplies might properly fall into other classes. The items which most likely fall into other classes are shown below:

a. Class II.—Pole climbers and linemen's gloves.

b. Class IV.—Dry batteries, message books, friction and rubber tape, field wire; supplies for cable, pole, and trench line construction, and for radio and other installations not usual within the division.

■ 248. DIVISION PERSONNEL.—The supply officer of the division signal company or troop is the principal supply assistant of the division signal officer. The supply and transportation personnel and facilities of the company or troop are utilized for division as well as for company or troop supply purposes. Supply officers of all division units may deal directly with the division signal officer on signal supply matters within the limits of policies prescribed by the commanders concerned.

■ 249. REQUISITIONS.—All signal supplies are obtained on requisition.

a. Requisitions are submitted at definite dates to cover needs for specified periods, and at as early dates as possible

to cover needs which could not be foreseen in time to permit their inclusion in periodic requisitions.

b. Requisitions bearing the approval of commanders are submitted to the division signal officer by the supply officer or officers of—

(1) *A regiment.*—One requisition for the consolidated needs of the regiment.

(2) *A brigade headquarters.*—One requisition for the consolidated needs of brigade headquarters.

(3) *Special troops.*—One requisition for the needs of each unit of special troops except the division signal company or troop.

(4) *The signal company or troop.*—For the needs of the company or troop.

c. Nomenclature of all items will conform to that prescribed in Tables of Basic Allowances or in the Signal Corps General Catalog.

d. Quantities requisitioned will not exceed those authorized in Tables of Basic Allowances unless justification for the additional needs is included. Needs of lower units which can be met from supplies in the hands or under the control of supply officers are not included in requisitions submitted by those officers.

e. The division signal officer—

(1) Checks to see that all requisitions are received by him at the times specified. If any are missing, he initiates action to obtain them and to assure their future timely receipt.

(2) Edits all requisitions for quantity, authenticity, nomenclature, and form, and takes action relative to the supply thereof.

(3) If any needs can be met by using supplies on hand in the division signal company or troop or in other units in excess of their reasonable requirements, authorizes issues of such supplies.

(4) Prepares one consolidated requisition for the unfilled needs of the entire division, obtains the approval of the division commander, and forwards same in accordance with instructions of higher authority.

(5) Informs unit commanders of the action taken on requisitions submitted by their units.

■ 250. RECEIPT.—Signal supplies are received by the division at railheads or other refilling points. The division signal officer is informed of such receipt, but by frequent inquiry, if necessary, assures himself that information thereon is promptly obtained by him. He takes control of the supplies at the refilling point.

■ 251. TRANSPORTATION.—*a. From refilling point to distributing point.*—Transportation for signal supplies from the refilling point to the division signal distributing point and to the organization bivouacs is normally furnished from cargo vehicles available to the division commander. In an emergency, the division commander may direct the use of transportation of the signal company or troop for this purpose.

b. From distributing point to units.—Transportation from the distributing point to units is furnished by organic vehicles of the units.

■ 252. ISSUE.—*a.* The division signal officer causes issues to be made to requisitioning units either at the distributing point or, if necessary because of unusual transportation methods, at the refilling point or organization bivouacs.

b. The quantities of signal supplies authorized for the division signal company and troop are the minimum necessary for their proper functions, and the use of those supplies to meet the needs of other units is not normal. However, in unusual situations, emergent needs of lower units are balanced by the signal officer against those of the signal company or troop, and if necessary, are met to some extent from those supplies. In such cases immediate action is initiated to replenish the supplies so issued. To release the combat train of the division signal company or troop for its combat mission, it is necessary to dump some or all of the unit supplies at a point convenient to the unit. This point is located near the division command post.

■ 253. STORAGE BATTERIES.—*a.* In units not equipped with charging sets, the storage batteries authorized solely for use with communication equipment are serviced by the division signal company and troop.

b. The division signal officer provides for the collection, charging, and distribution of these batteries. Batteries

should always be fully charged before the beginning of a tactical operation.

c. The charging and maintenance of storage batteries installed in a vehicle and used jointly in the operation of the vehicle and of signal equipment installed therein, is the responsibility of the arm or service charged by AR 850-15 with the maintenance of the vehicle.

d. For further details, see TR 1190-5.

■ 254. PIGEONS.—When pigeons are assigned to a division, the division signal officer takes the action prescribed in paragraph 87.

■ 255. REPAIR OF EQUIPMENT.—While much of the signal equipment issued is simple and usually needs only minor mechanical or electrical repair, other items are inherently as delicate as precision instruments and require the attention of expert repairmen. In the latter case, the attempted repair of the equipment by an incapable repairman often results in greater damage to the equipment. The Signal Corps General Catalog and Technical Regulations provide guides to the repairs which should be attempted in the field. Repairs are accomplished as follows:

a. The extent to which repairs are permitted in any unit is determined by the commander of the unit after the receipt of advice from the division signal officer. This determination is made only after a consideration of the tools and testing equipment available in the unit and of the capabilities of available personnel.

b. Using units habitually replace unserviceable batteries, cords, tubes, easily accessible assemblies, nuts, bolts, screws, straps, and other simple mechanical parts.

c. Equipment which is not repaired in lower units is turned in for repair or replacement to the division signal company or troop which has limited but usually better repair personnel and facilities. If needed repairs are beyond the immediate capabilities of those units, the signal officer takes immediate steps to secure replacement and conforms to instructions of higher authority in obtaining the repairs.

CHAPTER 10

ORDERS, RECORDS, AND REPORTS

■ 256. GENERAL.—For further information on this subject, see Staff Officers' Field Manual.

■ 257. ORDERS.—Signal communication personnel are required to interpret and execute the instructions contained in routine orders and combat orders. (See Staff Officers' Field Manual for classification of orders and forms.)

■ 258. RECORDS AND REPORTS.—*a. Unit journal.*—Signal units of division and higher headquarters keep a journal during operations in the field. The journal is a day book containing briefs of important written and oral messages received and sent and notations of periodic reports, orders, and similar matters that pertain directly to the signal unit. Copies of messages and other data pertaining to the signal unit and furnished by it for purposes of information to sections of the unit are not entered in the journal. Communication units may keep a similar journal but rarely find it necessary to do so. (See form for a signal unit journal on page 261.)

b. Circuit diagram.—A consolidated circuit diagram is kept by signal communication troops of the unit headquarters to show the wire system of the unit and those of its subordinate units. A circuit diagram also serves as a convenient method of reporting to the next superior headquarters the wire system installed by the subordinate unit. (See par. 173.)

c. Line route map.—A consolidated line route map is kept by signal communication troops of the unit headquarters to show the routes of the wire lines of the unit and those of its subordinate units. A line route map also serves as a practical and convenient method of reporting to the next superior headquarters the routes of the wire lines installed by the subordinate unit. (See par. 175.)

d. Miscellaneous.—Message center records, telephone central records, records of radio and telegraph stations, and other operating agencies are collected by the signal or communication officer from each operating agency at frequent intervals and upon the termination of business each day. (See par. 34c.) Such records contain useful information for the operations section of the staff and form the basis for special reports.

■ 259. STEPS INVOLVED IN EACH TACTICAL OPERATION.—The solution of any situation demanding action requires that certain definite steps be taken in a logical sequence.

a. Mission.—The signal mission is the particular duty required of signal communication troops. The commander may give his signal or communication officer definite instructions as to what signal communication he desires or he may restrict the mission of the signal or communication officer by directing that only certain agencies be employed. In most cases, however, this mission is seldom stated by the commander. It is more or less routine and is usually deduced from the commander's directive to his staff.

b. Estimate of the signal situation.—The signal or communication officer makes an estimate of the signal communication situation in order to arrive at his recommendations concerning the signal activities of the command. He first considers his mission; he next considers so much of the enemy situation as may affect his commander's signal communication; then the tactical decision and so much of the friendly situation, including the signal situation, as has a bearing on the furnishing of the signal communication desired for the operation; and lastly, the several plans open to the commander for providing adequate signal communication for the contemplated tactical operation. From as complete an analysis of these considerations as time permits, the signal or communication officer makes his decision as to the recommendations he will make to his commander for providing signal communication for the tactical operation planned. (See check list, page 258.)

c. Plan.—When time permits, the recommendations are submitted to the commander in the form of a plan of signal communication. Actually whether the plan is submitted

directly to the commander or first to G-3 (S-3) depends upon the operating methods of the particular staff. Since G-3 (S-3) is charged with supervision of the signal system, it is considered better practice to submit this plan to him. The plan relates to the following:

- (1) Paragraph 5 of the field order.
- (2) Time the signal system will be ready for operation.
- (3) Essential service to be provided.
- (4) Signal supply details affecting the plan.
- (5) Other items not included above.

d. Signal orders.—After the commander approves the plan of signal communication, the signal or communication officer works out the details necessary to place the plan in order form. The instructions to be included in paragraph 5 of the field orders for the command are furnished the operations section of the staff. This section is charged with the preparation of the field order. The plan, supplemented by other necessary information and instructions, is issued as signal orders. These orders serve the sole purpose of coordinating the establishment of the signal system and agencies throughout the command and therefore contain only the necessary instructions to the signal communication troops of the command for this purpose. (See check list on page 259.) Signal orders may be issued as an annex to formal written field orders, and if so issued, that annex is ordinarily called the signal annex. (See par. 260*b*.) They may be issued in fragmentary form. When it is impracticable to prepare the signal orders in written form, they may be issued either as a dictated or an oral order, complete or fragmentary. A circuit diagram of the wire system is normally issued as an appendix to the signal orders. (See example on page 260.) A line route map may also be issued when sufficient time is available to permit of thorough reconnaissance, or when it is desired to indicate general routes of wire lines. (See example on page 262.) In units smaller than a division, the signal orders are normally oral and fragmentary, supplemented by such sketches as may be necessary.

e. Supervision.—The responsibility of the commander does not end with the issue of orders. Therefore, to secure proper compliance by subordinates and to assure himself that plans

of subordinates are in furtherance of his own orders, the commander may direct his signal or communication officer to supervise the execution of the orders which have been issued. Supervision is exercised by means of conferences and visits. Such conferences have as their object the promotion of mutual understanding, the correct interpretation of doubtful or obscure points, and the development of teamwork.

■ 260. FIELD ORDERS.—Field orders are issued by the commanders of all tactical organizations for each distinct operation. They contain instructions governing all tactical activities of the command during the combat operation for which the order is issued, including the establishment of signal communication. Signal communication troops are concerned primarily with paragraph 5 of the field order which contains instructions relative to the establishment and maintenance of signal communication.

a. Paragraph 5.—This paragraph of the field order contains instructions arranged in lettered subparagraphs and in sequence as follows:

(1) Subparagraph *a* refers to the signal annex, if one is issued. If signal orders are not issued as an annex, this subparagraph refers to the index to signal operation instructions in effect for the operation. If reference is made to the annex, further reference to signal operation instructions is unnecessary since the annex contains a statement indicating what index to signal operation instructions is in effect. Examples:

a. See Annex No 3, Signal Orders.

a. See Index No 7 to Signal Operation Instructions.
In addition, important instructions in the annex or in signal operation instructions may be repeated in this subparagraph to emphasize them. Examples:

All radio communication is restricted until the hour of attack, 4:48 AM, 14 November.

Pyrotechnic signal to fire barrage: Signal, ground, red star, cluster M6.

(2) Subparagraph *b* announces axes of signal communication for all tactical operations in which a displacement of command posts is contemplated. Axes of signal communica-

tion are prescribed by the higher unit for its principal next subordinate combat units, and for itself if no higher unit has already prescribed it. Example of subparagraph *b* for an infantry regimental field order:

b. Axes of signal communication:

1st Infantry: RJ 703-A (366.1-734.9)—RJ 561-A (367.1-732.8)—RJ 585-B (368.4-730.8)

1st Bn, 1st Inf: RJ 622-J (365-733.8)—RJ 600-F (365.8-731.8)—RJ 595-G (366.9-730.5)—RJ 538-M (369.2-729.6)

2d Bn, 1st Inf: House at (366.9-734.6)—RJ 585-I (367.2-733.5)—Woods at (368.8-732.7) southeast of LITTLE—RJ 740-M (370.1-731.7)

(3) Subparagraph *c* announces the initial location of the command post of the unit and prescribes an initial location for the next principal subordinate combat units. A command post location may be expressed in several ways, depending upon the situation. It may be expressed by stating a definite location or a definite position in a column. It may be indicated as being at a certain place after a certain hour. It may be shown as closing at one location and opening at a new location at the same hour. When it cannot be predicted where a subordinate combat unit will be able to establish its command post, it may be directed to report the location of its command post. Example:

c. Command posts:

1st Division: Closes at BONNEAUVILLE at 7:00 PM and opens at TWO TAVERNS at the same hour

1st Brigade: E. STRALEY (357.4-744.7) after 6:00 PM

2d Brigade: To be reported by 10:00 PM

(4) Subparagraph *d* announces instructions governing advance message center and march control points. Examples:

d. An Advance Message Center, 1st Division, will be established at CR 581-A (368.9-754.7) by 2:00 PM.

d. 1st Division will establish the following march control points for the movement of the main attack force:

CR 581-P (370.2-747.0), opens 5:30 PM, closes 10:00 PM

CR 601-A (363.6-746.5), opens 7:00 PM, closes 11:30 PM

CR 530-D (356-748.2), opens 8:30 PM, closes 1:00 AM night 14/15 November

(5) If no instructions are published pertaining to an indicated subparagraph, its letter designation is applied to the succeeding subparagraph.

b. Signal annex (par. 259d).—The signal annex contains the signal situation confronting the command as a whole, the mission to be accomplished by the signal agencies of the command as a whole, any missions other than routine assigned to the signal communication troops of the headquarters, any signal missions other than routine assigned to the commanders of next subordinate units, and any additional instructions for signal communication troops of the command necessary to coordinate the establishment of signal systems and agencies throughout the command.

(1) Signal annexes are prepared by signal officers of divisions. In units below the division signal orders are normally issued as dictated or oral orders, complete or fragmentary.

(2) The general form of signal annexes to formal written field orders follows that prescribed for field orders.

(3) A signal annex may be accompanied by one or more appendixes. Such appendixes may include a signal operation map to show geographically much of the information otherwise included under paragraph 1 of the annex, a circuit diagram, a schedule of messenger service, and a line route map.

(4) A signal annex is given the same distribution as the field order. In addition thereto, extra copies may be distributed to signal communication troops as required.

c. Orders of signal communication units.—The commander of a signal communication unit follows certain steps in each tactical operation. For the particular operation he finds his mission defined in the orders of the commander whose headquarters he serves. These orders include the field order and its accompanying signal orders. With his mission defined he makes an estimate of the situation and reaches a decision in order to adopt a plan of action. (See

check list on page 258.) In making this estimate he considers the allotment of tasks to the components of his organization and the methods available to install, operate, and maintain the signal agencies for the headquarters his unit is serving. The plan of action adopted is then put into order form for issue to his unit. (See check list on page 261.)

(1) In signal units of divisions and in communication units, field orders are usually issued as oral orders and often in fragmentary form.

(2) A circuit diagram of the wire system to be installed, operated, and maintained, and whenever practicable, a signal operation map indicating certain of the proposed signal installations and as much of the tactical plan as is required by signal troops, are issued as annexes to the field orders of signal units. When oral orders are issued, they are normally supplemented by a circuit diagram even though roughly drawn, and whenever practicable, are issued from a signal operation map.

■ 261. SIGNAL OPERATION INSTRUCTIONS.—*a.* Signal operation instructions are a type of combat orders which primarily affect the employment of signal communication troops and agencies. They are instructions issued for the technical control and coordination of signal agencies throughout the command. In general they are issued in advance of a contemplated operation. They may remain in force throughout the entire operation or cycle of operations, or they may be changed whenever required to insure secrecy or technical coordination. They are prepared by signal officers of divisions and higher headquarters and are issued to subordinate units in the name of the respective commander. Units smaller than the division have little occasion to prepare signal operation instructions. However, an independent force smaller than a division may find it advantageous to prepare certain items of signal operation instructions if it is to be engaged on a separate mission for any appreciable length of time.

b. The instructions are prepared as separate items so that only those items which apply to their particular duties may be issued to interested personnel. Each headquarters which issues items of signal operation instructions issues both an index and a distribution list, each as separate items.

(1) The index states the title of each item of signal operation instructions, the serial number of each item, the issuing headquarters when other than the headquarters issuing the index, the date and hour each item becomes effective or is to supersede a previous item when such is the case, and such other pertinent remarks as are essential. A new index with a new serial number is prepared and issued whenever a new item or a change is issued.

(2) Each item of signal operation instructions has a characteristic distribution which includes only those units or individuals concerned. This characteristic distribution, generally referred to as "Distribution S," is itself published and distributed as an item. It lists the number of copies of each item to be distributed to each unit and its subordinate units to include companies, troops, and batteries.

c. Each item covers a certain distinct phase of the activity concerned and is designated by a title descriptive of its contents and by a number which is changed serially for successive issues of that item. At the top of each item there appears the heading **SIGNAL OPERATION INSTRUCTIONS**. Following this is the title of the item and below this is the serial number of the item. Next, on the right, come the organization, place, date and hour signed, as for field orders. Below this appears a statement giving the time the item becomes effective when other than the hour signed. When applicable, the classification **SECRET**, **CONFIDENTIAL**, or **RESTRICTED** is noted as prescribed by AR 380-5. The body follows, giving in convenient form the technical instructions which are to be observed. Next appears below the body the signature and authentication as for field orders. The distribution, stated as "Distribution S," is noted after the authentication.

d. Examples of items of signal operation instructions showing form and examples of appropriate instructions included in the items bearing the titles used in the examples are given on pages 263 to 284, inclusive. Except for the items of index and Distribution S, appropriate titles for required items will be determined by the headquarters of issue. For example, it may be found expedient to combine certain in-

structions in one item which might result in a title as Identification Panel Code and Supplement to AGL-T1, etc.

■ 262. FORMS.—Signal forms and examples of some completed forms are based upon the general forms prescribed in Staff Officers' Field Manual and will be used as guides only by division signal communication units with such modifications as are demanded by the situation, size of the unit, and time available in each case. Check lists are furnished as a guide for preparing the necessary instructions.

Check list for

SIGNAL ESTIMATE OF THE SITUATION

1. **SIGNAL MISSION.**
2. **ENEMY SITUATION.**
 - a. Agencies which may affect own communication.
3. **OWN SITUATION.**
 - a. Decision of commander.
 - b. Location of own troops.
 - c. Probable movement of own troops including—
 - (1) Route.
 - (2) Time.
 - (3) Possible damage to wire circuits during movement.
 - d. Existing signal communication available including commercial circuits.
 - e. Signal communication troops.
 - (1) Strength, disposition, physical training, morale.
 - (2) Duties now engaged upon.
 - (3) Equipment and transportation.
 - f. General.
 - (1) Terrain.
 - (2) Roads and railroads.
 - (3) Weather.
 - (4) Personal characteristics of commander and staff.
4. **PLANS.**
 - a. Location of command posts and axis of signal communication.
 - b. Employment of agencies including—
 - (1) Message center.
 - (2) Messenger.
 - (3) Pigeon.
 - (4) Radio.
 - (5) Visual.
 - (6) Sound.
 - (7) Wire.
 - (8) Supply.
5. **DECISION.**—Based upon conclusions from above estimate.

SIGNAL COMMUNICATION

Check list for preparing

SIGNAL ANNEX TO FIELD ORDERS

1. Maps.
2. Information of enemy and own troops.
3. General plan for installation, operation, and maintenance of signal communication.
4. Instructions to Signal Corps troops to include—
 - a. Message centers and messengers.
 - b. Radio and visual.
 - c. Wire.
 - d. Any other agencies employed.
5. Instructions to Infantry and Field Artillery Brigade, etc., to include duties in 4 above.
6. Instructions applying to more than one unit.
7. Priority of signal communication troops on roads, location of signal dump, matters pertaining to signal supply, pigeons, storage batteries, etc.
8. Index to signal operation instructions.
9. Location of signal officer.

SIGNAL COMMUNICATION

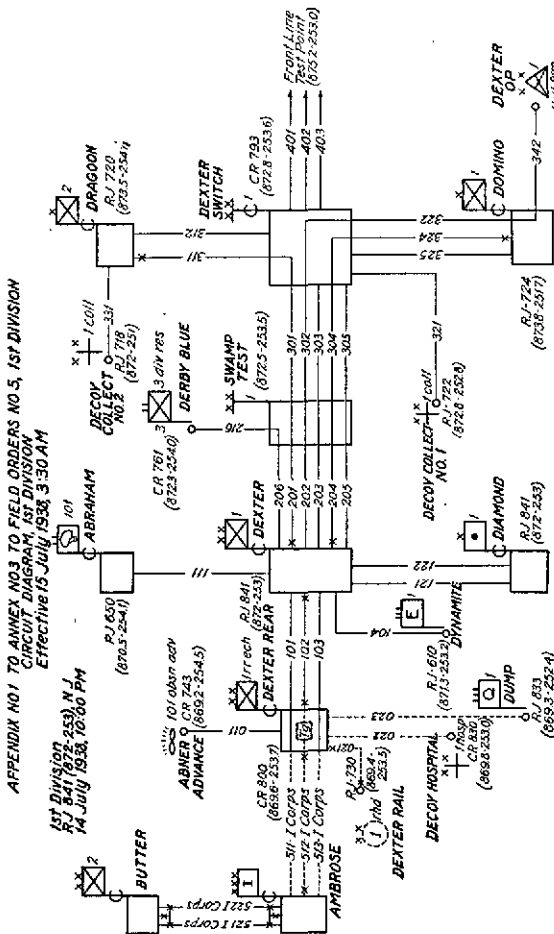
An example of a
CIRCUIT DIAGRAMPrepared for issue as an appendix to a signal annex to a
division field order

SIGNAL COMMUNICATION

Check list for
ORDER OF SIGNAL UNIT

1. Maps.
2. Information of enemy and own troops.
3. General plan of unit commander.
4. Detail orders for all sections of unit.
5. Reference to signal operation instruction.
6. Location of unit commander.

A form for a
SIGNAL UNIT JOURNAL
—— Journal ¹

Time ²		Serial No.	Time dated ³	Incidents, messages, orders, etc.	Disposition ⁴
In	Out				
				(Day and date)	

¹ The journal is the day book of the signal section or unit. It is usually not kept by signal units of organizations smaller than a division. It contains briefs of important written and oral messages received and sent and notations of periodic reports, orders, and similar matters that pertain directly to the section or unit. Copies of messages and other data pertaining to the section or unit and furnished by it for purposes of information of other sections or units are not entered in the journals. If any item is received or issued in oral form, the entry herein is detailed; if in document form, the entry may be a notation referring to a file or a brief synopsis of contents.

² Refers to time of receipt or sending in this office.

³ Refers to time information originated thus calling attention to age of the information.

⁴ The following symbols may be used: M=noted on situation map; S=standard distribution at CP; T=information furnished troops.

SIGNAL COMMUNICATION

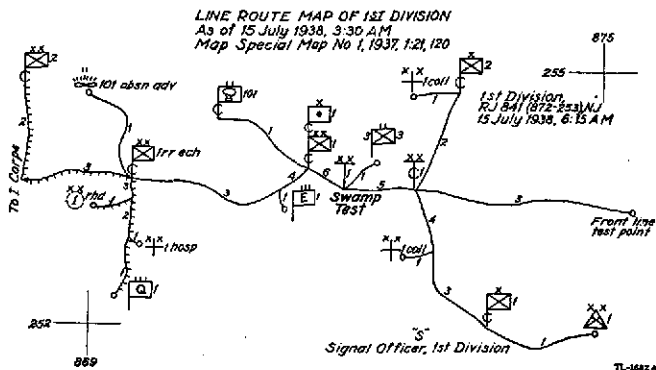
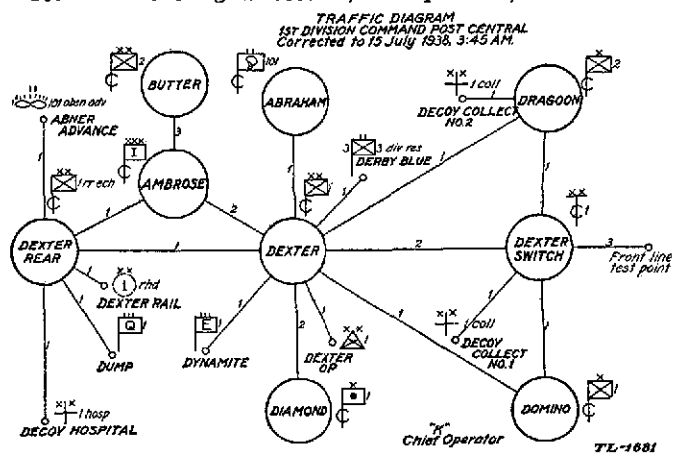
An example of a
LINE ROUTE MAPPrepared as a record for the Signal Section, Headquarters
1st DivisionAn example of a
TRAFFIC DIAGRAMPrepared for use at a telephone central and retained as a
record for the Signal Section, Headquarters, 1st Division

SIGNAL COMMUNICATION

An example of
SIGNAL OPERATION INSTRUCTIONS

RESTRICTED*

SIGNAL OPERATION INSTRUCTIONS

INDEX

NO. 6

1st Division,

GETTYSBURG, PA.

13 November 1938, 8:00 AM

Title of item	Serial No.	Remarks
GENERAL		
Index to Signal Operation Instructions.	6	Supersedes No. 5, 15 Nov, 12:01 a. m.
Distribution S for Signal Operations Instructions and Signal Annex.	2	
Index to Regulations and Orders on Signal Communication.	2	
CODES AND CIPHER KEYS		
Air-Ground Liaison Code (AGL) ¹	T-1	Issued by GHQ.
Fire Control Code (FCC) ¹	T-1	Issued by GHQ.
Supplement to (AGL-T1).....	2	Supersedes No. 1, 15 Nov, 12:01 a. m.
Supplement to (FCC-T1).....	2	Supersedes No. 1, 15 Nov, 12:01 a. m.
Identification Panel Code.....	2	Supersedes No. 1, 15 Nov, 12:01 a. m.
Cipher Keys for Cipher Device M-94.	6	Supersedes No. 5, 15 Nov, 12:01 a. m.
Division Field Code (DFC) ¹	T-1	Issued by GHQ.
Geographical Supplement to (DFC-T1).	6	Supersedes No. 5, 15 Nov, 12:01 a. m.
Map Coordinate Code ¹	2	Issued by Hq I Corps. Supersedes No. 1, 15 Nov, 12:01 a. m.
Pyrotechnic Code ¹	2	Issued by Hq First Army. Supersedes No. 1, 15 Nov, 12:01 a. m.
Telephone Directory.....	4	
RADIO COMMUNICATION		
Radio Frequencies.....	2	Supersedes No. 1, 15 Nov, 12:01 a. m.
Radio Call Signs ¹	3	Supersedes No. 2, 15 Nov, 12:01 a. m.
Radio Call Signs, I Corps ¹	4	Issued by Hq I Corps. Supersedes No. 3, 15 Nov, 12:01 a. m. (omitted).

¹ Distributed within this division by the division signal officer.

² Call signs for wire telegraph and visual stations, within this division, are the same as for radio stations.

NOTE.—The items listed in this index are already in effect unless otherwise stated in the column "Remarks."

RESTRICTED

*The word "RESTRICTED" used in this and other examples of signal operation instructions which follow is only an example of a classification and does not necessarily mean that those instructions should be so classified.

SIGNAL COMMUNICATION

RESTRICTED

By command of Major General A:
X,
Colonel, General Staff Corps,
Chief of Staff.

Official:

Y,
Lieutenant Colonel, General Staff Corps,
Assistant Chief of Staff, G-3.
Distribution S.

RESTRICTED

An example of
SIGNAL OPERATION INSTRUCTIONS, Continued

SIGNAL OPERATION INSTRUCTIONS

DISTRIBUTIONS

FOR SIGNAL OPERATION INSTRUCTIONS AND SIGNAL ANNEX

NO. 2

RESTRICTED

1st Division,
 CARLISLE, PA
 1 November 1938, 9:00 AM

Effective 2 November 1938, 12:01 AM

Organizations	Index, Sig Opn Instrns	"Distribution S"	Index, Regs, and Orders	Air-Ground Liaison Code (AGL)	Supplement, AGL	Fire Control Code (FCC)	Supplement, FCC	Identification Panel Code	Cipher Keys	Division Field Code (DFC)	Geog. Supplement (DFC)	Map Coordinate Code	Pyrotechnic Code	Telephone Directory	Radio Frequencies	Radio Call Signs	Radio Call Signs, I Corps	Sig Annex
Staff Officers, Div Hq.	21	21	21															5
Div Sig O	10	10	10	5	10	5	10	10	10	5	10	10	10	10	10	10	5	10
1st Sig Co	15	15	15	5	5	5	5	5	5	5	5	15	15	20	13	13	13	10
1st Tk Co	5	5	5															1
Ea Inf Brig Total	36	36	36	27	27	27	27	27	36	36	36	36	54	54	44	44	44	32
Ea Inf Brig Hq	4	4	4	3	3	3	3	3	4	4	4	4	4	4	4	4	4	2
Ea Inf Regt Total	10	16	16	12	12	12	12	12	16	16	16	16	25	25	19	19	19	13
Ea Inf Regt Hq	4	4	4	3	3	3	3	3	4	4	4	4	4	4	4	4	4	2
Ea Inf Bn Total	4	4	4	3	3	3	3	3	4	4	4	4	7	7	7	7	7	5
Ea Inf Bn Hq	4	4	4	3	3	3	3	3	4	4	4	4	4	4	4	4	4	3
Ea R Co													1	1				
FA Brig Total	90	90	90	83	83	83	83	83	83	83	87	87	105	64	68	68	68	2
1st FA Brig Hq	4	4	4	3	3	3	3	3	3	3	3	4	4	4	4	4	4	2
1st Am Tn	27	27	27	25	25	25	25	25	9	9	9	26	32	18	19	19	19	1
Ea FA Regt (75-mm) Total	27	32	32	30	30	30	30	30	12	12	12	31	37	22	26	26	26	1
Ea FA Regt (155-mm) Total	32	5	5	3	3	3	3	3	3	3	3	3	4	4	5	5	5	1
Ea FA Regt Hq	5	5	5	3	3	3	3	3	3	3	3	3	4	4	4	4	4	1
Ea FA Bn (75-mm) Total	11	11	11	11	11	11	11	11	3	3	3	3	11	14	6	6	6	1
Ea FA Bn (155-mm) Total	9	9	9	9	9	9	9	9	3	3	3	3	9	6	6	6	6	1
Ea FA Bn Hq Btry	9	9	9	9	9	9	9	9	3	3	3	3	9	6	6	6	6	1
Ea FA Firing Btry	3	3	3	3	3	3	3	3	3	3	3	3	3	3	3	3	3	1
1st Engrs Total	3	3	3	3	3	3	3	3	3	3	3	3	3	3	3	3	3	1
1st Engrs Hq	3	3	3	3	3	3	3	3	3	3	3	3	3	3	3	3	3	1
Ea Engr Bn	1	1	1	1	1	1	1	1	1	1	1	1	1	1	1	1	1	1
1st Med Regt																		
1st QM Regt																		
Division Reserve																		
Corps	1	1	1	(0)	1	(0)	1	1	1	(0)	(0)	(0)	(0)	1	1	1	(0)	1
Division (on right)	1	1	1	(0)	1	(0)	1	1	1	(0)	(0)	(0)	(0)	1	1	1	(0)	1
Division (on left)	1	1	1	(0)	1	(0)	1	1	1	(0)	(0)	(0)	(0)	1	1	1	(0)	1
Journal																		
TOTAL	222	223	222	150	162	160	162	162	137	120	128	210	290	252	209	209	18	37
Attached Troops																		
Sq Cav	2	2	2	2	2	2	2	2	2	2	2	4	5	2	3	3	3	1
Obsn Sq	3	3	3	3	3	3	3	3	3	3	3	3	3	3	3	3	3	1
Bn Sq	2	2	2	2	2	2	2	2	2	2	2	2	2	2	2	2	2	1
Det CA (AA)	3	3	3	3	3	3	3	3	3	3	3	3	3	3	3	3	3	1
GRAND TOTAL	232	232	232	175	187	175	187	187	140	123	131	238	315	264	220	220	26	41

¹ Items issued by higher headquarters are not redistributed to higher or adjacent headquarters or to the diary.

² Note that these numbers represent the totals of all copies to be distributed to the units above mentioned, but that these totals are not additions of the numbers appearing in their respective columns.

The 1st Division message center will furnish brigades and separate units the number of copies of signal operation instructions shown in the above tabulation. Brigades and separate units are responsible that the prescribed number of copies are furnished to their subordinate units.

By command of Major General A:
 X,
 Colonel, General Staff Corps,
 Chief of Staff.

Official:
 Y,
 Lieutenant Colonel, General Staff Corps,
 Assistant Chief of Staff, G-3.
 Distribution S.

RESTRICTED

SIGNAL COMMUNICATION

An example of

SIGNAL OPERATION INSTRUCTIONS, Continued

SIGNAL OPERATION INSTRUCTIONS

INDEX TO REGULATIONS AND ORDERS ON SIGNAL COMMUNICATION
NO. 21st Div,
CARLISLE, PA
1 Nov 1938, 9:00 AM

<i>Reference</i>	<i>Subject or Title</i>
Cir 9, 1st Div, 1938	Batteries, storage, care in use of
Cir 6, First Army, 1938	Code, map coordinate, use of
GO 5, 1st Div, 1938	Codes and ciphers, general use of
Cir 4, 1st Div, 1938	Messages, field, cautions in preparation of
Cir 5, I Corps, 1938	Messages, radio, strict compliance with code and cipher requirements for
Cir 18, 1st Div, 1938	Messenger service, normal, for 1st Division
Cir 7, 1st Div, 1938	Panels, use of
Cir 2, 1st Div, 1938	Telephone calls, limitations on demand for Urgent calls
Cir 8, I Corps, 1938	Wire, recovery of, in forward areas
Memo 9, First Army, 1938	Wire systems, field, methods of installing
	By command of Major General A: X, Colonel, General Staff Corps, Chief of Staff.

Official:

Y,

Lieutenant Colonel, General Staff Corps.

Assistant Chief of Staff, G-3.

Distribution S.

SIGNAL COMMUNICATION

An example of
SIGNAL OPERATION INSTRUCTIONS, Continued

SIGNAL OPERATION INSTRUCTIONS

SUPPLEMENT TO AGL-T

NO. 2

RESTRICTED

1st Division,
GETTYSBURG, PA
13 November 1938, 8:00 AM

Effective 15 November 1938, 12:01 AM

1. *Special meanings for supplement groups.*—The following special meanings are assigned to supplement groups of the Air-Ground Liaison Code, Training Edition No 1 (AGL-T1). They should be pasted in the spaces reserved for same in both the encoding and decoding sections of the code. No other meanings will be assigned to the supplement groups listed below.

				ENCODE		
<i>Code Group</i>				<i>Panel</i>	<i>Special Meaning</i>	
Y	oke	K	ing	U	nit	593 ARENDSVILLE
E	asy	J	ig	J	ig	201 BENDERSVILLE
S	ail	X	ray	J	ig	489 BLUE RIDGE SUMMIT
E	asy	X	ray	N	egat	213 BRIDGEFORT
Y	oke	T	are	P	rep	601 CARLISLE
B	aker	Y	oke	Y	oke	145 CARR HILL
X	ray	S	ail	P	rep	577 CASHTOWN
I	nter	K	ing	R	oger	271 CATOCTIN MOUNTAIN
R	oger	M	ike	P	rep	457 CHAMBERSBURG
E	asy	B	aker	Y	oke	194 CONEWAGO CREEK
K	ing	M	ike	R	oger	319 CUMBERLAND VALLEY
V	ictor	T	are	H	ypo	555 EMMITSBURG
T	are	N	egat	F	ox	504 FAIRFIELD
B	aker	K	ing	T	are	133 FAYETTEVILLE
Q	usen	S	ail	R	oger	439 GETTYSBURG
J	ig	X	ray	D	og	305 GETTYSBURG & HARRISBURG RR
B	aker	D	og	R	oger	127 MOUNT HOLLY SPRINGS
E	asy	S	ail	D	og	209 MUMMASBURG
Q	ueen	L	ove	P	rep	433 POWERS HILL
H	ypo	J	ig	R	ogcr	247 ROCK CREEK
F	ox	I	nter	R	oger	223 SABILLASVILLE
X	ray	Z	cd	R	oger	583 SEVEN STARS
M	ike	F	ox	X	ray	359 SHIPPENSBURG
H	ypo	B	aker	F	ox	240 SOUTH MOUNTAIN
X	ray	B	aker	J	ig	562 THURMONT
B	aker	M	ike	L	ove	135 WAYNESBORO
P	rep	K	ing	P	rep	409 WESTERN MARYLAND RR, B & H DIV
Y	oke	L	ove	D	og	594 YORK SPRINGS

RESTRICTED

SIGNAL COMMUNICATION

RESTRICTED

DECODE

	<i>Code Group</i>		<i>Panel</i>	<i>Special Meaning</i>
B	aker	D og	R oger	127 MOUNT HOLLY SPRINGS
B	aker	K ing	T are	133 FAYETTEVILLE
B	aker	M ike	L ove	135 WAYNESBORO
R	aker	Y oke	Y oke	145 CARR HILL
E	asy	B aker	Y oke	194 CONEWAGO CREEK
E	asy	J ig	J ig	201 BENDERSVILLE
E	asy	S ail	D og	209 MUMMASBURG
E	asy	X ray	N egat	213 BRIDGEPORT
F	ox	I nter	R oger	223 SABILLASVILLE
H	ypo	B aker	F ox	240 SOUTH MOUNTAIN
H	ypo	J ig	R oger	247 ROCK CREEK
I	nter	K ing	R oger	271 CATOCTIN MOUNTAIN
J	ig	X ray	D og	305 GETTYSBURG & HARRISBURG RR
K	ing	M ike	R oger	319 CUMBERLAND VALLEY
M	ike	F ox	X ray	359 SHIPPENSBURG
P	rep	K ing	P rep	409 WESTERN MARYLAND RR, B & H DIV
Q	ueen	L ove	P rep	433 POWERS HILL
Q	ueen	S ail	R oger	439 GETTYSBURG
R	oger	M ike	P rep	457 CHAMBERSBURG
S	ail	X ray	J ig	489 BLUE RIDGE SUMMIT
T	are	N egat	F ox	504 FAIRFIELD
V	ictor	T are	H ypo	555 EMMITSBURG
X	ray	B aker	J ig	562 THURMONT
X	ray	S ail	P rep	577 CASHTOWN
X	ray	Z ed	R oger	583 SEVEN STARS
Y	oke	K ing	U nit	593 ARENDTSTVILLE
Y	oke	L ove	D og	594 YORK SPRINGS
Y	oke	T are	P rep	601 CARLISLE

2. Map coordinates appearing in messages encoded in the Air-Ground Liaison Code will be encoded in the map coordinate code listed in the current Index to Signal Operation Instructions of this division.

By command of Major General A:

X,

Colonel, General Staff Corps,
Chief of Staff.

Official:

Y,

Lieutenant Colonel, General Staff Corps,
Assistant Chief of Staff, G-3.

Distribution S.

RESTRICTED

SIGNAL COMMUNICATION

An example of

SIGNAL OPERATION INSTRUCTIONS, Continued

SIGNAL OPERATION INSTRUCTIONS

SUPPLEMENT TO FCC-T1

NO. 2

RESTRICTED

1st Division,
GETTYSBURG, PA
13 November 1938, 8:00 AM

Effective 15 November 1938, 12:01 AM

1. SPECIAL MEANINGS FOR SUPPLEMENT GROUPS.—The following special meanings are assigned to supplement groups of Fire Control Code, Training Edition No. 1 (FCC-T1). They should be entered on the code card, in pencil. No other meanings will be assigned to the supplement code groups listed below.

	Code Group		Panel	Special Meaning	
Z	ed	A	firm	079	Adjust (will adjust) on head of column
Z	ed	B	aker	080	Adjust (will adjust) on leading assault wave
Z	ed	C	ast	081	Adjust (will adjust) on rear target
Z	ed	E	asy	082	Check target location
Z	ed	F	ox	083	CONEWAGO CREEK
Z	ed	G	orge	084	Describe target
Z	ed	H	ypo	085	Fly (will fly) gun-target line
Z	ed	J	nter	086	GERMANTOWN
Z	ed	J	ig	087	Hostile plane near you
Z	ed	K	ing	088	LOCUST GROVE SCHOOL
Z	ed	L	ove	089	NORTHERN CENTRAL RR
Z	ed	M	ike	090	PLUM CREEK
Z	ed	N	egat	091	TWO TAVERNS
Z	ed	P	rep	092	WHITEHALL
Z	ed	Q	ueen	093	YORK ELECTRIC RR
Z	ed	R	oger	094	Zoom (will zoom) over target

By command of Major General A:

X,

Colonel, General Staff Corps,
Chief of Staff.

Official:

Y,

Lieutenant Colonel, General Staff Corps,
Assistant Chief of Staff, G-3.

Distribution S.

RESTRICTED

SIGNAL COMMUNICATION

An example of
SIGNAL OPERATION INSTRUCTIONS, Continued

SIGNAL OPERATION INSTRUCTIONS

IDENTIFICATION PANEL CODE

NO. 2

RESTRICTED

1st Division,

GETTYSBURG, PA

13 November 1938, 8:00 AM

Effective 15 November 1938, 12:01 AM

Except for such extracts as may be required, these instructions will not be taken forward of command posts of front line battalions.

ENCODING SECTION

Unit	Groups			
	November			Dec.
	15-17	18-21	22-25	26-4
1st Division.....	014	210	353	013
1st Brigade.....	354	006	008	200
1st Infantry.....	355	012	014	220
1st Bn 1st Inf.....	015	003	184	356
2d Bn 1st Inf.....	353	359	013	004
3d Bn 1st Inf.....	004	588	585	300
2d Infantry.....	584	200	589	590
1st Bn 2d Inf.....	184	013	360	015
2d Bn 2d Inf.....	588	220	003	210
3d Bn 2d Inf.....	585	004	210	359
2d Brigade.....	356	353	584	003
3d Infantry.....	003	184	588	355
1st Bn 3d Inf.....	220	009	354	014
2d Bn 3d Inf.....	582	354	586	584
3d Bn 3d Inf.....	583	586	197	358
4th Infantry.....	160	589	356	585
1st Bn 4th Inf.....	210	015	160	008
2d Bn 4th Inf.....	586	361	583	583
3d Bn 4th Inf.....	009	583	220	361
1st FA Brig.....	361	007	359	160
1st FA.....	360	358	200	006
1st Bn 1st FA.....	008	356	007	353
2d Bn 1st FA.....	200	164	361	588
2d FA.....	012	582	355	354
1st Bn 2d FA.....	358	008	006	184
2d Bn 2d FA.....	197	584	015	007
3d FA.....	013	586	358	582
1st Bn 3d FA.....	359	360	009	197
2d Bn 3d FA.....	006	355	012	009
3d Bn 3d FA.....	580	197	582	012
Sq..... Cav.....	007	014	004	586

RESTRICTED

SIGNAL COMMUNICATION

RESTRICTED
DECODING SECTION

Group	November				Dec.	
	15-17	18-21	Group	22-25		Group
	Unit	Unit	Unit	Unit	Unit	Unit
003	3d Infantry	1st Bn 1st Inf.	003	2d Bn 2d Inf.	003	2d Brigade.
004	3d Bn 1st Inf.	3d Bn 2d Inf.	004	Sq. Cav.	004	2d Bn 1st Inf.
006	2d Bn 3d FA.	1st Brigade.	006	1st Bn 2d FA.	006	1st FA.
007	Sq. Cav.	1st FA Brig.	007	1st Bn 1st FA.	007	2d Bn 2d FA.
008	1st Bn 1st FA.	1st Bn 2d FA.	008	1st Brigade.	008	1st Bn 4th Inf.
009	3d Bn 4th Inf.	1st Bn 3d Inf.	009	1st Bn 3d FA.	009	2d Bn 3d FA.
012	2d FA.	1st Infantry.	012	2d Bn 3d FA.	012	3d Bn 3d FA.
013	3d FA.	1st Bn 2d Inf.	013	2d Bn 1st Inf.	013	1st Division.
014	1st Division.	Sq. Cav.	014	1st Infantry.	014	1st Bn 3d Inf.
015	1st Bn 1st Inf.	1st Bn 4th Inf.	015	2d Bn 2d FA.	015	1st Bn 2d Inf.
160	4th Infantry	2d Bn 1st FA.	160	1st Bn 4th Inf.	160	1st FA Brig.
184	1st Bn 2d Inf.	3d Infantry.	184	1st Bn 1st Inf.	184	1st Bn 2d FA.
197	2d Bn 2d FA.	3d Bn 3d FA.	197	3d Bn 3d Inf.	197	1st Bn 3d FA.
200	2d Bn 1st FA.	2d Infantry.	200	1st FA.	200	1st Brigade.
210	1st Bn 4th Inf.	1st Division.	210	3d Bn 2d Inf.	210	2d Bn 2d Inf.
220	1st Bn 3d Inf.	2d Bn 2d Inf.	220	2d Bn 2d Inf.	220	1st Infantry.
353	2d Bn 1st Inf.	2d Brigade.	353	3d Bn 4th Inf.	353	1st Bn 1st FA.
354	1st Brigade.	2d Bn 3d Inf.	354	1st Division.	354	2d FA.
355	1st Infantry.	2d Bn 3d FA.	355	1st Bn 3d Inf.	355	3d Infantry.
356	2d Brigade.	2d Bn 3d FA.	356	2d FA.	356	1st Bn 1st Inf.
358	1st Bn 2d FA.	1st Bn 1st FA.	358	4th Infantry.	358	1st Bn 1st Inf.
359	1st Bn 3d FA.	1st FA.	359	3d FA.	359	3d Bn 3d Inf.
360	1st FA.	2d Bn 1st Inf.	360	1st FA Brig.	360	3d Bn 2d Inf.
361	1st FA Brig.	1st Bn 3d FA.	361	1st Bn 2d Inf.	361	3d Bn 1st Inf.
582	2d Bn 3d Inf.	2d Bn 4th Inf.	582	2d Bn 1st FA.	361	3d Bn 4th Inf.
583	3d Bn 3d Inf.	2d FA.	582	3d Bn 3d FA.	582	3d FA.
		3d Bn 4th Inf.	583	2d Bn 4th Inf.	583	2d Bn 4th Inf.

SIGNAL COMMUNICATION

584	2d Infantry.....	584	2d Bn 2d F.A.....	584	2d Brigade.....	584	2d Bn 3d Inf.
585	3d Bn 2d Inf.....	585	3d F.A.....	585	3d Bn 1st Inf.....	585	4th Infantry.
586	2d Bn 4th Inf.....	586	3d Bn 3d Inf.....	586	2d Bn 3d Inf.....	586Sq....Cav.
588	2d Bn 2d Inf.....	588	3d Bn 1st Inf.....	588	3d Infantry.....	588	2d Bn 1st F.A.
589	3d Bn 3d F.A.....	589	4th Infantry.....	589	2d Infantry.....	590	2d Infantry.

Identification panel code groups will be assigned by this headquarters to other units when required.

By command of Major General A:

X,

Colonel, General Staff Corps,
Chief of Staff.

Official:

Y,

Lieutenant Colonel, General Staff Corps,
Assistant Chief of Staff, G-3.
Distribution S.

RESTRICTED

SIGNAL COMMUNICATION

An example of
SIGNAL OPERATION INSTRUCTIONS, Continued

SIGNAL OPERATIONS INSTRUCTIONS
CIPHER KEYS FOR CIPHER DEVICE M-94

NO. 6

RESTRICTED

1st Division,
GETTYSBURG, PA.,
13 November, 1938, 8:00 AM

1. These signal operation instructions will not be taken in advance of the command post of front line battalions.

2. The following key phrases apply for use in this division with the cipher device M-94, during the periods stated. To eliminate error on the part of code clerks, the disk arrangement has been worked out and is shown in the third line for each period. The provisions of Chapter 2, Section VI, FM 24-5, will govern in the use of the cipher device M-94.

From midnight 14/15 November to midnight 15/16 November
1-2-3-4-5-6-7-8-9-10-11-12-13-14-15-16-17-18-19-20-21-22-23-24-25
I T C A N B E D O N E A G A I N I T C A N B E D O
15-24-7-1-18-5-11-9-22-19-12-2-14-3-16-20-17-25-8-4-21-6-13-10-23

From midnight 15/16 November to midnight 16/17 November
1-2-3-4-5-6-7-8-9-10-11-12-13-14-15-16-17-18-19-20-21-22-23-24-25
C O M E A N D G E T I T N O W C O M E A N D G E T
3-19-14-7-1-18-5-11-8-22-13-23-17-20-25-4-21-15-9-2-18-9-12-10-24

From midnight 16/17 November to midnight 17/18 November
1-2-3-4-5-6-7-8-9-10-11-12-13-14-15-16-17-18-19-20-21-22-23-24-25
G E N E R A L E L E C T R I C G E N E R A L E L E
13-5-20-6-22-1-16-7-17-5-3-25-23-15-4-14-9-21-10-24-2-18-11-19-12

From midnight 17/18 November to midnight 18/19 November
1-2-3-4-5-6-7-8-9-10-11-12-13-14-15-16-17-18-19-20-21-22-23-24-25
R O C K Y M O U N T A I N G O A T R O C K Y M O U
18-13-3-7-24-9-14-22-11-20-1-6-12-5-15-2-21-19-16-4-8-25-10-17-23

From midnight 18/19 November to midnight 19/20 November
1-2-3-4-5-6-7-8-9-10-11-12-13-14-15-16-17-18-19-20-21-22-23-24-25
R E M E M B E R W A S H I N G T O N R E M E M B E
20-4-13-5-14-2-6-21-25-1-23-11-12-17-10-24-19-18-22-7-15-8-16-3-9

RESTRICTED

SIGNAL COMMUNICATION

RESTRICTED

By command of Major General A:

X,

Colonel, General Staff Corps,
Chief of Staff.

Official:

Y,

Lieutenant Colonel, General Staff Corps,
Assistant Chief of Staff, G-3.
Distribution S.

RESTRICTED

SIGNAL COMMUNICATION

An example of
SIGNAL OPERATION INSTRUCTIONS, Continued

SIGNAL OPERATION INSTRUCTIONS
GEOGRAPHICAL SUPPLEMENT TO DFC-T1

NO. 6

RESTRICTED

1st Division,
GETTYSBURG, PA
13 November 1938, 8:00 AM

Effective 15 November 1938, 12:01 AM

ENCODE

NAVB----ABBOTTSTOWN
LAHO----ALLOWAY CREEK
UPBZ----BALTIMORE—GETTYSBURG TURNPIKE
JEMX----BEAVER DAM CREEK
YWML----BIGLERVILLE
KELI----BRUSH RUN
DEDR----CARLISLE ROAD
PICL----CATOCTIN MOUNTAIN
LAXE----CHAMBERSBURG PIKE
XOWS----CONEWAGO CREEK
RUXL----EMMITSBURG
UDXO----EMMITSBURG—TANEYTOWN ROAD
YTAK----GETTYSBURG
OAGZ----GETTYSBURG—HARRISBURG RR
EWEA----GETTYSBURG—TANEYTOWN ROAD
EFNB----HAGERSTOWN ROAD
UDFX----HANOVER
GASO----LITTLES RUN
KIBA----LITTLESTOWN
AKWB----LOW DUTCH ROAD
TOZX----MARSH CREEK
ACKY----MCSHERRYSTOWN
UNOL----MIDDLE CREEK
MAAU----MONOCACY RIVER

RESTRICTED

SIGNAL COMMUNICATION

RESTRICTED

ENCODE—continued

AKZE____PIGEON HILLS
 BAFS____PLUM CREEK
 AJME____ROCK CREEK
 GIKL____SOUTH BRANCH CONEWAGO CREEK
 JOBR____SOUTH MOUNTAIN
 BYAL____STATE HIGHWAY NO. 231
 GADA____SWIFT RUN
 ALBU____TANEYTOWN
 AERT____WAYNESBORO TURNPIKE
 IBRA____WESTERN MARYLAND RR
 COLS____WHITE RUN
 MASL____WILLOUGHBY RUN
 ZARE____WOLF HILL
 YXOB____WOLF RUN
 TUMA____YORK ROAD

DECODE

ACXY____MCSHERRYSTOWN
 AERT____WAYNESBORO TURNPIKE
 AJME____ROCK CREEK
 AKWB____LOW DUTCH ROAD
 AKZE____PIGEON HILLS
 ALBU____TANEYTOWN
 BAFS____PLUM CREEK
 BYAL____STATE HIGHWAY NO. 231
 COLS____WHITE RUN
 DEDR____CARLISLE ROAD
 EFNB____HAGERSTOWN ROAD
 EWEA____GETTYSBURG—TANEYTOWN ROAD
 GADA____SWIFT RUN
 GASO____LITTLES RUN
 GIKL____SOUTH BRANCH CONEWAGO CREEK
 IBRA____WESTERN MARYLAND RR
 JEMX____BEAVER DAM CREEK
 JOBR____SOUTH MOUNTAIN
 KELI____BRUSH RUN
 KIBA____LITTLESTOWN

RESTRICTED

SIGNAL COMMUNICATION

RESTRICTED

DECODE—continued

LAHO____ALLOWAY CREEK
LAXE____CHAMBERSBURG PIKE
MAAU____MONOCACY RIVER
MASL____WILLOUGHBY RUN
NAVB____ABBOTTSTOWN
OAGZ____GETTYSBURG—HARRISBURG RR
PICL____CATOCTIN MOUNTAIN
RUXL____EMMITSBURG
TOZX____MARSH CREEK
TUMA____YORK ROAD
UDFX____HANOVER
UDXO____EMMITSBURG—TANEYTOWN ROAD
UNOL____MIDDLE CREEK
UPBZ____BALTIMORE—GETTYSBURG TURNPIKE
XOWS____CONEWAGO CREEK
YTAK____GETTYSBURG
YWML____BIGLERVILLE
YXOB____WOLF RUN
ZARE____WOLF HILL

By command of Major General A:
X,
Colonel, General Staff Corps,
Chief of Staff.

Official:

Y,

Lieutenant Colonel, General Staff Corps,
Assistant Chief of Staff, G-3.

Distribution S.

RESTRICTED

SIGNAL COMMUNICATION

An example of
SIGNAL OPERATION INSTRUCTIONS, Continued

RESTRICTED

SIGNAL OPERATION INSTRUCTIONS

MAP COORDINATE CODE

NO. 2

I Corps,

CARLISLE, PA

10 November 1938, 12:45 PM

Effective 15 November 1938, 12:01 AM

1. This map coordinate code is for use with all gridded quadrangles of the U. S. Geological Survey, 1:62,500 for the area covered by the General Map, Gettysburg (1925), 1 inch=5 miles; and for all sheets of the Topographical Map, Gettysburg—Antietam (1925), 1:21,120.

2. Except for such extracts as may be required, this code will not be taken forward of command posts of front line battalions.

3. To *encode* 332.8-749.5—

a. For 332.8, locate 332 in the X coordinate table and write the letters at the head of the column and at the side of the line in which 332 appears in that order, followed by the decimal 8, as: PG8.

b. For 749.5, proceeding as in a above in the Y coordinate table, write: WF5.

c. Using any authorized code, substitute for PG8WF5 the six code groups corresponding to those letters and numerals. This is not necessary in the Fire-Control Code or in local prearranged codes.

4. Having decoded a message and obtained KL4DR7, to *decode* it further—

a. Find in the X coordinate table the number in column K in the line opposite L, and add 4 as the decimal: 446.4, which is the X coordinate.

RESTRICTED

SIGNAL COMMUNICATION

RESTRICTED

b. Find in the Y coordinate table the number in column **D** in the line opposite **R**, and add 7 as the decimal: 713.7 which is the Y coordinate.

RESTRICTED

RESTRICTED

ENCODING CHART

(To be used when marking maps)

Code Letter	X Coordinates								Code Letter	{ 25000 yd Square Indicator }	Code Letter	Y Coordinates								Code Letter
	R	J	P	C	L	Q	K	G				U	D	W	A	Q	B	F		
H	275	300	325	350	375	400	425	450	H	{ 25000 yd Square Indicator }	J	675	700	725	750	775	800	825	J	
C	276	301	326	351	376	401	426	451	C		N	676	701	726	751	776	801	826	C	
R	277	302	327	352	377	402	427	452	R		O	677	702	727	752	777	802	827	R	
F	278	303	328	353	378	403	428	453	F		Y	678	703	728	753	778	803	828	F	
A	279	304	329	354	379	404	429	454	A		L	679	704	729	754	779	804	829	A	
T	280	305	330	355	380	405	430	455	T		P	680	705	730	755	780	805	830	T	
Q	281	306	331	356	381	406	431	456	Q		D	681	706	731	756	781	806	831	Q	
G	282	307	332	357	382	407	432	457	G		B	682	707	732	757	782	807	832	G	
B	283	308	333	358	383	408	433	458	B		Q	683	708	733	758	783	808	833	B	
O	284	309	334	359	384	409	434	459	O		K	684	709	734	759	784	809	834	O	
M	285	310	335	360	385	410	435	460	M		Y	685	710	735	760	785	810	835	M	
K	286	311	336	361	386	411	436	461	K		I	686	711	736	761	786	811	836	K	
Z	287	312	337	362	387	412	437	462	Z		H	687	712	737	762	787	812	837	Z	
F	288	313	338	363	388	413	438	463	F		R	688	713	738	763	788	813	838	F	
U	289	314	339	364	389	414	439	464	U		W	689	714	739	764	789	814	839	U	
J	290	315	340	365	390	415	440	465	J		X	690	715	740	765	790	815	840	J	
D	291	316	341	366	391	416	441	466	D		C	691	716	741	766	791	816	841	D	
N	292	317	342	367	392	417	442	467	N		M	692	717	742	767	792	817	842	N	
V	293	318	343	368	393	418	443	468	V		T	693	718	743	768	793	818	843	V	
W	294	319	344	369	394	419	444	469	W		G	694	719	744	769	794	819	844	W	
S	295	320	345	370	395	420	445	470	S		U	695	720	745	770	795	820	845	S	
L	296	321	346	371	396	421	446	471	L		A	696	721	746	771	796	821	846	L	
Y	297	322	347	372	397	422	447	472	Y		Z	697	722	747	772	797	822	847	Y	
I	298	323	348	373	398	423	448	473	I		S	698	723	748	773	798	823	848	I	
X	299	324	349	374	399	424	449	474	X		F	699	724	749	774	799	824	849	X	
	B	J	P	C	L	Q	K	G			{ 25000 yd Square Indicator }		U	D	W	A	Q	B	F	

DECODING CHART

Code Letter	X Coordinates								Code Letter	{ 25000 yd Square Indicator }	Code Letter	Y Coordinates								Code Letter
	C	G	J	K	L	P	Q	R				A	B	D	F	Q	U	W		
A	354	454	304	429	379	329	404	279	A	{ 25000 yd Square Indicator }	A	771	821	721	846	796	696	746	A	
B	358	458	308	433	383	333	408	283	B		B	757	807	707	832	782	682	732	B	
C	351	451	301	426	376	326	401	276	C		C	766	816	716	841	791	691	741	C	
D	366	466	316	441	391	341	416	291	D		D	756	806	706	831	781	681	731	D	
F	363	463	313	438	388	338	413	288	F		F	774	824	724	849	799	699	749	F	
G	357	457	307	432	382	332	407	282	G		G	769	819	719	844	794	694	744	G	
H	360	460	300	425	375	325	400	275	H		H	762	812	712	837	787	687	737	H	
I	373	473	323	448	398	348	423	298	I		I	761	811	711	836	786	686	736	I	
J	366	466	316	440	390	340	415	290	J		J	750	800	700	825	775	675	725	J	
K	361	461	311	436	386	336	411	286	K		K	759	809	709	834	784	684	734	K	
L	371	471	321	446	396	346	421	296	L		L	754	804	704	829	779	679	729	L	
M	360	460	310	435	385	335	410	285	M		M	767	817	717	842	792	692	742	M	
N	367	467	317	442	392	342	417	292	N		N	751	801	701	826	776	676	726	N	
O	369	469	309	434	384	334	409	284	O		O	752	802	702	827	777	677	727	O	
P	353	453	303	428	378	328	403	278	P		P	755	805	705	830	780	680	730	P	
Q	356	456	306	431	381	331	406	281	Q		Q	758	808	708	833	783	683	733	Q	
R	352	452	302	427	377	327	402	277	R		R	763	813	713	838	788	688	738	R	
S	370	470	320	445	395	345	420	295	S		S	773	823	723	848	798	698	748	S	
T	355	455	305	430	380	330	405	280	T		T	768	818	718	843	793	693	743	T	
U	364	464	314	439	389	339	414	289	U		U	770	820	720	845	795	695	745	U	
V	368	468	318	443	393	343	418	293	V		V	753	803	703	828	778	678	728	V	
W	369	469	319	444	394	344	419	294	W		W	764	814	714	839	789	689	739	W	
X	374	474	324	449	399	349	424	299	X		X	765	815	715	840	790	690	740	X	
Y	372	472	322	447	397	347	422	297	Y		Y	760	810	710	835	785	685	735	Y	
Z	362	462	312	437	387	337	412	287	Z		Z	772	822	722	847	797	697	747	Z	
	C	G	J	K	L	P	Q	R			{ 25000 yd Square Indicator }		A	B	D	F	Q	U	W	

By command of Lieutenant General A:
X,
 Brigadier General, General Staff Corps,
 Chief of Staff.

Official:
Y,
 Colonel, General Staff Corps,
 Assistant Chief of Staff, G-3.
 Distribution S.

SIGNAL COMMUNICATION

An example of
SIGNAL OPERATION INSTRUCTIONS, Continued

RESTRICTED

SIGNAL OPERATION INSTRUCTIONS

PYROTECHNIC CODE

NO. 2

First Army,

HARRISBURG, PA

10 November 1938, 11:30 AM

Effective 15 November 1938, 12:01 AM

<i>Signal</i>	<i>Meaning</i>
Cartridge, Very, 10-gage, red-----	Artillery is firing short.
Cartridge, Very, 10-gage, green----	Lift barrage.
Signal, ground, red star, cluster M6 -----	Fire barrage.
Signal, ground, red chain, para- chute M7-----	Objective taken.
Signal, aircraft, red star, parachute M11 -----	Display panels (identifi- cation or marking).
Cartridge, Very, 10-gage, white---	Understood.
Signal, ground, white star, para- chute M5-----	Understood.
Signal, aircraft, white star, para- chute M10-----	Understood.

By command of General A:

X,

Major General, General Staff Corps,
Chief of Staff.

Official:

Y,

Colonel, General Staff Corps,
Assistant Chief of Staff, G-3.

Distribution S.

RESTRICTED

SIGNAL COMMUNICATION

An example of
SIGNAL OPERATION INSTRUCTIONS, Continued

SIGNAL OPERATION INSTRUCTIONS

TELEPHONE DIRECTORY

NO. 4

1st Division,
CARLISLE, PA
1 November 1938, 9:00 AM

Effective 4 November 1938, 12:01 AM

1. TELEPHONE DIRECTORY NAMES — ORGANIZATION HEAD-
QUARTERS.

<i>Unit</i>	<i>Name</i>
_____Corps.....	_____
_____Div (on right).....	_____
_____Div (on left).....	_____
1st Div.....	DEXTER
Sp Trs 1st Div.....	DART
1st Sig Co.....	DIAGRAM
1st Tk Co.....	DEMOLISH
1st Ord Co.....	DRUM
1st MP Co.....	DARKNESS
1st Brig.....	DOMINO
1st Inf.....	DANDY
2d Inf.....	DELTA
2d Brig.....	DRAGOON
3d Inf.....	DERBY
4th Inf.....	DRAKE
1st FA Brig.....	DIAMOND
1st FA.....	DUPLEX
2d FA.....	DELEGATE
3d FA.....	DONKEY
1st Am Tn.....	DANGER
1st Engrs.....	DYNAMITE
1st Med Regt.....	DECOY
1st QM Regt.....	DUMP

SIGNAL COMMUNICATION

Attached Troops

_____ Obsn Sq _____
 _____ Bln Sq _____
 _____ Sq _____ Cav _____
 Det _____ CA (A-A) _____

RED, WHITE or BLUE added to a regimental name, gives the name of its 1st, 2d or 3d Battalion, respectively. Example: DERBY RED is the name of the 1st Battalion, 3d Infantry.

The rear echelon, observation post, advance command post, railhead or other distant establishment pertaining to a headquarters, takes the name of the headquarters followed by an appropriate single word or generally used spoken abbreviation such as Rear, OP, Advance, Rail, Switch, *Collect No. 1*, etc. Stations of the Medical Regiment take the basic name of that regiment, as "Decoy Hospital", or "Decoy Collect No 1".

Attached organizations retain the telephone names assigned to them by their parent organization.

2. TELEPHONE DIRECTORY NUMBERS—OFFICERS AND OFFICES.

Code No. Title

- 1___ G-1 or S-1
- 2___ G-2 or S-2
- 3___ G-3 or S-3
- 4___ G-4 or S-4
- 5___ Chief of staff or executive officer
- 6___ Commanding officer
- 7___ Adjutant (division and higher units)
- 8___ Ordnance officer
- 9___ Inspector
- 10___ Signal or communication officer
- 11___ Message center
- 13___ Aide-de-camp
- 14___ Air officer
- 15___ Engineer officer
- 16___ Surgeon or medical officer
- 17___ Judge Advocate
- 18___ Finance officer
- 19___ Chaplain
- 20___ Postal officer

SIGNAL COMMUNICATION

<i>Code No.</i>	<i>Title</i>
21---	Quartermaster (not supply officer)
22---	Chief of artillery or artillery officer
23---	Chemical or gas officer
24---	Liaison officer
25---	Munitions officer
26---	Pigeon loft
27---	Provost marshal, commanding officer, special troops, or headquarters commandant
28---	Radio station
29---	Reconnaissance officer
30---	Telegraph office
31---	Telephone wire chief or trouble chief
32---	Veterinarian
33---	Public telephone

3. TELEPHONE DIRECTORY TO BE ATTACHED TO TELEPHONES AND SWITCHBOARDS.—Labels bearing the telephone directory names and numbers applicable to this division, will be prepared by these headquarters and issued in quantities sufficient for all field telephones and switchboards in service. They will be attached to each such telephone and switchboard.

By command of Major General A:

X,

Colonel, General Staff Corps,
Chief of Staff.

Official:

Y,

Lieutenant Colonel, General Staff Corps,
Assistant Chief of Staff, G-3.

Distribution S.

SIGNAL COMMUNICATION

RESTRICTED

SIGNAL OPERATION INSTRUCTIONS

RADIO FREQUENCIES

NO. 2

1st Division

GETTYSBURG, PA

13 November 1938, 8:00 AM

Effective 15 November 1938, 12:01 AM

1. Except for such extracts as may be required, these instructions will not be taken forward of command posts of front line battalions.

2. The following frequencies and only the following, will be used by the units of this division unless otherwise authorized by these headquarters.

*Frequencies
in kilocycles*

Nets

350_____	I Corps
2660_____	1st Division (Command)
3200_____	1st Division Headquarters Air-Ground
4100_____	1st Brigade
4000_____	1st Infantry
4200_____	2d Infantry
4300_____	2d Brigade
4050_____	3d Infantry
4150_____	4th Infantry

See paragraph 3c for assignment of frequency channels for SCR-195 sets.

4600_____	1st Field Artillery Brigade (Command)
3100_____	1st Field Artillery Brigade Air-Ground
3300_____	Artillery plane—Artillery ground station
3400_____	Artillery plane—Artillery ground station
3500_____	Artillery plane—Artillery ground station
4800_____	1st Field Artillery
4400_____	2d Field Artillery

See paragraph 3b for assignment of frequency channels of SCR-194 sets.

RESTRICTED

SIGNAL COMMUNICATION

RESTRICTED

*Frequencies
in kilocycles*

	<i>Nets</i>
5000-----	3d Field Artillery
4900-----	1st Bn 3d F A Observation
4450-----	2d Bn 3d F A Observation
4650-----	3d Bn F A Observation
2400-----	1st Tank Company
2420-----	1st Platoon 1st Tank Company
2440-----	2d Platoon 1st Tank Company
2460-----	3d Platoon 1st Tank Company
3000-----	----- Observation Squadron

3. FREQUENCY CHANNELS SCR-194 AND SCR-195.—*a.* The channels prescribed below only will be used except by authority of this headquarters.

b. The following frequency channels SCR-194 are allotted to the field artillery units indicated for assignment by the respective regimental commanders:

<i>Channel numbers</i>	<i>Unit</i>
1-5 inclusive and	
21-25 inclusive (all Range A)-----	1st Field Artillery
41-45 inclusive and	
56-60 inclusive-----	2d Field Artillery

c. The following frequency channels SCR-195 are allotted to the infantry units indicated.

	<i>Channel numbers</i>	<i>Unit</i>
	19-----	1st Infantry
I	21-----	1st Bn 1st Infantry
	23-----	2d Bn 1st Infantry
	25-----	3d Bn 1st Infantry
	10-----	2d Infantry
	12-----	1st Bn 2d Infantry
	14-----	2d Bn 2d Infantry
	6-----	3d Bn 2d Infantry
	1-----	3d Infantry
	3-----	1st Bn 3d Infantry
	5-----	2d Bn 3d Infantry
	7-----	3d Bn 3d Infantry

RESTRICTED

An example of
SIGNAL OPERATION INSTRUCTIONS, Continued

SIGNAL OPERATION INSTRUCTIONS
RADIO CALL SIGNS

NO. 3

RESTRICTED

1st Division,
GETTYSBURG, PA
13 November 1938, 8:00 AM

Effective 15 November 1938, 12:01 AM

1. Except for such extracts as may be required, these instructions will not be taken forward of command posts of front line battalions.
2. The following call signs of radio stations and nets, and no others, will be used by the radio stations of this division during the periods of time specified.
3. These radio call signs will be used also for wire telegraph and visual stations.

Headquarters or net	November								Decem- ber
	15-17	18	19-21	22-23	24-25	26	27-28	29-1	2-4
1st Division Headquarters	GT	FU	XP	PO	PJ	HY	GK	MN	LG
1st Division Net (Command)	UB	MW	GA	JD	HJ	JD	VJ	XI	OC
1st Brigade Headquarters	UN	YF	YR	SP	YV	HB	SZ	OY	YO
1st Brigade Net	SX	CW	PG	LA	YB	HC	XS	YA	JD
1st Infantry Headquarters	LA	OZ	YA	HK	CT	HU	UF	HW	GB
1st Infantry Net	VW	HV	PH	UH	GW	GP	VO	PF	YT
1st Bn 1st Inf Headquarters	MS	LQ	VI	UF	MK	GX	GX	CD	GQ
2d Bn 1st Inf Headquarters	OA	MS	JI	HT	FK	GS	KK	FX	MG
3d Bn 1st Inf Headquarters	RK	PS	MQ	GO	PF	HF	YE	JZ	RY
2d Infantry Headquarters	DM	OU	DJ	BF	HD	HR	JH	MF	FB
2d Infantry Net	IC	XV	HG	VP	YF	HZ	JL	FU	GD
1st Bn 2d Inf Headquarters	LB	RH	UF	XV	RJ	HQ	YM	OA	OR
2d Bn 2d Inf Headquarters	HY	EK	OZ	LP	MG	JL	HV	RS	PB
3d Bn 2d Inf Headquarters	PN	MV	VQ	VH	PN	HK	JT	JS	SZ
2d Brigade Headquarters	MD	RC	LK	MV	CZ	HP	DC	JG	RN
2d Brigade Net	HO	FC	GU	OY	OG	HJ	CP	UC	FS
3d Infantry Headquarters	FY	DW	UA	CD	UG	JH	PD	JX	GC
3d Infantry Net	JG	GU	BQ	SO	ED	JF	RO	FL	LJ
1st Bn 3d Inf Headquarters	YV	VU	CB	MP	JV	HD	MF	HY	DR
2d Bn 3d Inf Headquarters	MQ	FQ	FR	UP	LK	GT	LD	CP	LP
3d Bn 3d Inf Headquarters	SE	DP	DW	XH	RH	HA	CA	OW	HZ
4th Infantry Headquarters	PX	YL	HO	YI	JD	HO	RL	CT	HQ
4th Infantry Net	YD	LP	YX	VJ	RP	HT	DQ	XT	OM
1st Bn 4th Inf Headquarters	DR	CX	YZ	HZ	RG	GO	LG	RY	GX
2d Bn 4th Inf Headquarters	JY	DL	DQ	JI	UX	CS	SF	UM	UX
3d Bn 4th Inf Headquarters	LR	JL	GV	YK	DQ	CZ	CF	YP	FC
1st FA Brig Headquarters	YJ	OQ	YC	ST	OZ	CD	HQ	YE	JY
1st FA Brig Net (Command)	VL	RZ	UT	JC	SC	DI	GC	YI	CS
1st FA Brig Air-Ground Net	SL	PI	VJ	MO	HS	DJ	SP	BP	MA
1st Field Artillery Headquarters	UK	UA	LB	RU	MS	DM	YM	VH	LU
1st Field Artillery Net	HF	GF	FD	DM	GC	DO	XO	YJ	PO
1st Bn 1st FA Headquarters	JB	SO	UW	VQ	LJ	DN	GA	LS	MB
2d Bn 1st FA Headquarters	FD	YG	GV	CT	XR	QA	LV	CS	LS
2d Field Artillery Headquarters	FW	MC	OX	EK	DM	FJ	HW	SC	VO
2d Field Artillery Net	GB	MZ	BJ	YP	CA	DY	MY	VO	XN
1st Bn 2d FA Headquarters	DY	PJ	YU	BA	DS	DW	UH	UK	JL
2d Bn 2d FA Headquarters	UL	DO	XQ	SB	JT	FV	XR	FT	RD
3d Field Artillery Headquarters	YX	XO	BG	OU	HX	YK	YT	GA	RI
3d Field Artillery Net	GF	YK	YB	OA	LG	FB	GP	DA	DY
1st Bn 3d FA Headquarters	YT	RL	LA	DU	FM	FD	OM	GQ	XS
2d Bn 3d FA Headquarters	HQ	MH	VU	MF	DJ	FP	VZ	CE	PN
3d Bn 3d FA Headquarters	CB	MP	FK	GS	CW	FL	XZ	JU	XO
1st Tank Company Headquarters	UI	FF	UM	FJ	EM	GC	CS	RQ	JU
1st Tank Company Net	LI	JO	PA	SY	FY	FC	VO	RD	GY
1st Plat 1st Tk Co Headquarters	MC	UZ	UV	PS	JY	FG	VU	YB	GL
2d Plat 1st Tk Co Headquarters	BS	RB	PC	UT	FK	FY	XM	YW	HL
3d Plat 1st Tk Co Headquarters	YW	HA	LW	BS	UB	FH	XW	VM	YI
Obsn Sq Headquarters	FX	GJ	YW	LS	SR	FW	JX	YN	OB
Obsn Sq Net	GD	DU	PV	OJ	PK	FX	HD	LK	LZ
Artillery plane	SH	DX	SB	DI	LT	GF	CR	RX	MP
Artillery plane	GY	JC	FV	VN	LD	FR	MU	FO	MI
Artillery plane	OP	RJ	FN	UY	YM	CU	FL	FS	FT
Artillery plane	FS	PG	PV	FJ	RU	DQ	SU	VW	DF
Division Headquarters plane	JR	BA	DM	DT	OA	OB	SC	ME	DF
Division Headquarters plane	YQ	FE	EE	DJ	FS	CB	HT	XM	LN
Division Headquarters plane	IN	YK	MN	LX	MQ	CV	HZ	LA	VM
Bn Sq Headquarters	YU	JA	SM	CB	UG	CT	LJ	OG	DY
Sq Cav Headquarters	YP	LU	SV	MH	VQ	DS	HS	OX	VK

By command of Major General A:

X,

Colonel, General Staff Corps,
Chief of Staff.

Official:

Y,

Lieutenant Colonel, General Staff Corps,
Assistant Chief of Staff, G-3.

Distribution S.

RESTRICTED

SIGNAL COMMUNICATION

RESTRICTED

<i>Channel numbers</i>	<i>Unit</i>
26-----	4th Infantry
28-----	1st Bn 4th Infantry
30-----	2d Bn 4th Infantry
32-----	3d Bn 4th Infantry

By command of Major General A:

X,

Colonel, General Staff Corps,
Chief of Staff.

Official:

Y,

Lieutenant Colonel, General Staff Corps,
Assistant Chief of Staff, G-3.

Distribution S.

RESTRICTED

INDEX

	Paragraph	Page
Abbreviations, message center.....	24	20
Agents:		
Employment	76	68
Qualifications	66	63
Batteries:		
Dry	243	241
Storage	253	247
Calls:		
Conference.....	180, 216	143, 217
Urgent.....	179, 217	142, 218
Centrals, telephone, installation.....	209	201
Charts, maps and diagrams, message center.....	23	19
Cipher device M-94:		
Cryptographing abbreviations, punctuation signs, and numbers.....	55	57
Cryptographing a message.....	54	52
Decryptographing a message.....	56	57
Description.....	51	48
Necessity for key.....	52	49
Precaution.....	57	59
Purpose and distribution.....	50	48
Setting the device.....	53	50
Ciphers, authorized military.....	48	46
Circuit diagram.....	173	135
Circuits:		
Bridging simplex around a switchboard.....	229	226
Mutual interference in simplex and phantom groups	214	208
Phantom	213	207
Simplex	212	206
Code, International Morse.....	127	105
Codes, authorized military.....	47	45
Codes and ciphers.....	100	87
Comparison.....	46	44
Rules for use.....	49	47
Colis, repeating.....	211, 244	203, 242
Communication officer:		
Duties	12	7
Staff and command functions.....	11	6
Conference calls.....	180, 216	143, 217
Cryptograms, use.....	43	40
Cryptography:		
Definitions.....	44	41
Safety afforded by.....	45	43

INDEX

	Paragraph	Page
Definitions:		
Cryptography	44	41
Message center	13	9
Radio communication	90	81
Signal communication	5	3
Sound communication	157	125
Wire communication	161	126
Field wire, types of	185	146
Testing on reels	242	240
Field wire lines	184	145
Circuit troubles	236	230
Construction and removal of test stations	199	181
Equipment used for testing	237	232
Loading of	206	193
Locating and clearing trouble	238	234
Maintenance	234	228
Operation of test stations	239	238
Overhead construction	201	185
Patching circuits at test stations	240	239
Patrolling	241	240
Procedure in laying	198	179
Railroad crossings	203	188
River crossings	204	188
Road crossings	202	187
Routine tests	235	228
Routing	196	178
Surface construction	200	184
Trench construction	205	190
Flags:		
Care	131	109
Equipment	130	108
Semaphore procedure	134	110
Semaphore transmission	135	110
Training	132	109
Use	133	109
Ground connection	228	226
International Morse Code	127	105
Instructions, signal operation	261	255
Lamps:		
Adjustment	123	102
Care	124	104
Equipment	122	101
Installation	126	104
Message transmission	128	106
Procedure	129	107
Training	125	104
Lettering	42	39
Line route map	175	137
Message center:		
Abbreviations	24	20
Definitions	13	9
Equipment and forms, divisions and higher units	26	20

INDEX

	Paragrap.	
Message center—Continued.		
Flexibility of organization.....	17	
Forms and equipment, headquarters below the division.....	33	30
Informal contact with neighboring.....	19	15
Organization, divisions and higher units.....	25	20
Organization, headquarters below the division.....	32	29
Principles of operation.....	20	16
Purpose.....	14	9
Records, headquarters below the division.....	34	30
Related procedures for the electrical transmission of messages.....	37	37
Responsibility.....	16	13
Training.....	18	14
Messages:		
Classification.....	15	10
Dropped.....	77	69
Dropping grounds.....	78	69
Equipment for dropping.....	80	69
Equipment for picking up.....	83	70
Handling of secret.....	29	28
Multiple distribution.....	21	18
Pick-up.....	81	70
Pick-up field.....	82	70
Preparation and arrangement of equipment for picking up.....	83	70
Procedure:		
Dropping.....	79	69
Handling in lower units.....	35	32
Handling incoming, divisions and higher units.....	28	26
Handling outgoing, divisions and higher units.....	27	23
Handling relay, divisions and higher units.....	30	29
Picking up.....	84	72
Skeleton copy.....	27	23
Training for pick-up.....	85	73
Messenger:		
Airplane.....	65	63
Basic training.....	61	61
Bicycle.....	64	62
Carrying messages.....	70	65
Delivery of messages.....	71	66
Double.....	72	67
Motor.....	64	62
Motorcycle.....	64	62
Mounted.....	63	62
Personnel.....	59	60
Receipt of messages for delivery.....	69	64
Relay posts.....	75	68
Routes.....	73	67
Runner.....	62	62
Selection of type used.....	68	63
Scheduled.....	74	68

INDEX

	Paragraph	Page
Messenger—Continued.		
Scheduled service.....	27	23
Service.....	36	36
System.....	22	18
Messenger communication:		
Equipment for.....	60	61
Necessity for.....	58	60
Numerals, pronunciation.....	182	144
Object of text.....	2	1
Orders, records, and reports.....	257, 258	249
Field orders.....	260	252
Forms.....	262	257
Signal Unit Journal.....	-----	261
Check lists:		
Order of Signal Unit.....	-----	261
Signal Annex to Field Orders.....	-----	259
Signal Estimate of the Situation.....	-----	258
Examples:		
Circuit Diagram.....	-----	260
Line Route Map.....	-----	262
Signal Operation Instructions:		
Cipher Keys for Cipher Device M-94.....	-----	272
Geographical Supplement to DFC-T1.....	-----	273
Identification Panel Code.....	-----	269
Index to Regulations and Orders.....	-----	265
Map Coordinate Code.....	-----	277
Pyrotechnic Code.....	-----	279
Radio Call Signs.....	-----	284
Radio Frequencies.....	-----	282
Supplement to AGL-T1.....	-----	266
Supplement to FCC-T1.....	-----	268
Telephone Directory.....	-----	280
Traffic Diagram.....	-----	262
Signal operation instructions.....	261	255
Steps involved in each tactical operation.....	259	250
Panels.....	153	121
Between airplane radio and ground station with radio receiver only.....	151	120
Care.....	143	114
Display grounds.....	145	115
Displaying the identification group.....	148	116
Equipment.....	142	114
Identification group.....	147	116
Indicating completion of work.....	154	121
Numerals.....	146	116
Purpose.....	144	115
Reporting of airplane.....	150	120
Special signals.....	155	122
Technique of display.....	149	119
Phonetic alphabet.....	181	143
Pigeon communication, employment.....	86	74

INDEX

	Paragraph	
Pigeons	254	
Delivery, care, and use	87	70
Releasing	89	77
Transporting	88	77
Pole climbing	192	169
Equipment	191	167
Publications relating to signal communication	4	1
Pyrotechnics:		
Care	137	112
Equipment	136	110
Signals	140	113
Training	139	113
Transmission	141	113
Use	138	112
Radio call signs	41	39
Radio communication:		
Assignment of frequencies and call signs	94	84
Codes and ciphers	100	87
Cooperation with the message center	104	89
Definitions	90	81
Employment	91	83
Operator's number sheet	108	91
Personal sign	106	90
Powers and limitations	92	83
Procedure and procedure signals	99	87
Procedures, special	119	98
Radio nets and net control stations:		
Control	113	95
Establishment	117	96
General	112	94
Operation	114	95
Reception	105	90
Regulations, general operating	98	86
Servicing of messages	107	90
Special uses	97	86
Station log	109	92
Station records:		
Disposition	110	94
Importance	111	94
Time entries and the radio day	103	89
Traffic	116	96
Internet	118	97
Transmission in code and in clear	115	96
Transmissions	102	88
Transmitting rules	101	88
Radio nets and net control stations	93	84
Personal sign, operator's	106	90
Radio stations, location	96	85
Repair of equipment	255	248
Scope of text	3	1
Signal agencies and means, division	8	4

INDEX

	Paragraph	Page
Signal communication:		
Definitions	5	3
General	1	1
Responsibility	10	5
Teamwork	9	5
Signal officer:		
Duties	12	7
Staff and command functions	11	6
Signal supply:		
Classification	247	245
Division personnel	248	245
General	246	245
Receipt, transportation, and issue	250, 251	247
Requisitions	249	245
Signal systems	7	4
Sound communication:		
Definition	157	125
Employment	160	125
Messages	159	125
Objects used	158	125
Station lists	39	39
Station log	109, 224	92, 222
Switchboards:		
BD-9 and BD-11	215	209
Conference calls	216	217
Installation	210	202
Operating phrases	220	219
Operator	219	219
Supervision	221	221
Types of field	215	209
Switching centrals	170	134
Symbols, special	178	138
Systems, signal	7	4
Telegraph:		
Call signs	41	39
Operating procedure	233	228
Powers and limitations	168	134
Way stations	230	226
Telegraph communication, establishing	232	227
Telegraph sets and stations:		
Employment and circuits	226, 227	224
Types of field	231	227
Telephone:		
Care of equipment	218	218
Conversations	178	141
Directory	40, 177	39, 141
EE-4	208	195
EE-5	208	195
Installation	207	195
Powers and limitations	167	133
Traffic diagram	222	221
Types	203	195
Telephone centrals	169	134
Records	223	222
Reports to message center	225	224

INDEX

	Paragraph	Page
Terminal strips.....	190	166
Test stations.....	171	134
Time, Army and Navy methods of specifying.....	38	38
Units, signal and communication.....	6	3
Urgent calls.....	179, 217	142, 218
Visual call signs.....	41	39
Visual communication:		
Airplanes.....	156	124
Possibilities and employment.....	121	99
Scope.....	120	99
Wire:		
Protection.....	194	178
Recovery.....	195	178
Splices:		
General.....	186	146
Making various.....	188	146
Taping.....	187	157
Tags, circuit-marking.....	189	165
Ties.....	188	158
Wire circuits:		
Classification.....	164	128
Designating.....	174	136
Wire communication:		
Construction orders.....	197	179
Definitions.....	161	126
During movement of command posts.....	166	129
Orders and instructions.....	172	136
Purpose and scope.....	162	127
Responsibility.....	165	129
Wire equipment, transportation.....	245	243
Wire-laying equipment.....	193	175
Wire system:		
Composition.....	163	127
Reports and records.....	183	145

